

# Wood-Mizer<sup>®</sup> Sawmill

## Parts Manual

---

LT40HD Remote

rev. K5.04 - K7.05

---

**Safety is our #1 concern!**

*January 2010*

*Form #1650*

### MODELS

LT40HDD35-RA

LT40HDD35-RS

LT40HDD35N-RA

LT40HDD35N-RS

LT40HDD35W-RA

LT40HDD35W-RS

LT40HDD35NW-RS

LT40HDD35NW-RA

LT40HDG26-RA

LT40HDG26-RS

LT40HDG26W-RS

LT40HDG26W-RA

LT40HDG38-RA

LT40HDG38-RS

LT40HDG38W-RA

LT40HDG38W-RS



**WARNING! Read and understand this manual before using this machine.**

**California**

## Proposition 65 Warning



**WARNING:** Breathing gas/diesel engine exhaust exposes you to chemicals known to the State of California to cause cancer and birth defects or other reproductive harm.

Always start and operate the engine in a well-ventilated area.  
If in an enclosed area, vent the exhaust to the outside.  
Do not modify or tamper with the exhaust system.  
Do not idle the engine except as necessary.

For more information go to **[www.P65warnings.ca.gov](http://www.P65warnings.ca.gov)**.



**WARNING:** Drilling, sawing, sanding or machining wood products can expose you to wood dust, a substance known to the State of California to cause cancer. Avoid inhaling wood dust or use a dust mask or other safeguards for personal protection.

For more information go to **[www.P65Warnings.ca.gov/wood](http://www.P65Warnings.ca.gov/wood)**.

**Active Patents assigned to Wood-Mizer, LLC**

Wood-Mizer, LLC has received patents that protect our inventions which are a result of a dedication to research, innovation, development, and design. Learn more at: [woodmizer.com/patents](http://woodmizer.com/patents)

**©August 16, 2024 Wood-Mizer LLC**

Printed in the United States of America, all rights reserved. No part of this manual may be reproduced in any form by any photographic, electronic, mechanical or other means or used in any information storage and retrieval system without written permission from

**Wood-Mizer, LLC**  
**8180 West 10th Street**  
**Indianapolis, Indiana 46214**

**SECTION 1 REPLACEMENT PARTS**

1.1 How To Use The Parts List..... 1-1  
     *To Order Parts* ..... *1-1*  
 1.2 Sample Assembly..... 1-1  
 1.3 Torque Values..... 1-2

**SECTION 2 BLADE GUIDE ROLLERS & ARM**

2.1 Blade Guide Assembly, Idle Side ..... 2-1  
 2.2 Blade Guide Assembly, Drive Side ..... 2-4  
 2.3 Blade Guide Arm Drive Assembly ..... 2-7  
 2.4 Blade Guide Arm ..... 2-9

**SECTION 3 BLADE WHEELS & TENSIONER**

3.1 Blade Drive Assembly - D35 and G38 Engines ..... 3-1  
 3.2 Blade Drive Assembly - G26 Engine..... 3-3  
 3.3 Idle Blade Wheel Assembly..... 3-5  
 3.4 Hydraulic Blade Tensioner Assembly ..... 3-6

**SECTION 4 SAW HEAD FRAME**

4.1 Middle Throat Screw ..... 4-1  
 4.2 Water Lube Solenoid Valve..... 4-2  
 4.3 Clutch Pivot..... 4-3  
 4.4 Clutch Mount Assembly ..... 4-4  
 4.5 Brake Assembly ..... 4-5  
 4.6 Water Lube Assembly (2024-Present)..... 4-6  
 4.7 Water Lube Assembly (2019-2024, Used on all trays) ..... 4-7  
 4.8 Water Lube/Fuel Tray Assembly (2015, Gas Only)..... 4-8  
 4.9 Water Lube Assembly (All prior to 2015 - Electric Only after 2015). 4-10  
 4.10 Fuel Tray (Gasoline) ..... 4-12  
 4.11 Fuel Tray (Diesel - US Only)..... 4-14  
 4.12 Fuel Tray (Diesel - International) ..... 4-16  
 4.13 Saw Head Decals ..... 4-17  
 4.14 Blade Housing Covers ..... 4-18  
 4.15 Drive Belt Covers ..... 4-19  
 4.16 Sawdust Chute ..... 4-20  
 4.17 Board Return Assembly (Optional) ..... 4-21  
 4.18 Wire Box/Hole Plugs ..... 4-22

**SECTION 5 CONTROL & BATTERY BOXES**

5.1 Control Assembly (Accuset)..... 5-1  
 5.2 Control Box (SimpleSet)..... 5-3  
 5.3 Control Assembly (D35 - US Only) (Accuset)..... 5-5  
 5.4 Control Box (SimpleSet) (D35 - US Only)..... 5-7  
 5.5 Drum Switches..... 5-9  
 5.6 Front Panel Assembly ..... 5-10  
 5.7 Front Panel Assembly & Harnesses (D35 - US Only)..... 5-11  
 5.8 Battery Box Assembly ..... 5-12  
 5.9 Fuse Box Assembly ..... 5-13  
 5.10 Remote Power Box Assembly (Accuset)..... 5-15

# Table of Contents

# Section-Page

5.11	Remote Power Box (SimpleSet).....	5-17
5.12	Remote Power Box Door Assembly.....	5-19

## SECTION 6 UP/DOWN SYSTEM

6.1	Head Mount .....	6-1
6.2	Blade Height & Quarter Scales .....	6-2
6.3	Up/Down Chain & Sprockets.....	6-4
6.4	Up/Down Assembly .....	6-5

## SECTION 7 POWER FEED SYSTEM

7.1	Upper Track Rollers And Wipers.....	7-1
7.2	Power Feed Assembly .....	7-2
7.3	Feed Chain/Stop and Taillight.....	7-4
7.4	Lower Track Rollers.....	7-5

## SECTION 8 BED FRAME ASSEMBLY

8.1	Bed Rail Assembly, Front And Rear .....	8-1
8.2	Bed Rail Assembly, Middle Front.....	8-2
8.3	Bed Rail Assembly, Middle Rear .....	8-3
8.4	Pivot Bed Rail Assembly .....	8-4
8.5	Log Side Support Assembly (Manual) .....	8-5
8.6	Transport Safety Chain and Rest Pin.....	8-6
8.7	Bed Frame Decals .....	8-7
8.8	Cable Chain Assembly .....	8-8
8.9	Energy Chain (Cat Track) Mounts .....	8-9
8.10	Energy Chain (Cat Track) Tray .....	8-10
8.11	Energy Chain Transport Bracket.....	8-11
8.12	Board Return Table Assembly .....	8-12
8.13	Board Outfeed Table (Optional).....	8-13

## SECTION 9 BED HYDRAULIC SYSTEM

9.1	Hydraulic Hoses .....	9-1
9.2	Command Control .....	9-2
9.3	Hydraulic Pump Box .....	9-4
9.4	Hydraulic Log Loader .....	9-6
9.5	Hydraulic Log Turner .....	9-8
9.6	Hydraulic Log Side Supports .....	9-9
9.7	Hydraulic Log Clamp - base .....	9-11
9.8	Hydraulic Log Clamp - clamp .....	9-12
9.9	Hydraulic Toe Board .....	9-13
9.10	Hydraulic Power Supply Strip .....	9-14

## SECTION 10 MISCELLANEOUS

10.1	Replacement Manuals .....	10-1
------	---------------------------	------

## SECTION 1 REPLACEMENT PARTS

### 1.1 How To Use The Parts List

- Use the table of contents to locate the assembly that contains the part you need.
- Go to the appropriate section and locate the part in the illustration.
- Use the number pointing to the part to locate the correct part number and description in the table.
- Parts shown indented under another part are included with that part.

#### To Order Parts

- From the continental US, call **1-800-525-8100** to order parts. Have your customer number, vehicle identification number, and part numbers ready when you call.
- From other international locations, contact the Wood-Mizer distributor in your area for parts.

### 1.2 Sample Assembly



REF	PART #	DESCRIPTION	COMMENTS	QTY.
	012345	SAMPLE ASSEMBLY, COMPLETE	INCLUDES ITEMS 1-6	1
1	F02222-22	Sample Part		1
2	F03333-33	Sample Part		2
	098765	Sample Subassembly	Includes items 3-6	1
3	S04444-44	Subassembly Sample Part		1
4	K55555	Subassembly Sample Part		1
	054321	Sample Sub-Subassembly	Includes items 5-6	2
5	022222	Sub-Subassembly Sample Part		1
6	F10234-56	Sub-Subassembly Sample Part		1

The Sample Assembly, Complete, part number 02345 (top level assembly) includes two parts (F0222-22 and F0333-33) and the 098765 subassembly.

Subassembly 098765 contains two parts(S04444-44 and K55555) and two copies of sub-subassembly 054321.

Each sub-subassembly 054321 contains two parts (022222 and F10234-56).

### 1.3 Torque Values

Grade		Units	SAE 5	SAE 8
Grade Mark				
Bolt Dia.	Threads Per In.	Units	SAE 5	SAE 8
6	32	in-lbs (Nm)	20 (2.3)	-
8	32	in-lbs (Nm)	24 (2.7)	30 (3.4)
10	24	in-lbs (Nm)	35 (4.0)	45 (5.1)
10	32	in-lbs (Nm)	40 (4.5)	50 (5.7)
12	24	in-lbs (Nm)	50 (5.7)	65 (7.3)
1/4	20	in-lbs (Nm)	95 (10.7)	125 (14.1)
1/4	28	in-lbs (Nm)	95 (10.7)	150 (17.0)
5/16	18	ft-lbs (Nm)	17 (22.6)	23 (31.2)
5/16	24	ft-lbs (Nm)	20 (27.1)	25 (33.8)
3/8	16	ft-lbs (Nm)	30 (40.7)	40 (54.2)
3/8	24	ft-lbs (Nm)	35 (47.5)	45 (61.0)
7/16	14	ft-lbs (Nm)	50 (67.8)	65 (88.1)
7/16	20	ft-lbs (Nm)	55 (74.6)	70 (94.9)
1/2	13	ft-lbs (Nm)	75 (101.7)	100 (135.6)
1/2	20	ft-lbs (Nm)	85 (115.3)	110 (149.2)
9/16	12	ft-lbs (Nm)	105 (142.4)	135 (183.1)
9/16	18	ft-lbs (Nm)	115 (155.9)	150 (203.4)
5/8	11	ft-lbs (Nm)	150 (203.4)	195 (264.4)
5/8	18	ft-lbs (Nm)	160 (217.0)	210 (284.8)
3/4	10	ft-lbs (Nm)	170 (230.5)	220 (298.3)
3/4	16	ft-lbs (Nm)	175 (237.3)	225 (305.1)
7/8	9	ft-lbs (Nm)	302 (409.5)	473 (640.9)
7/8	14	ft-lbs (Nm)	300 (406.8)	400 (542.4)
1	8	ft-lbs (Nm)	466 (631.8)	714 (967.4)

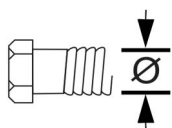

Metric Bolt Head Identification

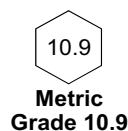
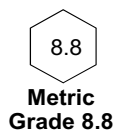

COARSE THREAD					FINE THREAD				Wrench Size	
Diameter & Thread Pitch	Metric 8.8		Metric 10.9		Diameter & Thread Pitch	Metric 8.8		Metric 10.9		
	N-m	lbs-ft	N-m	lbs-ft		N-m	lbs-ft	N-m		lbs-ft
6 x 1.0	8	6	11	8					10 mm	
8 x 1.25	20	15	27	20	8 x 1.0	21	16	29	22	13 mm
10 x 1.5	39	29	54	40	10 x 1.25	41	30	57	42	16 mm
12 x 1.75	68	50	94	70	12 x 1.25	75	55	103	76	18 mm
14 x 2.0	109	80	151	111	14 x 1.5	118	87	163	120	21 mm
16 x 2.0	169	125	234	173	16 x 1.5	181	133	250	184	24 mm
18 x 2.5	234	172	323	239	18 x 1.5	263	194	363	268	27 mm
20 x 2.5	330	244	457	337	20 x 1.5	367	270	507	374	30 mm
22 x 2.5	451	332	623	460	22 x 1.5	495	365	684	505	34 mm
24 x 3.0	571	421	790	583	24 x 2.0	623	459	861	635	36 mm
30 x 3.0	1175	867	1626	1199	30 x 2.0	1258	928	1740	1283	46 mm

## SECTION 2 BLADE GUIDE ROLLERS & ARM

### 2.1 Blade Guide Assembly, Idle Side

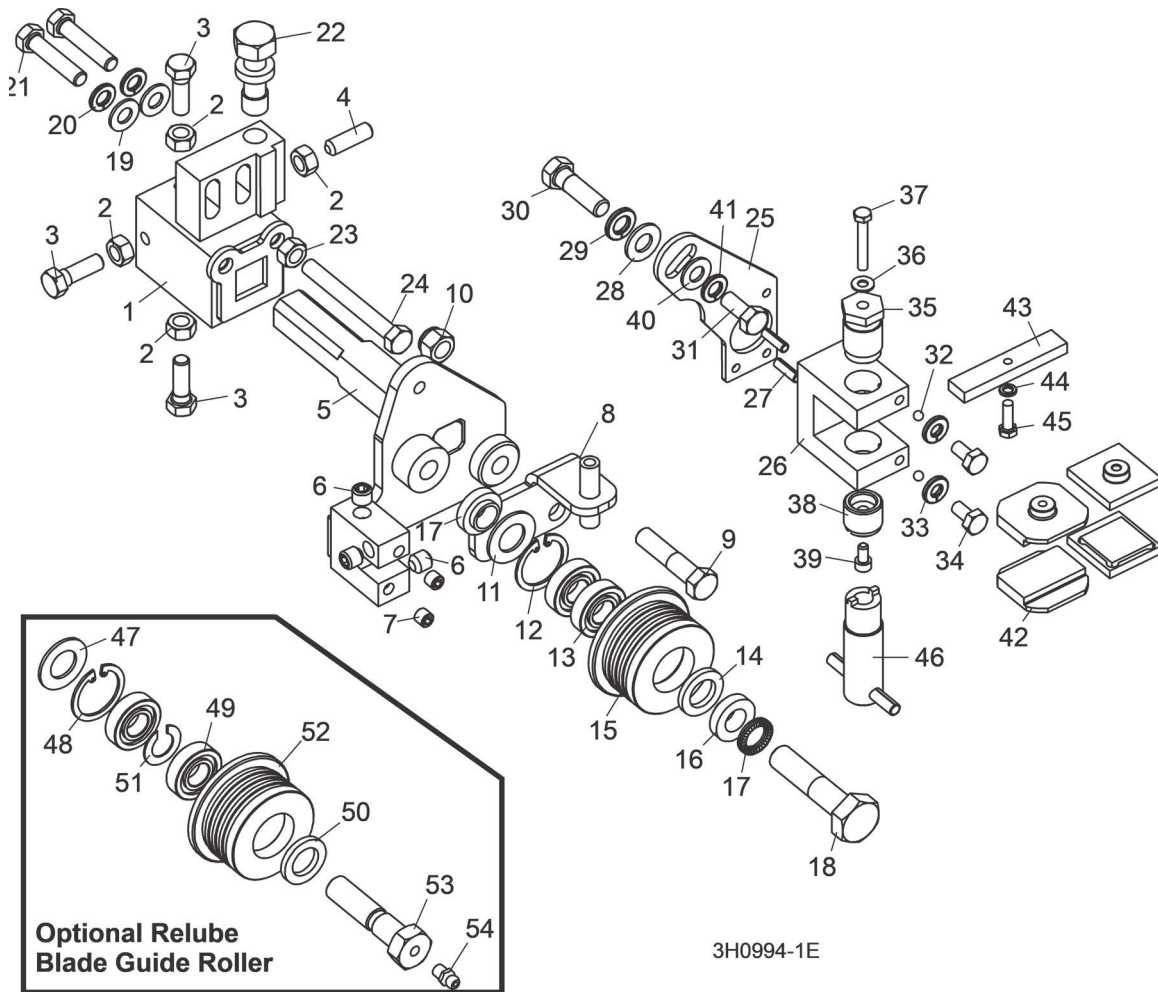

REF	PART #	DESCRIPTION	COMMENTS	QTY.
	003992	<b>GUIDE ASSEMBLY, IDLE SIDE BLADE ROLLER</b>		1
	003920	Block Assembly, Idle Side Blade Guide Mount		1
<b>1</b>	003921	Block Weldment, Blade Guide Mount	Available in assemblies only.	1
<b>2</b>	F05010-17	Nut, 5/16-18 Hex		4
<b>3</b>	F05006-88	Bolt, 5/16-18 x 1" Hex Head Stainless Steel		3
<b>4</b>	F05006-122	Screw, 5/16-18 x 1" Socket Head Flat Point Stainless Steel Set		1
<b>5</b>	003924	Shaft Weldment, Idle Side Guide		1
<b>6</b>	P30127	Fitting, 1/8" NPT Socket Pipe Plug		3
<b>7</b>	007734	Fitting, 1/16" NPT Socket Pipe Plug		2
<b>8</b>	006322	Bracket Weldment, Idle Side Water Lube		1
<b>9</b>	F05007-78	Bolt, 3/8-16x1 1/2 Hex Head Grade 5		1
<b>10</b>	F05010-10	Nut, 3/8-16 Hex Nylon Lock		1
	A04925	Roller Assembly, Blade Guide (standard)		1

## 2 Blade Guide Rollers & Arm

Blade Guide Assembly, Idle Side

REF	PART #	DESCRIPTION	COMMENTS	QTY.
	014299	Roller Assembly, Extended Blade Guide (optional for use with 1 1/2" blades)	High-Performance Blade Guide Kit requires LMS blade lube system. Use kit 006325 to upgrade both drive and idle side blade guides to High-Performance. If sawmill not already equipped with LMS, add kit .	1
	K07079	Bearing Kit, Blade Guide Rebuild		1
11	P04252	Washer, 5/8" White Felt		1
12	F04254-1	Ring, 1 1/8" Interior Retaining		1
13	015975	Bearing, R8-2RS Blade Guide	Available in assemblies only.	2
14	P06455	Washer, 5/8" Gray Felt		1
	F05005-105	Screw, 1/4-28 x 1/4" Socket Head Cup Point Set Black Oxide		1
	057407-1507	Instruction Sheet, Blade Guide Rebuild		1
15	S04250	Roller, Flanged Blade Guide	Available in assemblies only.	1
	014298	Roller, Flanged Blade Guide (1 1/2" blade)	Available in assemblies only.	1
	A04925-364	Instruction Sheet, Blade Guide Roller Replacement		1
16	S04253	Spacer, Blade Guide		2
17	F05011-125	Washer, 1/2" Nord-Lock		1
18	F05008-10	Bolt, 1/2-13 x 2 1/4" Hex Head Grade 5		1
19	F05011-17	Washer, 5/16" SAE Flat		2
20	F05011-13	Washer, 5/16" Split Lock		2
21	F05006-76	Bolt, 5/16-18 x 1 1/2" Hex Head		2
22	035656	Bolt, Blade Guide Vertical Adjustment		1
23	F05010-17	Nut, 5/16-18 Hex		1
24	F05006-136	Bolt, 5/16-18 x 2 3/4" Hex Head Full Thread		1
	006325	<b>GUIDE KIT, HIGH-PERFORMANCE BLADE GUIDE (OPTIONAL)</b>	High-Performance Blade Guide Kit requires LMS blade lube system. Use kit 006325 to upgrade both drive and idle side blade guides to High-Performance. If sawmill not already equipped with LMS, add kit .	1
	003928	Block Assembly, Idle Side Blade Guide		1
25	003915	Plate, Block Tilt Adjustment		1
26	003909	Block, Guide Block Mount		1
27	F05012-22	Pin, 3/16" x 5/8" Roll		2
28	F05011-3	Washer, 3/8" SAE Flat		1
29	F05011-4	Washer, 3/8" Split Lock		1
30	F05007-123	Bolt, 3/8-16 x 1 1/4" Hex Head Grade 5		1
31	F05006-102	Bolt, 5/16-18 x 3/4" Hex Head		1
32	003914	Ball, 3/16" Dia. Nylon		2
33	F05011-14	Washer, 1/4" Split Lock		2
34	F05005-15	Bolt, 1/4-20 x 1/2" Hex Head		2
35	003994	Bolt, Blade Guide Block Mount		1
36	042867	Washer, #10 Brass		1
37	F05004-240	Bolt, #10-32 x 1 1/4" Hex Head Stainless Steel		1
38	044057	Screw, Lower Block Adjustment		1



REF	PART #	DESCRIPTION	COMMENTS	QTY.
39	F05004-200	Screw, #10-32 x 3/8" Socket Head Stainless Steel		1
40	F05011-17	Washer, 5/16" SAE Flat		1
41	F05011-13	Washer, 5/16" Split Lock		1
42	052355	Block, Blade Guide Wear (Standard for 1 1/4" Blades)	052355 blocks for use with 1 1/4" blade provided as standard equipment. EZ-Glide blocks 036347 are available for customers who prefer this block.	2
	052309	Block, Blade Guide Wear (Optional for 1 1/2" Blades)	Bearing must be modified for use with relube roller assemblies. Remove one seal from each bearing, place open sides facing each other and place spacer 035411 between bearings.	2
	036347	Block Assembly, 1" Sq. EZ-Glide Wear		2
43	035799	Block, Blade Guide Alignment		1
44	F05011-20	Washer, #10 Split Lock		1
45	F05004-152	Screw, #10-32 x 5/8" Hex Head		1
46	044064	Adjustment Tool, Lower Guide Block		1
	035248	Shim, .008" Blade Guide Block Spacer		1
		Drive Side Blade Guide Parts ( )	<a href="#">(See Section 2.1)</a>	
	016568	<b>ROLLER ASSEMBLY, BLADE GUIDE RELUBE (OPTIONAL)</b>		1
	057405	<b>ROLLER ASSEMBLY, EXTENDED BLADE GUIDE RELUBE (OPTIONAL FOR USE WITH 1 1/2" BLADES)</b>	High-Performance Blade Guide Kit requires LMS blade lube system. Use kit 006325 to upgrade both drive and idle side blade guides to High-Performance. If sawmill not already equipped with LMS, add kit .	1
	057407	Bearing Kit, Relube Blade Guide Rebuild		1
47	P04252	Washer, 5/8" White Felt		1
48	F04254-1	Ring, 1 1/8" Interior Retaining		1
49	015975	Bearing, R8-2RS Blade Guide	Available in assemblies only. Bearing must be modified for use with relube roller assemblies. Remove one seal from each bearing, place open sides facing each other and place spacer 035411 between bearings.	2
50	P06455	Washer, 5/8" Gray Felt		1
51	035411	Spacer, Blade Guide Bearing		1
	057407-1507	Instruction Sheet, Blade Guide Rebuild		1
52	035426	Roller, Flanged Blade Guide (Relube)	Available in assemblies only.	1
	057402	Roller, Flanged Blade Guide (Relube 1 1/2" blade)	Available in assemblies only.	1
	A04925-364	Instruction Sheet, Blade Guide Roller Replacement		1
53	036161	<b>BOLT, BLADE GUIDE ROLLER (RELUBE ONLY)</b>		1
54	P05060	<b>FITTING, 1/4-28 GREASE (RELUBE ONLY)</b>		1

## 2.2 Blade Guide Assembly, Drive Side

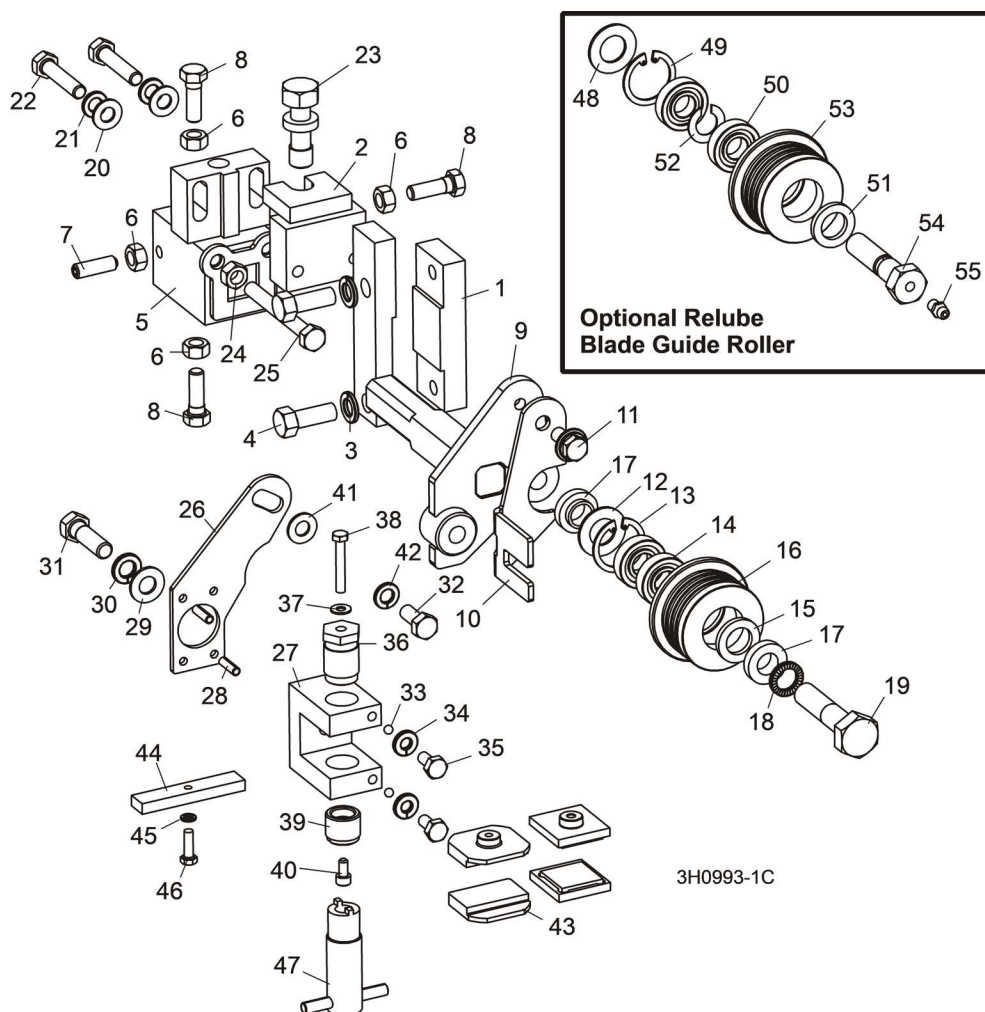

REF	PART #	DESCRIPTION	COMMENTS	QTY.
1	016548	BLOCK, BOLT ON BLADE GUIDE MOUNT		1
2	003964	BRACKET WELDMENT, INNER BLADE GUIDE MOUNT		1
3	F05011-4	WASHER, 3/8" SPLIT LOCK		2
4	F05007-7	BOLT, 3/8-16 X 1" HEX HEAD		2
	003905	GUIDE ASSEMBLY, DRIVE SIDE BLADE ROLLER		1
	003910	Block Assembly, Blade Guide Mount		1
5	003911	Block Weldment, Blade Guide Mount	Available in assemblies only.	1
6	F05010-17	Nut, 5/16-18 Hex		4
7	F05006-122	Screw, 5/16-18 x 1" Socket Head Flat Point Stainless Steel Set		1
8	F05006-88	Bolt, 5/16-18 x 1" Hex Head Stainless Steel		3
9	003913	Shaft Weldment, Drive Side Guide		1
10	003916	Plate, Blade Guide Deflector		1
11	F05006-101	Bolt, 5/16-18 x 3/4" Hex Head w/Flat & Lock Washer		1
	A04925	Roller Assembly, Blade Guide (standard)		1

REF	PART #	DESCRIPTION	COMMENTS	QTY.
	014299	Roller Assembly, Extended Blade Guide (optional for use with 1 1/2" blades)	High-Performance Blade Guide Kit requires LMS blade lube system. Use kit 006325 to upgrade both drive and idle side blade guides to High-Performance. If sawmill not already equipped with LMS, add kit .	1
	K07079	Bearing Kit, Blade Guide Rebuild		1
12	P04252	Washer, 5/8" White Felt		1
13	F04254-1	Ring, 1 1/8" Interior Retaining		1
14	015975	Bearing, R8-2RS Blade Guide	Available in assemblies only.	2
15	P06455	Washer, 5/8" Gray Felt		1
	F05005-105	Screw, 1/4-28 x 1/4" Socket Head Cup Point Set Black Oxide		1
	057407-1507	Instruction Sheet, Blade Guide Rebuild		1
16	S04250	Roller, Flanged Blade Guide	Available in assemblies only.	1
	014298	Roller, Flanged Blade Guide (1 1/2" blade)	Available in assemblies only.	1
	A04925-364	Instruction Sheet, Blade Guide Roller Replacement		1
17	S04253	Spacer, Blade Guide		2
18	F05011-125	Washer, 1/2" Nord-Lock		1
19	F05008-10	Bolt, 1/2-13 x 2 1/4" Hex Head Grade 5		1
20	F05011-17	Washer, 5/16" SAE Flat		2
21	F05011-13	Washer, 5/16" Split Lock		2
22	F05006-93	Bolt, 5/16-18 x 1 1/4" Hex Head		2
23	035656	Bolt, Blade Guide Vertical Adjustment		1
24	F05010-17	Nut, 5/16-18 Hex		1
25	F05006-136	Bolt, 5/16-18 x 2 3/4" Hex Head Full Thread		1
	006325	<b>GUIDE KIT, HIGH-PERFORMANCE BLADE GUIDE (OPTIONAL)</b>	High-Performance Blade Guide Kit requires LMS blade lube system. Use kit 006325 to upgrade both drive and idle side blade guides to High-Performance. If sawmill not already equipped with LMS, add kit.	1
	003927	Block Assembly, Drive Side Blade Guide		1
26	003915	Plate, Block Tilt Adjustment		1
27	003909	Block, Guide Block Mount		1
28	F05012-22	Pin, 3/16" x 5/8" Roll		2
29	F05011-3	Washer, 3/8" SAE Flat		1
30	F05011-4	Washer, 3/8" Split Lock		1
31	F05007-123	Bolt, 3/8-16 x 1 1/4" Hex Head Grade 5		1
32	F05006-102	Bolt, 5/16-18 x 3/4" Hex Head		1
33	003914	Ball, 3/16" Dia. Nylon		2
34	F05011-14	Washer, 1/4" Split Lock		2
35	F05005-15	Bolt, 1/4-20 x 1/2" Hex Head		2
36	003994	Bolt, Blade Guide Block Mount		1
37	042867	Washer, #10 Brass		1
38	F05004-240	Bolt, #10-32 x 1 1/4" Hex Head -SS		1
39	044057	Screw, Lower Block Adjustment		1
40	F05004-200	Screw, #10-32 x 3/8" Socket Head -SS		1

## 2 Blade Guide Rollers & Arm

Blade Guide Assembly, Drive Side

REF	PART #	DESCRIPTION	COMMENTS	QTY.
41	F05011-17	Washer, 5/16" SAE Flat		1
42	F05011-13	Washer, 5/16" Split Lock		1
43	052355	Block, Blade Guide Wear (Standard for 1 1/4" Blades)	052355 blocks for use with 1 1/4" blade provided as standard equipment. EZ-Glide blocks 036347 are available for customers who prefer this block.	2
	052309	Block, Blade Guide Wear (Optional for 1 1/2" Blades)	Bearing must be modified for use with relube roller assemblies. Remove one seal from each bearing, place open sides facing each other and place spacer 035411 between bearings.	2
	036347	Block Assembly, 1" Sq. EZ-Glide Wear	052355 blocks for use with 1 1/4" blade provided as standard equipment. EZ-Glide blocks 036347 are available for customers who prefer this block.	2
44	035799	Block, Blade Guide Alignment		1
45	F05011-20	Washer, #10 Split Lock		1
46	F05004-152	Screw, #10-32 x 5/8" Hex Head		1
47	044064	Adjustment Tool, Lower Guide Block		1
	035248	Shim, .008" Blade Guide Block Spacer		1
		Idle Side Blade Guide Parts ( <a href="#">See Section 2.1</a> )		
	016568	<b>ROLLER ASSEMBLY, BLADE GUIDE RELUBE (OPTIONAL)</b>		1
	057405	<b>ROLLER ASSEMBLY, EXTENDED BLADE GUIDE RELUBE (OPTIONAL FOR USE WITH 1 1/2" BLADES)</b>	High-Performance Blade Guide Kit requires LMS blade lube system. Use kit 006325 to upgrade both drive and idle side blade guides to High-Performance. If sawmill not already equipped with LMS, add kit .	1
	057407	Bearing Kit, Relube Blade Guide Rebuild		1
48	P04252	Washer, 5/8" White Felt		1
49	F04254-1	Ring, 1 1/8" Interior Retaining		1
50	015975	Bearing, R8-2RS Blade Guide	Available in assemblies only. Bearing must be modified for use with relube roller assemblies. Remove one seal from each bearing, place open sides facing each other and place spacer 035411 between bearings.	2
51	P06455	Washer, 5/8" Gray Felt		1
52	035411	Spacer, Blade Guide Bearing		1
	057407-1507	Instruction Sheet, Blade Guide Rebuild		1
53	035426	Roller, Flanged Blade Guide (Relube)	Available in assemblies only.	1
	057402	Roller, Flanged Blade Guide (Relube 1 1/2" blade)	Available in assemblies only.	1
	A04925-364	Instruction Sheet, Blade Guide Roller Replacement		1
54	036161	<b>BOLT, BLADE GUIDE ROLLER (RELUBE ONLY)</b>		1
55	P05060	<b>FITTING, 1/4-28 GREASE (RELUBE ONLY)</b>		1

## 2.3 Blade Guide Arm Drive Assembly

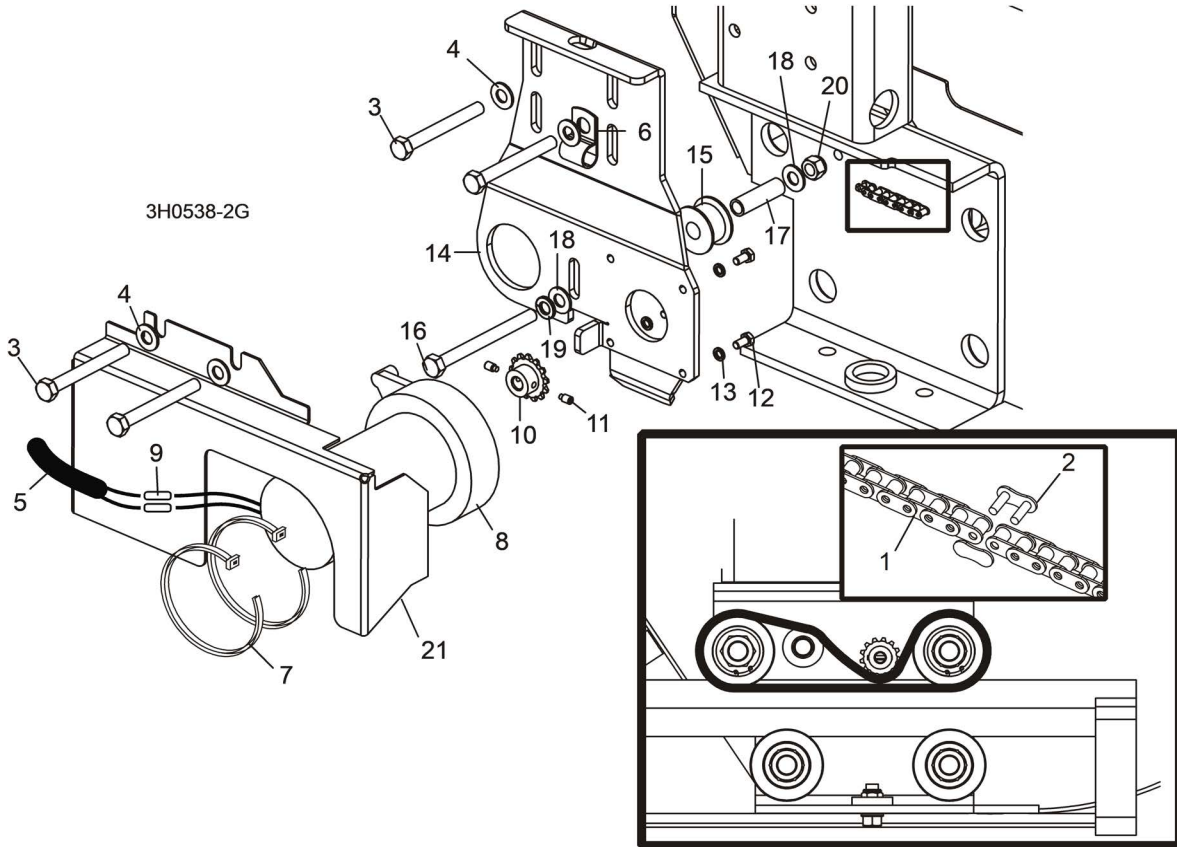

REF	PART #	DESCRIPTION	COMMENTS	QTY.
1	P09984	CHAIN, #25 X 20 1/4"		1
2	P09983	LINK, #25 MASTER		1
3	F05006-28	BOLT, 5/16-18 X 2 3/4" HEX HEAD GRADE 5		4
4	F05011-17	WASHER, 5/16" SAE FLAT		4
5	R01897	TUBE, 3/8" X 1/2" NEOPRENE		2.5ft
6	P07584	CLAMP, 1/2" COATED EMT		2
7	F05089-1	WRAP, 1/4" X 6" TIE		2
	015989	DRIVE ASSEMBLY, BLADE GUIDE ARM		1
	079215	Motor Assembly, Blade Guide Arm Replacement		1
8	079214	Motor, Current Applications 1/30HP 12VDC Gear		1
	061232	Gear Kit, Motor Replacement (Current Application)		1
	061234	Brush Kit, Gear Motor Replacement (Current Application)		1
	061233	Shaft Kit, Gear Motor Replacement (Current Application)		1
9	F04875-1	Connector, 14 Gauge Butt		2
10	P09970	Sprocket, Gear Motor #25 14-Tooth		1
11	F05004-274	Screw, #10-24 x 1/4" Full Dog Point Socket Set		2
12	F05004-60	Screw, #10-32 x 1/2" Hex Head		4
13	F05011-20	Washer, #10 Split Lock		4
	A10365-296	Instruction Sheet, Blade Guide Arm Motor		1

## 2 Blade Guide Rollers & Arm

### Blade Guide Arm Drive Assembly

REF	PART #	DESCRIPTION	COMMENTS	QTY.
14	015939	Bracket, Blade Guide Arm Motor Mount		1
15	S09999	Roller, Blade Guide Arm Chain Idler		1
16	F05006-3	Bolt, 5/16-18 X 3 1/2" Hex Head Full Thread		1
17	S09996	Spacer, 5/16" I.D. X 1 1/2"		1
18	F05011-17	Washer, 5/16" SAE Flat		2
19	F05011-13	Washer, 5/16" Split Lock		1
20	F05010-58	Nut, 5/16-18 Hex Nylon Lock		1
21	S11617	<b>COVER, BLADE GUIDE ARM MOTOR</b>		1
	S12029	<b>GUARD, BLADE GUIDE ARM (G.S. ONLY)</b>		1

## 2.4 Blade Guide Arm

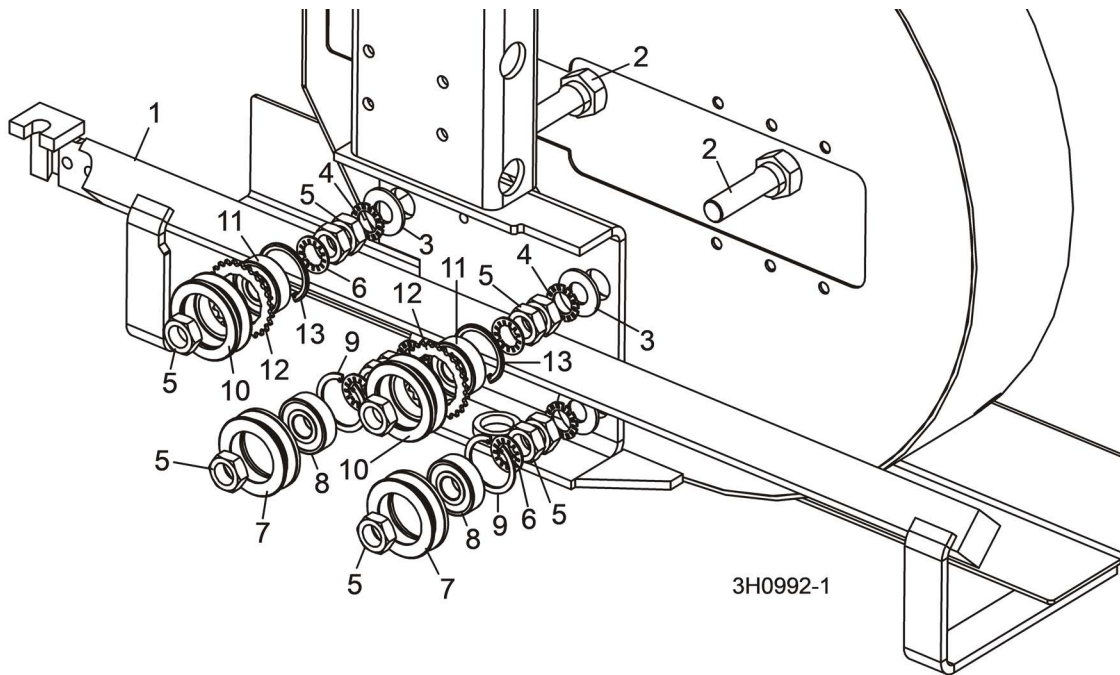

REF	PART #	DESCRIPTION	COMMENTS	QTY.
1	003972	BLADE GUIDE ARM WELDMENT		1
	007040	BLADE GUIDE ARM WELDMENT (WIDE HEAD ONLY)		1
2	W09067	BOLT, BLADE GUIDE ARM ROLLER CAM		4
3	F05011-5	WASHER, 5/8" SAE FLAT		4
4	F05011-26	WASHER, 5/8" EXTERNAL STAR		4
5	F05010-11	NUT, 5/8-18 HEX JAM		12
6	F05011-25	WASHER, 5/8" INTERNAL STAR		8
	A09059	ROLLER ASSEMBLY, BLADE GUIDE ARM WITH BEARING		2
7	S07989	Roller, Blade Guide Arm V-Groove	Available in assemblies only.	1
8	P06030-1	Bearing, 6203-2NSL 5/8" I.D.	Available in assemblies only.	1
9	F04254-8	Ring, 1.575" ID Beveled 5002-156 Retaining		1
	A09932	ROLLER ASSEMBLY, BLADE GUIDE ARM WITH BEARING AND SPROCKET		2
10	S09930	Roller, Blade Guide Arm Drive	Available in assemblies only.	1
11	P06030-1	Bearing, 6203-2NSL 5/8" I.D.	Available in assemblies only.	1
12	S09931	Sprocket, #25 26-Tooth	Available in assemblies only.	1
13	F04254-8	Ring, 1.575" ID Beveled 5002-156 Retaining		1

## SECTION 3 BLADE WHEELS & TENSIONER

### 3.1 Blade Drive Assembly - D35 and G38 Engines

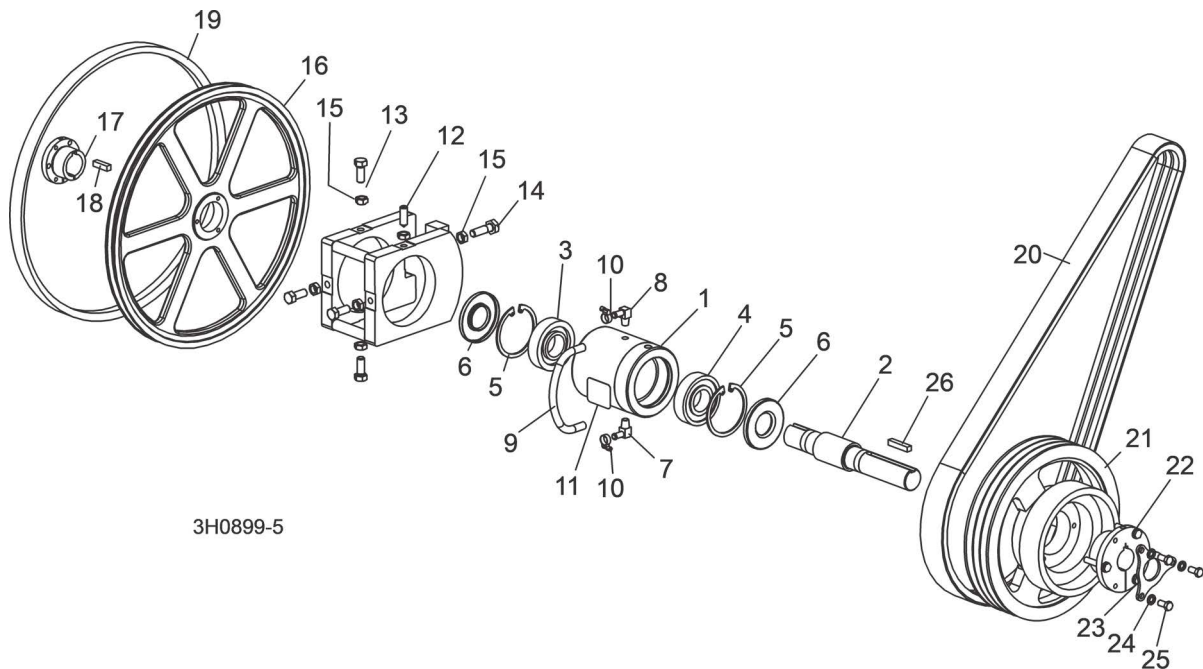

3H0899-5

REF	PART #	DESCRIPTION	COMMENTS	QTY.
	016393	<b>BEARING ASSEMBLY, BLADE WHEEL DRIVE</b>		1
	016392	Bearing Assembly, Cylindrical Drive	Available in assemblies only.	1
<b>1</b>	016391	Housing, Blade Wheel Drive Bearing	Available in assemblies only.	1
<b>2</b>	014005	Shaft, Blade Wheel Drive	Available in assemblies only.	1
<b>3</b>	P10205	Bearing, Blade Wheel Drive #MU1308TV		1
<b>4</b>	016055	Bearing, Blade Wheel Drive #6308 C3 Open		1
<b>5</b>	F04254-17	Ring, 90mm Interior Retaining #I17		2
<b>6</b>	P10206	Seal, Drive Bearing #CR15890		2
<b>7</b>	016330	Fitting, 1/4" NPT x 3/8" Hose Barb Elbow		1
<b>8</b>	016331	Fitting, 1/4" NPT x 3/8" Hose Barb Vented Elbow		1
<b>9</b>	016394	Hose, Oil Level Viewer		1
<b>10</b>	P649	Clamp, 7/32-5/8" Hose		2
<b>11</b>	017470	Decal, Oil Level Gauge		1
	016393-555	Instruction Sheet, Drive Bearing Replacement		1
<b>12</b>	F05004-170	<b>SCREW, 1/2-20 X 1 1/2" CONE POINT SET</b>		1
<b>13</b>	F05008-108	<b>BOLT, 1/2-20 X 1 1/4" HEX HEAD GRADE 5</b>		4
<b>14</b>	F05008-49	<b>BOLT, 1/2-20 X 1 3/4" HEX HEAD GRADE 5</b>		1
<b>15</b>	F05010-16	<b>NUT, 1/2-20 HEX JAM</b>		6
	014562	<b>WHEEL KIT, DRIVE SIDE BLADE</b>	Service Kit	1
<b>16</b>	016284	Wheel, Drive Side Blade	Available in assemblies only.	1
<b>17</b>	016270	Bushing, Modified 1 9/16" SD		1
<b>18</b>	S12892	Key, 3/8" x 3/8" x 1 5/8"		1



REF	PART #	DESCRIPTION	COMMENTS	QTY.
	K12897-488	Instruction Sheet, Drive Side Blade Wheel Replacement		1
<b>19</b>	P04185	<b>BELT, BLADE WHEEL B57</b>		1
<b>20</b>	06672	<b>BELT, 3/5VX750 THIN LAM</b>	<b>G38</b>	1
	110268	<b>BELT, 3/5VFL765 KEVLAR</b>	<b>D35</b>	1
	036163	<b>BELT, 2/BXF71 DRIVE</b>	<b>G26</b>	1
<b>21</b>	016531	<b>SHEAVE, 5V12.5X3 BRAKE COMBO</b>		1
<b>22</b>	016532	<b>BUSHING, SF X 1 9/16"</b>		1
<b>23</b>	017953	<b>PLATE, BUSHING KEY RETAINER</b>		1
<b>24</b>	F05011-4	<b>WASHER, 3/8" SPLIT LOCK</b>		3
<b>25</b>	F05007-27	<b>BOLT, 3/8-16 X 3/4" HEX HEAD</b>		3
<b>26</b>	014693	<b>KEY, 3/8" X 3/8" X 1 7/8"</b>		1

### 3.2 Blade Drive Assembly - G26 Engine

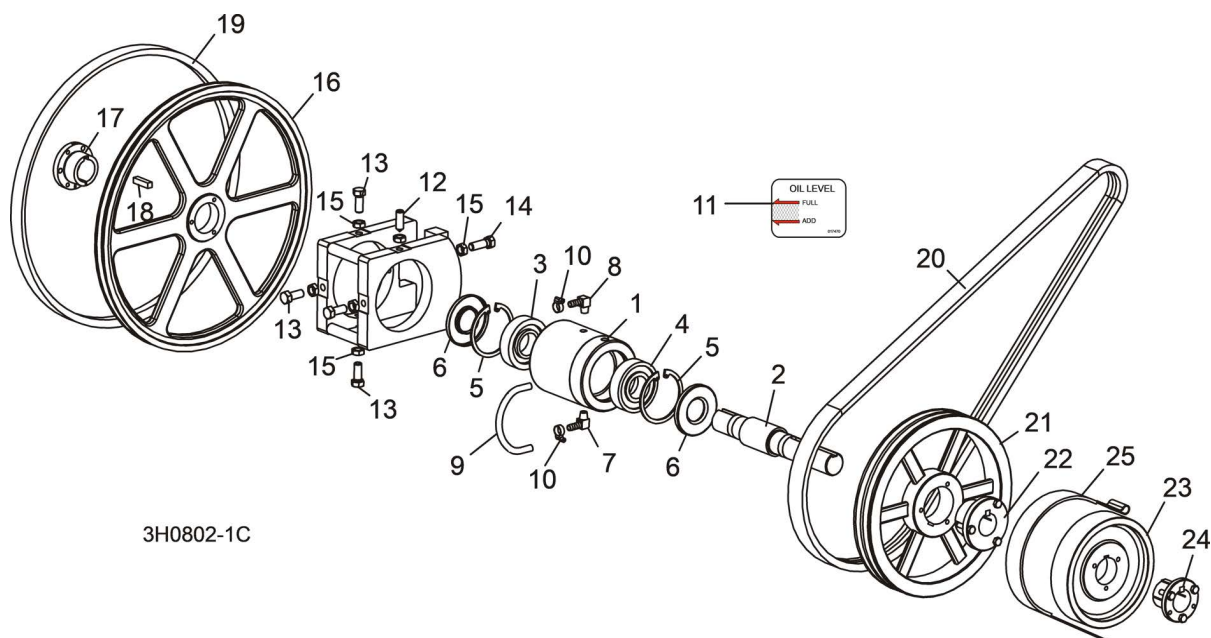

REF	PART #	DESCRIPTION	COMMENTS	QTY.
	016393	<b>BEARING ASSEMBLY, BLADE WHEEL DRIVE</b>		1
	016392	Bearing Assembly, Cylindrical Drive	Available in assemblies only.	1
<b>1</b>	016391	Housing, Blade Wheel Drive Bearing	Available in assemblies only.	1
<b>2</b>	014005	Shaft, Blade Wheel Drive	Available in assemblies only.	1
<b>3</b>	P10205	Bearing, Blade Wheel Drive #MU1308TV		1
<b>4</b>	016055	Bearing, Blade Wheel Drive #6308 C3 Open		1
<b>5</b>	F04254-17	Ring, 90mm Interior Retaining #117		2
<b>6</b>	P10206	Seal, Drive Bearing #CR15890		2
<b>7</b>	016330	Fitting, 1/4" NPT x 3/8" Hose Barb Elbow		1
<b>8</b>	016331	Fitting, 1/4" NPT x 3/8" Hose Barb Vented Elbow		1
<b>9</b>	016394	Hose, Oil Level Viewer		1
<b>10</b>	P649	Clamp, 7/32-5/8" Hose		2
<b>11</b>	017470	Decal, Oil Level Gauge		1
	016393-555	Instruction Sheet, Drive Bearing Replacement		1
<b>12</b>	F05004-170	<b>SCREW, 1/2-20 X 1 1/2" CONE POINT SET</b>		1
<b>13</b>	F05008-108	<b>BOLT, 1/2-20 X 1 1/4" HEX HEAD GRADE 5</b>		4
<b>14</b>	F05008-49	<b>BOLT, 1/2-20 X 1 3/4" HEX HEAD GRADE 5</b>		1
<b>15</b>	F05010-16	<b>NUT, 1/2-20 HEX JAM</b>		6
	014562	<b>WHEEL KIT, DRIVE SIDE BLADE</b>		1
<b>16</b>	016284	Wheel, Drive Side Blade	Available in assemblies only.	1
<b>17</b>	016270	Bushing, Modified 1 9/16" SD		1
<b>18</b>	S12892	Key, 3/8" x 3/8" x 1 5/8"		1
	K12897-488	Instruction Sheet, Drive Side Blade Wheel Replacement		1
<b>19</b>	P04185	<b>BELT, BLADE WHEEL B57</b>		1
<b>20</b>	036163	<b>BELT, 2/BXF71 DRIVE</b>	<b>G26</b>	1
	014692	<b>PULLEY KIT, 2B124SK DRIVE</b>	Service Kit	1

REF	PART #	DESCRIPTION	COMMENTS	QTY.
21	014689	Pulley, 2B124SK Drive	Available in assemblies only.	1
22	014690	Bushing, 1 9/16" Type 'SK'		1
	014693	Key, 3/8" x 3/8" x 1 7/8"		1
23	014000	<b>WHEEL, BRAKE</b>		1
24	014003	<b>BUSHING, 1 9/16" P1</b>		1
25	014391	<b>STRAP, METAL-BACKED BRAKE</b>		1

### 3.3 Idle Blade Wheel Assembly

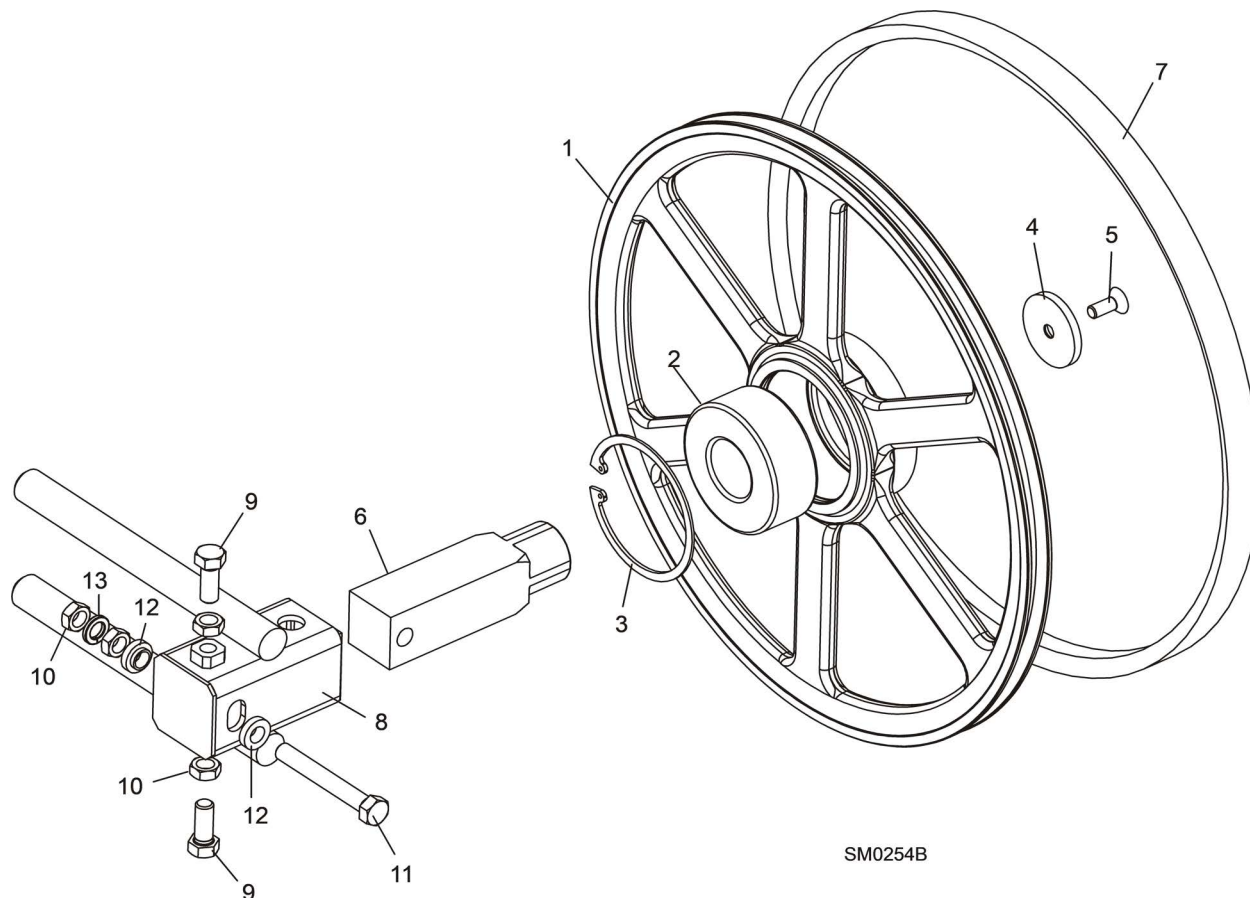

REF	PART #	DESCRIPTION	COMMENTS	QTY.
	016120	<b>WHEEL ASSEMBLY, IDLE SIDE BLADE</b>		1
1	016013	Pulley, Idle Side Ptd.	Available in assemblies only.	1
2	016014	Bearing, 5309-2RS		1
3	F04254-28	Ring, 100mm Internal Retaining Beveled		1
	016441	<b>SHAFT KIT, IDLE BLADE WHEEL</b>	Service kit	1
4	016397	Retainer, 13/32ID x 2 1/4OD x 1/4"		1
5	F05007-64	Bolt, 3/8-16 x 1" Flat Head Socket		1
6	016398	Shaft, 1 3/4 Idler, 3/8 Retainer		1
7	P04185	<b>BELT, BLADE WHEEL B57</b>		1
8	016103	<b>HOUSING, IDLE BLADE WHEEL SHAFT</b>		1
9	F05008-53	<b>BOLT, 1/2-20 X 1 1/2" HEX HEAD GRADE 5</b>		2
10	F05010-16	<b>NUT, 1/2-20 HEX JAM</b>		4
11	F05008-111	<b>BOLT, 1/2-20 X 3 3/4" HEX HEAD FULL THREAD GRADE 2</b>		1
12	S04253	<b>SPACER, 1/2" I.D. FLANGED</b>		2
13	F05011-9	<b>WASHER, 1/2" SPLIT LOCK</b>		1

### 3.4 Hydraulic Blade Tensioner Assembly

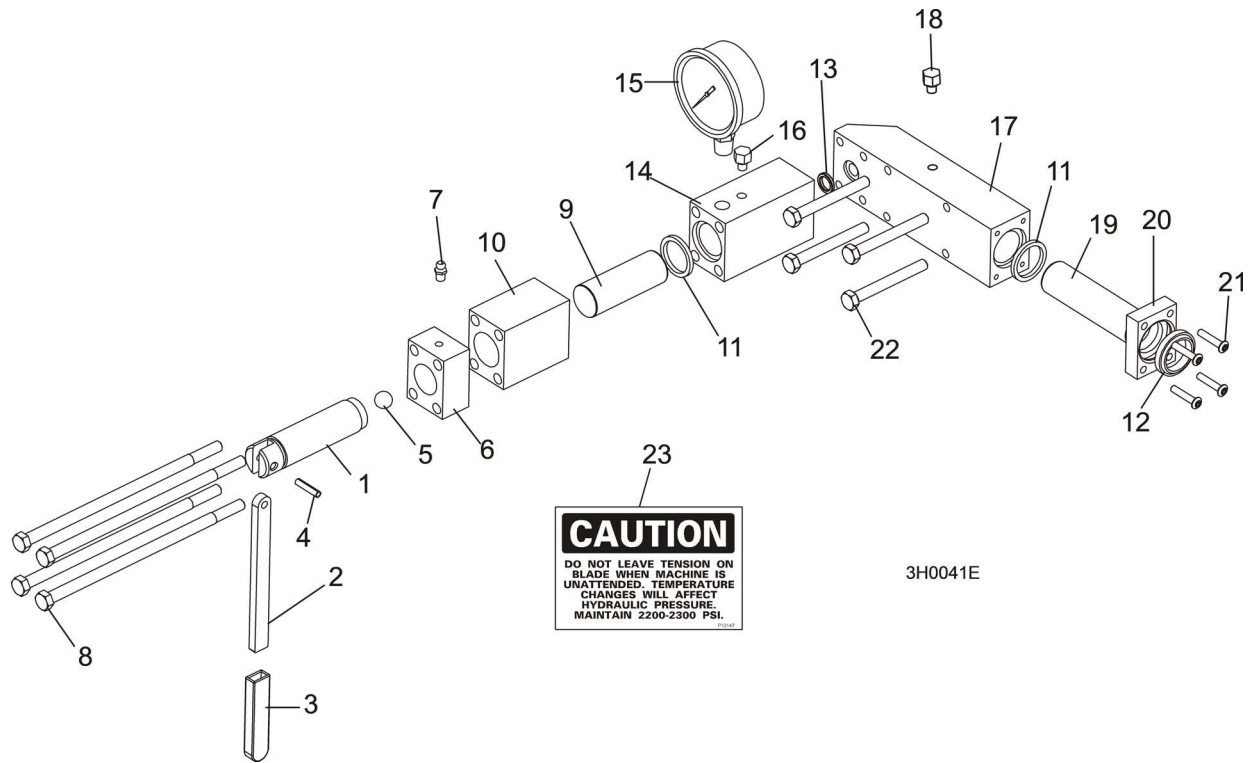

REF	PART #	DESCRIPTION	COMMENTS	QTY.
	A10136	<b>HYDRAULIC BLADE TENSIONER ASSEMBLY</b>	Service Kit	1
	A10054	Tensioner Assembly, Hyd Blade	Production assembly	1
	A12294	Handle Assembly, Hydraulic Blade Tensioner Screw	Service Kit	1
1	S10056	Screw, Hydraulic Blade Tensioner	Available in assemblies only.	1
2	S08174	Handle, Hydraulic Tensioner Screw		1
3	P08072	Sleeve, Plastic Handle		1
4	F05012-19	Pin, 3/16" x 7/8" Roll		1
5	P02720	Ball, 1/2" Steel		1
6	S10062	Block, Threaded Tensioner End	Available in assemblies only.	1
	P05060	Fitting, 1/4-28 Grease		1
	A12294-518	Instruction Sheet, Tensioner Screw		1
8	F05006-43	Bolt, 5/16-18 X 7 1/2" Hex Head Grade 5		4
9	S10060	Piston, Hydraulic Tensioner Front 2 3/4" Long		1
10	S10061	Block, Piston Guide		1
	003224	Seal Kit, Hydraulic Tensioner		1
5	P02720	Ball, 1/2" Steel		1
11	P10051	Seal, 1" Diameter		2
12	P10053	Wiper, 1" Diameter		1
13	P10377	Ring, 5/8" X 3/32" Square "O"		1
14	S10140	Block, Hydraulic Tensioner Gauge Mounting		1
15	P10052	Gauge, 3000 P.S.I. Hydraulic		1
16	P10065	Plug, Hydraulic Tensioner Fill		1
	016329	Block Assembly, Rear Tensioner Piston		1
17	S10142	Block, Rear Tensioner Piston	Available in assemblies only.	1

REF	PART #	DESCRIPTION	COMMENTS	QTY.
18	P10065	Plug, Hydraulic Tensioner Fill		1
19	S10059	Piston, Hydraulic Tensioner Rear 3 5/8" Long		1
20	S10089	Block, Rear Piston End		1
21	F05004-43	Bolt, #10-24 X 1" Socket Button Head		4
22	F05006-28	Bolt, 5/16-18 X 2 3/4" Hex Head Grade 5		4
23	P10147	Decal, Hydraulic Tension Caution		1
	A10136-272	Instruction Sheet, Hydraulic Tensioner Installation		1

## SECTION 4 SAW HEAD FRAME

### 4.1 Middle Throat Screw

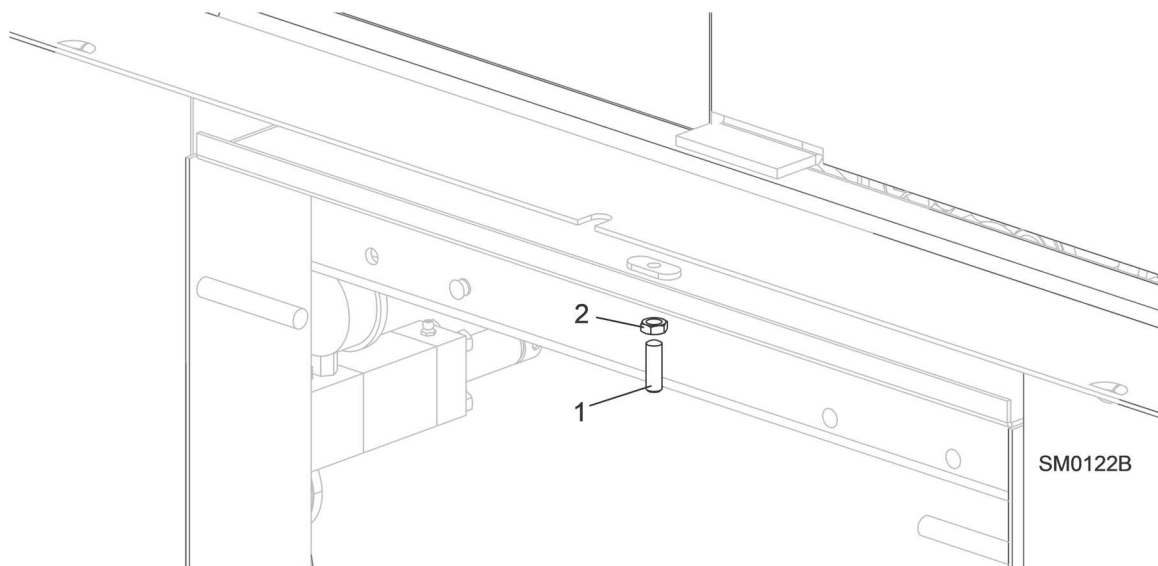

REF	PART #	DESCRIPTION	COMMENTS	QTY.
1	F05007-18	SCREW, 3/8-16 X 1 1/4" OVAL POINT SOCKET SET		1
2	F05010-29	NUT, 3/8-16 HEX JAM		1

## 4.2 Water Lube Solenoid Valve

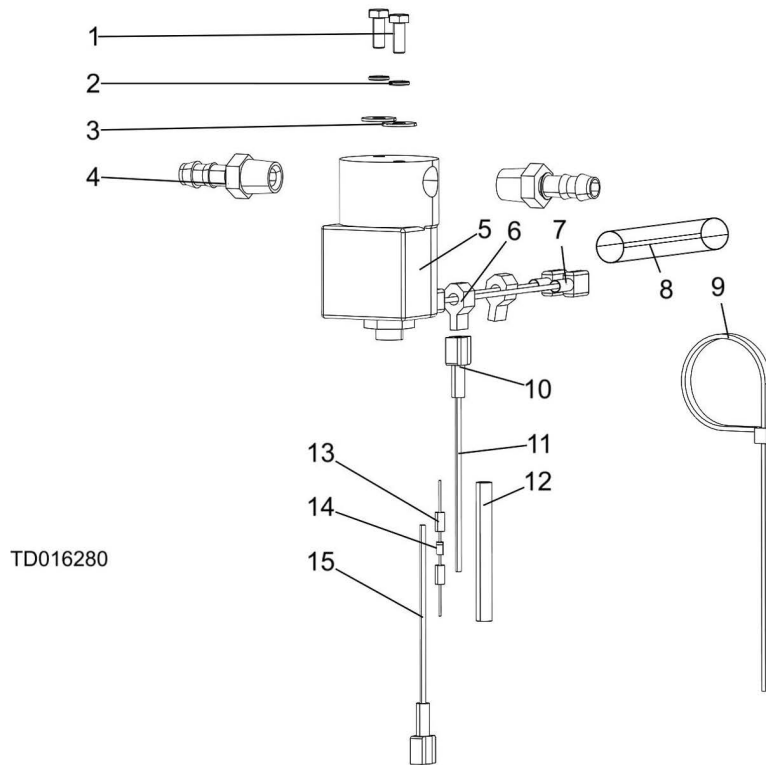

REF	PART #	DESCRIPTION	COMMENTS	QTY.
	016280	Solenoid Valve, Water Lube Kit		1
1	F05004-60	Bolt, #10-32x1/2 HH		2
2	F05011-20	Washer, #10 Split Lock		2
3	F05011-18	Washer, #10 SAE Flat		2
4	P04682	Fitting, 3/8 Barb 1/4NPT Male		2
	133071	Assembly, Water Lube Solenoid Electrical		1
5	016140	Solenoid Valve, 2-Way NC 1/4 Port 12 VDC		1
6	F04875-13	Connector, TT-Tap 14-16Awg		2
7	F05708-21R	Terminal, 1/4 18-22Ga Quick Female FI		2
8	R02374	Conduit, 1/2" Flex Loom		1
9	F05089-3	Tie Wrap, 3/16x5 1/2 UV Blk		1
	024123	Diode Assembly, Inductive Kick Protection		1
10	F05708-22R	Terminal, 1/4 18-22 Ga Qk Male FI Reel		2
11	R01915-3_3	Wire, 18AWG Stranded Red GXL		1
12	R01950-4_2_14	Tubing, 1/4" IDx2.25 Heat Shrink		1
13	024032	Conn, 14-16 AWG Parallel Splice		2
14	E05909	DIODE, 1N4003		1
15	R01915-0_3	Wire, 18AWG Stranded Black		1



### 4.3 Clutch Pivot

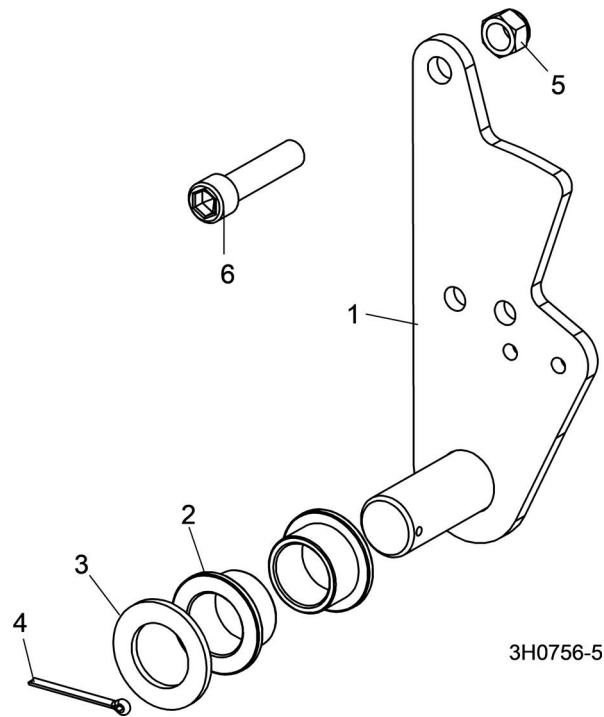

REF	PART #	DESCRIPTION	COMMENTS	QTY.
1	016296	Plate Weldment, Clutch Pivot		1
2	P737	Bushing, Clutch/Brake Pivot		2
3	P116	Washer, Clutch/Brake Pivot		1
4	F05012-49	Pin, 1/8" X 1 1/2" Cotter		1
5	F05010-83	Nut, 7/16-20 Hex Nylon Lock		1
6	F05007-120	Bolt, 7/16-20 x 2" Socket Head		1

## 4.4 Clutch Mount Assembly

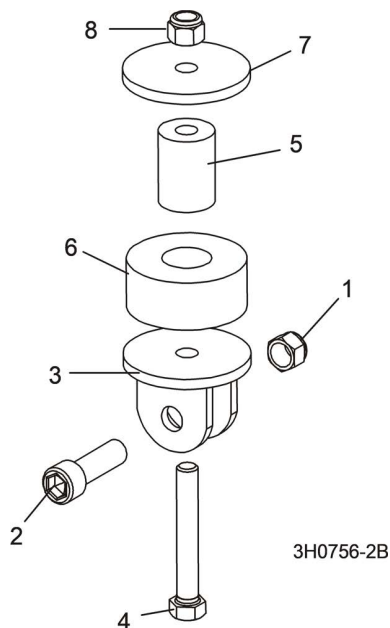

REF	PART #	DESCRIPTION	COMMENTS	QTY.
1	F05010-83	NUT, 7/16-20 HEX NYLON LOCK		1
2	F05007-55	BOLT, 7/16-20 X 1 1/2" SOCKET HEAD		1
3	W12411	BRACKET, CLUTCH MOUNT		1
4	F05007-157	BOLT, 3/8-16 X 2 1/2" HEX HEAD		1
5	016316	SPACER, MOTOR MOUNT VIBRATION BUSHING		1
6	P05032	BUSHING, MOTOR MOUNT VIBRATION		1
7	021276	WASHER, .40" I.D. X 1.44" O.D. X .18" THICK		1
8	F05010-10	NUT, 3/8-16 NYLON LOCK		1

## 4.5 Brake Assembly

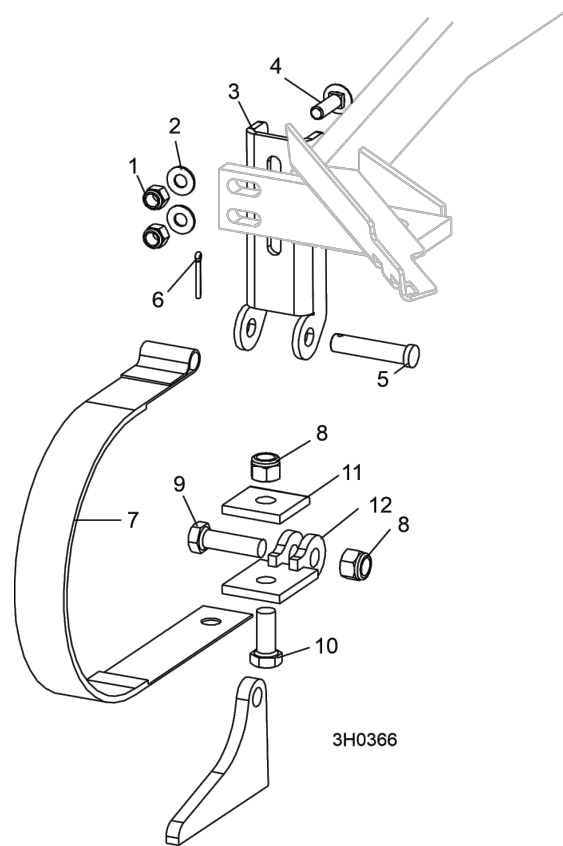

REF	PART #	DESCRIPTION	COMMENTS	QTY.
	014441	Strap Retrofit, Super Brake	Service Kit	1
1	F05010-10	Nut, 3/8-16 Nylon Lock		2
2	F05011-3	Washer, 3/8" SAE Flat		2
3	014395	Bracket, Upper Super Brake Strap Mount		1
4	F05007-127	Bolt, 3/8-16 x 1 1/4" Carriage Head Grade 5		2
5	F05012-81	Pin, 1/2" x 2 1/4" Clevis		1
6	F05012-1	Pin, 1/8" x 1" Cotter		1
7	014391	Strap, Upper Pivot Metal Brake		1
8	F05010-8	Nut, 1/2-13 Nylon Lock		2
9	F05008-33	Bolt, 1/2-13x1 1/2 HH Gr5		1
10	F05008-37	Bolt, 1/2-13 x 1 1/4" Hex Head Grade 5		1
11	S04195	Plate, Brake Strap Clamp		1
12	014392	Bracket, Lower Super Brake Strap Mount		1

## 4.6 Water Lube Assembly (2024-Present)

Used on all trays

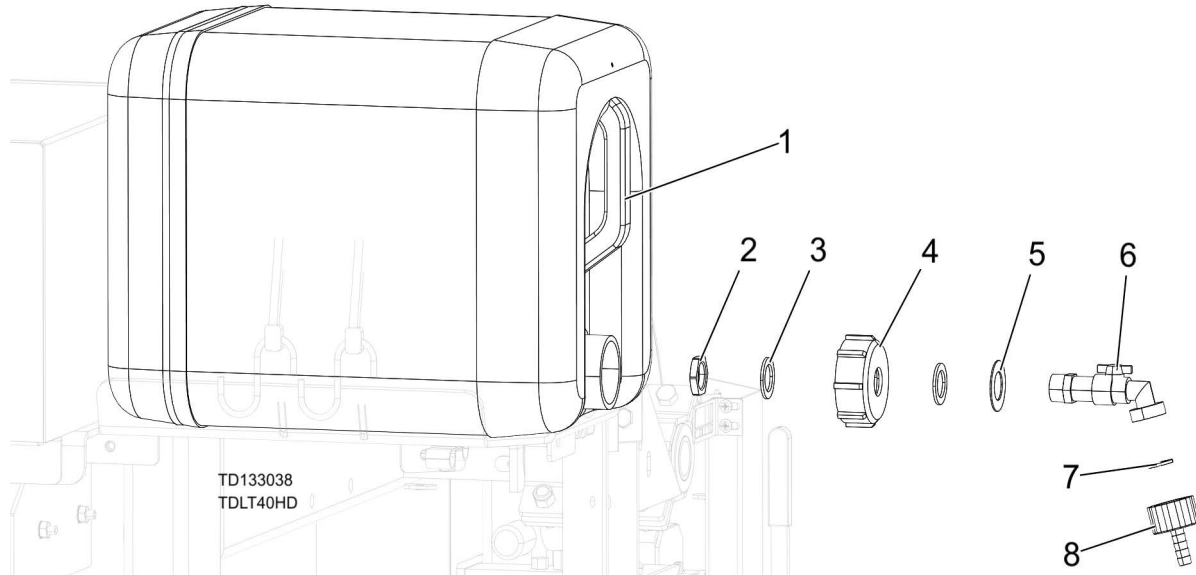

REF	PART #	DESCRIPTION	COMMENTS	QTY.
	550787	Assembly, Water Bottle		1
1	513866	Bottle, Water		1
2	550779	Gland Nut, 1/2 NPT		1
3	550780	O-ring, 27x20x1.5		2
4	550785	Cap. Water Bottle		1
5	530841	Shim, 21/37-1		1
6	550776	Fitting, Water Lube Shutoff Valve		1
7	550778	Gasket, 1/2 (Batard)		1
8	550777	Fitting, G3/4" X 10mm Hose Barb		1

## 4.7 Water Lube Assembly (2019-2024, Used on all trays)

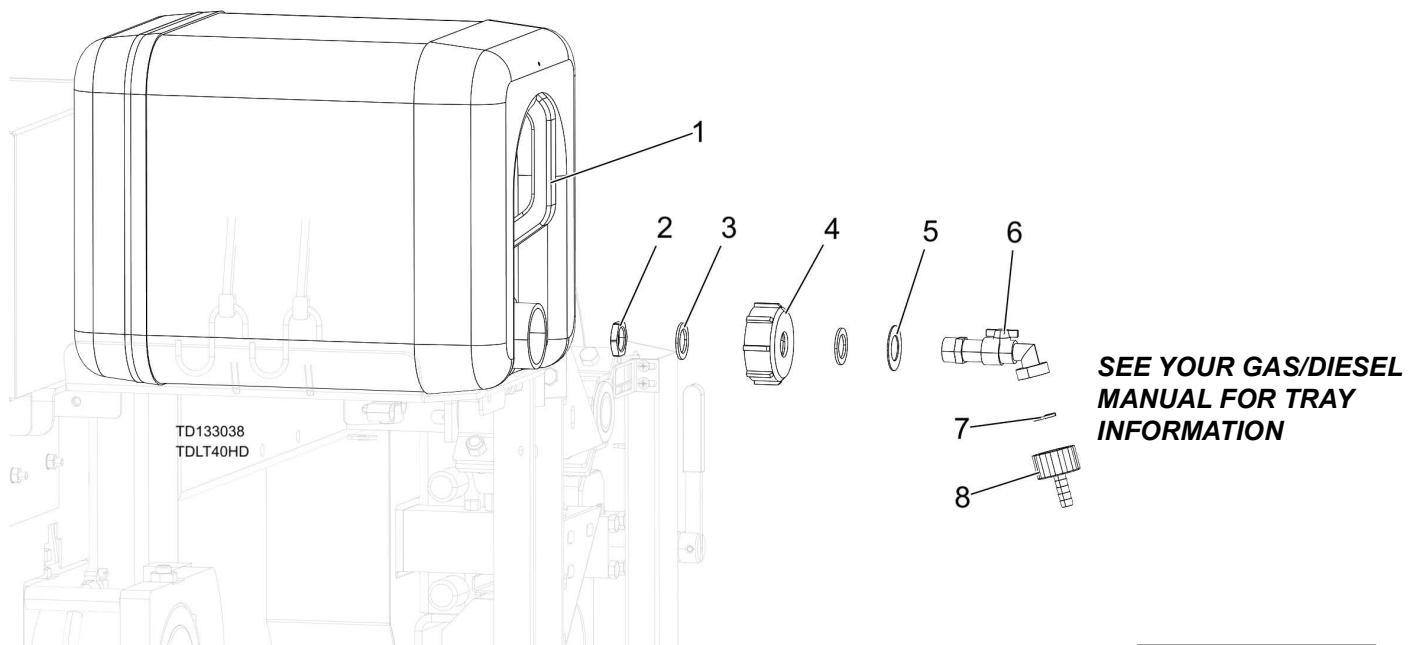

REF	PART #	DESCRIPTION	COMMENTS	QTY.
	550787	Assembly, Water Bottle		1
1	513866	Bottle, Water		1
2	550779	Gland Nut, 1/2 NPT		1
3	550780	O-Ring, 27x20x1.5		2
4	550785	Cap, Water Bottle		1
5	530841	Shim, 21/37-1		1
6	550776	Fitting, Water Lube SHutoff Valve		1
7	550778	Gasket, 1/2 (Batard)		1
8	550777	Fitting, G3/4" x 10mm Hose Barb		1
	110731	Bottle Kit, 5 Gallon Water	Replaced by 550787 after 1/29/2024 per ECN 39290.	1
	014642	Bottle Assembly, Water Lube w/Cap	Service parts	1
	061372	O-ring, Water Bottle Cap	If the cap leaks, add this o-ring to the cap, leaving the existing o-ring installed.	1
	014636	Fitting, 3/4 FPT x 3/4 MPT	Deleted after 9/19/2022 per ECN 38718.	1
	133320	Valve, 3/4 NPT Elbow 3/4 Male GHT Outlet	Replaced 014100 after 9/16/2022 per ECN 38718.	1
	014100	Valve, 3/4 NPT Elbow 3/4 Male GHT Outlet		1
	016086	Filter, Water Lube	Service parts	1
	014113	Fitting, 5/8" NPT to 3/8" Hose Barb	Service parts	1
	R01885	Tubing, Water Lube 3/8" I.D.	Not Shown	7 ft.
	CBOTTLE	Cover, 5 gal. Water Bottle	<b>OPTIONAL</b> -- Not Shown	1

## 4.8 Water Lube/Fuel Tray Assembly (2015, Gas Only)

LT40 Prior to K4.06-K4.08  
 LT40 Super Rev. J7.16-J7.17  
 LT40HD Rev. K6.07-K6.09  
 LT40HD Super Rev. K3.15-K3.17  
 LT50HD Rev. A5.15-A5.17

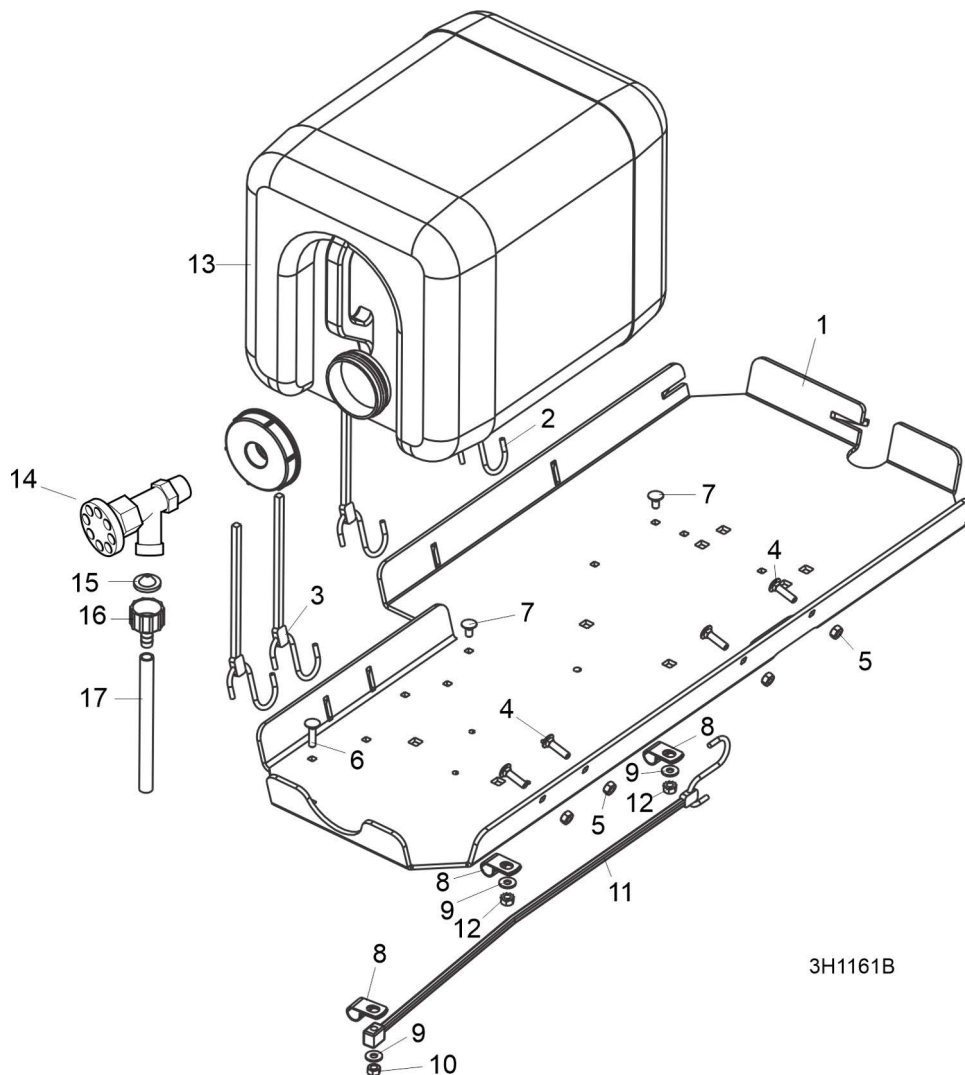

3H1161B

REF	PART #	DESCRIPTION	COMMENTS	QTY.
	076482	Tray Assembly, 5-gallon Gas Tank/water Bottle	Replaced A11685 Fuel Tank/Water Bottle Tray Assembly (See Section 4.8) to accommodate new gas tank meeting regulation standards (LT40 Rev. K4.06LT40Super Rev. J7.16LT40HD Rev. K6.07LT40HD Super Rev. K3.15LT50 Rev. A5.15).	1
1	076484	Tray, Fuel Tank/Water Bottle		1
2	P11668	Strap, 20" Rubber		2
3	P11668	Strap, 20" Rubber		2
4	F05005-34	Bolt, 1/4-20 X 1" Carriage Head		4

REF	PART #	DESCRIPTION	COMMENTS	QTY.
5	F05010-21	Nut, 1/4-20 Hex Lock		4
6	F05005-34	Bolt, 1/4-20 X 1" Carriage Head		1
7	F05005-33	Bolt, 1/4-20 X 1/2" Carriage Head		2
8	P07584	Clamp, 1/2" Emt Hose		3
9	F05011-11	Washer, 1/4" Sae Flat		3
10	F05010-21	Nut, 1/4-20 Hex Lock		1
11	P07461	Strap, 15" Rubber		1
12	F05010-9	Nut, 1/4-20 Self-locking		2
13	014642	Bottle Assembly, Water Lube W/cap	Separate from tray	1
	061372	O-ring, Water Bottle Cap	If the water bottle cap keeps leaking, add this o-ring to the cap. Leave the existing o-ring installed.	1
	014636	Fitting, 3/4fpt X 3/4mpt	Deleted after 9/19/2024 per ECN 38718.	1
14	133320	Valve, 3/4 NPT Elbow 3/4 Male GHT Outlet	Replaced 014100 after 9/19/2022 per ECN 38718.	1
	014100	Fitting, Water Lube Shutoff Valve		1
15	016086	Filter, Water Lube		1
16	014113	Fitting, 5/8" Npt To 3/8" Hose Barb		1
17	R01885	Tubing, Water Lube 3/8" I.d.		7 ft.
	CBOTTLE	Cover, 5 Gal. Water Bottle Optional (Not Shown)		1

### 4.9 Water Lube Assembly (All prior to 2015 - Electric Only after 2015)

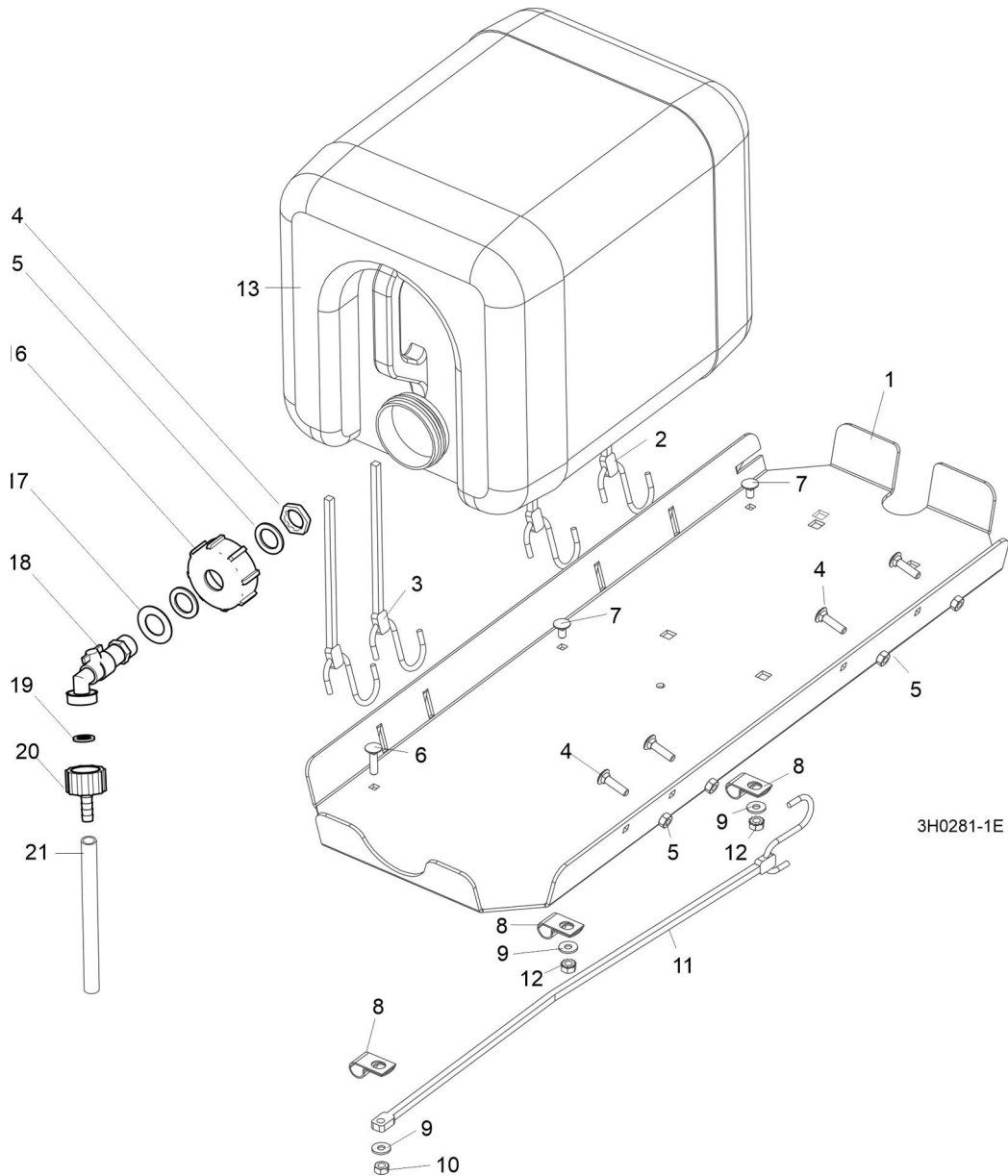

REF	PART #	DESCRIPTION	COMMENTS	QTY.
	A11685	<b>TRAY ASSEMBLY, FUEL TANK/WATER BOTTLE</b>		1
1	S11684	Tray, Fuel Tank/Water Bottle		1
2	P11258	Strap, 24" Rubber (For Fuel Tank - See Engine Manual)		2
3	P11668	Strap, 20" Rubber		2
4	F05005-34	Bolt, 1/4-20 X 1" Carriage Head		4
5	F05010-21	Nut, 1/4-20 Hex Lock		4
6	F05005-34	<b>BOLT, 1/4-20 X 1" CARRIAGE HEAD</b>		1
7	F05005-33	<b>BOLT, 1/4-20 X 1/2" CARRIAGE HEAD</b>		2
8	P07584	<b>CLAMP, 1/2" EMT HOSE</b>		3
9	F05011-11	<b>WASHER, 1/4" SAE FLAT</b>		3



REF	PART #	DESCRIPTION	COMMENTS	QTY.
10	F05010-21	<b>NUT, 1/4-20 HEX LOCK</b>		1
11	P07461	<b>STRAP, 15" RUBBER</b>		1
12	F05010-9	<b>NUT, 1/4-20 SELF-LOCKING</b>		2
	550787	Assembly, Water Bottle	Replaced 014642, 061372, 133320 & 014113 after 1/29/2024 per ECN 39290.	1
13	513866	Bottle, Water		1
14	550779	Gland Nut, 1/2 NPT		1
15	550780	O-Ring, 27x20x1.5		1
16	550785	Cap, Water Bottle		1
17	530841	Shim, 21/37-1		1
18	550776	Fitting, Water Lube Shutoff Valve		1
19	550778	Gasket, 1/2(Batard)		1
20	550777	Fitting, G3/4" x 10mm Hose Barb		1
	014642	<b>BOTTLE ASSEMBLY, WATER LUBE W/CAP</b>		1
	061372	O-ring, Water Bottle Cap	If the water bottle cap keeps leaking, add this o-ring to the cap. Leave the existing o-ring installed.	1
	014636	<b>FITTING, 3/4FPT X 3/4MPT</b>	Deleted after 9/19/2022 per ECN 38718.	1
	133320	Valve, 3/4 NPT Elbow 3/4 Male GHT Outlet	Replaced 014100 after 9/19/2022 per ECN 38718.	1
	014100	<b>FITTING, WATER LUBE SHUTOFF VALVE</b>		1
	016086	<b>FILTER, WATER LUBE</b>	Filter recommended for LT50-Super models to prevent debris from entering water lube solenoid valve.	1
	014113	<b>FITTING, 5/8" NPT TO 3/8" HOSE BARB</b>	No longer available	1
21	R01885	<b>TUBING, WATER LUBE 3/8" I.D.</b>		7 ft.

### 4.10 Fuel Tray (Gasoline)

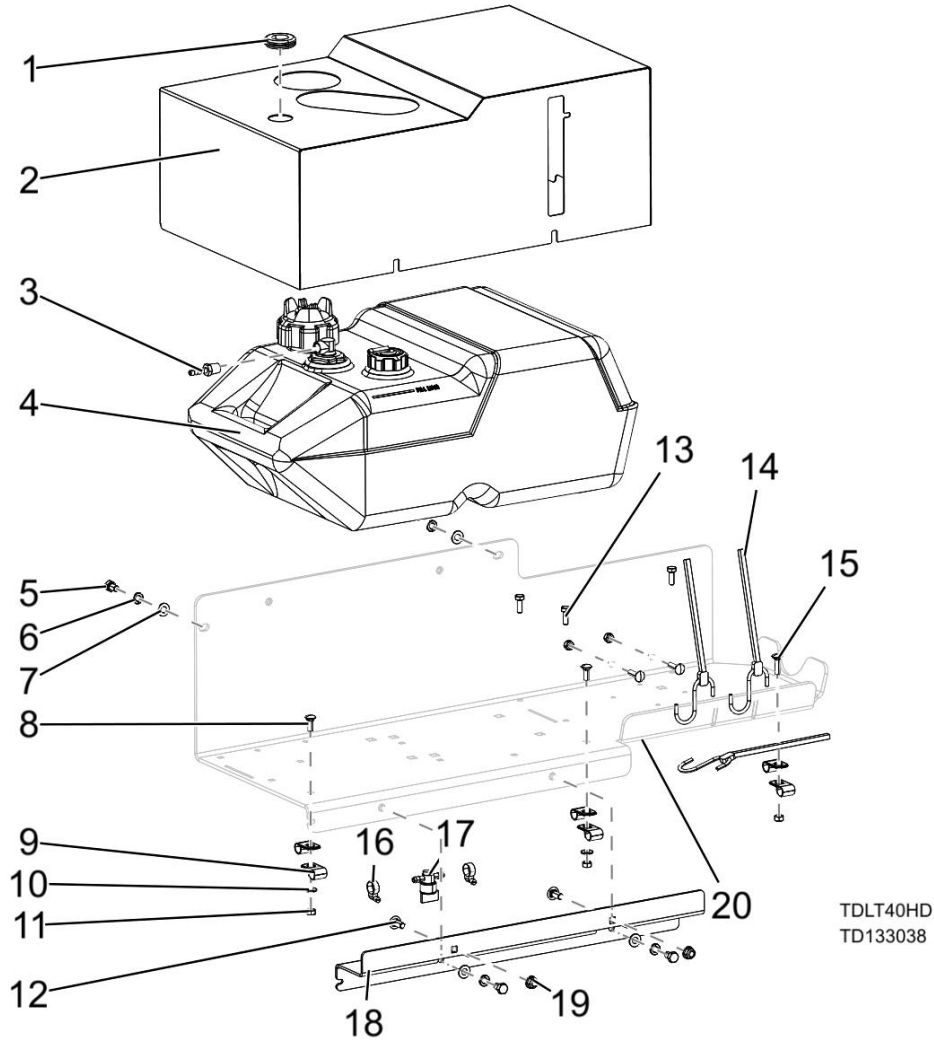

TDLT40HD  
TD133038

REF	PART #	DESCRIPTION	COMMENTS	QTY.
1	P702	Grommet, 7/8In IDx1 1/4In Groove Dia		1
2	130288	Cover Weldment, Fuel Tank, Domestic		1
3	P05393	Barb, 1/4 Hose 1/4NPT		1
4	130286	Fuel Tank, Domestic 6 Gal		1
5	F05006-15	Bolt, 5/16-18x1/2 HH Gr5		4
6	F05011-13	Washer, 5/16 Split Lock		4
7	F05011-17	Washer, 5/16 SAE Flat		4
8	F05005-113	Bolt, 1/4-20x3/4 Carriage		2
9	P07584	Clamp, 1/2EMT Coated		6
10	F05011-11	Washer, 1/4 SAE Flat		2
11	F05010-21	Nut, 1/4-20 Swaged		5
12	F05006-86	Bolt, 5/16-18x3/4 Carriage		2
13	F05005-123	Bolt, 1/4-20x3/4 HH Gr5		3
14	P11668	Strap, 20 Rubber W/Hooks		3
15	F05005-34	Bolt, 1/4-20 X 1 Carr		3
16	P649	Hose Clamp, 7/32in-5/8in		2
17	P851	Valve, Fuel, In Line Shut Off		1
18	130283	Extension, Fuel Tray		1

<b>REF</b>	<b>PART #</b>	<b>DESCRIPTION</b>	<b>COMMENTS</b>	<b>QTY.</b>
<b>19</b>	F05010-221	Nut, 5/16-18 Flanged Hex Nylock		2
<b>20</b>	103943	Weldment, Fuel Tank LT40/50		1
	R02423-1	Hose, Fuel 3/16" EPA 15G CARB	Not shown	7.5ft
	R02423-2	Hose, Fuel 1/4" EPA 15G CARB	Not shown	6.8ft
	064654	Grommet, Remote Vent	Not shown	1
	064653	Remote Vent w/ Valve	Not shown	1

### 4.11 Fuel Tray (Diesel - US Only)

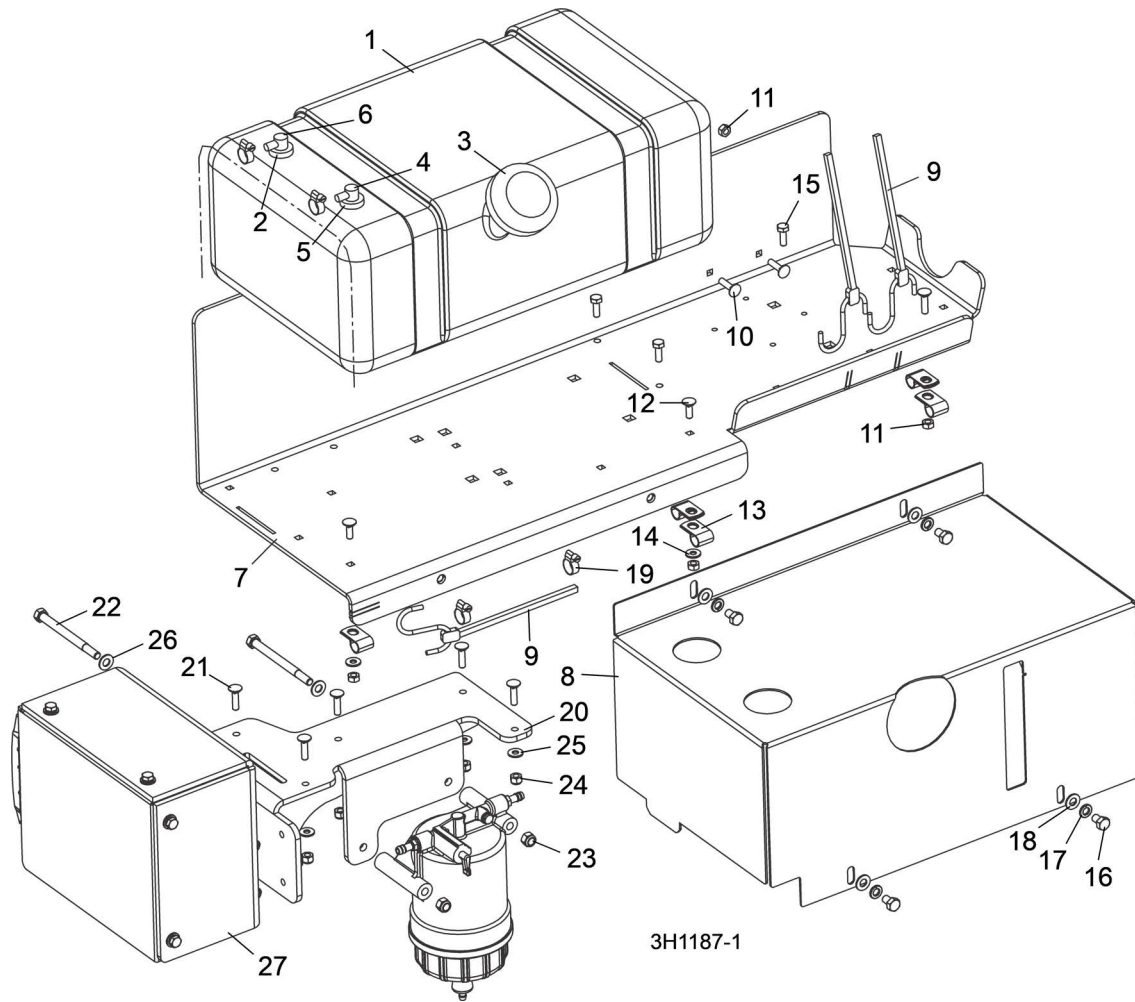

REF	PART #	DESCRIPTION	COMMENTS	QTY.
	079637	<b>TRAY ASSEMBLY, LT40/50 TIER4 DIESEL TANK</b>		1
1	103928	Tank, 5 Gallon Low Pro Diesel		1
2	061250	Grommet, Shut Off 046881		1
3	061257	Cap, Fuel Tank Diesel 080185BE		1
4	061256	Fitting, Return/tube Diesel 468489		1
5	061250	Grommet, Shut Off 046881		1
6	061255	Fitting, Pick-Up/Tube Diesel 468871A		1
7	103943	Tank Weldment, Fuel LT40/50		1
8	103867	Cover, Fuel Tank		1
9	P11668	Strap, 20" Rubber	Two for the water tank; one for the sawdust chute transport	3
10	F05005-34	Bolt, 1/4-20 X 1" Carriage Head		3
11	F05010-21	Nut, 1/4-20 Hex Lock		5
12	F05005-113	Bolt, 1/4-20 x 3/4" Carriage		2
13	P07584	Clamp, 1/2" EMT Coated		6
14	F05011-11	Washer, 1/4" SAE Flat		2
15	F05005-123	Bolt, 1/4-20 x 3/4" Hex Head Grade 5		3
16	F05006-15	Bolt, 5/16-18 x 1/2" Hex Head Grade 5		4
17	F05011-13	Washer, 5/16" Split Lock		4

REF	PART #	DESCRIPTION	COMMENTS	QTY.
18	F05011-17	Washer, 5/16" SAE Flat		4
19	P649	Hose Clamp, 7/32in-5/8in		4
	079409	Separator Assembly, D35 T4 ECU F/W		1
20	079471	Mount Weldment, D35 T4 ECU F/W Separator		1
21	F05005-34	Bolt, 1/4-20x1 Carriage		5
22	F05006-109	Bolt, 5/16-18x4 Hex Head Grade 5		2
23	F05010-58	Nut, 5/16-18 Nylok Hex		2
24	F05010-69	Nut, 1/4-20 Nylock		5
25	F05011-11	Washer, 1/4 SAE Flat		5
26	F05011-17	Washer, 5/16 SAE Flat		2
27	079422	Relays/Fuse Assembly, D35 T4 ECU	<i>(See Section 4.8) for Parts</i>	1
	R02423-3	Hose, Fuel 5/16" EPA 15G CARB		7.5Ft
	R02423-2	Hose, Fuel 1/4" EPA 15G CARB		8 Ft.

### 4.12 Fuel Tray (Diesel - International)

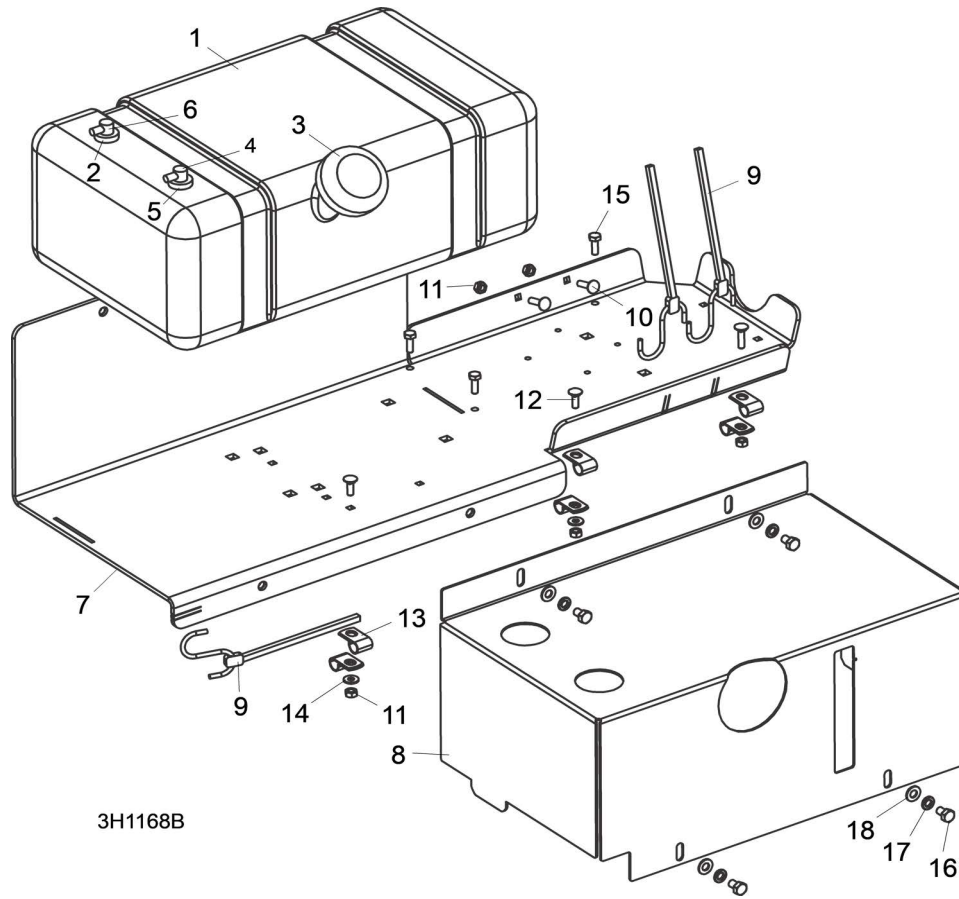

REF	PART #	DESCRIPTION	COMMENTS	QTY.
	074830	<b>TRAY ASSEMBLY, LT40/50 DIESEL TANK</b>		1
1	103928	Tank, 5 Gallon Low Pro Diesel		1
2	061250	Grommet, Shut Off 046881		1
3	061257	Cap, Fuel Tank Diesel 080185BE		1
4	061256	Fitting, Return/tube Diesel 468489		1
5	061250	Grommet, Shut Off 046881		1
6	061255	Fitting, Pick-Up/Tube Diesel 468871A		1
7	103943	Tank Weldment, Fuel LT40/50		1
8	103867	Cover, Fuel Tank		1
9	P11668	Strap, 20" Rubber	Two for the water tank; one for the sawdust chute transport	3
10	F05005-34	Bolt, 1/4-20 X 1" Carriage Head		3
11	F05010-21	Nut, 1/4-20 Hex Lock		5
12	F05005-113	Bolt, 1/4-20 x 3/4" Carriage		2
13	P07584	Clamp, 1/2" EMT Coated		6
14	F05011-11	Washer, 1/4" SAE Flat		2
15	F05005-123	Bolt, 1/4-20 x 3/4" Hex Head Grade 5		3
16	F05006-15	Bolt, 5/16-18 x 1/2" Hex Head Grade 5		4
17	F05011-13	Washer, 5/16" Split Lock		4
18	F05011-17	Washer, 5/16" SAE Flat		4
	R02423-3	Hose, Fuel 5/16" EPA 15G CARB		7 Ft.
	R02423-2	Hose, Fuel 1/4" EPA 15G CARB		8 Ft.

### 4.13 Saw Head Decals

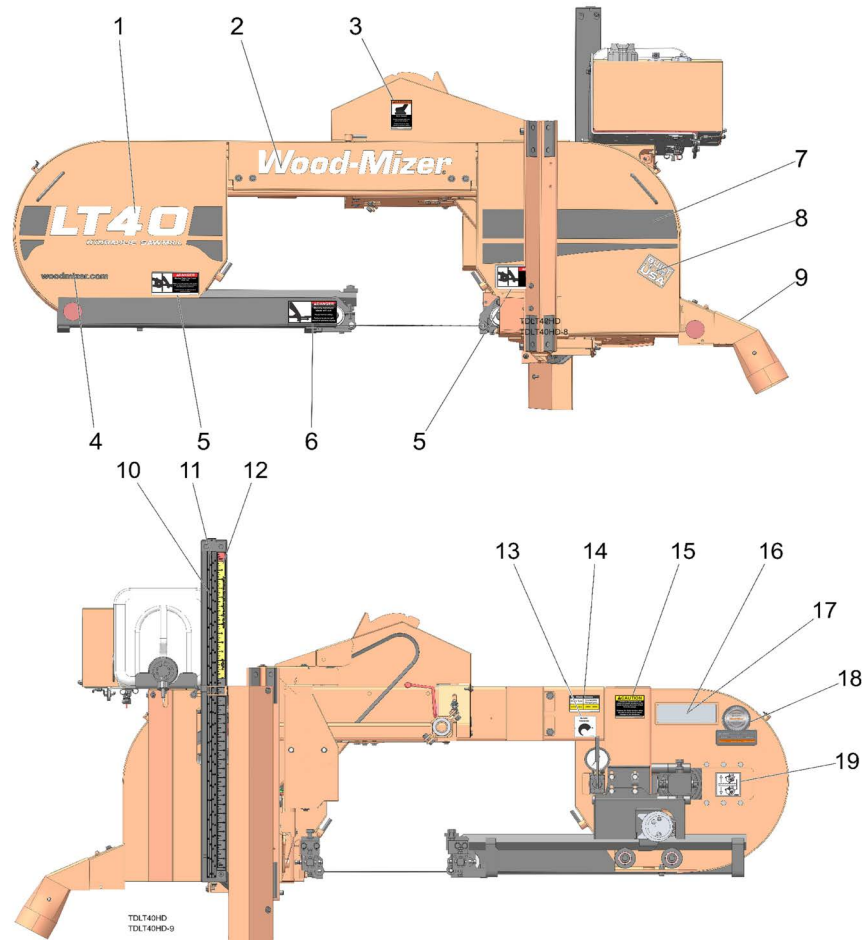

REF	PART #	DESCRIPTION	COMMENTS	QTY.
1	011201-LT40H	Decal, LT40 Hydro Idle Side		1
2	065034	Decal, Wood-Mizer Logo 20.5" White		2
3	014419	Decal, Hot Engine Warning		1
4	003235	Decal, Wood-Mizer Website Logo		1
5	033254	Decal, Moving Parts Danger		2
6	S11752	Decal, Blade Danger Arrow Right		1
7	011201-DRIVE	Decal, LT40 Standard Idle Side		1
8	074008	Decal, Built In The USA		1
9	P11754	Decal, Sawdust Chute Warning		1
10	S11774	Decal, Moveable Quarter Scale		1
11	P12819	Decal, 37 1/2 Grade Quarter		1
12	S11773	Decal, Moveable Inch Scale		1
13	P11790	Decal, Tension Screw		1
14	P12373	Decal, Blade Tension Ranges		1
15	P10147	Decal, Hyd Blade Tension Caution		1
16	P09943	Decal, VIN		2
17	P09971	Decal, VIN Overlayment		2
18	079278	Decal, Wood-Mizer Quality & Information		1
19	P11789	Decal, Blade Alignment		1

### 4.14 Blade Housing Covers

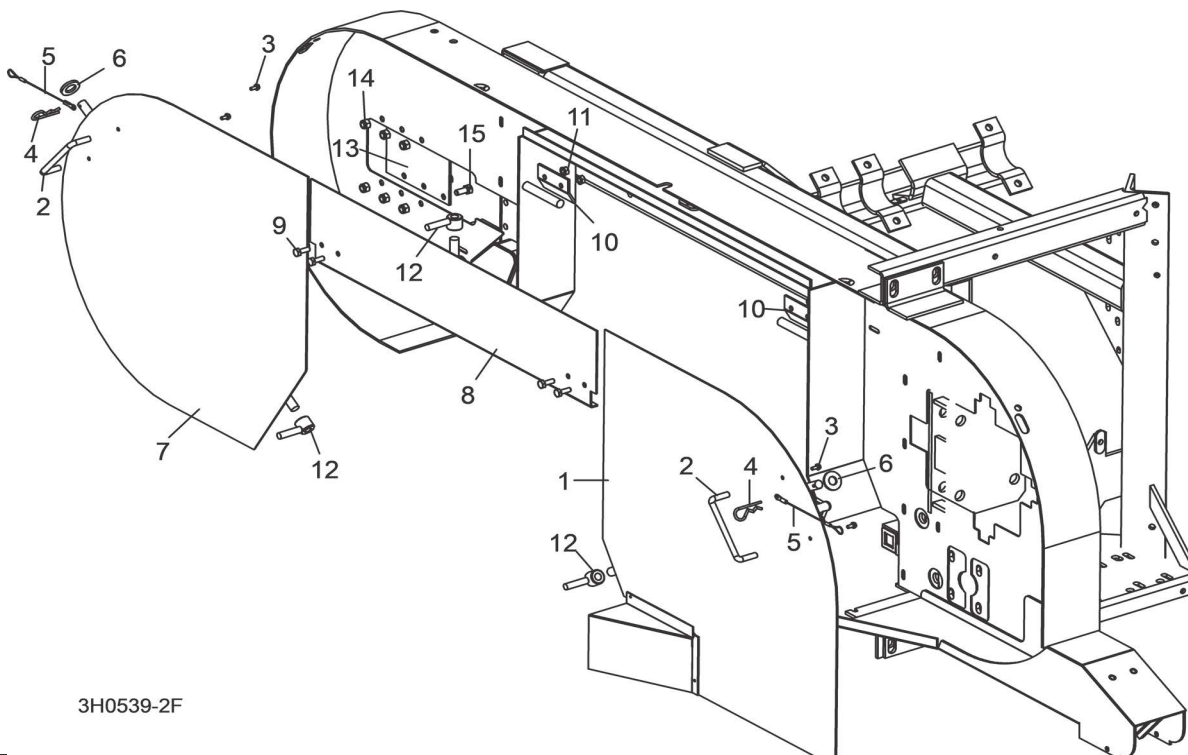

3H0539-2F

REF	PART #	DESCRIPTION	COMMENTS	QTY.
	015937	Cover Assembly, Drive Side Blade Housing With Handle		1
1	015911	Cover, Drive Side Blade Housing	Available in assemblies only. (Includes Decal 003235)	1
2	P08065	Handle, Blade Housing Cover		1
3	F05015-8	Screw, #8-32 X 3/8" Self-Tap		2
	A12812	Pin Assembly, Cover Retainer	Service assembly	1
4	P05059	Pin, Safety Retainer		1
5	016030	Cable, 3/64" x 6" Lanyard		1
6	F05011-87	Washer, 1/2" ID x 1 1/8" OD x .093" Rubber		1
	A09419	Cover, Idle Side Blade Housing With Handle		1
7	W09351	Cover, Idle Side Blade Housing	Available in assemblies only. (Includes Decal 003235)	1
	P08065	Handle, Blade Housing Cover	See items 2-6	1
	F05015-8	Screw, #8-32 X 3/8" Self-Tap		2
	A12812	Pin Assembly, Cover Retainer	Service assembly	1
	P05059	Pin, Safety Retainer		1
	016030	Cable, 3/64" x 6" Lanyard		1
	F05011-87	Washer, 1/2" ID x 1 1/8" OD x .093" Rubber		1
8	016247	Cover, Middle Blade Housing		1
	079509	Cover, Middle Blade Housing	(Wide Head Only)	1
9	F05005-1	Bolt, 1/4-20 X 3/4" Hex Head		18
10	S07522	Hinge, Middle Blade Housing Cover		2
11	F05010-9	Nut, 1/4-20 Self-Locking Hex		4
12	021145	Nut, Cover Turn		3
13	S04433	Plate, Idle Blade Wheel Guard		1
14	F05010-58	Nut, 5/16-18 Hex Nylon Lock		6
15	F05006-5	Bolt, 5/16-18 X 3/4" Hex Head Grade 2		6



## 4.15 Drive Belt Covers

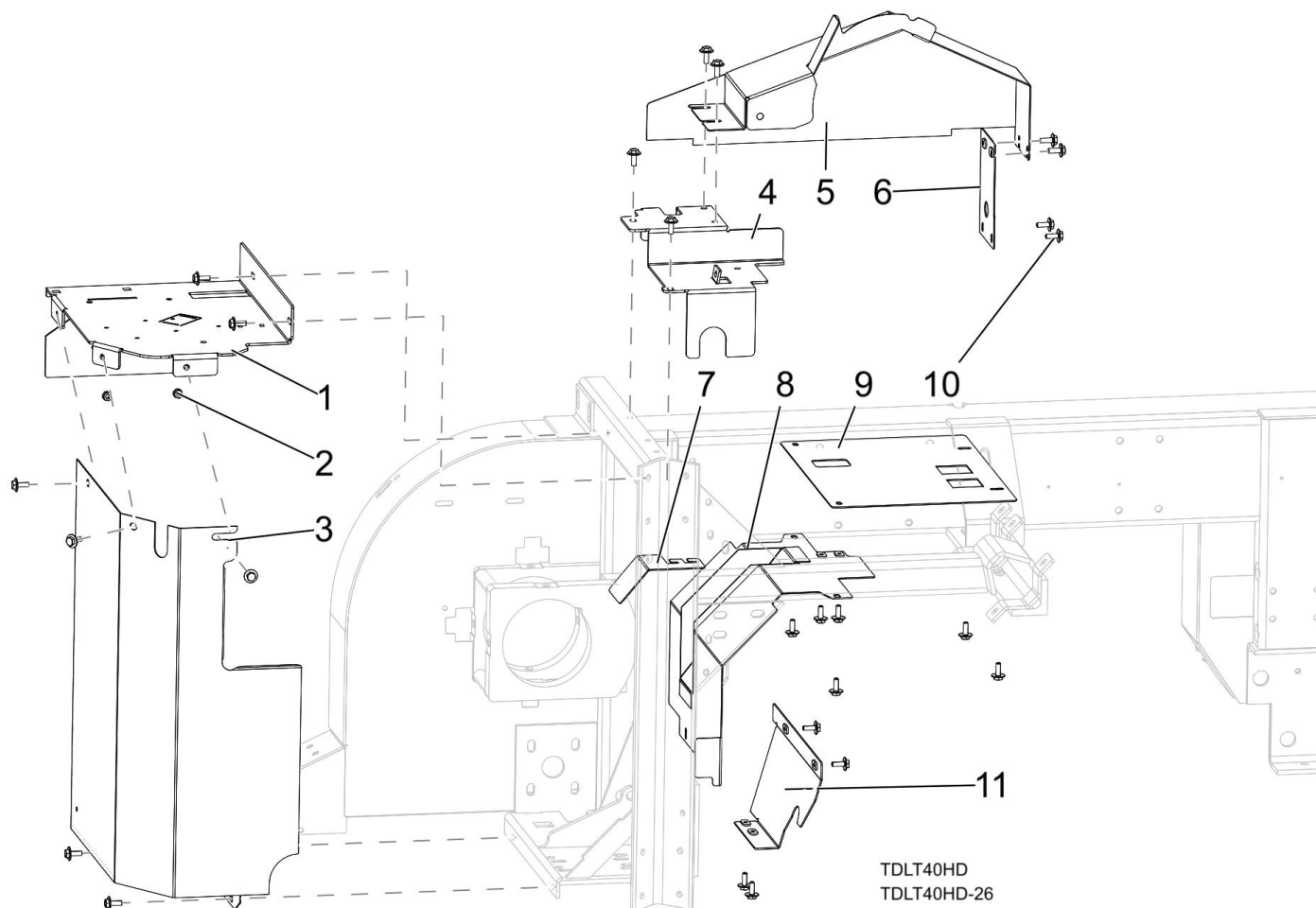

REF	PART #	DESCRIPTION	COMMENTS	QTY.
1	059599	Mount Weldment, Top Enclosure '10		1
2	F05010-9	Nut, 1/4-20 Keps		2
3	059596	Cover Weldment, C-Frame Enclosure '10		1
4	015962	Guard, Kohler Side Engine Pulley	G26 and G38 engines	1
	079714	Plate, D35 T4 Side Guard	D35 engine, US	1
	016152	Guard, Side Engine Pulley	D35 engine, International	1
5	003220	Cover Weldment, G38 Top Pulley	G38 engine	1
	079473	Cover Weldment, D35 T4 Top Pulley	D35 engine, US	1
	075542	Guard Weldment, Yanmar Engine Top Pulley	D35 engine, International	1
	015960	Guard Weldment, Kohler Engine Pulley	G26 engine	1
6	003263	Plate Weldment, G38 Gusset Cover	G38 engine	1
	079707	Plate, D35 T4 Cover	D35 engine, US	1
	015961	Guard, Kohler Bottom Engine Pulley	D26 engine	1
7	074752	Plate, LT40 Belt Cover		1
8	006026	Guard Weldment, Clutch 07		1
9	016089	Cover, Lower Belt Auto Clutch Std.		1
10	F05005-134	Bolt, 1/4-20x3/4 W/Conical Washer		27
11	006025	Guard Weldment, Lower Clutch, 07		1

### 4.16 Sawdust Chute

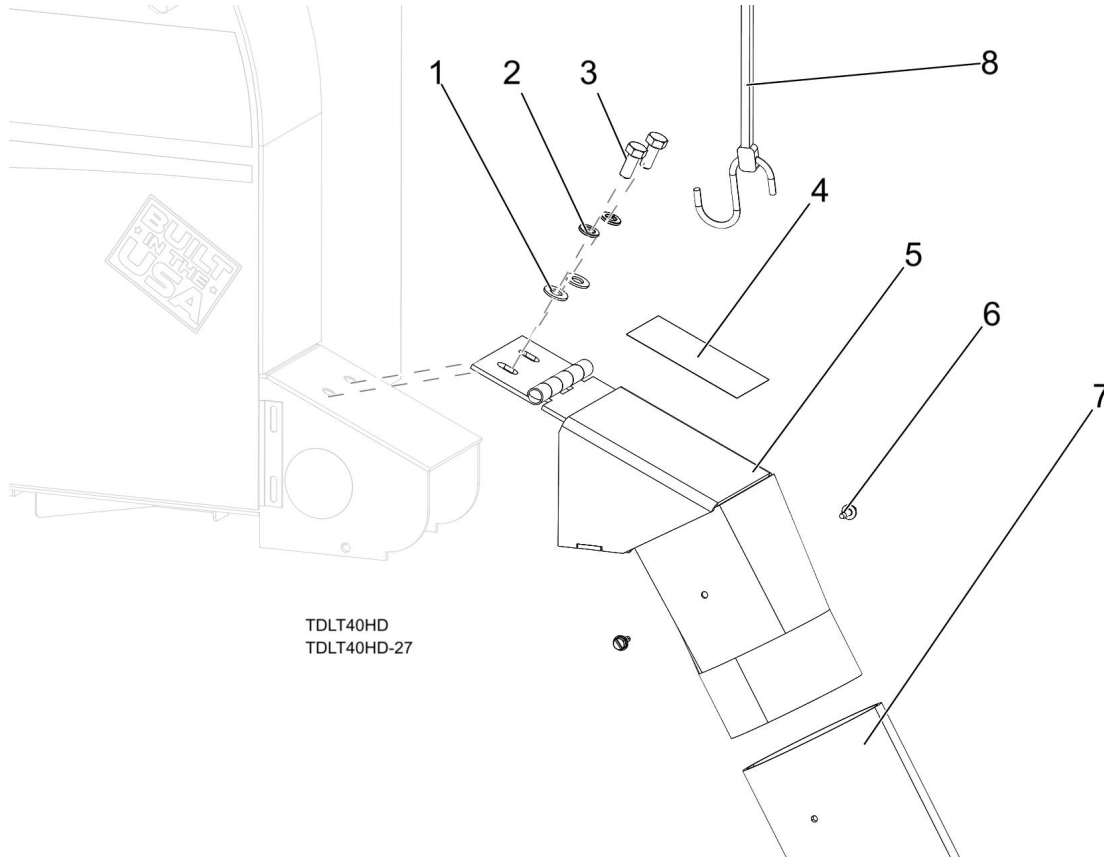

REF	PART #	DESCRIPTION	COMMENTS	QTY.
1	F05011-17	Washer, 5/16 SAE Flat		2
2	F05011-13	Washer, 5/16 Split Lock		2
3	F05006-5	Bolt, 5/16-18x3/4 HH Gr2		2
4	P11754	Decal, Sawdust Chute Warning		1
5	015466	Chute Weldment, 97 Sawdust		1
6	F05015-7	Bolt, #10-24x1/2 Self Tap		2
7	016727	Chute, Rubber Sawdust		1
8	P11668	Strap, 20 Rubber W/Hook	Located on fuel tray - used for transporting the chute	1

### 4.17 Board Return Assembly (Optional)

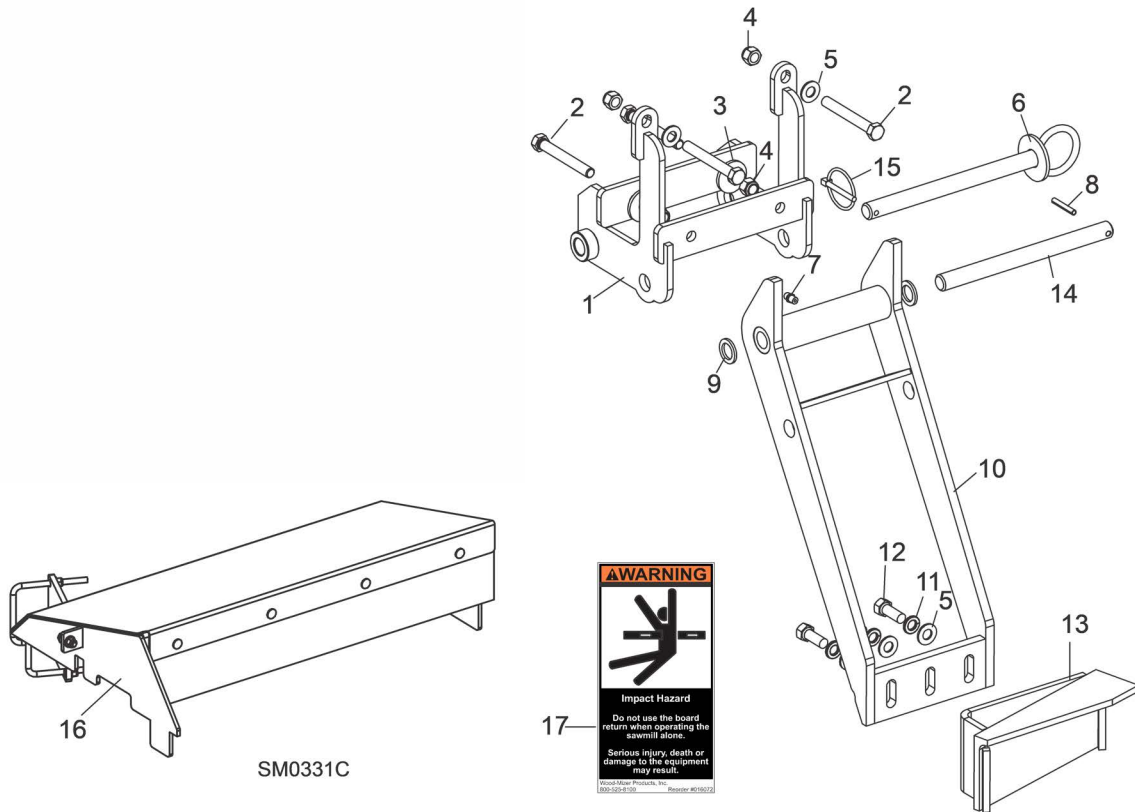

REF	PART #	DESCRIPTION	COMMENTS	QTY.
	MBR-A40	Return Option, Non-Super Board		1
	036693	Return Assembly, Optional Non-Super Board		1
1	036691	Mount Weldment, Board Return		1
2	F05007-1	Bolt, 3/8-16 x 3" Full Thread Hex Head		4
3	015336	Washer, 1/8" x 1 1/4"		2
4	F05010-10	Nut, 3/8-16 Hex Nylon Lock		4
5	F05011-3	Washer, 3/8" Flat		5
6	036692	Pin Weldment, Board Return Arm Support		1
7	P05060	Fitting, 1/4-28 Grease		1
8	F05012-16	Pin, 3/16 x 1 1/4" Roll		1
9	F05011-19	Washer, 5/8" x 15/16" x .094 Nylon		2
10	015210	Arm Weldment, Board Return		1
11	F05011-4	Washer, 3/8" Split		3
12	F05007-7	Bolt, 3/8-16 x 1" Hex Head		3
13	015652	Bracket Weldment, Board Return		1
14	015225	Rod, 5/8" x 7 5/8"		1
15	017604	Pin, 3/16" Retaining w/Chain		1
16	003264	Board Return Table Parts	<a href="#">(See Section 8.5)</a>	1
17	016072	Decal, Board Return Warning		1

### 4.18 Wire Box/Hole Plugs

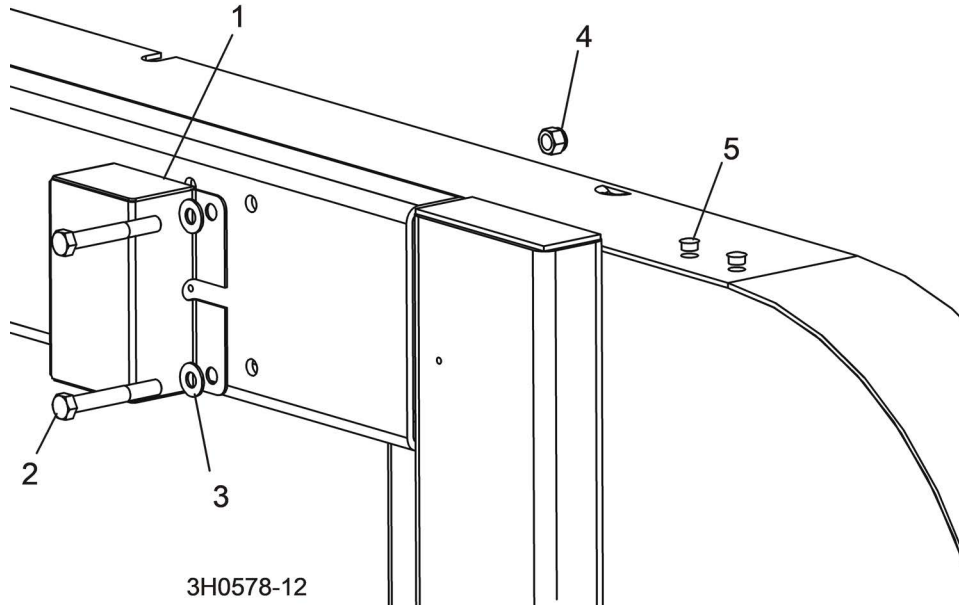

REF	PART #	DESCRIPTION	COMMENTS	QTY.
1	023616	Box, Wire Storage	Accesses debarker wiring	1
2	F05007-29	Bolt, 3/8-16 x 2 3/4" Hex Head		2
3	F05011-3	Washer, 3/8" SAE Flat		2
4	F05010-10	Nut, 3/8-16 Hex Nylon Lock		2
5	014537	Plug, 13/32" Plastic Hole		2

## SECTION 5 CONTROL & BATTERY BOXES

### 5.1 Control Assembly (Accuset)

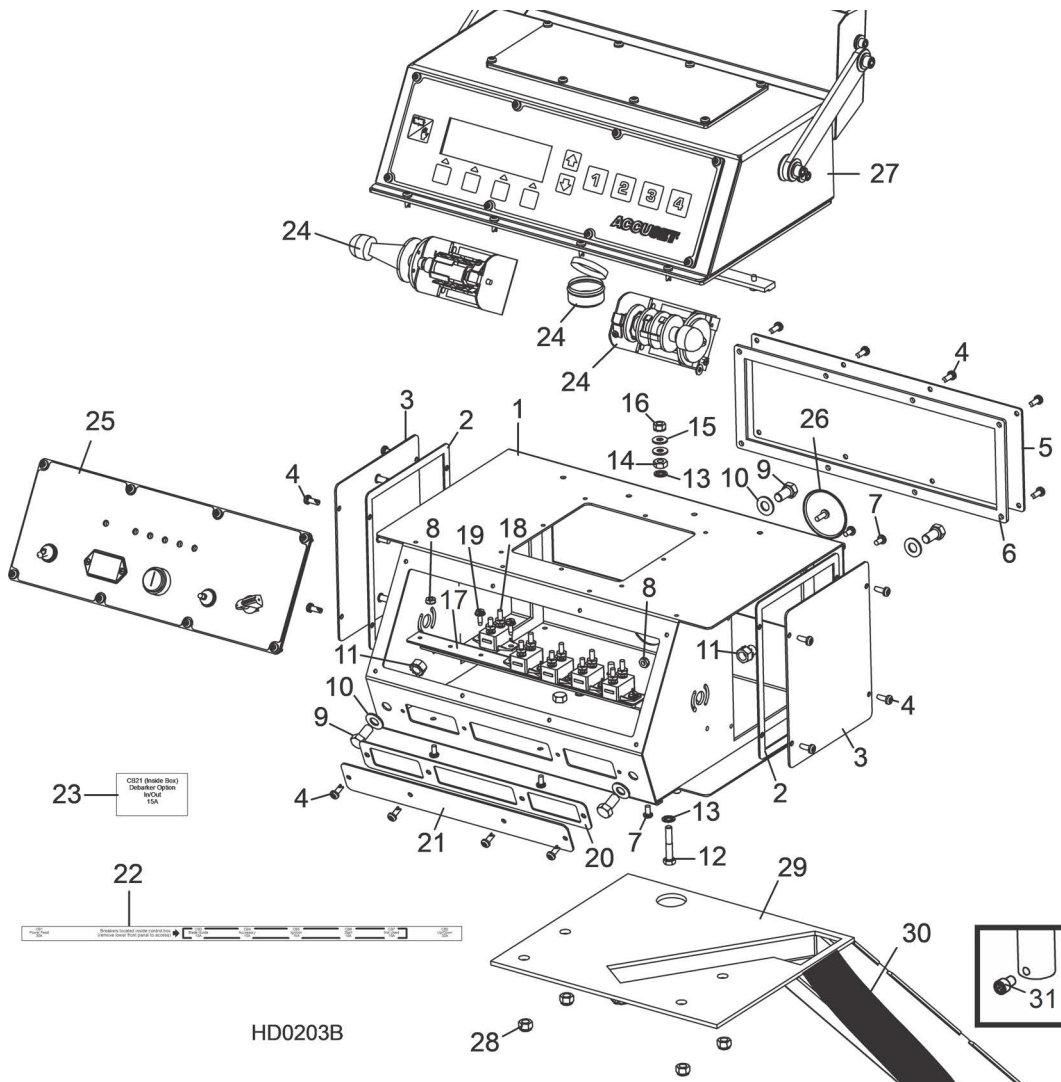

REF	PART #	DESCRIPTION	COMMENTS	QTY.
	036352	Cover, Sawmill Control Console w/Accuset		1
	053056	Control Box Assembly, G38 Remote w/Accuset 2		1
	053063	Control Box Assembly, EC25/G26 Remote w/Accuset 2		1
	053056	Control Box Assembly, D35 Remote w/Accuset 2 (International Only)		1
1	016135	Box Weldment, Control	Available in assemblies only.	1
2	015274	Gasket, Side Panel Control 97		2
3	015307	Panel Weldment, Side		2
4	F05015-17	Screw, #10-24 x 1/2" Pan Head		20
5	016230	Panel, Rear Mill Control 97		1
6	015278	Gasket, Rear Panel 97		1
7	F05004-3	Screw, 10-24 x 3/8" Phillips Pan Head Machine		5
8	F05010-14	Nut, #10-24 Self Locking		5
9	F05007-27	Bolt, 3/8-16 x 3/4" Hex Head		4

## 5 Control & Battery Boxes

Control Assembly (Accuset)

REF	PART #	DESCRIPTION	COMMENTS	QTY.
10	F05011-3	Washer, 3/8" Flat		4
11	F05010-19	Nut, 3/8-16 Self Locking		4
12	F05005-31	Bolt, 1/4-20 x 1 1/2" Hex Head Tap		1
13	F05011-69	Washer, 1/4" Heavy-Duty Interior Star Lock		2
14	F05010-129	Nut, 1/4-20 Heavy-Duty Hex Jam		1
15	F05011-11	Washer, 1/4" SAE Flat		2
16	F05010-9	Nut, 1/4-20 Hex Self-Locking		1
	015621	Breaker Assembly, Remote Control Front		1
17	052826	Rail, Circuit Breaker Self Tap		1
18	E20430	Breaker, 15Amp Auto Reset		5
19	F05015-7	Bolt, #10-24x1/2 Self Tap		6
20	015266	Gasket, Circuit Breaker Cover		1
21	015376	Panel, Circuit Breaker Cover		1
22	024658	Decal, Circuit Breaker Remote Control		1
23	024364	Decal, Circuit Breaker Debarker In/Out		1
24	N/A	Drum Switch Parts ()	<a href="#">(See Section 5.5)</a>	1
25	N/A	Control Panel Parts ()	<a href="#">(See Section 5.4)</a>	1
26	015673	Plug, AS125 Oil Tight Painted		1
27	N/A	Accuset Parts	<a href="#">(See Accuset 2 Manual)</a>	1
28	F05010-58	Nut, 5/16-18 Nylon Hex		4
29	016192	Pedestal Weldment, Remote		1
30	053054	Harness Assembly, Remote		1
	N/A	Connector Parts ()	<a href="#">(See Section 5.8)</a>	1
31	F05006-39	Screw, 5/16-18 X 1/2" Socket Head Cap Black Oxide		1

## 5.2 Control Box (SimpleSet)

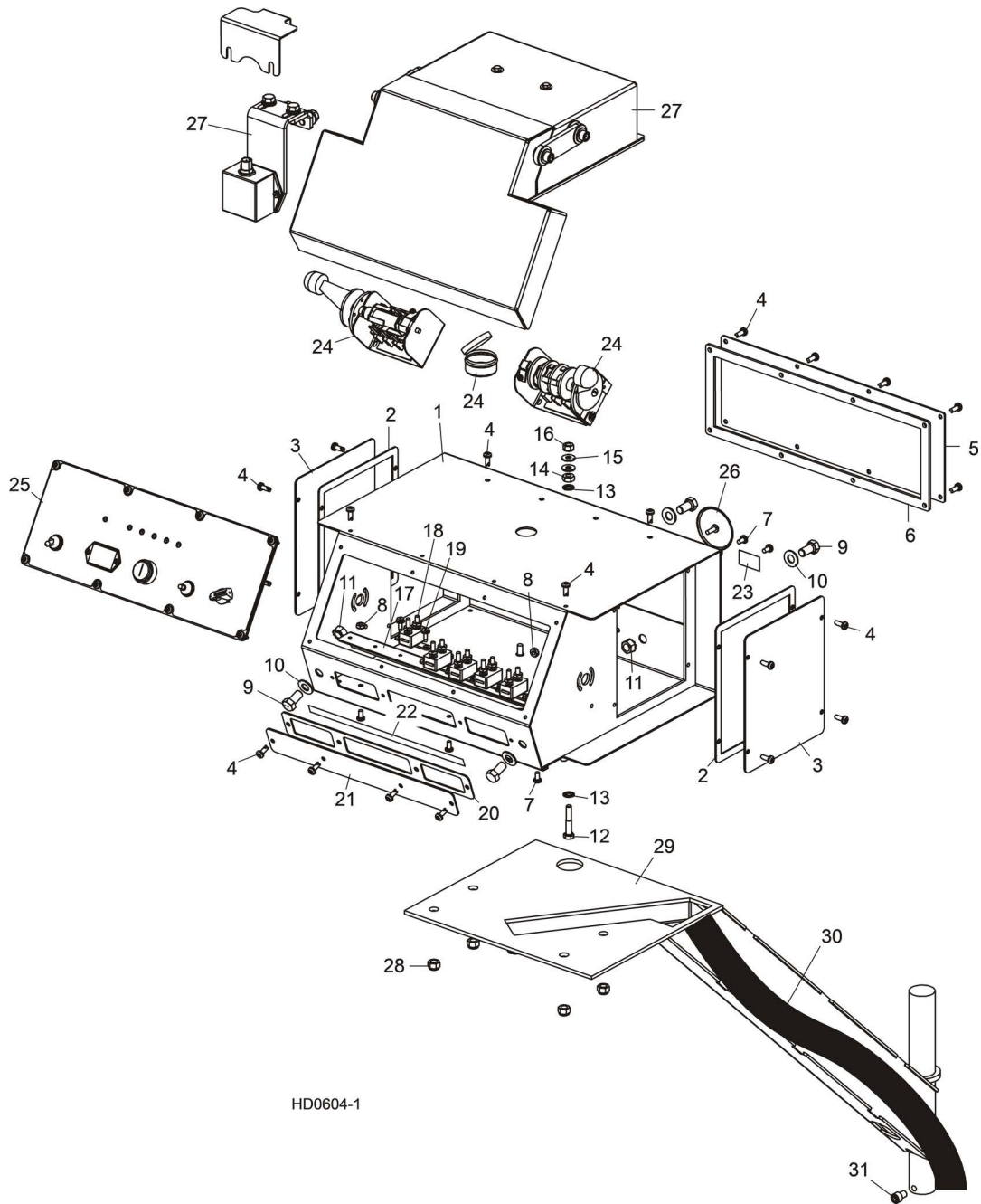

HD0604-1

REF	PART #	DESCRIPTION	COMMENTS	QTY.
	036352	Cover, Sawmill Control Console		1
	053674	Control Box Assembly, G38 Remote w/Simple Set		1
	053677	Control Box Assembly, G26 Remote w/Simple Set		1
	053674	Control Box Assembly, D35 Remote w/Simple Set (International Only)		1
1	016135	Box Weldment, Control	Available in assemblies only.	1
2	015274	Gasket, Side Panel Control 97		2
3	006473	Panel Weldment, Side		2
4	F05015-17	Screw, #10-24 x 1/2" Pan Head		24
5	016230	Panel, Rear Mill Control 97		1

# 5 Control & Battery Boxes

Control Box (SimpleSet)

REF	PART #	DESCRIPTION	COMMENTS	QTY.
6	015278	Gasket, Rear Panel 97		1
7	F05004-3	Screw, 10-24 x 3/8" Phillips Pan Head Machine		5
8	F05010-14	Nut, #10-24 Self Locking		5
9	F05007-27	Bolt, 3/8-16 x 3/4" Hex Head		4
10	F05011-3	Washer, 3/8" Flat		4
11	F05010-19	Nut, 3/8-16 Self Locking		4
12	F05005-31	Bolt, 1/4-20 x 1 1/2" Hex Head Tap		1
13	F05011-69	Washer, 1/4" Heavy-Duty Interior Star Lock		2
14	F05010-129	Nut, 1/4-20 Heavy-Duty Hex Jam		1
15	F05011-11	Washer, 1/4" SAE Flat		2
16	F05010-9	Nut, 1/4-20 Hex Self-Locking		1
	015621	Breaker Assembly, Remote Control Front		1
17	052826	Rail, Circuit Breaker		1
18	E20430	Breaker, 15Amp Auto Reset		5
19	F05015-7	Screw, #8-32 x 1/2" Slotted Head		6
20	015266	Gasket, Circuit Breaker Cover		1
21	015376	Panel, Circuit Breaker Cover		1
22	024658	Decal, Circuit Breaker Remote Control		1
23	024364	Decal, Circuit Breaker Debarker In/Out		1
24	N/A	Drum Switch Parts	<a href="#">(See Section 5.5)</a>	1
25	N/A	Control Panel Parts	<a href="#">(See Section 5.4)</a>	1
26	015673	Plug, AS125 Oil Tight Painted		1
27	N/A	SimpleSet Parts	<a href="#">()See Simple Set Manual</a>	1
28	F05010-58	Nut, 5/16-18 Nylon Hex		4
29	016192	Pedestal Weldment, Remote		1
30	053054	Harness Assembly, Remote		1
	N/A	Connector Parts ()	<a href="#">(See Section 5.8)</a>	1
31	F05006-39	Screw, 5/16-18 X 1/2" Socket Head Cap Black Oxide		1



### 5.3 Control Assembly (D35 - US Only) (Accuset)

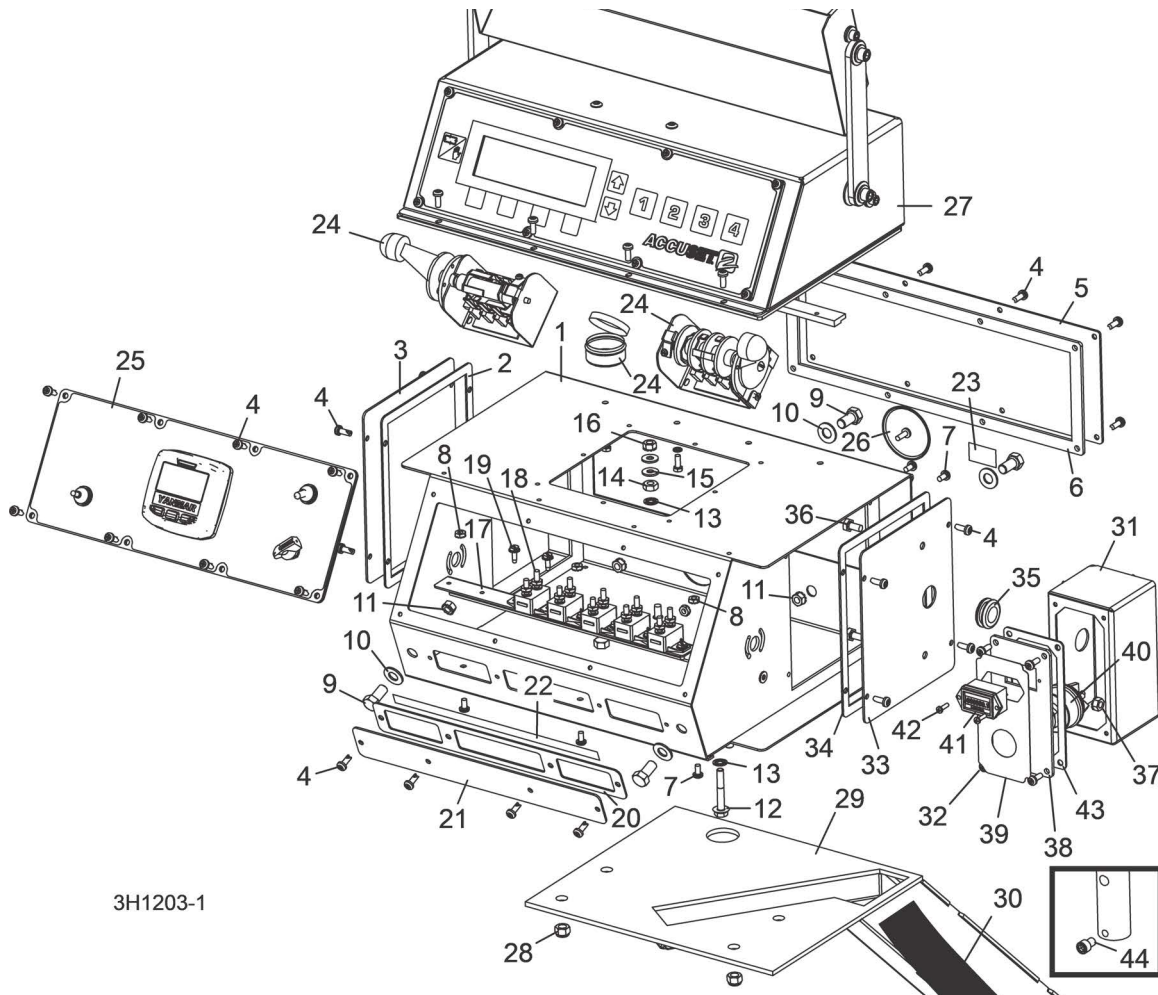

3H1203-1

REF	PART #	DESCRIPTION	COMMENTS	QTY.
	036352	Cover, Sawmill Control Console w/Accuset		1
	073621	Control Box Assembly, D35 <u>US ONLY</u> Remote w/Accuset 2		1
1	016135	Box Weldment, Control	Available in assemblies only.	1
2	015274	Gasket, Side Panel Control 97		2
3	015307	Panel Weldment, Side		2
4	F05015-17	Screw, #10-24 x 1/2" Pan Head		20
5	016230	Panel, Rear Mill Control 97		1
6	015278	Gasket, Rear Panel 97		1
7	F05004-3	Screw, 10-24 x 3/8" Phillips Pan Head Machine		5
8	F05010-14	Nut, #10-24 Self Locking		5
9	F05007-27	Bolt, 3/8-16 x 3/4" Hex Head		4
10	F05011-3	Washer, 3/8" Flat		4
11	F05010-19	Nut, 3/8-16 Self Locking		4
12	F05005-181	Screw, 1/4-20x1 3/4 Zinc Pl Flange Cap		1
13	F05011-69	Washer, 1/4" Heavy-Duty Interior Star Lock		2
14	F05010-129	Nut, 1/4-20 Heavy-Duty Hex Jam		1
15	F05011-11	Washer, 1/4" SAE Flat		2
16	F05010-9	Nut, 1/4-20 Hex Self-Locking		1
	015621	Breaker Assembly, Remote Control Front		1

**5** Control & Battery Boxes  
Control Assembly (D35 - US Only) (Accuset)

REF	PART #	DESCRIPTION	COMMENTS	QTY.
17	052826	Rail, Circuit Breaker Self Tap		1
18	E20430	Breaker, 15Amp Auto Reset		5
19	F05015-7	Bolt, #10-24x1/2 Self Tap		6
20	015266	Gasket, Circuit Breaker Cover		1
21	015376	Panel, Circuit Breaker Cover		1
22	024658	Decal, Circuit Breaker Remote Control		1
23	024364	Decal, Circuit Breaker Debarker In/Out		1
24	N/A	Drum Switch Parts ()	<a href="#">(See Section 5.5)</a>	1
25	N/A	Control Panel Parts ()	<a href="#">(See Section 5.4)</a>	1
26	015673	Plug, AS125 Oil Tight Painted		1
27	N/A	Accuset Parts	<a href="#">(See Accuset 2 Manual)</a>	1
28	F05010-58	Nut, 5/16-18 Nylon Hex		4
29	016192	Pedestal Weldment, Remote		1
30	053054	Harness Assembly, Remote		1
	N/A	Connector Parts ()	<a href="#">(See Section 5.8)</a>	1
	073603	Box Assembly, Key Switch		1
31	078426	Control Box Weldment, Key/Hour		1
32	F05015-17	Bolt, #10-24x1/2 Ph Pan Hd, Type 23		4
33	033495	Panel Weldment, Side L.H.		1
34	015274	Gasket, Side Panel Control 97		1
35	033475	Grommet, 5/8 ID 3/16 GW Rubber		1
36	F05005-15	Bolt, 1/4-20x1/2 HH		2
37	F05010-9	Nut, 1/4-20 Keps		2
	073597	Panel Assembly, Key Switch Box Frt		1
38	073598	Plate, Key Switch Box Front		1
39	073594	Decal, Key Switch		1
40	P04350	Switch, Key		1
41	015401	Digital Meter, Hour Rect Mount w/ Gasket		1
42	F05015-28	Screw, #6-32x1/2 Plain PH T23		2
43	033488	Gasket, LMS Panel		1
44	F05006-39	Screw, 5/16-18 X 1/2" Socket Head Cap Black Oxide		1

### 5.4 Control Box (SimpleSet) (D35 - US Only)

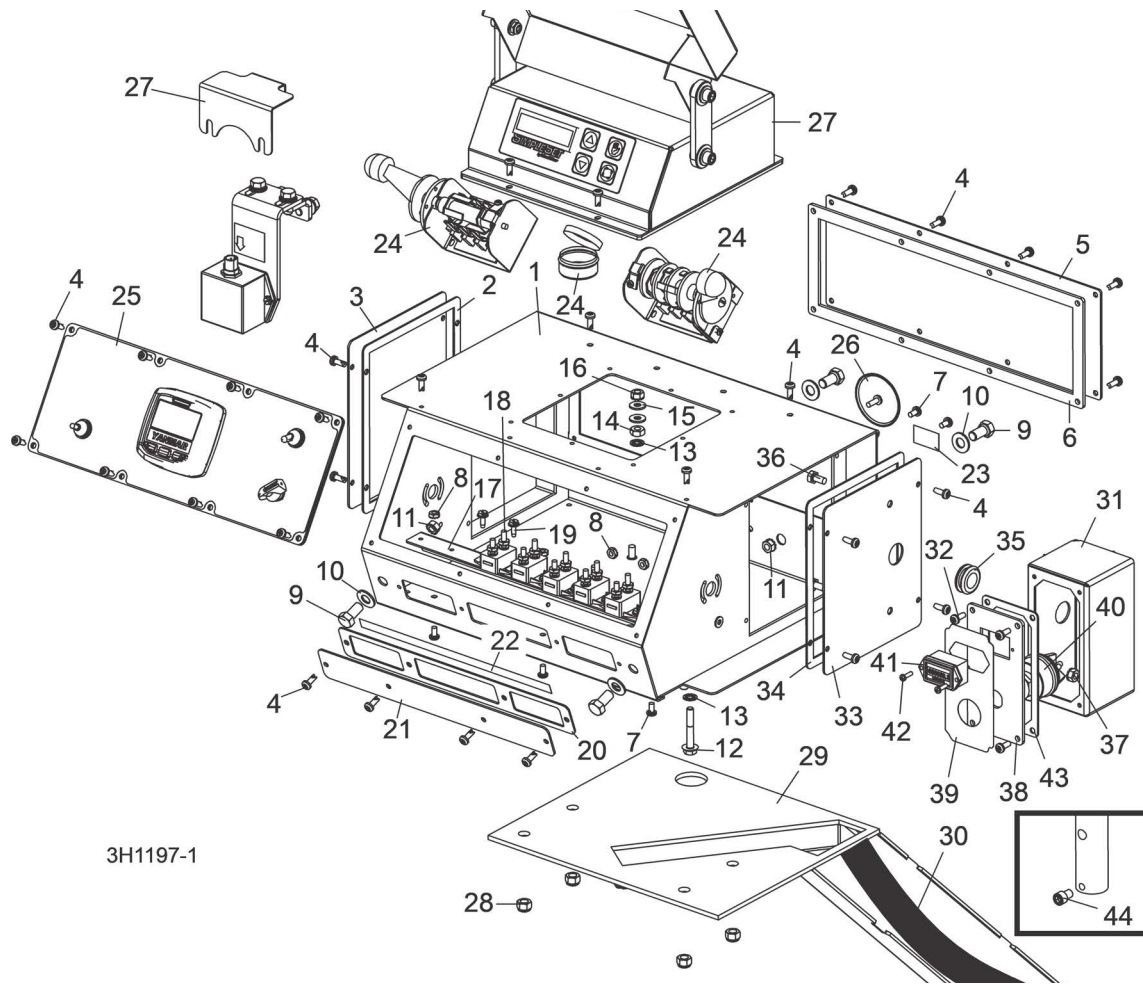

3H1197-1

REF	PART #	DESCRIPTION	COMMENTS	QTY.
	036352	Cover, Sawmill Control Console		1
	073622	Control Box Assembly, D35 <u>US ONLY</u> Remote w/Simple Set		1
1	016135	Box Weldment, Control	Available in assemblies only.	1
2	015274	Gasket, Side Panel Control 97		2
3	006473	Panel Weldment, Side		2
4	F05015-17	Screw, #10-24 x 1/2" Pan Head		24
5	016230	Panel, Rear Mill Control 97		1
6	015278	Gasket, Rear Panel 97		1
7	F05004-3	Screw, 10-24 x 3/8" Phillips Pan Head Machine		5
8	F05010-14	Nut, #10-24 Self Locking		5
9	F05007-27	Bolt, 3/8-16 x 3/4" Hex Head		4
10	F05011-3	Washer, 3/8" Flat		4
11	F05010-19	Nut, 3/8-16 Self Locking		4
12	F05005-31	Bolt, 1/4-20 x 1 1/2" Hex Head Tap		1
13	F05011-69	Washer, 1/4" Heavy-Duty Interior Star Lock		2
14	F05010-129	Nut, 1/4-20 Heavy-Duty Hex Jam		1
15	F05011-11	Washer, 1/4" SAE Flat		2
16	F05010-9	Nut, 1/4-20 Hex Self-Locking		1

**5** Control & Battery Boxes  
Control Box (SimpleSet) (D35 - US Only)

REF	PART #	DESCRIPTION	COMMENTS	QTY.
	052826	Rail, Circuit Breaker Self Tap		1
17	E20430	Breaker, 15Amp Auto Reset		5
18	F05015-7	Bolt, #10-24x1/2 Self Tap		6
19	052826	Rail, Circuit Breaker Self Tap		1
20	015266	Gasket, Circuit Breaker Cover		1
21	015376	Panel, Circuit Breaker Cover		1
22	024658	Decal, Circuit Breaker Remote Control		1
23	024364	Decal, Circuit Breaker Debarker In/Out		1
24	N/A	Drum Switch Parts ()	<a href="#">(See Section 5.5)</a>	1
25	N/A	Control Panel Parts ()	<a href="#">(See Section 5.4)</a>	1
26	015673	Plug, AS125 Oil Tight Painted		1
27	N/A	SimpleSet Parts	<a href="#">(See Simple Set Manual)</a>	1
28	F05010-58	Nut, 5/16-18 Nylon Hex		4
29	016192	Pedestal Weldment, Remote		1
30	053054	Harness Assembly, Remote		1
	N/A	Connector Parts	<a href="#">(See Section 5.8)</a>	1
	073603	Box Assembly, Key Switch		1
31	078426	Control Box Weldment, Key/Hour		1
32	F05015-17	Bolt, #10-24x1/2 Ph Pan Hd, Type 23		4
33	033495	Panel Weldment, Side L.H.		1
34	015274	Gasket, Side Panel Control 97		1
35	033475	Grommet, 5/8 ID 3/16 GW Rubber		1
36	F05005-15	Bolt, 1/4-20x1/2 HH		2
37	F05010-9	Nut, 1/4-20 Keps		2
	073597	Panel Assembly, Key Switch Box Frt		1
38	073598	Plate, Key Switch Box Front		1
39	073594	Decal, Key Switch		1
40	P04350	Switch, Key		1
41	015401	Digital Meter, Hour Rect Mount w/ Gasket		1
42	F05015-28	Screw, #6-32x1/2 Plain PH T23		2
43	033488	Gasket, LMS Panel		1
44	F05006-39	Screw, 5/16-18 X 1/2" Socket Head Cap Black Oxide		1

## 5.5 Drum Switches

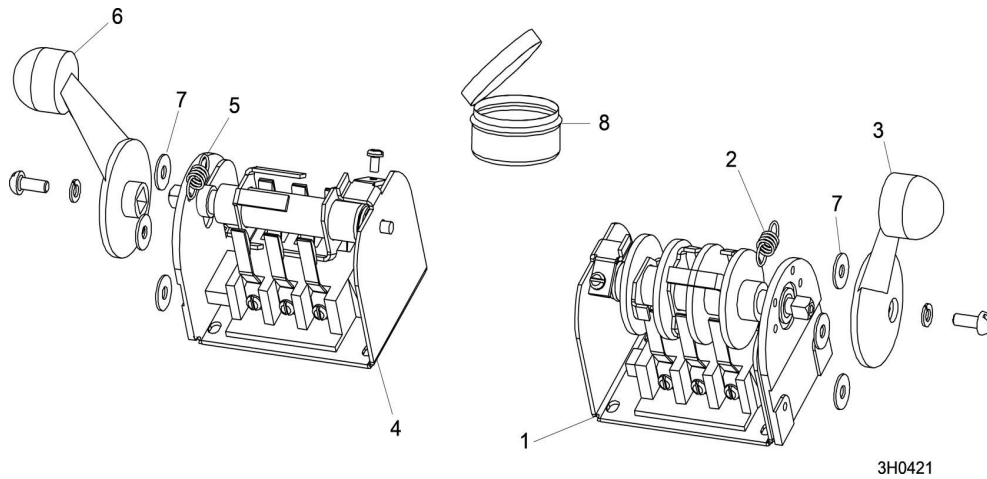

REF	PART #	DESCRIPTION	COMMENTS	QTY.
	E20440	<b>SWITCH ASSEMBLY, UP/DOWN DRUM</b>		1
1	E20440-B	Switch, S12 Bulk Drum	Available in assemblies only.	1
2	P12570	Spring, Drum Switch		1
3	P12500	Handle, Drum Switch Replacement		1
	E20439	<b>SWITCH ASSEMBLY, POWER FEED DRUM</b>		1
4	E20439-B	Switch, S11 Bulk Drum	Available in assemblies only.	1
5	P12570	Spring, Drum Switch		1
6	P12500	Handle, Drum Switch Replacement		1
7	F05011-41	<b>WASHER, #8 SAE FLAT</b>		6
8	A20463	<b>CUP ASSEMBLY, DRUM SWITCH GREASE</b>		1

## 5.6 Front Panel Assembly

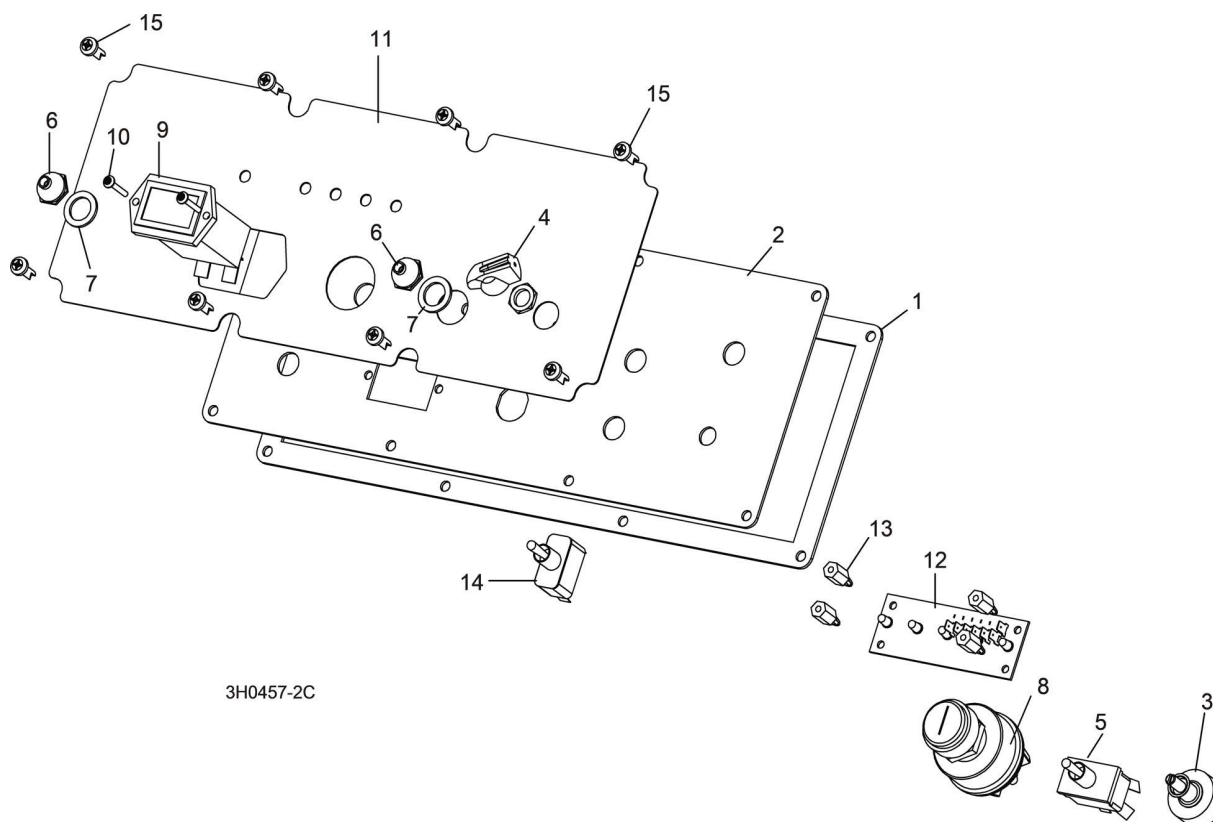

3H0457-2C

REF	PART #	DESCRIPTION	COMMENTS	QTY.
	024671	Panel Assembly, Control Front <b>D35 International</b> and G38 Remote		1
	024673	Panel Assembly, Control Front G26 Remote		1
<b>1</b>	015270	Gasket, Front Panel		1
<b>2</b>	015302	Panel Weldment, Control		1
<b>3</b>	024450-1	Switch Assembly, Feed Rate		1
<b>4</b>	P06257	Knob, Feed Rate With Set Screw		1
<b>5</b>	024200	Switch, Toggle		1
<b>6</b>	P02575	Boot, Toggle Switch Rubber		2
<b>7</b>	P05251-1	Washer, 1/2 x 3/4 x 1/16" Nylon		2
<b>8</b>	P04350	Switch, Key		1
<b>9</b>	015401	Meter, Hour		1
<b>10</b>	F05015-28	Screw, #6-32 x 1/2" Plain PH T23		2
<b>11</b>	015271	Decal, Control Panel (G28)		1
	015269	Decal, Control Panel (D35/G38)		1
<b>12</b>	015416	Board, LED Circuit (G28)		1
	015409	Board, LED Circuit (D35/G38)		1
<b>13</b>	023147	Spacer, 1/2"-#6 Threaded		4
<b>14</b>	051346	Switch, On/On Toggle SPDT		1
<b>15</b>	F05015-17	Screw, #10-24 x 1/2" Pan Head		8
	050399	Conduit, 1 1/4" x 58" Flex		1
	024402	Connector, 1 1/4" Straight Male Metal Conduit		1
	R02374	Conduit, 1/2" Expandable Black		41 in.
	R02374	Conduit, 1/2" Expandable Black		42 in.

## 5.7 Front Panel Assembly & Harnesses (D35 - US Only)

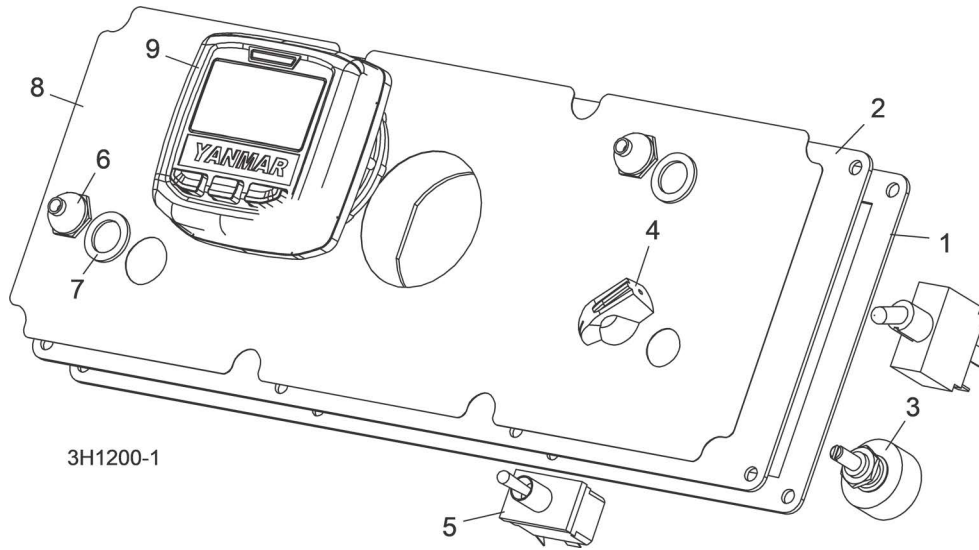

REF	PART #	DESCRIPTION	COMMENTS	QTY.
	073627	Panel Assembly, LT40 STD-R Front <b>D35 (US ONLY)</b> Remote		1
<b>1</b>	015270	Gasket, Front Panel		1
<b>2</b>	011298	Panel, LT40/50 Control Box Front		1
<b>3</b>	024450	Pot Assembly, Feed Rate Control Sawmill		1
<b>4</b>	P06257	Knob, Feed Rate With Set Screw		1
<b>5</b>	024200	Switch, Toggle		1
<b>6</b>	P02575	Boot, Toggle Switch Rubber		2
<b>7</b>	P05251-1	Washer, 1/2 x 3/4 x 1/16" Nylon		2
<b>8</b>	073593	Decal, Yanmar Tier 4 Control Panel Front		1
<b>9</b>	073601	Controller, Yanmar Tier 4 Engine		1
<b>10</b>	051346	Switch, On/On Toggle SPDT		1
	073605	Harness Assembly, Remote Control <b>US ONLY</b>		1

## 5.8 Battery Box Assembly

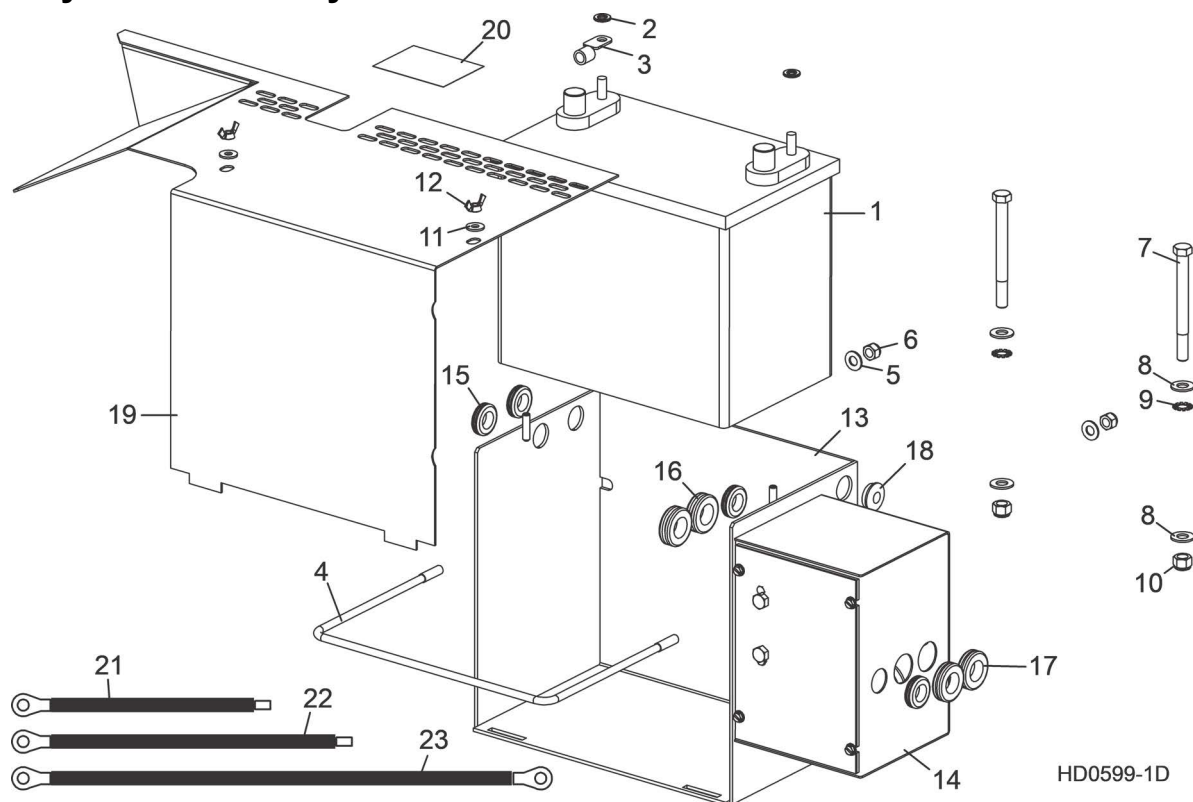

REF	PART #	DESCRIPTION	COMMENTS	QTY.
1	P12315	Battery, Deka 12V, 24M77 800CCA 1000CA	Available in assemblies only.	1
	015471	Box Assembly, LT30HD/LT40HD Battery		1
2	F05011-13	Washer, 5/16" Split Lock		2
3	F05092-16	Terminal, 5/16 1-2 Ga Ring NI Loose		1
4	P09790	Retainer Loop, Battery		1
5	F05011-17	Washer, 5/16" SAE Flat		2
6	F05010-58	Nut, 5/16-18 Hex Nylon Lock		2
7	F05007-4	Bolt, 3/8-16 X 4" Hex Head Grade 2		2
8	F05011-3	Washer, 3/8" SAE Flat		2
9	F05011-36	Washer, 3/8" External Star		2
10	F05010-10	Nut, 3/8" Hex Nylon Lock		2
11	F05011-11	Washer, 1/4" SAE Flat		2
12	F05010-13	Nut, 1/4-20 Wing		2
13	015472	Box Weldment, Battery		1
14	006795	Fuse Box Parts	<a href="#">(See Section 5.7)</a>	1
	017671	Contact Assembly, Positive Hyd Power (97+)	<a href="#">(See Section 10.3)</a> Not shown	1
15	P11764	Grommet, 5/8" Rubber Wire		4
16	074198	Grommet, 3/4" ID 11 Gauge Thickness		2
17	074199	Grommet, 3/4" ID 16 Gauge Thickness		2
18	052496	Plug, 1/2" Knockout Nylon		1
19	015774	Lid Weldment, Battery Box Standard		1
20	014774	Decal, Battery Box Lid Caution		1
21	036308	Cable Assembly, 1AWG Red x12 (1x5/16 Term)	Fuse To Battery Positive	1
22	036309	Cable Assembly, 1AWG Red x16 (1x5/16 Term)	Fuse To Battery Positive	1
23	036306	Cable Assembly, 1AWG Blk x26 (2x5/16 Term)	Battery Negative to Neg. Contact	1



## 5.9 Fuse Box Assembly

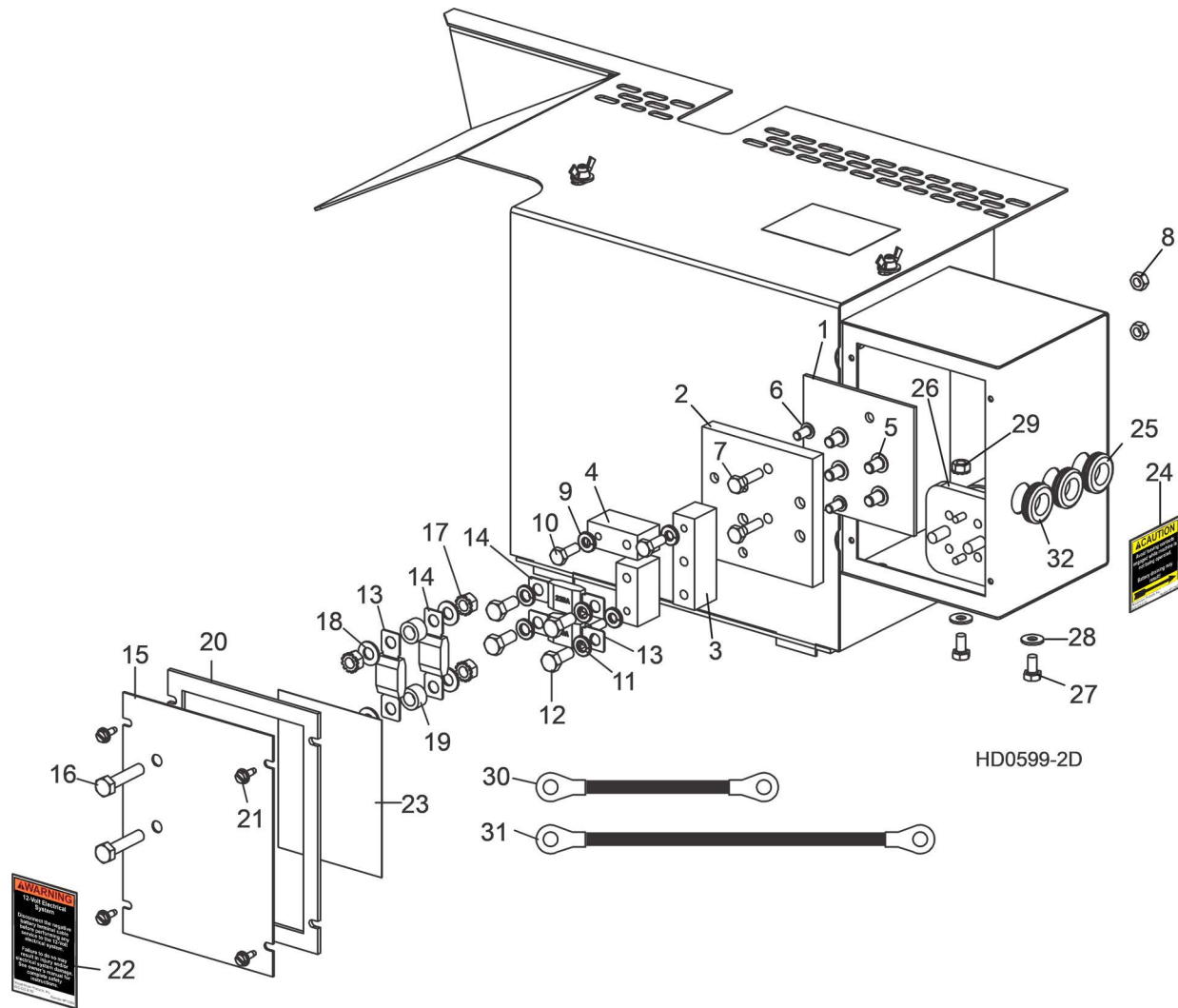

REF	PART #	DESCRIPTION	COMMENTS	QTY.
	006795	<b>BLOCK ASSEMBLY, DOUBLE FUSE</b>		1
1	056999	Plate, Fuse Block Insulator		1
2	056997	Block, Fuse Mount	Available in assemblies only.	1
3	056996	Block, 3/4" Upper Fuse		1
4	056998	Block, 3/4" Lower Fuse		2
5	F05006-20	Screw, 5/16-18 x 1/2" Socket Button Head		4
6	F05005-59	Screw, 1/4-20 x 1/2" Socket Button Head		2
7	F05005-101	Bolt, 1/4-20 x 1" Hex Head Grade 5		2
8	F05010-21	Nut, 1/4-20 Hex Lock		2
9	F05011-14	Washer, 1/4" Split Lock		3
10	F05005-123	Bolt, 1/4-20 x 3/4" Hex Head Grade 5		3
11	F05011-13	Washer, 5/16" Split Lock		4
12	F05006-102	Bolt, 5/16-18 x 3/4" Hex Head Grade 5		4
13	052370-150	Fuse, 150A Mega		2
14	053339	Fuse, 225A 32V Mega		2
	006853	Cover Assembly, Double Fuse Box		1
15	006851	Cover, Fuse Box		1

# 5 Control & Battery Boxes

Fuse Box Assembly

REF	PART #	DESCRIPTION	COMMENTS	QTY.
16	F05006-2	Bolt, 5/16-18 x 1 1/2" Hex Head Full Thread		2
17	F05010-20	Nut, 5/16-18 Hex Self-Locking		4
18	F05011-17	Washer, 5/16" SAE Flat		4
19	055323	Spacer, .39" x .625" x .39"		2
20	050283	Gasket, Fuse Box Cover		1
21	F05015-7	Screw, #10-24 X 1/2" Self-Tapping		4
22	P10364	Decal, 12 Volt Warning		1
23	006867	Decal, 150/225A mega Fuse ID		1
24	P12960	Decal, Hydraulic Contact Caution		1
25	074199	Grommet, 3/4" ID 16 Gauge Thickness		2
26	016371	Solenoid Kit, 200A 12V SPST Cont. Duty		1
	015470	Solenoid, 200A 12V SPST Cont. Duty	Available in assemblies only.	1
	015426	Diode Assembly, Solenoid Coil Chassis Gnd		1
	024451	Wire Assembly, Hydraulic Solenoid Voltage Drop		1
27	F05005-15	Bolt, 1/4-20 x 1/2" Hex Head		2
28	F05011-11	Washer, 1/4" SAE Flat		2
29	F05010-9	Nut, 1/4-20 Self-Locking Hex		2
30	036305	Cable Assembly, 1 Ga x 6 1/2" Fuse To Solenoid		1
31	036307	Cable Assembly, 1 Ga x 14" Solenoid To Positive Contact		1
32	P11764	Grommet, 5/8" ID Rubber		1

### 5.10 Remote Power Box Assembly (Accuset)

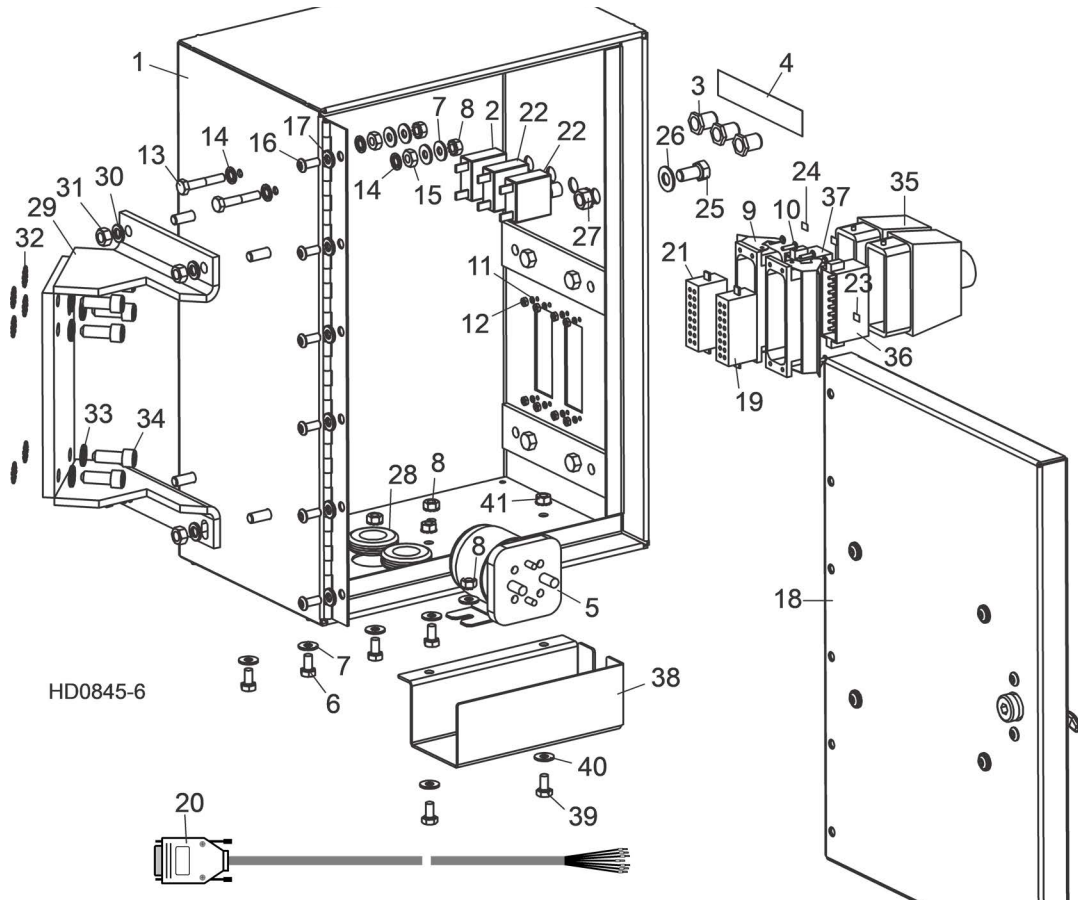

REF	PART #	DESCRIPTION	COMMENTS	QTY.
	069335	Box Assembly, D35 Remote Power w/Dual-Axis Accuset	International only	1
	069336	Box Assembly, D36 Remote Power w/Dual-Axis Accuset		1
	069432	Box Assembly, G38 Remote Power w/Dual-Axis Accuset		1
	069535	Box Assembly, G26 Remote Power W/Dual-Axis Accuset		1
1	006667	Box Weldment, Remote Power 2008		1
2	021256	Breaker, 50A Manual Reset Panel Mount		1
3	021253	Boot, Circuit Breaker		3
4	069352	Decal, Standard Remote Circuit Breaker ID 2010		1
5	016371	Solenoid Kit, 200A 12V SPST Hydraulic Motor		1
	015470	Solenoid, 200A 12V SPST Cont. Duty	Available in assemblies only.	1
	015426	Diode Assembly, Solenoid Coil Chassis Gnd		1
	051528	Resistor Assembly, 4.3Ohm 5W		1
6	F05005-15	Bolt, 1/4-20 x 1/2" Hex Head		4
7	F05011-11	Washer, 1/4" SAE Flat		10
8	F05010-9	Nut, 1/4-20 Self-Locking Hex		6
9	E23103	Connector, 16-Pin Panel Mount Single Lever		2
10	F05004-14	Screw, #4-40 x 1/2" Slotted Round Head		8
11	F05011-21	Washer, #4 Split Lock		8
12	F05010-43	Nut, #4-40 Hex		8
13	F05005-31	Bolt, 1/4-20 x 1 1/2" Hex Head Full Thread		2
14	F05011-69	Washer, 1/4" Heavy Duty Internal Star		4
15	F05010-129	Nut, 1/4-20 Heavy Duty Hex Jam		2
16	F05005-128	Bolt, 1/4-20 x 5/8" Button Socket Head		6

**5** Control & Battery Boxes  
Remote Power Box Assembly (Accuset)

REF	PART #	DESCRIPTION	COMMENTS	QTY.
17	F05011-14	Washer, 1/4" Split Lock		6
18	053228	Door Assembly	<a href="#">(See Section 5.12)</a>	1
	053231	Harness Assembly, Remote Power Box 17-32		1
19	015671	Insert, Female 10A 16P Scr. Term. 17-32		1
20	053222	Harness Assembly, Dual-Axis Motor Control Remote		1
	053230	Harness Assembly, Remote Power Box 1-16		1
21	E23106	Insert, Female 10A 16P Scr. Term. 1-16		1
22	024246	Breaker, 30A Manual Reset Panel Mount		2
23	024368	Decal, Connector ID (J1)		2
24	024369	Decal, Connector ID (J2)		2
25	F05007-27	Bolt, 3/8-16 x 3/4" Hex Head		1
26	F05011-3	Washer, 3/8" SAE Flat		1
27	F05010-19	Nut, 3/8-16 Self-Locking Hex		1
	069315	Harness Assembly, D35 Remote Upper		1
	069314	Harness Assembly, D34/D36 Remote Upper		1
	069430	Harness Assembly, G38 Remote Upper		1
	069532	Harness Assembly, G26 Remote Upper (2011)		1
	051900	Harness Assembly, D35 Remote Lower		1
	050682	Harness Assembly, D36/G38 Remote Lower		1
	050683	Harness Assembly, G28 Remote Lower		1
28	P702	Grommet, 7/8" I.D. x 1 1/4" O.D. Grooved Rubber		2
29	015184	Bracket Weldment, Remote Power Box Mounting		1
30	F05011-13	Washer, 5/16" Split Lock		4
31	F05010-17	Nut, 5/16-18 Hex		4
32	F05011-36	Washer, 3/8" Exterior Star Lock		6
33	F05011-4	Washer, 3/8" Split Lock		6
34	F05007-52	Bolt, 3/8-16 x 1" Socket Head		6
35	015658	Connector, 16-Pin Hood Single Lever Front Entry		2
36	E23105	Insert, Male 10A 16P Scr. Term. 1-16		1
37	015670	Insert, Male 10A 16P Scr. Term. 17-32		1
	006021	Guard Assembly, Lower Power Box Wire		1
38	006014	Guard, Lower Power Box Wire		1
39	F05005-15	Bolt, 1/4-20 x 1/2" Hex Head		2
40	F05011-11	Washer, 1/4" SAE Flat		2
41	F05010-9	Nut, 1/4-20 Self-Locking Hex		2

## 5.11 Remote Power Box (SimpleSet)

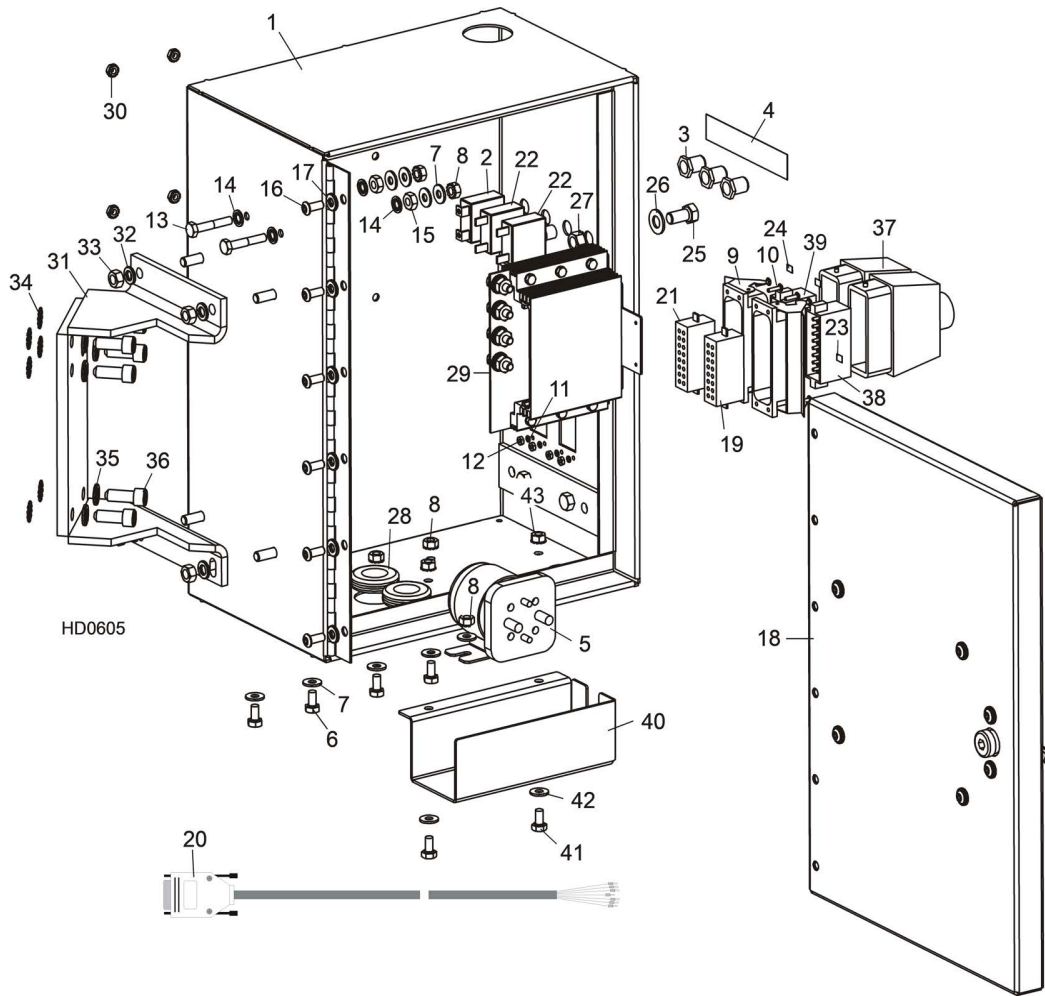

REF	PART #	DESCRIPTION	COMMENTS	QTY.
	053668	Box Assembly, D35 Remote Power w/Dual-Axis Simple set		1
	053673	Box Assembly, G38 Remote Power w/Dual-Axis Simple set		1
	069536	Box Assembly, G28 Remote Power w/Dual-Axis Simple Set (2011)		1
1	006667	Box Weldment, Remote Power 2008		1
2	021256	Breaker, 50A Manual Reset Panel Mount		1
3	021253	Boot, Circuit Breaker		3
4	069352	Decal, Standard Remote Circuit Breaker ID 2010		1
5	016371	Solenoid Kit, 200A 12V SPST Hydraulic Motor		2
	015470	Solenoid, 200A 12V SPST Cont. Duty	Available in assemblies only.	1
	015426	Diode Assembly, Solenoid Coil Chassis Gnd		1
	051528	Resistor Assembly, 4.3Ohm 5W		1
6	F05005-15	Bolt, 1/4-20 x 1/2" Hex Head		4
7	F05011-11	Washer, 1/4" SAE Flat		10
8	F05010-9	Nut, 1/4-20 Self-Locking Hex		6
9	E23103	Connector, 16-Pin Panel Mount Single Lever		2

# 5 Control & Battery Boxes

Remote Power Box (SimpleSet)

REF	PART #	DESCRIPTION	COMMENTS	QTY.
10	F05004-14	Screw, #4-40 x 1/2" Slotted Round Head		8
11	F05011-21	Washer, #4 Split Lock		8
12	F05010-43	Nut, #4-40 Hex		8
13	F05005-31	Bolt, 1/4-20 x 1 1/2" Hex Head Full Thread		2
14	F05011-69	Washer, 1/4" Heavy Duty Internal Star		4
15	F05010-129	Nut, 1/4-20 Heavy Duty Hex Jam		2
16	F05005-128	Bolt, 1/4-20 x 5/8" Button Socket Head		6
17	F05011-14	Washer, 1/4" Split Lock		6
18	053228	Door Parts	<a href="#">(See Section 5.12)</a>	1
	053231	Harness Assembly, Remote Power Box 17-32		1
19	015671	Insert, Female 10A 16P Scr. Term. 17-32		1
20	053222	Harness Assembly, Dual-Axis Motor Control Remote		1
	053230	Harness Assembly, Remote Power Box 1-16		1
21	E23106	Insert, Female 10A 16P Scr. Term. 1-16		1
22	024246	Breaker, 30A Manual Reset Panel Mount		2
23	024368	Decal, Connector ID (J1)		2
24	024369	Decal, Connector ID (J2)		2
25	F05007-27	Bolt, 3/8-16 x 3/4" Hex Head		1
26	F05011-3	Washer, 3/8" SAE Flat		1
27	F05010-19	Nut, 3/8-16 Self-Locking Hex		1
	053661	Harness Assembly, D35 Remote Upper		1
	053666	Harness Assembly, G38 Remote Upper		1
	069533	Harness Assembly, G26 Remote Upper (2011)		1
		SimpleSet Sensor Cable	<a href="#">(See Simple Set Manual)</a>	
	051900	Harness Assembly, D35/G38 Remote Lower		1
	050682	Harness Assembly, D36 Remote Lower		1
	050683	Harness Assembly, G28 Remote Lower		1
28	P702	Grommet, 7/8" I.D. x 1 1/4" O.D. Grooved Rubber		2
29	053681	SimpleSet H-Bridge Parts	<a href="#">(See Simple Set Manual)</a>	
30	F05010-14	Nut, #10-24 Keps		4
31	015184	Bracket Weldment, Remote Power Box Mounting		1
32	F05011-13	Washer, 5/16" Split Lock		4
33	F05010-17	Nut, 5/16-18 Hex		4
34	F05011-36	Washer, 3/8" Exterior Star Lock		6
35	F05011-4	Washer, 3/8" Split Lock		6
36	F05007-52	Bolt, 3/8-16 x 1" Socket Head		6
37	015658	Connector, 16-Pin Hood Single Lever Front Entry		2
38	E23105	Insert, Male 10A 16P Scr. Term. 1-16		1
39	015670	Insert, Male 10A 16P Scr. Term. 17-32		1
	006021	Guard Assembly, Lower Power Box Wire		1
40	006014	Guard, Lower Power Box Wire		1
41	F05005-15	Bolt, 1/4-20 x 1/2" Hex Head		2
42	F05011-11	Washer, 1/4" SAE Flat		2
43	F05010-9	Nut, 1/4-20 Self-Locking Hex		2

## 5.12 Remote Power Box Door Assembly

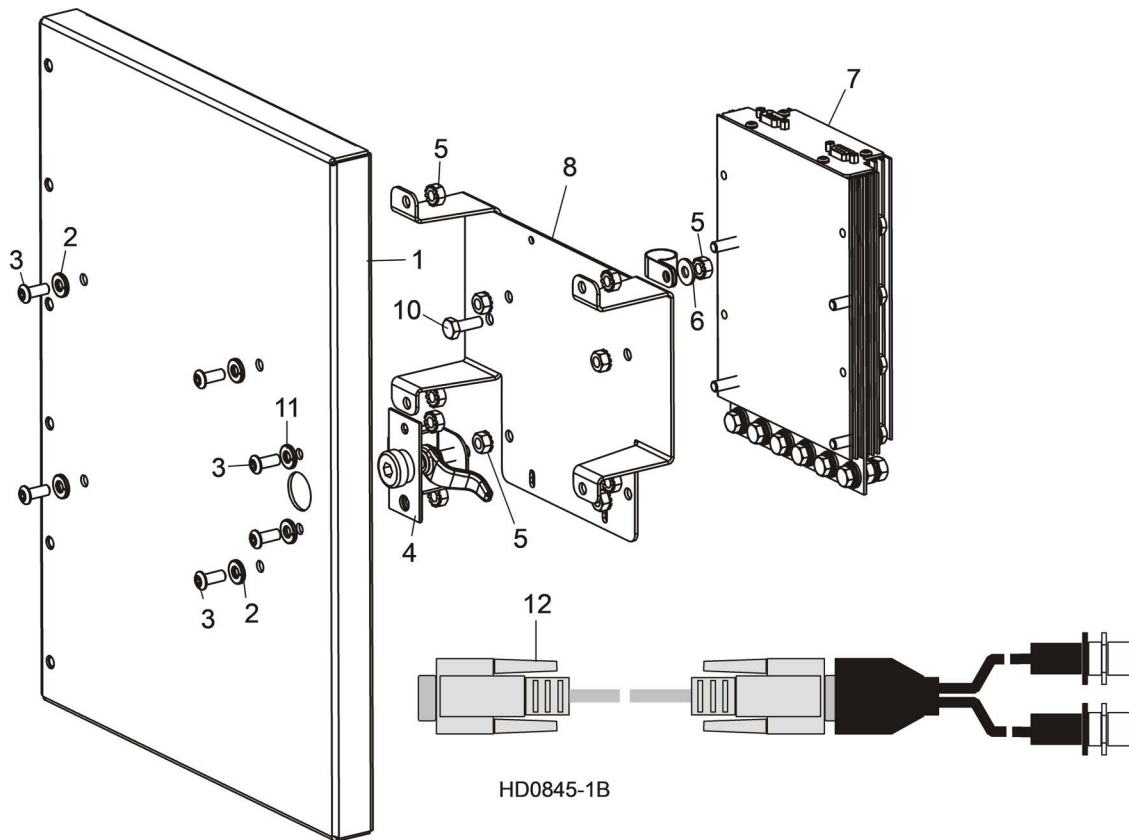

REF	PART #	DESCRIPTION	COMMENTS	QTY.
	053228	<b>DOOR ASSEMBLY, REMOTE POWER BOX W/DUAL-AXIS ACCUSET</b>		1
1	003998	Door Weldment, Remote Power Box		1
2	F05011-14	Washer, 1/4" Split Lock		4
3	F05005-128	Bolt, 1/4-20 x 5/8" Button Socket Head		6
4	P20048	Latch, Power Box Door		1
5	F05010-9	Nut, 1/4-20 Self-Locking Hex		11
6	F05011-11	Washer, 1/4" SAE Flat		1
7	057821LS	Control Assembly, Dual-Axis Motor		1
8	056763	Bracket, DCS Control Mount		1
9	010748	Clamp, 5/8" EMT Coated		1
10	F05005-1	Bolt, 1/4-20 x 3/4" Hex Head Full Thread		1
11	F05011-14	Washer, 1/4" Split Lock		2
12	053696	Cable Assembly, Dual M12 to D-Sub		1

## SECTION 6 UP/DOWN SYSTEM

### 6.1 Head Mount

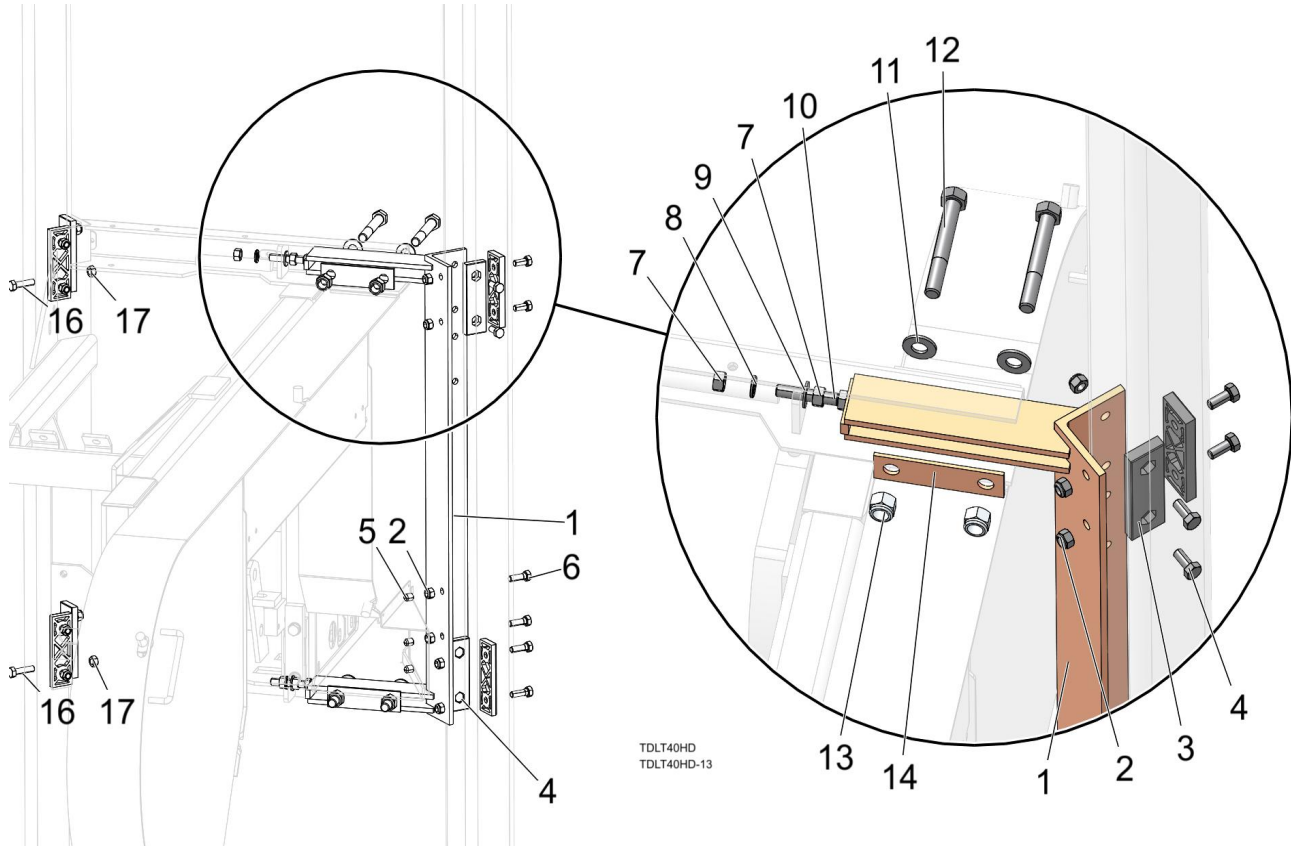

REF	PART #	DESCRIPTION	COMMENTS	QTY.
	A07540	Slide Assembly, C-Frame Back W/Delrin		1
1	W04099	Slide Weldment, Delrin Pad Back Mnt		1
2	F05010-58	Nut, 5/16-18 Nyl Lock		16
3	M04096	Pads, Delrin Up/Dn Slide		8
4	F05006-5	Bolt, 5/16-18x3/4 HH Gr2		12
5	017715	Cap, .281x3/8 In Black Vinyl		3
6	F05006-1	Bolt, 5/16-18x1 HH Gr2		4
7	F05010-1	Nut, 3/8-16 Hex		4
8	F05011-4	Washer, 3/8 Split Lock		2
9	F05011-3	Washer, 3/8 Flat SAE		2
10	F05007-16	Bolt, 3/8-16x2 HH FT		2
11	F05011-2	Washer, 1/2 SAE Flat		2
12	F05008-61	Bolt, 1/2-13x3 1/2 Hex Head GR5 Zinc		2
13	F05010-8	Nut, 1/2-13 Nyl Hex Lock		4
14	S07935	Plate, .125x1.13x4.13 Washer		2
15	A07540	Slide Assembly, C-Frame Back W/Delrin		1
16	F05006-93	Bolt, 5/16-18x1-1/4 HH FT Gr5		2
17	F05010-17	Nut, 5/16-18 Hex		2



## 6.2 Blade Height & Quarter Scales

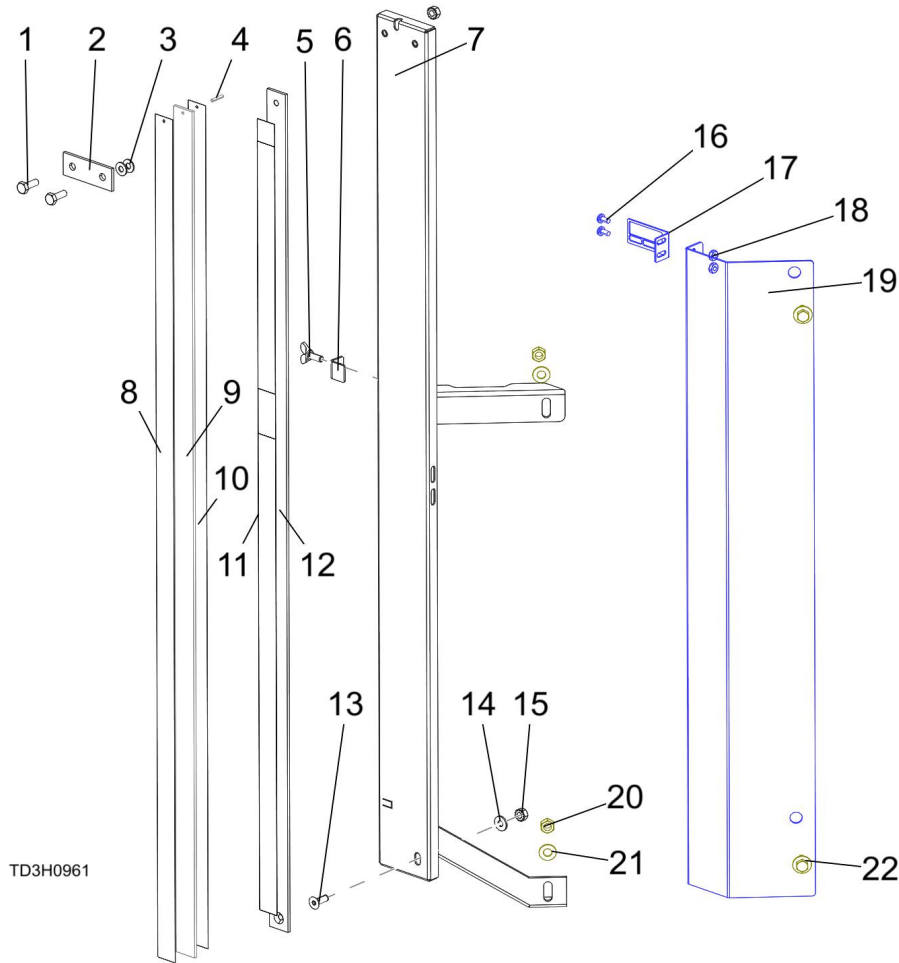

REF	PART #	DESCRIPTION	COMMENTS	QTY.
	A12022	Scale Assembly, Sawhead	Order K11998 for replacement kit	
1	F05005-1	Bolt, 1/4-20x3/4 FT HHC		2
2	S04805	Plate, 1/8x1x2 5/8 Al Scale		1
3	F05011-22	Washer, 1/4 .020 Thick Nylon		2
4	F05012-14	Pin, 1/8x5/8 Roll Zinc		1
5	F05005-64	Stud, 1/4-20x5/8 Wing		1
6	036666	Plate, Movable Scale Stop		1
7	W11997	Mount Wdmt, Scale Ptd		1
	S11989	Scale Assembly, Standard Quarter		1
8	S11774	Decal, Moveable Quarter Scale		1
9	R01665	Flat, 1/8x1x37- 5/8 6063 T6 AL		1
10	P12819	Decal, 37 1/2 Grade Quarter		1
11	S11773	Decal, Moveable Inch Scale		1
12	S11988	Plate, 1/8x1x37 1/4 Alum Inch		1
13	F05005-70	Bolt, 1/4-20x3/4 FHS		1
14	F05011-11	Washer, 1/4 SAE Flat		1
15	F05010-9	Nut, 1/4-20 Keps		2
	038591	Pointer Assembly, Adjustable Scale		1

**6** **Up/Down System**  
Blade Height & Quarter Scales

REF	PART #	DESCRIPTION	COMMENTS	QTY.
16	F05004-3	Bolt, #10-24x3/8 CrSI PH		2
17	038585	Pointer, Bent Scale Height		1
18	F05010-14	Nut, #10-24 Keps		2
19	038586	Plate, Bent Pointer Mount		1
20	F05010-6	Nut, 5/16-18 Swaged Hex		2
21	F05011-17	Washer, 5/16 SAE Flat		2
22	F05005-134	Bolt, 1/4-20x3/4 W/Conical Washer		2
	K12064	<b>DECAL KIT, METRIC SCALE</b>	Optional	1
	S11711	Decal, Metric		1
	P12040-1	Scale Assembly, Metric Quarter		1
	R01665	Flat, 1/8x1x192 6063 T6 Al		
	F05012-14	Pin, 1/8x5/8 Roll Zinc		
	P12040-1	Decal, 16-40CM Metric		
	P12040-2	Decal, 45-63CM Metric		

### 6.3 Up/Down Chain & Sprockets

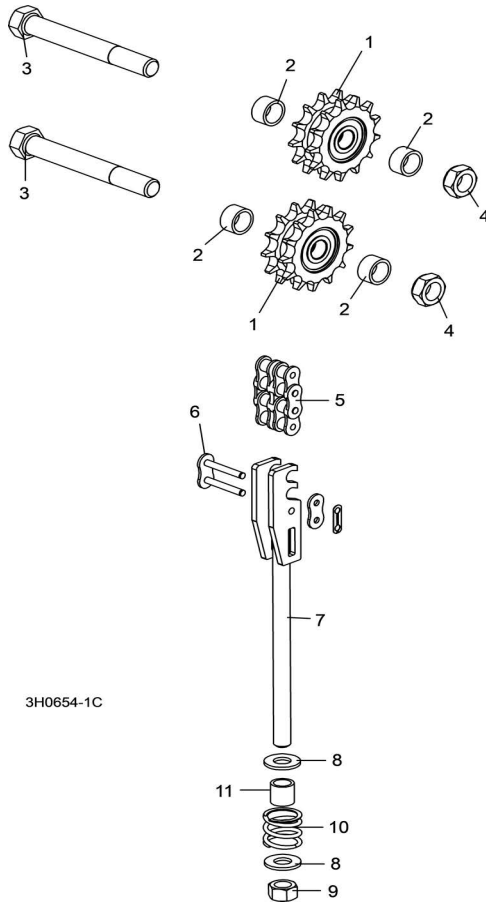

REF	PART #	DESCRIPTION	COMMENTS	QTY.
	016020	Sprocket Kit, Up/Down Idler #50-2		1
1	016019	Sprocket, Up/Down Idler '98		2
2	016018	Spacer, 50-2 Idler '98		4
	016020-541	Instruction Sheet, Up/Down Idler Retrofit		1
3	F05009-6	Bolt, 5/8-11 X 5" Hex Head Grade 2		2
4	F05010-96	Nut, 5/8-11 Jam Nylon Lock		2
5	015259	Chain, #50-2 X 75.625" Up/Down		1
6	015258	Link, #50-2 Master		2
	015456	Tensioner Assembly, Up/Down Chain		1
7	015188	Bracket, Up/Down #50 Chain Tensioner	Available in assemblies only.	1
8	F05011-2	Washer, 1/2" SAE Flat		2
9	F05010-8	Nut, 1/2-13 Hex Nylon Lock		1
10	016516	Spring, 1" OD x 1" Long x .125" Wire Compr.		1
11	016515	Spacer, Up/Dn Chain Tensioner		1

## 6.4 Up/Down Assembly

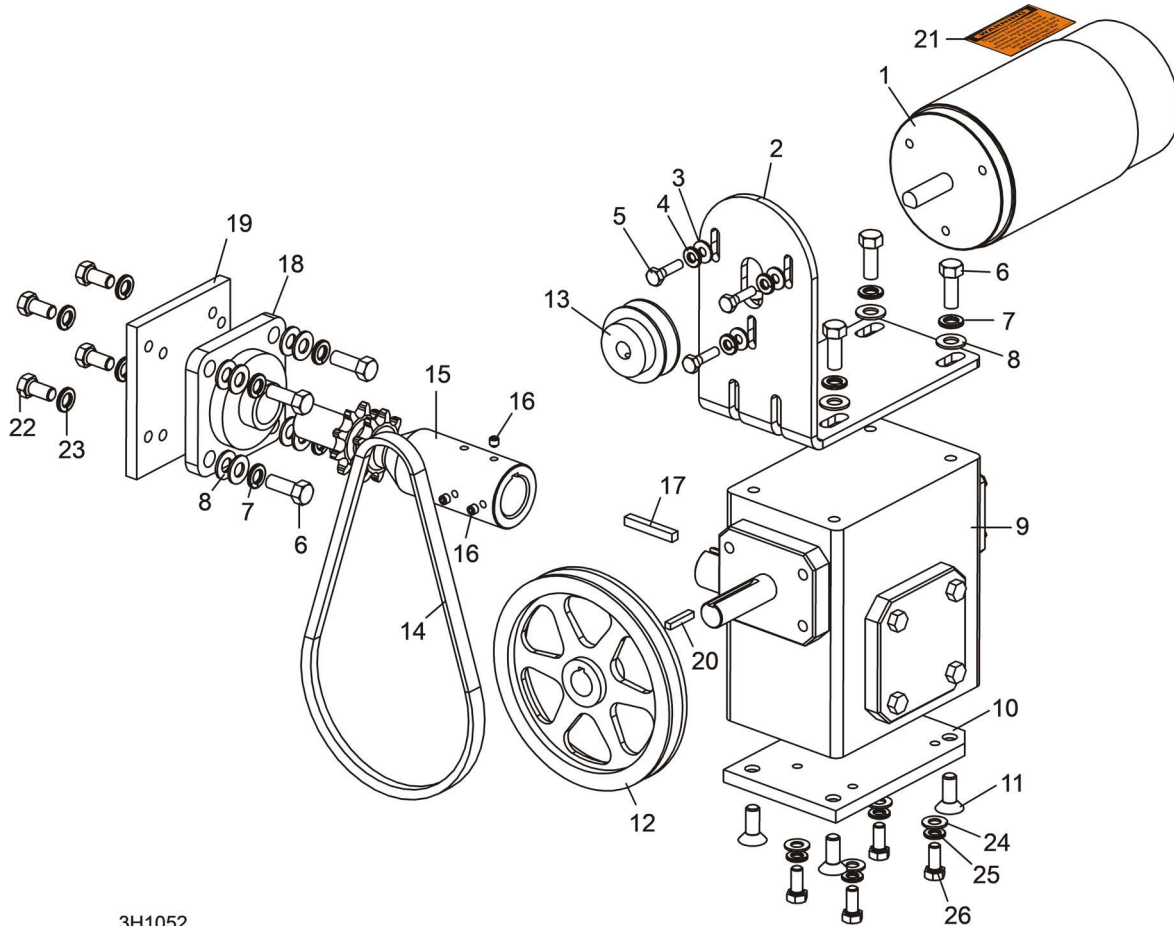

3H1052

REF	PART #	DESCRIPTION	COMMENTS	QTY.
	008722	<b>UP/DOWN DRIVE ASSEMBLY</b>		1
<b>1</b>	053683	Motor, 3/4HP 12VDC Electric		1
	061794	Brush Kit, .5-.75 12V DC Motor		1
<b>2</b>	008721	Bracket, Up/Down Motor Mount		1
	3	F05011-11	Washer, 1/4" SAE Flat	3
	4	F05011-14	Washer, 1/4" Split Lock	3
	5	F05005-101	Bolt, 1/4-20 X 1" Hex Head Grade 5	3
	6	F05007-7	Bolt, 3/8-16 x 1" Hex Head	8
	7	F05011-4	Washer, 3/8" Split Lock	8
	8	F05011-3	Washer, 3/8" SAE Flat	12
	9	074124	Gear Box, Up/Down Grove	1
	10	014158	Plate, Gear Box Spacer	1
	11	F05007-64	Bolt, 3/8-16 x 1" Flat Socket Head	4
	12	014088	Pulley, Up/Down	1
	036213	Belt/Pulley Kit, Standard Up/Down		1
	13	036204	Pulley, AK22 x 1/2"	1
	14	014089	Belt, 4L270	1
	016094	Shaft Kit, Up/Down Super		1
	15	016031	Shaft, Up/Down Sprocket	1
	16	F05005-105	Screw, 1/4-28 x 1/4" Socket Head Cup Point	3
	17	S04124	Key, 1/4" Square x 1 11/16" Long	1

REF	PART #	DESCRIPTION	COMMENTS	QTY.
18	014090	Bearing, Flanged Up/Down		1
19	014108	Plate, Bearing Spacer		1
20	S31027	Key, 3/16" Square x 1" Long		1
21	024431	Decal, Disconnect Motor Leads Warning		1
22	F05007-27	Bolt, 3/8-16 x 3/4" Hex Head		4
23	F05011-4	Washer, 3/8" Split Lock		4
24	F05011-17	Washer, 5/16" SAE Flat		4
25	F05011-13	Washer, 5/16" Split Lock		4
26	F05006-102	Bolt, 5/16-18 X 3/4" Hex Head Grade 5		4
	L04869-4	Oil, 8 Oz. Mobil SHC634 Bottled Synthetic Gear	24 oz. required for complete oil replacement.	1

## SECTION 7 POWER FEED SYSTEM

### 7.1 Upper Track Rollers And Wipers

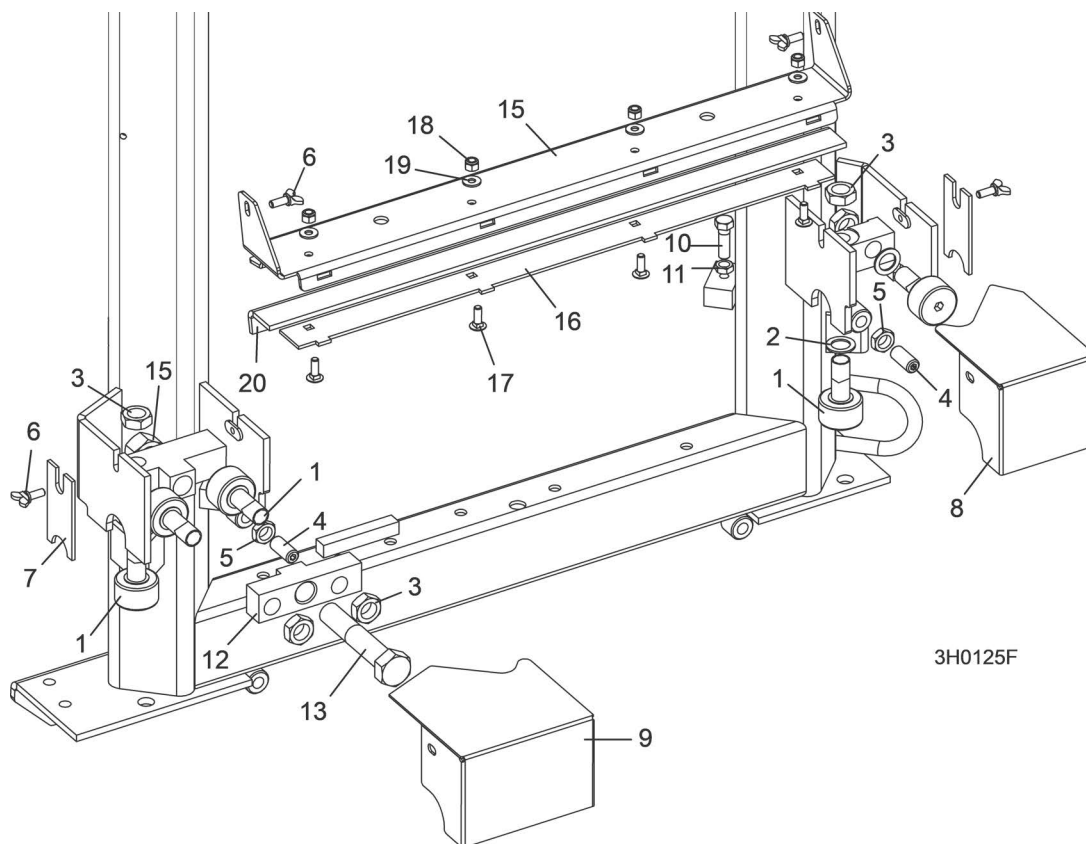

REF	PART #	DESCRIPTION	COMMENTS	QTY.
1	012797	Roller, Track Cam Bearing		5
2	016510	Shim, 5/8" x 1" x .062"		2
3	F05010-11	Nut, 5/8-18 Hex Jam		5
4	F05008-5	Screw, 1/2-13 x 1 1/4" Oval Point Set		2
5	F05010-31	Nut, 1/2-13 Hex Jam		2
6	F05005-64	Screw, 1/4-20 x 5/8" Thumb		4
7	M04113	Wiper, Plastic Track		2
8	012999	Housing, Upper Track Roller Rear		1
9	016285	Housing, Upper Track Roller Front		1
10	F05007-2	Bolt, 3/8-16 x 1 1/4" Hex Head		2
11	F05010-29	Nut, 3/8-16 Hex Jam		2
12	016501	Block, Upper Roller Pivot		1
13	F05013-3	Bolt, 3/4-10 x 4" Hex Head Grade 5		1
14	F05010-80	Nut, 3/4-10 Self Locking		1
	110612	Cover Assembly, LT40 Track		1
15	110609	Cover, Middle Track, LT40	Available in assemblies only.	1
16	110611	Retainer, Felt Oiler	Available in assemblies only.	1
17	F05005-113	Bolt, 1/4-20x3/4 Carriage		4
18	F05010-69	Nut, 1/4-20 Nylock		4
19	F05011-11	Washer, 1/4 SAE Flat		4
20	S09915	Felt, Middle Track Oiler LT40/50/70		1

## 7.2 Power Feed Assembly

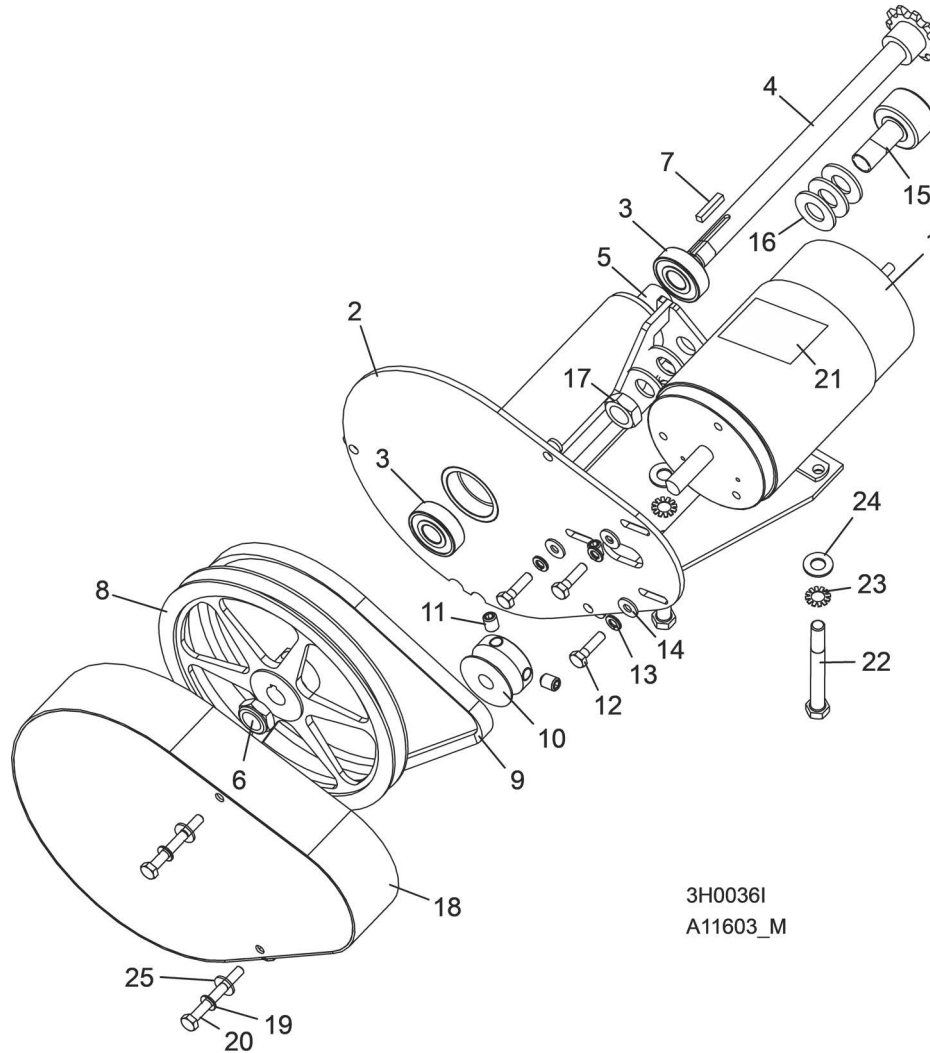

3H0036I  
A11603\_M

REF	PART #	DESCRIPTION	COMMENTS	QTY.
	A11603	<b>POWER FEED ASSEMBLY</b>		1
1	006747	Motor, Power Feed		1
	061794	Brush Kit, 12V Motor (2008)		1
	F05006-40	Screw, 5/16-18 x 3/8" Socket Head Set Oval Point		2
2	066991	Mount Weldment, LT35 Power Feed		1
3	P06030-1	Bearing, 5/8" 6203-2NSL		2
	079800	Shaft Upgrade, Power Feed		1
4	079798	Shaft Weldment, Power Feed, Threaded	Available in assemblies only.	1
5	079799	Spacer, Bearing, Power Feed		1
6	F05010-101	Nut, 5/8-18 Nyl Jam		1
7	S31027	Key, 3/16" Square x 1" Long		1
8	P04343	Pulley, 8" Power Feed		1
9	P04031	Belt, 4L280 V		1
10	S09579	Pulley, Power Feed Motor		1
11	F05007-12	Screw, 3/8-16 X 1/2" Cup Point Socket Set		2
12	F05005-101	Bolt, 1/4-20 X 1" Hex Head Grade 5		3
13	F05011-14	Washer, 1/4" Split Lock		3

# 7 Feed System & Track Rollers

Power Feed Assembly

REF	PART #	DESCRIPTION	COMMENTS	QTY.
14	F05011-11	Washer, 1/4" SAE Flat		3
15	012797	Bearing, 1 1/2" Cam Follower		1
16	F05011-5	Washer, 5/8" SAE Flat		6
17	F05010-11	Nut, 5/8-11 Hex Jam		1
18	W11613	Guard, Power Feed Belt		1
19	F05011-14	Washer, 1/4" Split Lock		2
20	F05005-7	Bolt, 1/4-20x2 1/2 HH	ECN 35988:F05005-7 Replaced (2) F05005-32, Added (2) F05011-11	2
21	024431	Decal, Disconnect Motor Leads Warning		1
22	F05007-6	Bolt, 3/8-16 X 3 1/2" Hex Head Grade 8		2
23	F05011-36	Washer, 3/8" Star Lock		2
24	F05011-3	Washer, 3/8" SAE Flat		2
25	F05011-11	Washer, 1/4 SAE Flat <sup>1</sup>		2



### 7.3 Feed Chain/Stop and Taillight

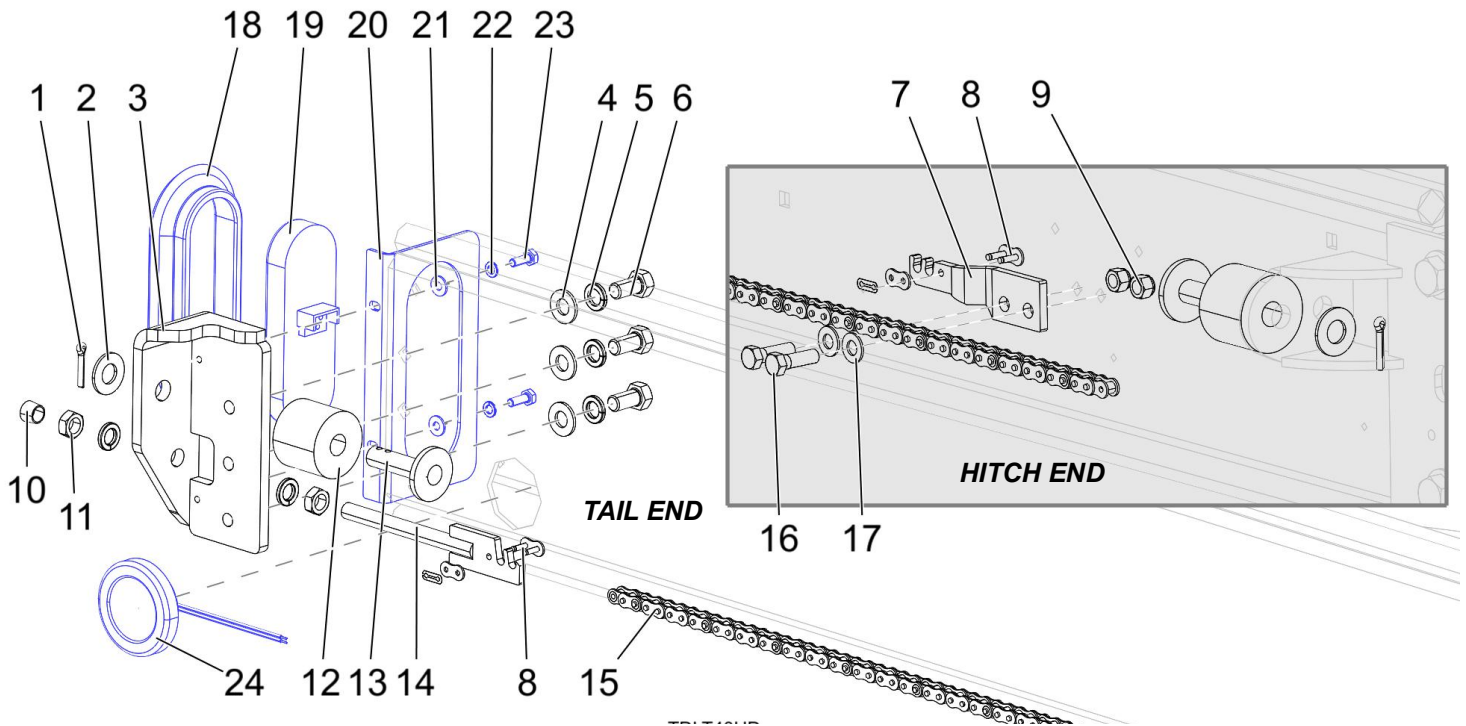

REF	PART #	DESCRIPTION	COMMENTS	QTY.
1	F05012-21	Pin, 3/16x1 Cotter, Zn		1
2	F05011-5	Washer, 5/8 SAE Flat		1
3	006686	Stop Weldment, 3/8 Tail		1
4	F05011-2	Washer, 1/2 SAE Flat		3
5	F05011-9	Washer, 1/2 Split Lock		5
6	F05008-128	Bolt, 1/2-13x1 HH Gr8		3
7	015008	Bracket, Feed Chain		1
8	P04200	Link, #40 Master		2
9	F05010-10	Nut, 3/8-16 Hex Nyl Lock		1
10	P22320	Plug, 1/2 Dia Cap		1
11	F05010-16	Nut, 1/2-20 Hex Jam		2
12	P12165	Bushing, 11/16x2 1/8x1 3/4 Rubber		1
13	W09293	Stop Weldment, Carriage Ptd		1
14	015721	Tensioner Weldment, Power Feed Chain		1
15	014745	Chain, 40 Roller 267 1/2		1
16	F05007-2	Bolt, 3/8-16x1 1/4 HH Gr2		1
17	F05011-3	Washer, 3/8 Flat SAE		1
18	006688	Grommet, 6 1/2 Light Mounting		1
19	074710	Light, 7 Diode LED Tail		1
20	057822	End Cap, Bed Tube w/ Light		1
21	F05011-11	Washer, 1/4 SAE Flat		2
22	F05011-14	Washer, 1/4 Split Lock		2
23	F05005-1	Bolt, 1/4-20x3/4 FT HHC		2
24	P12913	Lamp, Running Red Recessed		1

## 7.4 Lower Track Rollers

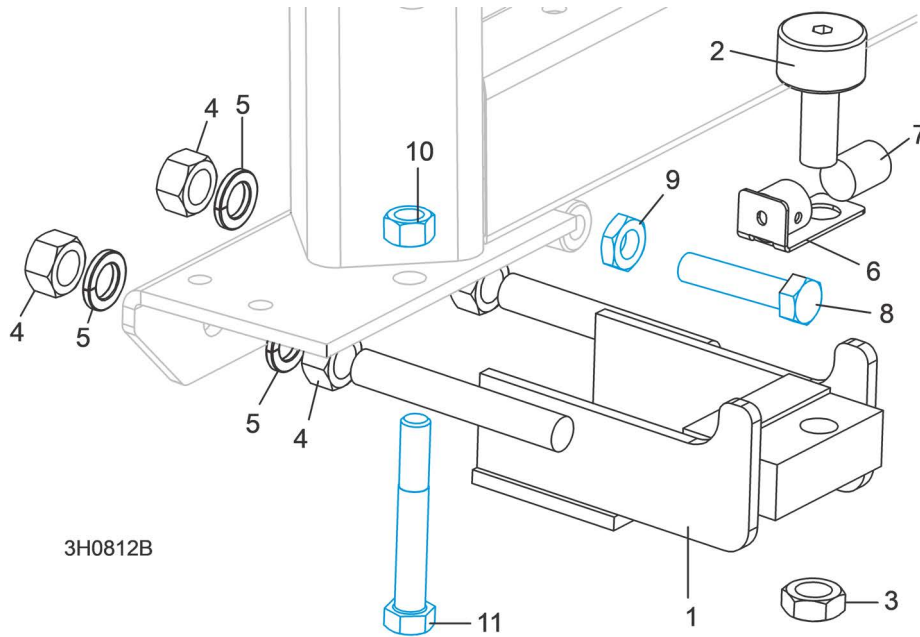

REF	PART #	DESCRIPTION	COMMENTS	QTY.
	012995	Roller Assembly, Lower Track		2
1	012982	Bracket, Lower Track Roller Mounting	Available in assemblies only.	1
2	012797	Roller, Track Cam Bearing		1
3	F05010-11	Nut, 5/8-18 Hex Jam		1
4	F05010-5	Nut, 5/8-11 Hex		4
5	F05011-118	Washer, 5/8" Split Lock Grade 8		4
6	033374	Bracket Weldment, Lower Track Roller Wiper		1
7	033375	Wiper, Round Gray Felt		1
8	F05008-2	Bolt, 1/2-13 x 2 1/4" Hex Head Full Thread		2
9	F05010-31	Nut, 1/2-13 Hex Jam		2
10	F05010-3	Nut, 1/2-13 Hex Lock		2
11	F05008-61	Bolt, 1/2-13 x 3 1/2" Hex Head Grade 5		2

## SECTION 8 BED FRAME ASSEMBLY

### 8.1 Bed Rail Assembly, Front And Rear

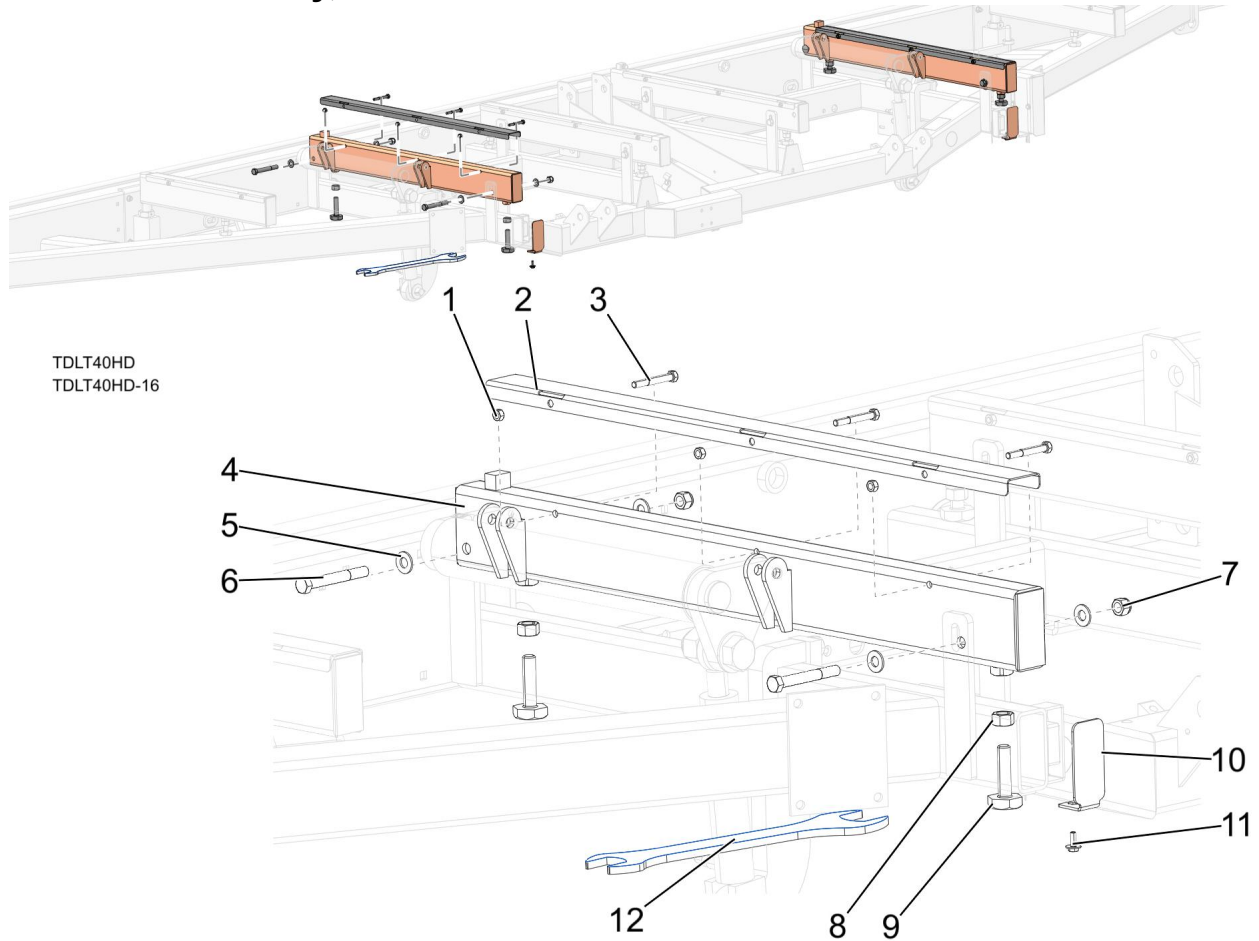

REF	PART #	DESCRIPTION	COMMENTS	QTY.
	079144	Kit, Front/Rear Bed Rail SS Cover		1
1	F05010-6	Nut, 5/16-18 Swaged Hex		6
2	016898	Cover, 36-1/4 Rail SS		2
3	F05006-10	Bolt, 5/16-18x2 1/2 HH Gr2		6
4	014455	Bedrail Weldment, 1996 Front Hyd	Front	1
	014467	Bedrail Weldment, 1996 Rear Hyd	Rear	
5	F05011-2	Washer, 1/2 SAE Flat		7
6	F05008-78	Bolt, 1/2-13 x 4 HHB GR5 ZINC	Front	3
	F05008-94	Bolt, 1/2-13x3 1/2 Carriage	Rear	
7	F05010-8	Nut, 1/2-13 Nyl Hex Lock		4
8	F05010-5	Nut, 5/8-11 Hex		4
9	S13006	Bolt, Bed Rail Adj LT50		4
10	038843	Plate, Formed 2x4 Bed Cap		1
11	F05005-134	Bolt, 1/4-20x3/4 W/Conical Washer		1
12	015970	Wrench, Bed Rail Adjustment	<b>OPTIONAL</b>	1

## 8.2 Bed Rail Assembly, Middle Front

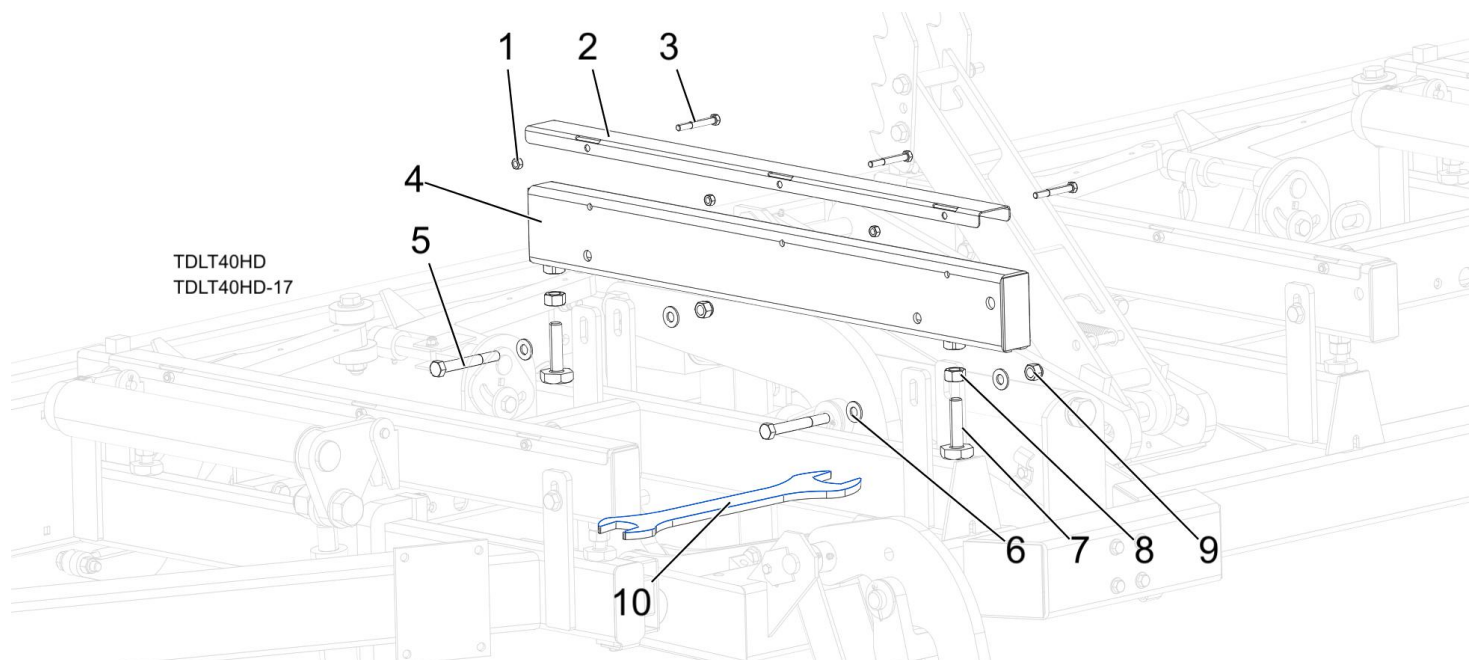

REF	PART #	DESCRIPTION	COMMENTS	QTY.
	079144	Kit, Front/Rear Bed Rail SS Cover		1
1	F05010-6	Nut, 5/16-18 Swaged Hex		3
2	S09944	Cover, 33 Rail SS		1
3	F05006-10	Bolt, 5/16-18x2 1/2 HH Gr2		3
4	034545	Tube Weldment, Bed Rail 2		1
5	F05008-78	Bolt, 1/2-13 x 4 HHB GR5 ZINC		2
6	F05011-2	Washer, 1/2 SAE Flat		4
7	S13006	Bolt, Bed Rail Adj LT50		2
8	F05010-5	Nut, 5/8-11 Hex		2
9	F05010-8	Nut, 1/2-13 Nyl Hex Lock		2
10	015970	Wrench, Bed Rail Adjustment	<b>OPTIONAL</b>	1

### 8.3 Bed Rail Assembly, Middle Rear

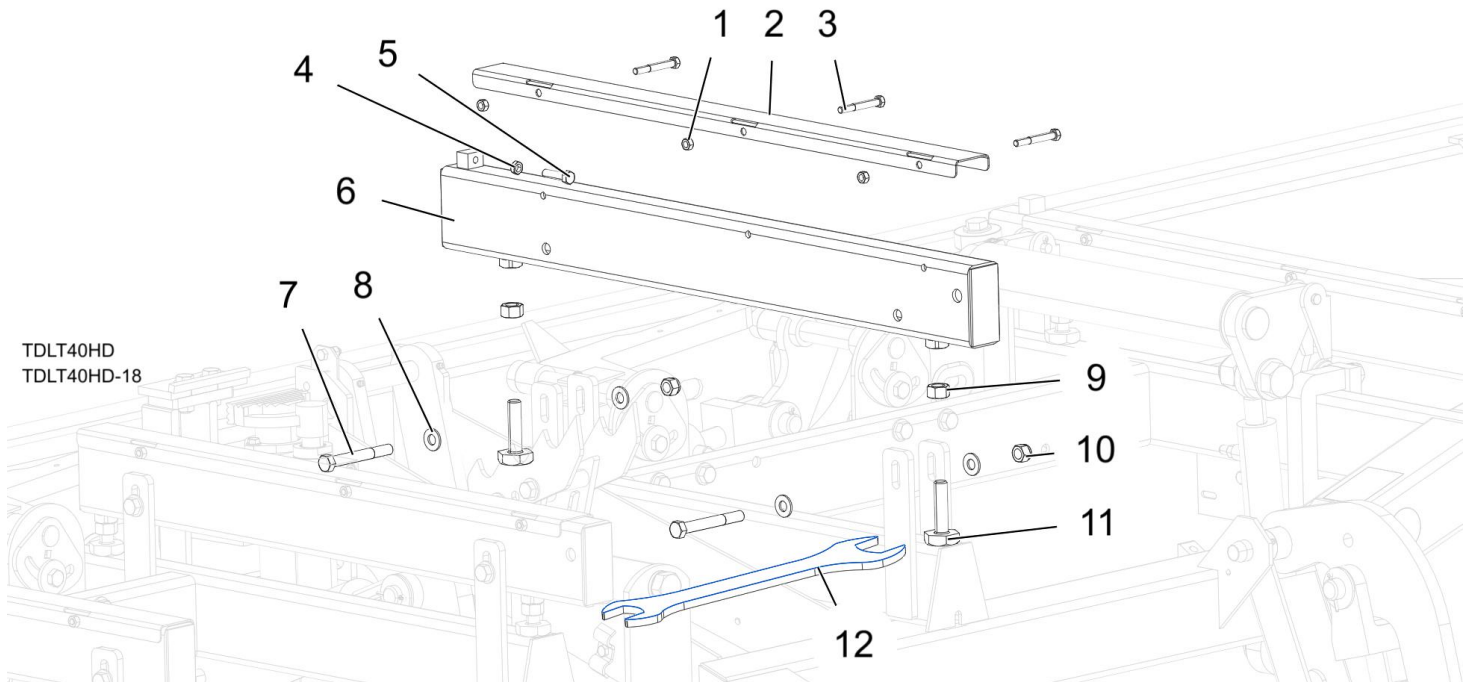

REF	PART #	DESCRIPTION	COMMENTS	QTY.
	079144	Kit, Front/Rear Bed Rail SS Cover		1
1	F05010-6	Nut, 5/16-18 Swaged Hex		3
2	S09944	Cover, 33 Rail SS		1
3	F05006-10	Bolt, 5/16-18x2 1/2 HH Gr2		3
4	F05010-29	Nut, 3/8-16 Jam		1
5	F05007-17	Bolt, 3/8-16 x 1 1/2 HH FT Znc		1
6	015757	Bedrail Assembly, Rear Middle Hyd.		1
7	F05008-78	1/2-13 x 4 HHB GR5 ZINC		2
8	F05011-2	Washer, 1/2 SAE Flat		4
9	F05010-5	Nut, 5/8-11 Hex		2
10	F05010-8	Nut, 1/2-13 Nyl Hex Lock		2
11	S13006	Bolt, Bed Rail Adj LT50		2
12	015970	Wrench, Bed Rail Adjustment	<b>OPTIONAL</b>	1

## 8.4 Pivot Bed Rail Assembly

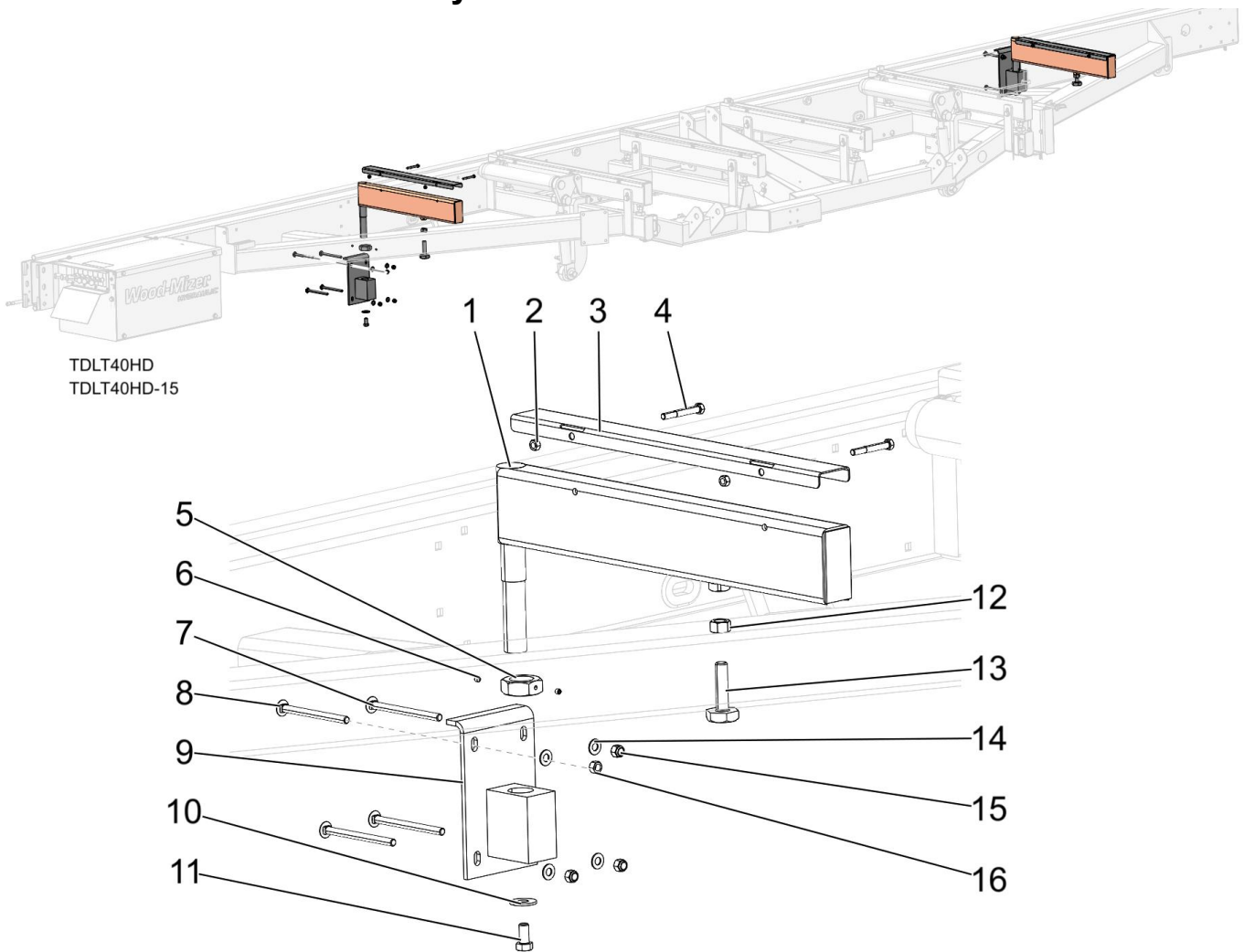

REF	PART #	DESCRIPTION	COMMENTS	QTY.
	A13015	Rail, Front Pivot Assembly	Front and Rear are the same	1
	A13015-R	Rail, Rear Pivot Assembly		1
<b>1</b>	W13014	Pivot Weldment, Long Bed Rail		1
<b>2</b>	F05010-6	Nut, 5/16-18 Swaged Hex		2
<b>3</b>	S13012	Cover, 22.75 SS LT50 Pivot		1
<b>4</b>	F05006-10	Bolt, 5/16-18x2 1/2 HH Gr2		2
<b>5</b>	F05010-100	Nut, 1 1/4-12 Jam		1
<b>6</b>	F05005-42	Screw, 1/4-28x1/4 Brass Tip		2
<b>7</b>	F05007-113	Bolt, 3/8-16x5 Carriage		3
<b>8</b>	F05007-114	Bolt, 3/8-16x4 3/4 Carriage		1
<b>9</b>	W13090	Mount Weldment, Pivot Bed Rail		1
<b>10</b>	F05011-52	WASHER, 9/16 FLAT ZINC		1
<b>11</b>	F05008-50	Bolt, 1/2-13x1 HH Gr2		1
<b>12</b>	F05010-5	Nut, 5/8-11 Hex		1
<b>13</b>	S13006	Bolt, Bed Rail Adj LT50		1
<b>14</b>	F05011-3	Washer, 3/8 Flat SAE		4
<b>15</b>	F05010-10	Nut, 3/8-16 Hex Nyl Lock		3
<b>16</b>	F05010-25	Nut, 3/8-16 Swaged		2

## 8.5 Log Side Support Assembly (Manual)

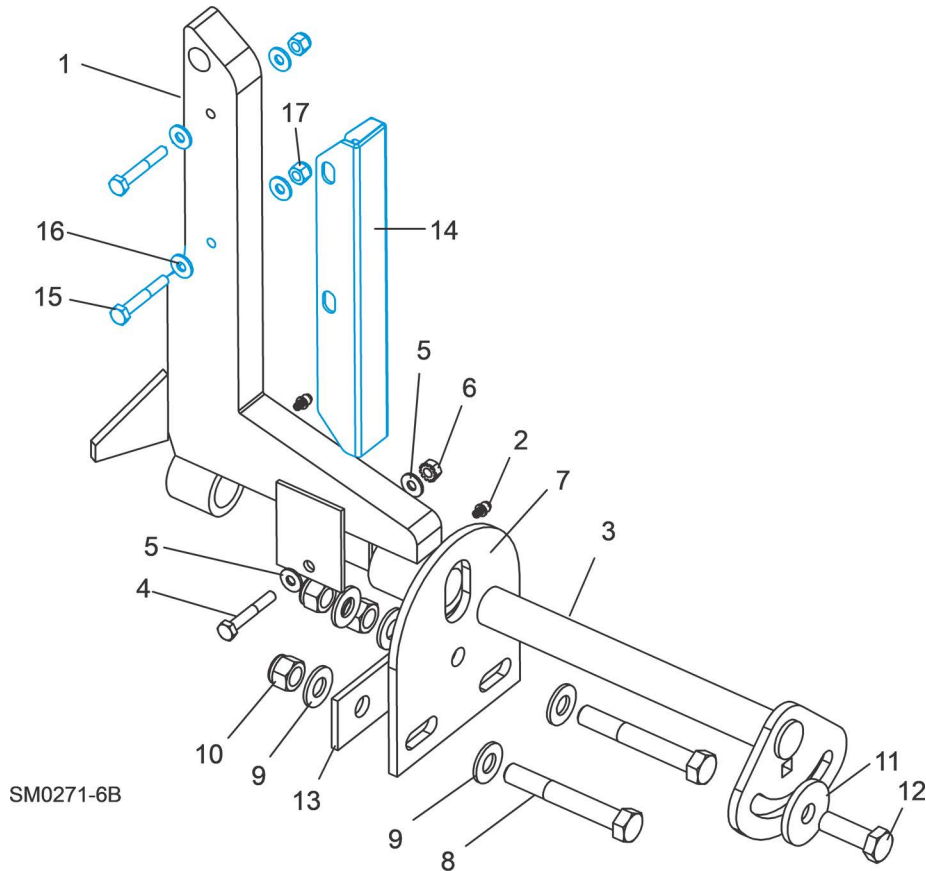

REF	PART #	DESCRIPTION	COMMENTS	QTY.
	034554	Support Assembly, Side, Manual		
1	015235	Support, Log Side		2
2	P04107	Fitting, 3/16" Grease		2
3	016544	Pin, Log Side Support Pivot		1
4	F05005-4	Bolt, 1/4-20 X 1 1/2" Hex Head Grade 5		1
5	F05011-11	Washer, 1/4" SAE Flat		2
6	F05010-9	Nut, 1/4-20 Self Locking		1
7	016555	Plate, Log Side Support End		1
8	F05008-61	Bolt, 1/2-13 X 3 1/2" Hex Head Grade 5		2
9	F05011-2	Washer, 1/2" SAE Flat		5
10	F05010-8	Nut, 1/2-13 Hex Nylon Lock		3
11	014632	Washer, .52" x 1.69"		1
12	F05008-33	Bolt, 1/2-13 X 1 1/2" Hex Head Grade 5		1
13	016558	Plate, Side Support Washer Clamp		1
	016562	Roller Kit, Side Support		4
	016798	Guard Kit, Stainless Steel Side Support	<b>(OPTIONAL)</b>	1
14	016722	Guard, Stainless Steel Side Support		4
15	F05005-4	Bolt, 1/4-20 x 1 3/4" Hex Head		8
16	F05011-11	Washer, 1/4" SAE Flat		16
	F05011-5	Washer, 5/8" SAE Flat	For extra spacing on the hydraulic supports	4
17	F05010-69	Nut, 1/4-20 Hex Nylon Lock		8
	016798-1005	Instruction Sheet,		1

## 8.6 Transport Safety Chain and Rest Pin

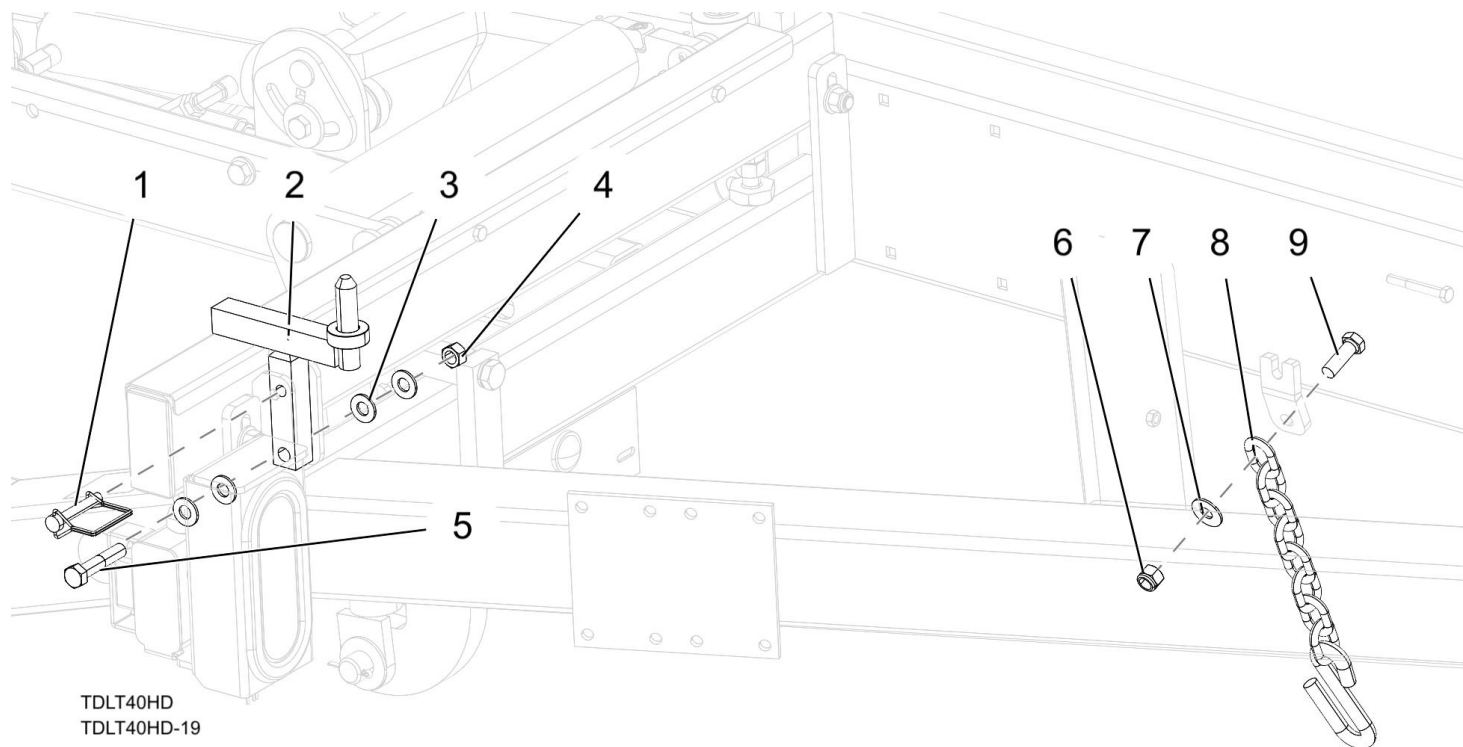

REF	PART #	DESCRIPTION	COMMENTS	QTY.
	079485	Pin Assembly, Rest, 40/50		1
	079511	Pin Assembly, Rest, 40/50 Hyd Wide		
1	014151	Pin, 3/8x2 1/4 SQ Wire Lock		1
2	014102	Pin Weldment, C-Frame Rest 96 Hyd		1
	079510	Pin Weldment, Rest, 40/50 Hyd Wide		
3	F05011-2	Washer, 1/2 SAE Flat		4
4	F05010-3	Nut, 1/2-13 Swaged Hex		1
5	F05008-74	Bolt, Hex Head 1/2-13x2 1/2 Gr5 Zinc		1
6	F05010-8	Nut, 1/2-13 Nyl Hex Lock		1
7	F05011-35	Washer, 7/16 Standard Flat		1
8	107972	Chain, 15 Inch Safety		1
9	F05008-33	Bolt, 1/2-13x1 1/2 HH Gr5		1



## 8.7 Bed Frame Decals

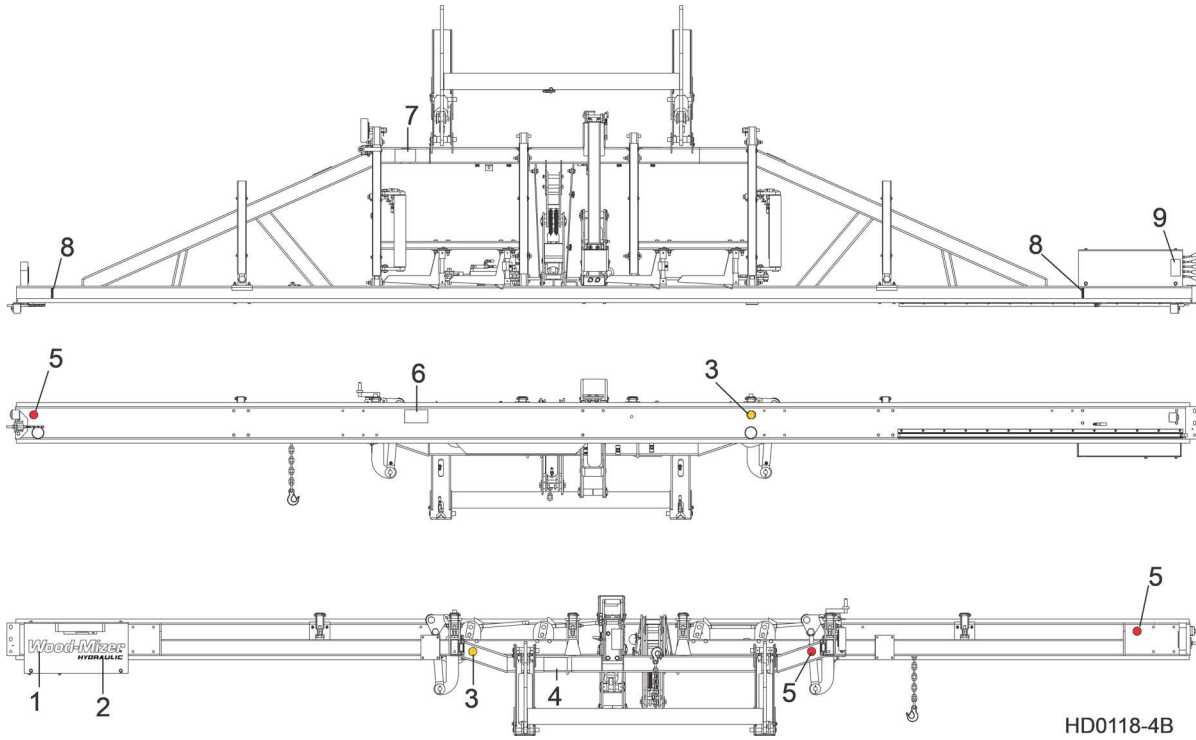

REF	PART #	DESCRIPTION	COMMENTS	QTY.
1	065034	DECAL, WHITE WOOD-MIZER EURO LOGO		1
2	065035	DECAL, HYDRAULIC EURO LOGO BLACK	For standard hydraulic mills	1
	065036	DECAL, HYDRAULIC EURO LOGO BLACK	For super hydraulic mills	1
3	P07453	DECAL, AMBER REFLECTIVE 2" ROUND		2
4	S09851	DECAL, KEEP AWAY DANGER		1
5	P07452	DECAL, RED REFLECTIVE 2" ROUND		3
6	P10287	DECAL, PINCH POINT DANGER		1
7	S12581	DECAL, SAW HEAD REST CAUTION		1
8	S12051	DECAL, LOG LIMIT STRIPE		2
9	P12961	DECAL, KEEP AWAY HYDRAULIC WARNING		1

## 8.8 Cable Chain Assembly

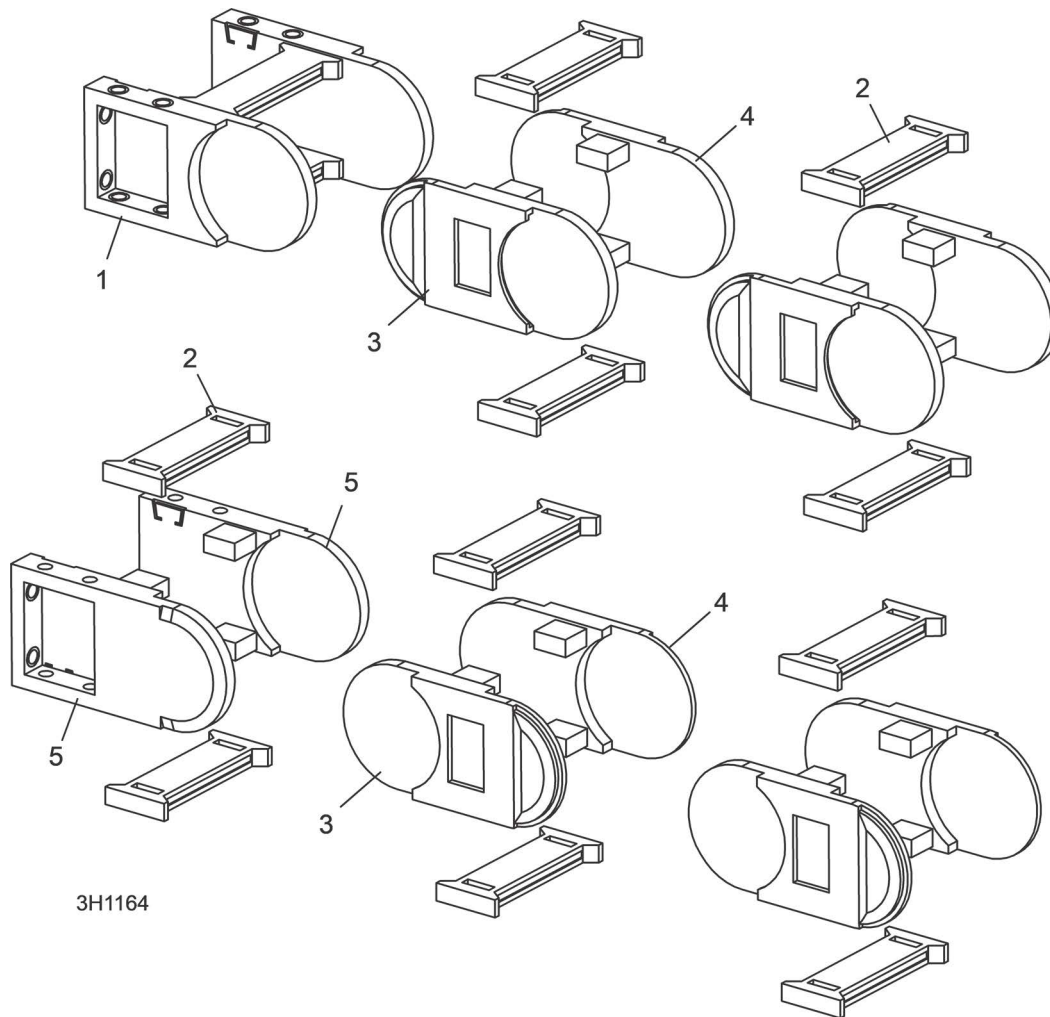

REF	PART #	DESCRIPTION	COMMENTS	QTY.
	074693	<b>CHAIN ASSEMBLY, NYLON REMOTE 196" #4040AX</b>		1
1	023612-3	Link, Nylon Chain Top Mount		2
2	023612-4	Brace, Nylon Chain Long Cross		55
3	061154	Link, Nylon Chain Right Side (For 074693)		52
4	061155	Link, Nylon Chain Left Side (For 074693)		52
5	023612-9	Link, Nylon Chain Bottom Mount		2

## 8.9 Energy Chain (Cat Track) Mounts

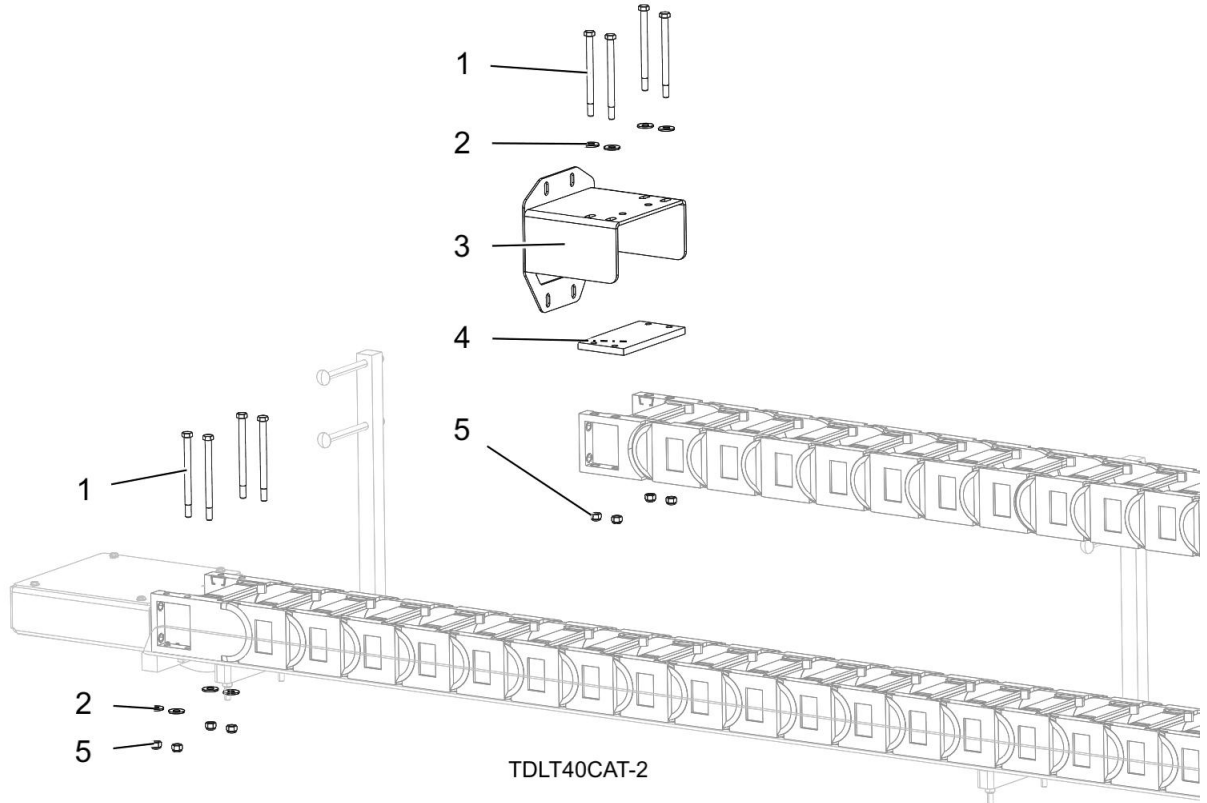

REF	PART #	DESCRIPTION	COMMENTS	QTY.
1	F05006-82	Bolt, 5/16-18x3/4 HH Gr2		8
2	F05011-16	Washer, 5/16 Standard Flat		8
3	023610	Bracket Weldment, Plastic Track Mtg		1
4	023606	Plate, Plastic Chain Spacer		1
5	F05010-58	Nut, 5/16-18 Nyl Lock		8

## 8.10 Energy Chain (Cat Track) Tray

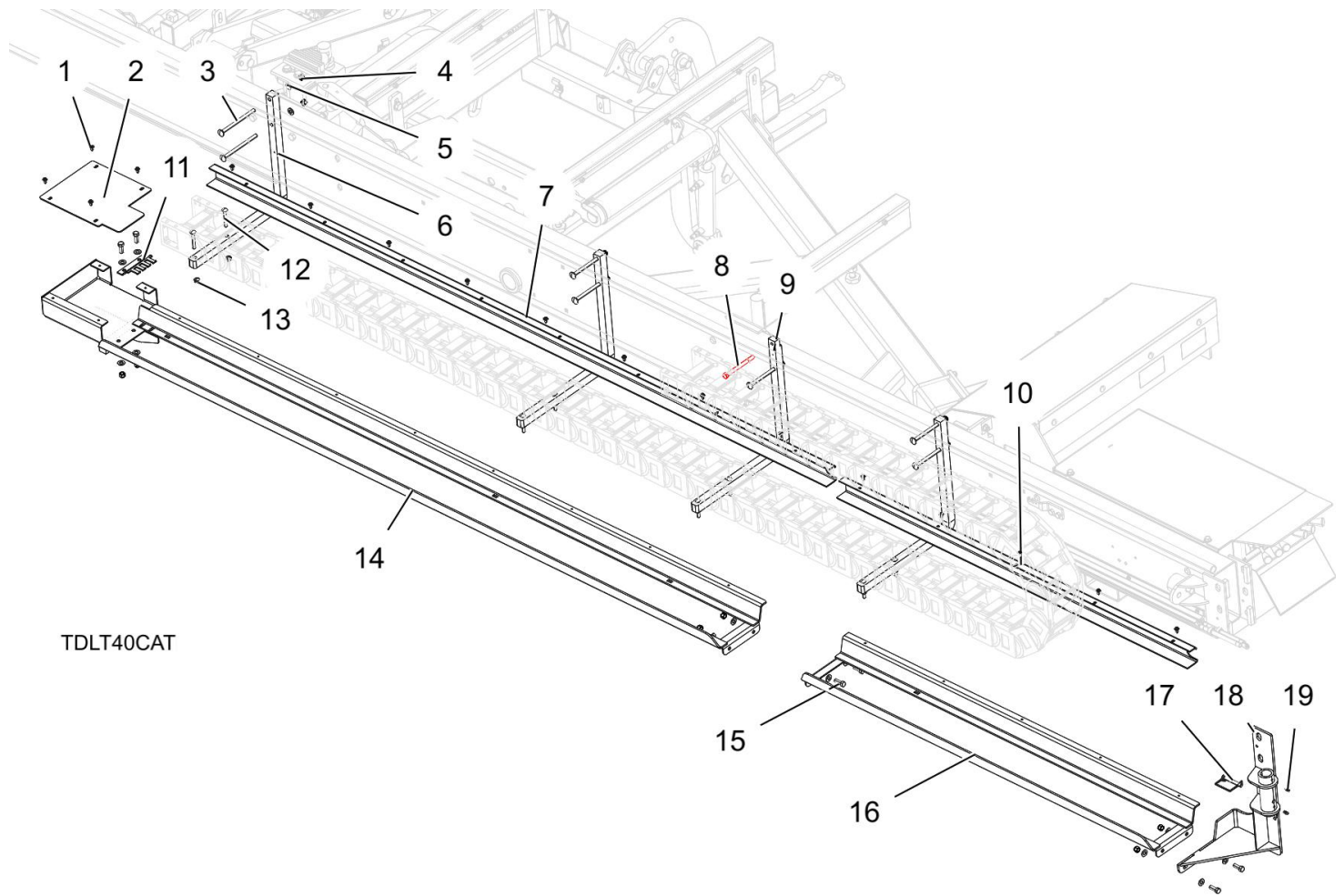

TDLT40CAT

REF	PART #	DESCRIPTION	COMMENTS	QTY.
	128102	Assembly, Cat Track Tray		1
1	F05015-1	Bolt, 1/4-20x1/2 SI HH		17
2	015578	Cap, LT30/LT40 Track Box		1
3	F05007-31	Bolt, 3/8-16 x 5 1/2 Carriage Head		7
4	F05010-10	Nut, 3/8-16 Hex Nyl Lock		13
5	F05011-3	Washer, 3/8 Flat SAE		19
6	128042	Square, LT40 Track Mount		3
7	015599	Wireway, Long		1
8	F05007-35	Bolt, 3/8-16x4 1/2 Hex Head Gr5 Zinc	Note: shorter than other bolts	1
9	128044	Square, LT40 Track Mount Tapped	Note: Different than others	1
10	042750	Wireway, 53 11/16 Long		1
11	023604	Plate, Conduit Clamp		1
12	F05006-61	Bolt, 5/16-18x2 1/4 Carriage FT		8
13	F05010-221	Nut, 5/16-18 Flanged Hex Nylock		8
14	128052	Weldment, Cat Track Long		1
15	F05007-7	Bolt, 3/8-16x1 HH		6
16	128049	Weldment, Cat Track Tray 53-3/4		1
17	014151	Pin, 3/8x2 1/4 SQ Wire Lock		1
18	016193	Hanger Weldment, Remote Pivot		1
19	P05060	Fitting, 1/4-28 Grease		2

8.11 Energy Chain Transport Bracket

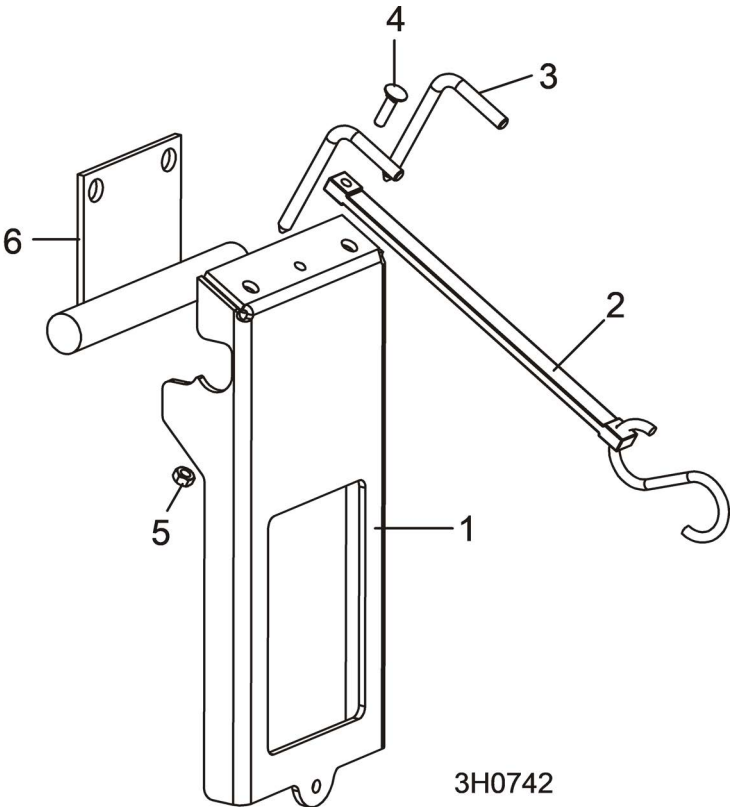

REF	PART #	DESCRIPTION	COMMENTS	QTY.
	023586	Bracket Assembly, Remote Cable Chain Support		1
1	023588	Bracket Weldment, Remote Cable Chain Support	Available in assemblies only.	1
2	012965	Strap, 11 1/2" Rubber		1
3	023602	Handle, Remote Cable Chain Support Lock		2
4	F05005-34	Bolt, 1/4-20 x 1" Carriage Head		1
5	F05010-21	Nut, 1/4-20 Hex Lock		1
6	023589	Bracket Weldment, Chain Support Storage		1

## 8.12 Board Return Table Assembly

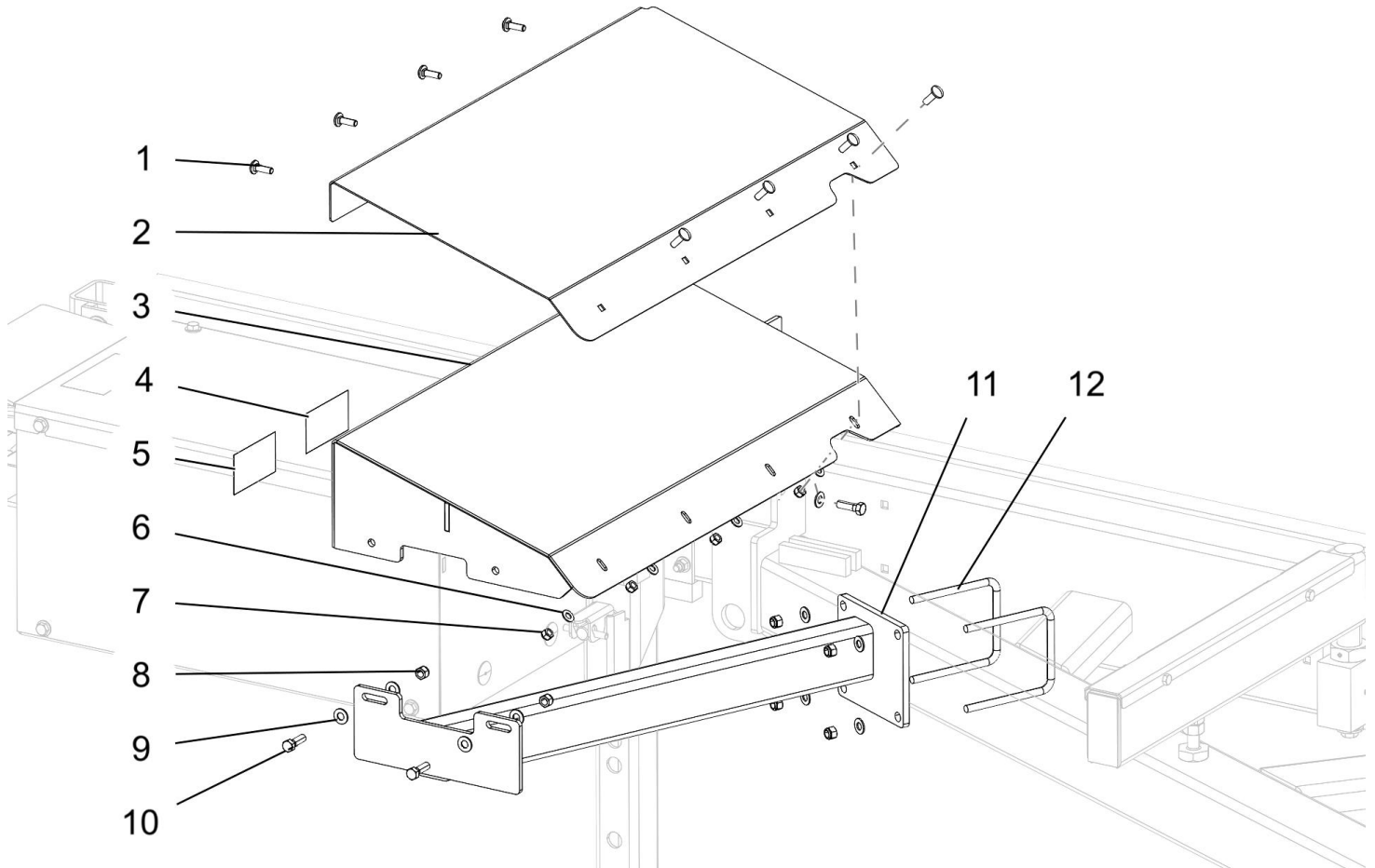

REF	PART #	DESCRIPTION	COMMENTS	QTY.
	003264	Table Assembly, Board Return	Optional for LT40HD standards	1
1	F05006-9	Bolt, 5/16-18x1 Carriage		8
2	003259	Cover, Board Return Table		1
3	055515	Table Weldment, Board Return		1
4	015365	Decal, Board Return Danger		1
5	016077	Decal, Board Return Table Warning		1
6	F05011-17	Washer, 5/16 SAE Flat		8
7	F05010-58	Nut, 5/16-18 Nyl Lock		8
8	F05010-10	Nut, 3/8-16 Hex Nyl Lock		7
9	F05011-3	Washer, 3/8 Flat SAE		10
10	F05007-123	Bolt, 3/8-16x 1 1/4 HH Gr5		3
11	055533	Mount Weldment, Board Return, LT40		1
12	003207	U-Bolt, 3/8-16x4x5		2

### 8.13 Board Outfeed Table (Optional)

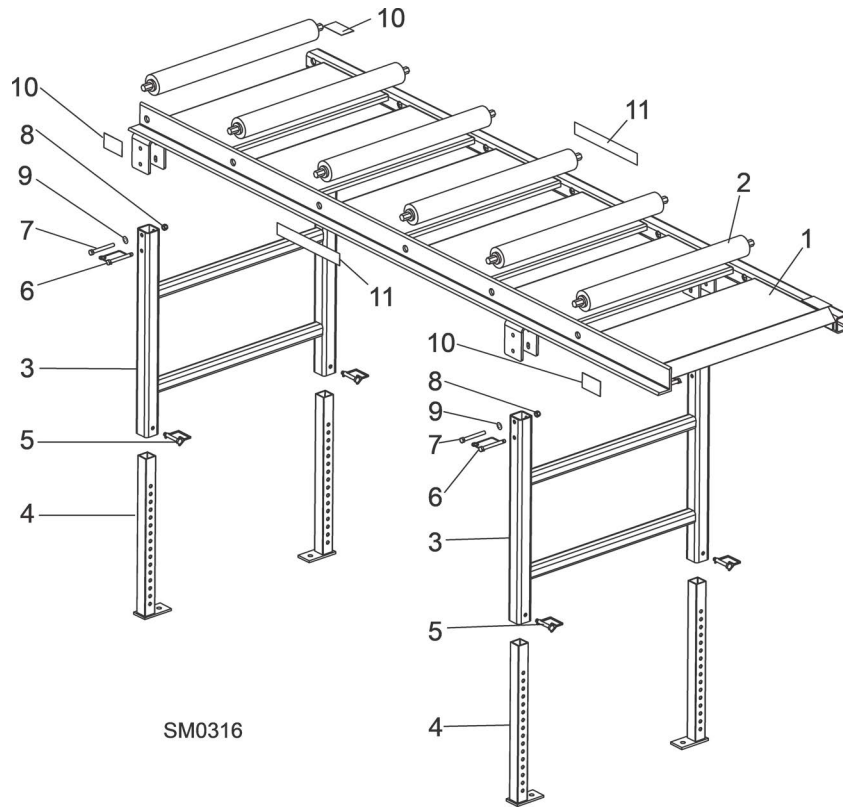

REF	PART #	DESCRIPTION	COMMENTS	QTY.
	016652	<b>TABLE ASSEMBLY, BOARD OUTFEED</b>		1
1	016606	Table Weldment, Board Outfeed		1
2	038167	Roller, 2 1/2" x 25"		6
3	016609	Mount Weldment, Outfeed Table Leg		2
4	016651	Leg Weldment, Outfeed Table		4
5	014151	Pin, 3/8" x 2 1/4" Square Wire Lock		4
6	016677	Pin, Snap - Coil Tension		4
7	F05007-135	Bolt, 3/8-16 x 3 1/4" Hex Head		4
8	F05010-10	Nut, 3/8-16 Hex Nylon Lock		4
9	S12641	Decal, Hand Pinch Point Warning		4
10	016991	Decal, 1 1/2" Wood-Mizer Logo		2

## SECTION 9 BED HYDRAULIC SYSTEM

### 9.1 Hydraulic Hoses

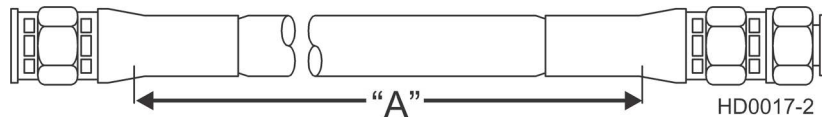

REF	COLOR	LENGTH "A"		DESCRIPTION (NOTE: See Hydraulic Information Section in Operator's Manual for Hydraulic Schematics)	PART #	QTY.
		MFG SPEC	ACTUAL PART			
H1	None	9"	9"	1/4" Hydraulic Pump To Valve	079000-9	1
H2	Plain	27"	27"	Log Turner Base	079000-27	1
H3	Orange	18"	18"	Log Turner Top	079000-18	1
H4	Yellow	117"	117"	Front Toe Board Top	079000-117	1
H5	Gray	117"	117"	Front Toe Board Base	079000-117	1
H6	Pink	181"	181"	Side Support Base	079000-181	1
H7	Plain	181"	181"	Side Support Top	079000-181	1
H8	White	155"	157"	Clamp In/Out Top	079000-157	1
H9	Dark Orange	147"	151"	Clamp In/Out Base	079000-151	1
H10	Purple	219"	219"	Rear Toe Board Top	079000-219	1
H11	Black	219"	219"	Rear Toe Board Base	079000-219	1
H12	Green	62"	62"	Loading Arm Branch Top	079000-62	2
H13	Yellow	64"	64"	Loading Arm Branch Base	079000-64	2
H14	Blue	186"	186"	Loading Arm Top	079000-186	1
H15	Red	186"	186"	Loading Arm Bottom	079000-186	1
H16	Green	204"	204"	1/4" Clamp Up/Down Top	079000-204	1
H17	Yellow	193"	194"	1/4" Clamp Up/Down Base	079000-194	1
				Grommet, 2 1/2" Diameter Rubber	085614	2
				Grommet, 1 x 1 3/4" Oval Rubber	085613	2



## 9.2 Command Control

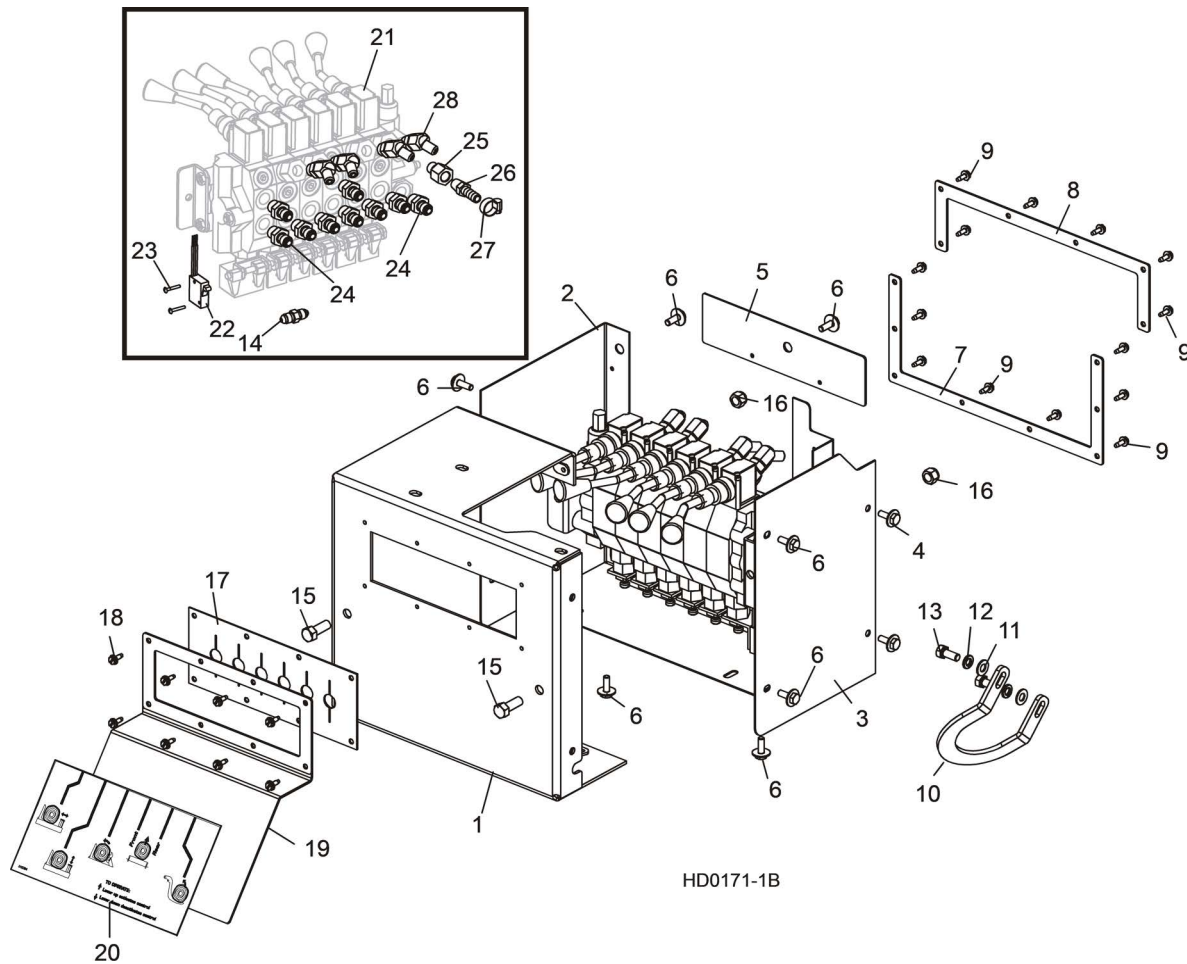

HD0171-1B

REF	PART #	DESCRIPTION	COMMENTS	QTY.
1	016521	Cover Weldment, Command Control Front		1
	016522	Cover Assembly, Command Control Rear		1
2	017839	Cover Weldment, Command Control Rear		1
3	017837	Cover Plate, Command Control Rear		1
4	F05005-134	Bolt, 1/4-20 x 3/8" Conical Washer Head		2
5	016527	Plate, Command Control Rear		1
6	F05005-134	Bolt, 1/4-20 x 3/4" Conical Washer Head		8
7	016528	Bracket, Boot Mount Bottom		1
8	016526	Bracket, Boot Mount Top		1
	016538	Boot, Command Control Hose		1
9	F05015-7	Screw, #10-24 x 1/2" Self-Tapping		19
10	016525	Bracket, Hose Hanger		1
11	F05011-17	Washer, 5/16" SAE Flat		2
12	F05011-13	Washer, 5/16" Split Lock		2
13	F05006-102	Bolt, 5/16-18 x 3/4" Hex Head Grade 5		2
	016728	Sleeve, 8 1/2" x 55" Zippered		1
14	016539	Fitting, 1/4" JIC x 1/4" JIC Small Hex Union	(for 1/4" Extension Hoses)	13
15	F05007-7	Bolt, 3/8-16 x 1" Hex Head		2

REF	PART #	DESCRIPTION	COMMENTS	QTY.
16	F05010-10	Nut, 3/8-16 Hex Nylon Lock		2
17	015079	Seal, Rubber valve handle		1
18	F05015-7	Screw, #10-24 x 1/2 Slotted Hex Self-Tapping		8
19	015078	Plate, Valve Handle Decal		1
20	015364	Decal, 1997 hydraulic Control Box		1
21	015260	Valve, Hydraulic 6 Section	(See Form 575 for service parts)	1
22	024198	Switch, Hydraulic Valve Electric		1
23	F05004-13	Screw, #4-40 x 3/4" Slotted		2
24	P26284	Fitting, 3/8" O-Ring - 1/4" jic		9
25	014686	Fitting, #6 SAE Male - 1/4" NPT Female		1
26	014685	Fitting, 1/4" NPT x 3/8" Hose Barb		1
27	P12739	Clamp, 11/16" Hose		1
28	015488	Fitting, #6 SAE - 1/4" JIC 45° Elbow		4

9.3 Hydraulic Pump Box

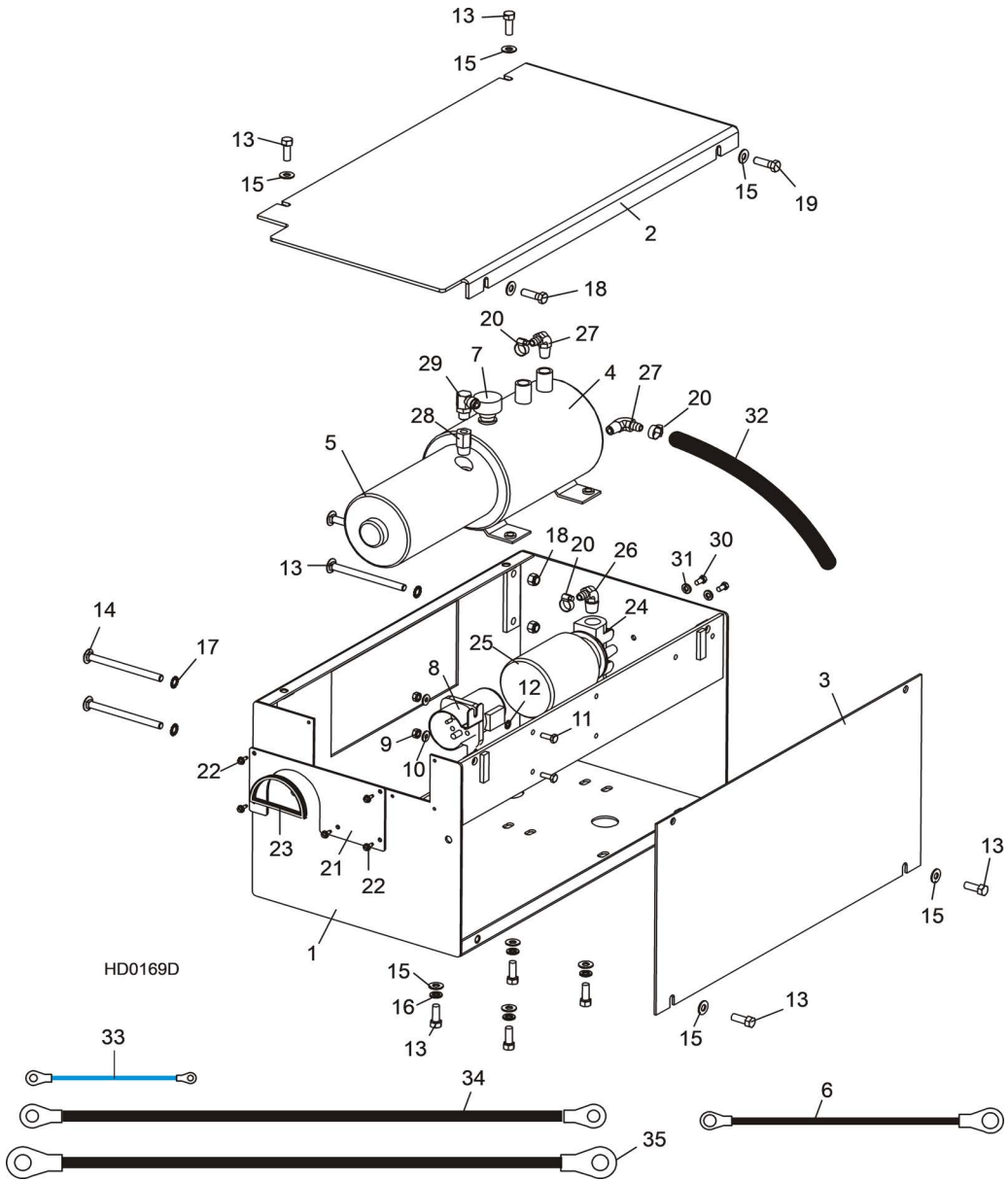

REF	PART #	DESCRIPTION	COMMENTS	QTY.
1	015027	Box Weldment, Super Hydraulic Pump Housing		1
2	015228	Cover, Super Hydraulic Pump Housing Top		1
3	015227	Cover, Super Hydraulic Pump Housing Side		1
4	061764	Pump Kit, Hydraulic w/Motor		1
	016199	Pump, Hydraulic Replacement Monarch Model #12070		1
	052807	Motor Kit, Hydraulic Replacement		1
5	038683	Motor, 12 VDC Hydraulic Pump #08714 (Iskra)	Available in assemblies only.	1
	038682	Brush Kit, 4-Valve Hydraulic Pump Motor #08658-I (Iskra)		1
	P12513	Bearing, Base Motor #02318		1
6	052806	Wire Assembly, Motor Brush Ground		1
7	P12817	Cap, Hydraulic Pump Vented Fill #03171		1

REF	PART #	DESCRIPTION	COMMENTS	QTY.
	P10198	O-Ring, Hydraulic Pump/Reservoir #02352		1
	P10315	Seal, Hydraulic Pump/Motor #02330		1
<b>8</b>	016371	Solenoid kit, 200A 12V SPST Hydraulic Pump Motor		1
	015470	Solenoid, 200A 12V SPST Cont. Duty	Available in assemblies only.	1
	015426	Diode Assembly, Solenoid Coil Chassis Gnd		1
<b>9</b>	F05010-9	Nut, 1/4-20 Self-Locking Hex		2
<b>10</b>	F05011-11	Washer, 1/4" SAE Flat		2
<b>11</b>	F05005-1	Bolt, #1/4-20 x 3/4" Hex Head Full Thread		2
<b>12</b>	F05011-37	Washer, 1/4" Exterior Star Lock		2
	P12742	Fluid, 1-QUart dexron III hydraulic		2 1/4 gal.
	006397	Fluid, 1-Gallon Conoco MV32		2 1/4 gal.
	P12822	Fluid, 1-Gallon Exxon Univis HVI 13 HYdraulic		2 1/4 gal.
<b>13</b>	F05007-87	Bolt, 3/8-16 X 1" Hex Head Grade 5		8
<b>14</b>	F05007-113	Bolt, 3/8-16 X 5" Carriage Head		4
<b>15</b>	F05011-3	Washer, 3/8" Sae Flat		10
<b>16</b>	F05011-4	WASHER, 3/8" Split lock		4
<b>17</b>	F05011-36	Washer, 3/8" External Star Lock		4
<b>18</b>	F05010-10	Nut, 3/8-16 Hex Nylon Lock		4
<b>19</b>	F05007-2	Bolt, 3/8-16 x 1 1/4" Hex Head		2
<b>20</b>	P12739	Clamp, 11/16" Hose		4
<b>21</b>	016523	Plate, Hydraulic Box Cover		1
<b>22</b>	F05015-7	Screw, #10-24 x 1/2 Slotted Hex Self-Tapping		5
<b>23</b>	014548	Edging, 3/8" x 1/2" Black rubber		1.46 ft.
<b>24</b>	P22683	Manifold, Hydraulic Cartridge Filter		1
<b>25</b>	P20301	Filter, S28 Hydraulic Cartridge		1
<b>26</b>	P12707	Fitting, #6-8 (1/2" NPT) - 3/8" Hose Barb elbow		2
<b>27</b>	P12708	Fitting, #6-6 (3/8" NPT) - 3/8" Hose Barb Elbow		2
<b>28</b>	015490	Fitting, 3/8" NPT Male - 1/4" NPT Female		1
<b>29</b>	P09142	Fitting, 1/4" NPT - 1/4" JIC Elbow		1
<b>30</b>	F05005-15	Bolt, 1/4-20 x 1/2" Hex Head		2
<b>31</b>	F05011-14	Washer, 1/4" Split Lock		2
<b>32</b>	R01892-1	Hose, 3/8" Low Pressure Hydraulic		A/R
<b>33</b>	036315	Wire Assembly, 14 Ga x 4" #10 & 5/16" Rings		1
<b>34</b>	036310	Cable Assembly, 1 Ga x 16" Hydraulic Pump To Solenoid		1
<b>35</b>	036312	Cable Assembly, 1 Ga x 16" Hydraulic Pump Ground		1

### 9.4 Hydraulic Log Loader

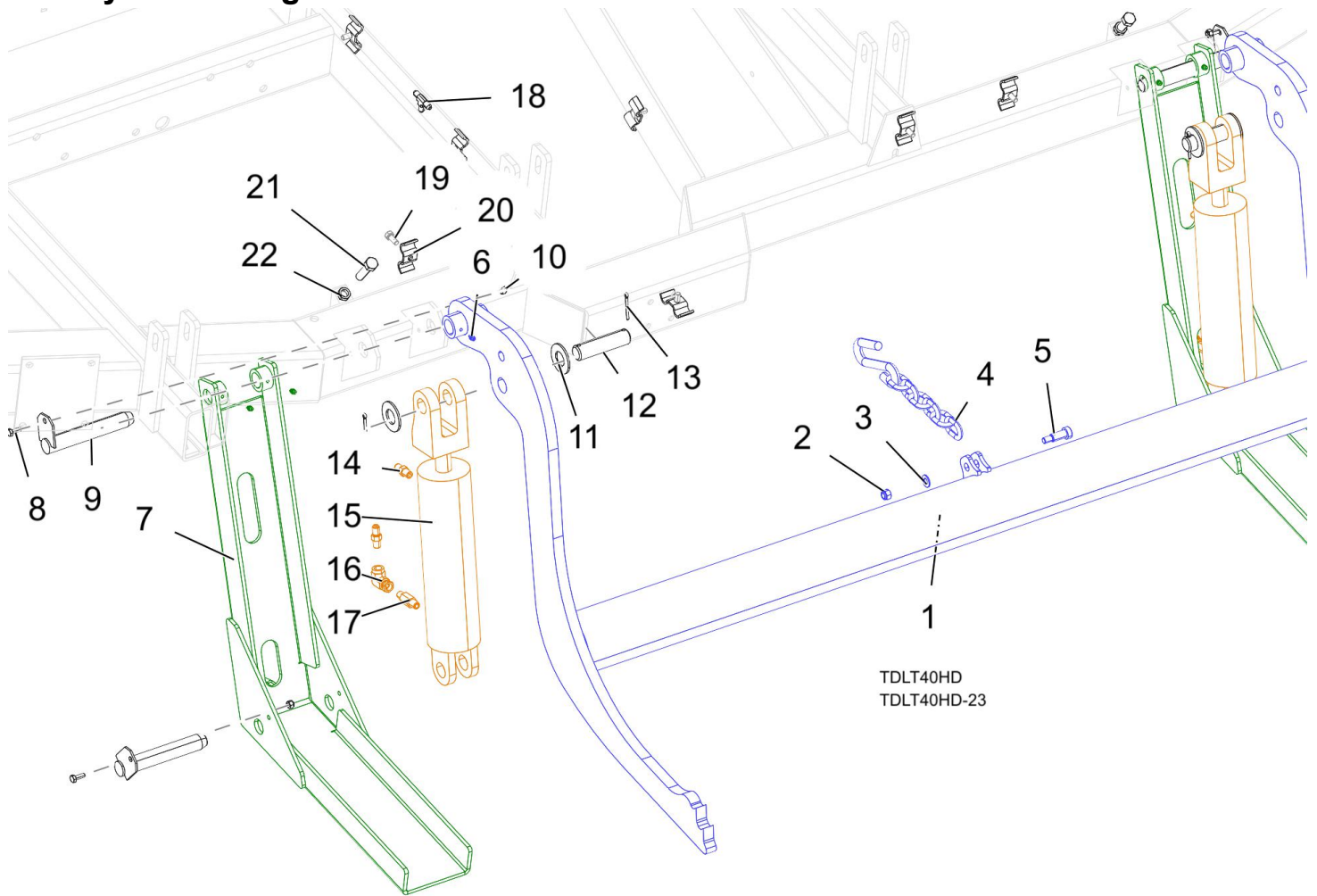

REF	PART #	DESCRIPTION	COMMENTS	QTY.
	079880	Assy, Standard Hydraulic Log Loader		1
	036416	Arm Assy, Log Loading		1
1	110372	Arm Wldmt, Log Loading		1
2	F05010-10	Nut, 3/8-16 Hex Nyl Lock		1
3	F05011-3	Washer, 3/8 Flat SAE		1
4	110472	Chain, 12-1/2 Inch Safety		1
5	F05008-146	Bolt, 1/2x1 Shoulder		1
6	P04107	Fitting, 3/16x3/16 Straight Grease		4
	W09444	Foot Assy, Hyd Loading Arm		2
7	W09208	Foot, U-Channel Wldmt		1
	P04107	Fitting, 3/16x3/16 Straight Grease		2
8	F05005-1	Bolt, 1/4-20x3/4 FT HHC		4
9	W09446	Pin Wdmt, 1x6 7/16		4
10	F05010-69	Nut, 1/4-20 Nylock		4
11	F05011-28	Washer, 1 ID SAE Flat		4
12	S09251	Pin, 1x3.88		2
13	F05012-23	Pin, 3/16 x 1-1/2 Cotter		4
	A09284	Cylinder Assy, 3x8 Loading		1
14	P09143	Fitting, 1/4NPTx1/4JIC Male		2
15	P12847	Cyl, 3x8 Hydraulic		1
	P12956	Seal Kit, 8" x 3" Hydraulic Cylinder	Service Part	1

**9** **Bed Hydraulic System**  
Hydraulic Log Loader

REF	PART #	DESCRIPTION	COMMENTS	QTY.
16	P12199	Fitting, 1/4NPT Fml x 1/4NPT Fml Swvl		1
17	015750	Fitting, 1/4NPT Velocity Fuse 5 GPM		1
	015832	Fitting Kit, 1/4NPT 5.0GPM Velocity Fuse	Service Part	
18	F05006-102	Bolt, 5/16-18 x 3/4 HH Gr5		6
19	S09245	Clamp, 1/4 Hose		6
20	P09145	Fitting, 1/4JIC Union Tee		2
21	F05008-116	Bolt, 1/2-13x2 HHFT GR5 Znc		2
22	F05010-31	Nut, 1/2-13 Zinc Jam		2
	LTHDLA	Arm Kit, LT40HD Log Loader	Service Kit -- contains items 1 thru 20 plus Hose Kit 074863	1
	074863	Hose Kit, Log Loader, LT40HD		1

9.5 Hydraulic Log Turner

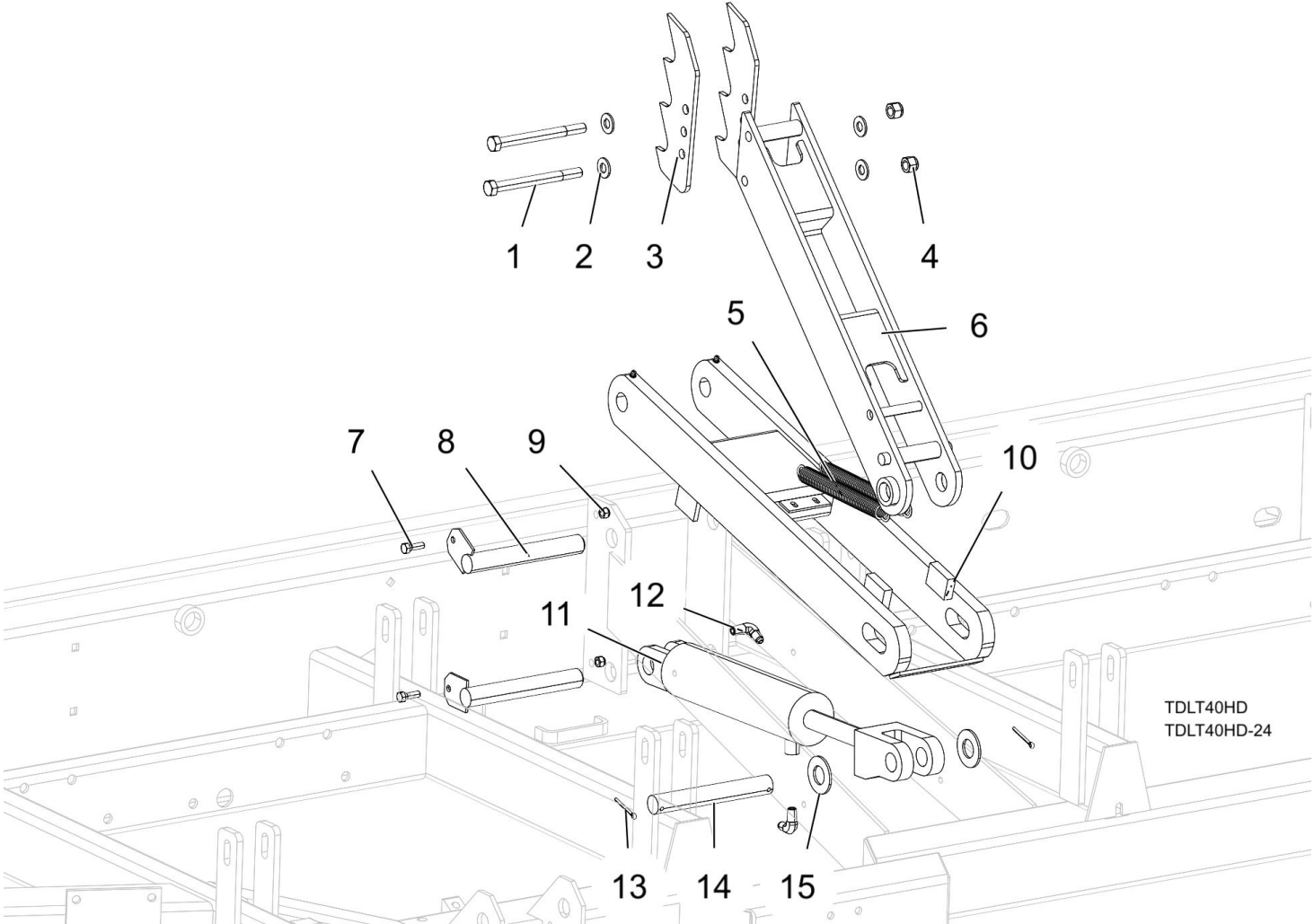

REF	PART #	DESCRIPTION	COMMENTS	QTY.
1	F05008-28	Bolt, 1/2-13x5 1/2 Hex Head GR5 Zinc		2
2	F05011-2	Washer, 1/2 SAE Flat		4
3	014675	Claw, Log Turner Ptd.		2
4	F05010-8	Nut, 1/2-13 Nyl Hex Lock		2
5	015718	Spring, 1 1/16x8x.135 Dia.		2
6	015233	Arm Wdmt, Hyd Turner		1
7	F05006-1	Bolt, 5/16-18x1 HH Gr2		2
8	015085	Pin Wldmt, 1x7 3/16		2
9	F05010-58	Nut, 5/16-18 Nyl Lock		2
10	015231	Link Wdmt, Hyd Log Turner 1997		1
	A09286	Cylinder Assy, 2 1/2x8 Log Turner		1
11	P12846	Cyl, 2-1/2 x 8 Hydraulic		1
12	P09142	Fitting, 1/4NPTx1/4JIC Male Elbow		2
13	F05012-23	Pin, 3/16 x 1-1/2 Cotter		2
14	S09246	Pin, 1x7 1/4		1
15	F05011-28	Washer, 1 ID SAE Flat		2

## 9.6 Hydraulic Log Side Supports

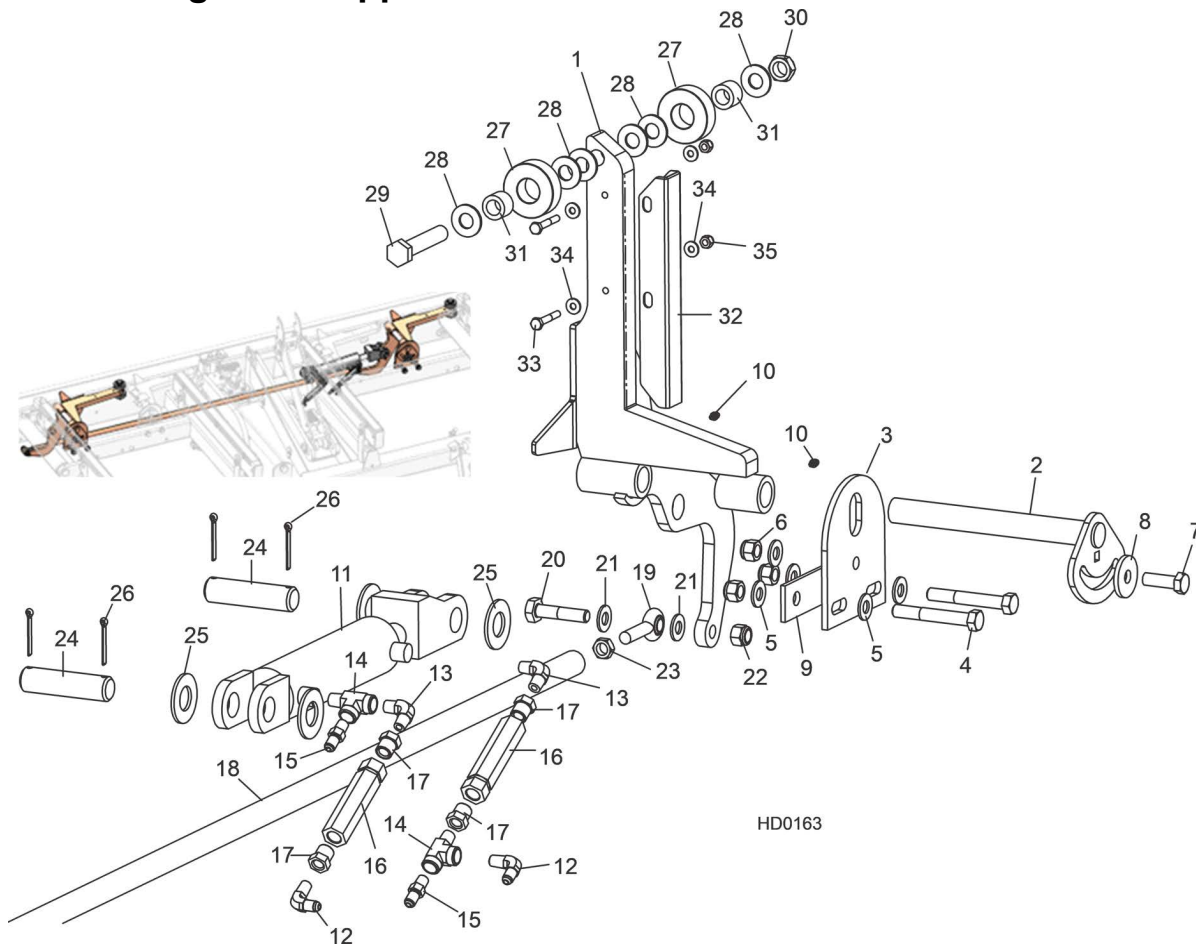

HD0163

REF	PART #	DESCRIPTION	COMMENTS	QTY.
1	015010	Support Weldment, Log Side		2
2	016544	Pin, Log Side Support Pivot		2
3	016555	Plate, Log Side Support End		2
4	F05008-61	Bolt, 1/2-13 X 3 1/2" Hex Head Grade 5		4
5	F05011-2	Washer, 1/2" SAE Flat		10
6	F05010-8	Nut, 1/2-13 Hex Nylon Lock		6
7	F05008-33	Bolt, 1/2-13 X 1 1/2" Hex Head Grade 5		2
8	014632	Washer, .52" x 1.69"		2
9	016558	Plate, Side Support Washer Clamp		2
10	P04107	Fitting, 3/16" Grease		4
	A09283	Cylinder Assembly, Hydraulic Log Side Support		2
11	P12845	Cylinder, 6" X 2" Hydraulic		1
	P12954	Seal Kit, 6" x 2" Hydraulic Cylinder	Service parts	1
12	P09142	Fitting, 90° Male Elbow		2
13	P09140	Fitting, C3529x4 90° Pipe		2
14	P09141	Fitting, C3759x4 Male 'T'		2
15	P09143	Fitting, C5205x4x4 Male Connector		2
16	015484	Valve, Hydraulic Sequence		2
17	015490	Fitting, 3/8" NPT - 1/4" NPT Reducer		4
18	015026	Rod, Hydraulic Side Support Link	(See Section 9.8) if equipped with HSS Option	1
19	P09137	End, 1/2" Rod		2



REF	PART #	DESCRIPTION	COMMENTS	QTY.
20	F05008-10	Bolt, 1/2-13 X 2 1/4" Hex Head Grade 5		2
21	F05011-2	Washer, 1/2" SAE Flat		4
22	F05010-8	Nut, 1/2-13 Hex Nylon Lock		2
23	F05010-16	Nut, 1/2-20 Hex Jam		1
24	S09251	Pin, Cylinder Mount		2
25	F05011-28	Washer, 1" SAE Flat		4
26	F05012-23	Pin, 3/16" X 1 1/2" Cotter		4
	016562	Roller Kit, Side Support	Standard on hydraulic supports only - Optional for manual	2
27	016561	Roller, Side Support		2
28	F05011-5	Washer, 5/8" SAE Flat		6
29	F05009-118	Bolt, 5/8-11 x 3 3/4" Hex Head Grade 5		1
30	F05010-96	Nut, 5/8-11 Hex Nylon Lock Jam		1
31	016560	Bushing, Bronze 5/8" x 1" x 3/4"		2
	016798	Guard Kit, Stainless Steel Side Support	(Optional)	1
32	016722	Guard, Stainless Steel Side Support		4
33	F05005-4	Bolt, 1/4-20 x 1 3/4" Hex Head		8
34	F05011-11	Washer, 1/4" SAE Flat		16
	F05011-5	Washer, 5/8" SAE Flat	For extra spacing on the hydraulic supports	4
35	F05010-69	Nut, 1/4-20 Hex Nylon Lock		8
	016798-1005	Instruction Sheet, Stainless Steel Side Support Guard Retro		1

## 9.7 Hydraulic Log Clamp - base

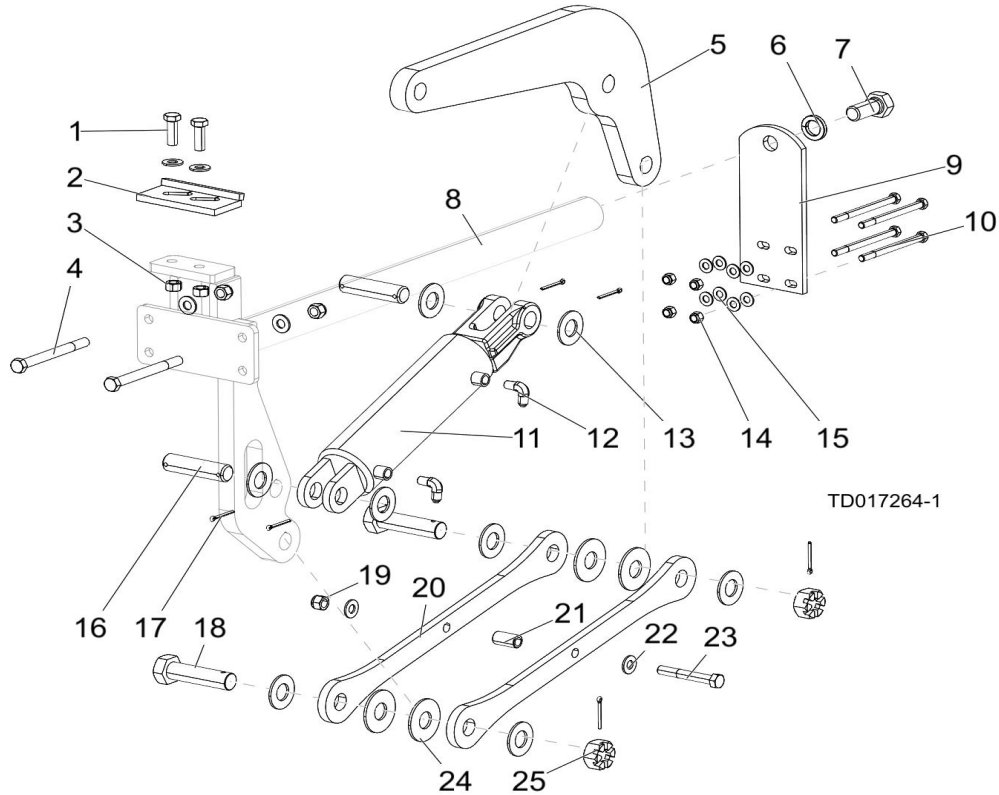

REF	PART #	DESCRIPTION	COMMENTS	QTY.
1	F05008-33	Bolt, 1/2-13x1 1/2 HH Gr5		2
2	W09404	Stop Weldment, Clamp		1
3	F05010-3	Nut, 1/2-13 Swaged Hex		2
4	F05008-28	Bolt, 1/2-13x5 1/2 Hex Head GR5 Zinc		2
5	017274	Plate, Clamp Pivot Arm		1
6	F05011-46	Washer, Split Lock 7/8 Zinc		1
7	F05014-2	Bolt, 7/8-14 X 2 Gr5 Zinc		1
8	017265	Slide Weldment, Hor. Clamp '99		1
9	015068	Plate, Clamp/Turner Mount		1
10	F05007-5	Bolt, 3/8-16x5 Hex Head GR2 Zinc		4
11	017275	Cylinder, 3x7 Hyd		1
12	015491	Fitting, 3/8JIC-1/4NPT 90 Elbow		2
13	F05011-28	Washer, 1 ID SAE Flat		8
14	F05010-10	Nut, 3/8-16 Hex Nyl Lock		4
15	F05011-3	Washer, 3/8 Flat SAE		8
16	S09251	Pin, 1x3.88		2
17	F05012-23	Pin, 3/16 x 1-1/2 Cotter		6
18	015072	Bolt, 1-14x3 3/4 Gr8		2
	017267	Assembly, Horizontal Clamp Link		1
19	F05010-8	Nut, 1/2-13 Nyl Hex Lock		3
20	017268	Plate, Clamp Link		2
21	130998	Sleeve, 1/2IDx3/4ODx1-3/8		1
22	F05011-2	Washer, 1/2 SAE Flat		6
23	F05008-61	Bolt, 1/2-13x3 1/2 Hex Head GR5 Zinc		1
24	015057	Washer, 1/8x2 1/2 Hardened		4
25	F05010-163	Nut, 1-14 Slotted Hex, Zinc		2

## 9.8 Hydraulic Log Clamp - clamp

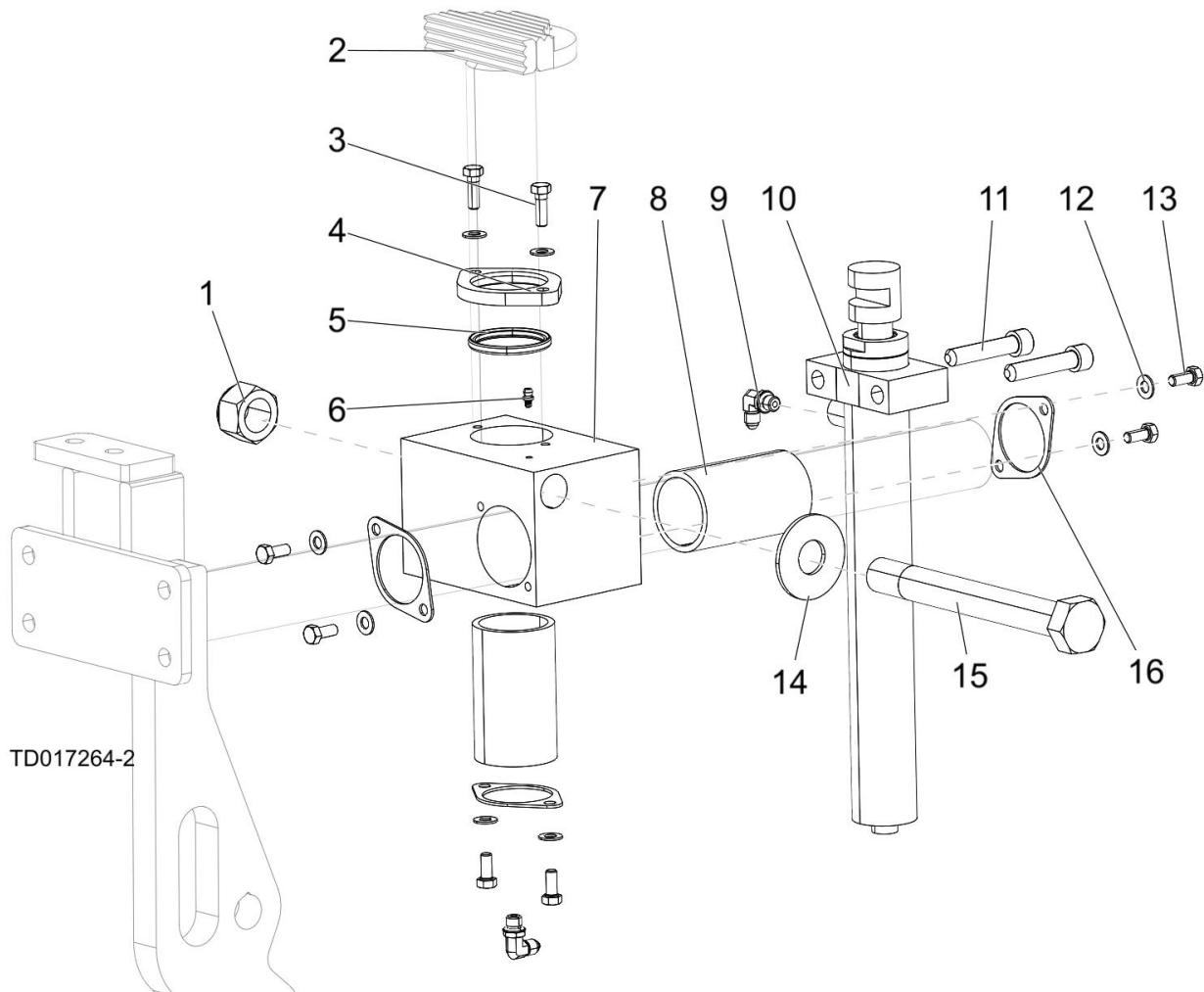

REF	PART #	DESCRIPTION	COMMENTS	QTY.
1	F05010-141	Nut, 1-14 Nylock		1
2	015043	Slide Weldment, Vertical Clamp		1
3	F05006-1	Bolt, 5/16-18x1 HH Gr2		2
4	017272	Flange, 3/8x3		1
5	017273	Wiper, Up/Down Rod		1
6	P04107	Fitting, 3/16x3/16 Straight Grease		1
7	017270	Block, Clamp		1
8	015088	Bushing, Clamp Slide		2
9	074543	Fitting, 4SAE-4JIC 90° Elbow		2
10	015050	Cylinder Weldment, Vert Clamp		1
11	F05008-39	Bolt, 1/2-13x2 1/2 SH BO		2
12	F05011-17	Washer, 5/16 SAE Flat		8
13	F05006-5	Bolt, 5/16-18x3/4 HH Gr2		6
14	015057	Washer, 1/8x2 1/2 Hardened		1
15	015049	Bolt, 1-14x8 1/2 Gr8		1
16	017242	Retainer, Clamp Bushing		3

## 9.9 Hydraulic Toe Board

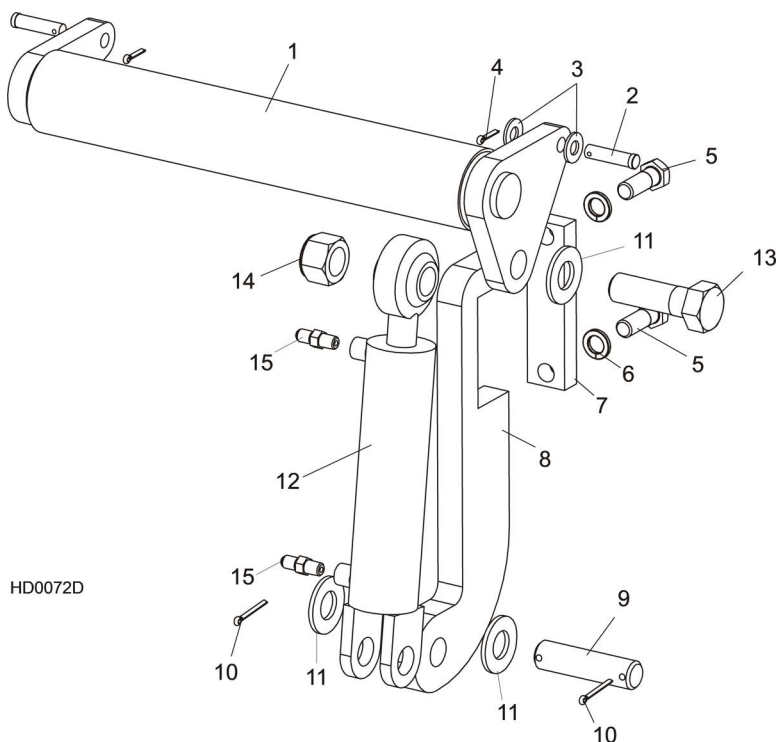

REF	PART #	DESCRIPTION	COMMENTS	QTY.
1	074842	Toe Board Assembly, Hydraulic		2
2	F05012-82	Pin, 1/2-1 3/4 Clevis		4
3	F05011-2	Washer, 1/2" SAE Flat		4
4	F05012-3	Pin, 1/8 x 3/4" Cotter		4
5	F05009-33	Bolt, 5/8-11 x 1 3/4" Hex Head		4
6	F05011-27	Washer, 5/8" Split Lock		4
7	S13023	Plate, Hydraulic ToeBoard Mount		2
8	S13022	Bracket, Hydraulic Toeboard Mount		2
9	S09251	Pin, Cylinder Mount		2
10	F05012-23	Pin, 3/16" x 1 1/2" Cotter		4
11	F05011-28	Washer, 1" SAE Flat		6
12	014482	Cylinder, 1 1/2" x 6" Hydraulic Toe board		2
	014547	Seal Kit, 1 1/2" x 6" Hydraulic Cylinder	Service Kit	1
13	F05009-51	Bolt, 1-8 x 3 1/4" Hex Head Grade 5		2
14	F05010-109	Nut, 1-8 Hex Nylon Lock		2
15	P09143	Fitting, 1/4" NPT x 1/4" JIC Male		4

### 9.10 Hydraulic Power Supply Strip

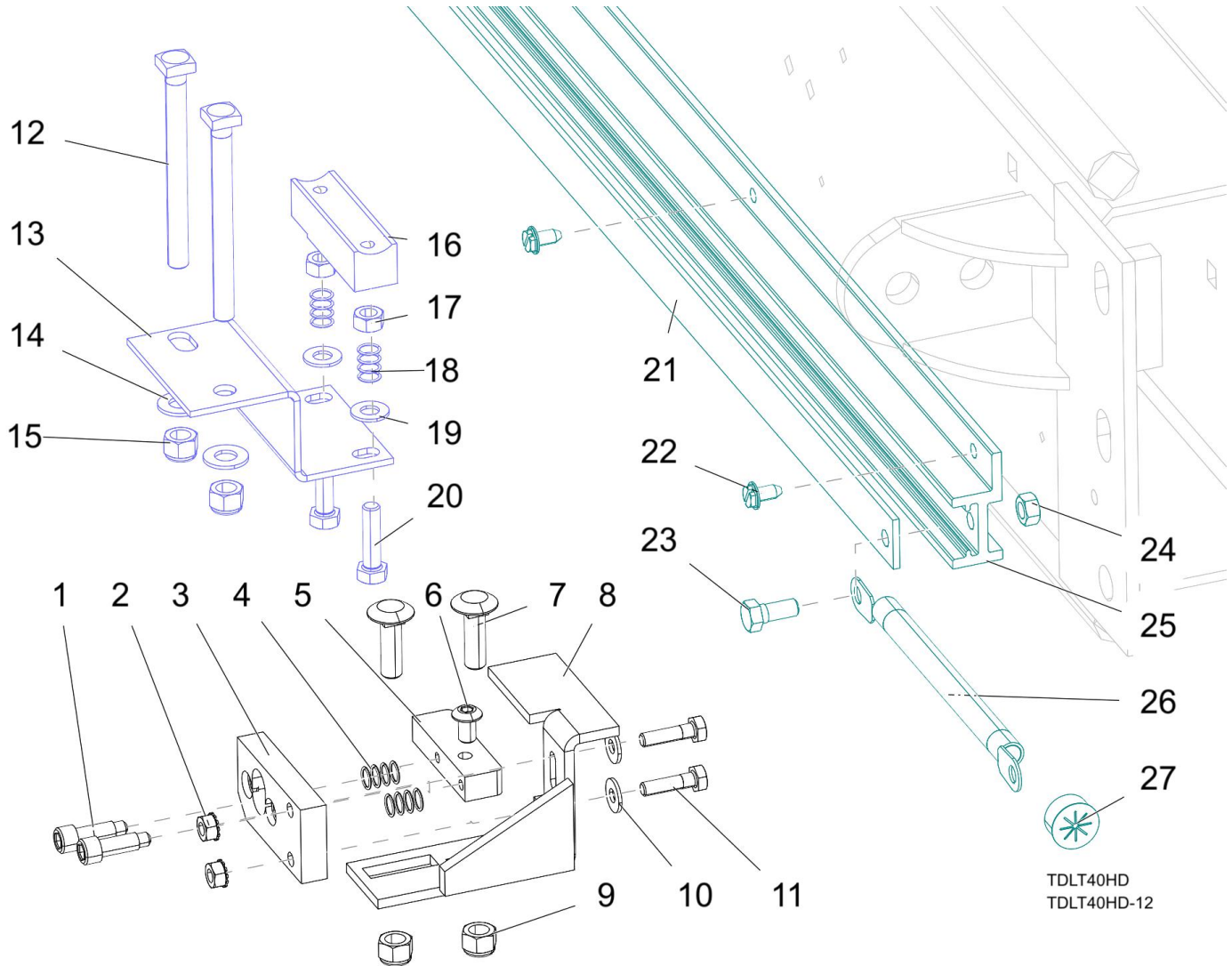

REF	PART #	DESCRIPTION	COMMENTS	QTY.
	017671	Contact Assy, Positive Hyd Power (97+)		1
	007716	Kit, Pos Contact 97 Replacement	Service kit containing items 1, 4, 5, and 6.	1
1	F05006-143	Bolt, 5/16x3/4 Shoulder (1/4-20 Thread)		2
2	F05010-9	Nut, 1/4-20 Keps		2
3	S10072	Plate, 1/2 Nyl Insulator Contact		1
4	P10077	Spring, .42x.59x.042 Comp		2
5	015253	Button, Hot Contact 1997		1
6	F05006-20	Screw, 5/16-18x1/2 SBH		1
7	F05007-11	Bolt, 3/8-16x1 1/4 Carriage		2
8	015324	Plate Wdmt, Hot Contact		1
9	F05010-10	Nut, 3/8-16 Hex Nyl Lock		2
10	F05011-11	Washer, 1/4 SAE Flat		2
11	F05005-38	Screw, 1/4-20x1 HHC		2
	016797	Contact Assy, Ground Hyd Power (97+)		1
12	F05007-175	Bolt, 3/8-16x4 Square Head		1

**9** **Bed Hydraulic System**  
Hydraulic Power Supply Strip

REF	PART #	DESCRIPTION	COMMENTS	QTY.
13	016792	Plate, HPS Ground Contact Mount		1
14	F05011-3	Washer, 3/8 Flat SAE		1
15	F05010-10	Nut, 3/8-16 Hex Nyl Lock		2
16	015264	Block, Exten. Hyd Ground Contact		1
17	F05010-17	Nut, 5/16-18 Hex		2
18	P10077	Spring, .42x.59x.042 Comp		2
19	F05011-17	Washer, 5/16 SAE Flat		1
20	F05006-93	Bolt, 5/16-18x1-1/4 HH FT Gr5		1
21	S10075	Strip, 1/8x1x69 13/16 CU		1
	A11977	Strip Assembly, 6 Ft. Contact		1
22	F05015-1	Bolt, 1/4-20x1/2 SI HH		8
23	F05006-45	Bolt, 5/16-18x3/4 HH Moulded Blk		1
24	F05010-86	Nut, 5/16-18 Nyl Lock Hex		1
25	P11976	Housing, Contact Strip		1
26	052161	Cable Assy, 1AWG Black x36		1
27	P04137	Grommet, 5/8 Wire		1

## SECTION 10 MISCELLANEOUS

### 10.1 Replacement Manuals



REF	DESCRIPTION (◆ Indicates Parts Available In Assemblies Only)	PART #	QTY.
<b>Wood-Mizer Product Information</b>			
1	ALL-PRODUCTS CATALOG	PS750	1
<b>Basic Sawmill Manuals</b>			
2	TRU-SHARP BLADE HANDBOOK	M600	1
3	WOOD-MIZER GENERAL INFORMATION	M601	1
4	LT40 SUPER OPERATOR'S MANUAL	M1647	1
5	LT40 SUPER PARTS MANUAL	M1646	1
<b>Power Option Manuals</b>			
6	E25 MOTOR OPTION MANUAL	M772	1
<b>Trailer Option Manuals</b>			
7	ELECTRIC BRAKE TRAILER OPTION	M796	1
8	SURGE BRAKE TRAILER OPTION	M794	1
<b>Miscellaneous Option Manuals</b>			
9	MANUAL WINCH OPTION MANUAL	M619-23	1
10	LOG TURNER OPTION MANUAL	M620	1
11	MANUAL TOE BOARD OPTION MANUAL	M627	1
12	SHINGLE/LAPSIDER OPTION MANUAL	M621	1
13	OPERATOR'S SEAT OPTION MANUAL	M613	1
14	RESAW ATTACHMENT OPTION MANUAL	M263	1
15	BED EXTENSION OPTION MANUAL	M294	1
16	MKII DEBARKER ATTACHMENT OPTION MANUAL	M546	1
17	ACCUSET 2 OPTION MANUAL	M1517	1
18	LASER SIGHT OPTION MANUAL	M679	1
19	AUTOCLUTCH OPTION MANUAL	M883	1
20	LUBE-MIZER OPTION MANUAL	M885	1
21	LATHE-MIZER OPTION MANUAL	M1337	1
<b>Electrical Diagrams</b>			
22	E25 ELECTRICAL INFORMATION	M863	1