

Wood-Mizer[®] Sawmill

Parts Manual

LT40 Super

rev. J7.03 - J7.19



Safety is our #1 concern! Read and understand all safety information and instructions before operating, setting up or maintaining this machine.

January 2010

Form #1646

California
Proposition 65 Warning



WARNING: Breathing gas/diesel engine exhaust exposes you to chemicals known to the State of California to cause cancer and birth defects or other reproductive harm.

- Always start and operate the engine in a well-ventilated area.
- If in an enclosed area, vent the exhaust to the outside.
- Do not modify or tamper with the exhaust system.
- Do not idle the engine except as necessary.

For more information go to **www.P65warnings.ca.gov**.



WARNING: Drilling, sawing, sanding or machining wood products can expose you to wood dust, a substance known to the State of California to cause cancer. Avoid inhaling wood dust or use a dust mask or other safeguards for personal protection.

For more information go to **www.P65Warnings.ca.gov/wood**.

©2019

Printed in the United States of America, all rights reserved. No part of this manual may be reproduced in any form by any photographic, electronic, mechanical or other means or used in any information storage and retrieval system without written permission from

Wood-Mizer
8180 West 10th Street
Indianapolis, Indiana 46214

Table of Contents

Section-Page

SECTION 1	GENERAL INFORMATION	1-1
1.1	How To Use The Parts List	1-1
1.2	Sample Assembly	1-1
SECTION 2	BLADE GUIDE ROLLERS & ARM	2-1
2.1	Blade Guide Assembly, Idle Side.....	2-1
2.2	Blade Guide Assembly, Drive Side.....	2-4
2.3	Blade Guide Arm Drive Assembly.....	2-7
2.4	Blade Guide Arm.....	2-9
SECTION 3	BLADE WHEELS & TENSIONER	3-1
3.1	Blade Drive Assembly.....	3-1
3.2	Idle Blade Wheel Assembly	3-3
3.3	Hydraulic Blade Tensioner Assembly.....	3-4
SECTION 4	SAW HEAD FRAME	4-1
4.1	Middle Throat Screw	4-1
4.2	Water Lube Solenoid Valve	4-2
4.3	Clutch/Brake Lever Assembly (D47/D51).....	4-3
4.4	Clutch/Brake Lever Assembly (E25)	4-5
4.5	Clutch Mount Assembly.....	4-7
4.6	Brake Assembly.....	4-8
4.7	Board Return Assembly	4-9
4.8	Water Lube Assembly (Gas Only)	4-11
	<i>LT40 Super Rev. J7.17+</i>	
4.9	Water Lube Assembly (Gas Only)	4-12
	<i>LT40 Super Prior to Rev. J7.17</i>	
4.10	Water Lube Assembly (Diesel & Electric Only).....	4-14
4.11	Blade Housing Covers	4-16
4.12	Saw Head Decals	4-18
	<i>After 11/15/10</i>	
4.13	Saw Head Decals	4-19
	<i>Prior to 11/15/10</i>	
4.14	Drive Belt Covers	4-20
4.15	Sawdust Chute	4-21
4.16	Debarker Wire Box/Hole Plugs.....	4-22
SECTION 5	ENGINE OPTIONS	5-1
	<i>LT30/LT40 Super</i>	
SECTION 6	OPTIONS & ADDITIONAL INCLUDED EQUIPMENT	6-1
	<i>LT30/LT40 Super</i>	

Table of Contents

Section-Page

SECTION 7	CONTROL & BATTERY BOXES	7-1
7.1	Control Assembly..... <i>LT40 Super Rev. J7.05+</i>	7-1
7.2	Control Assembly..... <i>LT40 Super Rev. J7.03 - J7.04</i>	7-3
7.3	Drum Switches.....	7-6
7.4	Circuit Breakers..... <i>LT40 Super Rev. J7.05+</i>	7-7
7.5	Circuit Breakers..... <i>LT40 Super Rev. J7.03 - J7.04</i>	7-8
7.6	Front Panel Assembly & Harnesses..... <i>LT40 Super Rev. J7.05+</i>	7-9
7.7	Front Panel Assembly & Harnesses..... <i>LT40 Super Rev. J7.03 - J7.04</i>	7-11
7.8	Battery Box Assembly.....	7-13
SECTION 8	UP/DOWN SYSTEM	8-1
8.1	Saw Head Mount.....	8-1
8.2	Blade Height & Quarter Scales.....	8-2
8.3	Up/Down Chain & Sprockets.....	8-4
8.4	Up/Down Motor Assembly.....	8-6
8.5	Up/Down Drive Assembly.....	8-7
SECTION 9	FEED SYSTEM & TRACK ROLLERS	9-1
9.1	Upper Track Rollers And Wipers.....	9-1
9.2	Power Feed Assembly.....	9-3
9.3	Feed Chain/Stop.....	9-5
9.4	Lower Track Rollers.....	9-6
SECTION 10	BED FRAME ASSEMBLY	10-1
10.1	Bed Rail Assembly, Front And Rear.....	10-1
10.2	Bed Rail Assembly, Middle Front.....	10-3
10.3	Bed Rail Assembly, Middle Rear.....	10-4
10.4	Leg Assembly (Stationary).....	10-6
10.5	Board Return Table Assembly.....	10-8
10.6	Pivot Bed Rail Assembly.....	10-9
10.7	Log Side Support Assembly (Manual).....	10-11
10.8	Safety Chain Assembly.....	10-13
10.9	Bed Frame Decals.....	10-14
10.10	Log Clamp.....	10-15
10.11	Log Loading Ramps.....	10-16
10.12	Board Outfeed Table (Optional).....	10-17
SECTION 11	BED HYDRAULIC LOG LOADER & TURNER (OPTIONAL)	11-1
11.1	Hydraulic Hoses.....	11-1

Table of Contents

Section-Page

11.2	Hydraulic Loader/Turner Control Box.....	11-2
	<i>HCA/HCA-A Rev. A1.00+</i>	
11.3	Hydraulic Loader Control Box.....	11-4
	<i>HLA/HLA-A Rev. A1.00 - A2.03</i>	
11.4	Hydraulic Power Supply Strip.....	11-6
11.5	Hydraulic Log Loader (Optional).....	11-8
	<i>HLA-A Rev. A3.00+</i>	
11.6	Hydraulic Log Turner (Optional).....	11-10
	<i>HLT-A Rev. A1.00+</i>	
11.7	Hydraulic Log Side Supports (Optional).....	11-12
11.8	Miscellaneous Loader & Turner Parts.....	11-14
SECTION 12	ACCESSORIES	12-16
	<i>LT30/LT40 Super</i>	
SECTION 13	TRAILERS	13-1
	<i>LT30/LT40 Super</i>	
SECTION 14	MISCELLANEOUS	14-1
14.1	Replacement Manuals.....	14-1
14.2	Tools.....	14-3
	INDEX	I

SECTION 1 GENERAL INFORMATION

1.1 How To Use The Parts List

- Use the table of contents or index to locate the assembly that contains the part you need.
- Go to the appropriate section and locate the part in the illustration.
- Use the number pointing to the part to locate the correct part number and description in the table.
- Parts shown indented under another part are included with that part.
- Parts marked with a diamond (◆) are only available in the assembly listed above the part.

See the sample table below. Sample Part #A01111 includes part F02222-2 and subassembly A03333. Subassembly A03333 includes part S04444-4 and subassembly K05555. The diamond (◆) indicates that S04444-4 is not available except in subassembly A03333. Subassembly K05555 includes parts M06666 and F07777-77. The diamond (◆) indicates M06666 is not available except in subassembly K05555.

1.2 Sample Assembly				
REF	DESCRIPTION (◆ Indicates Parts Available In Assemblies Only)	PART #	QTY.	
	SAMPLE ASSEMBLY, COMPLETE (INCLUDES ALL INDENTED PARTS BELOW)	A01111	1	
1	Sample Part	F02222-22	1	
	Sample Subassembly (Includes All Indented Parts Below)	A03333	1	
2	Sample Part (◆ Indicates Part Is Only Available With A03333)	S04444-4	1	◆
	Sample Subassembly (Includes All Indented Parts Below)	K05555	1	
3	Sample Part (◆ Indicates Part Is Only Available With K05555)	M06666	2	◆
4	Sample Part	F07777-77	1	

To Order Parts:

- From the continental U.S., call **1-800-525-8100** to order parts. Have your customer number, vehicle identification number, and part numbers ready when you call.
- From other international locations, contact the Wood-Mizer distributor in your area for parts.

SECTION 2 BLADE GUIDE ROLLERS & ARM

2.1 Blade Guide Assembly, Idle Side

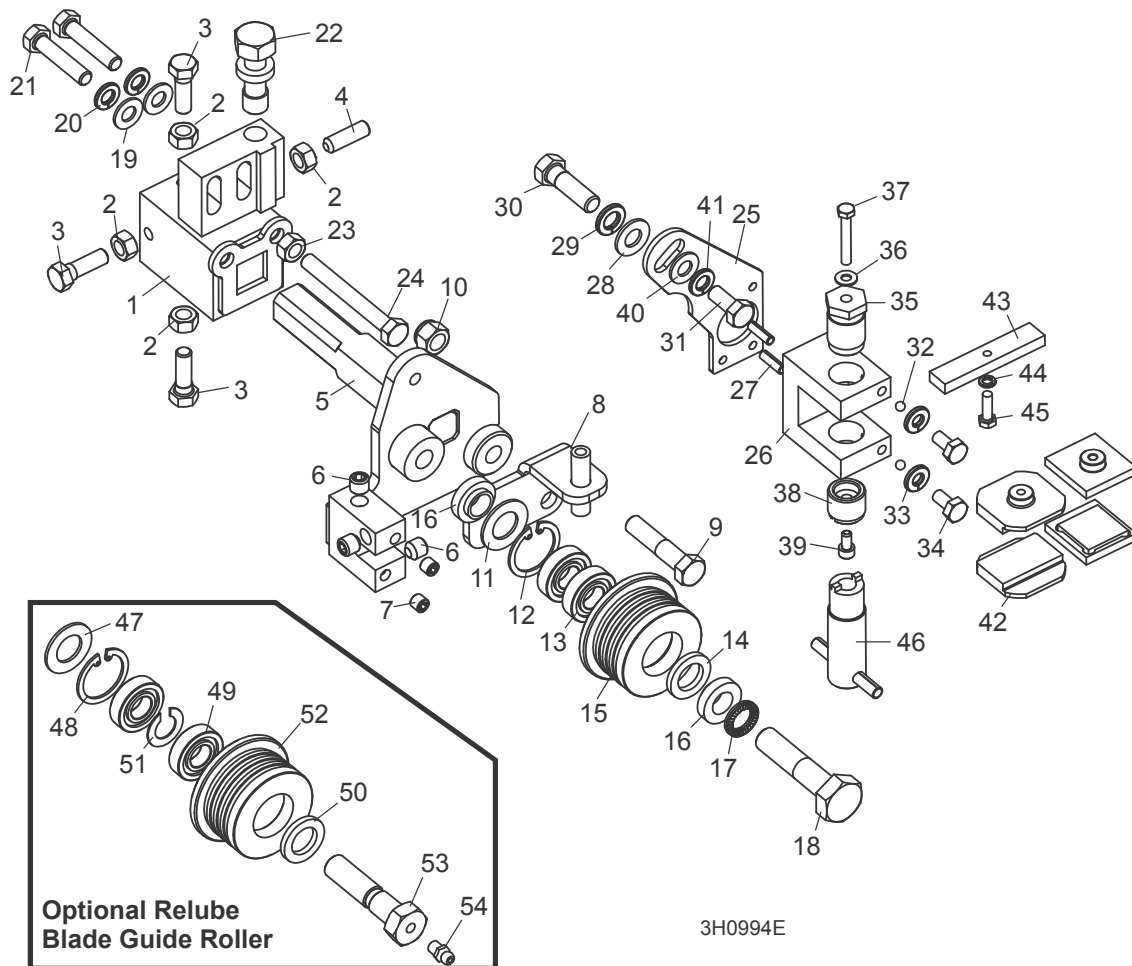

REF	DESCRIPTION (◆ Indicates Parts Available In Assemblies Only)	PART #	QTY.	
	GUIDE ASSEMBLY, IDLE SIDE BLADE ROLLER	003992	1	
	Block Assembly, Idle Side Blade Guide Mount	003920	1	
1	Block Weldment, Blade Guide Mount	003921	1	◆
2	Nut, 5/16-18 Hex	F05010-17	4	
3	Bolt, 5/16-18 x 1" Hex Head Stainless Steel	F05006-88	3	
4	Screw, 5/16-18 x 1" Socket Head Flat Point Stainless Steel Set	F05006-122	1	
5	Shaft Weldment, Idle Side Guide	003924	1	
6	Fitting, 1/8" NPT Socket Pipe Plug	P30127	3	
7	Fitting, 1/16" NPT Socket Pipe Plug	007734	2	
8	Bracket Weldment, Idle Side Water Lube	006322	1	

2

Blade Guide Rollers & Arm

Blade Guide Assembly, Idle Side

9	Bolt, 3/8-16x1 1/2 Hex Head Grade 5	F05007-78	1	
10	Nut, 3/8-16 Hex Nylon Lock	F05010-10	1	
	Roller Assembly, Blade Guide (standard for use with 1 1/4" & 1 1/2" blades)	A04925 ¹	1	
	Roller Assembly, Extended Blade Guide (optional for use with 1 1/2" blades)	014299 ¹	1	
	Bearing Kit, Blade Guide Rebuild	K07079	1	
11	Washer, 5/8" White Felt	P04252	1	
12	Ring, 1 1/8" Interior Retaining	F04254-1	1	
13	Bearing, R8-2RS Blade Guide	015975	2	◆
14	Washer, 5/8" Gray Felt	P06455	1	
	Screw, 1/4-28 x 1/4" Socket Head Cup Point Set Black Oxide	F05005-105	1	
	Instruction Sheet, Blade Guide Rebuild	057407-1507	1	
15	Roller, Flanged Blade Guide (1 1/4" & 1 1/2" blade)	S04250	1	◆
	Roller, Flanged Blade Guide (1 1/2" blade)	014298	1	◆
	Instruction Sheet, Blade Guide Roller Replacement	A04925-364	1	
16	Spacer, Blade Guide	S04253	2	
17	Washer, 1/2" Nord-Lock	F05011-125	1	
18	Bolt, 1/2-13 x 2 1/4" Hex Head Grade 5	F05008-10	1	
19	Washer, 5/16" SAE Flat	F05011-17	2	
20	Washer, 5/16" Split Lock	F05011-13	2	
21	Bolt, 5/16-18 x 1 1/2" Hex Head	F05006-76	2	
22	Bolt, Blade Guide Vertical Adjustment	035656	1	
23	Nut, 5/16-18 Hex	F05010-17	1	
24	Bolt, 5/16-18 x 2 3/4" Hex Head Full Thread	F05006-136	1	
	GUIDE KIT, HIGH-PERFORMANCE BLADE GUIDE (OPTIONAL)	006325 ²	1	
	Block Assembly, Idle Side Blade Guide	003928	1	
25	Plate, Block Tilt Adjustment	003915	1	
26	Block, Guide Block Mount	003909	1	
27	Pin, 3/16" x 5/8" Roll	F05012-22	2	
28	Washer, 3/8" SAE Flat	F05011-3	1	
29	Washer, 3/8" Split Lock	F05011-4	1	
30	Bolt, 3/8-16 x 1 1/4" Hex Head Grade 5	F05007-123	1	
31	Bolt, 5/16-18 x 3/4" Hex Head	F05006-102	1	
32	Ball, 3/16" Dia. Nylon	003914	2	
33	Washer, 1/4" Split Lock	F05011-14	2	
34	Bolt, 1/4-20 x 1/2" Hex Head	F05005-15	2	
35	Bolt, Blade Guide Block Mount	003994	1	
36	Washer, #10 Brass	042867	1	
37	Bolt, #10-32 x 1 1/4" Hex Head Stainless Steel	F05004-240	1	
38	Screw, Lower Block Adjustment	044057	1	
39	Screw, #10-32 x 3/8" Socket Head Stainless Steel	F05004-200	1	
40	Washer, 5/16" SAE Flat	F05011-17	1	
41	Washer, 5/16" Split Lock	F05011-13	1	

42	Block, Blade Guide Wear (Standard for 1 1/4" Blades)	052355 ³	2	
	Block, Blade Guide Wear (Optional for 1 1/2" Blades)	052309 ³	2	
	Block Assembly, 1" Sq. EZ-Glide Wear	036347 ³	2	
43	Block, Blade Guide Alignment	035799	1	
44	Washer, #10 Split Lock	F05011-20	1	
45	Screw, #10-32 x 5/8" Hex Head	F05004-152	1	
46	Adjustment Tool, Lower Guide Block	044064	1	
	Shim, .008" Blade Guide Block Spacer	035248	1	
Drive Side Blade Guide Parts (See Section 2.1)				
	ROLLER ASSEMBLY, BLADE GUIDE RELUBE (OPTIONAL FOR USE WITH 1 1/4" OR 1 1/2" BLADES)	016568 ¹	1	
	ROLLER ASSEMBLY, EXTENDED BLADE GUIDE RELUBE (OPTIONAL FOR USE WITH 1 1/2" BLADES)	057405 ¹	1	
	Bearing Kit, Relube Blade Guide Rebuild	057407	1	
47	Washer, 5/8" White Felt	P04252	1	
48	Ring, 1 1/8" Interior Retaining	F04254-1	1	
49	Bearing, R8-2RS Blade Guide	015975 ⁴	2	◆
50	Washer, 5/8" Gray Felt	P06455	1	
51	Spacer, Blade Guide Bearing	035411	1	
	Instruction Sheet, Blade Guide Rebuild	057407-1507	1	
52	Roller, Flanged Blade Guide (Relube 1 1/4" & 1 1/2" blade)	035426	1	◆
	Roller, Flanged Blade Guide (Relube 1 1/2" blade)	057402	1	◆
	Instruction Sheet, Blade Guide Roller Replacement	A04925-364	1	
53	BOLT, BLADE GUIDE ROLLER (RELUBE ONLY)	036161	1	
54	FITTING, 1/4-28 GREASE (RELUBE ONLY)	P05060	1	

¹ The sawmill is equipped standard with non-greasable blade guide rollers that can be used with the standard 1 1/4" blade or 1 1/2" blades. Optional extended blade guide rollers are available for use with 1 1/2" blades. The extended rollers may provide more stability during difficult sawing, but will reduce the total amount of times the blade can be reused after sharpening. Use kit 006382 to convert the rollers and guide blocks for both blade guides for 1 1/2" blades. Optional relube versions of each roller configuration are also available.

² High-Performance Blade Guide Kit requires LMS blade lube system. Use kit 006325 to upgrade both drive and idle side blade guides to High-Performance. If sawmill not already equipped with LMS, add kit .

³ 052355 blocks for use with 1 1/4" blade provided as standard equipment. 052309 blocks available for optional use with 1 1/2" blades. Use kit 006382 to convert the rollers and guide blocks for both blade guides for 1 1/2" blades. EZ-Glide blocks 036347 are available for customers who prefer this block.

⁴ Bearing must be modified for use with relube roller assemblies. Remove one seal from each bearing, place open sides facing each other and place spacer 035411 between bearings.

2 Blade Guide Rollers & Arm

Blade Guide Assembly, Drive Side

2.2 Blade Guide Assembly, Drive Side

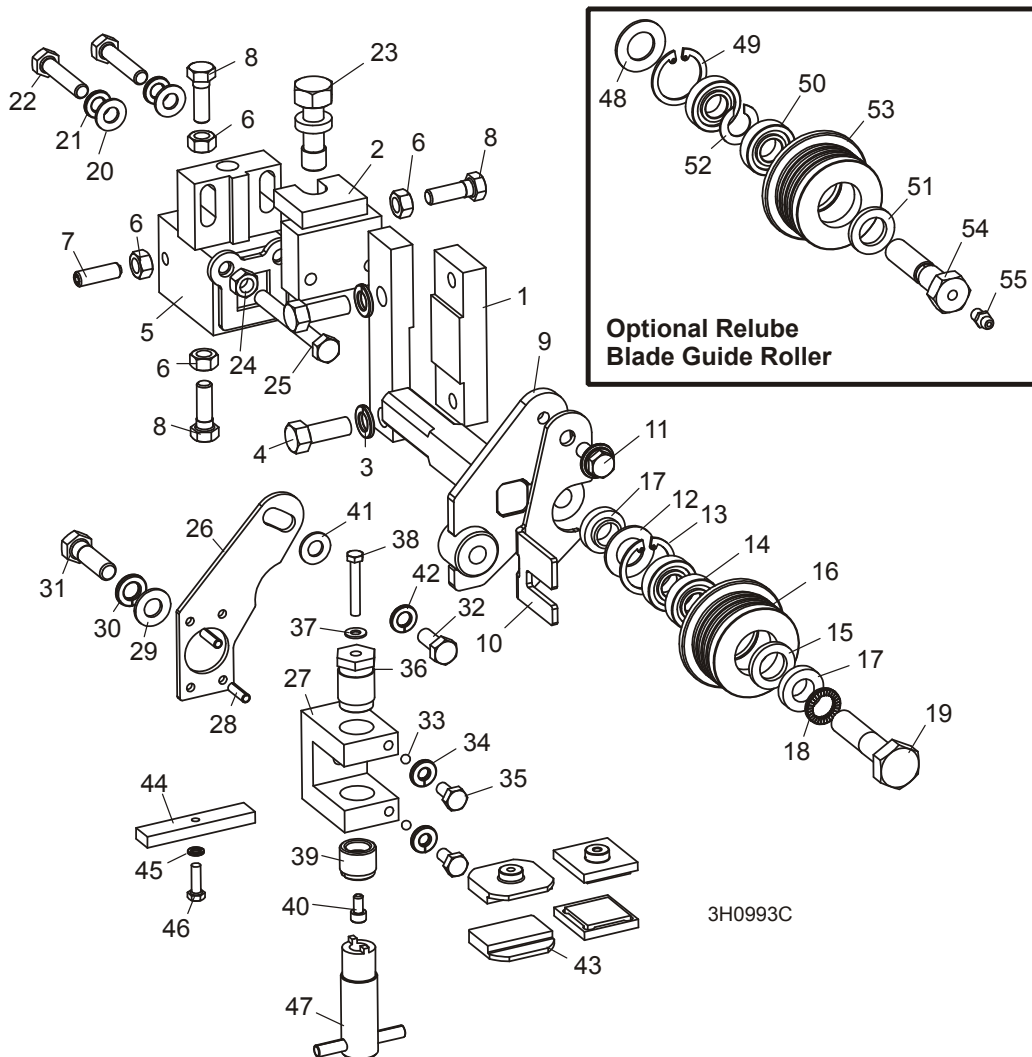

3H0993C

REF	DESCRIPTION (◆ Indicates Parts Available In Assemblies Only)	PART #	QTY.
1	BLOCK, BOLT ON BLADE GUIDE MOUNT	016548	1
2	BRACKET WELDMENT, INNER BLADE GUIDE MOUNT	003964	1
3	WASHER, 3/8" SPLIT LOCK	F05011-4	2
4	BOLT, 3/8-16 X 1" HEX HEAD	F05007-7	2
	GUIDE ASSEMBLY, DRIVE SIDE BLADE ROLLER	003905	1
	Block Assembly, Blade Guide Mount	003910	1
5	Block Weldment, Blade Guide Mount	003911	1
6	Nut, 5/16-18 Hex	F05010-17	4
7	Screw, 5/16-18 x 1" Socket Head Flat Point Stainless Steel Set	F05006-122	1
8	Bolt, 5/16-18 x 1" Hex Head Stainless Steel	F05006-88	3
9	Shaft Weldment, Drive Side Guide	003913	1

Blade Guide Rollers & Arm

Blade Guide Assembly, Drive Side

2

10	Plate, Blade Guide Deflector	003916	1	
11	Bolt, 5/16-18 x 3/4" Hex Head w/Flat & Lock Washer	F05006-101	1	
	Roller Assembly, Blade Guide (standard for use with 1 1/4" & 1 1/2" blades)	A04925 ¹	1	
	Roller Assembly, Extended Blade Guide (optional for use with 1 1/2" blades)	014299 ¹	1	
	Bearing Kit, Blade Guide Rebuild	K07079	1	
12	Washer, 5/8" White Felt	P04252	1	
13	Ring, 1 1/8" Interior Retaining	F04254-1	1	
14	Bearing, R8-2RS Blade Guide	015975	2	◆
15	Washer, 5/8" Gray Felt	P06455	1	
	Screw, 1/4-28 x 1/4" Socket Head Cup Point Set Black Oxide	F05005-105	1	
	Instruction Sheet, Blade Guide Rebuild	057407-1507	1	
16	Roller, Flanged Blade Guide (1 1/4" & 1 1/2" blade)	S04250	1	◆
	Roller, Flanged Blade Guide (1 1/2" blade)	014298	1	◆
	Instruction Sheet, Blade Guide Roller Replacement	A04925-364	1	
17	Spacer, Blade Guide	S04253	2	
18	Washer, 1/2" Nord-Lock	F05011-125	1	
19	Bolt, 1/2-13 x 2 1/4" Hex Head Grade 5	F05008-10	1	
20	Washer, 5/16" SAE Flat	F05011-17	2	
21	Washer, 5/16" Split Lock	F05011-13	2	
22	Bolt, 5/16-18 x 1 1/4" Hex Head	F05006-93	2	
23	Bolt, Blade Guide Vertical Adjustment	035656	1	
24	Nut, 5/16-18 Hex	F05010-17	1	
25	Bolt, 5/16-18 x 2 3/4" Hex Head Full Thread	F05006-136	1	
	GUIDE KIT, HIGH-PERFORMANCE BLADE GUIDE (OPTIONAL)	006325 ²	1	
	Block Assembly, Drive Side Blade Guide	003927	1	
26	Plate, Block Tilt Adjustment	003915	1	
27	Block, Guide Block Mount	003909	1	
28	Pin, 3/16" x 5/8" Roll	F05012-22	2	
29	Washer, 3/8" SAE Flat	F05011-3	1	
30	Washer, 3/8" Split Lock	F05011-4	1	
31	Bolt, 3/8-16 x 1 1/4" Hex Head Grade 5	F05007-123	1	
32	Bolt, 5/16-18 x 3/4" Hex Head	F05006-102	1	
33	Ball, 3/16" Dia. Nylon	003914	2	
34	Washer, 1/4" Split Lock	F05011-14	2	
35	Bolt, 1/4-20 x 1/2" Hex Head	F05005-15	2	
36	Bolt, Blade Guide Block Mount	003994	1	
37	Washer, #10 Brass	042867	1	
38	Bolt, #10-32 x 1 1/4" Hex Head Stainless Steel	F05004-240	1	
39	Screw, Lower Block Adjustment	044057	1	
40	Screw, #10-32 x 3/8" Socket Head Stainless Steel	F05004-200	1	
41	Washer, 5/16" SAE Flat	F05011-17	1	
42	Washer, 5/16" Split Lock	F05011-13	1	

2

Blade Guide Rollers & Arm

Blade Guide Assembly, Drive Side

43	Block, Blade Guide Wear (Standard for 1 1/4" Blades)	052355 ³	2	
	Block, Blade Guide Wear (Optional for 1 1/2" Blades)	052309 ³	2	
	Block Assembly, 1" Sq. EZ-Glide Wear	036347 ³	2	
44	Block, Blade Guide Alignment	035799	1	
45	Washer, #10 Split Lock	F05011-20	1	
46	Screw, #10-32 x 5/8" Hex Head	F05004-152	1	
47	Adjustment Tool, Lower Guide Block	044064	1	
	Shim, .008" Blade Guide Block Spacer	035248	1	
Idle Side Blade Guide Parts (See Section 2.1)				
	ROLLER ASSEMBLY, BLADE GUIDE RELUBE (OPTIONAL FOR USE WITH 1 1/4" OR 1 1/2" BLADES)	016568 ¹	1	
	ROLLER ASSEMBLY, EXTENDED BLADE GUIDE RELUBE (OPTIONAL FOR USE WITH 1 1/2" BLADES)	057405 ¹	1	
	Bearing Kit, Relube Blade Guide Rebuild	057407	1	
48	Washer, 5/8" White Felt	P04252	1	
49	Ring, 1 1/8" Interior Retaining	F04254-1	1	
50	Bearing, R8-2RS Blade Guide	015975 ⁴	2	◆
51	Washer, 5/8" Gray Felt	P06455	1	
52	Spacer, Blade Guide Bearing	035411	1	
	Instruction Sheet, Blade Guide Rebuild	057407-1507	1	
53	Roller, Flanged Blade Guide (Relube 1 1/4" & 1 1/2" blade)	035426	1	◆
	Roller, Flanged Blade Guide (Relube 1 1/2" blade)	057402	1	◆
	Instruction Sheet, Blade Guide Roller Replacement	A04925-364	1	
54	BOLT, BLADE GUIDE ROLLER (RELUBE ONLY)	036161	1	
55	FITTING, 1/4-28 GREASE (RELUBE ONLY)	P05060	1	

¹ The sawmill is equipped standard with non-greasable blade guide rollers that can be used with the standard 1 1/4" blade or 1 1/2" blades. Optional extended blade guide rollers are available for use with 1 1/2" blades. The extended rollers may provide more stability during difficult sawing, but will reduce the total amount of times the blade can be reused after sharpening. Use kit 006382 to convert the rollers and guide blocks for both blade guides for 1 1/2" blades. Optional relube versions of each roller configuration are also available.

² High-Performance Blade Guide Kit requires LMS blade lube system. Use kit 006325 to upgrade both drive and idle side blade guides to High-Performance. If sawmill not already equipped with LMS, add kit .

³ 052355 blocks for use with 1 1/4" blade provided as standard equipment. 052309 blocks available for optional use with 1 1/2" blades. Use kit 006382 to convert the rollers and guide blocks for both blade guides for 1 1/2" blades. EZ-Glide blocks 036347 are available for customers who prefer this block.

⁴ Bearing must be modified for use with relube roller assemblies. Remove one seal from each bearing, place open sides facing each other and place spacer 035411 between bearings.

2.3 Blade Guide Arm Drive Assembly

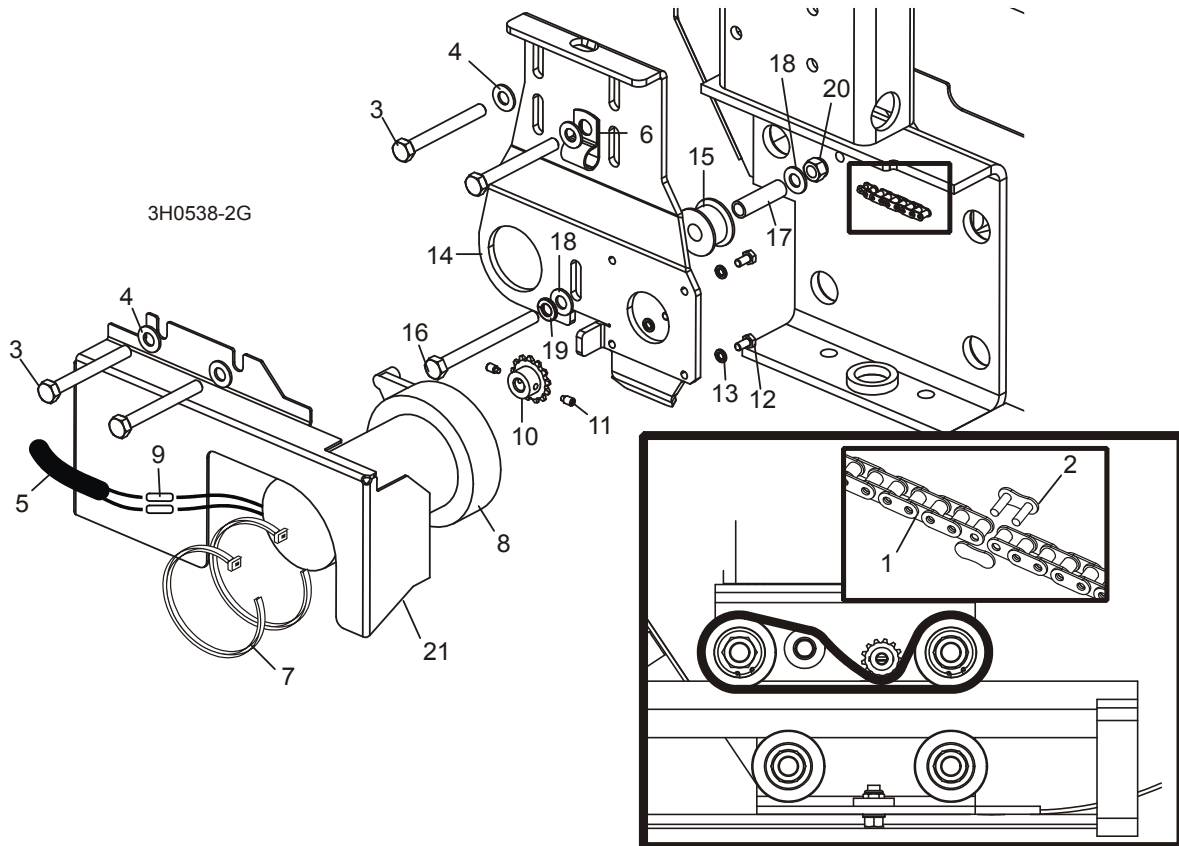

REF	DESCRIPTION (◆ Indicates Parts Available In Assemblies Only)	PART #	QTY.
1	CHAIN, #25 X 20 1/4"	P09984	1
2	LINK, #25 MASTER	P09983	1
3	BOLT, 5/16-18 X 2 3/4" HEX HEAD GRADE 5	F05006-28	4
4	WASHER, 5/16" SAE FLAT	F05011-17	4
5	TUBE, 3/8" X 1/2" NEOPRENE	R01897	2.5ft
6	CLAMP, 1/2" COATED EMT	P07584	2
7	WRAP, 1/4" X 6" TIE	F05089-1	2
	DRIVE ASSEMBLY, BLADE GUIDE ARM	015989	1
	Motor Assembly, Blade Guide Arm Replacement	079215 ¹	1
8	Motor, Current Applications 1/30HP 12VDC Gear	079214	1
	Gear Kit, Motor Replacement (Current Application)	061232	1
	Brush Kit, Gear Motor Replacement (Current Application)	061234	1
	Shaft Kit, Gear Motor Replacement (Current Application)	061233	1
9	Connector, 14 Gauge Butt	F04875-1	2
10	Sprocket, Gear Motor #25 14-Tooth	P09970 ²	1
11	Screw, #10-24 x 1/4" Full Dog Point Socket Set	F05004-274	2
12	Screw, #10-32 x 1/2" Hex Head	F05004-60	4

2

Blade Guide Rollers & Arm

Blade Guide Arm Drive Assembly

13	Washer, #10 Split Lock	F05011-20	4	
	Instruction Sheet, Blade Guide Arm Motor	A10365-296	1	
14	Bracket, Blade Guide Arm Motor Mount	015939	1	
15	Roller, Blade Guide Arm Chain Idler	S09999	1	
16	Bolt, 5/16-18 X 3 1/2" Hex Head Full Thread	F05006-3	1	
17	Spacer, 5/16" I.D. X 1 1/2"	S09996	1	
18	Washer, 5/16" SAE Flat	F05011-17	2	
19	Washer, 5/16" Split Lock	F05011-13	1	
20	Nut, 5/16-18 Hex Nylon Lock	F05010-58	1	
21	COVER, BLADE GUIDE ARM MOTOR	S11617	1	
	GUARD, BLADE GUIDE ARM (G.S. ONLY)	S12029	1	

¹ Replaced A10353 Motor Assembly including P09698-1 1/30 HP 62RPM 12VDC 53:1 Gear Motor with P12756 End Housing, P12569 Gear Kit, P12800 Brush Kit and 009695 Shaft Kit (LT40 Super Rev. J7.19).

² Sprocket modified 6/11 with threaded holes to accept included set screws (replace 1/8" x 3/4" roll pin F05012-6).

2.4 Blade Guide Arm

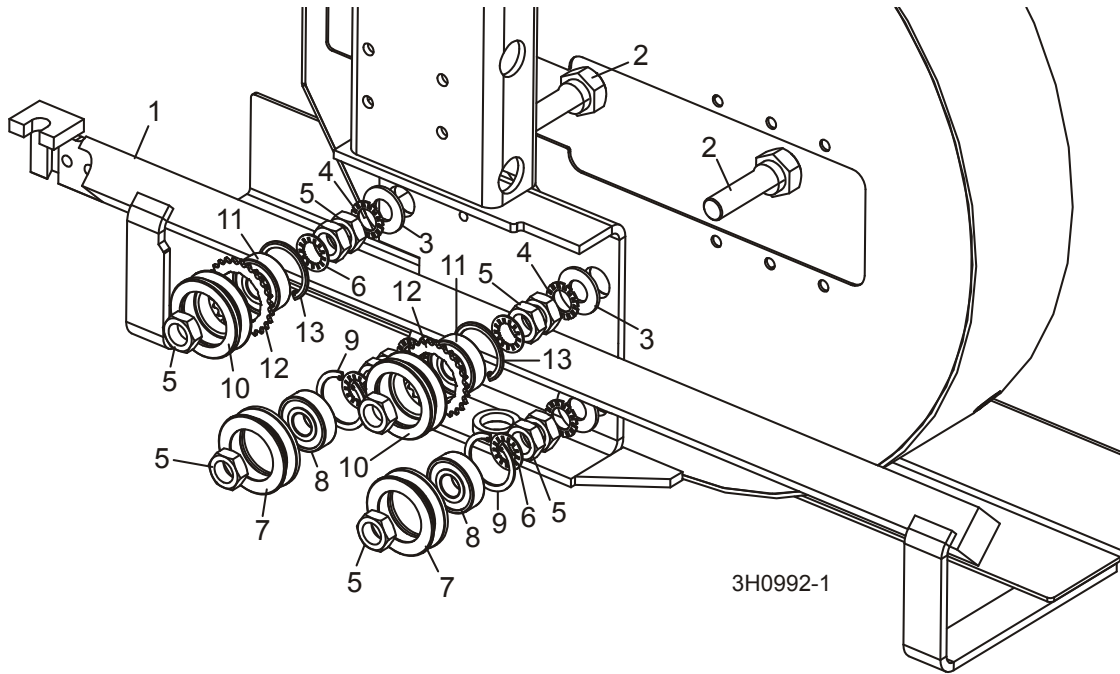

REF	DESCRIPTION (◆ Indicates Parts Available In Assemblies Only)	PART #	QTY.	
1	BLADE GUIDE ARM WELDMENT	003972	1	
	BLADE GUIDE ARM WELDMENT (WIDE HEAD ONLY)	007040	1	
2	BOLT, BLADE GUIDE ARM ROLLER CAM	W09067	4	
3	WASHER, 5/8" SAE FLAT	F05011-5	4	
4	WASHER, 5/8" EXTERNAL STAR	F05011-26	4	
5	NUT, 5/8-18 HEX JAM	F05010-11	12	
6	WASHER, 5/8" INTERNAL STAR	F05011-25	8	
	ROLLER ASSEMBLY, BLADE GUIDE ARM WITH BEARING	A09059	2	
7	Roller, Blade Guide Arm V-Groove	S07989	1	◆
8	Bearing, 6203-2NSL 5/8" I.D.	P06030-1	1	◆
9	Ring, 1.575" ID Beveled 5002-156 Retaining	F04254-8	1	
	ROLLER ASSEMBLY, BLADE GUIDE ARM WITH BEARING AND SPROCKET	A09932	2	
10	Roller, Blade Guide Arm Drive	S09930	1	◆
11	Bearing, 6203-2NSL 5/8" I.D.	P06030-1	1	◆
12	Sprocket, #25 26-Tooth	S09931	1	◆
13	Ring, 1.575" ID Beveled 5002-156 Retaining	F04254-8	1	

SECTION 3 BLADE WHEELS & TENSIONER

3.1 Blade Drive Assembly

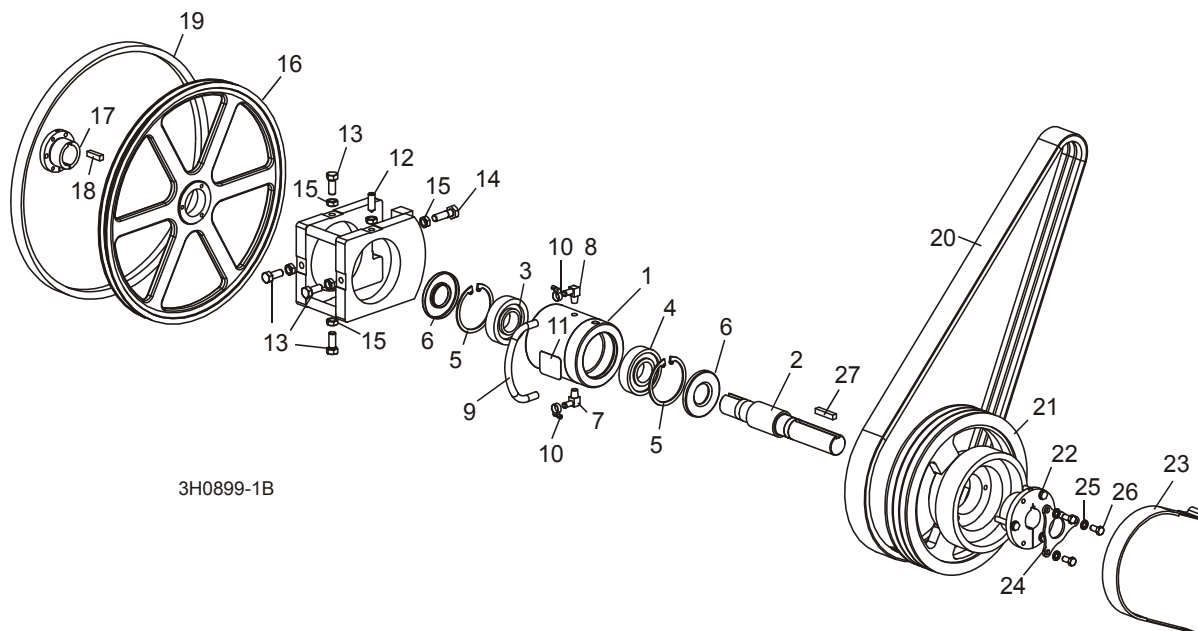

3H0899-1B

REF	DESCRIPTION (◆ Indicates Parts Available In Assemblies Only)	PART #	QTY.	
	BEARING ASSEMBLY, BLADE WHEEL DRIVE	016393	1	
	Bearing Assembly, Cylindrical Drive	016392	1	◆
1	Housing, Blade Wheel Drive Bearing	016391	1	◆
2	Shaft, Blade Wheel Drive	014005	1	◆
3	Bearing, Blade Wheel Drive #MU1308TV	P10205	1	
4	Bearing, Blade Wheel Drive #6308 C3 Open	016055	1	
5	Ring, 90mm Interior Retaining #I17	F04254-17	2	
6	Seal, Drive Bearing #CR15890	P10206	2	
7	Fitting, 1/4" NPT x 3/8" Hose Barb Elbow	016330	1	
8	Fitting, 1/4" NPT x 3/8" Hose Barb Vented Elbow	016331	1	
9	Hose, Oil Level Viewer	016394	1	
10	Clamp, 7/32-5/8" Hose	P649	2	
11	Decal, Oil Level Gauge	017470	1	
	Instruction Sheet, Drive Bearing Replacement	016393-555	1	
12	SCREW, 1/2-20 X 1 1/2" CONE POINT SET	F05004-170	1	
13	BOLT, 1/2-20 X 1 1/4" HEX HEAD GRADE 5	F05008-108	4	
14	BOLT, 1/2-20 X 1 3/4" HEX HEAD GRADE 5	F05008-49	1	
15	NUT, 1/2-20 HEX JAM	F05010-16	6	
	WHEEL KIT, DRIVE SIDE BLADE	014562	1	

Blade Wheel & Tensioner

Blade Drive Assembly

3

16	Wheel, Drive Side Blade	016284	1	◆
17	Bushing, Modified 1 9/16" SD	016270	1	
18	Key, 3/8" x 3/8" x 1 5/8"	S12892	1	
	Instruction Sheet, Drive Side Blade Wheel Replacement	K12897-488	1	
19	BELT, BLADE WHEEL B57	P04185	1	
20	BELT, DRIVE (SEE ENGINE OPTION FOR PART #)			
21	SHEAVE, 5V12.5X3 BRAKE COMBO	016531	1	
22	BUSHING, SF X 1 9/16"	016532	1	
23	STRAP, METAL-BACKED BRAKE	014391	1	
24	PLATE, BUSHING KEY RETAINER	017953	1	
25	WASHER, 3/8" SPLIT LOCK	F05011-4	3	
26	BOLT, 3/8-16 X 3/4" HEX HEAD	F05007-27	3	
27	KEY, 3/8" X 3/8" X 1 7/8"	014693	1	

3 Blade Wheels & Tensioner

Idle Blade Wheel Assembly

3.2 Idle Blade Wheel Assembly

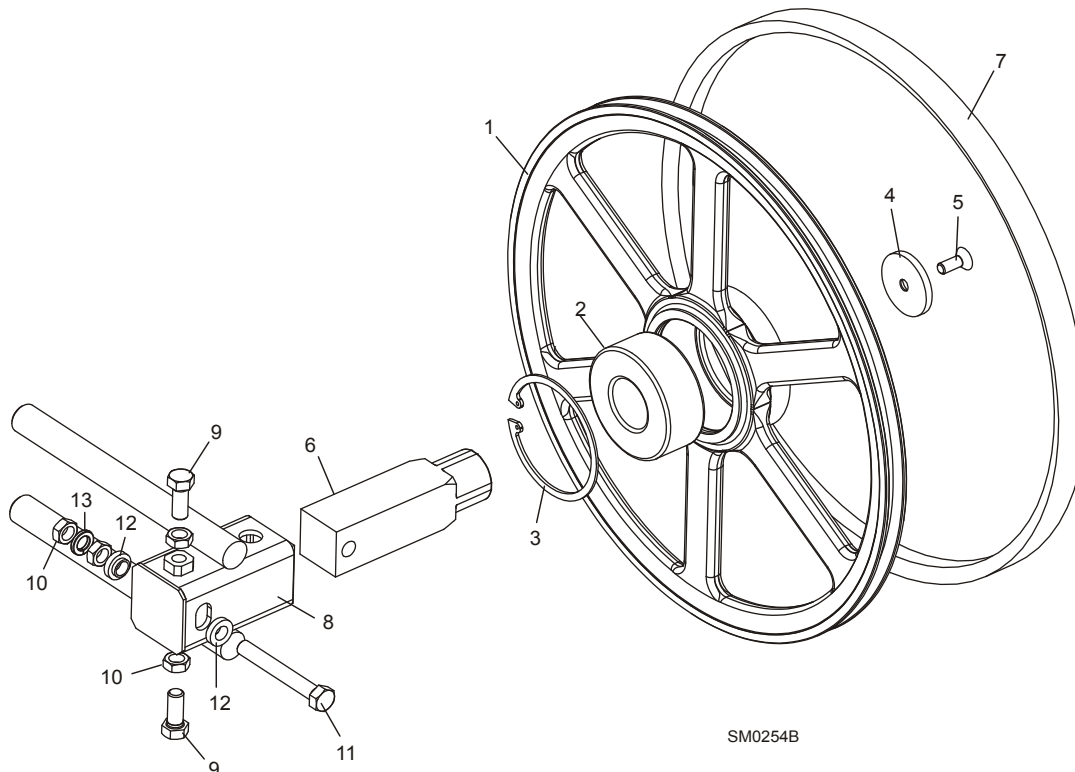

REF	DESCRIPTION (◆ Indicates Parts Available In Assemblies Only)	PART #	QTY.	
	WHEEL ASSEMBLY, IDLE SIDE BLADE	016120	1	
1	Wheel, Idle Side Blade	016013	1	◆
2	Bearing, Idle Side Blade Wheel #5309-2RS, C3, SRI-2 Grease	016014	1	
3	Ring, 100mm Internal Retaining Beveled	F04254-28	1	
	SHAFT KIT, IDLE BLADE WHEEL	016441	1	
4	Washer, 13/32" I.D. x 2 3/16 O.D. x 1/4"	016397	1	
5	Bolt, 3/8-16 x 1" Flat Head Socket	F05007-64	1	
6	Shaft, Idle Side Blade Wheel	016398	1	
7	BELT, BLADE WHEEL B57	P04185	1	
8	HOUSING, IDLE BLADE WHEEL SHAFT	016103	1	
9	BOLT, 1/2-20 X 1 1/2" HEX HEAD GRADE 5	F05008-53	2	
10	NUT, 1/2-20 HEX JAM	F05010-16	4	
11	BOLT, 1/2-20 X 3 3/4" HEX HEAD FULL THREAD GRADE 2	F05008-111	1	
12	SPACER, 1/2" I.D. FLANGED	S04253	2	
13	WASHER, 1/2" SPLIT LOCK	F05011-9	1	

3.3 Hydraulic Blade Tensioner Assembly

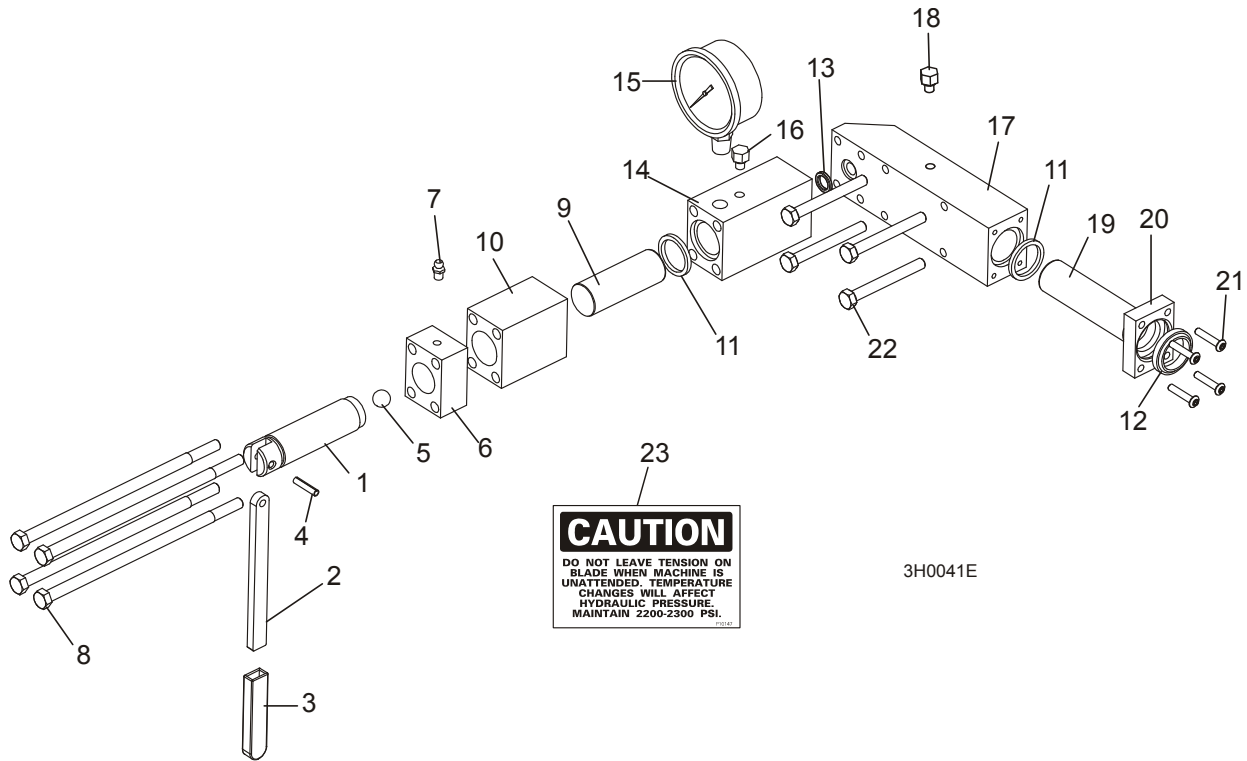

REF	DESCRIPTION (◆ Indicates Parts Available In Assemblies Only)	PART #	QTY.	
	HYDRAULIC BLADE TENSIONER ASSEMBLY	A10136	1	
	Handle Assembly, Hydraulic Blade Tensioner Screw	A12294	1	
1	Screw, Hydraulic Blade Tensioner	S10056	1	◆
2	Handle, Hydraulic Tensioner Screw	S08174	1	
3	Sleeve, Plastic Handle	P08072	1	
4	Pin, 3/16" x 7/8" Roll	F05012-19	1	
5	Ball, 1/2" Steel	P02720	1	
6	Block, Threaded Tensioner End	S10062	1	◆
7	Fitting, 1/4-28 Grease	P05060	1	
	Instruction Sheet, Tensioner Screw	A12294-518	1	
8	Bolt, 5/16-18 X 7 1/2" Hex Head Grade 5	F05006-43	4	
9	Piston, Hydraulic Tensioner Front 2 3/4" Long	S10060	1	
10	Block, Piston Guide	S10061	1	
	Seal Kit, Hydraulic Tensioner	003224	1	
5	Ball, 1/2" Steel	P02720	1	
11	Seal, 1" Diameter	P10051	2	
12	Wiper, 1" Diameter	P10053	1	
13	Ring, 5/8" X 3/32" Square "O"	P10377	1	

3**Blade Wheels & Tensioner**
Hydraulic Blade Tensioner Assembly

14	Block, Hydraulic Tensioner Gauge Mounting	S10140	1	
15	Gauge, 3000 P.S.I. Hydraulic	P10052	1	
16	Plug, Hydraulic Tensioner Fill	P10065	1	
	Block Assembly, Rear Tensioner Piston	016329	1	
17	Block, Rear Tensioner Piston	S10142	1	◆
18	Plug, Hydraulic Tensioner Fill	P10065	1	
19	Piston, Hydraulic Tensioner Rear 3 5/8" Long	S10059	1	
20	Block, Rear Piston End	S10089	1	
21	Bolt, #10-24 X 1" Socket Button Head	F05004-43	4	
22	Bolt, 5/16-18 X 2 3/4" Hex Head Grade 5	F05006-28	4	
23	Decal, Hydraulic Tension Caution	P10147	1	
	Instruction Sheet, Hydraulic Tensioner Installation	A10136-272	1	

SECTION 4 SAW HEAD FRAME

4.1 Middle Throat Screw

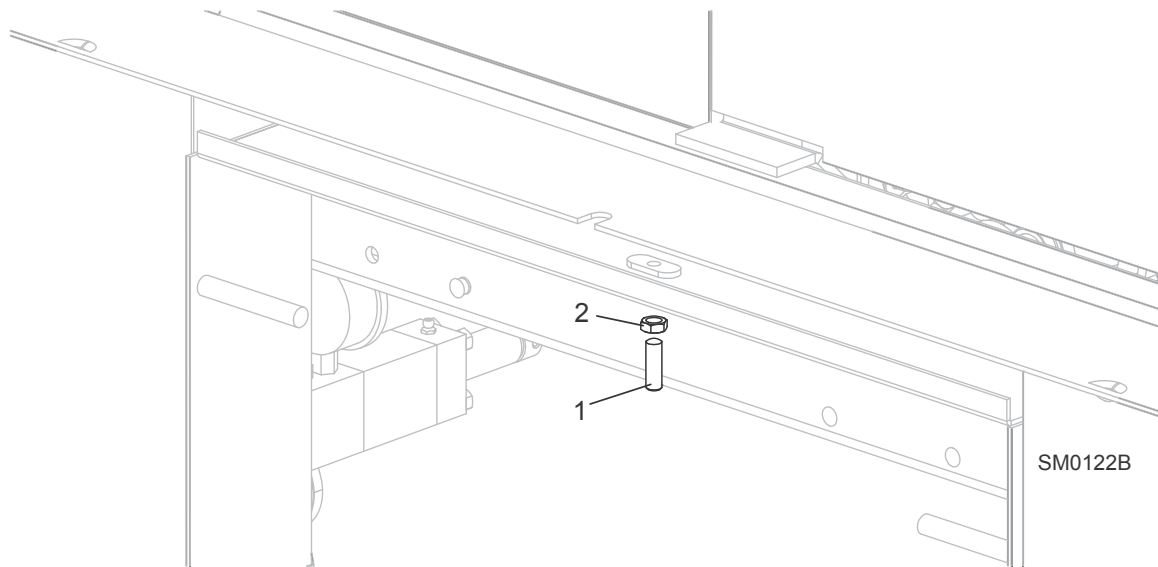

REF	DESCRIPTION (◆ Indicates Parts Available In Assemblies Only)	PART #	QTY.	
1	SCREW, 3/8-16 X 1 1/4" OVAL POINT SOCKET SET	F05007-18	1	
2	NUT, 3/8-16 HEX JAM	F05010-29	1	

4 Saw Head

Water Lube Solenoid Valve

4.2 Water Lube Solenoid Valve

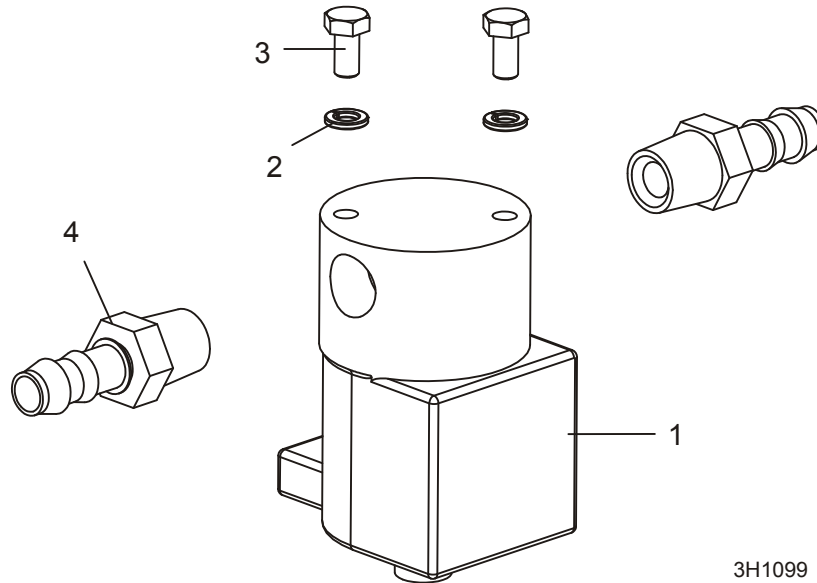

REF	DESCRIPTION (◆ Indicates Parts Available In Assemblies Only)	PART #	QTY.	
	VALVE KIT, WATER LUBE SOLENOID	016280 ¹	1	
1	Valve, Water Lube Solenoid	016140	1	◆
2	Bolt, #10-32 x 1/2" Hex Head	F05004-60	2	
3	Washer, #10 Split Lock	F05011-20	2	
4	Fitting, 1/4" Male NPT 3/8" Hose Barb	P04682	2	
	Diode Assembly, Inductive Kick Protection	024123	1	
	Connector, T-Tap 14-18 AWG Female	F04875-13	2	
	Terminal, 1/4 14-16 Ga Quick Female FI	F05708-3	2	

¹ Hose barb fitting (P04682), diode assembly (024123), connector (F04875-13) and terminal (F05708-3) added to solenoid valve kit (016280) on models with LT40 Super Rev. J7.07 (5/11).

4.3 Clutch/Brake Lever Assembly (D47/D51)

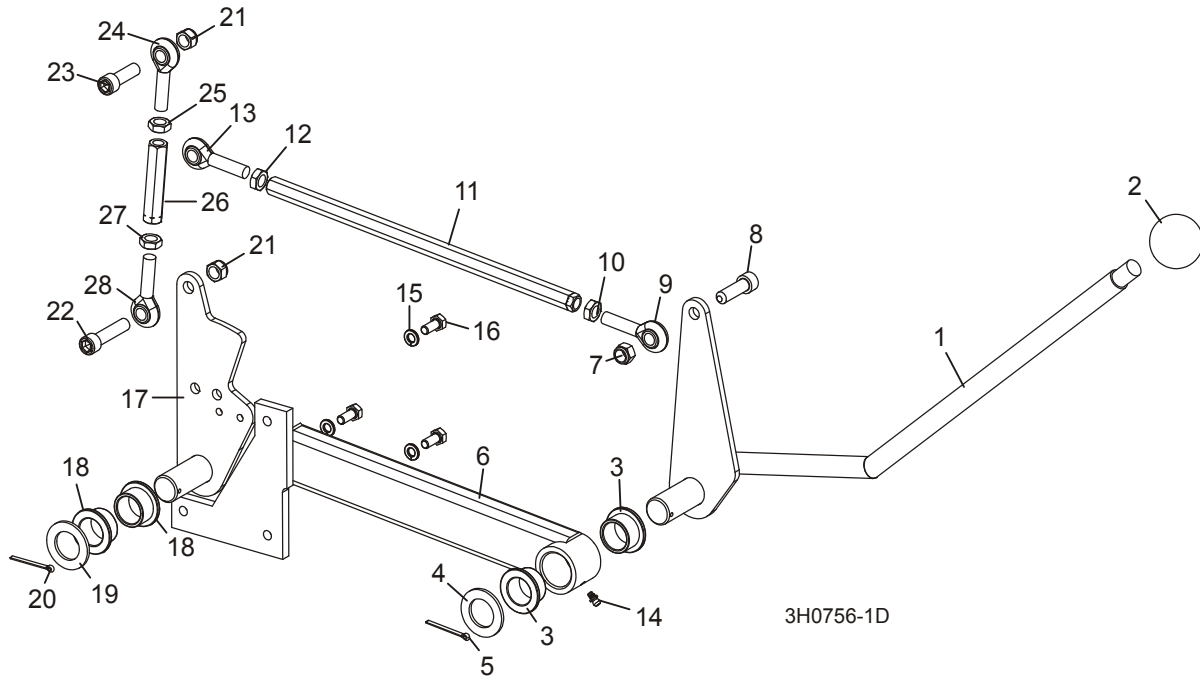

REF	DESCRIPTION (◆ Indicates Parts Available In Assemblies Only)	PART #	QTY.	
	HANDLE ASSEMBLY, EXTENDED CLUTCH/BRAKE	016317	1	
1	Lever, Clutch/Brake	016295	1	◆
2	Knob, Plastic Round	P04211	1	
3	Bushing, Clutch/Brake Pivot	P737	2	
4	Washer, Clutch/Brake Pivot	P116	1	
5	Pin, 1/8" X 1 1/2" Cotter	F05012-49	1	
6	Extension Weldment, Clutch Handle	015241	1	
7	Nut, 7/16-20 Nylon Lock	F05010-83	1	
8	Screw, 7/16-20 x 1 1/2" Socket Head	F05007-55	1	
9	Rod End, 7/16-20 Left Hand Thread	P11578	1	
10	Nut, 7/16-20 Hex Jam Left Hand Thread	F05010-87	1	
11	Rod, Clutch Extension	015073	1	
12	Nut, 7/16-20 Hex Jam	F05010-38	1	
13	Rod End, 7/16-20 Right Hand Thread	P11579	1	
14	Fitting, 3/16" Straight Grease	P04107	1	
15	WASHER, 5/16" SPLIT LOCK	F05011-13	3	
16	BOLT, 5/16-18 X 3/4" HEX HEAD	F05006-5	3	
17	PLATE WELDMENT, CLUTCH PIVOT	016296	1	
18	BUSHING, CLUTCH/BRAKE PIVOT	P737	2	
19	WASHER, CLUTCH/BRAKE PIVOT	P116	1	
20	PIN, 1/8" X 1 1/2" COTTER	F05012-49	1	

4

Saw Head*Clutch/Brake Lever Assembly (D47/D51)*

21	NUT, 7/16-20 HEX NYLON LOCK	F05010-83	2	
22	BOLT, 7/16-20 X 2" SOCKET HEAD	F05007-120	1	
23	BOLT, 7/16-20 X 1 1/2" SOCKET HEAD	F05007-55	1	
	TURNBUCKLE ASSEMBLY, 3 1/2" CLUTCH/BRAKE LEVER	A11576	1	
24	Rod End, 7/16-20 Right Hand Thread	P11579	1	
25	Nut, 7/16-20 Hex Jam	F05010-38	1	
26	Turnbuckle, 3 1/2" Clutch/Brake Lever	S12262	1	◆
27	Nut, 7/16-20 Hex Jam Left Hand Thread	F05010-87	1	
28	Rod End, 7/16-20 Left Hand Thread	P11578	1	

4.4 Clutch/Brake Lever Assembly (E25)

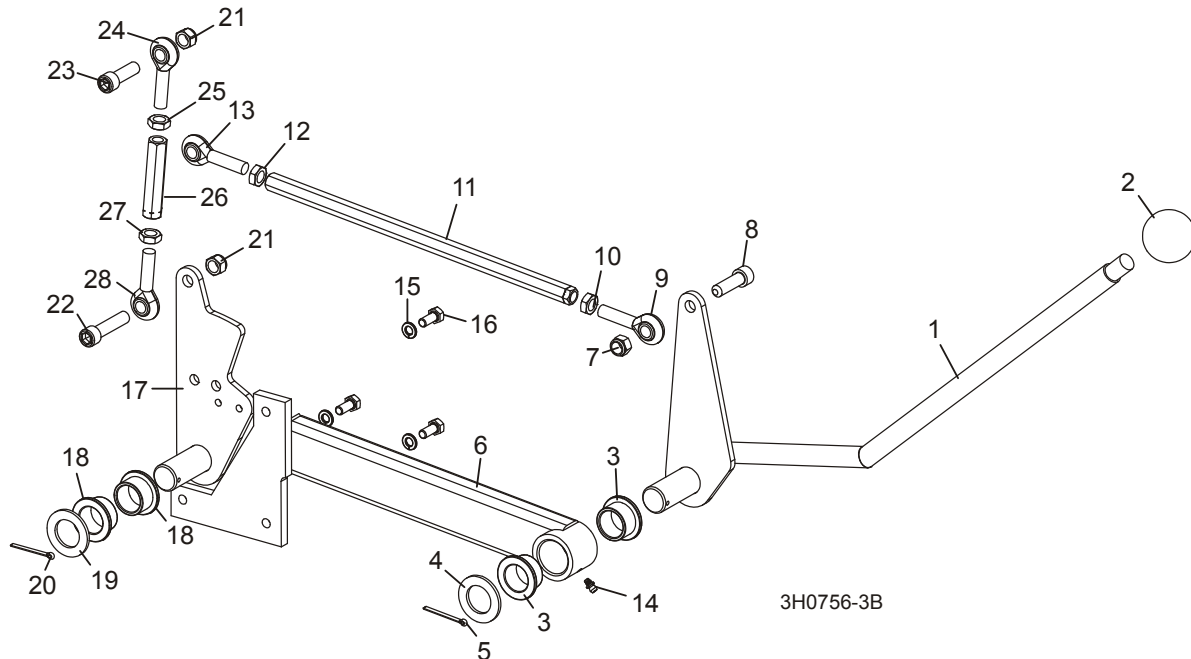

REF	DESCRIPTION (◆ Indicates Parts Available In Assemblies Only)	PART #	QTY.	
	HANDLE ASSEMBLY, EXTENDED CLUTCH/BRAKE	016317	1	
1	Lever, Clutch/Brake	016295	1	◆
2	Knob, Plastic Round	P04211	1	
3	Bushing, Clutch/Brake Pivot	P737	2	
4	Washer, Clutch/Brake Pivot	P116	1	
5	Pin, 1/8" X 1 1/2" Cotter	F05012-49	1	
6	Extension Weldment, Clutch Handle	015241	1	
7	Nut, 7/16-20 Nylon Lock	F05010-83	1	
8	Screw, 7/16-20 x 1 1/2" Socket Head	F05007-55	1	
9	Rod End, 7/16-20 Left Hand Thread	P11578	1	
10	Nut, 7/16-20 Hex Jam Left Hand Thread	F05010-87	1	
11	Rod, Clutch Extension	015073	1	
12	Nut, 7/16-20 Hex Jam	F05010-38	1	
13	Rod End, 7/16-20 Right Hand Thread	P11579	1	
14	Fitting, 3/16" Straight Grease	P04107	1	
15	WASHER, 5/16" SPLIT LOCK	F05011-13	3	
16	BOLT, 5/16-18 X 3/4" HEX HEAD	F05006-5	3	
17	PLATE WELDMENT, CLUTCH PIVOT	016296	1	
18	BUSHING, CLUTCH/BRAKE PIVOT	P737	2	
19	WASHER, CLUTCH/BRAKE PIVOT	P116	1	
20	PIN, 1/8" X 1 1/2" COTTER	F05012-49	1	

4

Saw Head

Clutch/Brake Lever Assembly (E25)

21	NUT, 7/16-20 HEX NYLON LOCK	F05010-83	2	
22	BOLT, 7/16-20 X 2" SOCKET HEAD	F05007-120	1	
23	BOLT, 7/16-20 X 1 1/2" SOCKET HEAD	F05007-55	1	
	TURNBUCKLE ASSEMBLY, 3" CLUTCH/BRAKE LEVER	A12304	1	
	TURNBUCKLE ASSEMBLY, 3 1/2" CLUTCH/BRAKE LEVER (50HZ ELECTRIC ONLY)	A11576 ¹	1	
24	Rod End, 7/16-20 Right Hand Thread	P11579	1	
25	Nut, 7/16-20 Hex Jam	F05010-38	1	
26	Turnbuckle, 3" Clutch/Brake Lever	S11577	1	◆
	Turnbuckle, 3 1/2" Clutch/Brake Lever (50Hz Electric Only)	S12262 ¹	1	◆
27	Nut, 7/16-20 Hex Jam Left Hand Thread	F05010-87	1	
28	Rod End, 7/16-20 Left Hand Thread	P11578	1	

¹ Alternate parts for 50Hz Electric operation. Complete conversion kit available (Part Number 015863).

4.5 Clutch Mount Assembly

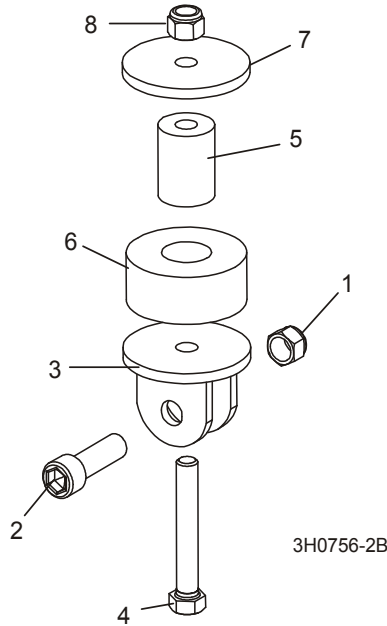

REF	DESCRIPTION (◆ Indicates Parts Available In Assemblies Only)	PART #	QTY.
1	NUT, 7/16-20 HEX NYLON LOCK	F05010-83	1
2	BOLT, 7/16-20 X 1 1/2" SOCKET HEAD	F05007-55	1
3	BRACKET, CLUTCH MOUNT	W12411	1
4	BOLT, 3/8-16 X 2 1/2" HEX HEAD	F05007-157	1
5	SPACER, MOTOR MOUNT VIBRATION BUSHING	016316	1
6	BUSHING, MOTOR MOUNT VIBRATION	P05032	1
7	WASHER, .40" I.D. X 1.44" O.D. X .18" THICK	021276	1
8	NUT, 3/8-16 NYLON LOCK	F05010-10	1

4 Saw Head Brake Assembly

4.6 Brake Assembly

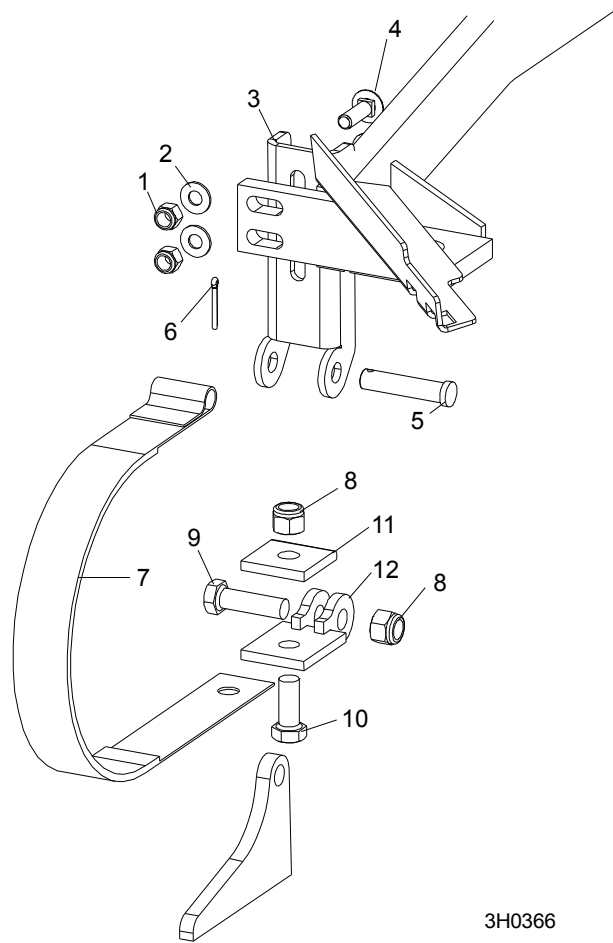

3H0366

REF	DESCRIPTION (◆ Indicates Parts Available In Assemblies Only)	PART #	QTY.
	STRAP RETROFIT, SUPER BRAKE	014441	1
1	Nut, 3/8-16 Nylon Lock	F05010-10	2
2	Washer, 3/8" SAE Flat	F05011-3	2
3	Bracket, Upper Super Brake Strap Mount	014395	1
4	Bolt, 3/8-16 x 1 1/4" Carriage Head Grade 5	F05007-127	2
5	Pin, 1/2" x 2 1/4" Clevis	F05012-81	1
6	Pin, 1/8" x 1" Cotter	F05012-1	1
7	Strap, Upper Pivot Metal Brake	014391	1
8	Nut, 1/2-13 Nylon Lock	F05010-8	2
9	Bolt, 1/2-13 x 1 3/4" Hex Head Grade 5	F05008-88	1
10	Bolt, 1/2-13 x 1 1/4" Hex Head Grade 5	F05008-37	1
11	Plate, Brake Strap Clamp	S04195	1
12	Bracket, Lower Super Brake Strap Mount	014392	1

4.7 Board Return Assembly

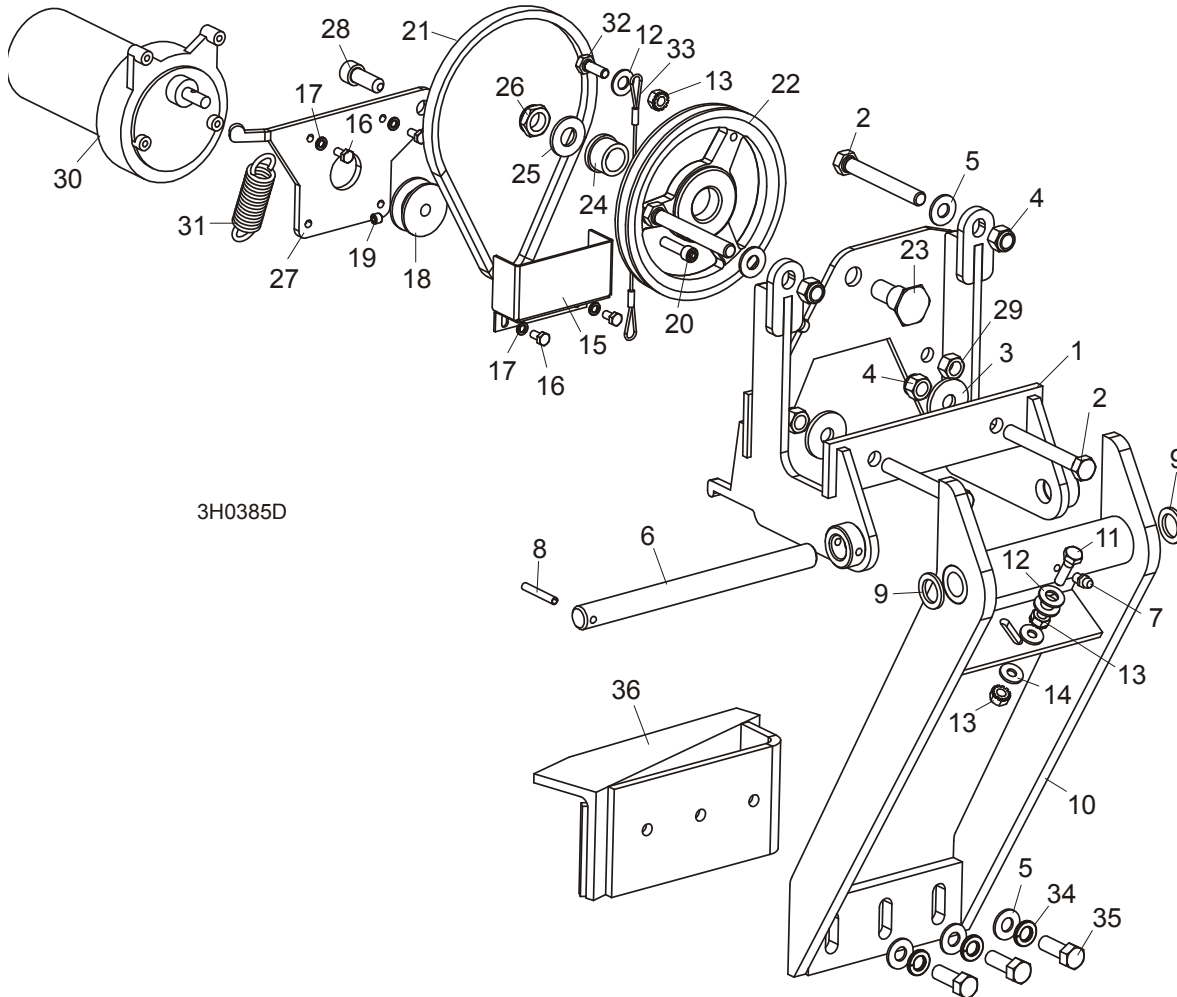

REF	DESCRIPTION (◆ Indicates Parts Available In Assemblies Only)	PART #	QTY.
	RETURN ASSEMBLY, BOARD	015209	1
1	Mount Weldment, Board Return	015215	1
2	Bolt, 3/8-16 x 3" Full Thread Hex Head	F05007-1	4
3	Washer, 1/8" x 1 1/4"	015336	2
4	Nut, 3/8-16 Hex Nylon Lock	F05010-10	4
5	Washer, 3/8" Flat	F05011-3	5
6	Rod Kit, Board Return Replacement Pivot	016272	1
7	Fitting, 1/4-28 Grease	P05060	1
8	Pin, 3/16 x 1 1/4" Roll	F05012-16	1
9	Washer, 5/8" x 15/16" x .094 Nylon	F05011-19	2
10	Arm Weldment, Board Return	015210	1
11	Screw, 1/4-20 x 3/4" Full Thread Hex Head	F05005-1	1

4

Saw Head*Board Return Assembly*

12	Washer, 5/16" SAE Flat	F05011-17	3	
13	Nut, 1/4-20 Self-Locking	F05010-9	3	
14	Washer, 1/4" SAE Flat	F05011-11	2	
15	Guard, Board Return Belt	015007	1	
16	Screw, #10-32 x 1/2" Hex Head Machine	F05004-60	4	
17	Washer, #10 Split Lock	F05011-20	4	
18	Pulley, 1.42" x .32"	015074	1	
19	Screw, 1/4-28 x 1/4" Socket Head Cup Point Set	F05005-105	1	
20	Bolt, 1/4-20 x 1" Socket Head	F05005-89	1	
21	Belt, 3L190	015477	1	
22	Pulley, OK50 x 1/2" Modified	015224	1	
23	Bolt, Idler Pulley Pivot	015221	1	
24	Bushing, 5/8" x 7/8" x 1/2" Bronze	P05135	1	
25	Washer, 1/2" SAE Flat	F05011-2	1	
26	Nut, 1/2-20 Nylon Lock Jam	F05010-79	1	
27	Plate, Motor Pivot	015220	1	
28	Bolt, 3/8-16 x 1" Socket Head	F05007-52	1	
29	Nut, 3/8-16 Self-Locking	F05010-25	1	
30	Motor, Current Applications 1/30HP 12VDC Gear	079214	1	
	Gear Kit, Motor Replacement	061232	1	
	Brush Kit, Gear Motor Replacement	061234	1	
	Shaft Kit, Gear Motor Replacement	061233	1	
31	Spring, 3/4" x 2 7/8" x 12 Gauge	015479	1	
32	Bolt, 1/4-20 x 1" Hex Head Grade 5	F05005-101	1	
33	Cable, Board Return	016090	1	
34	Washer, 3/8" Split	F05011-4	3	
35	Bolt, 3/8-16 x 1" Hex Head	F05007-7	3	
36	Angle, Board Return	015652	1	

4.8 Water Lube Assembly (Gas Only)

LT40 Super

Rev. J7.17+

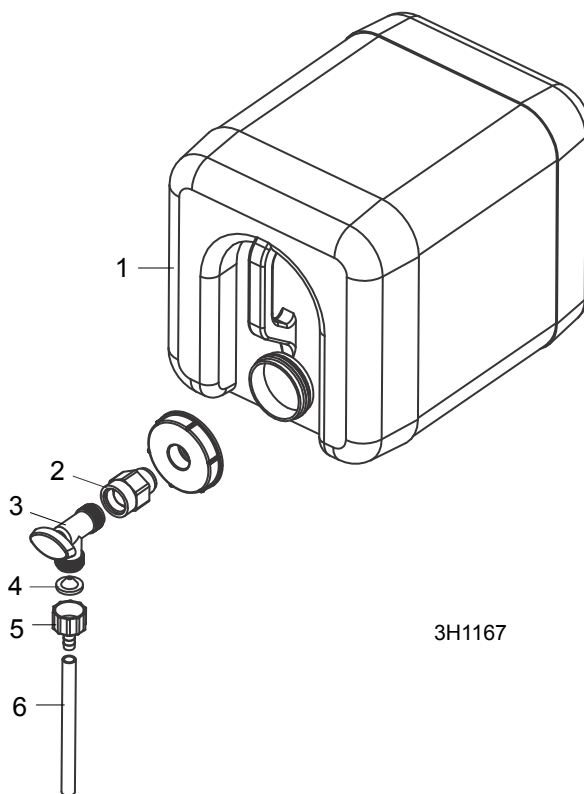

REF	DESCRIPTION (◆ Indicates Parts Available In Assemblies Only)	PART #	QTY.
1	BOTTLE ASSEMBLY, WATER LUBE W/CAP	014642	1
	O-ring, Water Bottle Cap	061372 ¹	1
2	FITTING, 3/4FPT X 3/4MPT	014636	1
3	FITTING, WATER LUBE SHUTOFF VALVE	014100	1
4	FILTER, WATER LUBE	016086 ²	1
5	FITTING, 5/8" NPT TO 3/8" HOSE BARB	014113	1
6	TUBING, WATER LUBE 3/8" I.D.	R01885	7 ft.
	COVER, 5 GAL. WATER BOTTLE OPTIONAL (NOT SHOWN)	CBOTTLE	1

¹ If the water bottle cap keeps leaking, add this o-ring to the cap. Leave the existing o-ring installed.

² Filter recommended for Super models to prevent debris from entering water lube solenoid valve.

4 Saw Head

Water Lube Assembly (Gas Only)

4.9 Water Lube Assembly (Gas Only)

LT40 Super

Prior to Rev. J7.17

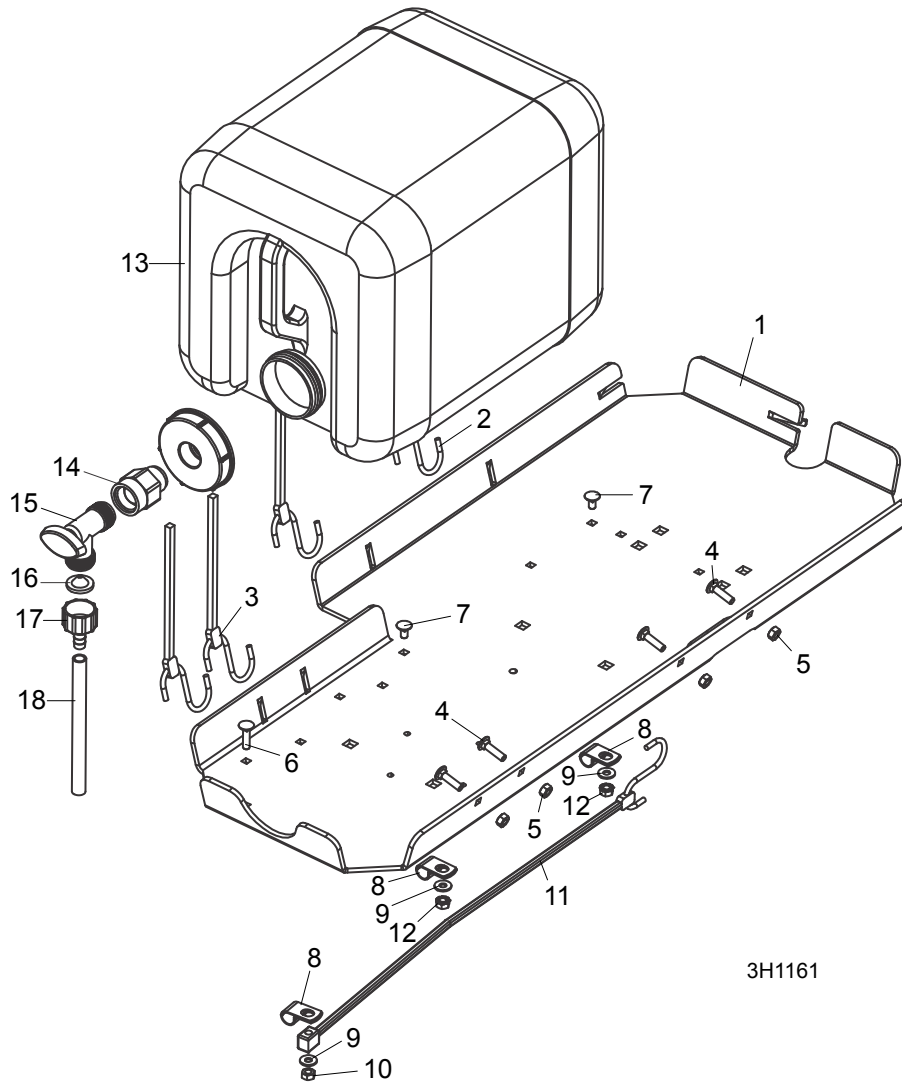

REF	DESCRIPTION (◆ Indicates Parts Available In Assemblies Only)	PART #	QTY.
	TRAY ASSEMBLY, 5-GALLON GAS TANK/WATER BOTTLE	076482 ¹	1
1	Tray, Fuel Tank/Water Bottle	076484	1
2	Strap, 20" Rubber	P11668	2
3	Strap, 20" Rubber	P11668	2
4	Bolt, 1/4-20 X 1" Carriage Head	F05005-34	4
5	Nut, 1/4-20 Hex Lock	F05010-21	4
6	BOLT, 1/4-20 X 1" CARRIAGE HEAD	F05005-34	1
7	BOLT, 1/4-20 X 1/2" CARRIAGE HEAD	F05005-33	2

8	CLAMP, 1/2" EMT HOSE	P07584	3	
9	WASHER, 1/4" SAE FLAT	F05011-11	3	
10	NUT, 1/4-20 HEX LOCK	F05010-21	1	
11	STRAP, 15" RUBBER	P07461	1	
12	NUT, 1/4-20 SELF-LOCKING	F05010-9	2	
13	BOTTLE ASSEMBLY, WATER LUBE W/CAP	014642	1	
	O-ring, Water Bottle Cap	061372 ²	1	
14	FITTING, 3/4FPT X 3/4MPT	014636	1	
15	FITTING, WATER LUBE SHUTOFF VALVE	014100	1	
16	FILTER, WATER LUBE	016086	1	
17	FITTING, 5/8" NPT TO 3/8" HOSE BARB	014113	1	
18	TUBING, WATER LUBE 3/8" I.D.	R01885	7 ft.	
	COVER, 5 GAL. WATER BOTTLE OPTIONAL (NOT SHOWN)	CBOTTLE	1	

¹ Replaced A11685 Fuel Tank/Water Bottle Tray Assembly ([See Section 4.10](#)) to accommodate new gas tank meeting regulation standards (LT40Super Rev. J7.16).

² If the water bottle cap keeps leaking, add this o-ring to the cap. Leave the existing o-ring installed.

4 Saw Head
Water Lube Assembly (Diesel & Electric Only)

4.10 Water Lube Assembly (Diesel & Electric Only)

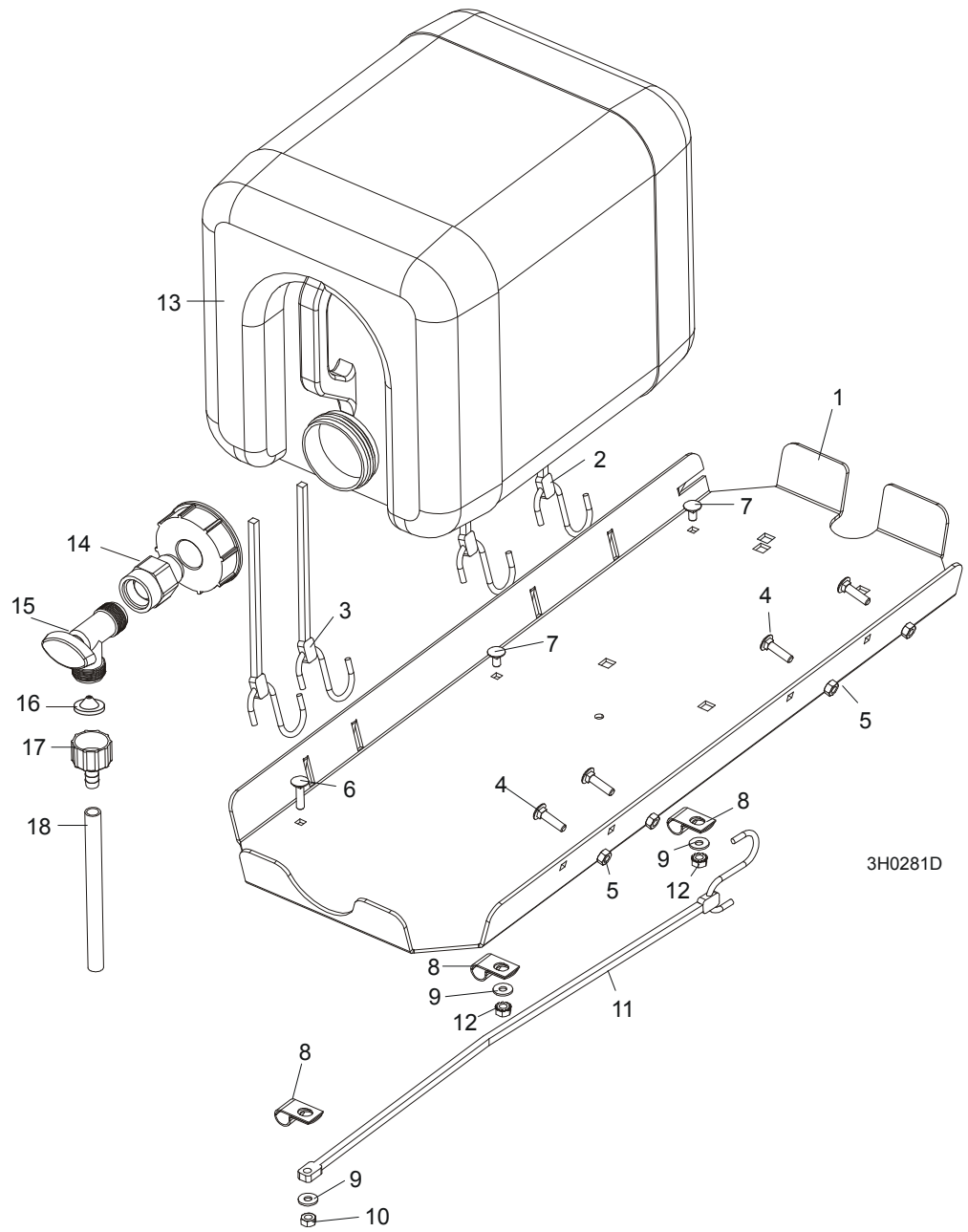

REF	DESCRIPTION (◆ Indicates Parts Available In Assemblies Only)	PART #	QTY.
	TRAY ASSEMBLY, FUEL TANK/WATER BOTTLE	A11685	1
1	Tray, Fuel Tank/Water Bottle	S11684	1
2	Strap, 24" Rubber (For Fuel Tank - See Engine Manual)	P11258	2
3	Strap, 20" Rubber	P11668	2
4	Bolt, 1/4-20 X 1" Carriage Head	F05005-34	4

5	Nut, 1/4-20 Hex Lock	F05010-21	4	
6	BOLT, 1/4-20 X 1" CARRIAGE HEAD	F05005-34	1	
7	BOLT, 1/4-20 X 1/2" CARRIAGE HEAD	F05005-33	2	
8	CLAMP, 1/2" EMT HOSE	P07584	3	
9	WASHER, 1/4" SAE FLAT	F05011-11	3	
10	NUT, 1/4-20 HEX LOCK	F05010-21	1	
11	STRAP, 15" RUBBER	P07461	1	
12	NUT, 1/4-20 SELF-LOCKING	F05010-9	2	
13	BOTTLE ASSEMBLY, WATER LUBE W/CAP	014642 ¹	1	
	O-ring, Water Bottle Cap	061372 ²	1	
14	FITTING, 3/4FPT X 3/4MPT	014636	1	
15	FITTING, WATER LUBE SHUTOFF VALVE	014100	1	
16	FILTER, WATER LUBE	016086 ³	1	
17	FITTING, 5/8" NPT TO 3/8" HOSE BARB	014113	1	
18	TUBING, WATER LUBE 3/8" I.D.	R01885	7 ft.	

¹ Use Water Bottle Assembly w/Cap 014642 to service all bottle/cap combinations previously supplied. Bottle 014367, 61mm Cap 014773 and 70mm Cap 036744 no longer available separately.

² If the water bottle cap keeps leaking, add this o-ring to the cap. Leave the existing o-ring installed.

³ Filter recommended for Super models to prevent debris from entering water lube solenoid valve.

4 Saw Head

Blade Housing Covers

4.11 Blade Housing Covers

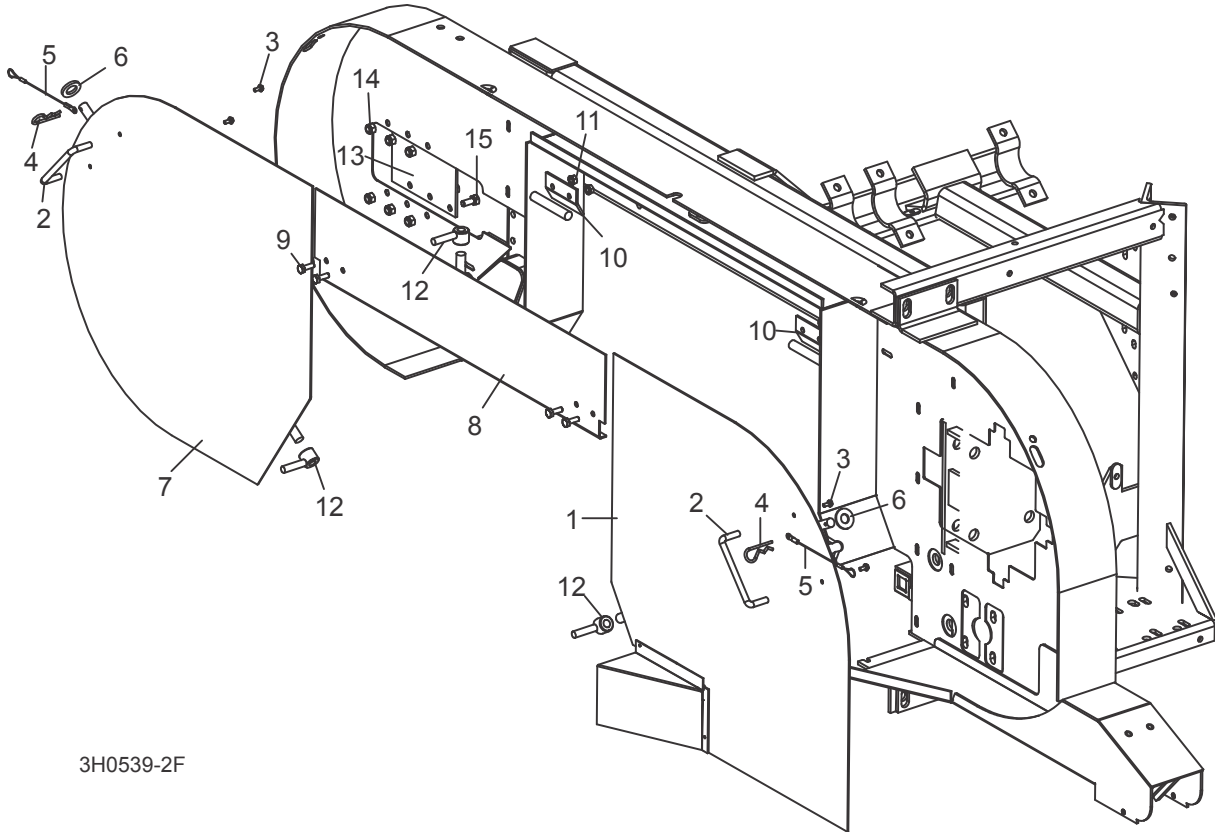

3H0539-2F

REF	DESCRIPTION (◆ Indicates Parts Available In Assemblies Only)	PART #	QTY.	
	COVER ASSEMBLY, DRIVE SIDE BLADE HOUSING WITH HANDLE	015937 ¹	1	
1	Cover, Drive Side Blade Housing (Includes Cover Decal - See Section 4.12)	015911	1	◆
2	Handle, Blade Housing Cover	P08065	1	
3	Screw, #8-32 X 3/8" Self-Tap	F05015-8	2	
	Pin Assembly, Cover Retainer	A12812	1	
4	Pin, Safety Retainer	P05059	1	
5	Cable, 3/64" x 6" Lanyard	016030	1	
6	Washer, 1/2" ID x 1 1/8" OD x .093" Rubber	F05011-87	1	
	COVER, IDLE SIDE BLADE HOUSING WITH HANDLE	A09419	1	
7	Cover, Idle Side Blade Housing (Includes Cover Decal - See Section 4.12)	W09351	1	◆
2	Handle, Blade Housing Cover	P08065	1	
3	Screw, #8-32 X 3/8" Self-Tap	F05015-8	2	
	Pin Assembly, Cover Retainer	A12812	1	
4	Pin, Safety Retainer	P05059	1	
5	Cable, 3/64" x 6" Lanyard	016030	1	
6	Washer, 1/2" ID x 1 1/8" OD x .093" Rubber	F05011-87	1	

8	COVER, MIDDLE BLADE HOUSING	W07409	1	
	COVER, MIDDLE BLADE HOUSING (WIDE HEAD ONLY)	079509	1	
9	BOLT, 1/4-20 X 3/4" HEX HEAD	F05005-1	18	
10	HINGE, MIDDLE BLADE HOUSING COVER	S07522	2	
11	NUT, 1/4-20 SELF-LOCKING HEX	F05010-9	4	
12	NUT, COVER TURN	021145	3	
13	PLATE, IDLE BLADE WHEEL GUARD	S04433	1	
14	NUT, 5/16-18 HEX NYLON LOCK	F05010-58	6	
15	BOLT, 5/16-18 X 3/4" HEX HEAD GRADE 2	F05006-5	6	

¹ Removed (1) 015734 Sawdust Exit Funnel and (7) F04203-8 1/8" x 1/8" Aluminum Pop Rivet and changed to welded funnel to improve durability (LT40Super Rev. J7.16).

4 Saw Head

Saw Head Decals

4.12 Saw Head Decals

After 11/15/10

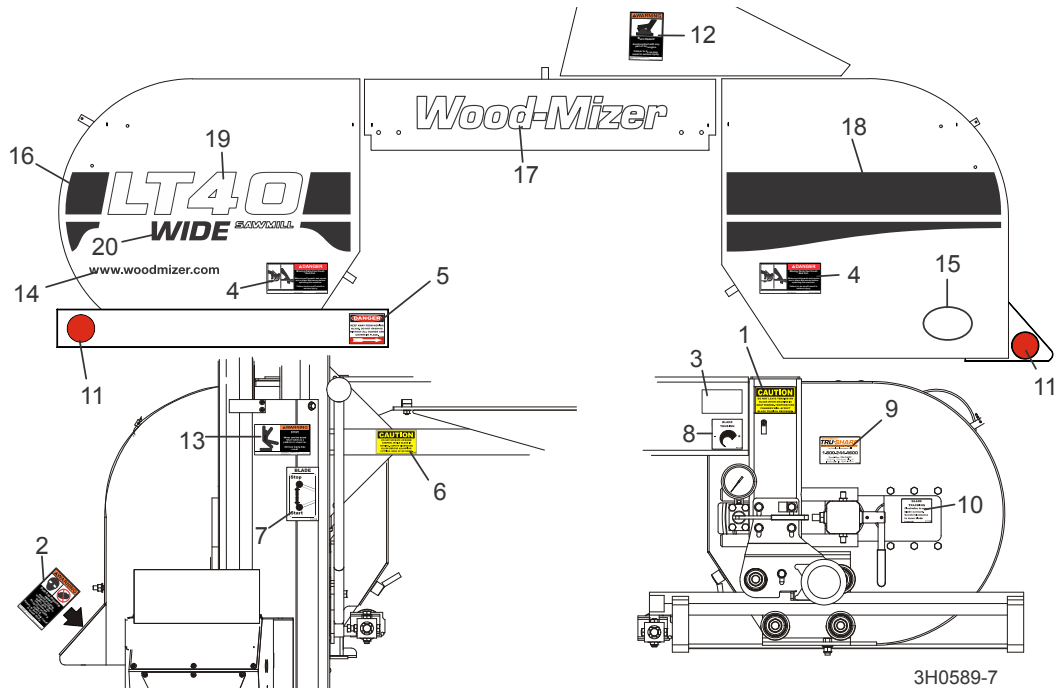

REF	DESCRIPTION (◆ Indicates Parts Available In Assemblies Only)	PART #	QTY.
1	DECAL, BLADE TENSION CAUTION	P10147	1
2	DECAL, SAWDUST CHUTE WARNING	P11754	1
3	DECAL, BLADE TENSION RANGES	P12373	1
4	DECAL, BLADE COVERS DANGER	033254	2
5	DECAL, BLADE DANGER ARROW RIGHT	S11752	1
6	DECAL, UP/DOWN CAUTION	S11762	1
7	DECAL, BLADE START/STOP	P11779	1
8	DECAL, BLADE TENSION INFO	P11790	1
9	DECAL, TRU-SHARP INFO	P12879	1
10	DECAL, BLADE ALIGNMENT INFO	P11789	1
11	DECAL, RED REFLECTIVE 2" ROUND	P07452	2
12	DECAL, HOT ENGINE WARNING	014419	1
13	DECAL, BOARD RETURN OPERATOR WARNING	016072	1
14	DECAL, WOOD-MIZER WEBSITE	003235	1
15	DECAL, 30 YEAR LOGO	065582	1
16	DECAL, LT40 IDLE SIDE BLACK EURO STRIPE	065023	1
17	DECAL, LT40/50 WHITE WOOD-MIZER LOGO	065025	1
18	DECAL, LT40/50 DRIVE SIDE BLACK EURO STRIPE	065026	1
19	DECAL, LT40 WHITE EURO LOGO	065024	1
20	DECAL, LT15/70 WIDE LOGO (WIDE HEAD ONLY)	074335	1

4.13 Saw Head Decals

Prior to 11/15/10

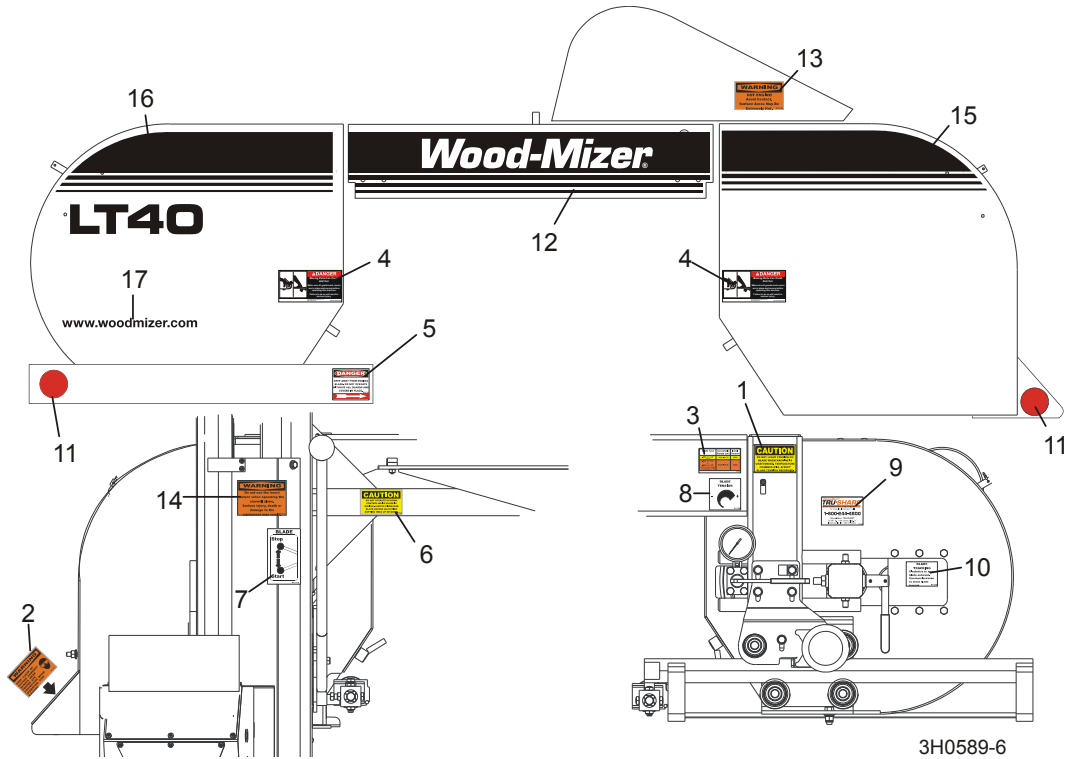

3H0589-6

REF	DESCRIPTION (◆ Indicates Parts Available In Assemblies Only)	PART #	QTY.
1	DECAL, BLADE TENSION CAUTION	P10147	1
2	DECAL, SAWDUST CHUTE WARNING	P11754	1
3	DECAL, BLADE TENSION RANGES	P12373	1
4	DECAL, BLADE COVERS DANGER	033254	2
5	DECAL, BLADE DANGER ARROW RIGHT	S11752	1
6	DECAL, UP/DOWN CAUTION	S11762	1
7	DECAL, BLADE START/STOP	P11779	1
8	DECAL, BLADE TENSION INFO	P11790	1
9	DECAL, TRU-SHARP INFO	P12879	1
10	DECAL, BLADE ALIGNMENT INFO	P11789	1
11	DECAL, RED REFLECTIVE 2" ROUND	P07452	2
12	DECAL, MIDDLE COVER	003244	1
13	DECAL, HOT ENGINE WARNING	014419	1
14	DECAL, BOARD RETURN OPERATOR WARNING	016072	1
15	DECAL, BLADE HOUSING COVER (DRIVE SIDE)	003243	1
16	DECAL, BLADE HOUSING COVER (IDLE SIDE LT30)	003245	1
	DECAL, BLADE HOUSING COVER (IDLE SIDE LT40)	003246	1
17	DECAL, WOOD-MIZER WEBSITE	003235	1

4.14 Drive Belt Covers

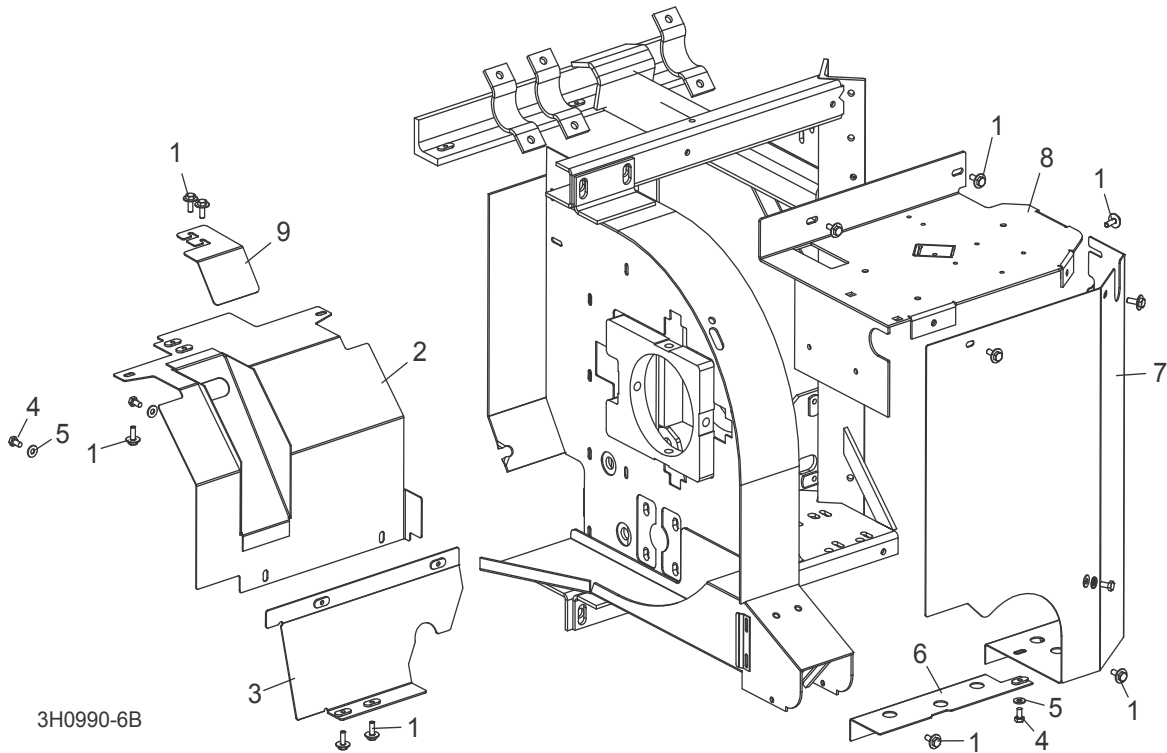

REF	DESCRIPTION (◆ Indicates Parts Available In Assemblies Only)	PART #	QTY.
1	BOLT, 1/4-20 X 3/4" HEX HEAD WITH CONICAL WASHER	F05005-134	15
2	GUARD WELDMENT, SUPER/REMOTE LOWER DRIVE BELT	006026 ¹	1
3	MOUNT WELDMENT, LOWER DRIVE BELT	006025	1
4	BOLT, 1/4-20 X 1/2" HEX HEAD	F05005-15	3
5	WASHER, 1/4" SAE FLAT	F05011-11	3
6	GUARD WELDMENT, LOWER UP/DOWN	015654	1
7	GUARD, SUPER DRIVE PULLEY SIDE	008776	1
8	GUARD, DRIVE PULLEY TOP	059599	1
9	PLATE, LT40 BELT GUARD COVER	074752	1

¹ For sawmills equipped with standard manual clutch handle only. See Autoclutch Option manual for alternate guards.

4.15 Sawdust Chute

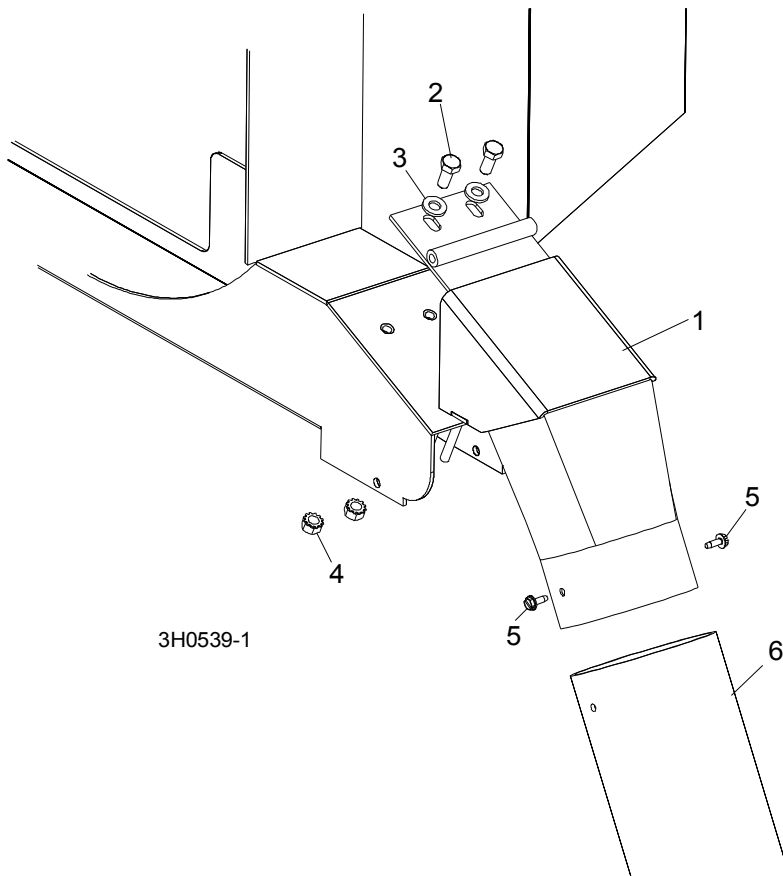

3H0539-1

REF	DESCRIPTION (◆ Indicates Parts Available In Assemblies Only)	PART #	QTY.
1	CHUTE WELDMENT, SAWDUST	015466	1
2	BOLT, 5/16-18 X 3/4" HEX HEAD GRADE 2	F05006-5	2
3	WASHER, 5/16" SAE FLAT	F05011-17	2
4	NUT, 5/16-18 SELF-LOCKING HEX	F05010-20	2
5	BOLT, #10-24 X 1/2" SELF-TAPPING	F05015-7	2
6	TUBING, RUBBER SAWDUST	016727	1
	STRAP, 20" RUBBER W/HOOK	P11668	1
	BOLT, 1/4-20 X 1 1/4" HEX HEAD FULL THREAD	F05005-3	1
	WASHER, 1/4" SAE FLAT	F05011-11	1
	NUT, 1/4-20 LOCK	F05010-21	1

4 Saw Head
Debarker Wire Box/Hole Plugs

4.16 Debarker Wire Box/Hole Plugs

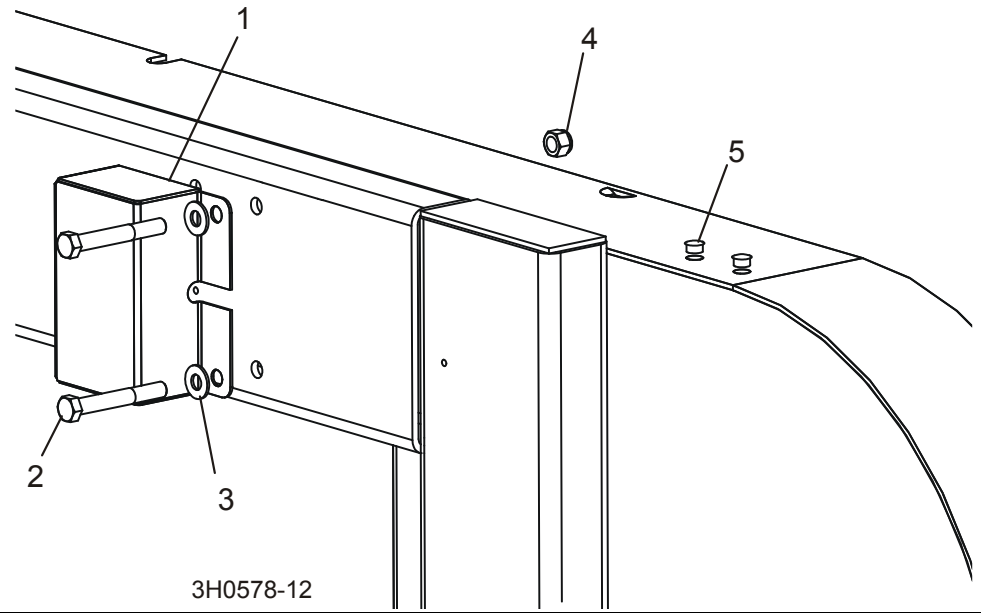

REF	DESCRIPTION (◆ Indicates Parts Available In Assemblies Only)	PART #	QTY.
1	BOX, DEBARKER WIRE STORAGE	023616	1
2	BOLT, 3/8-16 X 2 3/4" HEX HEAD	F05007-29	2
3	WASHER, 3/8" SAE FLAT	F05011-3	2
4	NUT, 3/8-16 HEX NYLON LOCK	F05010-10	2
5	PLUG, 13/32" PLASTIC HOLE	014537	2

SECTION 5 ENGINE OPTIONS

LT30/LT40 Super

REF	DESCRIPTION	MASTER	Elec. Info	
	D47 YANMAR ENGINE OPTION (SEE ENGINE OPTION MANUAL)	M1584	M1585	
	E25 LINCOLN ENGINE OPTION (SEE ENGINE OPTION MANUAL)	M772	M863	

6 Options

SECTION 6 OPTIONS & ADDITIONAL INCLUDED EQUIPMENT

LT30/LT40 Super

REF	DESCRIPTION (◆ Indicates Parts Available In Assemblies Only)	MASTER	
AVAILABLE OPTIONS			
	ACCUSET 2 (SEE MANUAL)	M1517	
	AUTOCLUTCH (SEE MANUAL)	M926	
	BED EXTENSION (SEE MANUAL)	M530	
	DEBARKER - MARK II (SEE MANUAL)	M546	
	FINE ADJUST OUTRIGGERS (2008) (SEE MANUAL)	M1524	
	HYDRAULIC LOG LOADER/TURNER (SEE MANUAL)	M1701	
	LASER SIGHT (SEE MANUAL)	M899	
	LOG DECK PACKAGE (SEE MANUAL)	M823	
	LOG TURNER (SEE MANUAL)	M620	
	LUBEMIZER (SEE MANUAL)	M930	
	OPERATOR'S SEAT (SEE MANUAL)	M859	
	TOE BOARD (SEE MANUAL)	M627	
	WINCH (SEE MANUAL)	M682	

SECTION 7 CONTROL & BATTERY BOXES

7.1 Control Assembly

LT40 Super

Rev. J7.05+

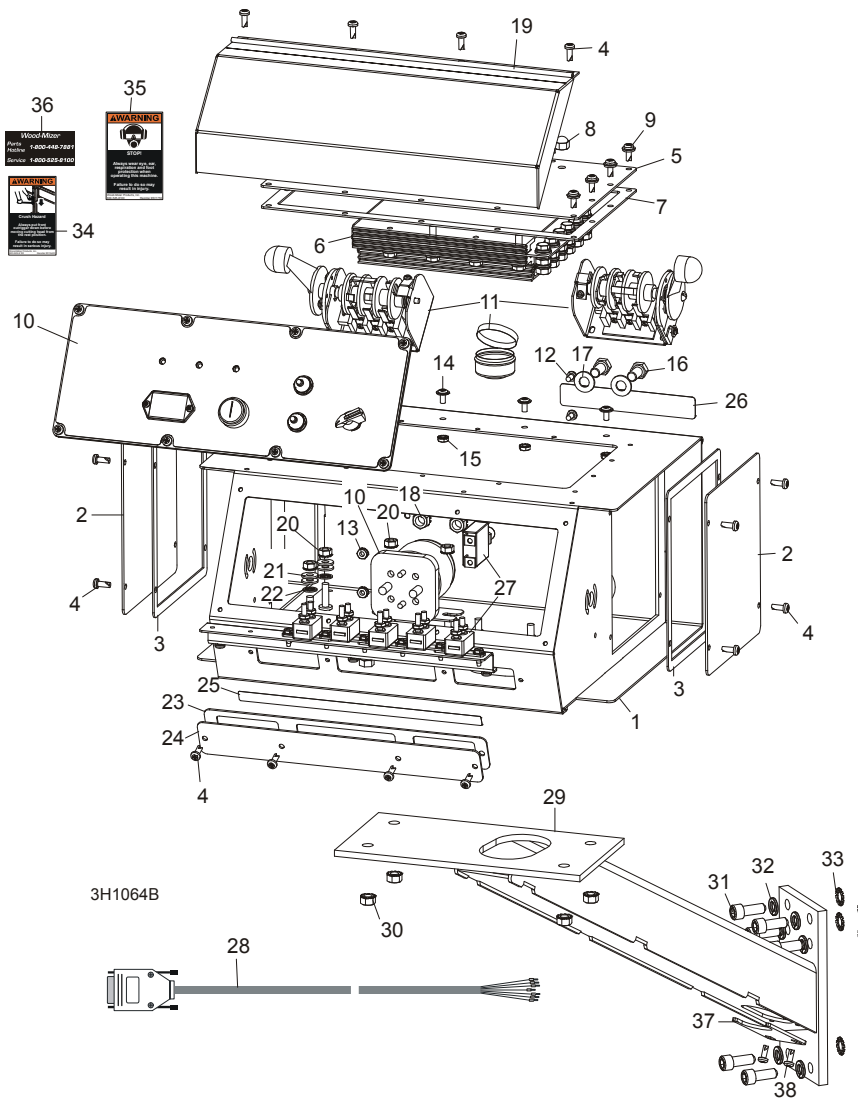

REF	DESCRIPTION (◆ Indicates Parts Available In Assemblies Only)	PART #	QTY.	
	COVER, SAWMILL CONTROL CONSOLE	015764	1	
	COVER, SAWMILL CONTROL CONSOLE W/ACCUSSET	036352	1	
	CONTROL BOX ASSEMBLY, E25 DUAL-AXIS	069426	1	
	CONTROL BOX ASSEMBLY, D35/D47 DUAL-AXIS (EXPORT ONLY)	069422	1	
1	Box Weldment, Sawmill Control	025823	1	◆
2	Panel, Control Box Side	006473	2	

7

Control & Battery Boxes

Control Assembly

3	Gasket, Side Panel Control	015274	2	
4	Screw, #10-24 x 1/2" Pan Head	F05015-17	16	
	Drive Assembly, Super NR Dual-Axis	069415	1	◆
5	Plate, Super NR Dual-Axis Mounting	059648	1	
6	Control Assembly, Dual-Axis Motor	057821LS-FR	1	
	PCB Assembly, Transient Voltage Suppression	069556	1	
7	Gasket, Dual-Axis Mounting Plate	069413	1	
8	Nut, 1/4-20 18-8 Stainless Acorn	F05010-204	4	
9	Screw, #10-24 x 1/2" Phillips Head	F05004-186	14	
10	Front Control Panel & Wiring Harnesses (See Section 7.6)	N/A	1	
11	Drum Switches (See Section 7.3)	N/A	1	
12	Screw, #10-24 x 3/8" Phillips Pan Head	F05004-3	2	
13	Nut, #10-24 Self Locking	F05010-14	2	
14	Screw, #10-24 x 3/8" Phillips Pan Head Machine with Neo Washer	F05004-148	4	
15	Nut, #10-24 Self-Locking Hex	F05010-14	4	
16	Bolt, 3/8-16 x 3/4" Hex Head	F05007-27	2	
17	Washer, 3/8" SAE Flat	F05011-3	2	
18	Nut, 3/8" Lock Nut	F05010-19	2	
19	Cover, Control Box Hinged	015304	1	
20	Nut, 1/4-20 Self Locking	F05010-9	4	
21	Washer, 1/4" SAE Flat	F05011-11	4	
22	Washer, 1/4" Interior Star Heavy Duty Lock	F05011-69	2	
23	Gasket, Front Access Panel	015266	1	
24	Panel, Control Box Front Access	015376	1	
25	Decal, Front Circuit Breaker ID (Super NR Dual-Axis)	069412	1	
26	Decal, Rear Circuit Breaker ID (Super NR Dual-Axis)	069414	1	
27	Circuit Breakers (See Section 7.4)	N/A	1	
28	Harness Assembly, Dual-Axis Motor Control Non-Remote	053355	1	
29	MOUNT WELDMENT, STANDARD CONTROL BOX	015236	1	
30	NUT, 5/16-18 SELF-LOCKING HEX	F05010-20	4	
31	BOLT, 3/8-16 X 1" SOCKET HEAD	F05007-52	6	
32	WASHER, 3/8" SPLIT LOCK	F05011-4	6	
33	WASHER, 3/8" EXTERIOR STAR LOCK	F05011-36	6	
34	DECAL, FRONT OUTRIGGER WARNING	015400	1	
35	DECAL, EAR/EYE PROTECTION WARNING	S11753	1	
36	DECAL, 800 NUMBER	S12117	1	
37	PLATE, PEDESTAL COVER	036381	1	
38	SCREW, #10-24 X 1/2" PAN HEAD	F05015-17	2	

7.2 Control Assembly

LT40 Super

Rev. J7.03 - J7.04

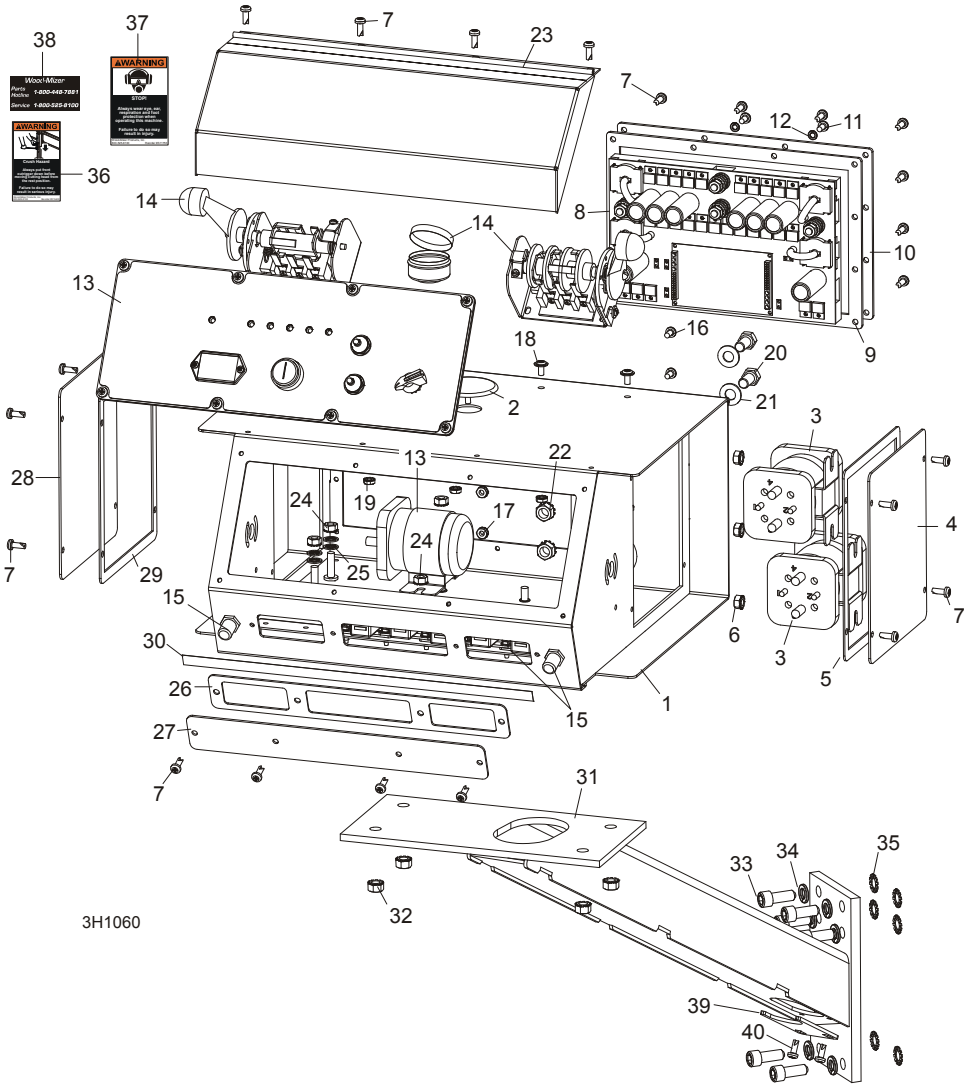

REF	DESCRIPTION (◆ Indicates Parts Available In Assemblies Only)	PART #	QTY.	
	COVER, SAWMILL CONTROL CONSOLE	015764	1	
	COVER, SAWMILL CONTROL CONSOLE W/ACCUSET	036352	1	
	CONTROL BOX ASSEMBLY, E25 2010	069345	1	
1	Box Weldment, Sawmill Control	047930	1	◆
2	Plug, AS125 Oiltite Painted	015673	1	
	Panel Assembly, Solenoid Up/Down 2010	069353	1	
3	Solenoid Kit, 200A 12V DPST	016370	2	
	Solenoid, 200A 12 DPST	015417	1	◆
	Diode Assembly, Solenoid Coil Chassis GND	015426	1	

7 Control & Battery Boxes

Control Assembly

4	Panel Weldment, Side	015307	1	
5	Gasket, Side Panel Control	015274	1	
6	Nut, 1/4-20 Self Locking	F05010-9	3	
	Up/Down Circuit Breaker (See Section 7.4)	N/A	1	
7	Screw, #10-24 x 1/2" Pan Head	F05015-17	28	
	Panel Assembly, Power Feed Control	051887 ¹	1	◆
8	Control Module, Power Feed	051667	1	◆
9	Gasket, Rear Panel	047938	1	
10	Plate, Power Feed Module	047698	1	
11	Screw, #10-24 X 3/8" Phillips Pan Head	F05004-3	6	
12	Washer, #10 Split Lock	F05011-20	6	
13	Front Control Panel & Wiring Harnesses (See Section 7.7)	N/A	1	
14	Drum Switches (See Section 7.3)	N/A	1	
15	Circuit Breakers (See Section 7.4)	N/A	1	
16	Screw, #10-24 x 3/8" Phillips Pan Head	F05004-3	2	
17	Nut, #10-24 Self Locking	F05010-14	2	
18	Screw, #10-24 x 3/8" Phillips Pan Head Machine with Neo Washer	F05004-148	4	
19	Nut, #10-24 Self-Locking Hex	F05010-14	4	
20	Bolt, 3/8-16 x 3/4" Hex Head	F05007-27	2	
21	Washer, 3/8" SAE Flat	F05011-3	2	
22	Nut, 3/8" Lock Nut	F05010-19	2	
23	Cover, Control Box Hinged	015304	1	
24	Nut, 1/4-20 Self Locking	F05010-9	4	
25	Washer, 1/4" Interior Star Heavy Duty Lock	F05011-69	4	
26	Gasket, Front Access Panel	015266	1	
27	Panel, Control Box Front Access	015376	1	
28	Panel Weldment, Side	006473	1	
29	Gasket, Side Panel Control	015274	1	
30	Decal, Circuit Breaker ID ('10 Super)	069354	1	
31	MOUNT WELDMENT, STANDARD CONTROL BOX	015236	1	
32	NUT, 5/16-18 SELF-LOCKING HEX	F05010-20	4	
33	BOLT, 3/8-16 X 1" SOCKET HEAD	F05007-52	6	
34	WASHER, 3/8" SPLIT LOCK	F05011-4	6	
35	WASHER, 3/8" EXTERIOR STAR LOCK	F05011-36	6	
36	DECAL, FRONT OUTRIGGER WARNING	015400	1	
37	DECAL, EAR/EYE PROTECTION WARNING	S11753	1	
38	DECAL, 800 NUMBER	S12117	1	
39	PLATE, PEDESTAL COVER	036381	1	
40	SCREW, #10-24 X 1/2" PAN HEAD	F05015-17	2	

¹ Power Feed Module 051887 discontinued 12/10. If sawmill not equipped with Accuset or Accuset 2 option, use kit 069460 to retrofit power feed with dual-axis motor control module. Use kit 052972 if sawmill equipped with original Accuset to retrofit to Accuset 2. Once sawmill upgraded to Accuset 2, use kit 069459 to retrofit for dual-axis control of power feed motor. If Accuset 2 is older than Rev. B.00 with original part 052974 single-axis control module (No MOT2A or MOT2B terminal studs), a new dual-axis module 057821LS-FR is required in addition to kit 069459.

7.3 Drum Switches

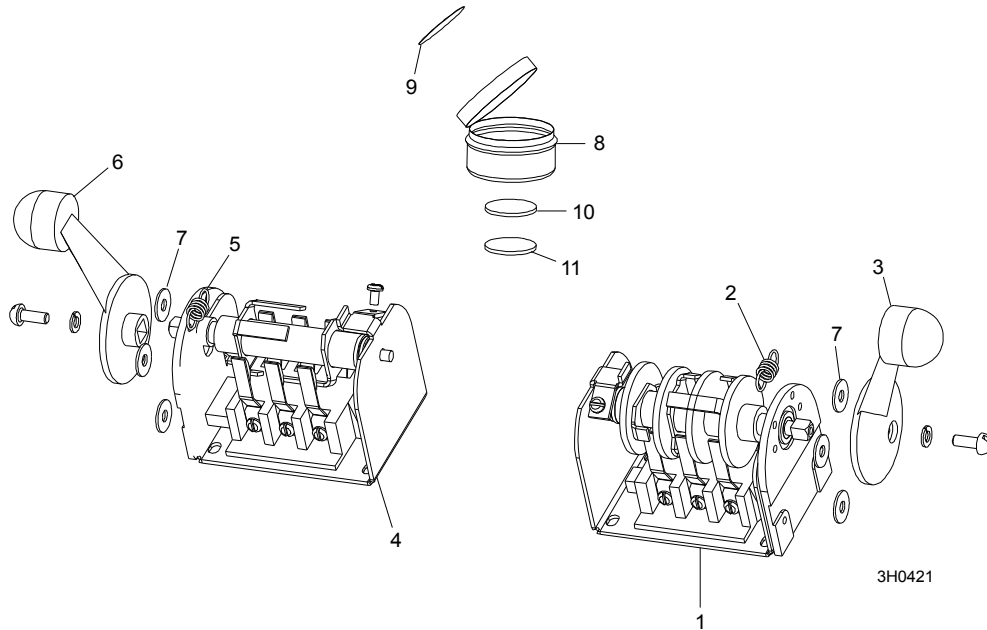

REF	DESCRIPTION (◆ Indicates Parts Available In Assemblies Only)	PART #	QTY.	
	SWITCH ASSEMBLY, UP/DOWN DRUM	E20440	1	
1	Switch, S12 Bulk Drum	E20440-B	1	◆
2	Spring, Drum Switch	P12570	1	
3	Handle, Drum Switch Replacement	P12500	1	
	SWITCH ASSEMBLY, POWER FEED DRUM	E20439	1	
4	Switch, S11 Bulk Drum	E20439-B	1	◆
5	Spring, Drum Switch	P12570	1	
6	Handle, Drum Switch Replacement	P12500	1	
7	WASHER, #8 SAE FLAT	F05011-41	6	
	CUP ASSEMBLY, DRUM SWITCH GREASE	A20463	1	
8	Cup, Plastic Container	P20464	1	◆
9	Decal, Grease Cup Label	P20467	1	
10	Pad, Velcro Loop	P20466	1	◆
11	Pad, Velcro Hook	P20465	1	◆
	Grease, High Temp Drum Switch	P20468	.025 lb	◆

7.4 Circuit Breakers

LT40 Super

Rev. J7.05+

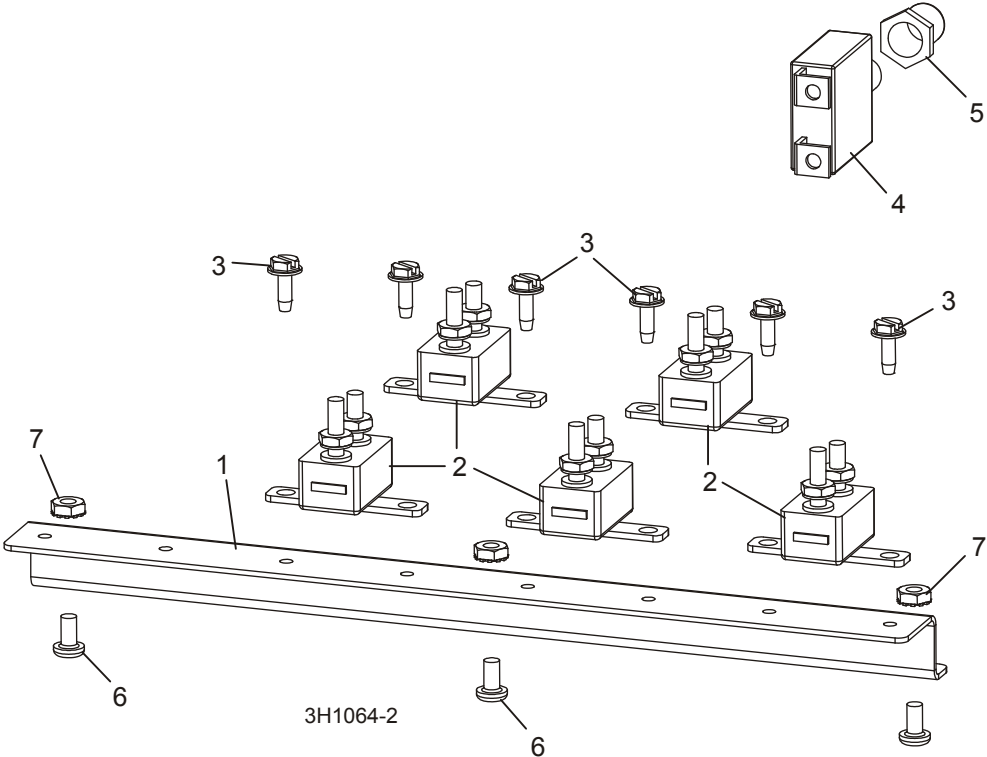

REF	DESCRIPTION (◆ Indicates Parts Available In Assemblies Only)	PART #	QTY.
	BREAKER ASSEMBLY, SAWMILL CONTROL CIRCUIT	015621	1
1	Rail, Circuit Breaker	052826	1
2	Breaker, 15 Amp Manual Reset	E20430	5
3	Screw, #10-24 x 1/2" Self-Tapping	F05015-7	6
4	BREAKER, 70 AMP MANUAL RESET PANEL MOUNT	015527	1
5	BOOT, CIRCUIT BREAKER	021253	1
6	SCREW, #10-24 X 3/8" PHILLIPS PAN HEAD	F05004-3	3
7	NUT, #10-24 SELF LOCKING	F05010-14	3

7.5 Circuit Breakers

LT40 Super

Rev. J7.03 - J7.04

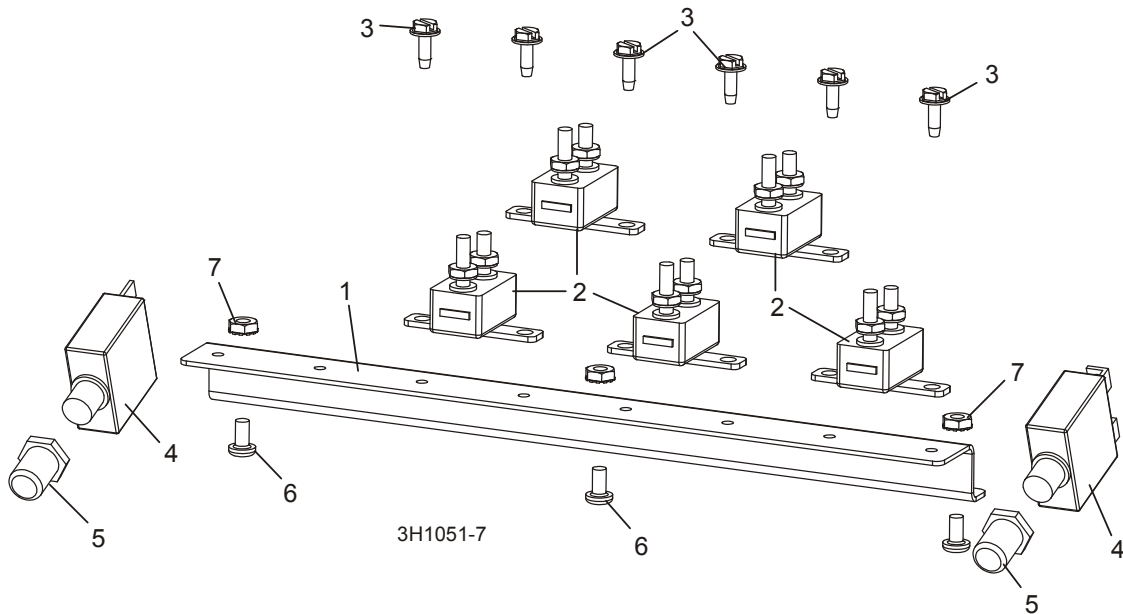

REF	DESCRIPTION (◆ Indicates Parts Available In Assemblies Only)	PART #	QTY.
	BREAKER ASSEMBLY, SAWMILL CONTROL CIRCUIT	015621	1
1	Rail, Circuit Breaker	052826	1
2	Breaker, 15 Amp Manual Reset	E20430	5
3	Screw, #10-24 x 1/2" Self-Tapping	F05015-7	6
4	BREAKER, 70 AMP MANUAL RESET PANEL MOUNT	015527	2
5	BOOT, CIRCUIT BREAKER	021253	2
6	SCREW, #10-24 X 3/8" PHILLIPS PAN HEAD	F05004-3	3
7	NUT, #10-24 SELF LOCKING	F05010-14	3

7.6 Front Panel Assembly & Harnesses

LT40 Super

Rev. J7.05+

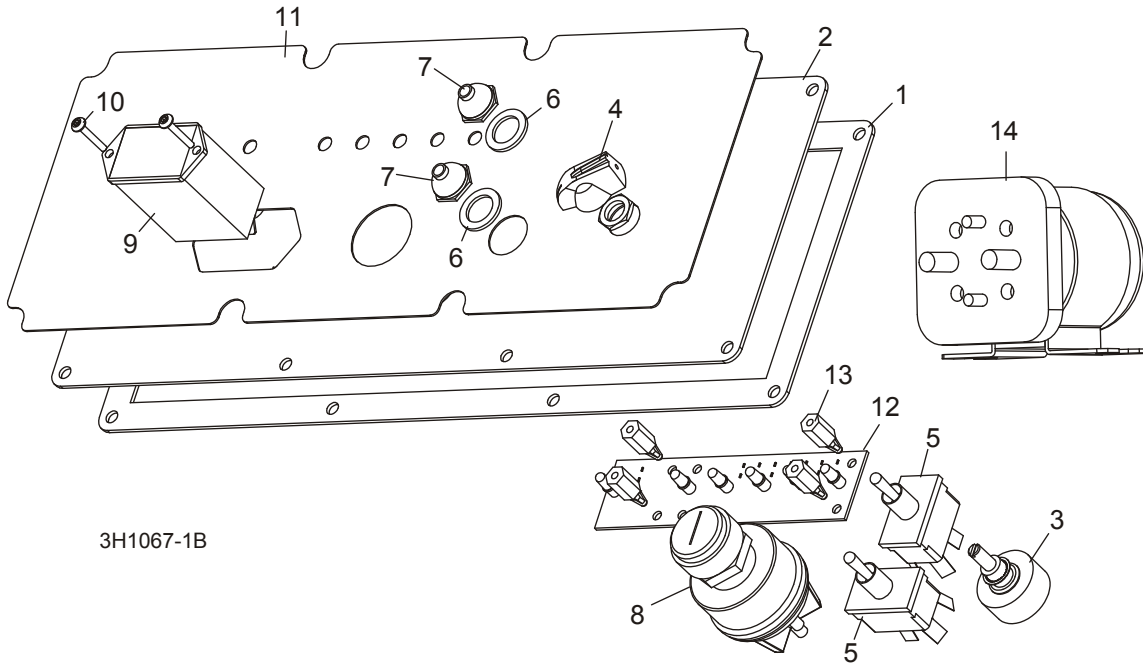

3H1067-1B

REF	DESCRIPTION (◆ Indicates Parts Available In Assemblies Only)	PART #	QTY.
	PANEL ASSEMBLY, CONTROL FRONT (E25)	069417	1
	PANEL ASSEMBLY, CONTROL FRONT (D47) (EXPORT ONLY)	069416	1
1	Gasket, Front Panel	015270	1
2	Panel Weldment, Control	015302	1
3	Switch Assembly, Feed Rate	024450-1	1
4	Knob, Feed Rate With Set Screw	P06257	1
5	Switch, Toggle	024200	2
6	Boot, Toggle Switch Rubber	P02575	2
7	Washer, 1/2 x 3/4 x 1/16 Nylon	P05251-1	2
8	Switch, Key	P04350	1
9	Meter, Hour	015401	1
10	Screw, #6-32 x 1/2" Plain PH T23	F05015-28	2
11	Decal, Control Panel (E25/E30)	015271	1
	Decal, Control Panel (Diesel)	015269	1
12	Board, LED Circuit (E25/E30)	015416	1
	Board, LED Circuit (Diesel)	015409	1
13	Spacer, 1/2"-#6 Threaded	023147	4
14	Solenoid Kit, 200A 12V SPST Cont. Duty	016371	1
	Solenoid, 200A 12V SPST Cont. Duty	015470	1

7 Control & Battery Boxes

Front Panel Assembly & Harnesses

	Diode Assembly, Solenoid Coil Chassis Gnd	015426	1	
	HARNESS ASSEMBLY, UPPER WIRING (E25 2010)	069343	1	
	HARNESS ASSEMBLY, UPPER WIRING (D47 2010)	069309	1	
	Conduit, 1 1/4" x 58" Flex	050399	1	
	Connector, 1 1/4" Straight Male Metal Conduit	024402	1	
	HARNESS ASSEMBLY, LOWER WIRING	051872	1	
	Conduit, 1/2" Expandable Black	R02374	41 in.	
	Conduit, 1/2" Expandable Black	R02374	42 in.	

7.7 Front Panel Assembly & Harnesses

LT40 Super

Rev. J7.03 - J7.04

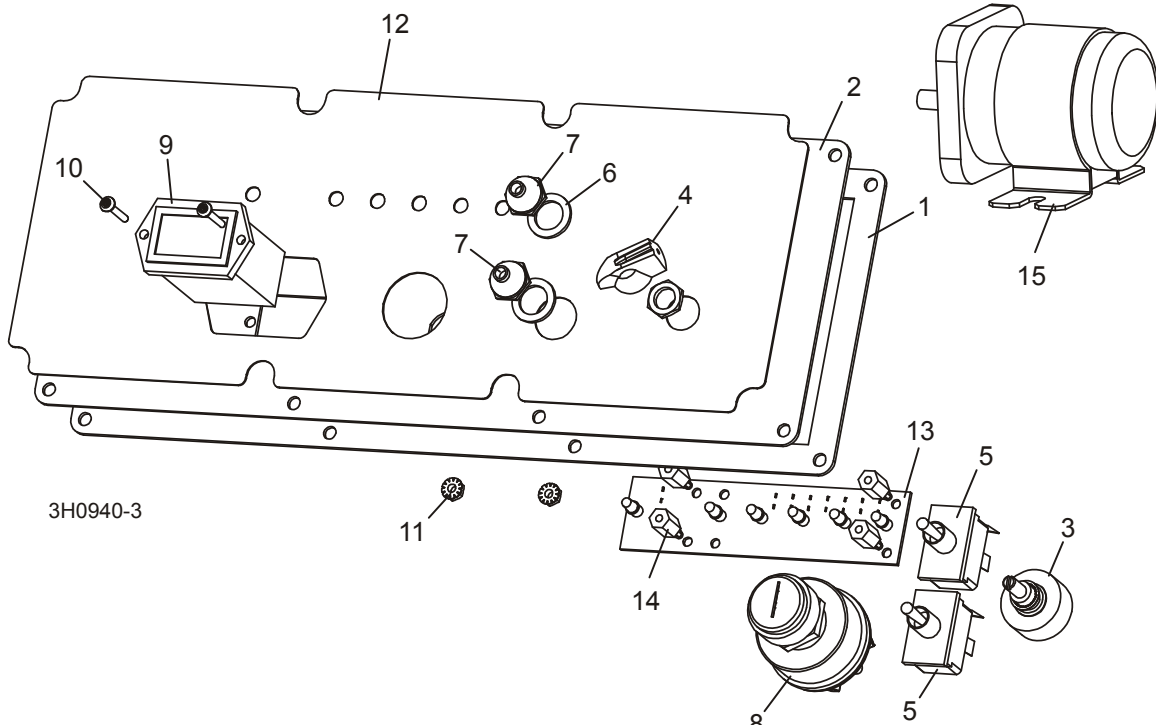

REF	DESCRIPTION (◆ Indicates Parts Available In Assemblies Only)	PART #	QTY.	
	PANEL ASSEMBLY, CONTROL FRONT E25	051875	1	
1	Gasket, Front Panel	015270	1	
2	Panel Weldment, Control	015302	1	
3	Switch Assembly, Feed Rate	024450-1	1	
4	Knob, Feed Rate With Set Screw	P06257	1	
5	Switch, Toggle	024200	2	
6	Boot, Toggle Switch Rubber	P02575	2	
7	Washer, 1/2 x 3/4 x 1/16 Nylon	P05251-1	2	
8	Switch, Key	P04350	1	
9	Meter, Hour	015401	1	
10	Screw, 6-42 x 3/4" Socket Button Head Cap Stainless Steel	F05004-93	2	
11	Nut, 6-32 Self Locking	F05010-59	2	
12	Decal, Control Panel (E25)	015271	1	
13	Board, LED Circuit (E25)	015416	1	
14	Spacer, 1/2"-#6 Threaded	023147	4	
15	Solenoid Kit, 200A 12V SPST Cont. Duty	016371	1	
	Solenoid, 200A 12V SPST Cont. Duty	015470	1	◆
	Diode Assembly, Solenoid Coil Chassis Gnd	015426	1	

7 Control & Battery Boxes

Front Panel Assembly & Harnesses

	Fuse Assembly, 2004 ATO w/Holder	051871	1	
	Fuse, 4A ATO Blade Pink	024150-4	1	
	HARNES ASSEMBLY, UPPER WIRING (E25 2010)	069343	1	
	Conduit, 1 1/4" x 58" Flex	050399	1	
	Connector, 1 1/4" Straight Male Metal Conduit	024402	1	
	HARNES ASSEMBLY, LOWER WIRING	051872	1	
	Conduit, 1/2" Expandable Black	R02374	41 in.	
	Conduit, 1/2" Expandable Black	R02374	42 in.	

7.8 Battery Box Assembly

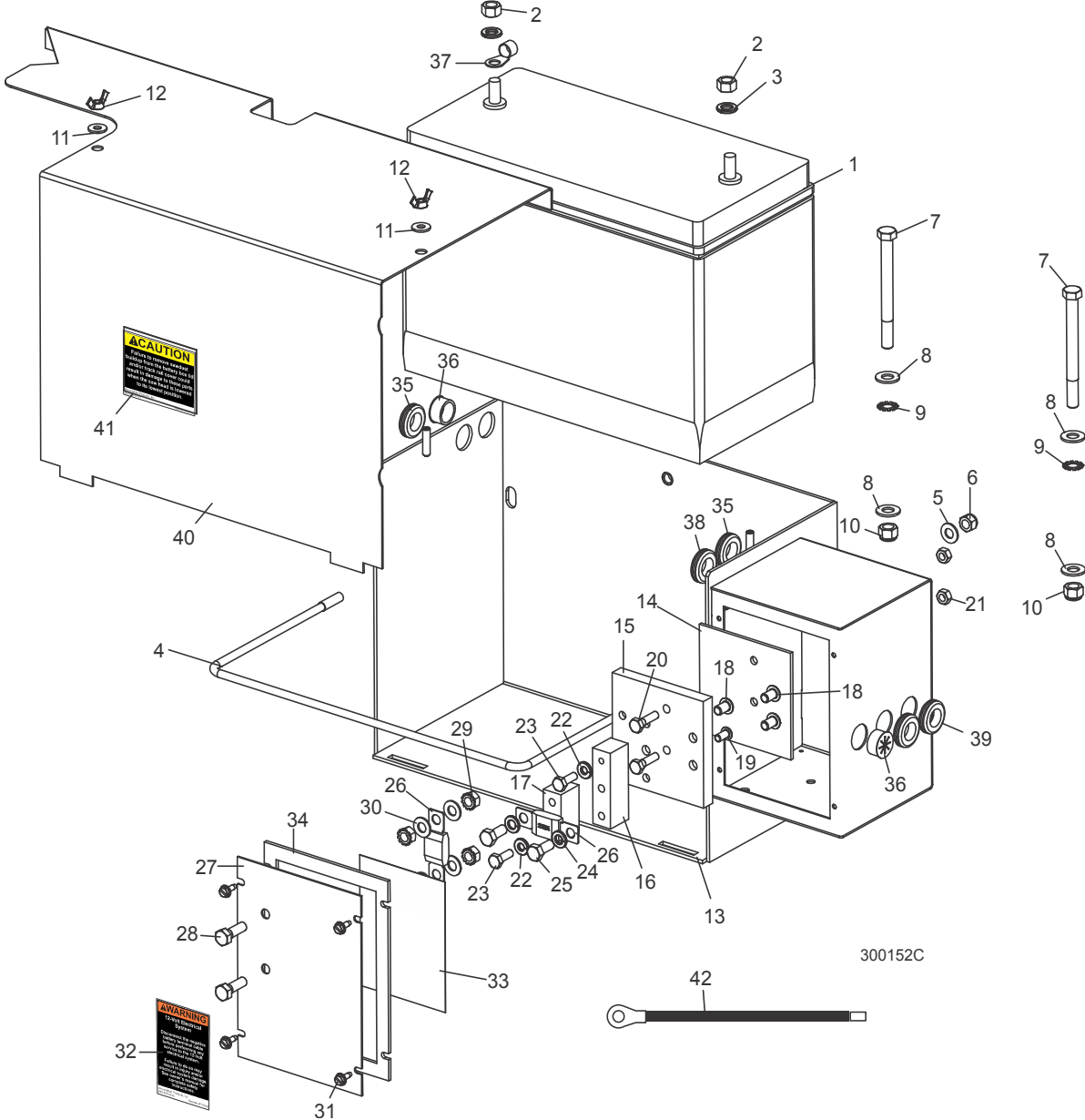

REF	DESCRIPTION (◆ Indicates Parts Available In Assemblies Only)	PART NUMBER	QTY.	
1	BATTERY, 12 VOLT 8A31DTM AGM	025841 ¹	1	◆
	BOX ASSEMBLY, LT30/LT40 SUPER BATTERY	015476 ²	1	
2	Nut, 3/8-16 Hex	F05010-1	2	
3	Washer, 3/8" Split Lock	F05011-4	2	
4	Retainer Loop, Battery	015194	1	
5	Washer, 5/16" SAE Flat	F05011-17	2	

7 Control & Battery Boxes

Battery Box Assembly

6	Nut, 5/16-18 Hex Nylon Lock	F05010-58	2	
7	Bolt, 3/8-16 X 4" Hex Head Grade 2	F05007-4	2	
8	Washer, 3/8" SAE Flat	F05011-3	4	
9	Washer, 3/8" External Star	F05011-36	2	
10	Nut, 3/8" Hex Nylon Lock	F05010-10	2	
11	Washer, 1/4" SAE Flat	F05011-11	2	
12	Nut, 1/4-20 Wing	F05010-13	2	
13	Box Weldment, Battery	015191	1	
	Block Assembly, Single Fuse	006850	1	
14	Plate, Fuse Block Insulator	056999	1	
15	Block, Fuse Mount	056997	1	◆
16	Block, 3/4" Upper Fuse	056996	1	
17	Block, 3/4" Lower Fuse	056998	1	
18	Screw, 5/16-18 x 1/2" Socket Button Head	F05006-20	3	
19	Screw, 1/4-20 x 1/2" Socket Button Head	F05005-59	1	
20	Bolt, 1/4-20 x 1" Hex Head Grade 5	F05005-101	2	
21	Nut, 1/4-20 Hex Lock	F05010-21	2	
22	Washer, 1/4" Split Lock	F05011-14	2	
23	Bolt, 1/4-20 x 3/4" Hex Head Grade 5	F05005-123	2	
24	Washer, 5/16" Split Lock	F05011-13	2	
25	Bolt, 5/16-18 x 3/4" Hex head Grade 5	F05006-102	2	
26	Fuse, 225A 32V Mega	053339	2	
	Plate Assembly, Fuse Box Cover	006854	1	
27	Cover, Fuse Box	006851	1	
28	Bolt, 5/16-18 x 1" Hex Head	F05006-1	2	
29	Nut, 5/16-18 Hex Self-Locking	F05010-20	4	
30	Washer, 5/16" SAE Flat	F05011-17	4	
31	Screw, #10-24 X 1/2" Self-Tapping	F05015-7	4	
32	Decal, 12 Volt Warning	P10364	1	
33	Decal, 225A Mega Fuse Link ID	006866	1	
34	Gasket, Fuse Box Cover	050283	1	
35	Grommet, 5/8" Rubber Wire	P11764	2	
36	Grommet, 5/8" Wire	P04137	2	
37	Terminal, 3/8 1-2 Ga Ring NI Loose	F05092-28	2	
38	Grommet, 3/4" ID 11 Gauge Thickness	074198	2	
39	Grommet, 3/4" ID 16 Gauge Thickness	074199	2	
40	LID WELDMENT, BATTERY BOX SUPER	015771	1	
41	DECAL, BATTERY BOX LID CAUTION	014774	1	
42	CABLE ASSEMBLY, 1 GA X 12" FUSE TO BATTERY POSITIVE	036308	1	

¹ Replaces 12 Volt Battery (015475) supplied prior to Rev. J7.09. 12 Volt Battery (015475) changed to be equipped with one threaded stud (5/11).

² Battery terminals (P05085), washer (P12161), 1/4" exterior star washer (F05011-37) and 1/4-20 hex self-locking nut (F05010-9) replaced with ring terminals and fasteners for batteries with threaded studs (5/11).

SECTION 8 UP/DOWN SYSTEM

8.1 Saw Head Mount

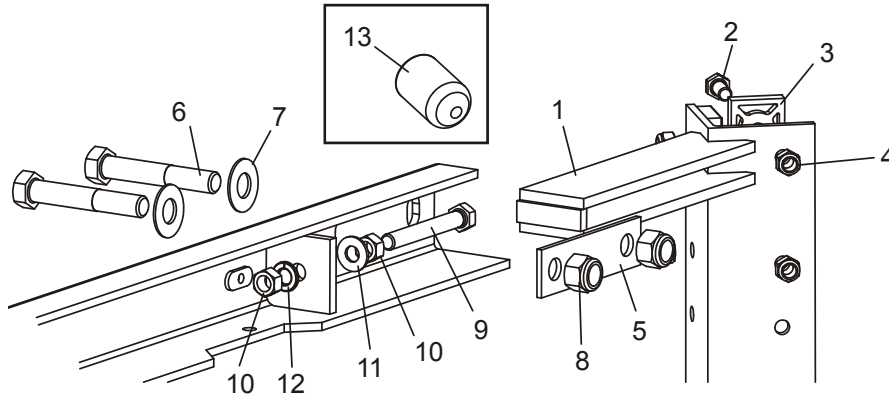

SM0080D

REF	DESCRIPTION (◆ Indicates Parts Available In Assemblies Only)	PART #	QTY.
1	V-BRACE, SAW HEAD MOUNT	W04099	1
2	BOLT, 5/16-18 X 3/4" HEX HEAD GRADE 5	F05006-5	12
	BOLT, 5/16-18 X 1 1/4 HEX HEAD FULL THREAD GRADE 5	F05006-93	4
3	PAD, PLASTIC SLIDE	M04096	6
	PAD, PLASTIC SLIDE LOWER W/CHAMFER	016241	2
4	NUT, 5/16-18 NYLON LOCK	F05010-58	16
5	PLATE, V-BRACE WASHER	S07935	2
6	BOLT, 1/2-13 X 3 1/2" HEX HEAD GRADE 5	F05008-61	4
7	WASHER, 1/2" SAE FLAT	F05011-2	4
8	NUT, 1/2-13 NYLON LOCK	F05010-8	4
9	BOLT, 3/8-16 X 2" FULL THREAD	F05007-17	2
10	NUT, 3/8-16 HEX	F05010-1	4
11	WASHER, 3/8" SAE FLAT	F05011-3	2
12	WASHER, 3/8" SPLIT LOCK	F05011-4	2
13	CAP, .281" X 1/2" BLACK VINYL	017715	3

8.2 Blade Height & Quarter Scales

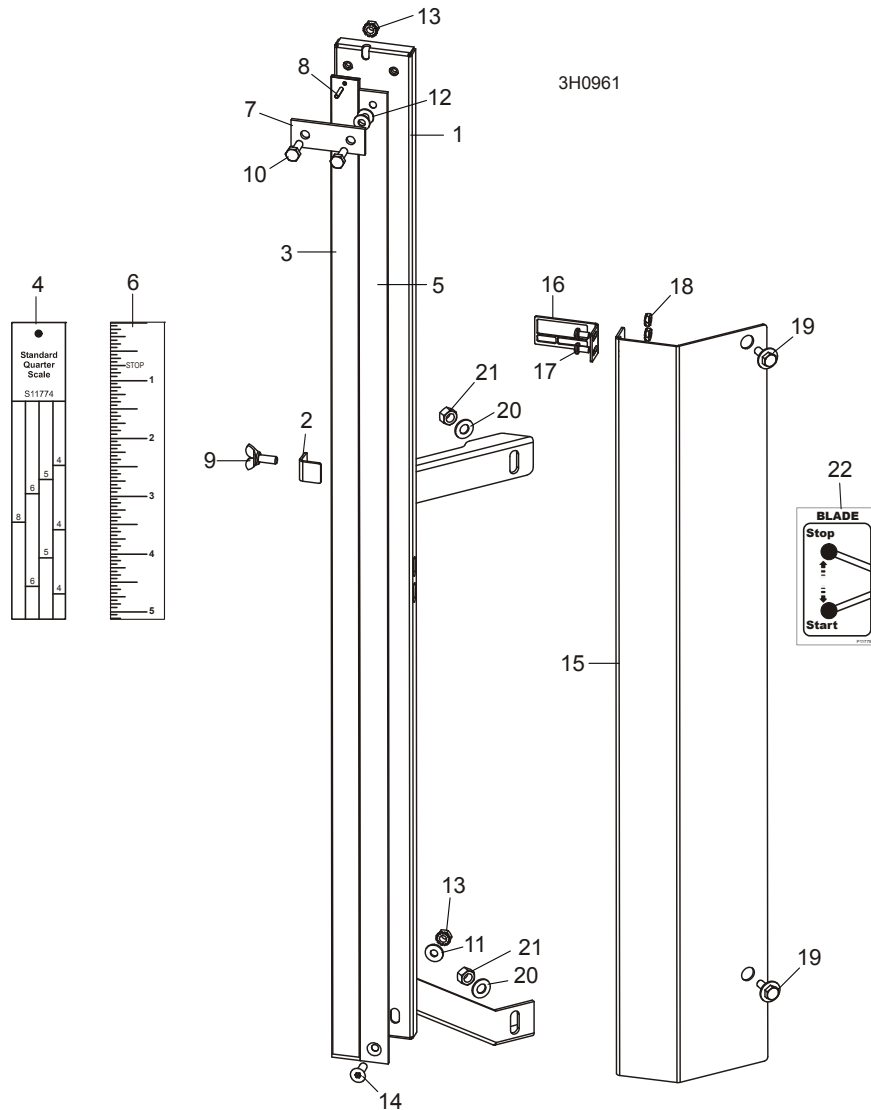

REF	DESCRIPTION (◆ Indicates Parts Available In Assemblies Only)	PART #	QTY.	
	SCALE RETROFIT, FIXED WITH POINTER	A12030	1	
	Scale Kit, Fixed With Pointer	K11998	1	◆
	Scale Assembly, Fixed	A12022	1	◆
1	Bracket, Scale Mounting	W11996	1	
2	Plate, Movable Scale Stop	036666	1	
3	Scale, 35" Quarter	S11989	1	
4	Decal, 35" Standard Quarter Scale	S11774	1	
	Decal, 35" Grade Hardwood Quarter Scale	P12819	1	
5	Scale, 35" Inch	S11988	1	
6	Decal, 35" Inch	S11773	1	
7	Strap, Scale Hold-Down	S04805	1	

Saw Head Mount & Scales

Blade Height & Quarter Scales

8

8	Pin, 1/8" X 5/8" Roll	F05012-14	1	
9	Screw, 1/4-20 X 5/8" Wing	F05005-64	1	
10	Bolt, 1/4-20 x 1/2" Hex Head	F05005-1	2	
11	Washer, 1/4" SAE Flat	F05011-11	1	
12	Washer, 1/4" X .020 Thick Nylon Flat	F05011-22	2	
13	Nut, 1/4-20 Hex Self-Locking	F05010-9	2	
14	Screw, 1/4-20 X 3/4" Flat Socket Head	F05005-70	1	
	Pointer Assembly, Fixed Scale	038591	1	
15	Bracket, Fixed Scale Pointer Mount	038586	1	
16	Pointer, Fixed Scale	038585	1	
17	Screw, #10-24 X 3/8" Phillips Head	F05004-3	2	
18	Nut, #10-24 Hex Self-Locking	F05010-14	2	
19	Bolt, 1/4-20 x 3/4" with Conical Washer	F05005-134	2	
20	Washer, 5/16" SAE Flat	F05011-17	2	
21	Nut, 5/16-18 Hex Lock	F05010-6	2	
	Bolt, 1/4-20 X 1/2" Hex Head Grade 2	F05005-15	1	
	Instruction Sheet, Fixed Scale Retrofit	A12030-370	1	
	DECAL KIT, METRIC SCALE	K12064	1	
	Decal, Metric	S11711	1	
	Decal, Metric 16-40mm	P12040-1	1	
	Decal, Metric 45-63mm	P12040-2	1	
22	DECAL, CLUTCH HANDLE OPERATION	P11779	1	

8.3 Up/Down Chain & Sprockets

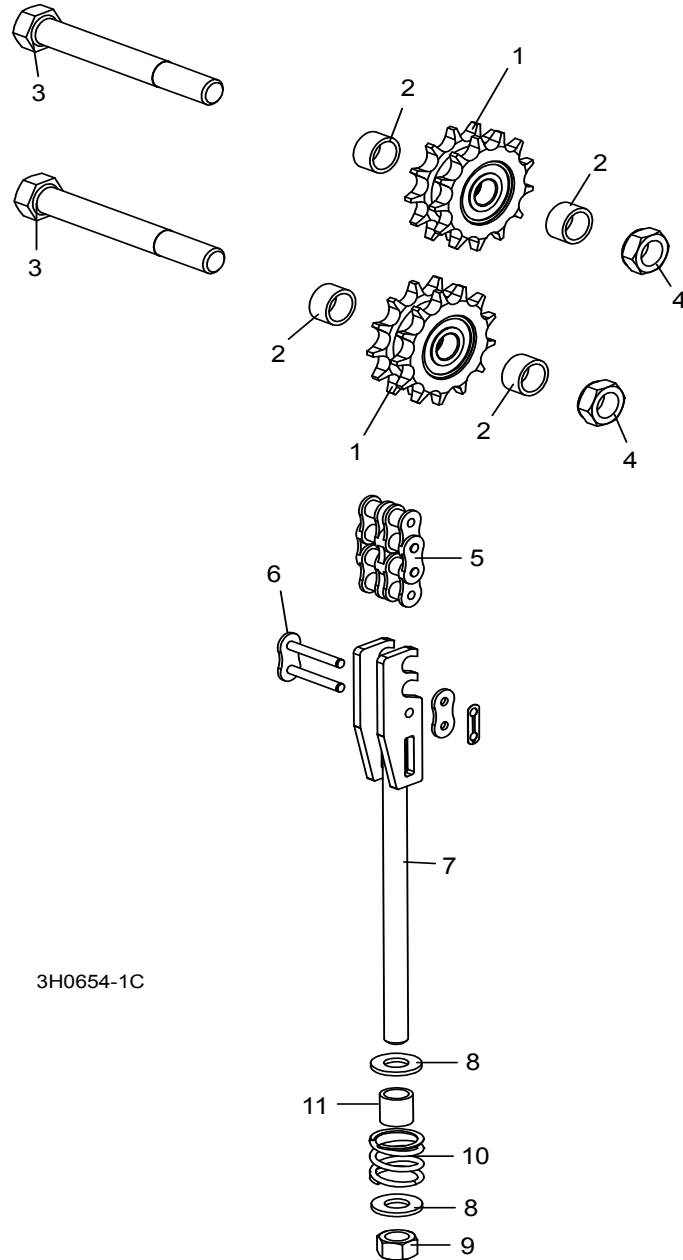

REF	DESCRIPTION (◆ Indicates Parts Available In Assemblies Only)	PART #	QTY.
	SPROCKET KIT, UP/DOWN IDLER #50-2	016020	1
1	Sprocket, Up/Down Idler '98	016019	2
2	Spacer, 50-2 Idler '98	016018	4
	Instruction Sheet, Up/Down Idler Retrofit	016020-541	1
3	BOLT, 5/8-11 X 5" HEX HEAD GRADE 2	F05009-6	2

4	NUT, 5/8-11 JAM NYLON LOCK	F05010-96	2	
5	CHAIN, #50-2 X 75.625" UP/DOWN	015259	1	
6	LINK, #50-2 MASTER	015258	2	
	TENSIONER ASSEMBLY, UP/DOWN CHAIN	015456	1	
7	Bracket, Up/Down #50 Chain Tensioner	015188	1	◆
8	Washer, 1/2" SAE Flat	F05011-2	2	
9	Nut, 1/2-13 Hex Nylon Lock	F05010-8	1	
10	Spring, 1" OD x 1" Long x .125" Wire Compression	016516	1	
11	Spacer, Up/Dn Chain Tensioner	016515	1	

8.4 Up/Down Motor Assembly

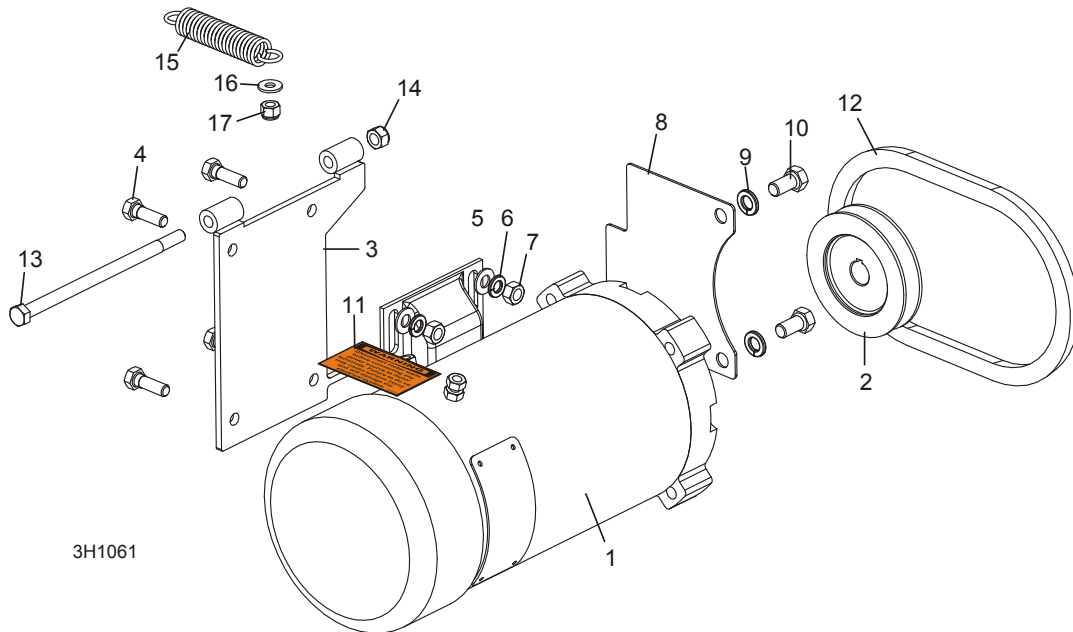

REF	DESCRIPTION (◆ Indicates Parts Available In Assemblies Only)	PART #	QTY.	
	UP/DOWN MOTOR ASSEMBLY	008779	1	
1	Motor, 1HP 12VDC Electric	053682	1	
	Brush Kit, Leeson 1HP Motor	053682-BK	1	
2	Pulley, AK32 x 5/8"	008999	1	
3	Bracket, Up/Down Motor Mount	015198	1	
4	Bolt, 5/16-18 x 1" Hex Head	F05006-1	4	
5	Washer, 5/16" SAE Flat	F05011-17	4	
6	Washer, 5/16" Split Lock	F05011-13	4	
7	Nut, 5/16-18 Hex	F05010-17	4	
8	Guard, Up/Down Sprocket	015016	1	
9	Washer, 3/8" Split Lock	F05011-4	2	
10	Bolt, 3/8-16 x 3/4" Hex Head	F05007-27	2	
11	Decal, Disconnect Motor Leads Warning	024431	1	
12	BELT, 4L245 NOTCHED	038459	1	
13	BOLT, 5/16-18 X 6" HEX HEAD GRADE 5	F05006-73	1	
14	NUT, 5/16-18 HEX NYLON LOCK	F05010-65	1	
15	SPRING, .75" X 3 3/4" X .092" EXTENSION	015569	1	
16	WASHER, 1/4" SAE FLAT	F05011-11	1	
17	NUT, 1/4-20 NYLON LOCK HEX	F05010-69	1	

8.5 Up/Down Drive Assembly

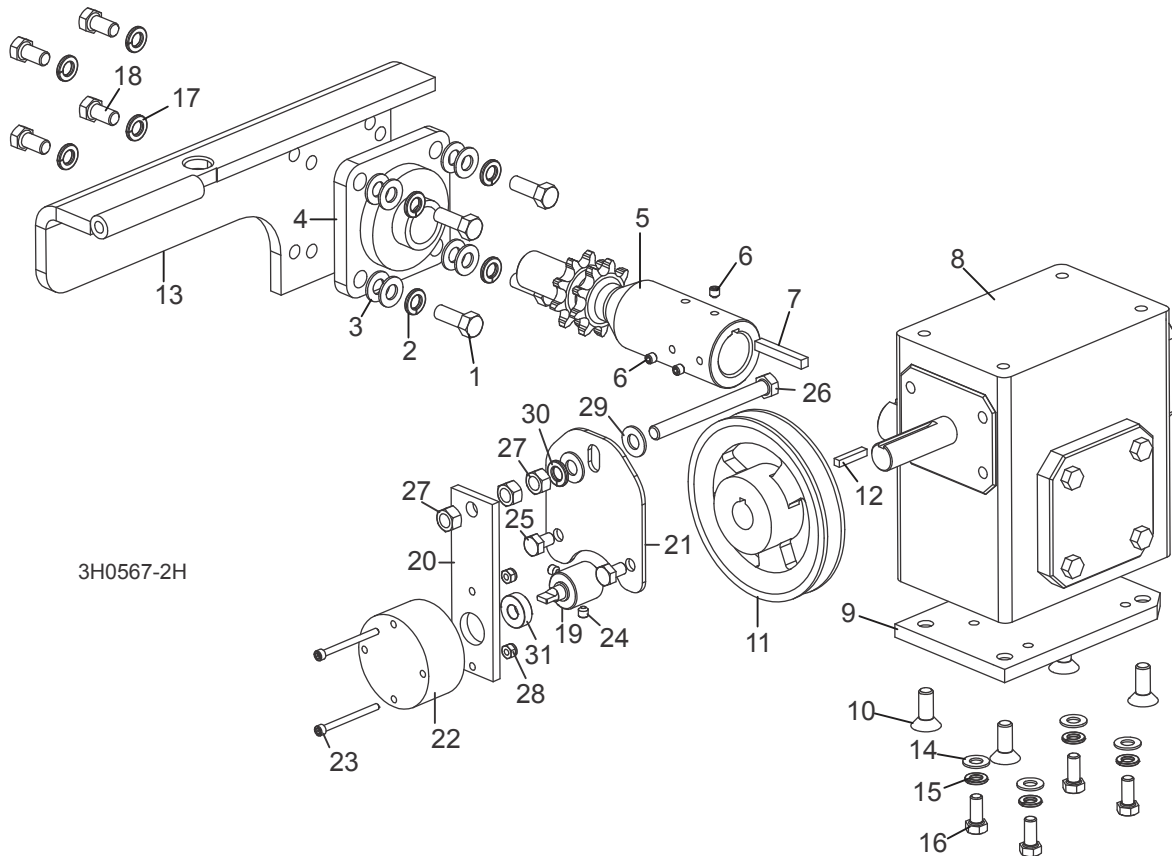

REF	DESCRIPTION (◆ Indicates Parts Available In Assemblies Only)	PART #	QTY.
	UP/DOWN DRIVE ASSEMBLY	015176	1
1	Bolt, 3/8-16 x 1" Hex Head	F05007-7	4
2	Washer, 3/8" Split Lock	F05011-4	4
3	Washer, 3/8" SAE Flat	F05011-3	8
4	Bearing, Flanged Up/Down	014090	1
	Shaft Kit, Up/Down Drive	016094	1
5	Shaft, Up/Down Sprocket	016031	1 ◆
6	Screw, 1/4-28 x 1/4" Socket Head Cup Point	F05005-105	3
7	Key, 1/4" Square x 1 11/16" Long	S04124	1
8	Gear Box, Up/Down Grove	074124 ¹	1
9	Plate, Gear Box Spacer	014158	1
10	Bolt, 3/8-16 x 1" Flat Socket Head	F05007-64	4
11	Pulley, Up/Down	015256	1
12	Key, 3/16" Square x 1" Long	S31027	1
13	Bracket, Up/Down Motor Mount	015195	1
14	WASHER, 5/16" SAE FLAT	F05011-17	4

8

Up/Down System

Up/Down Drive Assembly

15	WASHER, 5/16" SPLIT LOCK	F05011-13	4	
16	BOLT, 5/16-18 X 3/4" HEX HEAD GRADE 5	F05006-102	4	
17	WASHER, 3/8" SPLIT LOCK	F05011-4	4	
18	BOLT, 3/8-16 X 3/4" HEX HEAD	F05007-27	4	
	OIL, 8 OZ. MOBIL SHC634 BOTTLED SYNTHETIC GEAR	L04869-4 ²	1	
	BRAKE ASSEMBLY, SUPER UP/DOWN	065187 ³	1	
19	Shaft, Up/Down Brake LT70 3/4"	062511 ⁴	1	
20	Plate, Brake Mount	062513	1	
21	Plate, Super Up/Down Brake Mount	065190	1	
	Brake Assembly, LT40/50/70 Up/Down Replacement	065907	1	
22	Brake, Klauber Gearmotor #K01134D300	069519	1	◆
	Terminal, 3/16" 18-22 Ga Quick Male	F05708-26	2	
23	Bolt, #8-32 x 2" Socket Head Stainless Steel	F05004-273	2	
24	Screw, 1/4-20 x 1/4" Cup Point Socket Set	F05005-131	2	
25	Bolt, 5/16-18 x 1/2" Hex Head Grade 5	F05006-15	2	
26	Bolt, 3/8-16 x 4" Hex Head Full Thread Grade 5	F05007-92	1	
27	Nut, 3/8-16 Hex	F05010-1	3	
28	Nut, #8-32 Hex Nylon Lock	F05010-169	2	
29	Washer, 3/8" SAE Flat	F05011-3	2	
30	Washer, 3/8" Split Lock	F05011-4	1	
31	Bearing, R6-2NSL SRI-2 ABEC-1	P10688	1	
	Diode OR Assembly, Up/Down Brake LT40/50	069678-S-FR	1	

¹ Replaces 014074 Gear Box Reducer to help eliminate head drift (LT40 Super Rev. J7.13). 074124 Up/Down Grove Gear Box uses thicker Mobil SHC 634 lubricant.

² 24 oz. required for complete oil replacement.

³ Brake added Rev. J7.06 to prevent saw head from drifting during sawing. Use retrofit kit 062570 to retrofit previous revisions.

⁴ Replaced 062567 Shaft, Up/Down Brake on LT40 Super Rev. J7.06, LT40HD Super Rev. K3.05 and LT50 Rev. A5.05. **NOTE:** The up/down brake assembly is mounted on up/down motor on mills prior to those revisions.

SECTION 9 FEED SYSTEM & TRACK ROLLERS

9.1 Upper Track Rollers And Wipers

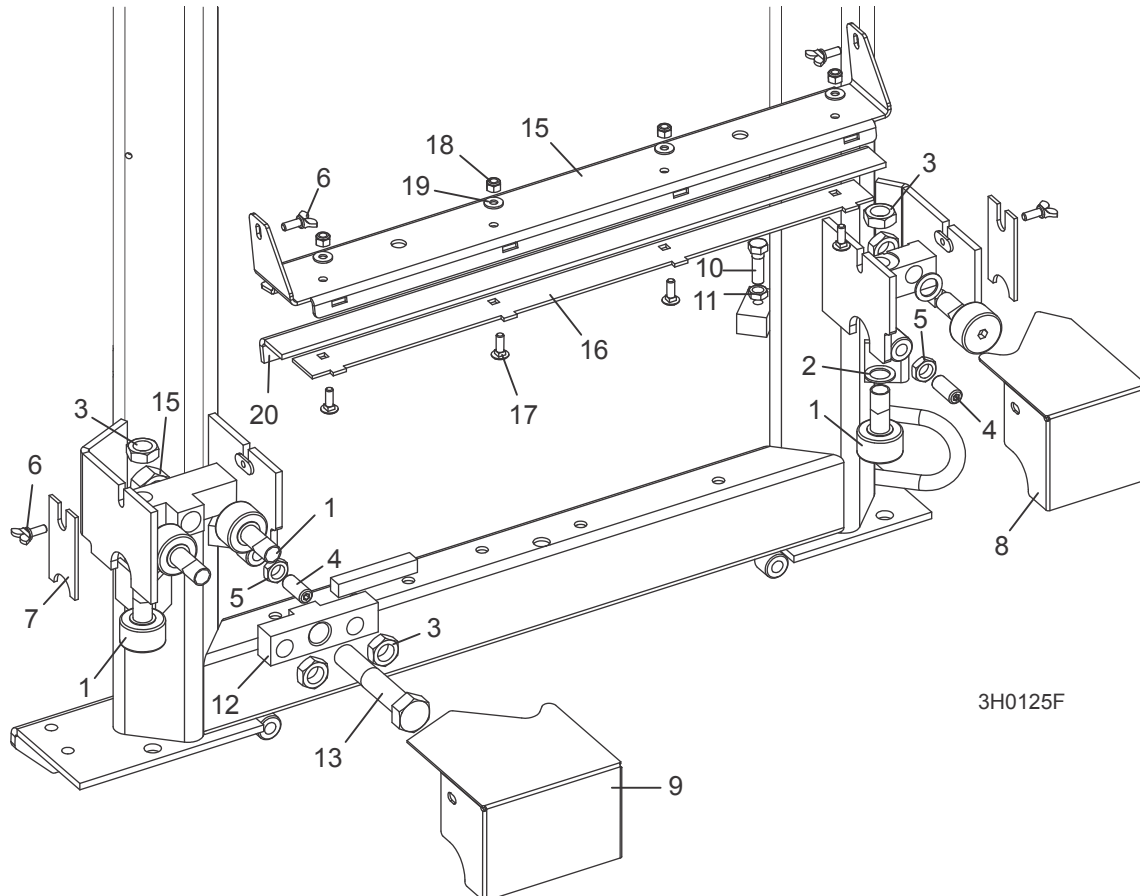

REF	DESCRIPTION (◆ Indicates Parts Available In Assemblies Only)	PART #	QTY.
1	ROLLER, TRACK CAM BEARING	012797	5
2	SHIM, 5/8" X 1" X .062"	016510	2
3	NUT, 5/8-18 HEX JAM	F05010-11	5
4	SCREW, 1/2-13 X 1 1/4" OVAL POINT SET	F05008-5	2
5	NUT, 1/2-13 HEX JAM	F05010-31	2
6	SCREW, 1/4-20 X 5/8" THUMB	F05005-64	4
7	WIPER, PLASTIC TRACK	M04113	2
8	HOUSING, UPPER TRACK ROLLER REAR	012999	1
9	HOUSING, UPPER TRACK ROLLER FRONT	016285	1
10	BOLT, 3/8-16 X 1 1/4" HEX HEAD	F05007-2	2
11	NUT, 3/8-16 HEX JAM	F05010-29	2
12	BLOCK, UPPER ROLLER PIVOT	016501	1
13	BOLT, 3/4-10 X 4" HEX HEAD GRADE 5	F05013-3	1

9

Feed System & Track Rollers

Upper Track Rollers And Wipers

14	NUT, 3/4-10 SELF LOCKING	F05010-80	1	
	COVER ASSEMBLY, LT40 TRACK	110612	1	
15	Cover, Middle Track, LT40	110609	1	◆
16	Retainer, Felt Oiler	110611	1	◆
17	Bolt, 1/4-20x3/4 Carriage	F05005-113	4	
18	Nut, 1/4-20 Nylock	F05010-69	4	
19	Washer, 1/4 SAE Flat	F05011-11	4	
20	Felt, Middle Track Oiler LT40/50/70	S09915	1	

9.2 Power Feed Assembly

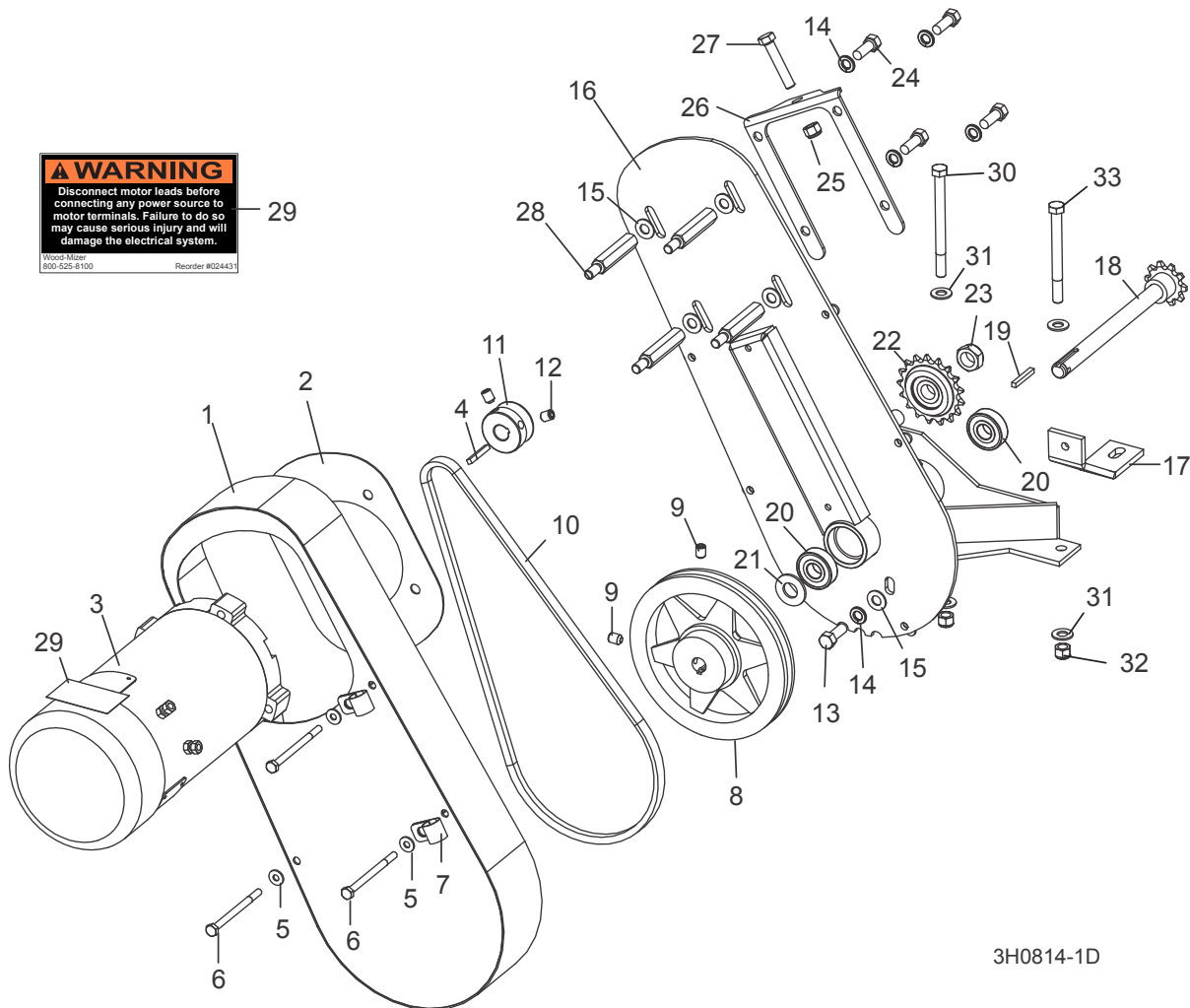

WARNING
Disconnect motor leads before connecting any power source to motor terminals. Failure to do so may cause serious injury and will damage the electrical system.

Wood-Mizer
800-525-8100 Recorder #024431

3H0814-1D

REF	DESCRIPTION (◆ Indicates Parts Available In Assemblies Only)	PART #	QTY.
	POWER FEED ASSEMBLY	015125	1
1	Cover Weldment, Top Power Feed	015126	1
2	Plate, Power Feed Motor	015133	1
3	Motor, 3/4HP Power Feed Painted	024169	1
	Brush Kit, Leeson 3/4HP Motor (Includes 2 Brushes and 2 Springs)	024167	1
	Fan, 3/4 HP Leeson Motor Replacement	016087	1
	Guard, Motor Fan Leeson 3/4HP	061146	1
4	Key, 3/16" Square x 1" Long	S31027	1
5	Washer, 1/4" SAE Flat	F05011-11	4
6	Bolt, 1/4-20 X 3 1/2" Hex Head Grade 2	F05005-54	4
7	Clamp, 5/8" EMT Coated	010748	2

9

Feed System & Track Rollers

Power Feed Assembly

8	Sheave, AK71 x 5/8" Power Feed (200ft./min.)	016088 ¹	1	
9	Screw, 5/16-18 x 3/4" Cup Point Set	F05006-32	2	
10	Belt, AX36 (200ft./min.)	016083 ¹	1	
11	Sheave, 1 3/4" Feed Motor	015135	1	
12	Screw, 3/8"-16 x 1/2" Cup Point Set	F05007-12	2	
13	Bolt, 3/8-16 x 1" Hex Head	F05007-7	1	
14	Washer, 3/8" Split Lock	F05011-4	5	
15	Washer, 3/8" Flat	F05011-3	5	
16	Bracket, Power Feed Mount	015162	1	
17	Brace, Power Feed Mounting	015132	1	
	Shaft Assembly, Power Feed with Key	016066	1	
18	Shaft Weldment, Power Feed	015129	1	◆
19	Key, 3/16" Square x 1 3/8" Long	016108	1	
20	Bearing, 5/8" 6203-2NSL	P06030-1	2	
21	Washer, 5/8" x 15/16" x .094" Nylon	F05011-19	1	
22	Sprocket, #40/41 Idler 17T 5/8" ID w/Bearing	016366	1	
23	Nut, 5/8-11 Nylon Lock Jam	F05010-96	1	
24	Bolt, 3/8-16 x 3/4" Hex Head	F05007-27	4	
25	Nut, 3/8-16 Hex Nylon Lock	F05010-10	1	
26	Plate, Belt Tensioner	015134	1	
27	Bolt, 3/8-16 x 2" Full Thread Hex Head	F05007-16	1	
28	Spacer, Power Feed Motor	015136	4	
29	Decal, Disconnect Motor Leads Warning	024431	1	
30	BOLT, 3/8-16 X 4 1/2" HEX HEAD	F05007-35	1	
31	WASHER, 3/8" SAE FLAT	F05011-3	4	
32	NUT, 3/8-16 HEX NYLON LOCK	F05010-10	2	
33	BOLT, 3/8-16 X 4" FULL THREAD HEX HEAD TAP GRADE 5	F05007-4	1	

¹ To increase feed return rate to 220 ft./min. replace with AK64 sheave 016114 and AX35 belt 015175 (replaces kit 016085). Kit 016070, AL84 x 5/8" Sheave 016115 and AX38 Belt 016068 to reduce feed return rate to 183 ft./min. no longer available.

9.3 Feed Chain/Stop

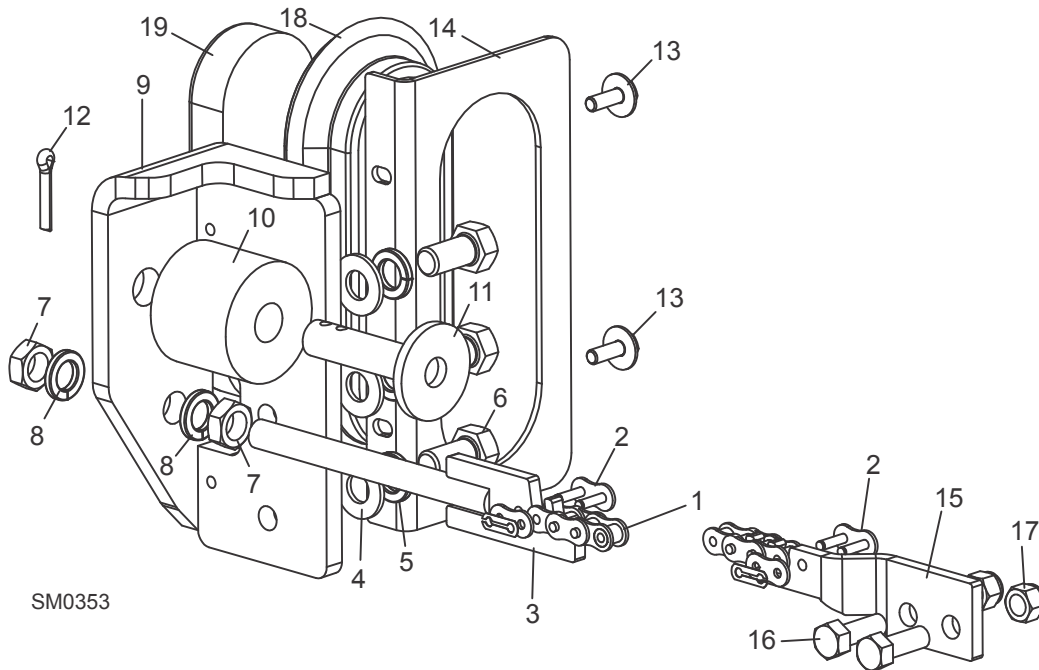

REF	DESCRIPTION (◆ Indicates Parts Available In Assemblies Only)	PART #	QTY.
1	CHAIN, #40 X 215.5" LT30 FEED	014744	1
	CHAIN, #40 X 267.5" LT40 FEED	014745	1
2	LINK, #40 MASTER	P04200	2
3	TENSIONER WELDMENT, POWER FEED CHAIN	015721	1
4	WASHER, 1/2" SAE FLAT	F05011-2	3
5	WASHER, 1/2" SPLIT LOCK	F05011-9	3
6	BOLT, 1/2-13 X 1" HEX HEAD GRADE 8	F05008-128	3
7	NUT, 1/2-20 HEX JAM	F05010-16	2
8	WASHER, 1/2" SPLIT LOCK	F05011-9	2
9	BRACKET WELDMENT, REAR FEED STOP	006686	1
	STOP KIT, RUBBER CARRIAGE	K09630	2
10	Stop, Rubber Carriage	P12165	1
11	Pin, Rubber Carriage Stop	W09293	1
12	Pin, 3/16" X 1" Cotter	F05012-21	1
13	BOLT, 1/4-20 X 3/4" WITH CONICAL WASHER	F05005-134	1
14	PLATE, BED TUBE END W/LIGHT MOUNT	057822	1
15	BRACKET, FRONT FEED CHAIN MOUNT	015008	1
16	BOLT, 3/8-16 X 1" HEX HEAD GRADE 5	F05007-87	2
17	NUT, 3/8-16 HEX NYLON LOCK	F05010-10	2
18	GROMMET, 6 1/2" LIGHT MOUNTING	006688	1
19	LIGHT, 8 DIODE LED TAIL	006391	1

9.4 Lower Track Rollers

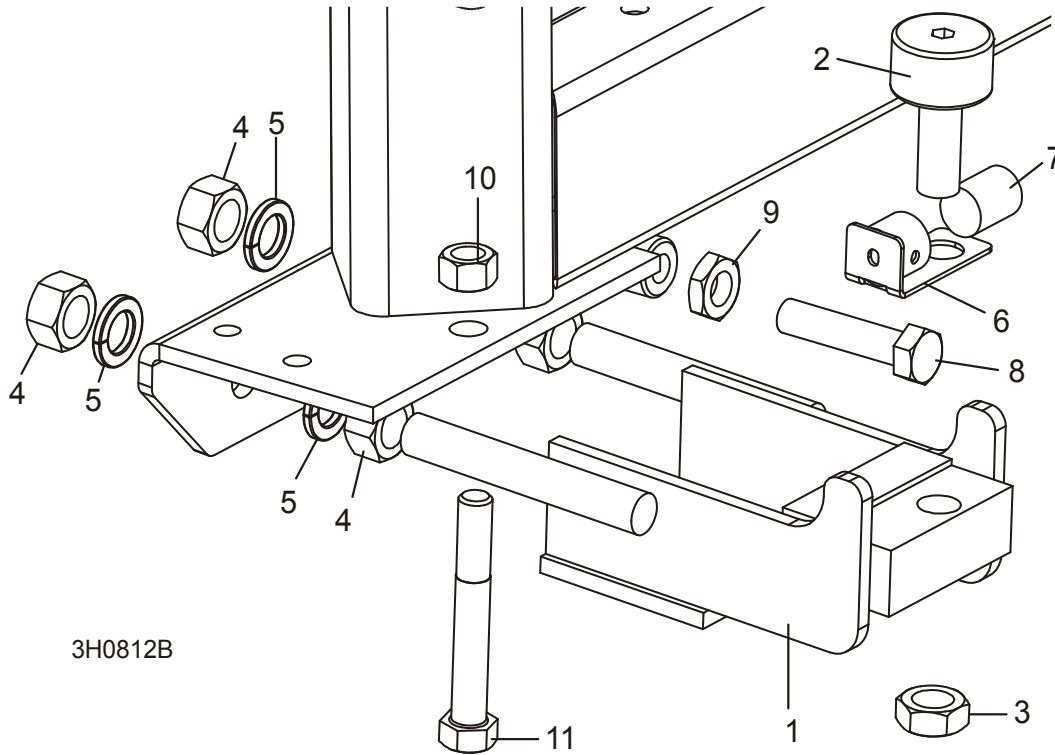

3H0812B

REF	DESCRIPTION (◆ Indicates Parts Available In Assemblies Only)	PART #	QTY.	
	ROLLER ASSEMBLY, LOWER TRACK	012995	2	
1	Bracket, Lower Track Roller Mounting	012982	1	◆
2	Roller, Track Cam Bearing	012797	1	
3	Nut, 5/8-18 Hex Jam	F05010-11	1	
4	Nut, 5/8-11 Hex	F05010-5	4	
5	Washer, 5/8" Split Lock Grade 8	F05011-118	4	
6	Bracket Weldment, Lower Track Roller Wiper	033374	1	
7	Wiper, Round Gray Felt	033375	1	
8	BOLT, 1/2-13 X 2 1/4" HEX HEAD FULL THREAD	F05008-2	2	
9	NUT, 1/2-13 HEX JAM	F05010-31	2	
10	NUT, 1/2-13 HEX LOCK	F05010-3	2	
11	BOLT, 1/2-13 X 3 1/2" HEX HEAD GRADE 5	F05008-61	2	

SECTION 10 BED FRAME ASSEMBLY

10.1 Bed Rail Assembly, Front And Rear

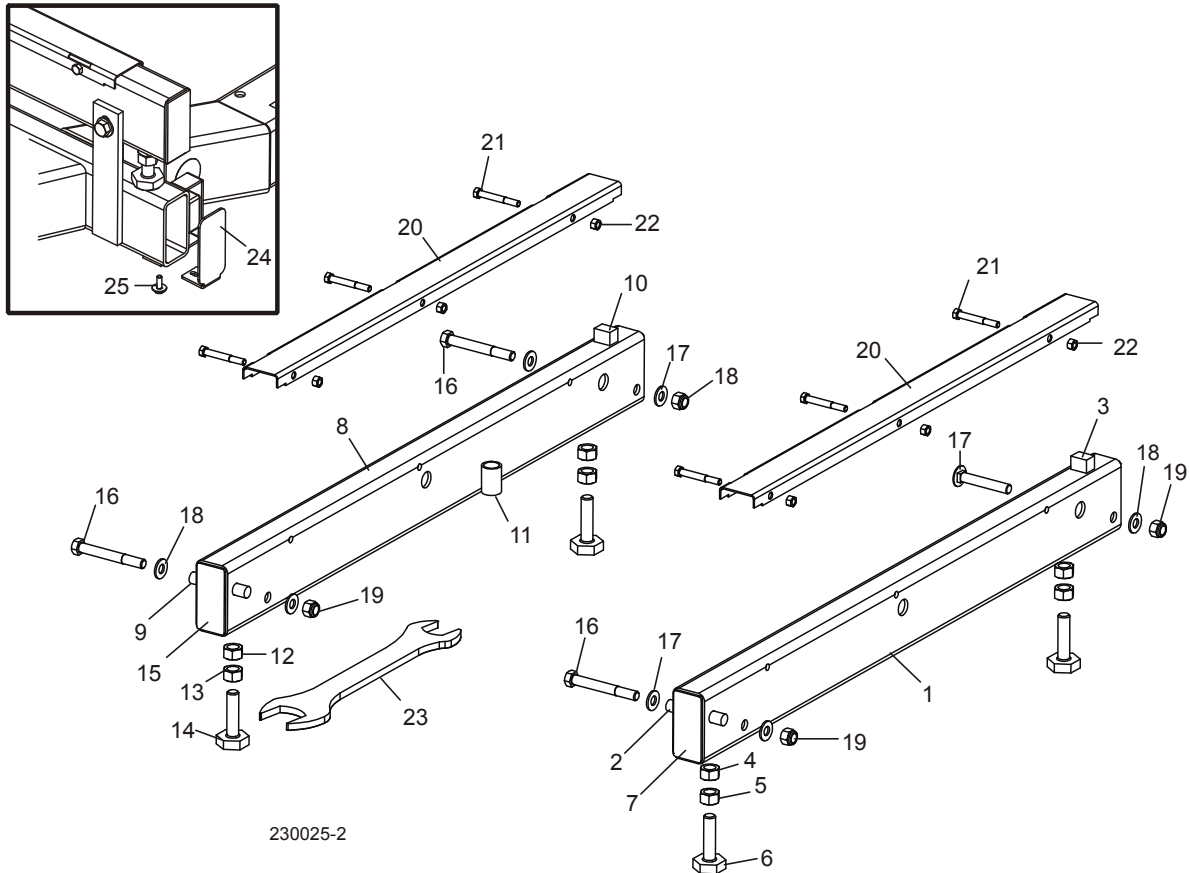

REF	DESCRIPTION (◆ Indicates Parts Available In Assemblies Only)	PART #	QTY.	
	BED RAIL ASSEMBLY, REAR PAINTED	A09774	1	
1	Bed Rail Tube, Long	S09102	1	◆
2	Pin, Ramp Mount	S04030	1	
3	Block, Log Stop	S09034	1	
4	Nut, 5/8-11 Pilot Weld	F05010-84	2	
5	Nut, 5/8-11 Hex	F05010-5	2	
6	Bolt, Bed Rail Adjustment	S13006	2	
7	Plate, Bed Rail End Cap	S04058	2	◆
	BED RAIL ASSEMBLY, FRONT PAINTED	A09564	1	
8	Bed Rail Tube, Long	S09102	1	◆
9	Pin, Ramp Mount	S04030	1	
10	Block, Log Stop	S09034	1	
11	Tube, Ramp Retainer Mount	S09334	1	◆

10

Bed Frame Assembly

Bed Rail Assembly, Front And Rear

12	Nut, 5/8-11 Pilot Weld	F05010-84	2	
13	Nut, 5/8-11 Hex	F05010-5	2	
14	Bolt, Bed Rail Adjustment	S13006	2	
15	Plate, Bed Rail End Cap	S04058	2	◆
16	BOLT, 1/2-13 X 4" HEX HEAD GRADE 5	F05008-78	3	
17	BOLT, 1/2-13 X 3 1/2" CARRIAGE	F05008-94 ¹	1	
18	WASHER, 1/2" SAE FLAT	F05011-2	7	
19	NUT, 1/2-13 NYLON LOCK	F05010-8	4	
	COVER KIT, FRONT/REAR BED RAIL SS	079144	2	
20	Cover, Stainless Steel Bed Rail	016898	1	
21	Bolt, 5/16-18 X 2 1/2" Hex Head	F05006-10	3	
22	Nut, 5/16-18 Hex Lock	F05010-6	3	
23	WRENCH, BED RAIL ADJUSTMENT	015970	1	
24	CAP, BED RAIL REMOVABLE END	038843	2	
25	BOLT, 1/4-20 X 3/4" W/CONICAL WASHER HEAD	F05005-134	2	

¹ Used on rear bed rail to allow clearance for optional side support rollers.

10.2 Bed Rail Assembly, Middle Front

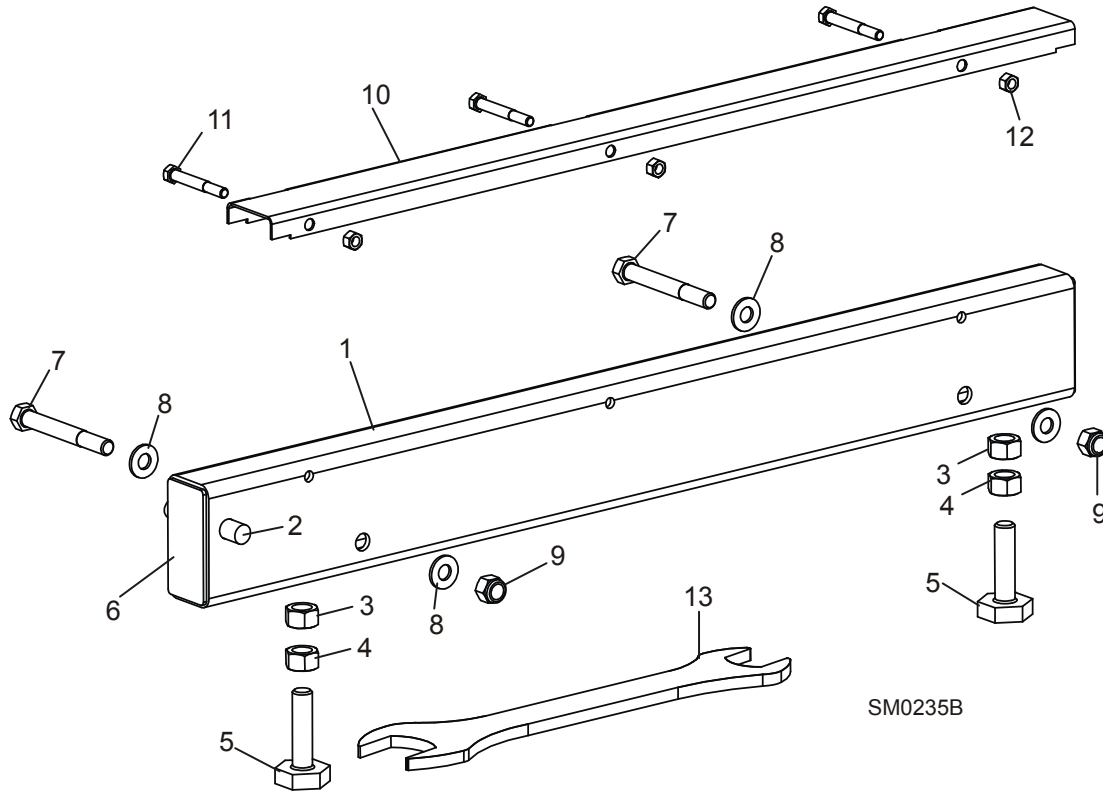

REF	DESCRIPTION (◆ Indicates Parts Available In Assemblies Only)	PART #	QTY.	
	BED RAIL ASSEMBLY, FRONT MIDDLE	A09566	1	
1	Bed Rail Tube, Short	S09103	1	◆
2	Pin, Ramp Mount	S04030	1	
3	Nut, 5/8-11 Pilot Weld	F05010-84	2	
4	Nut, 5/8-11 Hex	F05010-5	2	
5	Bolt, Bed Rail Adjustment	S13006	2	
6	Plate, Bed Rail End Cap	S04058	2	◆
7	BOLT, 1/2-13 X 4" HEX HEAD GRADE 5	F05008-78	2	
8	WASHER, 1/2" SAE FLAT	F05011-2	4	
9	NUT, 1/2-13 NYLON LOCK	F05010-8	2	
	COVER ASSEMBLY, STAINLESS STEEL BED RAIL (LONG)	A09956	1	
10	Cover, Stainless Steel Bed Rail	S09944	1	◆
11	Bolt, 5/16-18 X 2 1/2" Hex Head	F05006-10	3	
12	Nut, 5/16-18 Hex Lock	F05010-6	3	
13	WRENCH, BED RAIL ADJUSTMENT	015970	1	

10

Bed Frame Assembly Bed Rail Assembly, Middle Rear

10.3 Bed Rail Assembly, Middle Rear

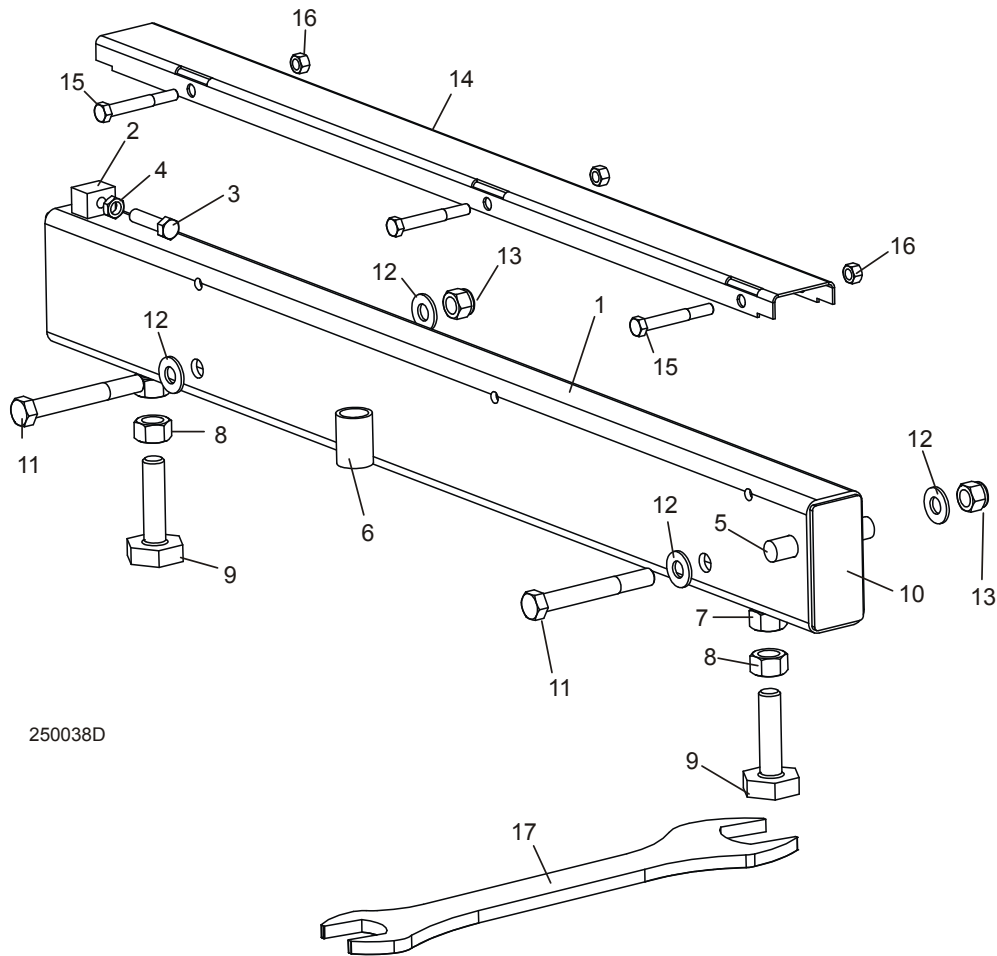

REF	DESCRIPTION (◆ Indicates Parts Available In Assemblies Only)	PART #	QTY.	
	BED RAIL ASSEMBLY, REAR MIDDLE	A09565	1	
1	Bed Rail Tube, Short	014640	1	◆
2	Block, Log Stop w/Threaded Hole	014639	1	◆
3	Bolt, 3/8-16 x 1 1/2 Full Thead Hex Head	F05007-17	1	
4	Nut, 3/8-16 Hex Jam	F05010-29	1	
5	Pin, Ramp Mount	S04030	1	
6	Tube, Ramp Retainer Mount	S09334	1	◆
7	Nut, 5/8-11 Pilot Weld	F05010-84	2	
8	Nut, 5/8-11 Hex	F05010-5	2	
9	Bolt, Bed Rail Adjustment	S13006	2	
10	Plate, Bed Rail End Cap	S04058	2	◆
11	BOLT, 1/2-13 X 4" HEX HEAD GRADE 5	F05008-78	2	
12	WASHER, 1/2" SAE FLAT	F05011-2	4	

Bed Frame Assembly
Bed Rail Assembly, Middle Rear

10

13	NUT, 1/2-13 NYLON LOCK	F05010-8	2	
	COVER ASSEMBLY, STAINLESS STEEL BED RAIL (LONG)	A09956	1	
14	Cover, Stainless Steel Bed Rail	S09944	1	◆
15	Bolt, 5/16-18 X 2 1/2" Hex Head	F05006-10	3	
16	Nut, 5/16-18 Hex Lock	F05010-6	3	
17	WRENCH, BED RAIL ADJUSTMENT	015970	1	

10

Bed Frame Assembly

Leg Assembly (Stationary)

10.4 Leg Assembly (Stationary)

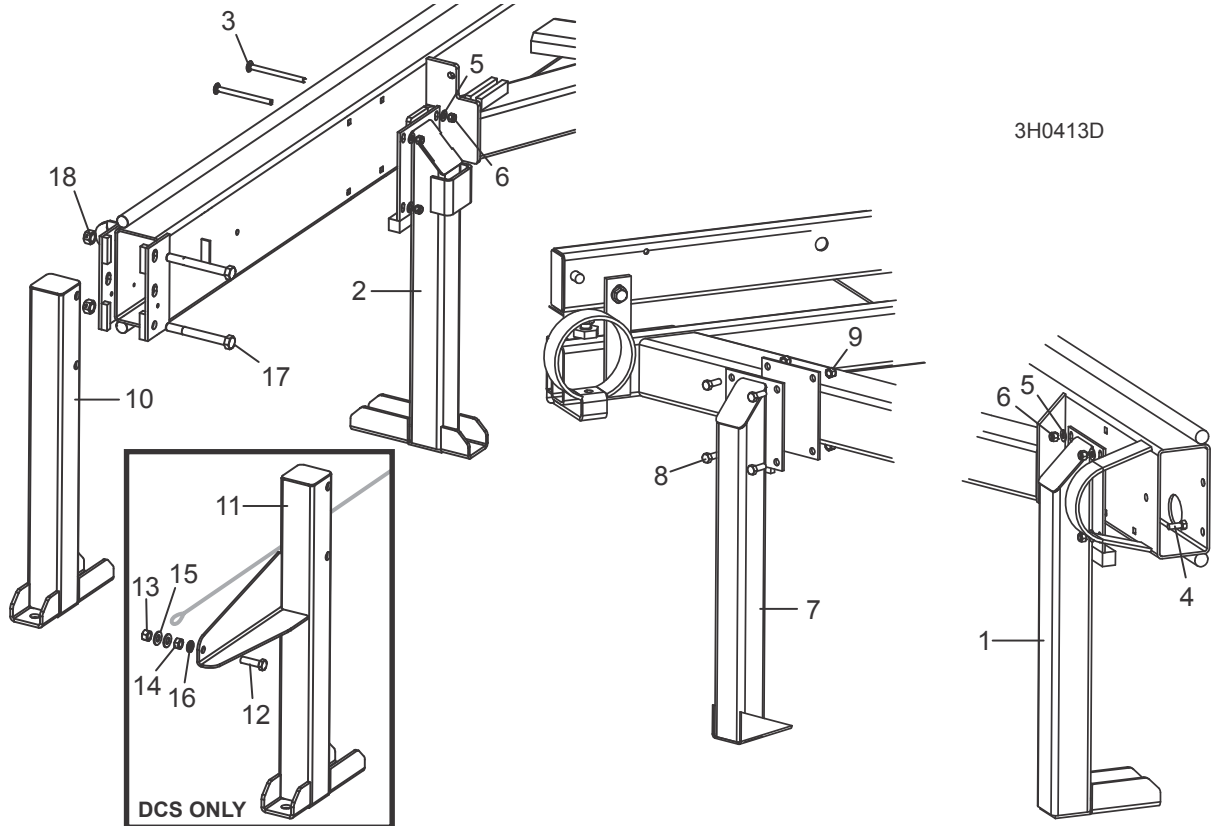

REF	DESCRIPTION (◆ Indicates Parts Available In Assemblies Only)	PART #	QTY.
	See Form #847 or diagram below for stationary sawmill foot anchor locations		
	See Form #359 for stationary sawmill w/bed extension foot anchor locations		
1	LEG, LONG STATIONARY (1 REQ'D FOR LT30; 3 REQ'D FOR LT40)	W09513	1/3
2	LEG, LONG STATIONARY W/BOARD RETURN TABLE BRACKET	O15091	1
3	BOLT, 3/8-16 X 5" CARRIAGE HEAD	F05007-113	8/12
4	BOLT, 3/8-16 X 1 1/4" HEX HEAD (REQ'D FOR REAR LT40 ONLY)	F05007-2	4
5	WASHER, 3/8" SAE FLAT	F05011-3	8/16
6	NUT, 3/8-16 HEX NYLON LOCK	F05010-10	8/16
7	LEG, SHORT STATIONARY	W09515	2
8	BOLT, 3/8-16 X 1 1/4" HEX HEAD	F05007-2	8
9	NUT, 3/8-16 HEX NYLON LOCK	F05010-10	8
10	LEG, FRONT STATIONARY (ALL EXCEPT LT70DCS)	W09517	1
	LEG ASSEMBLY, FESTOON FRONT STATIONARY (LT70DCS ONLY)	O65937	1
11	Leg Weldment, Festoon Stationary Front	O65935	1
12	Bolt, 1/2-13 x 1 3/4" Full Thread Hex Head Grade 5	F05008-88	1
13	Nut, 1/2-13 Swaged Hex	F05010-3	1
14	Nut, 1/2-13 Free Hex	F05010-35	1

15	Washer, 1/2" SAW Flat	F05011-2	2	
16	Washer, 1/2" Split Lock	F05011-9	1	
17	BOLT, 5/8-11 X 5 1/2" HEX HEAD GRADE 5 (ALL EXCEPT LT70DCS)	F05009-11	2	
18	NUT, 5/8-11 HEX LOCK (ALL EXCEPT LT70DCS)	F05010-4	2	

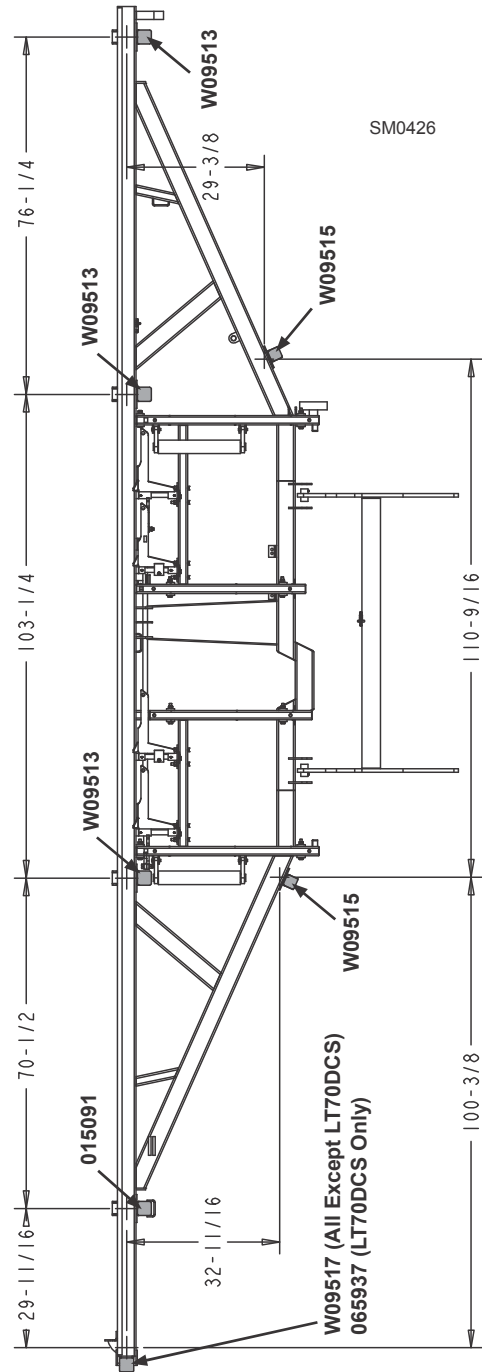
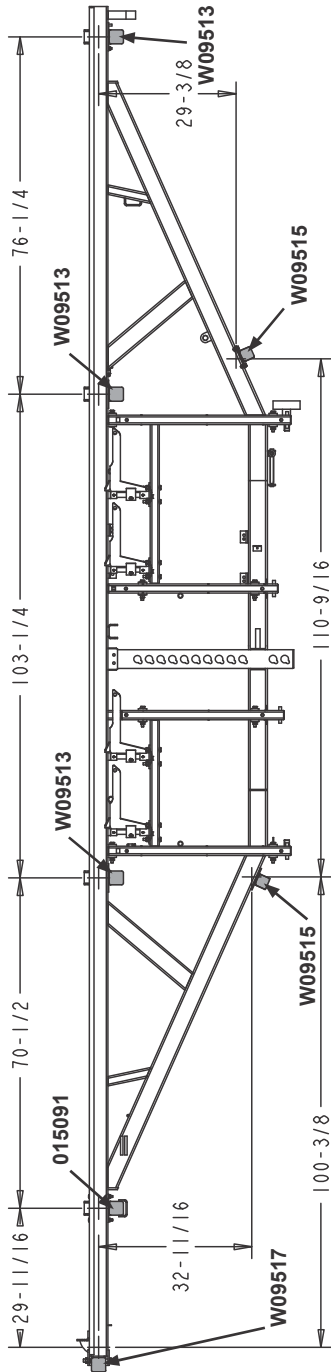

10

Bed Frame Assembly Board Return Table Assembly

10.5 Board Return Table Assembly

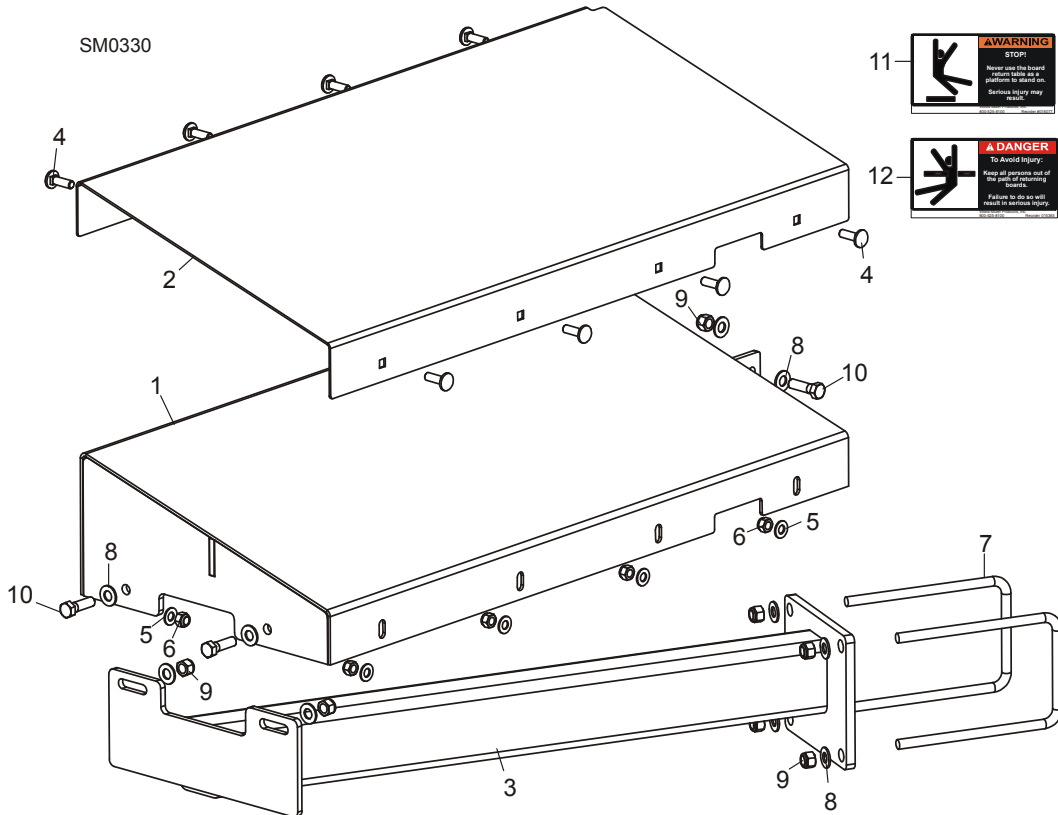

REF	DESCRIPTION (◆ Indicates Parts Available In Assemblies Only)	PART #	QTY.
	TABLE ASSEMBLY, BOARD RETURN (LT40)	003264	1
	TABLE ASSEMBLY, BOARD RETURN (LT30)	003270	1
1	Table Weldment, Board Return	055515	1
2	Cover, Board Return Table	003259	1
3	Mount Weldment, Board Return Table (LT40)	055533	1
	Mount Weldment, Board Return Table (LT30)	038992	1
4	Bolt, 5/16-18 x 1" Carriage Head	F05006-9	8
5	Washer, 5/16" SAE Flat	F05011-17	8
6	Nut, 5/16-18 Nylon Lock	F05010-58	8
7	Bolt, 3/8-16 x 4" x 5" 'U'	003207	2
8	Washer, 3/8" SAE Flat	F05011-3	10
9	Nut, 3/8-16 Hex Nylon Lock	F05010-10	7
10	Bolt, 3/8-16 x 1 1/4" Hex Head Grade 5	F05007-123	3
11	Decal, Board Return Table Warning	016077	1
12	Decal, Board Return Danger	015365	1

10.6 Pivot Bed Rail Assembly

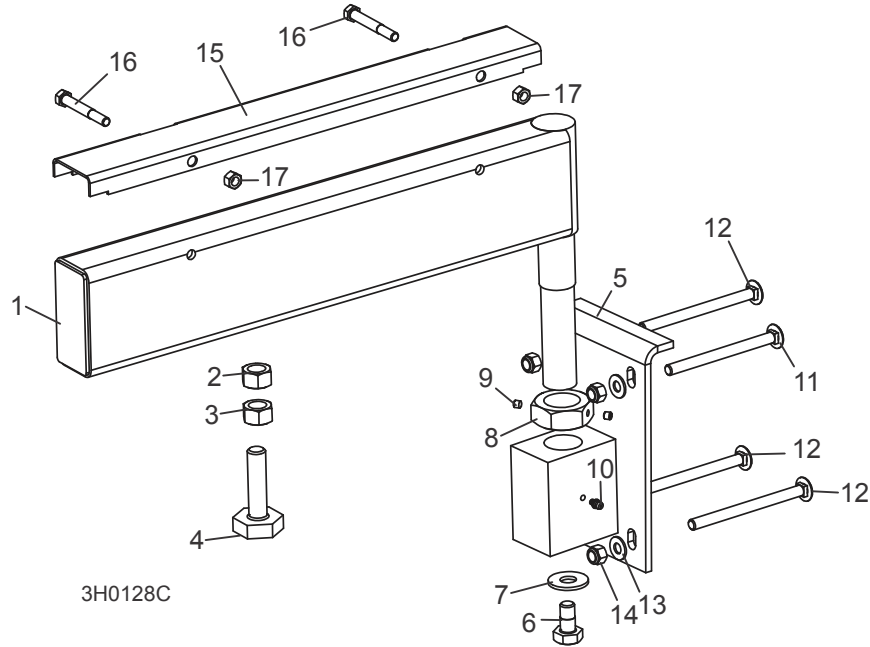

REF	DESCRIPTION (◆ Indicates Parts Available In Assemblies Only)	PART #	QTY.	
	PIVOT BED RAIL ASSEMBLY (LT40)	A13015	2	
	PIVOT BED RAIL ASSEMBLY (LT30)	012993	2	
1	Pivot Bed Rail Weldment (LT40)	W13014	1	◆
	Pivot Bed Rail Weldment (LT30)	012992	1	◆
2	Nut, 5/8-11 Pilot Weld	F05010-84	2	
3	Nut, 5/8-11 Hex	F05010-5	2	
4	Bolt, Bed Rail Adjustment	S13006	2	
5	Bracket, Pivot Rail Mounting	W13090	1	
6	Bolt, 1/2-13 x 1" Hex Head Grade 2	F05008-50	1	
7	Washer, 9/16" SAE Flat	F05011-52	1	
8	Nut, Pivot Rail Adjustment	S13016	1	
9	Screw, 1/4-28 x 1/4" Brass Tip Set	F05005-42	2	
10	Fitting, 3/16" Grease	P04107	1	
11	BOLT, 3/8-16 X 4 3/4" CARRIAGE HEAD	F05007-114	2	
12	BOLT, 3/8-16 X 5" CARRIAGE HEAD	F05007-113	6	
13	WASHER, 3/8" SAE FLAT	F05011-3	8	
14	NUT, 3/8-16 NYLON LOCK	F05010-10	8	
	COVER KIT, PIVOT RAIL STAINLESS STEEL (LT40)	017710	2	
	COVER KIT, PIVOT RAIL STAINLESS STEEL (LT30)	015926	2	
15	Cover, Stainless Steel Pivot Bed Rail (LT40)	S13012	1	
	Cover, Stainless Steel Pivot Bed Rail (LT30)	012994	1	
16	Bolt, 5/16-18 X 2 1/2" Hex Head	F05006-10	2	

10

Bed Frame Assembly

Pivot Bed Rail Assembly

17	Nut, 5/16-18 Hex Lock	F05010-6	2	
	WRENCH, BED RAIL ADJUSTMENT (See Section 10.1)	015970	1	

10.7 Log Side Support Assembly (Manual)

[See Section 11.7](#) for optional hydraulic side supports

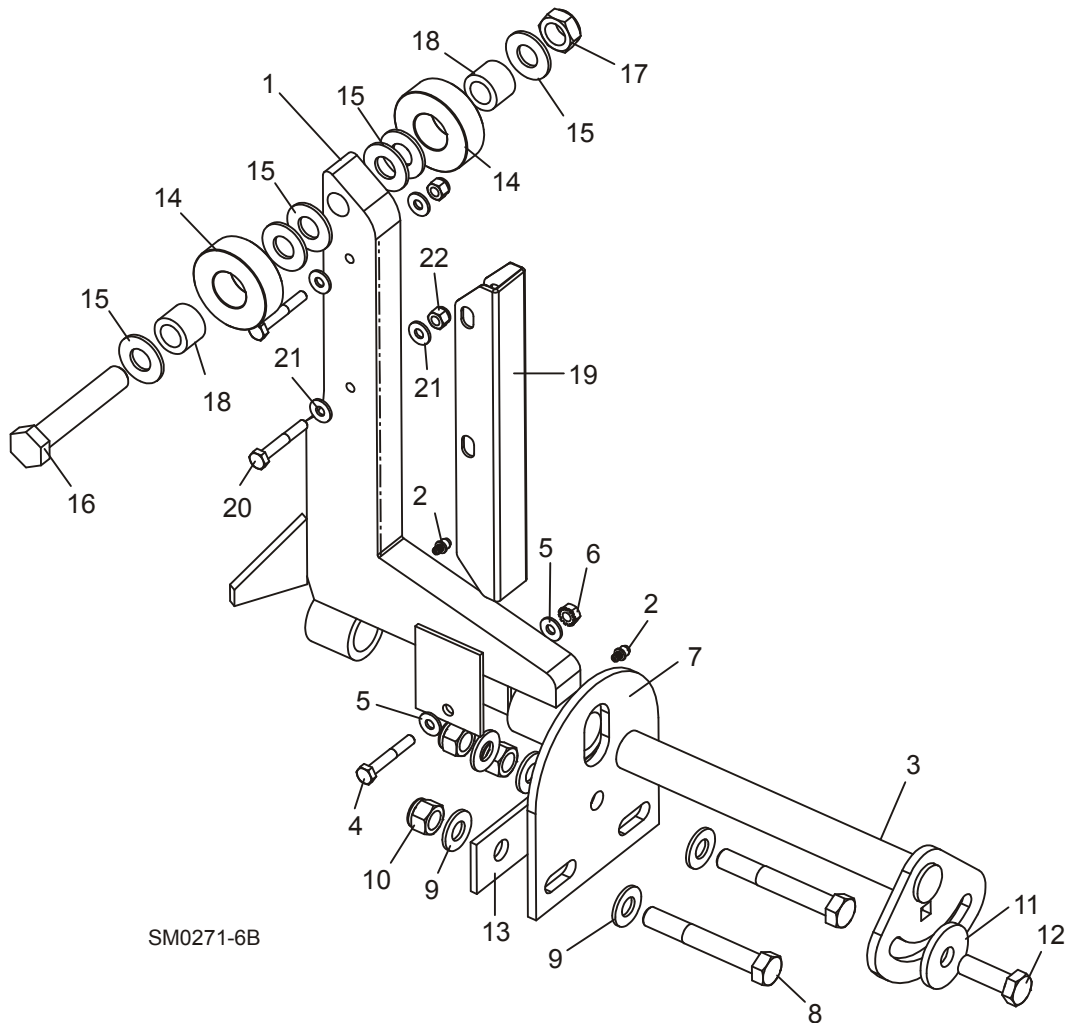

REF	DESCRIPTION (◆ Indicates Parts Available In Assemblies Only)	PART #	QTY.
1	SUPPORT, LOG SIDE	015235	4
2	Fitting, 3/16" Grease	P04107	2
	MOUNTING KIT, LOG SIDE SUPPORT	016559	4
3	Pin, Log Side Support Pivot	016544	1
4	Bolt, 1/4-20 X 1 1/2" Hex Head Grade 5	F05005-4	1
5	Washer, 1/4" SAE Flat	F05011-11	2
6	Nut, 1/4-20 Self Locking	F05010-9	1
7	Plate, Log Side Support End	016555	1
8	Bolt, 1/2-13 X 3 1/2" Hex Head Grade 5	F05008-61	2
9	Washer, 1/2" SAE Flat	F05011-2	5
10	Nut, 1/2-13 Hex Nylon Lock	F05010-8	3

10

Bed Frame Assembly Log Side Support Assembly (Manual)

11	Washer, .52" x 1.69"	014632	1	
12	Bolt, 1/2-13 X 1 1/2" Hex Head Grade 5	F05008-33	1	
13	Plate, Side Support Washer Clamp	016558	1	
	ROLLER KIT, SIDE SUPPORT	016562	4	
14	Roller, Side Support	016561	2	
15	Washer, 5/8" SAE Flat	F05011-5 ¹	6	
16	Bolt, 5/8-11 x 3 3/4" Hex Head Grade 5	F05009-118	1	
17	Nut, 5/8-11 Hex Nylon Lock Jam	F05010-96	1	
18	Bushing, Bronze 5/8" x 1" x 3/4"	016560	2	
	Bolt, 1/2-13 x 3 1/2" Carriage Head	F05008-94	1	
	Instruction Sheet, Side Support Roller	016562-526	1	
	GUARD KIT, STAINLESS STEEL SIDE SUPPORT	016798	1	
19	Guard, Stainless Steel Side Support	016722	4	
20	Bolt, 1/4-20 x 1 3/4" Hex Head	F05005-4	8	
21	Washer, 1/4" SAE Flat	F05011-11	16	
	Washer, 5/8" SAE Flat	F05011-5 ¹	4	
22	Nut, 1/4-20 Hex Nylon Lock	F05010-69	8	
	Instruction Sheet, Stainless Steel Side Support Guard Retro	016798-1005	1	

¹ Additional 5/8" SAE Flat Washer F05011-5 may be required on each side of side support to provide clearance for optional stainless steel side support guards. Extra washers are included in the stainless steel guard retrofit kit (016798).

10.8 Safety Chain Assembly

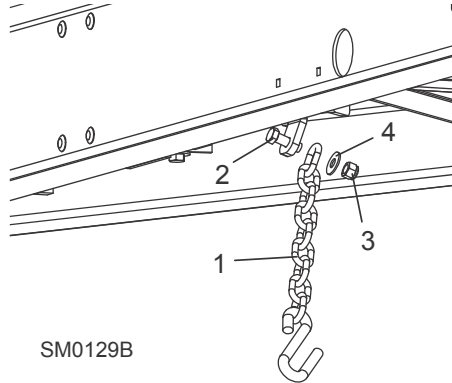

REF	DESCRIPTION (◆ Indicates Parts Available In Assemblies Only)	PART #	QTY.	
1	CHAIN, 15 INCH SAFETY	107972	1	
2	BOLT, 1/2-13X1 1/2 HEX HEAD GRADE 5	F05008-33	1	
3	NUT, 1/2-13 NYLON HEX LOCK	F05010-8	1	
4	WASHER, 7/16 STANDARD FLAT	F05011-35	1	

10 Bed Frame Assembly

Bed Frame Decals

10.9 Bed Frame Decals

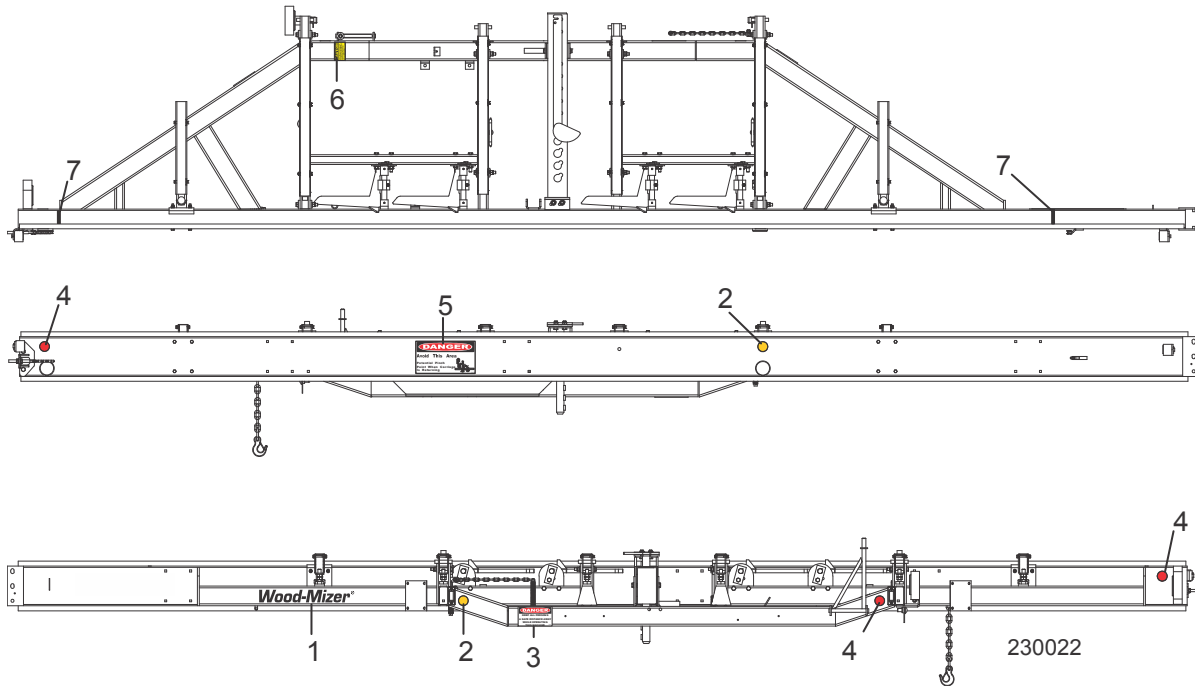

REF	DESCRIPTION (◆ Indicates Parts Available In Assemblies Only)	PART #	QTY.
1	DECAL, WOOD-MIZER SUPER LOGO	014751	1
2	DECAL, AMBER REFLECTIVE 2" ROUND	P07453	2
3	DECAL, KEEP AWAY DANGER	S09851	1
4	DECAL, RED REFLECTIVE 2" ROUND	P07452	3
5	DECAL, PINCH POINT DANGER	P10287	1
6	DECAL, SAW HEAD REST CAUTION	S12581	1
7	DECAL, LOG LIMIT STRIPE	S12051	2

10.10 Log Clamp

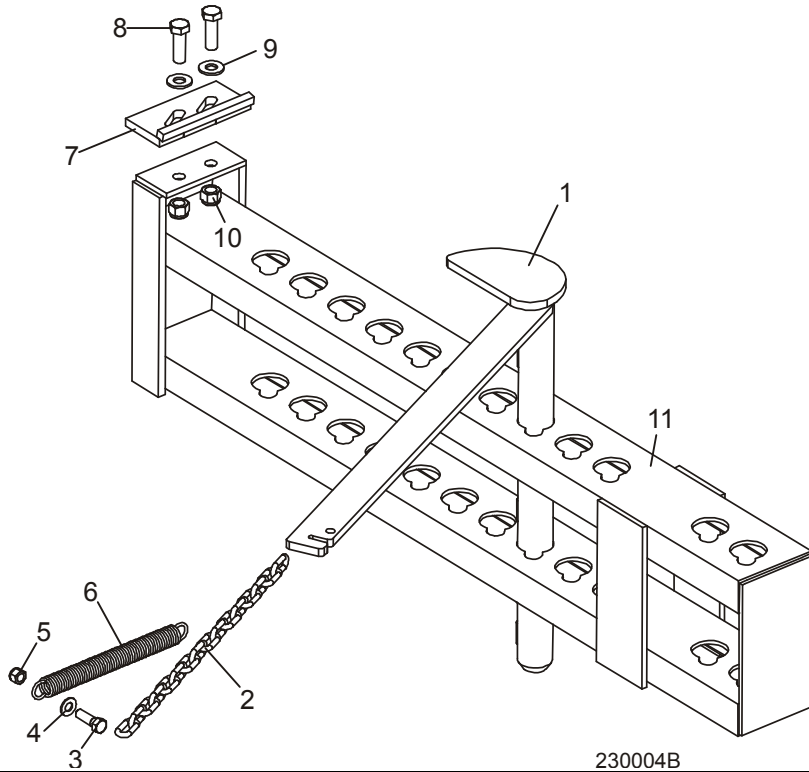

230004B

REF	DESCRIPTION (◆ Indicates Parts Available In Assemblies Only)	PART #	QTY.
1	CLAMP, LOG	W09412	1
2	CHAIN, LOG CLAMP	M04311	1
3	BOLT, 3/8-16 X 1 1/4" HEX HEAD GRADE 2	F05007-2	1
4	WASHER, 3/8" STANDARD FLAT	F05011-3	2
5	NUT, 3/8-16 HEX NYLON LOCK	F05010-10	1
6	SPRING, LOG CLAMP CHAIN	P09136	1
7	PLATE, LOG CLAMP STOP	W09404	1
8	BOLT, 1/2-13 X 1 1/2" HEX HEAD GRADE 5	F05008-33	2
9	WASHER, 1/2" SAE FLAT	F05011-2	2
10	NUT, 1/2-13 HEX NYLON LOCK	F05010-8	2
11	CHANNEL WELDMENT, MANUAL LOG CLAMP	W09310	1

1 **Bed Frame Assembly**
Log Loading Ramps

10.11 Log Loading Ramps

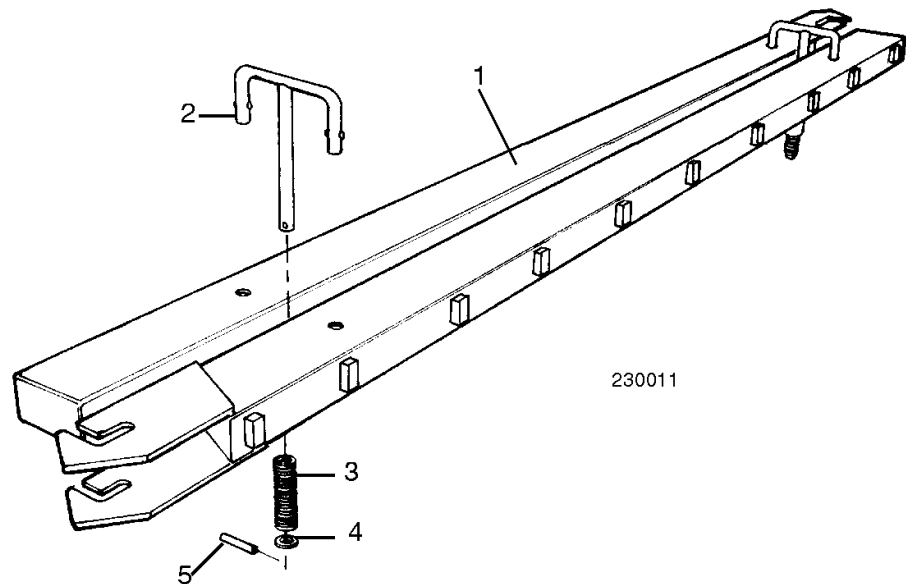

REF	DESCRIPTION (◆ INDICATES PARTS AVAILABLE IN ASSEMBLIES ONLY)	PART #	QTY.	
	RAMP KIT, LOG LOADING WITH RETAINERS	K09466	1	
1	Ramp, Log Loading	W09014	2	
	Retainer Kit, Log Ramp	K09810	2	
2	Retainer, Log Ramp	W09413	1	◆
3	Spring, Log Ram Retainer	P09335	1	
4	Washer, 5/8" I.D. x .100" Thick Nylon	F05011-19	1	
5	Pin, 3/16" x 1" Roll	F05012-11	1	

10.12 Board Outfeed Table (Optional)

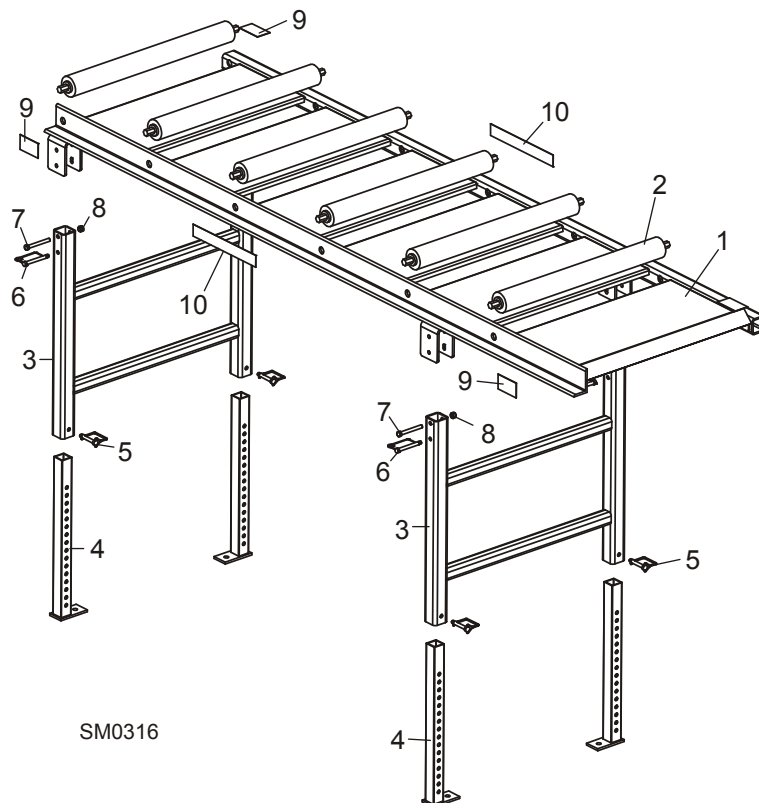

REF	DESCRIPTION (◆ Indicates Parts Available In Assemblies Only)	PART #	QTY.
	TABLE ASSEMBLY, BOARD OUTFEED	016652	1
1	Table Weldment, Board Outfeed	016606	1
2	Roller, 2 1/2" x 25"	038167	6
3	Mount Weldment, Outfeed Table Leg	016609	2
4	Leg Weldment, Outfeed Table	016651	4
5	Pin, 3/8" x 2 1/4" Square Wire Lock	014151	4
6	Pin, Snap - Coil Tension	016677	4
7	Bolt, 3/8-16 x 3 1/4" Hex Head	F05007-135	4
8	Nut, 3/8-16 Hex Nylon Lock	F05010-10	4
9	Decal, Hand Pinch Point Warning	S12641	4
10	Decal, 1 1/2" Wood-Mizer Logo	016991	2

SECTION 11 BED HYDRAULIC LOG LOADER & TURNER (OPTIONAL)

11.1 Hydraulic Hoses

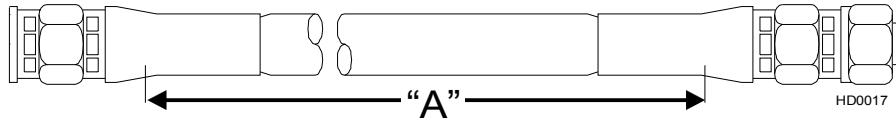

COLOR	LENGTH "A"	DESCRIPTION (NOTE: See Hydraulic Information Section in Operator's Manual for Hydraulic Schematics)	PART #	QTY.
Green	62"	LOADING ARM BRANCH TOP	079000-62	2
Yellow	64"	LOADING ARM BRANCH BASE	079000-64	2
Blue	148" ¹	LOADING ARM TOP	079000-148	1
Red	158" ¹	LOADING ARM BOTTOM	079000-158	1
Plain	27"	LOG TURNER BASE	079000-27	1
Orange	18"	LOG TURNER TOP	079000-18	1
Plain	220"	SIDE SUPPORT TOP	079000-220	1
Pink	206"	SIDE SUPPORT BASE	079000-206	1

¹ Length changed from 164" HLA Rev. A3.00

11.2 Hydraulic Loader/Turner Control Box

HCA/HCA-A

Rev. A1.00+

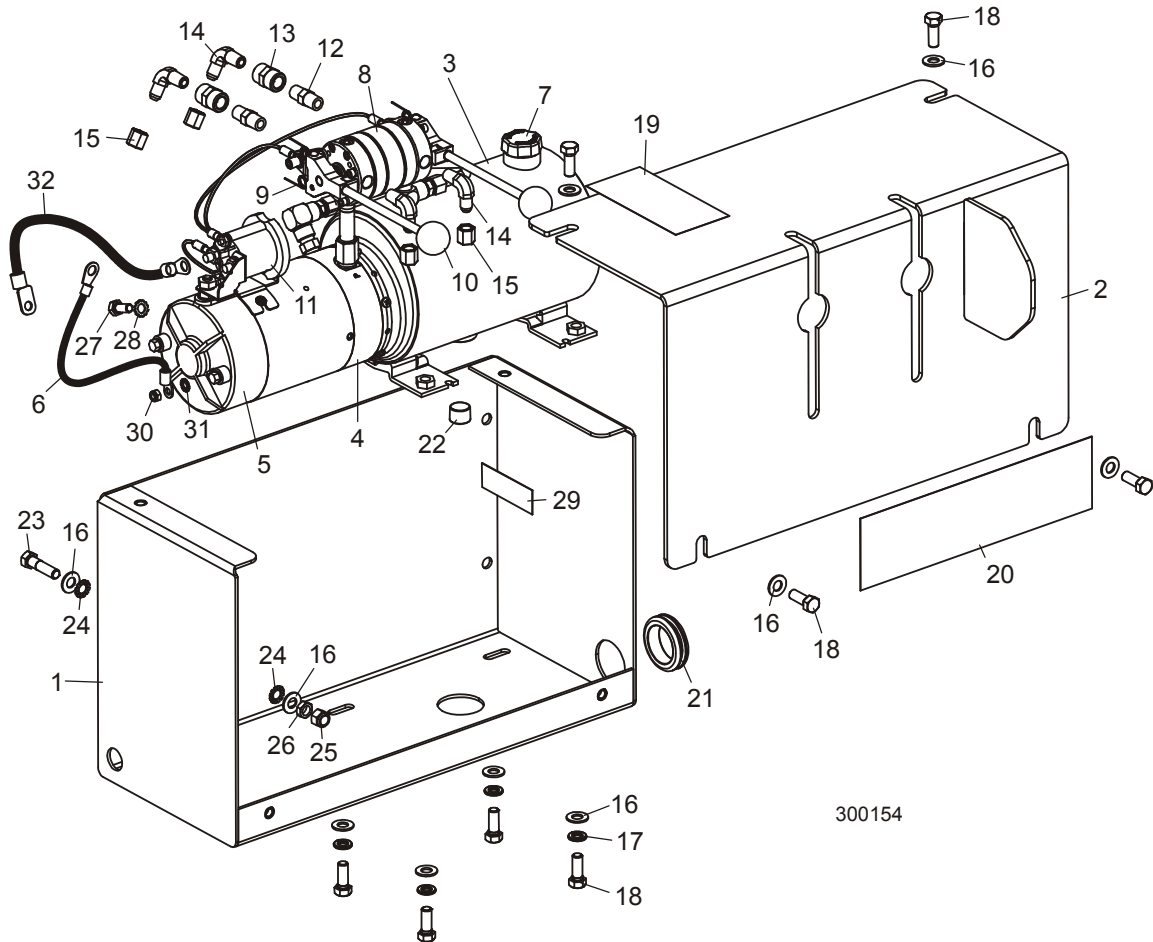

REF	DESCRIPTION (◆ Indicates Parts Available In Assemblies Only)	PART #	QTY.
	BOX ASSEMBLY, HYDRAULIC DUAL FUNCTION CONTROL	025717	1
1	Box Weldment, Hydraulic Dual Function Control	025716	1
2	Cover Weldment, Hydraulic Dual Function Control	025714	1
3	Pump/Valve Assembly, Hydraulic Dual Function #M-500 4W/4W	025713	1
4	Pump, Hydraulic Replacement Monarch Model #12171-250		1
	Motor Kit, Hydraulic Replacement	052807	1
5	Motor, 12 VDC Hydraulic Pump #08714 (Iskra)	038683	1 ◆
	Brush Kit, 4-Valve Hydraulic Pump Motor #08658-I (Iskra)	038682	1
	Bearing, Base Motor #02318	P12513	1
6	Wire Assembly, Motor Brush Ground	052806	1
7	Cap, Hydraulic Pump Vented Fill #01143	P09596	1
8	Valve Assembly, 4-Way Monarch #19760		2

11

Bed Hydraulic System Hydraulic Loader/Turner Control Box

9	Spring, Hydraulic Pump Valve Contact #00015	025818	4	
10	Handle Assembly, Hydraulic Pump Valve #		2	
	Spring, Hydraulic Pump Valve Handle #00018	P09753	2	
11	Solenoid, 12 VDC Motor Starter #17744		1	
12	Fitting, 1/4" NPT Hex Nipple	P05389	2	
13	Fitting, 1/4" NPT Coupling	P03420	2	
14	Fitting, 1/4" NPT x 1/4" JIC Male Elbow	P09142	4	
15	Fitting, 1/4" JIC Cap	016815	4	
16	Washer, 3/8" SAE Flat	F05011-3	10	
17	Washer, 3/8" Split Lock	F05011-4	4	
18	Bolt, 3/8-16 X 1" Hex Head Grade 5	F05007-87	8	
19	Decal, Keep Away Hydraulic Warning	P12961	1	
20	Decal, Hydraulic Logo	036720	1	
21	Grommet, 1 1/2" x 3/16"	043405	1	
22	Fitting, 1/2" NPT Plug	P26258	1	
23	Bolt, 3/8-16 x 1 1/2" Hex Head Grade 5	F05007-78	1	
24	Washer, 3/8" External Star Lock	F05011-36	2	
25	Nut, 3/8-16 Hex Nylon Lock	F05010-10	1	
26	Nut, 3/8-16 Hex Jam	F05010-29	1	
27	Bolt, 5/16-18 x 3/4" Hex Head	F05006-5	1	
28	Washer, 5/16" External Star Lock	F05011-33	1	
29	Decal, Hydraulic Fluid	S12825	1	
30	Nut, M6-1.0 Hex Nylon Lock	F05010-200	1	
31	Washer, 1/4" Exterior Star Lock	F05011-37	1	
32	Cable Assembly, 10" Pump To Solenoid		1	
	FLUID, 1-QUART DEXRON III HYDRAULIC	P12742	4	
	FLUID, 1-GALLON CONOCO MV32	006397	1	
	FLUID, 1-GALLON EXXON UNIVIS HVI 13 HYDRAULIC	P12822	1	

11.3 Hydraulic Loader Control Box

HLA/HLA-A

Rev. A1.00 - A2.03

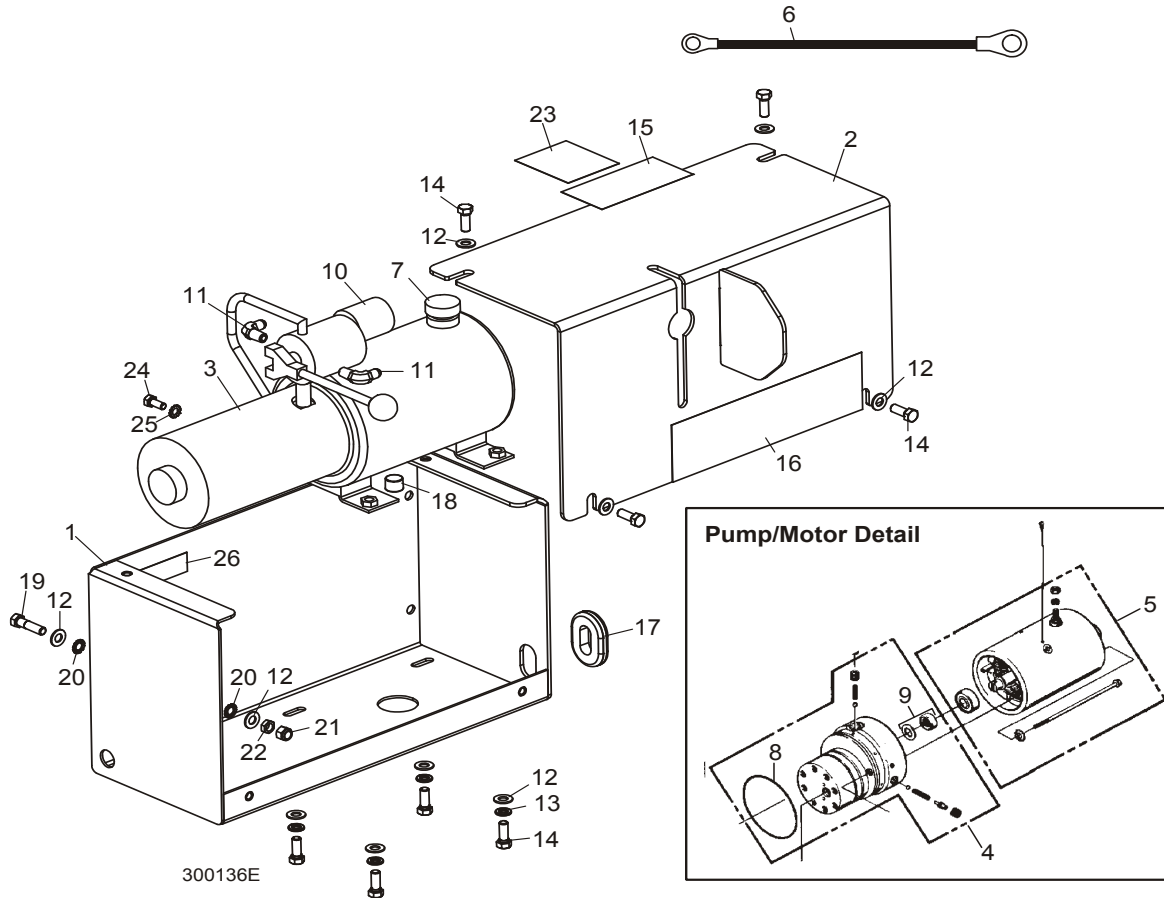

REF	DESCRIPTION (◆ Indicates Parts Available In Assemblies Only)	PART #	QTY.
	BOX ASSEMBLY, HYDRAULIC LOG LOADER CONTROL	048380	1
1	Box Weldment, Hydraulic Loader Control	048381	1
2	Cover Weldment, Hydraulic Loader Control	048387	1
3	Pump Assembly, Hydraulic Loader w/Motor #M-310	048386	1
4	Pump, Hydraulic Replacement Monarch Model #12070	016199	1
	Motor Kit, Hydraulic Replacement	052807	1
5	Motor, 12 VDC Hydraulic Pump #08714 (Iskra)	038683	1 ◆
	Brush Kit, 4-Valve Hydraulic Pump Motor #08658-I (Iskra)	038682	1
	Bearing, Base Motor #02318	P12513	1
6	Wire Assembly, Motor Brush Ground	052806	1
7	Cap, Hydraulic Pump Vented Fill #03171	P12817	1
8	O-Ring, Hydraulic Pump/Reservoir #02352	P10198	1
9	Seal, Hydraulic Pump/Motor #02330	P10315	1
10	Valve Assembly, 4-Way Monarch #00524	P10143	1

11

Hydraulic Log Loader (Optional)

Hydraulic Loader Control Box

11	Electrical Parts Kit, Hydraulic Pump Valve #03721	P09593	1	
12	Spring, Hydraulic Pump Valve Contact #99188	P09846	1	
13	O-ring, Hydraulic Pump Valve Cover #02354	P09592	1	
14	Handle Assembly, Hydraulic Pump Valve #00172	P09594	1	
15	Spring, Hydraulic Pump Valve Handle #00018	P09753	1	
16	Solenoid, 12 VDC 3 Post Insulated Ground #3301	P09595	1	
17	Fitting, 1/4" NPT x 1/4" JIC Male Elbow	P09142	2	
18	Washer, 3/8" SAE Flat	F05011-3	10	
19	Washer, 3/8" Split Lock	F05011-4	4	
20	Bolt, 3/8-16 X 1" Hex Head Grade 5	F05007-87	8	
21	Decal, Keep Away Hydraulic Warning	P12961	1	
22	Decal, Hydraulic Logo	036720	1	
23	Grommet, 1" x 1 3/4" Oval Rubber	085613	1	
24	Fitting, 1/2" NPT Plug	P26258	1	
25	Bolt, 3/8-16 x 1 1/2" Hex Head Grade 5	F05007-78	1	
26	Washer, 3/8" External Star Lock	F05011-36	2	
27	Nut, 3/8-16 Hex Nylon Lock	F05010-10	1	
28	Nut, 3/8-16 Hex Jam	F05010-29	1	
29	Decal, Hydraulic Loader Option Warning	052213	1	
30	Bolt, 5/16-18 x 3/4" Hex Head	F05006-5	1	
31	Washer, 5/16" External Star Lock	F05011-33	1	
32	Decal, Hydraulic Fluid	S12825	1	
	FLUID, 1-QUART DEXRON III HYDRAULIC	P12742	2 1/4 gal.	
	FLUID, 1-GALLON CONOCO MV32	006397	2 1/4 gal.	
	FLUID, 1-GALLON EXXON UNIVIS HVI 13 HYDRAULIC	P12822	2 1/4 gal.	

11.4 Hydraulic Power Supply Strip

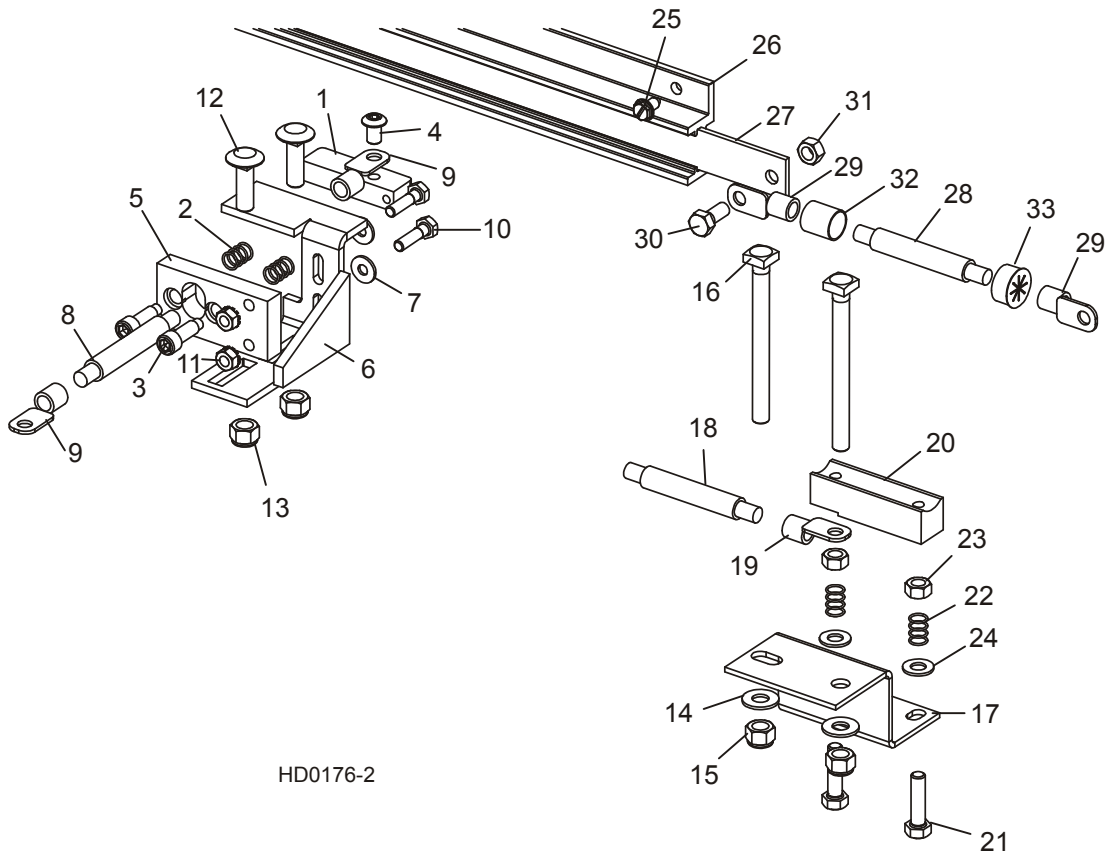

HD0176-2

REF	DESCRIPTION (◆ Indicates Parts Available In Assemblies Only)	PART #	QTY.	
	Contact Kit, 97+ Hydraulic Power Supply Positive	007716	1	
1	Contact, Hydraulic Power Supply (Positive)	015253	1	◆
2	Spring, Positive Contact	P10077	2	
3	Bolt, 5/16" X 3/4" Shoulder (1/4-20 Thread) Stainless	F05006-143	2	
4	Bolt, 5/16-18 x 1/2" Socket Button Head	F05006-20	1	
5	Insulator, Positive Contact	S10072	1	
6	Bracket, Positive Contact Mounting	015324	1	
7	Washer, 1/4" SAE Flat	F05011-11	2	
	Cable Assy, Hydraulic Positive Contact	N/A	1	
8	Cable, #1 Weld	R01971	Ft	◆
9	Terminal, 5/16" Ring #2 Gauge	F05092-16	2	
10	Bolt, 1/4-20 X 1" Hex Head Grade 2	F05005-38	2	
11	Nut, 1/4-20 Hex Self-Locking	F05010-9	2	
12	Bolt, 3/8-16 X 1 1/4" Carriage Head	F05007-11	2	

Bed Hydraulic System

Hydraulic Power Supply Strip

13	Nut, 3/8-16 Hex Nylon Lock	F05010-10	2	
	CONTACT KIT, HYDRAULIC POWER SUPPLY (GROUND)	010104	1	
14	Washer, 3/8" SAE Flat	F05011-3	2	
15	Nut, 3/8-16 Hex Nylon Lock	F05010-10	2	
16	Bolt, 3/8-16 X 4" Square Head	F05007-175	2	
17	Bracket, Ground Contact Mounting	016792	1	
18	Cable Assy, Hydraulic Negative Contact (Ground) #1 Weld	036306	1	
	Cable, #1 Weld	R01971	2.2 Ft	◆
19	Terminal, 5/16" Ring #2 Gauge	F05092-16	2	
	Contact Kit, Hydraulic Power Supply Ground	007717	1	
20	Contact, Hydraulic Power Supply (Ground)	015264	1	◆
21	Bolt, 5/16-18 X 1 1/4" Hex Head Full Thread Grade 5	F05006-93	2	
22	Spring, Ground Contact	P10077	2	
23	Nut, 5/16-18 Hex	F05010-17	2	
24	Washer, 5/16" SAE Flat	F05011-17	2	
	STRIP ASSEMBLY, 6' HYDRAULIC POWER SUPPLY W/3 FT. CABLE	A11977	1	
25	Screw, 1/4-20 X 1/2" Slotted Hex Head	F05015-1	8	
26	Housing, 6' Contact Strip	P11976	1	
	Strip, 6' Contact With Cable	A12043-N	1	
27	Strip, 6' Contact	S10075	1	◆
28	Cable Assembly, Hydraulic Contact Strip	052161		
	Cable, #1 Weld	R01971	Ft	◆
29	Terminal, 5/16" Ring #2 Gauge	F05092-16	2	
30	Bolt, 5/16-18 X 3/4" Hex Head Black Nylon	F05006-45	1	
31	Nut, 5/16-18 Hex Black Nylon	F05010-86	1	
32	Tube, 5/8" Heat Shrink	R01950-8	Ft	◆
33	Grommet, 5/8" Wire	P04137	1	

11.5 Hydraulic Log Loader (Optional)

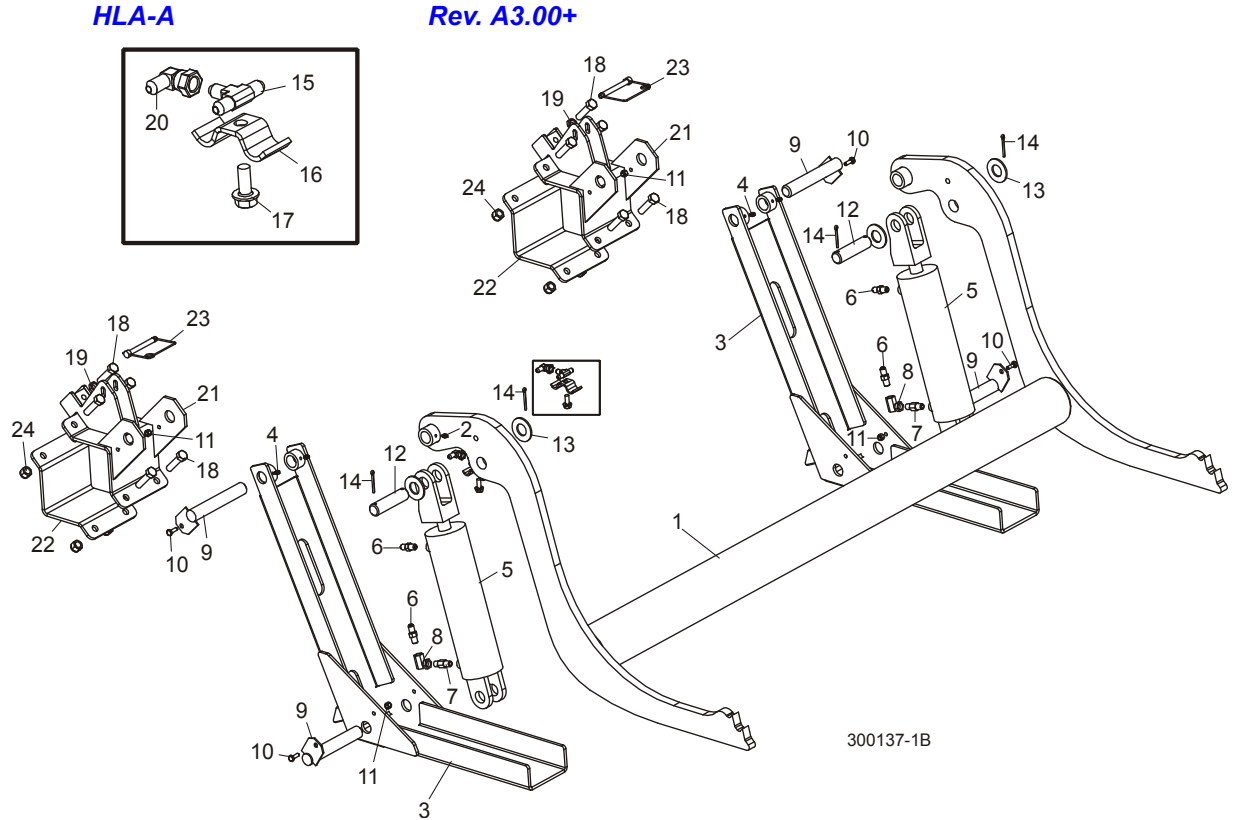

REF	DESCRIPTION (◆ Indicates Parts Available In Assemblies Only)	PART #	QTY.
	LOADER KIT, HYDRAULIC LOG (MANUAL SAWMILL OPTION)	LTHDLA-M	1
1	Arm, Hydraulic Log Loading	036722	1
2	Fitting, 3/16" Grease	P04107	2
3	Channel, Hydraulic Log Loading Foot	W09444	2
4	Fitting, 3/16" Grease	P04107	4
	Cylinder Assembly, Hydraulic Log Loading Arm	A09284	2 ◆
5	Cylinder, 8" X 3" Hydraulic	P12847	1
	Seal Kit, 8" x 3" Hydraulic Cylinder	P12956	1
6	Fitting, C5205x4x4 Male Connector	P09143	2
7	Fitting, 0455x4x4 90° Swivel Elbow	P12199	1
	Fitting Kit, 1/4NPT 5.0GPM Velocity Fuse	015832	1
8	Fitting, 1/4NPT 5.0GPM Velocity Fuse	015750	2 ◆
	Instruction Sheet, Velocity Fuse Replacement	015832-255	1
9	Pin, Loading Arm Mount	W09446	4
10	Bolt, 1/4-20 x 3/4" Hex Head Full Thread	F05005-1	4
11	Nut, 1/4-20 Hex Lock	F05010-69	4
12	Pin, Loading Arm Cylinder Mount	S09251	2

11*Hydraulic Log Loader (Optional)*

13	Washer, 1" SAE Flat	F05011-28	4	
14	Pin, 3/16" X 1 1/2" Cotter	F05012-23	4	
15	Fitting, C5705x5x4 Union 'T'	P09145	2	
16	Clamp, 1/4" Hydraulic Hose	S09245		
17	Bolt, 5/16-18 X 3/4" Hex Head Grade 5	F05006-102		
18	BOLT, 1/2-13 X 2" HEX HEAD FULL THREAD GRADE 5	F05008-116		
19	NUT, 1/2-13 JAM	F05010-31	2	
20	FITTING, 1/4" JIC X 1/4" JIC ELBOW	036715	2	
21	MOUNT WELDMENT, LOADER ARM	048270	2	
22	PLATE WELDMENT, LOADER ARM MOUNT	036737	2	
23	PIN ASSEMBLY, 3/8" X 3" WIRE LOCK	038472	2	
24	NUT, 1/2-13 HEX NYLON LOCK	F05010-8	8	

11.6 Hydraulic Log Turner (Optional)

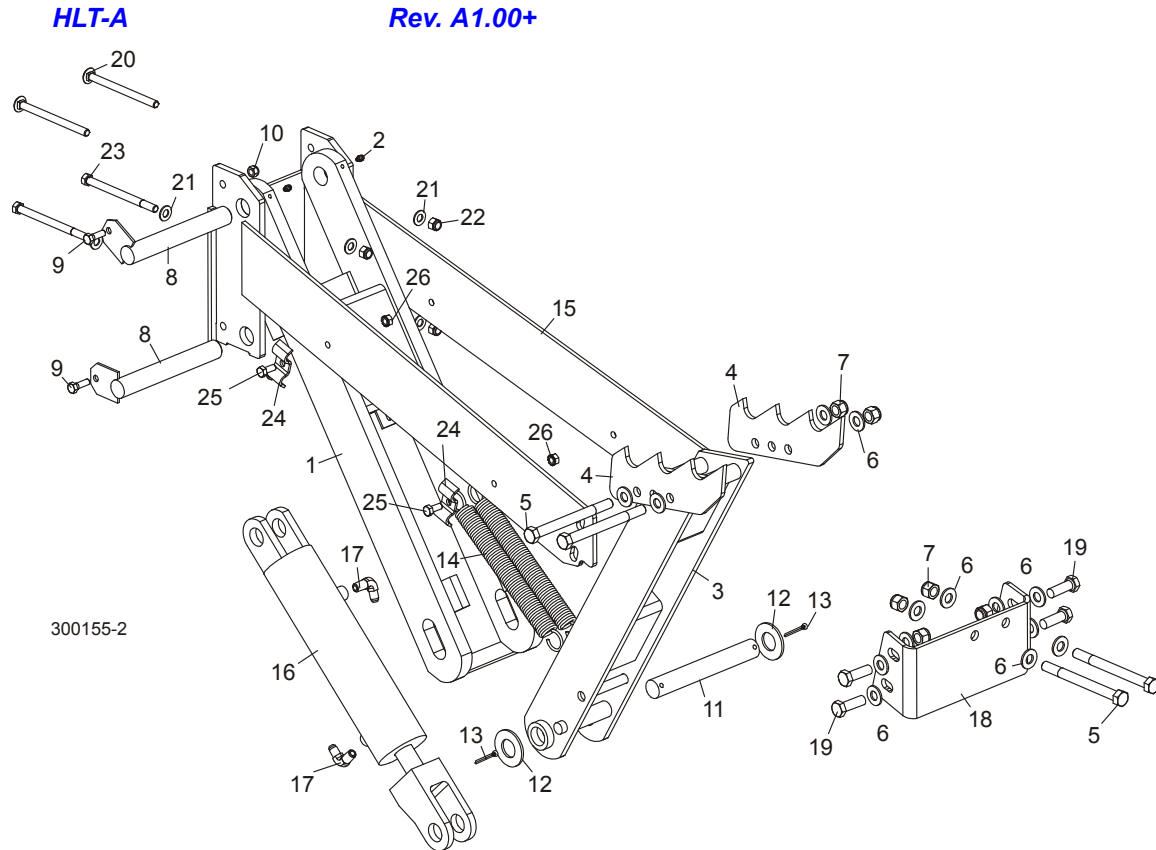

REF	DESCRIPTION (◆ Indicates Parts Available In Assemblies Only)	PART #	QTY.
	ARM ASSEMBLY, MANUAL MILL HYDRAULIC TURNER	007069	1
1	Arm, Hydraulic Log Turner Link	015231	1
2	Fitting, 3/16" Grease	P04107	2
3	Arm, Hydraulic Log Turner Painted	015233	1
4	Claw, Hydraulic Log Turner	014675	2
5	Bolt, 1/2-13 X 5 1/2" Hex Head Grade 5	F05008-28	4
6	Washer, 1/2" SAE Flat	F05011-2	16
7	Nut, 1/2-13 Hex Nylon Lock	F05010-8	8
8	Pin, Log Turner Mount	015085	2
9	Bolt, 5/16-18 X 1" Hex Head Grade 2	F05006-1	2
10	Nut, 5/16-18 Hex Nylon Lock	F05010-58	2
11	Pin, Log Turner Pivot	S09246	1
12	Washer, 1" SAE Flat	F05011-28	2
13	Pin, 3/16" X 1 1/2" Cotter	F05012-23	2
14	Spring, Hydraulic Log Turner	015718	2
15	Mount Weldment, Manual Mill Hydraulic Log Turner	006999	1

11

Bed Hydraulic System Hydraulic Log Turner (Optional)

	Cylinder Assembly, Hydraulic Log Turner	A09286	1	
16	Cylinder, 8" X 2 1/2" Hydraulic	P12846	1	◆
	Seal Kit, 8" x 2 1/2" Hydraulic Cylinder	P12955	1	
17	Fitting, 1/4" NPT x 1/4" JIC 90° Male Elbow	P09142	2	
18	Plate, Manual Mill Hydraulic Log Turner Mount	007048	1	
19	Bolt, 1/2-13 x 1 1/2" Hex Head Grade 5	F05008-33	4	
20	Bolt, 3/8-16 x 5" Carriage Head	F05007-113	2	
21	Washer, 3/8" SAE Flat	F05011-3	6	
22	Nut, 3/8-16 Hex Nylon Lock	F05010-10	4	
23	Bolt, 3/8-16 x 5" Hex Head	F05007-5	2	
24	Plate, 1/4" Hose Clamp	S09245	2	
25	Bolt, 5/16-18 x 3/4" Hex Head Grade 5	F05006-102	2	
26	Nut, 5/16-18 Hex Self-Locking	F05010-20	2	

11.7 Hydraulic Log Side Supports (Optional)

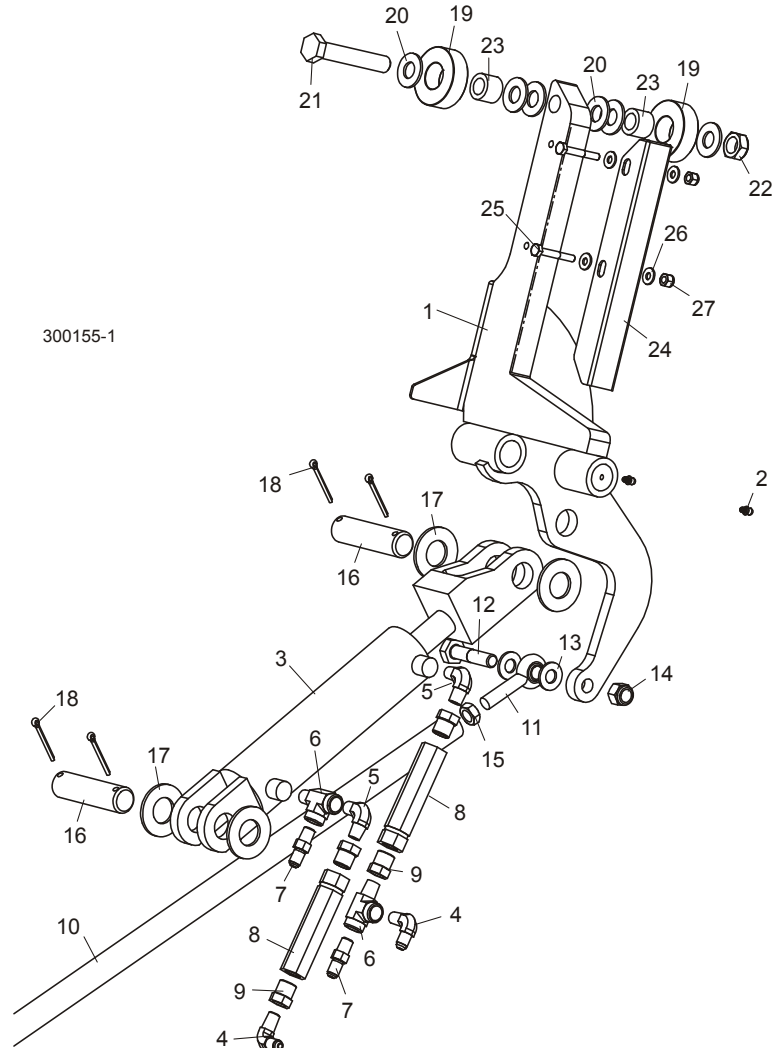

REF	DESCRIPTION (◆ Indicates Parts Available In Assemblies Only)	PART #	QTY.
1	SUPPORT, HYDRAULIC LOG SIDE	W12339	2
2	Fitting, 3/16" Straight Grease	P04107	2
	CYLINDER ASSEMBLY, HYDRAULIC LOG SIDE SUPPORT	A09283	1
3	Cylinder, 6" X 2" Hydraulic	P12845	1
	Seal Kit, 6" x 2" Hydraulic Cylinder	P12954	1
4	Fitting, 1/4" NPT x 1/4" JIC 90° Male Elbow	P09142	2
5	Fitting, 1/4" NPT 90° Male Elbow	P09140	2
6	Fitting, 1/4" NPT x 1/4" JIC Male Run 'T'	P09141	2
7	Fitting, 1/4" NPT x 1/4" JIC Male Connector	P09143	2
8	Valve, Hydraulic Sequence	015484	2
9	Fitting, 3/8" NPT - 1/4" NPT Reducer	015490	4

11

Bed Hydraulic System Hydraulic Log Side Supports (Optional)

10	ROD, HYDRAULIC SIDE SUPPORT LINK	015026	1	
11	END, 1/2" ROD	P09137	2	
12	BOLT, 1/2-13 X 2 1/4" HEX HEAD GRADE 5	F05008-10	2	
13	WASHER, 1/2" SAE FLAT	F05011-2	4	
14	NUT, 1/2-13 HEX NYLON LOCK	F05010-8	2	
15	NUT, 1/2-20 HEX JAM	F05010-16	1	
16	PIN, CYLINDER MOUNT	S09251	2	
17	WASHER, 1" SAE FLAT	F05011-28	4	
18	PIN, 3/16" X 1 1/2" COTTER	F05012-23	4	
	ROLLER KIT, SIDE SUPPORT (OPTIONAL)	016562	2	
19	Roller, Side Support	016561	2	
20	Washer, 5/8" SAE Flat	F05011-5 ¹	6	
21	Bolt, 5/8-11 x 3 3/4" Hex Head Grade 5	F05009-118	1	
22	Nut, 5/8-11 Hex Nylon Lock Jam	F05010-96	1	
23	Bushing, Bronze 5/8" x 1" x 3/4"	016560	2	
	Bolt, 1/2-13 x 3 1/2" Carriage Head	F05008-94	1	
	Instruction Sheet, Side Support Roller	016562-526	1	
	GUARD KIT, STAINLESS STEEL SIDE SUPPORT (OPTIONAL)	016798	1	
24	Guard, Stainless Steel Side Support	016722	4	
25	Bolt, 1/4-20 x 1 3/4" Hex Head	F05005-4	8	
26	Washer, 1/4" SAE Flat	F05011-11	16	
	Washer, 5/8" SAE Flat	F05011-5 ¹	4	
27	Nut, 1/4-20 Hex Nylon Lock	F05010-69	8	
	Instruction Sheet, Stainless Steel Side Support Guard Retro	016798-1005	1	

¹ Additional 5/8" SAE Flat Washer F05011-5 may be required on each side of side support to provide clearance for optional stainless steel side support guards. Extra washers are included in the stainless steel guard retrofit kit (016798).

11.8 Miscellaneous Loader & Turner Parts

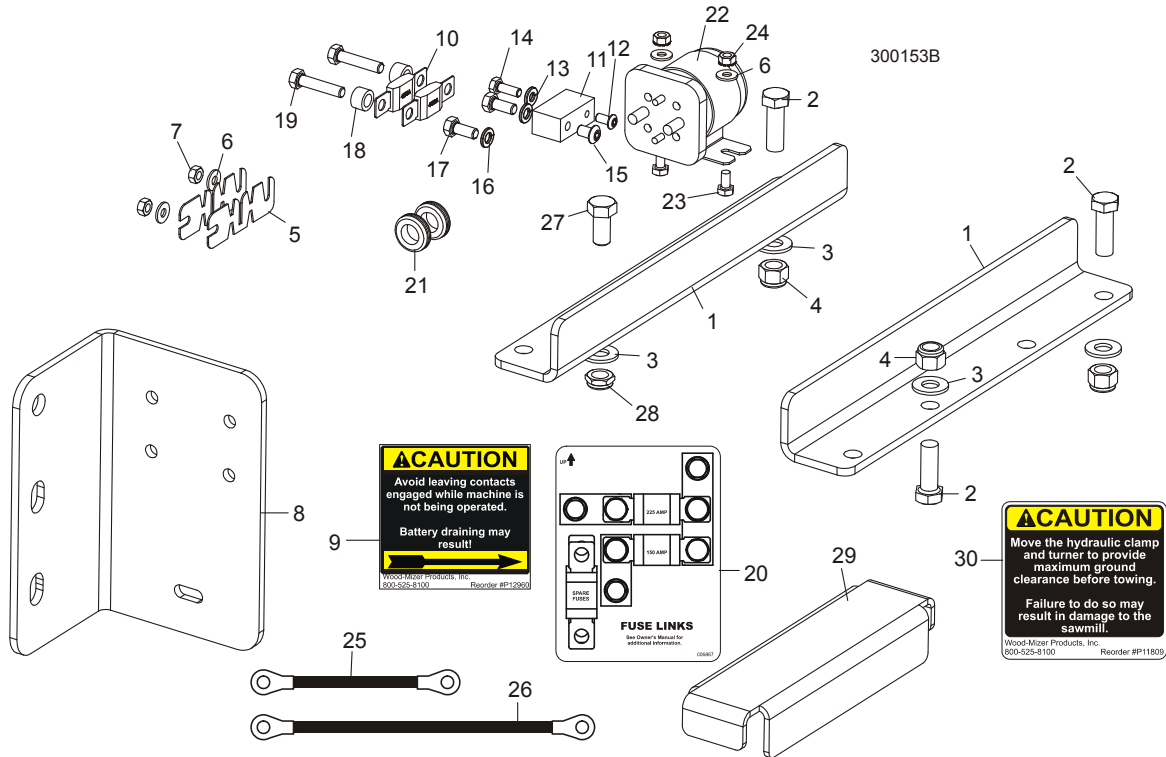

REF	DESCRIPTION (◆ Indicates Parts Available In Assemblies Only)	PART #	QTY.
1	PLATE, AXLE MOUNT	048269 ¹	2
2	BOLT, 1/2-13 X 1 1/2" HEX HEAD GRADE 5	F05008-33 ¹	3
3	WASHER, 1/2" SAE FLAT	F05011-2	4
4	NUT, 1/2" HEX NYLON LOCK	F05010-8 ¹	3
5	FUSE, 225A 12V	P11550	2
6	WASHER, 1/4" SAE FLAT	F05011-11	4
7	NUT, 1/4-20 HEX LOCK	F05010-21	2
8	BRACKET, WINCH MOUNT	048426	1
9	DECAL, HYDRAULIC CONTACT CAUTION	P12960	1
10	FUSE, 225A 32V MEGA	053339	2
11	BLOCK, 3/4" LOWER FUSE	056998	1
12	SCREW, 1/4-20 X 1/2" SOCKET BUTTON HEAD	F05005-59	1
13	WASHER, 1/4" SPLIT LOCK	F05011-14	1
14	BOLT, 1/4-20 X 3/4" HEX HEAD GRADE 5	F05005-123	1
15	SCREW, 5/16-18 X 1/2" SOCKET BUTTON HEAD	F05006-20	1
16	WASHER, 5/16" SPLIT LOCK	F05011-13	2
17	BOLT, 5/16-18 X 3/4" HEX HEAD GRADE 5	F05006-102	2
18	SPACER, .39" X .625" X .39"	055323	2

11

Hydraulic Log Loader & Turner (Optional)

Miscellaneous Loader & Turner Parts

19	BOLT, 5/16-18 X 1 1/2" HEX HEAD FULL THREAD	F05006-2	2	
20	DECAL, 150A/225A MEGA FUSE ID	006867	1	
21	GROMMET, 5/8" ID RUBBER	P11764	2	
22	SOLENOID KIT, 200A 12V SPST CONT. DUTY	016371 ²	1	
	Solenoid, 200A 12V SPST Cont. Duty	015470	1	◆
	Diode Assembly, Solenoid Coil Chassis Gnd	015426	1	
	WIRE ASSEMBLY, HYDRAULIC SOLENOID VOLTAGE DROP	024451 ²	1	
23	BOLT, 1/4-20 X 1/2" HEX HEAD	F05005-15 ²	2	
24	NUT, 1/4-20 SELF-LOCKING HEX	F05010-9 ²	2	
25	CABLE ASSEMBLY, 1 GA X 6 1/2" FUSE TO SOLENOID	036305 ²	1	
26	CABLE ASSEMBLY, 1 GA X 14" SOLENOID TO POSITIVE CONTACT	036307 ²	1	
27	BOLT, 1/2-13 X 1" HEX HEAD GRADE 8	F05008-128 ¹	1	
28	NUT, 1/2-13 HEX NYLON HALF NUT	F05010-127 ¹	1	
29	PLATE, HLT TRAVEL	025745	1	
30	DECAL, BEFORE TOWING CAUTION	P11809	1	

¹ Axle Mount Plates 048269 modified and one bolt and lock nut replaced HLA Rev. A3.00 to eliminate interference with turner side support connecting rod.

² Solenoid, mounting hardware and cables added HLA Rev. A3.00 with introduction of dual-function hydraulics for manual sawmills.

SECTION 12 ACCESSORIES

LT30/LT40 Super

REF	DESCRIPTION	MASTER	
	LATHE-MIZER (SEE MANUAL)	M1337	
	LATHE-MIZER TENON KIT (SEE MANUAL)	M1308	
	RS2 RESAW (SEE MANUAL)	M1624	
	SHINGLE LAP SIDER (SEE MANUAL)	M903	

13 Trailers

SECTION 13 TRAILERS

LT30/LT40 Super

REF	DESCRIPTION	MASTER	
	ELECTRIC BRAKE TRAILER OPTION (SEE MANUAL)	M796	
	SURGE BRAKE TRAILER OPTION (SEE MANUAL)	M794	

SECTION 14 MISCELLANEOUS

14.1 Replacement Manuals



REF	DESCRIPTION (◆ Indicates Parts Available In Assemblies Only)	PART #	QTY.
Wood-Mizer Product Information			
1	ALL-PRODUCTS CATALOG	PS750	1
Basic Sawmill Manuals			
2	TRU-SHARP BLADE HANDBOOK	M600	1
3	WOOD-MIZER GENERAL INFORMATION	M601	1
4	LT40 SUPER OPERATOR'S MANUAL	M1647	1
5	LT40 SUPER PARTS MANUAL	M1646	1
Power Option Manuals			
6	E25 MOTOR OPTION MANUAL	M772	1
Trailer Option Manuals			
7	ELECTRIC BRAKE TRAILER OPTION	M796	1
8	SURGE BRAKE TRAILER OPTION	M794	1
Miscellaneous Option Manuals			
9	MANUAL WINCH OPTION MANUAL	M619-23	1
10	LOG TURNER OPTION MANUAL	M620	1
11	MANUAL TOE BOARD OPTION MANUAL	M627	1
12	SHINGLE/LAPSIDER OPTION MANUAL	M621	1
13	OPERATOR'S SEAT OPTION MANUAL	M613	1
14	RESAW ATTACHMENT OPTION MANUAL	M263	1
15	BED EXTENSION OPTION MANUAL	M294	1
16	MKII DEBARKER ATTACHMENT OPTION MANUAL	M546	1
17	ACCUSET 2 OPTION MANUAL	M1517	1
18	LASER SIGHT OPTION MANUAL	M679	1
19	AUTOCLUTCH OPTION MANUAL	M883	1
20	LUBE-MIZER OPTION MANUAL	M885	1
21	LATHE-MIZER OPTION MANUAL	M1337	1

14

Miscellaneous *Replacement Manuals*

Electrical Diagrams			
22	E25 ELECTRICAL INFORMATION	M863	1

14.2 Tools

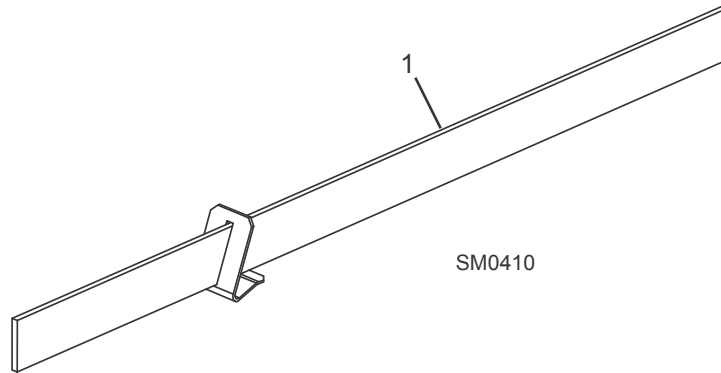

REF	DESCRIPTION (◆ Indicates Parts Available In Assemblies Only)	PART #	QTY.	
1	ALIGNMENT TOOL, BLADE GUIDE	LTBGAT	1	

INDEX

B

battery box 7-13

bed rails
front/rear 10-1
middle front 10-3
middle rear 10-4
pivot 10-9

blade guide arm 2-9
drive 2-7

blade guides
drive side 2-4
idle side 2-1
throat screw 4-1

blade wheels
drive side 3-1
idle side 3-3

board return 4-9

board return table 10-8

brake assembly 4-8

C

clutch lever 4-3

clutch mount 4-7

control box 7-1, 7-3, 7-5
circuit breakers 7-7, 7-8
drum switches 7-6
front panel & harnesses 7-9, 7-11

covers
blade housing 4-16
drive belt 4-20

D

debarker wire box/hole plugs 4-22

decals
frame 10-14
saw head 4-18, 4-19

E

engine options 5-1

F

feed chain 9-5

H

hydraulic
control box 11-2, 11-4
hoses 11-1
loader/turner misc. 11-14
power strip 11-6

L

legs
stationary 10-6

log clamp 10-15

log loading ramps 10-16

M

manuals 14-1, 14-3

O

options, accessories and trailers 6-1, 12-16, 13-1

outfeed table option 10-17

P

parts list

how to use 1-1

power feed 9-3

S

sawdust chute 4-21

side supports 10-11

T

tensor de hoja 3-4

track rollers

lower 9-6

upper 9-1

U

up/down

blade scales 8-2

chain & sprockets 8-4

drive 8-7

motor 8-6

saw head mount 8-1

W

water lube

bottle/tray 4-11, 4-12, 4-14

valve 4-2