

Wood-Mizer

**1996
Standard Trailer Option**

Operator's Manual

Form #665

Table of Contents

Section-Page

SECTION 1	SAFETY & GENERAL INFORMATION	1-1
SECTION 2	STANDARD HITCH OPERATION	2-1
SECTION 3	STANDARD TRAILER MAINTENANCE	3-1
SECTION 4	PARTS LISTS	4-1
4.1	Trailer Hitch Assembly	4-1
4.2	Trailer Axle Assembly	4-2
4.3	Outrigger Assembly (Long)	4-4
4.4	Outrigger Assembly (LT25L/LT40 Rear)	4-6
4.5	Outrigger Assembly (Short Front).....	4-8
4.6	Outrigger Assembly (Short Rear).....	4-10
4.7	Log Loading Ramps	4-12
4.8	Trailer Lights	4-13

SECTION 1 SAFETY & GENERAL INFORMATION



This symbol calls your attention to instructions concerning your personal safety. Be sure to observe and follow these instructions. This symbol accompanies a signal word. The word **DANGER** refers to hazards that can cause death or serious, irreversible personal injury. The word **WARNING** suggests a safety hazard that can cause personal injury. **CAUTION** refers to hazards that can cause damage to the equipment or property only.

Read all safety instructions before operating this equipment and observe all safety warnings!



DANGER! Make sure hitch bracket is securely fastened around ball before towing the sawmill. Ball should be completely engaged by the hitch bracket and securely locked in place.

DANGER! Do not use eyebolts for safety chain hook-up. Safety chains should be hooked to bumper of vehicle so that each chain would pull the trailer equally in the event the hitch became disengaged.

DANGER! Be sure that the hitch and safety chains are secure before towing the sawmill.



WARNING! Always check trailer tires for proper inflation before towing sawmill.



CAUTION! Always keep away from trailer axle to avoid being caught between the axle and moving saw carriage.

IMPORTANT! It is always the owner's responsibility to comply with all applicable federal, state and local laws, rules and regulations regarding the ownership, operation and towing of your Wood-Mizer sawmill. All Wood-Mizer mill owners are encouraged to become thoroughly familiar with these applicable laws and comply with them fully while using or towing the mill.

SECTION 2 STANDARD HITCH OPERATION

1. Pull the mill behind the towing vehicle and place the hitch over a 2" ball on your vehicle. The hitch ball should be solid (not two-piece) with a rating of at least 3500 pounds (1588 kg). The hitch should be correctly mounted to the towing vehicle so that it will be able to pull this type of load. Flip the locking handle downward, being sure the bracket underneath firmly clamps around the ball. Secure the locking handle with the safety pin.

 **DANGER!** Make sure hitch bracket is securely fastened around ball before towing the sawmill. Ball should be completely engaged by the hitch bracket and securely locked in place.

See Figure 2-1.

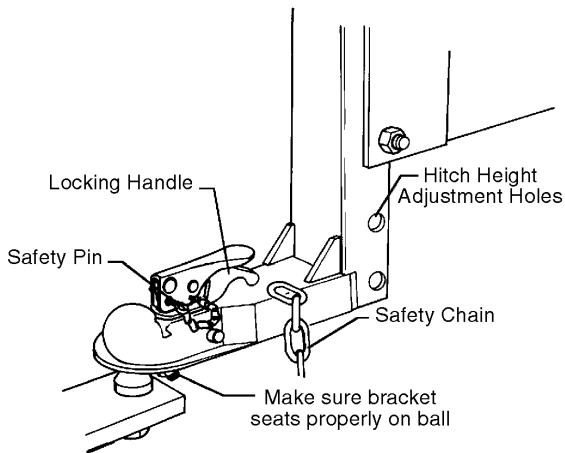

FIG. 2-1

2. Cross the safety chains underneath the hitch and hook to the vehicle. The chains should be connected so that there is still slack in the chains when the vehicle is turned sharply in either direction.



DANGER! Do not use eyebolts for safety chain hook-up. Safety chains should be hooked to bumper of vehicle so that each chain would pull the trailer equally in the event the hitch became disengaged.

3. Connect the vehicle running lights to the sawmill pigtail. Check signals and brake lights.
4. Raise the front outrigger. Recheck that all loose items are removed or secured (such as Resaw Option, Shingle/Lapsiding Option, cant hooks, etc.)

SECTION 3 STANDARD TRAILER MAINTENANCE

1. Clean and repack the trailer axle wheel bearings with lithium grease every 12 months or 12,000 miles (19,308 km), whichever comes first.
2. Make sure that the trailer tires are correctly inflated to the pressure shown on the tire.



WARNING! Always check trailer tires for proper inflation before towing sawmill.

SECTION 4 PARTS LISTS

4.1 Trailer Hitch Assembly				
REF	DESCRIPTION (◆ Indicates Parts Available In Assemblies Only)	PART #	QTY.	
1	HITCH, STANDARD TRAILER	W04258	1	
2	Chain, Hitch Latch Safety	M05058	1	
3	BOLT, 5/8-11 X 5 1/2" HEX HEAD GRADE 5	F05009-11	2	
4	NUT, 5/8-11 HEX LOCK	F05010-4	2	
	TOWING EXTENSION KIT (NOT SHOWN, OPTIONAL)	K12571	1	
	Bolt, 5/8-11 x 2 1/2" Hex Head Grade 5	F05009-20	2	◆
	Washer, 5/8" Split Lock	F05011-27	2	
	Washer, 5/8" SAE Flat	F05011-5	2	
	Bracket, Safety Chain Bumper	S12289-N	2	◆
	Nut, 5/8-11 Free Hex	F05010-5	2	

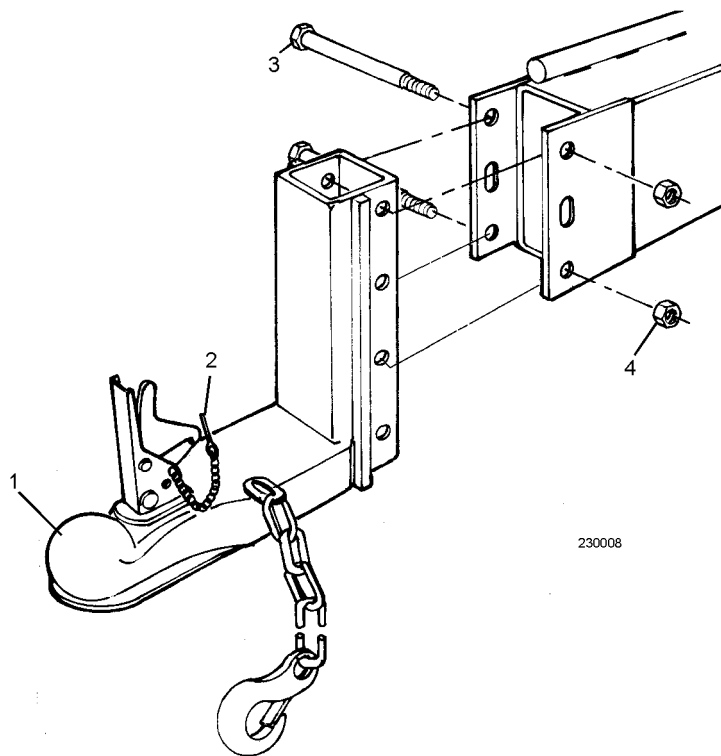

FIG. 4-1

4

Parts Lists Trailer Axle Assembly

4.2 Trailer Axle Assembly				
REF	DESCRIPTION (◆ Indicates Parts Available In Assemblies Only)	PART #	QTY.	
	AXLE FRAME ASSEMBLY, STANDARD	A09752	1	
1	Frame, Trailer Axle	W09751	1	◆
2	Axle, 3500 Lb. With Springs	P09772	1	
3	Spring, 2000 Lb. Dexter Leaf	P09612 ¹	1	
4	Spring, 2500 Lb. Dexter Leaf	014586 ²	1	
	Bearing Kit, Sawmill Axle Spindle	K07549	1	
5	Bearing, Dexter #L44649	P22573-1	1	◆
6	Bearing, Dexter #L68149	P22572-1	1	◆
7	Race, Inner Dexter #L68111	P22572-2	1	◆
8	Race, Outer Dexter #L44610	P22573-2	1	◆
9	Seal, 13" Wheel Bearing Dust	P07554	1	
10	Cap, Wheel Bearing Dust	P04493	2	
11	Wheel Assembly, LT185R14 D (Silver Rim)	014677 ³	2	
	Wheel Assembly, ST205/75 D14 (White Rim)	P04468-2 ⁴	2	
12	PLATE, TRAILER AXLE SHACKLE	M07528	4	
13	BOLT, 9/16-8 X 3" SHACKLE	P04644	6	
14	NUT, 9/16-8 SHACKLE	P04643	6	
15	NUT, 1/2-20 WHEEL LUG	P04646	10	
16	BOLT, 1/2-13 X 4" HEX HEAD GRADE 2	F05008-26	4	
17	WASHER, 1/2" EXTERIOR STAR	F05011-39	4	
18	WASHER, 1/2" SAE FLAT	F05011-2	4	
19	NUT, 1/2-13 HEX NYLON LOCK	F05010-8	4	
20	FENDER, TRAILER WHEEL	W11452 ⁵	2	
21	DECAL, FENDER DAMAGE CAUTION	S11761	2	
22	PIN, 5/16" X 1" DETAINING	F05012-45 ⁶	2	

¹ Use as a replacement for originally supplied 009613 1750 Lb. Dexter Leaf Spring.

² Use as a replacement for originally supplied P09612 2000 Lb. Dexter Leaf Spring.

³ Replaces 014495 ST205/75D14C wheel assembly originally supplied after 6/96. Optional: Upgrade *both* wheels with Goodyear wheel assemblies 015987 to ensure proper mill tracking. (The wheel types have slightly different diameters.)

⁴ White rims supplied until 6/96. Optional: Upgrade *both* wheels with Goodyear wheel assemblies 015987 to ensure proper mill tracking. (The wheel types have slightly different diameters.)

⁵ Added hole for detaining pin to fender and fender mounting bracket (LT30/LT30 Super F6.01+, LT40/LT40 Super F7.01+, LT30HD/LT40HD/LT30HD Super/LT40HD Super F9.01+).

⁶ Added to secure fender to fender mounting bracket (applies to LT30/LT30 Super F6.01+, LT40/LT40 Super F7.01+, LT30HD/LT40HD/LT30HD Super/LT40HD Super F9.01+).

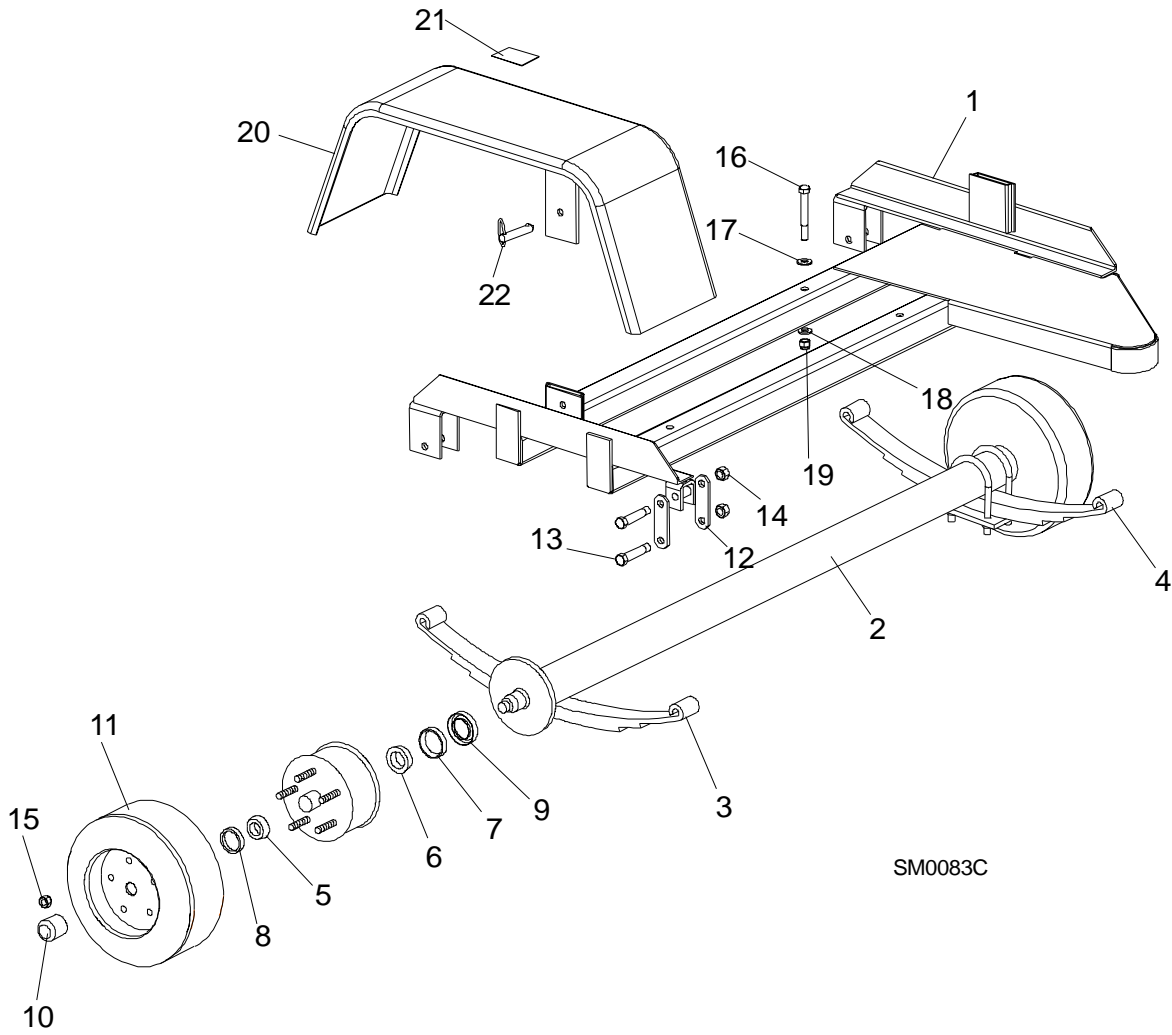

FIG. 4-2

4

Parts Lists

Outrigger Assembly (Long)

4.3 Outrigger Assembly (Long)				
REF	DESCRIPTION (◆ Indicates Parts Available In Assemblies Only)	PART #	QTY.	
	OUTRIGGER ASSEMBLY, LONG	012997	2/3	
1	Guide, Long Outrigger Guide	012996	1	
2	Leg, Outrigger	W07537	1	
3	Cap, Outrigger Leg	P09926	1	
4	Spring, Outrigger Pin	P04282 ¹	1	
5	Washer, 9/16" SAE Flat	F05011-8 ¹	2	
	Pin Kit, Outrigger Pull	A12232 ¹	1	
6	Pin, Outrigger Pull	S12261 ¹	1	◆
7	Pin, 5/16" x 2 1/2" Roll	F05012-47 ¹	1	
8	Pin, 1/8" x 1" Cotter	F05012-1 ¹	1	
9	BOLT, 3/8-16 X 5" CARRIAGE HEAD	F05007-113 ²	8/12	
	BOLT, 3/8-16 X 5" HEX HEAD GRADE 2	F05007-5 ²	8/12	
10	WASHER, 3/8" SAE FLAT	F05011-3	8/12	
11	NUT, 3/8-16 HEX NYLON LOCK	F05010-10	8/12	

¹ Outrigger pin and hardware replaced with 3/4" diameter pin and hardware 10/98. Outrigger assembly includes updated outrigger pin parts ([See Section 4.9](#)).

² Carriage bolts F05007-113 used on LT25 Rev. C1596+, LT30 Rev. F6822+, LT30 Super Rev. F9040+, LT40 Rev. F7749+, LT40 Super Rev. F7010, LT30HD Rev. F9535+, LT30HD Super Rev. F9040+, LT40HD Rev. F9824+, LT40HD Super Rev. F9437+. Use hex head bolts F05007-5 on prior revisions.

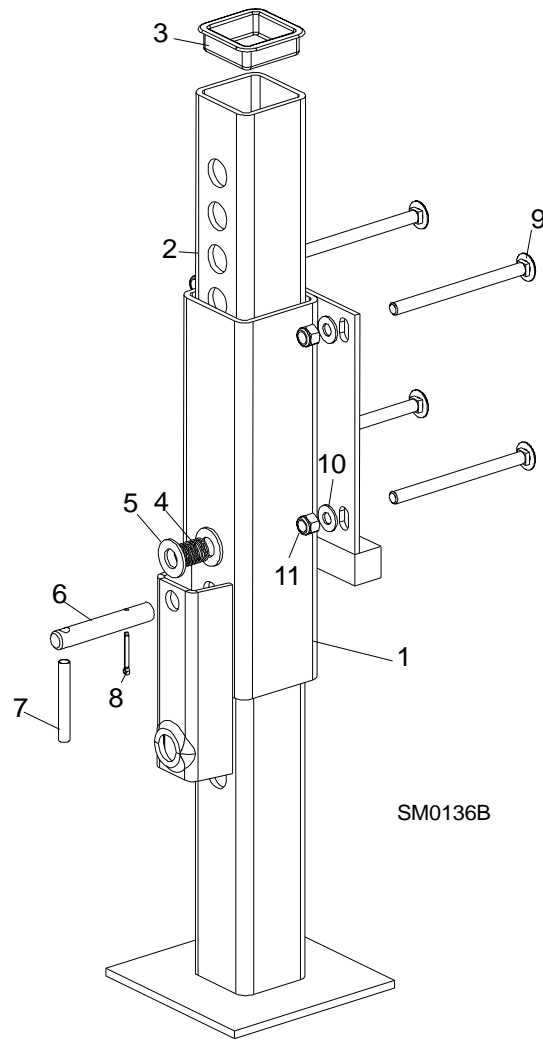

FIG. 4-3

4

Parts Lists

Outrigger Assembly (LT25L/LT40 Rear)

4.4 Outrigger Assembly (LT25L/LT40 Rear)				
REF	DESCRIPTION (◆ Indicates Parts Available In Assemblies Only)	PART #	QTY.	
	LEG KIT, REAR OUTRIGGER RETROFIT	A12076	1	
	Outrigger Assembly, LT40 Rear	A12083 ¹	1	
1	Guide, Short Rear Outrigger Guide	W12082	1	
2	Leg, Outrigger	W07537	1	
3	Cap, Outrigger Leg	P09926	1	
4	Spring, Outrigger Pin	P04282 ²	1	
5	Washer, 9/16" SAE Flat	F05011-8 ¹	2	
	Pin Kit, Outrigger Pull	A12232 ¹	1	
6	Pin, Outrigger Pull	S12261 ¹	1	◆
7	Pin, 5/16" x 2 1/2" Roll	F05012-47 ¹	1	
8	Pin, 1/8" x 1" Cotter	F05012-1 ¹	1	
9	Bolt, 3/8-16 X 1" Hex Head Grade 2	F05007-7	4	
10	Nut, 3/8-16 Hex Nylon Lock	F05010-10	4	
	Instruction Sheet, Rear Outrigger Leg Retrofit Kit Installation	A12076-411	1	

¹ Rear outrigger added to LT40 #518 and LT40HD #849 and later (4/92). Use A12076 to retrofit all previous LT40/LT40HD models with outrigger assembly and mounting hardware.

² Outrigger pin and hardware replaced with 3/4" diameter pin and hardware 10/98. Outrigger assembly includes updated outrigger pin parts ([See Section 4.9](#)).

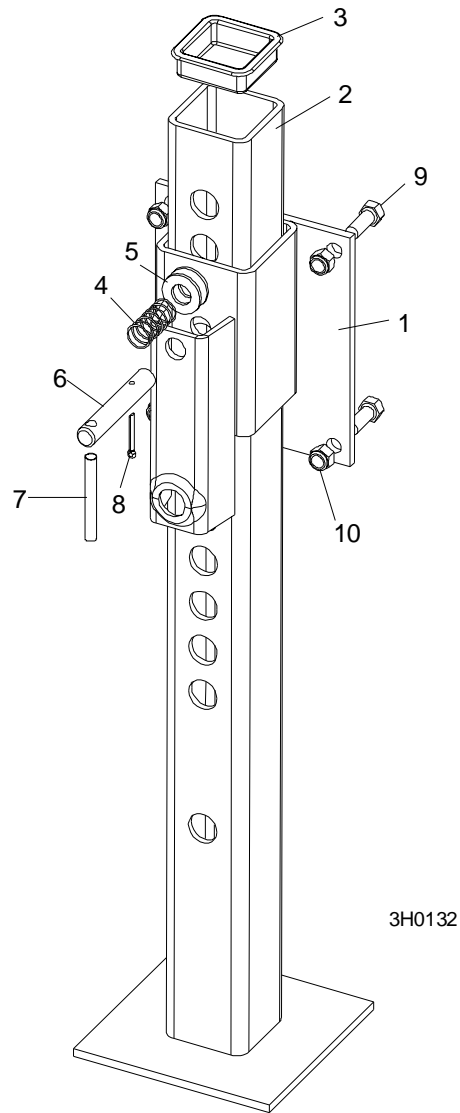

FIG. 4-4

4

Parts Lists

Outrigger Assembly (Short Front)

4.5 Outrigger Assembly (Short Front)				
REF	DESCRIPTION (◆ Indicates Parts Available In Assemblies Only)	PART #	QTY.	
	OUTRIGGER ASSEMBLY, SHORT FRONT	A04278	1	
1	Guide, Short Front Outrigger Guide	W09012	1	
2	Leg, Outrigger	W07537	1	
3	Cap, Outrigger Leg	P09926	1	
4	Spring, Outrigger Pin	P04282 ¹	1	
5	Washer, 9/16" SAE Flat	F05011-8 ¹	2	
	Pin Kit, Outrigger Pull	A12232 ¹	1	
6	Pin, Outrigger Pull	S12261 ¹	1	◆
7	Pin, 5/16" x 2 1/2" Roll	F05012-47 ¹	1	
8	Pin, 1/8" x 1" Cotter	F05012-1 ¹	1	
9	BOLT, 3/8-16 X 1" HEX HEAD GRADE 2	F05007-7	4	
10	NUT, 3/8-16 HEX NYLON LOCK	F05010-10	4	

¹ Outrigger pin and hardware replaced with 3/4" diameter pin and hardware 10/98. Outrigger assembly includes updated outrigger pin parts ([See Section 4.9](#)).

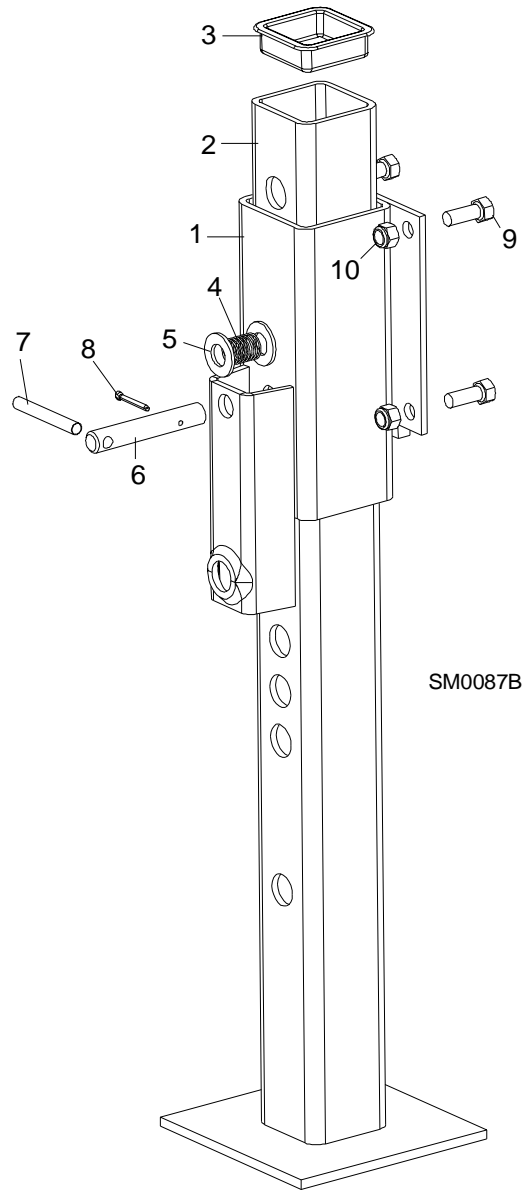

FIG. 4-5

4

Parts Lists

Outrigger Assembly (Short Rear)

4.6 Outrigger Assembly (Short Rear)				
REF	DESCRIPTION (◆ Indicates Parts Available In Assemblies Only)	PART #	QTY.	
	OUTRIGGER ASSEMBLY, SHORT REAR	A09475	1	
1	Guide, Short Rear Outrigger Guide	W09474	1	
2	Leg, Outrigger	W07537	1	
3	Cap, Outrigger Leg	P09926	1	
4	Spring, Outrigger Pin	P04282 ¹	1	
5	Washer, 9/16" SAE Flat	F05011-8 ¹	2	
	Pin Kit, Outrigger Pull	A12232 ¹	1	
6	Pin, Outrigger Pull	S12261 ¹	1	◆
7	Pin, 5/16" x 2 1/2" Roll	F05012-47 ¹	1	
8	Pin, 1/8" x 1" Cotter	F05012-1 ¹	1	
9	BOLT, 3/8-16 X 1" HEX HEAD GRADE 2	F05007-7	4	
10	NUT, 3/8-16 HEX NYLON LOCK	F05010-10	4	
11	HANDLE, OUTRIGGER LIFT	S04827	1	

¹ Outrigger pin and hardware replaced with 3/4" diameter pin and hardware 10/98. Outrigger assembly includes updated outrigger pin parts ([See Section 4.9](#)).

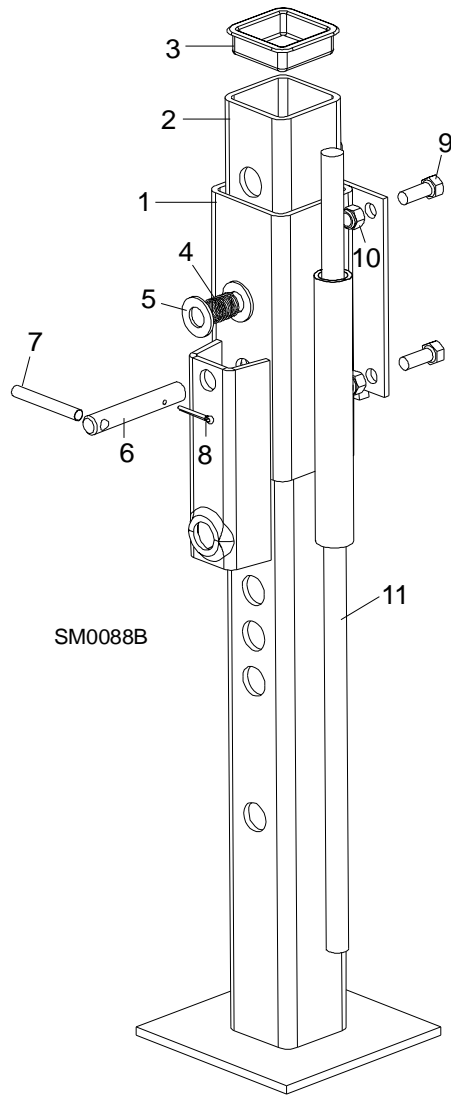

FIG. 4-6

4

Parts Lists Log Loading Ramps

4.7 Log Loading Ramps				
REF	DESCRIPTION (◆ Indicates Parts Available In Assemblies Only)	PART #	QTY.	
	RAMP KIT, LOG LOADING WITH RETAINERS	K09466	1	
1	Ramp, Log Loading	W09014	2	
	Retainer Kit, Log Ramp	K09810	2	
2	Retainer, Log Ramp	W09413	1	◆
3	Spring, Log Ram Retainer	P09335	1	
4	Washer, 5/8" I.D. x .100" Thick Nylon	F05011-19	1	
5	Pin, 3/16" x 1" Roll	F05012-11	1	

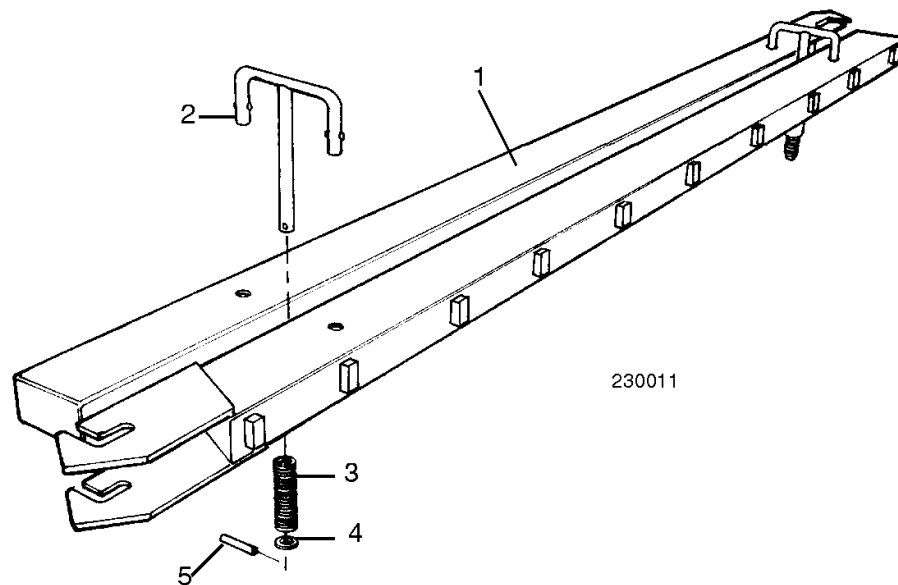

FIG. 4-7

4.8 Trailer Lights				
REF	DESCRIPTION (◆ Indicates Parts Available In Assemblies Only)	PART #	QTY.	
1	PLUG, TRAILER LIGHT MALE	P04159	1	
2	PLUG, TRAILER LIGHT FEMALE	P04983	1	
3	LIGHT ASSEMBLY, TRAILER TAIL	P04294	2	
4	Lens, Grote Tail Light #90012	P12509	1	
5	Bulb, #1157 Trailer Light	P04481	1	
6	Clip, Grote Tail Light Retainer	P12510	1	
7	Gasket, Grote Tail Light Lens	P12511	1	
8	LIGHT, LICENSE PLATE	P09928	1	
	LIGHT, RECTANGLE RED RUNNING	P12905	1	
	LIGHT, RECTANGLE AMBER RUNNING (NOT SHOWN)	P12906	1	
9	Lens, Rectangle Red Running Light	P12921	1	
	Lens, Rectangle Amber Running Light	P12922	1	
10	Bulb, Rectangle Running Light Replacement	P12923	1	
11	LIGHT, ROUND RED RUNNING	P12913	1	
	LIGHT, ROUND AMBER RUNNING (NOT SHOWN)	P12914	1	
	Light, Round Red Running Replacement	P12917	1	
	Light, Round Amber Running Replacement	P12918	1	
	Pigtail, Round Running Light Replacement	P12920	1	
	Grommet, Round Running Light Replacement	P12919	1	

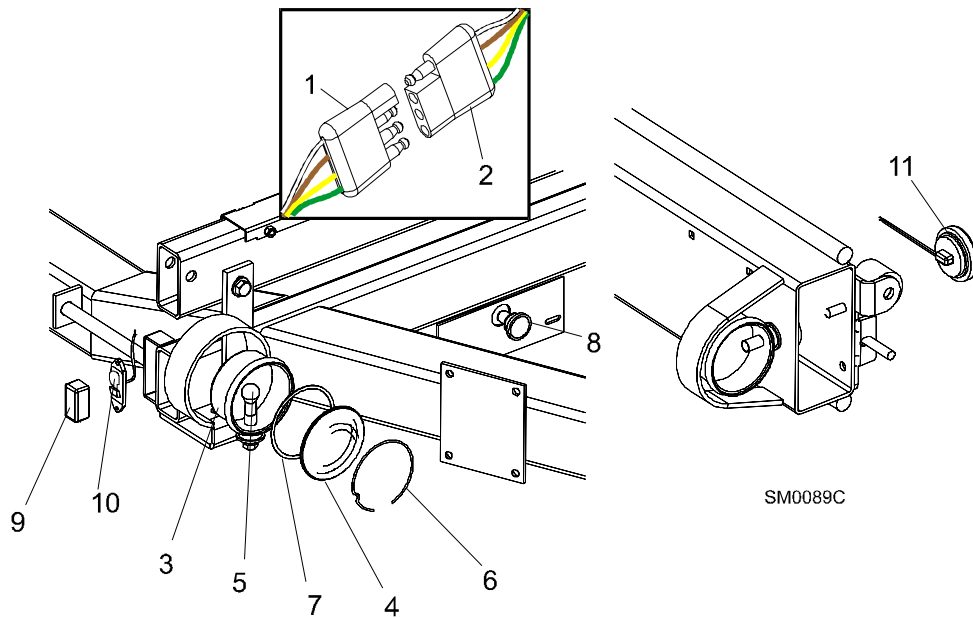

FIG. 4-8

4

Parts Lists

Outrigger Pin Hardware (3/4" Dia.)

4.9 Outrigger Pin Hardware (3/4" Dia.)				
REF	DESCRIPTION (◆ Indicates Parts Available In Assemblies Only)	PART #	QTY.	
1	SPRING, OUTRIGGER PIN	016145	1	
2	WASHER, 3/4" SAE FLAT	F05011-62	2	
	PIN KIT, 3/4" OUTRIGGER PULL	016148 ¹	1	
3	Pin, 3/4" Outrigger Pull	016147	1	◆
4	Pin, 5/16" X 2 1/2" Roll	F05012-47	1	
5	PIN, 1/8" X 1 1/4" COTTER	F05012-59	1	

¹ 3/4" diameter outrigger pin and hardware used with outrigger assemblies supplied after 10/98. See outrigger and hitch assemblies for original 9/16" outrigger pins and parts.

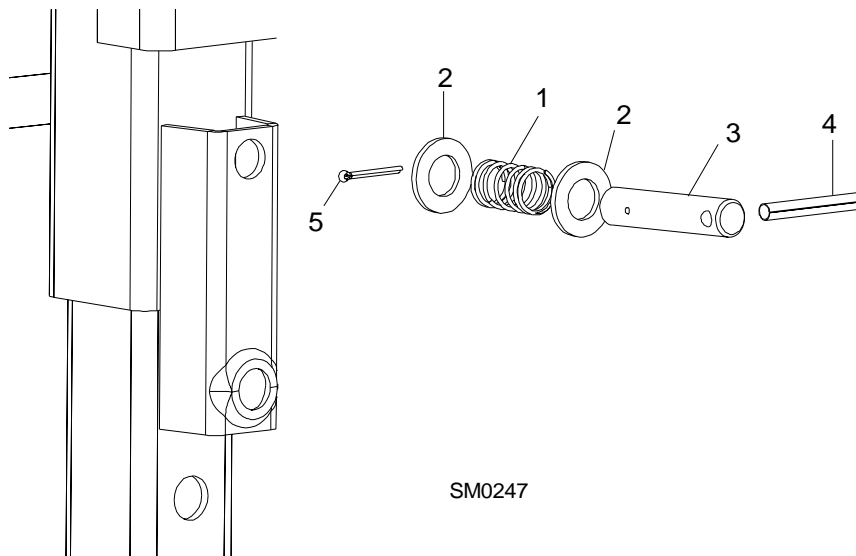

FIG. 4-9