

40HST Stationary Trailer

Safety, Operation, Maintenance
& Parts Manual

Stationary Kit, LT40HD/70

J1.01

Safety is our #1 concern!

Form #2497

Models Effected:

All LT40HD except:

LT40HDG26

LT40HDG26W

All LT50HD

All LT70HD except:

All LT70 DCS models*

All LT70 Super Hydraulics**

*see form 2501, 70ST-DCS

**see form 2500, 70ST-R



WARNING! Read and understand this manual before using this machine.

California

Proposition 65 Warning



WARNING: Breathing gas/diesel engine exhaust exposes you to chemicals known to the State of California to cause cancer and birth defects or other reproductive harm.

Always start and operate the engine in a well-ventilated area.
If in an enclosed area, vent the exhaust to the outside.
Do not modify or tamper with the exhaust system.
Do not idle the engine except as necessary.

For more information go to www.P65warnings.ca.gov.



WARNING: Drilling, sawing, sanding or machining wood products can expose you to wood dust, a substance known to the State of California to cause cancer. Avoid inhaling wood dust or use a dust mask or other safeguards for personal protection.

For more information go to www.P65Warnings.ca.gov/wood.

Active Patents assigned to Wood-Mizer, LLC

Wood-Mizer, LLC has received patents that protect our inventions which are a result of a dedication to research, innovation, development, and design. Learn more at: woodmizer.com/patents

©June 17, 2024 Wood-Mizer LLC

Printed in the United States of America, all rights reserved. No part of this manual may be reproduced in any form by any photographic, electronic, mechanical or other means or used in any information storage and retrieval system without written permission from

Wood-Mizer, LLC
8180 West 10th Street
Indianapolis, Indiana 46214

SECTION 1 TIRE SAFETY

1.1 Tire labeling 1-1
 Tire markings 1-1
 Identifying tires 1-1
 Tire Identification Number 1-1
 1.2 Recommended tire inflation pressure 1-1
 Recommended cold tire inflation pressure 1-1
 The vehicle tire inflation pressure label and location 1-2
 Consequences of tire under-inflation 1-2
 Proper inflation 1-2
 1.3 Glossary 1-3
 1.4 Tire care, maintenance, and safety practices 1-4
 1.5 Vehicle load limits 1-4

SECTION 2 REPLACEMENT PARTS

2.1 Floor Locations 2-1
 2.2 Overview 2-2
 2.3 Hitch and Electrical Box 2-3
 2.4 Leg, Transport Only 2-4
 2.5 Leg, Stationary Front 2-5
 2.6 Stationary Leg Front 2-6
 2.7 Leg, Stationary Right 2-7
 2.8 Leg, Stationary Left 2-8
 2.9 Axle Assembly 2-9
 2.10 Trailer Lights (2008 to Current) 2-10
 2.11 Trailer Lights (Prior to 2007) 2-11

SECTION 3 ELECTRICAL INFORMATION

3.1 Electric Brake Wiring Diagram (2008-Present) 3-1
 3.2 Wiring Diagram (1997-2008) 3-2

SECTION 1 TIRE SAFETY

1.1 Tire labeling

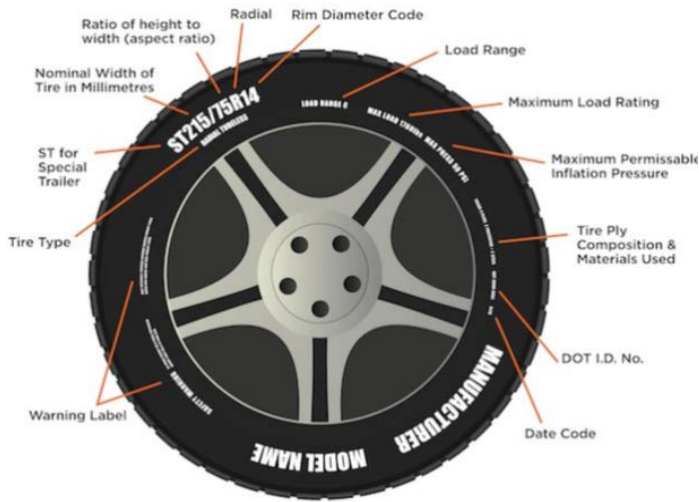

Tire markings

TIRE CLASS AND SIZE: (Example: ST215/75R14)

- **ST** stands for Special Trailer tire. ST trailer tires are built to tow heavy loads, withstand excessive heat, and reduce sway.
- **215** is tire width in millimeters;
- **75** is the aspect ratio, or ratio of height to width;
- **R** is type of construction (radial, in the example)
- **14** is rim diameter in inches.

TIRE TYPE Below the tire size is either 'radial' or 'bias.' Radial tires (or 'radial-ply tires') are constructed with polyester and/or nylon plies that run across the tire perpendicularly, and sometimes include steel belts that run under the tread. Bias-ply tires Bias-ply cords layer in a criss-cross pattern from sidewall to sidewall, and they are also sometimes reinforced with a steel belt.

LOAD RANGE Load range indicates the type of load a tire is designed to support at a specific inflation pressure. Trailer tires typically have C, D, or E load ranges. A load range 'C' tire, for example, is at its peak load capacity—possibly 1600 pounds—when it's inflated to its maximum pressure of 50 PSI. A load range 'C' tire at 25 PSI might be able to support a load of 990 pounds, while at 40 PSI, that capacity could be 1300 pounds.

MAXIMUM LOAD RATING Load rating or load index indicates the weight a tire can safely carry at its maximum air pressure. In the example, at its maximum air pressure of 50 PSI (cold), a load range 'C' tire might have a load rating of 1760 pounds.

MAXIMUM PRESSURE Maximum pressure (when the tires are cold) needed for the tires to carry the maximum load; measured in PSI.

Identifying tires

Tires are required to have a Tire Identification Number (TIN) begin with the letters "DOT," followed by eight to thir-

teen characters that can be used to identify the manufacturing location, tire size, and manufacturer's specifications, along with the week and year the tire was manufactured. DOT Tire Identification Numbers are commonly but erroneously referred to as the tire's serial number, but it actually identifies production *batches*, not individual items.

Regulations also require the entire DOT Tire Identification Number to be branded on one sidewall, while only the letters "DOT" and the first digits of the Tire Identification Number must be branded onto the opposite sidewall. Therefore it is possible to see a Tire Identification Number that appears incomplete, yet simply requires looking at the tire's other sidewall to find the complete Tire Identification Number.

Tire Identification Number

DOT AND DATE CODES Department of Transportation identifier will include 10-12 numbers following 'DOT.' The first six to eight numbers indicate the manufacturer's code, where the tire was manufactured and the tire size.

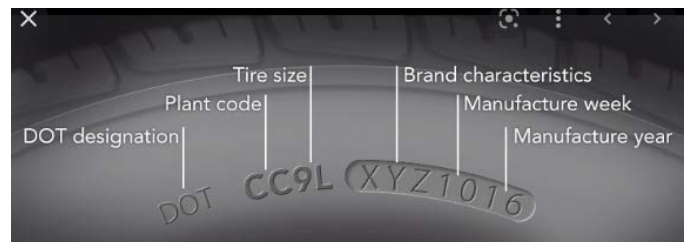

1.2 Recommended tire inflation pressure

Recommended cold tire inflation pressure

The cold inflation pressure is the contained air pressure of a tire that would occur at an indexed temperature of 68°F or 20°C. This indexed temperature is based on the ideal ambient operating conditions for the tire.

Ambient air temperature pressure adjustment tables:

TABLE 1-1 - IMPERIAL MEASUREMENTS

Listed Pressure	10 psi	20 psi	30 psi	40 psi	50 psi	60 psi	70 psi	80 psi	90 psi	100 psi
104°	11.7	22.4	33.1	43.7	54.4	65.1	75.8	86.5	97.1	107.8
86°	10.8	21.2	31.5	41.9	52.2	62.5	72.9	83.2	93.6	103.9
68°	10.0	20.0	30.0	40.0	50.0	60.0	70.0	80.0	90.0	100.0
50°	9.2	18.8	28.5	38.1	47.8	57.5	67.1	76.8	86.4	96.1
32°	8.3	17.6	26.9	36.3	45.6	54.9	64.2	73.5	82.9	92.2
14°	7.5	16.4	25.4	34.4	43.4	52.4	61.3	70.3	79.3	88.3
-4°	6.6	15.3	23.9	32.5	41.2	49.8	58.4	67.1	75.7	84.3
-22°	5.8	14.1	22.4	30.7	39.0	47.3	55.5	63.8	72.1	80.4
-40°	4.9	12.9	20.8	28.8	36.8	44.7	52.7	60.6	68.6	76.5

METRIC MEASUREMENTS

Listed Pressure	69 kPa	138 kPa	207 kPa	276 kPa	345 kPa	414 kPa	483 kPa	551 kPa	620 kPa	689 kPa
40°	81	154	228	301	375	449	522	596	670	743
30°	75	146	217	289	360	431	502	574	645	716
20°	69	138	207	276	345	414	483	551	620	689
10°	63	130	196	263	329	396	463	529	596	662
0°	57	122	186	250	314	378	443	507	571	635
-10°	52	113	175	237	299	361	423	485	546	608
-20°	46	105	165	224	284	343	403	462	522	581
-30°	40	97	154	211	269	326	383	440	497	554
-40°	34	89	144	199	253	308	363	418	473	527

The vehicle tire inflation pressure label and location

The generic bilingual tire pressure label appears as in FIG. 1-3. The label on the vehicle has information specific to the trailer filled in

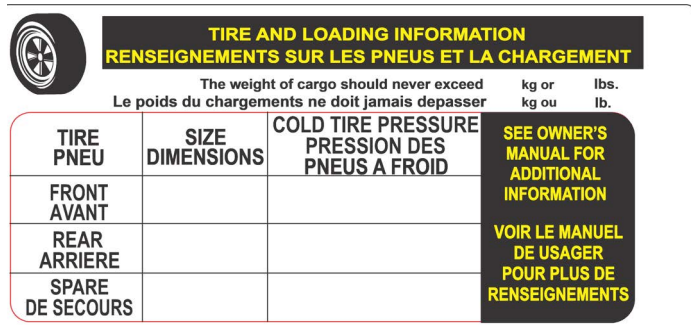

The label is placed near the VIN placard, toward the **front left side** of the trailer.

General area of VIN placard and tire pressure label for Wood-Mizer mill trailers.

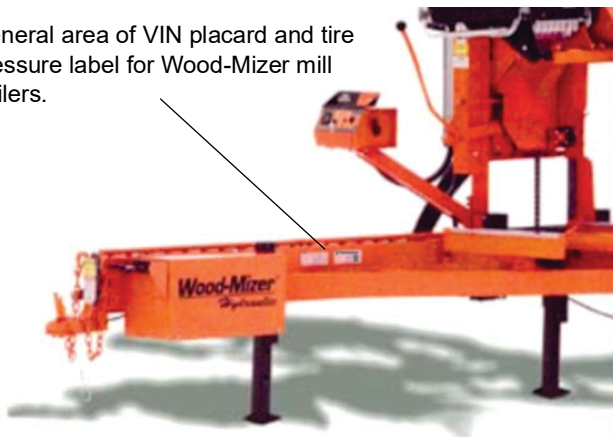

Consequences of tire under-inflation

Underinflated tires and overloaded vehicles are a major cause of tire failure. Tire inflation effects a vehicle's

- steering,
- stopping,

- traction, and
- load-carrying capability.

To avoid flat tires and other types of tire failure, you should

- maintain proper tire pressure,
- observe tire and vehicle load limits,
- avoid road hazards, and
- regularly inspect your tires.

Proper inflation

CHECK TIRE PRESSURE

Use a tire pressure gauge, which you can be purchased at most service stations or auto parts stores. Check the pressure when the tires are **COLD**, as the friction from driving affects the pressure. If driven recently, wait at least three hours for the tires to cool down.



COMMON TIRE PRESSURE GAUGES

1. Remove the cap from the air valve on the tire, and put it somewhere you won't lose it.
2. Press the tire gauge against the open valve stem momentarily.
3. Read the air pressure gauge.
4. Compare this number with the recommended tire pressure.
5. Inflate/release air as needed.
6. Replace the tire's air valve cap.
7. Repeat this process for each tire.

INFLATE YOUR TRAILER'S TIRES

1. Park close enough to the air compressor so you can reach all tires with the hose.
2. If the valve caps are still on, remove them.
3. Press the hose nozzle down on the valve stem.

NOTE: You should notice the tire inflating and feel air flowing through the hose. If not, check to ensure

FIG. 1-4 the hose is securely placed on the valve stem.

4. Remove the hose fitting.
5. Check the air pressure as described above.
6. Repeat steps 3- 5 as needed until the tire is inflated to the correct psi.
7. Repeats steps 2-5 for the vehicle's other tires.

8. Once the tires are inflated properly, replace the valve caps.

RELEASE AIR FROM TIRES

Overinflated tires can lead to poor handling, such as skidding and hydroplaning.

1. Briefly press the small dot or bead on the back of the tire pressure gauge into the center of the valve stem on the tire.

NOTE: You should hear the air escaping the tire.

2. Use the gauge to check the tire pressure.
3. Repeat these steps until you've released enough air to reach the correct psi.

WHEN TO CHECK TIRE PRESSURE

Use Table 1-1 to adjust the recommended cold tire pressure to the ambient temperature. Check tire pressure monthly.

- Most tires may naturally lose air over time.
- Tires can lose air suddenly if you drive over a pothole or other object or if you strike the curb when parking.
- With radial tires, it is usually not possible to determine underinflation by visual inspection.

1.3 Glossary

ALPHA CHARACTER A single alphabetical character from A to Z.

BEAD SEPARATION A breakdown of bond between components in the bead area.

BEAD That part of the tire made of steel wires, wrapped or reinforced by ply cords, that is shaped to fit the rim.

CARCASS PLY A ply that extends to the beads.

CARCASS The tire structure, except tread and sidewall rubber.

CHUNKING The breaking away of pieces of the tread or sidewall.

COLD TIRE PRESSURE The air pressure in a tire at ambient temperature, **not having been driven for the at least 3 hours**.

CORD SEPARATION Cord parting away from adjacent rubber compounds.

CORD The strands that form the plies in the tire.

CRACKING Any parting within the tread, sidewall, or innerliner of the tire extending to cord material.

CURB WEIGHT The weight of a motor vehicle with standard equipment including the maximum capacity of fuel, oil, and coolant, and, if so equipped, air conditioning and additional weight of optional engine.

DEEP TREAD RADIAL A deep tread radial tire is one having a minimum tread depth of 14.3 mm (18/32 inch or 0.5625 inch) or greater.

DOT SYMBOL The letters "DOT" are part of the DOT serial number. This is the manufacturer's certification that the tire or rim meets or exceeds the requirements of FMVSS Nos. 110 and 139.

DOT TIRE IDENTIFICATION NUMBER Number appearing on the sidewall of the tire near the rim required by 49 CFR Part 574.5 which identifies the manufacturer's identification mark, tire size, tire type code and date of manufacture. See Fig. 1-2.

EXTRA LOAD TIRE A tire designed to operate at higher loads and at higher inflation pressures than the corresponding standard tire.

FIELDS Any group of letters and numbers that have significance or meaning.

GAWR The Gross Axle Weight Rating (GAWR) means the value specified by the vehicle manufacturer as the load-carrying capacity of a single axle system, as measured at the tire-ground interfaces.

GROOVE The space between two adjacent tread ribs.

GVWR The Gross Vehicle Weight Rating (GVWR) means the value specified by the manufacturer as the loaded weight of a single vehicle.

INNERLINER SEPARATION The parting of the innerliner from cord material in the carcass.

INNERLINER The layer(s) forming the inside surface of a tubeless tire that contains the inflating medium within the tire.

INTENDED OUTBOARD SIDEWALL (1) The sidewall that contains a whitewall, bears white lettering or bears manufacturer, brand, and/or model name molding that is higher or deeper than the same molding on the other sidewall of the tire; or (2) The outward facing sidewall of an asymmetrical tire having a particular side that must always face outward when mounted on a vehicle.

LIGHT VEHICLE TIRE A new, pneumatic, radial tire intended for use on motor vehicles (other than motorcycles and low speed vehicles) that have a gross vehicle weight rating (GVWR) of 10,000 pounds or less and were manufactured after 1975.

LOAD RATING The maximum load a tire is rated to carry for a given inflation pressure.

MAXIMUM LOAD RATING The load rating at the maximum permissible inflation pressure for that tire.

MAXIMUM INFLATION PRESSURE The maximum cold inflation pressure needed for your tire to support the weight of its **maximum load-carrying capacity**.

MEASURING RIM The rim on which a tire is fitted for physical dimension requirements.

NHTSA/OVSC National Highway Traffic Safety Administration, Office of Vehicle Safety Compliance (Canada).

OPEN SPLICE Any parting at any junction of tread, sidewalls, or innerliner that extends to cord material.

OUTER DIAMETER The overall diameter of an inflated new tire.

OVERALL WIDTH The linear distance between the exteriors of the sidewalls of an inflated tire, including elevations due to marking, decorations, or protective bands or ribs.

PLY A layer of rubber-coated parallel cords.

PLY SEPARATION A parting or rubber compound between adjacent plies.

PNEUMATIC TIRE A mechanical device made of rubber, chemicals, fabric, steel, or other materials, which, when mounted on an automotive wheel, provides the traction and contains the gas or fluid that sustains the load.

RADIAL PLY TIRE A pneumatic tire in which the ply cords that extend to the beads are laid at substantially 90° to the centerline of the tread.

RECOMMENDED INFLATION PRESSURE The cold inflation pressure provided on the Tire Information label and on the VIN tag.

REINFORCED TIRE A tire designed to operate at higher loads and at higher inflation pressures than the corresponding standard tire.

RESPONSIVE TEST A special test initiated through a complaint, field inspection, failed standard test, or COTR discretion. RIM A metal support for a tire or a tire and tube assembly upon which the tire beads are seated.

RIM DIAMETER Nominal diameter of the bead seat.

RIM SIZE DESIGNATION Rim diameter and width.

RIM TYPE DESIGNATION The industry or manufacturer's designation for a rim by style or code. RIM WIDTH Nominal distance between rim flanges.

SECTION WIDTH The linear distance between the exteriors of an inflated tire's sidewalls, excluding elevations due to marking, decoration, or protective bands.

SIDEWALL That portion of a tire between the tread and the bead.

SIDEWALL SEPARATION The parting of the rubber compound from the cord material in the sidewall.

SIZE FACTOR The sum of the section width and the outer diameter of a tire determined on the test rim.

SNOW TIRE A snow tire means a tire that attains a traction index equal to or greater than 110, compared to the ASTM E-1136 Standard Reference Test Tire, when using the snow traction test as described in ASTM F-1805-00, Standard Test Method for Single Wheel Driving Traction in a Straight Line on Snow- and Ice-Covered Surfaces, and which is marked with an Alpine Symbol specified in S5.5(i) of FMVSS No. 139 on at least one sidewall.

TREAD That portion of a tire that comes into contact with the road.

TREAD RIB A tread section running circumferentially around a tire.

TREAD SEPARATION Pulling away of the tread from the tire carcass.

TREADWEAR INDICATORS (TWI) Projections within the principal grooves designed to give a visual indication of the degree of wear of the tread.

UVW The Unloaded Vehicle Weight (UVW) is the weight of a vehicle with maximum capacity of all fluids necessary for vehicle operation, but without cargo, occupants, or accessories that are ordinarily removed from the vehicle when they are not in use.

VEHICLE NORMAL LOAD ON THE TIRE The vehicle normal load on the tire means that load on an individual tire that is determined by distributing to each axle its share of the curb weight, accessory weight, and normal occupant weight and dividing by 2.

1.4 Tire care, maintenance, and safety practices

1. Check your cold tire pressure at least once a month (See [Proper inflation](#))
2. Visually inspect your tires
 - 1). Check the tread at least once a month for excessive or uneven wear.
 - 2). Measure tread depth in three locations across the tire's tread: (1) outer edge, (2) center, and (3) inside edge.

NOTE: Accurate tread depth measurements are made with a simple tread depth gauge available at any parts store.
--Or you can use the quarter (coin) method. Insert a quarter into a tread groove with the top of Washington's head facing down. If the top of his head is not visible, your tires have at least 4/32" of tread and are fine for continued use. If you can see above the top of Washington's head, replace the tire.
 - 3). Inspect for over inflation: wear primarily in the center of the tread, with less wear at the tire's edges.
 - 4). Inspect for under inflation: wear primarily on both edges of the tire tread, with less wear in the center.
 - 5). Inspect for tread wear on one edge of the tire which occurs when the wheels are out of alignment.
 - 6). Inspect for erratic tread wear, "cupping," caused by the wheel out of balance, or suspension components need to be replaced.
 - 7). Inspect for raised portion of the tread or sidewall which may indicate that one of the belts in the tire carcass has separated from those next to it.
3. Have your alignment checked every year.
4. Check and correct your tire balance.

1.5 Vehicle load limits

NOTICE Wood-Mizer trailers are not intended to carry any occupants or cargo.

SECTION 2 REPLACEMENT PARTS

2.1 Floor Locations

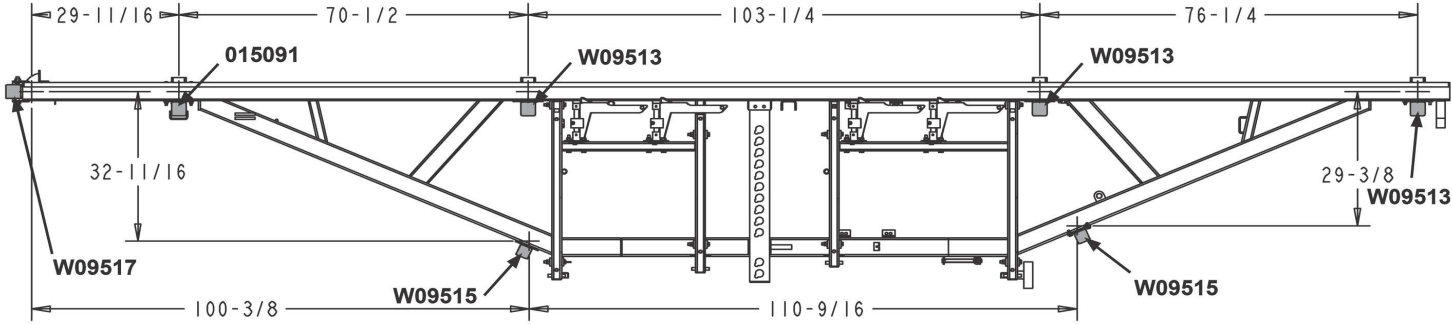

2.2 Overview

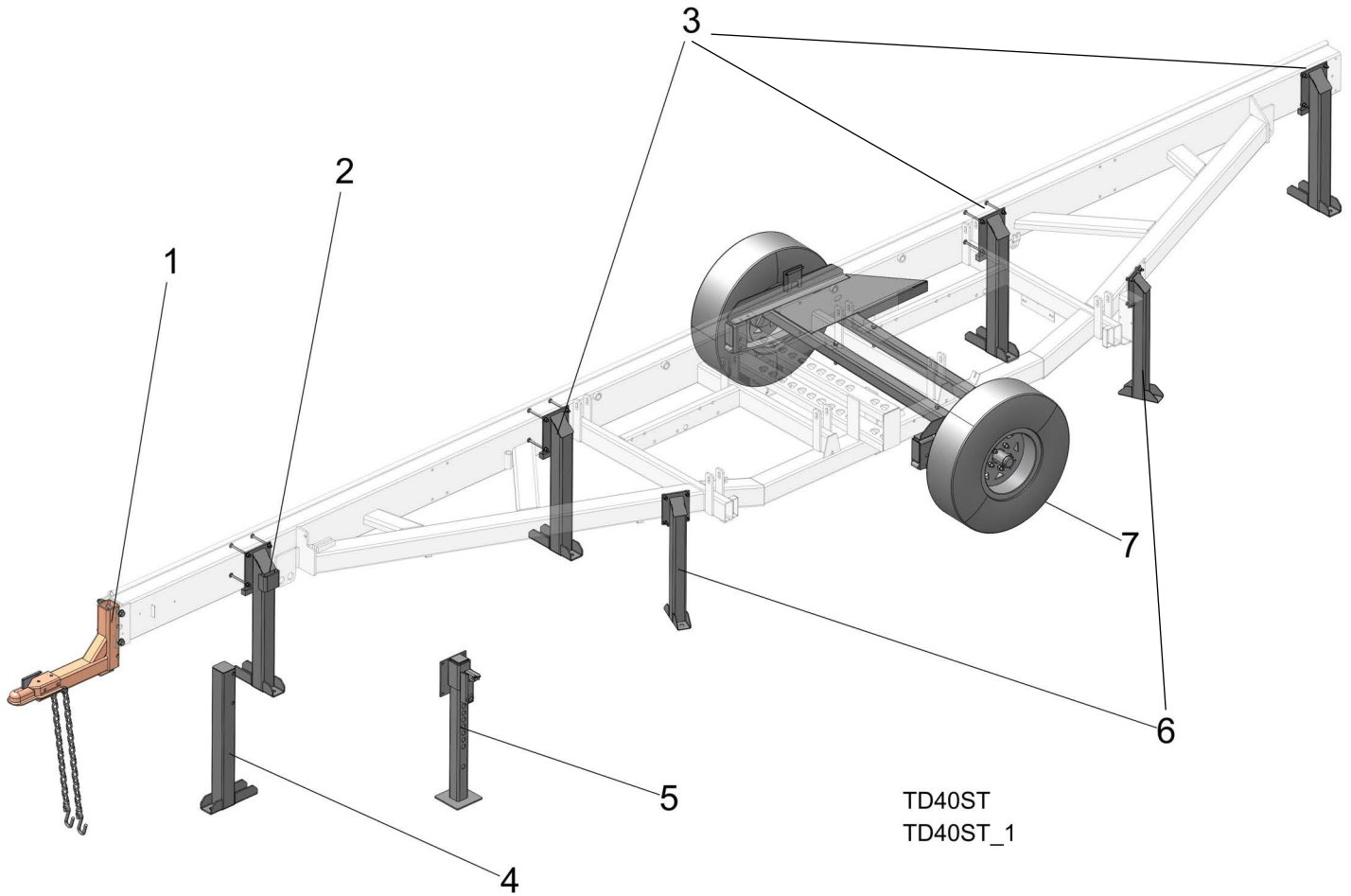

REF	PART #	DESCRIPTION	COMMENTS	QTY.
1	015033	Hitch, Standard Trailer	(See Section 4.2) Replace part with A12083 at permanent site	2
2	015091	Leg Weldment, Stationary Front	See Section 2.6	1
3	W09513	Leg Weldment, Stationary Right	(See Section 2.7)	3
4	W09517	Stationary Leg Front Painted	See Section 2.6	1
5	W07537	Leg, Painted Outrigger	(See Section 2.4) Replaced with 015091 at permanent site	1
6	W09515	Leg Weldment, Stationary Left	See Section 4.6	2
7		Axle Assembly	See Section 4.7	1
	036363	Harness, 40TRB Wiring	Not shown	1

2.3 Hitch and Electrical Box

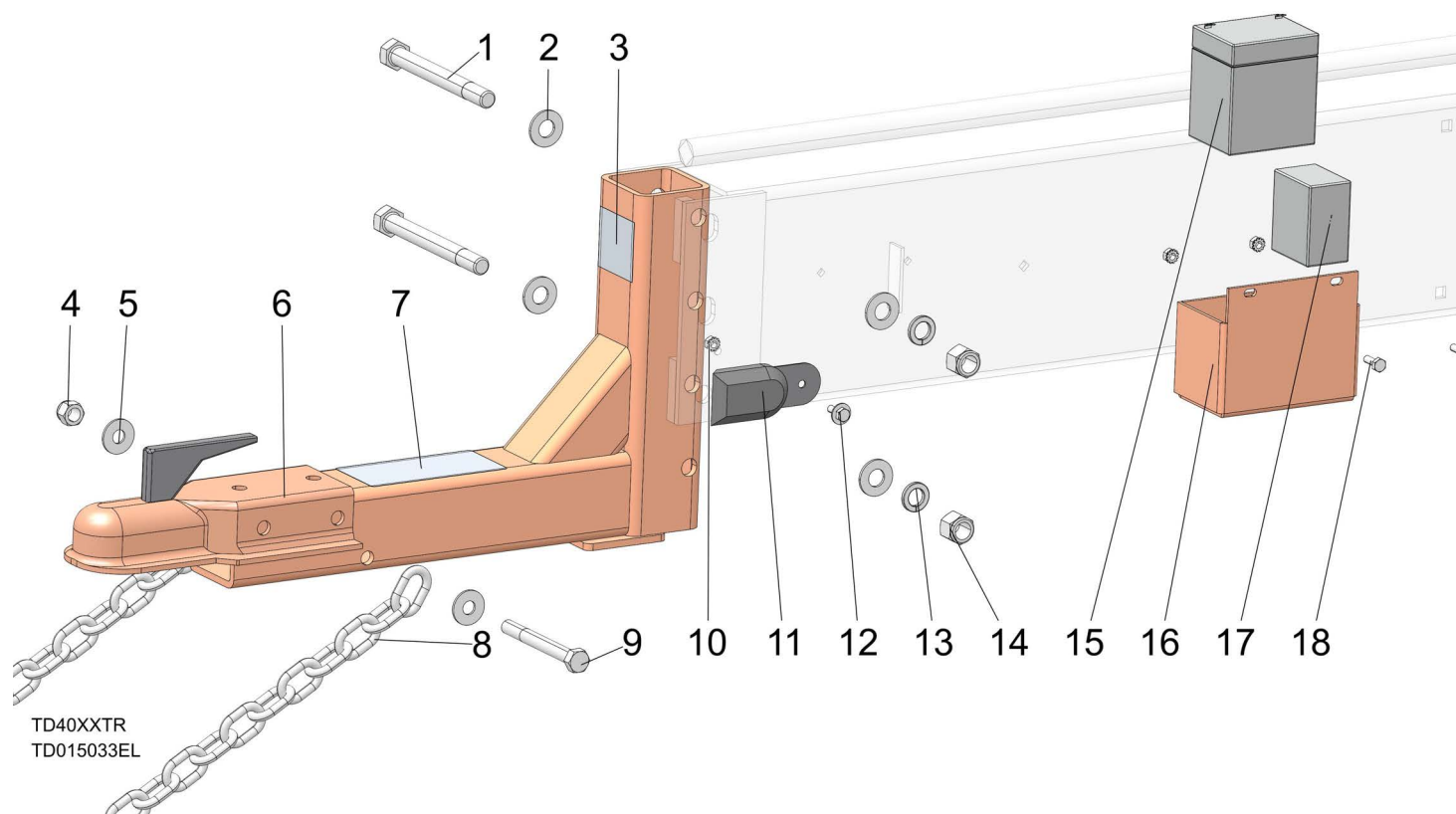

REF	PART #	DESCRIPTION	COMMENTS	QTY.
1	F05009-22	Bolt, 5/8-11x6 Gr5 HH		4
2	F05011-5	Washer, 5/8 SAE Flat		8
3	P11809	Decal, Before Towing Caution		1
4	F05010-8	Nut, 1/2-13 Nyl Hex Lock		3
5	F05011-35	WASHER, 7/16 STANDARD FLAT		4
6	110277	Hitch Wdmt		1
7	014106	Decal, Before Towing Warning		1
8	107163	Chain, 30 Inch Safety		4
9	F05008-35	Bolt, 1/2-13x4 1/2 GR5 Hex Head		1
10	F05010-9	Nut, 1/4-20 Keps	Located inside the frame tube	3
11	014082	Switch, Break Away		1
12	F05005-134	Bolt, 1/4-20x3/4 W/Conical Washer		1
13	F05011-27	Washer, 5/8 Split Zinc Lock		2
14	F05010-34	Nut, 5/8-11 Nyl Lock		4
15	014472	Battery, Break Away	Located inside the frame tube	1
16	015161	Box, Brake Battery	Located inside the frame tube	1
17	014471	Charger, Break-Away Battery	Located inside the frame tube	1
18	F05005-1	Bolt, 1/4-20x3/4 FT HHC		2

2.4 Leg, Transport Only

**THIS LEG IS REPLACED BY
THE 015091 STATIONARY
FRONT LEG AT THE FINAL
DESTINATION**

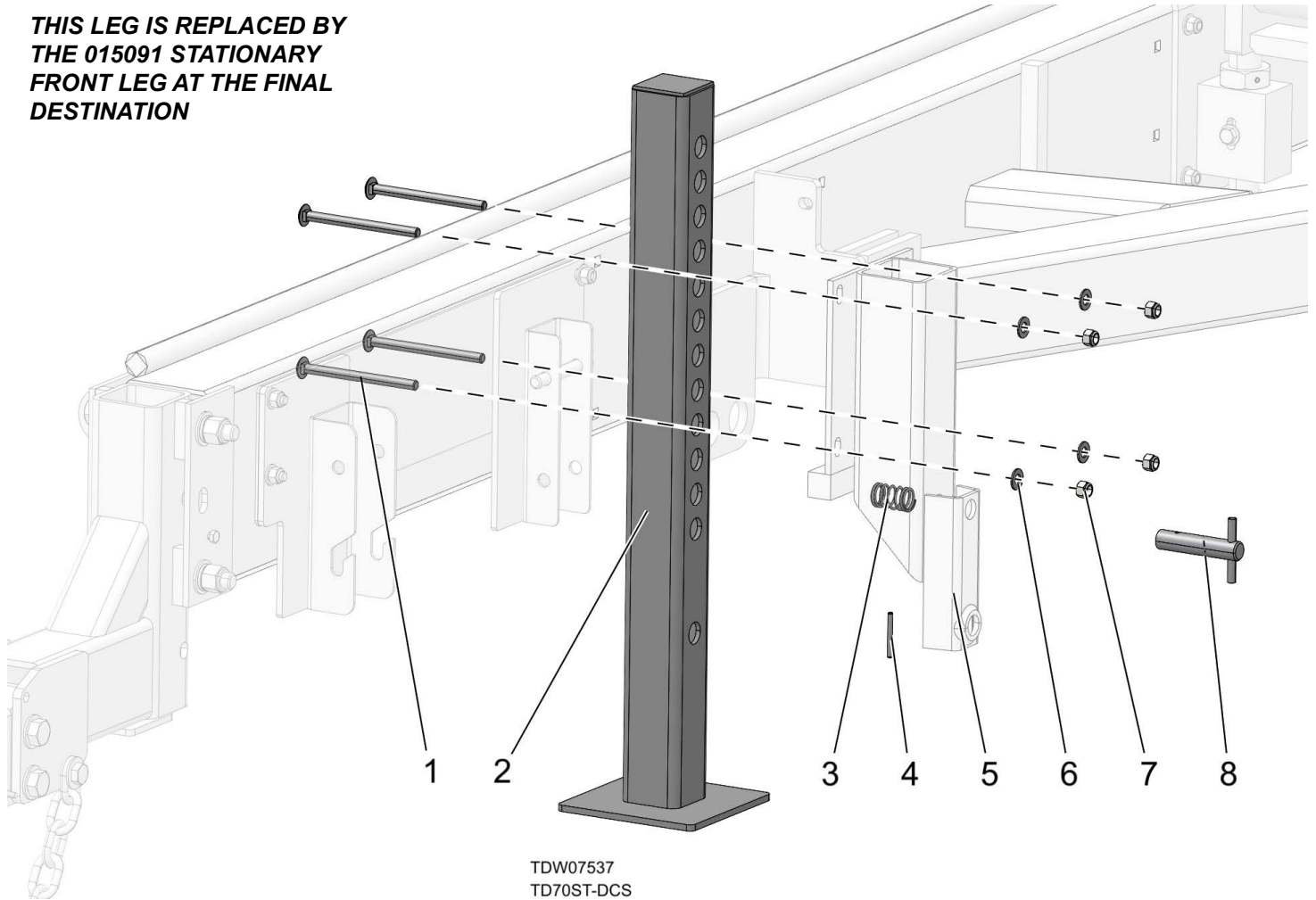

REF	PART #	DESCRIPTION	COMMENTS	QTY.
1	F05007-113	Bolt, 3/8-16x5 Carriage		4
2	W07537	Leg Weldment, Painted Outrigger		1
3	016145	Spring, .92x1.5x.079 Compression		1
4	F05012-103	Pin, 3/16x1 3/4 Roll Zinc		1
5	012996	Guide, Right Outrigger Weldment '96		1
6	F05011-3	Washer, 3/8 Flat SAE		4
7	F05010-10	Nut, 3/8-16 Hex Nyl Lock		4
8	016148	Pin Assembly, .75 Outrigger Pull		1

2.5 Leg, Stationary Front

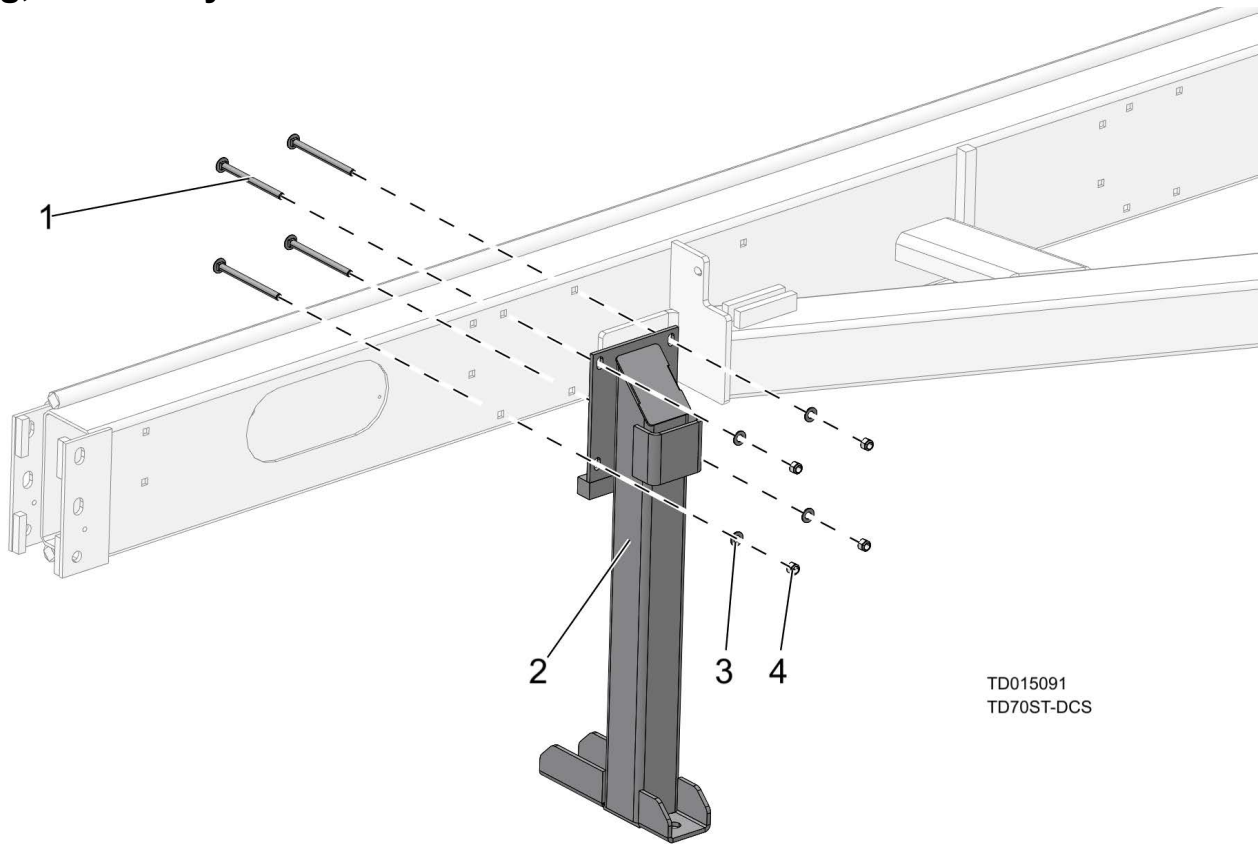

REF	PART #	DESCRIPTION	COMMENTS	QTY.
1	F05007-113	Bolt, 3/8-16x5 Carriage		4
2	015091	Leg Weldment, Stationary Front		1
3	F05011-3	Washer, 3/8 Flat SAE		4
4	F05010-10	Nut, 3/8-16 Hex Nyl Lock		4

2.6 Stationary Leg Front

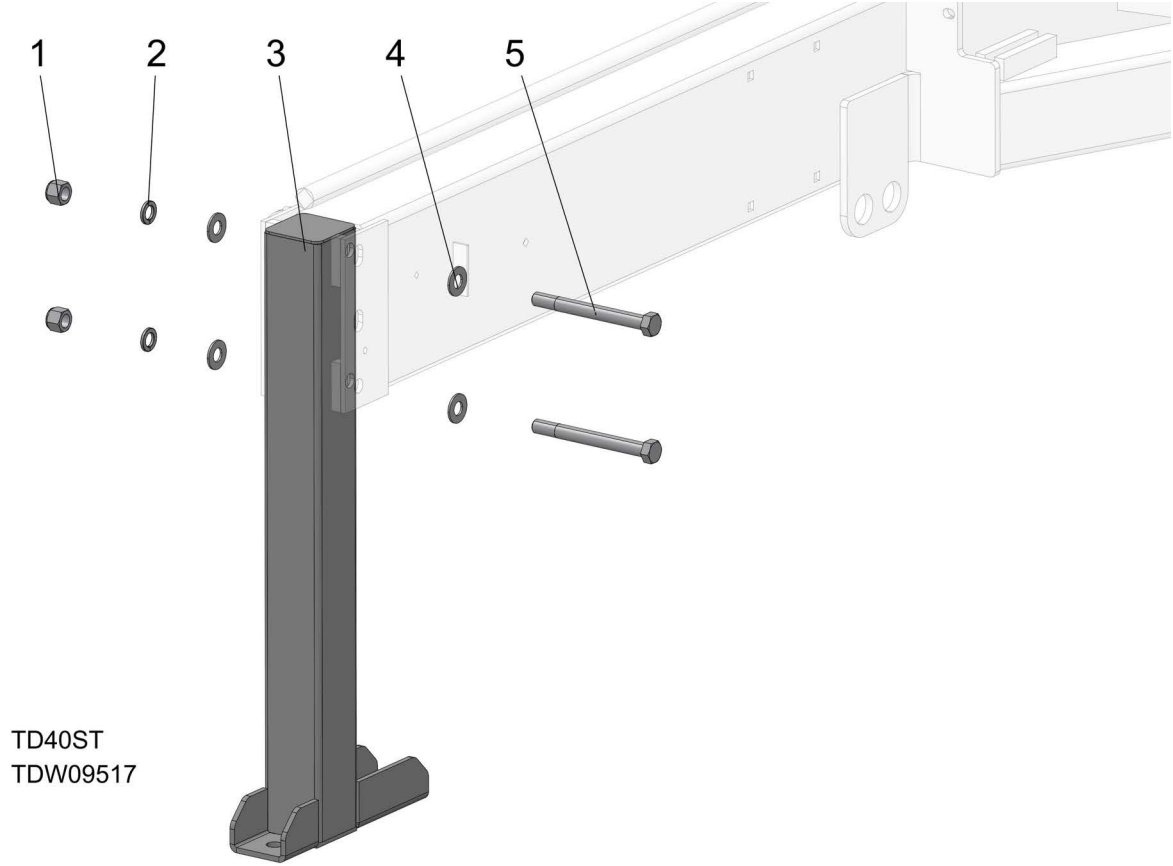

TD40ST
TDW09517

REF	PART #	DESCRIPTION	COMMENTS	QTY.
1	F05010-34	Nut, 5/8-11 Nyl Lock		2
2	F05011-27	Washer, 5/8 Split Zinc Lock		2
3	W09517	Stationary Leg Front Painted		1
4	F05011-5	Washer, 5/8 SAE Flat		4
5	F05009-22	Bolt, 5/8-11x6 Gr5 HH		2

2.7 Leg, Stationary Right

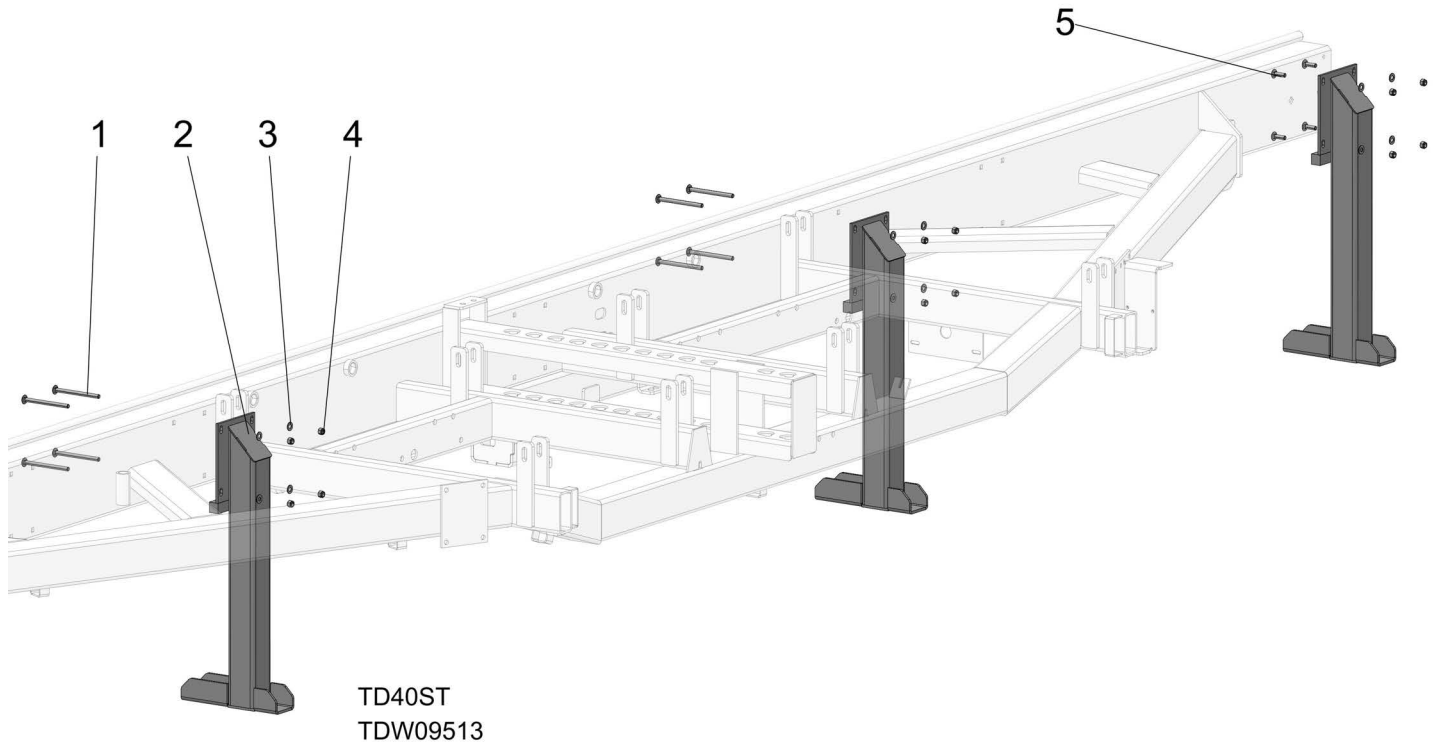

REF	PART #	DESCRIPTION	COMMENTS	QTY.
1	F05007-113	Bolt, 3/8-16x5 Carriage		8
2	W09513	Leg Weldment, Stationary Right Painted		3
3	F05011-3	Washer, 3/8 Flat SAE		12
4	F05010-10	Nut, 3/8-16 Hex Nyl Lock		12
5	F05007-11	Bolt, 3/8-16x1 1/4 Carriage	Located inside the frame tube	4

2.8 Leg, Stationary Left

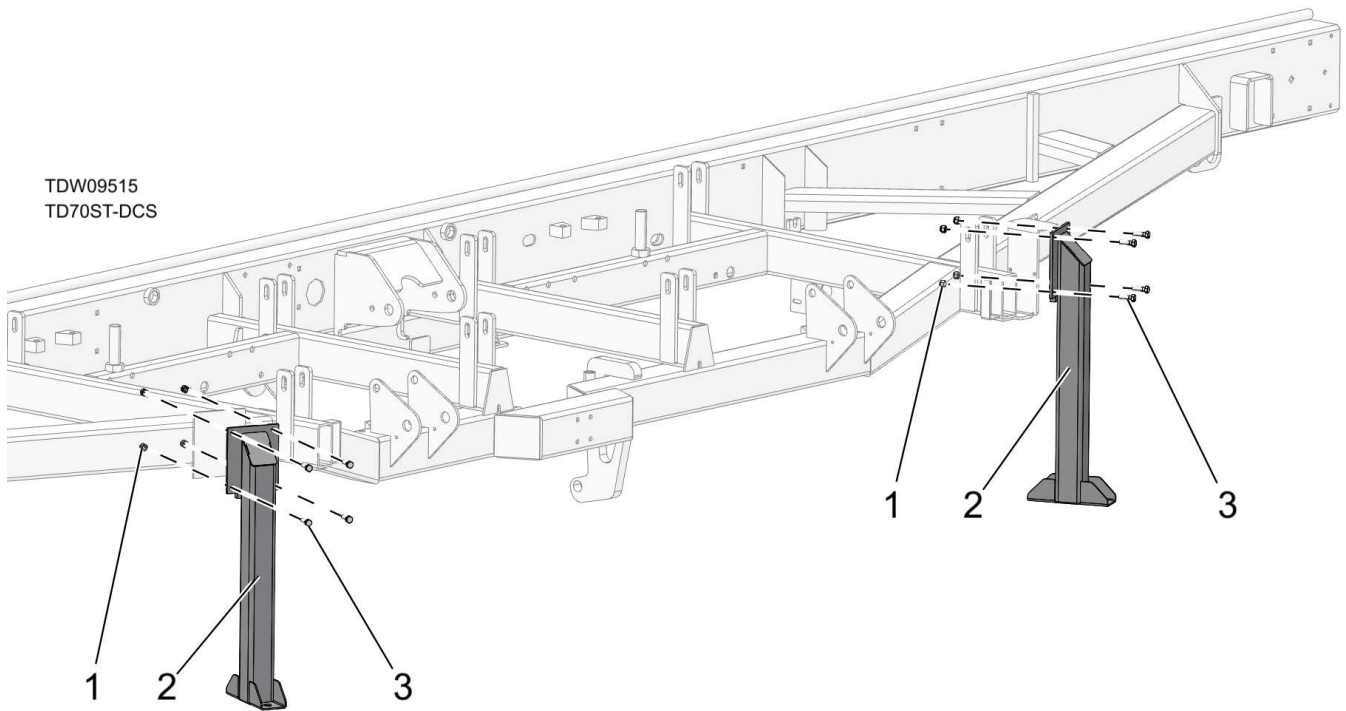

REF	PART #	DESCRIPTION	COMMENTS	QTY.
1	F05010-10	Nut, 3/8-16 Hex Nyl Lock		8
2	W09515	Leg Weldment, Stationary Left Ptd		2
3	F05007-2	Bolt, 3/8-16x1 1/4 HH Gr2		8

2.9 Axle Assembly

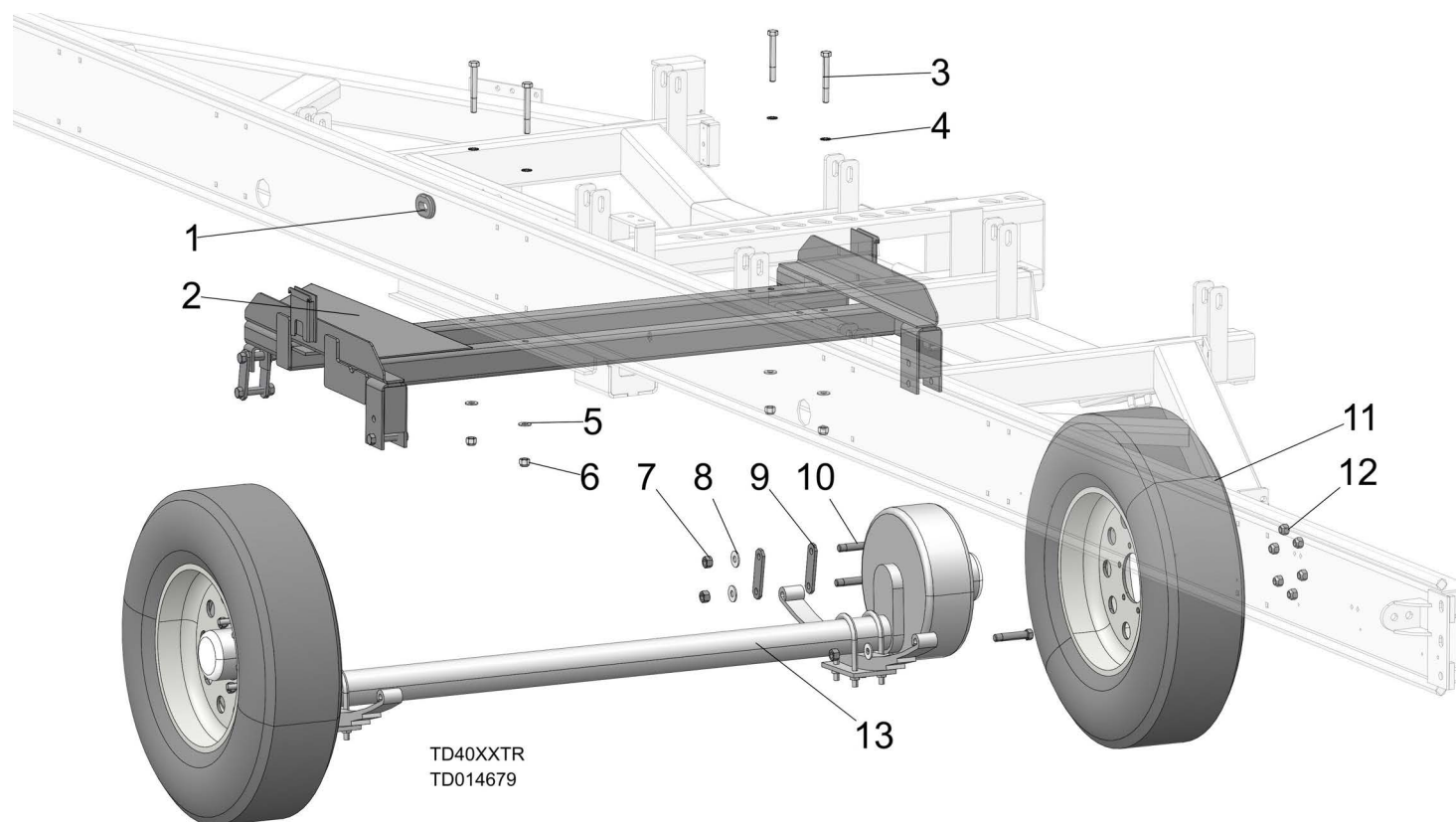

REF	PART #	DESCRIPTION	COMMENTS	QTY.
1	085613	Grommet, Rubber, 1 x 1 3/4 Oval		1
2	015204	Frame Widmt, Axle Super 97		1
3	F05008-26	Bolt, 1/2-13x4 HH Gr2		4
4	F05011-39	Washer, 1/2 Star ET		4
5	F05011-2	Washer, 1/2 SAE Flat		4
6	F05010-8	Nut, 1/2-13 Nyl Hex Lock		4
7	P04643	Nut, 9/16-18 Lock		6
8	F05011-52	WASHER, 9/16 FLAT ZINC		6
9	M07528	Plate, Axle Shackle Link		4
10	P04644	Bolt, 9/16-18x3 Axle Shackle		6
11	133512	Tire Wheel Assy, ST225/75R15 Tamarack		2
12	P04646	Nut, 1/2-20 Lug		12
13	014679	Axle, 5200Lb Drop Super Surge Brake		1
	015695	Spring, 2600 Lb. Dexter Leaf Drive Side	Service Parts	1
	015694	Spring, 3000 Lb. Dexter Leaf Idle Side		1
	015701	Seal, Wheel Bearing Dust Dexter #10-1		1
	015702	Cap, Wheel Bearing Dust		2
	010180	Shoe/Lining Kit, 10" x 2 1/4" Brake		2

2.10 Trailer Lights (2008 to Current)

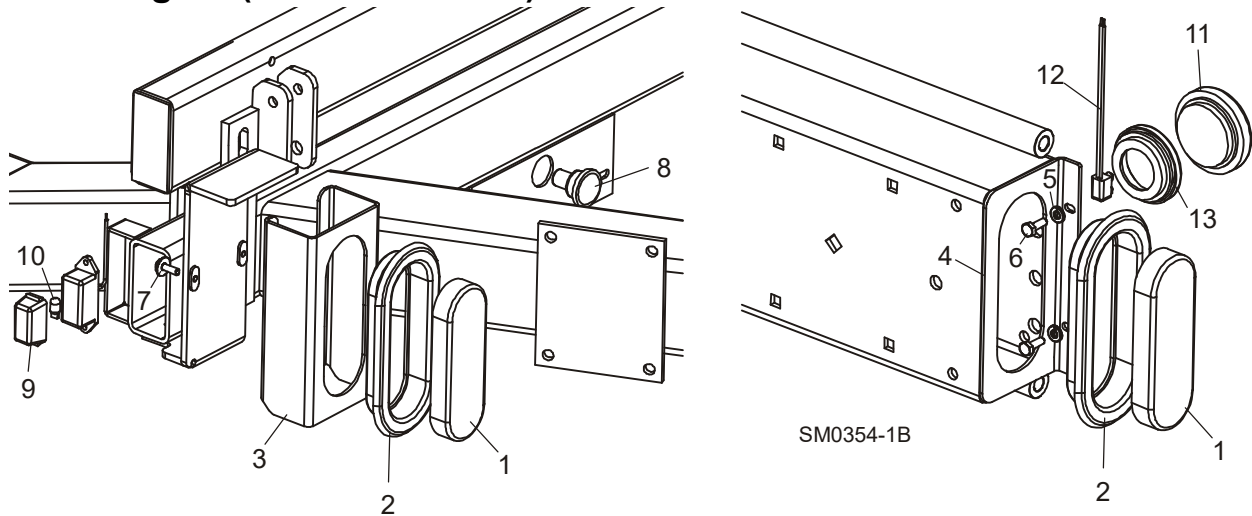

REF	PART #	DESCRIPTION	COMMENTS	QTY.
	P11569	PLUG, 7-PIN ELECTRIC BRAKE TRAILER LIGHT MALE	(NOT SHOWN)	1
	P11755	PLUG, 7-PIN ELECTRIC BRAKE TRAILER LIGHT FEMALE	(NOT SHOWN)	1
1	006391	LIGHT ASSEMBLY, TRAILER TAIL LED		2
2	006688	GROMMET, 6 1/2" LIGHT MOUNTING		2
3	006600	GUARD, IDLE-SIDE TAIL LIGHT		1
4	057822	PLATE, BED TUBE END W/LIGHT MOUNT		1
5	F05011-14	WASHER, 1/4" SPLIT LOCK		2
6	F05005-1	BOLT, 1/4-20 X 3/4" HEX HEAD FULL THREAD		2
7	F05005-134	BOLT, 1/4-20 X 3/4" HEX W/CONICAL WASHER HEAD		2
8	P09928	LIGHT, LICENSE PLATE		1
	P12905	LIGHT, RECTANGLE RED RUNNING		1
	P12906	LIGHT, RECTANGLE AMBER RUNNING	(NOT SHOWN)	1
9	P12921	Lens, Rectangle Red Running Light		1
	P12922	Lens, Rectangle Amber Running Light		1
10	P12923	Bulb, Rectangle Running Light Replacement	Available in assemblies only.	1
	P12913	LIGHT, ROUND RED RUNNING		1
	P12914	LIGHT, ROUND AMBER RUNNING	(NOT SHOWN)	1
11	P12917	Light, Round Red Running Replacement		1
	P12918	Light, Round Amber Running Replacement		1
12	P12920	Pigtail, Round Running Light Replacement		1
13	P12919	Grommet, Round Running Light Replacement		1

2.11 Trailer Lights (Prior to 2007)

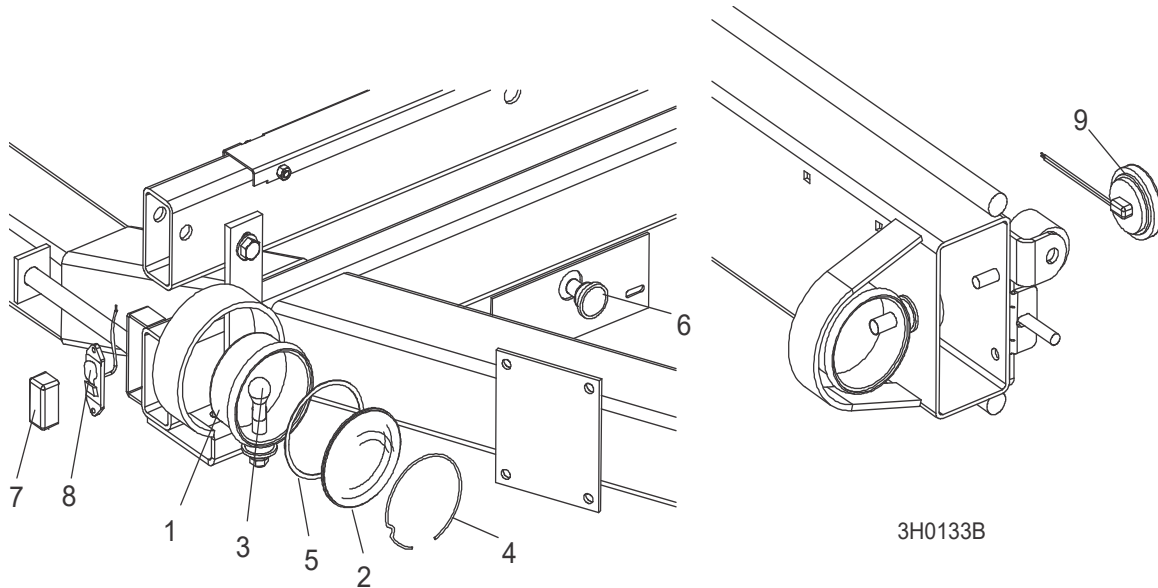

REF	PART #	DESCRIPTION	COMMENTS	QTY.
	014080			1
	014078	PLUG, 6-PIN ELECTRIC BRAKE TRAILER LIGHT FEMALE (NOT SHOWN)		1
1	P04294	LIGHT ASSEMBLY, TRAILER TAIL		2
2	P12509	Lens, Grote Tail Light #90012		1
3	P04481	Bulb, #1157 Trailer Light		1
4	P12510	Clip, Grote Tail Light Retainer		1
5	P12511	Gasket, Grote Tail Light Lens		1
6	P09928	LIGHT, LICENSE PLATE		1
	P12905	LIGHT, RECTANGLE RED RUNNING		1
	P12906	LIGHT, RECTANGLE AMBER RUNNING (NOT SHOWN)		1
7	P12921	Lens, Rectangle Red Running Light		1
	P12922	Lens, Rectangle Amber Running Light		1
8	P12923	Bulb, Rectangle Running Light Replacement	Available in assemblies only. Running light bulb P12923 no longer offered. Bulb is readily available at most local auto parts stores.	1
9	P12913	LIGHT, ROUND RED RUNNING		1
	P12914	LIGHT, ROUND AMBER RUNNING (NOT SHOWN)		1
	P12917	Light, Round Red Running Replacement		1
	P12918	Light, Round Amber Running Replacement		1
	P12920	Pigtail, Round Running Light Replacement		1
	P12919	Grommet, Round Running Light Replacement		1

SECTION 3 ELECTRICAL INFORMATION

3.1 Electric Brake Wiring Diagram (2008-Present)

LT40HD SuperRev. K2.00+
 LT50HD Rev. A3.00+
 LT70HD Rev. B1.00+
 LT70HD SuperRev. A1.00+

Electric brake trailer system diagram for sawmills equipped with LED taillights. (Changed per ECN 17564, 9/8/2008).

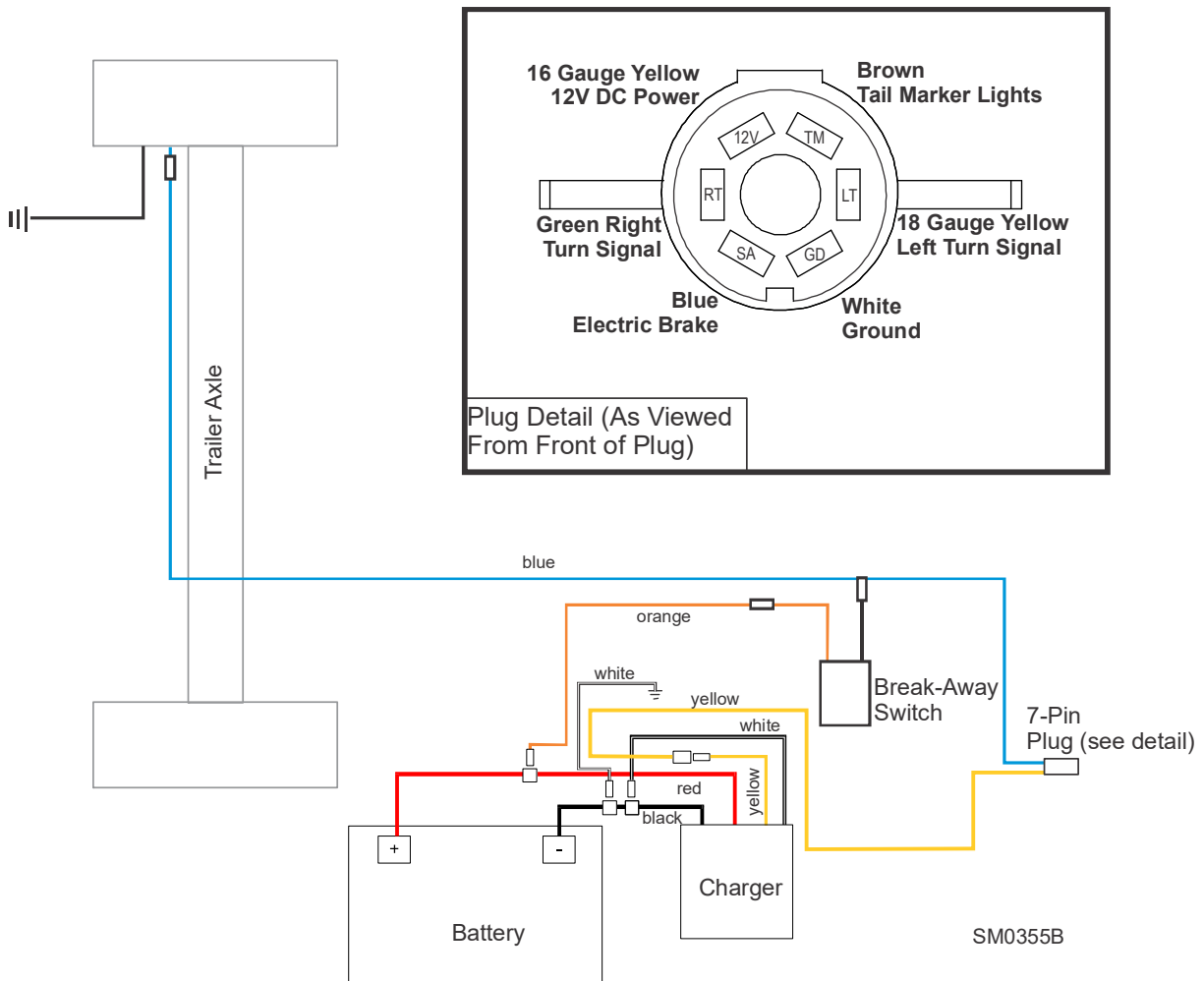

3.2 Wiring Diagram (1997-2008)

LT30 Super Rev. F7.00+
 LT40 Super Rev. F8.00 - J5.03
 LT30HD Rev. G1.00 - K1.03
 LT40HD Rev. G1.00 - K3.01

An electric brake trailer system diagram for sawmills equipped with incandescent taillights is provided below. (Started with ECN 5249, 3/10/1997. Changed per ECN 17564, 9/8/2008).

