

**LT15W Trailer
Safety, Operation,
Maintenance, & Parts Manual**

LT15TRG2W

rev. A1.04

Safety is our #1 concern!

March 2020

Form #2432



WARNING! Read and understand this manual before using this machine.

California
Proposition 65 Warning



WARNING: Breathing gas/diesel engine exhaust exposes you to chemicals known to the State of California to cause cancer and birth defects or other reproductive harm.

Always start and operate the engine in a well-ventilated area.
If in an enclosed area, vent the exhaust to the outside.
Do not modify or tamper with the exhaust system.
Do not idle the engine except as necessary.

For more information go to **www.P65warnings.ca.gov**.



WARNING: Drilling, sawing, sanding or machining wood products can expose you to wood dust, a substance known to the State of California to cause cancer. Avoid inhaling wood dust or use a dust mask or other safeguards for personal protection.

For more information go to **www.P65Warnings.ca.gov/wood**.

Active Patents assigned to Wood-Mizer, LLC

Wood-Mizer, LLC has received patents that protect our inventions which are a result of a dedication to research, innovation, development, and design. Learn more at: woodmizer.com/patents

©2024 Wood-Mizer LLC

Printed in the United States of America, all rights reserved. No part of this manual may be reproduced in any form by any photographic, electronic, mechanical or other means or used in any information storage and retrieval system without written permission from

Wood-Mizer, LLC
8180 West 10th Street
Indianapolis, Indiana 46214

SECTION 1 TIRE SAFETY

1.1 Tire labeling.....1-1
1.2 Recommended tire inflation pressure1-1
1.3 Glossary.....1-3
1.4 Tire care, maintenance, and safety practices1-4
1.5 Vehicle load limits.....1-4

SECTION 2 TRAILER ASSEMBLY

2.1 Safety Symbols.....2-1
2.2 Safety Instructions2-1
2.3 Required Tools2-2
2.4 Uncrating the Trailer2-2
2.5 Trailer Parts List.....2-2
2.6 Installation2-4
2.7 Tongue Frame & Rear Light Bar Installation.....2-7
2.8 Final Installation.....2-10

SECTION 3 TRAILER OPERATION

3.1 Prepare For Travel.....3-1
3.2 Prepar For Operation3-2
3.3 Loading, Turning, And Clamping Logs3-3

SECTION 4 MAINTENANCE

SECTION 5 REPLACEMENT PARTS

5.1 Trailer (Complete)5-1
5.2 Tongue Assembly5-2
5.3 Front and Rear Jack Assemblies.....5-4
5.4 Trailer Brace Assembly5-5
5.5 Center Jack Assembly5-6
5.6 Trailer Axle Assembly5-7
5.7 Head Rest Assembly5-8
5.8 Crank Handle and Adjustable Jack Assembly5-9
5.9 Rear Light Bar5-10
5.10 Wiring Harness5-11

SECTION 1 TIRE SAFETY

1.1 Tire labeling

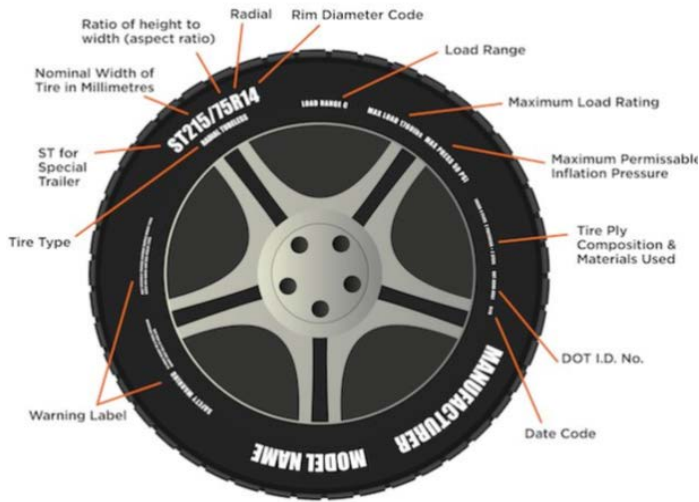

Tire markings

TIRE CLASS AND SIZE: (Example: ST215/75R14)

- **ST** stands for Special Trailer tire. ST trailer tires are built to tow heavy loads, withstand excessive heat, and reduce sway.
- **215** is tire width in millimeters;
- **75** is the aspect ratio, or ratio of height to width;
- **R** is type of construction (radial, in the example)
- **14** is rim diameter in inches.

TIRE TYPE Below the tire size is either 'radial' or 'bias.' Radial tires (or 'radial-ply tires') are constructed with polyester and/or nylon plies that run across the tire perpendicularly, and sometimes include steel belts that run under the tread. Bias-ply tires Bias-ply cords layer in a criss-cross pattern from sidewall to sidewall, and they are also sometimes reinforced with a steel belt.

LOAD RANGE Load range indicates the type of load a tire is designed to support at a specific inflation pressure. Trailer tires typically have C, D, or E load ranges. A load range 'C' tire, for example, is at its peak load capacity—possibly 1600 pounds—when it's inflated to its maximum pressure of 50 PSI. A load range 'C' tire at 25 PSI might be able to support a load of 990 pounds, while at 40 PSI, that capacity could be 1300 pounds.

MAXIMUM LOAD RATING Load rating or load index indicates the weight a tire can safely carry at its maximum air pressure. In the example, at its maximum air pressure of 50 PSI (cold), a load range 'C' tire might have a load rating of 1760 pounds.

MAXIMUM PRESSURE Maximum pressure (when the tires are cold) needed for the tires to carry the maximum load; measured in PSI.

Identifying tires

Tires are required to have a Tire Identification Number (TIN) begin with the letters "DOT," followed by eight to thir-

teen characters that can be used to identify the manufacturing location, tire size, and manufacturer's specifications, along with the week and year the tire was manufactured. DOT Tire Identification Numbers are commonly but erroneously referred to as the tire's serial number, but it actually identifies production *batches*, not individual items.

Regulations also require the entire DOT Tire Identification Number to be branded on one sidewall, while only the letters "DOT" and the first digits of the Tire Identification Number must be branded onto the opposite sidewall. Therefore it is possible to see a Tire Identification Number that appears incomplete, yet simply requires looking at the tire's other sidewall to find the complete Tire Identification Number.

Tire Identification Number

DOT AND DATE CODES Department of Transportation identifier will include 10-12 numbers following 'DOT.' The first six to eight numbers indicate the manufacturer's code, where the tire was manufactured and the tire size.

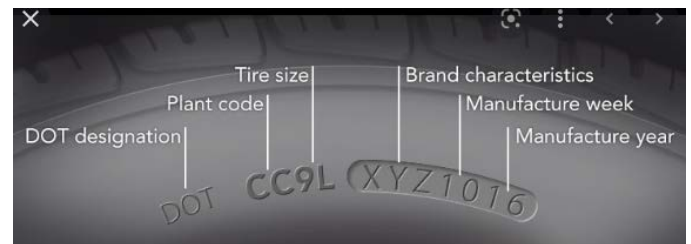

1.2 Recommended tire inflation pressure

Recommended cold tire inflation pressure

The cold inflation pressure is the contained air pressure of a tire that would occur at an indexed temperature of 68°F or 20°C. This indexed temperature is based on the ideal ambient operating conditions for the tire.

Ambient air temperature pressure adjustment tables:

TABLE 1-1 - IMPERIAL MEASUREMENTS

Listed Pressure	10 psi	20 psi	30 psi	40 psi	50 psi	60 psi	70 psi	80 psi	90 psi	100 psi
104°	11.7	22.4	33.1	43.7	54.4	65.1	75.8	86.5	97.1	107.8
86°	10.8	21.2	31.5	41.9	52.2	62.5	72.9	83.2	93.6	103.9
68°	10.0	20.0	30.0	40.0	50.0	60.0	70.0	80.0	90.0	100.0
50°	9.2	18.8	28.5	38.1	47.8	57.5	67.1	76.8	86.4	96.1
32°	8.3	17.6	26.9	36.3	45.6	54.9	64.2	73.5	82.9	92.2
14°	7.5	16.4	25.4	34.4	43.4	52.4	61.3	70.3	79.3	88.3
-4°	6.6	15.3	23.9	32.5	41.2	49.8	58.4	67.1	75.7	84.3
-22°	5.8	14.1	22.4	30.7	39.0	47.3	55.5	63.8	72.1	80.4
-40°	4.9	12.9	20.8	28.8	36.8	44.7	52.7	60.6	68.6	76.5

METRIC MEASUREMENTS

Listed Pressure	69 kPa	138 kPa	207 kPa	276 kPa	345 kPa	414 kPa	483 kPa	551 kPa	620 kPa	689 kPa
40°	81	154	228	301	375	449	522	596	670	743
30°	75	146	217	289	360	431	502	574	645	716
20°	69	138	207	276	345	414	483	551	620	689
10°	63	130	196	263	329	396	463	529	596	662
0°	57	122	186	250	314	378	443	507	571	635
-10°	52	113	175	237	299	361	423	485	546	608
-20°	46	105	165	224	284	343	403	462	522	581
-30°	40	97	154	211	269	326	383	440	497	554
-40°	34	89	144	199	253	308	363	418	473	527

The vehicle tire inflation pressure label and location

The generic bilingual tire pressure label appears as in FIG. 1-3. The label on the vehicle has information specific to the trailer filled in

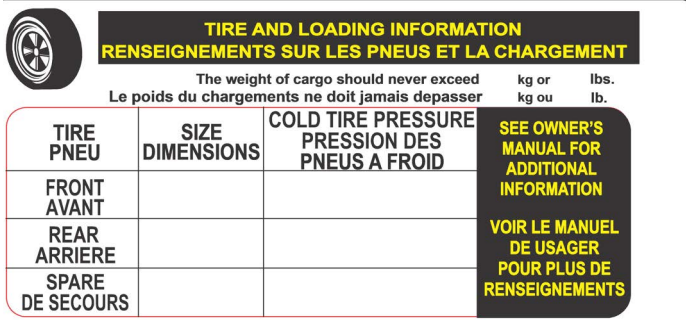

The label is placed near the VIN placard, toward the **front left side** of the trailer.

General area of VIN placard and tire pressure label for Wood-Mizer mill trailers.

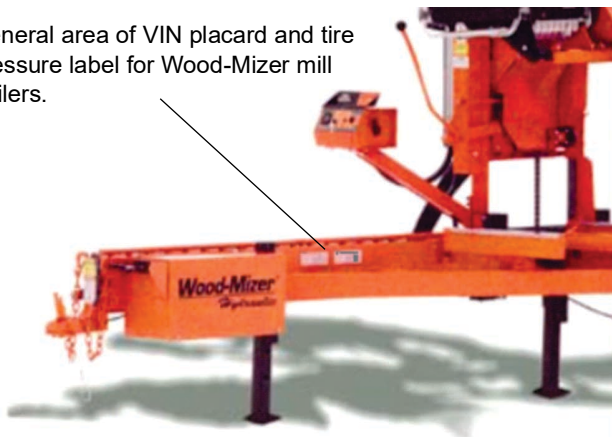

Consequences of tire under-inflation

Underinflated tires and overloaded vehicles are a major cause of tire failure. Tire inflation effects a vehicle's

- steering,
- stopping,

- traction, and
- load-carrying capability.

To avoid flat tires and other types of tire failure, you should

- maintain proper tire pressure,
- observe tire and vehicle load limits,
- avoid road hazards, and
- regularly inspect your tires.

Proper inflation

CHECK TIRE PRESSURE

Use a tire pressure gauge, which you can be purchased at most service stations or auto parts stores. Check the pressure when the tires are **COLD**, as the friction from driving affects the pressure. If driven recently, wait at least three hours for the tires to cool down.



COMMON TIRE PRESSURE GAUGES

1. Remove the cap from the air valve on the tire, and put it somewhere you won't lose it.
2. Press the tire gauge against the open valve stem momentarily.
3. Read the air pressure gauge.
4. Compare this number with the recommended tire pressure.
5. Inflate/release air as needed.
6. Replace the tire's air valve cap.
7. Repeat this process for each tire.

INFLATE YOUR TRAILER'S TIRES

1. Park close enough to the air compressor so you can reach all tires with the hose.
2. If the valve caps are still on, remove them.
3. Press the hose nozzle down on the valve stem.

NOTE: You should notice the tire inflating and feel air flowing through the hose. If not, check to ensure

FIG. 1-4 the hose is securely placed on the valve stem.

4. Remove the hose fitting.
5. Check the air pressure as described above.
6. Repeat steps 3- 5 as needed until the tire is inflated to the correct psi.
7. Repeats steps 2-5 for the vehicle's other tires.

8. Once the tires are inflated properly, replace the valve caps.

RELEASE AIR FROM TIRES

Overinflated tires can lead to poor handling, such as skidding and hydroplaning.

1. Briefly press the small dot or bead on the back of the tire pressure gauge into the center of the valve stem on the tire.

NOTE: You should hear the air escaping the tire.

2. Use the gauge to check the tire pressure.
3. Repeat these steps until you've released enough air to reach the correct psi.

WHEN TO CHECK TIRE PRESSURE

Use Table 1-1 to adjust the recommended cold tire pressure to the ambient temperature. Check tire pressure monthly.

- Most tires may naturally lose air over time.
- Tires can lose air suddenly if you drive over a pothole or other object or if you strike the curb when parking.
- With radial tires, it is usually not possible to determine underinflation by visual inspection.

1.3 Glossary

ALPHA CHARACTER A single alphabetical character from A to Z.

BEAD SEPARATION A breakdown of bond between components in the bead area.

BEAD That part of the tire made of steel wires, wrapped or reinforced by ply cords, that is shaped to fit the rim.

CARCASS PLY A ply that extends to the beads.

CARCASS The tire structure, except tread and sidewall rubber.

CHUNKING The breaking away of pieces of the tread or sidewall.

COLD TIRE PRESSURE The air pressure in a tire at ambient temperature, **not having been driven for the at least 3 hours**.

CORD SEPARATION Cord parting away from adjacent rubber compounds.

CORD The strands that form the plies in the tire.

CRACKING Any parting within the tread, sidewall, or innerliner of the tire extending to cord material.

CURB WEIGHT The weight of a motor vehicle with standard equipment including the maximum capacity of fuel, oil, and coolant, and, if so equipped, air conditioning and additional weight of optional engine.

DEEP TREAD RADIAL A deep tread radial tire is one having a minimum tread depth of 14.3 mm (18/32 inch or 0.5625 inch) or greater.

DOT SYMBOL The letters "DOT" are part of the DOT serial number. This is the manufacturer's certification that the tire or rim meets or exceeds the requirements of FMVSS Nos. 110 and 139.

DOT TIRE IDENTIFICATION NUMBER Number appearing on the sidewall of the tire near the rim required by 49 CFR Part 574.5 which identifies the manufacturer's identification mark, tire size, tire type code and date of manufacture. See Fig. 1-2.

EXTRA LOAD TIRE A tire designed to operate at higher loads and at higher inflation pressures than the corresponding standard tire.

FIELDS Any group of letters and numbers that have significance or meaning.

GAWR The Gross Axle Weight Rating (GAWR) means the value specified by the vehicle manufacturer as the load-carrying capacity of a single axle system, as measured at the tire-ground interfaces.

GROOVE The space between two adjacent tread ribs.

GVWR The Gross Vehicle Weight Rating (GVWR) means the value specified by the manufacturer as the loaded weight of a single vehicle.

INNERLINER SEPARATION The parting of the innerliner from cord material in the carcass.

INNERLINER The layer(s) forming the inside surface of a tubeless tire that contains the inflating medium within the tire.

INTENDED OUTBOARD SIDEWALL (1) The sidewall that contains a whitewall, bears white lettering or bears manufacturer, brand, and/or model name molding that is higher or deeper than the same molding on the other sidewall of the tire; or (2) The outward facing sidewall of an asymmetrical tire having a particular side that must always face outward when mounted on a vehicle.

LIGHT VEHICLE TIRE A new, pneumatic, radial tire intended for use on motor vehicles (other than motorcycles and low speed vehicles) that have a gross vehicle weight rating (GVWR) of 10,000 pounds or less and were manufactured after 1975.

LOAD RATING The maximum load a tire is rated to carry for a given inflation pressure.

MAXIMUM LOAD RATING The load rating at the maximum permissible inflation pressure for that tire.

MAXIMUM INFLATION PRESSURE The maximum cold inflation pressure needed for your tire to support the weight of its **maximum load-carrying capacity**.

MEASURING RIM The rim on which a tire is fitted for physical dimension requirements.

NHTSA/OVSC National Highway Traffic Safety Administration, Office of Vehicle Safety Compliance (Canada).

OPEN SPLICE Any parting at any junction of tread, sidewalls, or innerliner that extends to cord material.

OUTER DIAMETER The overall diameter of an inflated new tire.

OVERALL WIDTH The linear distance between the exteriors of the sidewalls of an inflated tire, including elevations due to marking, decorations, or protective bands or ribs.

PLY A layer of rubber-coated parallel cords.

PLY SEPARATION A parting or rubber compound between adjacent plies.

PNEUMATIC TIRE A mechanical device made of rubber, chemicals, fabric, steel, or other materials, which, when mounted on an automotive wheel, provides the traction and contains the gas or fluid that sustains the load.

RADIAL PLY TIRE A pneumatic tire in which the ply cords that extend to the beads are laid at substantially 90° to the centerline of the tread.

RECOMMENDED INFLATION PRESSURE The cold inflation pressure provided on the Tire Information label and on the VIN tag.

REINFORCED TIRE A tire designed to operate at higher loads and at higher inflation pressures than the corresponding standard tire.

RESPONSIVE TEST A special test initiated through a complaint, field inspection, failed standard test, or COTR discretion. RIM A metal support for a tire or a tire and tube assembly upon which the tire beads are seated.

RIM DIAMETER Nominal diameter of the bead seat.

RIM SIZE DESIGNATION Rim diameter and width.

RIM TYPE DESIGNATION The industry or manufacturer's designation for a rim by style or code. RIM WIDTH Nominal distance between rim flanges.

SECTION WIDTH The linear distance between the exteriors of an inflated tire's sidewalls, excluding elevations due to marking, decoration, or protective bands.

SIDEWALL That portion of a tire between the tread and the bead.

SIDEWALL SEPARATION The parting of the rubber compound from the cord material in the sidewall.

SIZE FACTOR The sum of the section width and the outer diameter of a tire determined on the test rim.

SNOW TIRE A snow tire means a tire that attains a traction index equal to or greater than 110, compared to the ASTM E-1136 Standard Reference Test Tire, when using the snow traction test as described in ASTM F-1805-00, Standard Test Method for Single Wheel Driving Traction in a Straight Line on Snow- and Ice-Covered Surfaces, and which is marked with an Alpine Symbol specified in S5.5(i) of FMVSS No. 139 on at least one sidewall.

TREAD That portion of a tire that comes into contact with the road.

TREAD RIB A tread section running circumferentially around a tire.

TREAD SEPARATION Pulling away of the tread from the tire carcass.

TREADWEAR INDICATORS (TWI) Projections within the principal grooves designed to give a visual indication of the degree of wear of the tread.

UVW The Unloaded Vehicle Weight (UVW) is the weight of a vehicle with maximum capacity of all fluids necessary for vehicle operation, but without cargo, occupants, or accessories that are ordinarily removed from the vehicle when they are not in use.

VEHICLE NORMAL LOAD ON THE TIRE The vehicle normal load on the tire means that load on an individual tire that is determined by distributing to each axle its share of the curb weight, accessory weight, and normal occupant weight and dividing by 2.

1.4 Tire care, maintenance, and safety practices

1. Check your cold tire pressure at least once a month (See [Proper inflation](#))
2. Visually inspect your tires
 - 1). Check the tread at least once a month for excessive or uneven wear.
 - 2). Measure tread depth in three locations across the tire's tread: (1) outer edge, (2) center, and (3) inside edge.

NOTE: Accurate tread depth measurements are made with a simple tread depth gauge available at any parts store.
--Or you can use the quarter (coin) method. Insert a quarter into a tread groove with the top of Washington's head facing down. If the top of his head is not visible, your tires have at least 4/32" of tread and are fine for continued use. If you can see above the top of Washington's head, replace the tire.
 - 3). Inspect for over inflation: wear primarily in the center of the tread, with less wear at the tire's edges.
 - 4). Inspect for under inflation: wear primarily on both edges of the tire tread, with less wear in the center.
 - 5). Inspect for tread wear on one edge of the tire which occurs when the wheels are out of alignment.
 - 6). Inspect for erratic tread wear, "cupping," caused by the wheel out of balance, or suspension components need to be replaced.
 - 7). Inspect for raised portion of the tread or sidewall which may indicate that one of the belts in the tire carcass has separated from those next to it.
3. Have your alignment checked every year.
4. Check and correct your tire balance.

1.5 Vehicle load limits

NOTICE Wood-Mizer trailers are not intended to carry any occupants or cargo.

SECTION 2 TRAILER ASSEMBLY

2.1 Safety Symbols

The following symbols and signal words call your attention to instructions concerning your personal safety. Observe and follow these instructions.



DANGER! indicates an imminently hazardous situation which, if not avoided, will result in serious injury or death.



WARNING! suggests a potentially hazardous situation which, if not avoided, could result in serious injury or death.



CAUTION! refers to potentially hazardous situations which, if not avoided, may result in minor or moderate injury or damage to equipment.

NOTICE indicates vital information.

2.2 Safety Instructions

OWNER/OPERATOR'S RESPONSIBILITY

The procedures listed in this manual may not include all ANSI, OSHA, or locally required safety procedures. **It is the owner/operator's responsibility and not Wood-Mizer LLC to ensure all operators are properly trained and informed of all safety protocols.** Owner/Operators are responsible for following all safety procedures when operating and performing maintenance to the equipment.

Observe ALL Safety Instructions

NOTICE Read the entire Operator's Manual before operating this equipment.

Note all safety warnings throughout this manual and those posted on the equipment.

Be able to access this manual at all times while operating this equipment.

Read additional manufacturer's manuals and observe their applicable safety instructions.

Only persons who have read and understood the entire operator's manual should operate this equipment.

This equipment is not intended for use by or around children.

It is the owner/operator's responsibility to comply with all applicable federal, state, and local laws, rules, and regulations regarding the ownership, operation, and transporting your equipment.

Operators should become thoroughly familiar with and comply with these applicable laws for operating and transporting equipment.

NOTICE! This trailer option is intended for use with LT15W sawmills only.

2.3 Required Tools

- Wrench sizes 3/4 in, 9/16 in, 7/16 in. (Two wrenches or a combination of a wrench and a socket with a ratchet may be required)
- Fish tape (20 ft minimum)
- Sawhead
- Rubber mallet (for uncrating or aligning heavy assemblies)
- Lifting equipment

2.4 Uncrating the Trailer

The LT15 trailer is bolted to the shipping crate with lag screws and shipping brackets as shown in Fig. 1-1. Unbolt these sections for assembly. Smaller assemblies are shipped in the boxes.

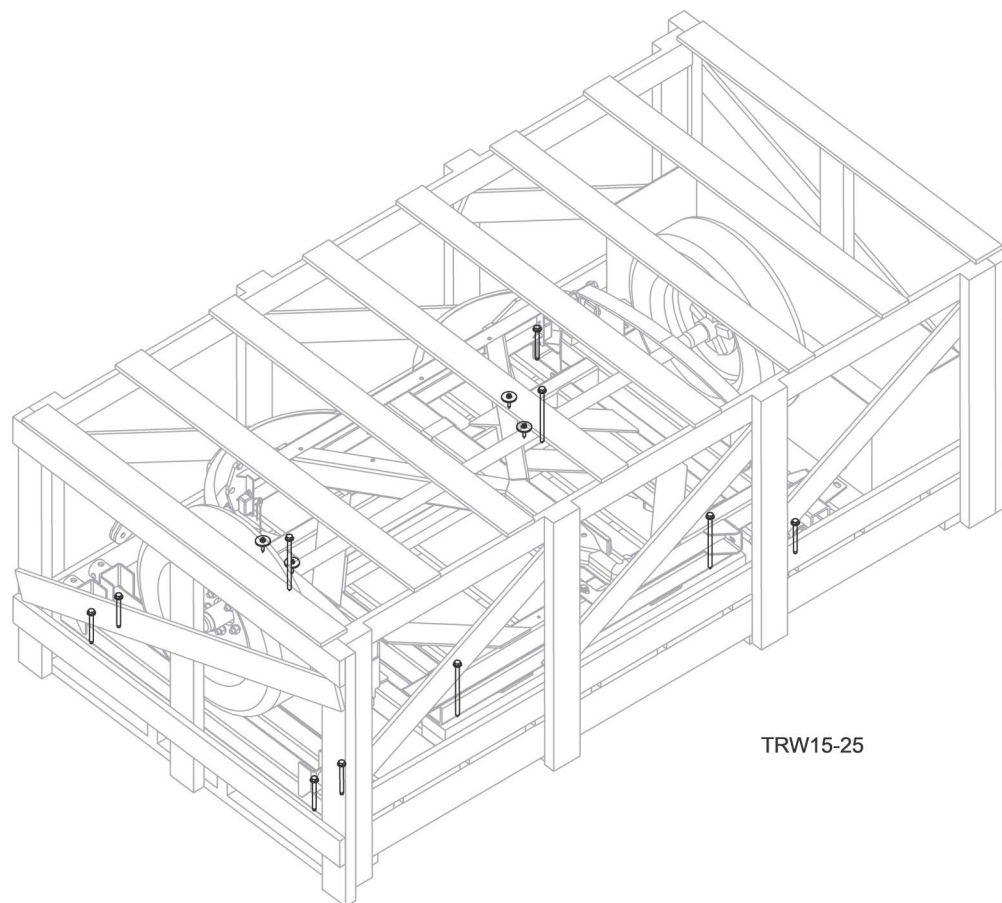
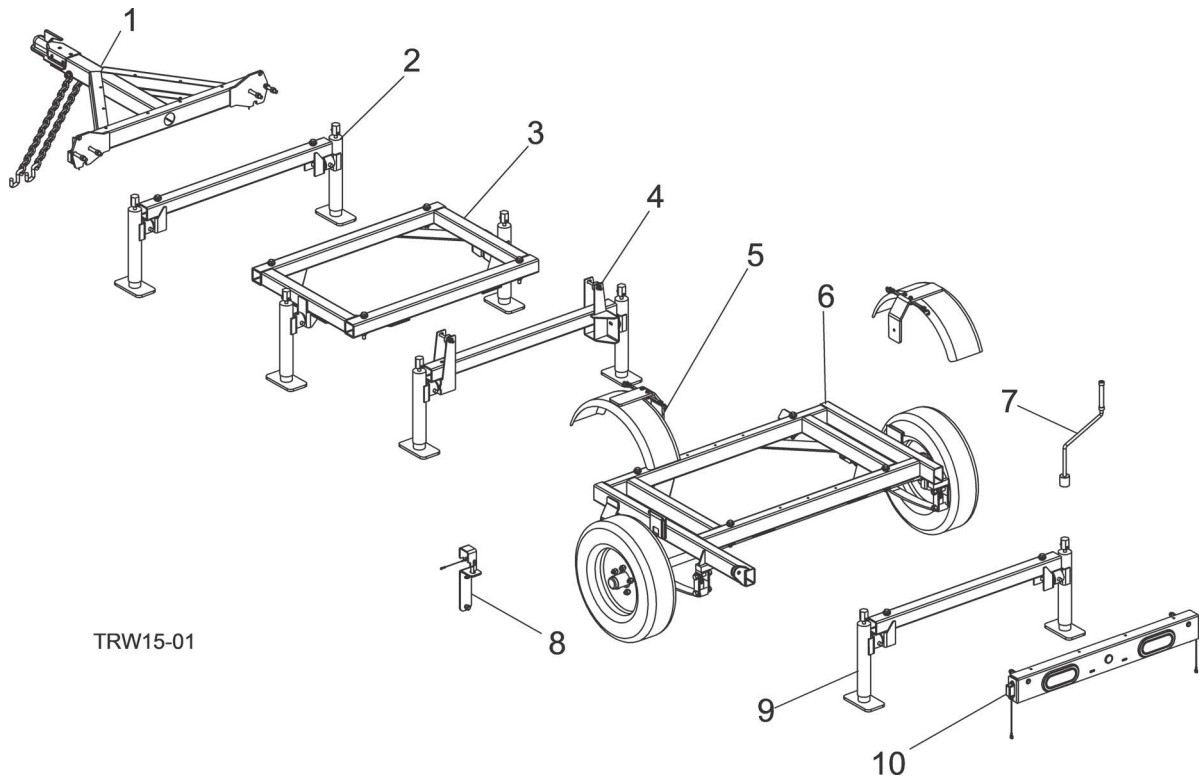

FIG. 2-1

2.5 Trailer Parts List

Lay the parts out in a general configuration as when installed.

NOTE: See the replacement parts section for a full list of components, part numbers, and installation location.



TRW15-01

FIG. 2-2

- | | |
|------------------------------|------------------------------|
| 1. Tongue | 6. Axle |
| 2. Front Jack (same as rear) | 7. Jack Crank Handle |
| 3. Brace Weldment | 8. Head Rest |
| 4. Center Jack | 9. Rear Jack (same as front) |
| 5. Fenders | 10. Rear Light Bar |

BOLTS (SIZE NOT TO SCALE):

(2) 3/8-16 x 5" Carriage



(1) 1/2-13 x 1 1/2" Hex Head

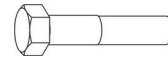

(1) 1/4-20 x 2 3/4" Hex Head

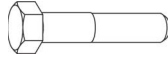

(1) 1/2-13 x 3 1/2" Hex Head Full Thread Tap



(1) 3/8-16 x 3/4" Hex Head



(12) 1/2-13 x 4 1/2" Hex Head



Bed to jack frames

(2) 3/8-16 x 3 3/4" Hex Head

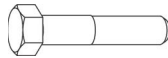

(3) 1/2-13 x 3 1/2" Hex Head



Bed to axle frames

NUTS (SIZE NOT TO SCALE):

(1) 1/2-13 Swaged Hex



(1) 3/8-16 Keps



(16) 1/2-13 Hex Nylon Lock



(4) 3/8-16 Hex Nylon Lock



(1) 1/2-13 Free Hex



WASHERS (SIZE NOT TO SCALE):

(1) 1/4" Split Lock



(1) 1/2" Split Lock



(6) 3/8" Flat Washer



(12) .52" x 1.69" Washer



(1) 3/8" Star External



(2) Spacer, 3/8 x 1 1/2 x 0.5



MISCELLANEOUS:

(12) Clamp Bushings



(1) 3/64 x 6" Lanyard (part of head rest assembly)



(2) Spacer Tube (part of rear light bar assembly)



(4) Red reflectors
(2) Amber reflectors



2.6 Installation

NOTICE If you are adding the trailer option to a new unassembled LT15W sawmill, first assemble the sawmill bed as instructed in the LT15W operator's manual, then follow the steps below to install the trailer to the sawmill bed.

Have adequate manpower and lifting equipment to safely lift and stabilize the sawmill during installation.

1. Disassemble the feed rope from the front rope bracket, the feed crank pulley, and rear bracket.
2. Remove the rear feed rope bracket; retain the parts for re-installation. See Fig. 2-3.

WARNING: Use adequate lifting equipment to remove the saw head to the sawmill. Failure to do so may result in death or serious injury.

3. Move the saw head to the rear end of the bed and support with **lifting equipment** such as a forklift or hoist.

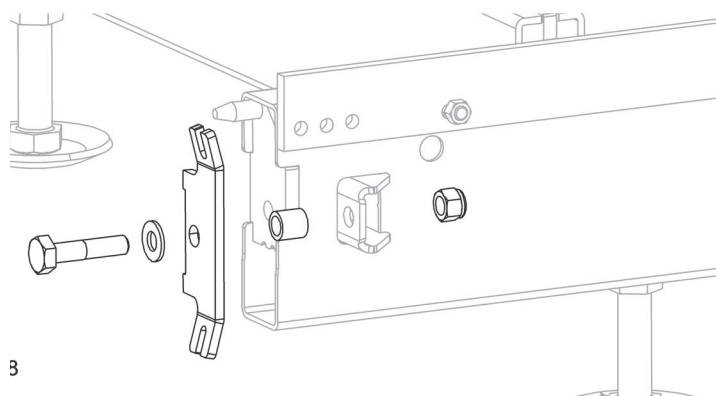

FIG. 2-3

4. Remove the saw head from the bed and set aside.

WARNING: Use adequate lifting equipment to lift the log bed. Failure to do so may result in death or serious injury.

5. Lift the sawmill log bed off the ground to remove the legs.
6. Remove the legs.

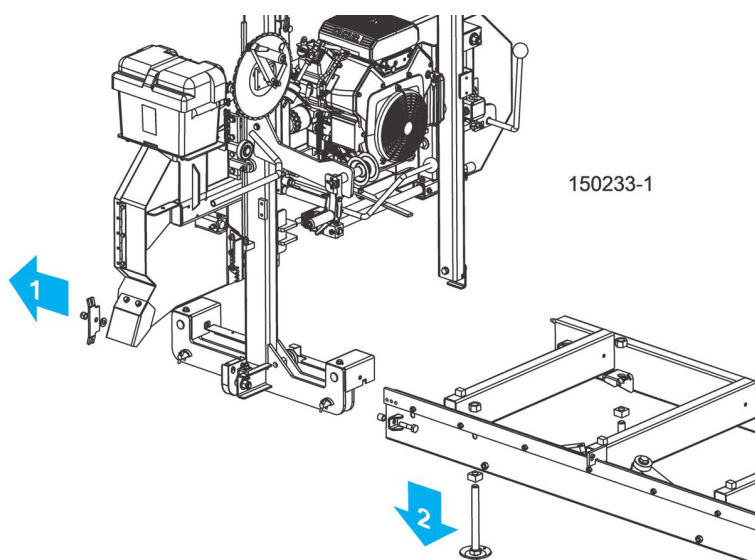
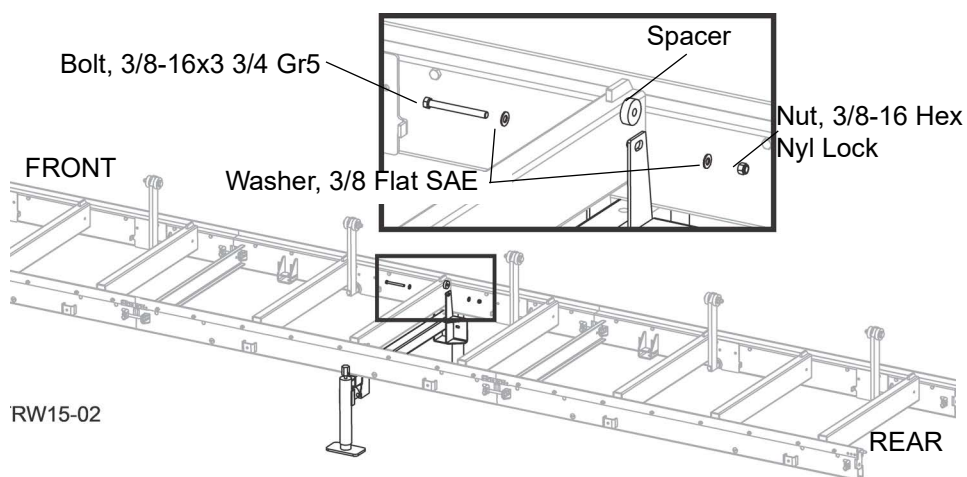

FIG. 2-4

7. Assemble the center jack assembly to the middle bed section as shown in Fig.2-5
8. Assemble the axle assembly to the middle bed section. See Fig. 2-5.

CAUTION! Chock both tires to prevent rolling.



9. Secure the axle assembly to the sawmill bed as shown in Fig. 2-5.

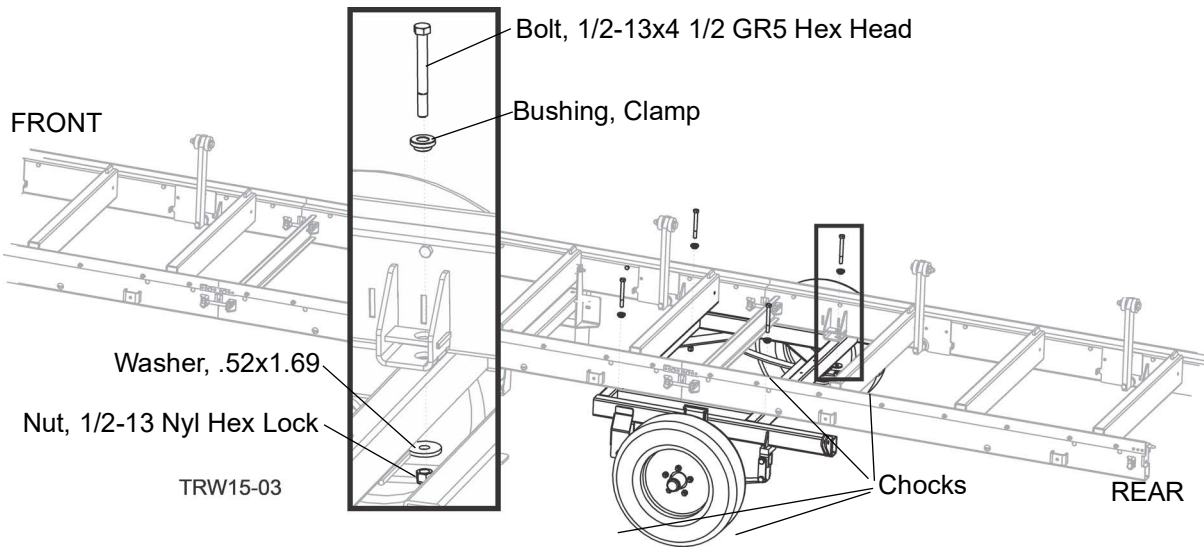

FIG. 2-5

10. Secure the rear jack assembly to the bed frame as shown in Fig. 2-6.

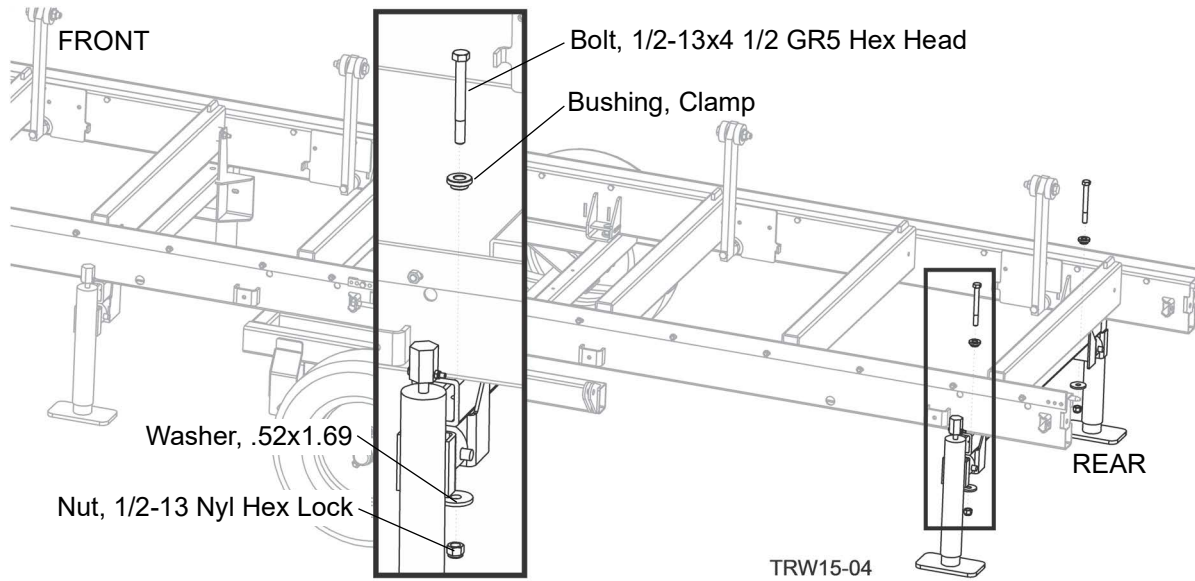

FIG. 2-6

11. Install the trailer brace weldment to the front end of the middle bed section as shown in Fig. 2-7.

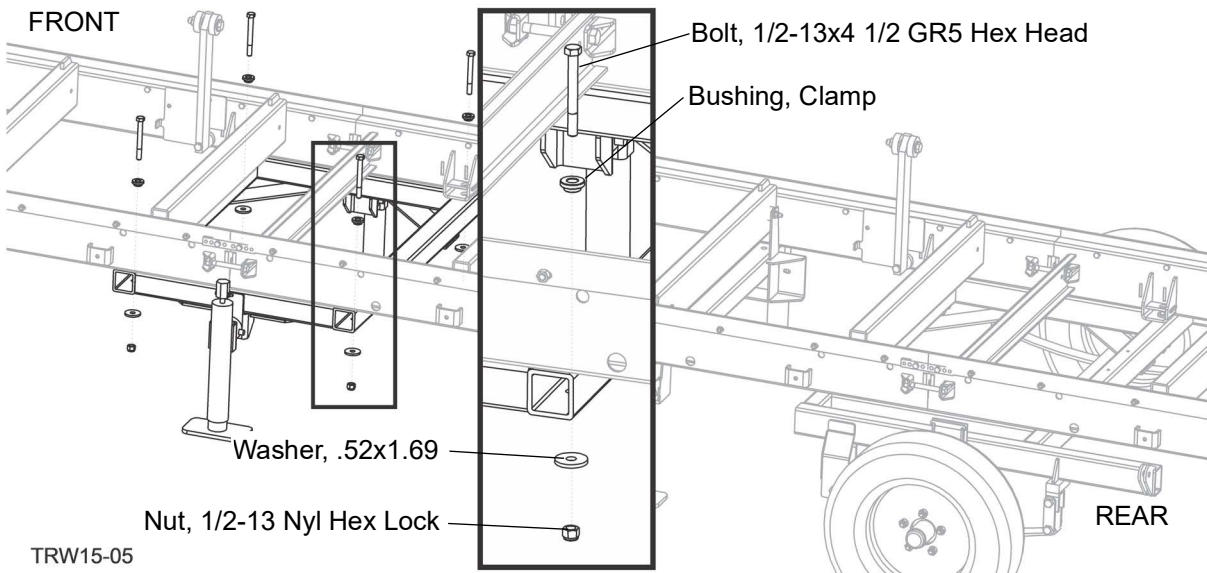

FIG. 2-7

12. Install the front jack assembly to the front bed section as shown in Fig. 2-9.



WARNING: Use adequate lifting equipment to replace the saw head to the sawmill. Failure to do so may result in death or serious injury.

13. Assemble the saw head to the sawmill.

14. Replace feed rope rear bracket.

NOTE: Leave the feed rope disassembled until trailer installation is complete.

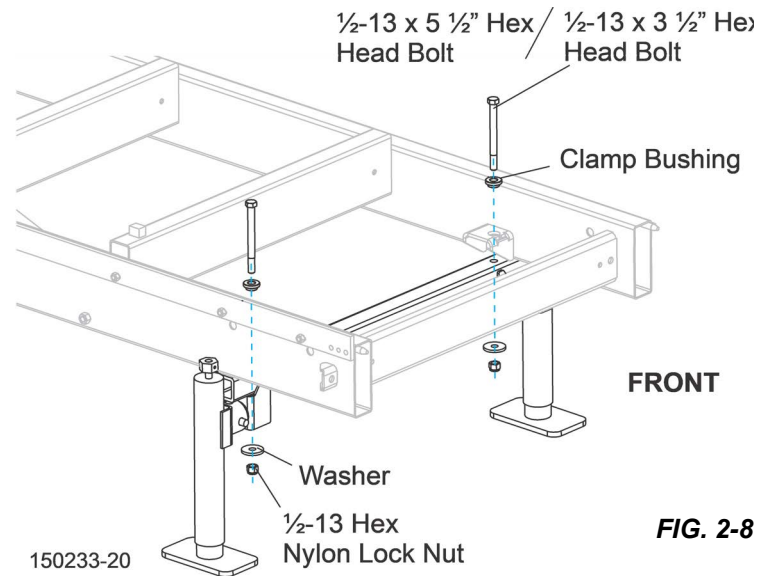

FIG. 2-8

2.7 Tongue Frame & Rear Light Bar Installation

Perform the following steps to install the rear light bar and the tongue frame to the trailer.

Install the light bar

1. Install the light bar to the sawmill bed as shown in Fig. 2-10.
2. Align the notches in the light bar with the sawmill bed rails. See Fig. 2-10.
3. Run a fish tape from the front end of the sawmill bed to the back to install the wire harness.
4. Route the main wiring harness inside the sawmill main bed tube from the light bar to the front. See Fig. 2-11.
5. Remove the front rope bracket and hardware from the sawmill bed.

NOTE: Retain the bushing, washer, and rope bracket for re-installation.

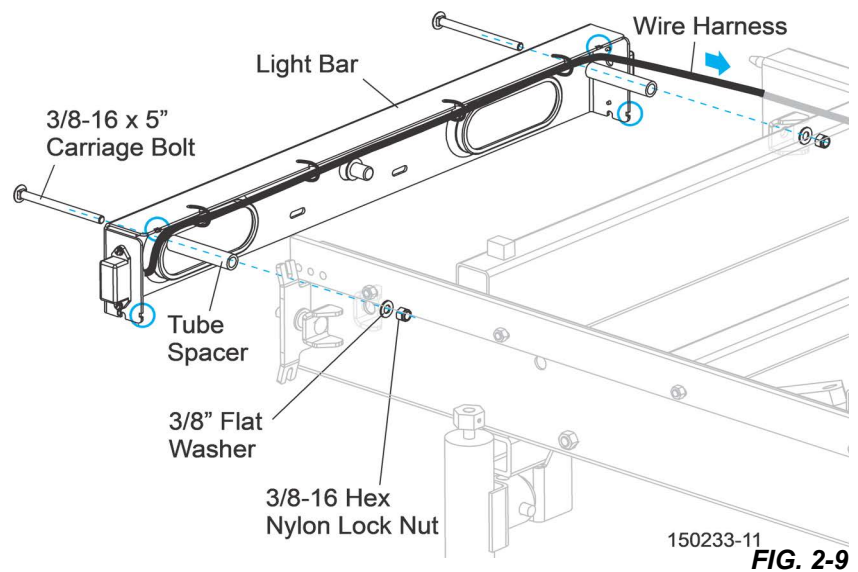

FIG. 2-9

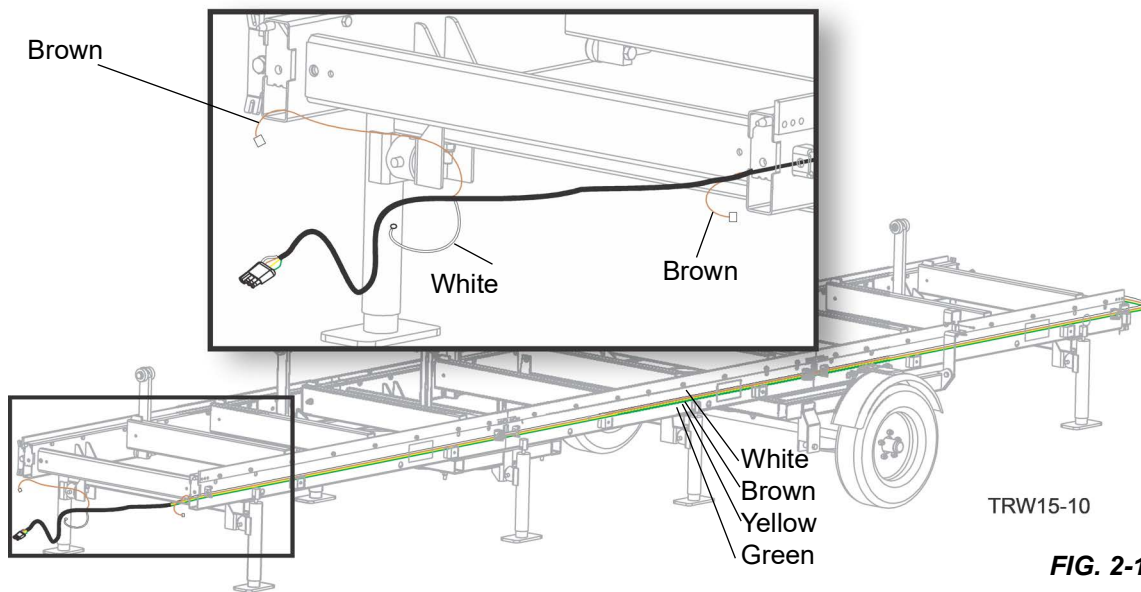

FIG. 2-10

Install the tongue frame

1. Feed the wiring harness through the space on the tongue weldments allotted for the wiring harness to pass through. See Fig. 2-10.

NOTE: Do not pinch the wires during installation.

NOTE: The brown wire to the nearest clearance light is short and may have remained inside the main bed tube.

1. Tighten the tongue weldment, starting at the front rope bracket in order to assure the proper alignment. See Fig. 2-11.
2. Reuse the rope bracket, washer, and bushing removed previously.
3. Do not reuse the nylon lock nut; a new nut is provided.

NOTE: The bolt for the bracket is different than the other three bolts.

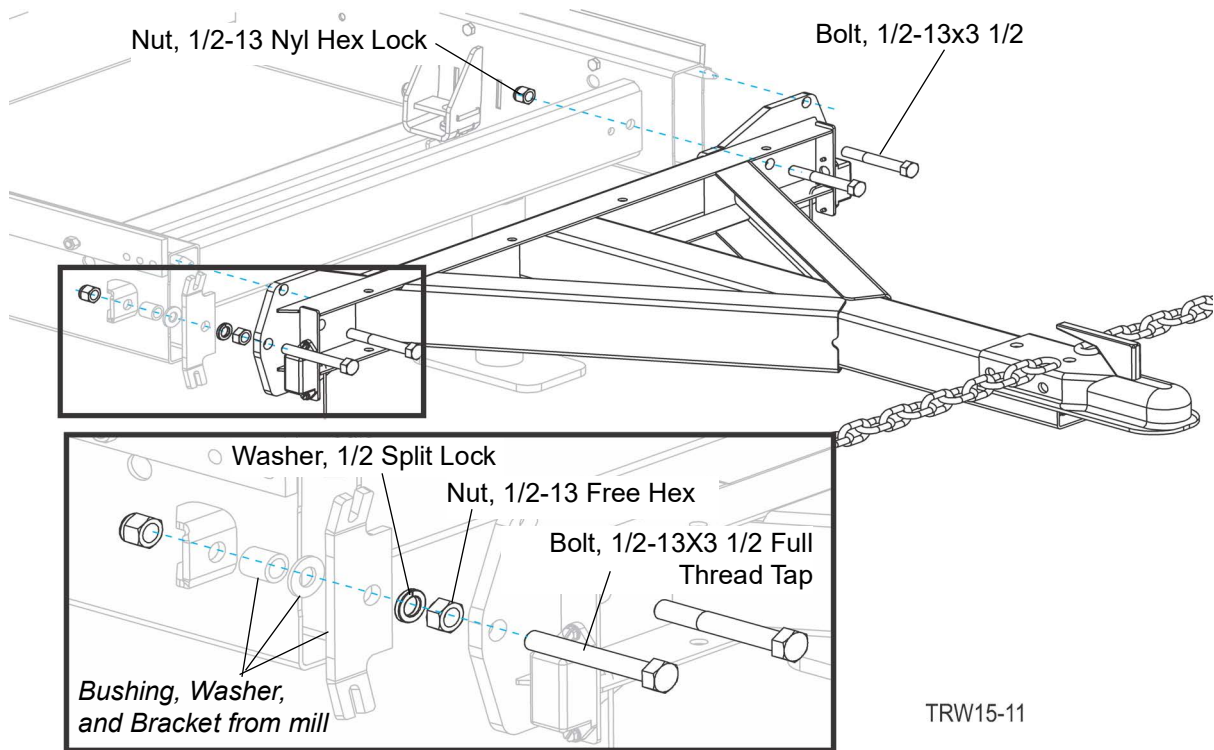

FIG. 2-11

4. Connect the two brown wires from the harness to the black wires on the clearance lights.
5. Connect the white ground wire to the ground bolt under the hitch and secure with the provided nut. See Fig. 2-14.

NOTICE Make sure the serrated star washer breaks through the paint on the hitch.

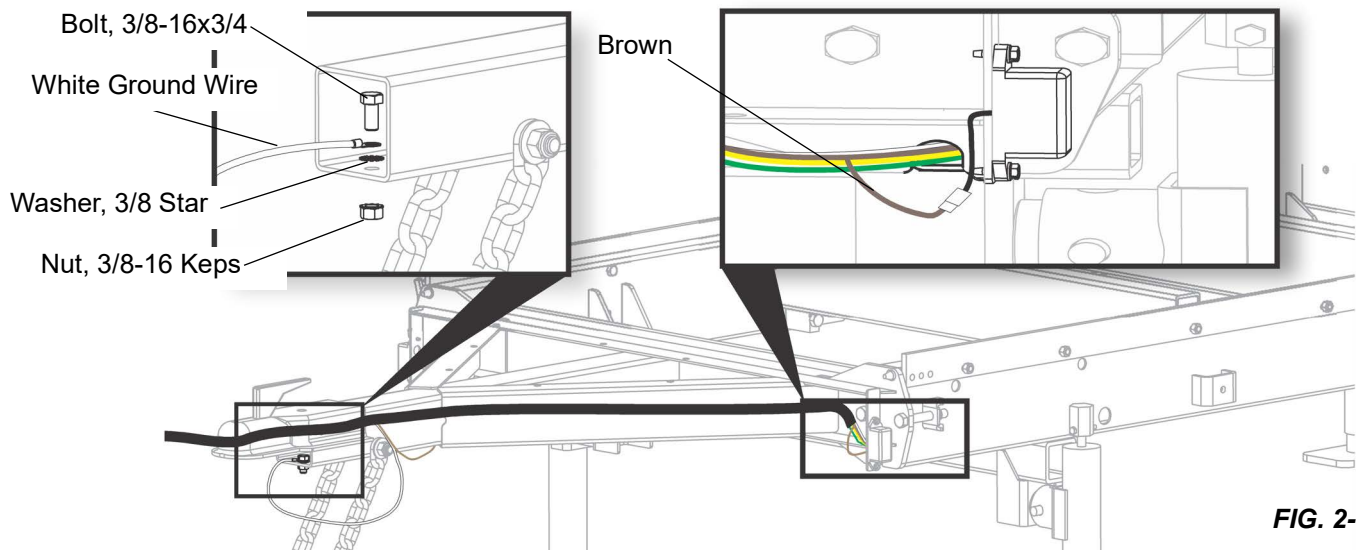
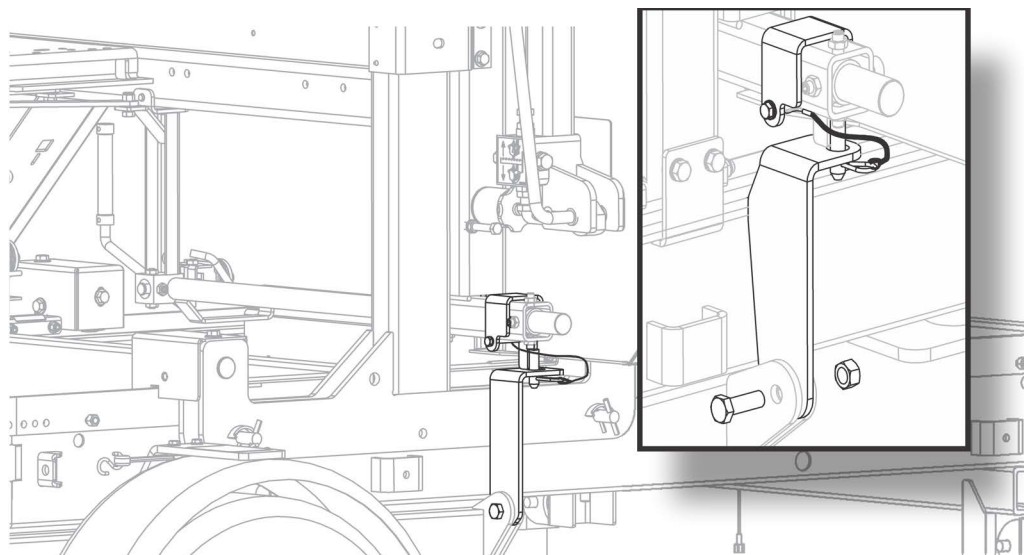

FIG. 2-12

6. Secure the harness and running light wires with wire ties.

2.8 Final Installation

1. Install the provided saw head rest pin to the blade guide arm housing with the 1/4-20 x 2 3/4" hex head bolt, split lock washer, lanyard and safety pin.
2. Install the head rest plate to the sawmill bed. See Fig. 2-13..



TRW

FIG. 2-13

3. Install the trailer fenders to the trailer and secure with the locking straps.

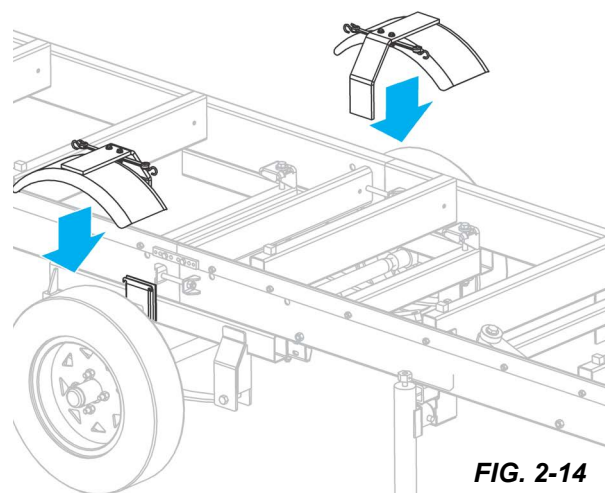

FIG. 2-14

4. Install the two provided red reflectors on each side of the saw head. See Fig. 2-15.

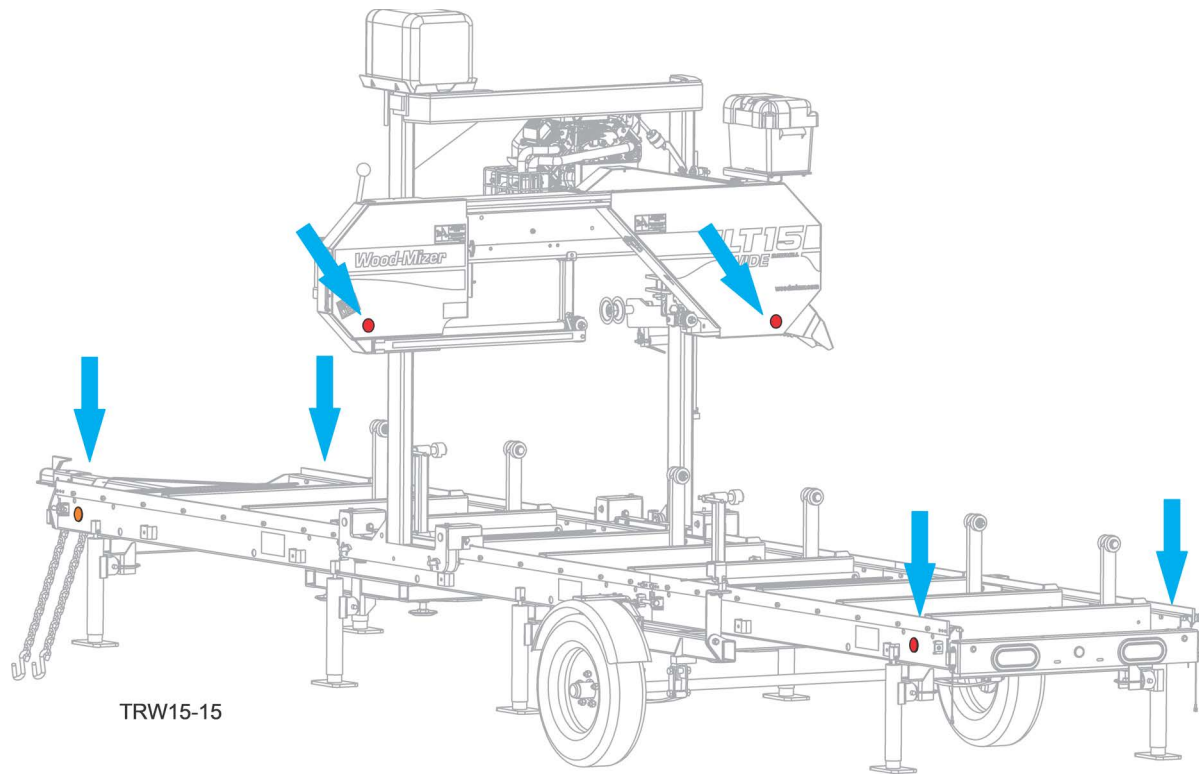

FIG. 2-15

5. Install the two provided amber (hitch end) and red reflectors (tail end) on each side of the sawmill bed. See Fig. 2-15.
6. Reinstall the feed rope; refer to your Operator's Manual for re-installation and mill alignment.

SECTION 3 TRAILER OPERATION

3.1 Prepare For Travel

NOTICE Your vehicle should be equipped with a Class 2 hitch with a solid 2" ball (not two-piece) and rated for at least 3500 pounds (1588 kg). The hitch should be correctly mounted to the towing vehicle so that it will be able to pull this type of load.

1. Move the saw head to the front of the sawmill and raise the rear jacks.
2. Disconnect the water hose.
3. Remove the water tank from the saw head mast.



WARNING! Secure the saw head in the travel position before towing the sawmill. Failure to do so may result in damage to the machine.

4. Replace the fenders in the brackets behind each wheel and secure with the locking straps. See Fig. 1-1.
5. Move the saw carriage to the travel position and secure the travel lock pins. See Fig. 1-2.
6. Align the head with the head rest plate and lower the saw head until the pin engages the bracket. See Fig. 1-2.

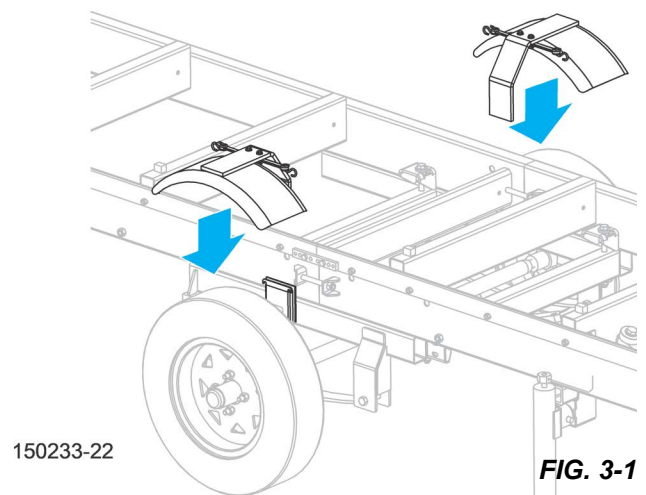

FIG. 3-1

7. Secure with the safety pin. See Fig. 1-2.
8. *If the options are included*, place log loading ramps in the towing vehicle. Raise the winch to upright position.
9. Rotate all but the very front jacks to the travel position.
10. Align the mill behind the towing vehicle and place the hitch over the ball coupling on your vehicle.
11. Adjust the front jacks to lower the trailer until the hitch engages the ball.
12. Adjust the coupler if necessary so it is as tight as possible on the ball and the locking lever can still be opened and closed.
13. Flip the locking handle downward being sure the bracket underneath firmly clamps around the ball.
14. Secure the locking handle with the safety pin.

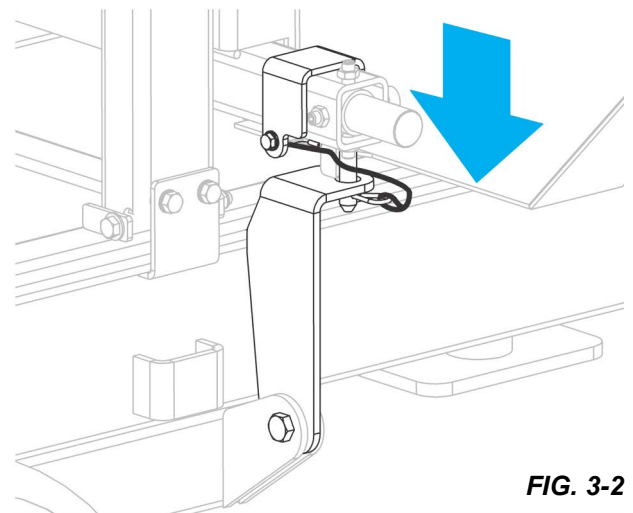

FIG. 3-2



WARNING! Ensure hitch bracket is securely fastened around ball before towing the sawmill. Ball should be completely engaged by the hitch bracket and securely locked in place. Use the hitch only with the specified ball size. Failure to do so may result in serious personal injury and/or severe machine damage.



WARNING! Ensure your towing vehicle has adequate safety chain hookups. **DO NOT USE EYEBOLTS FOR SAFETY CHAIN HOOK-UP.**

Safety chains should be hooked to bumper of vehicle so that each chain would pull the trailer equally in the event the hitch became disengaged. Failure to do so may result in serious personal injury and/or severe machine damage.

15. Cross the safety chains underneath the hitch and hook to the vehicle.

NOTICE The chains should be connected so that there is still slack in the chains when the vehicle is turned sharply in either direction.

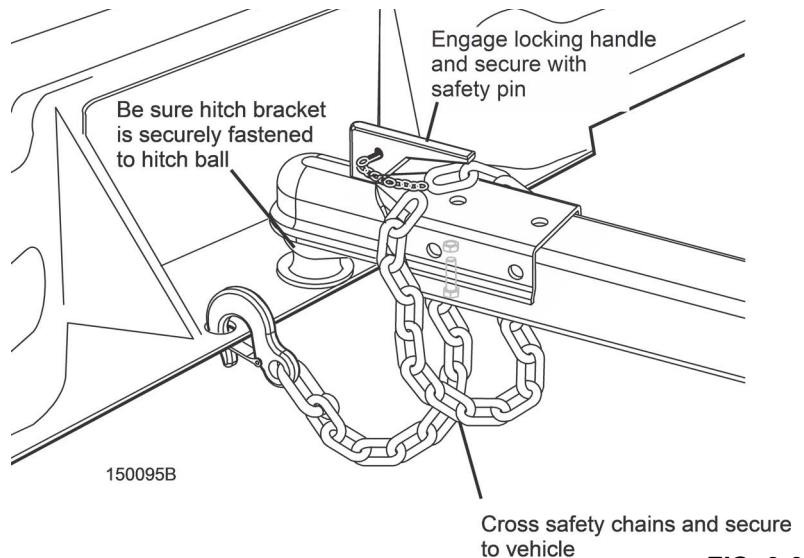

FIG. 3-3

16. Connect the trailer light harness to the towing vehicle light plug.
17. Rotate the front jacks all the way up into the travel position.
18. Recheck that all loose items are removed or secured (such as cant hooks, etc.).
19. Make sure all connections are secure and trailer lights are working properly.



DANGER! Ensure that the hitch and safety chains are secure before towing the sawmill. Failure to do so will result in serious personal injury and/or severe machine damage.



WARNING! Ensure all light connections have been made and are working properly before towing the sawmill. Failure to do so may result in serious personal injury and/or severe machine damage.

Review and comply with all applicable Federal State and Local motor vehicle safety laws.

20. Check tires for proper inflation.



WARNING! Always check trailer tires for proper inflation before towing sawmill. Failure to do so may lead to tire failure resulting in property damage and/or serious injury or death.

3.2 Prepar For Operation



WARNING! Do not set up the mill on ground with more than a 10 degree incline. Setting up the mill on an incline could cause it to tip over resulting in serious personal injury.

If setup on an incline is necessary put blocks under one side of the mill or dig out areas for jacks to keep mill level.

Chock the trailer wheels to prevent movement before unhitching it from the towing vehicle.

Ensure the trailer is supporting the sawmill frame when operating a sawmill with jacks. The jacks are intended to support the saw frame with assistance from the trailer.

The jacks supplied with portable sawmills are not intended for setup on concrete or other hard surfaces. Long-term use of the jacks on hard surfaces may cause the jacks to fail causing the sawmill to drop resulting in possible serious injury or death.

If setting the sawmill up on concrete or other hard surface replace the jacks with stationary legs.

Put front jack down before moving cutting head from the rest position.

1. Position the sawmill in an area that is suitable for sawing.
2. Chock the trailer wheels to prevent movement while unhitching the trailer.
3. Unhook the safety chains and light harness from the vehicle and unhitch the sawmill.
4. Lower the front jacks and set on the ground.
5. Remove the saw head safety pin and raise the saw head from the rest bracket.
6. Remove the rest bracket from the sawmill bed.
7. Move the saw carriage to the front of the sawmill and lower the remaining jacks.
8. Use the provided crank handle to adjust the jacks to lift weight from the trailer axle and level the sawmill.
9. Disengage the fender locking straps and lift the fenders from the trailer and set aside.
10. Install the water tank and hose to the mill.

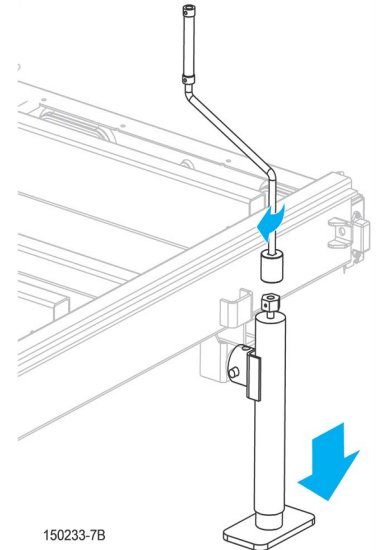

FIG. 3-4

3.3 Loading, Turning, And Clamping Logs

MAXIMUM WEIGHT FOR LOGS IS 4200 LBS. Note that the numerous species can exceed this limit when cut to the maximum size capacity of the mill (36" diameter x 212" (17'8")).

CAUTION! Consider limiting all logs to 168" (14') to avoid overloading the sawmill. For most species, a log with 36" diameter and 168" (14') in length will be under the maximum weight. Failure to follow this may result in machine damage.

LOADING LOGS

1. Move the saw carriage to the front end of the frame.

CAUTION! Before loading a log, ensure the cutting head is moved far enough forward so the log does not hit the head, resulting in machine damage.

2. Adjust the log clamps all the way down and move them toward the loading side of the sawmill frame.

NOTE: The clamps can be lifted and removed from the bracket assemblies to avoid damage to the clamp when loading a log.

CAUTION! Ensure the log clamps are adjusted out of the path of the log before loading a log onto the bed.

3. Raise the side supports on the sawmill bed to prevent the log from falling off the side of the bed.
4. Load the log onto the mill with a tractor, fork lift, or other loading equipment.

CAUTION! Do not allow the log to drop from a height when unloading. Use care in lowering a log onto the log bed to prevent machine damage.

TURNING LOGS

5. Use a tractor, fork lift, or other loading equipment to turn the log when it is on the bed.

CLAMPING LOGS

Ensure the side supports and clamp are positioned low enough for the blade to pass over them.

6. Slide the clamp against the log and turn the locking handle to lock the clamp against the log.
7. Refer to the your Operator's Manual for further cutting instructions.

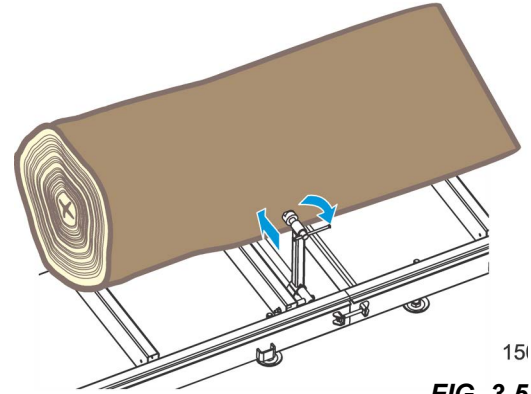

15

FIG. 3-5

SECTION 4 MAINTENANCE

1. Grease the trailer axle wheel bearings with lithium grease every 3 months or 1000 miles (1609 km) whichever comes first.
2. Ensure that the trailer tires are correctly inflated to the pressure shown on the tire.



CAUTION! Always check trailer tires for proper inflation before towing sawmill. Failure to do so may result in machine damage.

3. Check the adjustment of the trailer hitch coupler bracket frequently and adjust if necessary.
4. Replace any bent or otherwise damaged parts before using the hitch.
5. Use only parts provided by the hitch manufacturer for this hitch model.

SECTION 5 REPLACEMENT PARTS

5.1 Trailer (Complete)

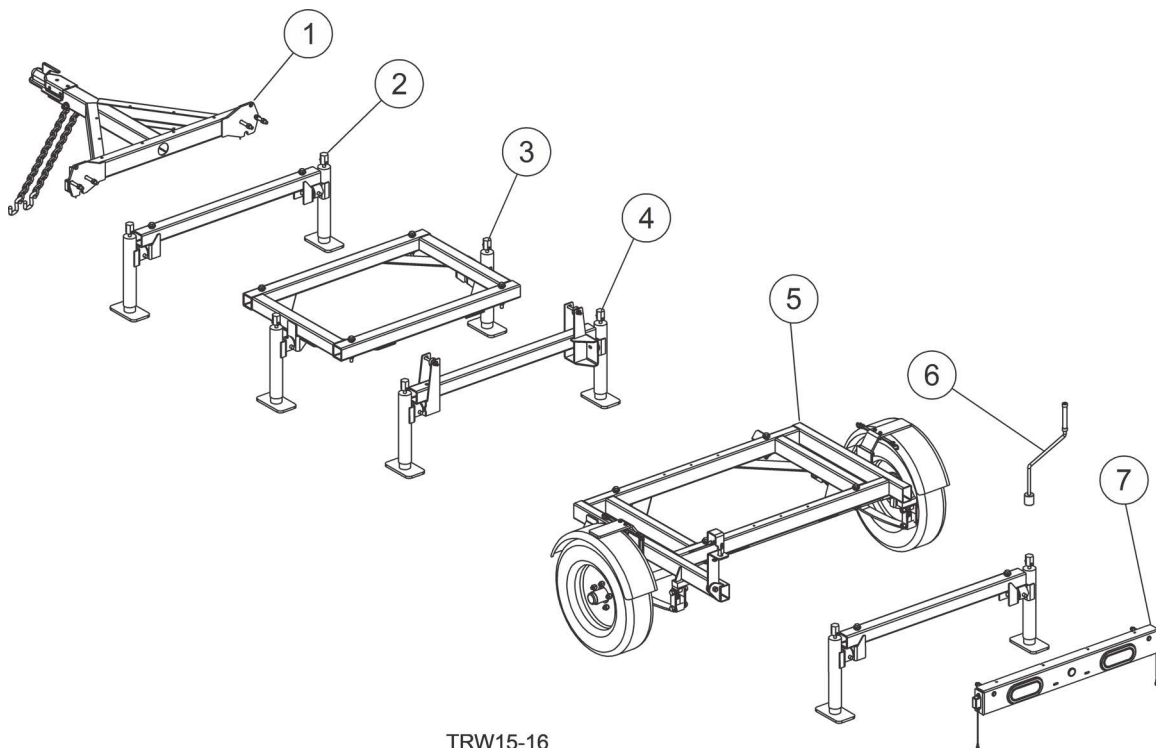

TRW15-16

REF	PART #	DESCRIPTION	COMMENTS	QTY.
	123084	Assy, LT15Wide Trailer		1
1	123085	Assy, LT15WTR Tongue	See Section 5.2	1
2	123074	Jack Assy, LT15W Trailer	See Section 5.3	2
3	123158	Assy, LT15W Trailer Brace	See Section 5.4	1
4	123080	Jack Assy, LT15W Center	See Section 5.5	1
5	123159	Assy, LT15W Trailer Axle	See Section 5.6	1
6	056831	Handle Assy, Adj. Outrigger Crank	See Section 5.8	1
7	123078	Assy, LT15W Rear Light Bar	See Section 5.9	1
	074647	Wire Harness, Trailer Lights	See Section 5.10	1

5.2 Tongue Assembly

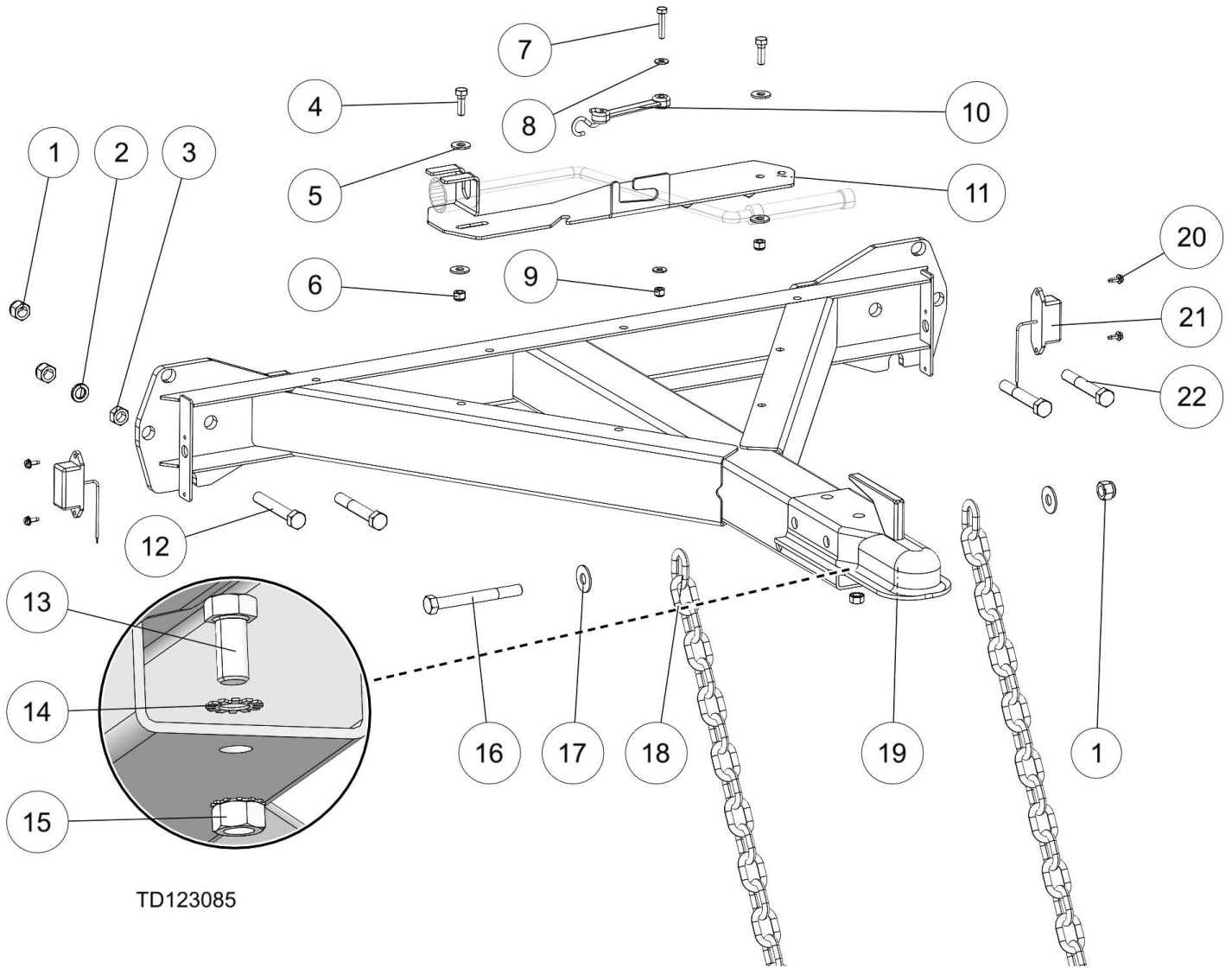

REF	PART #	DESCRIPTION	COMMENTS	QTY.
	123085	Assy, LT15WTR Tongue		1
1	F05010-8	Nut, 1/2-13 Nyl Hex Lock		5
2	F05011-9	Washer, 1/2 Split Lock		1
3	F05010-35	NUT, 1/2-13 FREE HEX, ZINC		1
	133113	Assy, Wrench Bracket	Added 4/2022 per ECN 38500	1
4	F05006-1	Bolt, 5/16-18x1 HH Gr2		2
5	F05011-16	Washer, 5/16 Standard Flat		4
6	F05010-58	Nut, 5/16-18 Nyl Lock		2
7	F05005-3	Bolt, 1/4-20x1 1/4 HH		1
8	F05011-11	Washer, 1/4 SAE Flat		2
9	F05010-69	Nut, 1/4-20 Nylock		1
10	016542	Strap, Rubber 6		1
11	133098	Bracket, Wrench Mount		1

5 Replacement Parts

Tongue Assembly

REF	PART #	DESCRIPTION	COMMENTS	QTY.
12	F05008-11	BOLT, 1/2-13X3 1/2 FULL HEX HEAD, ZN		1
13	F05007-118	Bolt, 3/8-16x3/4 HH Gr5		1
14	F05011-36	Washer, 3/8 Star External		1
15	F05010-19	Nut, 3/8-16 Keps		1
16	F05008-35	Bolt, 1/2-13x4 1/2 GR5 Hex Head		1
17	F05011-35	WASHER, 7/16 STANDARD FLAT		2
18	107163	Chain, 30 Inch Safety		1
19	123082	Hitch Wldmt, LT15W		1
20	F05015-7	Bolt, #10-24x1/2 Self Tap		4
21	P12906	Lamp, Running Amber		2
22	F05008-61	Bolt, 1/2-13x3 1/2 Hex Head GR5 Zinc		3
23	F05092-23	Terminal 3/8 10-12Ga Ring NI		1

5.3 Front and Rear Jack Assemblies

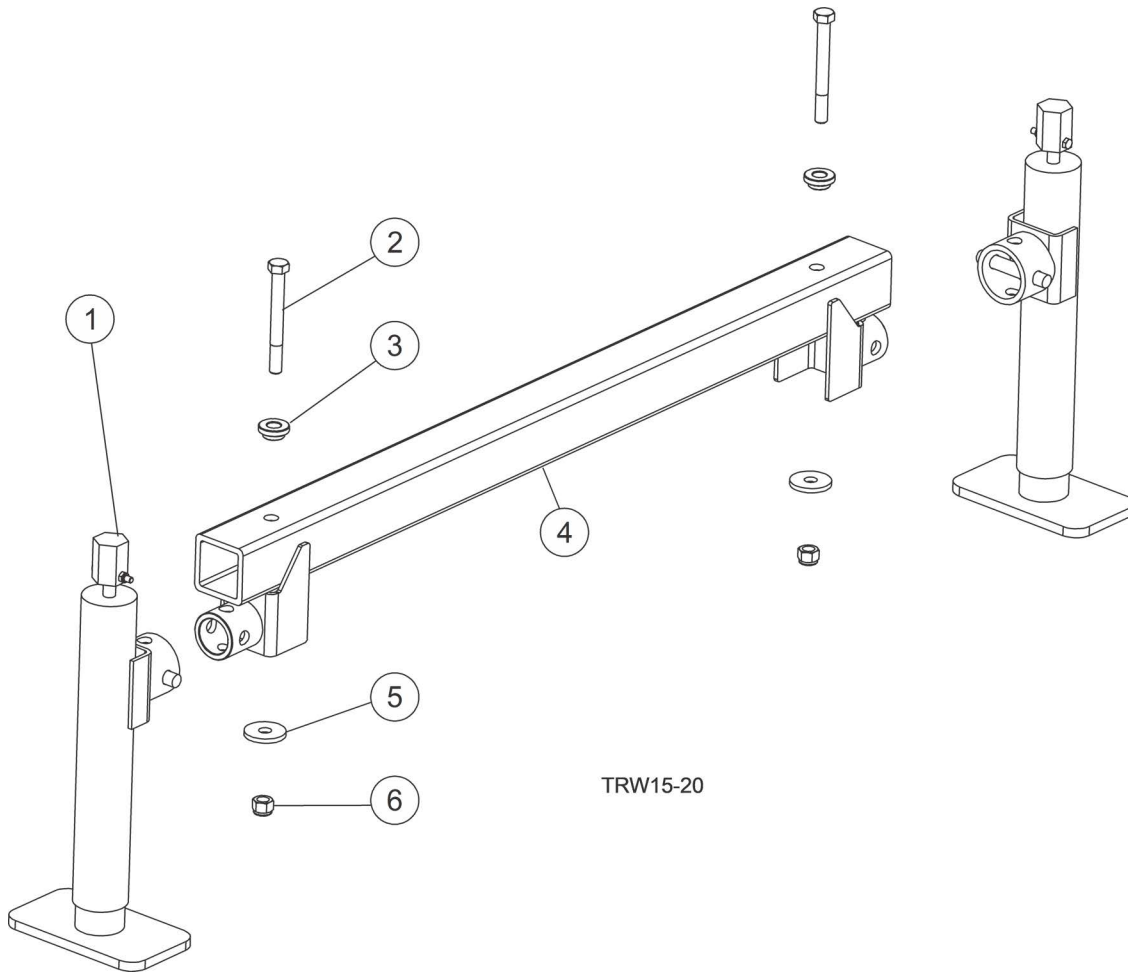

REF	PART #	DESCRIPTION	COMMENTS	QTY.
	123074	Jack Assy, LT15W Trailer		
1	076225	Assy, Jack LT15 Adjustable	See Section 5.8	2
2	F05008-35	Bolt, 1/2-13x4 1/2 HH Gr5		2
3	062461	Bushing, Clamp		2
4	123075	Weldment, LT15W Jack		1
5	014632	Washer, .52x1.69		2
6	F05010-8	Nut, 1/2-13 Nyl Hex Lock		2

5.4 Trailer Brace Assembly

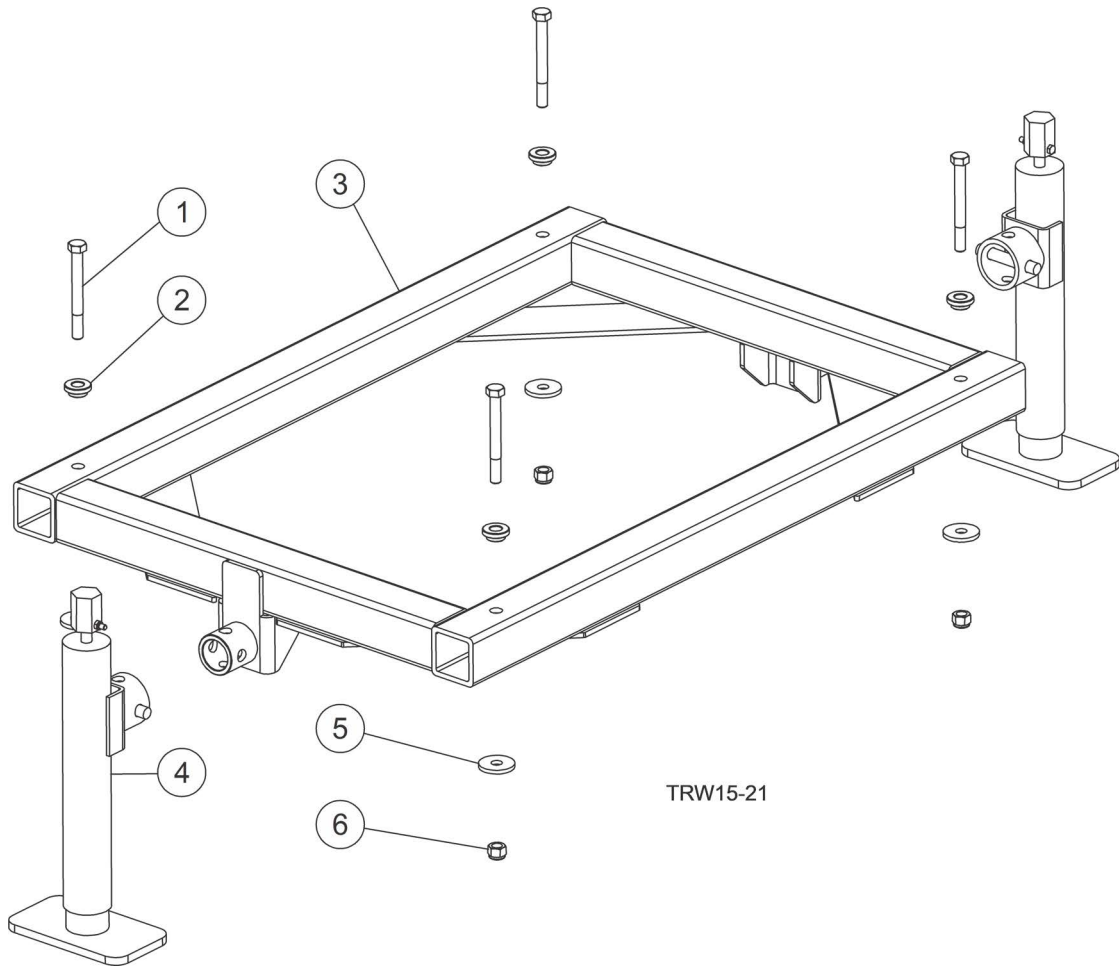

REF	PART #	DESCRIPTION	COMMENTS	QTY.
	123158	Assy, LT15W Trailer Brace		
1	F05008-35	Bolt, 1/2-13x4 1/2 HH Gr5		4
2	062461	Bushing, Clamp		4
3	123072	Weldment, LT15W Trailer Brace		1
4	076225	Assy, Jack LT15 Adjustable	See Section 5.8	2
5	014632	Washer, .52x1.69		4
6	F05010-8	Nut, 1/2-13 Nyl Hex Lock		4

5.5 Center Jack Assembly

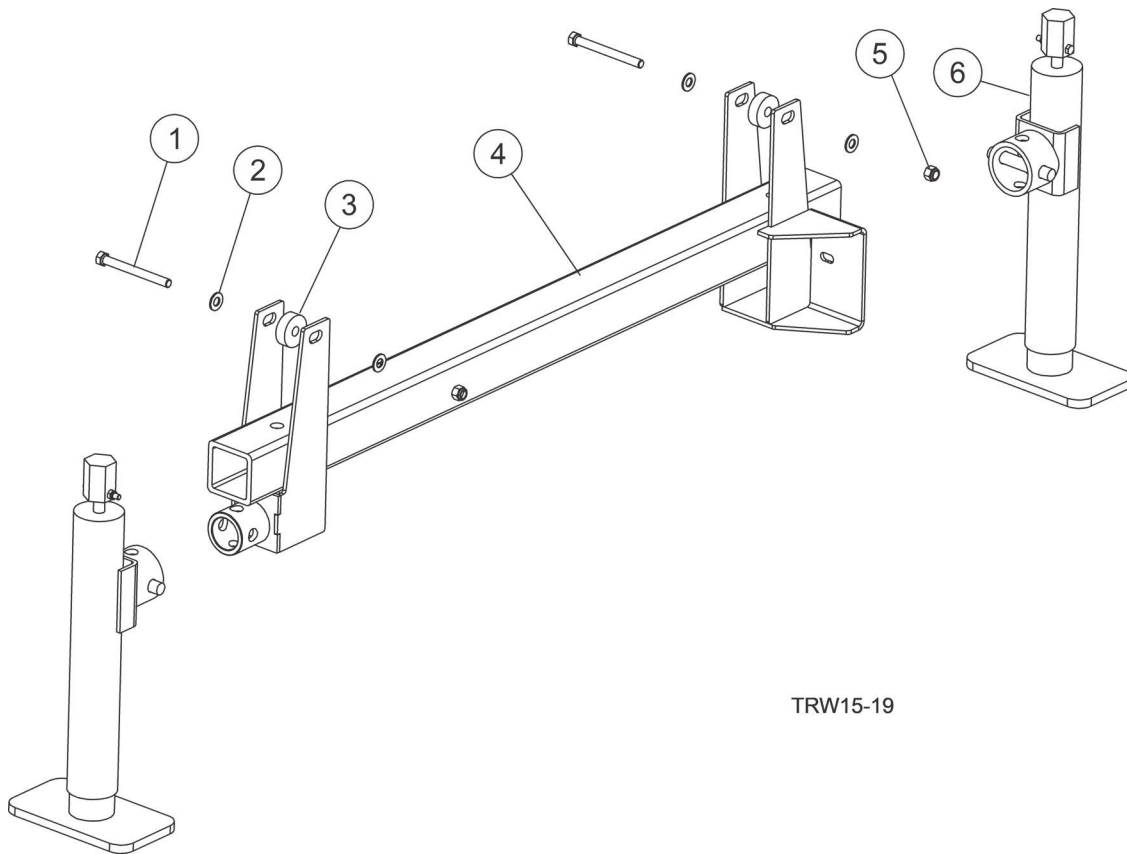

TRW15-19

REF	PART #	DESCRIPTION	COMMENTS	QTY.
	123080	Jack Assy, LT15W Center		
1	F05007-136	Bolt, 3/8-16x3 3/4 HH Gr5		2
2	F05011-3	Washer, 3/8 Flat SAE		4
3	123160	Spacer, 3/8 ID x 1 1/2 OD x 0.5 LNG		2
4	123081	Weldment, LT15W Center Jack		1
5	F05010-10	Nut, 3/8-16 Hex Nyloc		2
6	076225	Assy, Jack LT15 Adjustable	See Section 5.8	2

5.6 Trailer Axle Assembly

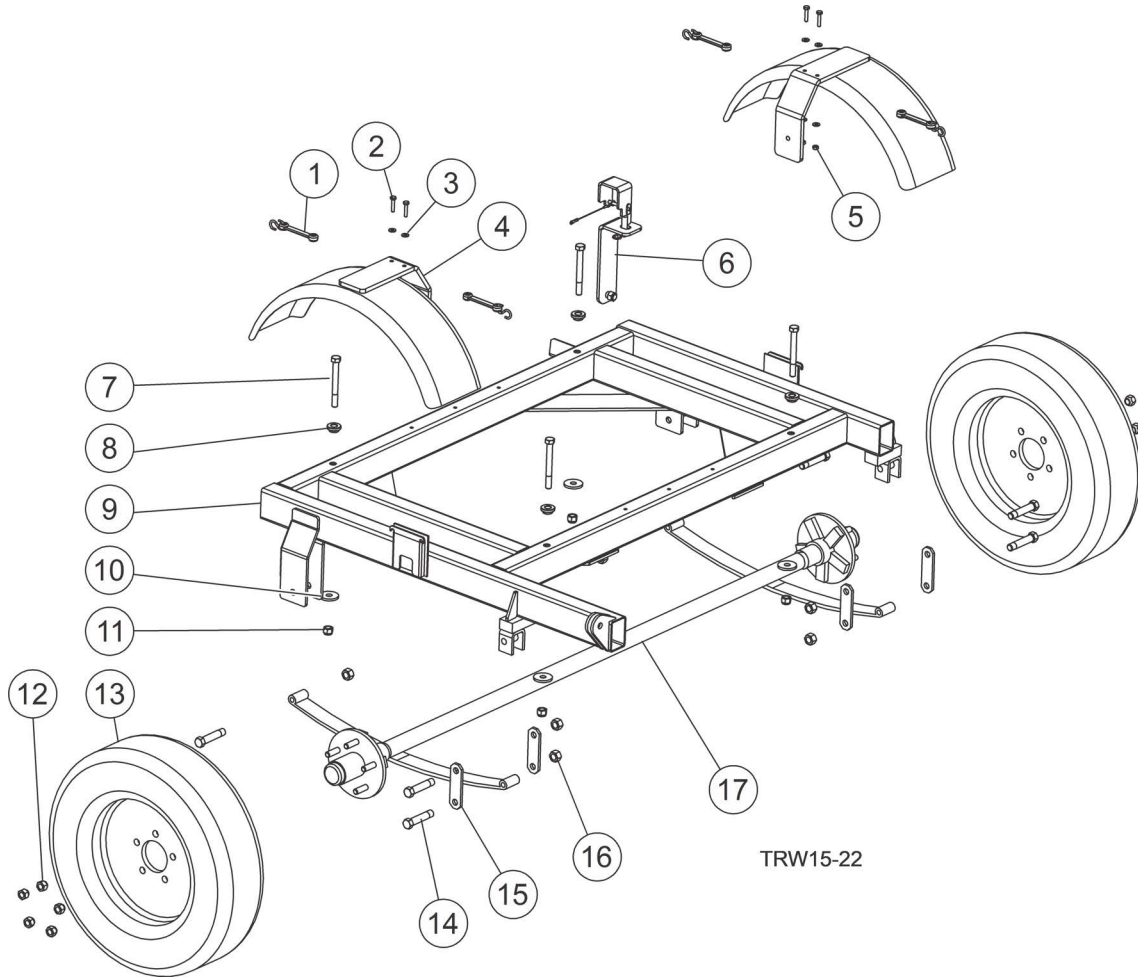

REF	PART #	DESCRIPTION	COMMENTS	QTY.
	123159	Assy, LT15W Trailer Axle		
	123161	Fender Assy, LT15WTR		2
1	016542	Strap, Rubber 6		2
2	F05011-11	Washer, 1/4 SAE Flat		4
3	F05005-3	Bolt, 1/4-20x1 1/4 HH FT Cap		2
4	123162	Weldment, LT15 Trailer Fender		1
5	F05010-21	Nut, 1/4-20 Swaged		2
6	123115	Assy, Head Rest		1
7	F05008-35	Bolt, 1/2-13x4 1/2 HH Gr5		4
8	062461	Bushing, Clamp		4
9	123076	Weldment, LT15W Trailer Axle		1
10	014632	Washer, .52x1.69		4
11	F05010-8	Nut, 1/2-13 Nyl Hex Lock		4
12	P04646	Nut, 1/2-20 Lug		10
13	133595	Tire Wheel Assy, ST145/75R12, Tamarack		2
14	P04644	Bolt, 9/16-18		6
15	M07528	Plate, Axle Shackle Link Ptd		4
16	P04643	Nut, 9/16-18 Lock		6
17	P09772	Axle, 3500Lb W/Spring		1

5.7 Head Rest Assembly

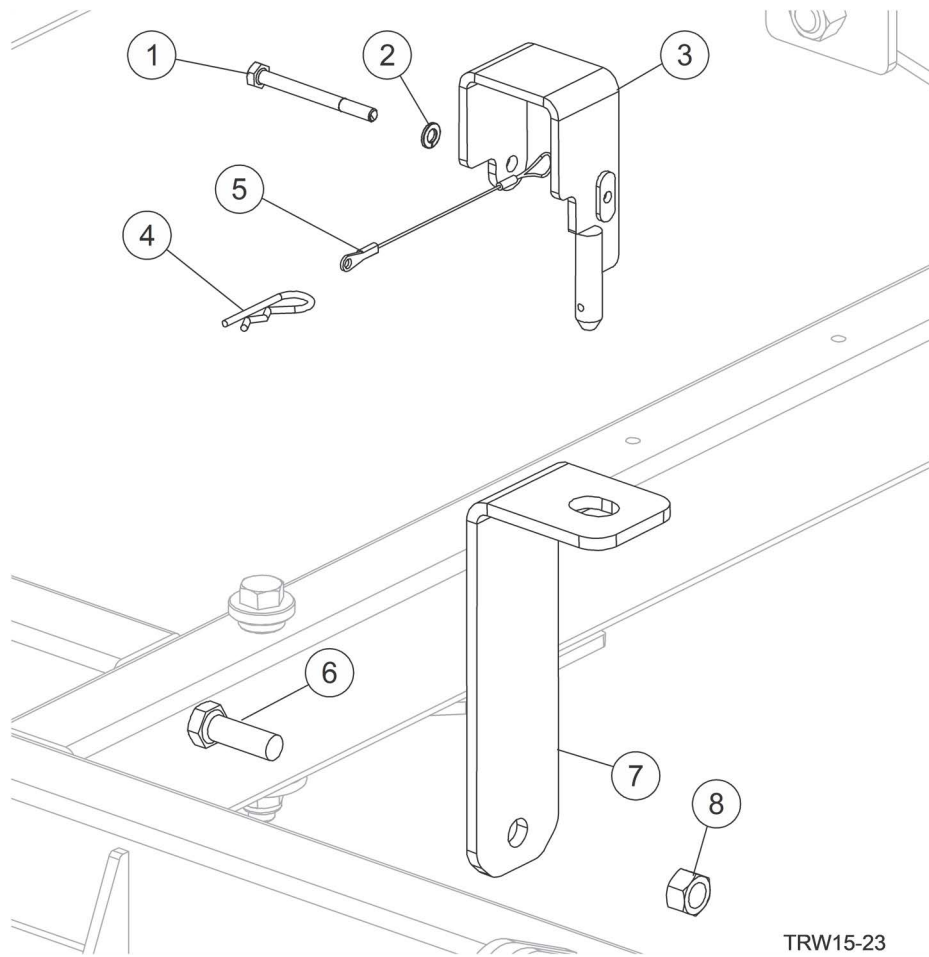

TRW15-23

REF	PART #	DESCRIPTION	COMMENTS	QTY.
	123115	Assy, Head Rest		
1	F05005-18	Bolt, 1/4-20x2 3/4 HH Gr5		1
2	F05011-14	Washer, 1/4 Split Lock		1
3	059490	Weldment, LT15 Rest Pin		1
4	P05059	Pin, 1/8x1 13/16 Safety		1
5	016030	Lanyard, 3/64 x 6		1
6	F05008-33	Bolt, 1/2-13x1 1/2 HH Gr5		1
7	123114	Bracket, Head Rest		1
8	F05010-3	Nut, 1/2-13 Swaged Hex		1

5.8 Crank Handle and Adjustable Jack Assembly

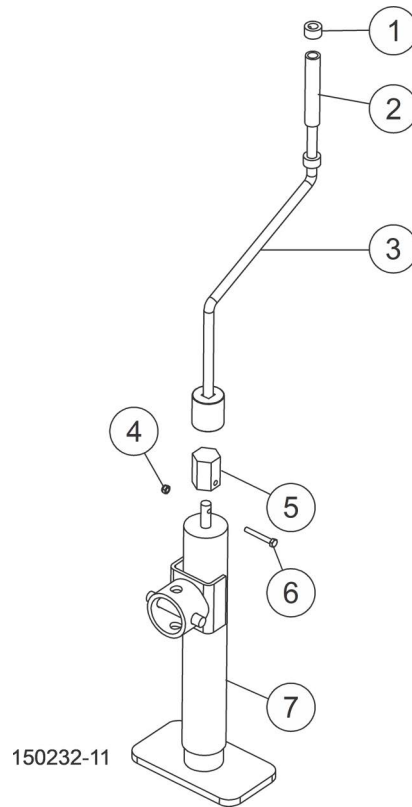

REF	PART #	DESCRIPTION	COMMENTS	QTY.
	056831	Handle Assembly Adjustment jack Crank		1
1	014820	Collar Lock 1/2IDx7/8OD		2
2	056830	Tube, Outrigger Crank Handle		1
3	056827	Crank Weldment Adjustment Jack		1
	076225	Assy, Jack LT15 Adjustable		
4	F05010-200	Nut, M6-1.0 Nylon Lock		1
5	076224	Nut, Jack Hex 1-1/4 x 1/2 ID		1
6	F05020-28	Bolt, M6-1.0x45 HH Class 8.8		1
7	110403	Jack. 10" w/ Pin Only		1

5.9 Rear Light Bar

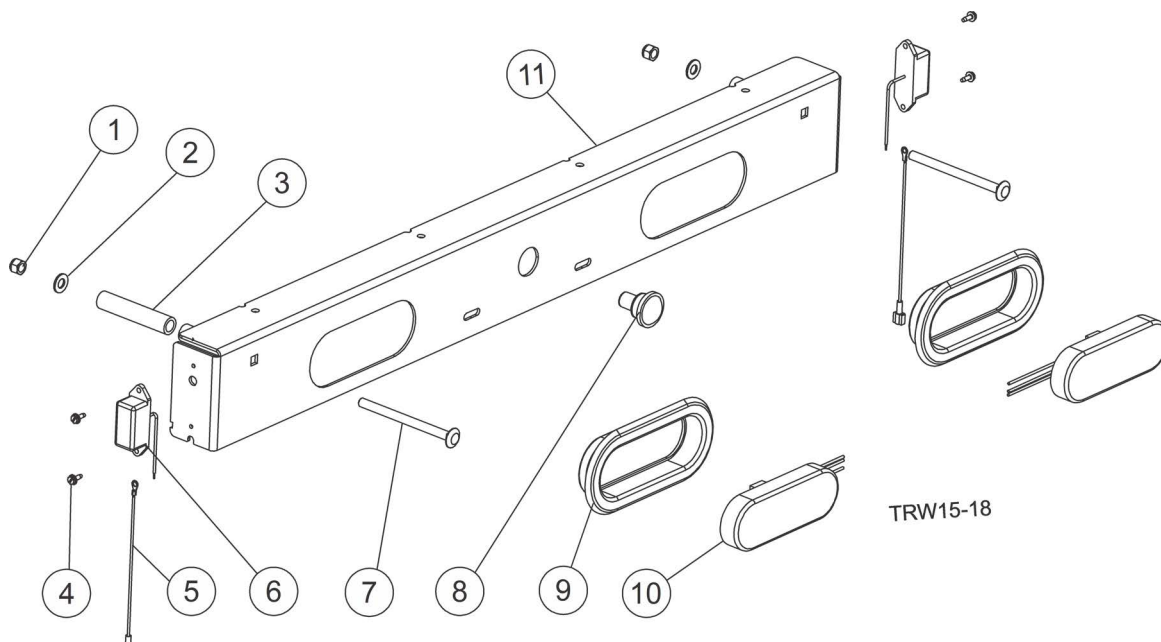

REF	PART #	DESCRIPTION	COMMENTS	QTY.
	123078	Assy, LT15W Rear Light Bar		
1	F05010-10	Nut, 3/8-16 Hex Nyloc		2
2	F05011-3	Washer, 3/8 Flat SAE		2
3	074663	Tube, Spacer LT15 Trailer		2
4	F05015-7	Bolt, #10-24x1/2 Self Tap		4
5	074617	Assy, Ground Wire LT15GO2		2
6	P12905	Lamp, Running Red		2
7	F05007-113	Bolt, 3/8-16x5 Carriage		2
8	P09928	Lamp, 1 1/4 License Plate		1
9	006688	Grommet, 6 1/2 Light Mounting		2
10	006391	Light, LED Tail		2
11	123079	Plate, LT15W Rear Light Bracket		1

5.10 Wiring Harness

