

Laser Sight

Safety, Operation, Maintenance & Parts Manual

LS for 1992-96 Sawmills rev. A.00 - D.01



Safety is our #1 concern! Read and understand all safety information and instructions before operating, setting up or maintaining this machine.

March 1997

Form #900



WARNING! Read and understand this manual before using this machine.

California
Proposition 65 Warning



WARNING: Breathing gas/diesel engine exhaust exposes you to chemicals known to the State of California to cause cancer and birth defects or other reproductive harm.

Always start and operate the engine in a well-ventilated area.
If in an enclosed area, vent the exhaust to the outside.
Do not modify or tamper with the exhaust system.
Do not idle the engine except as necessary.

For more information go to **www.P65warnings.ca.gov**.



WARNING: Drilling, sawing, sanding or machining wood products can expose you to wood dust, a substance known to the State of California to cause cancer. Avoid inhaling wood dust or use a dust mask or other safeguards for personal protection.

For more information go to **www.P65Warnings.ca.gov/wood**.

Active Patents assigned to Wood-Mizer, LLC

Wood-Mizer, LLC has received patents that protect our inventions which are a result of a dedication to research, innovation, development, and design. Learn more at: woodmizer.com/patents

©2024 Wood-Mizer LLC

Printed in the United States of America, all rights reserved. No part of this manual may be reproduced in any form by any photographic, electronic, mechanical or other means or used in any information storage and retrieval system without written permission from

Wood-Mizer, LLC
8180 West 10th Street
Indianapolis, Indiana 46214

Table of Contents

Section-Page

SECTION 1 LASER INSTALLATION

1.1	Laser Installation.....	1-1
-----	-------------------------	-----

SECTION 2 OPERATION & ALIGNMENT

2.1	Laser Operation.....	2-1
2.2	Laser Alignment.....	2-1

SECTION 3 REPLACEMENT PARTS

3.1	Laser Assembly.....	3-1
-----	---------------------	-----

SECTION 1 LASER INSTALLATION

Before installing the laser option, be aware that the laser beam can not be seen in direct sunlight. The laser option is best for indoor cutting applications.

1.1 Laser Installation

1. Remove the two lower slide pad mounting nuts (inside of mast post).
2. Install the two lower holes of the laser assembly to the slide pad mounting bolts as shown.
3. Use the provided 5/16" flat washers and 5/16-18 nylon locking jam nuts to secure in place.
4. Use the two upper holes of the laser assembly bracket as a template and drill two 17/64" holes through the slide pad bracket.
5. Install the provided 5/16" self-tapping screws, lock washers and flat washers.
6. Install the point tip ground screw to either one of the small holes in the laser assembly mounting brackets.
7. Turn the screw in far enough so that it contacts the slide pad bracket.

IMPORTANT! Contact with the sawmill slide pad bracket is necessary to provide proper grounding for the laser. If proper contact is not made, the laser will not operate.

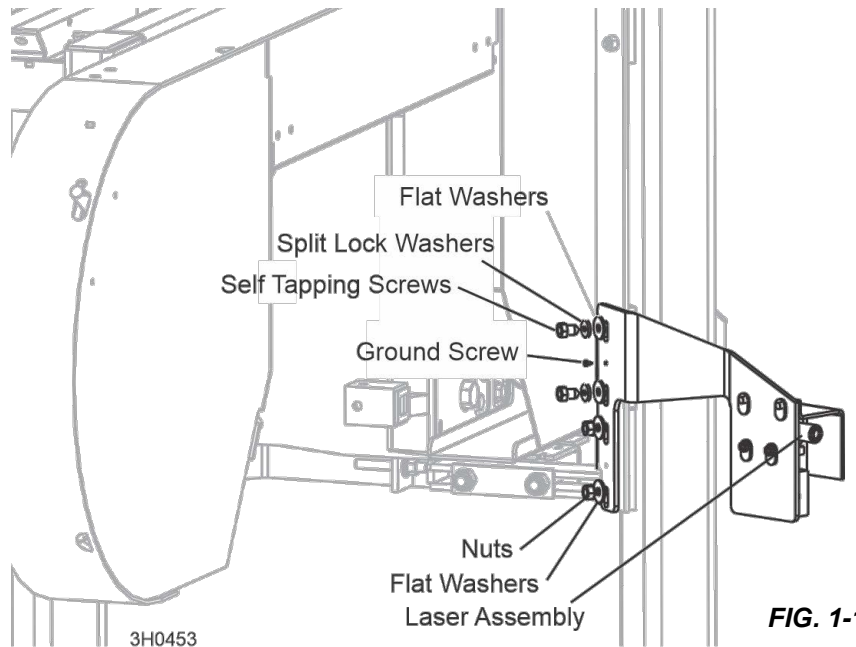

FIG. 1-1

8. Remove the drive belt guard.
9. Route the cable from the laser assembly:
 - a. Install one of the provided hose clamps to the laser assembly wire.
 - b. Remove the third slide pad nut from the bottom, install the hose clamp as shown and reinstall the slide pad nut.
 - c. Continue to route the wire downward, through the sawmill v-brace.
 - d. Route the wire upward, along the side mounting plate.

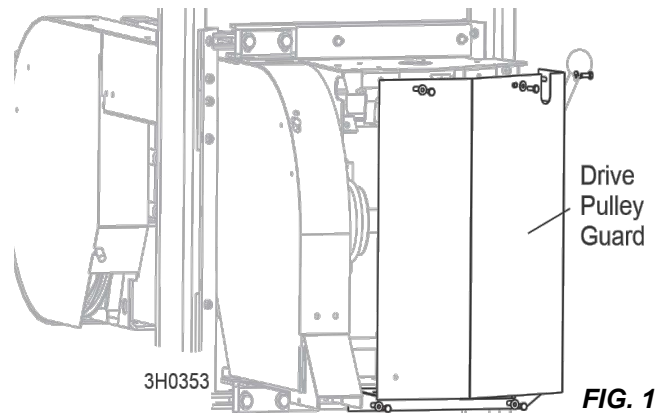

FIG. 1-2

- e. Secure with a wire tie to the outside of the side mounting plate brace.
- f. Continue to route the wire upward and secure with a wire tie to the fuel line EMT clamp.
- g. **Pre-92 mills:**
 - 1). Use the provided T-tap to connect to the red 16-gauge wire which leads from the circuit breaker on the key switch ACC post to the ON light.
 - 2). Install the T-tap by crimping the supplied blue T-tap terminal around the existing red 16-gauge wire.
 - 3). Make sure the new red laser assembly wire is routed correctly.
 - 4). Plug the quick connect into the T-tap terminal.
- e. **92 through 96 G18 Onan, G24, D40 mills:**

- 1). Use the provided T-tap to connect to the black 16 gauge Ignition wire as it exits from the upper harness conduit.
- 2). Install the T-tap by crimping the supplied blue T-tap terminal around the existing red 16-gauge wire.
- 3). Make sure the new red laser assembly wire is routed correctly.
- 4). Plug the quick connect into the T-tap terminal.

e. 92 through 96 G18 Briggs mills:

- 1). Install the provided wire assembly through the upper harness conduit and connect it to the key switch ACC post.
- 2). Connect the laser assembly wire to the end of the installed wire just installed.

c. 92 through 96 E15, E25 mills:

- 1). Use the provided T-tap to connect to the Ignition wire as it exits from the upper harness conduit. (The ignition wire is one of the three blue wires that continues on to the Y-Delta starter enclosure.)
- 2). Use a test light or a volt-ohm meter to identify.
- 3). Install the T-tap by crimping the supplied blue T-tap terminal around the existing red 16-gauge wire.
- 4). Make sure the new red laser assembly wire is routed correctly.
- 5). Plug the quick connect into the T-tap terminal.

10. Reinstall the drive belt guard, keeping the lower part of the laser assembly wire outside the guard as shown in FIG. 1-3.
11. Make sure the wire routes inside the guard at the lower right hand corner.
12. Install the provided two EMT clamps to the section of laser assembly wire which routes along the side mounting plate (underneath the pulley guard).
13. Use the guard's mounting washers and bolts to secure the EMT clamps in place as shown.

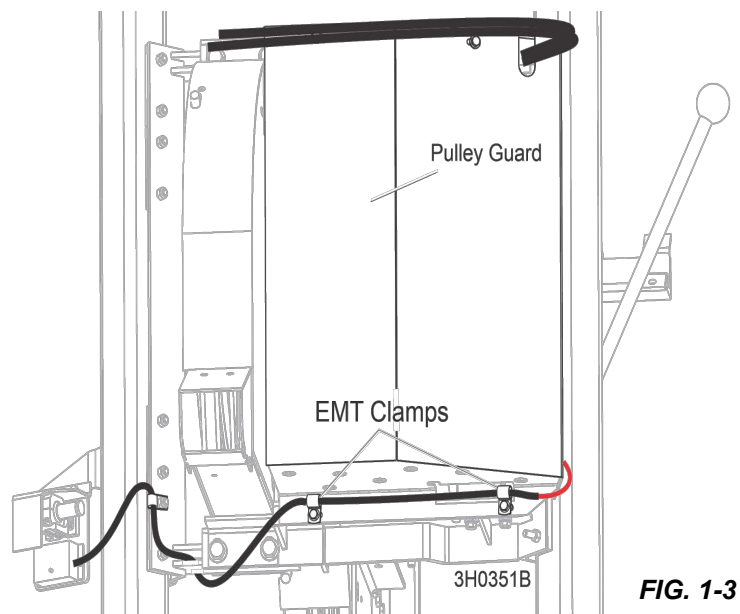

FIG. 1-3

SECTION 2 OPERATION & ALIGNMENT

2.1 Laser Operation

When properly installed, the laser option will guide you in making cuts.

To turn on the laser, turn the key switch to the ON (I) position.

To turn off the laser, turn the key switch to the OFF (O) position.

2.2 Laser Alignment

1. All sawmills must be setup on firm, level ground before proceeding with alignment.
2. Shim the feet of stationary sawmills so the weight of the sawmill is evenly supported.
3. Portable sawmills:
 - a. **LT30/LT30HD:** Adjust the two middle outriggers on the main frame tube down just enough to lift weight from the trailer tire.
 - b. **LT40/LT40HD:** Adjust the two end outriggers on the main frame tube down just enough to lift weight from the trailer tire.
 - c. **All Portable Sawmills:** Adjust the two outer outriggers down just so they touch the ground but do not bear weight.
4. Make sure the sawmill is properly aligned (see the Alignment Section of your Sawmill Operator's Manual.)
5. Load a cant onto the bed of the sawmill.
6. Make a cut.
7. Without raising the carriage head, return it to the front of the sawmill so that blade remains level with the top of the cant and the carriage head is 1' behind the front of the cant.
8. Align the laser.

When the laser is properly aligned, approximately 10" of beam will show across the front of the cant.

- a. Loosen the assembly mounting fasteners and laser assembly grounding screw to adjust the laser vertically.
- b. Move the entire laser assembly up or down as necessary.
- c. Retighten the fasteners to secure the assembly in position.
- d. Retighten the grounding screw to ensure laser operation.

NOTICE The laser cannot operate without proper grounding.

- e. To fine tune vertical alignment, the laser diode mounting bracket may be moved up or down as necessary.
- f. Retighten the diode mounting screws to secure the laser in place if any adjustments are made.

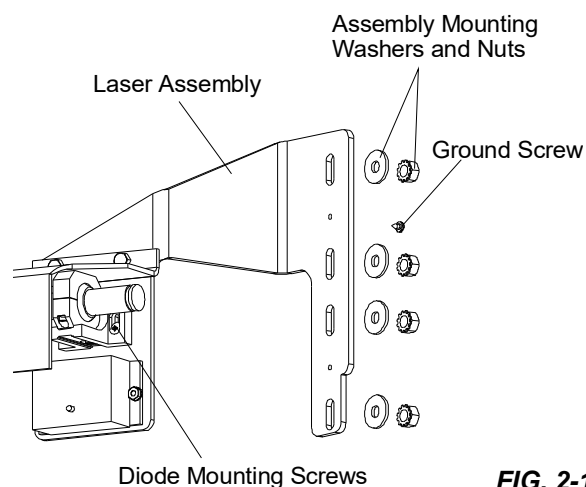

FIG. 2-1

If the laser beam is adjusted too high, it will not show against the side of the cant.

- g. Place an object on top of the cant so that the laser will be visible above the cant. (Folded paper is used in the example in FIG. 2-2.)
 - h. Turn on the laser.
 - i. Use steps **a** through **f** to adjust the bracket up or down so that the laser is at the correct height.
9. Adjust the laser horizontally.
- a. Loosen the laser pivot screws.
 - b. Pivot the laser diode side to side, or up and down, as necessary.
 - c. Retighten the pivot screws to secure the diode in place.

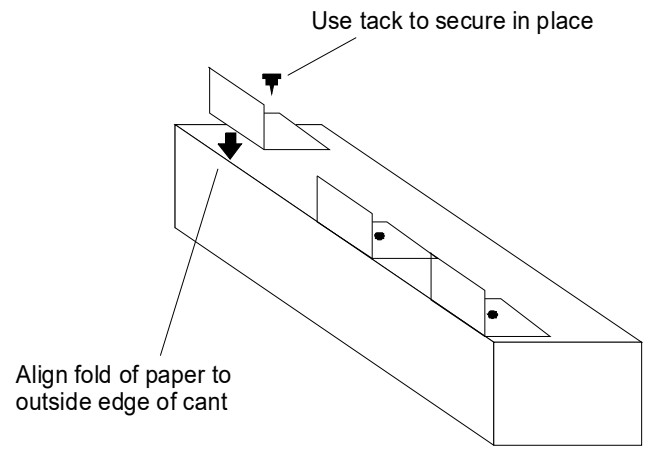
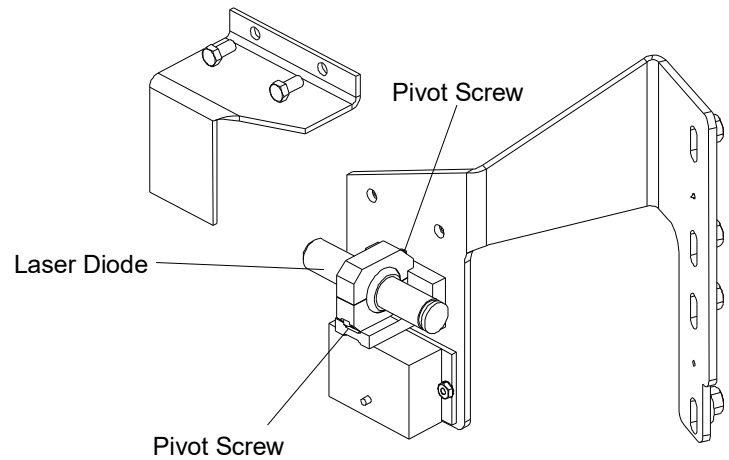

FIG. 2-2



3H0360B

FIG. 2-3

SECTION 3 REPLACEMENT PARTS

3.1 Laser Assembly

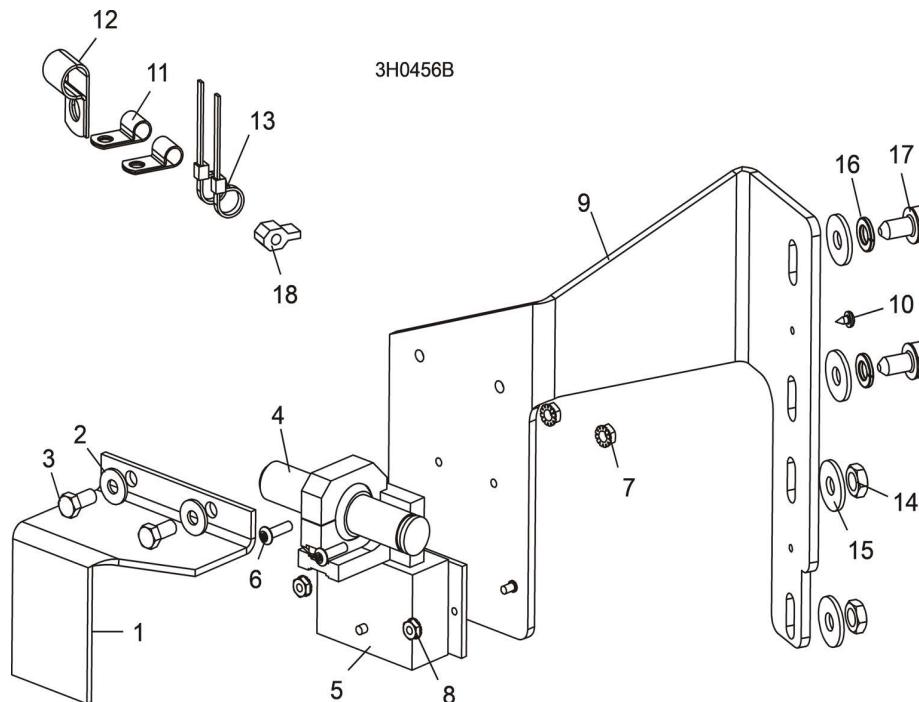

REF	PART #	DESCRIPTION	COMMENTS	QTY.
	024193-96	BRACKET ASSEMBLY, PRE-97 LASER	Available in assemblies only.	1
1	015508	Hood, Laser Bracket		1
2	F05011-11	Washer, 1/4" SAE Flat		2
3	F05005-15	Bolt, 1/4-20 X 1/2" Hex Head		2
	050500	Laser Kit, Replacement w/Power Supply	Replaces 024143 originally supplied before 2/02. Kit 050500 includes separate laser and power supply for easier replacement.	1
4	050367	Laser, 60deg Line w/Std Bkt & Connector		1
	045250	Bracket, Laser Mount (Plastic)		1
5	050368	Power Supply, Laser w/Connector		1
	F05089-1	Tie Wrap, 1/4" x 6"		2
	050500-1069	Instruction Sheet, Laser Replacement		1
6	F05004-98	Screw, #8-32 X 5/8" Socket Button Head Stainless Steel		2
7	F05010-41	Nut, #8-32 Self Locking		2
8	F05010-59	Nut, #6-32 Self Locking		2
9	015509	Bracket Weldment, Laser		1
10	F05015-4	Screw, #6 X 1/4" Philips Head Met		1
	052354	Fuse Holder, ATO Inline Self Tap	052354 Fuseholder replaces 024149 supplied prior to 5/05 (improved quality).	1
	024150-1	Fuse, 1A ATO Blade DK Grey		1
	024194-96	BAG ASSEMBLY, PRE-97 LASER PARTS		1

REF	PART #	DESCRIPTION	COMMENTS	QTY.
11	025671	Clamp, 1/4" Wire 9/32" Mounting Hole	Replaces 024148 1/8" Wire 9/32" Mounting Hole EMT Clamp (1/12).	2
12	024155	Clamp, 1/4" Wire 13/32" Mounting Hole EMT		1
13	F05089-1	Tie Wrap, 1/4" x 6"		2
14	F05010-121	Nut, 5/16-18 Nylon Lock Jam		2
15	F05011-16	Washer, 5/16" Standard Flat		4
16	F05011-13	Washer, 5/16" Split Lock		2
17	F05015-15	Screw, 5/16-24 X 5/8" Self Tapping		2
18	F04875-1	Connector, T-Tap 14-18AWG Female		1