

# FORM 361

## FINE ADJUST OUTRIGGER

### Part No. FAO

Enclosed parts include:

Item	Description	Part No.	Qty
1	Outrigger, Fine Adjust	FAO	1
2	Wrench, Adjustment	015763	1

### Installation and Operation

See **Figure 1**. Remove the existing, standard outrigger from the outrigger guide. Install the provided fine adjust outrigger (FAO) in its place.

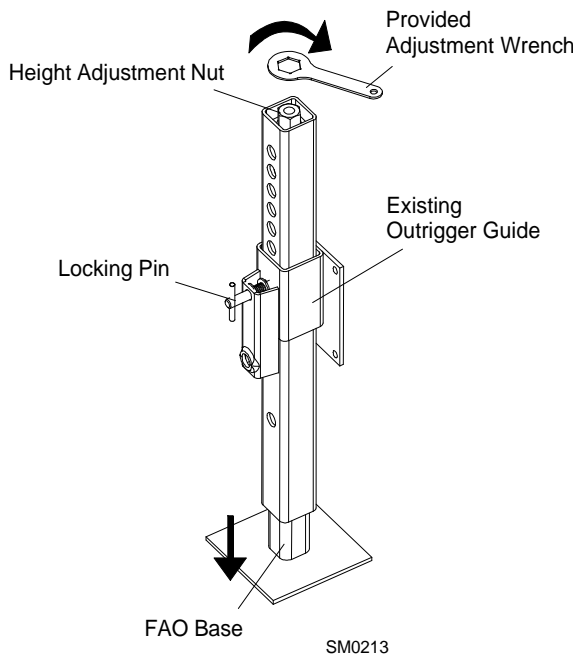

**FIGURE 1**

### Operation

Use of the FAO is similar to use of a standard outrigger. Refer to your Wood-Mizer Owner's Manual for normal setup and operation procedures.



**WARNING!** Do not set up the mill on ground with more than a 10 degree incline. If setup on an incline is necessary, put blocks under one side of the mill or dig out areas for outrigger legs to keep mill level. Setting up the mill on an incline could cause it to tip over, resulting in serious personal injury.

**WARNING!** Chock the trailer wheels to prevent movement before unhitching it from the towing vehicle. Failure to do so may result in serious injury or death.

**WARNING!** Always make sure the trailer is supporting the sawmill frame when operating a sawmill with adjustable outriggers. Failure to do so may result in serious injury or death. The adjustable outriggers are intended to support the saw frame with assistance from the trailer.

1. Unhitch the mill from the vehicle.
2. Lower and set the front three outriggers.

**See Figure 2.** Lift the weight from the locking pin using the jack handle. Pull the locking pin to release the outrigger and lower the outrigger as necessary. Secure with the locking pin.

For FAO(s), lower the outrigger as close to the ground as possible, then secure in place with the locking pin. Adjust the outrigger base so that it contacts the ground. To adjust, use the provided wrench to turn the height adjustment nut. Turn clockwise to lower. Turn counterclockwise to raise. Maximum adjustment available is 1 1/2" (3.8 cm).



**CAUTION!** Do not adjust the FAO outrigger base height while there is weight on the FAO. Damage to the FAO may result.

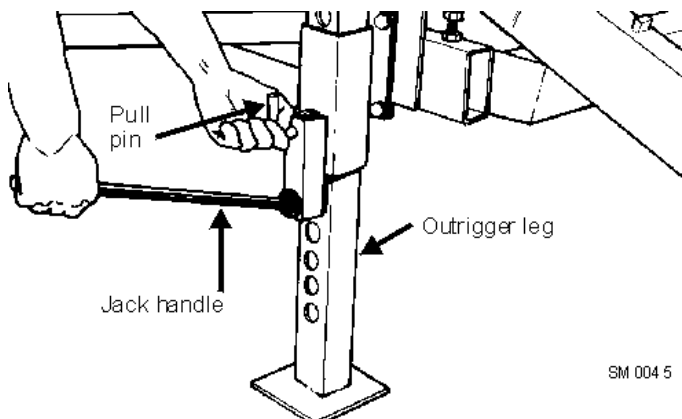

**FIGURE 2**

3. Unhook the carriage safety chain, located at the bottom of the vertical mast.
4. Raise the cutting head from the carriage rest pin. Swing the rest pin down below bed level.



**WARNING!** Failure to put front outrigger down before moving cutting head from the rest position may result in serious injury.

5. Move the cutting head toward the front end of the mill. Lower and set the remaining rear outriggers.
6. Level the sawmill by adjusting the outriggers to raise or lower each end of the sawmill. Adjust all outriggers evenly to avoid twisting the mill frame by jacking one outrigger higher than the others.

For FAO(s), fine tune the outrigger base height as necessary. Move the cutting head to the opposite end of the mill from the outrigger. Raise the entire outrigger (to remove the sawmill weight from it) and adjust the outrigger base as necessary. Lower the entire outrigger and use the locking pin to secure in position.



**CAUTION!** Do not adjust the FAO outrigger base height while there is weight on the FAO. Damage to the FAO may result.

## Maintenance

Grease the FAO every 200 hours of operation or once a month, whichever comes first. Use one squeeze of a NLGI No. 2 grade lithium grease from a grease gun to lubricate the outrigger and remove any sawdust.

**See Figure 3.** To access the outrigger grease fitting, raise the outrigger base all the way. The grease fitting will be accessible through the lowest outrigger hole.

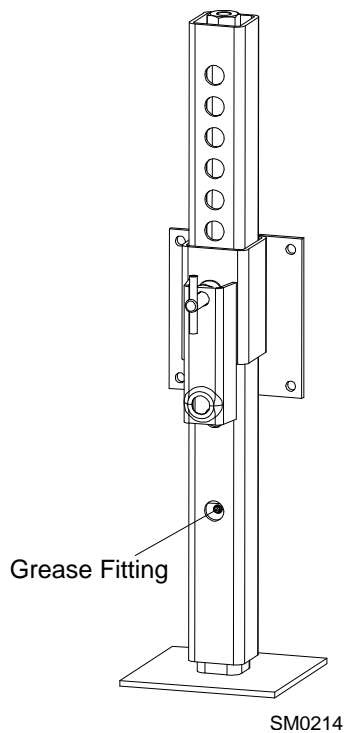

**FIGURE 3**

## Towing with the FAO

**See Figure 4.** Make sure the outrigger base is adjusted so the grease fitting is just below the lowest outrigger hole before securing the FAO in position with the lock pin. This provides maximum ground clearance while preventing the lock pin from hitting the grease fitting.



**CAUTION!** Be sure the outrigger base is adjusted properly before securing the FAO in position with the lock pin. Failure to do so will cause damage to the outrigger grease fitting.



**CAUTION!** Do not adjust the FAO outrigger base height while there is weight on the FAO. Damage to the FAO may result.

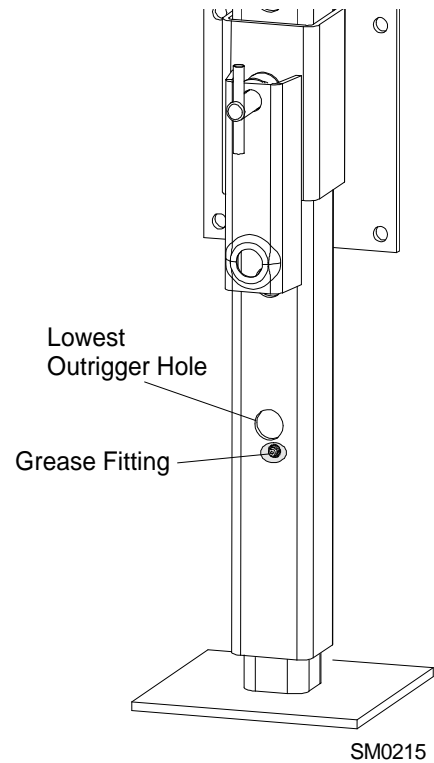

**FIGURE 4**