



Debarker Option

Safety, Installation, Operation, Maintenance & Parts Manual

MKII for Pre-97 Sawmills rev. A.00 - C.06



Safety is our #1 concern! Read and understand all safety information and instructions before operating, setting up or maintaining this machine.

April 1998

Form #675

Table of Contents	Section-Page
SECTION 1 SAFETY	1-1
1.1 Installation and Maintenance.....	1-1
1.2 Operation and Towing.....	1-2
SECTION 2 DEBARKER INSTALLATION	2-1
2.1 Debarker Frame Mounting Holes.....	2-2
2.2 Debarker Control Mounting Holes.....	2-3
2.3 Debarker Control Installation.....	2-4
2.4 Debarker Installation.....	2-6
2.5 Lower Harness Installation.....	2-1
2.6 Upper Harness Installation.....	2-7
SECTION 3 ALIGNMENT	3-1
SECTION 4 OPERATION AND MAINTENANCE	4-1
4.1 Locking Pin Operation.....	4-1
4.2 Control Overview.....	4-3
4.3 Operation.....	4-5
4.4 Maintenance.....	4-7
4.5 Troubleshooting.....	4-10
SECTION 5 ELECTRICAL INFORMATION	5-1
5.1 Electrical Symbol Diagram.....	5-1
5.2 Electrical Component List.....	5-2
SECTION 6 DEBARKER PARTS	6-1
6.1 Mechanical Assembly.....	6-1
6.2 Frame Assembly.....	6-2
6.3 Mount/Lock Pin Assembly.....	6-4
6.4 In/Out Motor Drive Assembly.....	6-5
6.5 Blade Motor Assembly.....	6-7
<i>Rev. C.05+</i>	
6.6 Blade Motor Assembly.....	6-9
<i>Rev. A.00 - C.04</i>	
6.7 Blade Housing Assembly.....	6-11
<i>Rev. C.00+</i>	
6.8 Blade Housing Assembly.....	6-13
<i>Rev. A.00 - B.00</i>	
6.9 Spring Rod Assembly.....	6-15
6.10 Debarker Control Box Assembly.....	6-16
INDEX	1-I

SECTION 1 SAFETY



This symbol calls your attention to instructions concerning your personal safety. Be sure to observe and follow these instructions. This symbol accompanies a signal word. The word **DANGER** indicates an imminently hazardous situation which, if not avoided, will result in death or serious injury. **WARNING** suggests a potentially hazardous situation which, if not avoided, could result in death or serious injury. **CAUTION** refers to potentially hazardous situations which, if not avoided, may result in minor or moderate injury to persons or equipment. Read all safety instructions before operating this equipment and observe all safety warnings!

1.1 Installation and Maintenance



DANGER! On electric mills, hazardous voltage inside the disconnect box, starter box, and at the electric motor can cause shock, burns, or death. Disconnect and lock out power supply before performing debarker installation! Follow all applicable electrical codes.

DANGER! Make sure all electrical installation, service and/or maintenance work is performed by a qualified electrician and is in accordance with applicable electrical codes. Failure to do so will result in serious injury or death.

DANGER! Before performing any service to this equipment, turn the key to the OFF position, remove the key, and disconnect the sawmill battery ground terminal. Failure to do so will result in serious injury or death.



WARNING! Before replacing the debarker blade, move the sawmill blade guide arm in front of the sawmill blade to cover the blade teeth. Failure to do so may result in serious injury or death.

1.2 Operation and Towing



DANGER! Make sure all guards and covers are in place and secured before operating the debarker option. Failure to do so may result in serious injury.

DANGER! Keep all persons out of the path of moving equipment when operating the debarker. Failure to do so will result in serious injury.

DANGER! Always remove the key from the control panel before preparing the debarker for towing. Failure to do so may result in serious injury.



WARNING! Debarker is ON when warning light (or bell sounds prior to Rev. C.05). DO NOT disconnect the warning light (or bell). Doing so may result in serious injury.

WARNING! If the debarker continues to run with the key switch in the OFF position, remove the negative battery terminal from the battery post.

DO NOT continue to operate the mill if the main key switch does not control debarker operation. Doing so could result in serious injury. Call Wood-Mizer customer service for more information.

SECTION 2 DEBARKER INSTALLATION

 **DANGER!** On electric mills, hazardous voltage inside the disconnect box, starter box, and at the electric motor can cause shock, burns, or death. Disconnect and lock out power supply before performing debarker installation! Follow all applicable electrical codes.

DANGER! Before performing any service to this equipment, turn the key to the OFF (0) position, remove the key, and disconnect the sawmill battery ground terminal. Failure to do so will result in serious injury or death.

 **CAUTION!** Due to various design changes and past retrofits and options, you should very carefully look your mill over to determine Debarker compatibility before beginning Debarker installation.

The Debarker Option may be installed to most sawmills with the required up/down chains and 60 amp or larger alternator systems.

See Table 2-1. Look at your sawmill up/down chains to verify they are the proper style for use with the Debarker Option. Refer to the chart below to determine if the Debarker Option may be installed on your specific sawmill.

Up/Down Chain Type	Install Debarker?	Comments
Single #40	No	The Debarker Option can only be installed on sawmills equipped with dual up/down chains (after 7/86).
Dual #40	Yes, if USA chain. See comments.	"USA" should be stamped into the side plates of the chain. If it is not, you will need to replace the existing chains with the proper specified chains. If you did not receive replacement chains with your Debarker order and find that you need them, call Wood-Mizer Customer Service at 1-800-525-8100 . Do not proceed with Debarker installation or further operation until your mill is equipped with the correct up/down chains.
#50-2	Yes	The Debarker Option can be installed on any sawmill equipped with #50-2 up/down chain (after 3/97).

TABLE 2-1

2.1 Debarker Frame Mounting Holes

IMPORTANT! Later sawmills are equipped with pre-drilled Debarker mounting holes. **Verify hole locations before beginning Debarker installation. Proper hole location is imperative for safe and effective Debarker operation.**

Six holes in the sawmill saw head are required to mount the debarker.

See Figure 2-1. If your sawmill has no pre-drilled holes, use the provided template as a guide to drill the required holes.

1. Locate the template against the top of the c-frame. Move the harness and water lube hose out of the way and locate the template against the side of the c-frame. Locate the bent tab against the c-frame vertical tube. Clamp the template in place to secure it.

Use a 13/32" drill to start holes at locations A and B. Remove the template and drill holes through completely.

Secure template to top and side of horizontal saw head tube

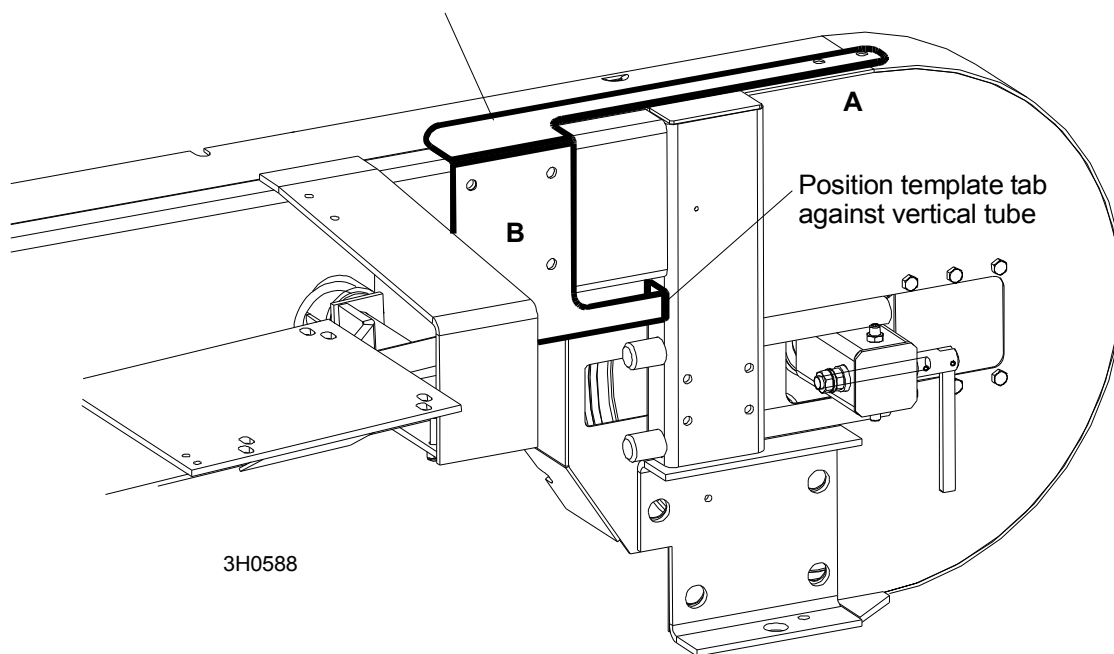

FIG. 2-1. CLAMP DRILL TEMPLATE IN PLACE.

2.2 Debarker Control Mounting Holes

See **Figure 2-2**. The model and age of your sawmill will determine where you need to install the debarker control. If you have a standard mill manufactured after June 1996, or any super series mill, use the location D on the motor support tube shown in the main portion of the figure. If you have a standard mill manufactured during or prior to June 1996, use the alternate location D on the motor mount plate shown in the figure inset. Drill two 9/32" diameter holes at the locations shown.

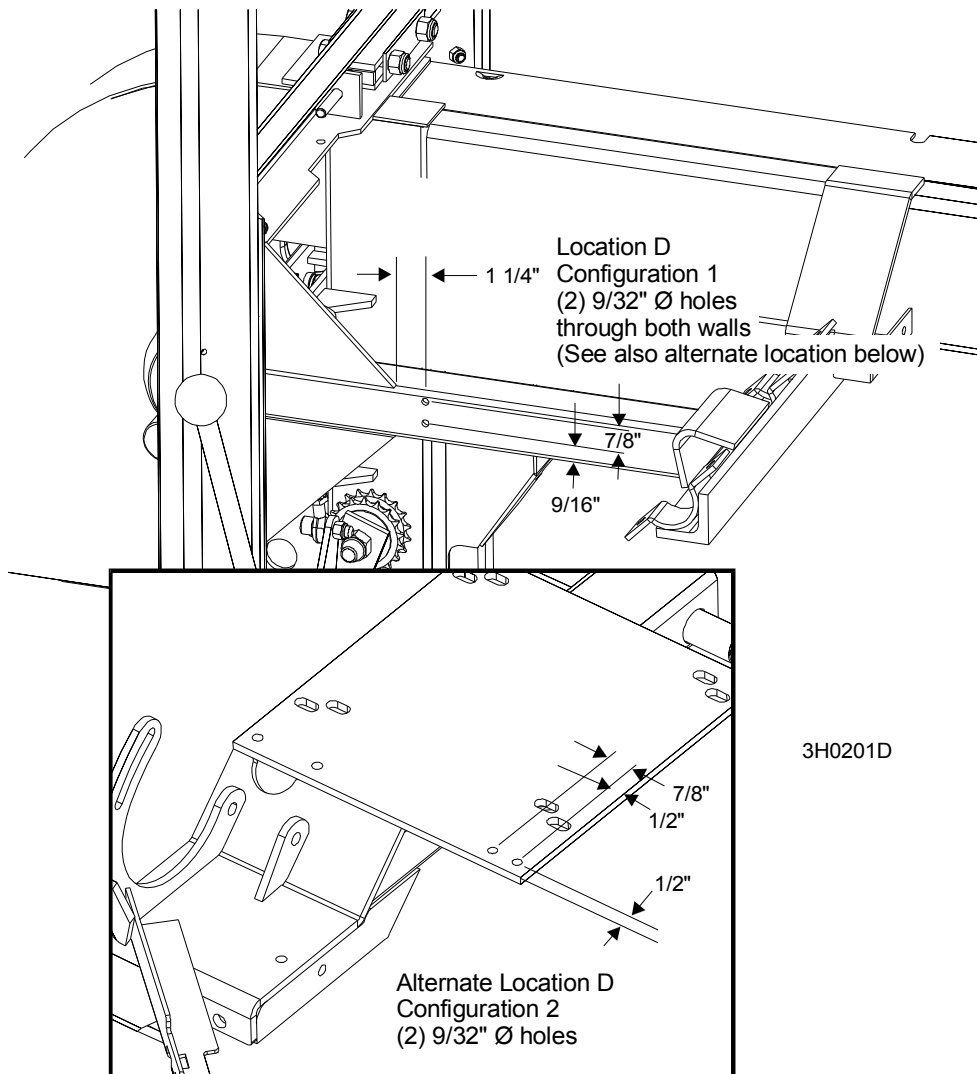

FIG. 2-2

2.3 Debarker Control Installation

NOTE: Loose installation hardware is located in the bag assembly.

1. Assemble the control box to location D (or alternate location D, as determined by mill type).
2. If you have a standard sawmill manufactured **after** LT30 rev. F6, LT40 rev. F7, or LT30HD/40HD rev. F9, or if you have any revision super series sawmill:

See Figure 2-3. Install the mounting bracket as shown and use the four 1/4-20 x 3/8" socket button head screws to secure the bracket to the control box. Use the provided 1/4-20 x 2 3/4" hex head grade 2 bolts and 1/4-20 hex lock nuts to secure the box assembly to the mill.

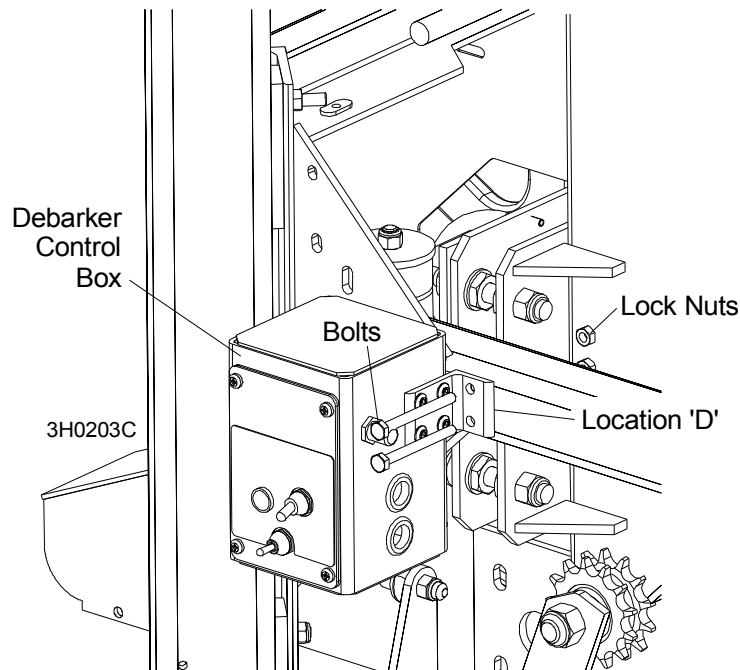

FIG. 2-3

If you have a standard sawmill manufactured *prior* to LT30 rev. F6, LT40 rev. F7, or LT30HD/40HD rev. F9:

See **Figure 2-4**. Install the four 1/4" SAE flat washers and vibration isolators to the control box and tighten by hand. **NOTE:** Install and tighten one isolator at a time, placing the 1" isolators diagonal to each other and the 3/4" isolators diagonal to each other.



DANGER! To prevent possible damage or injury, be sure the enclosed vibration isolators are installed to the Debarker control box before Debarker use on any of the mill revisions listed below.

Position the mounting bracket as shown and use four 1/4-20 self locking nuts to secure the bracket to the control box.

Use the provided 1/4-20 x 1" hex head grade 2 bolts and 1/4-20 hex lock nuts to secure the box assembly to the mill.

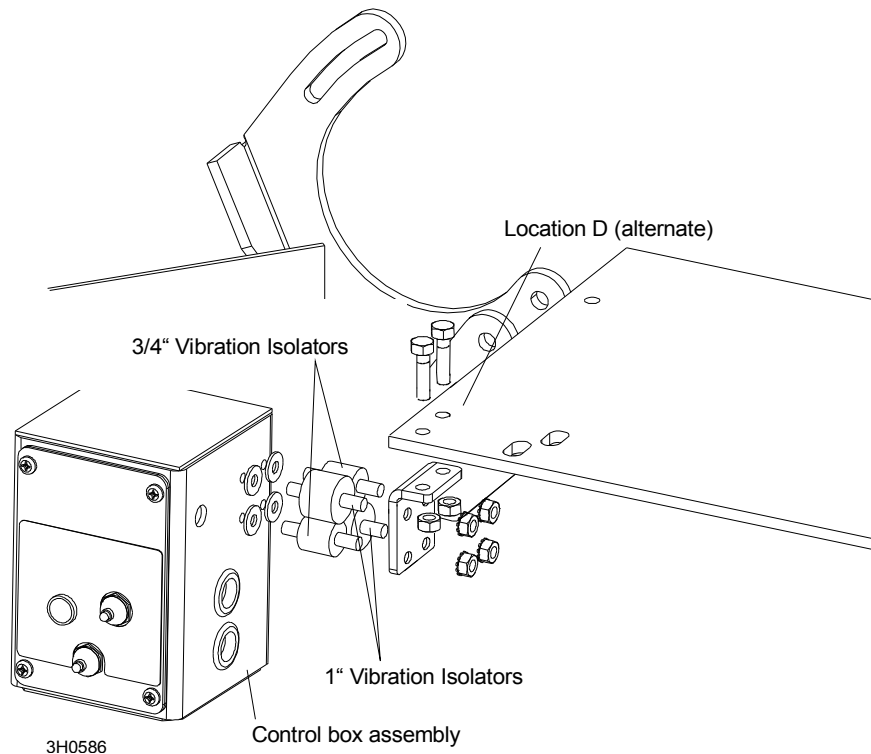

FIG. 2-4

2.4 Debarker Installation

NOTE: You will not use all components of the debarker bag assembly during installation. Excess hardware is included to cover all possible mill variations and needs.

1. Open the middle blade housing cover. Remove the four pre-installed bolts and nuts from the debarker frame mounting blocks.
2. Assemble the debarker to the sawmill saw head. Align the mounting block holes and the holes in the saw head. Insert the bolts from the back of the saw head, through the debarker mounting block holes. Use the lock nuts to secure in place. Tighten the mounting bolts to 20 ft.-lbs. torque. Do not tighten the set screws in the mounting blocks until debarker alignment has been performed.

NOTE: When installing, make sure the blade guide motor wire harness is routed between the saw head and the pivot arm.

See Figure 2-5.

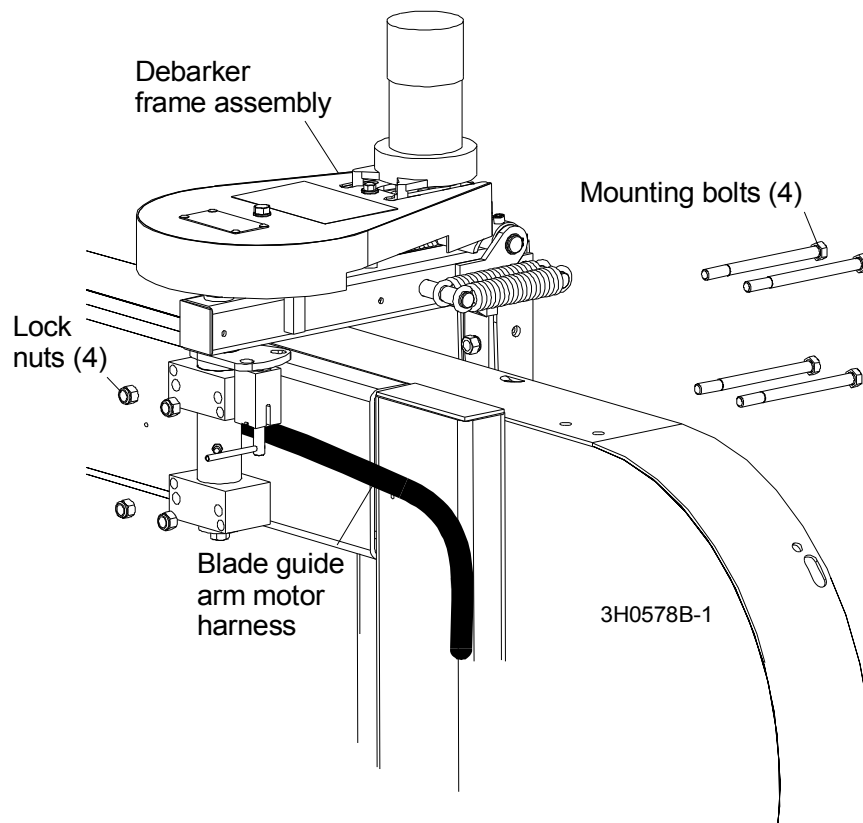

FIG. 2-5

3. Assemble the debarker cutting head to the mount plate on the frame.

Use the four provided 5/16-18 x 3/4" bolts and 5/16" split lock washers to mount the cutting head to the debarker frame. Use the lower set of four holes in the head mounting plate. The upper set of holes are provided in the event the cutting head needs to be adjusted further down than the slotted motor mount holes will allow.

See Figure 2-6.

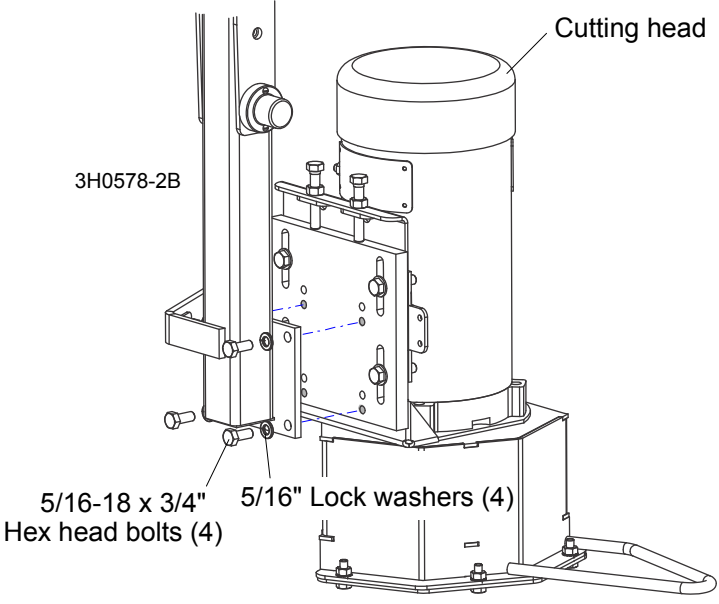

FIG. 2-6

2

Debarker Installation

Debarker Installation

4. Install the spring arm assembly to the debarker in/out pulley using the 3/8-16 x 1 3/4" hex head bolt, two flat washers, and two lock nuts provided.
5. Remove the idle-side blade housing cover. Align the two holes in the spring arm bracket with the two holes in the top of the saw head blade housing. Use the provided 3/8-16 x 1" hex head bolts and 3/8-16 nylon lock nuts to secure the spring arm bracket saw head. Replace the blade housing cover. Close the middle blade housing cover.

See Figure 2-7.

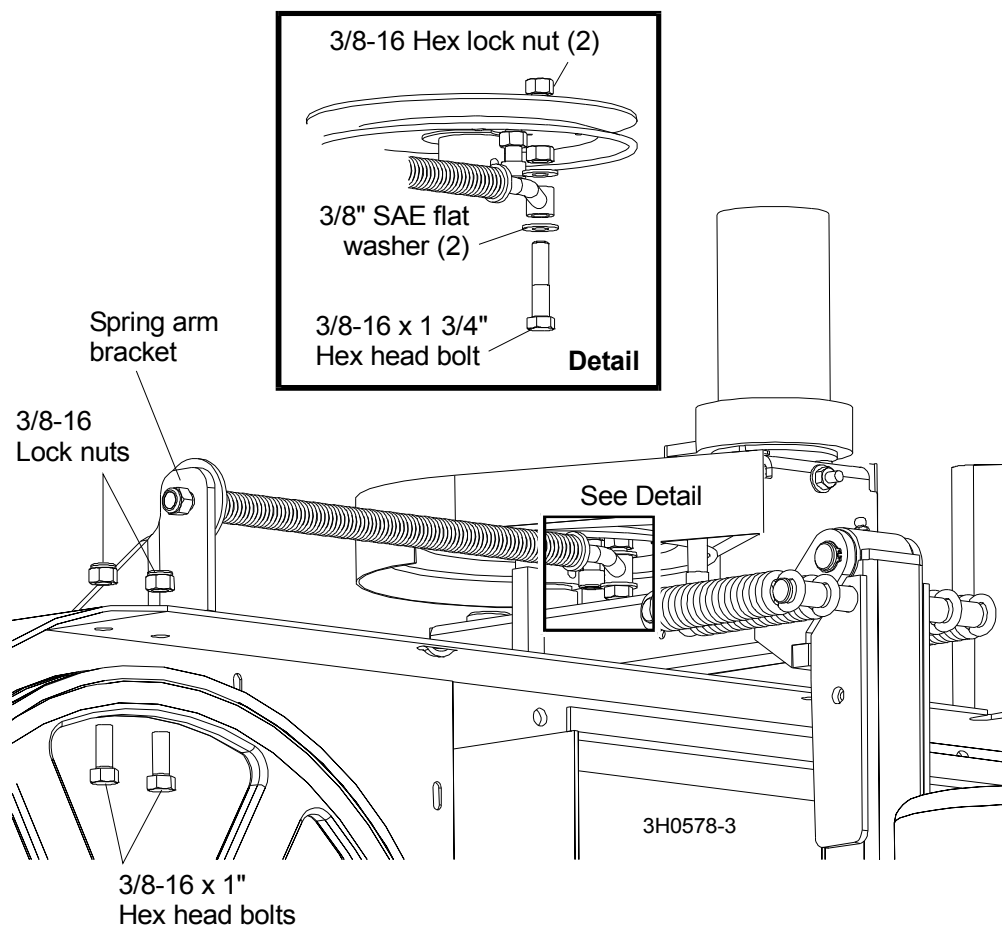

FIG. 2-7

- 6. Install the blade guard bracket and flexible debris guard to the debarker head with two 1/4" flat washers, lock washers, and 1/4-20 x 1" hex head bolts. Be sure the bottom of the debris guard is even with the bottom of the debarker blade.

See Figure 2-8.

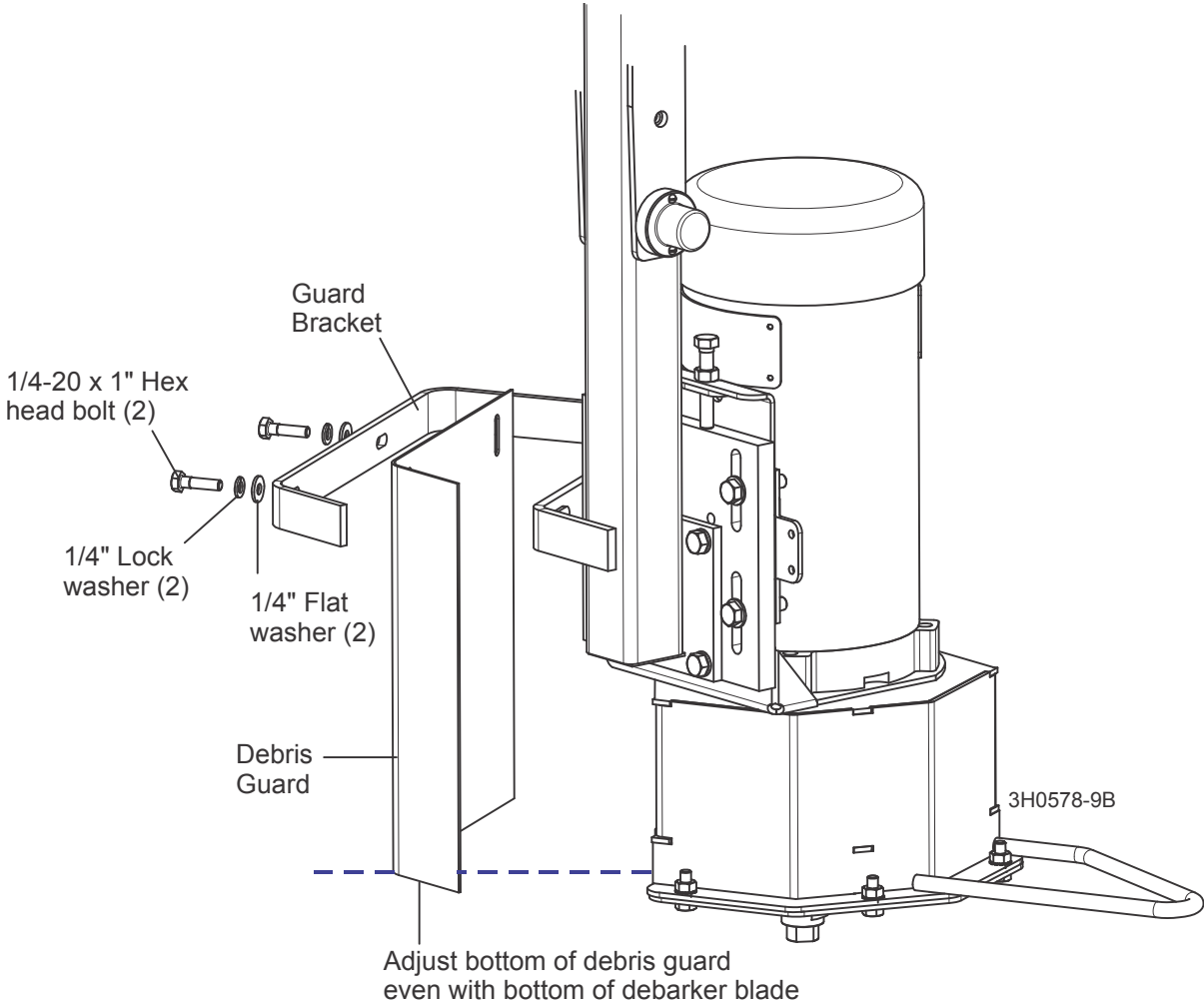

FIG. 2-8

2.5 Lower Harness Installation



DANGER! On electric mills, hazardous voltage inside the disconnect box, starter box, and at the electric motor can cause shock, burns, or death. Disconnect and lock out power! Follow all applicable electrical codes.

DANGER! Before performing any service to this equipment, turn the key to the OFF (0) position, remove the key, and disconnect the sawmill battery ground terminal. Failure to do so will result in serious injury or death.



IMPORTANT! Avoid pinch and pivot points, unnecessary wire bending and open spaces where the wire could get caught by a log, etc. If you have any questions, call Wood-Mizer customer service.

1. Locate the lower motor harness on the debarker control box. Route the lower harness under and around the sawmill motor mount using provided clamps and 1/4-20 x 1" hex head grade 2 bolts as needed.
2. Route the harness between the debarker mount and saw head as shown. Continue routing the harness along the debarker frame, under the spring arm and down toward the blade motor.

See Figure 2-9.

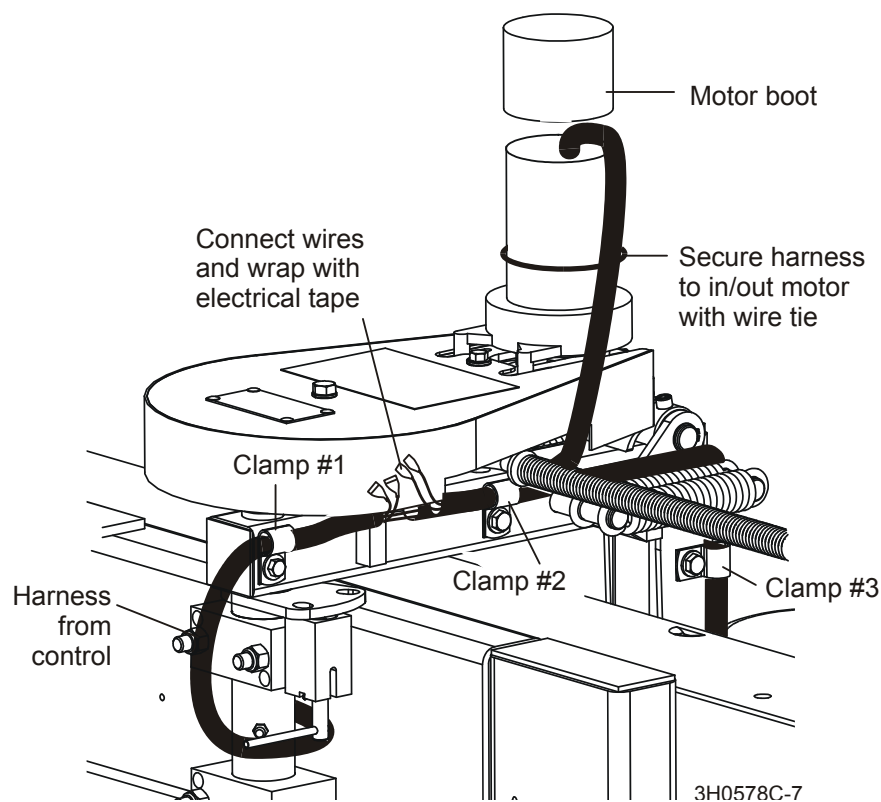

FIG. 2-9

3. Secure the harness to the debarker frame using three harness clamps, 1/4" flat washers and 1/4-20 x 1/2" hex head bolts. Be sure to leave enough slack in the harness to allow the debarker its full range of movement and also to prevent undue wire stress from sharply bent wires.
4. Remove the boot from the in/out motor. Install the short piece of conduit over the red and black in/out motor wires.
5. Route the cable underneath the spring arm, through harness clamp #2.

2

Debarker Installation

Lower Harness Installation

6. Replace the in/out motor boot and use one of the provided wire ties to secure the harness to the side of the drive motor.
7. Strip the end of the black in/out motor wire and install a provided 1/4" male quick connect terminal. Cut the red in/out motor wire so it is 1" shorter than the black motor wire, strip the end, and install a provided 1/4" male quick connect terminal. This will allow the wires to be neatly bundled together and wrapped later.
8. Force a hole in the long harness conduit between clamps #1 and #2. Pull the small red wire #21 and small black wire #22 through the hole. Cut both wires if necessary so approximately 2" of wire protrudes from the harness.
9. Strip the ends of both wires and install a provided female quick connect terminal to each wire.
10. Connect the red in/out motor wire to the red control harness wire. Connect the black in/out motor wire to the black control harness wire. Wrap the wire connections with electrical tape.
11. Route the harness and wires from the warning light (or bell prior to Rev. C.05) to the terminal posts on the blade motor.

12. Rev. C.05+: Secure the warning light wires to the motor harness with a wire tie approximately 3" from the motor terminals as shown.

See Figure 2-10.

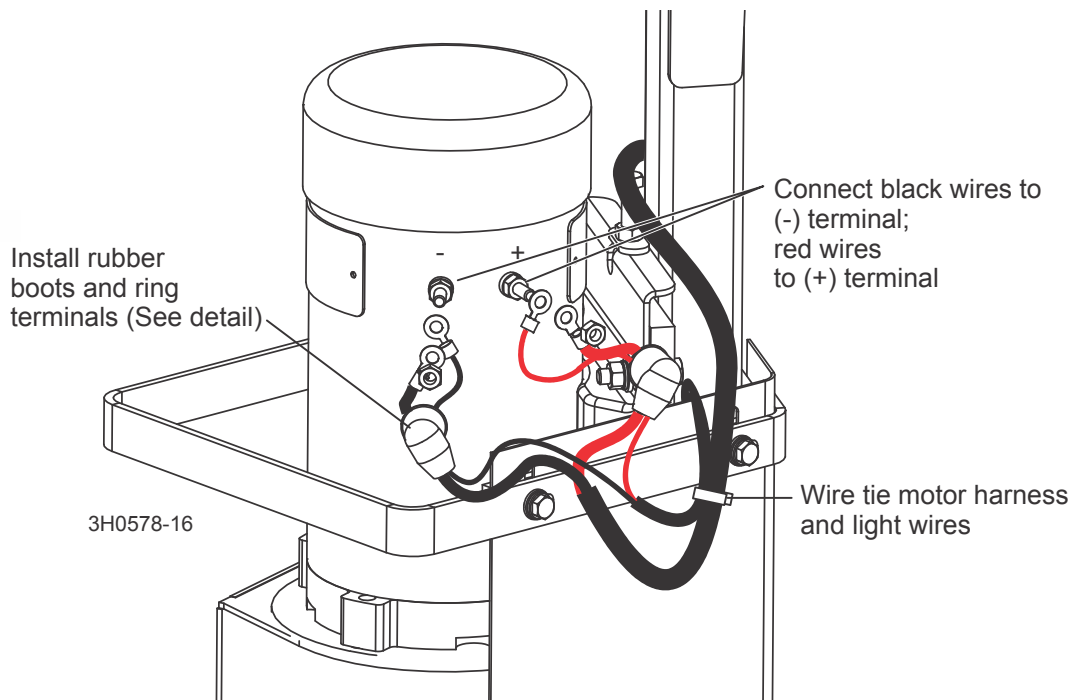

FIG. 2-10 REV. C.05+

2

Debarker Installation

Lower Harness Installation

- 13. Prior to Rev. C.05:** Secure the warning bell wires to the motor harness with a wire tie approximately 3" from the motor terminals as shown.

See Figure 2-11.

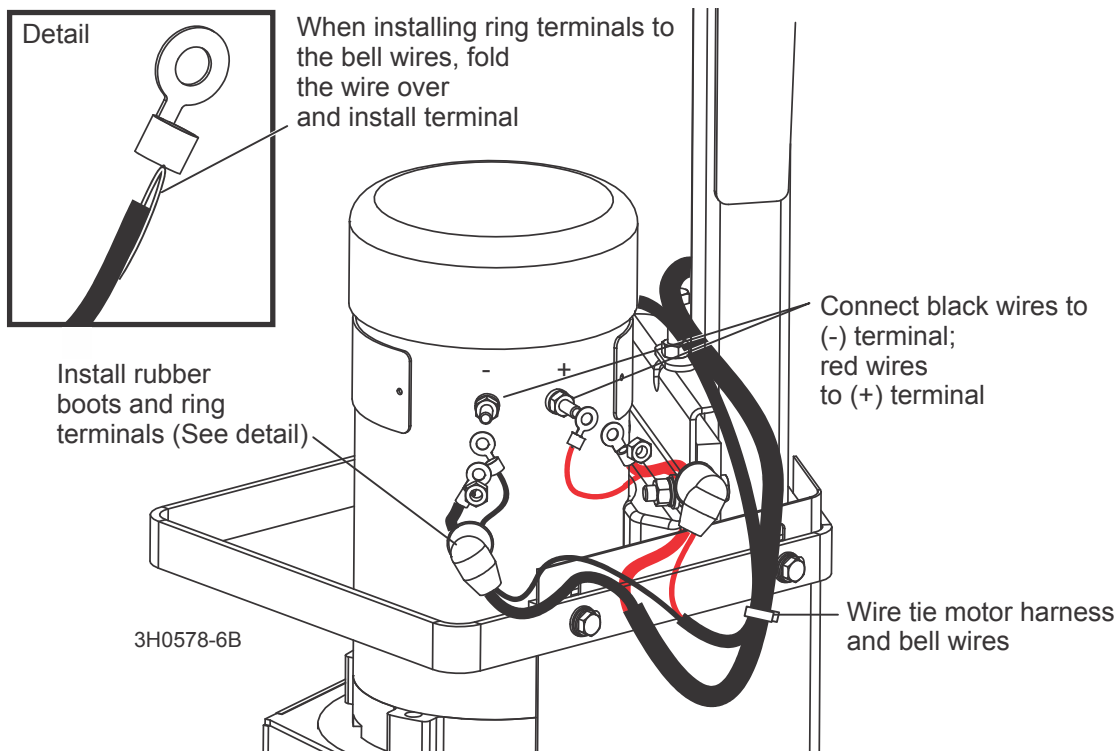

FIG. 2-11 PRIOR TO REV. C.05

- 14.** Remove the top nuts from each of the motor terminals. The harness conduit and wires may be longer than necessary (to allow for differences in routing).
- 15.** Route the black motor wire from the harness and the black wire from the warning light (or bell prior to **Rev. C.05**) through one of the provided rubber boots. **Prior to Rev. C.05:** Strip the end of the black motor wire and install a 1/4" 8 gauge ring terminal. Strip the end of the black warning bell wire and install a 1/4" 14-16 gauge ring terminal. To install the 14-16 gauge ring terminal, fold the stripped end of the wire over the insulation, install the ring terminal and crimp in place.
- 16.** Connect the black motor and light wires (or bell wires prior to **Rev. C.05**) to the negative (-) motor terminal. Replace the terminal nut to secure the wires.



IMPORTANT! Make sure that the ring terminals do not touch the motor body.

17. Route the red motor wire and the red wire from the warning light (or bell prior to **Rev. C.05**) through one of the provided rubber boots. **Prior to Rev. C.05:** Strip the end of the red motor wire and install a 1/4" 8 gauge ring terminal. Strip the end of the red warning bell wire and install a 1/4" 14-16 gauge ring terminal. To install the 14-16 gauge ring terminal, fold the stripped end of the wire over the insulation, install the ring terminal and crimp in place.
18. Connect the red motor and light wires (or bell wires prior to **Rev. C.05**) to the positive (+) motor terminal. Replace the terminal nut to secure the wires.



IMPORTANT! Make sure that the ring terminals do not touch the motor body.

19. Slide the rubber boots over the motor terminal posts to protect the connections.
20. Replace all removed covers and guards.

2.6 Upper Harness Installation



DANGER! On electric mills, hazardous voltage inside the disconnect box, starter box, and at the electric motor can cause shock, burns, or death. Disconnect and lock out power! Follow all applicable electrical codes.

DANGER! Before performing any service to this equipment, turn the key to the OFF position, remove the key, and disconnect the sawmill battery ground terminal. Failure to do so will result in serious injury or death.



IMPORTANT! Avoid pinch and pivot points, unnecessary wire bending and open spaces where the wire could get caught by a log, etc. If you have any questions, call Wood-Mizer customer service.

Find the upper power harness on the debarker control box. The upper power harness routing will differ from mill to mill.

G24HP/G35HP MILLS

1. Route the upper power harness with wire #203 and #210 from the debarker control box under and around the motor mount towards the alternator. While routing, use provided clamps/drill holes as necessary to secure the harness in place.
2. Use a provided wire tie to secure the harness tubing to the existing sawmill power feed control upper harness a few inches from where the sawmill control harness ends near the alternator. Cut excess tubing from the debarker power harness, leaving the wires long.
3. Route the red power wire #203 to the starter or alternator battery post, whichever you find easier to access. Cut excess wire as needed. Terminal connection size may vary. Use supplied ring terminals for wire connection as needed.



IMPORTANT! Make sure that the ring terminal does not touch the alternator/starter body.

4. Route the black power wire #210 to the engine ground. Cut excess wire as needed. Terminal connection size may vary. Use supplied ring terminals for wire connection as needed.

D40 MILLS

1. Route the upper power harness with wire #203 and #210 from the debarker control box under and around the motor mount towards the starter. While routing, use provided clamps/drill holes as necessary to secure the harness in place.
2. Use a provided wire tie to secure the harness tubing to the existing sawmill control harness a few inches from where the harness ends near the starter. Cut excess tubing from the debarker power harness, leaving the wires long.
3. Route the red power wire #203 to the starter battery post. Cut excess wire as needed. Use supplied ring terminal for wire connection as needed.



IMPORTANT! Make sure that the ring terminal does not touch the starter body.

4. Route the black power wire #210 to the engine ground. Cut excess wire as needed. Use supplied ring terminal for wire connection as needed.

E15HP/E20HP/E25HP MILLS



DANGER! On electric mills, hazardous voltage inside the disconnect box, starter box, and at the electric motor can cause shock, burns, or death. Disconnect and lock out power! Follow all applicable electrical codes.

1. Route the upper power harness with wire #203 and #210 from the debarker control box under and around the motor mount towards the alternator. While routing, use provided clamps/drill holes as necessary to secure the harness in place.
2. Use a provided wire tie to secure the harness tubing to the existing sawmill control harness a few inches from where the harness ends near the alternator. Cut excess tubing from the debarker power harness, leaving the wires long.
3. Route the red power wire #203 to the alternator battery post. Cut excess wire as needed. Use supplied ring terminal for wire connection as needed.



IMPORTANT! Make sure that the ring terminal does not touch the alternator body.

4. Route the black power wire #210 to the engine ground. Cut excess wire as needed. Use supplied ring terminal for wire connection as needed.

All Sawmills

2

Debarker Installation

Upper Harness Installation

5. Route the upper power harness with wire #200 and #205 from the debarker control box to the location where the upper sawmill control conduit terminates at or near the motor mount. Continue routing the debarker harness down the upper sawmill control conduit. Use provided wire ties to secure the debarker harness to the sawmill control conduit. Place the last wire tie approximately 12" from the sawmill control box.
6. Remove the rear panel assembly from the sawmill control box.

See Figure 2-12.

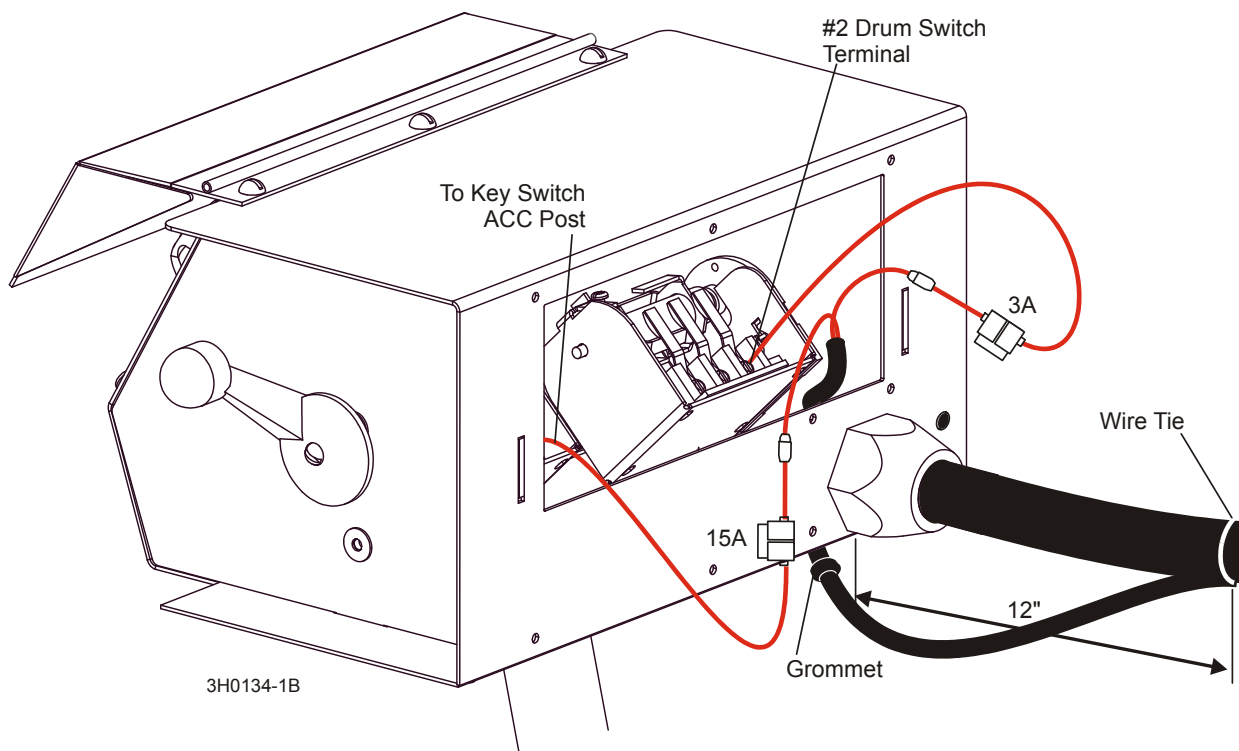

FIG. 2-12

7. Drill a 3/8" diameter hole in the floor of the control box near the upper control harness connector. Be careful while drilling not to damage wires or components in the control box. Deburr the hole to remove metal shavings that could damage the wiring.
8. Route the debarker harness through the control box hole and insert the pre-installed grommet into the hole.
9. Crimp a provided male quick connect terminal to the end of wire #200 and #205.

10. Locate the 3-amp fuse holder assembly and connect the female quick connect terminal to the male terminal on wire #200. Connect the fork terminal end of the fuse holder assembly to the #2 terminal on the power feed drum switch.
11. Locate the 15 amp fuse holder assembly and connect the female quick connect terminal to the male terminal on wire #205. Connect the ring terminal end of the fuse holder assembly to accessory (ACC) post on the key switch.
12. Reconnect the battery ground terminal.



WARNING! If the debarker continues to run with the key switch in the OFF position, remove the negative battery terminal from the battery post.

DO NOT continue to operate the mill if the main key switch does not control debarker operation. Call Wood-Mizer customer service for more information.

SECTION 3 ALIGNMENT



DANGER! Before performing any service to this equipment, turn the key to the OFF (0) position and remove the key. Failure to do so will result in serious injury or death.

The debarker blade should be aligned to the sawmill blade to insure proper operation. The debarker blade should be parallel with and aligned vertically with the sawmill blade.

1. Turn the key to ACC (3) and use the debarker in/out switch to move the debarker all the way in. Turn the key to OFF (0) and remove the key. This will prevent the debarker from being turned on while performing alignment procedures.
2. Check the squareness of the debarker with the sawmill blade. Adjust the debarker mounts if necessary until the debarker is square with the sawmill blade.

Loosen the four debarker mounting bolts and use a mallet to adjust the mounting blocks. The mounting holes are oversized to allow small adjustments of the debarker. Tilt the debarker mount until the debarker is square with the sawmill blade.

Reighten the debarker mounting bolts to 20 ft.-lbs. torque. Tighten the two set screws in the mounting block holes to secure the debarker in its aligned position.

See Figure 3-1.

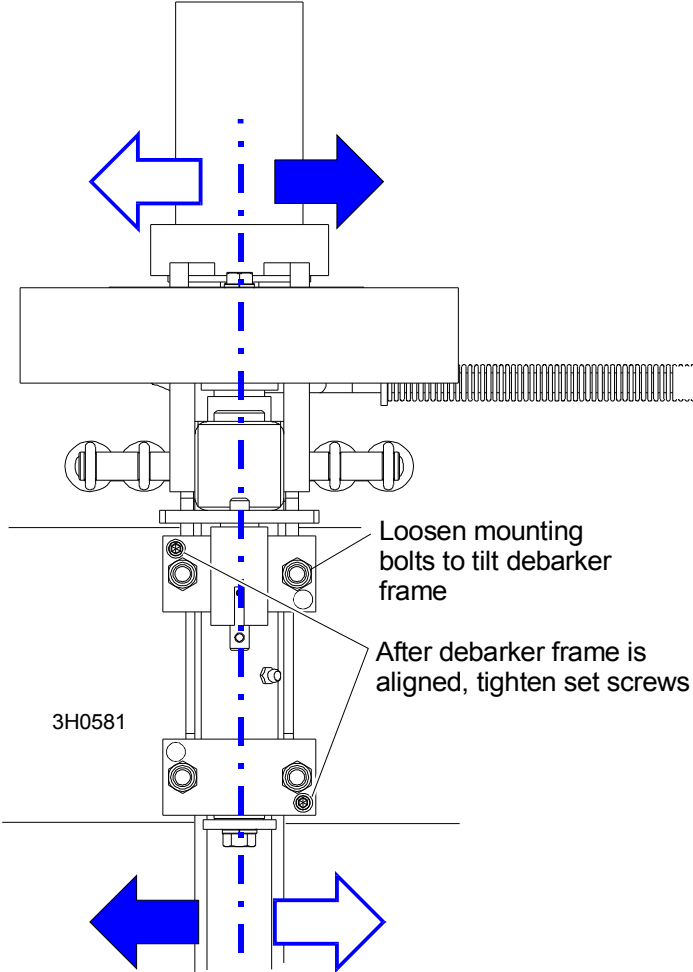

FIG. 3-1

- 3. Clip the blade guide alignment tool to the sawmill blade. Make sure the tool lies flat on the blade and does not contact a tooth that could cause it to angle.

3

Debarker Installation

See Figure 3-2.

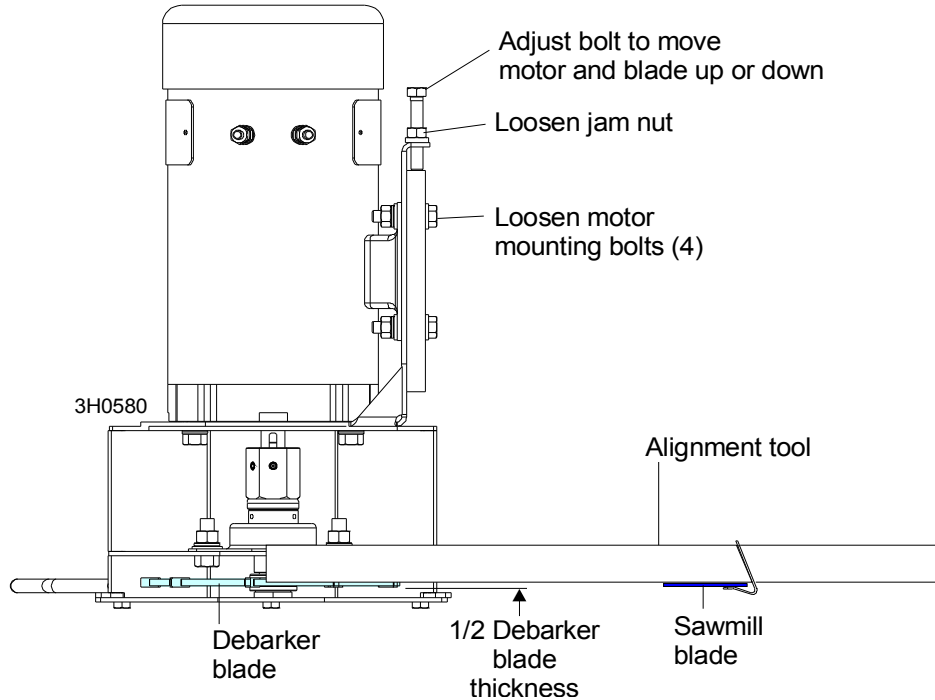

FIG. 3-2

4. Check the height of the debarker blade against the alignment tool. The bottom edge of the tool should align with the center of the debarker blade.

To adjust the blade up or down, loosen the four blade motor mount bolts. Loosen the jam nut on the adjustment bolt. Turn the adjustment bolt clockwise to push the motor and blade down. Turn the adjustment bolt counterclockwise and slide the motor up to raise the motor and blade. Retighten the adjustment bolt jam nut and four motor mount bolts.

5. Insert the key and use the debarker in/out switch to move the debarker all the way out. Turn the key to OFF (0) and remove the key.
6. Move the blade guide alignment tool on the sawmill blade and check the position of the debarker blade against the tool. If the debarker blade is not centered with the tool, readjust the debarker mounting bolts to adjust the debarker assembly parallel to the blade.

SECTION 4 OPERATION AND MAINTENANCE

4.1 Locking Pin Operation

See Figure 4-1. The debarker is equipped with a locking pin located where the debarker frame pivots in the mounting blocks. Three hole locations are provided for the locking pin. The inner two holes should be used to lock the debarker in place when towing the sawmill. Use the innermost hole if traveling without any options on the sawmill bed. Use the middle hole if traveling with an optional Shingle/Lap Siding or Resaw Attachment option. The outer position can be used to hold the debarker out of the way when debarking is not required during sawing.

NOTE: Debarkers before Rev. C.04 do not have the middle lock pin hole. Use the inner hole for travel and the outer hole for holding the debarker out of the way when not in use.

Before operating the debarker, make sure the locking pin is secured in its disengaged position. Turn the key switch to OFF (0) and remove the key. Pull the debarker out to relieve pressure on the locking pin. Pull the pin down and rotate so the small roll pin is aligned with the disengaged position slot. Release the locking pin.

Before towing the sawmill, lock the debarker in the travel position. Turn the key switch to ACC (3) and use the debarker in/out switch to move the debarker all the way in. Turn the key to OFF (0) and remove the key. Push the debarker in until the desired travel position hole aligns with the locking pin. Pull the pin down and rotate until the small roll pin is aligned with the engaged position slot. Release the locking pin.

To move the debarker out of the way during sawing, turn the key switch to ACC (3) and use the debarker in/out switch to move the debarker all the way out. Turn the key to OFF (0) and remove the key. Push the debarker out until the outer hole is aligned with the locking pin. Pull the pin down and rotate until the small roll pin is aligned with the engaged

4 Operation and Maintenance

Locking Pin Operation

position slot. Release the locking pin.

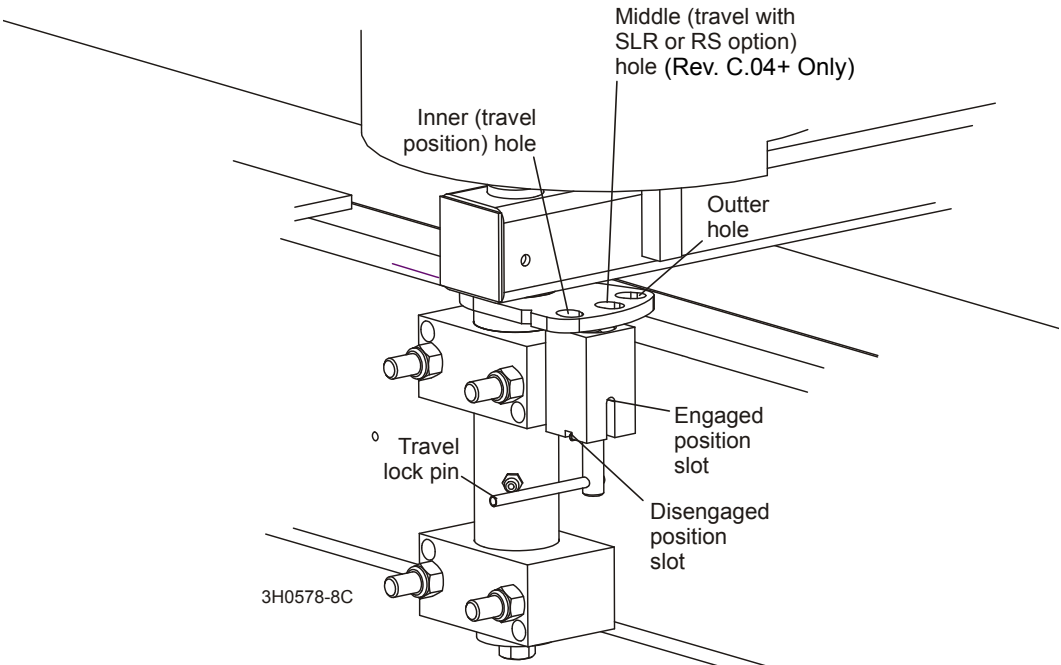

FIG. 4-1

4.2 Control Overview

The Debarker Option allows you to remove bark from logs ahead of the bandsaw blade. This prevents the bandsaw blade from contacting dirt, sand, or other debris in the bark that can dull the blade.

See **Figure 4-2**. The debarker control includes two toggle switches, an indicator light, and circuit breakers with manual reset.

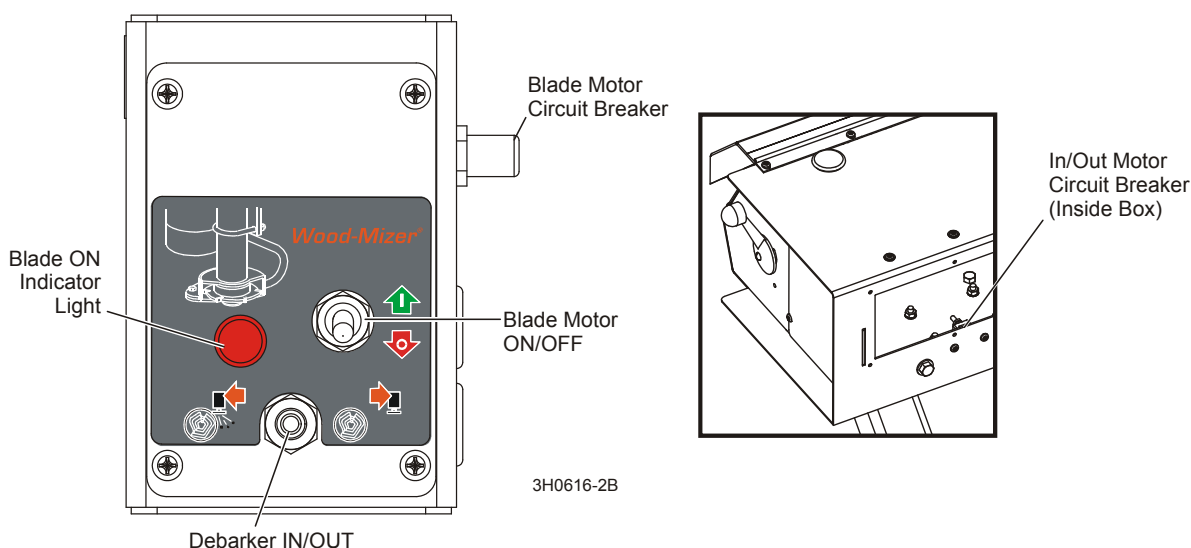

FIG. 4-2

- The Debarker IN/OUT toggle switch controls the debarker in/out motor to move the debarker cutting head toward or away from the log. The sawmill key switch must be on before the in/out function can be performed. **NOTE:** The distance between the debarker blade and the side support with the cutting head all the way in is 6" (150mm) for the sawmill equipped with the standard head and 12" (300mm) for the sawmill equipped with the wide head.
- The Blade Motor ON/OFF toggle switch turns the blade motor on to start the debarker blade. The sawmill key switch must be on and the sawmill power feed drum switch must be activated in the forward direction before the blade motor can be turned on.
- The Blade ON indicator light comes on whenever the debarker blade motor is on.
- The blade motor circuit breaker can be reset by pushing the boot-covered tab on the side of the control box.

4 **Operation & Maintenance**

Control Overview

4.3 Operation



DANGER! Make sure all guards and covers are in place and secured before operating the debarker option. Failure to do so may result in serious injury.

DANGER! Keep all persons out of the path of moving equipment when operating the debarker. Failure to do so will result in serious injury.

1. Remove the blade motor cover before operating the debarker.
2. Make sure the warning light is on (or bell sounds prior to Rev. C.05) when the debarker is turned on.



WARNING! Debarker is ON when warninglight is on (or bell sounds prior to Rev. C.05). DO NOT disconnect the warning light (or bell). Doing so may result in serious injury.

3. Use the in/out switch on the control box to pivot the debarker all the way out.



4. Move the sawmill carriage forward and pivot the debarker in until the front fence engages with the end/side of the log.

5. Turn the debarker on/off switch to ON (1).



6. Proceed with cutting. The actuator will keep the debarker against the side of the log. Depending on log shape, you may have to pivot the debarker in and out for smooth cutting.



NOTE: The debarker can continuously remove up to approximately 1” of material from the log; no motor cool down time is required. Slower feed rates may be required for optimal debarker operation.

7. Once the carriage is past the end of the log, pivot the debarker away from the log. Return the carriage.



IMPORTANT! Should the carriage be returned before the debarker has been pivoted out of the way of the log, the debarker is designed to pivot upwards. If this happens, continue to **SLOWLY** return the carriage; or stop, pivot the debarker out and then return the carriage. **DO NOT** move the carriage forward while the debarker is contacting the log without the blade spinning.

8. When done sawing and ready to store or transport the sawmill, replace the debarker blade motor cover. Place the debarker in its travel position before towing the sawmill ([See Section 4.1](#)).

4.4 Maintenance



DANGER! Before performing any service to this equipment, turn the key to the OFF (0) position and remove the key. Failure to do so will result in serious injury or death.

1. Lubricate the two or three pivot joints with a NLGI #2 grade lithium grease every 40 hours of operation (third fitting added to travel pin block 11/07).

See Figure 4-3.

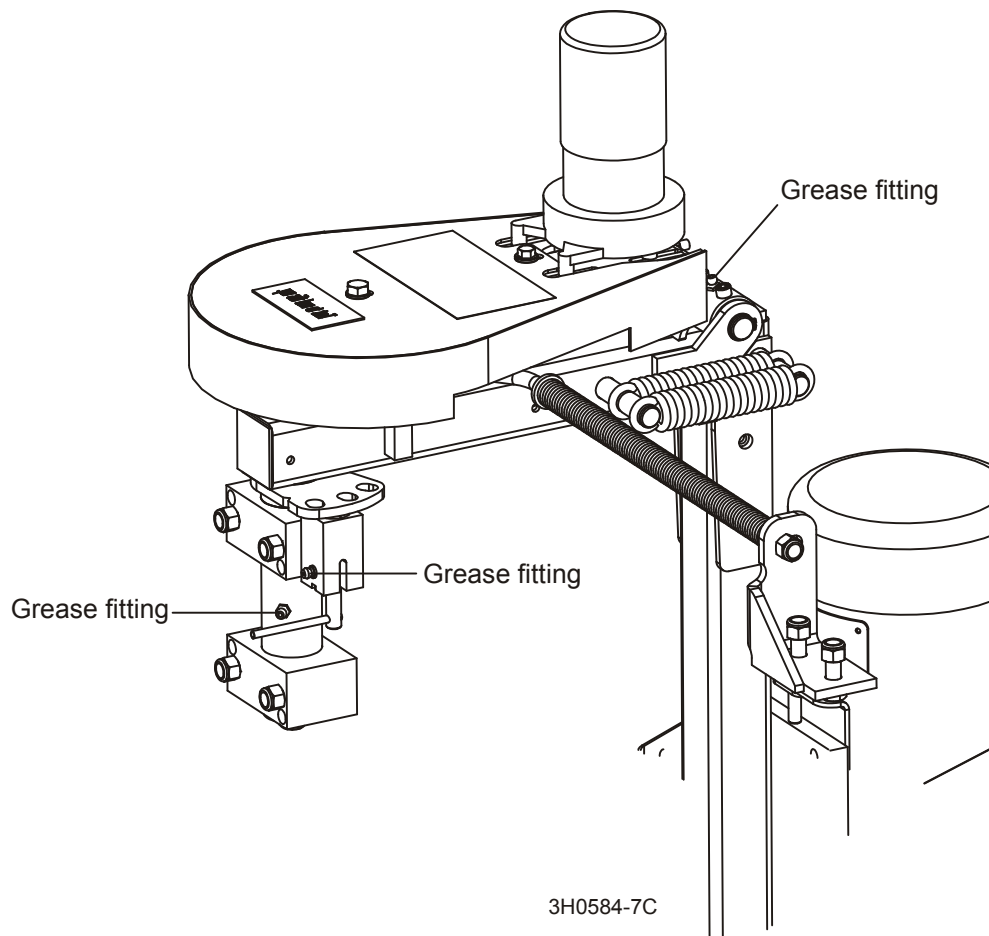

FIG. 4-3

2. Periodically check the flexible guard. Adjust the guard up or down so the bottom is even with the bottom of the debarker blade. Replace the guard as needed.

3. Periodically check the debarker blade. Align or replace as needed.



WARNING! Before replacing the debarker blade, move the sawmill blade guide arm in front of the sawmill blade to cover the blade teeth. Failure to do so may result in serious injury or death.

To replace the debarker blade, remove the lower blade guard plate. Place one wrench on the blade arbor, above the blade bearing. Place the other wrench on the lower bolt and rotate clockwise (bolt has left-hand threads). Remove the bolt and washer. Remove the blade and spacer.

Reinstall the spacer with the new blade. Reinstall the bolt and washer and turn counter-clockwise to tighten to 35 foot-pounds (± 5). Reinstall the blade guard plate.



CAUTION! Tighten the blade bolt manually. Using power-assisted tools may result in over-torquing and damage to the bolt.

4. Periodically check belt for tension and wear. Adjust or replace as necessary. To tighten the belt, turn the key switch to OFF (0) and remove the key. Remove the belt guard and loosen the four motor mount screws. Turn the adjustment nut clockwise to move the motor out and tighten the belt. The belt should be tensioned to allow $3/8$ " deflection measured halfway between the pulleys with 3-5 lbs. of force. Retighten the motor mount screws and replace the belt guard.

See Figure 4-4.

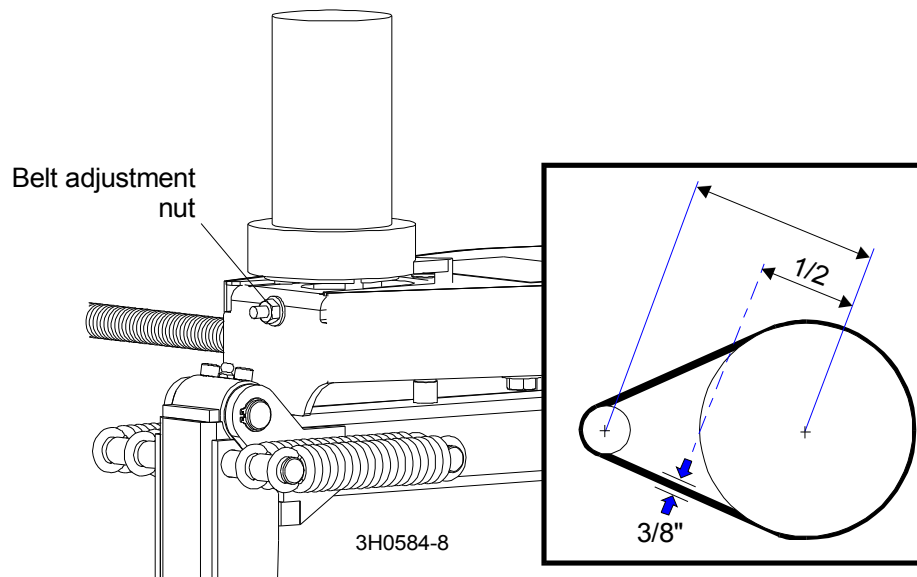

FIG. 4-4

5. Apply a dry lubricant such as Teflon spray or silicon to the spring rod and spring every 40 hours of operation.

4.5 Troubleshooting



DANGER! Before performing any service to this equipment, turn the key to the OFF (0) position, remove the key, and disconnect the sawmill battery ground terminal. Failure to do so will result in serious injury or death.

PROBLEM	CAUSE	SOLUTION
70 amp circuit breaker tripping	Wood or bark jammed in blade guard	Turn key to OFF position, remove key. Remove wood or bark from blade guard
	Pivot pin is binding.	Inspect for bind by moving debarker head to full in position. Turn key to OFF position, remove key. Pull arm to full out position by hand. If available, use a weight scale to pull arm to full out position. Should not have more than 12 pounds of resistance to pull out. Ensure pivot pin has been greased properly. Check pivot clamps for correct installation. Loosen pivot clamp bolts slightly, check for reduced binding
	Ring terminal of red wire touching debarker motor housing at motor	Move terminal away from motor housing. Reset circuit breaker and retest.
Light comes on, but debarker motor and warning light do not operate	Circuit breaker weak from repeated tripping.	Replace circuit breaker
	Circuit breaker tripped	Reset circuit breaker.
Debarker shuts off, but the circuit breaker is not tripped.	Bad ignition wire connection	Check ignition wire connection outside and inside of debarker control box.
	Intermittent key switch	Replace key switch
	Other loose wiring connection	Check wiring connections inside control box.
Debarker will not shut off.	Solenoid is stuck closed.	Replace solenoid.
IN/OUT Motor does not move IN or OUT	Drive belt too loose	Tighten enough to allow movement. DO NOT OVER-TIGHTEN.
	Switch not working properly	Check wiring to switch for loose connections. If wiring looks OK, replace switch.

SECTION 5 ELECTRICAL INFORMATION

5.1 Electrical Symbol Diagram

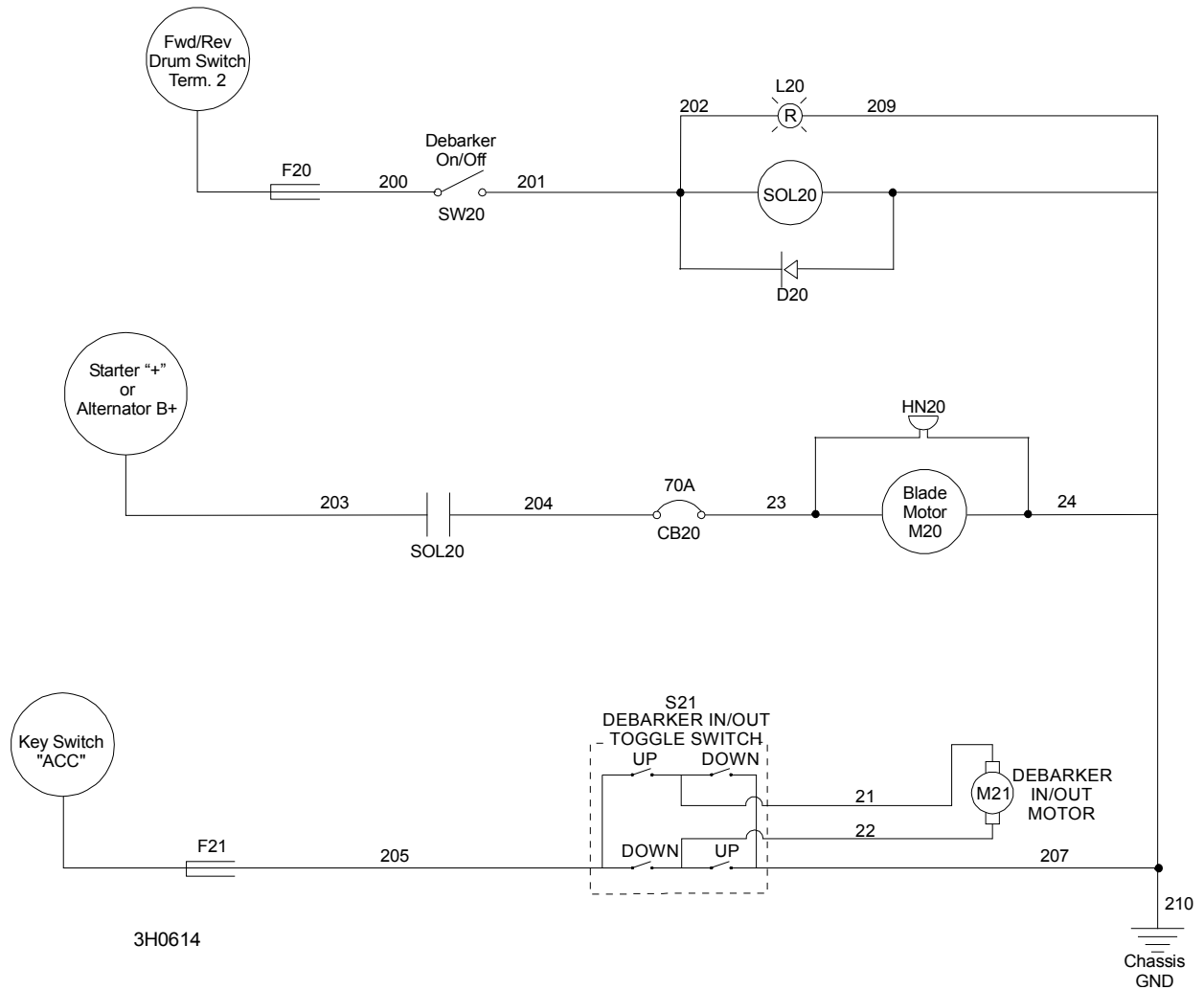

FIG. 5-1

5.2 Electrical Component List

ID	Wood-Mizer Part No.	Description
CB20	015527	Breaker, 70 A Manual Reset Panel Mount Circuit
D20	015426	Diode Assembly, Solenoid Coil Chassis
F20	024150-3	Fuse, 3A ATO
F21	024150-15	Fuse, 15A ATO
HN20	073555	Light Assembly, Debarker ON Warning Strobe (Rev. C.05+)
HN20	021137	Horn, Debarker ON Warning (Prior to Rev. C.05+)
L20	E20482	Light, Red 12 Volt Quick Connect
M20	023688 ¹	Motor, 12 V DC 3/4HP TEFC W/Base 7/8" Dia. Shaft
	015174 ¹	Motor, 12 V DC 3/4HP TEFC W/Base 5/8" Dia. Shaft
M21	P09698-1	Motor, 53:1 Gear
SOL20	016372 ²	Solenoid, 12V 100A Cont Duty GND Coil
SW20	P03027	Switch, Toggle
SW21	024200	Switch, DPDT Toggle

¹ 023688 Motor with 7/8" shaft replaces 015174 Motor with 5/8" dia. shaft (Rev. B.00). To upgrade Rev. A.00 Debarker with new motor requires new mandrel 023689.

² Solenoid Kit 016372 replaces Solenoid P10449. Kit includes solenoid and replacement instructions.

Electrical Wiring Diagram

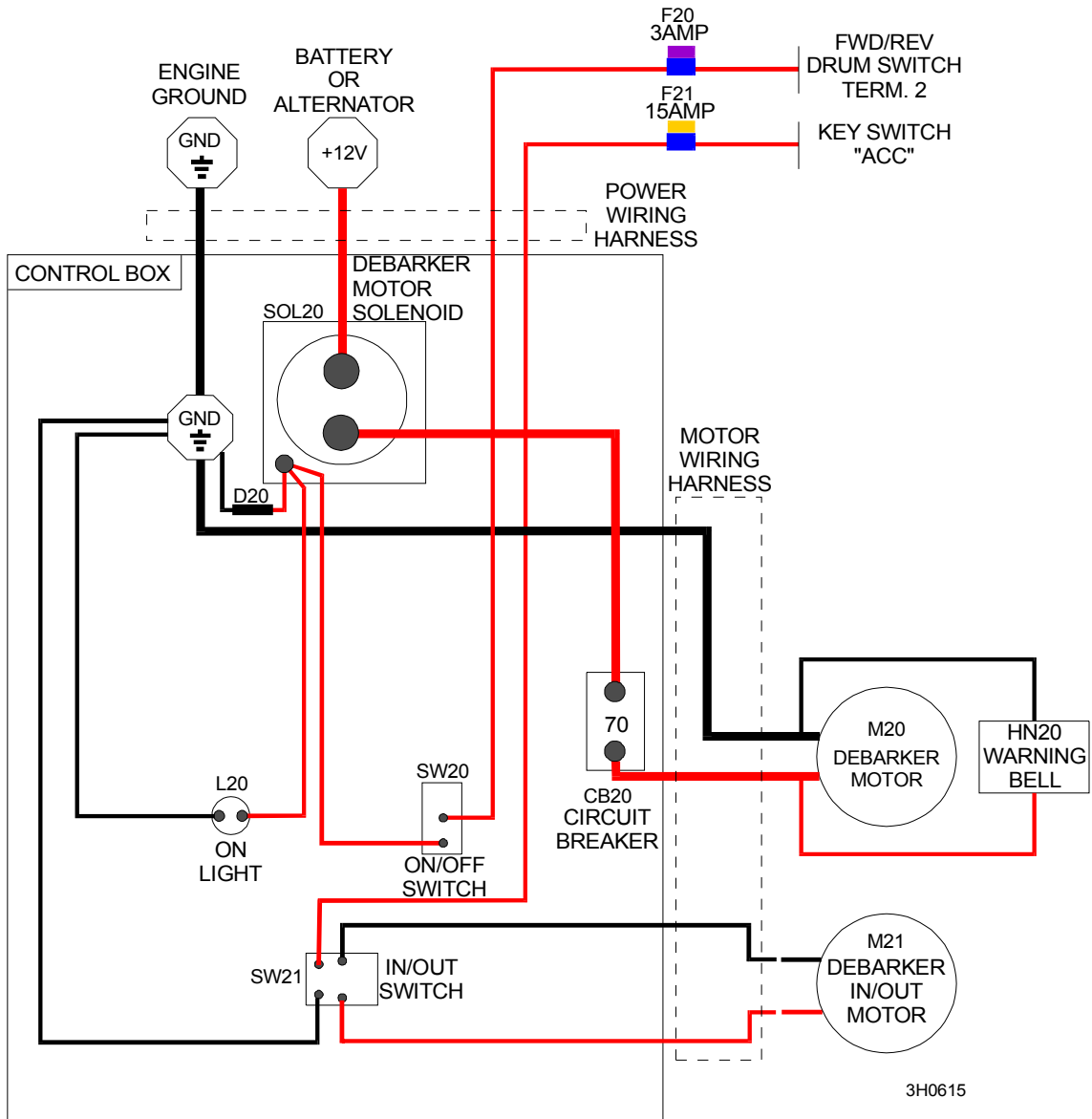
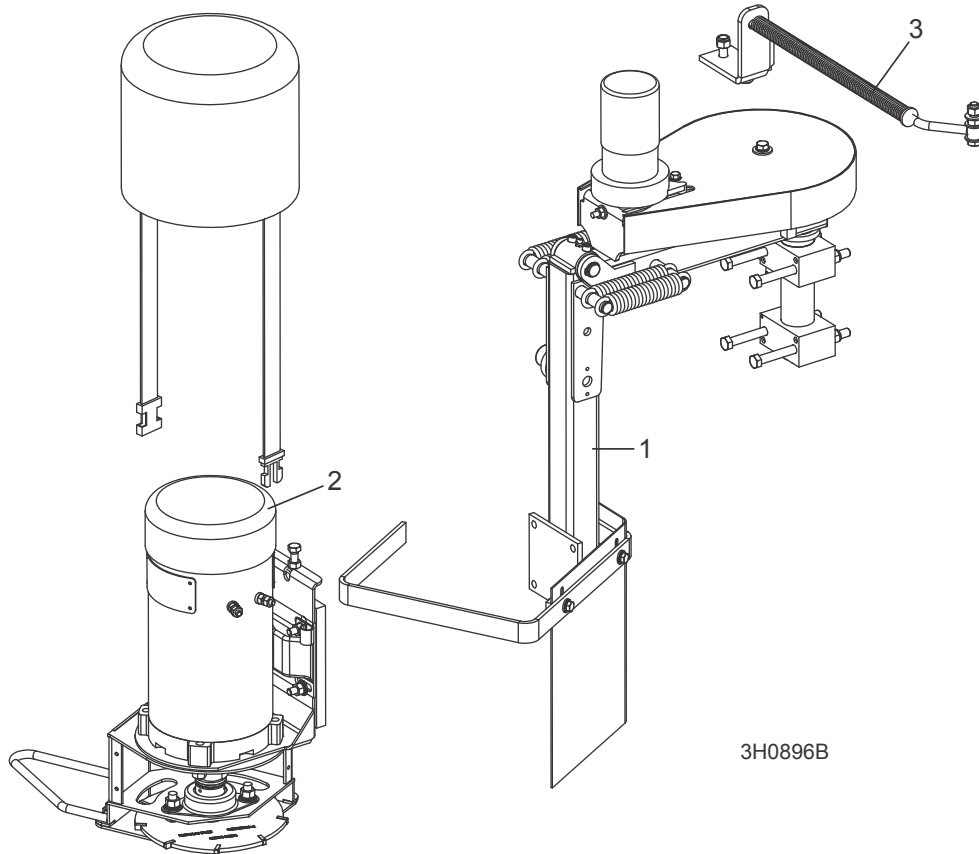

FIG. 5-2

SECTION 6 DEBARKER PARTS

6.1 Mechanical Assembly



REF	DESCRIPTION (◆ Indicates Parts Available In Assemblies Only)	PART #	QTY.
For field installation of existing sawmills, order the mechanical assembly below plus the appropriate control kit (See Section 6.10):			
	MECHANICAL ASSEMBLY, MKII DEBARKER	023617	1
1	Frame Parts (See Section 6.2)		
2	Cutter Head Parts (See Section 6.5)		
3	Spring Rod Parts (See Section 6.9)		

6.2 Frame Assembly

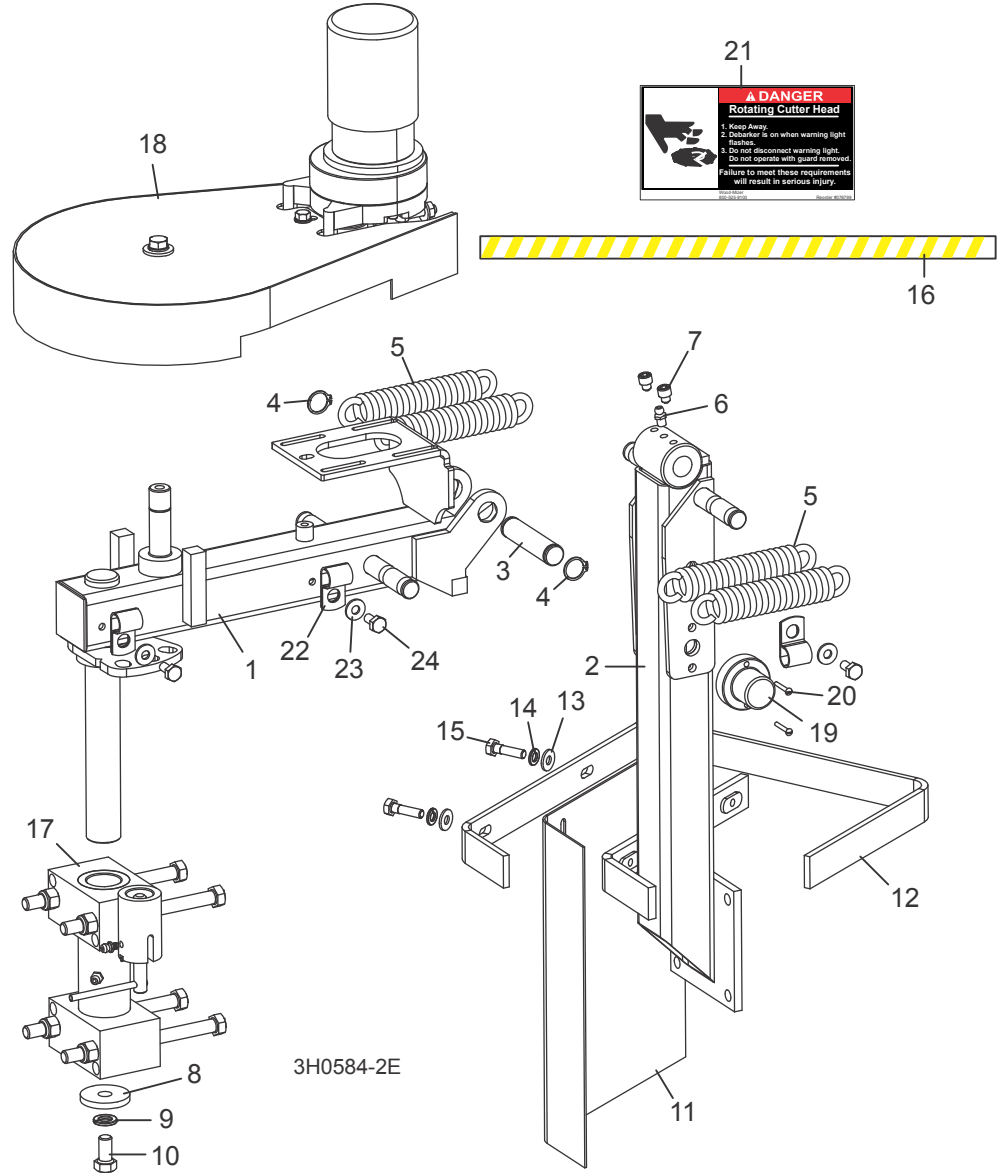

3H0584-2E

REF	DESCRIPTION (◆ Indicates Parts Available In Assemblies Only)	PART #	QTY.
	FRAME ASSEMBLY, MKII DEBARKER	023619	1
1	Arm Weldment, Debarker Upper	023641 ¹	1
2	Arm Weldment, Debarker Lower	023613	1
3	Pin, Debarker Frame Pivot	023646	1
4	Ring, 5/8" 5100-62 Outer Retaining	F04254-2	2
5	Spring, Debarker Arm	021185	4
6	Fitting, 1/4-28 Grease	P05060	1

6

Debarker Parts*Frame Assembly*

7	Screw, 1/4-28 x 1/4" Socket Head	F05005-106	2	
8	Washer, .40 x 1.44 x .18	021276	1	
9	Washer, 3/8" Split Lock	F05011-4	1	
10	Bolt, 3/8-16 x 3/4" Hex Head Grade 2	F05007-27	1	
11	Guard, Debarker Flexible Debris	021232	1	
12	Guard, Debarker Wrap-Around	021231	1	
13	Washer, 1/4" SAE Flat	F05011-11	2	
14	Washer, 1/4" Split Lock	F05011-14	2	
15	Bolt, 1/4-20 x 1" Hex Head Grade 2	F05005-38	2	
16	Decal, Debarker Guard	015849	1	
17	Mount Parts (See Section 6.3)			
18	In/Out Motor Parts (See Section 6.4)			
19	Lamp Assembly, 180 Degree Amber Strobe	073555	1	
20	Bolt, 4-40x3/4 S	F05004-13	2	
21	Decal, Debarker Light Warning	076799	2	
22	CLAMP, 1/2" EMT COATED	P07584	3	
23	WASHER, 1/4" SAE FLAT	F05011-11	3	
24	BOLT, 1/4-20 X 1/2" HEX HEAD	F05005-15	3	

¹ Middle locking pin hole added to store Debarker in travel position if SLR or RS option mounted on sawmill bed (Rev. C.04).

6.3 Mount/Lock Pin Assembly

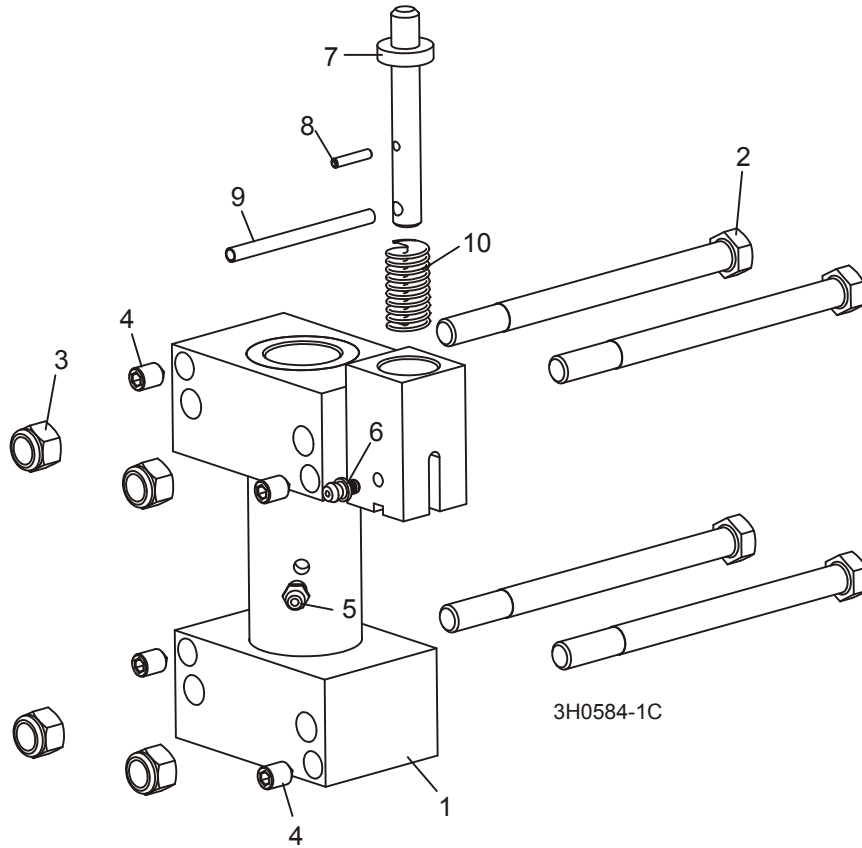

REF	DESCRIPTION (◆ Indicates Parts Available In Assemblies Only)	PART #	QTY.	
	PIVOT KIT, DEBARKER MOUNT	021284	1	
1	Mount Weldment, Debarker Frame Pivot	021282	1	◆
2	Bolt, 3/8-16 x 5" Hex Head	F05007-5	4	
3	Nut, 3/8-16 Hex Nylon Lock	F05010-10	4	
4	Screw, 5/16-24 x 1/2" Cone Point Socket Set	F05006-96	4	
5	Fitting, 1/4-28 Grease	P05060	1	
6	Fitting, 3/16" x 3/16" Straight Grease	P04107 ¹	1	
7	PIN, DEBARKER LOCK	023650	1	
8	PIN, 1/8" X 1" ROLL	F05012-34 ²	1	
9	PIN, 3/16" X 2 1/2" ROLL	F05012-27	1	
10	SPRING, .58" OD X 1 1/8" LONG COMPRESSION	021243	1	

¹ Grease fitting added to travel pin block 11/07.

² 1" Roll Pin F05012-34 replaces 5/8" Roll Pin F05012-14 for easier assembly (4/08).

6 Debarker Parts
In/Out Motor Drive Assembly

6.4 In/Out Motor Drive Assembly

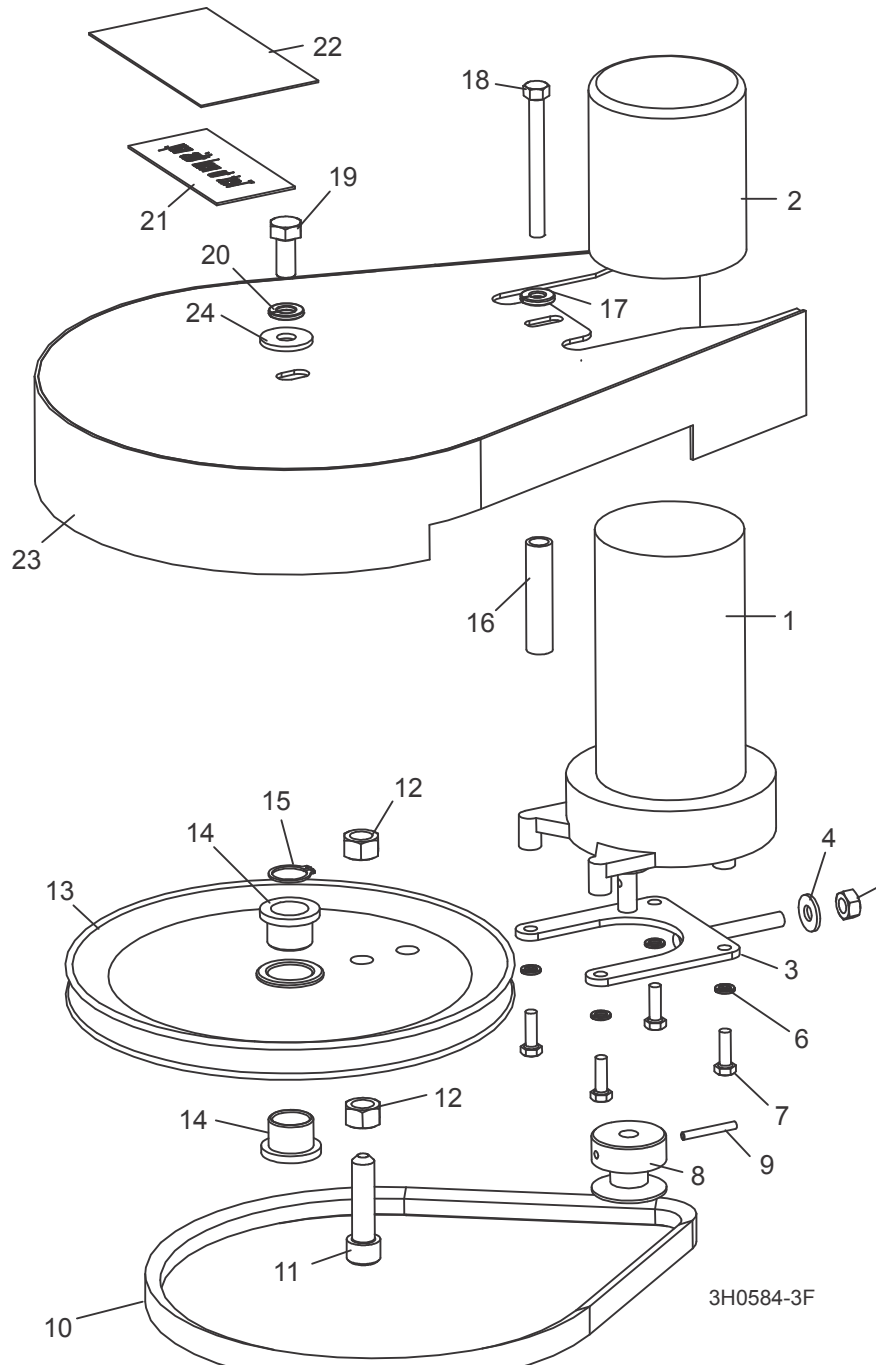

REF	DESCRIPTION (◆ Indicates Parts Available In Assemblies Only)	PART #	QTY.
1	MOTOR, CURRENT APPLICATIONS 1/30HP 12VDC GEAR	079214 ¹	1
	Gear Kit, Gear Motor Replacement	061232	1

	Brush Kit, Gear Motor Replacement	061234	1	
	Shaft Kit, Gear Motor Replacement	061233	1	
2	BOOT, GEAR MOTOR WEATHER	023720	1	
3	TENSIONER WELDMENT, GEAR MOTOR	023637	1	
4	WASHER, 1/4" SAE FLAT	F05011-11	1	
5	NUT, 1/4-20 HEX LOCK	F05010-21	1	
6	WASHER, #10 SPLIT LOCK	F05011-20	4	
7	BOLT, #10-32 X 5/8" HEX HEAD	F05004-152	4	
8	PULLEY, DEBARKER IN/OUT MOTOR	016181 ²	1	
9	PIN, 1/8" X 1" ROLL	F05012-34 ²	1	
10	BELT, 4L280	P04031	1	
11	BOLT, 3/8-16 X 1 1/2" SOCKET HEAD	F05007-36	1	
12	NUT, 3/8-16 HEX LOCK	F05010-25	2	
13	PULLEY, DEBARKER IN/OUT DRIVE	023634	1	
14	BUSHING, FLANGED BRONZE	021203	2	
15	RING, 5/8" 5100-62 OUTSIDE RETAINING	F04254-2	1	
16	SPACER, 5/16" ID X 7/16" OD X 1 15/16" LONG	014424	1	
17	WASHER, 1/4" SPLIT LOCK	F05011-14	1	
18	BOLT, 1/4-20 X 2 1/2" HEX HEAD	F05005-7	1	
19	BOLT, 5/16-18 X 3/4" HEX HEAD GRADE 2	F05006-5	1	
20	WASHER, 5/16" SPLIT LOCK	F05011-13	1	
21	DECAL, DEBARKER REVISION	016187	1	
22	OVERLAY, REVISION DECAL	016200	1	
23	GUARD WELDMENT, DEBARKER PULLEY	023649	1	
24	WASHER, 5/16" STANDARD FLAT	F05011-16 ³	1	

¹ Replaced P09698-1 1/30 HP 62RPM 12VDC 53:1 Gear Motor with P12756 End Housing, P12569 Gear Kit, P12800 Brush Kit and 009695 Shaft Kit (Rev. C.06).

² Gear Motor Pulley 016181 and Roll Pin F05012-34 replace Gear Motor Pulley 021190 with 1/4-20 x 3/8" Cup Point Set Screw F05005-47 originally supplied prior to Rev. C.01. Roll pin required to install new pulley to older revision Debarkers.

³ Added 2/10 to cover slot to prevent moisture entering guard.

6.5 Blade Motor Assembly

Rev. C.05+

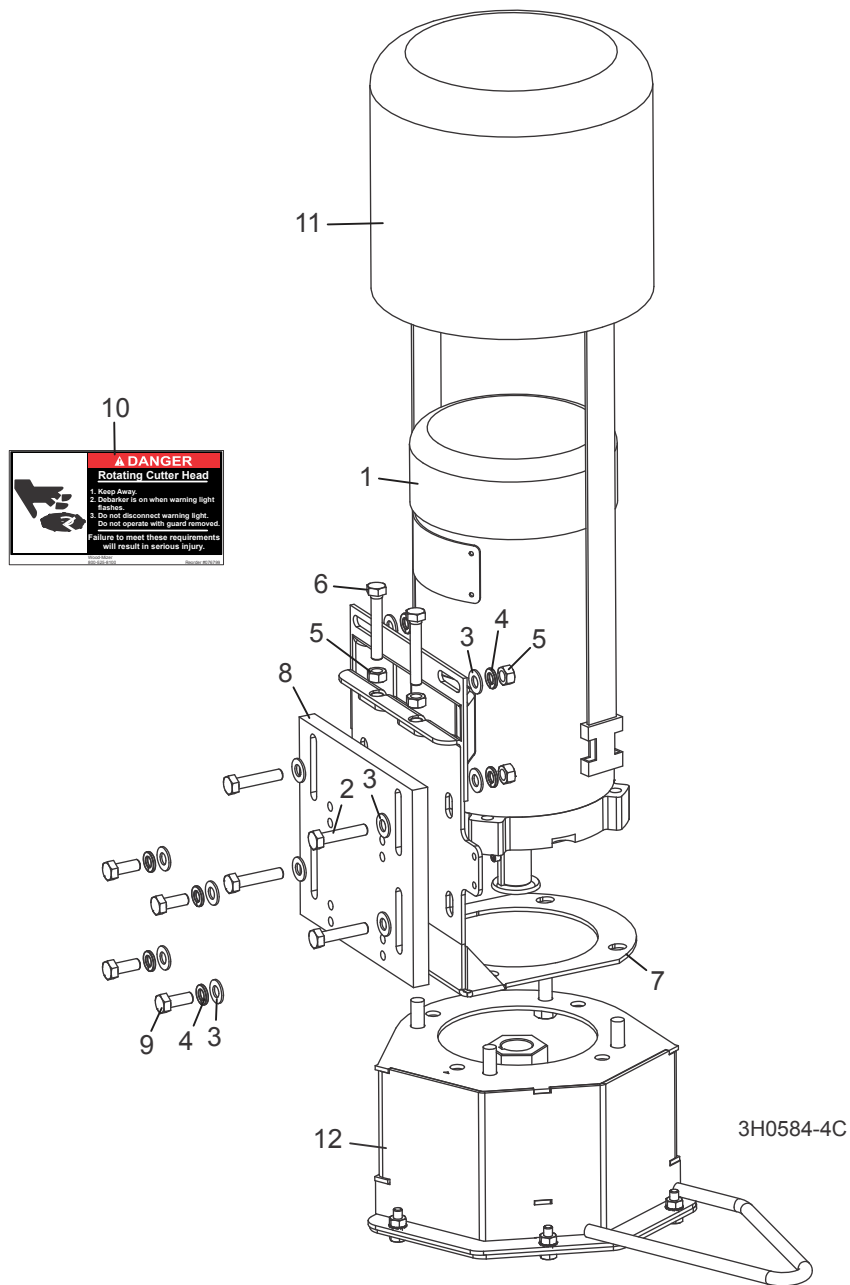

REF	DESCRIPTION (◆ Indicates Parts Available In Assemblies Only)	PART #	QTY.
	HEAD ASSEMBLY, MKII DEBARKER CUTTING	023618	1
1	Motor, 3/4HP 12VDC TEFC Electric (7/8" Dia. Shaft)	023688 ¹	1
	Motor, 3/4HP 12VDC TEFC Electric (5/8" Dia. Shaft)	015174 ¹	1
	Brush Kit, Leeson 3/4HP Motor (Includes 2 Brushes and 2 Springs)	024167	1
	Fan, 3/4 HP Leeson Motor Replacement	016087	1

Debarker Parts 6

Blade Motor Assembly

	Guard, Motor Fan	047998	1	
	Key, 3/16" Square x 1 3/8" Long	016108	1	
2	Bolt, 5/16-18 x 1 1/2" Hex Head Full Thread	F05006-2	4	
3	Washer, 5/16" SAE Flat	F05011-17	8	
4	Washer, 5/16" Split Lock	F05011-13	8	
5	Nut, 5/16-18 Hex	F05010-17	6	
6	Bolt, 5/16-18 x 2" Hex Head Full Thread	F05006-13	2	
7	Bracket Weldment, Debarker Blade Motor Adjustable	023622	1	
8	Plate, Debarker Blade Motor Mount	023620	1	
9	Bolt, 5/16-18 x 3/4" Hex Head Grade 2	F05006-5	4	
10	Decal, Debarker Light Warning	076799	1	
11	Cover, 3/4HP Leeson Motor	015761	1	
12	Blade/Mandrel Parts (See Section 6.7)			

¹ 023688 Motor with 7/8" shaft replaces 015174 Motor with 5/8" dia. shaft (Rev. B.00). To upgrade Rev. A.00 Debarker with new motor requires new mandrel ([See Section 6.7](#)).

6.6 Blade Motor Assembly

Rev. A.00 - C.04

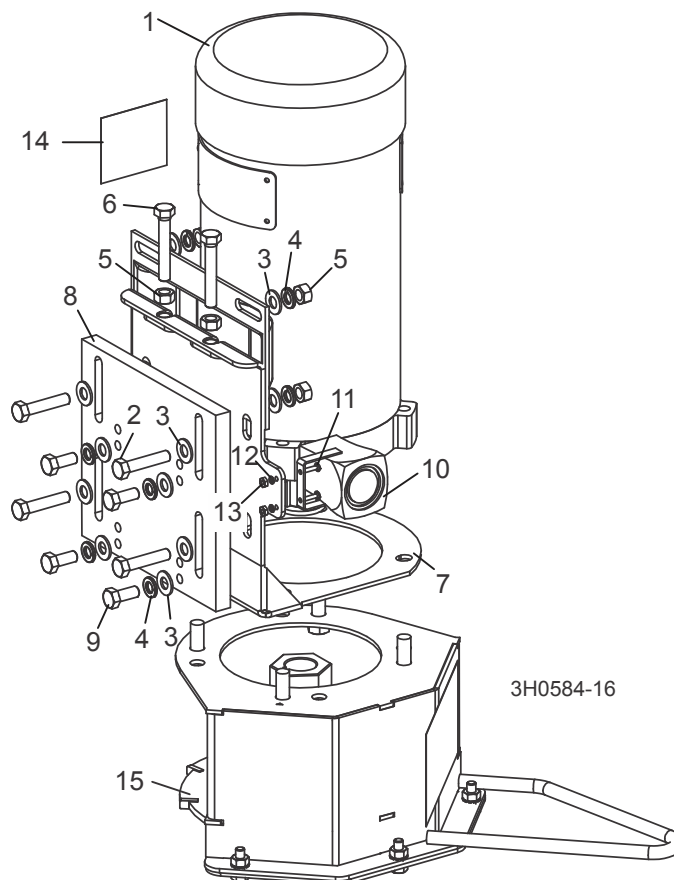

REF	DESCRIPTION (◆ Indicates Parts Available In Assemblies Only)	PART #	QTY.
	HEAD ASSEMBLY, MKII DEBARKER CUTTING	023618	1
1	Motor, 3/4HP 12VDC TEFC Electric (7/8" Dia. Shaft)	023688 ¹	1
	Motor, 3/4HP 12VDC TEFC Electric (5/8" Dia. Shaft)	015174 ¹	1
	Brush Kit, Leeson 3/4HP Motor (Includes 2 Brushes and 2 Springs)	024167	1
	Fan, 3/4 HP Leeson Motor Replacement	016087	1
	Guard, Motor Fan	047998	1
	Key, 3/16" Square x 1 3/8" Long	016108	1
2	Bolt, 5/16-18 x 1 1/2" Hex Head Full Thread	F05006-2	4
3	Washer, 5/16" SAE Flat	F05011-17	8
4	Washer, 5/16" Split Lock	F05011-13	8
5	Nut, 5/16-18 Hex	F05010-17	6
6	Bolt, 5/16-18 x 2" Hex Head Full Thread	F05006-13	2
7	Bracket Weldment, Debarker Blade Motor Adjustable	023622	1
8	Plate, Debarker Blade Motor Mount	023620	1
9	Bolt, 5/16-18 x 3/4" Hex Head Grade 2	F05006-5	4
10	Horn, 12V DC	021137	1

Debarker Parts
Blade Motor Assembly

6

11	Screw, 4-40x1/2 SI Rnd Head Machine	F05004-14	2	
12	Washer, #4 Split Lock	F05011-21	2	
13	Nut, #4-40 Hex	F05010-43	2	
14	Decal, Disconnect Motor Leads Warning	024431	1	
15	Blade/Mandrel Parts (See Section 6.7)			

¹ 023688 Motor with 7/8" shaft replaces 015174 Motor with 5/8" dia. shaft (Rev. B.00). To upgrade Rev. A.00 Debarker with new motor requires new mandrel ([See Section 6.7](#)).

6.7 Blade Housing Assembly

Rev. C.00+

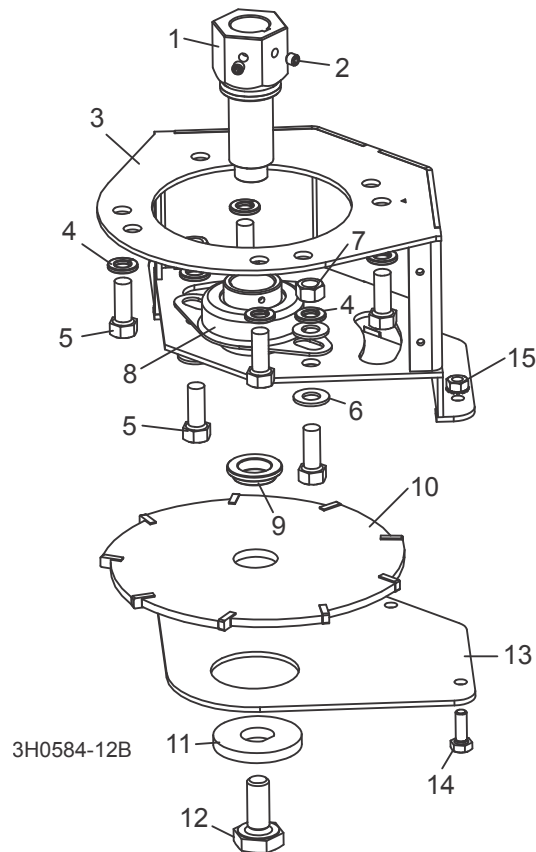

REF	DESCRIPTION (◆ Indicates Parts Available In Assemblies Only)	PART #	QTY.	
1	MANDREL, DEBARKER BLADE (7/8" DIA.)	016122 ¹	1	
2	SCREW, 1/4-28 X 1/4" CUP POINT SOCKET SET	F05005-105	2	
3	HOUSING WELDMENT, DEBARKER BLADE	023628 ²	1	
4	WASHER, 3/8" SPLIT LOCK	F05011-4	6	
5	BOLT, 3/8-16 X 1" HEX HEAD	F05007-7	6	
6	WASHER, 3/8" SAE FLAT	F05011-3	4	
7	NUT, 3/8-16 HEX	F05010-1	2	
8	BEARING, 1" FLANGED MOUNT	023541	1	
9	BUSHING, DEBARKER BLADE SPACER	023632	1	
10	BLADE, DEBARKER 7" DIA.	021236	1	
	BLADE, DEBARKER 7" DIA. W/1/2" INSERTS (OPTIONAL - PURCHASED SEPARATELY)	065852	1	
11	WASHER, DEBARKER BLADE LOCK	023737 ¹	1	
12	BOLT, 1/2-20 X 1 1/4" HEX HEAD SPECIAL	023547 ³	1	

13	PLATE, DEBARKER BLADE HOUSING BOTTOM	023629	1	
14	BOLT, 1/4-20 X 3/4" HEX HEAD FULL THREAD	F05005-1	3	
15	NUT, 1/4-20 SELF-LOCKING HEX	F05010-9	3	

¹ Mandrel and washer with "D"-shaped hole used to prevent slippage (Rev. C.00).

² Housing weldment modified to accept CE guards required in Europe (Rev. C.00).

³ Radius added to blade bolt 023547 to prevent damage caused by over-torquing of the bolt (Rev. C.00).

6.8 Blade Housing Assembly

Rev. A.00 - B.00

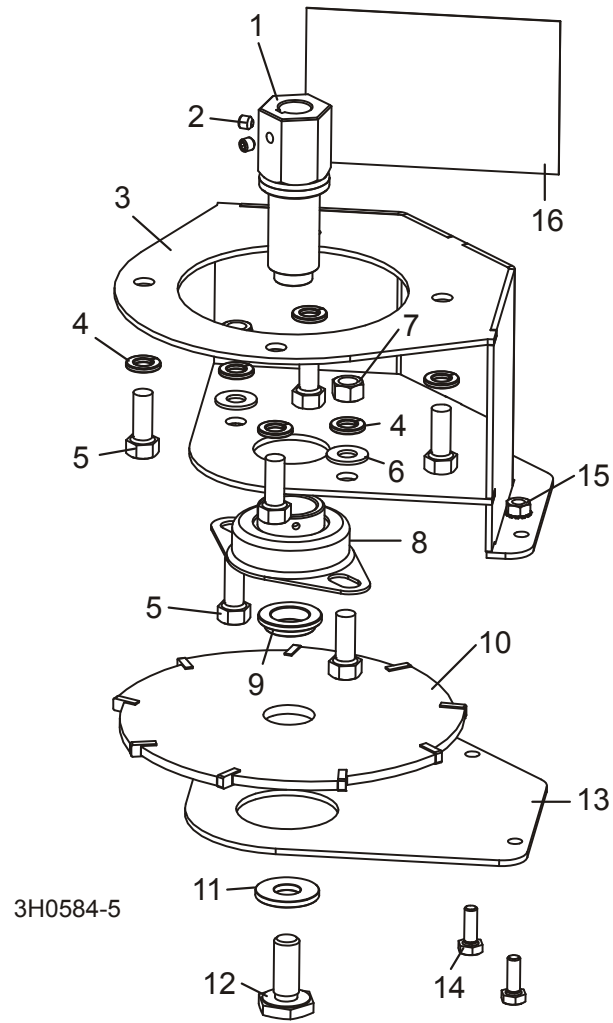

REF	DESCRIPTION (◆ Indicates Parts Available In Assemblies Only)	PART #	QTY.	
1	MANDREL, DEBARKER BLADE (7/8" DIA.)	023689 ¹	1	◆
	MANDREL, DEBARKER BLADE (5/8" DIA.)	021385 ¹	1	
2	SCREW, 1/4-28 X 1/4" CUP POINT SOCKET SET	F05005-105	2	
3	HOUSING WELDMENT, DEBARKER BLADE	023628	1	
4	WASHER, 3/8" SPLIT LOCK	F05011-4	6	
5	BOLT, 3/8-16 X 1" HEX HEAD	F05007-7	6	
6	WASHER, 3/8" SAE FLAT	F05011-3	2	
7	NUT, 3/8-16 HEX	F05010-1	2	
8	BEARING, 1" FLANGED MOUNT	023541	1	
9	BUSHING, DEBARKER BLADE SPACER	023632	1	

10	BLADE, DEBARKER 7" DIA.	021236	1	
	BLADE, DEBARKER 7" DIA. W/1/2" INSERTS (OPTIONAL - PURCHASED SEPARATELY)	065852	1	
11	WASHER, DEBARKER BLADE RETAINING	023633	1	
12	BOLT, 1/2-20 X 1 1/4" HEX HEAD SPECIAL	023547	1	
13	PLATE, DEBARKER BLADE HOUSING BOTTOM	023629	1	
14	BOLT, 1/4-20 X 3/4" HEX HEAD FULL THREAD	F05005-1	3	
15	NUT, 1/4-20 SELF-LOCKING HEX	F05010-9	3	
16	DECAL, DEBARKER HORN DANGER	021172	1	

¹ 023689 7/8" Mandrel obsolete. Replace all 7/8" mandrels with 016122 mandrel and 023737 washer with "D"-shaped hole to prevent slippage ([See Section 6.7](#)). Use 021385 5/8" Mandrel with 015174 motor supplied with Rev. A.00 Debarkers.

6.9 Spring Rod Assembly

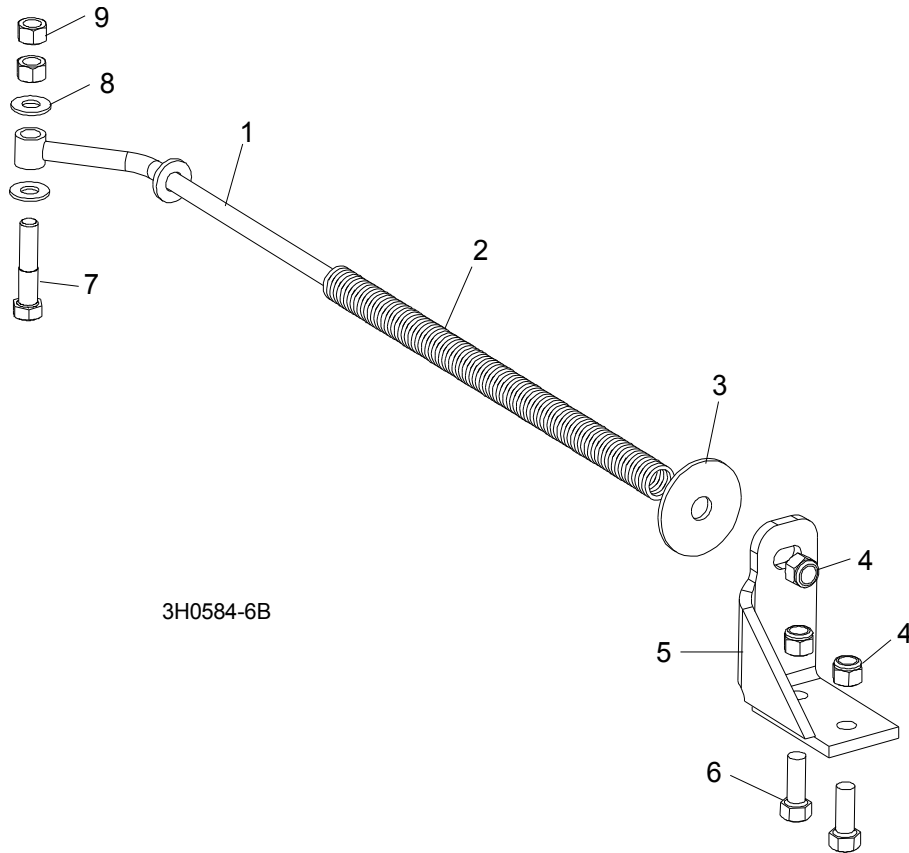

REF	DESCRIPTION (◆ Indicates Parts Available In Assemblies Only)	PART #	QTY.
1	ROD ASSEMBLY, DEBARKER SPRING	016182 ¹	1
1	Rod Weldment, Debarker Spring	021179	1
2	Spring, Debarker Compression	023631	1
3	Washer, 1/2" ID x 2" OD Fender	F05011-38	1
4	Nut, 3/8-16 Nylon Lock	F05010-10	3
5	Bracket, Spring Rod Mount	021180	1
6	Bolt, 3/8-16 x 1" Hex Head	F05007-7	2
7	Bolt, 3/8-16 x 1 3/4" Hex Head Grade 2	F05007-119	1
8	Washer, 3/8" SAE Flat	F05011-3	2
9	Nut, 3/8-16 Hex Lock	F05010-25	2

¹ New subassembly created with Rev. C.01 (10/98).

6.10 Debarker Control Box Assembly

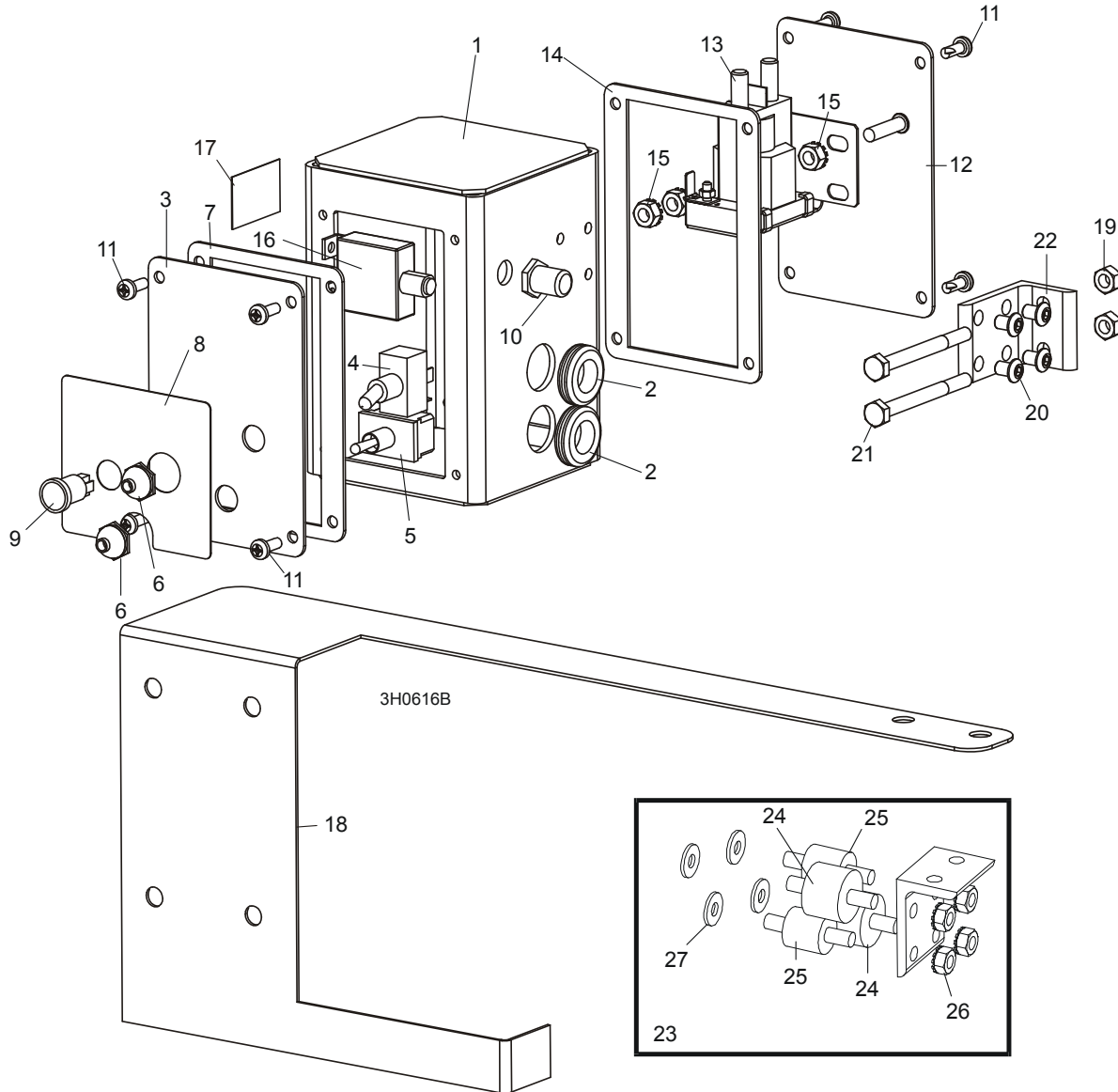

REF	DESCRIPTION (◆ Indicates Parts Available In Assemblies Only)	PART #	QTY.
	CONTROL KIT, MKII DEBARKER PRE-97 MILL	023678	1
	Control Assembly, Debarker	024423	1
1	Box Weldment, Debarker Control	024434	1
2	Grommet, 5/8" ID Rubber	P11764	2
	Panel Assembly, Debarker Front Control	024419	1
3	Panel, Debarker Front	024418	1
4	Switch, Toggle	P03027	1
5	Switch, DPDT Toggle	024200	1

6

Debarker Parts*Debarker Control Box Assembly*

6	Boot, Toggle Switch	P02575	2	
7	Gasket, Debarker Control Panel	021234	1	
8	Decal, Debarker Control Panel	021228	1	
9	Light, Red 12 Volt Quick Connect	E20482	1	
10	Boot, Circuit Breaker	021253	1	
11	Screw, #10-24 x 1/2" Slotted Phillips Head	F05015-17	8	
	Panel Assembly, Debarker Rear Control	024420	1	
12	Panel Weldment, Debarker Rear Control	024417	1	
13	Solenoid Kit, Accessory	016372 ¹	1	
	Solenoid, 100A 12V Cont. Duty GND	P10449	1	◆
	Diode Assembly, Solenoid Coil Chassis GND	015426	1	
14	Gasket, Debarker Control Panel	021234	1	
15	Nut, 1/4-20 Self-Locking Hex	F05010-9	3	
16	Breaker, 70A Manual Reset Panel Mount	015527	1	
	Harness Assembly, Debarker Power Wiring	024422	1	
	Harness Assembly, Debarker Motor Wiring	024425	1	
17	Decal, Debarker Revision	021285	1	
	Manual, Pre-97 MKII Debarker Option	M554	1	
18	Template, Debarker Mount	021248	1	
	Bag Assembly, Debarker Fastener	024428	1	
19	Nut, 1/4-20 Hex Lock	F05010-21	2	
20	Screw, 1/4-20 x 3/8" Socket Button Head	F05005-62	4	
21	Bolt, 1/4-20 x 1" Hex Head Grade 2 (for Standard Sawmill)	F05005-38	2	
	Bolt, 1/4-20 x 2 3/4" Hex Head Grade 2 (for Super Sawmill)	F05005-18	2	
22	Bracket, Debarker Control Box Mount	021223	1	
	Fuse Assembly, 15 Amp	024426	1	
	Fuse Assembly, 3 Amp	024427	1	
	Boot, 1/2" Rubber Terminal	P03807	1	
23	ISOLATOR KIT, DEBARKER VIBRATION (Required for pre-96 sawmills only)	021290	1	
24	Isolator, 1" O.D. Vibration	021292	2	
25	Isolator, 3/4" O.D. Vibration	021291	2	
26	Nut, 1/4-20 Self-Locking Hex	F05010-9	4	
27	Washer, 1/4" SAE Flat	F05011-11	4	
	Instruction Sheet, Debarker Isolator Retrofit	021290-517	1	

¹ Solenoid Kit 016372 replaces Solenoid P10449. Kit includes solenoid and replacement instructions. Diode Wire Assembly 015426 added to Solenoid Kit 016372 (8/04).

INDEX

A

alignment 3-1

E

electrical information 5-1
 component list 5-2
 symbol diagram (non-remote) 5-1
 wiring diagrams (non-remote) 5-3

I

installation 2-1
 control box 2-4
 control box mounting holes 2-3
 debarker 2-6
 frame mounting holes 2-2
 lower harness 2-1
 upper harness 2-7

M

maintenance 4-7

O

operation 4-5
 control overview 4-3
 locking pin 4-1

R

replacement parts 6-1
 blade housing 6-11, 6-13
 blade motor & horn 6-7, 6-9
 control 6-16
 frame 6-2
 in/out motor 6-5
 mechanical assembly 6-1
 mount/lock pin 6-4
 spring arm 6-15

S

safety 1-1
 installation & maintenance 1-1
 operation & towing 1-2

T

troubleshooting 4-10
