

# Debarker Option

## Safety, Installation, Operation, Maintenance & Parts Manual

---

**MKII for 97+ Sawmills    rev. A.00 - C.06**

---



**Safety is our #1 concern!** Read and understand all safety information and instructions before operating, setting up or maintaining this machine.

*April 1998*

*Form #546*

# Table of Contents

# Section-Page

<b>SECTION 1</b>	<b>SAFETY</b>	<b>1-1</b>
1.1	Installation and Maintenance.....	1-1
1.2	Operation and Towing.....	1-2
<b>SECTION 2</b>	<b>DEBARKER INSTALLATION</b>	<b>2-1</b>
2.1	Debarker Frame Mounting Holes.....	2-2
2.2	Debarker Installation.....	2-3
2.3	Lower Harness Installation.....	2-8
2.4	Control Component Installation (Non-Remote Mills).....	2-14
2.5	Control Component Installation (Remote Mills).....	2-21
<b>SECTION 3</b>	<b>ALIGNMENT</b>	<b>3-1</b>
<b>SECTION 4</b>	<b>OPERATION AND MAINTENANCE</b>	<b>4-1</b>
4.1	Locking Pin Operation.....	4-1
4.2	Control Overview.....	4-3
4.3	Operation.....	4-5
4.4	Maintenance.....	4-7
4.5	Troubleshooting.....	4-10
<b>SECTION 5</b>	<b>ELECTRICAL INFORMATION</b>	<b>5-1</b>
5.1	Electrical Symbol Diagram (Non-Remote).....	5-1
5.2	Electrical Symbol Diagram (Remote).....	5-2
5.3	Electrical Component List.....	5-3
5.4	Electrical Wiring Diagram (non-Remote Sawmills).....	5-4
	<i>LT40 Super Rev. J7.05+</i>	
	<i>LT30HD/40HD SuperRev. K3.04+</i>	
	<i>LT50HD Rev. A5.04+</i>	
	<i>LT30 Super Rev. J3.00 - J3.08</i>	
	<i>LT40 Super Rev. J4.00 - J7.04</i>	
	<i>LT30HD/40HD SuperRev. J8.00 - K3.03</i>	
	<i>LT50HD Rev. A1.01 - A5.03</i>	
	<i>LT30 Super Rev. F8.00 - J2.03</i>	
	<i>LT40 Super Rev. F9.00 - J3.03</i>	
	<i>LT30HD/40HD SuperRev. G1.00 - J7.03</i>	
	<i>LT30/40 All Revs</i>	
	<i>LT30HD/40HD All Revs</i>	
	<i>LT40HD-H HydroRev. J9.02+</i>	
5.5	Electrical Wiring Diagram (Remote Sawmills).....	5-9
	<i>LT40HD Super RemoteRev. K3.00+</i>	
	<i>LT50HD Remote Rev. A5.00+</i>	
	<i>LT40HD Remote Rev. K5.00+</i>	
	<i>LT30HD Super RemoteRev. J8.00 - J8.09</i>	
	<i>LT40HD Super RemoteRev. J8.00 - K2.00</i>	

# Table of Contents

# Section-Page

*LT50HD Remote Rev. A1.01 - A4.00*  
*LT40HD Remote Rev. H4.00 - K4.01*  
*LT30HD Super RemoteRev. G5.00 - J7.03*  
*LT40HD Super RemoteRev. G5.00 - J7.03*

5.6	Electrical Wiring Diagram (Wireless Sawmills).....	5-17
	<i>LT40HD WirelessRev. K1.01+</i>	
	<i>LT50HD WirelessRev. A2.01+</i>	

<b>SECTION 6</b>	<b>DEBARKER PARTS</b>	<b>6-1</b>
------------------	-----------------------	------------

6.1	Mechanical Assembly .....	6-1
6.2	Frame Assembly.....	6-2
6.3	Mount/Lock Pin Assembly.....	6-1
6.4	In/Out Motor Drive Assembly.....	6-2
6.5	Blade Motor Assembly.....	6-4
	<i>Rev. C.05+</i>	
6.6	Blade Motor Assembly.....	6-6
	<i>Rev. A.00 - C.04</i>	
6.7	Blade Housing Assembly .....	6-8
	<i>Rev. C.00+</i>	
6.8	Blade Housing Assembly .....	6-10
	<i>Rev. A.00 - B.00</i>	
6.9	Spring Rod Assembly.....	6-12
6.10	Debarker Control Assembly .....	6-13

<b>INDEX</b>	<b>I</b>
--------------	----------

## SECTION 1 SAFETY



This symbol calls your attention to instructions concerning your personal safety. Be sure to observe and follow these instructions. This symbol accompanies a signal word. The word **DANGER** indicates an imminently hazardous situation which, if not avoided, will result in death or serious injury. **WARNING** suggests a potentially hazardous situation which, if not avoided, could result in death or serious injury. **CAUTION** refers to potentially hazardous situations which, if not avoided, may result in minor or moderate injury to persons or equipment. Read all safety instructions before operating this equipment and observe all safety warnings!

### 1.1 Installation and Maintenance



**DANGER!** On electric mills, hazardous voltage inside the disconnect box, starter box, and at the electric motor can cause shock, burns, or death. Disconnect and lock out power supply before performing debarker installation! Follow all applicable electrical codes.

**DANGER!** Make sure all electrical installation, service and/or maintenance work is performed by a qualified electrician and is in accordance with applicable electrical codes. Failure to do so will result in serious injury or death.

**DANGER!** Before performing any service to this equipment, turn the key to the OFF position, remove the key, and disconnect the sawmill battery ground terminal. Failure to do so will result in serious injury or death.



**WARNING!** Before replacing the debarker blade, move the sawmill blade guide arm in front of the sawmill blade to cover the blade teeth. Failure to do so may result in serious injury or death.

## 1.2 Operation and Towing



**DANGER!** Make sure all guards and covers are in place and secured before operating the debarker option. Failure to do so may result in serious injury.

**DANGER!** Keep all persons out of the path of moving equipment when operating the debarker. Failure to do so will result in serious injury.

**DANGER!** Always remove the key from the control panel before preparing the debarker for towing. Failure to do so may result in serious injury.



**WARNING!** Debarker is ON when warning light (or bell sounds prior to Rev. C.05). DO NOT disconnect the warning light (or bell). Doing so may result in serious injury.

**WARNING!** If the debarker continues to run with the key switch in the OFF position, remove the negative battery terminal from the battery post.

DO NOT continue to operate the mill if the main key switch does not control debarker operation. Doing so could result in serious injury. Call Wood-Mizer customer service for more information.

## SECTION 2 DEBARKER INSTALLATION



**DANGER!** On electric mills, hazardous voltage inside the disconnect box, starter box, and at the electric motor can cause shock, burns, or death. Disconnect and lock out power supply before performing debarker installation! Follow all applicable electrical codes.

**DANGER!** Before performing any service to this equipment, turn the key to the OFF (0) position, remove the key, and disconnect the sawmill battery ground terminal. Failure to do so will result in serious injury or death.



**CAUTION!** Due to various design changes and past retrofits and options, you should very carefully look your mill over to determine Debarker compatibility before beginning Debarker installation.

The Debarker Option may be installed to most sawmills with the required up/down chains and 60 amp or larger alternator systems.

**See Table 2-1.** Look at your sawmill up/down chains to verify they are the proper style for use with the Debarker Option. Refer to the chart below to determine if the Debarker Option may be installed on your specific sawmill.

Up/Down Chain Type	Install Debarker?	Comments
Single #40	No	The Debarker Option can only be installed on sawmills equipped with dual up/down chains (after 7/86).
Dual #40	Yes, if USA chain. See comments.	"USA" should be stamped into the side plates of the chain. If it is not, you will need to replace the existing chains with the proper specified chains. If you did not receive replacement chains with your Debarker order and find that you need them, call Wood-Mizer Customer Service at <b>1-800-525-8100</b> . <b>Do not proceed with Debarker installation or further operation until your mill is equipped with the correct up/down chains.</b>
#50-2	Yes	The Debarker Option can be installed on any sawmill equipped with #50-2 up/down chain (after 3/97).

**TABLE 2-1**

## 2.1 Debarker Frame Mounting Holes

**IMPORTANT!** Sawmills are equipped with pre-drilled Debarker mounting holes. **Verify hole locations before beginning Debarker installation. Proper hole location is imperative for safe and effective Debarker operation.**

**See Figure 2-1.** Sawmills built prior to March 1998 only have two debarker mounting holes pre-drilled in the saw head. You will need to drill an additional set of two holes at the dimensions indicated. Drill the two  $13/32$ " diameter holes through the saw head tube and the wall of the middle blade housing.

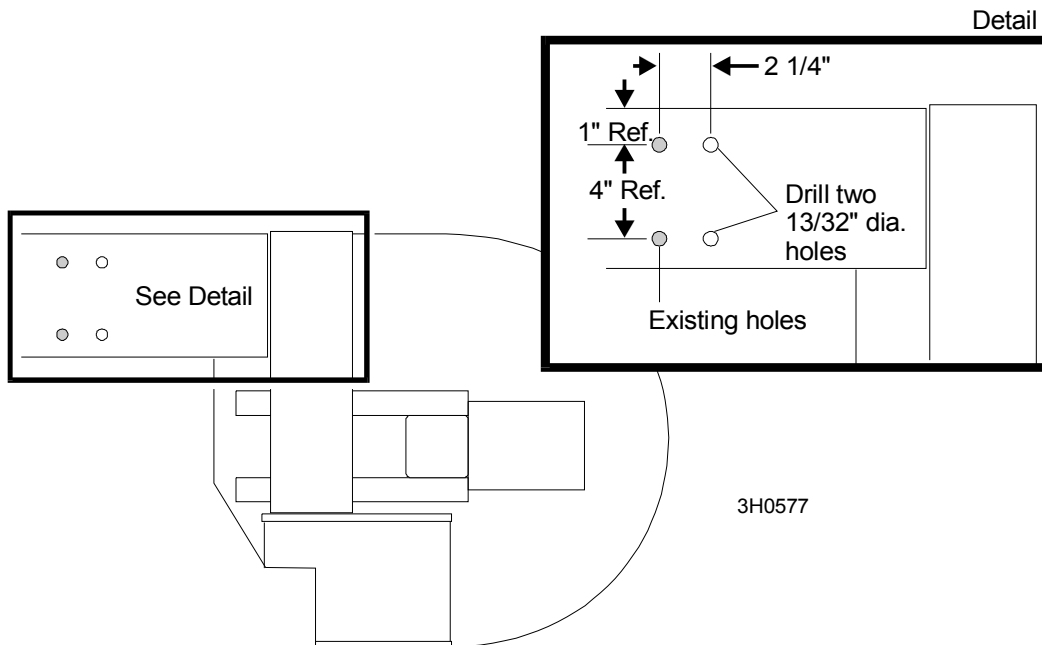

FIG. 2-1

## 2 Debarker Installation

### *Debarker Installation*

---

### 2.2 Debarker Installation

**NOTE:** You will not use all components of the debarker bag assembly during installation. Excess hardware is included to cover all possible mill variations and needs.

**See Figure 2-2.** The debarker wiring on sawmills built after 7/98 is pre-routed and secured at the debarker mounting location with a guard. This guard must be removed before the debarker can be installed.

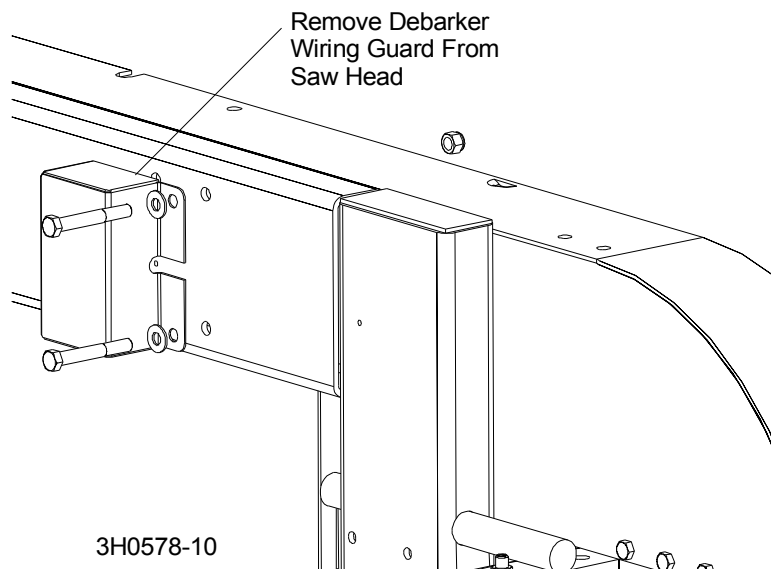

**FIG. 2-2**



1. Open the middle blade housing cover. Remove the four pre-installed bolts and nuts from the debarker frame mounting blocks.
2. Assemble the debarker to the sawmill saw head. Align the mounting block holes and the holes in the saw head. Insert the bolts from the back of the saw head, through the debarker mounting block holes. Use the lock nuts to secure in place. Tighten the mounting bolts to 20 ft.-lbs. torque. Do not tighten the set screws in the mounting blocks until debarker alignment has been performed.

**NOTE:** When installing, make sure the blade guide motor wire harness is routed between the saw head and the pivot arm.

**See Figure 2-3.**

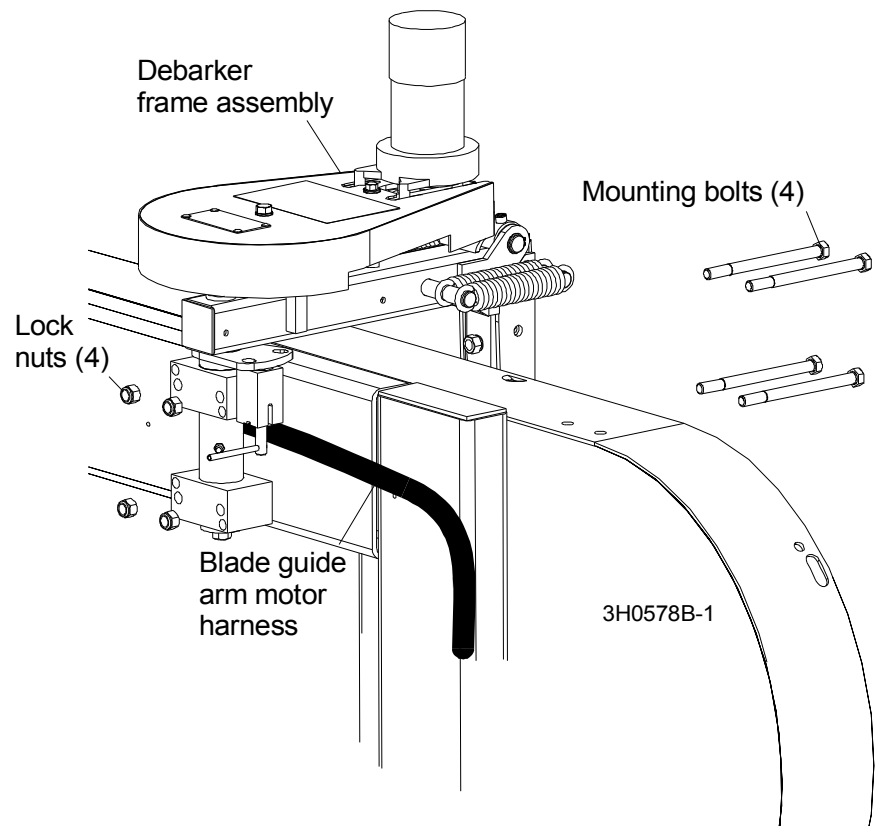

**FIG. 2-3**

## 2

### Debarker Installation

#### *Debarker Installation*

3. Assemble the debarker cutting head to the mount plate on the frame.

Use the four provided 5/16-18 x 3/4" bolts and 5/16" split lock washers to mount the cutting head to the debarker frame. Use the lower set of four holes in the head mounting plate. The upper set of holes are provided in the event the cutting head needs to be adjusted further down than the slotted motor mount holes will allow.

See Figure 2-4.

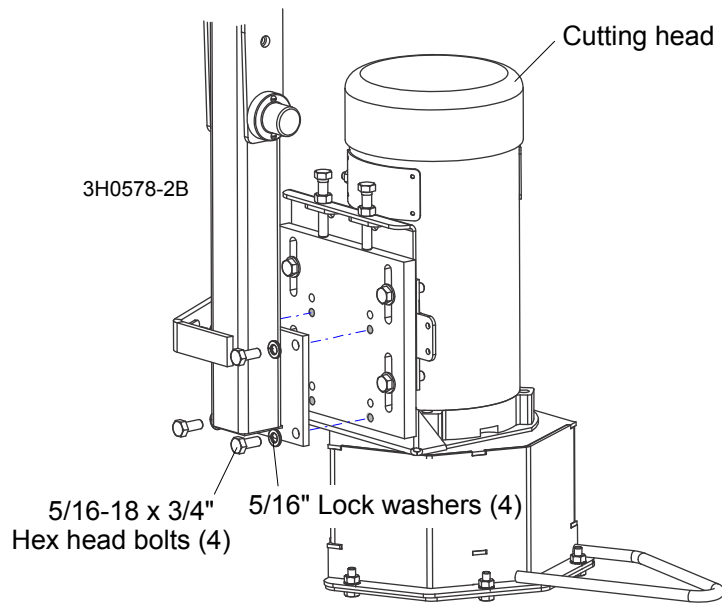

**FIG. 2-4**

- 4. Install the spring arm assembly to the debarker in/out pulley using the 3/8-16 x 1 3/4" hex head bolt, two flat washers, and two lock nuts provided.
- 5. Remove the idle-side blade housing cover. Align the two holes in the spring arm bracket with the two holes in the top of the saw head blade housing. Use the provided 3/8-16 x 1" hex head bolts and 3/8-16 nylon lock nuts to secure the spring arm bracket saw head. Replace the blade housing cover. Close the middle blade housing cover.

See Figure 2-5.

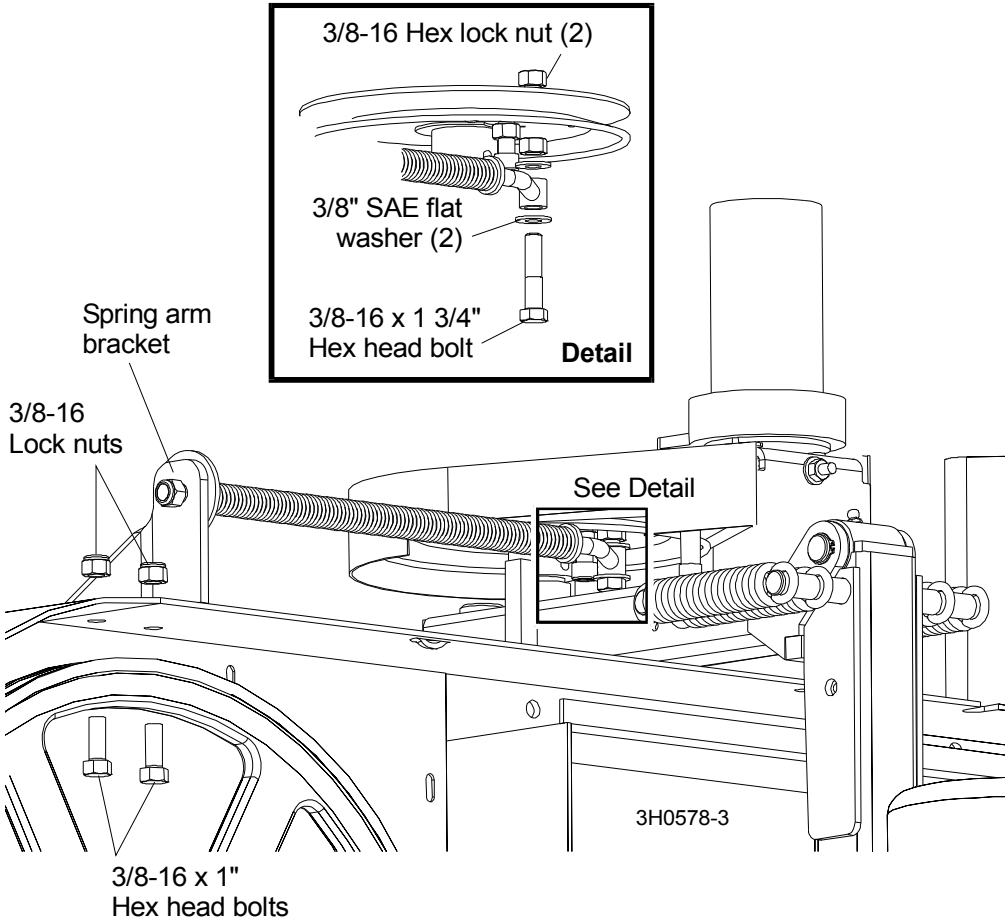

**FIG. 2-5**

# 2

## Debarker Installation

### Debarker Installation

6. Install the blade guard bracket and flexible debris guard to the debarker head with two 1/4" flat washers, lock washers, and 1/4-20 x 1" hex head bolts. Be sure the bottom of the debris guard is even with the bottom of the debarker blade.

See Figure 2-6.

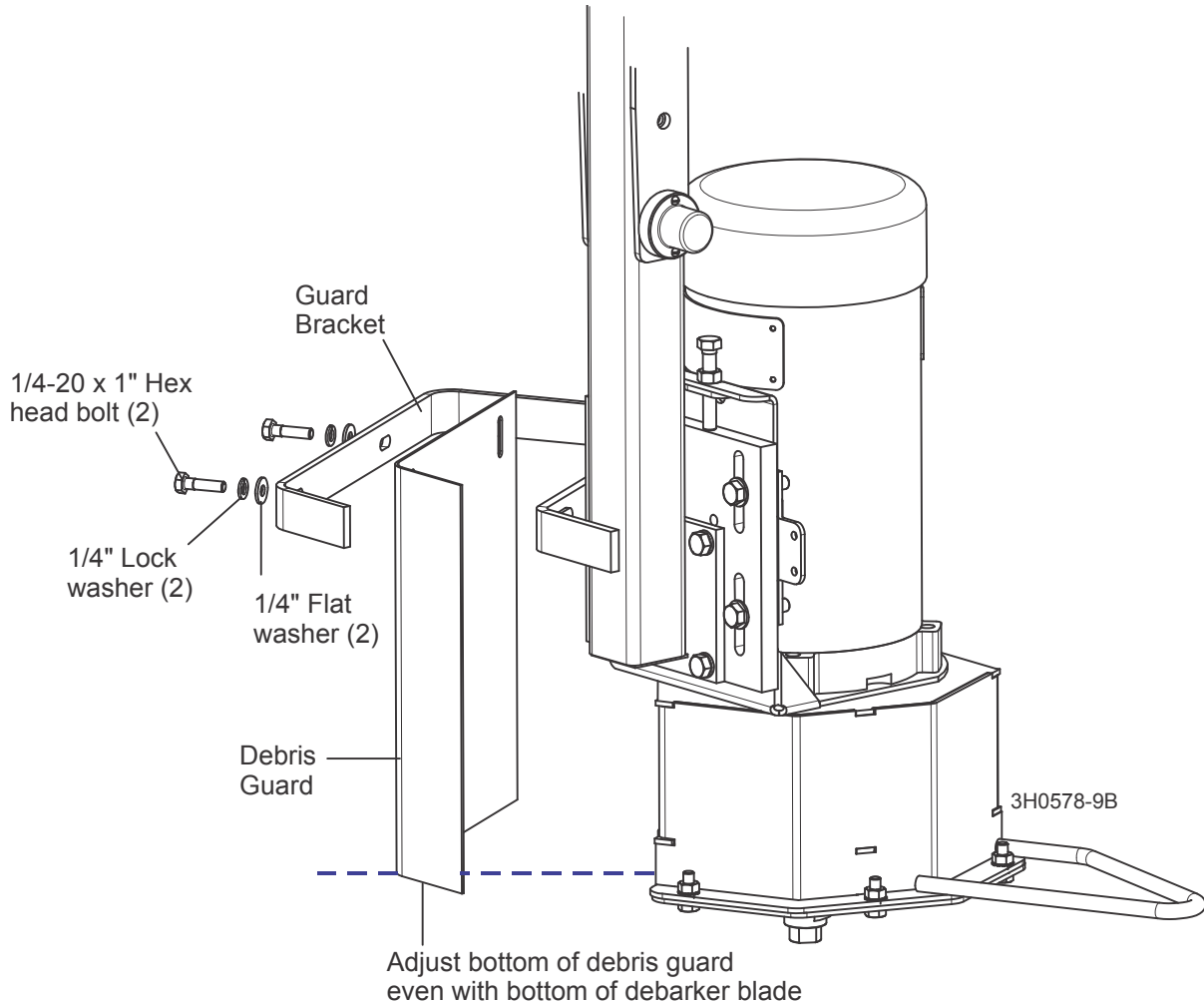

FIG. 2-6

## 2.3 Lower Harness Installation



**DANGER!** On electric mills, hazardous voltage inside the disconnect box, starter box, and at the electric motor can cause shock, burns, or death. Disconnect and lock out power! Follow all applicable electrical codes.

**DANGER!** Before performing any service to this equipment, turn the key to the OFF (0) position, remove the key, and disconnect the sawmill battery ground terminal. Failure to do so will result in serious injury or death.



**IMPORTANT!** Avoid pinch and pivot points, unnecessary wire bending and open spaces where the wire could get caught by a log, etc. If you have any questions, call Wood-Mizer customer service.

1. 1997 and newer model sawmills are pre-wired for the debarker option. On sawmills built before 7/97, the debarker wires are stored inside the drive pulley housing. On sawmills built after 7/97, the debarker wires are pre-routed and stored under a guard which is removed before debarker installation ([See Section 2.2](#)). Skip to Step 4 if your sawmill debarker wiring is pre-routed.
2. Remove the drive pulley housing and locate the wires (#21, 22, 23 & 24). The fifth wire (#25) is for the optional laser sight and should remain in place.
3. Remove the lower drive belt cover. Slide the long piece of expandable conduit over all four wires. Route the wire/conduit along the existing wiring under the sawmill engine/motor mount plate. Secure the wires in the existing clamps or use the provided wire ties to secure the new harness to the existing harnesses.
4. Route the harness between the debarker mount and saw head as shown. Continue routing the harness along the debarker frame, under the spring arm and down toward the blade motor.

# 2

## Debarker Installation

### Lower Harness Installation

See Figure 2-7.

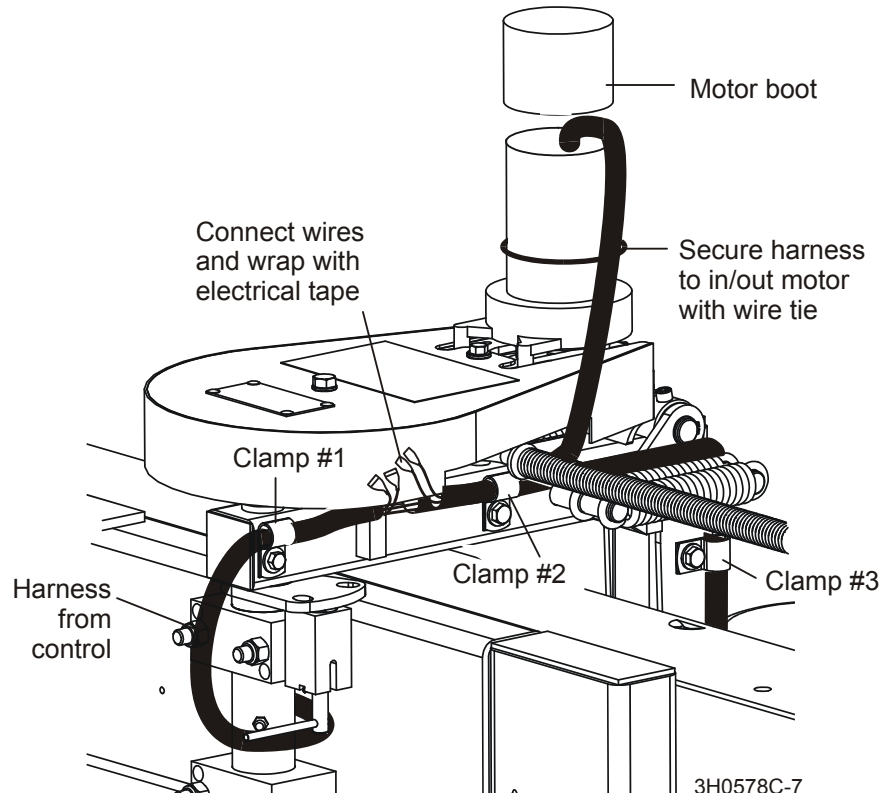

FIG. 2-7

5. Secure the harness to the debarker frame using three harness clamps, 1/4" flat washers and 1/4-20 x 1/2" hex head bolts. Be sure to leave enough slack in the harness to allow the debarker its full range of movement and also to prevent undue wire stress from sharply bent wires.
6. Remove the boot from the in/out motor. Install the short piece of conduit over the red and black in/out motor wires.
7. Route the cable underneath the spring arm, through harness clamp #2.
8. Replace the in/out motor boot and use one of the provided wire ties to secure the harness to the side of the drive motor.
9. Strip the end of the black in/out motor wire and install a provided 1/4" male quick connect terminal. Cut the red in/out motor wire so it is 1" shorter than the black motor wire, strip the end, and install a provided 1/4" male quick connect terminal. This will allow the wires to be neatly bundled together and wrapped later.

- 10.** Force a hole in the long harness conduit between clamps #1 and #2. Pull the small red wire #21 and small black wire #22 through the hole. Cut both wires if necessary so approximately 2" of wire protrudes from the harness.
- 11.** Strip the ends of both wires and install a provided female quick connect terminal to each wire.
- 12.** Connect the red in/out motor wire to the red control harness wire. Connect the black in/out motor wire to the black control harness wire. Wrap the wire connections with electrical tape.
- 13.** Route the harness and wires from the warning light (or bell prior to Rev. C.05) to the terminal posts on the blade motor.

## 2

### Debarker Installation

#### Lower Harness Installation

14. **Rev. C.05+:** Secure the warning light wires to the motor harness with a wire tie approximately 3" from the motor terminals as shown.

See Figure 2-8.

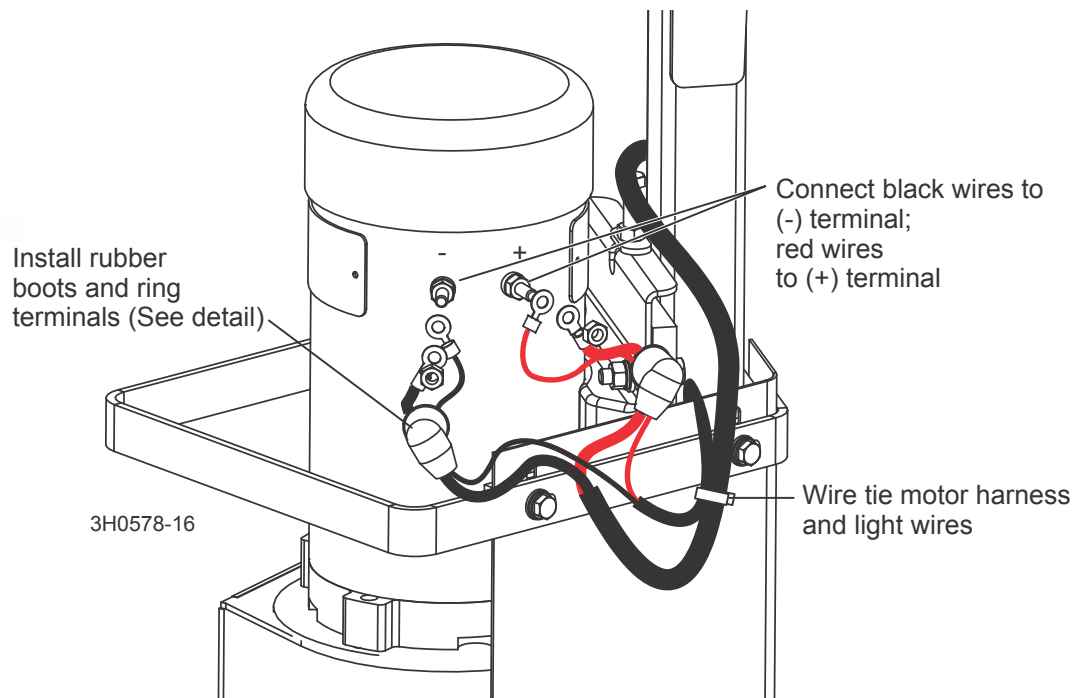

**FIG. 2-8 REV. C.05+**



15. **Prior to Rev. C.05:** Secure the warning bell wires to the motor harness with a wire tie approximately 3" from the motor terminals as shown.

See Figure 2-9.

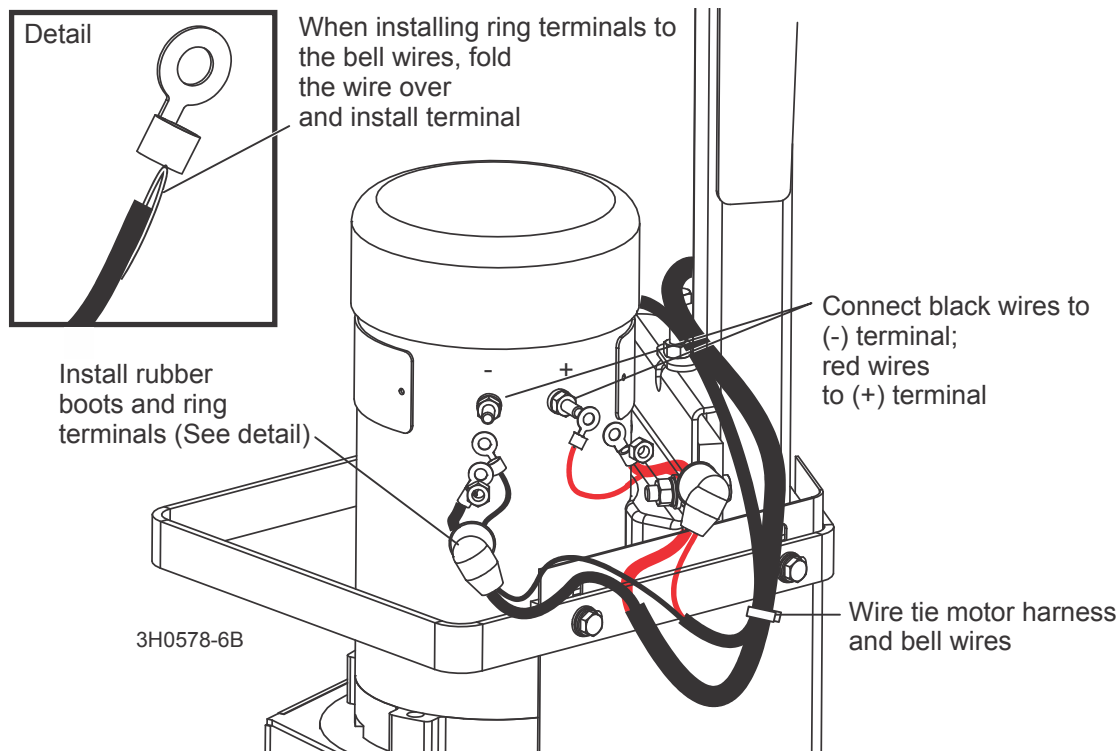

FIG. 2-9 PRIOR TO REV. C.05

16. Remove the top nuts from each of the motor terminals. The harness conduit and wires may be longer than necessary (to allow for differences in routing).
17. Route the black motor wire from the harness and the black wire from the warning light (or bell prior to **Rev. C.05**) through one of the provided rubber boots. **Prior to Rev. C.05:** Strip the end of the black motor wire and install a 1/4" 8 gauge ring terminal. Strip the end of the black warning bell wire and install a 1/4" 14-16 gauge ring terminal. To install the 14-16 gauge ring terminal, fold the stripped end of the wire over the insulation, install the ring terminal and crimp in place.
18. Connect the black motor and light wires (or bell wires prior to **Rev. C.05**) to the negative (-) motor terminal. Replace the terminal nut to secure the wires.



**IMPORTANT!** Make sure that the ring terminals do not touch the motor body.

## 2

### Debarker Installation

#### *Lower Harness Installation*

---

19. Route the red motor wire and the red wire from the warning light (or bell prior to **Rev. C.05**) through one of the provided rubber boots. **Prior to Rev. C.05:** Strip the end of the red motor wire and install a 1/4" 8 gauge ring terminal. Strip the end of the red warning bell wire and install a 1/4" 14-16 gauge ring terminal. To install the 14-16 gauge ring terminal, fold the stripped end of the wire over the insulation, install the ring terminal and crimp in place.
20. Connect the red motor and light wires (or bell wires prior to **Rev. C.05**) to the positive (+) motor terminal. Replace the terminal nut to secure the wires.



**IMPORTANT!** Make sure that the ring terminals do not touch the motor body.

21. Slide the rubber boots over the motor terminal posts to protect the connections.
22. Replace all removed covers and guards.

## 2.4 Control Component Installation (Non-Remote Mills)



**DANGER!** On electric mills, hazardous voltage inside the disconnect box, starter box, and at the electric motor can cause shock, burns, or death. Disconnect and lock out power! Follow all applicable electrical codes.

**DANGER!** Before performing any service to this equipment, turn the key to the OFF (0) position, remove the key, and disconnect the sawmill battery ground terminal. Failure to do so will result in serious injury or death.

[See Section 2.5](#) if assembling the Debarker option to a sawmill equipped with the remote operation option. [See SECTION 5](#) for the appropriate wiring diagram to aid in installation.

1. Remove the side, front and rear panels (leave wire connections) from the control box.
2. Locate the solenoid mounting studs in the control box. Place the solenoid on the mounting studs and place the diode assembly ring terminal over one of the studs. Use the two 1/4-20 self-locking nuts provided to secure in place.

See Figure 2-10.

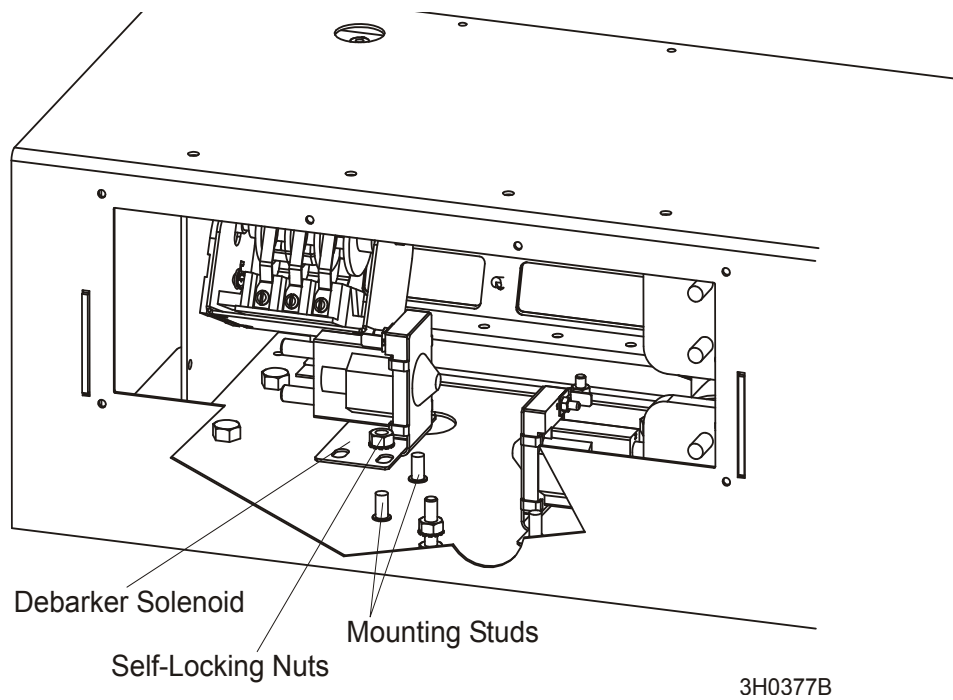

FIG. 2-10

## 2

### Debarker Installation

#### Control Component Installation (Non-Remote Mills)

3. Remove the two small bolts and nuts and the one large bolt and nut from the back of the control box.
4. Locate the bundle of wires on the floor of the sawmill control box. Make sure the large black #24 wire is connected to the rear ground stud. Connect the large red #23 wire to the empty terminal on the provided 70 amp breaker. Do not overtighten this connection. Overtightening could cause component breakage.
5. Install the 70 amp breaker and rubber boot to the large hole on the back of the control box. Be sure the breaker terminals do not touch any other components or wires inside the control box.
6. Install the provided 15 amp breaker to the two small holes in the back of the control box (position the breaker so the reset tab is near the rear opening of the control box). Use the existing screws and nuts (removed earlier) to secure in place.

See Figure 2-11.

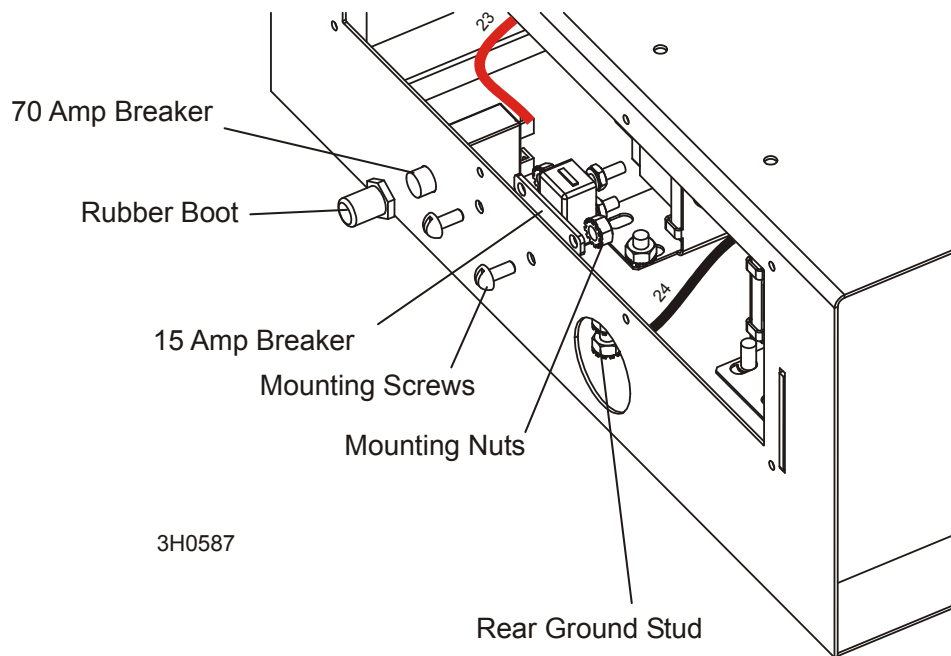

**FIG. 2-11** STANDARD (ALL) & SUPER (BEFORE 9/04)

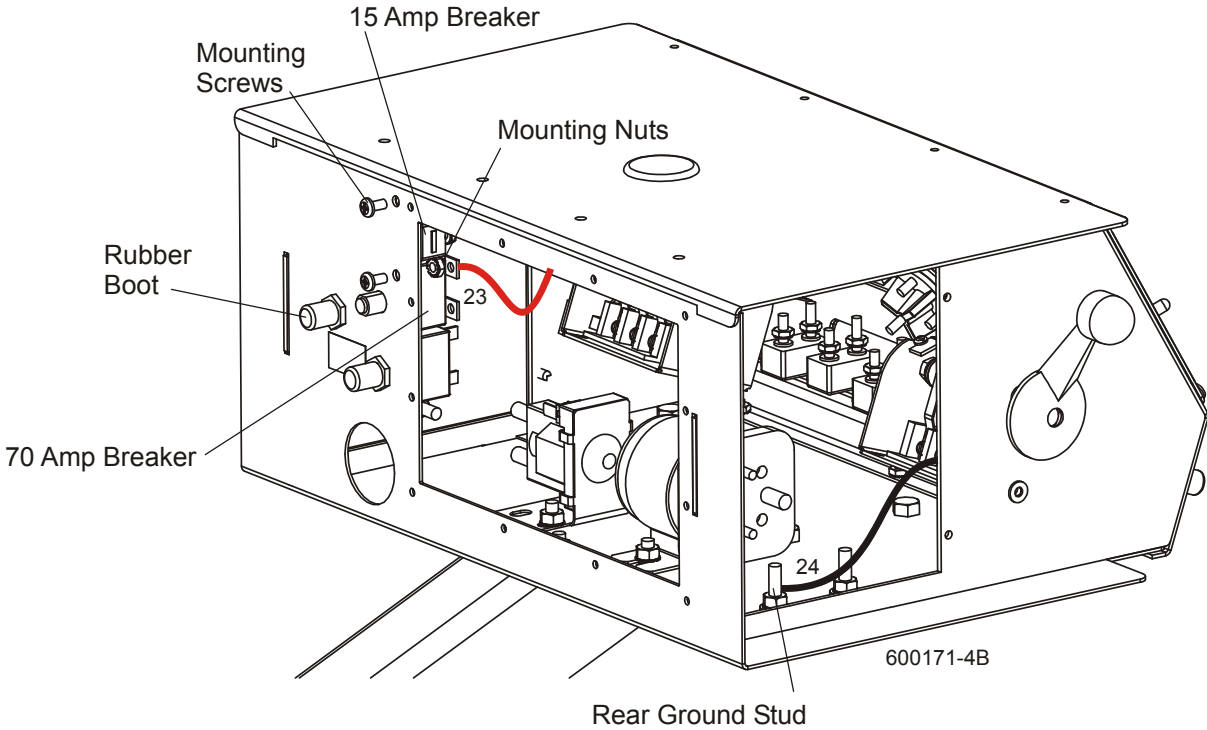

FIG. 2-11SUPER (AFTER 9/04)

## 2

### Debarker Installation

#### Control Component Installation (Non-Remote Mills)

- Using the back side of the front panel for a guideline, cut out holes in the front panel lexan decal for the debarker switches. Install the provided toggle switches, 1/16" nylon washers, and rubber boots in place as shown.

See Figure 2-12.

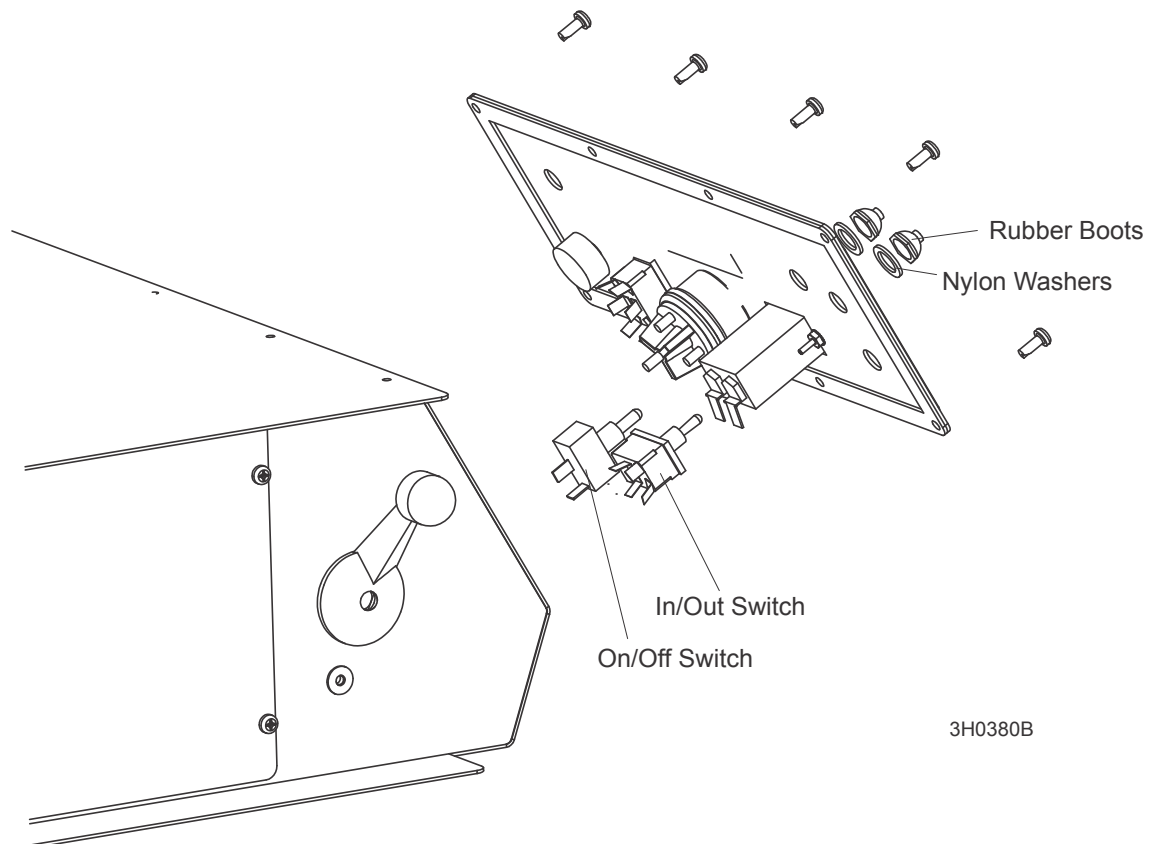
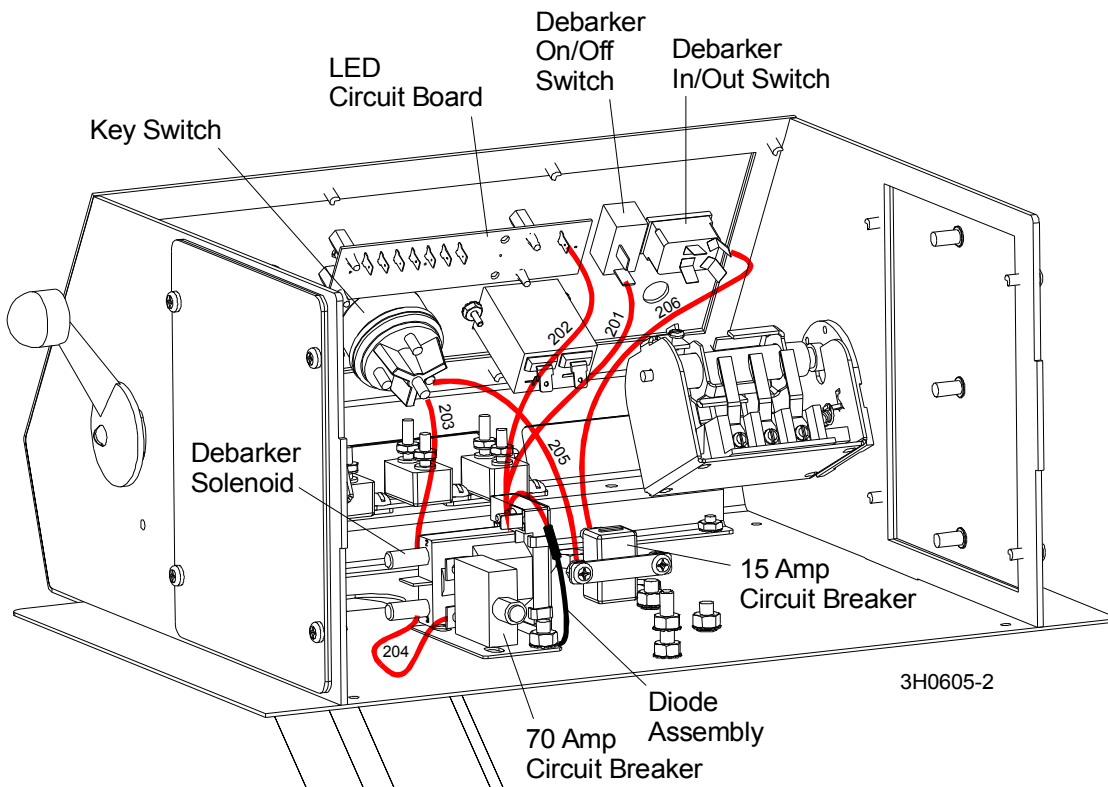

FIG. 2-12

8. Connect the red #205 wire from the 15 amp breaker to the ACC post on the key switch.
9. Make sure the red #206 wire from the 15 amp breaker to the debarker in/out switch is connected.
10. Connect the red #202 wire from the debarker solenoid to the DBKR terminal on the LED board. **NOTE:** If the control box is not equipped with the LED board, remove the red #202 wire from the debarker solenoid.
11. Make sure the red #201 wire from the small terminal on the debarker solenoid to the debarker on/off switch is connected.
12. Connect the red #203 wire from debarker solenoid to the BAT post of the key switch.
13. Make sure the red #204 wire from the bottom debarker solenoid terminal to the 70 Amp breaker is connected.

**See Figure 2-13.** Box housing removed for clarity. Only wires referred to above are shown. Standard control box shown, Super model control differs slightly.



**FIG. 2-13**

## 2

### Debarker Installation

#### Control Component Installation (Non-Remote Mills)

14. Connect the red #200 wire from the debarker on/off switch to the sawmill control:

**LT40HD-H Hydro Models:** Connect red wire #200 to the existing short red wire connected to relay L13 mounted on the back of the control box. Use the provided #10 screw, washer and lock nut to connect the wires. Wrap the connection with the provided piece of rubber tubing and secure with a tie wrap.

**LT40HD Super/LT50HD Wireless Models:** Connect red wire #200 to the existing short red wire connected to terminal #T13 of the wireless interface control board. Use the provided #10 screw, washer and lock nut to connect the wires. Wrap the connection with the provided piece of rubber tubing and secure with a tie wrap.

**Super Models between 9/04 and 7/10:** Connect red wire #200 to the existing short red wire connected to terminal #3 of the power feed drum switch. Use the provided #10 screw, washer and lock nut to connect the wires. Wrap the connection with the provided piece of rubber tubing and secure with a tie wrap.

**All Standard Models & Super Models before 9/04 and after 8/10:** Connect red wire #200 to terminal #2 of the power feed drum switch. **NOTE:** Some sawmills are equipped with a short red wire connected to terminal #2 of the power feed drum switch. If so, connect debarker wire #200 to the end of the short wire with the provided #10 screw, washer and lock nut. Wrap the connection with the provided piece of rubber tubing and secure with a tie wrap. If no short wire exists, connect debarker wire #200 directly to power feed drum switch terminal #2.

See Figure 2-14.

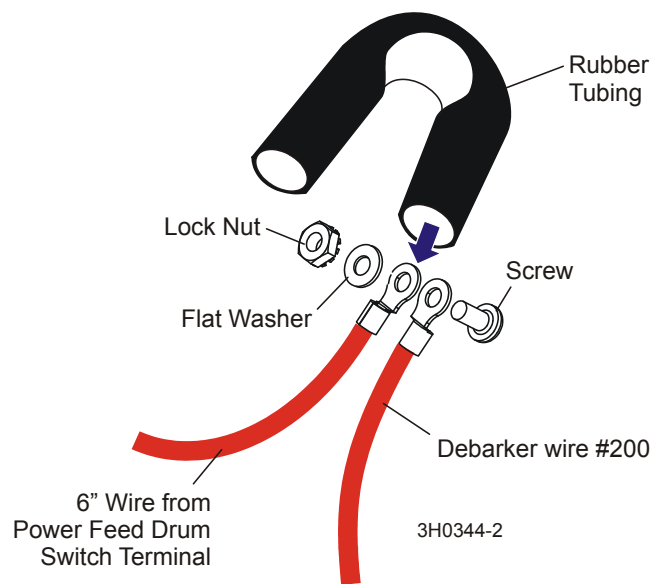
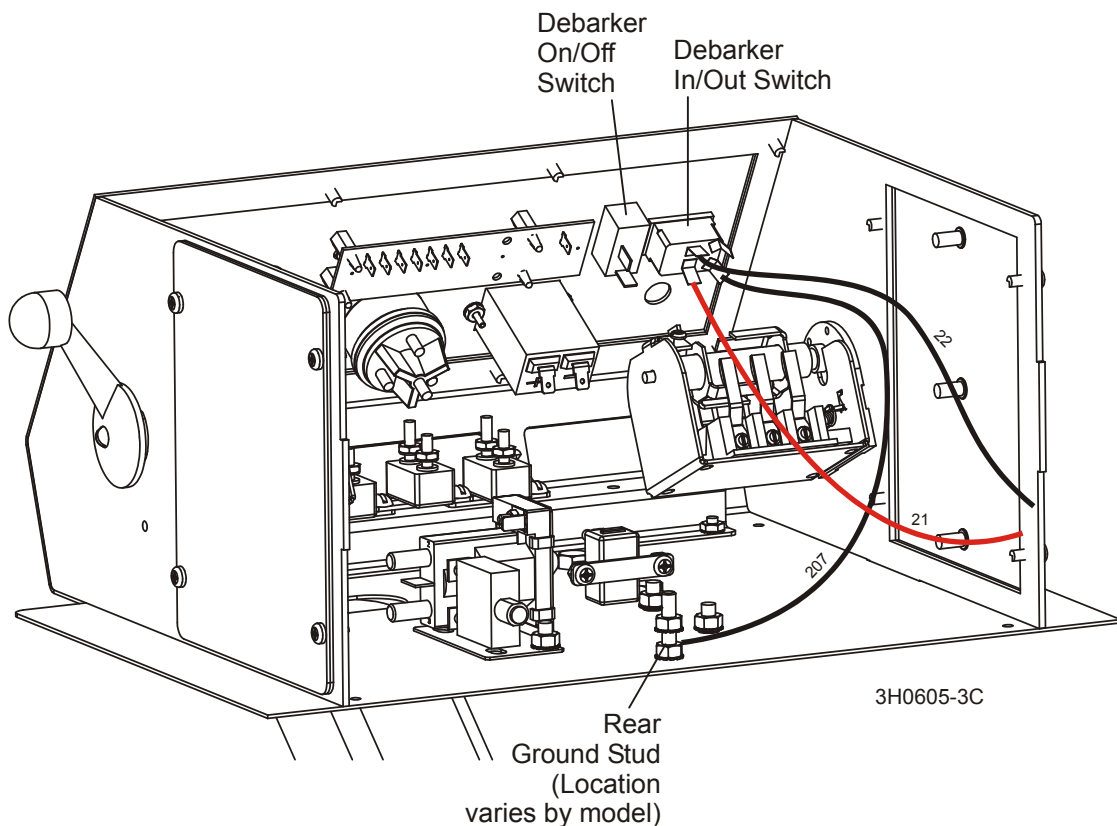

FIG. 2-14



15. Connect the black #207 wire from the debarker in/out switch to the rear ground stud.
16. Locate the bundle of wires on the floor of the sawmill control box. Make sure the debarker in/out switch is oriented horizontally as shown.
17. Connect the small red #21 wire to the debarker in/out switch bottom left terminal.
18. Connect the small black #22 wire to the debarker in/out switch top left terminal.

**See Figure 2-15.** Box housing removed for clarity. Only wires referred to above are shown. Standard control box shown, Super model control differs slightly.



**FIG. 2-15**

19. Reinstall the front and rear panels, side panel, and control box top cover to the control box.

## 2.5 Control Component Installation (Remote Mills)



**DANGER!** On electric mills, hazardous voltage inside the disconnect box, starter box, and at the electric motor can cause shock, burns, or death. Disconnect and lock out power! Follow all applicable electrical codes.

**DANGER!** Before performing any service to this equipment, turn the key to the OFF (0) position, remove the key, and disconnect the sawmill battery ground terminal. Failure to do so will result in serious injury or death.

[See Section 2.4](#) if assembling the Debarker option to a sawmill not equipped with the remote operation option. [See SECTION 5](#) for a complete wiring diagram to aid in installation.

### ***Remote Power Box Component Installation***

See **Figure 2-16**.

1. Open the remote power junction box door.
2. Install the debarker solenoid next to the existing solenoid with the two bolts and nuts provided in the bottom of the box. Place the diode ring terminal over one of the solenoid mounting bolts before securing with the nuts.
3. Locate the large red #23 wire in the remote power box and connect it to the empty terminal on the provided 70 Amp breaker. Do not overtighten this connection. Overtightening could cause component breakage.
4. Remove the bolt and nut from the hole in the side of the remote power box and install the 70 Amp breaker and rubber boot to the hole. Be sure the breaker terminals do not touch any other components or wires inside the control box.
5. Make sure the large black #24 wire is connected to the side ground stud.
6. Locate the small red #33 wire from connector J2 terminal #18. Connect it to the small, top terminal on the debarker solenoid.
7. Connect large red #203 wire from the large bottom terminal of the debarker solenoid to the accessory solenoid:

**100A Solenoid before 5/03:** Connect red wire #203 to the large bottom terminal.

**200A Solenoid after 5/03:** Connect red wire #203 to the large terminal closest to the debarker solenoid.

Only wires referred to above are shown.

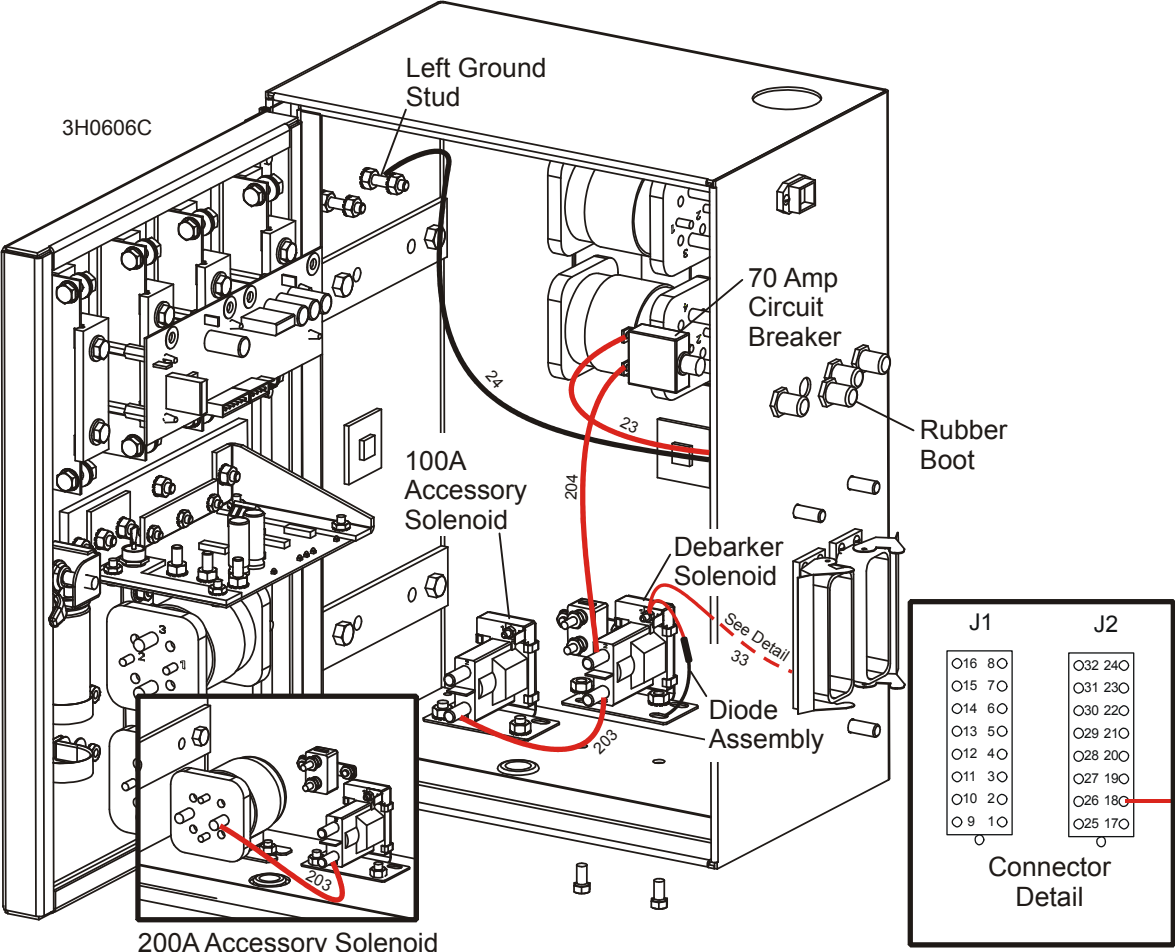

FIG. 2-16

- 8. Close the remote power box door. Engage the door latch and tighten with a hex key to properly seal the box.

## 2

### Debarker Installation

#### Control Component Installation (Remote Mills)

##### Sawmill Control Box Component Installation

9. Remove the rear panel from the sawmill control box (leave wire connections).
10. Remove the two small bolts and nuts from the back of the control box.
11. Install the provided 15 Amp breaker to the two small holes in the back of the control box (reset tab up). Replace the screws and nuts to secure the breaker to the back panel.

See Figure 2-17.

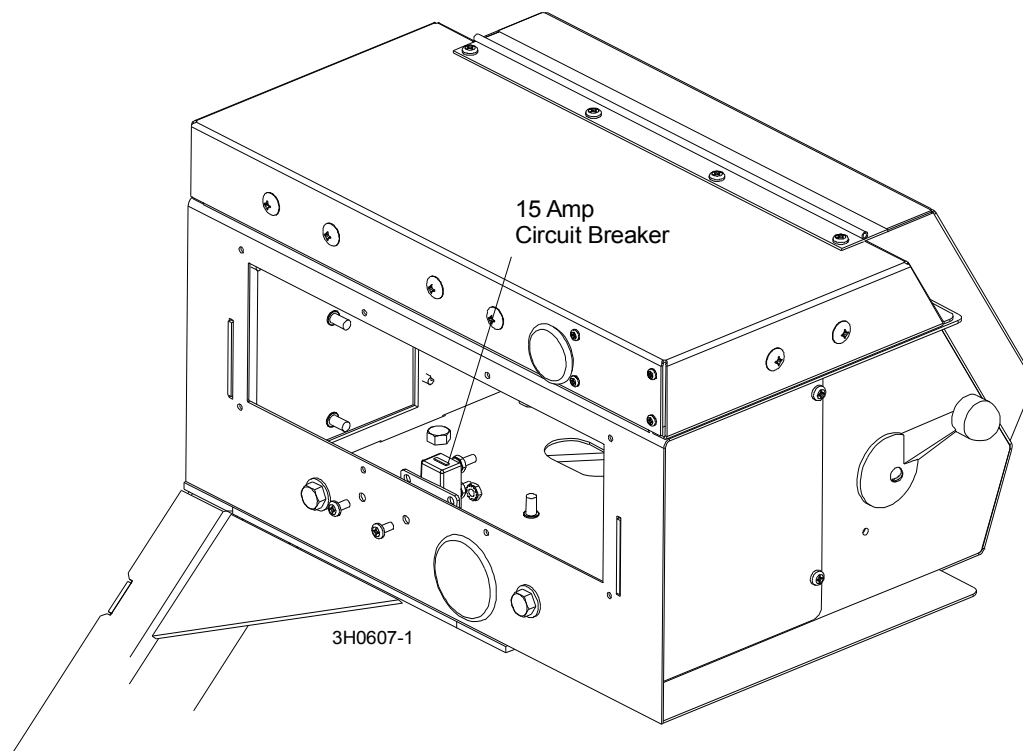

FIG. 2-17

12. Using the back side of the front panel for a guideline, cut out holes in the front panel lexan decal for the debarker switches. Install the provided toggle switches, 1/16" nylon washers, and rubber boots in place as shown.

See Figure 2-18.

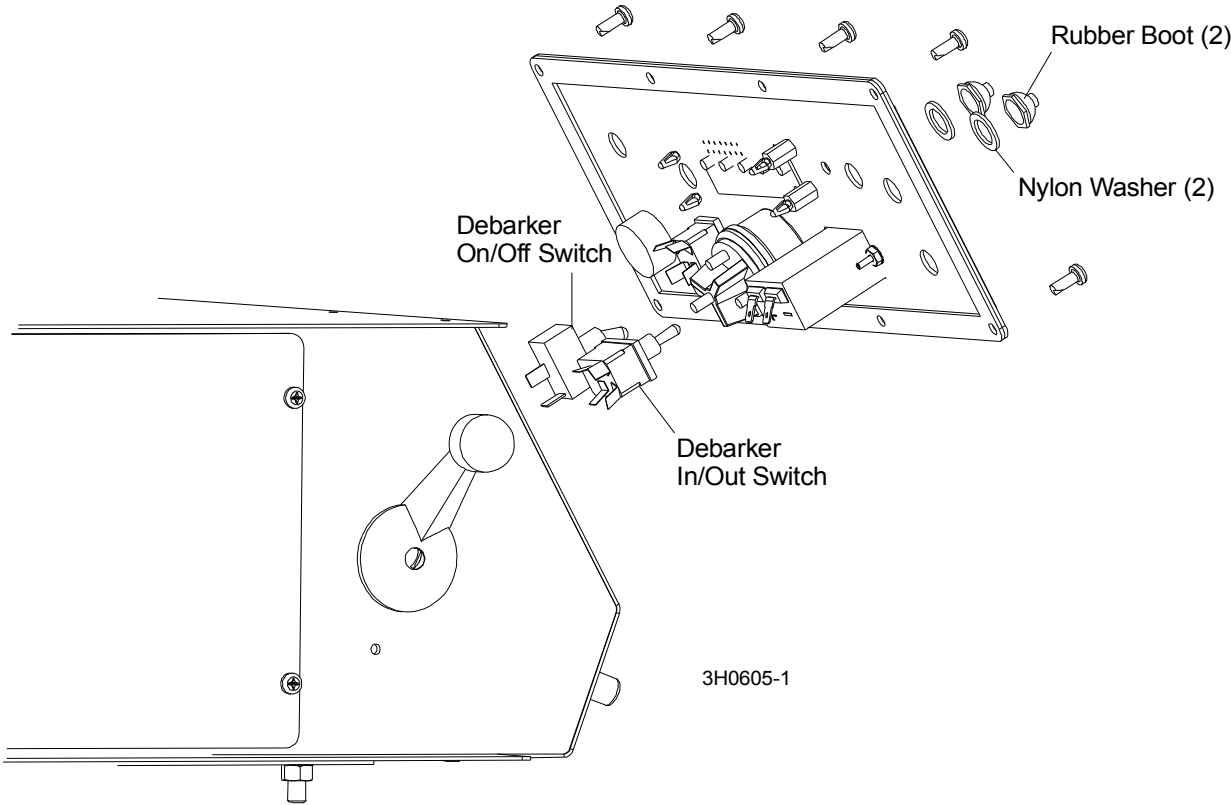

FIG. 2-18

## 2

### Debarker Installation

#### Control Component Installation (Remote Mills)

13. Connect the red #205 wire from the 15 Amp breaker to the ACC post on the key switch.
14. Make sure the red #206 wire from the 15 Amp breaker to the debarker in/out switch is connected.
15. Connect the red #208 wire from the debarker on/off switch to the DBKR terminal on the LED board. **NOTE:** If the control box is not equipped with the LED board, remove the red #208 wire from the debarker on/of switch.

**See Figure 2-19.** Box housing removed for clarity. Only wires referred to above are shown.

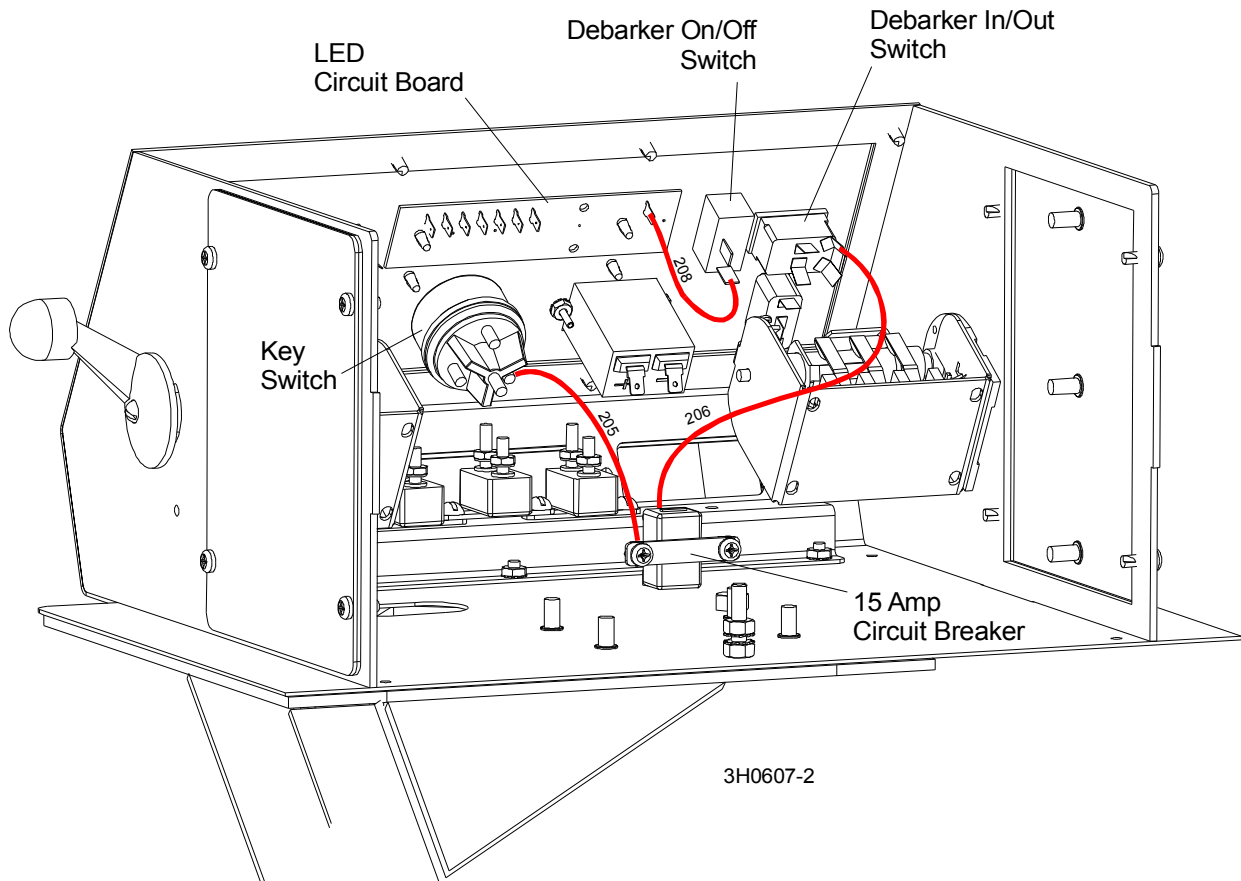

**FIG. 2-19**

16. Connect the red #200 wire from the debarker on/off switch to the power feed drum switch.

**Super Models after 9/04:** Connect red wire #200 to the existing short red wire connected to terminal #3 of the power feed drum switch. Use the provided #10 screw, washer and lock nut to connect the wires. Wrap the connection with the provided piece of rubber tubing and secure with a tie wrap.

**All Standard Models & Super Models before 9/04:** Connect red wire #200 to terminal #2 of the power feed drum switch. **NOTE:** Some sawmills are equipped with a short red wire connected to terminal #2 of the power feed drum switch. If so, connect debarker wire #200 to the end of the short wire with the provided #10 screw, washer and lock nut. Wrap the connection with the provided piece of rubber tubing and secure with a tie wrap. If no short wire exists, connect debarker wire #200 directly to power feed drum switch terminal #2.

See Figure 2-20.

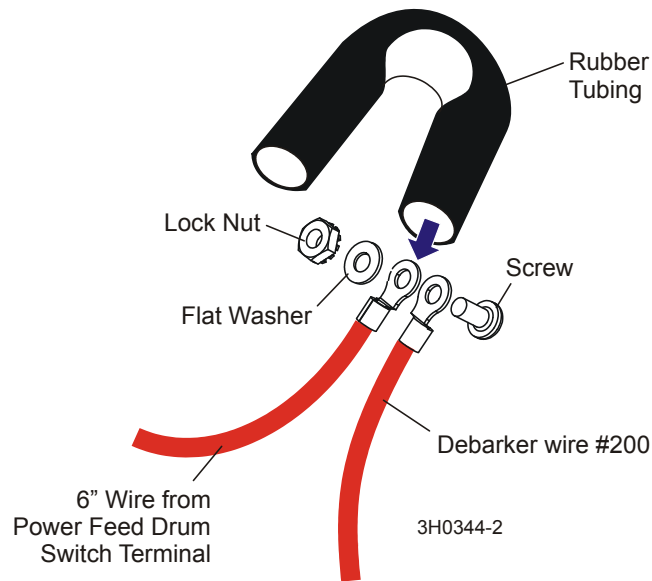

FIG. 2-20

## 2

### Debarker Installation

#### Control Component Installation (Remote Mills)

17. Connect the black #207 wire from the debarker in/out switch to the rear ground stud.
18. Locate the bundle of wires on the floor of the sawmill control box. Make sure the debarker in/out switch is oriented horizontally as shown.
19. Connect the small red #21 wire to the debarker in/out switch bottom left terminal.
20. Connect the small black #22 wire to the debarker in/out switch top left terminal.
21. Connect the small red #33 wire to the male terminal extension on the debarker on/off switch bottom terminal.
22. Reinstall the control box panels.

See Figure 2-21.

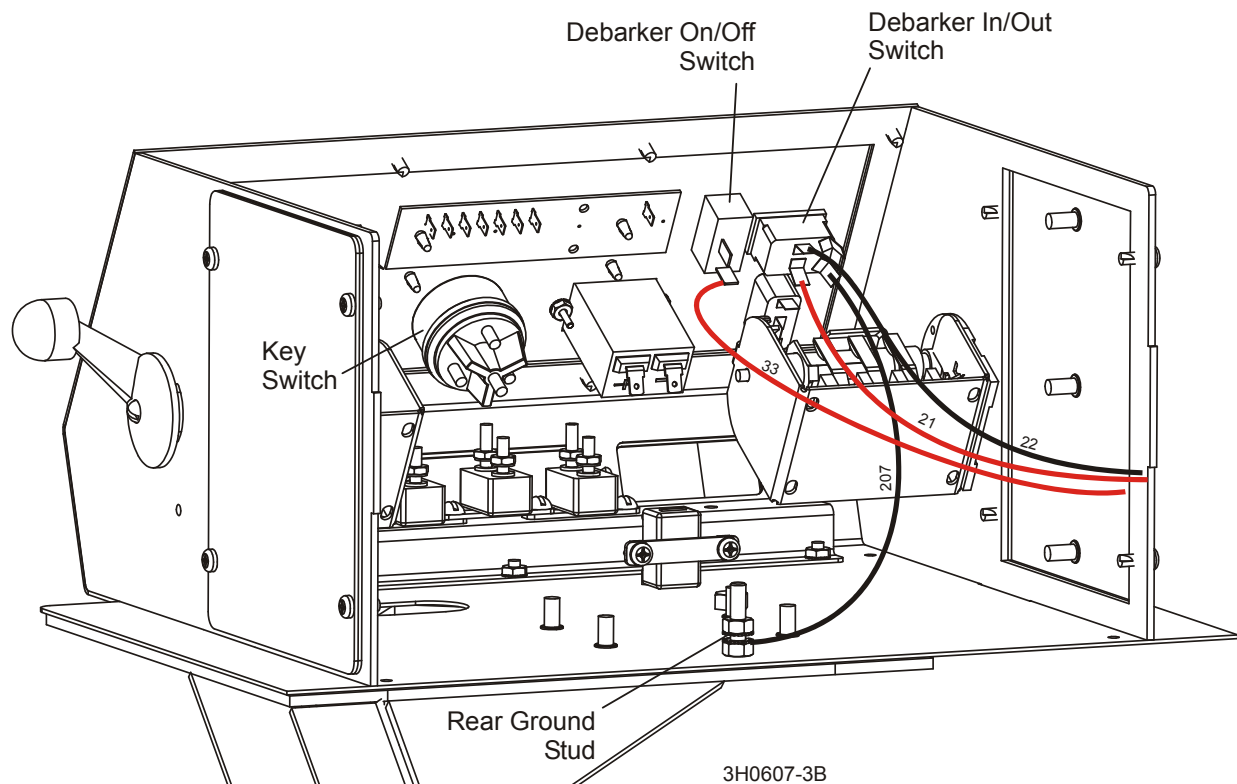

FIG. 2-21



## SECTION 3 ALIGNMENT



**DANGER!** Before performing any service to this equipment, turn the key to the OFF (0) position and remove the key. Failure to do so will result in serious injury or death.

The debarker blade should be aligned to the sawmill blade to insure proper operation. The debarker blade should be parallel with and aligned vertically with the sawmill blade.

1. Turn the key to ACC (3) and use the debarker in/out switch to move the debarker all the way in. Turn the key to OFF (0) and remove the key. This will prevent the debarker from being turned on while performing alignment procedures.
2. Check the squareness of the debarker with the sawmill blade. Adjust the debarker mounts if necessary until the debarker is square with the sawmill blade.

Loosen the four debarker mounting bolts and use a mallet to adjust the mounting blocks. The mounting holes are oversized to allow small adjustments of the debarker. Tilt the debarker mount until the debarker is square with the sawmill blade.

Reighten the debarker mounting bolts to 20 ft.-lbs. torque. Tighten the two set screws in the mounting block holes to secure the debarker in its aligned position.

### 3 Debarker Installation

See Figure 3-1.

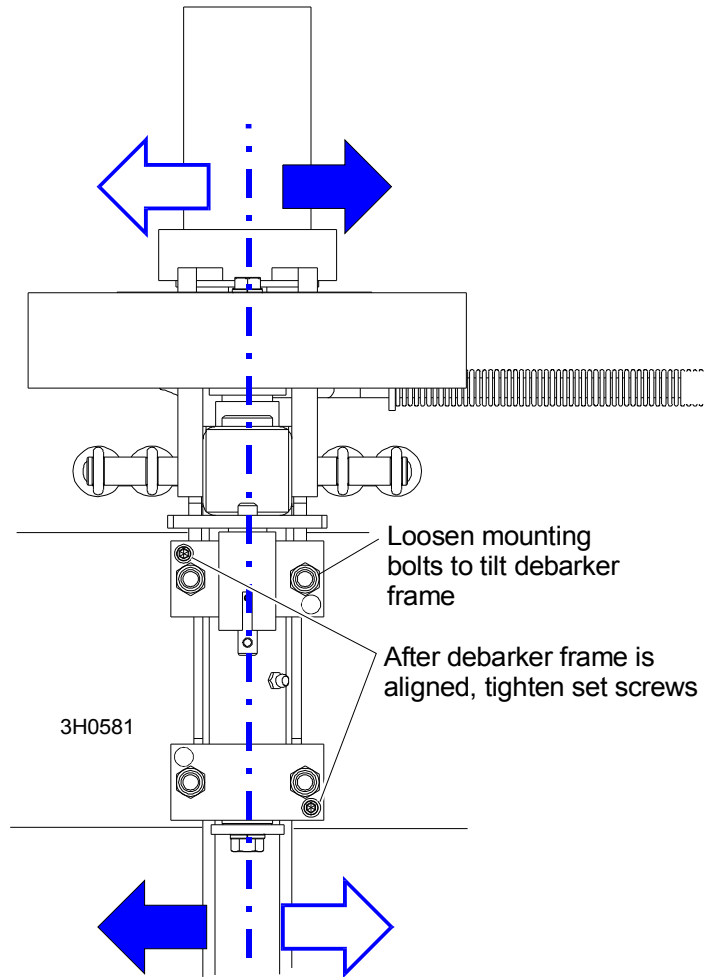

**FIG. 3-1**

3. Clip the blade guide alignment tool to the sawmill blade. Make sure the tool lies flat on the blade and does not contact a tooth that could cause it to angle.

See Figure 3-2.

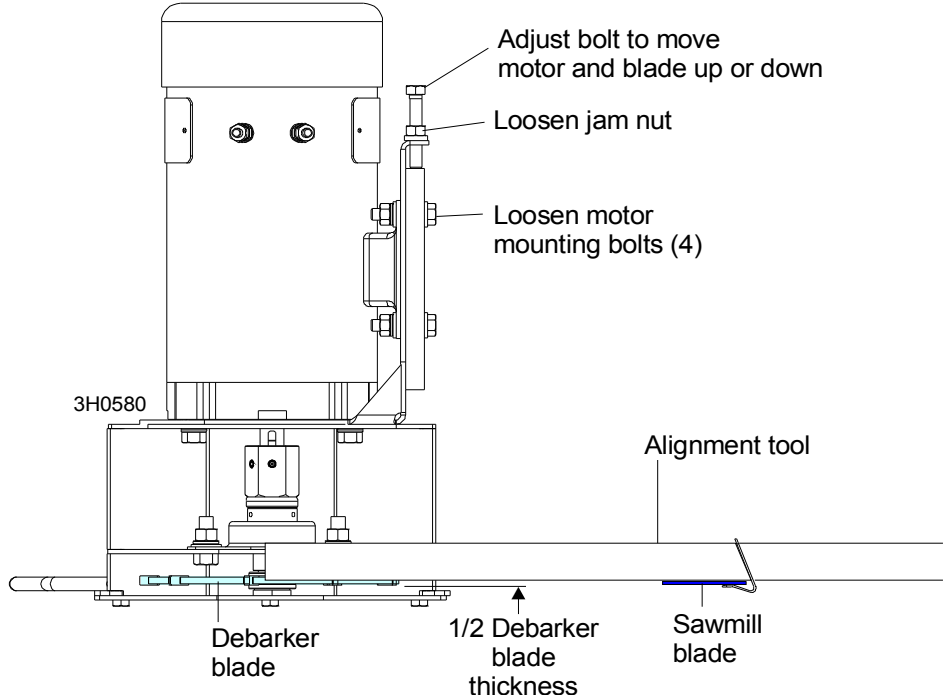

FIG. 3-2

- 4. Check the height of the debarker blade against the alignment tool. The bottom edge of the tool should align with the center of the debarker blade.

To adjust the blade up or down, loosen the four blade motor mount bolts. Loosen the jam nut on the adjustment bolt. Turn the adjustment bolt clockwise to push the motor and blade down. Turn the adjustment bolt counterclockwise and slide the motor up to raise the motor and blade. Retighten the adjustment bolt jam nut and four motor mount bolts.

- 5. Insert the key and use the debarker in/out switch to move the debarker all the way out. Turn the key to OFF (0) and remove the key.
- 6. Move the blade guide alignment tool on the sawmill blade and check the position of the debarker blade against the tool. If the debarker blade is not centered with the tool, readjust the debarker mounting bolts to adjust the debarker assembly parallel to the blade.

## SECTION 4 OPERATION AND MAINTENANCE

### 4.1 Locking Pin Operation

**See Figure 4-1.** The debarker is equipped with a locking pin located where the debarker frame pivots in the mounting blocks. Three hole locations are provided for the locking pin. The inner two holes should be used to lock the debarker in place when towing the sawmill. Use the innermost hole if traveling without any options on the sawmill bed. Use the middle hole if traveling with an optional Shingle/Lap Siding or Resaw Attachment option. The outer position can be used to hold the debarker out of the way when debarking is not required during sawing.

**NOTE:** Debarkers before Rev. C.04 do not have the middle lock pin hole. Use the inner hole for travel and the outer hole for holding the debarker out of the way when not in use.

**Before operating the debarker,** make sure the locking pin is secured in its disengaged position. Turn the key switch to OFF (0) and remove the key. Pull the debarker out to relieve pressure on the locking pin. Pull the pin down and rotate so the small roll pin is aligned with the disengaged position slot. Release the locking pin.

**Before towing the sawmill,** lock the debarker in the travel position. Turn the key switch to ACC (3) and use the debarker in/out switch to move the debarker all the way in. Turn the key to OFF (0) and remove the key. Push the debarker in until the desired travel position hole aligns with the locking pin. Pull the pin down and rotate until the small roll pin is aligned with the engaged position slot. Release the locking pin.

**To move the debarker out of the way during sawing,** turn the key switch to ACC (3) and use the debarker in/out switch to move the debarker all the way out. Turn the key to OFF (0) and remove the key. Push the debarker out until the outer hole is aligned with the locking pin. Pull the pin down and rotate until the small roll pin is aligned with the engaged

position slot. Release the locking pin.

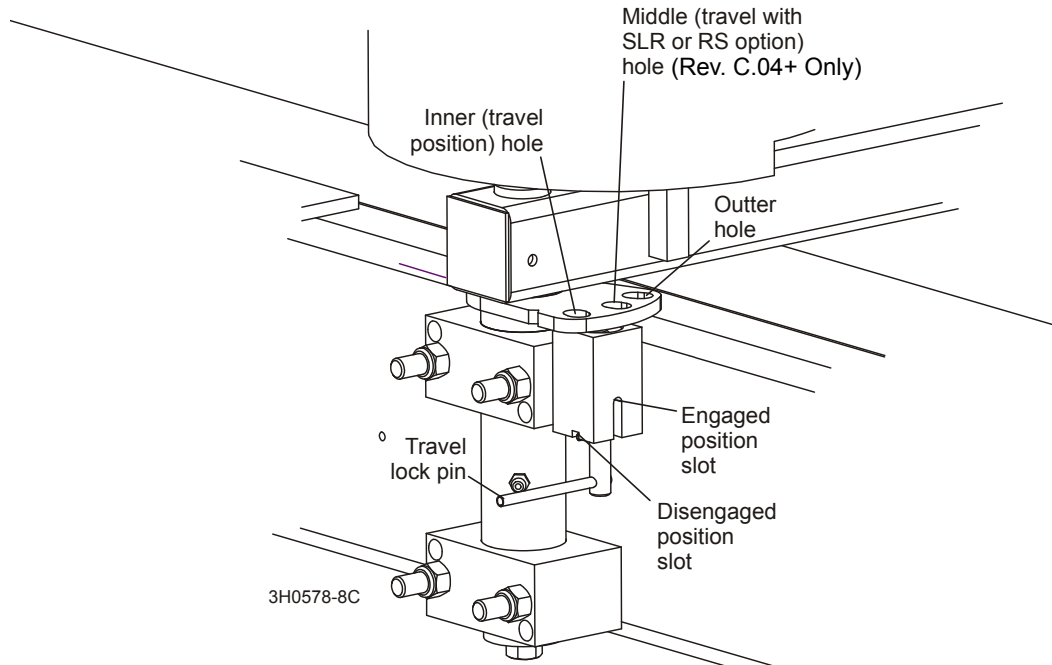
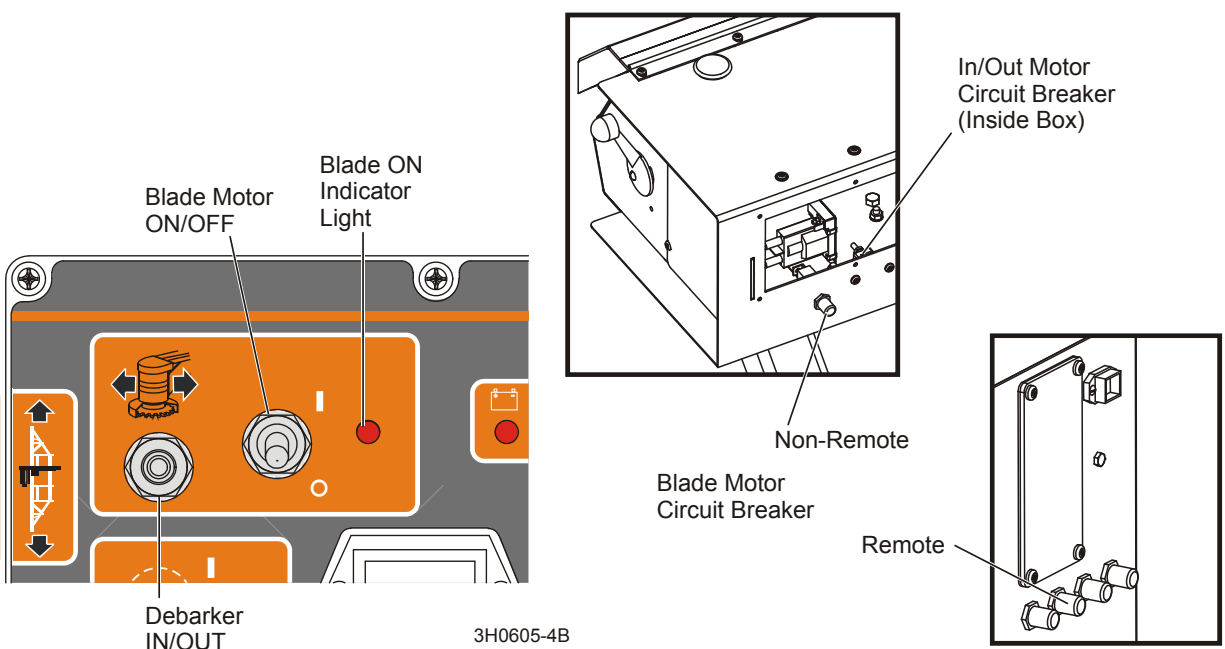

FIG. 4-1

## 4.2 Control Overview

The Debarker Option allows you to remove bark from logs ahead of the bandsaw blade. This prevents the bandsaw blade from contacting dirt, sand, or other debris in the bark that can dull the blade.

See **Figure 4-2**. The debarker control includes two toggle switches, an indicator light, and circuit breakers with manual reset.



**FIG. 4-2**

- The Debarker IN/OUT toggle switch controls the debarker in/out motor to move the debarker cutting head toward or away from the log. The sawmill key switch must be on before the in/out function can be performed. **NOTE:** The distance between the debarker blade and the side support with the cutting head all the way in is 6" (150mm) for the sawmill equipped with the standard head and 12" (300mm) for the sawmill equipped with the wide head.
- The Blade Motor ON/OFF toggle switch turns the blade motor on to start the debarker blade. The sawmill key switch must be on and the sawmill power feed drum switch must be activated in the forward direction before the blade motor can be turned on.
- The Blade ON indicator light comes on whenever the debarker blade motor is on.

- **Non-Remote Sawmills:** The blade motor circuit breaker can be reset by pushing the boot-covered tab on the back of the control box.
- **Remote Sawmills:** The blade motor circuit breaker can be reset by pushing the boot-covered tab on the side of the remote power box.

### 4.3 Operation



**DANGER!** Make sure all guards and covers are in place and secured before operating the debarker option. Failure to do so may result in serious injury.

**DANGER!** Keep all persons out of the path of moving equipment when operating the debarker. Failure to do so will result in serious injury.

1. Remove the blade motor cover before operating the debarker.
2. Make sure the warning light is on when the debarker is turned on.



**WARNING!** Debarker is ON when warning light is on. DO NOT disconnect the warning light. Doing so may result in serious injury.

3. Use the in/out switch on the control box to pivot the debarker all the way out.



4. Move the sawmill carriage forward and pivot the debarker in until the front fence engages with the end/side of the log.
5. Turn the debarker on/off switch to ON (1).



6. Proceed with cutting. The actuator will keep the debarker against the side of the log. Depending on log shape, you may have to pivot the debarker in and out for smooth cutting.



**NOTE:** The debarker can continuously remove up to approximately 1" of material from the log; no motor cool down time is required. Slower feed rates may be required for optimal debarker operation.

7. Once the carriage is past the end of the log, pivot the debarker away from the log. Return the carriage.





**IMPORTANT!** Should the carriage be returned before the debarker has been pivoted out of the way of the log, the debarker is designed to pivot upwards. If this happens, continue to **SLOWLY** return the carriage; or stop, pivot the debarker out and then return the carriage. **DO NOT** move the carriage forward while the debarker is contacting the log without the blade spinning.

8. When done sawing and ready to store or transport the sawmill, replace the debarker blade motor cover. Place the debarker in its travel position before towing the sawmill ([See Section 4.1](#)).

## 4.4 Maintenance



**DANGER!** Before performing any service to this equipment, turn the key to the OFF (0) position and remove the key. Failure to do so will result in serious injury or death.

1. Lubricate the two or three pivot joints with a NLGI #2 grade lithium grease every 40 hours of operation (third fitting added to travel pin block 11/07).

See Figure 4-3.

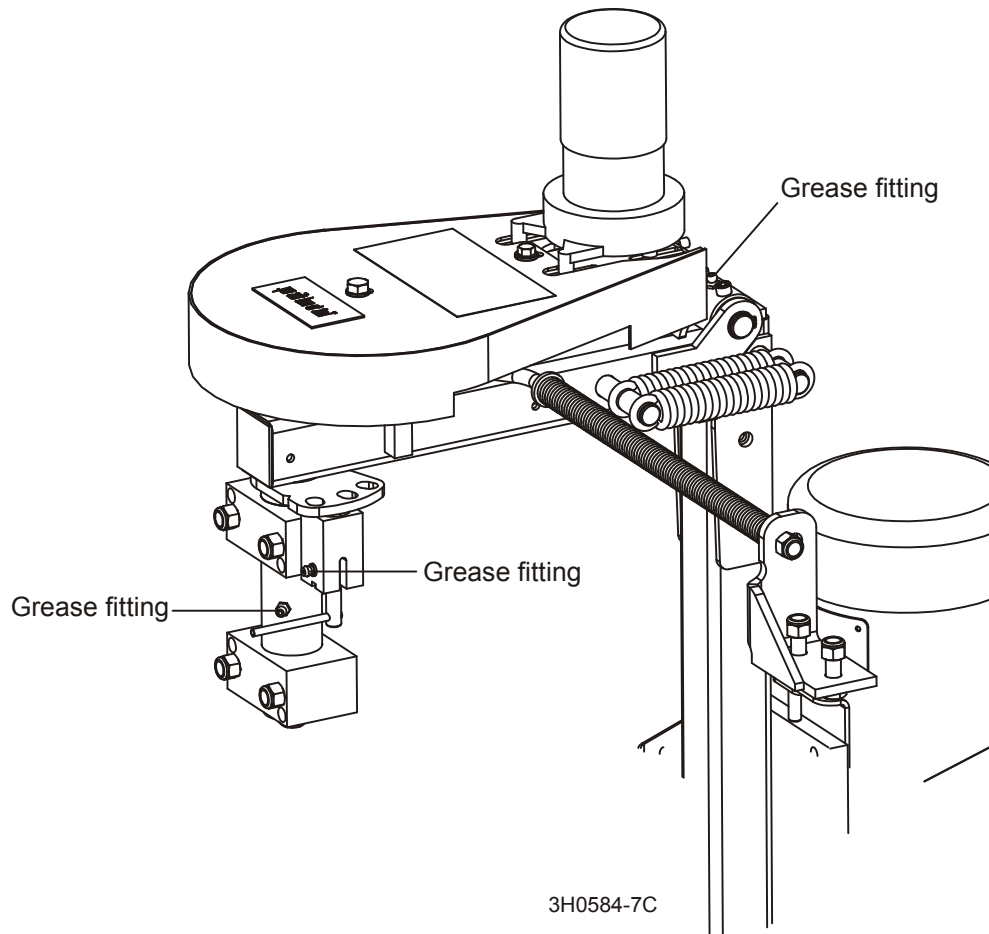

**FIG. 4-3**

2. Periodically check the flexible guard. Adjust the guard up or down so the bottom is even with the bottom of the debarker blade. Replace the guard as needed.

3. Periodically check the debarker blade. Align or replace as needed.



**WARNING!** Before replacing the debarker blade, move the sawmill blade guide arm in front of the sawmill blade to cover the blade teeth. Failure to do so may result in serious injury or death.

To replace the debarker blade, remove the lower blade guard plate. Place one wrench on the blade arbor, above the blade bearing. Place the other wrench on the lower bolt and rotate clockwise (bolt has left-hand threads). Remove the bolt and washer. Remove the blade and spacer.

Reinstall the spacer with the new blade. Reinstall the bolt and washer and turn counter-clockwise to tighten to 35 foot-pounds ( $\pm 5$ ). Reinstall the blade guard plate.



**CAUTION!** Tighten the blade bolt manually. Using power-assisted tools may result in over-torquing and damage to the bolt.

# 4

## Operation & Maintenance

### Maintenance

4. Periodically check belt for tension and wear. Adjust or replace as necessary. To tighten the belt, turn the key switch to OFF (0) and remove the key. Remove the belt guard and loosen the four motor mount screws. Turn the adjustment nut clockwise to move the motor out and tighten the belt. The belt should be tensioned to allow  $3/8$ " deflection measured halfway between the pulleys with 3-5 lbs. of force. Retighten the motor mount screws and replace the belt guard.

See Figure 4-4.

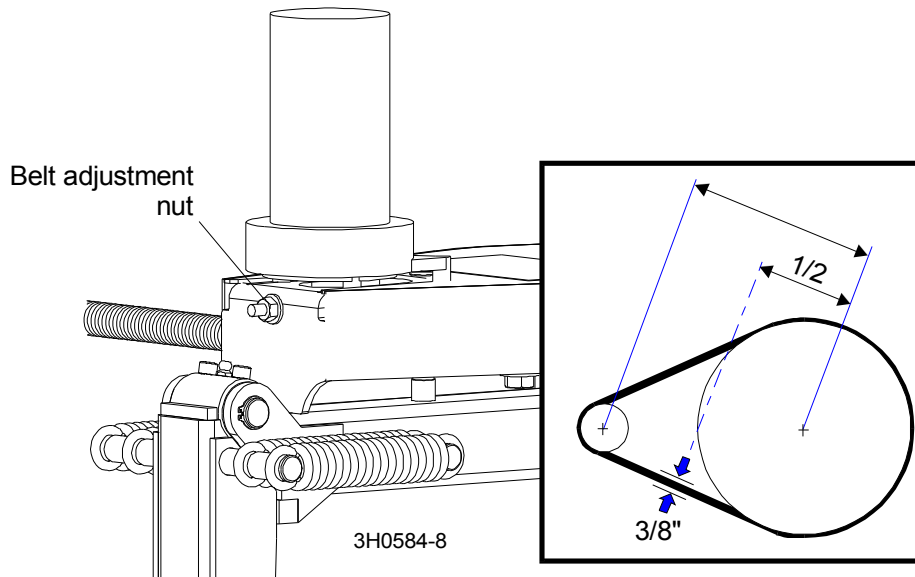

FIG. 4-4

5. Apply a dry lubricant such as Teflon spray or silicon to the spring rod and spring every 40 hours of operation.

## 4.5 Troubleshooting



**DANGER!** Before performing any service to this equipment, turn the key to the OFF (0) position, remove the key, and disconnect the sawmill battery ground terminal. Failure to do so will result in serious injury or death.

PROBLEM	CAUSE	SOLUTION
<b>70 amp circuit breaker tripping</b>	Wood or bark jammed in blade guard	Turn key to OFF position, remove key. Remove wood or bark from blade guard
	Pivot pin is binding.	Inspect for bind by moving debarker head to full in position. Turn key to OFF position, remove key. Pull arm to full out position by hand. If available, use a weight scale to pull arm to full out position. Should not have more than 12 pounds of resistance to pull out. Ensure pivot pin has been greased properly. Check pivot clamps for correct installation. Loosen pivot clamp bolts slightly, check for reduced binding
	Ring terminal of red wire touching debarker motor housing at motor	Move terminal away from motor housing. Reset circuit breaker and retest.
<b>Light comes on, but debarker motor and warning light (or horn prior to C.05) do not operate</b>	Circuit breaker weak from repeated tripping.	Replace circuit breaker
	Circuit breaker tripped	Reset circuit breaker.
<b>Debarker shuts off, but the circuit breaker is not tripped.</b>	Bad ignition wire connection	Check ignition wire connection outside and inside of debarker control box.
	Intermittent key switch	Replace key switch
	Other loose wiring connection	Check wiring connections inside control box.
<b>Debarker will not shut off. IN/OUT Motor does not move IN or OUT</b>	Solenoid is stuck closed.	Replace solenoid.
	Drive belt too loose	Tighten enough to allow movement. DO NOT OVER-TIGHTEN.
	Switch not working properly	Check wiring to switch for loose connections. If wiring looks OK, replace switch.

## SECTION 5 ELECTRICAL INFORMATION

### 5.1 Electrical Symbol Diagram (Non-Remote)

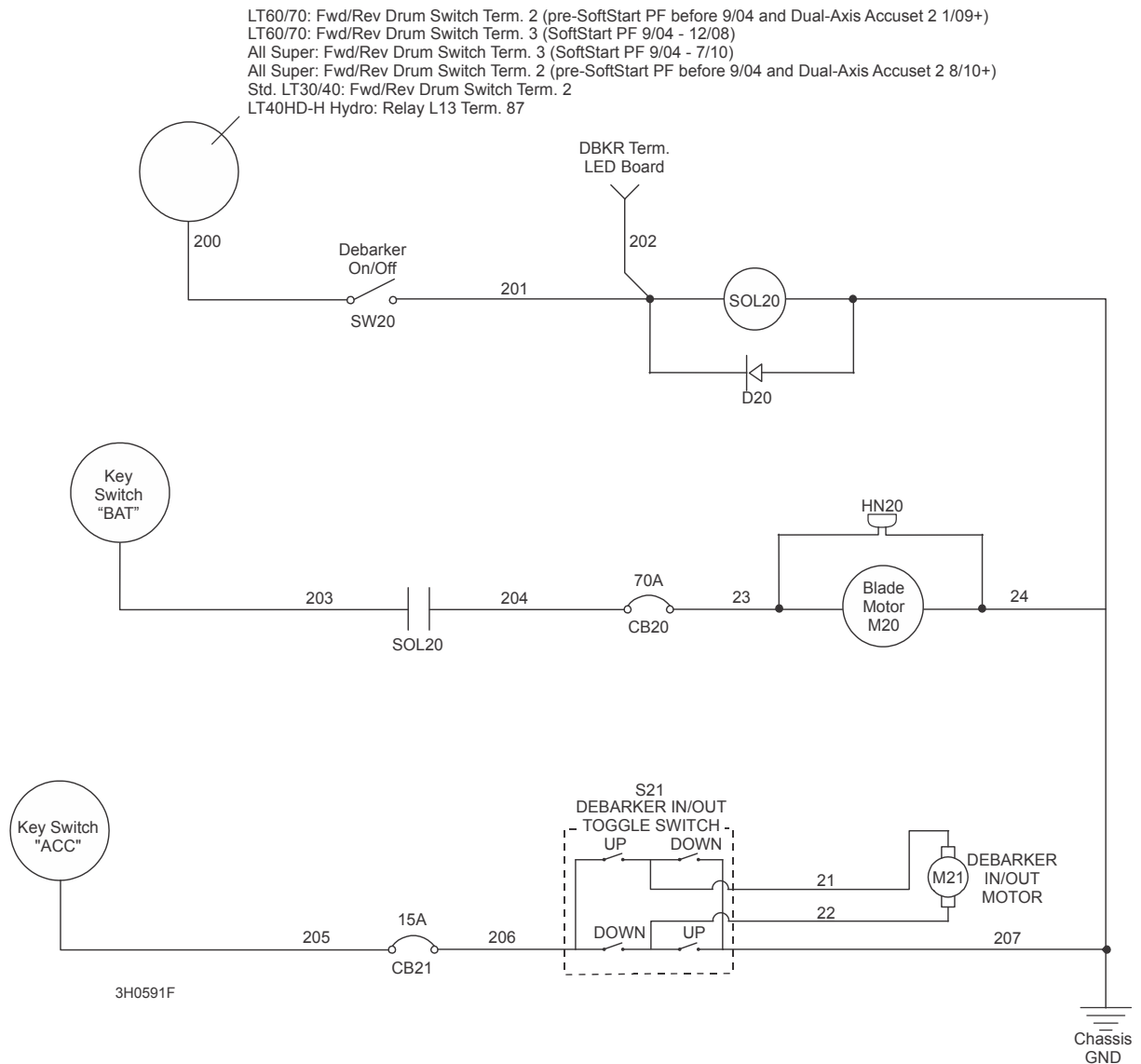

**FIG. 5-1 NON-REMOTE SAWMILL**

## 5.2 Electrical Symbol Diagram (Remote)

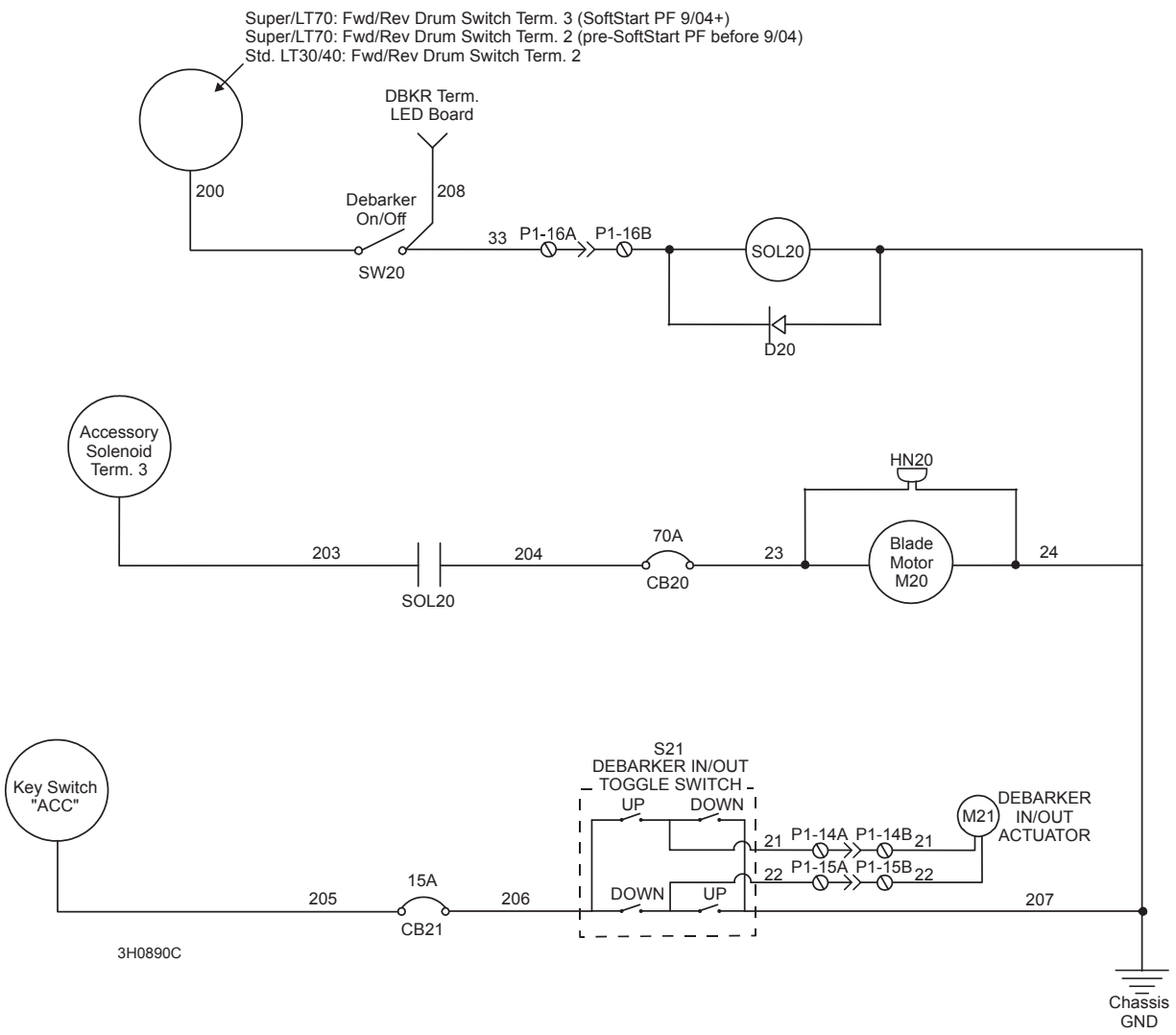

**FIG. 5-2 REMOTE SAWMILL**

### 5.3 Electrical Component List

ID	Wood-Mizer Part No.	Description
CB20	015527	Breaker, 70 A Manual Reset Panel Mount Circuit
CB21	E20430	Breaker, 15 Amp
D20	015426	Diode Assembly, Solenoid Coil Chassis
HN20	073555	Light Assembly, Debarker ON Warning Strobe (Rev. C.05+)
HN20	021137	Horn, Debarker ON Warning (Prior to Rev. C.05+)
M20	023688 <sup>1</sup>	Motor, 12 V DC 3/4HP TEFC W/Base 7/8" Dia. Shaft
	015174 <sup>1</sup>	Motor, 12 V DC 3/4HP TEFC W/Base 5/8" Dia. Shaft
M21	P09698-1	Motor, 53:1 Gear
SOL20	016372 <sup>2</sup>	Solenoid, 12V 100A Cont Duty GND Coil
SW20	P03027	Switch, Toggle
SW21	024200	Switch, DPDT Toggle

<sup>1</sup> 023688 Motor with 7/8" shaft replaces 015174 Motor with 5/8" dia. shaft (Rev. B.00). To upgrade Rev. A.00 Debarker with new motor requires new mandrel 023689.

<sup>2</sup> Solenoid Kit 016372 replaces Solenoid P10449. Kit includes solenoid and replacement instructions.



### 5.4 Electrical Wiring Diagram (non-Remote Sawmills)

LT40 Super Rev. J7.05+  
 LT30HD/40HD Super Rev. K3.04+  
 LT50HD Rev. A5.04+

This diagram applies to non-Remote Super model sawmills built after 8/10 with dual-axis Accuset 2 system.

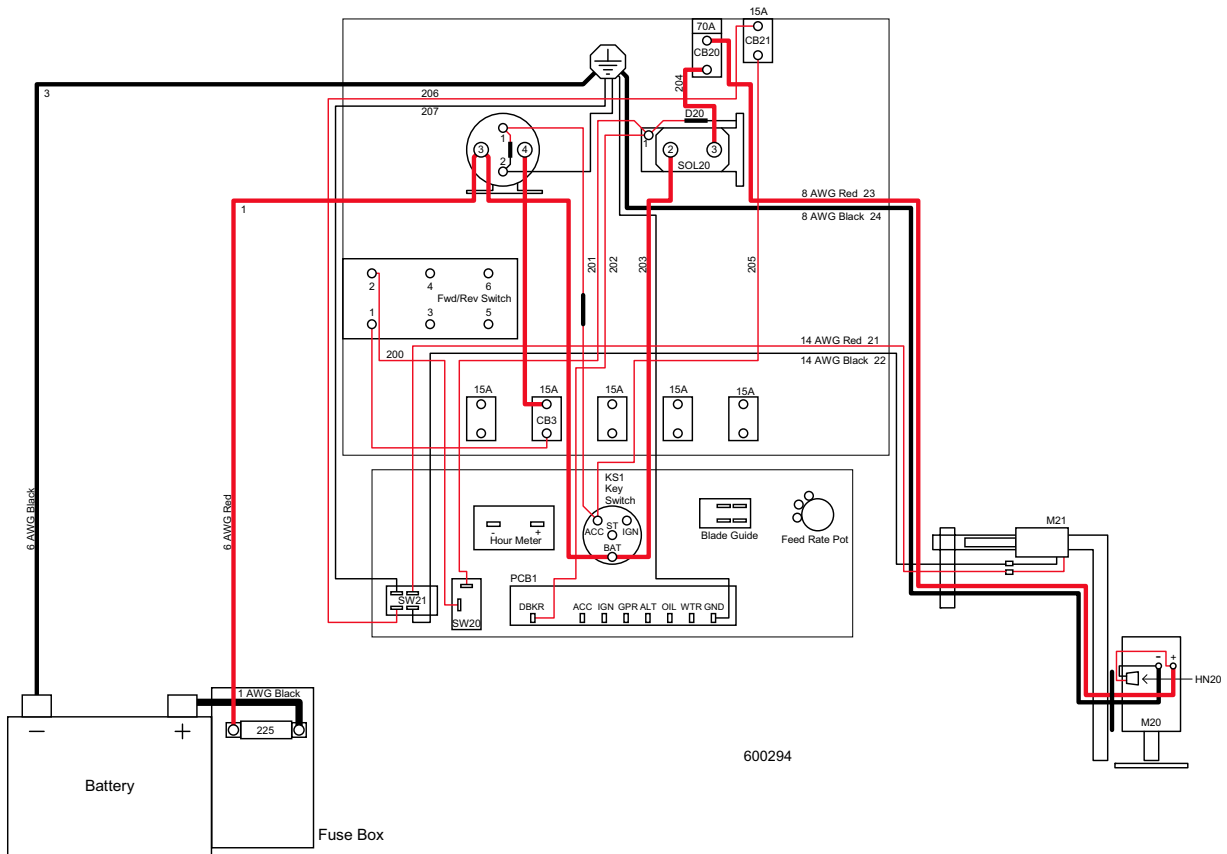

FIG. 5-3

# 5 Electrical Information

LT30 Super Rev. J3.00 - J3.08 LT40 Super Rev. J4.00 - J7.04 LT30HD/40HD Super Rev.

LT30 Super Rev. J3.00 - J3.08  
 LT40 Super Rev. J4.00 - J7.04  
 LT30HD/40HD Super Rev. J8.00 - K3.03  
 LT50HD Rev. A1.01 - A5.03

This diagram applies to non-Remote Super model sawmills built between 9/04 and 7/10 with softstart power feed system.

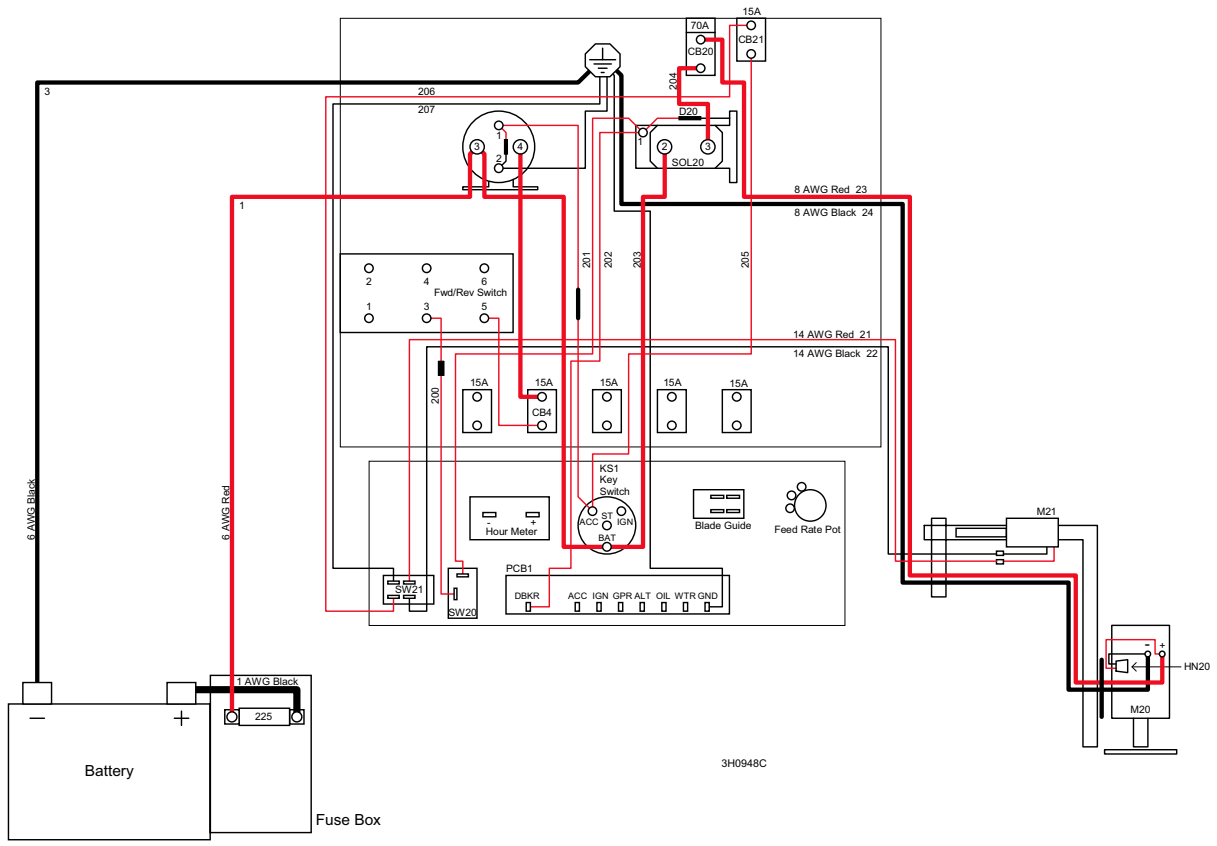

FIG. 5-4

LT30 Super Rev. F8.00 - J2.03  
LT40 Super Rev. F9.00 - J3.03  
LT30HD/40HD Super Rev. G1.00 - J7.03

This diagram applies to non-Remote Super model sawmills built before 9/04.

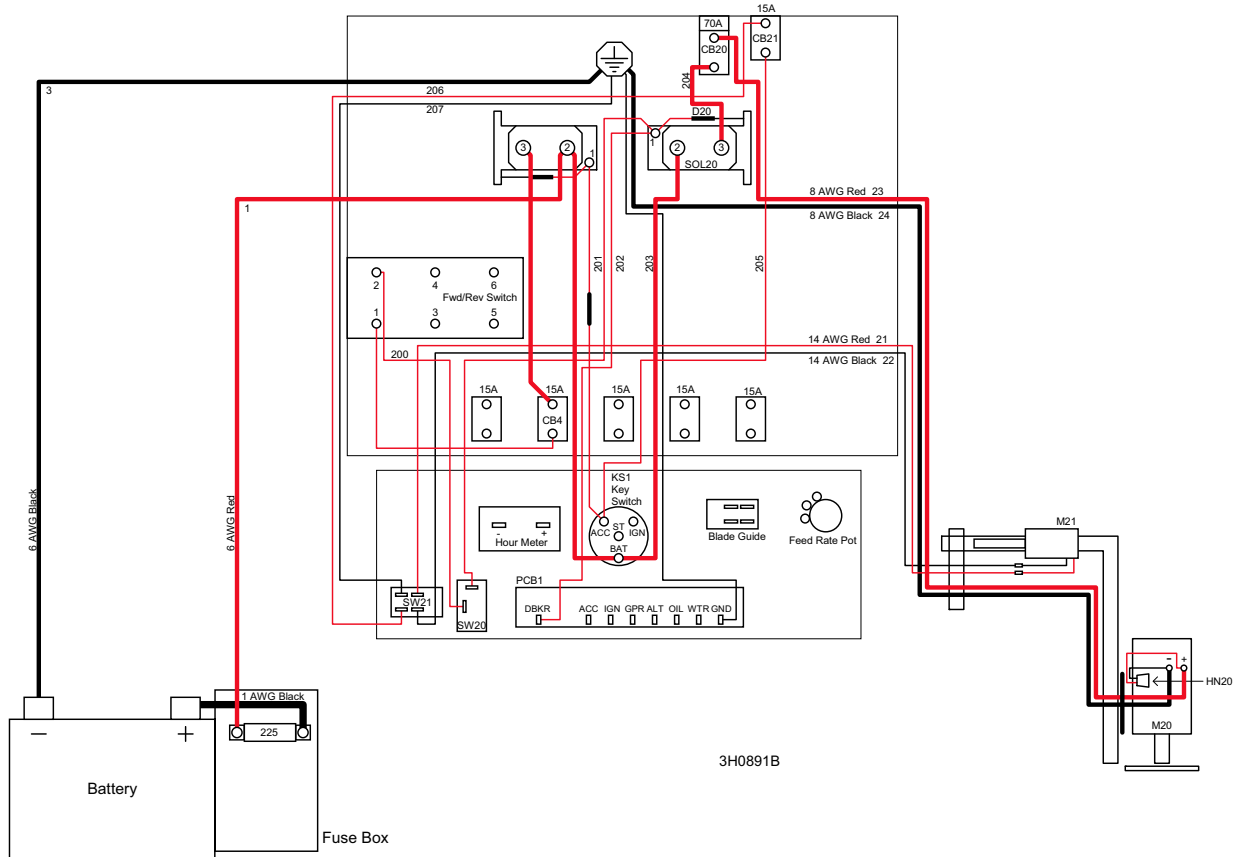

FIG. 5-5

# 5 Electrical Information

LT30/40 All Revs LT30HD/40HD All Revs

LT30/40  
LT30HD/40HD

All Revs  
All Revs

This diagram applies to all non-Remote Standard model sawmills.

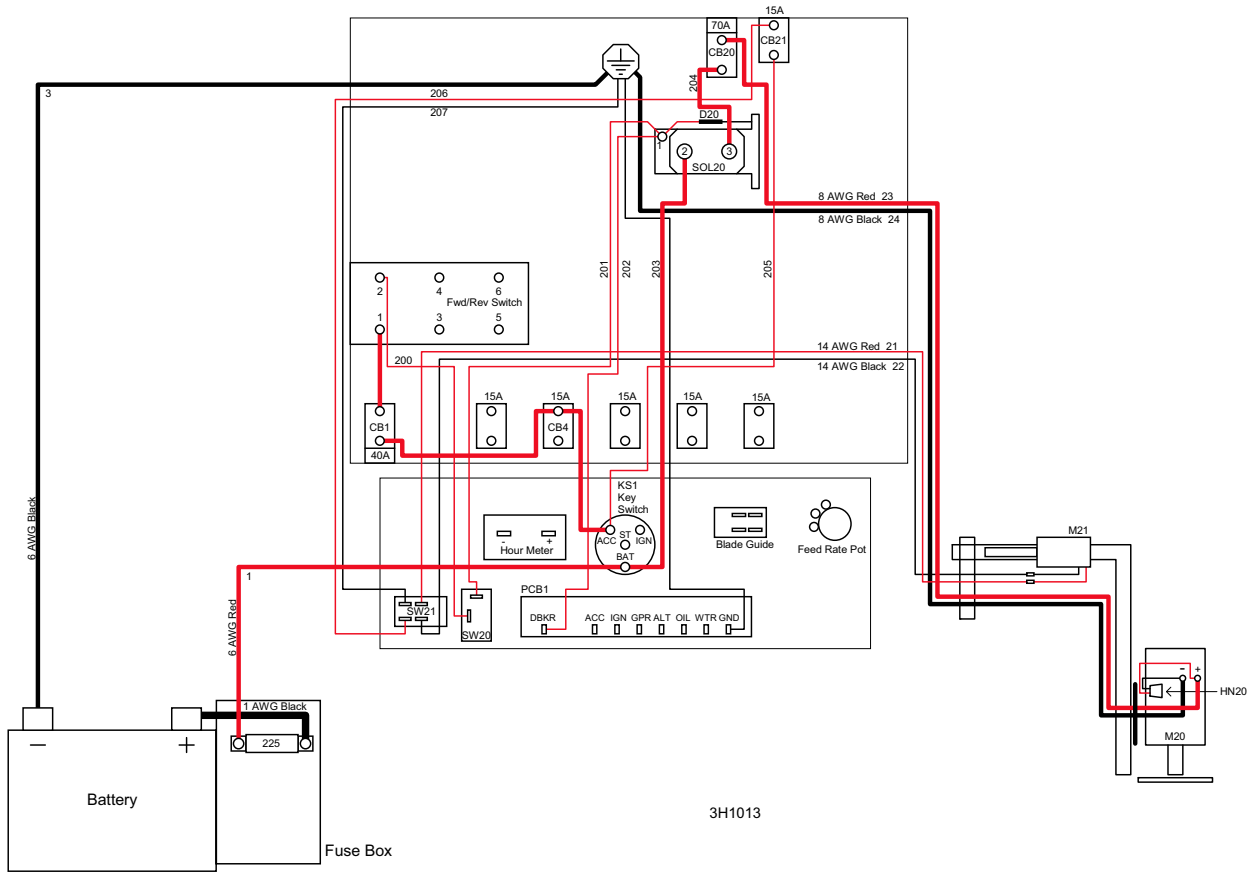
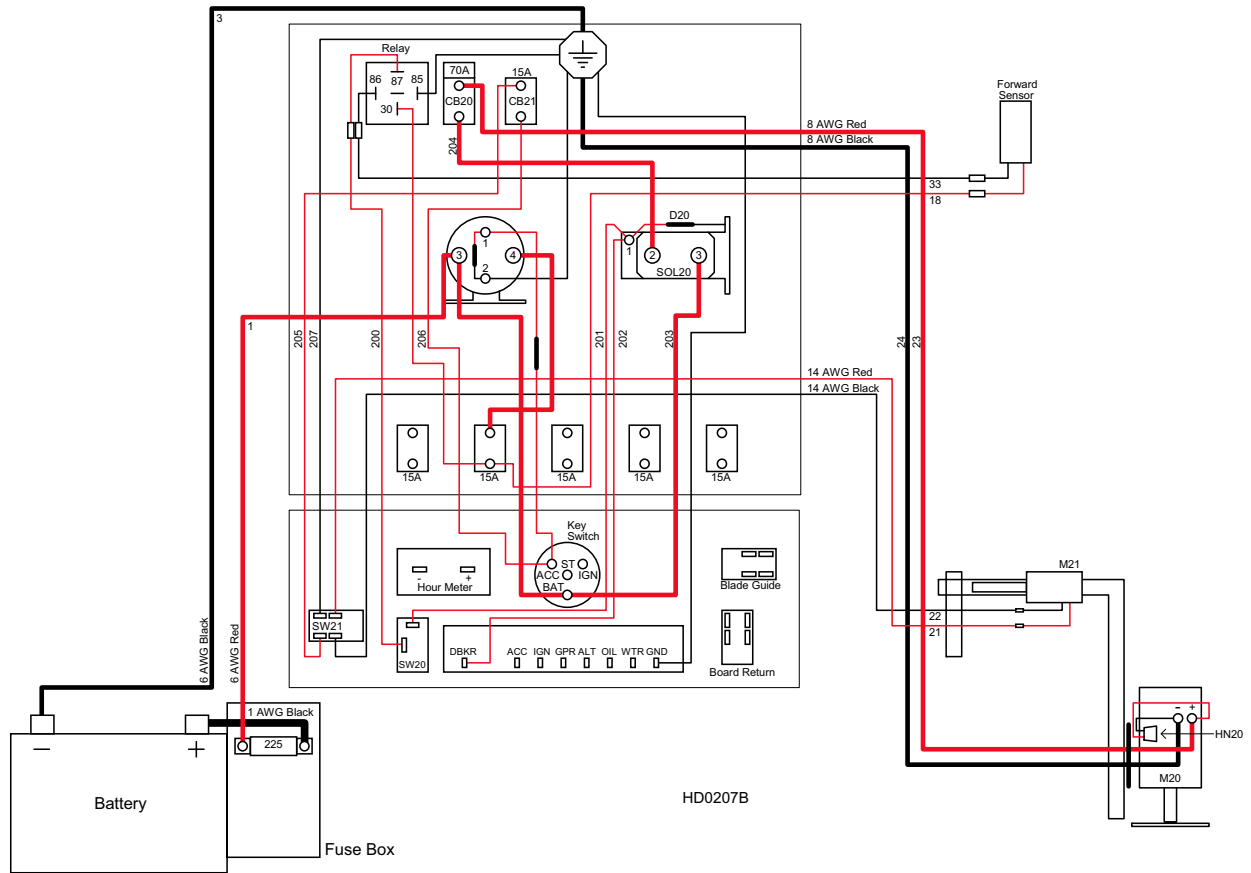

FIG. 5-6

**LT40HD-H Hydro Rev. J9.02+**

This diagram applies to LT40HD Hydro model sawmills.



**FIG. 5-7**

# 5 Electrical Information

## Electrical Wiring Diagram (Remote Sawmills)

### 5.5 Electrical Wiring Diagram (Remote Sawmills)

*LT40HD Super Remote*    *Rev. K3.00+*  
*LT50HD Remote*            *Rev. A5.00+*

This diagram applies to Super Remote model sawmills built after 1/09 with dual-axis Accuset 2 system.

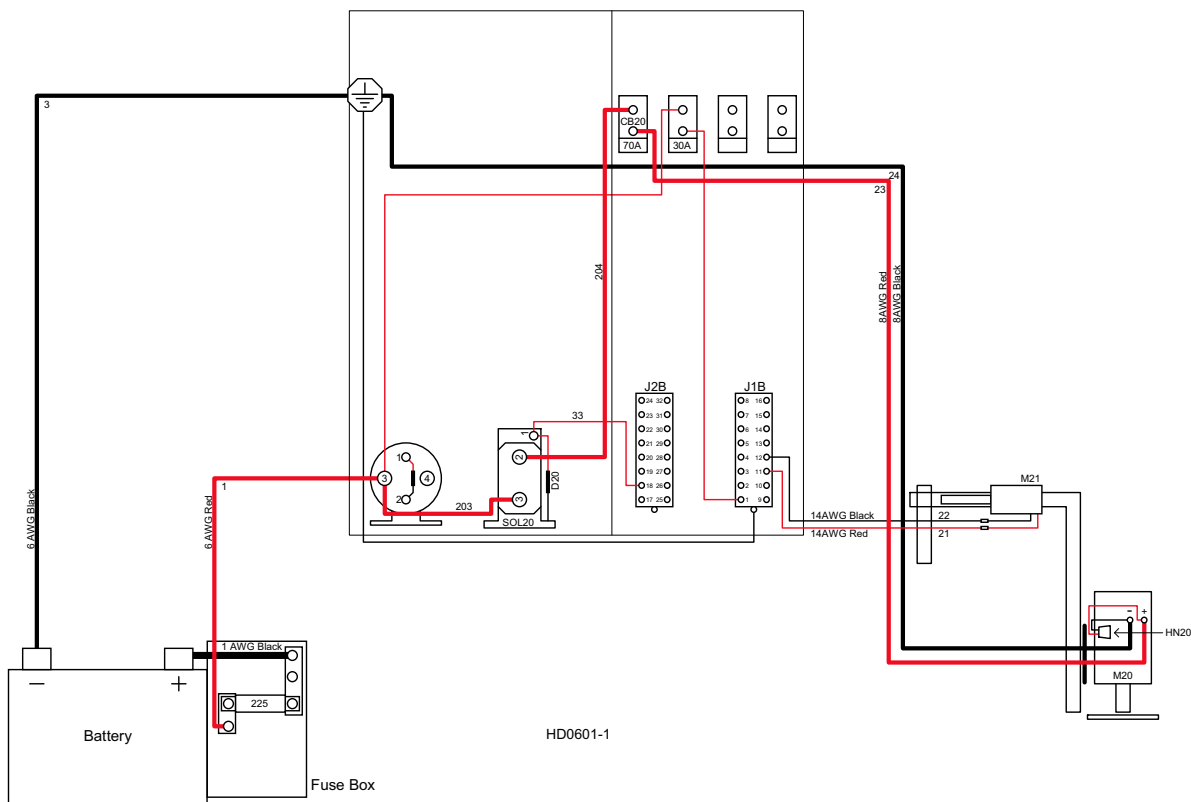

**FIG. 5-8 (PAGE 1 OF 2)**

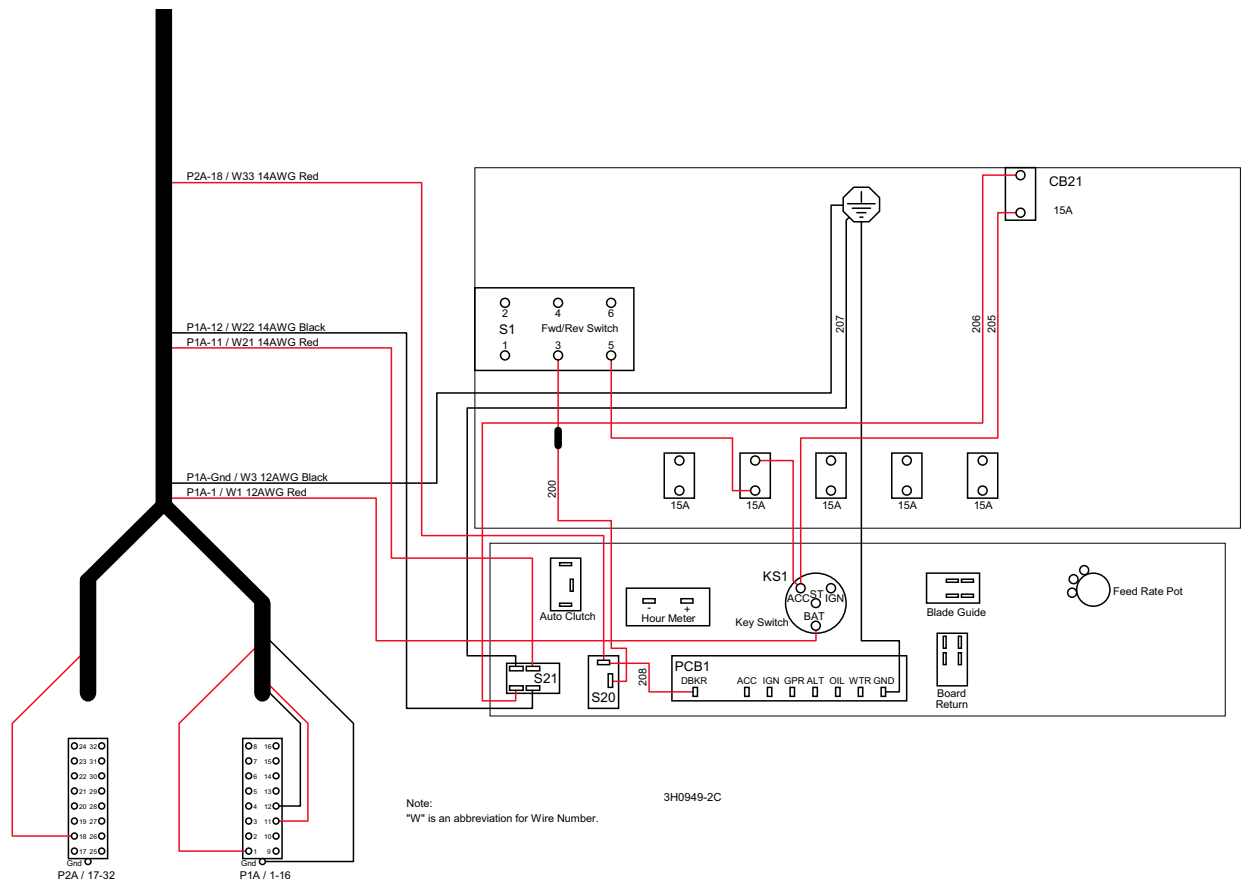

FIG. 5-9 (PAGE 2 OF 2)

# 5 Electrical Information

LT40HD Remote Rev. K5.00+

LT40HD Remote Rev. K5.00+

This diagram applies to Standard Remote model sawmills built after 1/09 with dual-axis Accuset 2 system.

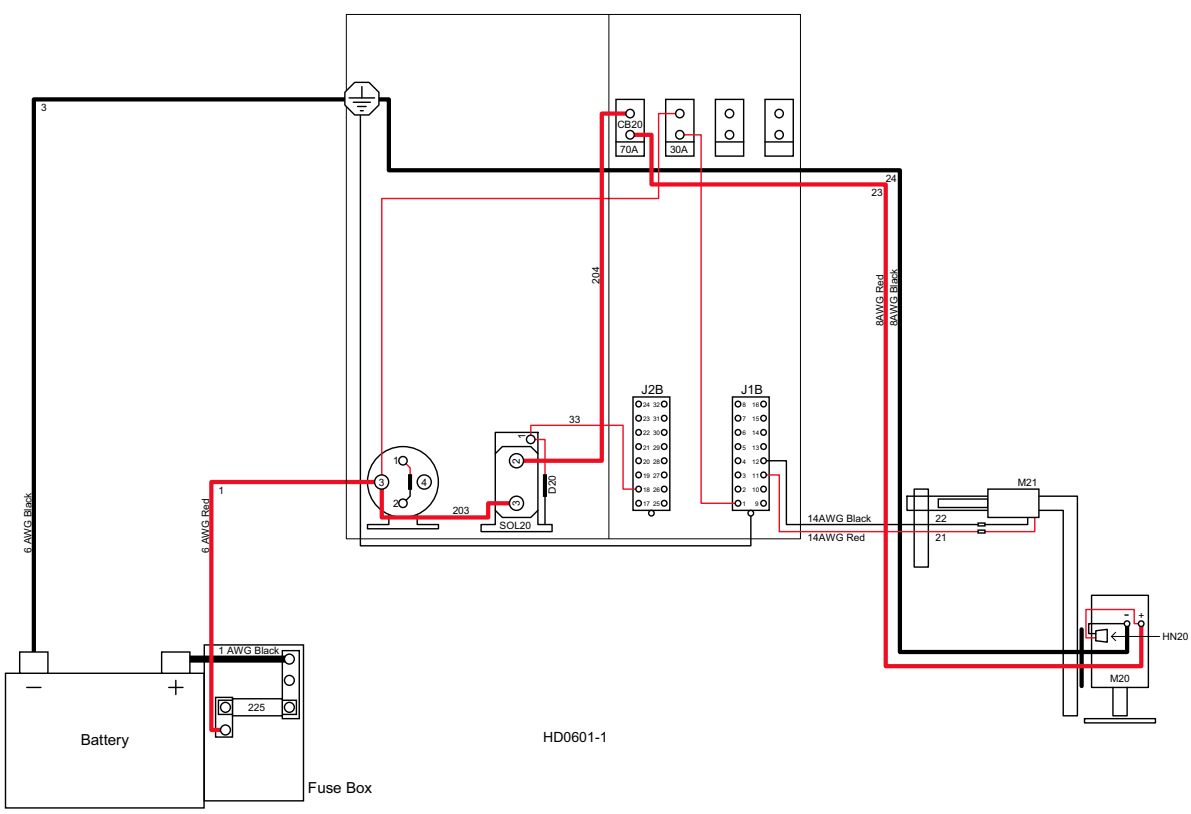

FIG. 5-10 (PAGE 1 OF 2)



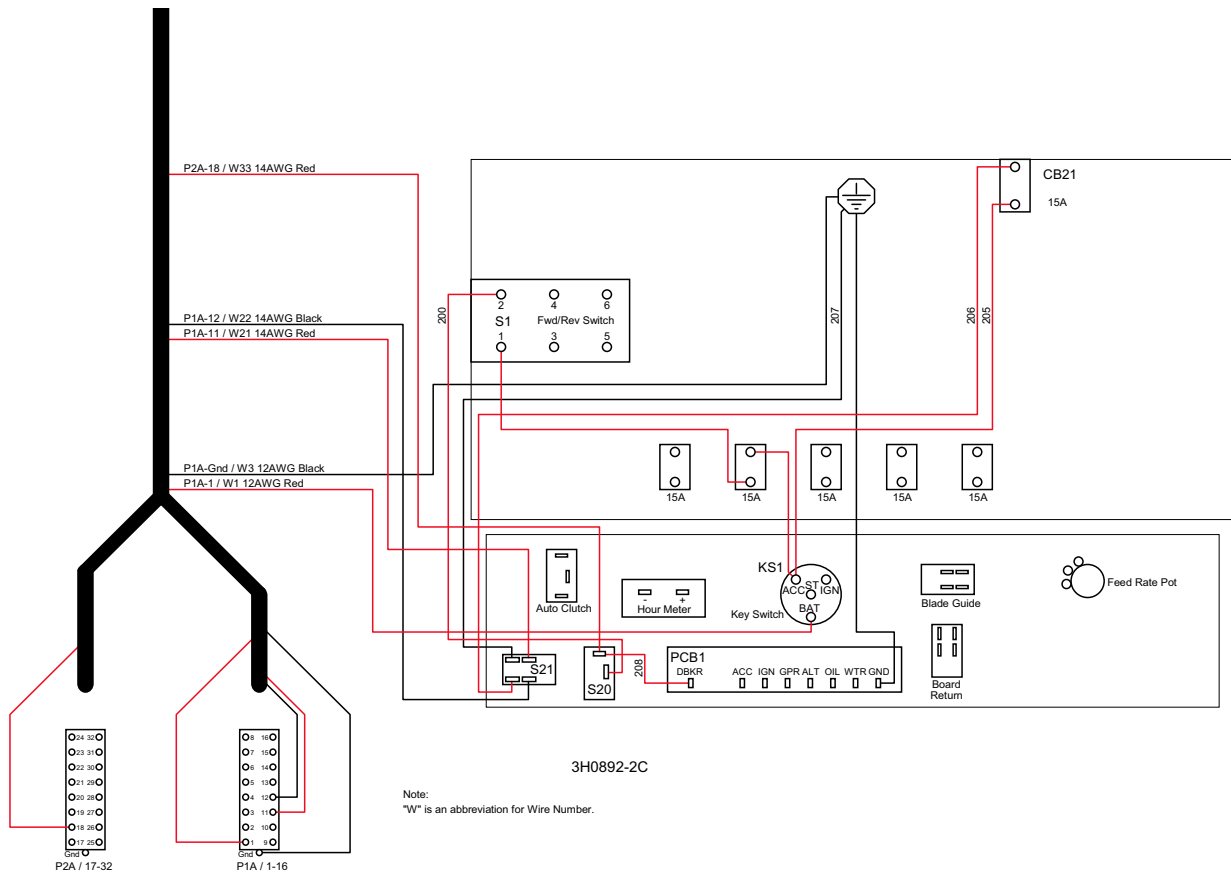

FIG. 5-11 (PAGE 2 OF 2)

# 5 Electrical Information

LT30HD Super Remote Rev. J8.00 - J8.09 LT40HD Super Remote Rev. J8.00 - K2.00

LT30HD Super Remote Rev. J8.00 - J8.09  
 LT40HD Super Remote Rev. J8.00 - K2.00  
 LT50HD Remote Rev. A1.01 - A4.00

This diagram applies to Super Remote model sawmills built between 9/04 and 12/08 with softstart power feed system.

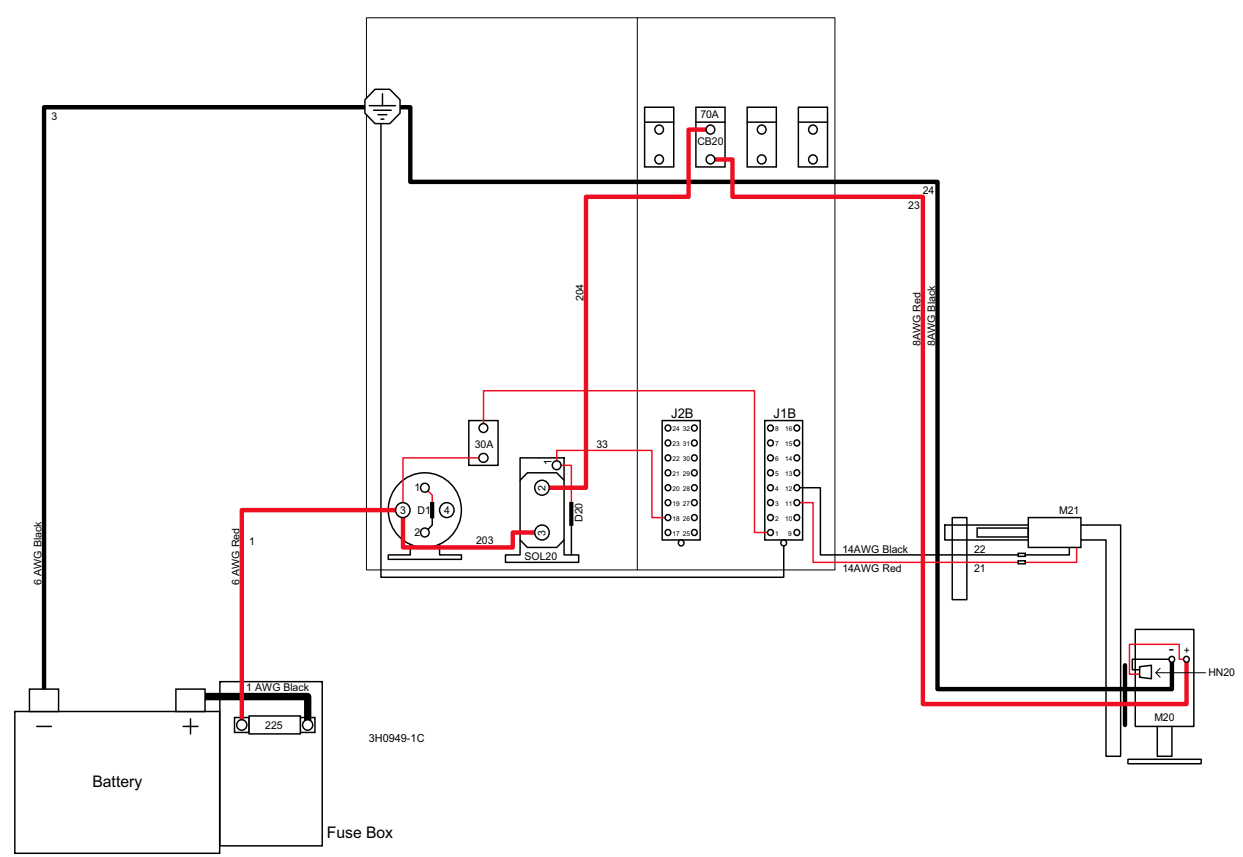

FIG. 5-12 (PAGE 1 OF 2)

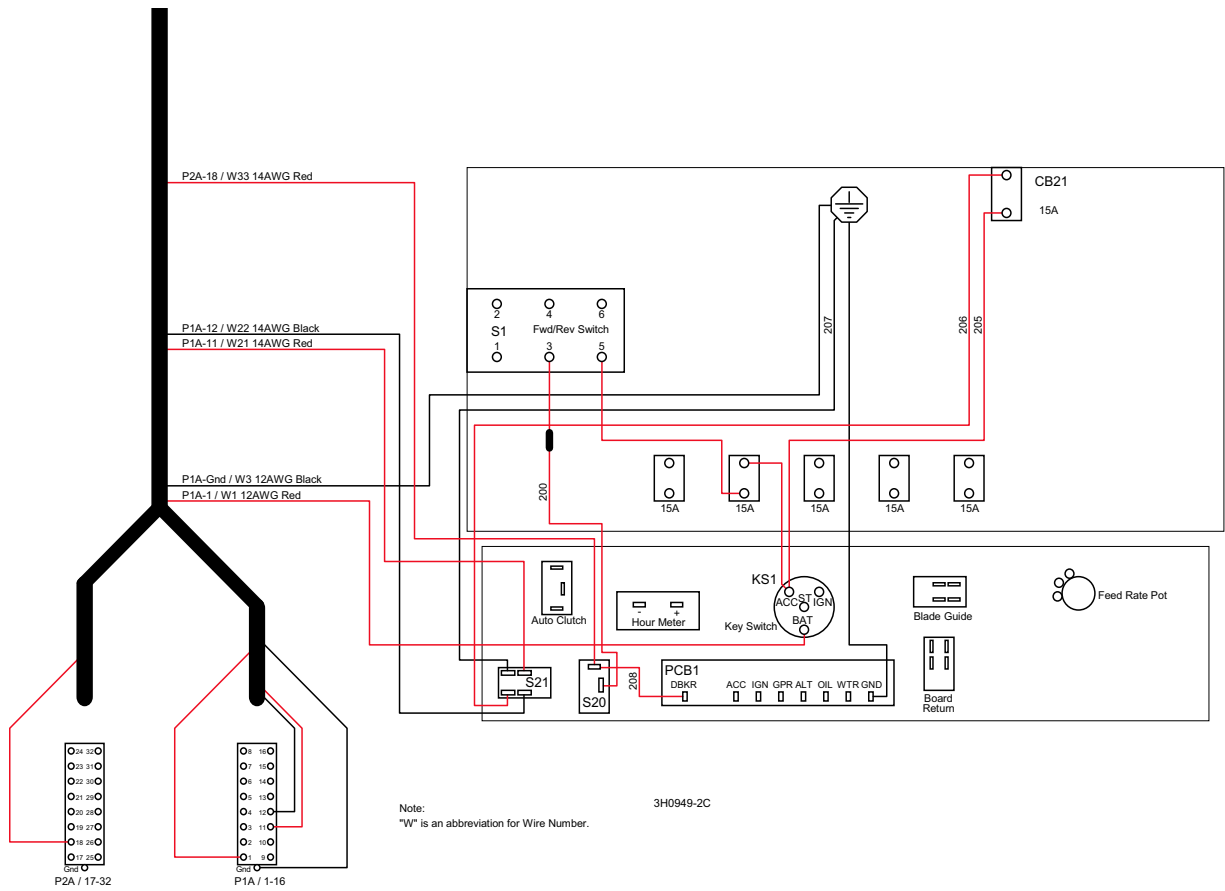

FIG. 5-13 (PAGE 2 OF 2)

# 5 Electrical Information

LT40HD Remote Rev. H4.00 - K4.01 LT30HD Super Remote Rev. G5.00 - J7.03 LT40HD

LT40HD Remote Rev. H4.00 - K4.01  
 LT30HD Super Remote Rev. G5.00 - J7.03  
 LT40HD Super Remote Rev. G5.00 - J7.03

This diagram applies to Standard Remote model sawmills built before 1/09 and Super Remote model sawmills built before 9/04.

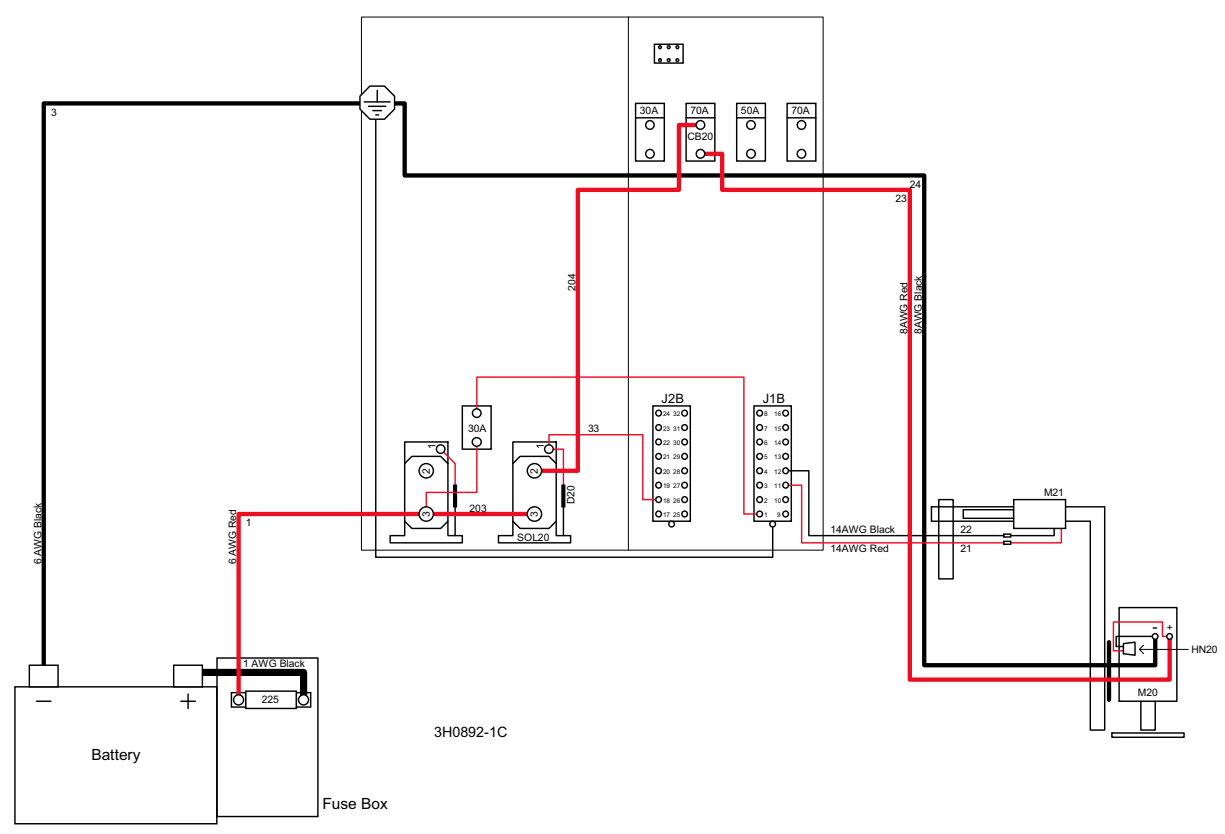

FIG. 5-14 (PAGE 1 OF 2)

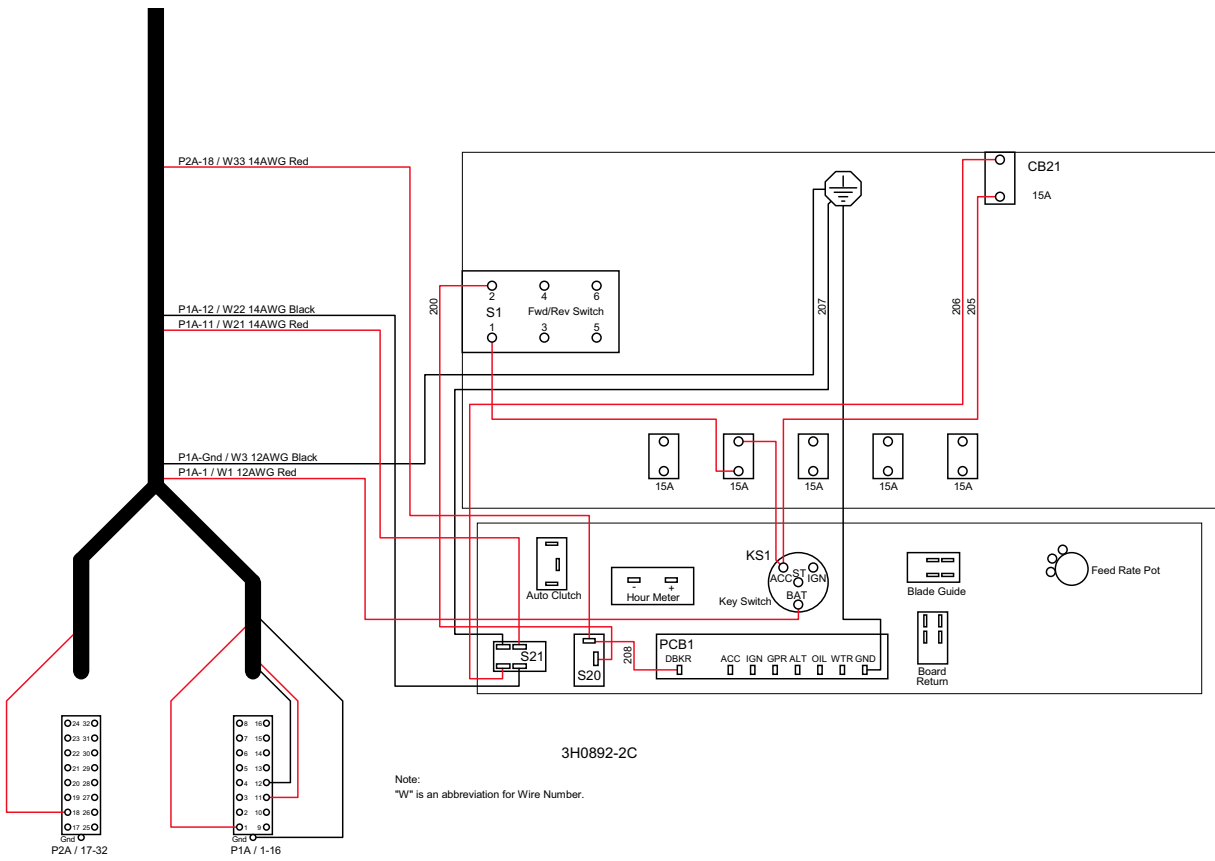

FIG. 5-15 (PAGE 2 OF 2)

# 5 Electrical Information

## Electrical Wiring Diagram (Wireless Sawmills)

### 5.6 Electrical Wiring Diagram (Wireless Sawmills)

LT40HD Wireless Rev. K1.01+  
 LT50HD Wireless Rev. A2.01+

This diagram applies to Wireless Super model sawmills.

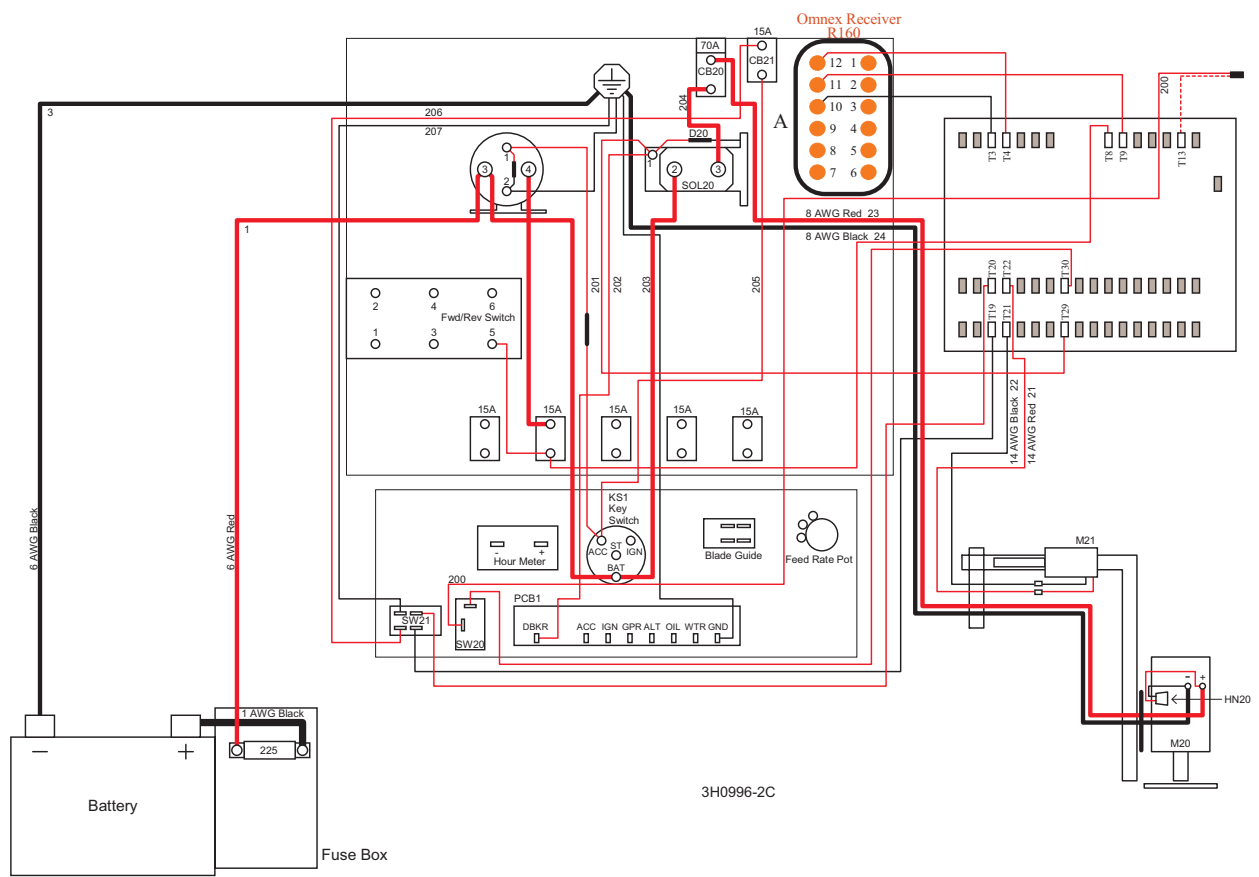
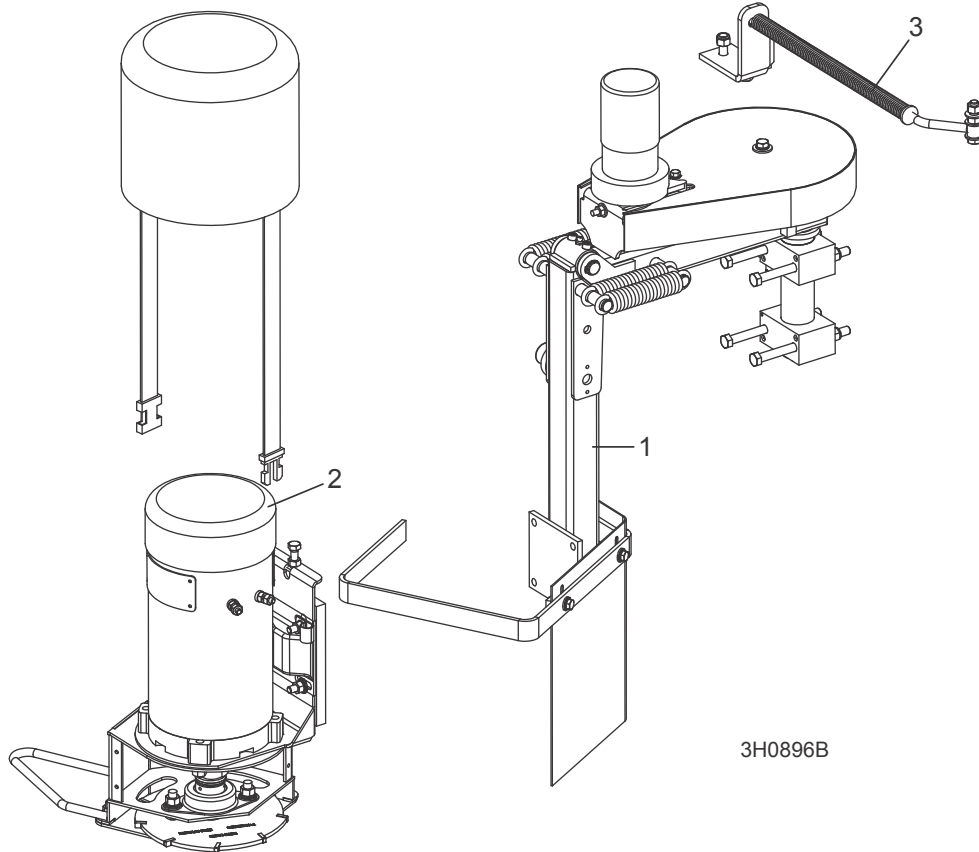

FIG. 5-16

## SECTION 6 DEBARKER PARTS

### 6.1 Mechanical Assembly



REF	DESCRIPTION (◆ Indicates Parts Available In Assemblies Only)	PART #	QTY.
For field installation of existing sawmills, order the mechanical assembly below plus the appropriate control kit ( <a href="#">See Section 6.10</a> ):			
	<b>MECHANICAL ASSEMBLY, MKII DEBARKER</b>	023617	1
1	Frame Parts ( <a href="#">See Section 6.2</a> )		
2	Cutter Head Parts ( <a href="#">See Section 6.5</a> )		
3	Spring Rod Parts ( <a href="#">See Section 6.9</a> )		

# 6 Debarker Parts

## Frame Assembly

### 6.2 Frame Assembly

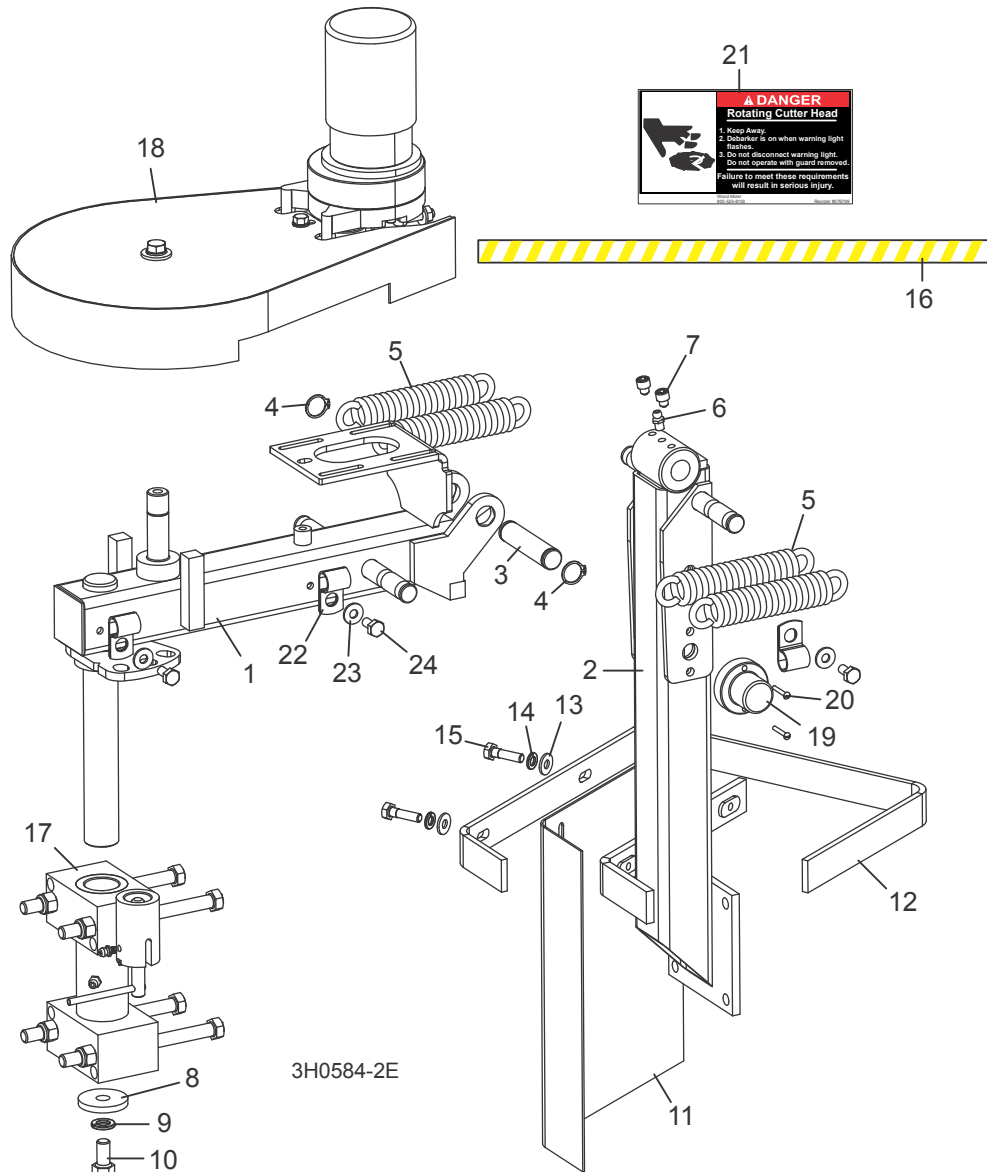

3H0584-2E

REF	DESCRIPTION (◆ Indicates Parts Available In Assemblies Only)	PART #	QTY.
	<b>FRAME ASSEMBLY, MKII DEBARKER</b>	023619	1
<b>1</b>	Arm Weldment, Debarker Upper	023641 <sup>1</sup>	1
<b>2</b>	Arm Weldment, Debarker Lower	023613	1
<b>3</b>	Pin, Debarker Frame Pivot	023646	1
<b>4</b>	Ring, 5/8" 5100-62 Outer Retaining	F04254-2	2
<b>5</b>	Spring, Debarker Arm	021185	4
<b>6</b>	Fitting, 1/4-28 Grease	P05060	1



7	Screw, 1/4-28 x 1/4" Socket Head	F05005-106	2	
8	Washer, .40 x 1.44 x .18	021276	1	
9	Washer, 3/8" Split Lock	F05011-4	1	
10	Bolt, 3/8-16 x 3/4" Hex Head Grade 2	F05007-27	1	
11	Guard, Debarker Flexible Debris	021232	1	
12	Guard, Debarker Wrap-Around	021231	1	
13	Washer, 1/4" SAE Flat	F05011-11	2	
14	Washer, 1/4" Split Lock	F05011-14	2	
15	Bolt, 1/4-20 x 1" Hex Head Grade 2	F05005-38	2	
16	Decal, Debarker Guard	015849	1	
17	Mount Parts ( <a href="#">See Section 6.3</a> )			
18	In/Out Motor Parts ( <a href="#">See Section 6.4</a> )			
19	Lamp Assembly, 180 Degree Amber Strobe	073555	1	
20	Bolt, 4-40x3/4 S	F05004-13	2	
21	Decal, Debarker Light Warning	076799	2	
22	<b>CLAMP, 1/2" EMT COATED</b>	P07584	3	
23	<b>WASHER, 1/4" SAE FLAT</b>	F05011-11	3	
24	<b>BOLT, 1/4-20 X 1/2" HEX HEAD</b>	F05005-15	3	

<sup>1</sup> Middle locking pin hole added to store Debarker in travel position if SLR or RS option mounted on sawmill bed (Rev. C.04).

# 6 Debarker Parts

## Mount/Lock Pin Assembly

### 6.3 Mount/Lock Pin Assembly

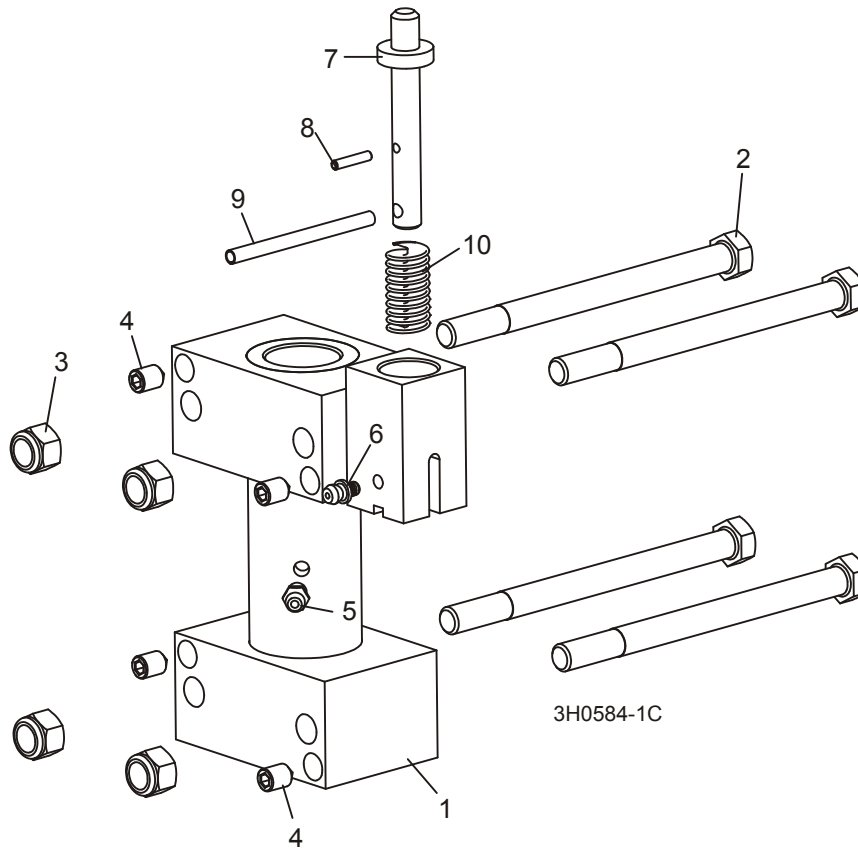

REF	DESCRIPTION (◆ Indicates Parts Available In Assemblies Only)	PART #	QTY.	
	<b>PIVOT KIT, DEBARKER MOUNT</b>	021284	1	
1	Mount Weldment, Debarker Frame Pivot	021282	1	◆
2	Bolt, 3/8-16 x 5" Hex Head	F05007-5	4	
3	Nut, 3/8-16 Hex Nylon Lock	F05010-10	4	
4	Screw, 5/16-24 x 1/2" Cone Point Socket Set	F05006-96	4	
5	Fitting, 1/4-28 Grease	P05060	1	
6	Fitting, 3/16" x 3/16" Straight Grease	P04107 <sup>1</sup>	1	
7	<b>PIN, DEBARKER LOCK</b>	023650	1	
8	<b>PIN, 1/8" X 1" ROLL</b>	F05012-34 <sup>2</sup>	1	
9	<b>PIN, 3/16" X 2 1/2" ROLL</b>	F05012-27	1	
10	<b>SPRING, .58" OD X 1 1/8" LONG COMPRESSION</b>	021243	1	

<sup>1</sup> Grease fitting added to travel pin block 11/07.

<sup>2</sup> 1" Roll Pin F05012-34 replaces 5/8" Roll Pin F05012-14 for easier assembly (4/08).

## 6.4 In/Out Motor Drive Assembly

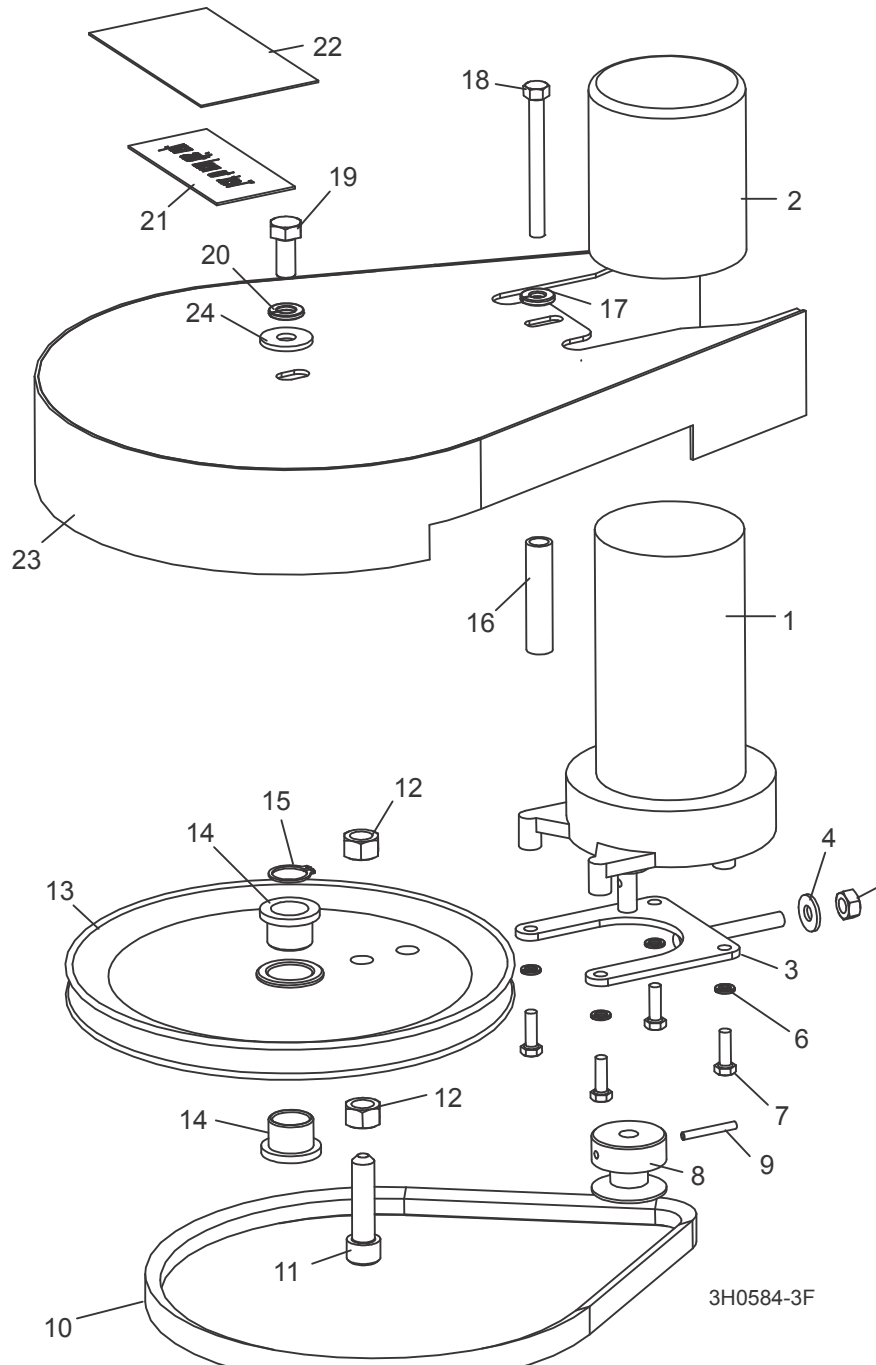

REF	DESCRIPTION (◆ Indicates Parts Available In Assemblies Only)	PART #	QTY.
1	<b>MOTOR, CURRENT APPLICATIONS 1/30HP 12VDC GEAR</b>	079214 <sup>1</sup>	1
	Gear Kit, Gear Motor Replacement	061232	1

## 6

**Debarker Parts***In/Out Motor Drive Assembly*

	Brush Kit, Gear Motor Replacement	061234	1	
	Shaft Kit, Gear Motor Replacement	061233	1	
2	<b>BOOT, GEAR MOTOR WEATHER</b>	023720	1	
3	<b>TENSIONER WELDMENT, GEAR MOTOR</b>	023637	1	
4	<b>WASHER, 1/4" SAE FLAT</b>	F05011-11	1	
5	<b>NUT, 1/4-20 HEX LOCK</b>	F05010-21	1	
6	<b>WASHER, #10 SPLIT LOCK</b>	F05011-20	4	
7	<b>BOLT, #10-32 X 5/8" HEX HEAD</b>	F05004-152	4	
8	<b>PULLEY, DEBARKER IN/OUT MOTOR</b>	016181 <sup>2</sup>	1	
9	<b>PIN, 1/8" X 1" ROLL</b>	F05012-34 <sup>2</sup>	1	
10	<b>BELT, 4L280</b>	P04031	1	
11	<b>BOLT, 3/8-16 X 1 1/2" SOCKET HEAD</b>	F05007-36	1	
12	<b>NUT, 3/8-16 HEX LOCK</b>	F05010-25	2	
13	<b>PULLEY, DEBARKER IN/OUT DRIVE</b>	023634	1	
14	<b>BUSHING, FLANGED BRONZE</b>	021203	2	
15	<b>RING, 5/8" 5100-62 OUTSIDE RETAINING</b>	F04254-2	1	
16	<b>SPACER, 5/16" ID X 7/16" OD X 1 15/16" LONG</b>	014424	1	
17	<b>WASHER, 1/4" SPLIT LOCK</b>	F05011-14	1	
18	<b>BOLT, 1/4-20 X 2 1/2" HEX HEAD</b>	F05005-7	1	
19	<b>BOLT, 5/16-18 X 3/4" HEX HEAD GRADE 2</b>	F05006-5	1	
20	<b>WASHER, 5/16" SPLIT LOCK</b>	F05011-13	1	
21	<b>DECAL, DEBARKER REVISION</b>	016187	1	
22	<b>OVERLAY, REVISION DECAL</b>	016200	1	
23	<b>GUARD WELDMENT, DEBARKER PULLEY</b>	023649	1	
24	<b>WASHER, 5/16" STANDARD FLAT</b>	F05011-16 <sup>3</sup>	1	

<sup>1</sup> Replaced P09698-1 1/30 HP 62RPM 12VDC 53:1 Gear Motor with P12756 End Housing, P12569 Gear Kit, P12800 Brush Kit and 009695 Shaft Kit (Rev. C.06).

<sup>2</sup> Gear Motor Pulley 016181 and Roll Pin F05012-34 replace Gear Motor Pulley 021190 with 1/4-20 x 3/8" Cup Point Set Screw F05005-47 originally supplied prior to Rev. C.01. Roll pin required to install new pulley to older revision Debarkers.

<sup>3</sup> Added 2/10 to cover slot to prevent moisture entering guard.

## 6.5 Blade Motor Assembly

Rev. C.05+

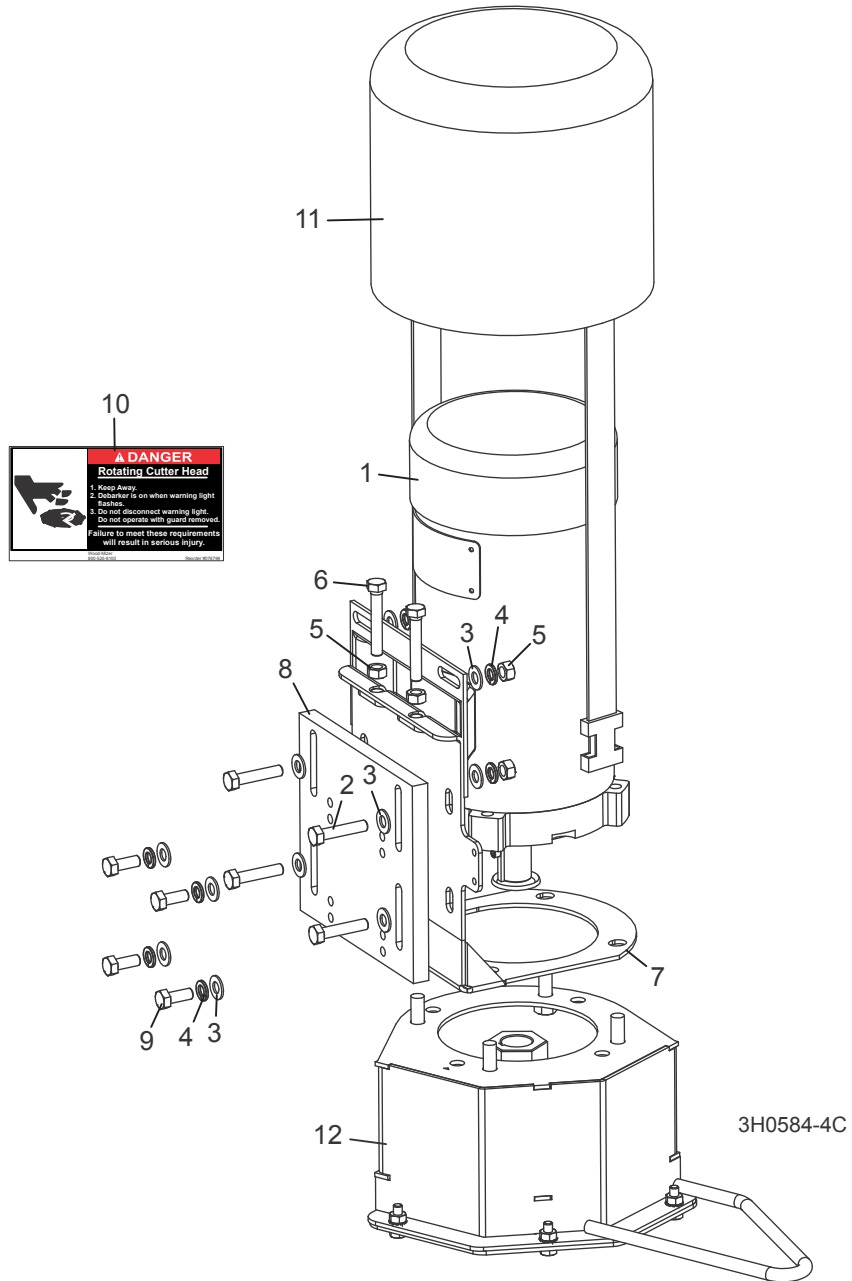

REF	DESCRIPTION (◆ Indicates Parts Available In Assemblies Only)	PART #	QTY.
	<b>HEAD ASSEMBLY, MKII DEBARKER CUTTING</b>	023618	1
1	Motor, 3/4HP 12VDC TEFC Electric (7/8" Dia. Shaft)	023688 <sup>1</sup>	1
	Motor, 3/4HP 12VDC TEFC Electric (5/8" Dia. Shaft)	015174 <sup>1</sup>	1
	Brush Kit, Leeson 3/4HP Motor (Includes 2 Brushes and 2 Springs)	024167	1
	Fan, 3/4 HP Leeson Motor Replacement	016087	1

**6****Debarker Parts**  
*Blade Motor Assembly*

	Guard, Motor Fan	047998	1	
	Key, 3/16" Square x 1 3/8" Long	016108	1	
<b>2</b>	Bolt, 5/16-18 x 1 1/2" Hex Head Full Thread	F05006-2	4	
<b>3</b>	Washer, 5/16" SAE Flat	F05011-17	8	
<b>4</b>	Washer, 5/16" Split Lock	F05011-13	8	
<b>5</b>	Nut, 5/16-18 Hex	F05010-17	6	
<b>6</b>	Bolt, 5/16-18 x 2" Hex Head Full Thread	F05006-13	2	
<b>7</b>	Bracket Weldment, Debarker Blade Motor Adjustable	023622	1	
<b>8</b>	Plate, Debarker Blade Motor Mount	023620	1	
<b>9</b>	Bolt, 5/16-18 x 3/4" Hex Head Grade 2	F05006-5	4	
<b>10</b>	Decal, Debarker Light Warning	076799	1	
<b>11</b>	Cover, 3/4HP Leeson Motor	015761	1	
<b>12</b>	Blade/Mandrel Parts ( <a href="#">See Section 6.7</a> )			

<sup>1</sup> 023688 Motor with 7/8" shaft replaces 015174 Motor with 5/8" dia. shaft (Rev. B.00). To upgrade Rev. A.00 Debarker with new motor requires new mandrel ([See Section 6.7](#)).

## 6.6 Blade Motor Assembly

Rev. A.00 - C.04

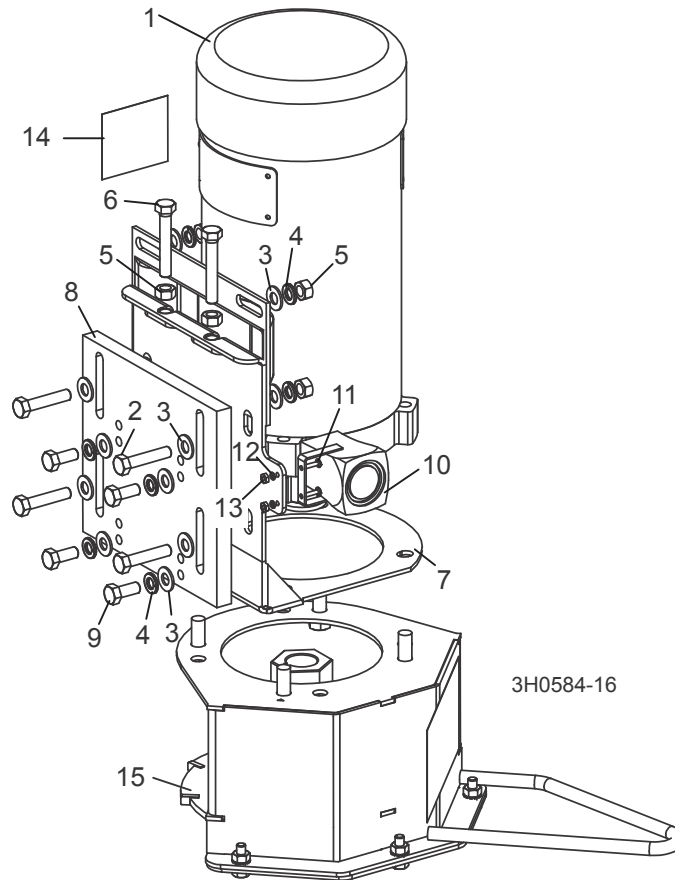

REF	DESCRIPTION (◆ Indicates Parts Available In Assemblies Only)	PART #	QTY.
	<b>HEAD ASSEMBLY, MKII DEBARKER CUTTING</b>	023618	1
1	Motor, 3/4HP 12VDC TEFC Electric (7/8" Dia. Shaft)	023688 <sup>1</sup>	1
	Motor, 3/4HP 12VDC TEFC Electric (5/8" Dia. Shaft)	015174 <sup>1</sup>	1
	Brush Kit, Leeson 3/4HP Motor (Includes 2 Brushes and 2 Springs)	024167	1
	Fan, 3/4 HP Leeson Motor Replacement	016087	1
	Guard, Motor Fan	047998	1
	Key, 3/16" Square x 1 3/8" Long	016108	1
2	Bolt, 5/16-18 x 1 1/2" Hex Head Full Thread	F05006-2	4
3	Washer, 5/16" SAE Flat	F05011-17	8
4	Washer, 5/16" Split Lock	F05011-13	8
5	Nut, 5/16-18 Hex	F05010-17	6
6	Bolt, 5/16-18 x 2" Hex Head Full Thread	F05006-13	2
7	Bracket Weldment, Debarker Blade Motor Adjustable	023622	1
8	Plate, Debarker Blade Motor Mount	023620	1
9	Bolt, 5/16-18 x 3/4" Hex Head Grade 2	F05006-5	4
10	Horn, 12V DC	021137	1

**6****Debarker Parts***Blade Motor Assembly*

---

<b>11</b>	Screw, 4-40x1/2 SI Rnd Head Machine	F05004-14	2	
<b>12</b>	Washer, #4 Split Lock	F05011-21	2	
<b>13</b>	Nut, #4-40 Hex	F05010-43	2	
<b>14</b>	Decal, Disconnect Motor Leads Warning	024431	1	
<b>15</b>	Blade/Mandrel Parts ( <a href="#">See Section 6.7</a> )			

<sup>1</sup> 023688 Motor with 7/8" shaft replaces 015174 Motor with 5/8" dia. shaft (Rev. B.00). To upgrade Rev. A.00 Debarker with new motor requires new mandrel ([See Section 6.7](#)).



## 6.7 Blade Housing Assembly

Rev. C.00+

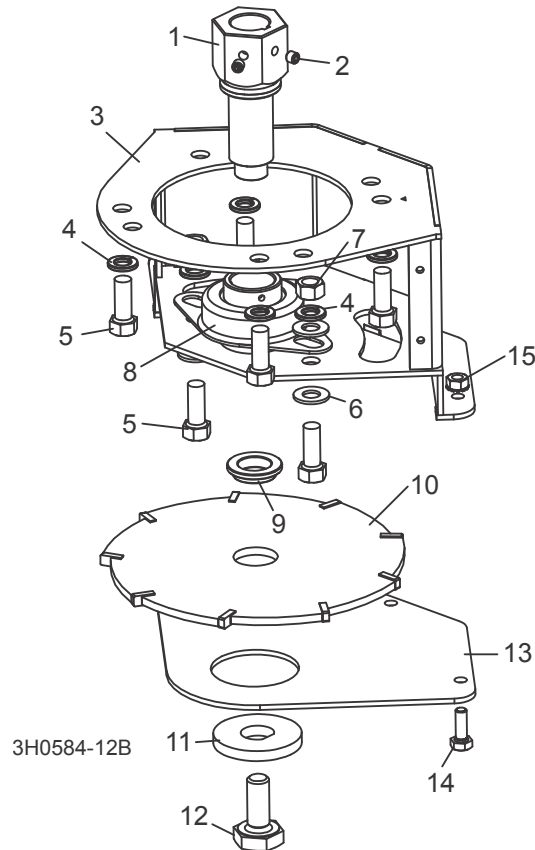

REF	DESCRIPTION (◆ Indicates Parts Available In Assemblies Only)	PART #	QTY.	
1	MANDREL, DEBARKER BLADE (7/8" DIA.)	016122 <sup>1</sup>	1	
2	SCREW, 1/4-28 X 1/4" CUP POINT SOCKET SET	F05005-105	2	
3	HOUSING WELDMENT, DEBARKER BLADE	023628 <sup>2</sup>	1	
4	WASHER, 3/8" SPLIT LOCK	F05011-4	6	
5	BOLT, 3/8-16 X 1" HEX HEAD	F05007-7	6	
6	WASHER, 3/8" SAE FLAT	F05011-3	4	
7	NUT, 3/8-16 HEX	F05010-1	2	
8	BEARING, 1" FLANGED MOUNT	023541	1	
9	BUSHING, DEBARKER BLADE SPACER	023632	1	
10	BLADE, DEBARKER 7" DIA.	021236	1	
	BLADE, DEBARKER 7" DIA. W/1/2" INSERTS (OPTIONAL - PURCHASED SEPARATELY)	065852	1	
11	WASHER, DEBARKER BLADE LOCK	023737 <sup>1</sup>	1	
12	BOLT, 1/2-20 X 1 1/4" HEX HEAD SPECIAL	023547 <sup>3</sup>	1	

**6****Debarker Parts***Blade Housing Assembly*

---

<b>13</b>	<b>PLATE, DEBARKER BLADE HOUSING BOTTOM</b>	023629	1	
<b>14</b>	<b>BOLT, 1/4-20 X 3/4" HEX HEAD FULL THREAD</b>	F05005-1	3	
<b>15</b>	<b>NUT, 1/4-20 SELF-LOCKING HEX</b>	F05010-9	3	

<sup>1</sup> Mandrel and washer with "D"-shaped hole used to prevent slippage (Rev. C.00).

<sup>2</sup> Housing weldment modified to accept CE guards required in Europe (Rev. C.00).

<sup>3</sup> Radius added to blade bolt 023547 to prevent damage caused by over-torquing of the bolt (Rev. C.00).

## 6.8 Blade Housing Assembly

Rev. A.00 - B.00

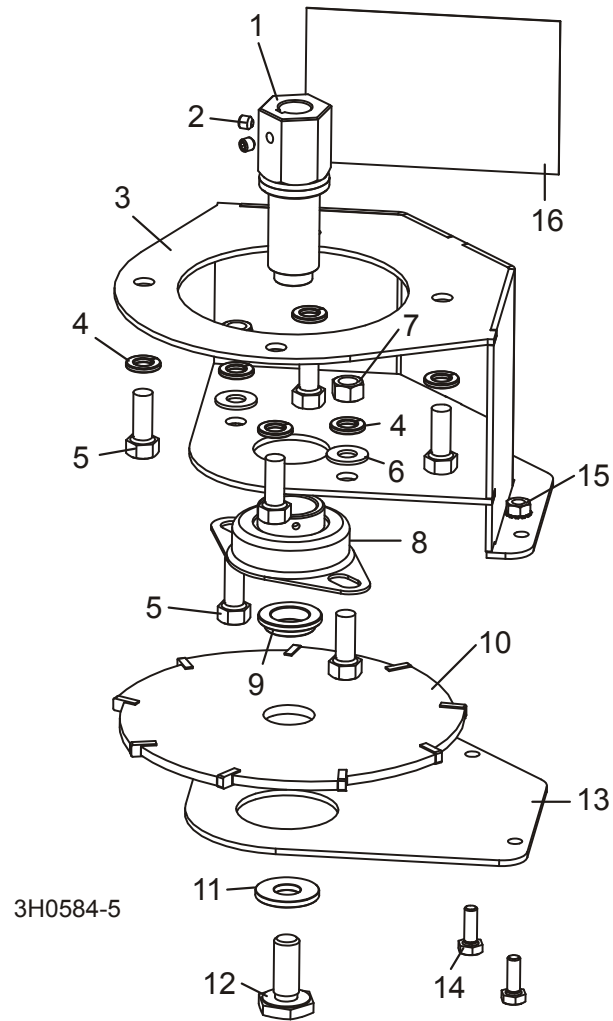

REF	DESCRIPTION (◆ Indicates Parts Available In Assemblies Only)	PART #	QTY.	
1	MANDREL, DEBARKER BLADE (7/8" DIA.)	023689 <sup>1</sup>	1	◆
	MANDREL, DEBARKER BLADE (5/8" DIA.)	021385 <sup>1</sup>	1	
2	SCREW, 1/4-28 X 1/4" CUP POINT SOCKET SET	F05005-105	2	
3	HOUSING WELDMENT, DEBARKER BLADE	023628	1	
4	WASHER, 3/8" SPLIT LOCK	F05011-4	6	
5	BOLT, 3/8-16 X 1" HEX HEAD	F05007-7	6	
6	WASHER, 3/8" SAE FLAT	F05011-3	2	
7	NUT, 3/8-16 HEX	F05010-1	2	
8	BEARING, 1" FLANGED MOUNT	023541	1	
9	BUSHING, DEBARKER BLADE SPACER	023632	1	

## 6

**Debarker Parts***Blade Housing Assembly*

10	BLADE, DEBARKER 7" DIA.	021236	1	
	BLADE, DEBARKER 7" DIA. W/1/2" INSERTS (OPTIONAL - PURCHASED SEPARATELY)	065852	1	
11	WASHER, DEBARKER BLADE RETAINING	023633	1	
12	BOLT, 1/2-20 X 1 1/4" HEX HEAD SPECIAL	023547	1	
13	PLATE, DEBARKER BLADE HOUSING BOTTOM	023629	1	
14	BOLT, 1/4-20 X 3/4" HEX HEAD FULL THREAD	F05005-1	3	
15	NUT, 1/4-20 SELF-LOCKING HEX	F05010-9	3	
16	DECAL, DEBARKER HORN DANGER	021172	1	

<sup>1</sup> 023689 7/8" Mandrel obsolete. Replace all 7/8" mandrels with 016122 mandrel and 023737 washer with "D"-shaped hole to prevent slippage ([See Section 6.7](#)). Use 021385 5/8" Mandrel with 015174 motor supplied with Rev. A.00 Debarkers.

## 6.9 Spring Rod Assembly

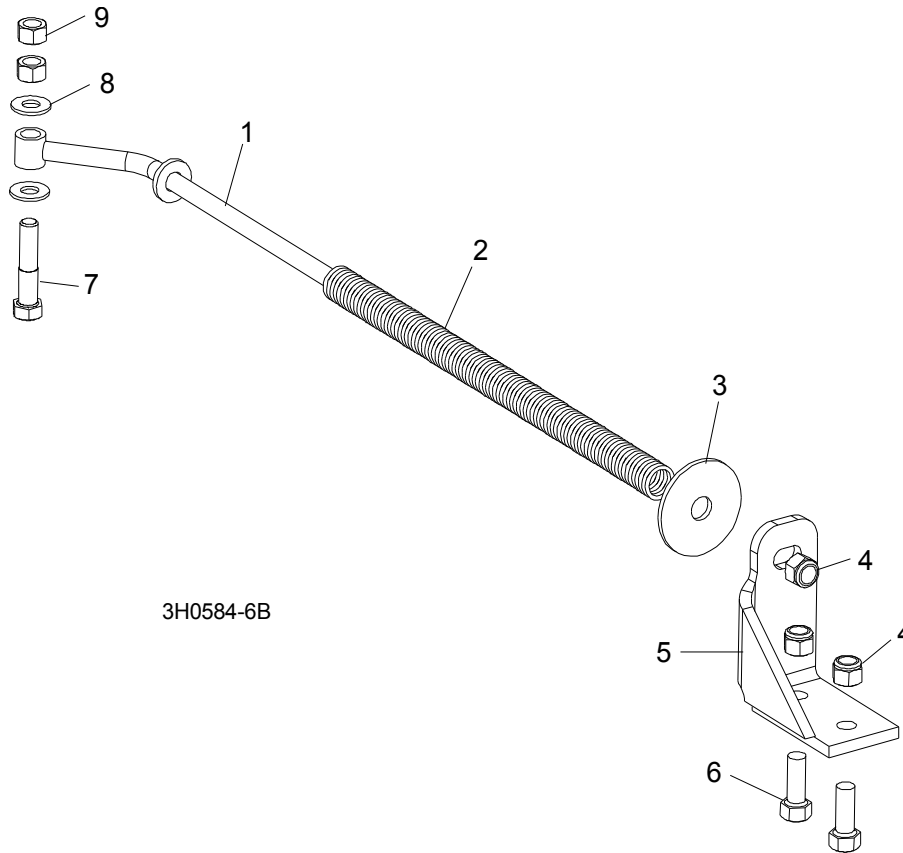

REF	DESCRIPTION (◆ Indicates Parts Available In Assemblies Only)	PART #	QTY.
<b>1</b>	<b>ROD ASSEMBLY, DEBARKER SPRING</b>	016182 <sup>1</sup>	1
1	Rod Weldment, Debarker Spring	021179	1
2	Spring, Debarker Compression	023631	1
3	Washer, 1/2" ID x 2" OD Fender	F05011-38	1
4	Nut, 3/8-16 Nylon Lock	F05010-10	3
5	Bracket, Spring Rod Mount	021180	1
6	Bolt, 3/8-16 x 1" Hex Head	F05007-7	2
7	Bolt, 3/8-16 x 1 3/4" Hex Head Grade 2	F05007-119	1
8	Washer, 3/8" SAE Flat	F05011-3	2
9	Nut, 3/8-16 Hex Lock	F05010-25	2

<sup>1</sup> New subassembly created with Rev. C.01 (10/98).

## 6.10 Debarker Control Assembly

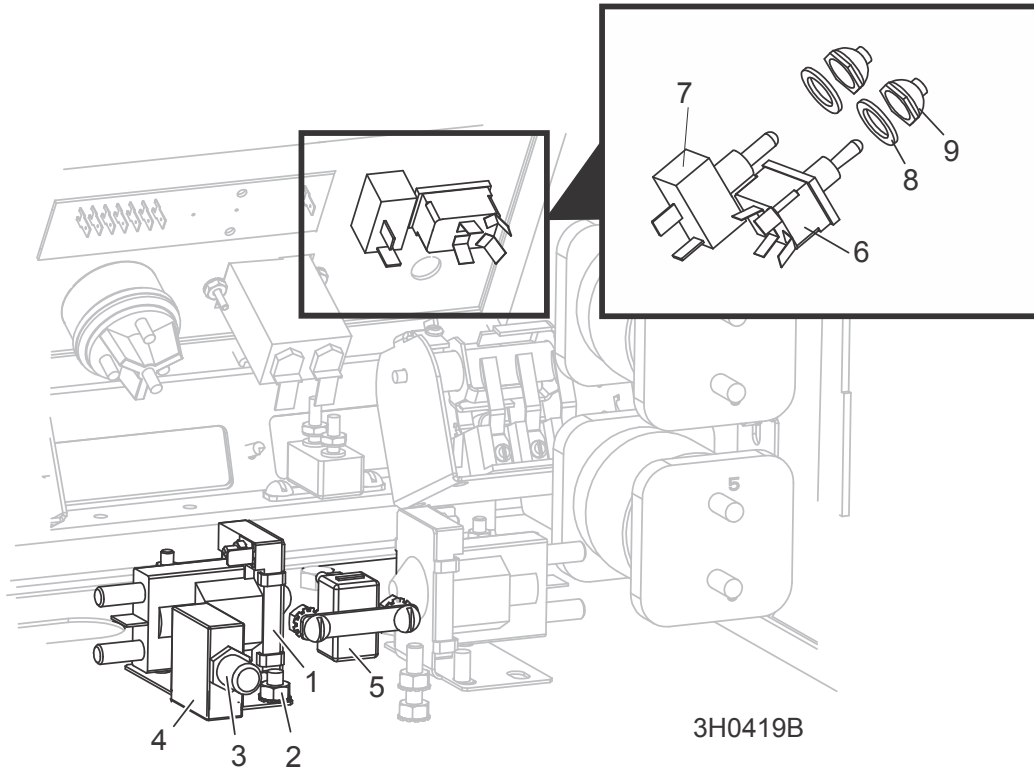

REF	DESCRIPTION (◆ Indicates Parts Available In Assemblies Only)	PART #	QTY.
	<b>CONTROL ASSEMBLY, DEBARKER (NON-REMOTE)</b>	023676	1
	<b>CONTROL ASSEMBLY, DEBARKER (REMOTE)</b>	023677	1
1	Solenoid Kit, Accessory	016372 <sup>1</sup>	1
	Solenoid, 100A 12V Cont. Duty GND	P10449	1 ◆
	Diode Assembly, Solenoid Coil Chassis GND	015426	1
2	Nut, 1/4-20 Self Locking	F05010-9	2
3	Boot, Circuit Breaker	021253	1
4	Breaker, 70 Amp Manual Reset Panel Mount	015527	1
5	Breaker, 15 Amp Manual Reset	E20430	1
6	Switch, DPDT Toggle Return Center Screw Terminal	024200	1
7	Switch, SPST Toggle Quick Connect	P03027	1
8	Washer, 1/2 x 3/4 x 1/16" Nylon	P05251-1	2
9	Boot, Toggle Switch	P02575	2

<sup>1</sup> Solenoid Kit 016372 replaces Solenoid P10449. Kit includes solenoid and replacement instructions. Diode Wire Assembly 015426 added to Solenoid Kit 016372 (8/04).

# INDEX

---

## A

alignment 3-1

---

## E

electrical information 5-1  
    component list 5-3  
    symbol diagram (non-remote) 5-1  
    symbol diagram (remote) 5-2  
    wiring diagrams (non-remote) 5-4  
    wiring diagrams (remote) 5-9  
    wiring diagrams (wireless) 5-17

---

## I

installation 2-1  
    control components (remote) 2-21  
    control components (standard) 2-14  
    debarker 2-3  
    frame mounting holes 2-2  
    lower harness 2-8

---

## M

maintenance 4-7

---

## O

operation 4-5  
    control overview 4-3  
    locking pin 4-1

---

---

## R

replacement parts 6-1  
    blade housing 6-8, 6-10  
    blade motor & horn 6-4, 6-6  
    control 6-13  
    frame 6-2  
    in/out motor 6-2  
    mechanical assembly 6-1  
    mount/lock pin 6-1  
    spring arm 6-12

---

## S

safety 1-1  
    installation & maintenance 1-1  
    operation & towing 1-2

---

## T

troubleshooting 4-10

---