

Debarker Option

Safety, Installation, Operation, Maintenance & Parts Manual

MKI for 97+ Sawmills rev. A.00 - D.04



Safety is our #1 concern! Read and understand all safety information and instructions before operating, setting up or maintaining this machine.

April 1998

Form #545

Table of Contents	Section-Page
SECTION 1 SAFETY	1-1
1.1 Installation and Maintenance.....	1-1
1.2 Operation and Towing.....	1-2
SECTION 2 DEBARKER INSTALLATION	2-1
2.1 Debarker Frame Mounting Holes.....	2-2
2.2 Debarker Installation.....	2-3
2.3 Lower Harness Installation.....	2-8
2.4 Control Component Installation.....	2-19
SECTION 3 ALIGNMENT	2-26
SECTION 4 OPERATION AND MAINTENANCE	3-1
4.1 Locking Pin Operation.....	3-1
4.2 Control Overview.....	3-2
4.3 Operation.....	3-4
4.4 Maintenance.....	3-6
4.5 Troubleshooting.....	3-8
SECTION 5 ELECTRICAL INFORMATION	4-1
5.1 Electrical Symbol Diagram.....	4-1
5.2 Electrical Component List.....	4-2

Table of Contents

Section-Page

SECTION 6	DEBARKER PARTS	5-1
6.1	Mount/Lock Pin Assembly..... <i>Rev. D.03+</i>	5-1
6.2	Mount/Lock Pin Assembly..... <i>Rev. B.00 - D.02</i>	5-2
6.3	Mount/Lock Pin Assembly..... <i>Rev. A.00</i>	5-4
6.4	Frame Assembly..... <i>Rev. B.00+</i>	5-5
6.5	Frame Assembly..... <i>Rev. A.00</i>	5-7
6.6	In/Out Motor Drive Assembly..... <i>Rev. B.00+</i>	5-9
6.7	In/Out Motor Drive Assembly..... <i>Rev. A.00</i>	5-11
6.8	Blade Motor & Horn Assembly	5-13
6.9	Debarker Control Assembly	5-16
6.10	Debarker Support Plate Retrofit	5-18
6.11	Spring Rod Assembly.....	5-19

INDEX

I

SECTION 1 SAFETY



This symbol calls your attention to instructions concerning your personal safety. Be sure to observe and follow these instructions. This symbol accompanies a signal word. The word **DANGER** indicates an imminently hazardous situation which, if not avoided, will result in death or serious injury. **WARNING** suggests a potentially hazardous situation which, if not avoided, could result in death or serious injury. **CAUTION** refers to potentially hazardous situations which, if not avoided, may result in minor or moderate injury to persons or equipment. Read all safety instructions before operating this equipment and observe all safety warnings!

1.1 Installation and Maintenance



DANGER! On electric mills, hazardous voltage inside the disconnect box, starter box, and at the electric motor can cause shock, burns, or death. Disconnect and lock out power supply before performing debarker installation! Follow all applicable electrical codes.

DANGER! Make sure all electrical installation, service and/or maintenance work is performed by a qualified electrician and is in accordance with applicable electrical codes. Failure to do so will result in serious injury or death.

DANGER! Before performing any service to this equipment, turn the key to the OFF position, remove the key, and disconnect the sawmill battery ground terminal. Failure to do so will result in serious injury or death.



WARNING! Before replacing the debarker blade, move the sawmill blade guide arm in front of the sawmill blade to cover the blade teeth. Failure to do so may result in serious injury or death.

1.2 Operation and Towing



DANGER! Make sure all guards and covers are in place and secured before operating the debarker option. Failure to do so may result in serious injury.

DANGER! Keep all persons out of the path of moving equipment when operating the debarker. Failure to do so will result in serious injury.

DANGER! Always remove the key from the control panel before preparing the debarker for towing. Failure to do so may result in serious injury.



WARNING! Debarker is ON when warning bell sounds. DO NOT disconnect the warning bell. Doing so may result in serious injury.

WARNING! If the debarker continues to run with the key switch in the OFF position, remove the negative battery terminal from the battery post.

DO NOT continue to operate the mill if the main key switch does not control debarker operation. Doing so could result in serious injury. Call Wood-Mizer customer service for more information.

2 Debarker Installation

SECTION 2 DEBARKER INSTALLATION



DANGER! On electric mills, hazardous voltage inside the disconnect box, starter box, and at the electric motor can cause shock, burns, or death. Disconnect and lock out power supply before performing debarker installation! Follow all applicable electrical codes.

DANGER! Before performing any service to this equipment, turn the key to the OFF (0) position, remove the key, and disconnect the sawmill battery ground terminal. Failure to do so will result in serious injury or death.



CAUTION! Due to various design changes and past retrofits and options, you should very carefully look your mill over to determine Debarker compatibility before beginning Debarker installation.

The Debarker Option may be installed to most sawmills with the required up/down chains and 60 amp or larger alternator systems.

See Table 2-1. Look at your sawmill up/down chains to verify they are the proper style for use with the Debarker Option. Refer to the chart below to determine if the Debarker Option may be installed on your specific sawmill.

Up/Down Chain Type	Install Debarker?	Comments
Single #40	No	The Debarker Option can only be installed on sawmills equipped with dual up/down chains (after 7/86).
Dual #40	Yes, if USA chain. See comments.	"USA" should be stamped into the side plates of the chain. If it is not, you will need to replace the existing chains with the proper specified chains. If you did not receive replacement chains with your Debarker order and find that you need them, call Wood-Mizer Customer Service at 1-800-525-8100 . Do not proceed with Debarker installation or further operation until your mill is equipped with the correct up/down chains.
#50-2	Yes	The Debarker Option can be installed on any sawmill equipped with #50-2 up/down chain (after 3/97).

TABLE 2-1

2.1 Debarker Frame Mounting Holes

IMPORTANT! Sawmills are equipped with pre-drilled Debarker mounting holes. **Verify hole locations before beginning Debarker installation. Proper hole location is imperative for safe and effective Debarker operation.**

See Figure 2-1. Sawmills built prior to March 1998 only have two debarker mounting holes pre-drilled in the saw head. You will need to drill an additional set of two holes at the dimensions indicated¹. Drill the two 13/32" diameter holes through the saw head tube and the wall of the middle blade housing.

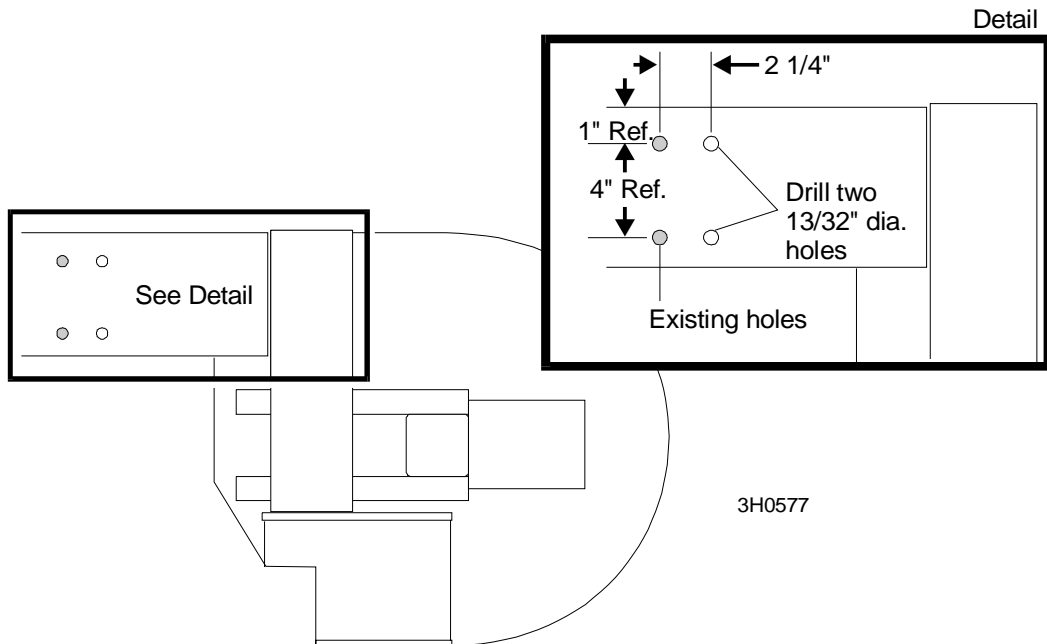

FIG. 2-1

¹ Rev. D.03 only. Previous revisions use two-bolt mount and require pad 016048 to prevent loss of debarker alignment caused by mount pivoting during operation

2 Debarker Installation

Debarker Installation

2.2 Debarker Installation

NOTE: You will not use all components of the debarker bag assembly during installation. Excess hardware is included to cover all possible mill variations and needs.

See Figure 2-2. The debarker wiring on sawmills built after 7/98 is pre-routed and secured at the debarker mounting location with a guard. This guard must be removed before the debarker can be installed.

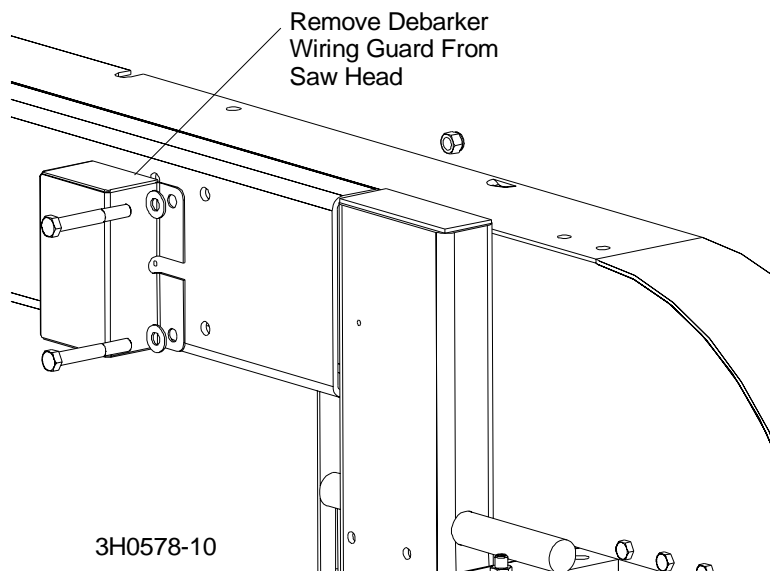

FIG. 2-2

Rev. A.00 - D.02 Only:

1. Assemble the debarker to the sawmill saw head. Align the mounting block holes and the holes in the sawhead at location B. Place the supplied pad¹ between the saw head and mounting block assembly, aligning the slots in the pad with the two mounting holes. Use the provided 3/8-16 hex nylon lock nuts to secure in place.

NOTE: When installing, make sure the blade guide wire harness is routed between the c-frame and the pivot arm.

See Figure 2-3.

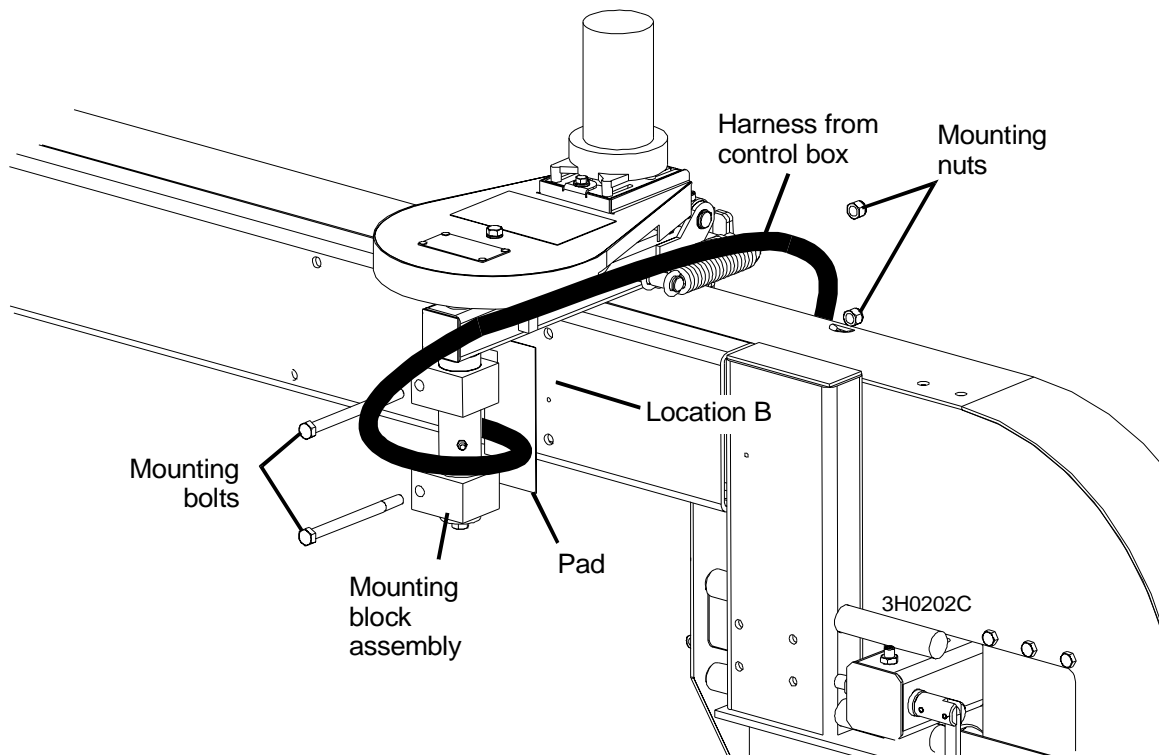

FIG. 2-3

¹ 016048 pad was added (Rev. D.02) to prevent loss of debarker alignment caused by mount pivoting during operation. Previous revision debarkers can be upgraded with pad or four-bolt mount used after Rev. D.03 ([See page 5](#)).

2

Debarker Installation

Debarker Installation

Rev. D.03 Only:

1. Open the middle blade housing cover. Remove the four pre-installed bolts and nuts from the debarker frame mounting blocks.
2. Assemble the debarker to the sawmill saw head. Align the mounting block holes and the holes in the saw head. Insert the bolts from the back of the saw head, through the debarker mounting block holes. Use the lock nuts to secure in place. Tighten the mounting bolts to 20 ft.-lbs. torque. Do not tighten the set screws in the mounting blocks until debarker alignment has been performed.

NOTE: When installing, make sure the blade guide motor wire harness is routed between the saw head and the pivot arm.

See Figure 2-4.

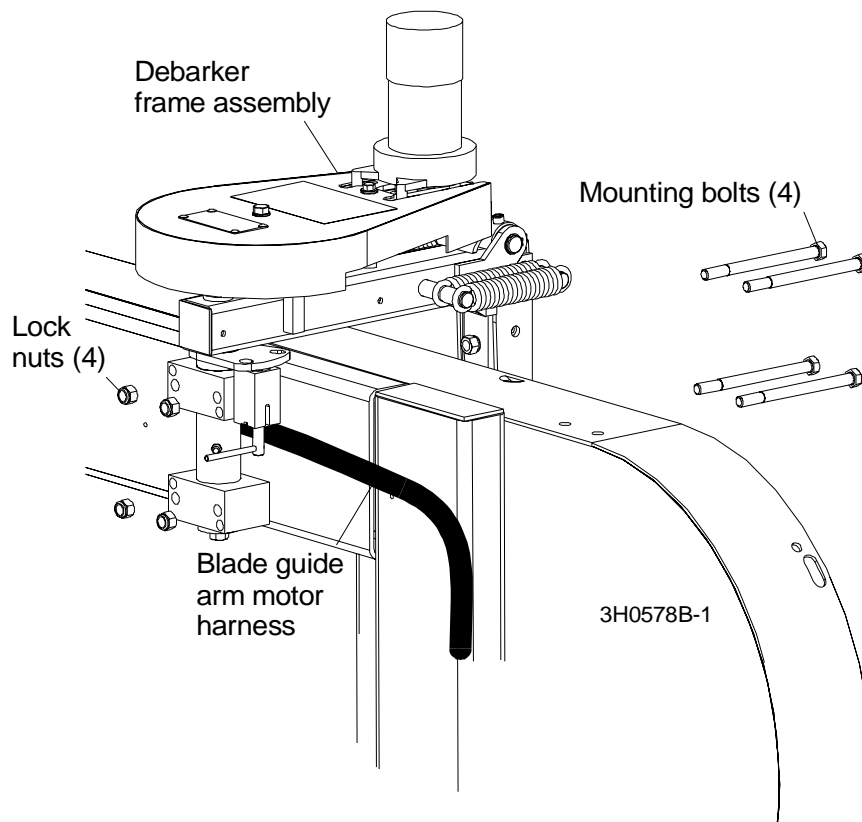

FIG. 2-4

3. Assemble the debarker cutting head to the mount plate on the frame.

Use the two provided U-bolts, 5/16" split lock washers and 5/16-18 hex nuts to secure in place.

See Figure 2-5. Install the flexible guard and guard bracket to the pivot arm guard bracket. Secure in place with the provided 1/4" flat washers, 1/4" split lock washers, and 1/4-20 x 3/4" hex head full thread bolts.

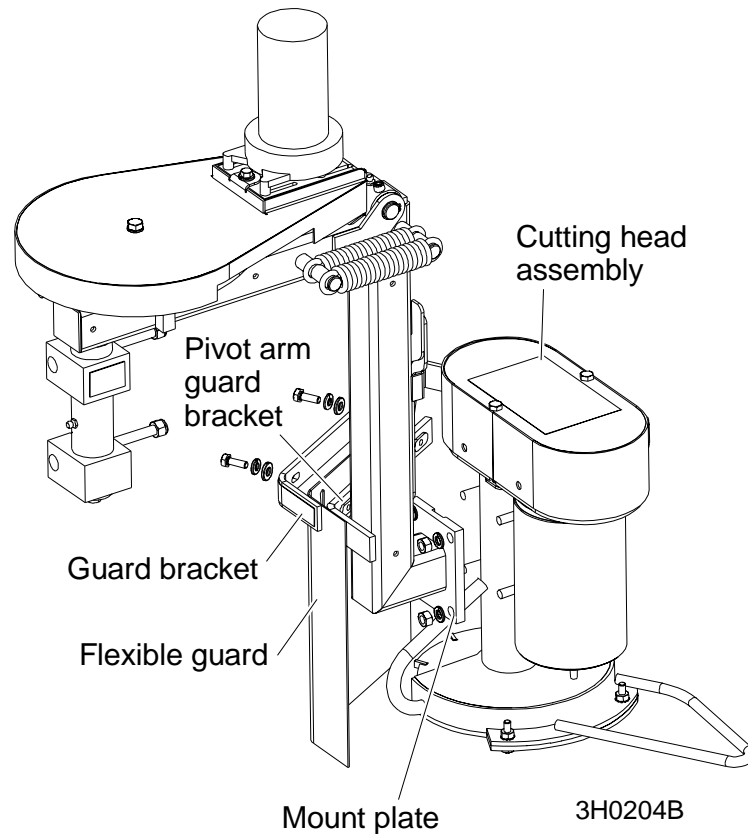

FIG. 2-5

2

Debarker Installation

Debarker Installation

4. Install the spring arm assembly to the debarker in/out pulley using the 3/8-16 x 1 3/4" hex head bolt, two flat washers, and two lock nuts provided.
5. Remove the idle-side blade housing cover. Align the two holes in the spring arm bracket with the two holes in the top of the saw head blade housing. Use the provided 3/8-16 x 1" hex head bolts and 3/8-16 nylon lock nuts to secure the spring arm bracket saw head. Replace the blade housing cover. Close the middle blade housing cover.

See Figure 2-6.

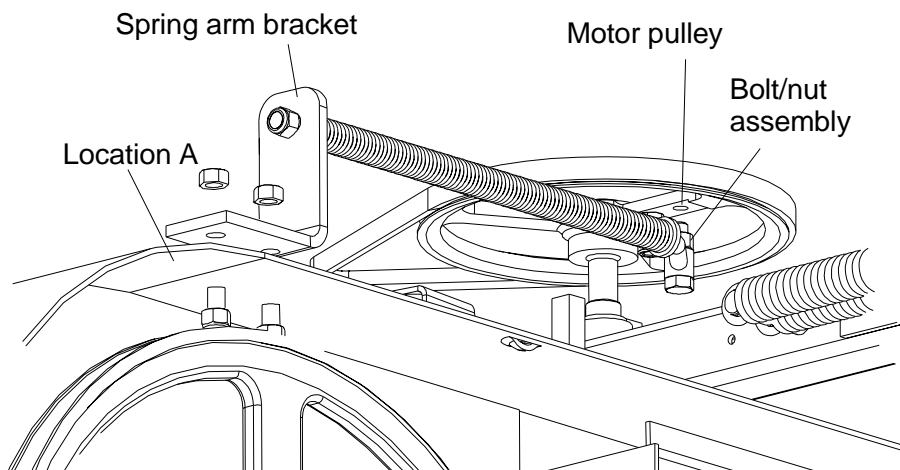

FIG. 2-6

6. Replace the existing middle cover wing nut with the provided middle cover wing nut.

See Figure 2-7.

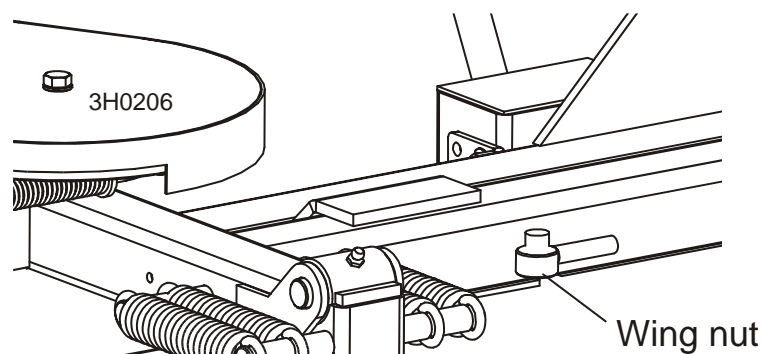

FIG. 2-7

2.3 Lower Harness Installation



DANGER! On electric mills, hazardous voltage inside the disconnect box, starter box, and at the electric motor can cause shock, burns, or death. Disconnect and lock out power! Follow all applicable electrical codes.

DANGER! Before performing any service to this equipment, turn the key to the OFF (0) position, remove the key, and disconnect the sawmill battery ground terminal. Failure to do so will result in serious injury or death.



IMPORTANT! Avoid pinch and pivot points, unnecessary wire bending and open spaces where the wire could get caught by a log, etc. If you have any questions, call Wood-Mizer customer service.

2

Debarker Installation

Lower Harness Installation

Rev. A.00 Debarker Only:

1. Locate the lower motor harness on the debarker control box. Route the lower harness under and around the sawmill motor mount using provided clamps and 1/4-20 x 7/8" hex head grade 2 bolts as needed. Then route the harness between the debarker pivot arm and the c-frame as shown. Loop the harness up and over the c-frame, routing it underneath the spring arm, and along the debarker pivot arm. Leave the wire in this position for now.

See Figure 2-8.

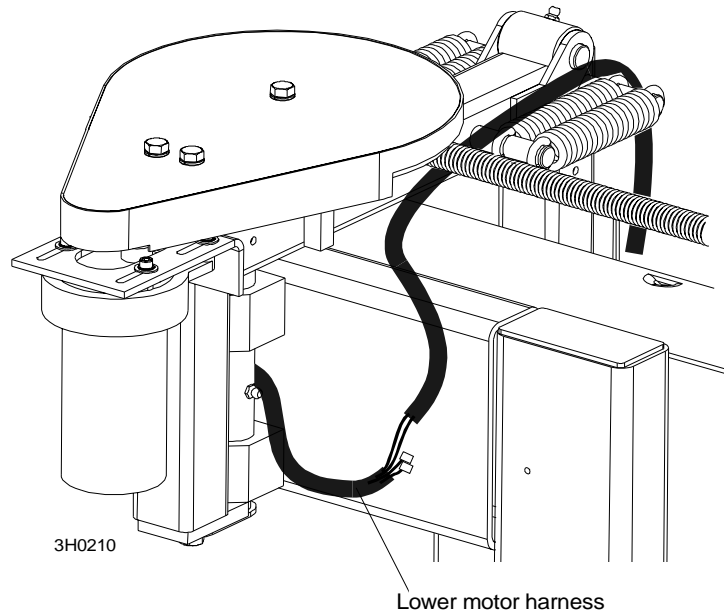

FIG. 2-8

2. Install the provided 20" piece of tubing over the red and black debarker pivot arm drive motor wires. Strip the end of the black drive motor wire and install a provided 1/4" male quick connect terminal.

See Figure 2-9.

3. Cut the red drive motor wire so it is 1" shorter than the black drive motor wire, strip the end, and install a provided 1/4" male quick connect terminal. This will allow the wires to be neatly bundled together and wrapped later.

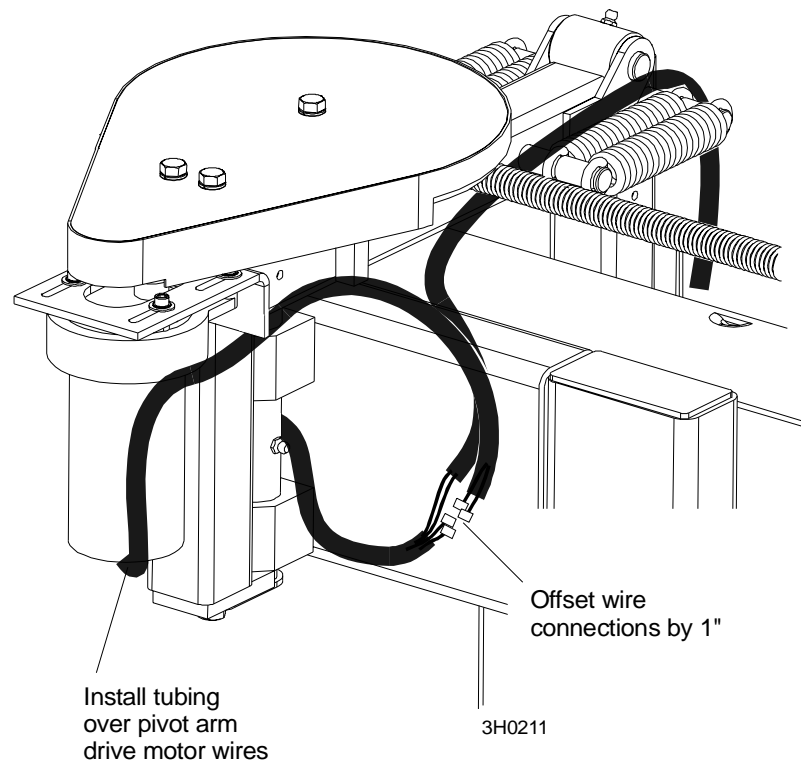

FIG. 2-9

4. Connect the red drive motor wire to the red lower harness wire. Connect the black drive motor wire to the black lower harness wire.

2

Debarker Installation

Lower Harness Installation

5. Form the drive motor wire tubing in a loop as shown. Use two of the provided wire ties to attach the tubing to the side of the drive motor.

See Figure 2-10.

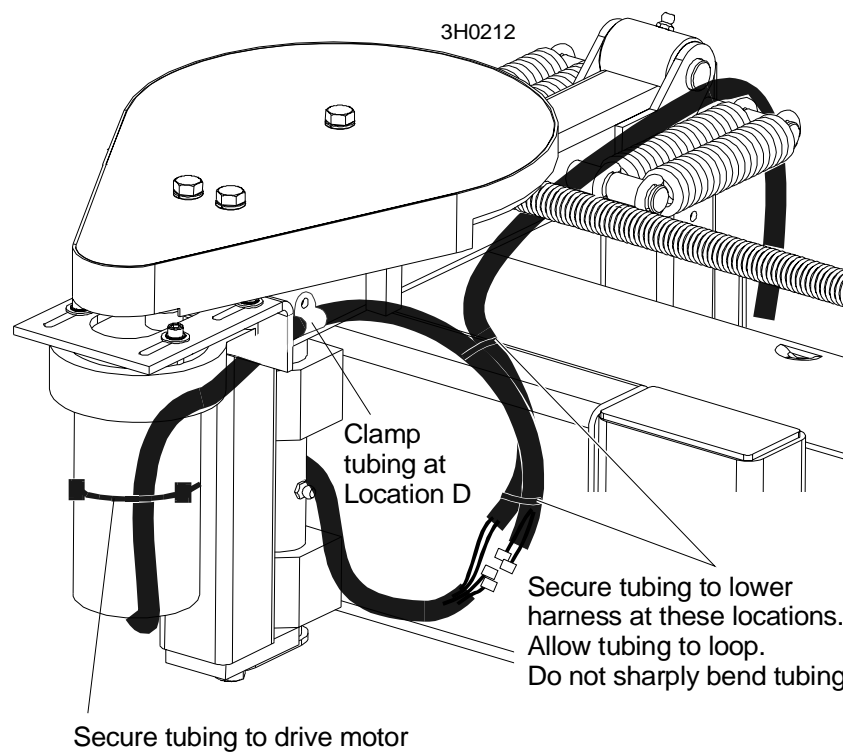

FIG. 2-10

6. Use a provided clamp and 1/4-20 x 1/2" hex head bolt to attach the tubing to location D on the pivot arm.
7. Use two wire ties to secure the tubing to the lower harness at two locations as shown. Be sure to retain the tubing loop to allow the debarker arm to move and pivot in full range and also to prevent undue wire stress from sharply bent wires.
8. Wrap the exposed wires and connections with electrical tape. Tuck the wrapped portion of the harness between the pivot arm and c-frame.

9. Making sure to leave the loop, use provided clamps and 1/4-20 x 7/8" hex head bolts to secure the lower harness to the pivot arm at locations E and F and G as shown.

See Figure 2-11.

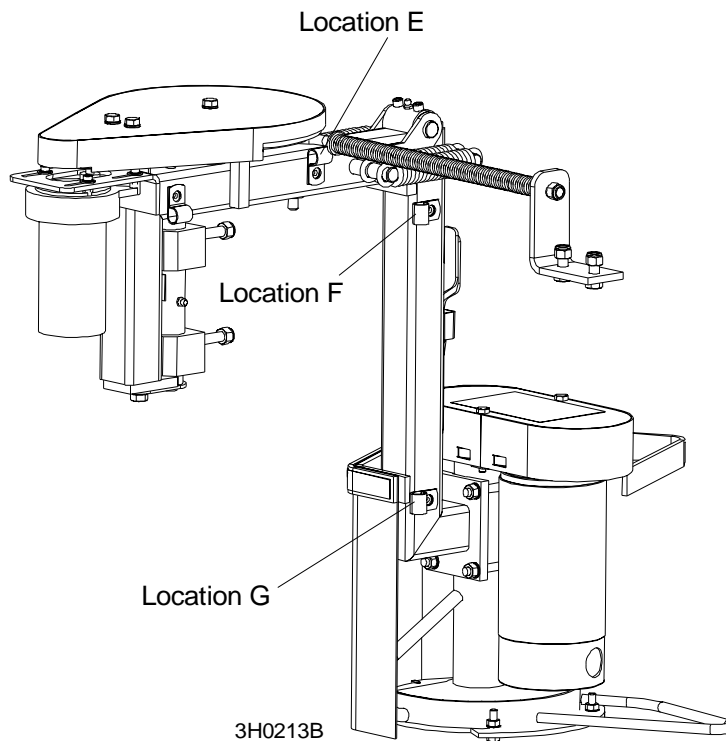

FIG. 2-11

10. Next, connect the lower harness wires to the terminals at the bottom of the debarker cutting motor. The harness tubing and wires will be longer than necessary (to allow for differences in routing). Route the wires to the terminals. Cut excess length.
11. Route the wires from the warning bell down the side of the motor to the terminals. Cut excess length.
12. Route the black motor wire from the lower harness and the black wire from the warning bell through one of the provided rubber boots.
13. Strip the end of the black motor wire and install a 1/4" 8 gauge ring terminal. Strip the end of the black warning bell wire and install a 1/4" 14-16 gauge ring terminal. To install the 14-16 gauge ring terminal, fold the stripped end of the wire over the insulation, install the ring terminal and crimp in place.

2

Debarker Installation

Lower Harness Installation

14. Connect the ring terminals to motor terminal A using a supplied 1/4-20 self-locking nut.



IMPORTANT! Make sure that the ring terminals do not touch motor body.

15. Route the red motor wire from the lower harness and the red wire from the warning horn through one of the provided rubber boots.
16. Strip the end of the red motor wire and install a 1/4" 8 gauge ring terminal. Strip the end of the red warning horn wire and install a 1/4" 14-16 gauge ring terminal. To install the 14-16 gauge ring terminal, fold the stripped end of the wire over the insulation, install the ring terminal and crimp in place.
17. Connect the ring terminals to motor terminal B using a supplied 1/4-20 self-locking nut.



IMPORTANT! Make sure that the ring terminals do not touch the motor body.

18. Slide the rubber boots over the ring terminals and motor posts to protect connections.
19. Use a provided wire tie to secure the horn wires to the lower harness approximately 3" from the motor terminals as shown.

See Figure 2-12.

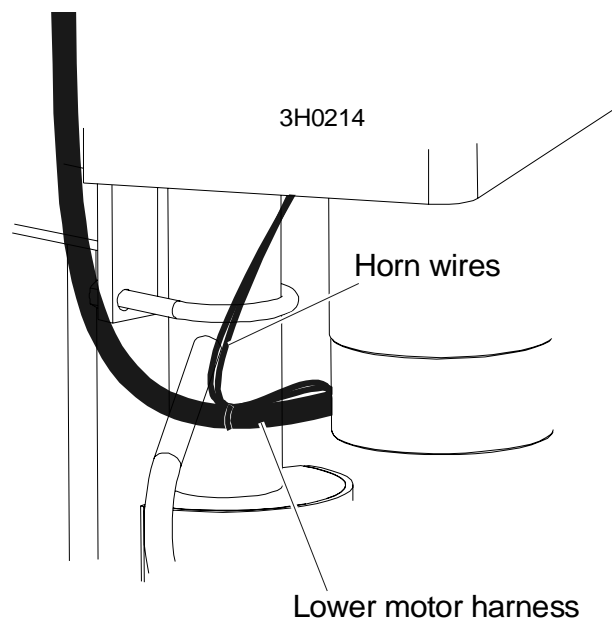

FIG. 2-12

Rev. B.00 - C.01 Debarker Only:

1. Locate the lower motor harness on the debarker control box. Route the lower harness under and around the sawmill motor mount using provided clamps and 1/4-20 x 7/8" hex head grade 2 bolts as needed.

Then route the harness between the debarker pivot arm and the c-frame as shown. Loop the harness up and over the c-frame, routing it through the cable clamps, underneath the spring arm, and around the spring mount pin. Use the provided 1/4-20 x 1/2" hex head bolt to install the first cable clamp. Leave the wire in this position for now.

Position the split area of the cable about 3" behind the second cable clamp.

See Figure 2-13.

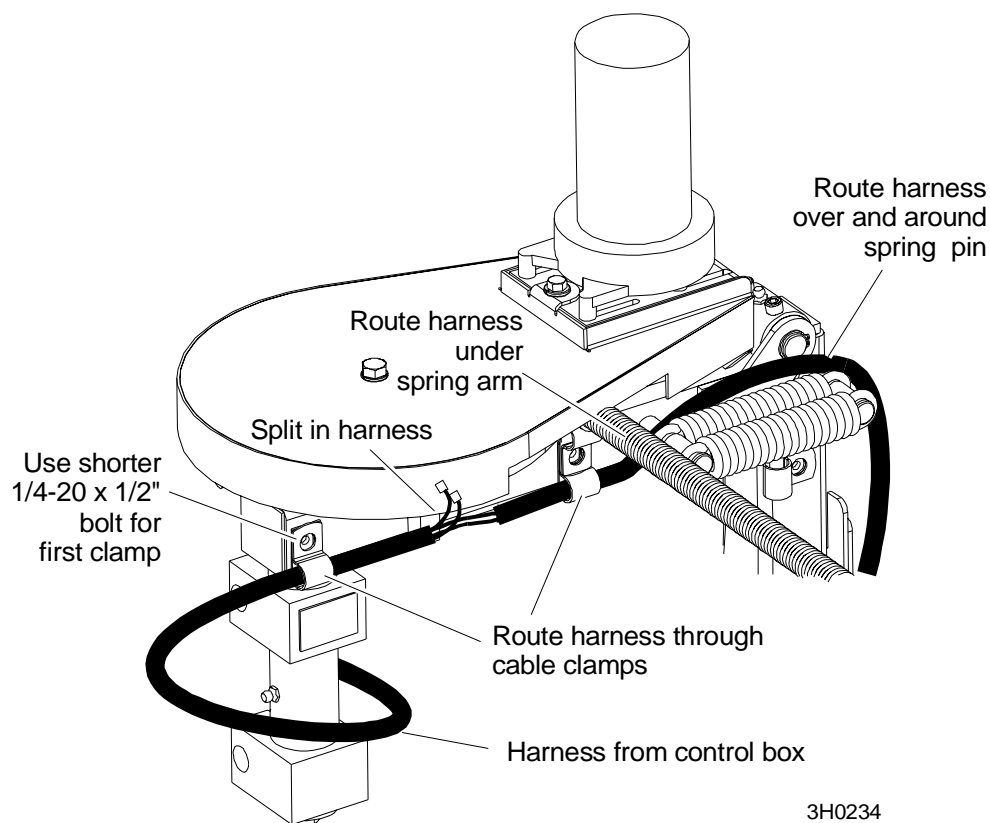

FIG. 2-13

2

Debarker Installation

Lower Harness Installation

2. Install the provided 20" piece of tubing over the red and black debarker pivot arm drive motor wires.
3. Route the cable underneath the spring arm, through the cable clamp, to the split in the control box cable.

See Figure 2-14.

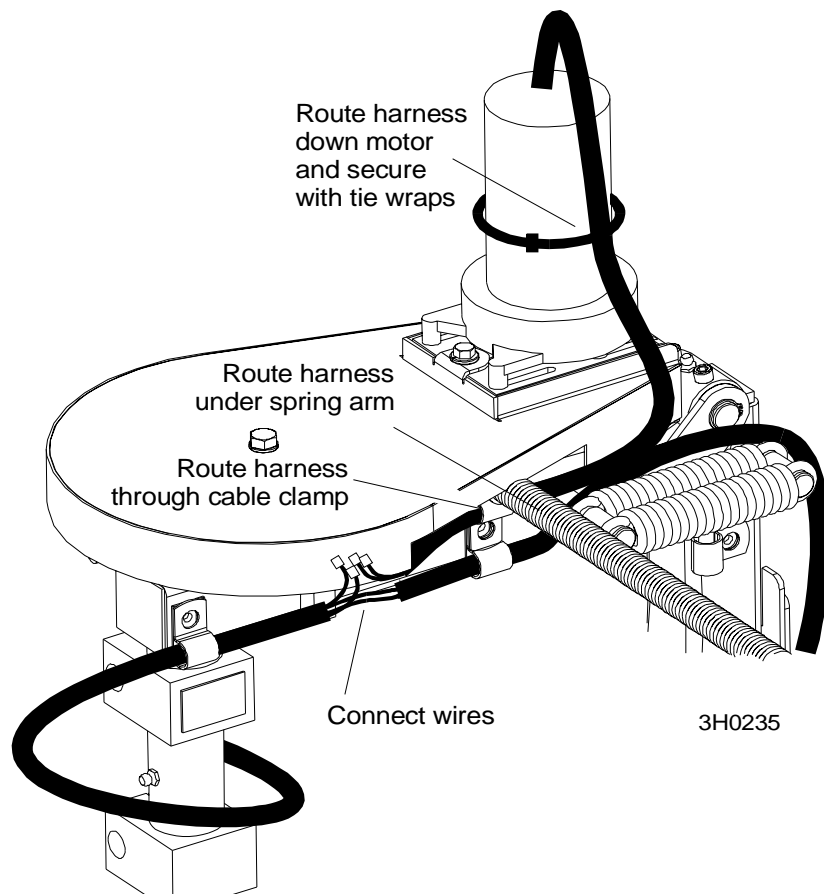

FIG. 2-14

4. Use 2 of the provided wire ties to attach the tubing to the side of the drive motor.
5. Strip the end of the black drive motor wire and install a provided 1/4" male quick connect terminal.

Cut the red drive motor wire so it is 1" shorter than the black drive motor wire, strip the end, and install a provided 1/4" male quick connect terminal. This will allow the wires to be neatly bundled together and wrapped later.

6. Connect the red drive motor wire to the red lower harness wire. Connect the black drive motor wire to the black lower harness wire.
7. Wrap the wire connections with electrical tape. Route the lower harness through the cable clamp on the vertical frame tube. Be sure to retain the tubing loop to allow the debarker arm to move and pivot in full range and also to prevent undue wire stress from sharply bent wires.

See Figure 2-15.

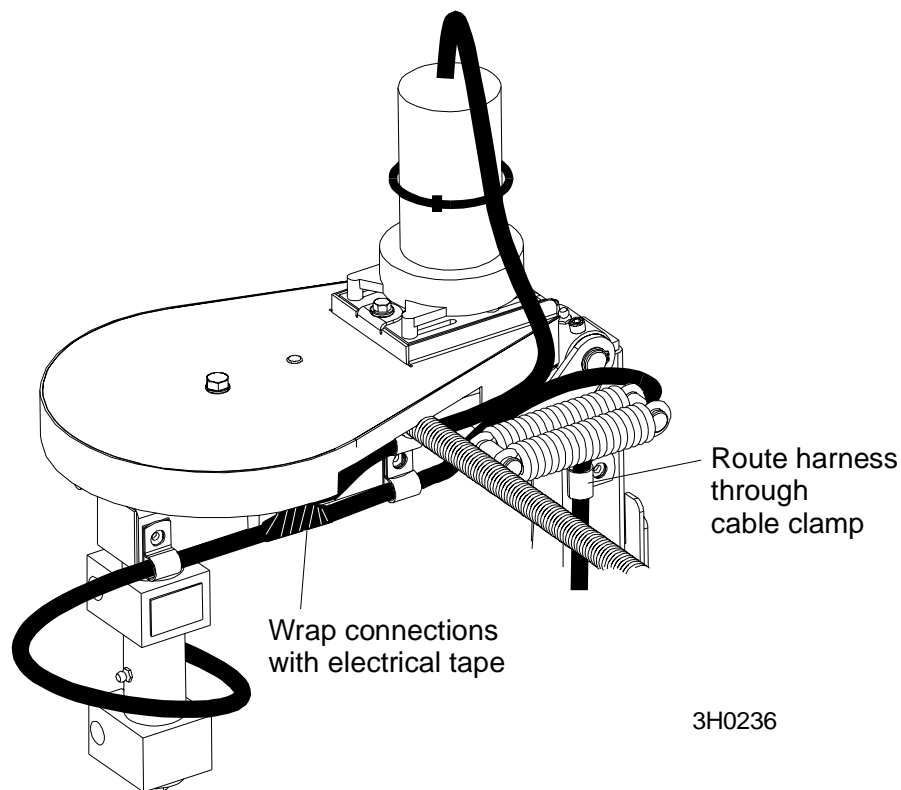

FIG. 2-15

2

Debarker Installation

Lower Harness Installation

8. Route the cable down through the bottom cable clamp and to the blade motor terminals.
9. Route the warning bell wires along the cable and secure with a tie wrap. Use a provided wire tie to secure the bell wires to the lower harness approximately 3" from the motor terminals as shown.

See Figure 2-16.

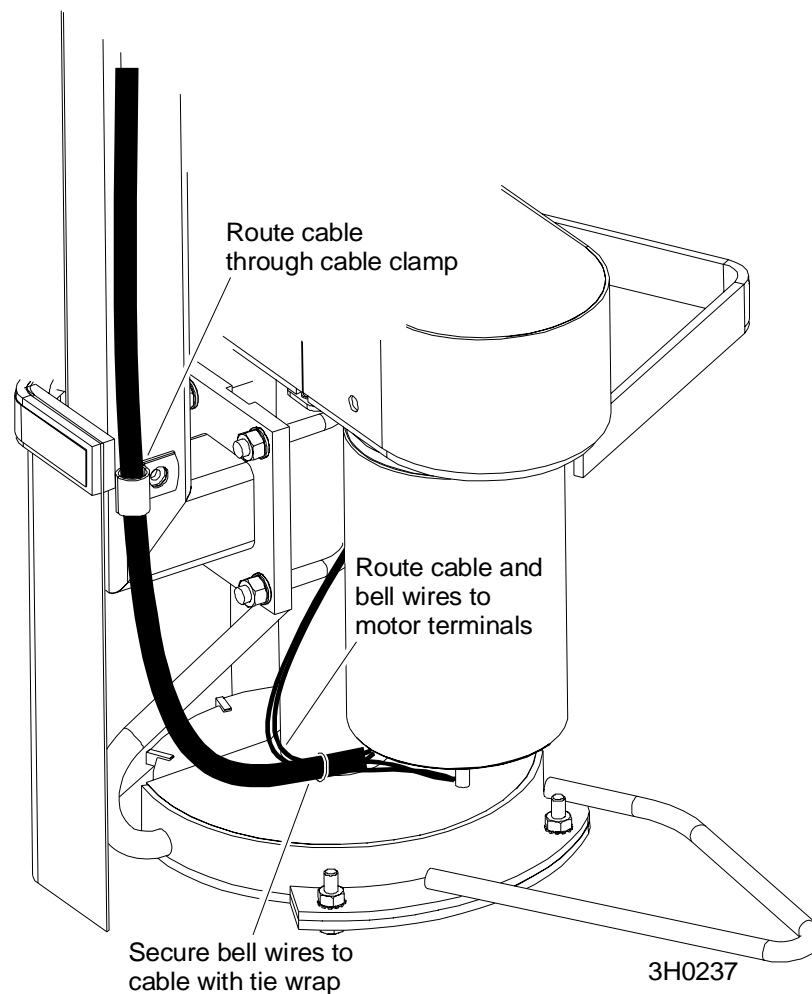

FIG. 2-16

10. Next, connect the lower harness wires to the terminals at the bottom of the debarker cutting motor. The harness tubing and wires will be longer than necessary (to allow for differences in routing). Cut excess length.
11. Route the black motor wire from the lower harness and the black wire from the warning bell through one of the provided rubber boots.

12. Strip the end of the black motor wire and install a 1/4" 8 gauge ring terminal. Strip the end of the black warning bell wire and install a 1/4" 14-16 gauge ring terminal. To install the 14-16 gauge ring terminal, fold the stripped end of the wire over the insulation, install the ring terminal and crimp in place.
13. Connect the ring terminals to motor terminal A using a supplied 1/4-20 self-locking nut.



IMPORTANT! Make sure that the ring terminals do not touch motor body.

14. Route the red motor wire from the lower harness and the red wire from the warning bell through one of the provided rubber boots.
15. Strip the end of the red motor wire and install a 1/4" 8 gauge ring terminal. Strip the end of the red warning bell wire and install a 1/4" 14-16 gauge ring terminal. To install the 14-16 gauge ring terminal, fold the stripped end of the wire over the insulation, install the ring terminal and crimp in place.
16. Connect the ring terminals to motor terminal B using a supplied 1/4-20 self-locking nut.



IMPORTANT! Make sure that the ring terminals do not touch motor body.

17. Slide the rubber boots over the ring terminals and motor posts to protect connections.

2.4 Control Component Installation



DANGER! On electric mills, hazardous voltage inside the disconnect box, starter box, and at the electric motor can cause shock, burns, or death. Disconnect and lock out power! Follow all applicable electrical codes.

DANGER! Before performing any service to this equipment, turn the key to the OFF (0) position, remove the key, and disconnect the sawmill battery ground terminal. Failure to do so will result in serious injury or death.

See SECTION 5 for the appropriate wiring diagram to aid in installation.

1. Remove the side, front and rear panels (leave wire connections) from the control box.
2. Locate the solenoid mounting studs in the control box. Place the solenoid on the mounting studs and place the diode assembly ring terminal over one of the studs. Use the two 1/4-20 self-locking nuts provided to secure in place.

See Figure 2-17.

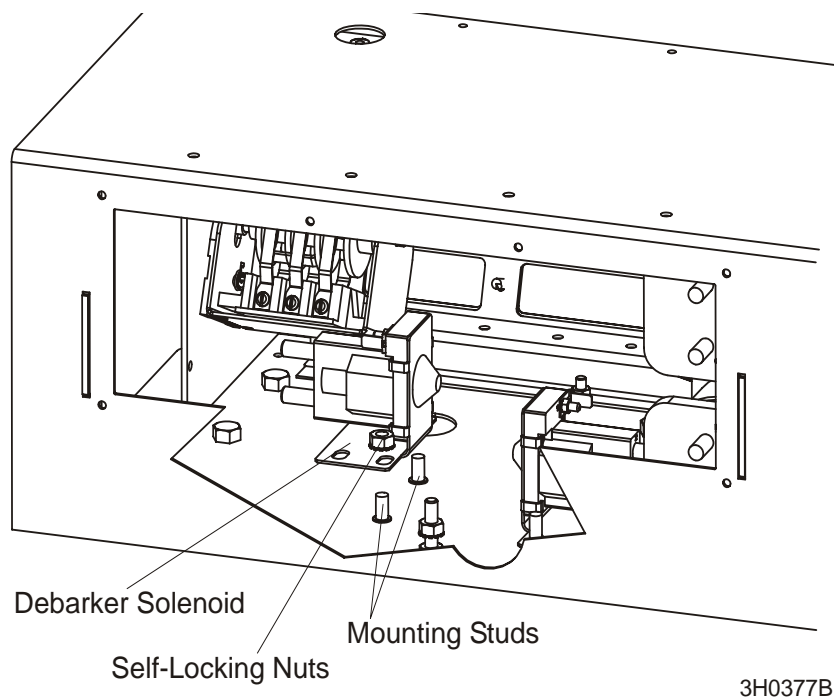

FIG. 2-17

3. Remove the two small bolts and nuts and the one large bolt and nut from the back of the control box.
4. Locate the bundle of wires on the floor of the sawmill control box. Make sure the large black #24 wire is connected to the rear ground stud. Connect the large red #23 wire to the empty terminal on the provided 50 amp breaker. Do not overtighten this connection. Overtightening could cause component breakage.
5. Install the 50 amp breaker and rubber boot to the large hole on the back of the control box. Be sure the breaker terminals do not touch any other components or wires inside the control box.
6. Install the provided 15 amp breaker to the two small holes in the back of the control box (position the breaker so the reset tab is near the rear opening of the control box). Use the existing screws and nuts (removed earlier) to secure in place.

See Figure 2-18.

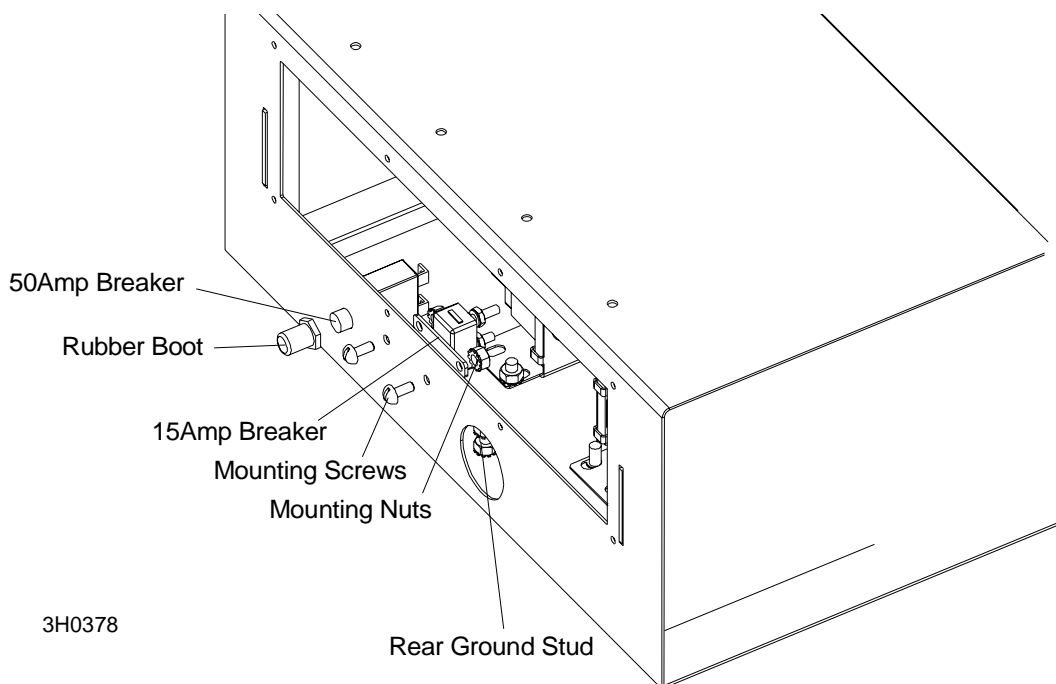

FIG. 2-18

2 Debarker Installation

Control Component Installation

- Using the back side of the front panel for a guideline, cut out holes in the front panel lexan decal for the debarker switches. Install the provided toggle switches, 1/16" nylon washers, and rubber boots in place as shown.

See Figure 2-19.

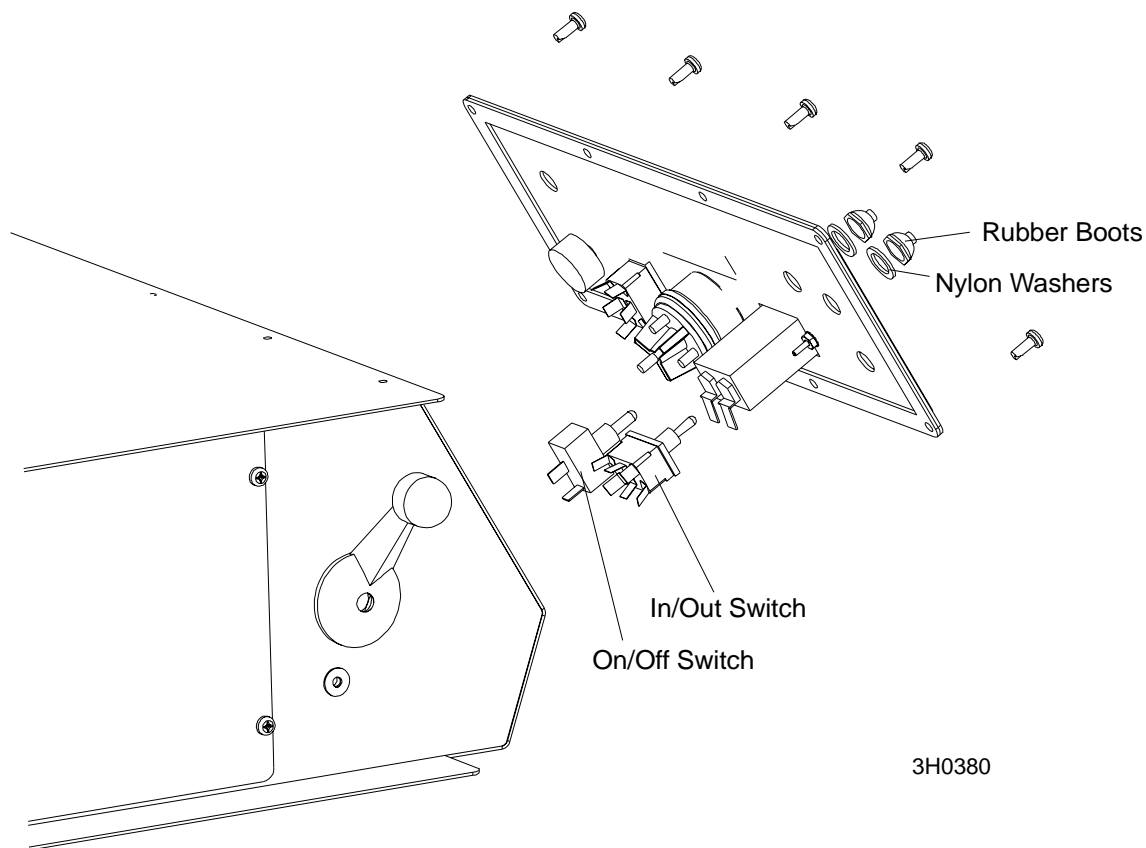

FIG. 2-19

8. Connect the red #205 wire from the 15 amp breaker to the ACC post on the key switch.
9. Make sure the red #206 wire from the 15 amp breaker to the debarker in/out switch is connected.
10. Connect the red #202 wire from the debarker solenoid to the DBKR terminal on the LED board.
11. Make sure the red #201 wire from the small terminal on the debarker solenoid to the debarker on/off switch is connected.
12. Connect the red #203 wire from debarker solenoid to the BAT post of the key switch.
13. Make sure the red #204 wire from the bottom debarker solenoid terminal to the 50 Amp breaker is connected.

See Figure 2-20. Box housing removed for clarity. Only wires referred to above are shown. Standard control box shown, Super model control differs slightly.

2

Debarker Installation Control Component Installation

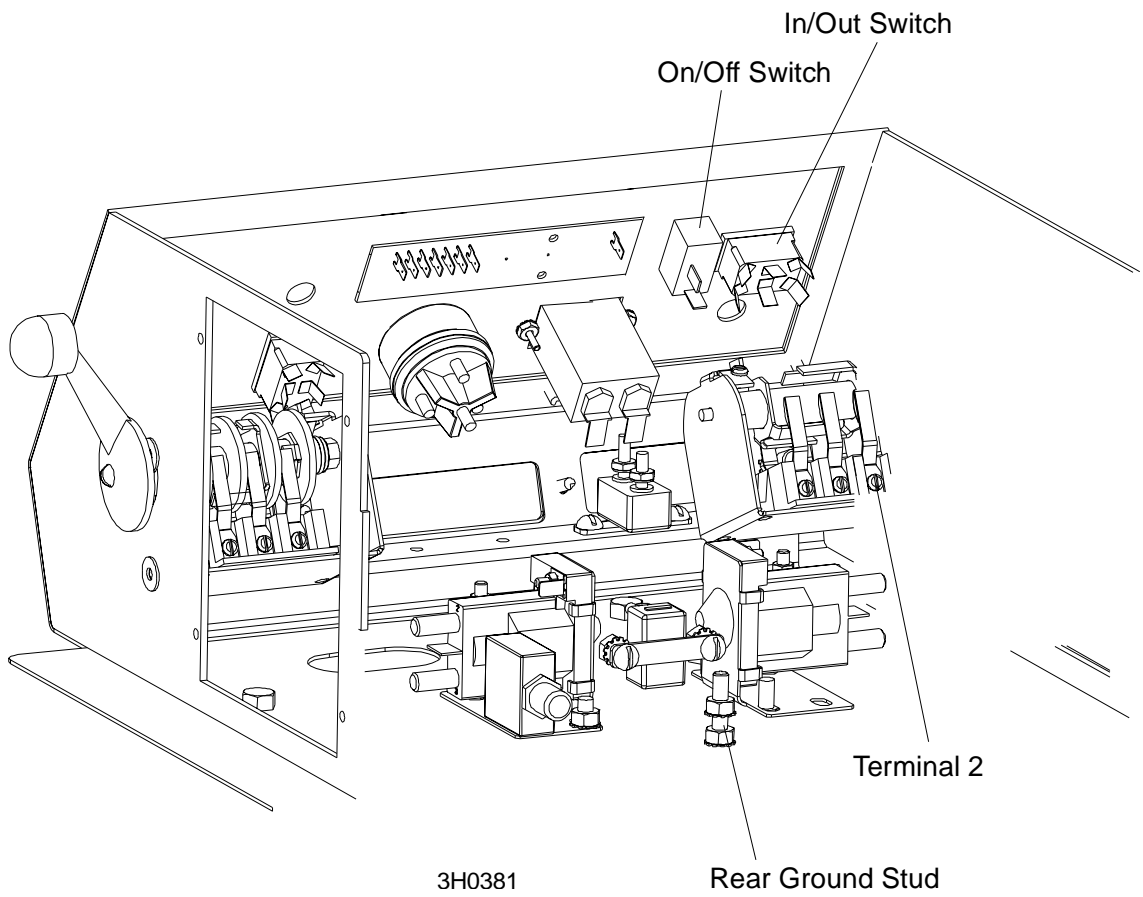

FIG. 2-20

14. Connect the red #200 wire from the debarker on/off switch to the sawmill control:

Connect red wire #200 to terminal #2 of the power feed drum switch. **NOTE:** Some sawmills are equipped with a short red wire connected to terminal #2 of the power feed drum switch. If so, connect debarker wire #200 to the end of the short wire with the provided #10 screw, washer and lock nut. Wrap the connection with the provided piece of rubber tubing and secure with a tie wrap. If no short wire exists, connect debarker wire #200 directly to power feed drum switch terminal #2.

See Figure 2-21.

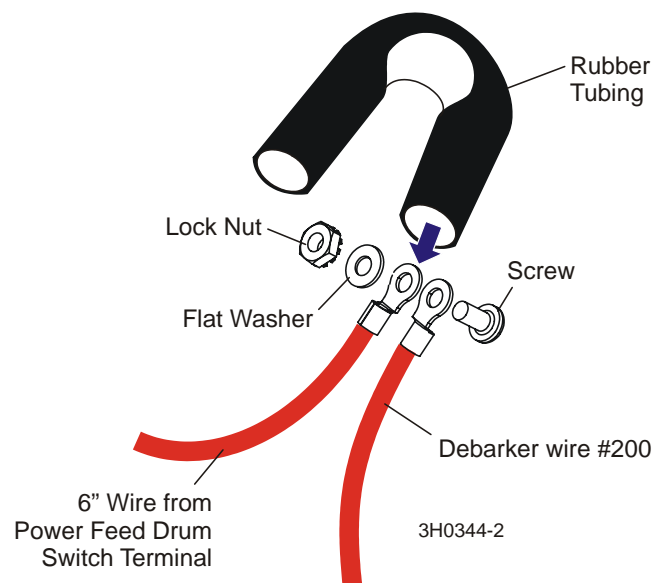

FIG. 2-21

2

Debarker Installation

Control Component Installation

15. Connect the black #207 wire from the debarker in/out switch to the rear ground stud.
16. Locate the bundle of wires on the floor of the sawmill control box. Make sure the debarker in/out switch is oriented horizontally as shown.
17. Connect the small red #21 wire to the debarker in/out switch bottom left terminal.
18. Connect the small black #22 wire to the debarker in/out switch top left terminal.

See Figure 2-22. Box housing removed for clarity. Only wires referred to above are shown. Standard control box shown, Super model control differs slightly.

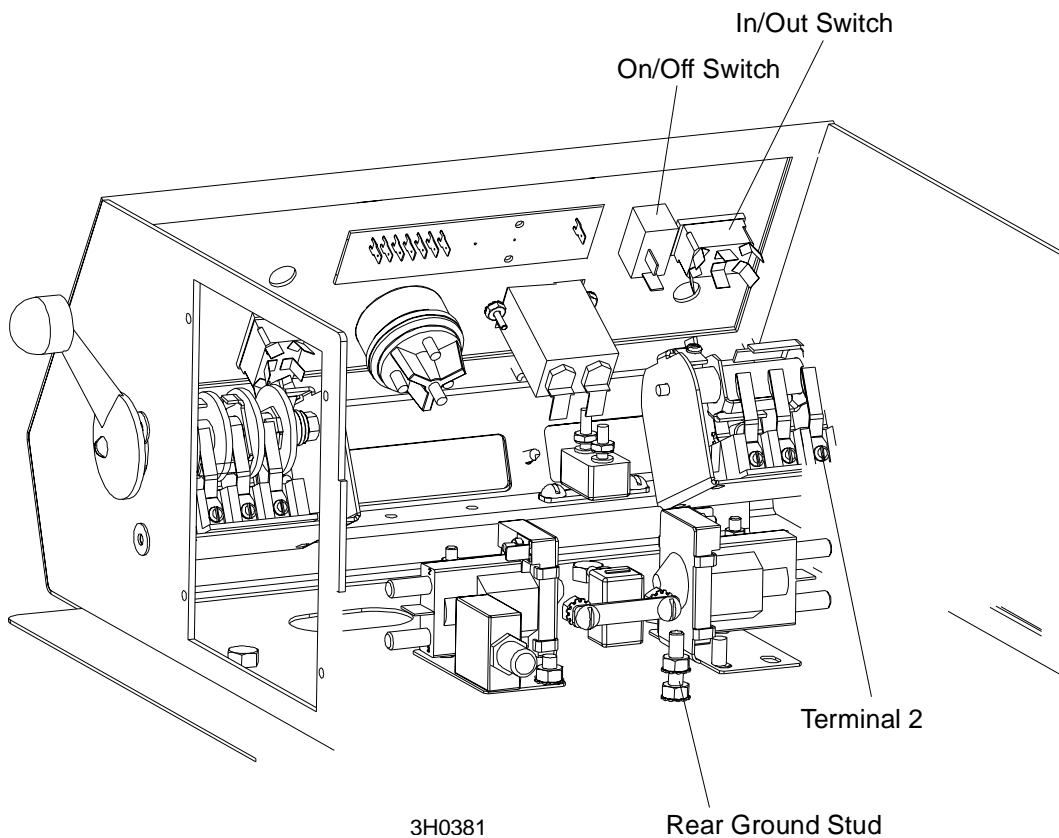

FIG. 2-22

19. Reinstall the front and rear panels, side panel, and control box top cover to the control box.

SECTION 3 ALIGNMENT



DANGER! Before performing any service to this equipment, turn the key to the OFF (0) position and remove the key. Failure to do so will result in serious injury or death.

The debarker blade should be aligned to the sawmill blade to insure proper operation. The debarker blade should be parallel with and aligned vertically with the sawmill blade.

1. Turn the key to ACC (3) and use the debarker in/out switch to move the debarker all the way in. Turn the key to OFF (0) and remove the key. This will prevent the debarker from being turned on while performing alignment procedures.
2. Check the squareness of the debarker with the sawmill blade. Adjust the debarker mounts if necessary until the debarker is square with the sawmill blade.

Loosen the four debarker mounting bolts and use a mallet to adjust the mounting blocks. The mounting holes are oversized to allow small adjustments of the debarker. Tilt the debarker mount until the debarker is square with the sawmill blade.

Reighten the debarker mounting bolts to 20 ft.-lbs. torque. Tighten the two set screws in the mounting block holes to secure the debarker in its aligned position.

2 Debarker Installation

See Figure 3-1.

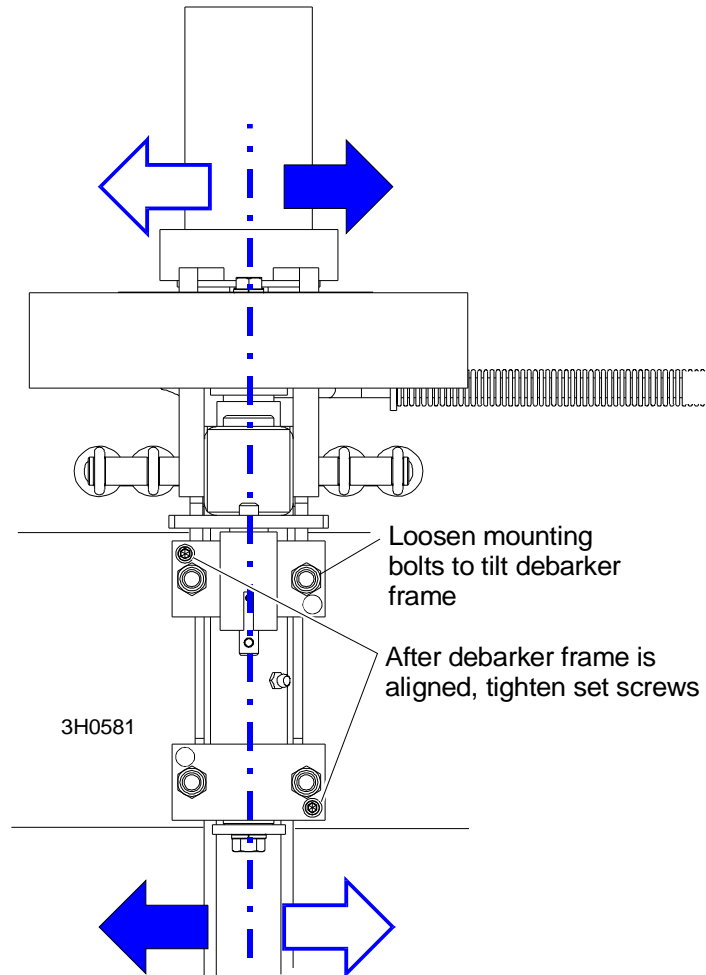

FIG. 3-1

3. Clip the blade guide alignment tool to the sawmill blade. Make sure the tool lies flat on the blade and does not contact a tooth that could cause it to angle.

See Figure 3-2.

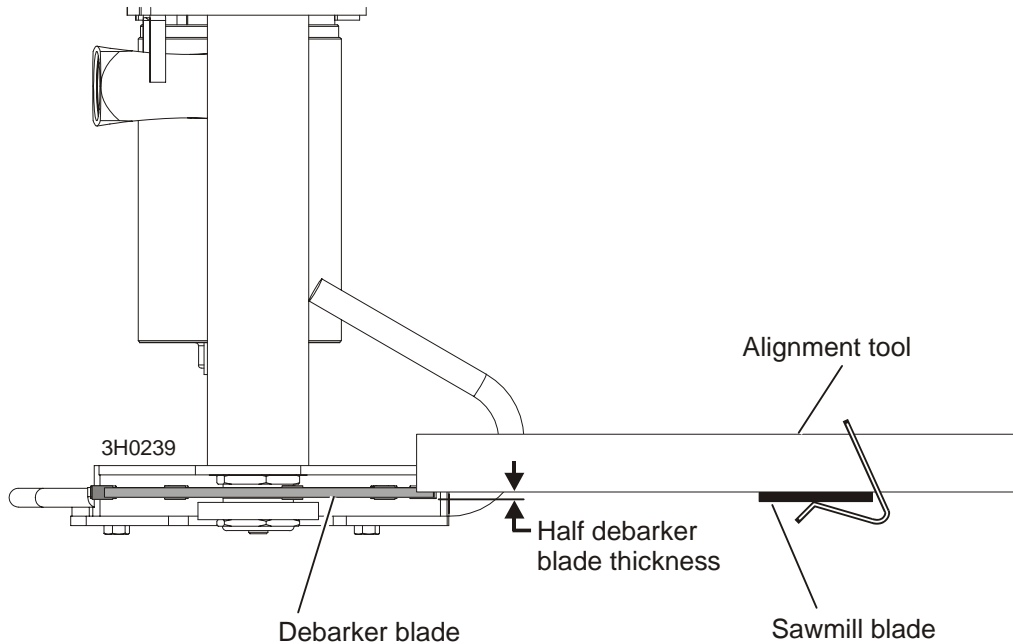

FIG. 3-2

4. Check the height of the debarker blade against the alignment tool. The bottom edge of the tool should align with the center of the debarker blade.

To adjust the blade up or down, loosen the debarker head U-bolts. Move the head assembly up or down until the blade is centered with the alignment tool and retighten the U-bolts.

5. Align the forward fence parallel to the sawmill bed main tube as shown.

2

Debarker Installation

See Figure 3-3.

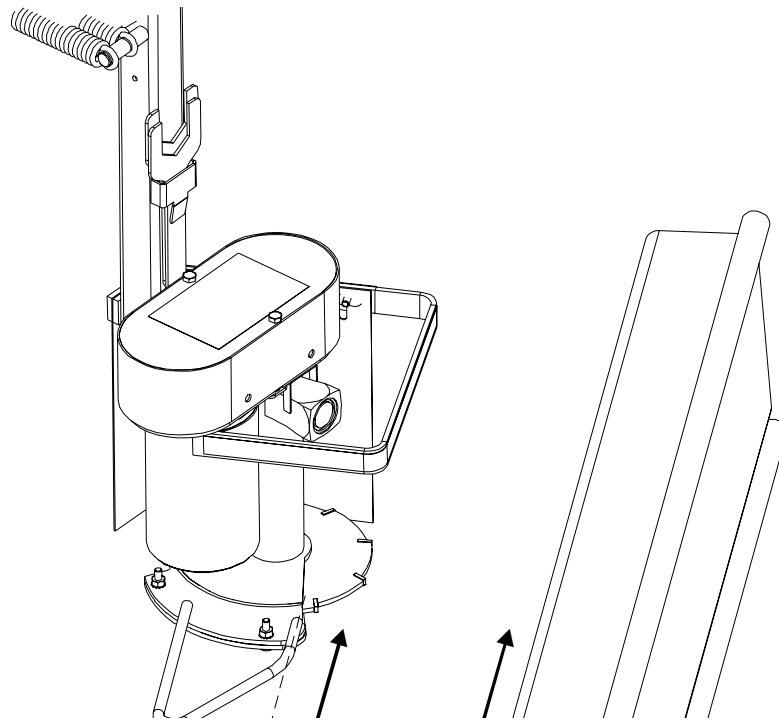

FIG. 3-3

To adjust, loosen the cutting head U-bolts and pivot the head. Be sure to maintain the height adjustment made in the previous step. Retighten the U-bolts.

Rev. D.03+ Only

6. Insert the key and use the debarker in/out switch to move the debarker all the way out. Turn the key to OFF (0) and remove the key.
7. Move the blade guide alignment tool on the sawmill blade and check the position of the debarker blade against the tool. If the debarker blade is not centered with the tool, readjust the debarker mounting bolts to adjust the debarker assembly parallel to the blade.

SECTION 4 OPERATION AND MAINTENANCE

4.1 Locking Pin Operation

1. Before towing the sawmill, engage the travel locking pin to prevent the debarker from swinging freely during towing. To do this, run the debarker all the way in.
2. Remove the key from the control panel. Manually pivot the debarker outward until the safety pin is located directly above the hole in the sawmill c-frame.



DANGER! Always remove the key from the control panel before preparing the debarker for towing. Failure to do so may result in serious injury.

3. Pull up on the locking pin, rotate and release. The pin should drop down into the c-frame hole.

See Figure 4-1.

To disengage the pin after mill towing, pull the pin up and rotate to keep in place.

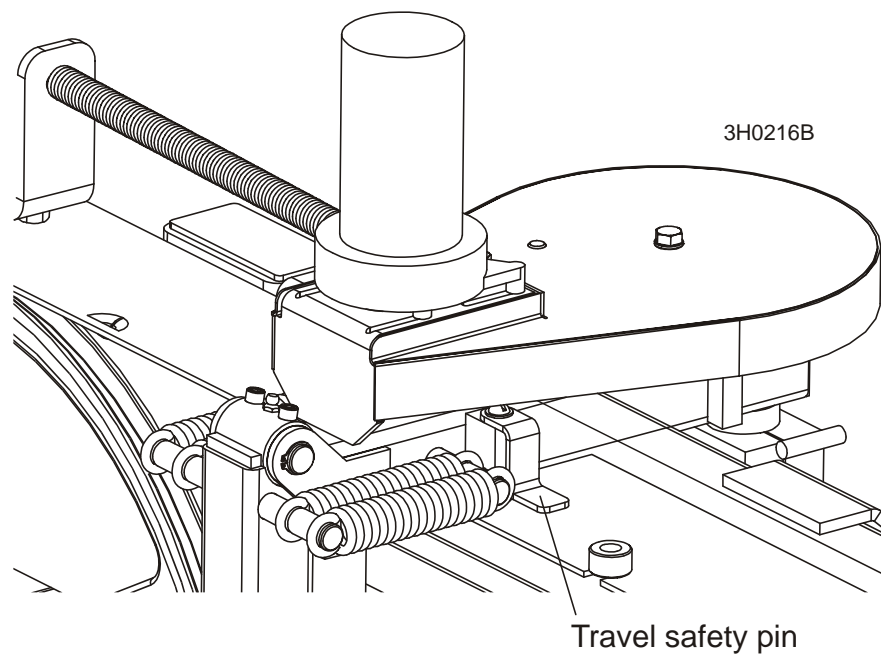

FIG. 4-1

4.2 Control Overview

The Debarker Option allows you to remove bark from logs ahead of the bandsaw blade. This prevents the bandsaw blade from contacting dirt, sand, or other debris in the bark that can dull the blade.

See Figure 4-2. The debarker control includes two toggle switches, an indicator light, and circuit breakers with manual reset.

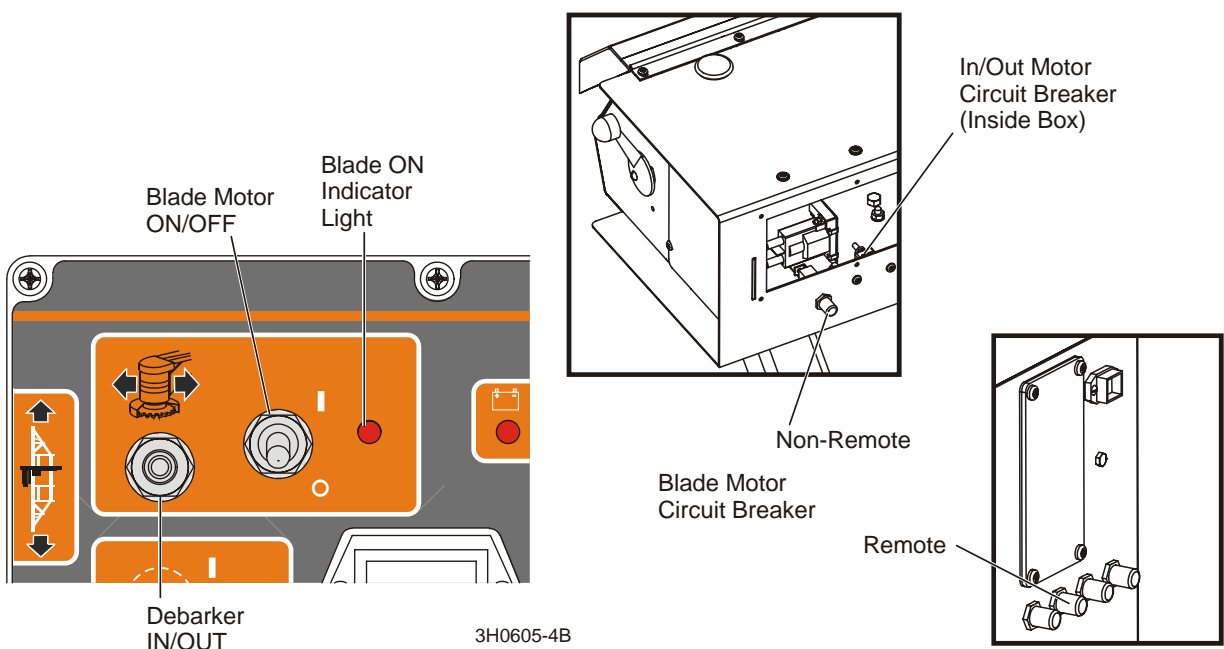

FIG. 4-2

- The Debarker IN/OUT toggle switch controls the debarker in/out motor to move the debarker cutting head toward or away from the log. The sawmill key switch must be on before the in/out function can be performed.
- The Blade Motor ON/OFF toggle switch turns the blade motor on to start the debarker blade. The sawmill key switch must be on and the sawmill power feed drum switch must be activated in the forward direction before the blade motor can be turned on.
- The Blade ON indicator light comes on whenever the debarker blade motor is on.
- **Non-Remote Sawmills:** The blade motor circuit breaker can be reset by pushing the boot-covered tab on the back of the control box.

- **Remote Sawmills:** The blade motor circuit breaker can be reset by pushing the boot-covered tab on the side of the remote power box.

4.3 Operation



DANGER! Make sure all guards and covers are in place and secured before operating the debarker option. Failure to do so may result in serious injury.

DANGER! Keep all persons out of the path of moving equipment when operating the debarker. Failure to do so will result in serious injury.

1. Remove the blade motor cover before operating the debarker.
2. Make sure the warning bell sounds when the debarker is turned on.



WARNING! Debarker is ON when warning bell sounds. DO NOT disconnect the warning bell. Doing so may result in serious injury.

3. Use the in/out switch on the control box to pivot the debarker all the way out.



4. Move the sawmill carriage forward and pivot the debarker in until the front fence engages with the end/side of the log.
5. Turn the debarker on/off switch to ON (1).



6. Proceed with cutting. The actuator will keep the debarker against the side of the log. Depending on log shape, you may have to pivot the debarker in and out for smooth cutting.



NOTE: The debarker can continuously remove up to approximately 1” of material from the log; no motor cool down time is required. Slower feed rates may be required for optimal debarker operation.

7. Once the carriage is past the end of the log, pivot the debarker away from the log. Return the carriage.



IMPORTANT! Should the carriage be returned before the debarker has been pivoted out of the way of the log, the debarker is designed to pivot upwards. If this happens, continue to **SLOWLY** return the carriage; or stop, pivot the debarker out and then return the carriage. **DO NOT** move the carriage forward while the debarker is contacting the log without the blade spinning.

8. When done sawing and ready to store or transport the sawmill, replace the debarker blade motor cover. Place the debarker in its travel position before towing the sawmill ([See Section 4.1](#)).

4.4 Maintenance

 **DANGER!** Before performing any service to this equipment, turn the key to the OFF (0) position and remove the key. Failure to do so will result in serious injury or death.

1. Lubricate the two or three pivot joints with a NLGI #2 grade lithium grease every 40 hours of operation (third fitting added to travel pin block 11/07).

See Figure 4-3.

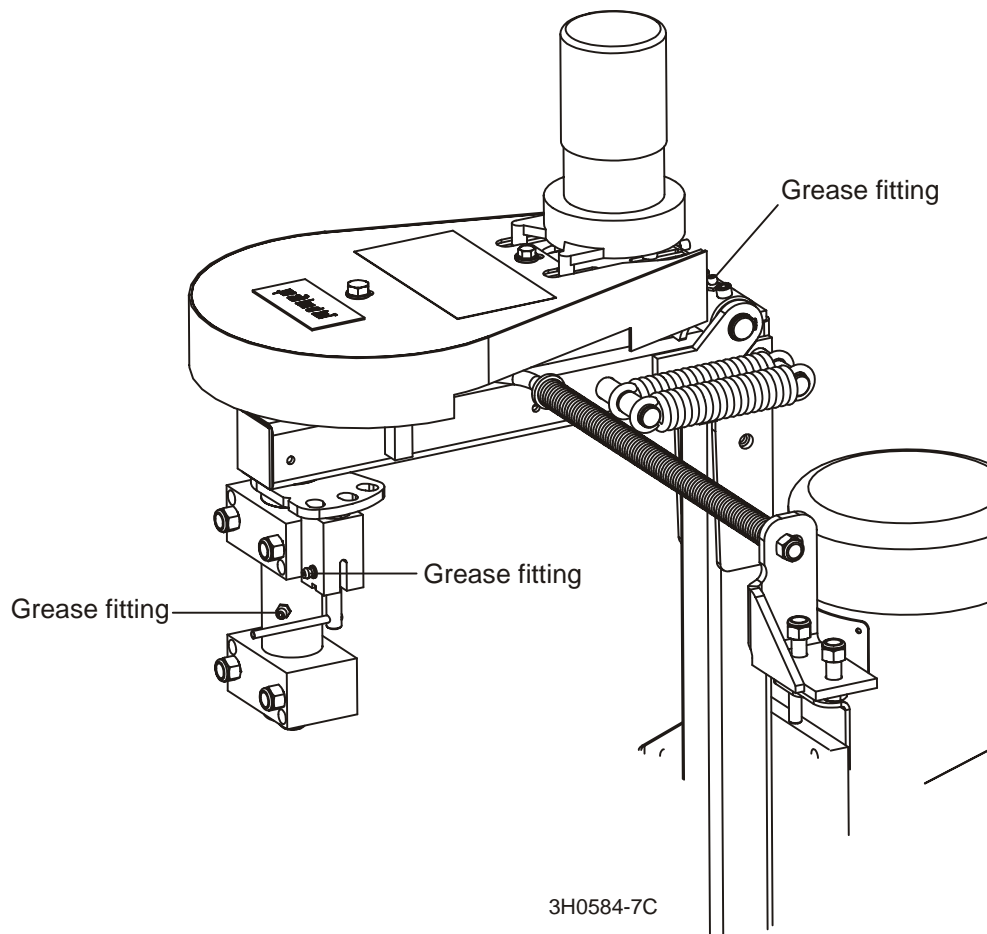

FIG. 4-3

2. Periodically check the flexible guard. Adjust the guard up or down so the bottom is even with the bottom of the debarker blade. Replace the guard as needed.

3. Periodically check the debarker blade. Align or replace as needed.



WARNING! Before replacing the debarker blade, move the sawmill blade guide arm in front of the sawmill blade to cover the blade teeth. Failure to do so may result in serious injury or death.

To replace the debarker blade, remove the lower blade guard plate. Place one wrench on the blade arbor, above the blade bearing. Place the other wrench on the lower nut and rotate clockwise (bolt has left-hand threads). Remove the nut. Remove the blade.

Install the new blade. Reinstall the lower nut and turn counterclockwise to tighten to 35 foot-pounds (± 5). Reinstall the blade guard plate.



CAUTION! Tighten the blade bolt manually. Using power-assisted tools may result in over-torquing and damage to the nut.

4. Periodically check belt for tension and wear. Adjust or replace as necessary. Apply a dry lubricant such as Teflon spray or silicon to the spring rod and spring every 40 hours of operation.

4.5 Troubleshooting



DANGER! Before performing any service to this equipment, turn the key to the OFF (0) position, remove the key, and disconnect the sawmill battery ground terminal. Failure to do so will result in serious injury or death.

PROBLEM	CAUSE	SOLUTION
50 amp circuit breaker tripping	Both intermittent duty spring and continuous duty spring are installed (Rev. A only)	Remove intermittent duty spring
	Only continuous duty spring is installed (Rev. A only)	Remove spring. Cut spring free length down from 14 1/2" to 12 1/2"
50 amp circuit breaker tripping	Wood or bark jammed in blade guard	Turn key to OFF position, remove key. Remove wood or bark from blade guard
	Pivot pin is binding.	Inspect for bind by moving debarker head to full in position. Turn key to OFF position, remove key. Pull arm to full out position by hand. If available, use a weight scale to pull arm to full out position. Should not have more than 12 pounds of resistance to pull out. Ensure pivot pin has been greased properly. Check pivot clamps for correct installation. Loosen pivot clamp bolts slightly, check for reduced binding
	Ring terminal of blue wire (Rev. A) or red wire (Rev. B+) touching debarker motor housing at motor	Move terminal away from motor housing. Reset circuit breaker and retest. See <i>Resetting the Circuit Breaker (Rev. A Only)</i>
Light comes on, but debarker motor and warning horn do not operate	Circuit breaker weak from repeated tripping.	Replace circuit breaker
	Circuit breaker tripped	Reset circuit breaker. See <i>Resetting the Circuit Breaker (Rev. A Only)</i>
Debarker shuts off, but the circuit breaker is not tripped.	Bad ignition wire connection	Check ignition wire connection outside and inside of debarker control box.
	Intermittent key switch	Replace key switch
	Other loose wiring connection	Check wiring connections inside control box.

Debarker will not shut off.	Solenoid is stuck closed.	Replace solenoid.
IN/OUT Motor does not move IN or OUT	Drive belt too loose	Tighten enough to allow movement. DO NOT OVER-TIGHTEN.
	Switch not working properly	Check wiring to switch for loose connections. If wiring looks OK, replace switch.

Resetting the Circuit Breaker (Rev. A Only)

To reset the circuit breaker on revision A debarkers, turn the key switch to the OFF position and remove the key. Remove the front control panel.

Be sure to reinstall the front panel and secure in place to ensure safe operation and to protect panel components.



DANGER! Never operate the Debarker without all covers and guards in place.

SECTION 5 ELECTRICAL INFORMATION

5.1 Electrical Symbol Diagram

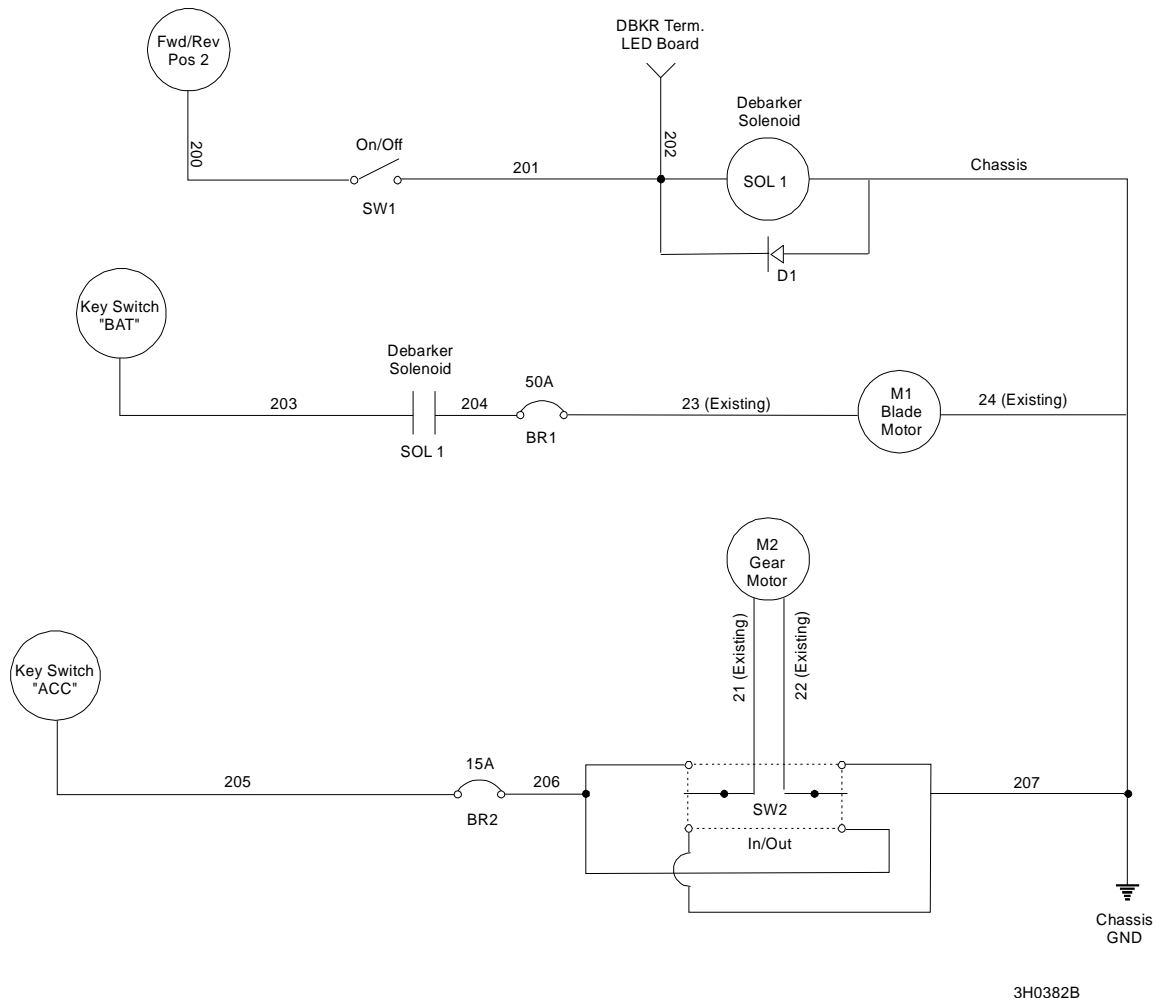

FIG. 5-1

5.2 Electrical Component List

ID	Manufacturer Part No.	Manufacturer	Wood-Mizer Part No.	Description
BR1	1648-009-050-006	Mechanical Products, Inc.	021256	Breaker, 50 Amp Manual Reset Panel Mount Circuit (Revision B+)
	CH-30407-50	Cole Hersee	E20432	Breaker, 50 Amp Manual Reset Circuit (Revision A Only)
BR2	CH30407-15	Cole Hersee	E20430	Breaker, 15 Amp
D1	N/A	N/A	015426	Diode Assembly, Solenoid Coil Chassis
H1	PS-521	Mallory	021137	Horn, Debarker ON Warning
M1	PR40009Q	0W0SS0	014359 ¹	Motor, 12 Volt
M2	N/A	Klauber Machine & Gear Co.	P09698-1	Motor, 53:1 Gear
SOL1	120-943	White Rodgers	016372 ²	Solenoid, 12V 100A Cont Duty GND Coil
SW1	4X846	Carling Switch	P03027	Switch, Toggle
SW2	34-591Q	Pollak	024200 ³	Switch, DPDT Toggle
	1121-0004	McGill	P10006 ³	Switch, DPDT Toggle

¹ Replaces 021220 motor originally supplied on Rev. A.

² Solenoid Kit 016372 replaces Solenoid P10449. Kit includes solenoid and replacement instructions.

³ Use P10006 Toggle Switch for Debarkers prior to Rev. D.00. Use 024200 toggle switch for Debarkers Rev. D.00 and later.

SECTION 6 DEBARKER PARTS

6.1 Mount/Lock Pin Assembly

Rev. D.03+

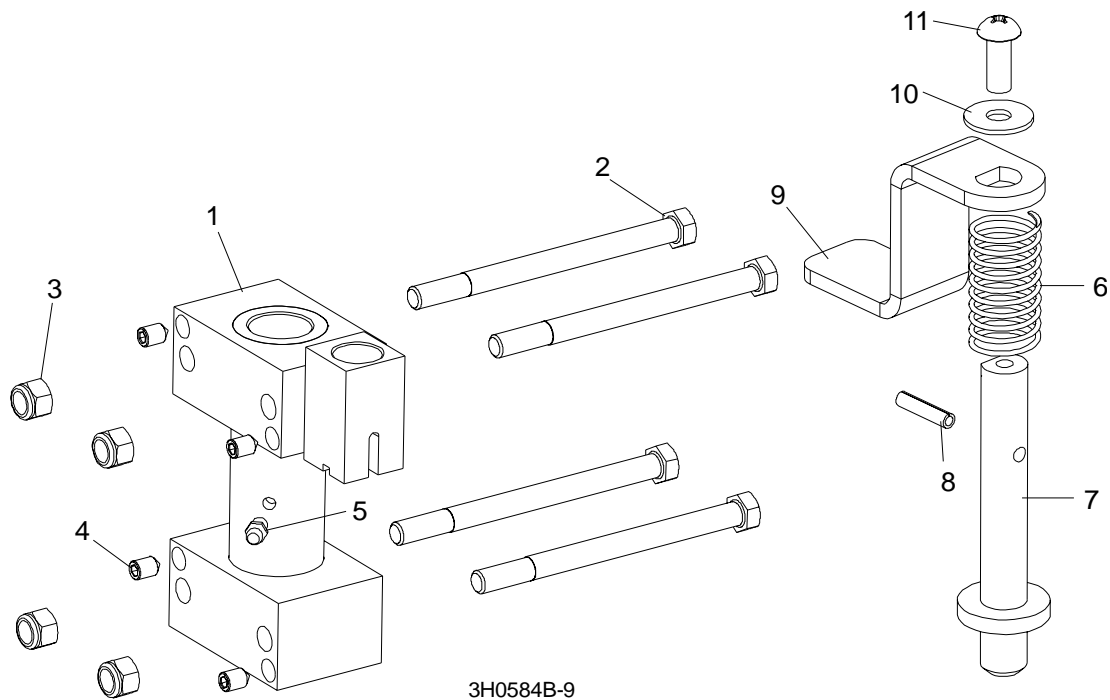

REF	DESCRIPTION (◆ Indicates Parts Available In Assemblies Only)	PART #	QTY.	
	PIVOT KIT, DEBARKER MOUNT	021284	1	
1	Mount Weldment, Debarker Frame Pivot	021282	1	◆
2	Bolt, 3/8-16 x 5" Hex Head	F05007-5	4	
3	Nut, 3/8-16 Hex Nylon Lock	F05010-10	4	
4	Screw, 5/16-24 x 1/2" Cone Point Socket Set	F05006-96	4	
5	Fitting, 1/4-28 Grease	P05060	1	
	Fitting, 3/16" x 3/16" Straight Grease	P04107 ¹	1	
	PIN ASSEMBLY, DEBARKER TRAVEL	021271	1	
6	Spring, .58" OD x 1 1/8"	021243	1	
7	Pin, Debarker Travel	021275	1	◆
8	Pin, 1/8" x 9/16" Roll	F05012-30	1	
9	Handle, Travel Pin	021274	1	
10	Washer, #8 SAE Flat	F05011-41	1	
11	Screw, #8-32 x 1/2" Cross Slotted Round Head	F05004-52	1	

¹ Grease fitting added to travel pin block 11/07.

6.2 Mount/Lock Pin Assembly

Rev. B.00 - D.02

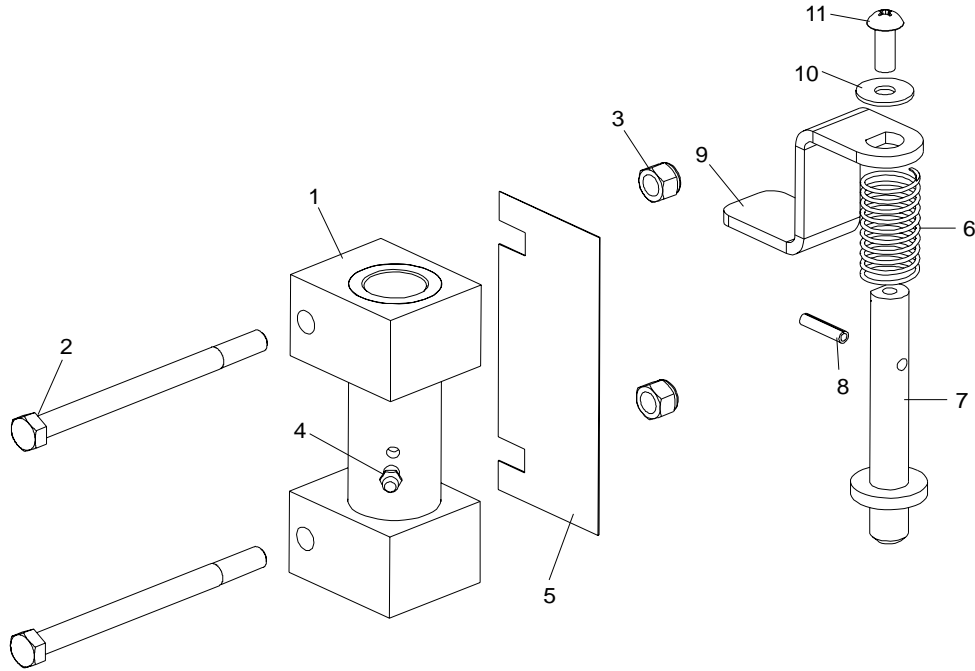

3H0576-2

REF	DESCRIPTION (◆ Indicates Parts Available In Assemblies Only)	PART #	QTY.	
	PIVOT KIT, DEBARKER MOUNT	021284 ¹	1	
1	Mount Weldment, Debarker Pivot	021282	1	◆
2	Bolt, 3/8-16 x 5" Hex Head	F05007-5 ²	4	
3	Nut, 3/8-16 Hex Nylon Lock	F05010-10	4	
4	Fitting, 1/4-28 Grease	P05060	1	
	Screw, 5/16-24 x 1/2" Cone Point Socket Set	F05006-96	4	
	Fitting, 3/16" x 1/16" Straight Grease	P04107	1	
	Instruction Sheet, Debarker Pivot Mount	021284-676	1	
5	PAD, DEBARKER MOUNT ANTI-PIVOT	016048 ³	1	
	PIN ASSEMBLY, DEBARKER TRAVEL	021271	1	
6	Spring, .58" OD x 1 1/8"	021243	1	
7	Pin, Debarker Travel	021275	1	◆
8	Pin, 1/8" x 9/16" Roll	F05012-30	1	
9	Handle, Travel Pin	021274	1	
10	Washer, #8 SAE Flat	F05011-41	1	
11	Screw, #8-32 x 1/2" Cross Slotted Round Head	F05004-52	1	

¹ Retrofit kit 021284 replaces two single blocks 021260 and pivot 021254 originally supplied until 9/96 with single piece weldment. Mount kit upgraded with four-bolt mount 4/98. [See Section 6.1](#). Two additional holes required to use four-bolt mount. Grease fitting added to travel pin block 11/07.

5

Debarker Parts

Mount/Lock Pin Assembly

- ² Replaces 3/8-16 x 4" socket head cap screw (F05005-103) originally supplied until 9/96. Mount kit upgraded with four-bolt mount 4/98. [See Section 6.1.](#)
- ³ Mount pad 016048 added to prevent loss of debarker alignment caused by mount pivoting during operation (Rev. D.02). Mount may also be upgraded to four-bolt design ([See Section 6.1](#)). Debarker revision level rolled from B.01 to D.02 to maintain consistency with other Debarker assemblies.

6.3 Mount/Lock Pin Assembly

Rev. A.00

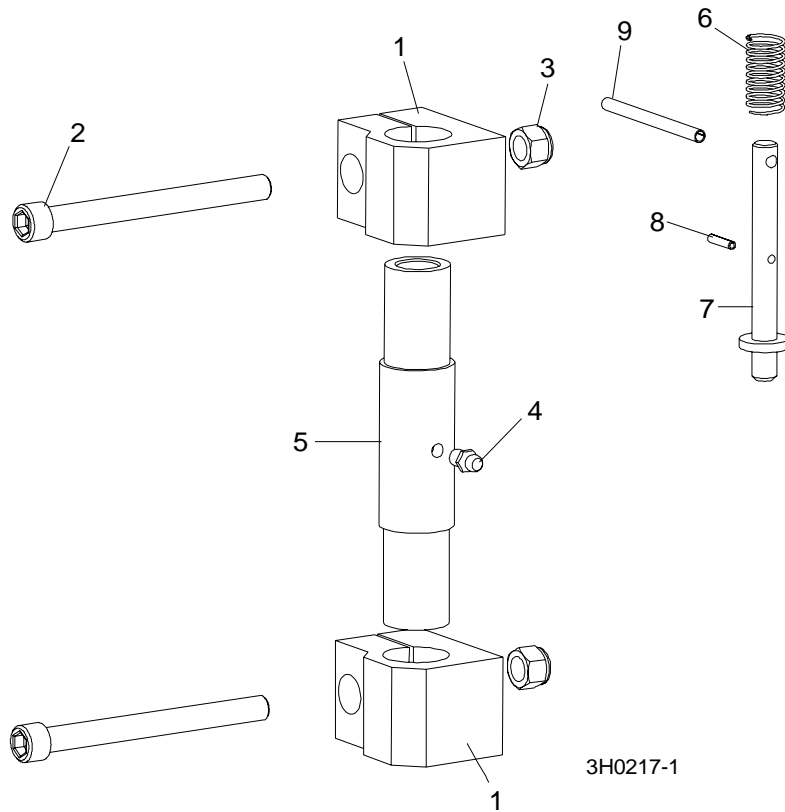

REF	DESCRIPTION (◆ Indicates Parts Available In Assemblies Only)	PART #	QTY.	
	MOUNT ASSEMBLY, DEBARKER PIVOT	021140	1	
1	Block, Pivot Tube Mount	021142	2	
2	Screw, 3/8-16 x 4" Socket Head	F05005-103	2	
3	Nut, 3/8-16 Hex Nylon Lock	F05010-10	2	
4	Fitting, 1/4-28 Grease	P05060	1	
5	Tube, Debarker Pivot	021141	1	
	PIN ASSEMBLY, DEBARKER TRAVEL	021242	1	
6	Spring, .58" OD x 1 1/8"	021243	1	
7	Pin, Debarker Travel	021245	1	◆
8	Pin, 1/8" x 9/16" Roll	F05012-30	1	
9	PIN, 3/16" X 2 1/2" ROLL	F05012-27	1	

6.4 Frame Assembly

Rev. B.00+

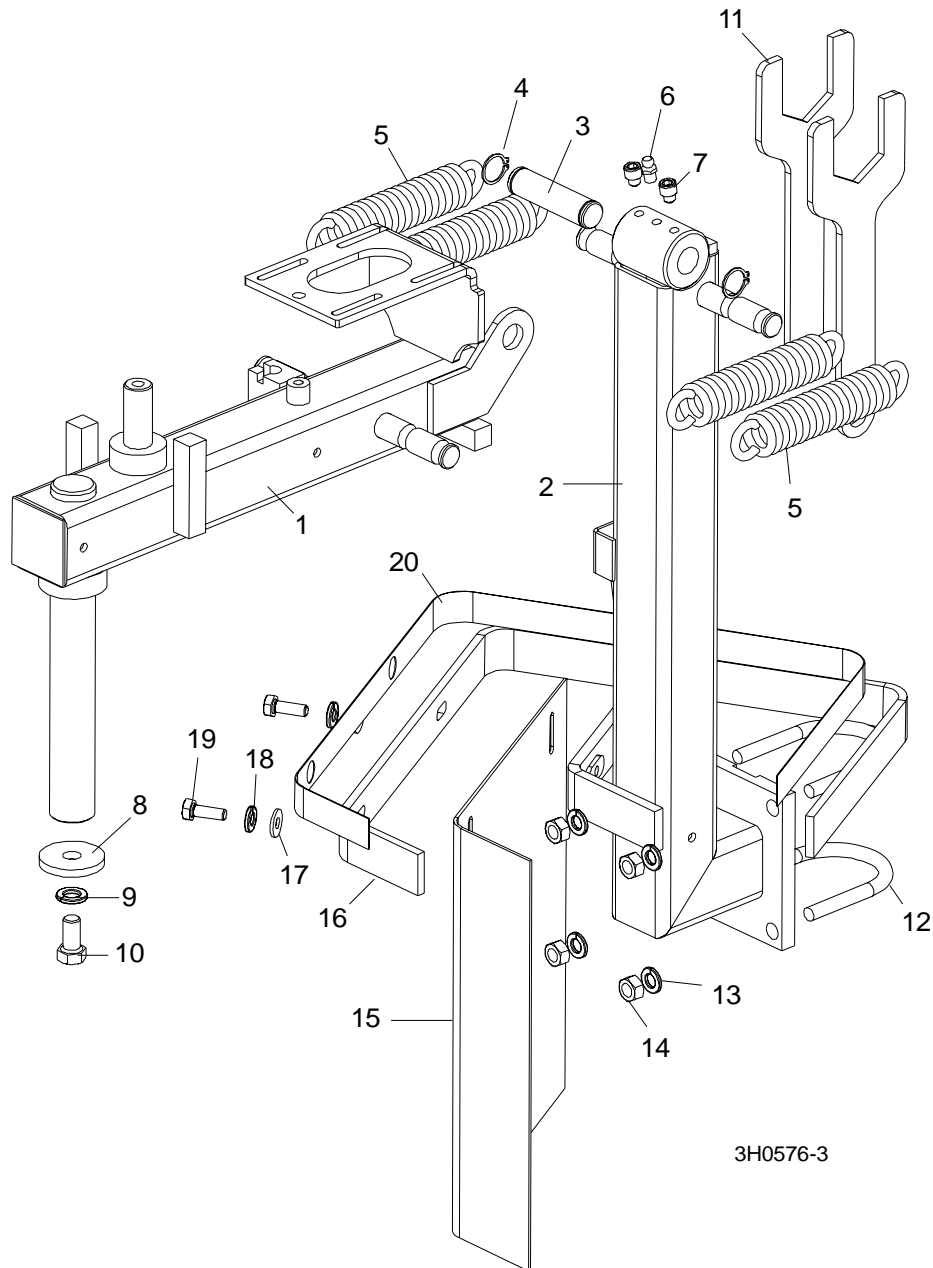

REF	DESCRIPTION (◆ Indicates Parts Available In Assemblies Only)	PART #	QTY.
1	ARM WELDMENT, UPPER FRAME	021270	1
2	FRAME WELDMENT, DEBARKER	021199	1
3	PIN, DEBARKER FRAME PIVOT	021196	1
4	RING, 5/8" OUTSIDE RETAINING	F04254-2	1

5	SPRING, DEBARKER	021185	4	
6	FITTING, 1/4-28 GREASE	P05060	2	
7	SCREW, 1/4-28 X 1/4" SOCKET HEAD	F05005-106	2	
8	WASHER, .40 X 1.44 X .18	021276	1	
9	WASHER, 3/8" SPLIT LOCK	F05011-4	1	
10	BOLT, 3/8-16 X 3/4" HEX HEAD GRADE 2	F05007-27	1	
11	WRENCH, DEBARKER BLADE	021146	2	
12	U-BOLT, DEBARKER	021176	2	
13	WASHER, 5/16" SPLIT LOCK	F05011-13	4	
14	NUT, 5/16-18 HEX	F05010-17	4	
15	GUARD, FLEXIBLE	021232	1	
16	BRACKET, GUARD	021231	1	
17	WASHER, 1/4" SAE FLAT	F05011-11	2	
18	WASHER, 1/4" SPLIT LOCK	F05011-14	2	
19	BOLT, 1/4-20 X 1" HEX HEAD GRADE 2	F05005-38	2	
20	DECAL, DEBARKER GUARD	015849	1	

6.5 Frame Assembly

Rev. A.00

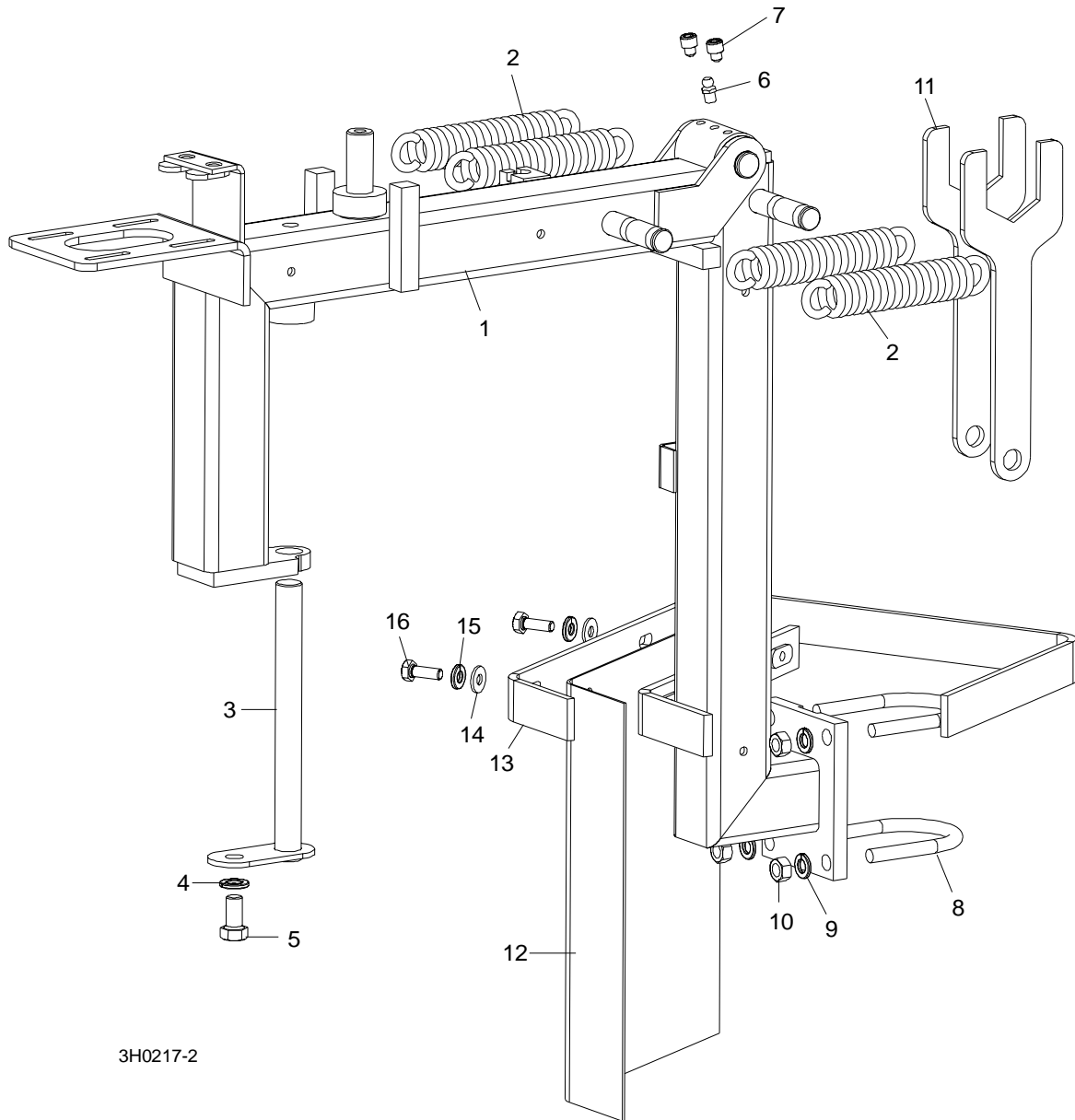

3H0217-2

REF	DESCRIPTION (◆ Indicates Parts Available In Assemblies Only)	PART #	QTY.
1	FRAME WELDMENT, DEBARKER	021198	1
2	SPRING, DEBARKER	021185	4
3	PIN WELDMENT, DEBARKER PIVOT	021175	1
4	WASHER, 3/8" SPLIT LOCK	F05011-4	1
5	BOLT, 3/8-16 X 3/4" HEX HEAD GRADE 2	F05007-27	1
6	FITTING, 1/4-28 GREASE	P05060	1

7	SCREW, 1/4-28 X 1/4" SOCKET HEAD	F05005-106	2	
8	U-BOLT, DEBARKER	021176	2	
9	WASHER, 5/16" SPLIT LOCK	F05011-13	4	
10	NUT, 5/16-18 HEX	F05010-17	6	
11	WRENCH, DEBARKER BLADE	021146	2	
12	GUARD, FLEXIBLE	021232	1	
13	BRACKET, GUARD	021231	1	
	DECAL, DEBARKER GUARD	015849 ¹	1	
14	WASHER, 1/4" SAE FLAT	F05011-11	2	
15	WASHER, 1/4" SPLIT LOCK	F05011-14	2	
16	BOLT, 1/4-20 X 3/4" HEX HEAD FULL THREAD	F05005-1	2	

¹ Replaces 021250 originally supplied until Rev. D.01.

6.6 In/Out Motor Drive Assembly

Rev. B.00+

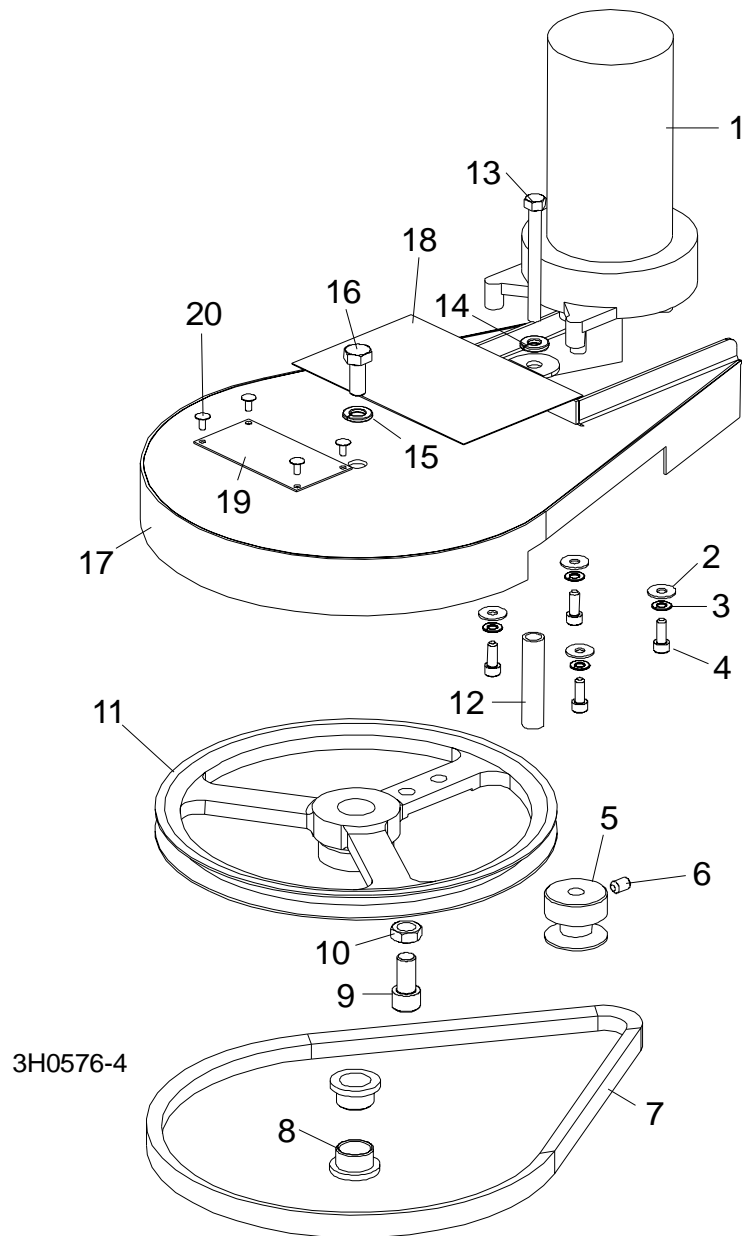

REF	DESCRIPTION (◆ Indicates Parts Available In Assemblies Only)	PART #	QTY.	
1	MOTOR, 53:1 GEAR	P09698-1	1	
	Housing, Klauber Motor End	P12756	1	
	Gear Kit, Klauber Gear Motor Replacement	P12569	1	
	Brush Kit, Gear Motor Replacement	P12800	1	
	Shaft Kit, Klauber Gear Motor Replacement	009695	1	

2	WASHER, #10-24 SAE FLAT	F05011-18	4	
3	WASHER, #10 SPLIT LOCK	F05011-20	4	
4	SCREW, #10-32 X 1/2" SOCKET HEAD	F05004-79	4	
5	PULLEY, GEAR MOTOR	016181 ¹	1	
6	SCREW, 1/4-20 X 3/8" CUP POINT SOCKET SET	F05005-47 ¹	1	
7	BELT, 4L300 V	021183	1	
	PULLEY ASSEMBLY, DRIVEN	021273	1	
8	Bushing, Flanged Bronze	021203	2	
9	Screw, 3/8-16 x 3/4" Socket Head	F05005-104	1	
10	Nut, 3/8-16 Hex Jam	F05010-29	1	
11	Pulley, Modified Driven	021212	1	
12	SPACER, 1 15/16" MOTOR PULLEY GUARD	014424 ²	1	
13	BOLT, 1/4-20 X 2 1/2" HEX HEAD	F05005-7	1	
14	WASHER, 1/4" SPLIT LOCK	F05011-14	1	
15	WASHER, 5/16" SPLIT LOCK	F05011-13	1	
16	BOLT, 5/16-18 X 3/4" HEX HEAD GRADE 2	F05006-5	1	
17	COVER WELDMENT, DEBARKER PULLEY	021269	1	
18	DECAL, DEBARKER DANGER	021172	1	
19	PLATE, DEBARKER REVISION	005801-293 ³	1	◆
	PLATE, INSTALLED DEBARKER REVISION	005801-283 ³	1	◆
20	RIVET, 1/8" X 1/8" ALUMINUM POP	F04203-8	4	

¹ Gear Motor Pulley 016181 and Roll Pin F05012-34 replace Gear Motor Pulley 021190 with 1/4-20 x 3/8" Cup Point Set Screw F05005-47 originally supplied.

² Replaces 021259 spacer originally supplied until 9/96.

³ Replaces 021240 revision decal (Rev. C.00).

6.7 In/Out Motor Drive Assembly

Rev. A.00

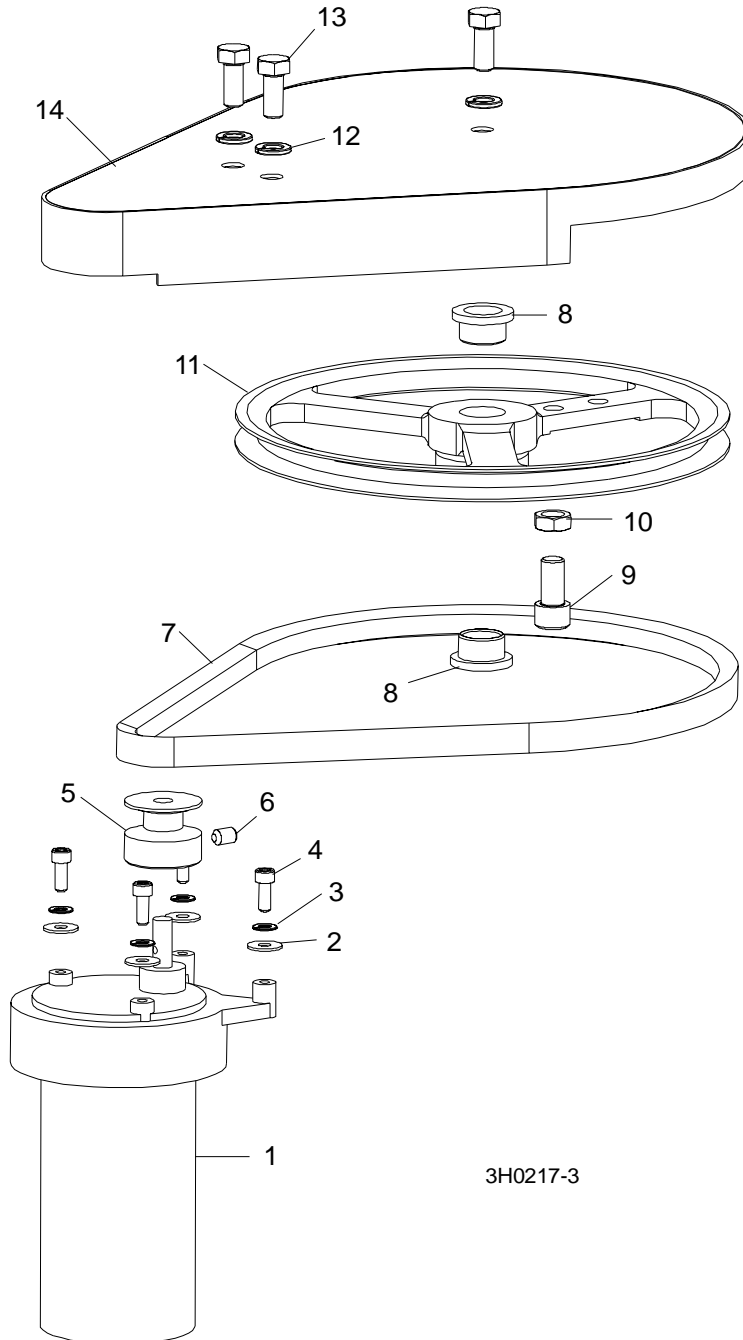

REF	DESCRIPTION (◆ Indicates Parts Available In Assemblies Only)	PART #	QTY.	
1	MOTOR, 53:1 GEAR	P09698-1	1	
	Housing, Klauber Motor End	P12756	1	

	Gear Kit, Klauber Gear Motor Replacement	P12569	1	
	Brush Kit, Gear Motor Replacement	P12800	1	
	Shaft Kit, Klauber Gear Motor Replacement	009695	1	
2	WASHER, #10-24 SAE FLAT	F05011-18	4	
3	WASHER, #10 SPLIT LOCK	F05011-20	4	
4	SCREW, #10-32 X 1/2" SOCKET HEAD	F05004-79	4	
5	PULLEY, GEAR MOTOR	016181 ¹	1	
6	SCREW, 1/4-20 X 3/8" CUP POINT SOCKET SET	F05005-47 ¹	1	
7	BELT, 4L300 V	021183	1	
	PULLEY ASSEMBLY, DRIVEN	021273	1	
8	Bushing, Flanged Bronze	021203	2	
9	Screw, 3/8-16 x 3/4" Socket Head	F05005-104	1	
10	Nut, 3/8-16 Hex Jam	F05010-29	1	
11	Pulley, Modified Driven	021212	1	
12	WASHER, 5/16" SPLIT LOCK	F05011-13	3	
13	BOLT, 5/16-18 X 3/4" HEX HEAD GRADE 2	F05006-5	3	
14	COVER WELDMENT, DEBARKER PULLEY	021189	1	

¹ Gear Motor Pulley 016181 and Roll Pin F05012-34 replace Gear Motor Pulley 021190 with 1/4-20 x 3/8" Cup Point Set Screw F05005-47 originally supplied.

6.8 Blade Motor & Horn Assembly

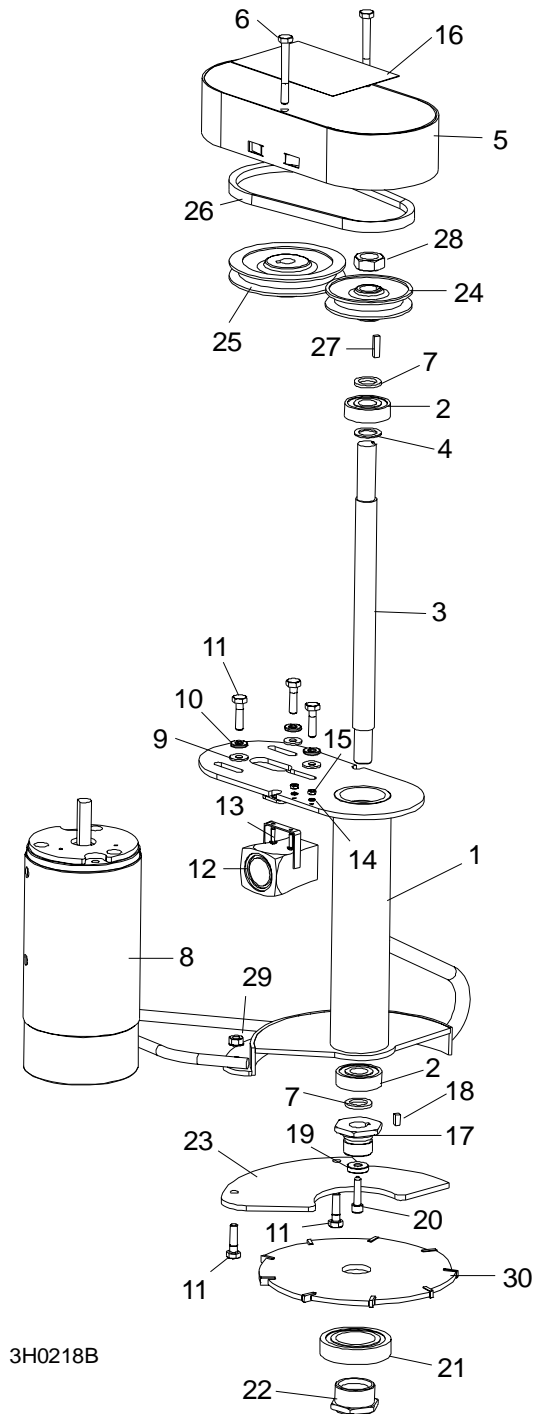

REF	DESCRIPTION (◆ Indicates Parts Available In Assemblies Only)	PART #	QTY.
	HEAD ASSEMBLY, DEBARKER CUTTING	021204 ¹	1

1	Head Weldment, Debarker Cutting	021162	1	
	Shaft Assembly, Arbor Bearing Replacement	021297	1	
2	Bearing, 5/8" x 1.5748" x .4724"	P06030-1	2	
3	Shaft, Debarker Arbor	021202	1	◆
4	Shim, .025 Arbor	015742	1	◆
5	Cover Weldment, Debarker Motor Pulley	021152	1	
6	Bolt, 1/4-20 x 2 1/4" Hex Head Grade 2	F05005-32	2	
7	Washer, 5/8" x 15/16" x .094" Nylon	F05011-19	2	
8	Motor, Debarker	006747 ²	1	
	Brush Kit, 12V Motor (2008)	061794 ²	1	
	Brush Kit, 12V Motor (2007)	006619 ²	1	
	Brush Kit, 12V Motor	A09086 ²	1	
	Brush Holder, Motor	034000 ²	1	◆
9	Washer, 1/4" SAE Flat	F05011-11	3	
10	Washer, 1/4" Split Lock	F05011-14	3	
11	Bolt, 1/4-20 x 1" Hex Head Grade 2	F05005-38	5	
12	Horn, Debarker Warning	021137	1	
13	Screw, #4-40 x 1/2" Slotted	F05004-14	2	
14	Washer, #4 Split Lock	F05011-21	2	
15	Nut, #4-40 Hex	F05010-43	2	
16	Decal, Debarker Danger	021172	1	
17	Hub, Debarker Cutter	S13352	1	
18	Key, 3/16" Square	021205	1	
19	Spacer, Hub Retainer	021206	1	
20	Screw, 1/4-28 x 1" Socket Head	F05005-102	1	
	Nut Assembly, Debarker Cutter Bearing	021237 ³	1	
21	Bearing, 5/8" Debarker Cutter	021261	1	◆
22	Nut, Debarker Cutter (Left-Handed Thread)	S13349	1	◆
23	Plate, Debarker Head Bottom	021161	1	
24	Pulley, Debarker Arbor	021192	1	
25	Pulley, Debarker Motor	021193	1	
26	Belt, 3L180 Debarker Drive	021182 ⁴	1	
	Screw, 1/4-20 x 3/8" SHCP Set	F05005-47	1	
27	Key, 3/16" x 3/4"	S03060	1	
28	Nut, 5/8-18 Hex Jam	F05010-11	1	
29	Nut, 1/4-20 Self-Locking	F05010-9	2	
30	Blade, Debarker Cutting	021236	1	

¹ Support Plate Retrofit available for Rev. A Debarkers. [See Section 6.10.](#)

² Motor 006747 replaces 014359 originally supplied prior to 11/08. Use brush kit 061794 for new motor. 014359 motor changed by vendor 7/07. Use brush kit A09086 for original motor supplied prior to 7/07. Use brush kit 006619 for newer 014359 motor (identified by red & black motor terminal spacers). Brush Holder 034000 applies only to old motor and is no longer available (vendor discontinued 3/09).

³ Nylon bearing directly replaces 021213 bearing originally supplied on Rev. A.



Debarker Parts

Blade Motor & Horn Assembly

⁴ 3L180 belt (021182) used until 8/96 and replaced with 4L190 belt (021281). Returned to using 3L180 belt (021182) after 10/96 to prevent belt from interfering with cover bolts.

6.9 Debarker Control Assembly

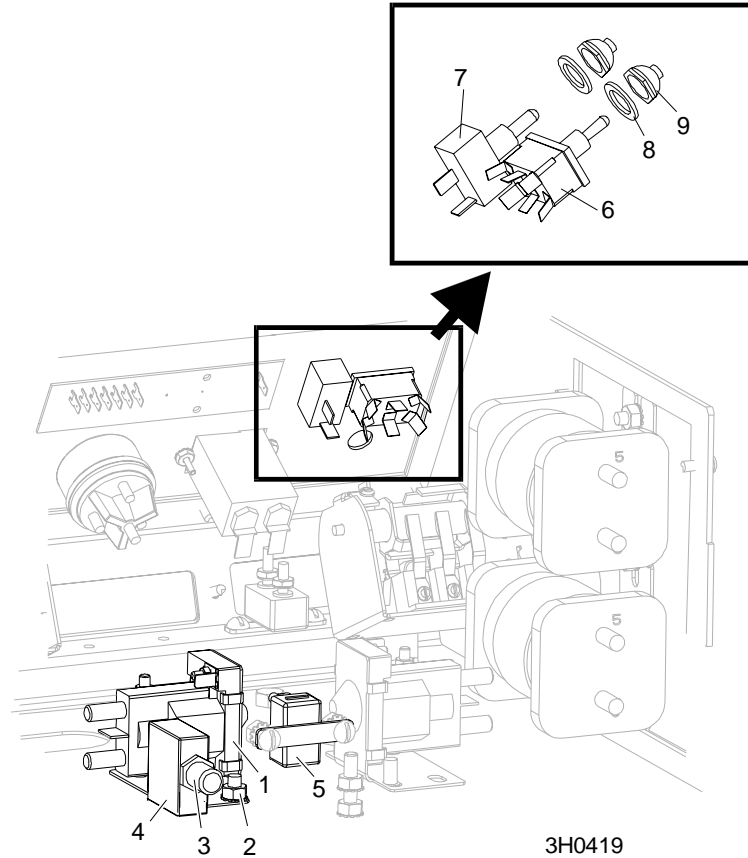

3H0419

REF	DESCRIPTION (◆ Indicates Parts Available In Assemblies Only)	PART #	QTY.	
	CONTROL ASSEMBLY, DEBARKER	024220 ¹	1	
1	Solenoid Kit, Accessory	016372 ²	1	
	Solenoid, 100A 12V Cont. Duty GND	P10449	1	◆
	Diode Assembly, Solenoid Coil Chassis GND	015426	1	
2	Nut, 1/4-20 Self Locking	F05010-9	2	
3	Boot, Circuit Breaker	021253	1	
4	Breaker, 50Amp Manual Reset Panel Mount	021256	1	
5	Breaker, 15 Amp Manual Reset	E20430	1	
6	Switch, DPDT Toggle Return Center Screw Terminal	024200 ¹	1	
	Switch, DPDT Toggle	P10006 ¹	1	
7	Switch, SPST Toggle Quick Connect	P03027	1	
8	Washer, 1/2 x 3/4 x 1/16" Nylon	P05251-1	2	
9	Boot, Toggle Switch	P02575	2	

¹ Use P10006 Toggle Switch for Debarkers prior to Rev. D.00. Use 024200 toggle switch for Debarkers Rev. D.00 and later. Control Assembly 024220 with new toggle switch replaces 021294 originally supplied prior to Rev. D.00. Sawmills prior to the following revisions will require modification with spade terminals to use the new control/toggle switch: LT30 and LT30 Super Rev. F9.00, LT40 and LT40 Super Rev. G1.00, LT30HD/40HD and LT30HD/40HD Super Rev. G3.00.



Debarker Parts

Debarker Control Assembly

² Solenoid Kit 016372 replaces Solenoid P10449. Kit includes solenoid and replacement instructions. Diode Wire Assembly 015426 added to Solenoid Kit 016372 (8/04).

6.10 Debarker Support Plate Retrofit

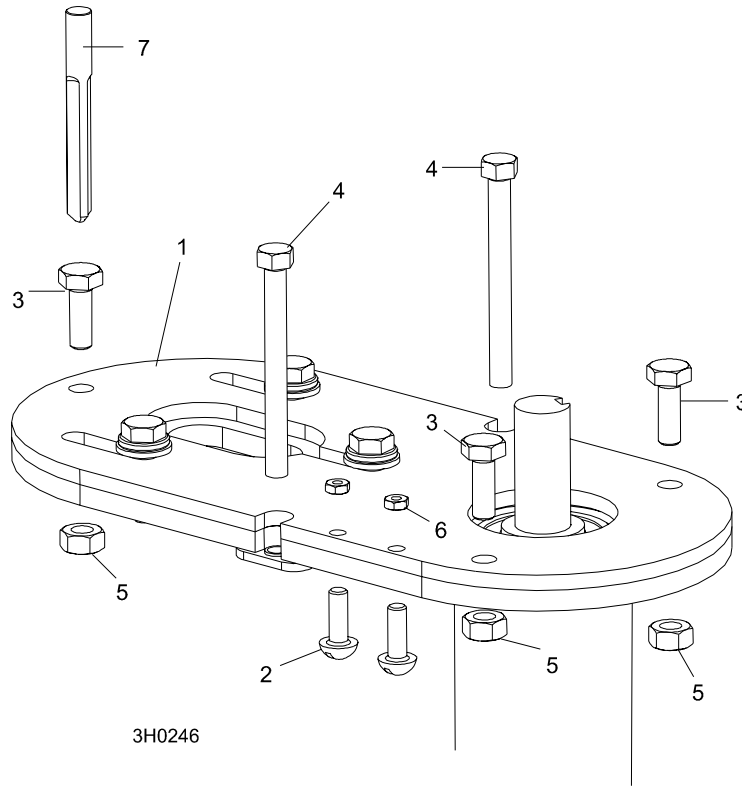

REF	DESCRIPTION (◆ Indicates Parts Available In Assemblies Only)	PART #	QTY.
	PLATE KIT, DEBARKER SUPPORT	021280 ¹	1
1	Plate, Debarker Support	021279	1
2	Screw, 4-40x5/8 Slotted Round	F05004-49	2
3	Bolt, 1.4-20 x 3/4" Hex Head FT	F05005-1	3
4	Bolt, 1/4-20 x 2 1/2" Hex Head	F05005-7	2
5	Nut, 1/4-20 Hex Lock	F05010-21	3
6	Nut, #4-40 Hex	F05010-43	2
7	Bit, 9/32" Drill	021251	1
	Instruction Sheet, Debarker Support	021280-414	1

¹ Support Plate Retrofit available for Rev. A Debarkers to prevent head plate from bending during heavy usage.

6.11 Spring Rod Assembly

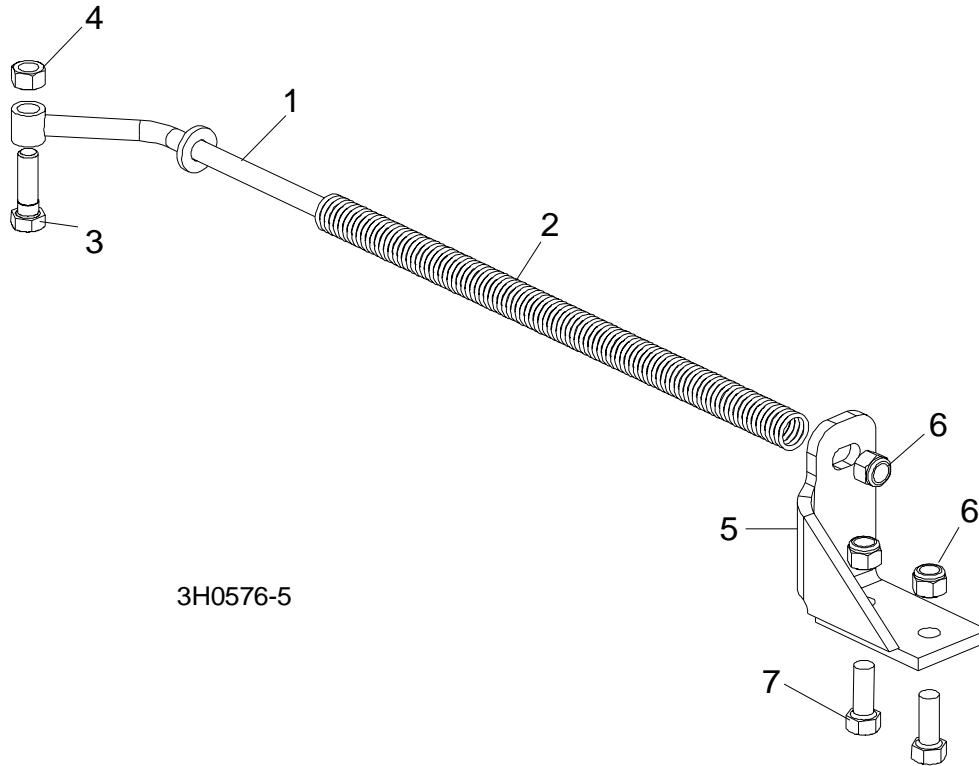

REF	DESCRIPTION (◆ Indicates Parts Available In Assemblies Only)	PART #	QTY.
	ROD ASSEMBLY, SPRING	021226	1
1	Rod Weldment, Spring Arm	021179	1
2	Spring, .72" x 12 1/2" x .080" Compression	021186 ¹	1
3	Bolt, 3/8-16 x 1 1/4" Hex Head Grade 2	F05007-2	1
4	Nut, 3/8-16 Hex Lock	F05010-25	1
5	Bracket, Spring Arm Mount	021180 ²	1
6	Nut, 3/8-16 Hex Nylon Lock	F05010-10	3
7	Bolt, 3/8-16 x 1" Hex Head	F05007-7	2

¹ 12 1/2" spring replaces 14 1/2" spring originally supplied on Rev. A Debarkers.

² Spring arm bracket redesigned with gusset 4/98. Will replace bracket originally supplied.

INDEX

A

alignment 2-26

E

electrical information 4-1
 component list 4-2
 symbol diagram (non-remote) 4-1

I

installation 2-1
 control components (standard) 2-19
 debarker 2-3
 frame mounting holes 2-2
 lower harness 2-8

M

maintenance 3-6

O

operation 3-4
 control overview 3-2
 locking pin 3-1

R

replacement parts
 blade motor & horn 5-13
 control 5-16
 frame 5-5
 in/out motor 5-9, 5-11
 mount/lock pin 5-1, 5-2, 5-4
 spring arm 5-19
 support plate retrofit 5-18

S

safety 1-1
 installation & maintenance 1-1
 operation & towing 1-2

T

troubleshooting 3-8
