

# Debarker Option

## Safety, Installation, Operation, Maintenance & Parts Manual

---

**MKIII for LT60/70 AC rev. A.00 - A.04  
(Except LT70 Super Sawmills\*)**

**\*See Operator's and Parts Manuals for Debarker Information**

---



**Safety is our #1 concern!** Read and understand all safety information and instructions before operating, setting up or maintaining this machine.

*January 2016*

*Form #2090*

**California**  
Proposition 65 Warning



**WARNING:** Breathing gas/diesel engine exhaust exposes you to chemicals known to the State of California to cause cancer and birth defects or other reproductive harm.

- Always start and operate the engine in a well-ventilated area.
- If in an enclosed area, vent the exhaust to the outside.
- Do not modify or tamper with the exhaust system.
- Do not idle the engine except as necessary.

For more information go to **[www.P65warnings.ca.gov](http://www.P65warnings.ca.gov)**.



**WARNING:** Drilling, sawing, sanding or machining wood products can expose you to wood dust, a substance known to the State of California to cause cancer. Avoid inhaling wood dust or use a dust mask or other safeguards for personal protection.

For more information go to **[www.P65Warnings.ca.gov/wood](http://www.P65Warnings.ca.gov/wood)**.

**©2019**

Printed in the United States of America, all rights reserved. No part of this manual may be reproduced in any form by any photographic, electronic, mechanical or other means or used in any information storage and retrieval system without written permission from

**Wood-Mizer**  
8180 West 10th Street  
Indianapolis, Indiana 46214

# Table of Contents

# Section-Page

<b>SECTION 1</b>	<b>SAFETY</b>	<b>1-1</b>
1.1	Installation and Maintenance.....	1-1
1.2	Operation and Towing.....	1-2
<b>SECTION 2</b>	<b>DEBARKER INSTALLATION</b>	<b>2-1</b>
2.1	Debarker Installation.....	2-1
2.2	Harness Installation.....	2-5
2.3	Control Component Installation.....	2-9
<b>SECTION 3</b>	<b>ALIGNMENT</b>	<b>3-1</b>
<b>SECTION 4</b>	<b>OPERATION AND MAINTENANCE</b>	<b>4-1</b>
4.1	Travel Lock Pin (Rev. A.04+).....	4-1
4.2	Travel Lock Pin Operation (Prior to Rev. A.04).....	4-1
4.3	Control Overview.....	4-3
4.4	Operation.....	4-4
4.5	Maintenance.....	4-6
4.6	Troubleshooting.....	4-8
<b>SECTION 5</b>	<b>ELECTRICAL INFORMATION</b>	<b>5-1</b>
5.1	Electrical Symbol Diagram (Non-Remote).....	5-1
	<i>Low Voltage</i> .....	5-1
	<i>High Voltage</i> .....	5-2
5.2	Electrical Symbol Diagram (Remote).....	5-3
	<i>Low Voltage</i> .....	5-3
	<i>High Voltage</i> .....	5-4
5.3	Electrical Component List.....	5-5
5.4	Electrical Wiring Diagram (non-Remote Sawmills).....	5-6
	<i>Low/High Voltage</i> .....	5-6
5.5	Electrical Wiring Diagram (Remote Sawmills).....	5-7
	<i>Low/High Voltage</i> .....	5-7
5.6	Electrical Wiring Diagram (AC Wireless Sawmills).....	5-9
	<i>Low/High Voltage</i> .....	5-9
<b>SECTION 6</b>	<b>DEBARKER PARTS</b>	<b>6-1</b>
6.1	Mechanical Assembly (AC).....	6-2
6.2	Frame Assembly (AC).....	6-3
6.3	In/Out Motor Drive Assembly.....	6-5
6.4	Blade Motor Assembly (AC).....	6-7
6.5	Blade Housing Assembly.....	6-8
6.6	Debarker Control Assembly.....	6-9

## INDEX

I

## SECTION 1 SAFETY



This symbol calls your attention to instructions concerning your personal safety. Be sure to observe and follow these instructions. This symbol accompanies a signal word. The word **DANGER** indicates an imminently hazardous situation which, if not avoided, will result in death or serious injury. **WARNING** suggests a potentially hazardous situation which, if not avoided, could result in death or serious injury. **CAUTION** refers to potentially hazardous situations which, if not avoided, may result in minor or moderate injury to persons or equipment. Read all safety instructions before operating this equipment and observe all safety warnings!

### 1.1 Installation and Maintenance



**DANGER!** On electric mills, hazardous voltage inside the disconnect box, starter box, and at the electric motor can cause shock, burns, or death. Disconnect and lock out power supply before performing debarker installation! Follow all applicable electrical codes.

**DANGER!** Make sure all electrical installation, service and/or maintenance work is performed by a qualified electrician and is in accordance with applicable electrical codes. Failure to do so will result in serious injury or death.

**DANGER!** Before performing any service to this equipment, turn the key to the OFF position, remove the key, and disconnect the sawmill battery ground terminal. Failure to do so will result in serious injury or death.



**WARNING!** Before replacing the debarker blade, move the sawmill blade guide arm in front of the sawmill blade to cover the blade teeth. Failure to do so may result in serious injury or death.

## 1.2 Operation and Towing



**DANGER!** Make sure all guards and covers are in place and secured before operating the debarker option. Failure to do so may result in serious injury.

**DANGER!** Keep all persons out of the path of moving equipment when operating the debarker. Failure to do so will result in serious injury.

**DANGER!** Always remove the key from the control panel before preparing the debarker for towing. Failure to do so may result in serious injury.



**WARNING!** Debarker is ON when warning light is on. DO NOT disconnect the warning light. Doing so may result in serious injury.

**WARNING!** If the debarker continues to run with the key switch in the OFF position, remove the negative battery terminal from the battery post.

DO NOT continue to operate the mill if the main key switch does not control debarker operation. Doing so could result in serious injury. Call Wood-Mizer customer service for more information.

## SECTION 2 DEBARKER INSTALLATION



**DANGER!** On electric mills, hazardous voltage inside the disconnect box, starter box, and at the electric motor can cause shock, burns, or death. Disconnect and lock out power supply before performing debarker installation! Follow all applicable electrical codes.

**DANGER!** Before performing any service to this equipment, turn the key to the OFF (0) position, remove the key, and disconnect the sawmill battery ground terminal. Failure to do so will result in serious injury or death.



**CAUTION!** Due to various design changes and past retrofits and options, you should very carefully look your mill over to determine Debarker compatibility before beginning Debarker installation.

### 2.1 Debarker Installation



**DANGER!** Always disengage the blade and shut off the sawmill engine before installing the debarker. Failure to do so will result in serious injury.

**IMPORTANT!** Sawmills are equipped with pre-drilled Debarker mounting holes. **Verify hole locations before beginning Debarker installation. Proper hole location is imperative for safe and effective Debarker operation.**

**See Figure 2-1.** The debarker wiring is pre-routed and secured at the debarker mounting location with a guard. Remove the guard and route the wiring through the grommet in the saw head. Note the location of the two debarker mounting holes.

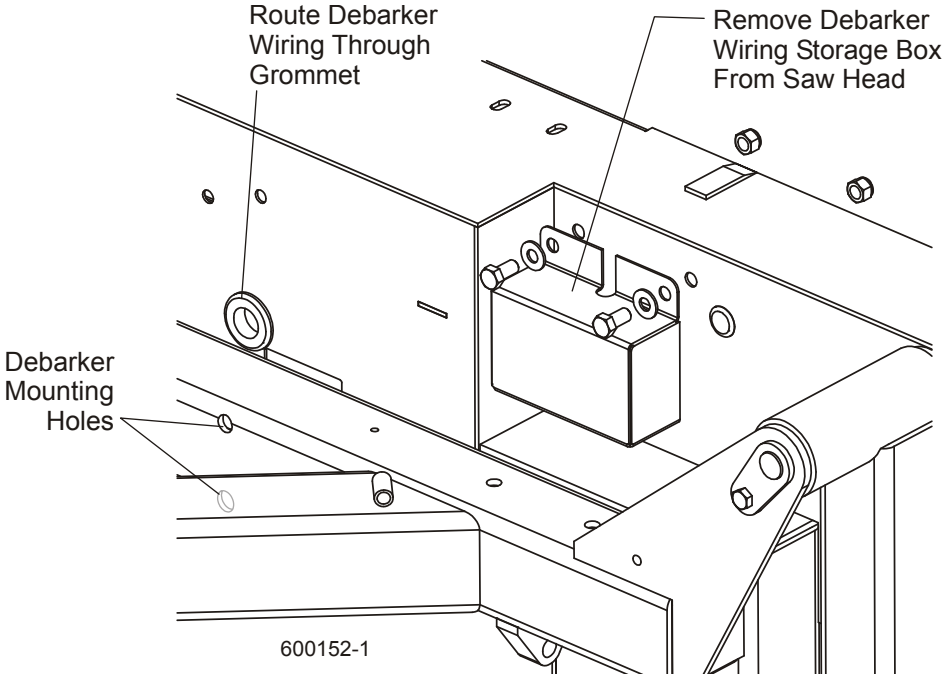
**FIG. 2-1**

1. Assemble the debarker to the sawmill saw head. Align the mounting block holes and the two debarker mounting holes in the saw head. Use the provided 1/2-13 x 4" hex head bolts and 1/2" split lock washers to secure in place. Make sure the debarker is square to the saw head before tightening.
2. Assemble the debarker cutting head to the mount plate on the frame.

Use the four provided 5/16-18 x 3/4" bolts and 5/16" split lock washers to mount the cutting head to the debarker frame. Use the lower set of four holes in the head mounting plate. The upper set of holes are provided in the event the cutting head needs to be adjusted further down than the slotted motor mount holes will allow.

**See Figure 2-2.**

## 2

### Debarker Installation

#### Debarker Installation

---

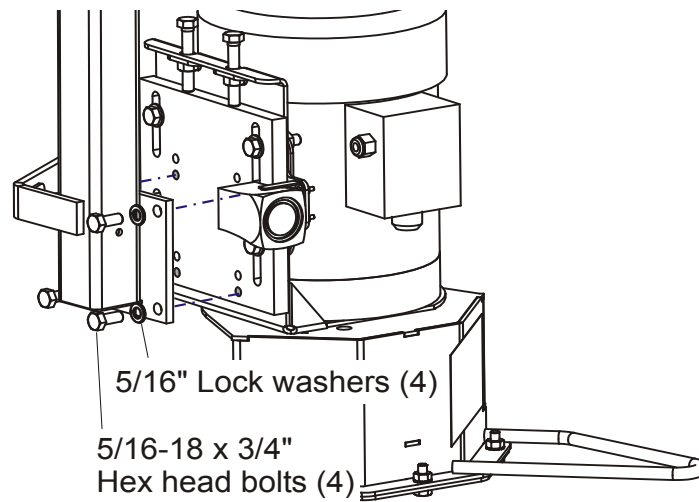

**FIG. 2-2 AC DEBARKER**

3. Install the blade guard bracket and flexible debris guard to the debarker head with two 1/4" flat washers, lock washers, and 1/4-20 x 1" hex head bolts. Be sure the bottom of the debris guard is even with the bottom of the debarker blade.

**See Figure 2-3.**



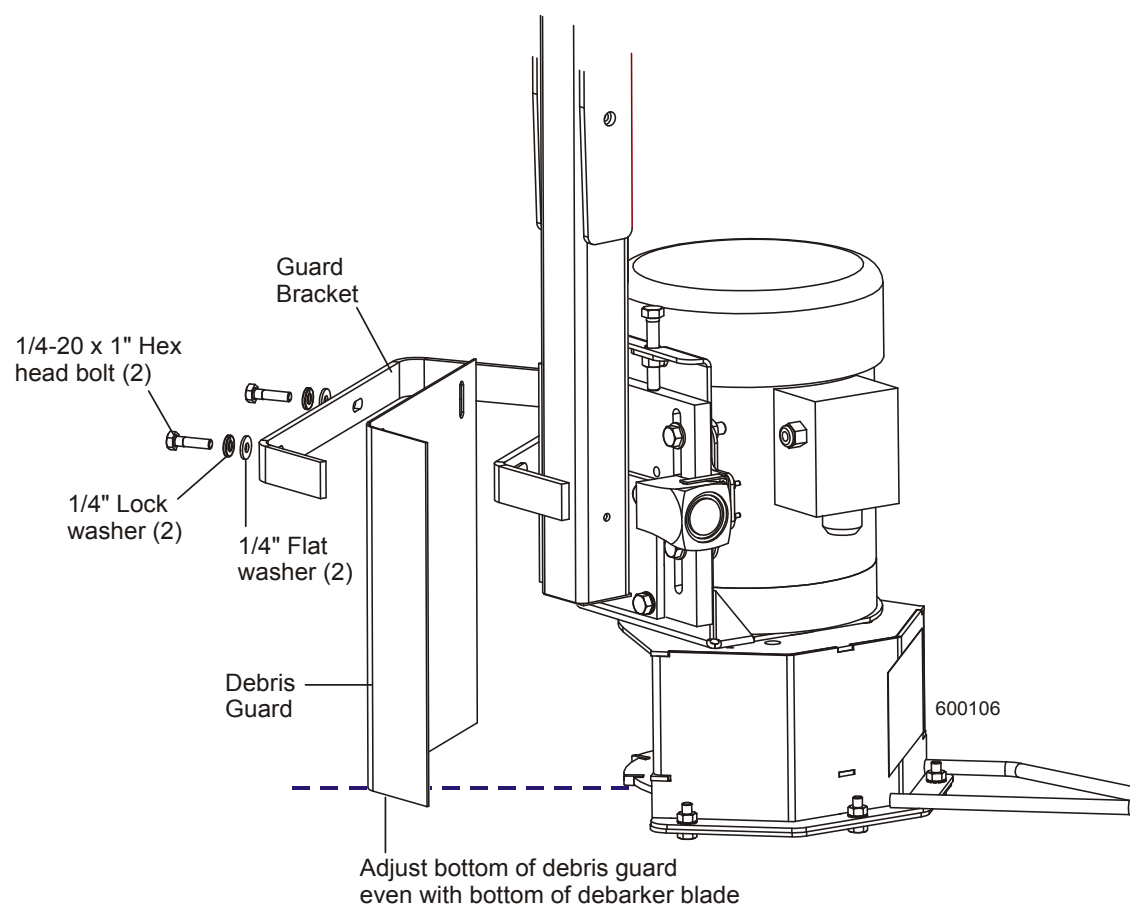

FIG. 2-3 AC DEBARKER

## 2.2 Harness Installation



**DANGER!** On electric mills, hazardous voltage inside the disconnect box, starter box, and at the electric motor can cause shock, burns, or death. Disconnect and lock out power! Follow all applicable electrical codes.



**IMPORTANT!** Avoid pinch and pivot points, unnecessary wire bending and open spaces where the wire could get caught by a log, etc. If you have any questions, call Wood-Mizer customer service.

4. Route the black wires from both the motor and warning light harnesses through one of the rubber boots and the red motor and light wires through the other rubber boot.
5. Connect the red motor and light wires to the **left motor terminal** and replace the terminal nut to secure the wires. **Reference figure 2-6.**
1. **IMPORTANT!** Insert the supplied wire harness to the debarker motor junction box. Insert the end of the harness with bare wire ends through the hole in the bottom of the debarker motor junction box and secure with the harness connector. Leave approximately 1/2" of harness conduit past the connector.

See Figure 2-4.

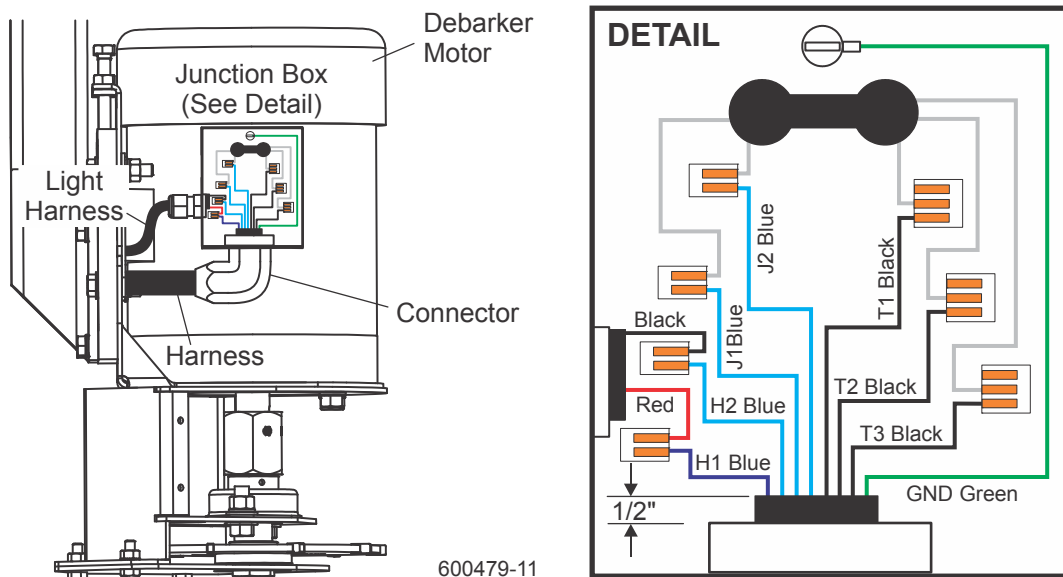

FIG. 2-4

2. Connect the harness wires to the corresponding debarker motor wires, matching the wire labels as shown. Connect the green GND wire to the ground terminal in the motor junction box.
3. Route the harness through the hole in the saw head. Locate the two-wire harness supplied with the sawmill for the debarker in/out motor. This harness is bundled with other harnesses underneath the sawmill motor. Route the two-wire harness through the hole in the saw head, toward the debarker. Connect the harness to the debarker in/out motor connector.

See Figure 2-5.

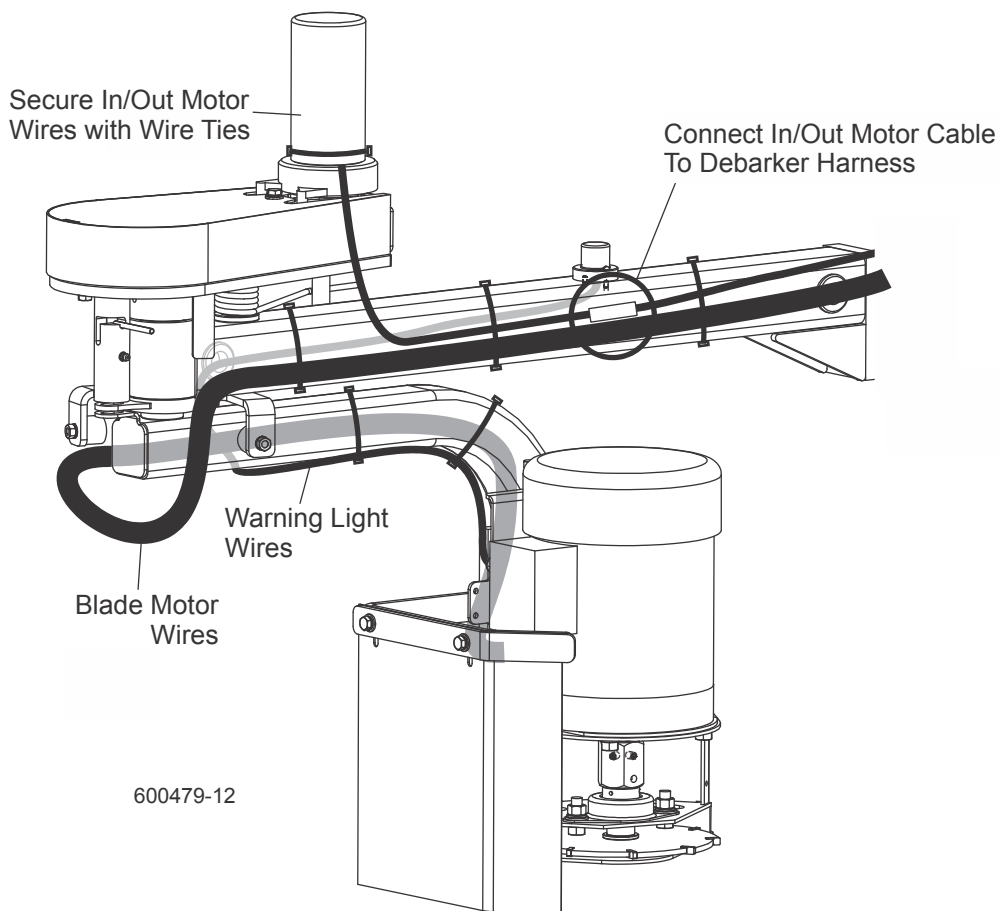

FIG. 2-5

4. Continue routing the large harness from the debarker motor under the sawmill motor, toward the electrical control cabinet. Remove the plug from the hole in the bottom of the cabinet and push the harness up into the box. Secure the harness to the cabinet hole with the provided connector, leaving approximately 1/2" of harness conduit past the connector.

# 2

## Debarker Installation

### Harness Installation

Use the provided wire tie to secure the harness to existing harnesses under the sawmill motor.

- In the control cabinet, remove the wireway covers and route the harness wires to the appropriate components.

See Figure 2-6. Only wires listed above are shown.

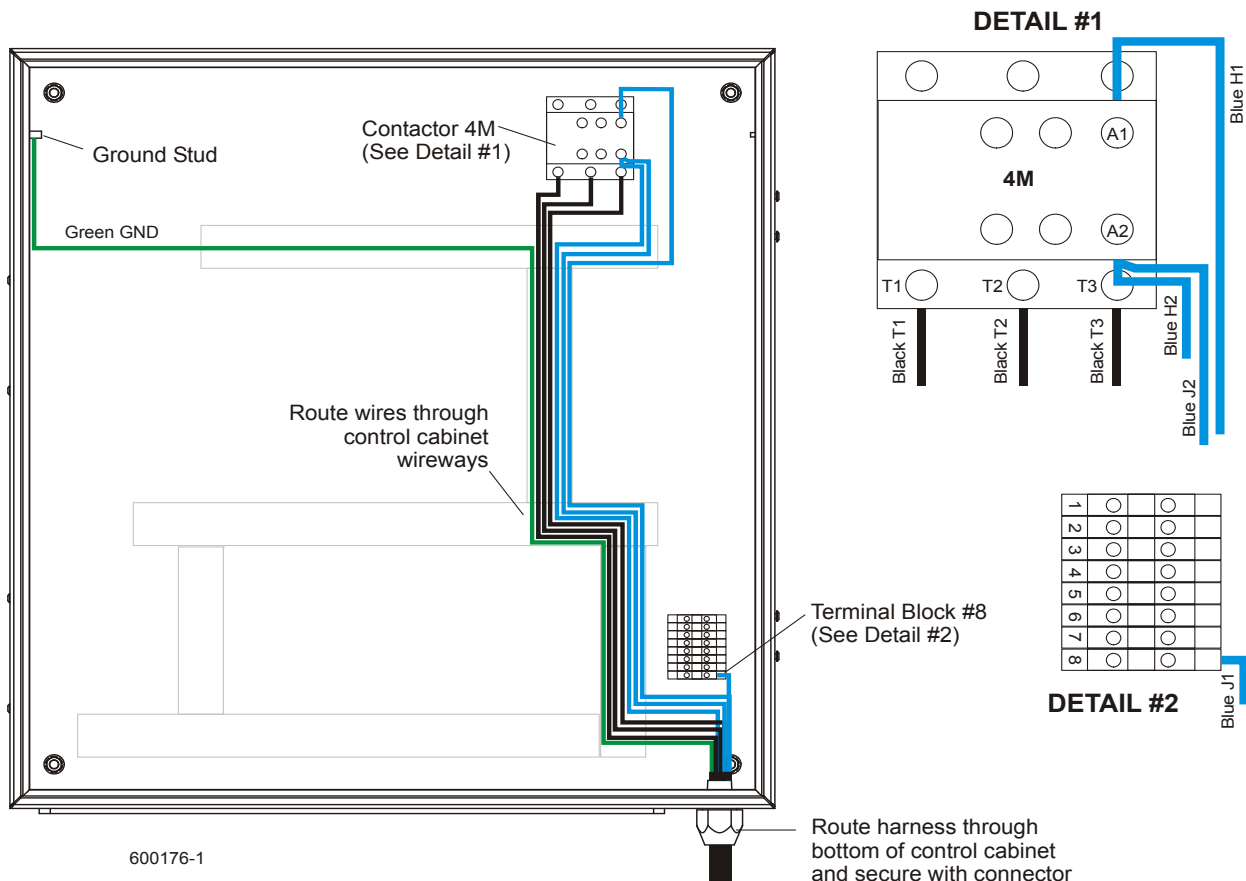

FIG. 2-6

- Connect the black T1, T2, and T3 wires to the corresponding terminals on the contactor labeled 4M at the top-right corner of the cabinet.
- Connect the green GND wire to the grounding terminal at the top-left of the control cabinet.
- Connect the blue H1 wire to the A1 terminal of the 4M contactor.
- Connect the blue J2 and H2 wires to the A2 terminal of the 4M contactor.

10. Connect the blue J1 wire to empty side of terminal block #8. Replace the wireway covers.

## 2.3 Control Component Installation



**DANGER!** On electric mills, hazardous voltage inside the disconnect box, starter box, and at the electric motor can cause shock, burns, or death. Disconnect and lock out power! Follow all applicable electrical codes.

**DANGER!** Before performing any service to this equipment, turn the key to the OFF (0) position, remove the key, and disconnect the sawmill battery ground terminal. Failure to do so will result in serious injury or death.

See SECTION 4 for the appropriate wiring diagram to aid in installation.

1. Remove the side, front and rear panels (leave wire connections) from the control box.
2. Remove the two small bolts and nuts from the back of the control box.
3. Install the provided 15 amp breaker to the two small holes in the back of the control box (position the breaker so the reset tab is near the rear opening of the control box). Use the existing screws and nuts (removed earlier) to secure in place.

See Figure 2-7.

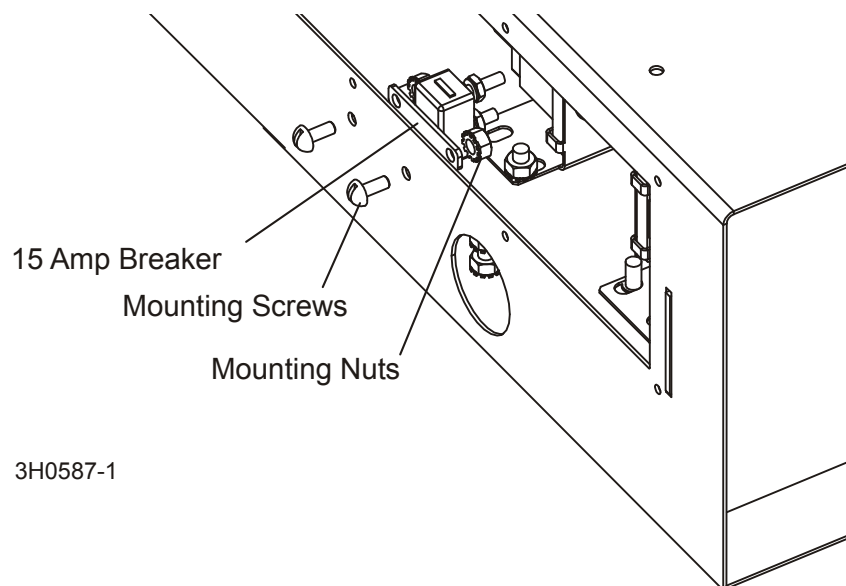

**FIG. 2-7**

- Using the back side of the front panel for a guideline, cut out holes in the front panel lexan decal for the debarker switches. Install the provided toggle switches, 1/16" nylon washers, and rubber boots in place as shown.

**See Figure 2-8.**

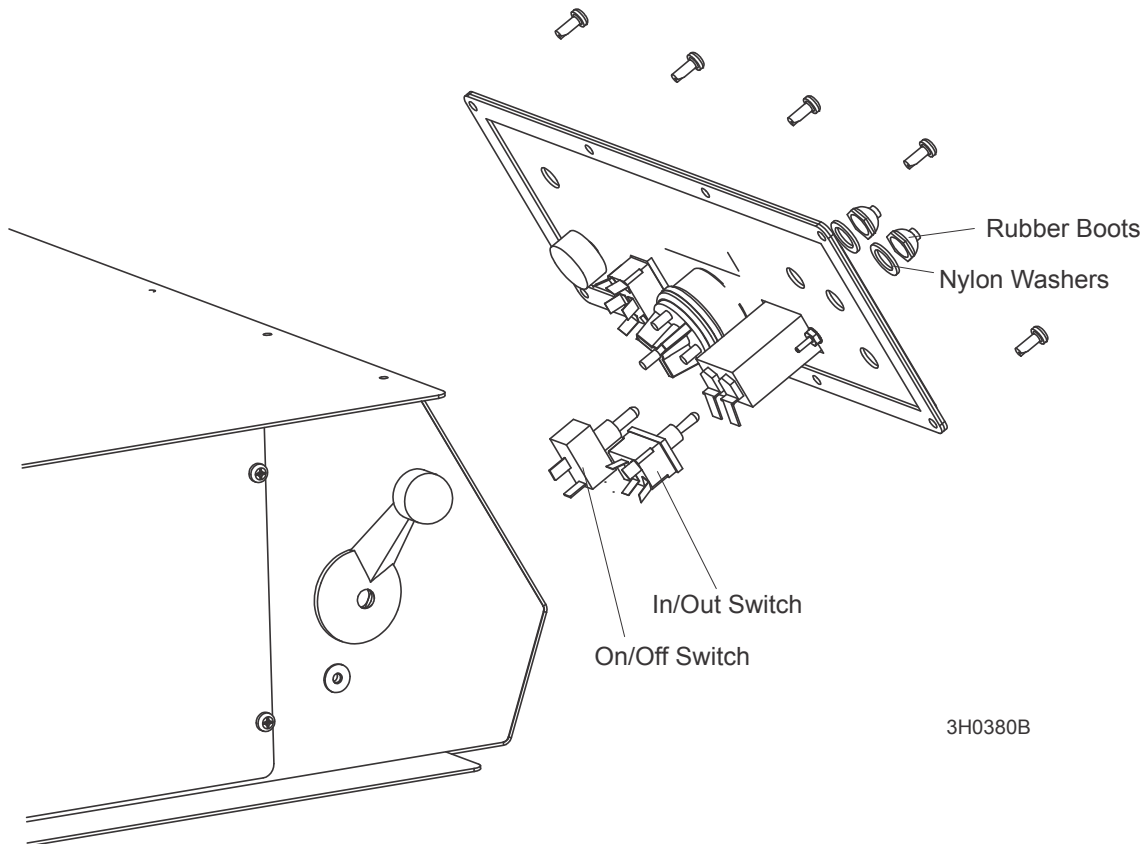

**FIG. 2-8**

## 2

### Debarker Installation

#### Control Component Installation

5. Connect the red #205 wire from the 15 amp breaker to the ACC post on the key switch.
6. Make sure the red #206 wire from the 15 amp breaker to the debarker in/out switch is connected.
7. Connect the red #208 wire from the debarker on/off switch to the DBKR terminal on the LED board. **NOTE:** If the control box is not equipped with the LED board, remove the red #208 wire from the debarker on/off switch.
8. Connect the red #200 wire from the on/off switch to terminal #3 of the existing relay socket in the control box.

See Figure 2-9. Box housing removed for clarity. Only wires referred to above are shown.

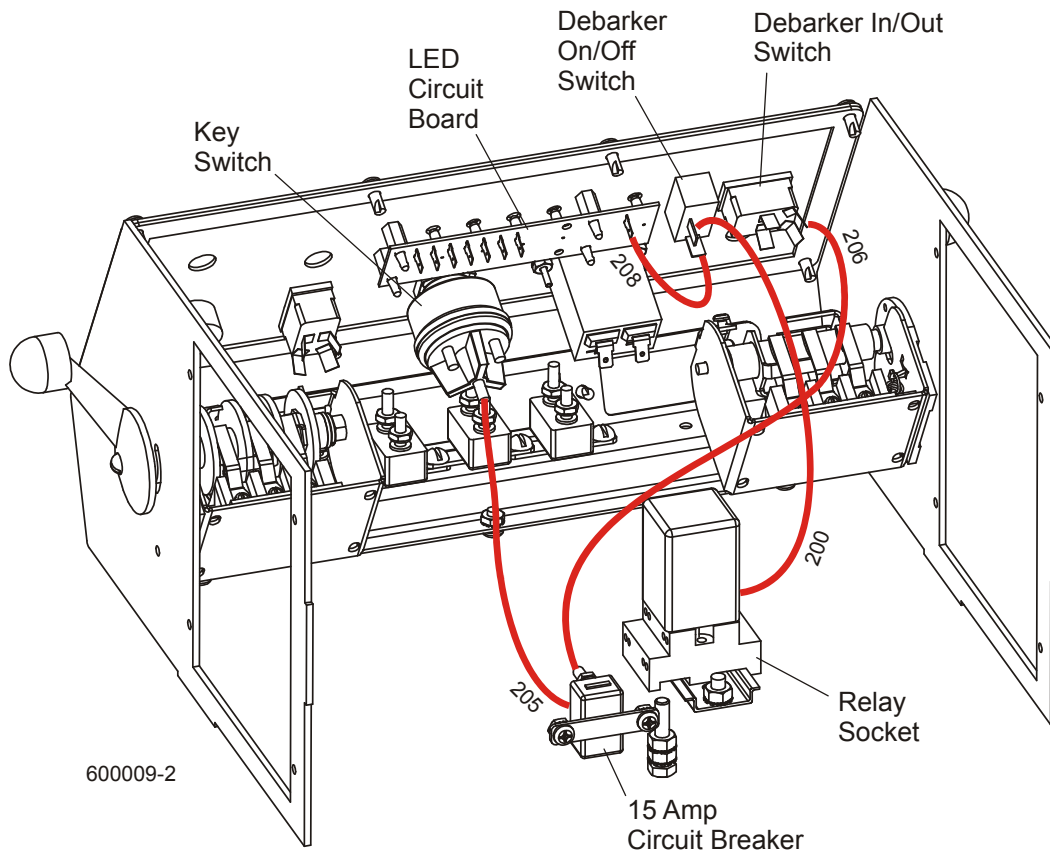
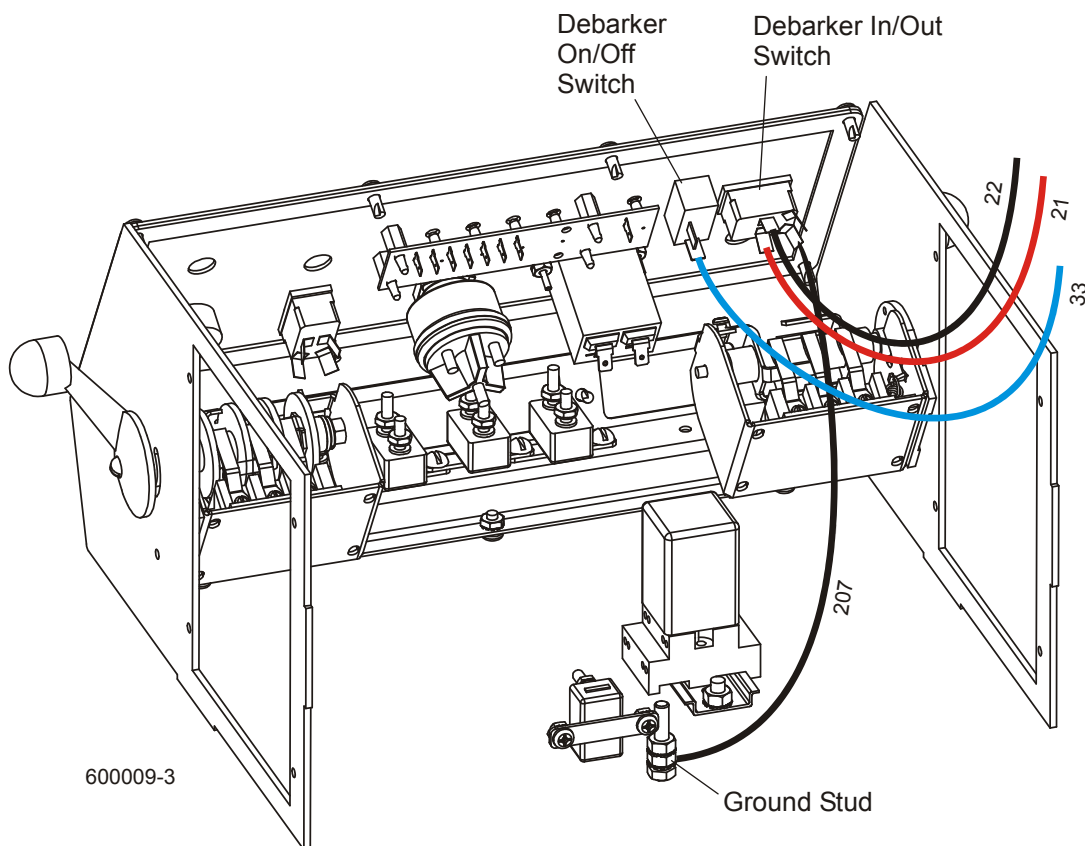

FIG. 2-9



9. Connect the black #207 wire from the debarker in/out switch to the rear ground stud.
10. Locate the bundle of wires on the floor of the sawmill control box. Make sure the debarker in/out switch is oriented horizontally as shown.
11. Connect the small red #21 wire to the debarker in/out switch bottom left terminal.
12. Connect the small black #22 wire to the debarker in/out switch top left terminal.
13. Connect wire #33 (blue on non-remotes, red on remotes) to the bottom debarker on/off switch terminal.

**See Figure 2-10.** Box housing removed for clarity. Only wires referred to above are shown.



**FIG. 2-10**

14. Reinstall the front and rear panels, side panel, and control box top cover to the control box.

## SECTION 3 ALIGNMENT



**DANGER!** Before performing any service to this equipment, turn the key to the OFF (0) position and remove the key. Failure to do so will result in serious injury or death.

The debarker blade should be aligned to the sawmill blade to insure proper operation. The debarker blade should be parallel with and aligned vertically with the sawmill blade.

1. Turn the key to ACC (3) and use the debarker in/out switch to move the debarker all the way in. Turn the key to OFF (0) and remove the key. This will prevent the debarker from being turned on while performing alignment procedures.
2. Check the squareness of the debarker with the sawmill blade. Adjust the debarker mounts if necessary until the debarker is square with the sawmill blade.

Loosen the bottom debarker mounting bolt and loosen the jam nuts on the adjustment bolts. Turn the adjustment bolts as necessary until the debarker is square with the sawmill blade. Retighten the jam nuts and bottom debarker mounting bolt.

See Figure 3-1.

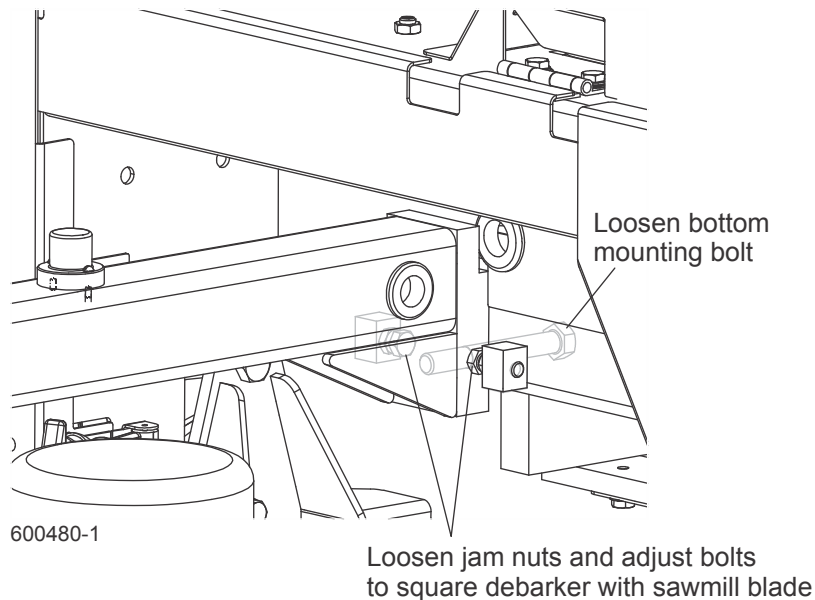

**FIG. 3-1**

- 3. Clip the blade guide alignment tool to the sawmill blade. Make sure the tool lies flat on the blade and does not contact a tooth that could cause it to angle.

See Figure 3-2.

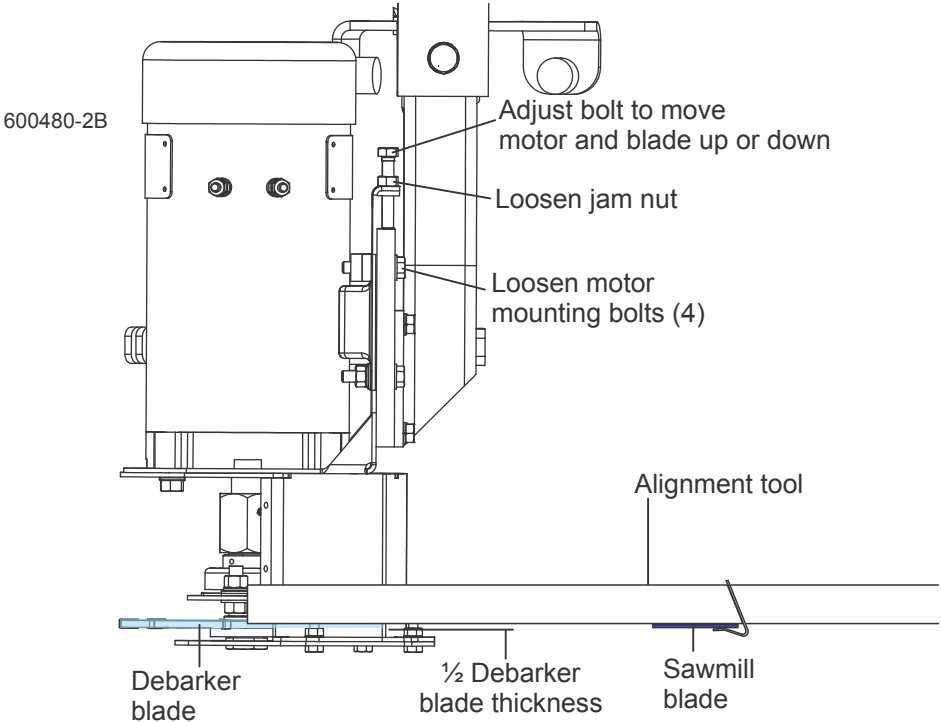

FIG. 3-2

- 4. Check the height of the debarker blade against the alignment tool. The bottom edge of the tool should align with the center of the debarker blade.
- 5. Insert the key and use the debarker in/out switch to move the debarker all the way out. Turn the key to OFF (0) and remove the key.
- 6. Move the blade guide alignment tool on the sawmill blade and check the position of the debarker blade against the tool. If the debarker blade is not centered with the tool, readjust the debarker mounting bolts to adjust the debarker assembly parallel to the blade.

## SECTION 4 OPERATION AND MAINTENANCE

### 4.1 Travel Lock Pin (Rev. A.04+)

**See Figure 4-1.** The debarker is equipped with a travel lock pin. Insert the lock pin to lock the debarker in place when towing the sawmill. Remove the lock pin to unlock the debarker while the debarking is required during sawing.

**Before operating the debarker,** make sure the lock pin is secured in its travel position. Turn the key switch to OFF (0) and remove the key. Pull the debarker out to relieve pressure on the lock pin. Remove the lock pin.

**Before towing the sawmill,** lock the debarker in the travel position. Turn the key switch to ACC (3) and use the debarker in/out switch to move the debarker all the way in. Turn the key to OFF (0) and remove the key. Push the debarker in until the travel position holes align. Insert the lock pin.

**To move the debarker out of the way during sawing,** turn the key switch to ACC (3) and use the debarker in/out switch to move the debarker all the way out.

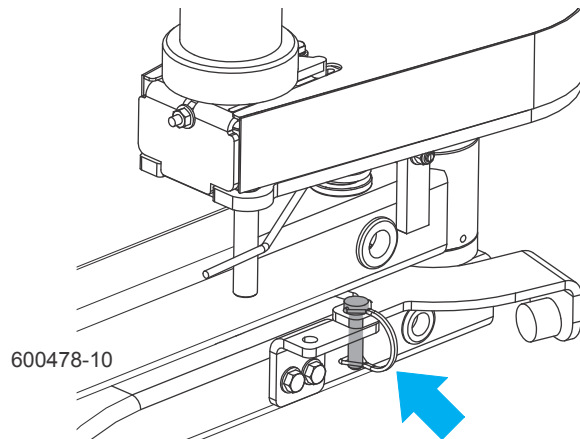

FIG. 4-1

### 4.2 Travel Lock Pin Operation (Prior to Rev. A.04)

**See Figure 4-2.** The debarker is equipped with a locking pin located where the debarker frame pivots in the mounting blocks. One hole location is provided for the locking pin. Turn the locking pin to the left to lock the debarker in place when towing the sawmill. Turn the locking pin to the right to unlock the debarker while the debarking is required during sawing.

**Before operating the debarker,** make sure the locking pin is secured in its travel position. Turn the key switch to OFF (0) and remove the key. Pull the debarker out to relieve pressure on the locking pin. Pull the pin up and rotate so the small roll pin is aligned with the disengaged position. Release the locking pin.

**Before towing the sawmill,** lock the debarker in the travel position. Turn the key switch to ACC (3) and use the debarker in/out switch to move the debarker all the way in. Turn the key to OFF (0) and remove the key. Push the debarker in until the travel position hole aligns with the locking pin. Pull the pin up and rotate until the small roll pin is aligned with the travel position slot. Release the locking pin.

**To move the debarker out of the way during sawing,** turn the key switch to ACC (3) and use the debarker in/out switch to move the debarker all the way out.

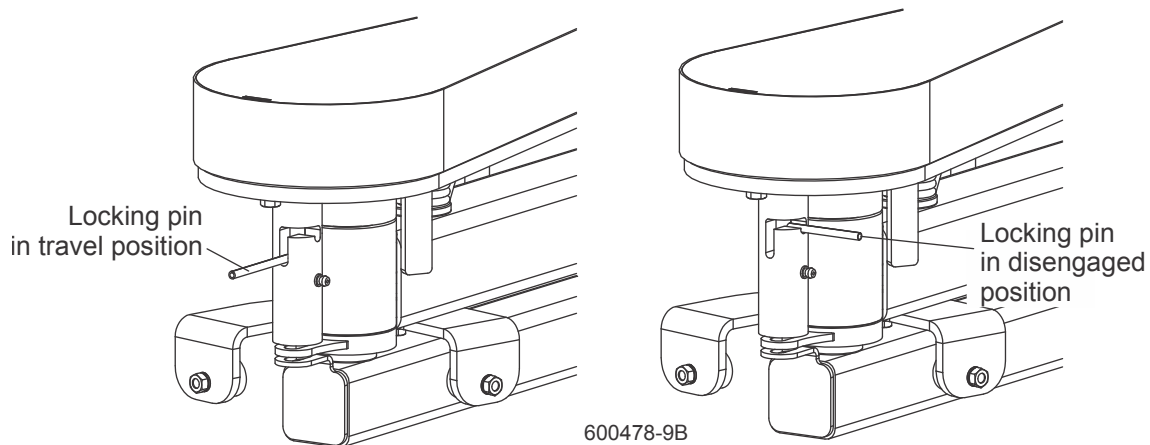
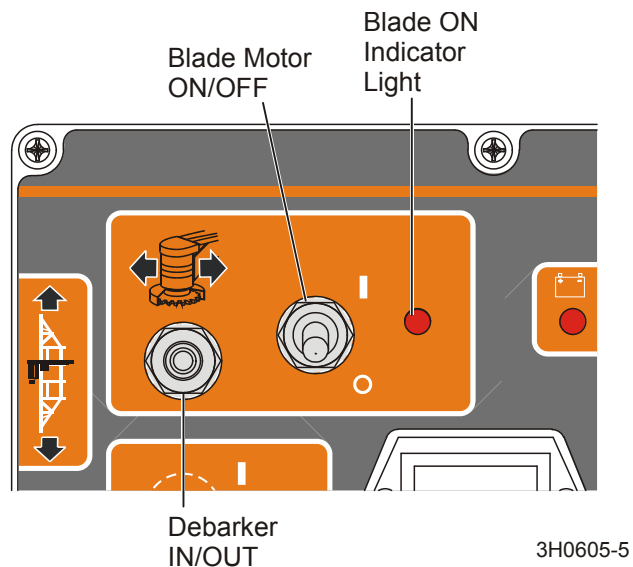

**FIG. 4-2**

### 4.3 Control Overview

The Debarker Option allows you to remove bark from logs ahead of the bandsaw blade. This prevents the bandsaw blade from contacting dirt, sand, or other debris in the bark that can dull the blade.

See **Figure 4-3**. The debarker control includes two toggle switches and an indicator light.



**FIG. 4-3**

- The Debarker IN/OUT toggle switch controls the debarker in/out motor to move the debarker cutting head toward or away from the log. The sawmill key switch must be on before the in/out function can be performed. **NOTE:** The distance between the debarker blade and the side support with the cutting head all the way in is 6" (150mm) for the sawmill equipped with the standard head and 12" (300mm) for the sawmill equipped with the wide head.
- The Blade Motor ON/OFF toggle switch turns the blade motor on to start the debarker blade. The sawmill key switch must be on and the sawmill power feed drum switch must be activated in the forward direction before the blade motor can be turned on.
- The Blade ON indicator light comes on whenever the debarker blade motor is on.

## 4.4 Operation



**DANGER!** Make sure all guards and covers are in place and secured before operating the debarker option. Failure to do so may result in serious injury.

**DANGER!** Keep all persons out of the path of moving equipment when operating the debarker. Failure to do so will result in serious injury.

1. Remove the blade motor cover before operating the debarker.
2. Make sure the warning light is on when the debarker is turned on.



**WARNING!** Debarker is ON when warning light is on. DO NOT disconnect the warning light. Doing so may result in serious injury.

3. Use the in/out switch on the control box to pivot the debarker all the way out.



4. Move the sawmill carriage forward and pivot the debarker in until the front fence engages with the end/side of the log.
5. Turn the debarker on/off switch to ON (1).



6. Proceed with cutting. The actuator will keep the debarker against the side of the log. Depending on log shape, you may have to pivot the debarker in and out for smooth cutting.



**NOTE:** The debarker can continuously remove up to approximately 1” of material from the log; no motor cool down time is required. Slower feed rates may be required for optimal debarker operation.

7. Once the carriage is past the end of the log, pivot the debarker away from the log. Return the carriage.



**IMPORTANT!** Should the carriage be returned before the debarker has been pivoted out of the way of the log, the debarker is designed to pivot upwards. If this happens, continue to **SLOWLY** return the carriage; or stop, pivot the debarker out and then return the carriage. **DO NOT** move the carriage forward while the debarker is contacting the log without the blade spinning.

8. When done sawing and ready to store or transport the sawmill, replace the debarker blade motor cover. Place the debarker in its travel position before towing the sawmill ([See Section 4.1](#)).



## 4.5 Maintenance



**DANGER!** Before performing any service to this equipment, turn the key to the OFF (0) position and remove the key. Failure to do so will result in serious injury or death.

1. Lubricate the pivot joint with a NLGI #2 grade lithium grease every 40 hours of operation.

See Figure 4-4.

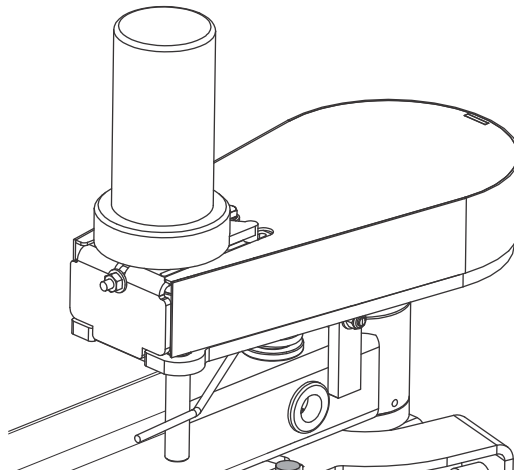

FIG. 4-4

2. Periodically check the flexible guard. Adjust the guard up or down so the bottom is even with the bottom of the debarker blade. Replace the guard as needed.
3. Periodically check the debarker blade. Align or replace as needed.



**WARNING!** Before replacing the debarker blade, move the sawmill blade guide arm in front of the sawmill blade to cover the blade teeth. Failure to do so may result in serious injury or death.

To replace the debarker blade, remove the lower blade guard plate. Place one wrench on the blade arbor, above the blade bearing. Place the other wrench on the lower bolt and rotate clockwise (bolt has left-hand threads). Remove the bolt and washer. Remove the blade and spacer.

Reinstall the spacer with the new blade. Reinstall the bolt and washer and turn counter-clockwise to tighten to 35 foot-pounds ( $\pm 5$ ). Reinstall the blade guard plate.

# 3

## Operation & Maintenance

### *Maintenance*

---



**CAUTION!** Tighten the blade bolt manually. Using power-assisted tools may result in over-torquing and damage to the bolt.

## 4.6 Troubleshooting



**DANGER!** Before performing any service to this equipment, turn the key to the OFF (0) position, remove the key, and disconnect the sawmill battery ground terminal. Failure to do so will result in serious injury or death.

PROBLEM	CAUSE	SOLUTION
<b>70 amp circuit breaker tripping</b>	Wood or bark jammed in blade guard	Turn key to OFF position, remove key. Remove wood or bark from blade guard
	Pivot pin is binding.	Inspect for bind by moving debarker head to full in position. Turn key to OFF position, remove key. Pull arm to full out position by hand. If available, use a weight scale to pull arm to full out position. Should not have more than 12 pounds of resistance to pull out. Ensure pivot pin has been greased properly. Check pivot clamps for correct installation. Loosen pivot clamp bolts slightly, check for reduced binding
	Ring terminal of red wire touching debarker motor housing at motor	Move terminal away from motor housing. Reset circuit breaker and retest.
<b>Light comes on, but debarker motor and warning light do not operate</b>	Circuit breaker weak from repeated tripping.	Replace circuit breaker
	Circuit breaker tripped	Reset circuit breaker.
<b>Debarker shuts off, but the circuit breaker is not tripped.</b>	Bad ignition wire connection	Check ignition wire connection outside and inside of debarker control box.
	Intermittent key switch	Replace key switch
	Other loose wiring connection	Check wiring connections inside control box.
<b>Debarker will not shut off.</b>	Solenoid is stuck closed.	Replace solenoid.
<b>IN/OUT Motor does not move IN or OUT</b>	Drive belt too loose	Tighten enough to allow movement. DO NOT OVER-TIGHTEN.
	Switch not working properly	Check wiring to switch for loose connections. If wiring looks OK, replace switch.

## SECTION 5 ELECTRICAL INFORMATION

### 5.1 Electrical Symbol Diagram (Non-Remote)

*Low Voltage*

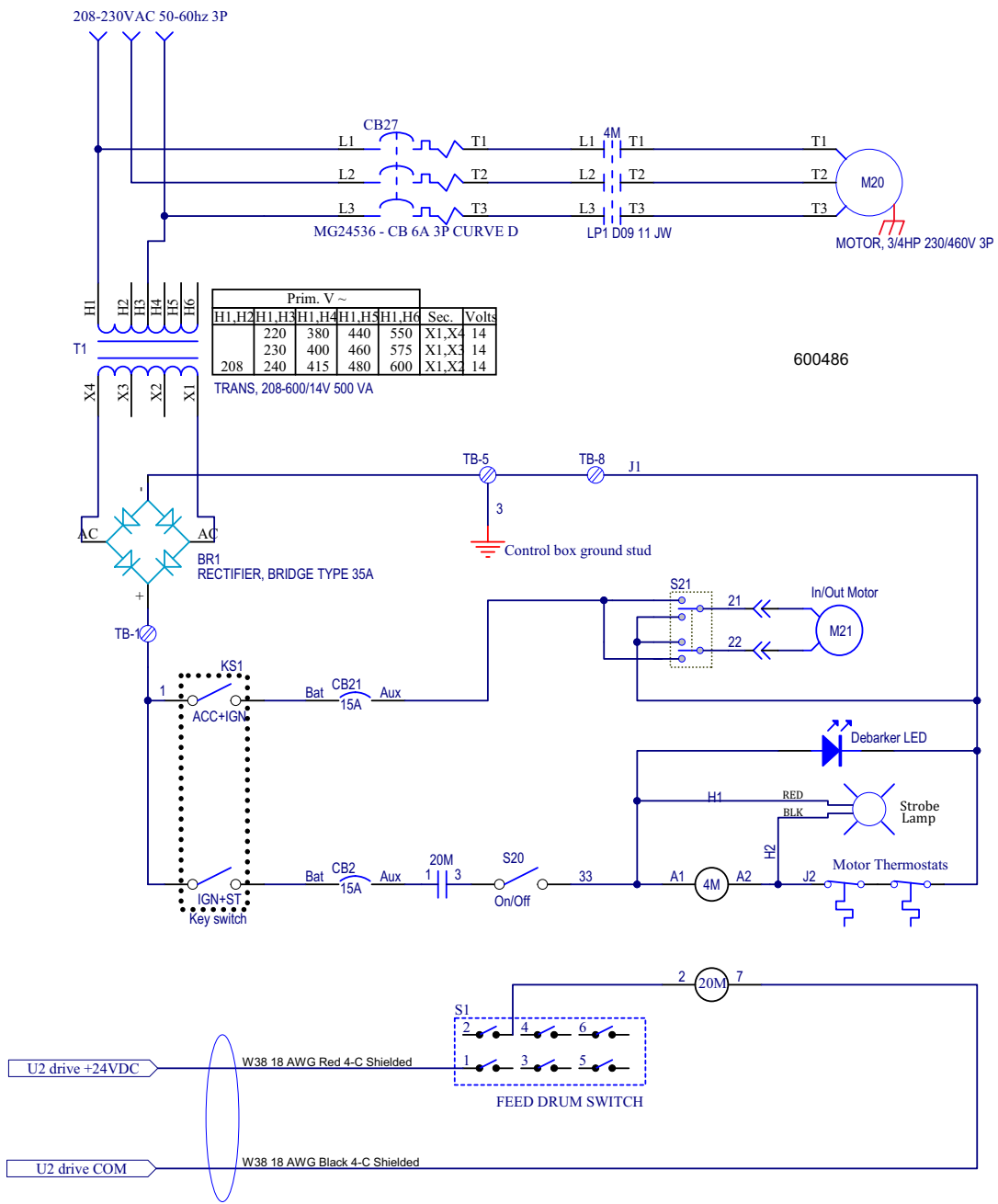

**FIG. 5-1**

**High Voltage**

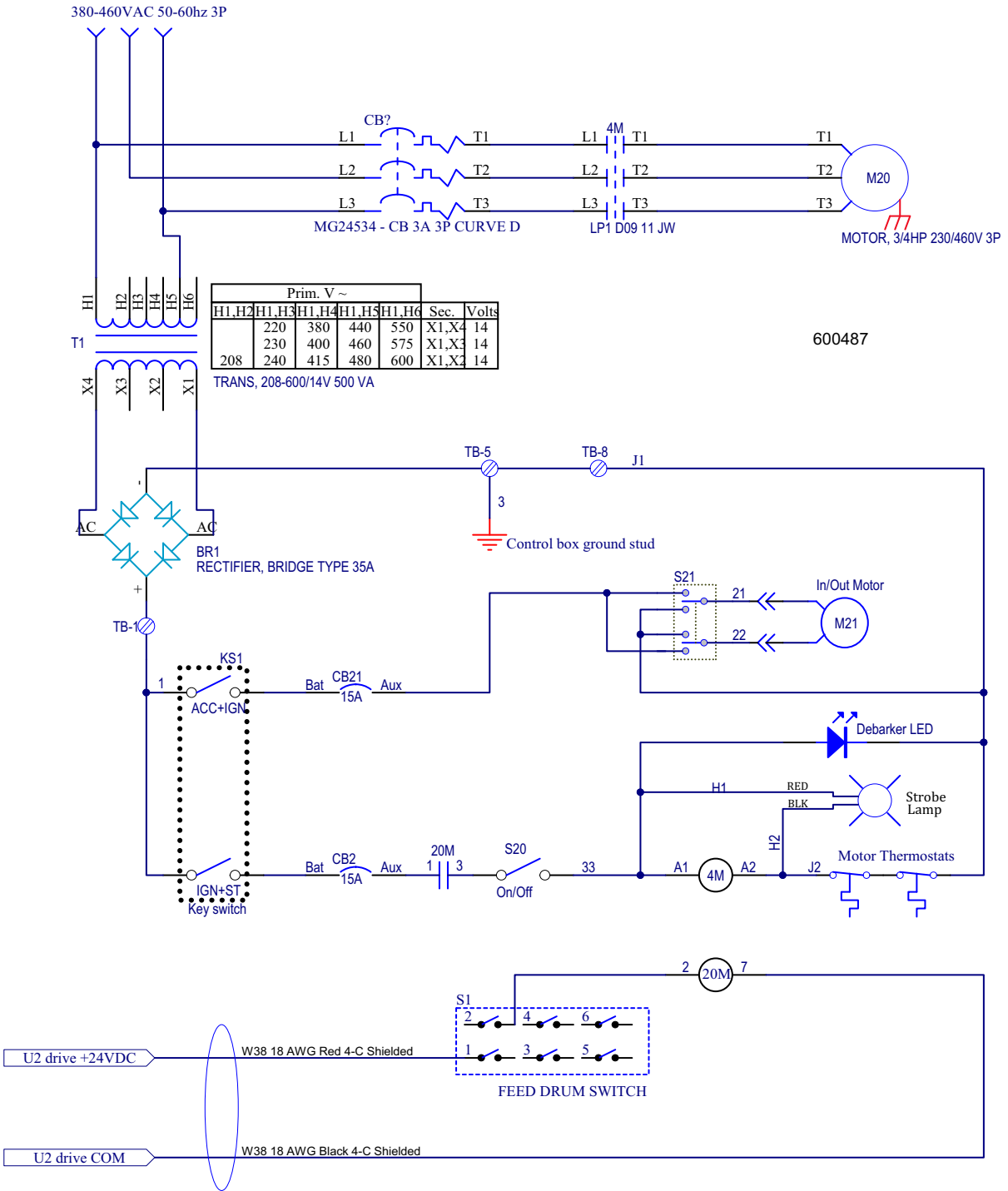

**FIG. 5-2**

## 5.2 Electrical Symbol Diagram (Remote)

### Low Voltage

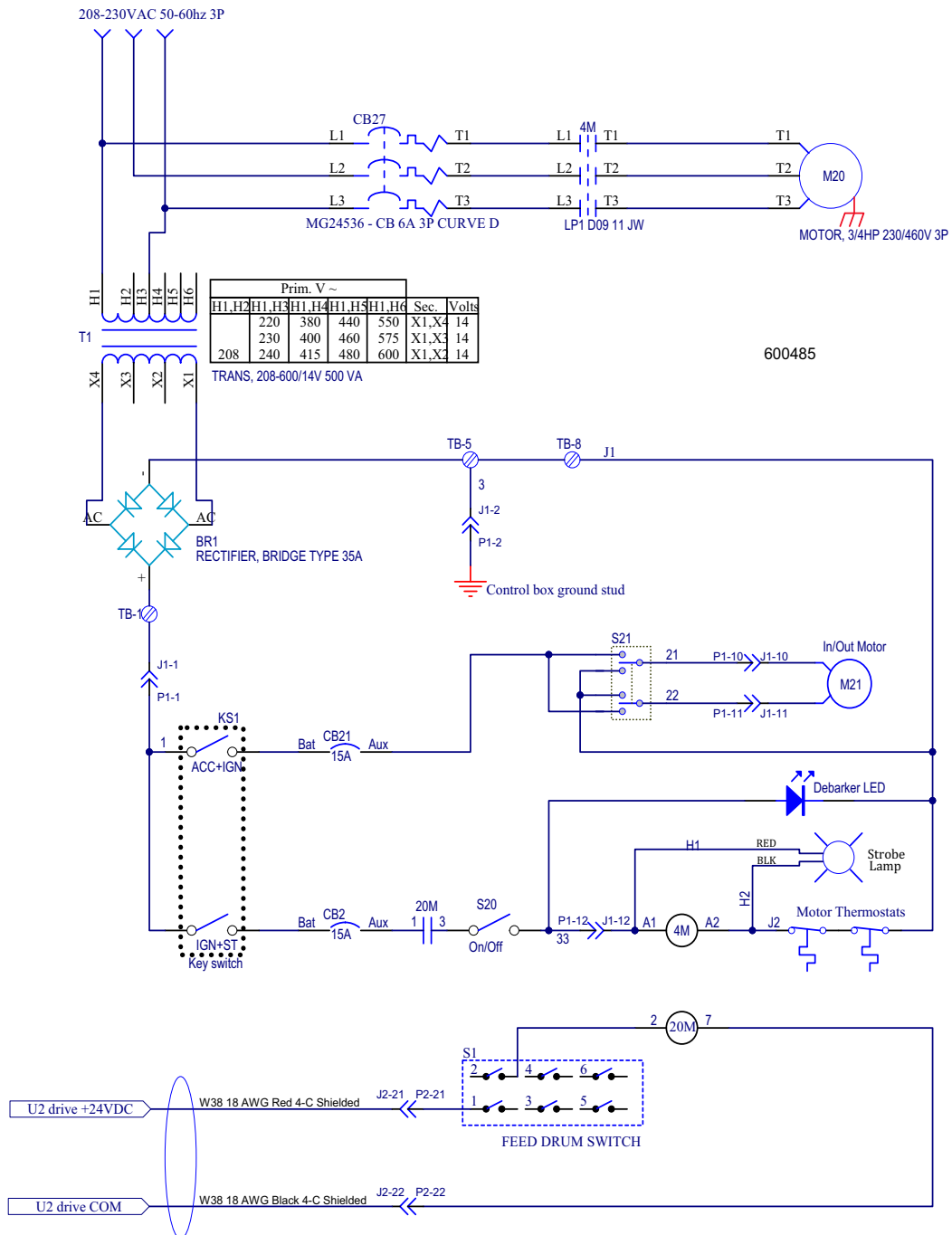
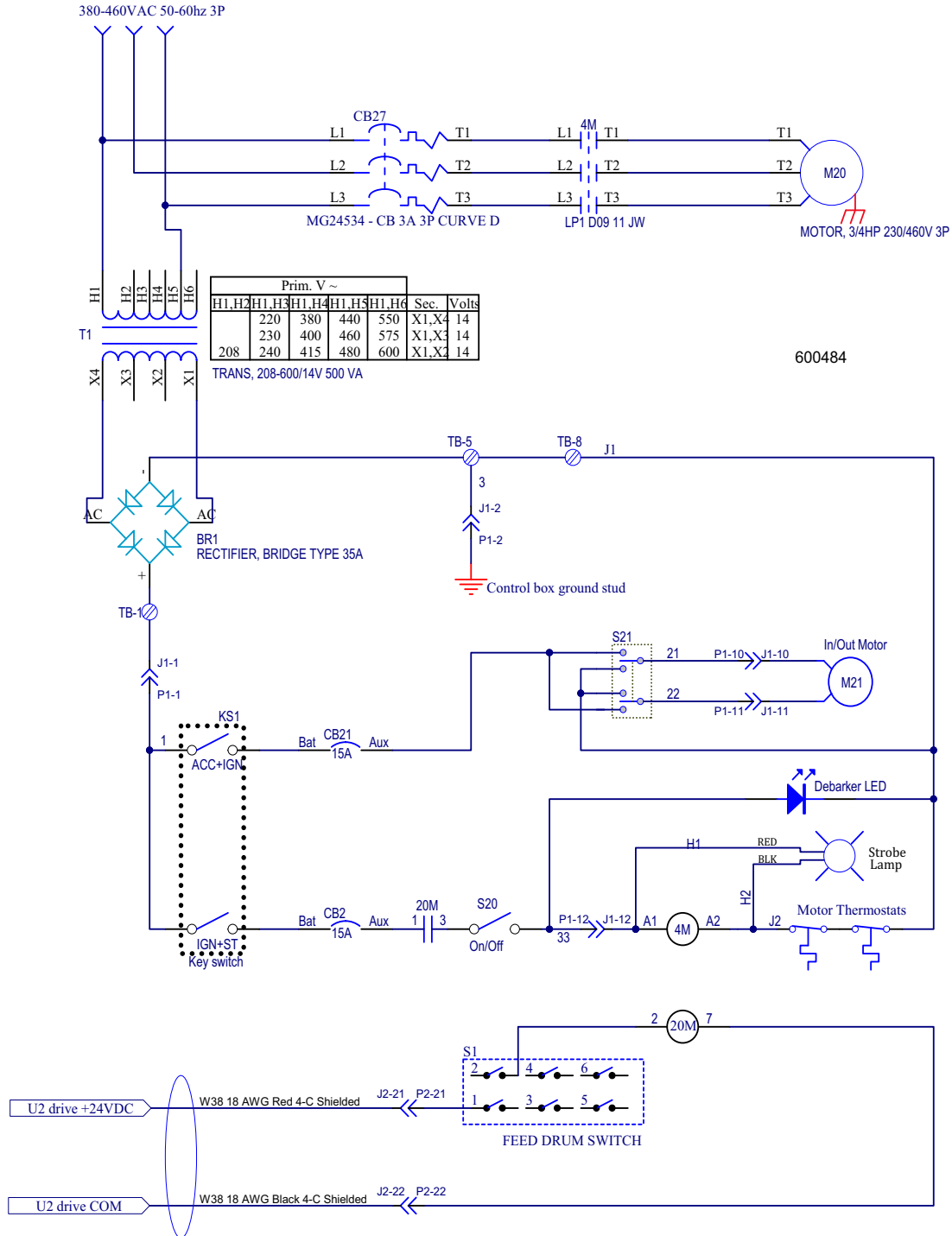

FIG. 5-3

**High Voltage**



**FIG. 5-4**

### 5.3 Electrical Component List

ID	Wood-Mizer Part No.	Description
CB21	E20430	Breaker, 15 Amp
L1	073555	Light Assembly, Debarker ON Warning Strobe
M20	050292	Motor, 3/4HP 230/460 3P 1725RPM
M21	074826	Gearmotor Assembly, LT70 Debarker In/Out
S20	P03027	Switch, Toggle
S21	024200	Switch, DPDT Toggle





## 5.5 Electrical Wiring Diagram (Remote Sawmills)

*Low/High Voltage*

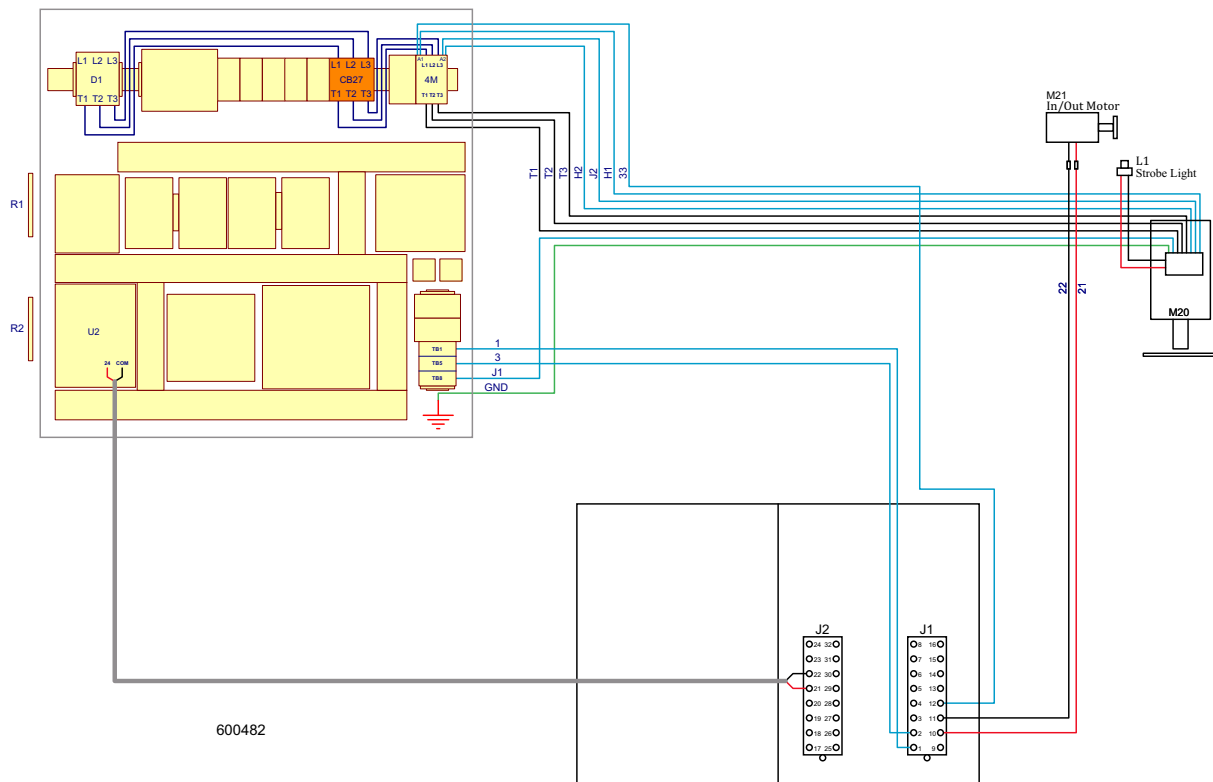

**FIG. 5-6 (PAGE 1 OF 2)**

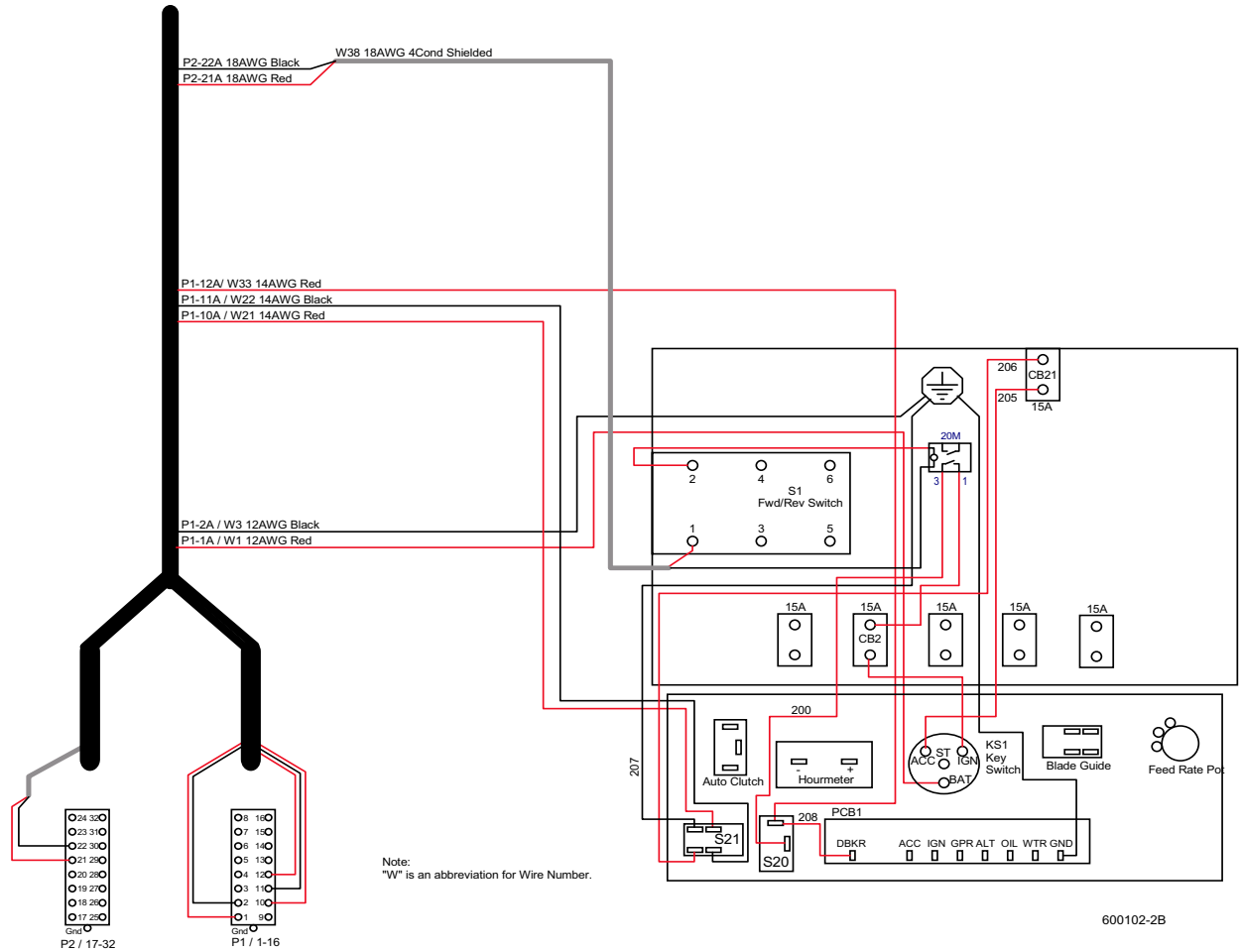

FIG. 5-7 (PAGE 2 OF 2)

# 5 Electrical Information

## Electrical Wiring Diagram (AC Wireless Sawmills)

### 5.6 Electrical Wiring Diagram (AC Wireless Sawmills)

Low/High Voltage

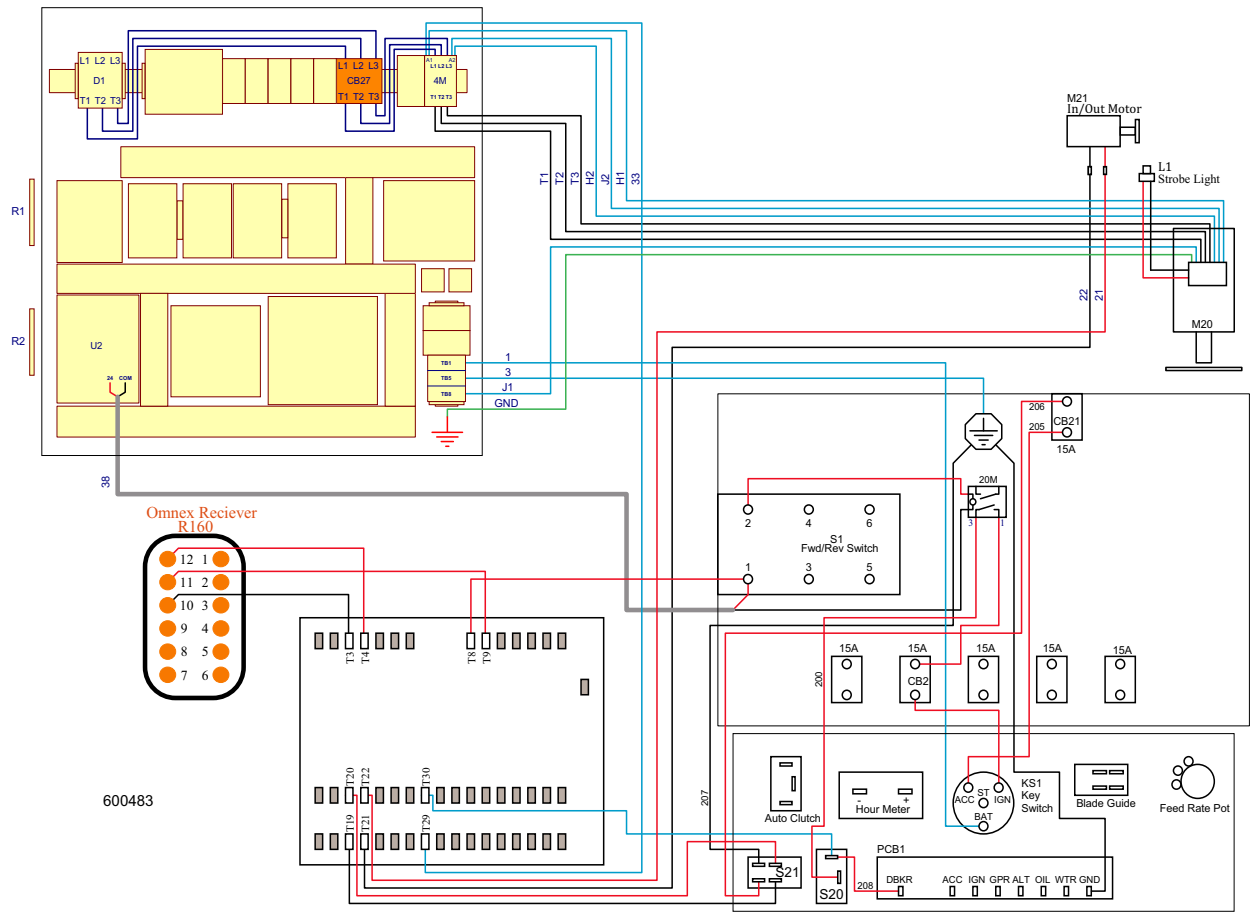

FIG. 5-8

## SECTION 6 DEBARKER PARTS

# 6 Debarker Parts

## Mechanical Assembly (AC)

### 6.1 Mechanical Assembly (AC)

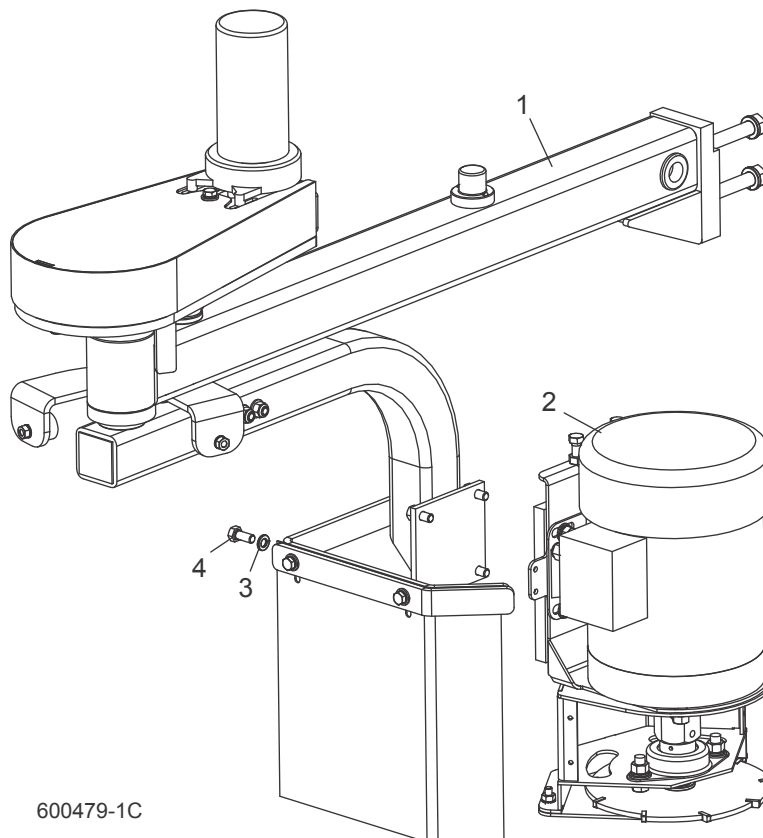

REF	DESCRIPTION (◆ Indicates Parts Available In Assemblies Only)	PART #	QTY.
	<b>NOTE: For field installation of existing sawmills, order the mechanical assembly below plus the appropriate control kit (<a href="#">See Section 6.6</a>):</b>		
	<b>MECHANICAL ASSEMBLY, 70HD AC DEBARKER (BOXED)</b>	074883	1
	<b>MECHANICAL ASSEMBLY, 70HD WIDE AC DEBARKER (BOXED)</b>	074720	1
	Debarker Assembly, LT70 AC Mechanical	074860	1
	Debarker Assembly, LT70 Wide AC Mechanical	074860W	1
<b>1</b>	Frame Parts ( <a href="#">See Section 6.2</a> )		
<b>2</b>	Cutter Head Parts ( <a href="#">See Section 6.4</a> )		
<b>3</b>	Washer, 5/16" Split Lock	F05011-13	4
<b>4</b>	Bolt, 5/16-18 x 3/4" Hex Head	F05006-5	4
	Plate, LT70 Wide Debarker Pivot Stop	076683	1
	Cover, 3/4HP Leeson Motor	015761	1

## 6.2 Frame Assembly (AC)

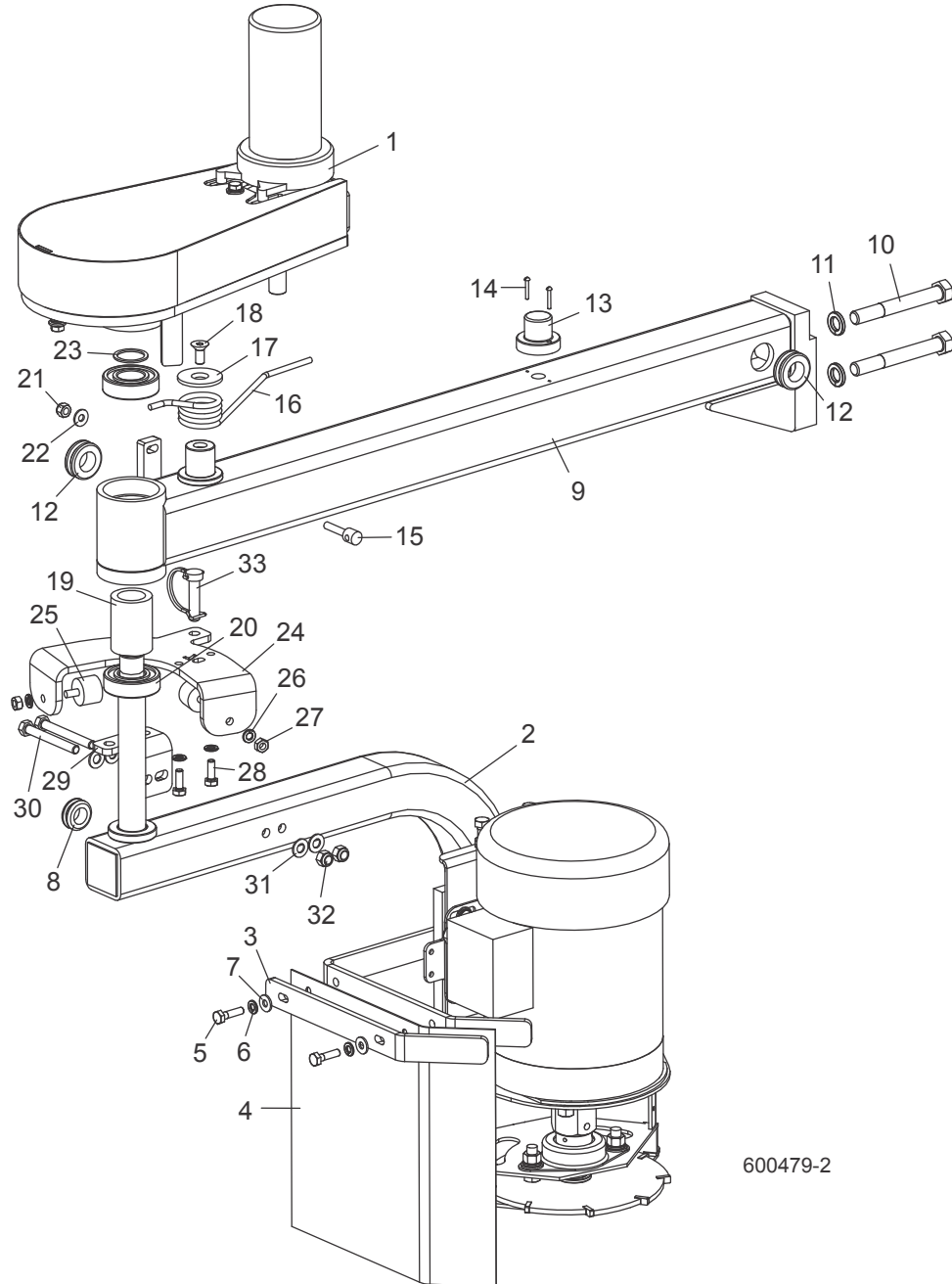

600479-2

REF	DESCRIPTION (◆ Indicates Parts Available In Assemblies Only)	PART #	QTY.
<b>1</b>	<b>DEBARKER IN/OUT MOTOR PARTS</b> ( <a href="#">See Section 6.3</a> )		
	<b>PIVOT ARM ASSEMBLY, LT70 AC DEBARKER</b>	110640	1
<b>2</b>	Arm Weldment, LT70 Debarker Pivot	110638	1
<b>3</b>	Plate, Debarker Flex Guard Retaining	076749	1

## 6

## Debarker Parts

### Frame Assembly (AC)

4	Guard, Debarker Flex	021232	1	
5	Bolt, 1/4-20 x 1" Hex Head	F05005-38	2	
6	Washer, 1/4" Split Lock	F05011-14	2	
7	Washer, 1/4" SAE Flat	F05011-11	2	
8	Grommet, 5/8" ID 3/16" GW Rubber	033475	1	
	AC Cutter Head Parts ( <a href="#">See Section 6.4</a> )			
	<b>MOUNT ARM ASSEMBLY, LT70 DEBARKER</b>	110648	1	
9	Mount Arm Weldment, LT70 Debarker	110647	1	
10	Bolt, 1/2-13 x 4" Hex Head Grade 5	F05008-78	2	
11	Washer, 1/2" Split Lock	F05011-9	2	
12	Grommet, Rubber 3/4 ID	025247	2	
13	Lamp Assembly, 180 Degree Amber Strobe	073555	1	
14	Bolt, 4-40 x 3/4 SI	F05004-13	2	
15	Bushing, Debarker Spring Retaining	076139	1	
16	Spring, Debarker Tension	098605	1	
17	Washer, LT35 Torsion Spring	076039	1	
18	Bolt, 5/16-18 x 3/4" FHS	F05006-95	1	
19	Tube, Long Bearing Spacer	076739	1	
20	Bearing, SKF 6205 2RS Roller	087353	2	
21	Nut, 1/4-20 Nylock	F05010-69	1	
22	Washer, 1/4" SAE Flat	F05011-11	1	
23	<b>SHIM, 1 ID 1-1/4" OD</b>	076037	1	
	<b>STOP ASSEMBLY, LT70 DEBARKER PIVOT</b>	074878	1	
	<b>STOP ASSEMBLY, LT70 WIDE DEBARKER PIVOT (WIDE HEAD ONLY)</b>	074879	1	
24	Plate, LT70 Debarker Pivot Stop	076682	1	
	Plate, LT70 Wide Debarker Pivot Stop (Wide Head Only)	076683	1	
25	Bumper, 1 x 3/4" Hard Silicone Rubber	065717	2	
26	Washer, 1/4" Split Lock	F05011-14	2	
27	Nut, 1/4-20 Free	F05010-63	2	
28	Bolt, 1/4-20 x 3/4" Hex Head Grade 5	F05005-123	2	
29	<b>LOCK BRACKET, DEBARKER TRAVEL</b>	110616	1	
30	<b>BOLT, 5/16-18X2 3/4 FT HH GR5</b>	F05006-136	2	
31	<b>WASHER, 5/16 SAE FLAT</b>	F05011-17	4	
32	<b>NUT, 5/16-18 NYLOK HEX</b>	F05010-58	2	
33	<b>PIN, 3/8X1 3/8 ROUND WIRE LOCK</b>	046412	1	



### 6.3 In/Out Motor Drive Assembly

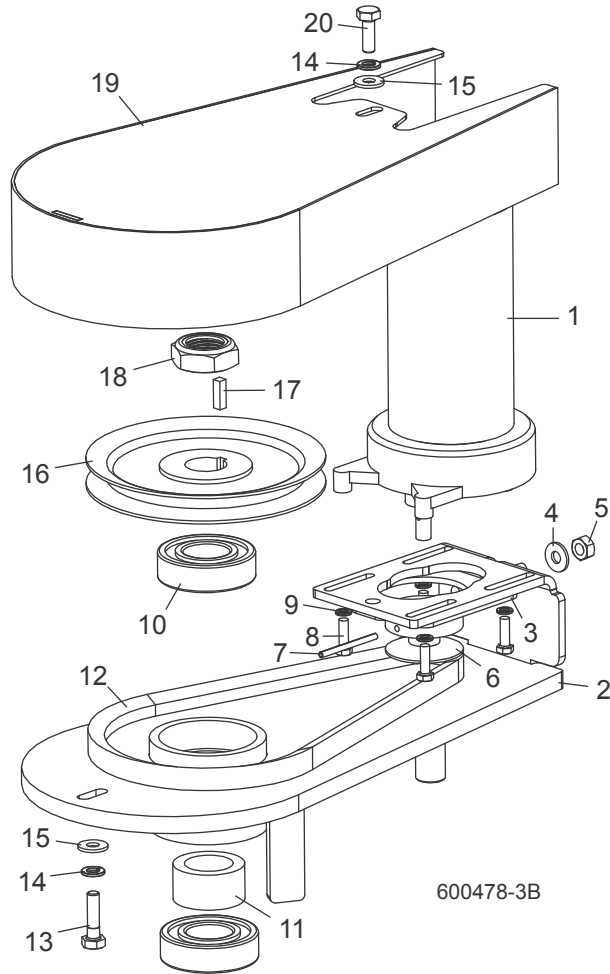

REF	DESCRIPTION (◆ Indicates Parts Available In Assemblies Only)	PART #	QTY.	
	<b>PIVOT ASSEMBLY, LT70 DEBARKER UPPER</b>	110634 <sup>1</sup>	1	
<b>1</b>	Gearmotor Assembly, LT70 Debarker In/Out	114024 <sup>3</sup>	1	
	Gear Kit, Motor	061228	1	
	Shaft Kit, Motor	061229	1	
	Brush Kit, Motor	061230	1	
<b>2</b>	Pivot Weldment, LT70 Debarker Upper	110635	1	
<b>3</b>	Tensioner Weldment, Gear Motor	023637	1	
<b>4</b>	Washer, 1/4" SAE Flat	F05011-11	1	
<b>5</b>	Nut, 1/4-20 Swaged	F05010-21	1	
<b>6</b>	Sheave, LT70 Debarker Gearmotor	076666	1	
<b>7</b>	Pin, 1/8 x 1 5/8 Roll	F05012-102	1	
<b>8</b>	Screw, 10-32 x 5/8 HH Machine	F05004-152	4	
<b>9</b>	Washer, #10 Split Lock	F05011-20	4	

## 6

**Debarker Parts***In/Out Motor Drive Assembly*

10	Bearing, SKF 6205 2RS Roller	087353	2	
11	Tube, Short Bearing Spacer	076741	1	
12	<b>BELT, AX22</b>	076689 <sup>2</sup>	1	
13	<b>BOLT, 1/4-20 X 1" HEX HEAD GRADE 5</b>	F05005-101	1	
14	<b>WASHER, 1/4" SPLIT LOCK</b>	F05011-14	2	
15	<b>WASHER, 1/4" SAE FLAT</b>	F05011-11	2	
16	<b>PULLEY, 5X7/8 A GROOVE</b>	076798	1	
17	<b>KEY, 3/16" SQ X 5/8"</b>	065214	1	
18	<b>NUT, 7/8-14 HALF NYLOCK</b>	F05010-238	1	
19	<b>GUARD WELDMENT, LT70 DEBARKER BELT</b>	076713	1	
20	<b>BOLT, 1/4-20 X 3/4" FULL THREAD HHC</b>	F05005-1	1	

<sup>1</sup> 110634 replaced 074825 Pivot Assembly and 110635 replaced 076709 Pivot Weldment (Rev. A.04).

<sup>2</sup> Changed belt from AX21 to AX22 (Rev. A.02).

<sup>3</sup> Motor 074826 replaced with 128026 in 7/19 per ECN 35985. Motor 128026 replaced with motor 114024 in 9/19 per ECN 36082.

## 6.4 Blade Motor Assembly (AC)

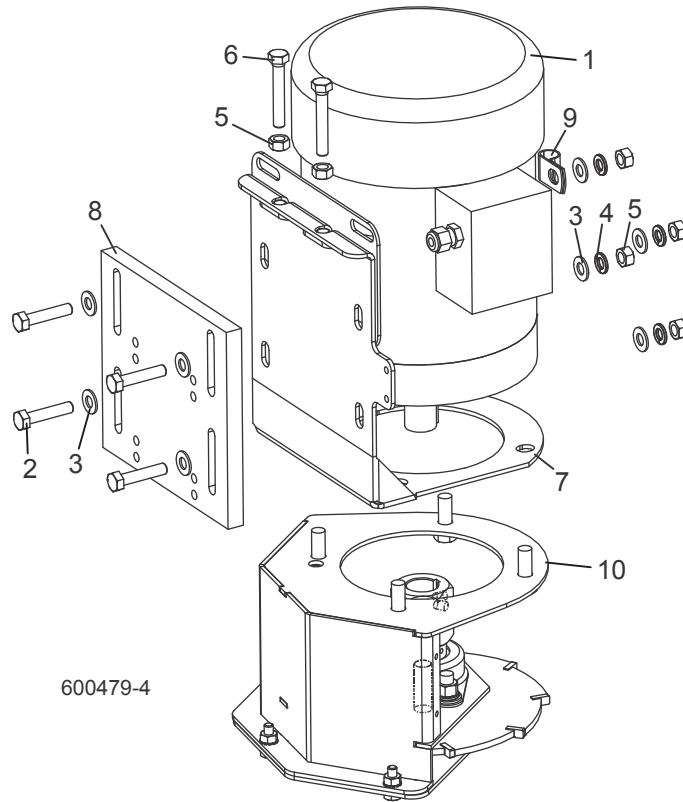

REF	DESCRIPTION (◆ Indicates Parts Available In Assemblies Only)	PART #	QTY.	
	<b>HEAD ASSEMBLY, LT70 AC DEBARKER CUTTING</b>	074858	1	
<b>1</b>	Motor, 3/4HP 230/460V 1725RPM Electric	050292	1	
	Key, 3/16" Square x 1 3/8" Long	016108	1	
<b>2</b>	Bolt, 5/16-18 x 1 1/2" Hex Head Full Thread	F05006-2	4	
<b>3</b>	Washer, 5/16" SAE Flat	F05011-17	8	
<b>4</b>	Washer, 5/16" Split Lock	F05011-13	4	
<b>5</b>	Nut, 5/16-18 Hex	F05010-17	6	
<b>6</b>	Bolt, 5/16-18 x 2" Hex Head Full Thread	F05006-13	2	
<b>7</b>	Bracket Weldment, Debarker Blade Motor Adjustable	023622	1	
<b>8</b>	Plate, Debarker Blade Motor Mount	023620	1	
<b>9</b>	Clamp, 1/2EMT Coated	P07584	1	
	Decal, Disconnect Motor Leads Warning	024431	1	
<b>10</b>	Blade/Mandrel Parts ( <a href="#">See Section 6.5</a> )			

# 6 Debarker Parts

## Blade Housing Assembly

### 6.5 Blade Housing Assembly

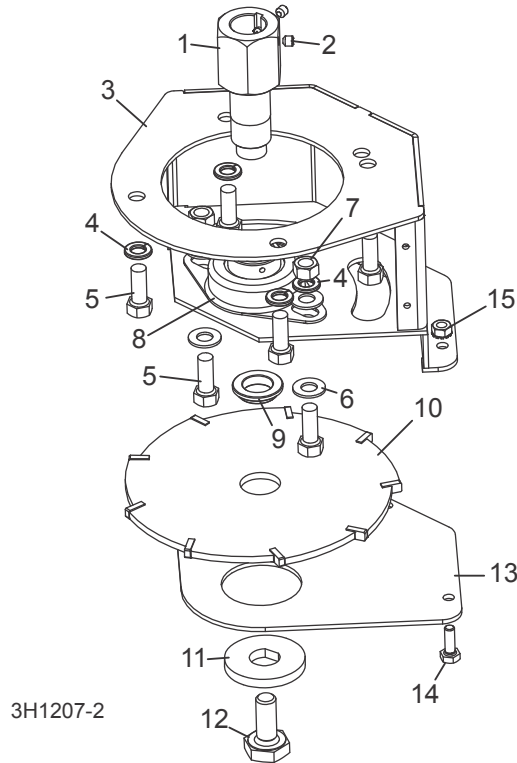

REF	DESCRIPTION (◆ Indicates Parts Available In Assemblies Only)	PART #	QTY.
1	MANDREL, DEBARKER BLADE	074832	1
2	SCREW, 1/4-28 X 1/4" CUP POINT SOCKET SET	F05005-105	2
3	HEAD WELDMENT, LT70 DEBARKER CUTTER	076686	1
4	WASHER, 3/8" SPLIT LOCK	F05011-4	6
5	BOLT, 3/8-16 X 1" HEX HEAD	F05007-7	6
6	WASHER, 3/8" SAE FLAT	F05011-3	4
7	NUT, 3/8-16 HEX	F05010-1	2
8	BEARING, 1" FLANGED MOUNT	023541	1
9	BUSHING, DEBARKER BLADE SPACER	023632	1
10	BLADE, DEBARKER 7" DIA.	021236	1
	BLADE, DEBARKER 7" DIA. W/1/2" INSERTS (OPTIONAL - SOLD SEPARATELY)	065852	1
11	WASHER, DEBARKER BLADE LOCK	023737	1
12	BOLT, 1/2-20 X 1 1/4" HEX HEAD SPECIAL	074833	1
13	PLATE, DEBARKER BLADE HOUSING BOTTOM	023629	1
14	BOLT, 1/4-20 X 3/4" HEX HEAD FULL THREAD	F05005-1	3
15	NUT, 1/4-20 SELF-LOCKING HEX	F05010-9	3
	DECAL, DEBARKER LIGHT WARNING	076799	1

## 6.6 Debarker Control Assembly

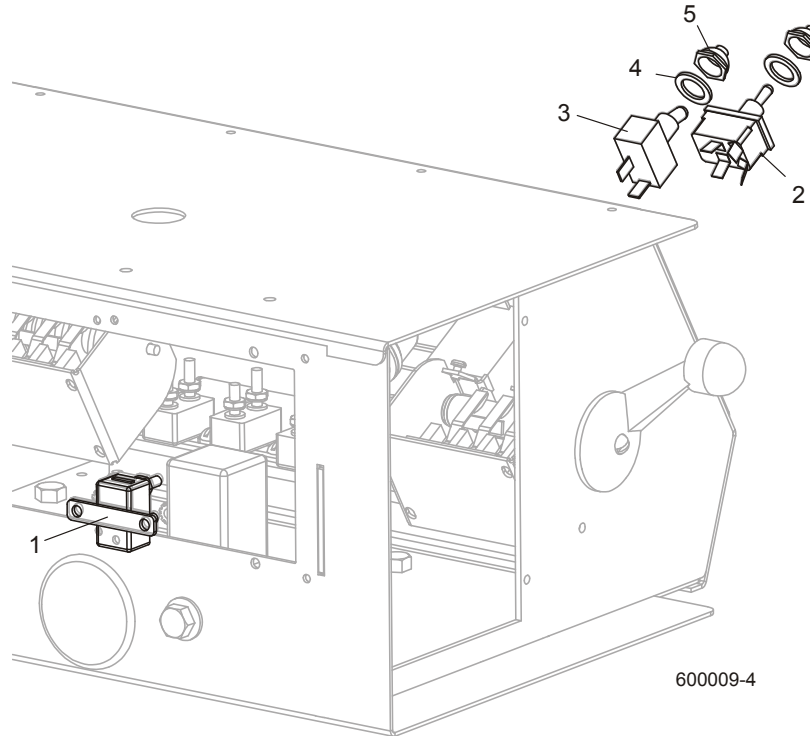

REF	DESCRIPTION (◆ Indicates Parts Available In Assemblies Only)	PART #	QTY.
	<b>CONTROL ASSEMBLY, DEBARKER AC LT60/70</b>	050912	1
	Harness Assembly, Debarker AC LT60/70 E25/E30	050428	1
1	Breaker, 15 Amp Manual Reset	E20430	1
2	Switch, DPDT Toggle Return Center Screw Terminal	024200	1
3	Switch, SPST Toggle Quick Connect	P03027	1
4	Washer, 1/2 x 3/4 x 1/16" Nylon	P05251-1	2
5	Boot, Toggle Switch	P02575	2

# INDEX

---

## A

alignment 3-1

---

## E

electrical information 5-1  
    component list 5-5  
    symbol diagram (non-remote) 5-1  
    symbol diagram (remote) 5-3  
    wiring diagrams (non-remote) 5-6  
    wiring diagrams (remote) 5-7  
    wiring diagrams (wireless) 5-9

---

## I

installation 2-1  
    control components (standard) 2-9  
    debarker 2-1

---

## M

maintenance 4-6

---

## O

operation 4-4  
    control overview 4-3  
    locking pin 4-1

---

## R

replacement parts 6-1  
    blade housing 6-8  
    blade motor & horn 6-7  
    control 6-9  
    frame 6-3  
    in/out motor 6-5  
    mechanical assembly 6-2

---

---

## S

safety 1-1  
    installation & maintenance 1-1  
    operation & towing 1-2

---

## T

troubleshooting 4-8

---