

LT70 AC MKIII Debarker Electric Mill Option

**Safety, Installation, Operation,
Maintenance & Parts Manual**

MKIII for LT70AC Sawmills rev. C.00
(Except LT70 Super Sawmills)*

Safety is our #1 concern!

Form #2089

Models Effected:

LT70 non-Remote
LT70 Remote Sawmills
LT70 AC Wireless Sawmills

*See Operator's and Parts Manuals for LT70
Super Debarker Information



**WARNING! Read and understand this
manual before using this machine.**

California

Proposition 65 Warning



WARNING: Breathing gas/diesel engine exhaust exposes you to chemicals known to the State of California to cause cancer and birth defects or other reproductive harm.

Always start and operate the engine in a well-ventilated area.
If in an enclosed area, vent the exhaust to the outside.
Do not modify or tamper with the exhaust system.
Do not idle the engine except as necessary.

For more information go to www.P65warnings.ca.gov.



WARNING: Drilling, sawing, sanding or machining wood products can expose you to wood dust, a substance known to the State of California to cause cancer. Avoid inhaling wood dust or use a dust mask or other safeguards for personal protection.

For more information go to www.P65Warnings.ca.gov/wood.

Active Patents assigned to Wood-Mizer, LLC

Wood-Mizer, LLC has received patents that protect our inventions which are a result of a dedication to research, innovation, development, and design. Learn more at: woodmizer.com/patents

©2024 Wood-Mizer LLC

Printed in the United States of America, all rights reserved. No part of this manual may be reproduced in any form by any photographic, electronic, mechanical or other means or used in any information storage and retrieval system without written permission from

Wood-Mizer, LLC
8180 West 10th Street
Indianapolis, Indiana 46214

SECTION 1 SAFETY

1.1 Safety Symbols 1-1
 1.2 Safety Instructions..... 1-1
 Observe ALL Safety Instructions..... 1-1
 1.3 Installation and Maintenance 1-1
 1.4 Operation and Towing 1-2

SECTION 2 DEBARKER INSTALLATION

2.1 Debarker Installation..... 2-1
 2.2 Harness Installation..... 2-3
 2.3 Control Component Installation..... 2-7

SECTION 3 ALIGNMENT

3.1 Debarker Alignment..... 3-1

SECTION 4 OPERATION AND MAINTENANCE

4.1 Debarker Travel Lock Pin..... 4-1
 4.2 Control Overview 4-2
 4.3 Operation 4-3
 4.4 Maintenance 4-4
 4.5 Debarker Troubleshooting 4-5

SECTION 5 ELECTRICAL INFORMATION

5.1 Debarker Electrical Symbol Diagram (Non-Remote)..... 5-1
 Low Voltage 5-1
 High Voltage 5-2
 5.2 Debarker Electrical Symbol Diagram (Remote)..... 5-3
 Low Voltage 5-3
 High Voltage 5-4
 5.3 Debarker Electrical Component List 5-5
 5.4 Debarker Electrical Wiring Diagram (non-Remote Sawmills)..... 5-6
 Low/High Voltage 5-6
 5.5 Debarker Electrical Wiring Diagram (Remote Sawmills)..... 5-7
 Low/High Voltage 5-7
 5.6 Debarker Electrical Wiring Diagram (AC Wireless Sawmills)..... 5-9
 Low/High Voltage 5-9

SECTION 6 REPLACEMENT PARTS

6.1 LT70 AC Mechanical Debarker..... 6-1
 6.2 Upper Pivot With Lock 6-1
 6.3 LT70 AC Debarker Cutter Head..... 6-1
 6.4 Mechanical Assembly (AC)..... 6-1
 6.5 In/Out Motor Drive Assembly 6-4
 6.6 Blade Motor Assembly (AC) 6-6
 6.7 Blade Housing Assembly..... 6-7
 6.8 Debarker Control Assembly..... 6-8

SECTION 1 SAFETY

1.1 Safety Symbols

The following symbols and signal words call your attention to instructions concerning your personal safety. Be sure to observe and follow these instructions.

 **DANGER!** indicates an imminently hazardous situation which, if not avoided, will result in serious injury or death.

 **WARNING!** suggests a potentially hazardous situation which, if not avoided, could result in serious injury or death.

 **CAUTION!** refers to potentially hazardous situations which, if not avoided, may result in minor or moderate injury or damage to equipment.

NOTICE indicates vital information.

1.2 Safety Instructions

OWNER/OPERATOR'S RESPONSIBILITY

The procedures listed in this manual may not include all ANSI, OSHA, or locally required safety procedures. **It is the owner/operator's responsibility and not Wood-Mizer LLC to ensure all operators are properly trained and informed of all safety protocols.** Owner/Operators are responsible for following all safety procedures when operating and performing maintenance to the equipment.

Observe ALL Safety Instructions

NOTICE Read the entire Operator's Manual before operating this equipment.

Note all safety warnings throughout this manual and those posted on the machine.

Be able to access this manual at all times while operating this equipment.

Read additional manufacturer's manuals and observe their applicable safety instructions.

Only persons who have read and understood the entire operator's manual should operate this equipment.

This equipment is not intended for use by or around children.

It is the owner/operator's responsibility to comply with all applicable federal, state, and local laws, rules, and regulations regarding the ownership, operation, and transporting your equipment.



Operators should become thoroughly familiar with and comply with these applicable laws for operating and transporting equipment.

 **WARNING!** Clean sawdust from all guards, vents, control boxes, or any area where sawdust may gather **after every shift**. Failure to do so may result in fire, causing death or serious injury.

1.3 Installation and Maintenance

 **DANGER!** On electric mills, hazardous voltage inside the disconnect box, starter box, and at the electric motor can cause shock, burns, or death. Disconnect and lock out power supply before performing debarker installation! Follow all applicable electrical codes.

DANGER! Make sure all electrical installation, service and/or maintenance work is performed by a qualified electrician and is in accordance with applicable electrical codes.

DANGER! Before performing any service to this equipment, turn the key to the OFF position, remove the key, and disconnect the sawmill battery ground terminal.

 **WARNING!** Before replacing the debarker blade, move the sawmill blade guide arm in front of the sawmill blade to cover the blade teeth.

1.4 Operation and Towing



DANGER! Make sure all guards and covers are in place and secured before operating the debarker option. Failure to do so may result in serious injury.

DANGER! Keep all persons out of the path of moving equipment when operating the debarker. Failure to do so will result in serious injury.

DANGER! Always remove the key from the control panel before preparing the debarker for towing. Failure to do so may result in serious injury.



WARNING! Debarker is ON when warning light is on. DO NOT disconnect the warning light. Doing so may result in serious injury.

WARNING! If the debarker continues to run with the key switch in the OFF position, remove the negative battery terminal from the battery post.

DO NOT continue to operate the mill if the main key switch does not control debarker operation. Doing so could result in serious injury. Call Wood-Mizer customer service for more information.

SECTION 2 DEBARKER INSTALLATION



DANGER! On electric mills, hazardous voltage inside the disconnect box, starter box, and at the electric motor can cause shock, burns, or death. Disconnect and lock out power supply before performing debarker installation! Follow all applicable electrical codes.

DANGER! Before performing any service to this equipment, turn the key to the OFF (0) position, remove the key, and disconnect the sawmill battery ground terminal. Failure to do so will result in serious injury or death.



CAUTION! Due to various design changes and past retrofits and options, you should very carefully look your mill over to determine Debarker compatibility before beginning Debarker installation.

2.1 Debarker Installation



DANGER! Always disengage the blade and shut off the sawmill engine before installing the debarker. Failure to do so will result in serious injury.

IMPORTANT! Sawmills are equipped with pre-drilled Debarker mounting holes. **Verify hole locations before beginning Debarker installation. Proper hole location is imperative for safe and effective Debarker operation.**

The debarker wiring is pre-routed and secured at the debarker mounting location with a guard.

1. Remove the guard and route the wiring through the grommet in the saw head.
2. Note the location of the two debarker mounting holes.
3. Assemble the debarker to the sawmill saw head. Align the mounting block holes and the two debarker mounting holes in the saw head.
4. Use the provided 1/2-13 x 4" hex head bolts and 1/2" split lock washers to secure in place.

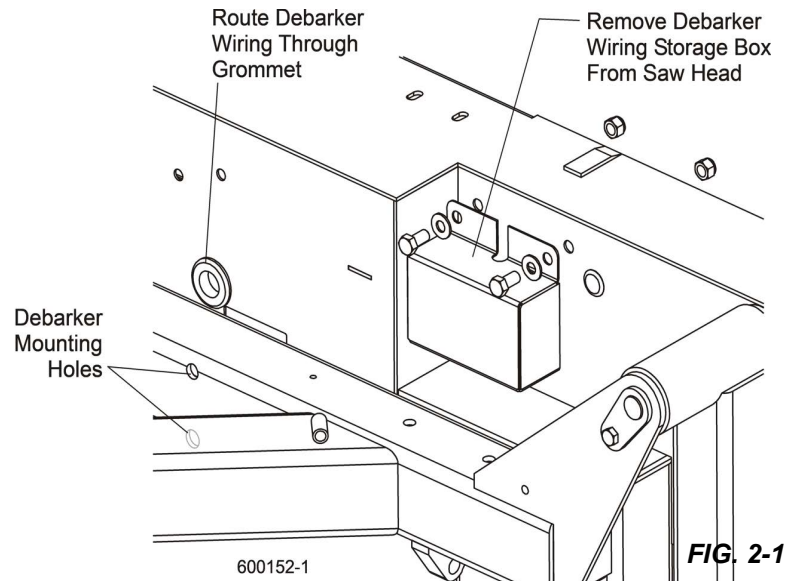

5. Make sure the debarker is square to the saw head before tightening.
6. Assemble the debarker cutting head to the mount plate on the frame.
7. Use the four provided 5/16-18 x 3/4" bolts and 5/16" split lock washers to mount the cutting head to the debarker frame.
8. Use the lower set of four holes in the head mounting plate.

The upper set of holes are provided in the event the cutting head needs to be adjusted further down than the slotted motor mount holes will allow.

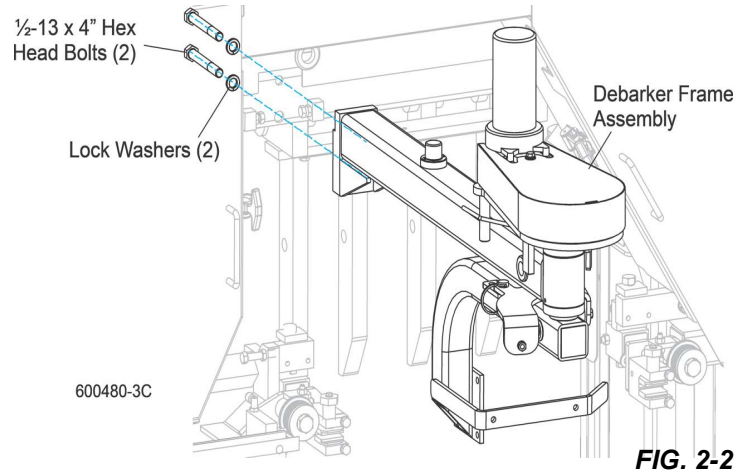

FIG. 2-2

9. Install the blade guard bracket and flexible debris guard to the debarker head with two 1/4" flat washers, lock washers, and 1/4-20 x 1" hex head bolts.
10. Be sure the bottom of the debris guard is even with the bottom of the debarker blade.

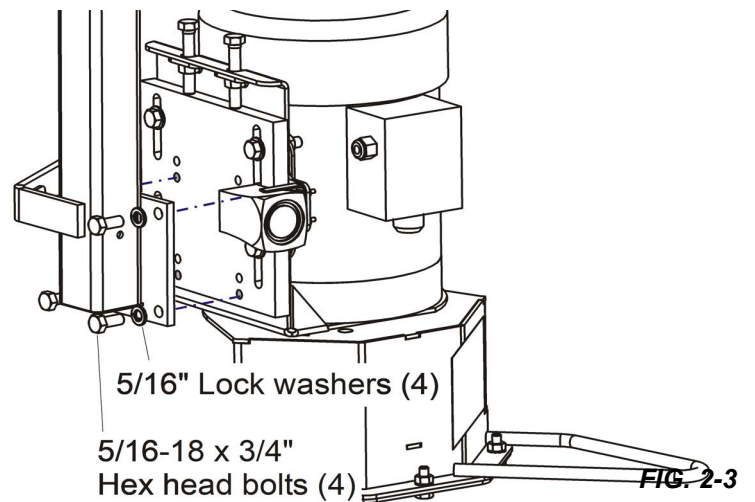
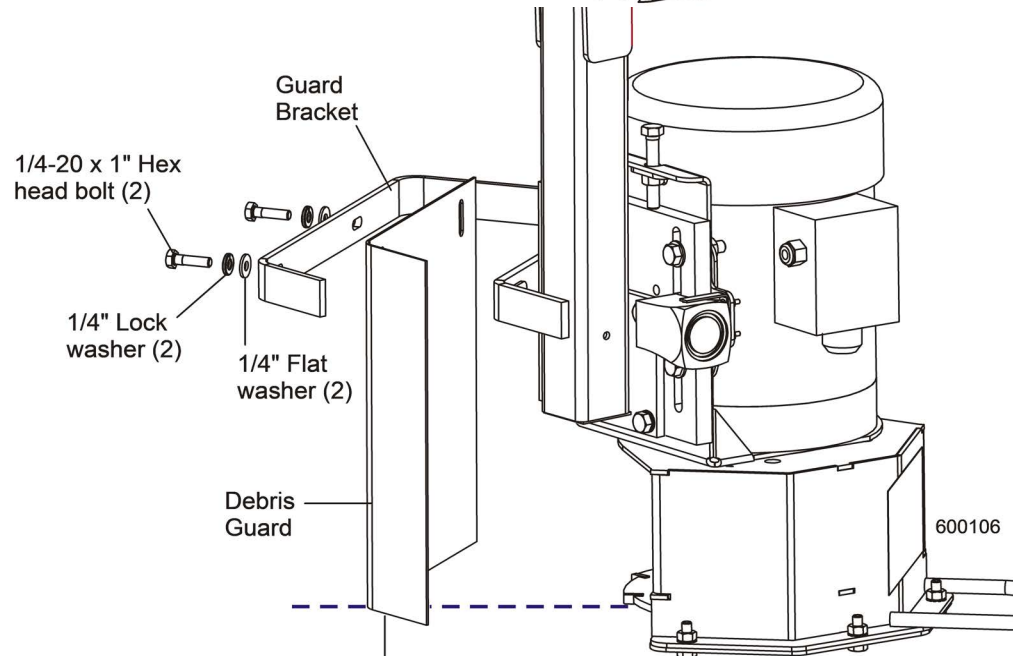

FIG. 2-3

FOR REPLACING OLD DEBARKER FOR LT70 SAWMILLS WITH THE NEW ONE WITH MOTOR PLEASE SEE ONLINE INSTRUCTION SHEET.



Adjust bottom of debris guard even with bottom of debarker blade

FIG. 2-4

2.2 Harness Installation



DANGER! On electric mills, hazardous voltage inside the disconnect box, starter box, and at the electric motor can cause shock, burns, or death. Disconnect and lock out power! Follow all applicable electrical codes.

DANGER! Before performing any service to this equipment, turn the key to the OFF (0) position, remove the key, and disconnect the sawmill battery ground terminal. Failure to do so will result in serious injury or death.

NOTICE Avoid pinch and pivot points, unnecessary wire bending and open spaces where the wire could get caught by a log, etc. If you have any questions, call Wood-Mizer customer service.

1. Route the harnesses through the saw head frame hole as shown.
2. Continue routing the long blade motor wire harness (large wires/ring terminals) inside the debarker frame through the three holes with grommets.

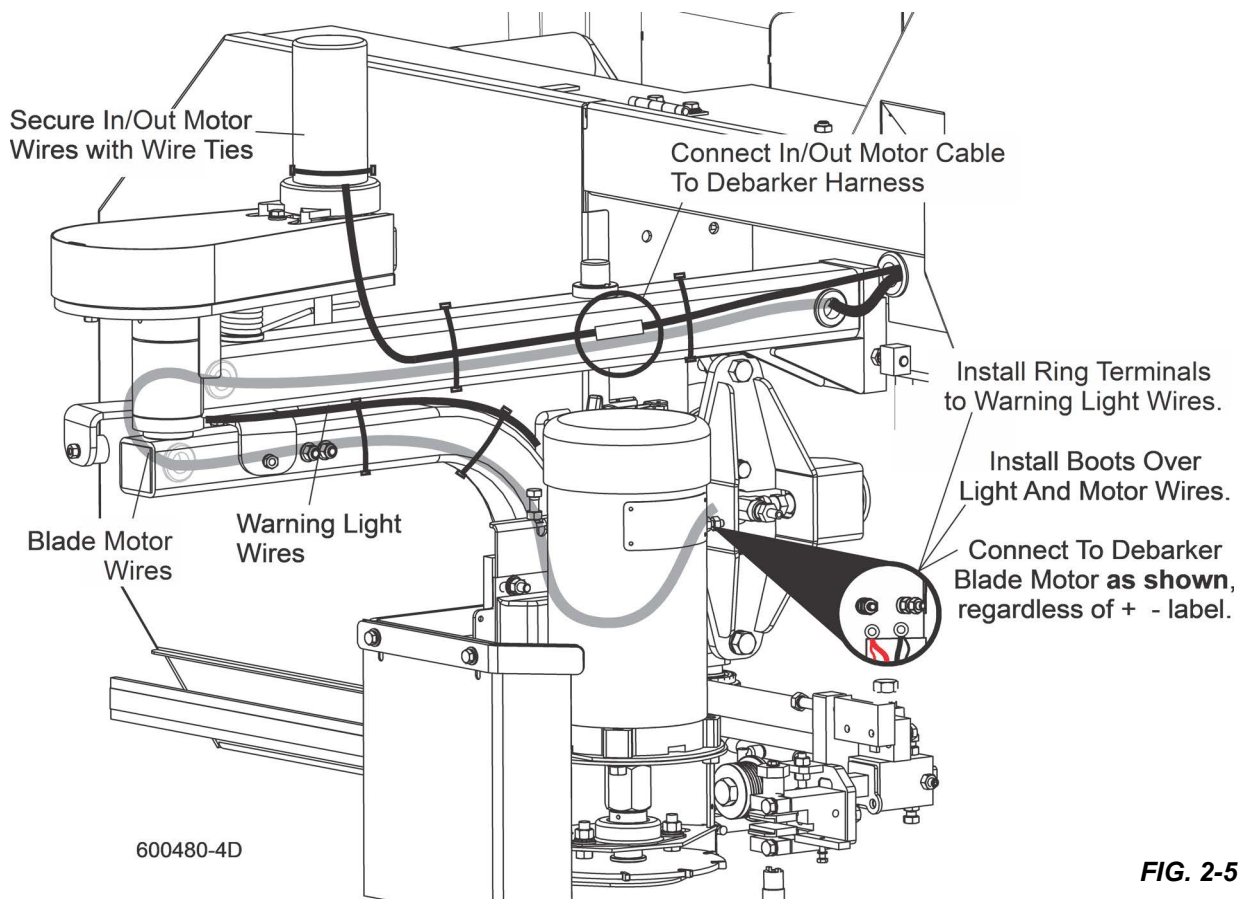

FIG. 2-5

3. Cut the conduit of the in/out motor wire harness to expose the quick connect terminals.
4. Remove the rubber cap from the in/out motor and install the removed conduit around the in/out motor wires.
5. Route the wires down the side of the in/out motor to the quick connects.
6. Be sure to leave slack in the harness to avoid kinking and bending as the debarker moves in and out.
7. Replace the motor cap and secure the harness to the in/out motor by connecting two wire ties together and wrapping around the motor.
8. Connect the in/out motor wire harness to the in/out motor saw head harness.
9. Secure the harness to the blade motor frame with wire ties.

10. Route the warning light harness on top of the blade motor pivot arm to the debarker blade motor.
11. Secure the warning light wires to the pivot arm with wire ties as shown above.

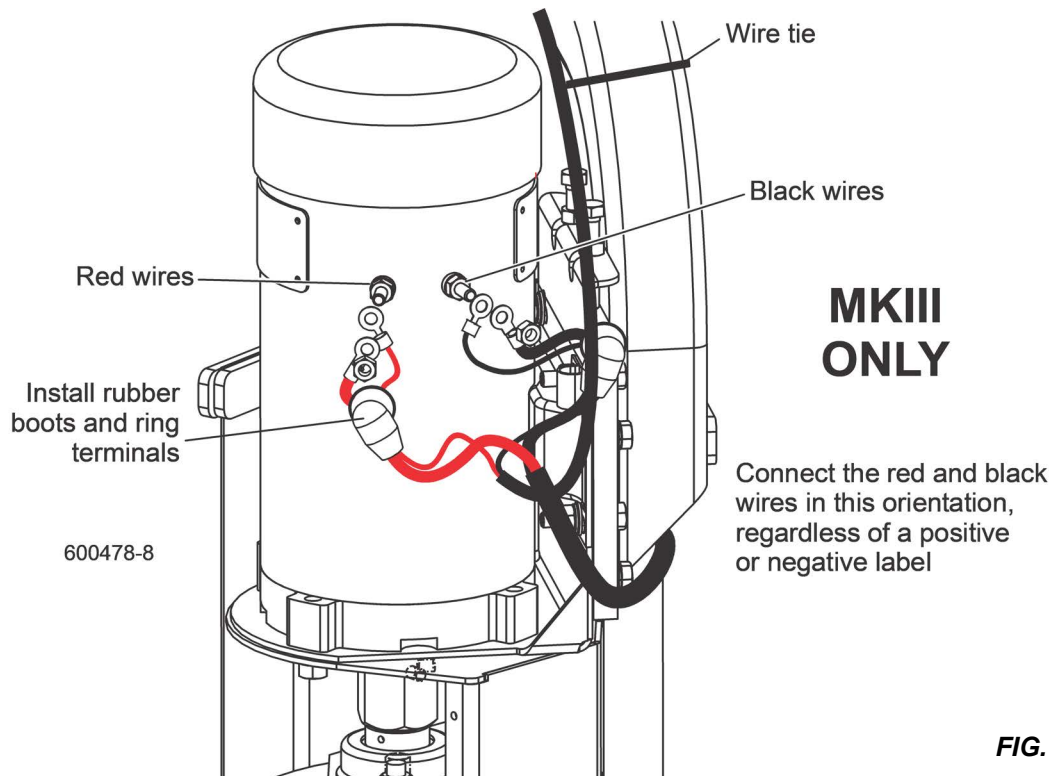

FIG. 2-6

12. Remove the top nuts from each of the motor terminals.

NOTICE Make sure that the ring terminals do not touch the motor body.

13. Connect both black wires to the **right motor terminal** and replace the terminal nut to secure the wires. **Reference figure 2-6.**

NOTICE Make sure that the ring terminals do not touch the motor body.

14. Slide the rubber boots over the motor terminal posts to protect the connections.

1. Install the supplied wire harness to the debarker motor junction box.
2. Insert the end of the harness with bare wire ends through the hole in the bottom of the debarker motor junction box and secure with the harness connector.
3. Leave approximately 1/2" of harness conduit past the connector.

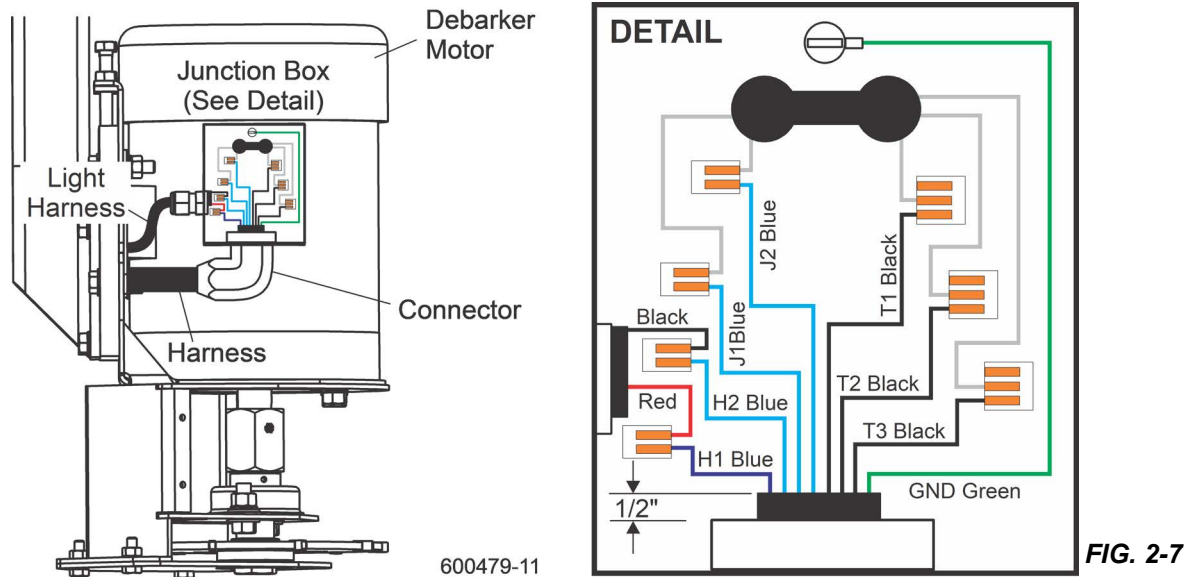

4. Connect the harness wires to the corresponding debarker motor wires, matching the wire labels as shown.
5. Connect the green GND wire to the ground terminal in the motor junction box.
6. Route the harness through the hole in the saw head.
7. Locate the two-wire harness supplied with the sawmill for the debarker in/out motor. This harness is bundled with other harnesses underneath the sawmill motor.
8. Route the two-wire harness through the hole in the saw head, toward the debarker.
9. Connect the harness to the debarker in/out motor connector.

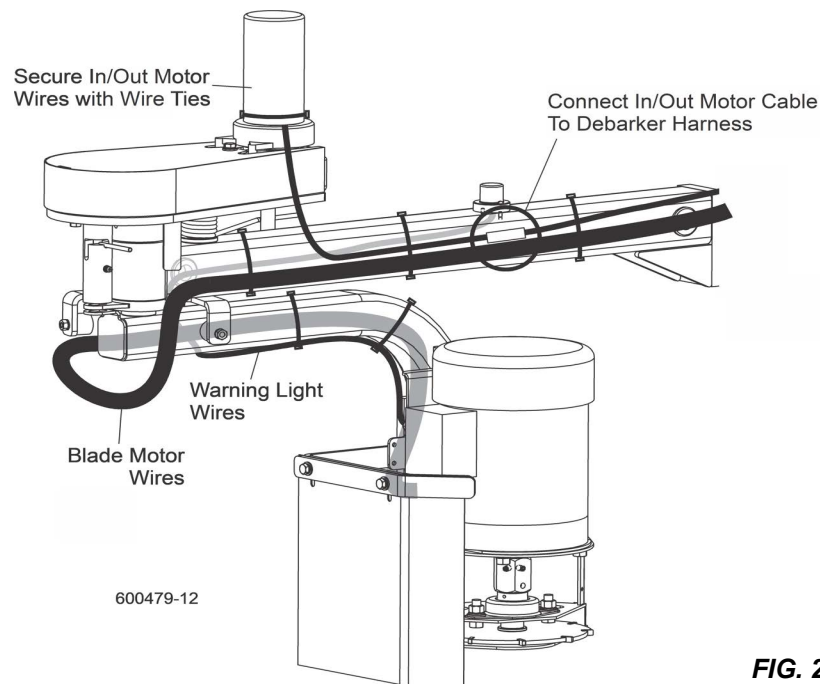

10. Continue routing the large harness from the debarker motor under the sawmill motor, toward the electrical control cabinet.
11. Remove the plug from the hole in the bottom of the cabinet and push the harness up into the box.

12. Secure the harness to the cabinet hole with the provided connector, leaving approximately 1/2" of harness conduit past the connector.
 13. Use the provided wire tie to secure the harness to existing harnesses under the sawmill motor.
 14. In the control cabinet, remove the wireway covers and route the harness wires to the appropriate components.
- Only wires listed above are shown.

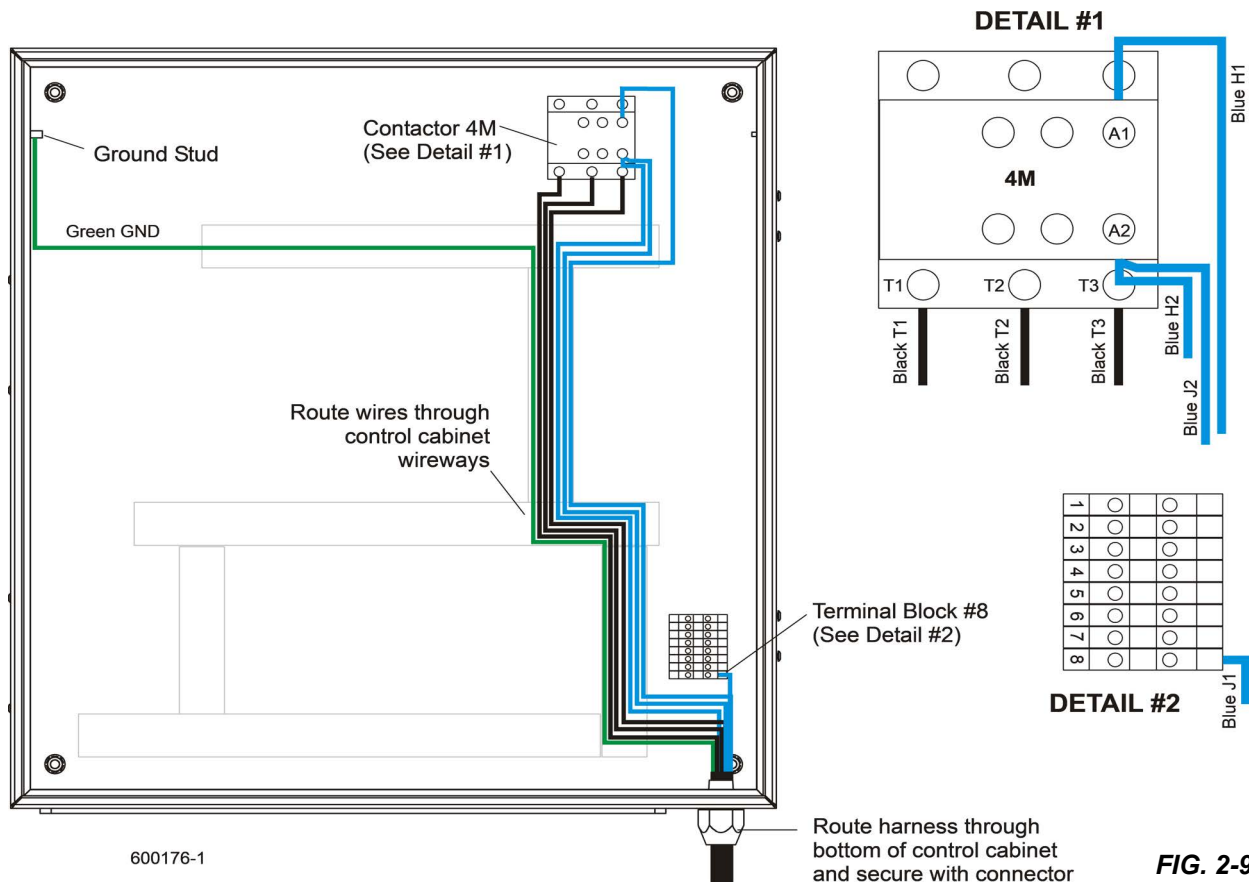

FIG. 2-9

15. Connect the black T1, T2, and T3 wires to the corresponding terminals on the contactor labeled 4M at the top-right corner of the cabinet.
16. Connect the green GND wire to the grounding terminal at the top-left of the control cabinet.
17. Connect the blue H1 wire to the A1 terminal of the 4M contactor.
18. Connect the blue J2 and H2 wires to the A2 terminal of the 4M contactor.
19. Connect the blue J1 wire to empty side of terminal block #8. Replace the wireway covers.

2.3 Control Component Installation



DANGER! On electric mills, hazardous voltage inside the disconnect box, starter box, and at the electric motor can cause shock, burns, or death. Disconnect and lock out power! Follow all applicable electrical codes.

DANGER! Before performing any service to this equipment, turn the key to the OFF (0) position, remove the key, and disconnect the sawmill battery ground terminal. Failure to do so will result in serious injury or death.

See [SECTION 4](#) for the appropriate wiring diagram to aid in installation.

1. Remove the side, front and rear panels (leave wire connections) from the control box.
2. Remove the two small bolts and nuts from the back of the control box.
3. Install the provided 15 amp breaker to the two small holes in the back of the control box (position the breaker so the reset tab is near the rear opening of the control box).
4. Use the existing screws and nuts (removed earlier) to secure in place.
5. Using the back side of the front panel for a guideline, cut out holes in the front panel lexan decal for the debarker switches.
6. Install the provided toggle switches, 1/16" nylon washers, and rubber boots in place as shown.

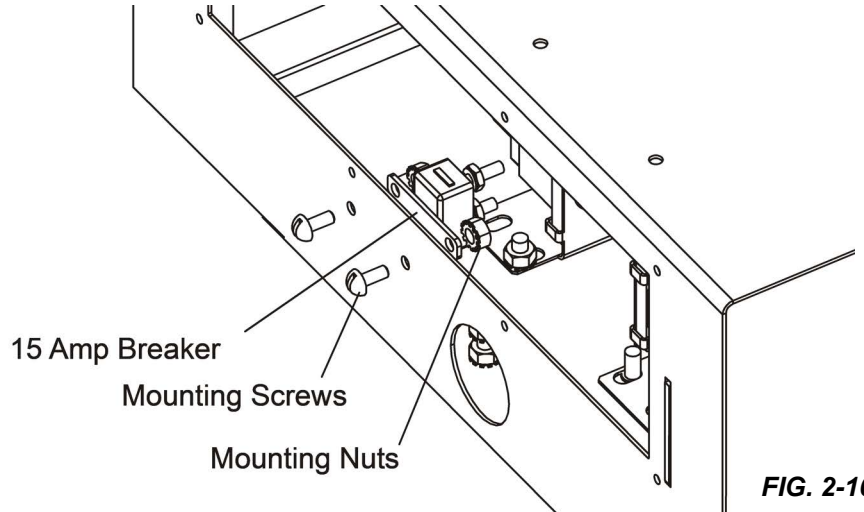
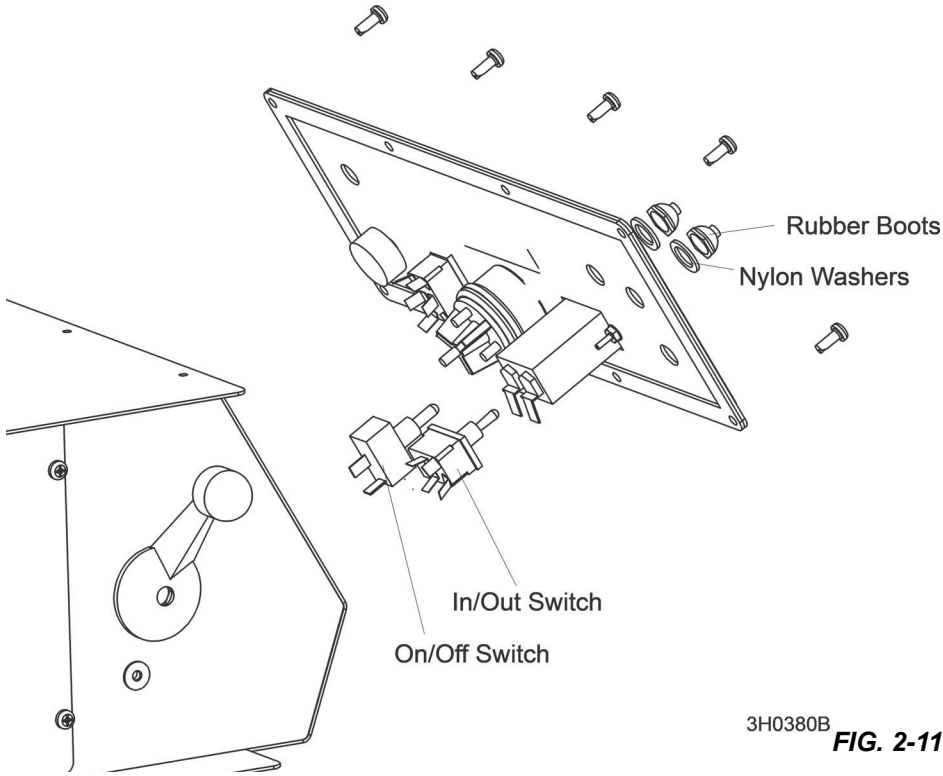

FIG. 2-10



3H0380B **FIG. 2-11**

7. Connect the red #205 wire from the 15 amp breaker to the ACC post on the key switch.
8. Make sure the red #206 wire from the 15 amp breaker to the debarker in/out switch is connected.
9. Connect the red #208 wire from the debarker on/off switch to the DBKR terminal on the LED board.

NOTE: If the control box is not equipped with the LED board, remove the red #208 wire from the debarker on/off switch.

10. Connect the red #200 wire from the on/off switch to terminal #3 of the existing relay socket in the control box.

Box housing removed for clarity. Only wires referred to above are shown.

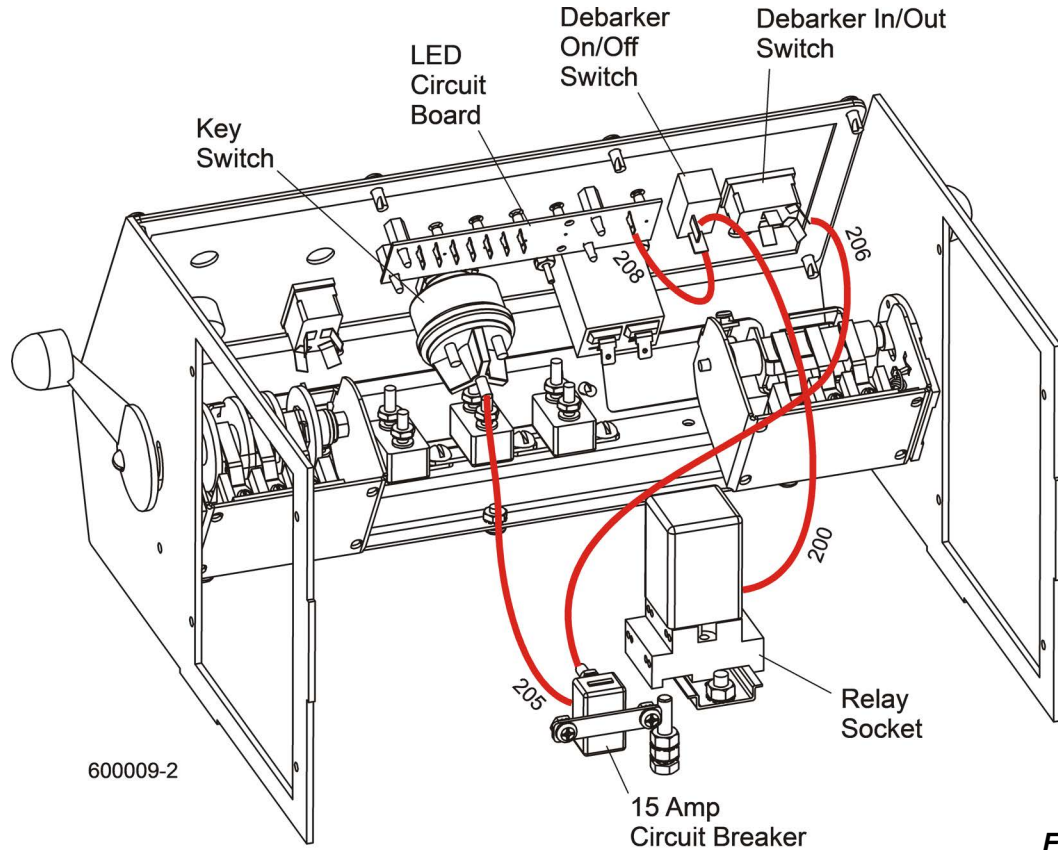

FIG. 2-12

11. Connect the black #207 wire from the debarker in/out switch to the rear ground stud.
12. Locate the bundle of wires on the floor of the sawmill control box.
13. Make sure the debarker in/out switch is oriented horizontally as shown.
14. Connect the small red #21 wire to the debarker in/out switch bottom left terminal.
15. Connect the small black #22 wire to the debarker in/out switch top left terminal.
16. Connect wire #33 (blue on non-remotes, red on remotes) to the bottom debarker on/off switch terminal.

Box housing removed for clarity. Only wires referred to above are shown.

17. Reinstall the front and rear panels, side panel, and control box top cover to the control box.

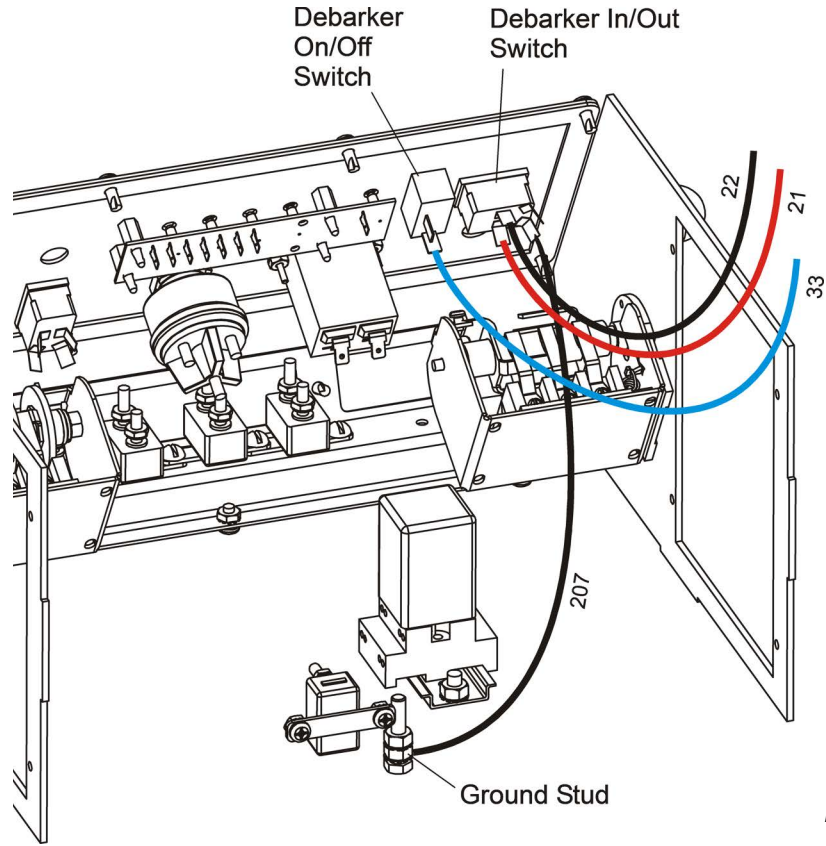

FIG. 2-13

SECTION 3 ALIGNMENT

3.1 Debarker Alignment



DANGER! Before performing any service to this equipment, turn the key to the OFF (0) position and remove the key. Failure to do so will result in serious injury or death.

The debarker blade should be aligned to the sawmill blade to insure proper operation. The debarker blade should be parallel with and aligned vertically with the sawmill blade.

1. Turn the key to ACC (3) and use the debarker in/out switch to move the debarker all the way in.
2. Turn the key to OFF (0) and remove the key to prevent the debarker from being turned on while performing alignment procedures.
3. Check the squareness of the debarker with the sawmill blade.
4. Adjust the debarker mounts if necessary until the debarker is square with the sawmill blade.
5. Loosen the bottom debarker mounting bolt and loosen the jam nuts on the adjustment bolts.
6. Turn the adjustment bolts as necessary until the debarker is square with the sawmill blade.
7. Retighten the jam nuts and bottom debarker mounting bolt.
8. Clip the blade guide alignment tool to the sawmill blade.
9. Make sure the tool lies flat on the blade and does not contact a tooth that could cause it to angle.

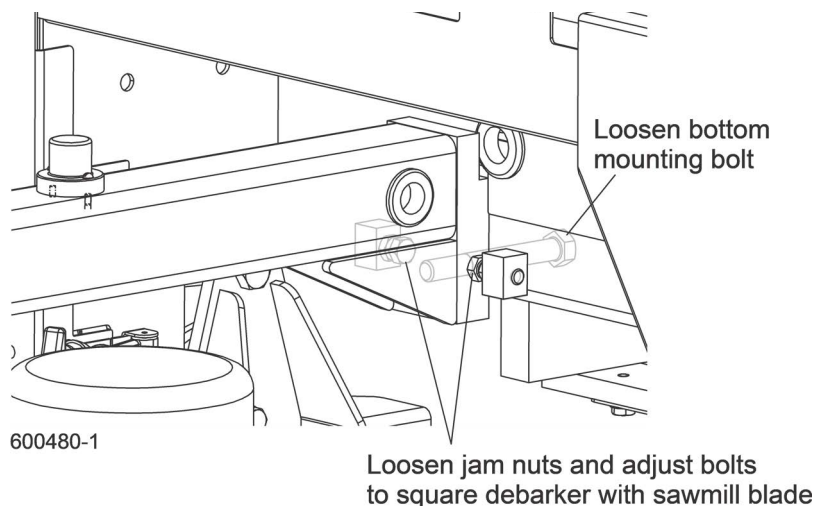
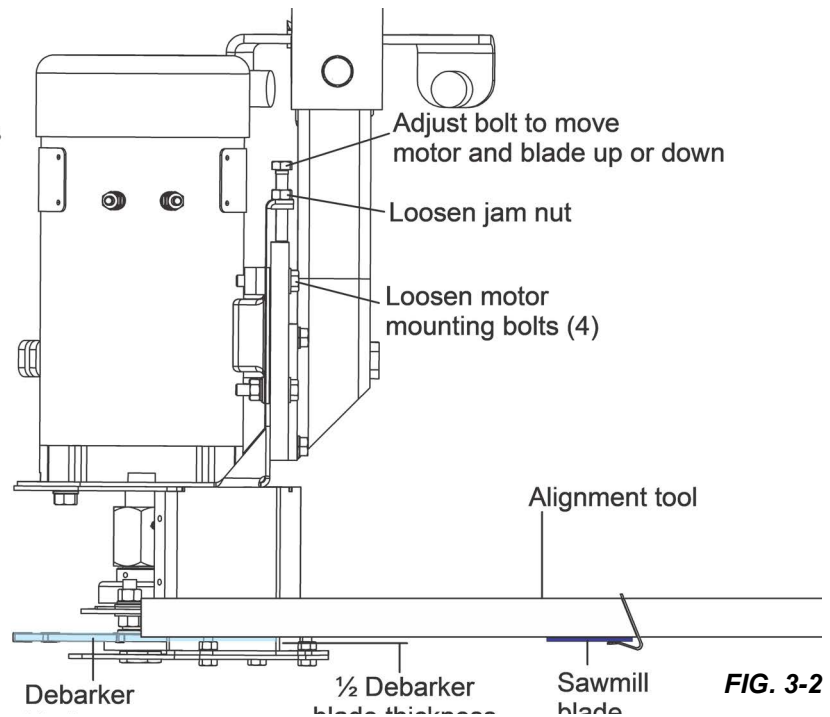

FIG. 3-1

10. Check the height of the debarker blade against the alignment tool.
11. The bottom edge of the tool should align with the center of the debarker blade.
12. Insert the key and use the debarker in/out switch to move the debarker all the way out.
13. Turn the key to OFF (0) and remove the key.
14. Move the blade guide alignment tool on the sawmill blade and check the position of the debarker blade against the tool.
15. If the debarker blade is not centered with the tool, readjust the debarker mounting bolts to adjust the debarker assembly parallel to the blade.



SECTION 4 OPERATION AND MAINTENANCE

4.1 Debarker Travel Lock Pin

The debarker is equipped with a travel lock pin. Insert the lock pin to lock the debarker in place when towing the sawmill. Remove the lock pin to unlock the debarker while the debarking is required during sawing.

Before operating the debarker, make sure the lock pin is secured in its travel position. Turn the key switch to OFF (0) and remove the key. Pull the debarker out to relieve pressure on the lock pin. Remove the lock pin.

Before towing the sawmill, lock the debarker in the travel position. Turn the key switch to ACC (3) and use the debarker in/out switch to move the debarker all the way in. Turn the key to OFF (0) and remove the key. Push the debarker in until the travel position holes align. Insert the lock pin.

To move the debarker out of the way during sawing, turn the key switch to ACC (3) and use the debarker in/out switch to move the debarker all the way out.

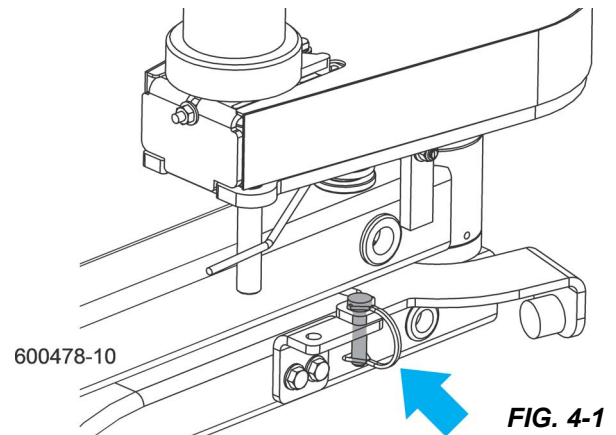

4.2 Control Overview

The Debarker Option allows you to remove bark from logs ahead of the bandsaw blade. This prevents the bandsaw blade from contacting dirt, sand, or other debris in the bark that can dull the blade.

The debarker control includes two toggle switches and an indicator light.

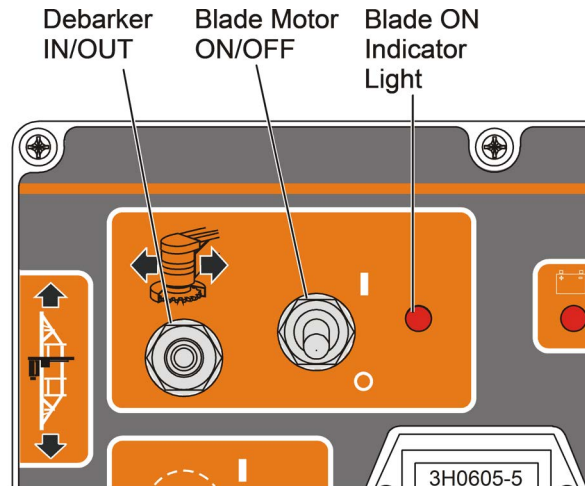

FIG. 4-2

- The Debarker IN/OUT toggle switch controls the debarker in/out motor to move the debarker saw head toward or away from the log. The sawmill key switch must be on before the in/out function can be performed. **NOTE:** The distance between the debarker blade and the side support with the saw head all the way in is 6" (150mm) for the sawmill equipped with the standard head and 12" (300mm) for the sawmill equipped with the wide head.
- The Blade Motor ON/OFF toggle switch turns the blade motor on to start the debarker blade. The sawmill key switch must be on and the sawmill power feed drum switch must be activated in the forward direction before the blade motor can be turned on.
- The Blade ON indicator light comes on whenever the debarker blade motor is on.

4.3 Operation



DANGER! Make sure all guards and covers are in place and secured before operating the debarker option. Failure to do so may result in serious injury.

DANGER! Keep all persons out of the path of moving equipment when operating the debarker. Failure to do so will result in serious injury.

1. Remove the blade motor cover before operating the debarker.
2. Make sure the warning light is on when the debarker is turned on.



WARNING! Debarker is ON when warning light is on. **DO NOT** disconnect the warning light. Doing so may result in serious injury.

3. Use the in/out switch on the control box to pivot the debarker all the way out.
4. Move the sawmill carriage forward and pivot the debarker in until the front fence engages with the end/side of the log.
5. Turn the debarker on/off switch to ON (1).
6. Proceed with cutting. The actuator will keep the debarker against the side of the log. Depending on log shape, you may have to pivot the debarker in and out for smooth cutting.

NOTE: The debarker can continuously remove up to approximately 1" of material from the log; no motor cool down time is required. Slower feed rates may be required for optimal debarker operation.

7. Once the carriage is past the end of the log, pivot the debarker away from the log. Return the carriage.

IMPORTANT! Should the carriage be returned before the debarker has been pivoted out of the way of the log, the debarker is designed to pivot upwards. If this happens, continue to **SLOWLY** return the carriage; or stop, pivot the debarker out and then return the carriage. **DO NOT** move the carriage forward while the debarker is contacting the log without the blade spinning.

8. When done sawing and ready to store or transport the sawmill, replace the debarker blade motor cover. Place the debarker in its travel position before towing the sawmill ().

4.4 Maintenance



DANGER! Before performing any service to this equipment, turn the key to the OFF (0) position and remove the key. Failure to do so will result in serious injury or death.

1. Lubricate the pivot joint with a NLGI #2 grade lithium grease every 40 hours of operation.
2. Periodically check the flexible guard.
3. Adjust the guard up or down so the bottom is even with the bottom of the debarker blade.
4. Replace the guard as needed.
5. Periodically check the debarker blade.
6. Align or replace as needed.



WARNING! Before replacing the debarker blade, move the sawmill blade guide arm in front of the sawmill blade to cover the blade teeth. Failure to do so may result in serious injury or death.

1. To replace the debarker blade,
2. remove the lower blade guard plate.
3. Place one wrench on the blade arbor, above the blade bearing.
4. Place the other wrench on the lower bolt and rotate clockwise (bolt has left-hand threads).
5. Remove the bolt and washer. Remove the blade and spacer.
6. Reinstall the spacer with the new blade.
7. Reinstall the bolt and washer and turn counterclockwise to tighten to 35 foot-pounds (± 5).
8. Reinstall the blade guard plate.



CAUTION! Tighten the blade bolt manually. Using power-assisted tools may result in over-torquing and damage to the bolt.

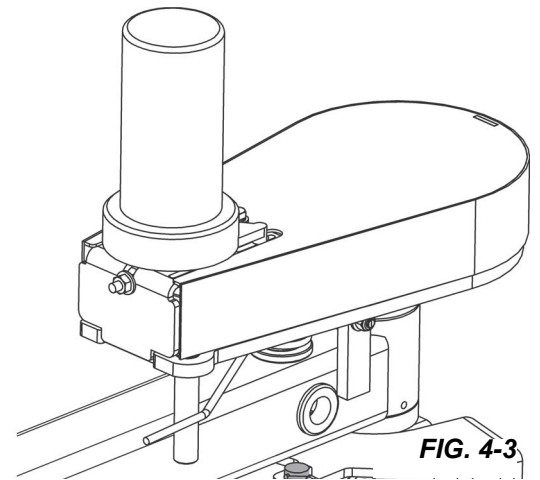

4.5 Debarker Troubleshooting



DANGER! Before performing any service to this equipment, turn the key to the OFF (0) position, remove the key, and disconnect the sawmill battery ground terminal. Failure to do so will result in serious injury or death.

PROBLEM	CAUSE	SOLUTION
70 amp circuit breaker tripping	Wood or bark jammed in blade guard	Turn key to OFF position, remove key. Remove wood or bark from blade guard
	Pivot pin is binding.	Inspect for bind by moving debarker head to full in position. Turn key to OFF position, remove key. Pull arm to full out position by hand. If available, use a weight scale to pull arm to full out position. Should not have more than 12 pounds of resistance to pull out. Ensure pivot pin has been greased properly. Check pivot clamps for correct installation. Loosen pivot clamp bolts slightly, check for reduced binding
	Ring terminal of red wire touching debarker motor housing at motor	Move terminal away from motor housing. Reset circuit breaker and retest.
Light comes on, but debarker motor and warning light do not operate	Circuit breaker weak from repeated tripping.	Replace circuit breaker
	Circuit breaker tripped	Reset circuit breaker.
Debarker shuts off, but the circuit breaker is not tripped.	Bad ignition wire connection	Check ignition wire connection outside and inside of debarker control box.
	Intermittent key switch	Replace key switch
	Other loose wiring connection	Check wiring connections inside control box.
Debarker will not shut off.	Solenoid is stuck closed.	Replace solenoid.
IN/OUT Motor does not move IN or OUT	Drive belt too loose	Tighten enough to allow movement. DO NOT OVER-TIGHTEN.
	Switch not working properly	Check wiring to switch for loose connections. If wiring looks OK, replace switch.

SECTION 5 ELECTRICAL INFORMATION

5.1 Debarker Electrical Symbol Diagram (Non-Remote)

Low Voltage

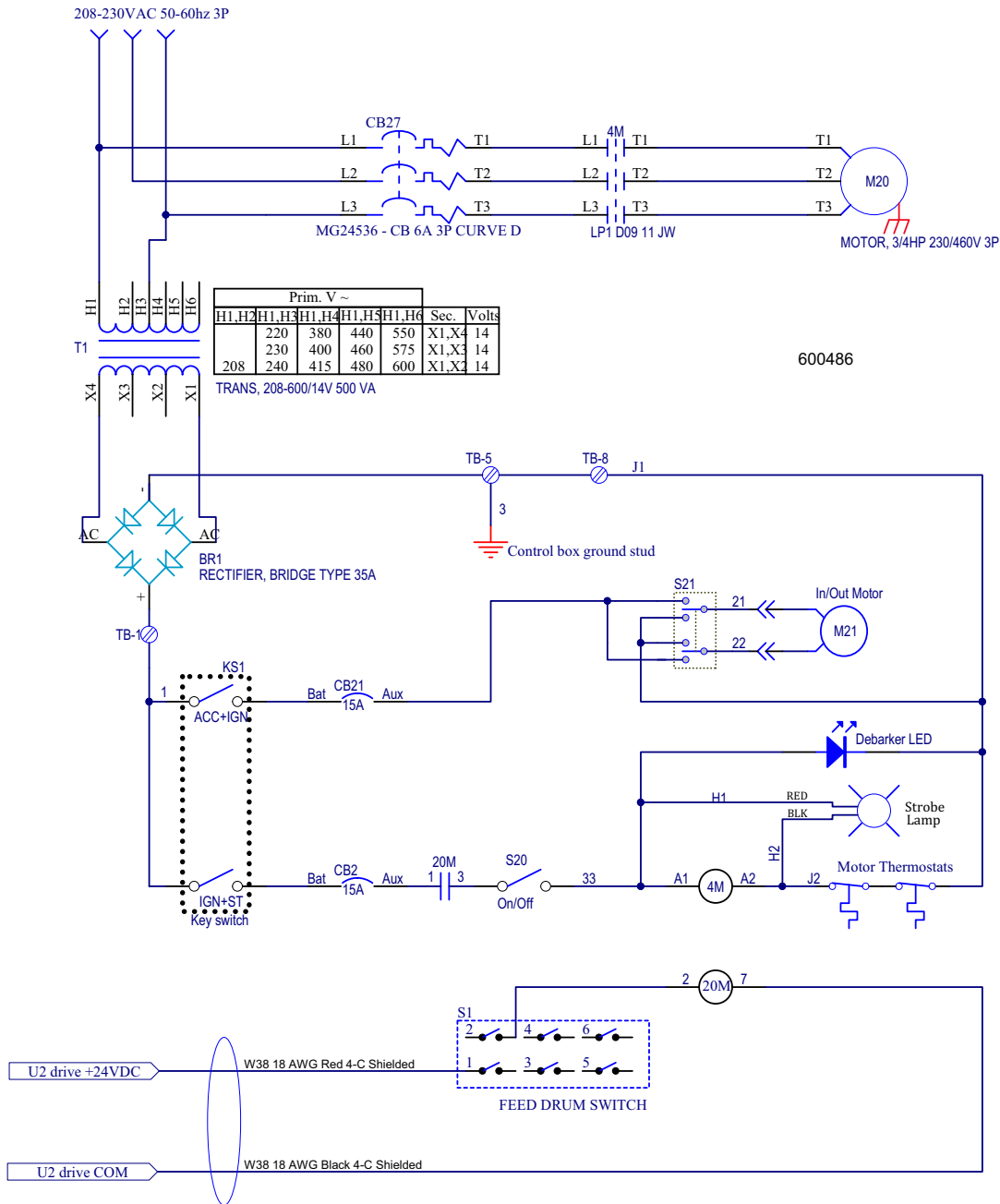

FIG. 5-1

High Voltage

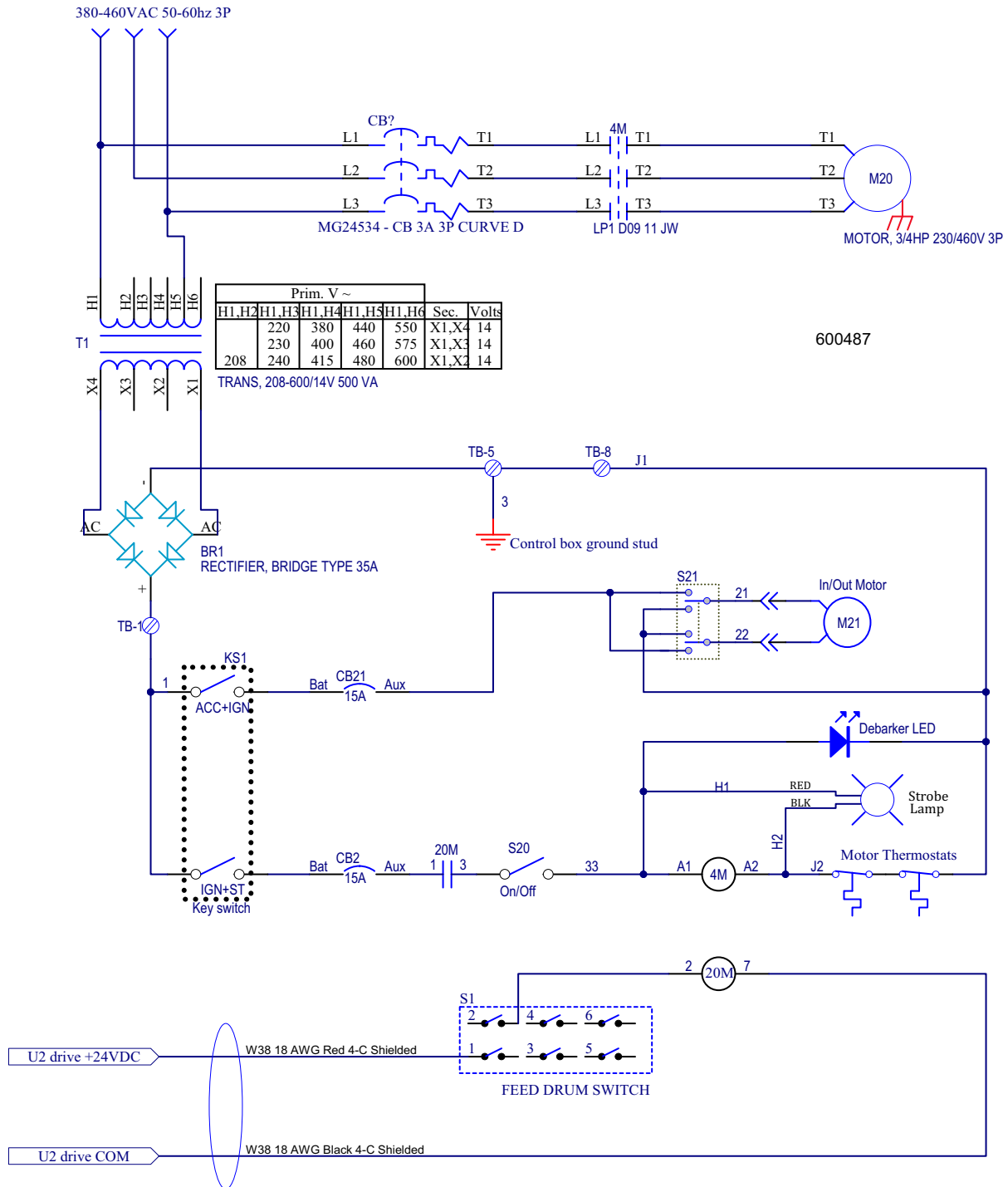

FIG. 5-2

5.2 Debarker Electrical Symbol Diagram (Remote)

Low Voltage

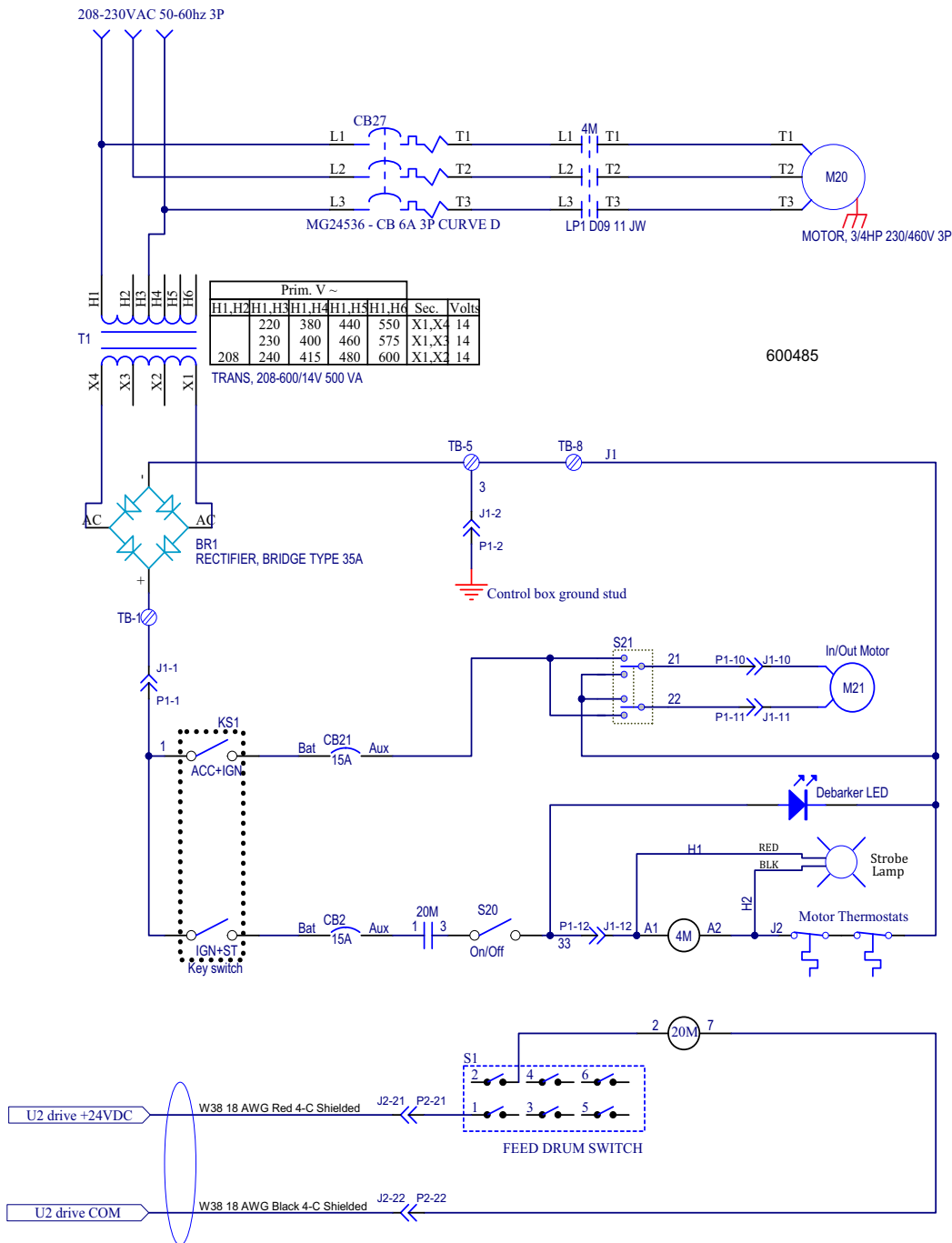

FIG. 5-3

High Voltage

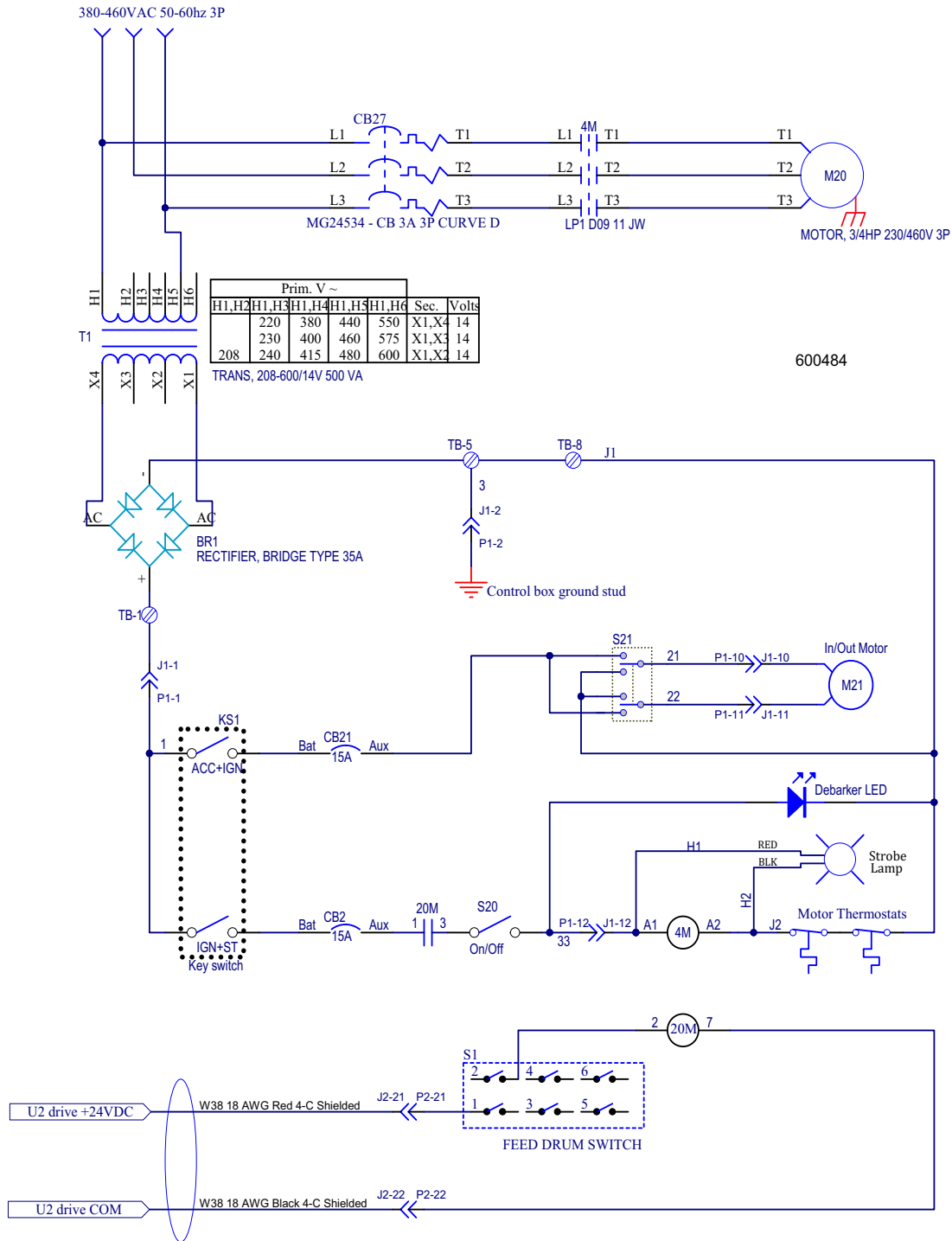

FIG. 5-4

5.3 Debarker Electrical Component List

ID	Wood-Mizer Part No.	Description
CB21	E20430	Breaker, 15 Amp
L1	073555	Light Assembly, Debarker ON Warning Strobe
M20	050292	Motor, 3/4HP 230/460 3P 1725RPM
M21	074826	Gearmotor Assembly, LT70 Debarker In/Out
S20	P03027	Switch, Toggle
S21	024200	Switch, DPDT Toggle

5.4 Debarker Electrical Wiring Diagram (non-Remote Sawmills)

Low/High Voltage

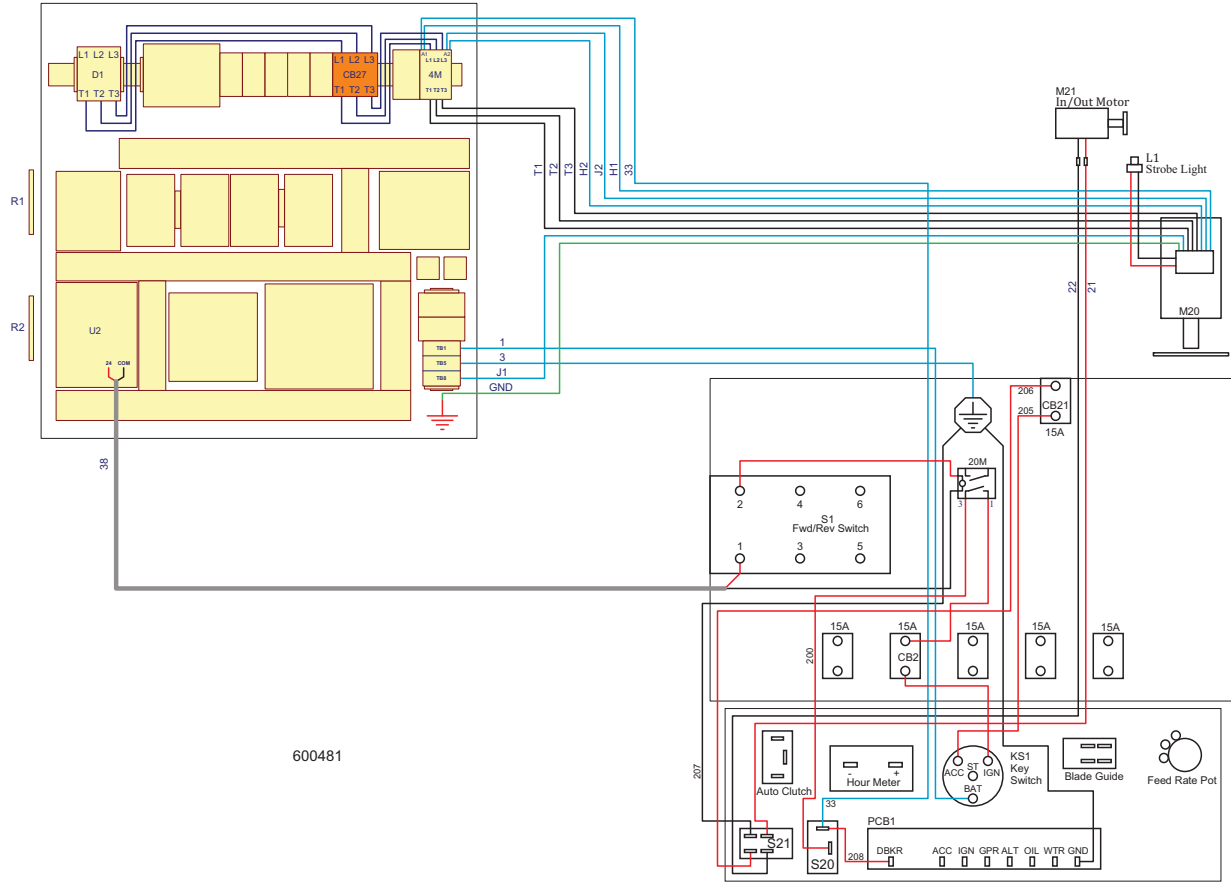

FIG. 5-5

5.5 Debarker Electrical Wiring Diagram (Remote Sawmills)

Low/High Voltage

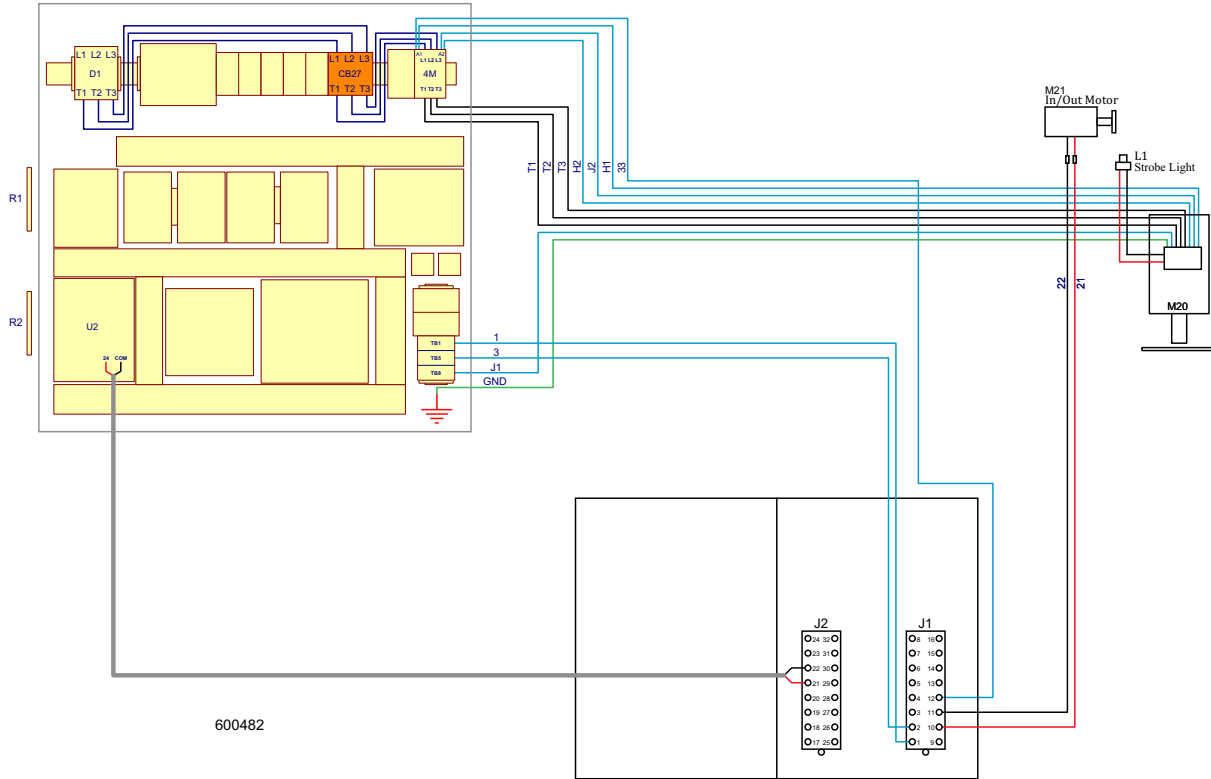

FIG. 5-6 (PAGE 1 OF 2)

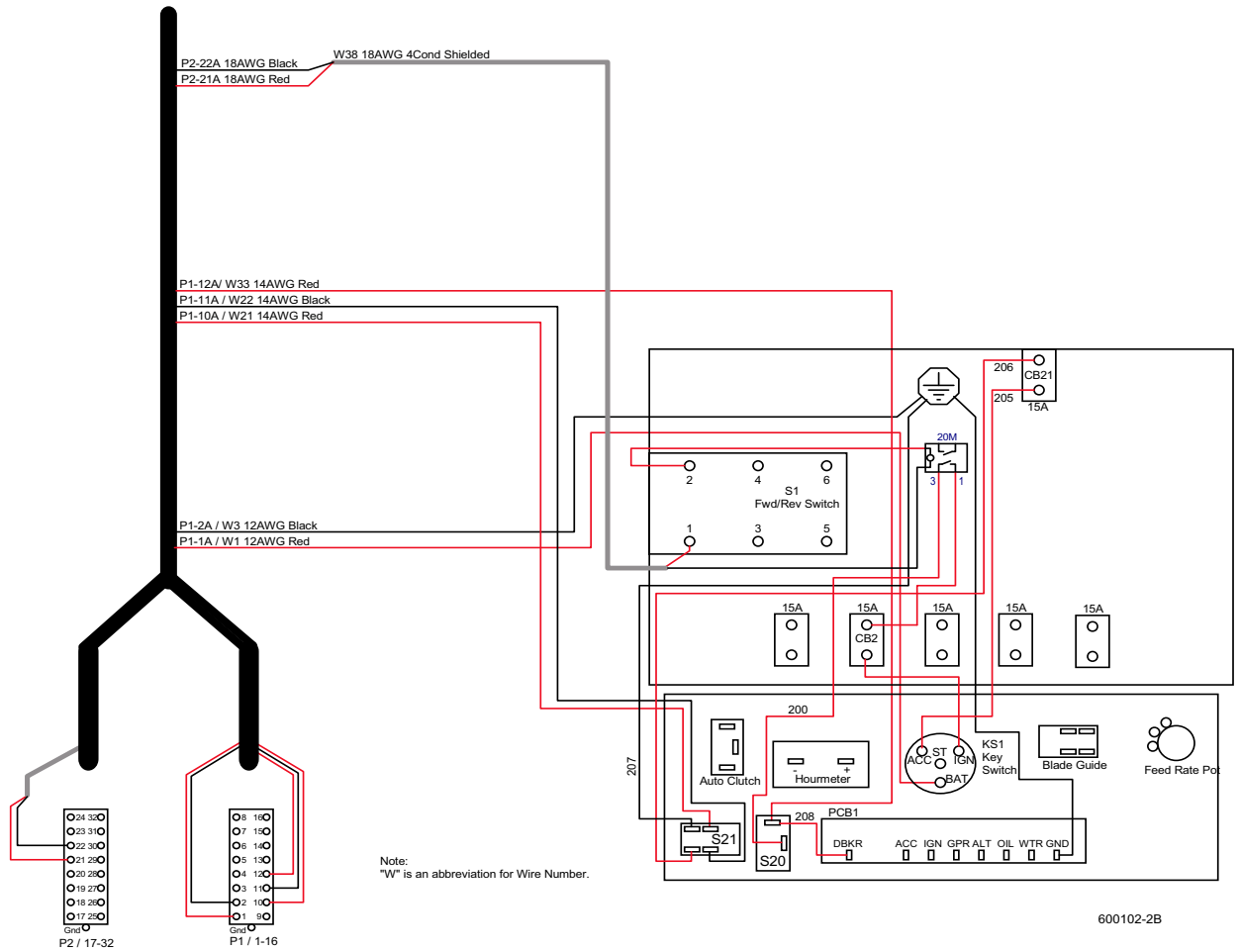

FIG. 5-7 (PAGE 2 OF 2)

5.6 Debarker Electrical Wiring Diagram (AC Wireless Sawmills)

Low/High Voltage

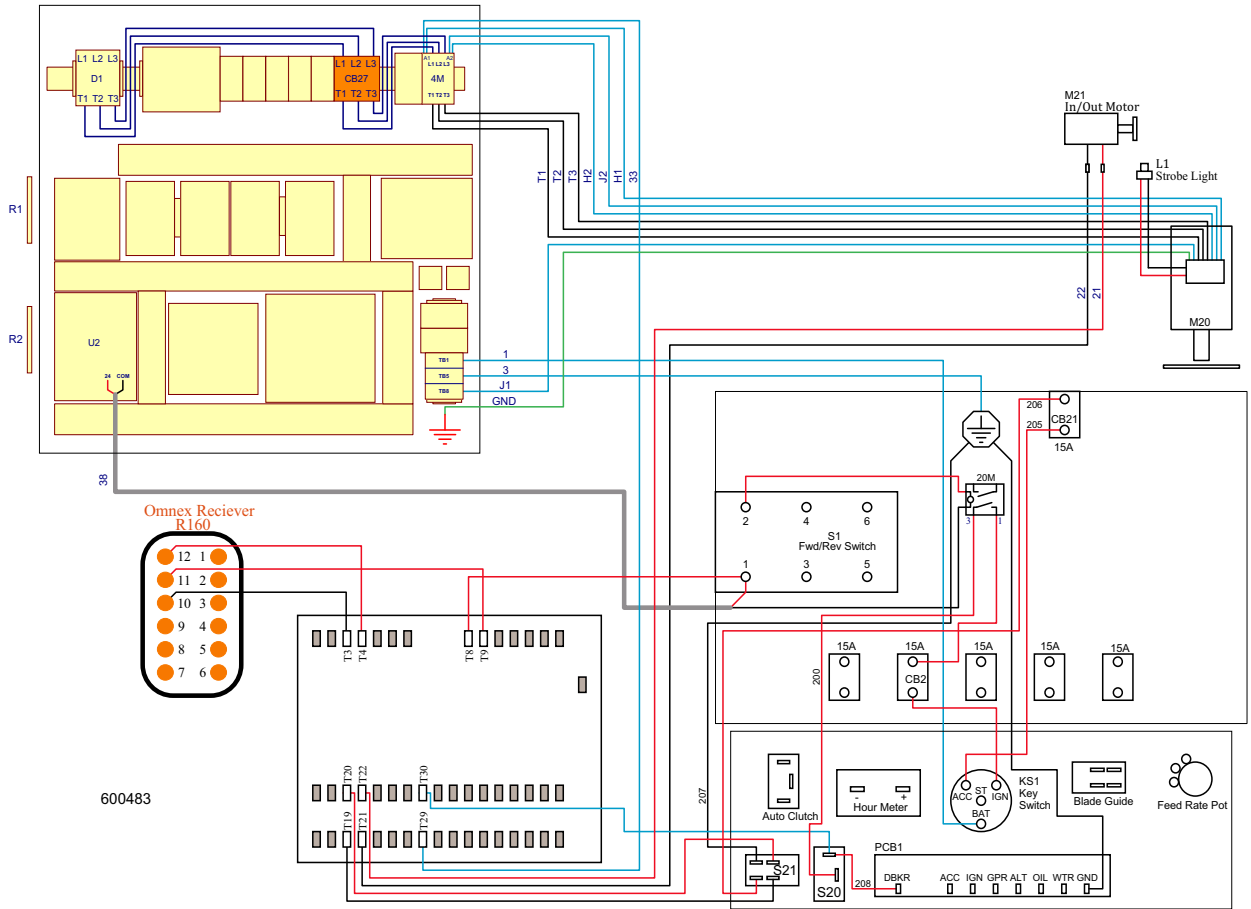
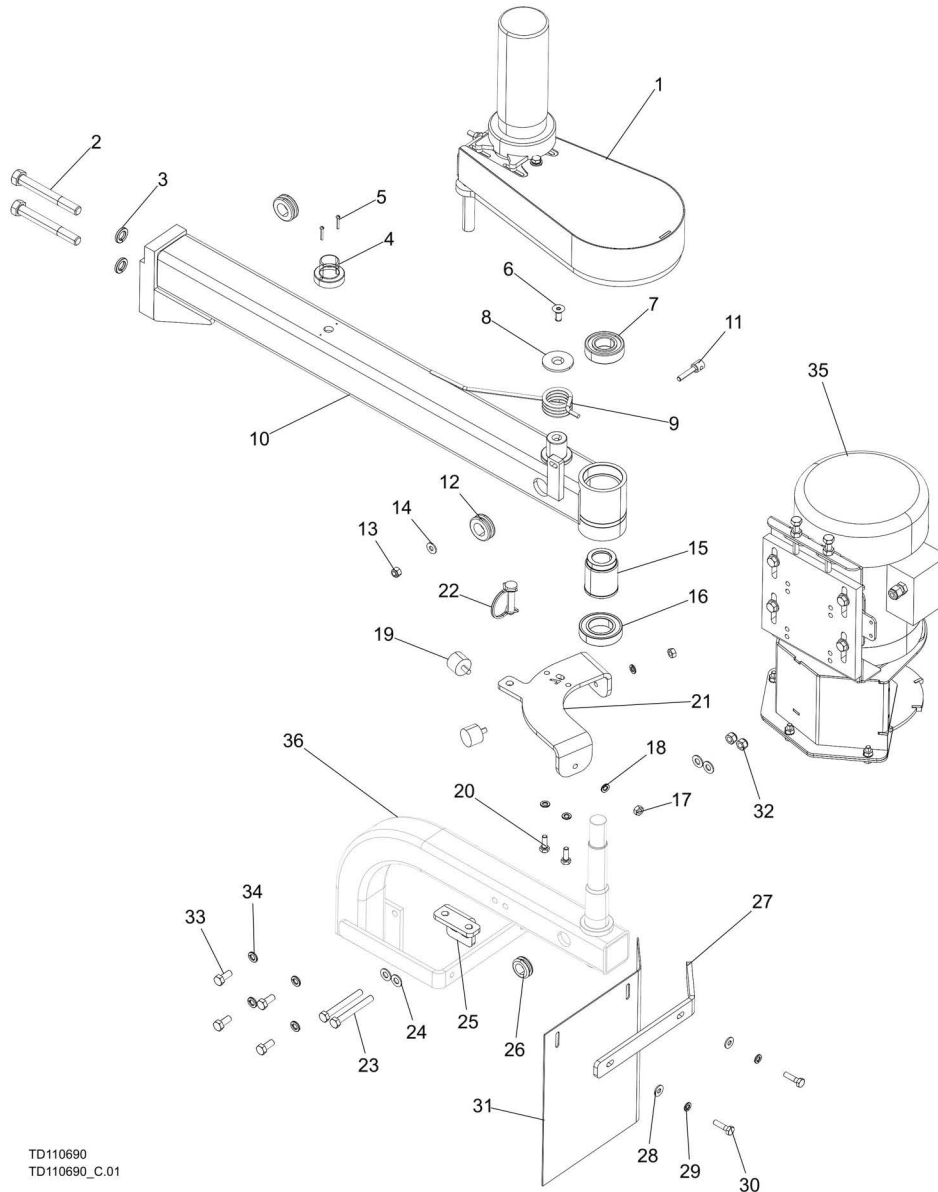

FIG. 5-8

SECTION 6 REPLACEMENT PARTS

6.1 LT70 AC Mechanical Debarker



TD110690
TD110690_C.01

REF	PART #	DESCRIPTION	COMMENTS	QTY.
	110690	Assy, LT70 AC Mechanical Debarker		
	110690W	Assy, LT70 Wide AC Mechanical Debarker		
1		LT70E UPPER PIVOT WITH LOCK	(See Section 6.2)	1
	110684	Assy, LT70 Debarker Mnt Arm		1
2	F05008-78	1/2-13 x 4 HHB GR5 ZINC		2
3	F05011-9	Washer, 1/2 Split Lock		2
	073555	Lamp Assy, 180 Degree Amber Strobe		1

REF	PART #	DESCRIPTION	COMMENTS	QTY.
4	073554	Lamp, 180 Degree Amber Strobe		1
5	F05004-13	Bolt, #4-40x3/4 SI		2
6	F05006-95	Bolt, 5/16-18x3/4 FHS Zinc		1
7	087353	Bearing, 6205 2RS Ball		1
8	076039	Washer, LT35 Torsion Spring		1
9	098605	Spring, Debarker Torsion		1
10	110613	Wldmt, LT70 Debarker Mount Arm		1
11	076139	Bushing, Debarker Spring Retaining		1
12	025247	Grommet, Rubber 3/4 ID		2
13	F05010-69	Nut, 1/4-20 Nylock		1
14	F05011-11	Washer, 1/4 SAE Flat		1
15	110588	Tube, Long Bearing Spacer		1
16	036007	Bearing, R20-2RS		1
	074878	Assy, LT70 Debarker Pivot Stop		1
	074879	Assy, LT70 Wide Debarker Pivot Stop		1
17	F05010-63	Nut, 1/4-20 Free Hex		2
18	F05011-14	Washer, 1/4 Split Lock		4
19	065717	Bumper, 1x3/4 Rubber		2
20	F05005-123	Bolt, 1/4-20x3/4 HH Gr5		2
21	076682	Plate, LT70 Debarker Pivot Stop		1
	076683	Plate, LT70 Wide Debarker Pivot Stop		1
22	046412	Pin, 3/8x1 3/8 Rnd Wire Lock		1
	110689	Assy, LT70 AC Debarker Pivot Arm		1
23	F05006-136	Bolt, 5/16-18x2 3/4 FT HH Gr5 Zinc		2
24	F05011-17	Washer, 5/16 SAE Flat		4
25	110616	Lock Brkt, Debarker Travel		1
26	033475	Grommet, 5/8 ID 3/16 GW Rubber		1
27	076749	Plate, Debarker Flex Guard Retaining		1
28	F05011-11	Washer, 1/4 SAE Flat		1
29	F05011-14	Washer, 1/4 Split Lock		1
30	F05005-38	Screw, 1/4-20x1 HHC		1
31	021232	Guard, Debarker Flex		1
32	F05010-58	Nut, 5/16-18 Nyl Lock		2
33	F05006-5	Bolt, 5/16-18x3/4 HH Gr2		1
34	F05011-13	Washer, 5/16 Split Lock		1
35	074858	Assy, LT70 AC Debarker Cutter Head	(See Section 6.3)	1
36	110685	Wldmnt, LT70 Debarker Pivot Arm		1

6.2 Upper Pivot With Lock

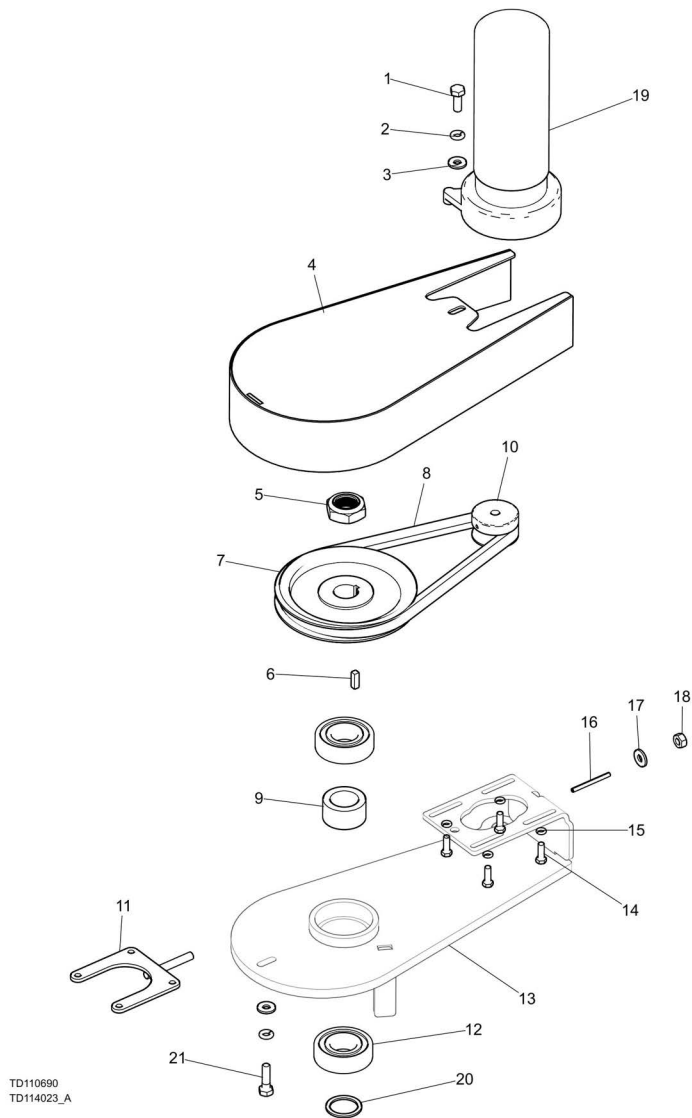

REF	PART #	DESCRIPTION	COMMENTS	QTY.
		LT70E UPPER PIVOT WITH LOCK		1
1	F05005-1	Bolt, 1/4-20x3/4 FT HHC		1
2	F05011-14	Washer, 1/4 Split Lock		2
3	F05011-11	Washer, 1/4 SAE Flat		2
4	076713	Wldmnt, LT70 Debarker Belt Guard		1
5	F05010-238	Nut, 7/8-14 Half Nylock		1
6	065214	Key, 3/16 Sq x 5/8		1
7	076798	Pulley, 5x7/8 A Groove		1
8	076689	Belt, AX22		1
	114023	Assy, LT70E Deb. Upper Pivot W/O Lock		1
9	076741	Tube, Short Bearing Spacer		1
10	076666	Sheave, LT70 Debarker Gearmotor		1
11	023637	Tensioner Wldmt, Gearmotor		1
12	087353	Bearing, 6205 2RS Ball		2

REF	PART #	DESCRIPTION	COMMENTS	QTY.
13	110635	Wldmnt, LT70 Deb. Upper Pivot W/O Lock		1
14	F05004-152	Bolt, #10-32x5/8 HH		4
15	F05011-20	Washer, #10 Split Lock		4
16	F05012-102	Pin, 1/8x1 5/8 Roll Zinc		1
17	F05011-11	Washer, 1/4 SAE Flat		1
18	F05010-21	Nut, 1/4-20 Swaged		1
	114022	Motor Assy, Debarker In/Out w/Brake w/Di		1
19	110952	Motor, 1/15HP 34RPM 12VDC 98:1 W/Brake		1
	069677	Diode, 200V 2A UltraFast Rectifier		2
	024032	Conn, 14-16AWG Parallel Splice		4
	R01950-0	Tubing, 3/32" Heat Shrink		2.5"
	R01950-3	Tubing, 3/16" Heat Shrink		7"
	R01950-10	Tubing, 1/2" Heat Shrink		5"
	069474	Connector, 3 Pin Trig DT Deutsch Male		1
	069475	Wedgelock, 3P Male Deutsch DT Series		1
	053429	Pin, #16 Deutsch 16-20 AWG Solid Contact		1
	R01920-4	Wire, 16AWG Stranded Blue MTW		12"
	R02370	Conduit, 3/8" Expandable Black		9"
	F05089-8	Tie Wrap, 3/16x10 UV Blk		1
20	076037	Shim, 1 ID 1-1/4 OD		1
21	F05005-101	BOLT, 1/4-20 X 1 HEX HEAD GR5		1

For field installation please see online form #2504 in manuals section.

6.3 LT70 AC Debarker Cutter Head

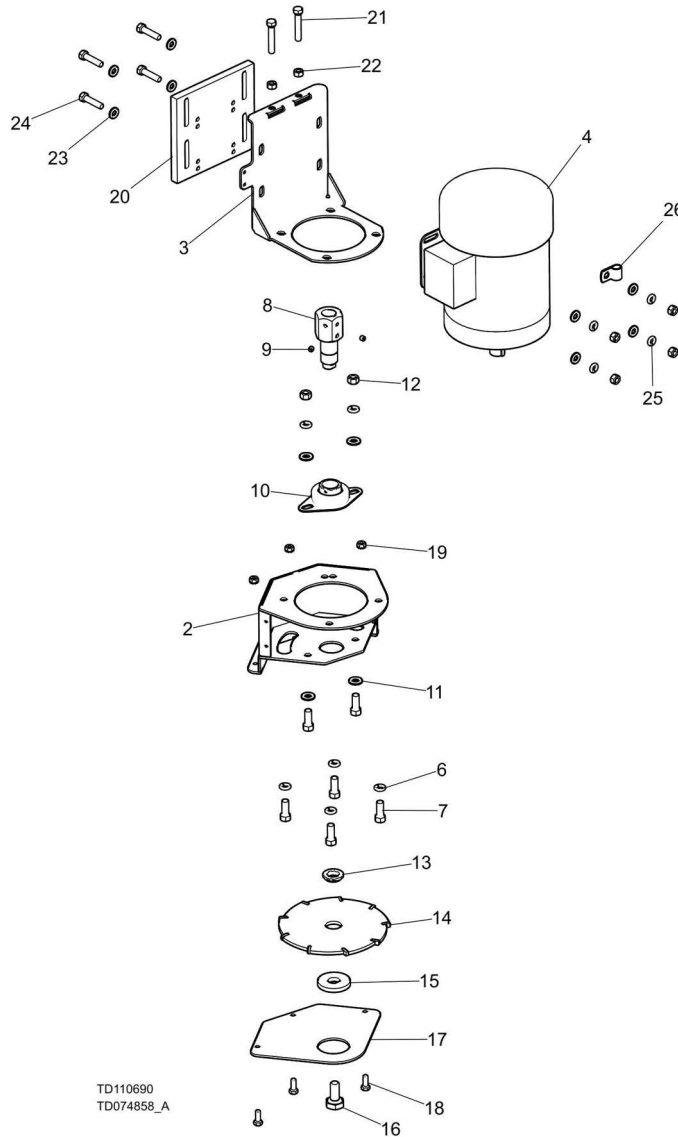

REF	PART #	DESCRIPTION	COMMENTS	QTY.
	074858	Assy, LT70 AC Debarker Cutter Head		1
1	F05006-2	Bolt, 5/16-18x1 1/2 HH FT		4
2	F05011-17	Washer, 5/16 SAE Flat		8
3	023620	Aluminum Plate, Motor Mnt		1
4	023622	Tensioner Weldment		1
5	F05006-13	Bolt, 5/16-18x2 HH FT		2
6	F05010-17	Nut, 5/16-18 Hex		6
7	050292	Motor, 3/4HP 230/460 3P 1725RPM		1
8	P07584	Clamp, 1/2EMT Coated		1
9	F05011-13	Washer, 5/16 Split Lock		4
10	074832	Mandrel, Debarker Blade		1
11	F05005-105	1/4-28X1/4 Cup Point Set, B/O		2
12	F05010-1	Nut, 3/8-16 Hex		2

REF	PART #	DESCRIPTION	COMMENTS	QTY.
13	023541	Bearing, 1 Flanged Mount		1
14	F05010-9	Nut, 1/4-20 Keps		3
15	076686	Wldmnt, LT70 Debarker Cutter Head		1
16	F05011-3	Washer, 3/8 Flat SAE		4
17	F05011-4	Washer, 3/8 Split Lock		6
18	F05007-7	Bolt, 3/8-16x1 HH		6
19	023632	Bushing, Blade Spacer		1
20	021236	Blade, 7in Dia (Debarker)		1
21	023737	Washer, Blade Bolt Lock		1
22	023629	Guard, Cutter Head Bottom		1
23	F05005-1	Bolt, 1/4-20x3/4 FT HHC		3
24	074833	Bolt, 1/2-20x1 1/4 HH Special		1

6.4 Mechanical Assembly (AC)

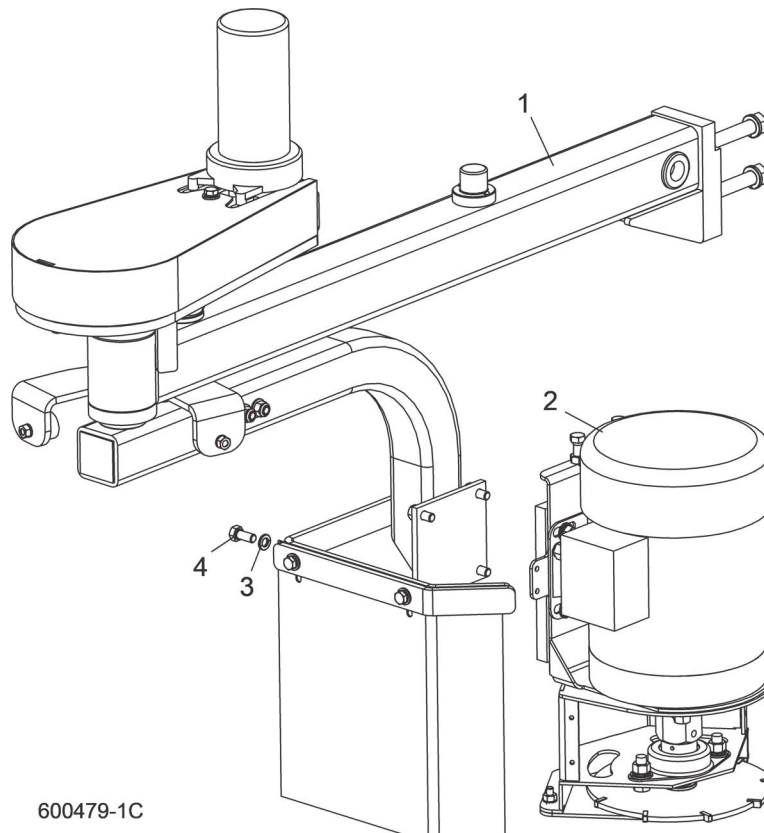

REF	PART #	DESCRIPTION	COMMENTS	QTY.
		NOTE: For field installation of existing sawmills, order the mechanical assembly below plus the appropriate control kit (See Section 6.8):		
	074883	MECHANICAL ASSEMBLY, 70HD AC DEBARKER (BOXED)		1
	074720	MECHANICAL ASSEMBLY, 70HD WIDE AC DEBARKER (BOXED)		1
	110690	Debarker Assembly, LT70 AC Mechanical		
	074860	Debarker Assembly, LT70 AC Mechanical		1
	110690W	Debarker Assembly, LT70 Wide AC Mechanical		
	074860W	Debarker Assembly, LT70 Wide AC Mechanical		1
1		Frame Parts (See Section 6.11)		
2		Cutter Head Parts (See Section 6.6)		
3	F05011-13	Washer, 5/16" Split Lock		4
4	F05006-5	Bolt, 5/16-18 x 3/4" Hex Head		4
	076683	Plate, LT70 Wide Debarker Pivot Stop		1
	015761	Cover, 3/4HP Leeson Motor		1

Frame Assembly (AC)

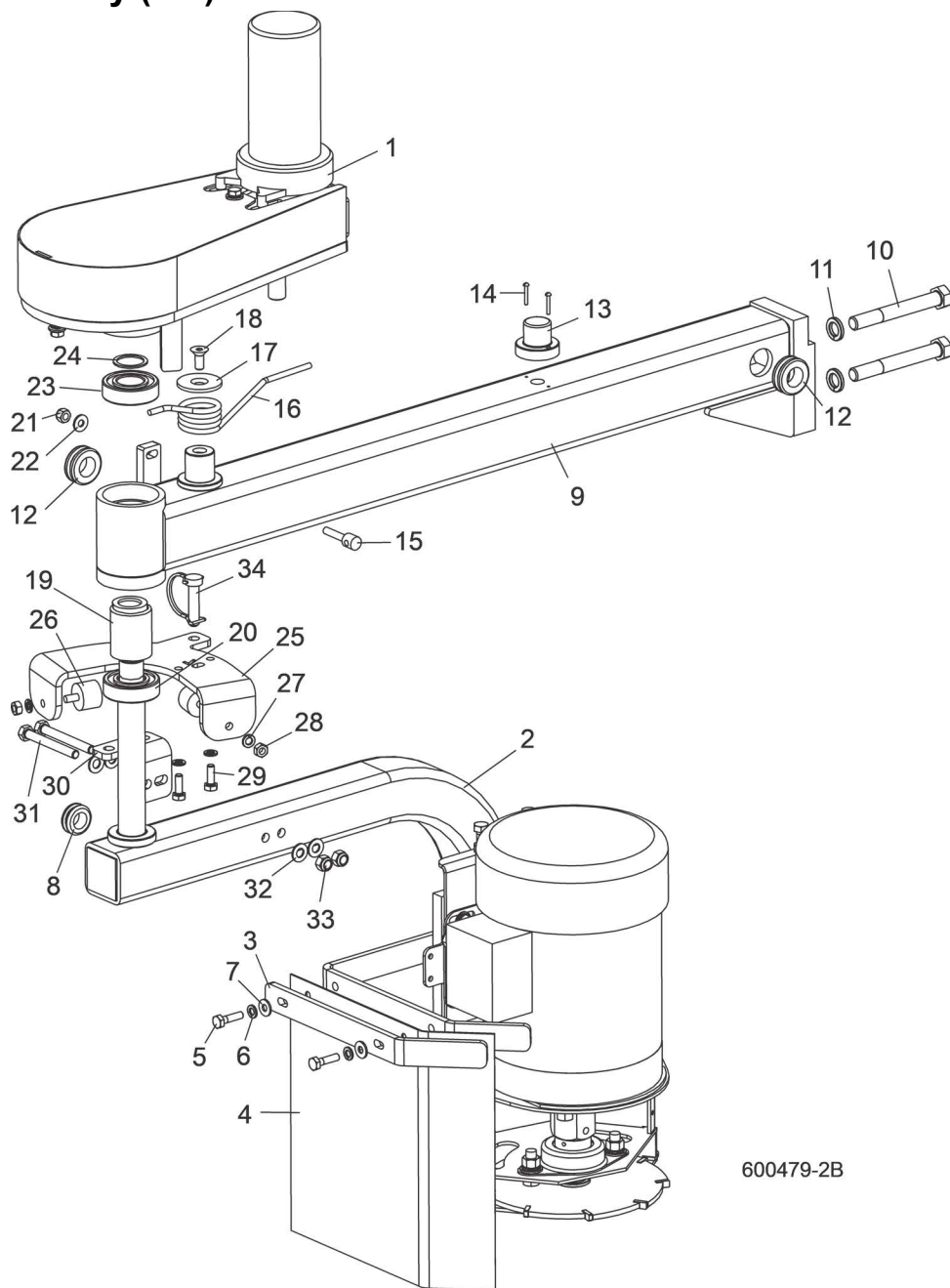

600479-2B

REF	PART #	DESCRIPTION	COMMENTS	QTY.
1		DEBARKER IN/OUT MOTOR PARTS (See Section 6.5)		
	110689	PIVOT ARM ASSEMBLY, LT70 AC DEBARKER	110689 replaced 110640 after 5/23/2019 per ECN 35897.	1
	110640	PIVOT ARM ASSEMBLY, LT70 AC DEBARKER		1
2	110685	Arm Weldment, LT70 Debarker Pivot	110685 replaced 110638 after 5/23/2019 per ECN 35897.	1
	110638	Arm Weldment, LT70 Debarker Pivot		1
3	076749	Plate, Debarker Flex Guard Retaining		1
4	021232	Guard, Debarker Flex		1
5	F05005-38	Bolt, 1/4-20 x 1" Hex Head		2
6	F05011-14	Washer, 1/4" Split Lock		2
7	F05011-11	Washer, 1/4" SAE Flat		2

REF	PART #	DESCRIPTION	COMMENTS	QTY.
8	033475	Grommet, 5/8" ID 3/16" GW Rubber		1
		AC Cutter Head Parts <i>(See Section 6.6)</i>		
	110684	MOUNT ARM ASSEMBLY, LT70 DEBARKER	110684 replaced 110648 after 5/23/2019 per ECN 35897.	1
	110648	MOUNT ARM ASSEMBLY, LT70 DEBARKER		1
9	110613	Mount Arm Weldment, LT70 Debarker	110613 replaced 110647 after 5/23/2019 per ECN 35897.	1
	110647	Mount Arm Weldment, LT70 Debarker		1
10	F05008-78	Bolt, 1/2-13 x 4" Hex Head Grade 5		2
11	F05011-9	Washer, 1/2" Split Lock		2
12	025247	Grommet, Rubber 3/4 ID		2
13	073555	Lamp Assembly, 180 Degree Amber Strobe		1
14	F05004-13	Bolt, 4-40 x 3/4 SI		2
15	076139	Bushing, Debarker Spring Retaining		1
16	098605	Spring, Debarker Tension		1
17	076039	Washer, LT35 Torsion Spring		1
18	F05006-95	Bolt, 5/16-18 x 3/4" FHS		1
19	110588	Tube, Long Bearing Spacer	110588 replaced 076739 after 5/23/2019 per ECN 35897.	1
	076739	Tube, Long Bearing Spacer		1
20	036007	Bearing, R20-2RS	036007 replaced (1) 087353 after 5/23/2019 per ECN 35897.	1
	087353	Bearing, SKF 6205 2RS Roller		1
21	F05010-69	Nut, 1/4-20 Nylock		1
22	F05011-11	Washer, 1/4" SAE Flat		1
23	087353	Bearing, SKF 6205 2RS Roller		1
24	076037	SHIM, 1 ID 1-1/4" OD		1
	074878	STOP ASSEMBLY, LT70 DEBARKER PIVOT		1
	074879	STOP ASSEMBLY, LT70 WIDE DEBARKER PIVOT (WIDE HEAD ONLY)		1
25	076682	Plate, LT70 Debarker Pivot Stop		1
	076683	Plate, LT70 Wide Debarker Pivot Stop (Wide Head Only)		1
26	065717	Bumper, 1 x 3/4" Hard Silicone Rubber		2
27	F05011-14	Washer, 1/4" Split Lock		2
28	F05010-63	Nut, 1/4-20 Free		2
29	F05005-123	Bolt, 1/4-20 x 3/4" Hex Head Grade 5		2
30	110616	LOCK BRACKET, DEBARKER TRAVEL		1
31	F05006-136	BOLT, 5/16-18X2 3/4 FT HH GR5		2
32	F05011-17	WASHER, 5/16 SAE FLAT		4
33	F05010-58	NUT, 5/16-18 NYLOK HEX		2
34	046412	PIN, 3/8X1 3/8 ROUND WIRE LOCK		1

6.5 In/Out Motor Drive Assembly

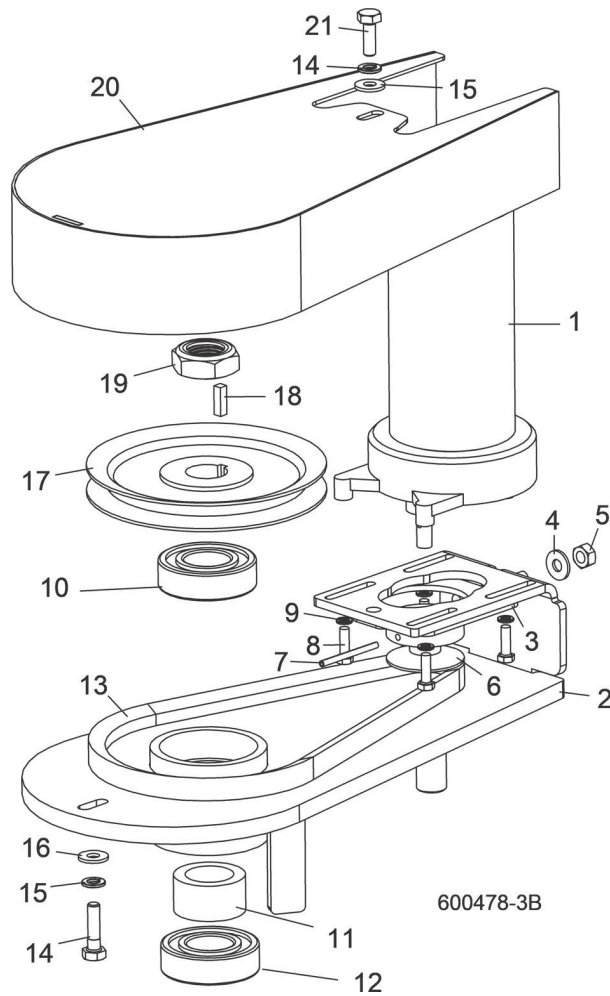

REF	PART #	DESCRIPTION	COMMENTS	QTY.
	110634	PIVOT ASSEMBLY, LT70 DEBARKER UPPER		1
1	128026	Motor Assy, Debarker In/Out w/Brake w/Di		1
	074826	Gearmotor Assembly, LT70 Debarker In/Out		1
	061228	Gear Kit, Motor		1
	061229	Shaft Kit, Motor		1
	061230	Brush Kit, Motor		1
2	110635	Pivot Weldment, LT70 Debarker Upper		1
3	023637	Tensioner Weldment, Gear Motor		1
4	F05011-11	Washer, 1/4" SAE Flat		1
5	F05010-21	Nut, 1/4-20 Swaged		1
6	076666	Sheave, LT70 Debarker Gearmotor		1
7	F05012-102	Pin, 1/8 x 1 5/8 Roll		1
8	F05004-152	Screw, 10-32 x 5/8 HH Machine		4
9	F05011-20	Washer, #10 Split Lock		4
10	087353	Bearing, SKF 6205 2RS Roller		1
11	076741	Tube, Short Bearing Spacer		1
12	036007	Bearing, R20-2RS	036007 replaced (1) 087353 after 5/23/2019 per ECN 35897.	1
13	076689	BELT, AX22		1

REF	PART #	DESCRIPTION	COMMENTS	QTY.
14	F05005-101	BOLT, 1/4-20 X 1" HEX HEAD GRADE 5		1
15	F05011-14	WASHER, 1/4" SPLIT LOCK		2
16	F05011-11	WASHER, 1/4" SAE FLAT		2
17	076798	PULLEY, 5X7/8 A GROOVE		1
18	065214	KEY, 3/16" SQ X 5/8"		1
19	F05010-238	NUT, 7/8-14 HALF NYLOCK		1
20	076713	GUARD WELDMENT, LT70 DEBARKER BELT		1
21	F05005-1	BOLT, 1/4-20 X 3/4" FULL THREAD HHC		1

6.6 Blade Motor Assembly (AC)

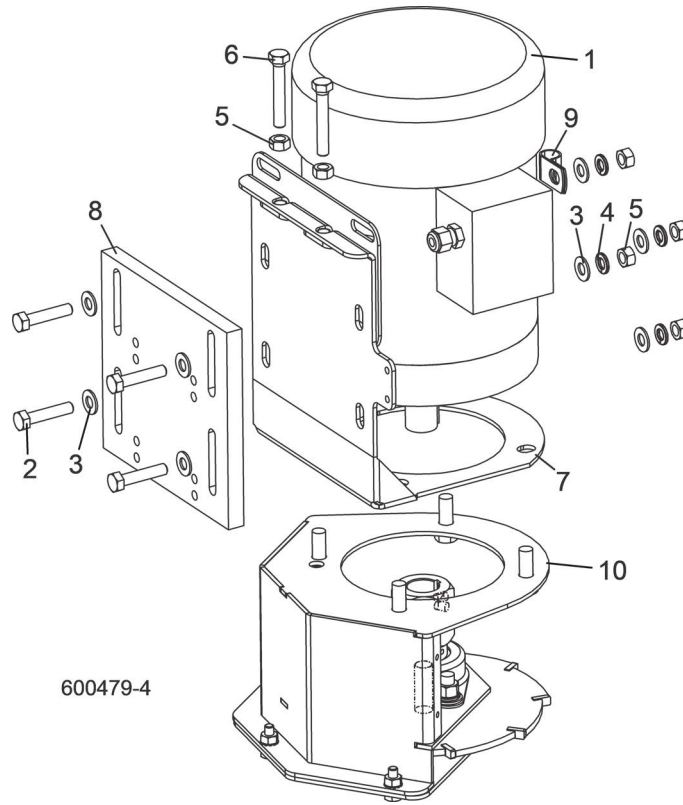

REF	PART #	DESCRIPTION	COMMENTS	QTY.
	074858	HEAD ASSEMBLY, LT70 AC DEBARKER CUTTING		1
1	050292	Motor, 3/4HP 230/460V 1725RPM Electric		1
	016108	Key, 3/16" Square x 1 3/8" Long		1
2	F05006-2	Bolt, 5/16-18 x 1 1/2" Hex Head Full Thread		4
3	F05011-17	Washer, 5/16" SAE Flat		8
4	F05011-13	Washer, 5/16" Split Lock		4
5	F05010-17	Nut, 5/16-18 Hex		6
6	F05006-13	Bolt, 5/16-18 x 2" Hex Head Full Thread		2
7	023622	Bracket Weldment, Debarker Blade Motor Adjustable		1
8	023620	Plate, Debarker Blade Motor Mount		1
9	P07584	Clamp, 1/2EMT Coated		1
	024431	Decal, Disconnect Motor Leads Warning		1
10		Blade/Mandrel Parts	<i>(See Section 6.7)</i>	

6.7 Blade Housing Assembly

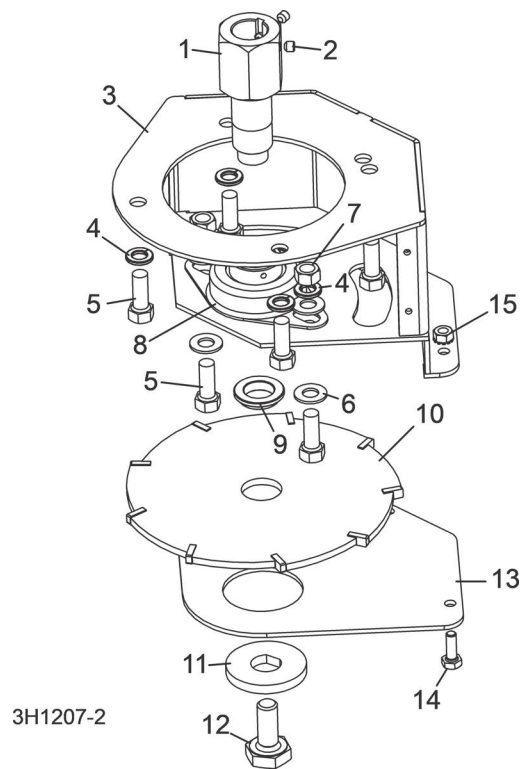

REF	PART #	DESCRIPTION	COMMENTS	QTY.
1	074832	MANDREL, DEBARKER BLADE		1
2	F05005-105	SCREW, 1/4-28 X 1/4" CUP POINT SOCKET SET		2
3	076686	HEAD WELDMENT, LT70 DEBARKER CUTTER		1
4	F05011-4	WASHER, 3/8" SPLIT LOCK		6
5	F05007-7	BOLT, 3/8-16 X 1" HEX HEAD		6
6	F05011-3	WASHER, 3/8" SAE FLAT		4
7	F05010-1	NUT, 3/8-16 HEX		2
8	023541	BEARING, 1" FLANGED MOUNT		1
9	023632	BUSHING, DEBARKER BLADE SPACER		1
10	021236	BLADE, DEBARKER 7" DIA.		1
	065852	BLADE, DEBARKER 7" DIA. W/1/2" INSERTS	OPTIONAL	1
11	023737	WASHER, DEBARKER BLADE LOCK		1
12	074833	BOLT, 1/2-20 X 1 1/4" HEX HEAD SPECIAL		1
13	023629	PLATE, DEBARKER BLADE HOUSING BOTTOM		1
14	F05005-1	BOLT, 1/4-20 X 3/4" HEX HEAD FULL THREAD		3
15	F05010-9	NUT, 1/4-20 SELF-LOCKING HEX		3
	076799	DECAL, DEBARKER LIGHT WARNING		1

6.8 Debarker Control Assembly

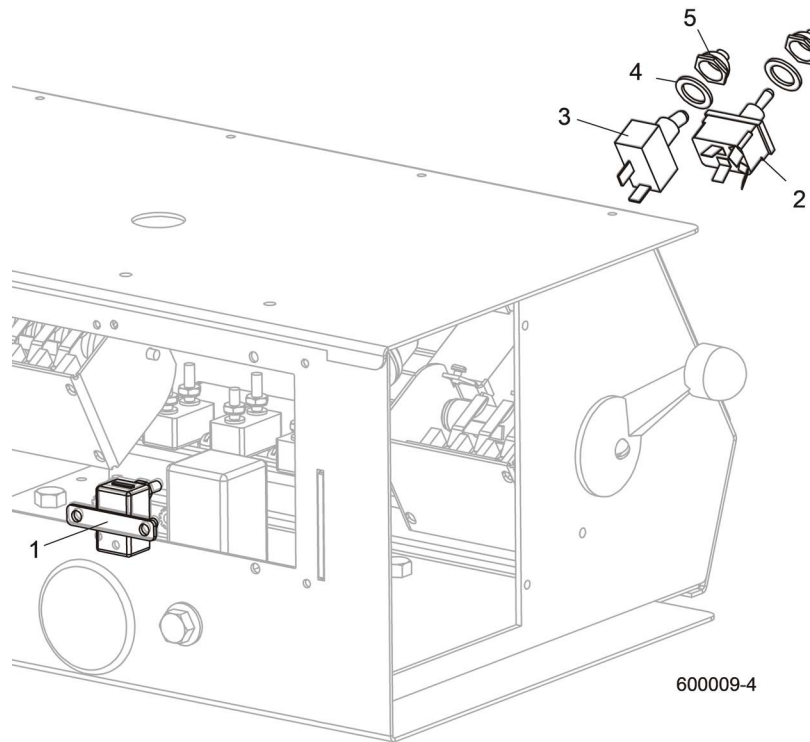

REF	PART #	DESCRIPTION	COMMENTS	QTY.
	050912	CONTROL ASSEMBLY, DEBARKER AC LT70		1
	050428	Harness Assembly, Debarker AC LT70 E25/E30		1
1	E20430	Breaker, 15 Amp Manual Reset		1
2	024200	Switch, DPDT Toggle Return Center Screw Terminal		1
3	P03027	Switch, SPST Toggle Quick Connect		1
4	P05251-1	Washer, 1/2 x 3/4 x 1/16" Nylon		2
5	P02575	Boot, Toggle Switch		2

