

LT70 DC MKIII Debarker Gas/Diesel Mill Option

**Safety, Installation, Operation,
Maintenance & Parts Manual**

MKIII for LT70 DC Sawmills rev. C.00
(Except LT70 Super Sawmills)*

Safety is our #1 concern!

Form #2087

Models Effected:

LT70HD
LT70HD Remote
LT70HD DC Wireless

*See Operator's and Parts Manuals for LT70
Super Debarker Information



**WARNING! Read and understand this
manual before using this machine.**

California

Proposition 65 Warning



WARNING: Breathing gas/diesel engine exhaust exposes you to chemicals known to the State of California to cause cancer and birth defects or other reproductive harm.

Always start and operate the engine in a well-ventilated area.
If in an enclosed area, vent the exhaust to the outside.
Do not modify or tamper with the exhaust system.
Do not idle the engine except as necessary.

For more information go to www.P65warnings.ca.gov.



WARNING: Drilling, sawing, sanding or machining wood products can expose you to wood dust, a substance known to the State of California to cause cancer. Avoid inhaling wood dust or use a dust mask or other safeguards for personal protection.

For more information go to www.P65Warnings.ca.gov/wood.

Active Patents assigned to Wood-Mizer, LLC

Wood-Mizer, LLC has received patents that protect our inventions which are a result of a dedication to research, innovation, development, and design. Learn more at: woodmizer.com/patents

©2024 Wood-Mizer LLC

Printed in the United States of America, all rights reserved. No part of this manual may be reproduced in any form by any photographic, electronic, mechanical or other means or used in any information storage and retrieval system without written permission from

Wood-Mizer, LLC
8180 West 10th Street
Indianapolis, Indiana 46214

SECTION 1 SAFETY

1.1 Safety Symbols 1-1
 1.2 Safety Instructions..... 1-1
 Observe ALL Safety Instructions..... 1-1
 1.3 Installation and Maintenance 1-1
 1.4 Operation and Towing 1-2

SECTION 2 DEBARKER INSTALLATION

2.1 Debarker Installation..... 2-1
 2.2 Harness Installation..... 2-4
 2.3 Control Component Installation (Non-Remote Mills)..... 2-8
 2.4 Control Component Installation (Remote Mills) 2-16

SECTION 3 ALIGNMENT

3.1 Debarker Alignment..... 3-1

SECTION 4 OPERATION AND MAINTENANCE

4.1 Debarker Travel Lock Pin..... 4-1
 4.2 Control Overview 4-2
 4.3 Operation 4-4
 4.4 Maintenance 4-5
 4.5 Debarker Troubleshooting 4-6

SECTION 5 ELECTRICAL INFORMATION

5.1 Debarker Electrical Symbol Diagram (Non-Remote)..... 5-1
 Low Voltage 5-2
 High Voltage 5-3
 5.2 Debarker Electrical Symbol Diagram (Remote)..... 5-4
 Low Voltage 5-5
 High Voltage 5-6
 5.3 Debarker Electrical Component List 5-7
 5.4 Debarker Electrical Wiring Diagram (non-Remote Sawmills)..... 5-8
 LT70HD Rev. B6.07+ 5-8
 Low/High Voltage 5-9
 5.5 Debarker Electrical Wiring Diagram (Remote Sawmills) 5-9
 Low/High Voltage 5-9
 LT70HD Remote Rev. B6.07+..... 5-9
 5.6 Debarker Electrical Wiring Diagram (ACDC Wireless Sawmills) 5-13
 LT70HD DC Wireless Rev. B6.07+ 5-13
 Low/High Voltage 5-13

SECTION 6 REPLACEMENT PARTS

6.1 LT70 DC Mechanical Debarker 6-1
 6.2 Upper Pivot With Lock 6-1
 6.3 LT70 Debarker Cutter Head 6-1
 6.4 Mechanical Assembly (DC)..... 6-1
 6.5 Frame Assembly (DC) 6-2
 6.6 In/Out Motor Drive Assembly 6-6

Table of Contents

Section-Page

6.7	Blade Motor Assembly (DC)	6-8
6.8	Blade Motor Assembly (AC)	6-9
6.9	Blade Housing Assembly	6-10
6.10	Debarker Control Assembly	6-11

SECTION 1 SAFETY

1.1 Safety Symbols

The following symbols and signal words call your attention to instructions concerning your personal safety. Be sure to observe and follow these instructions.

 **DANGER!** indicates an imminently hazardous situation which, if not avoided, will result in serious injury or death.

 **WARNING!** suggests a potentially hazardous situation which, if not avoided, could result in serious injury or death.

 **CAUTION!** refers to potentially hazardous situations which, if not avoided, may result in minor or moderate injury or damage to equipment.

NOTICE indicates vital information.

1.2 Safety Instructions

OWNER/OPERATOR'S RESPONSIBILITY

The procedures listed in this manual may not include all ANSI, OSHA, or locally required safety procedures. **It is the owner/operator's responsibility and not Wood-Mizer LLC to ensure all operators are properly trained and informed of all safety protocols.** Owner/Operators are responsible for following all safety procedures when operating and performing maintenance to the equipment.

Observe ALL Safety Instructions

NOTICE Read the entire Operator's Manual before operating this equipment.

Note all safety warnings throughout this manual and those posted on the machine.

Be able to access this manual at all times while operating this equipment.

Read additional manufacturer's manuals and observe their applicable safety instructions.

Only persons who have read and understood the entire operator's manual should operate this equipment.

This equipment is not intended for use by or around children.

It is the owner/operator's responsibility to comply with all applicable federal, state, and local laws, rules, and regulations regarding the ownership, operation, and transporting your equipment.



Operators should become thoroughly familiar with and comply with these applicable laws for operating and transporting equipment.

 **WARNING!** Clean sawdust from all guards, vents, control boxes, or any area where sawdust may gather **after every shift**. Failure to do so may result in fire, causing death or serious injury.

1.3 Installation and Maintenance

 **DANGER!** On electric mills, hazardous voltage inside the disconnect box, starter box, and at the electric motor can cause shock, burns, or death. Disconnect and lock out power supply before performing debarker installation! Follow all applicable electrical codes.

DANGER! Make sure all electrical installation, service and/or maintenance work is performed by a qualified electrician and is in accordance with applicable electrical codes.

DANGER! Before performing any service to this equipment, turn the key to the OFF position, remove the key, and disconnect the sawmill battery ground terminal.

 **WARNING!** Before replacing the debarker blade, move the sawmill blade guide arm in front of the sawmill blade to cover the blade teeth.

1.4 Operation and Towing



DANGER! Make sure all guards and covers are in place and secured before operating the debarker option. Failure to do so may result in serious injury.

DANGER! Keep all persons out of the path of moving equipment when operating the debarker. Failure to do so will result in serious injury.

DANGER! Always remove the key from the control panel before preparing the debarker for towing. Failure to do so may result in serious injury.



WARNING! Debarker is ON when warning light is on. DO NOT disconnect the warning light. Doing so may result in serious injury.

WARNING! If the debarker continues to run with the key switch in the OFF position, remove the negative battery terminal from the battery post.

DO NOT continue to operate the mill if the main key switch does not control debarker operation. Doing so could result in serious injury. Call Wood-Mizer customer service for more information.

SECTION 2 DEBARKER INSTALLATION



DANGER! On electric mills, hazardous voltage inside the disconnect box, starter box, and at the electric motor can cause shock, burns, or death. Disconnect and lock out power supply before performing debarker installation! Follow all applicable electrical codes.

DANGER! Before performing any service to this equipment, turn the key to the OFF (0) position, remove the key, and disconnect the sawmill battery ground terminal. Failure to do so will result in serious injury or death.



CAUTION! Due to various design changes and past retrofits and options, you should very carefully look your mill over to determine Debarker compatibility before beginning Debarker installation.

2.1 Debarker Installation



DANGER! Always disengage the blade and shut off the sawmill engine before installing the debarker. Failure to do so will result in serious injury.

IMPORTANT! Sawmills are equipped with pre-drilled Debarker mounting holes. **Verify hole locations before beginning Debarker installation. Proper hole location is imperative for safe and effective Debarker operation.**

The debarker wiring is pre-routed and secured at the debarker mounting location with a guard.

1. Remove the guard and route the wiring through the grommet in the saw head.
2. Note the location of the two debarker mounting holes.
3. Assemble the debarker to the sawmill saw head. Align the mounting block holes and the two debarker mounting holes in the saw head.
4. Use the provided 1/2-13 x 4" hex head bolts and 1/2" split lock washers to secure in place.

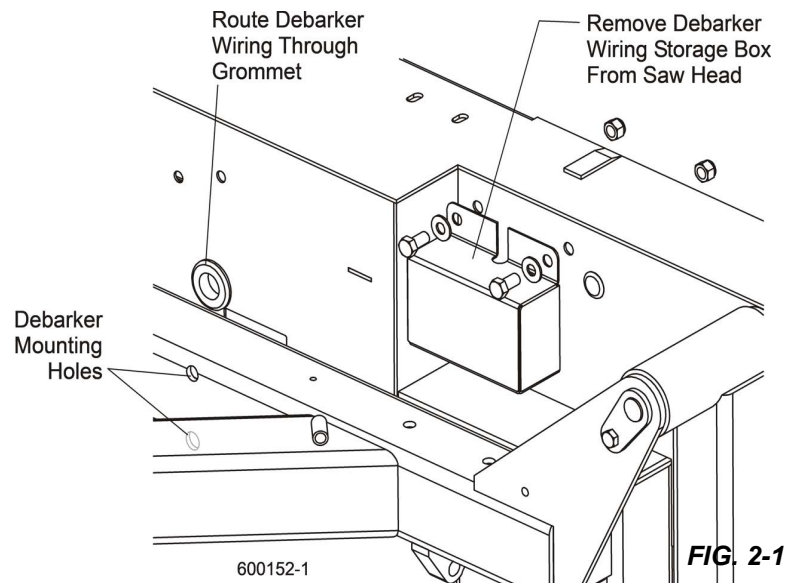

FIG. 2-1

5. Make sure the debarker is square to the saw head before tightening.
6. Assemble the debarker cutting head to the mount plate on the frame.
7. Use the four provided 5/16-18 x 3/4" bolts and 5/16" split lock washers to mount the cutting head to the debarker frame.
8. Use the lower set of four holes in the head mounting plate.

The upper set of holes are provided in the event the cutting head needs to be adjusted further down than the slotted motor mount holes will allow.

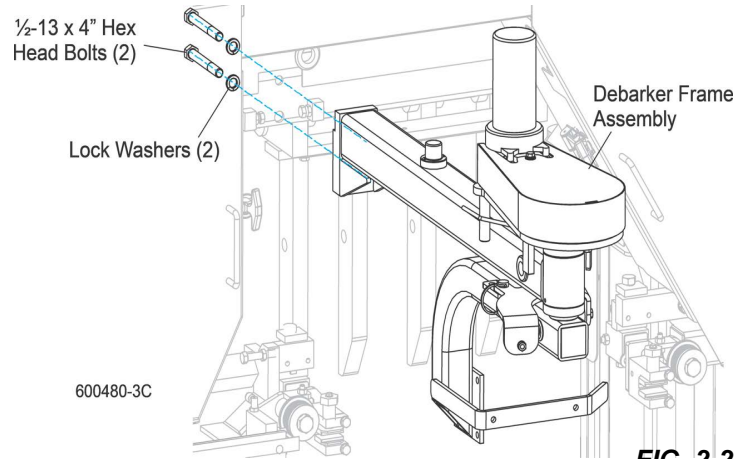

FIG. 2-2

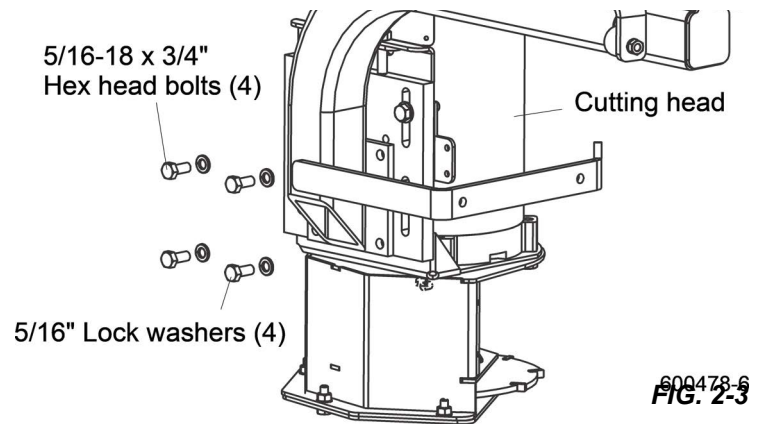

FIG. 2-3

9. Install the blade guard bracket and flexible debris guard to the debarker head with two 1/4" flat washers, lock washers, and 1/4-20 x 1" hex head bolts.
10. Be sure the bottom of the debris guard is even with the bottom of the debarker blade.

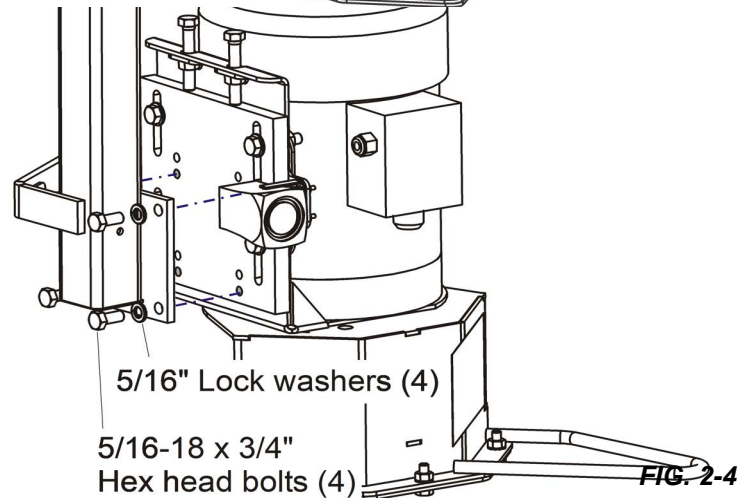
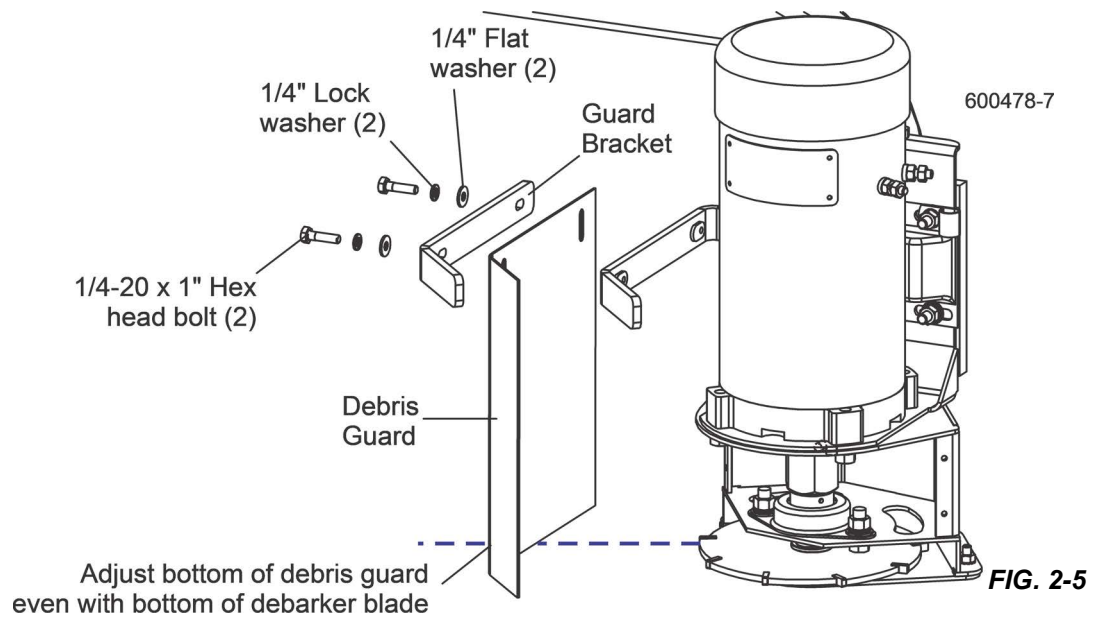
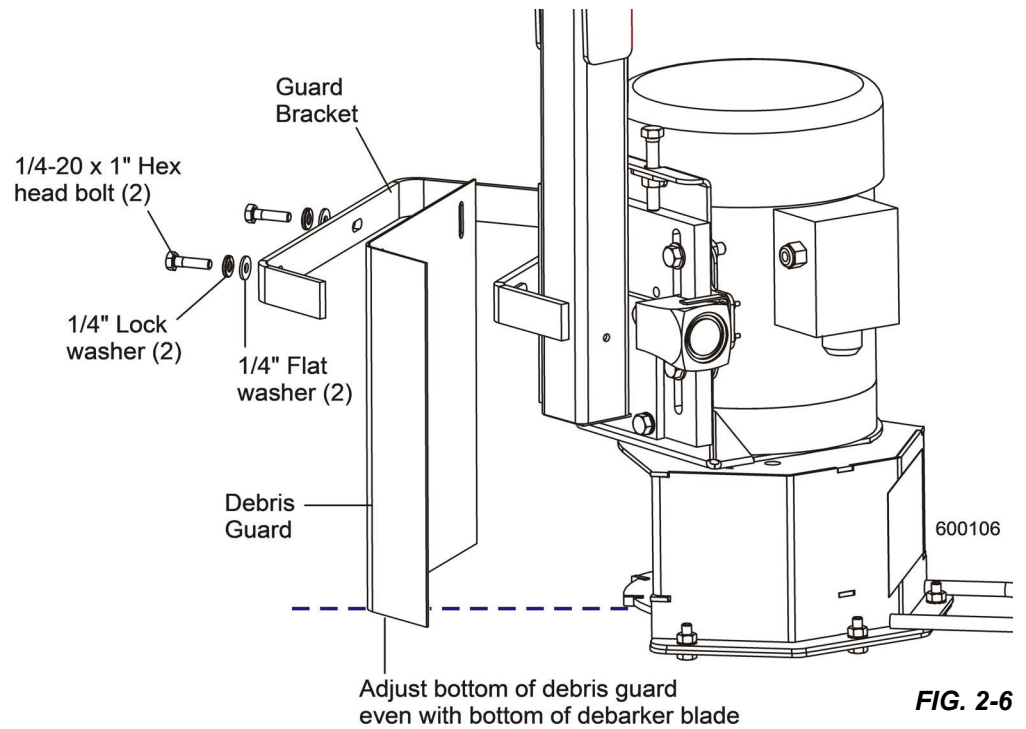

FIG. 2-4



FOR REPLACING OLD DEBARKER FOR LT70 SAWMILLS WITH THE NEW ONE WITH MOTOR PLEASE SEE ONLINE INSTRUCTION SHEET.



2.2 Harness Installation



DANGER! On electric mills, hazardous voltage inside the disconnect box, starter box, and at the electric motor can cause shock, burns, or death. Disconnect and lock out power! Follow all applicable electrical codes.

DANGER! Before performing any service to this equipment, turn the key to the OFF (0) position, remove the key, and disconnect the sawmill battery ground terminal. Failure to do so will result in serious injury or death.

NOTICE Avoid pinch and pivot points, unnecessary wire bending and open spaces where the wire could get caught by a log, etc. If you have any questions, call Wood-Mizer customer service.

1. Route the harnesses through the saw head frame hole as shown.
2. Continue routing the long blade motor wire harness (large wires/ring terminals) inside the debarker frame through the three holes with grommets.

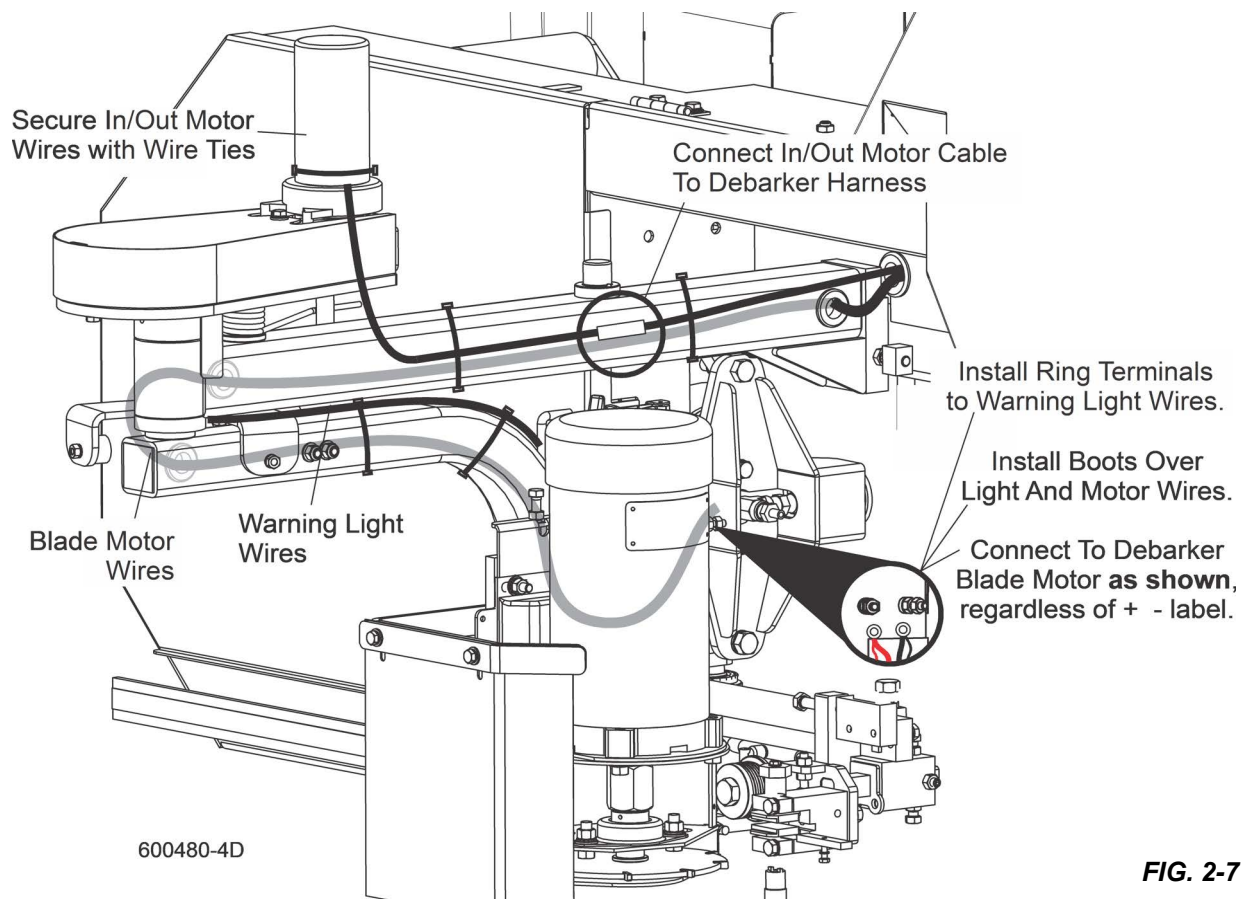

FIG. 2-7

3. Cut the conduit of the in/out motor wire harness to expose the quick connect terminals.
4. Remove the rubber cap from the in/out motor and install the removed conduit around the in/out motor wires.
5. Route the wires down the side of the in/out motor to the quick connects.
6. Be sure to leave slack in the harness to avoid kinking and bending as the debarker moves in and out.
7. Replace the motor cap and secure the harness to the in/out motor by connecting two wire ties together and wrapping around the motor.
8. Connect the in/out motor wire harness to the in/out motor saw head harness.
9. Secure the harness to the blade motor frame with wire ties.

10. Route the warning light harness on top of the blade motor pivot arm to the debarker blade motor.
11. Secure the warning light wires to the pivot arm with wire ties as shown above.

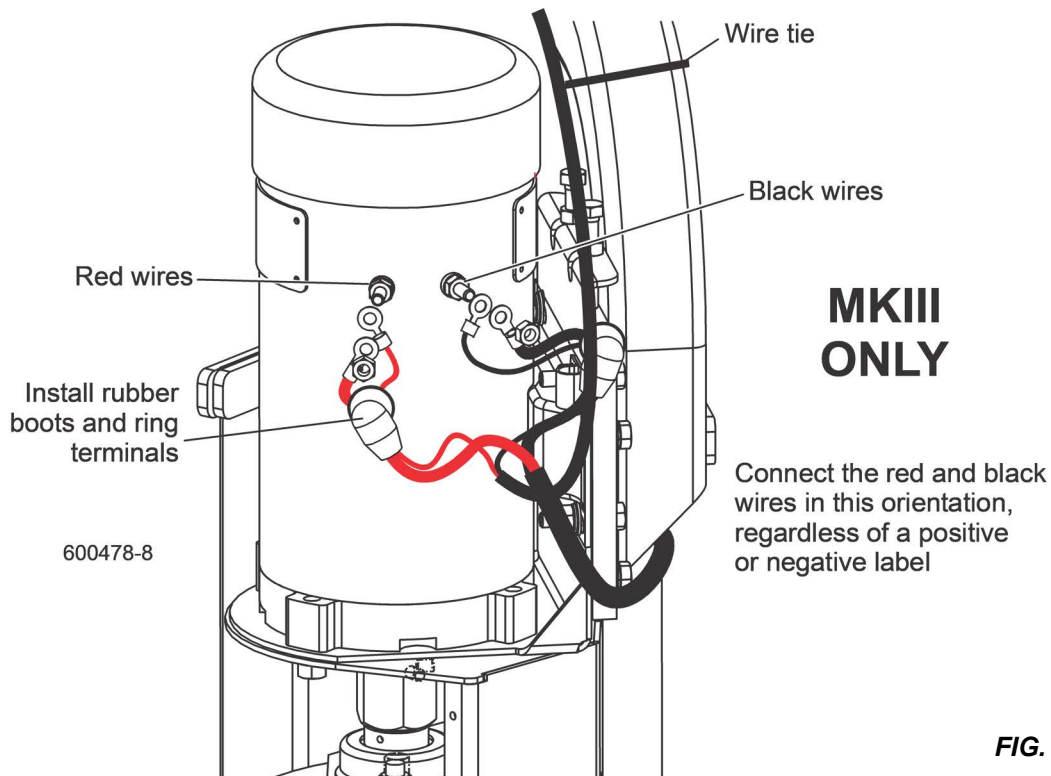

FIG. 2-8

12. Remove the top nuts from each of the motor terminals.

NOTICE Make sure that the ring terminals do not touch the motor body.

13. Connect both black wires to the **right motor terminal** and replace the terminal nut to secure the wires. **Reference figure 2-6.**

NOTICE Make sure that the ring terminals do not touch the motor body.

14. Slide the rubber boots over the motor terminal posts to protect the connections.

1. Install the supplied wire harness to the debarker motor junction box.
2. Insert the end of the harness with bare wire ends through the hole in the bottom of the debarker motor junction box and secure with the harness connector.
3. Leave approximately 1/2" of harness conduit past the connector.

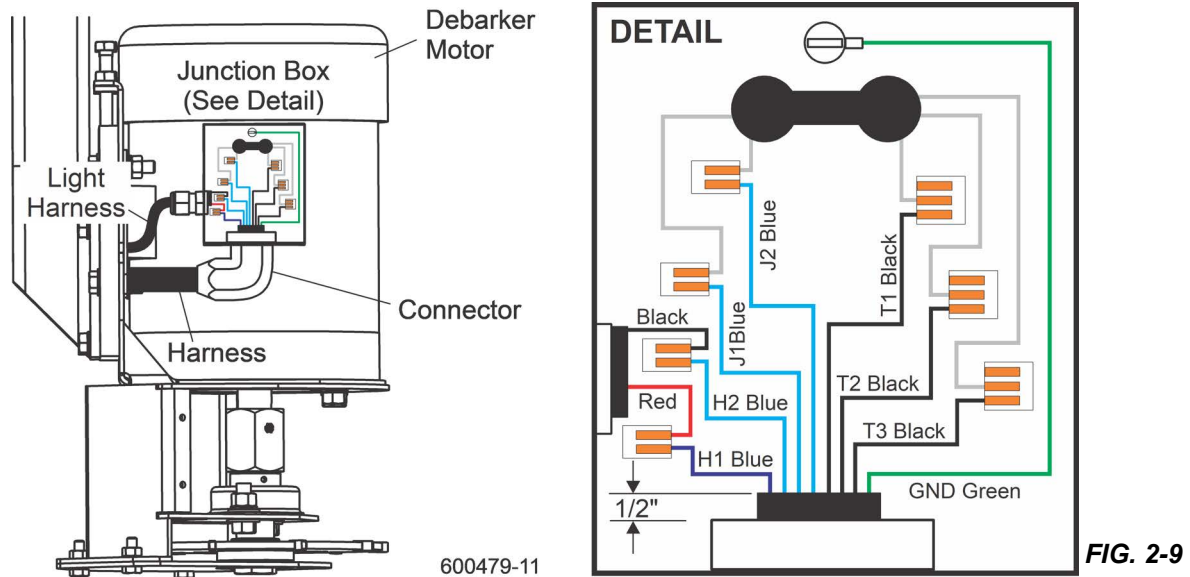

4. Connect the harness wires to the corresponding debarker motor wires, matching the wire labels as shown.
5. Connect the green GND wire to the ground terminal in the motor junction box.
6. Route the harness through the hole in the saw head.
7. Locate the two-wire harness supplied with the sawmill for the debarker in/out motor.
This harness is bundled with other harnesses underneath the sawmill motor.

8. Route the two-wire harness through the hole in the saw head, toward the debarker.
9. Connect the harness to the debarker in/out motor connector.

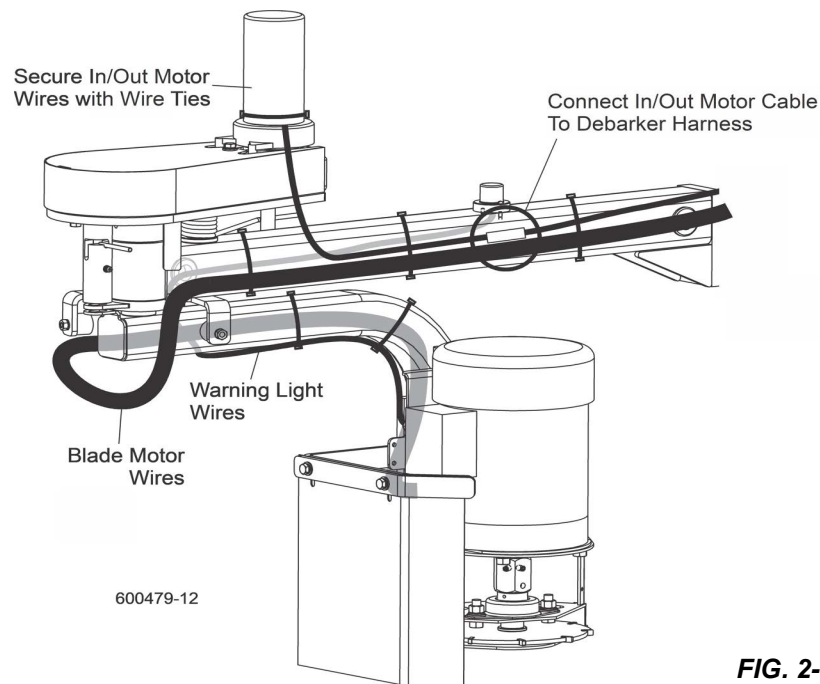

10. Continue routing the large harness from the debarker motor under the sawmill motor, toward the electrical control cabinet.
11. Remove the plug from the hole in the bottom of the cabinet and push the harness up into the box.

12. Secure the harness to the cabinet hole with the provided connector, leaving approximately 1/2" of harness conduit past the connector.
13. Use the provided wire tie to secure the harness to existing harnesses under the sawmill motor.
14. In the control cabinet, remove the wireway covers and route the harness wires to the appropriate components. Only wires listed above are shown.

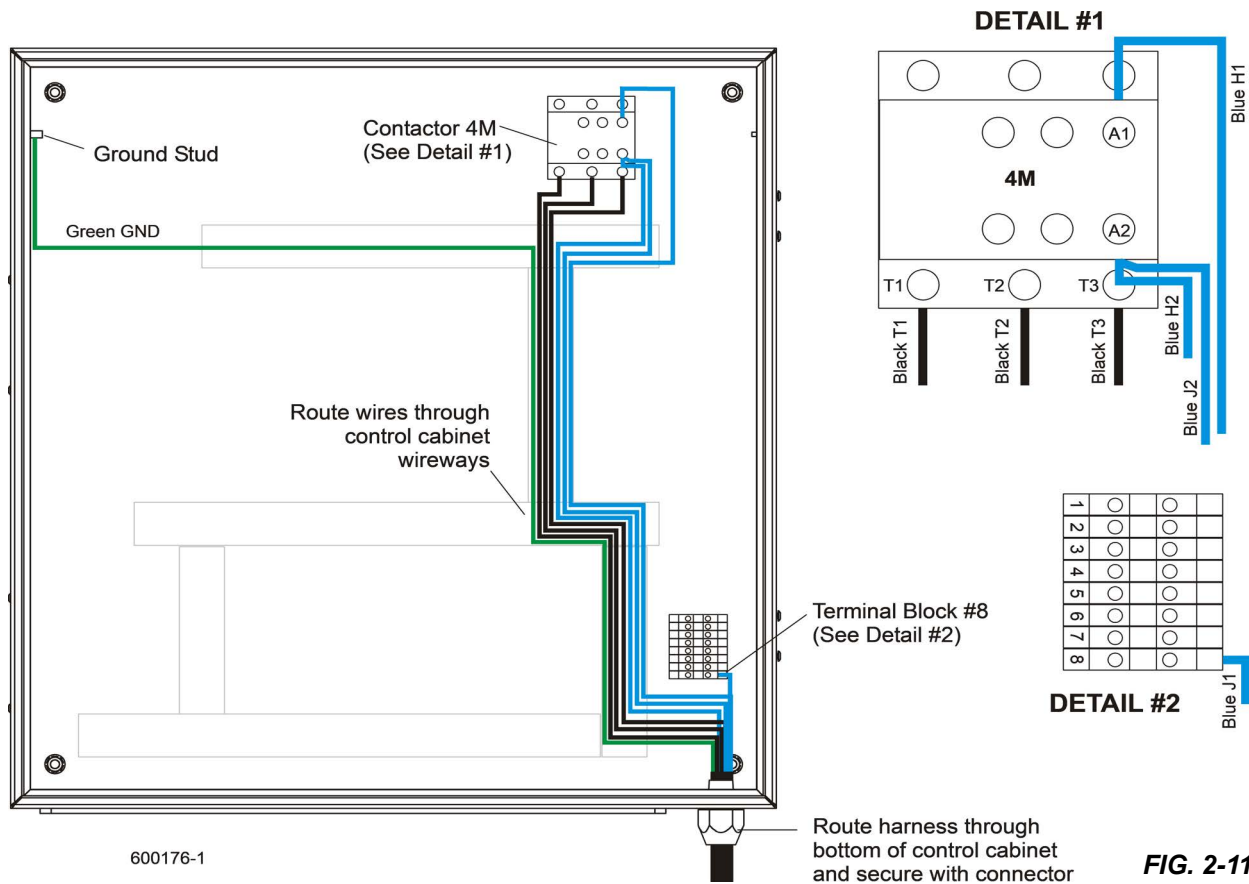

15. Connect the black T1, T2, and T3 wires to the corresponding terminals on the contactor labeled 4M at the top-right corner of the cabinet.
16. Connect the green GND wire to the grounding terminal at the top-left of the control cabinet.
17. Connect the blue H1 wire to the A1 terminal of the 4M contactor.
18. Connect the blue J2 and H2 wires to the A2 terminal of the 4M contactor.
19. Connect the blue J1 wire to empty side of terminal block #8. Replace the wireway covers.

2.3 Control Component Installation (Non-Remote Mills)



DANGER! On electric mills, hazardous voltage inside the disconnect box, starter box, and at the electric motor can cause shock, burns, or death. Disconnect and lock out power! Follow all applicable electrical codes.

DANGER! Before performing any service to this equipment, turn the key to the OFF (0) position, remove the key, and disconnect the sawmill battery ground terminal. Failure to do so will result in serious injury or death.

See [Section 2.4](#) if assembling the Debarker option to a sawmill equipped with the remote operation option. See [SECTION 4](#) for the appropriate wiring diagram to aid in installation.

1. Remove the side, front and rear panels (leave wire connections) from the control box.
2. Locate the solenoid mounting studs in the control box.
3. Place the solenoid on the mounting studs and place the diode assembly ring terminal over one of the studs.
4. Use the two 1/4-20 self-locking nuts provided to secure in place.
5. Remove the two small bolts and nuts and the one large bolt and nut from the back of the control box.
6. Locate the bundle of wires on the floor of the sawmill control box.
7. Make sure the large black #24 wire is connected to the rear ground stud.
8. Connect the large red #23 wire to the empty terminal on the provided 5070 amp breaker.
9. Do not overtighten this connection.

Overtightening could cause component breakage.

10. Install the 70 amp breaker and rubber boot to the large hole on the back of the control box.
11. Be sure the breaker terminals do not touch any other components or wires inside the control box.
12. Install the provided 15 amp breaker to the two small holes in the back of the control box (position the breaker so the reset tab is near the rear opening of the control box).
13. Use the existing screws and nuts (removed earlier) to secure in place.

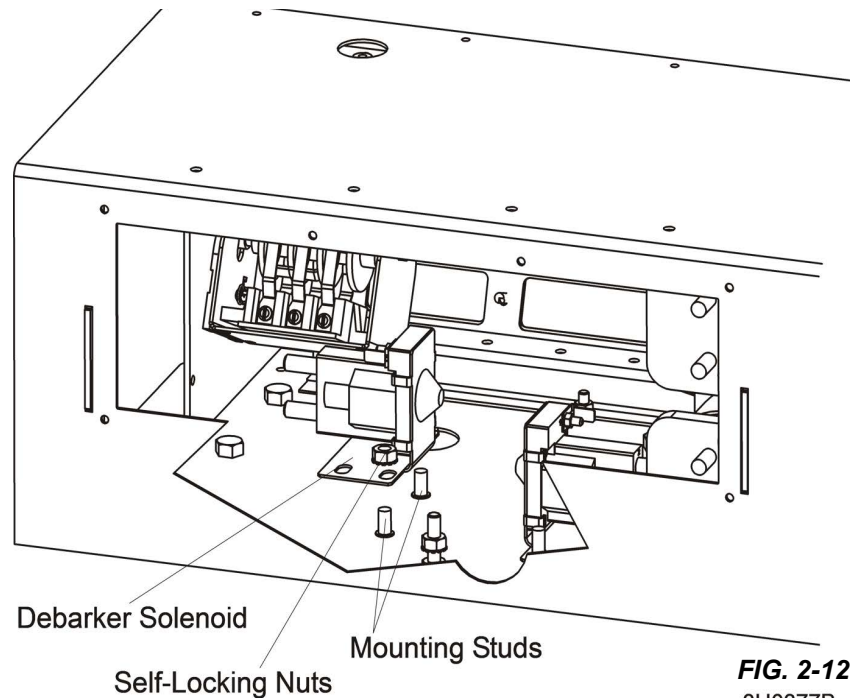

FIG. 2-12
2110273D

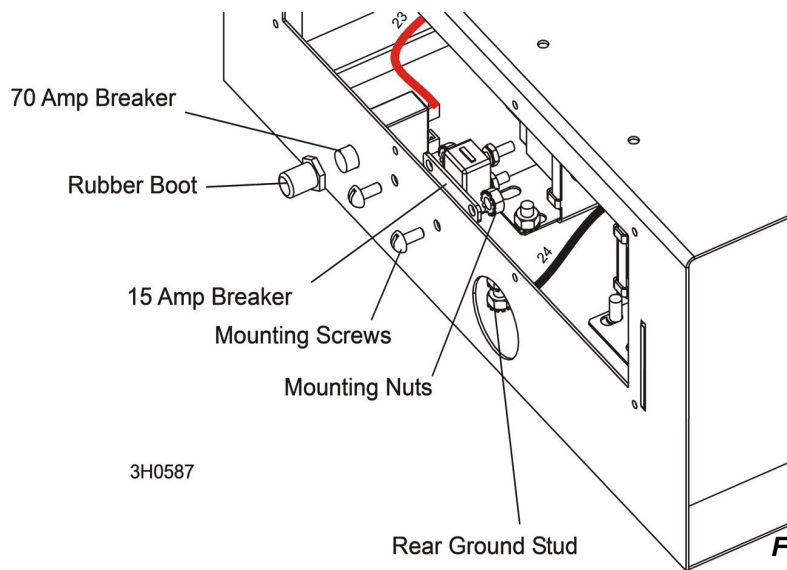

FIG. 2-13

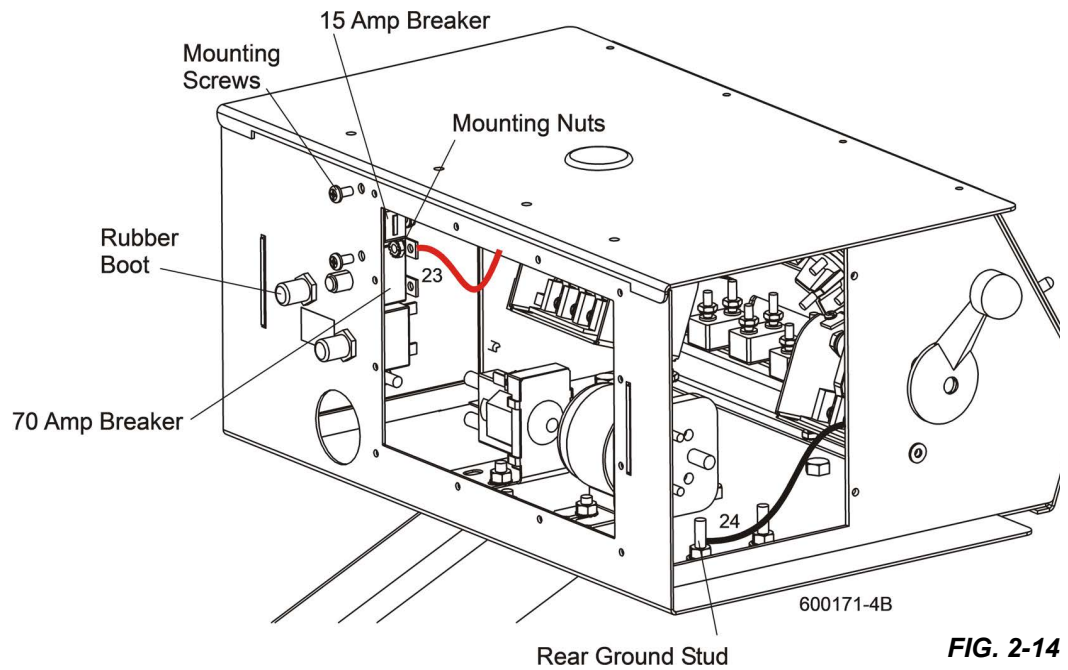

FIG. 2-14

14. Using the back side of the front panel for a guideline, cut out holes in the front panel lexan decal for the debarker switches.
15. Install the provided toggle switches, 1/16" nylon washers, and rubber boots in place as shown.

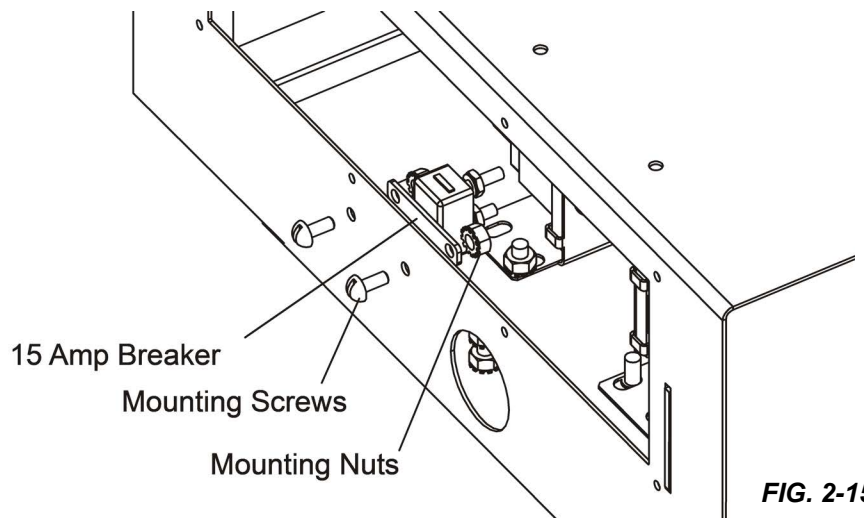
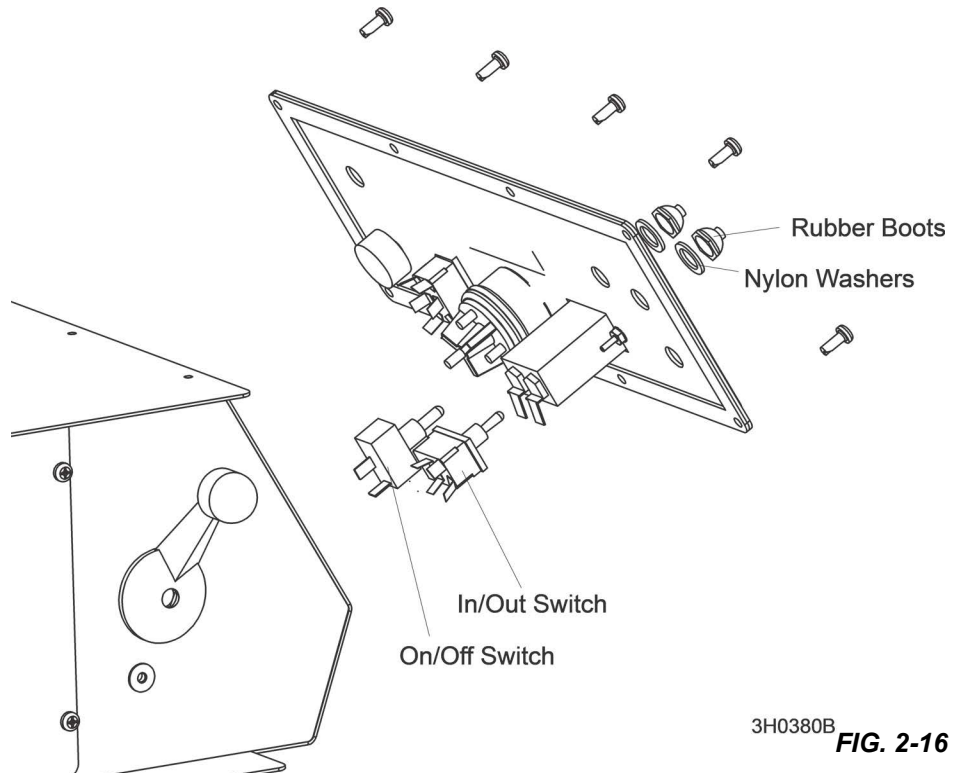

FIG. 2-15



3H0380B **FIG. 2-16**

16. Connect the red #205 wire from the 15 amp breaker to the ACC post on the key switch.
17. Make sure the red #206 wire from the 15 amp breaker to the debarker in/out switch is connected.

Connect the red #202 wire from the debarker solenoid to the DBKR terminal on the LED board. **NOTE:** If the control box is not equipped with the LED board, remove the red #202 wire from the debarker solenoid.

18. Connect the red #208 wire from the debarker on/off switch to the DBKR terminal on the LED board.

NOTE: If the control box is not equipped with the LED board, remove the red #208 wire from the debarker on/off switch.

19. Make sure the red #201 wire from the small terminal on the debarker solenoid to the debarker on/off switch is connected.
20. Connect the red #203 wire from debarker solenoid to the BAT post of the key switch.
21. Make sure the red #204 wire from the bottom debarker solenoid terminal to the 70 Amp breaker is connected.
22. Connect the red #200 wire from the on/off switch to terminal #3 of the existing relay socket in the control box.

Box housing removed for clarity. Only wires referred to above are shown.

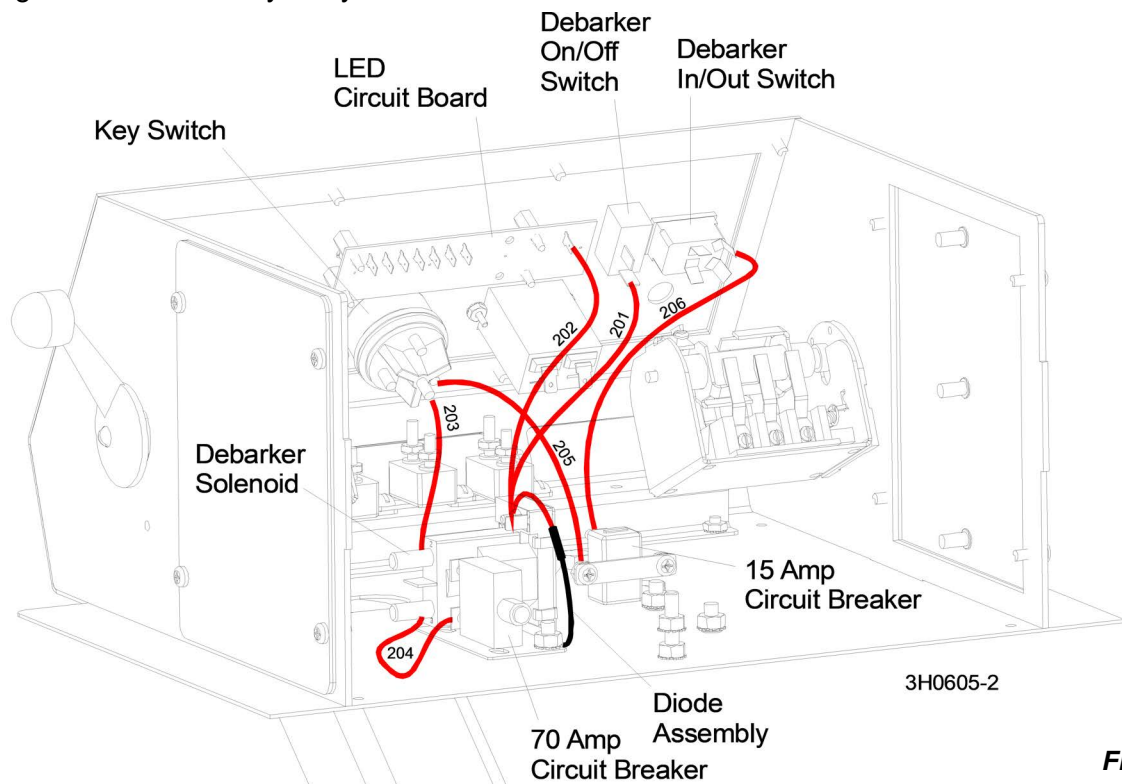

FIG. 2-17

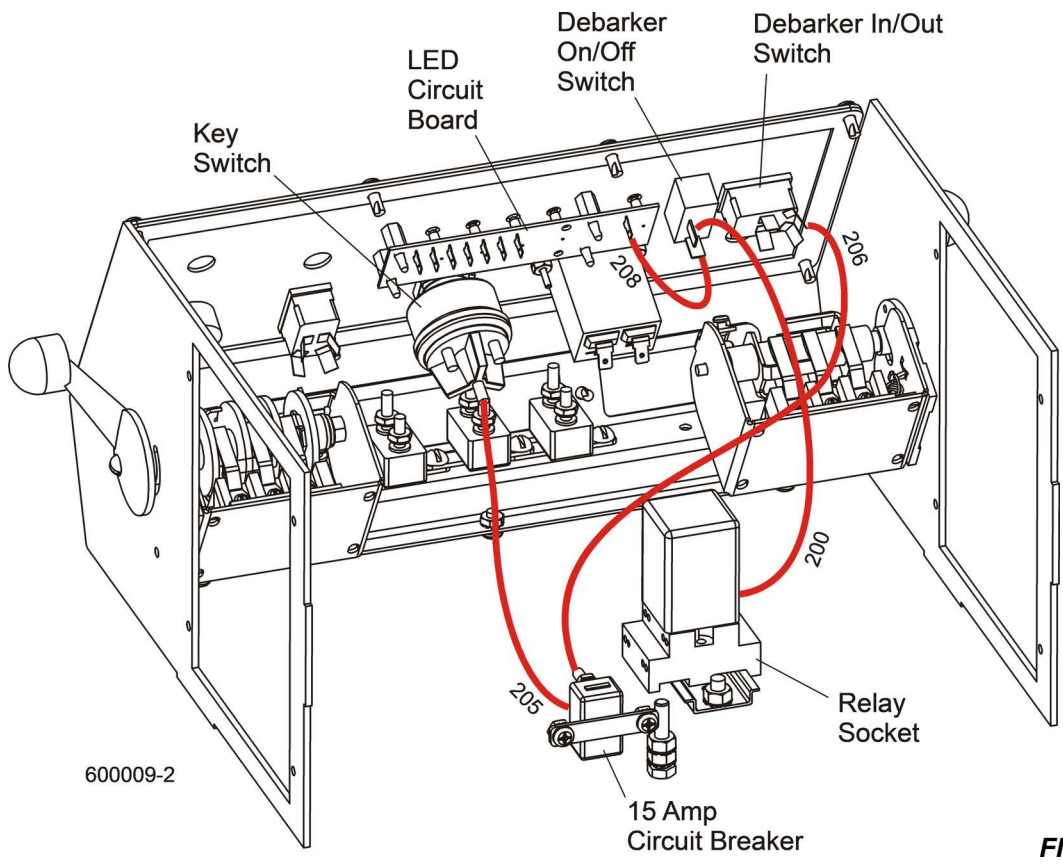

FIG. 2-18

23. Connect the red #200 wire from the debarker on/off switch to the sawmill control:

LT70HD Wireless Models: Connect red wire #200 to the existing short red wire connected to terminal #T13 of the wireless interface control board.

Use the provided #10 screw, washer and lock nut to connect the wires.

Wrap the connection with the provided piece of rubber tubing and secure with a tie wrap.

LT70HD Models between 9/04 and 12/08: Connect red wire #200 to the existing short red wire connected to terminal #3 of the power feed drum switch.

Use the provided #10 screw, washer and lock nut to connect the wires.

Wrap the connection with the provided piece of rubber tubing and secure with a tie wrap.

All LT70HD Models before 9/04 and after 1/09: Connect red wire #200 to terminal #2 of the power feed drum switch.

NOTE: Some sawmills are equipped with a short red wire connected to terminal #2 of the power feed drum switch.

If so, connect debarker wire #200 to the end of the short wire with the provided #10 screw, washer and lock nut.

Wrap the connection with the provided piece of rubber tubing and secure with a tie wrap.

If no short wire exists, connect debarker wire #200 directly to power feed drum switch terminal #2.

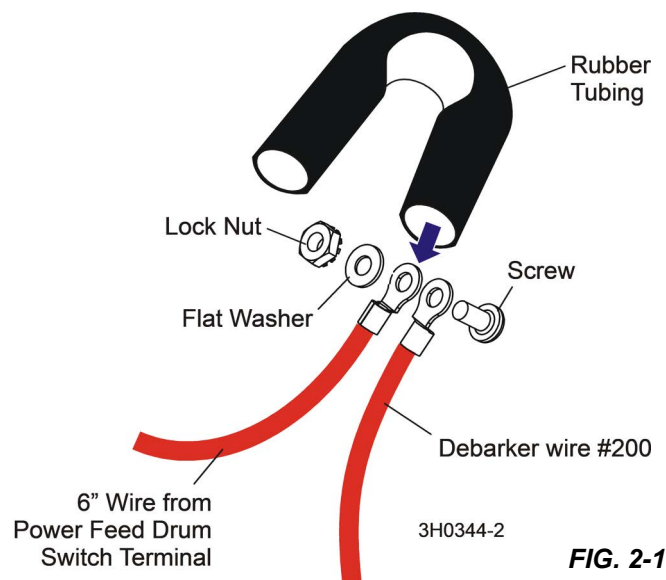

24. Connect the black #207 wire from the debarker in/out switch to the rear ground stud.
25. Locate the bundle of wires on the floor of the sawmill control box.
26. Make sure the debarker in/out switch is oriented horizontally as shown.
27. Connect the small red #21 wire to the debarker in/out switch bottom left terminal.
28. Connect the small black #22 wire to the debarker in/out switch top left terminal.
29. Connect wire #33 (blue on non-remotes, red on remotes) to the bottom debarker on/off switch terminal.

Box housing removed for clarity. Only wires referred to above are shown.

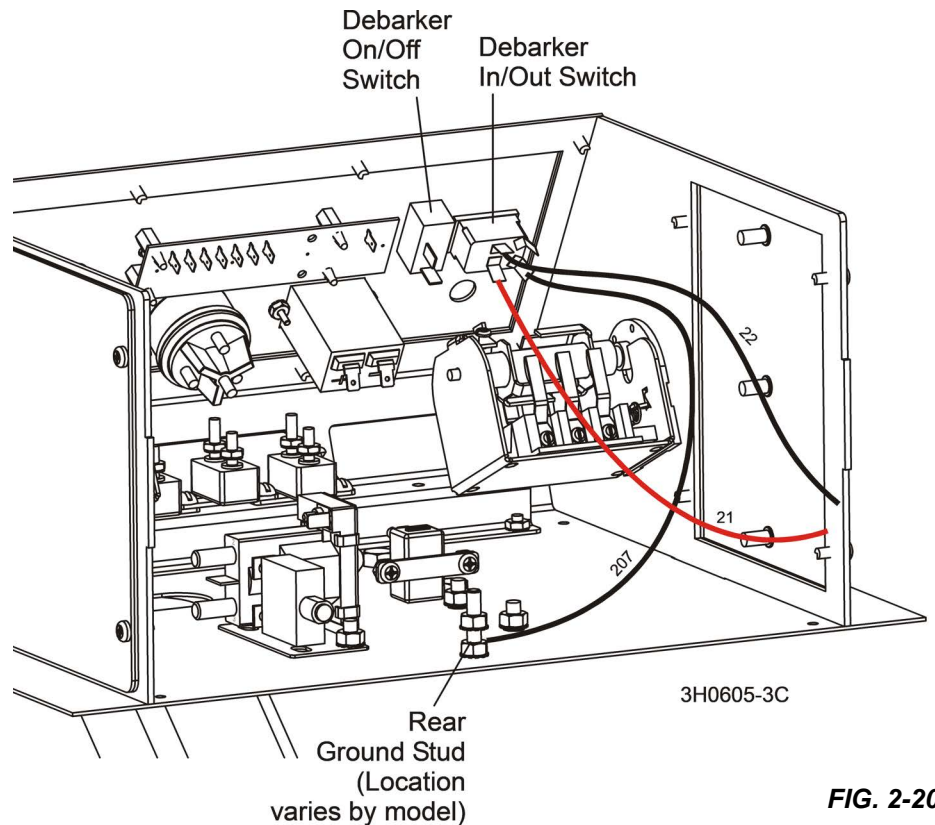

FIG. 2-20

- 30. Reinstall the front and rear panels, side panel, and control box top cover to the control box.

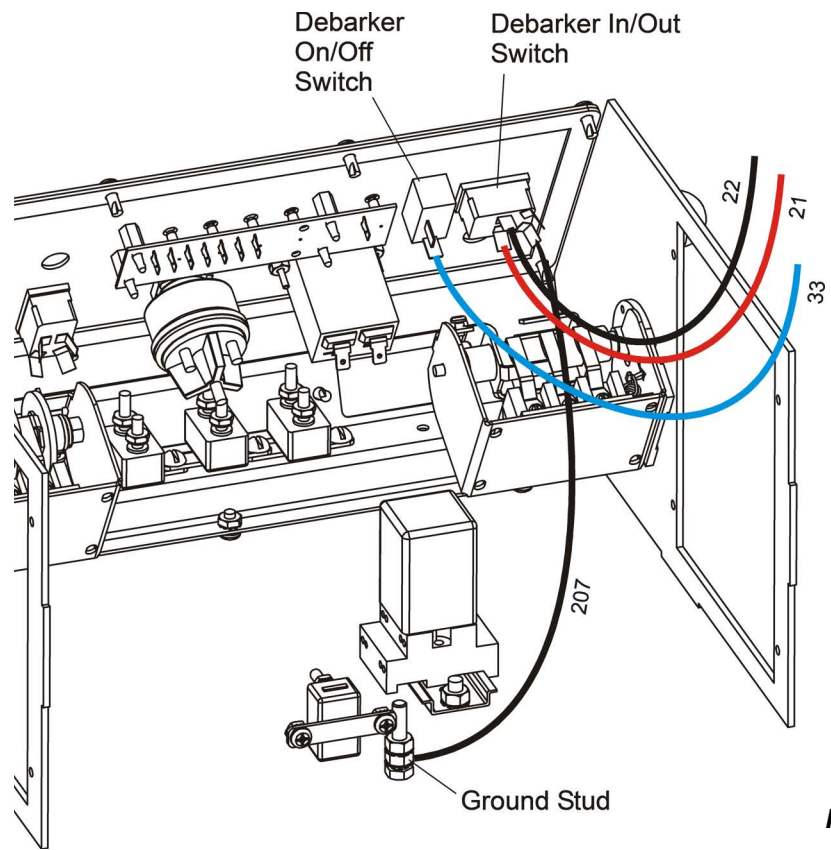

FIG. 2-21

2.4 Control Component Installation (Remote Mills)



DANGER! On electric mills, hazardous voltage inside the disconnect box, starter box, and at the electric motor can cause shock, burns, or death. Disconnect and lock out power! Follow all applicable electrical codes.

DANGER! Before performing any service to this equipment, turn the key to the OFF (0) position, remove the key, and disconnect the sawmill battery ground terminal. Failure to do so will result in serious injury or death.

[See Section 2.3](#) if assembling the Debarker option to a sawmill not equipped with the remote operation option. [See SECTION 5](#) for a complete wiring diagram to aid in installation.

Remote Power Box Component Installation

1. Open the remote power junction box door.
2. Install the debarker solenoid next to the existing solenoid with the two bolts and nuts provided in the bottom of the box.
3. Place the diode ring terminal over one of the solenoid mounting bolts before securing with the nuts.
4. Locate the large red #23 wire in the remote power box and connect it to the empty terminal on the provided 70 Amp breaker.
5. Do not overtighten this connection. Overtightening could cause component breakage.
6. Remove the bolt and nut from the hole in the side of the remote power box and install the 70 Amp breaker and rubber boot to the hole.
7. Be sure the breaker terminals do not touch any other components or wires inside the control box.
8. Make sure the large black #24 wire is connected to the side ground stud.
9. Locate the small red #33 wire from connector J1 terminal #16J2 terminal #18.
10. Connect it to the small, top terminal on the debarker solenoid.
11. Connect large red #203 wire from the large bottom terminal of the debarker solenoid to the accessory solenoid:
100A Solenoid before 5/03: Connect red wire #203 to the large bottom terminal.
200A Solenoid after 5/03: Connect red wire #203 to the large terminal closest to the debarker solenoid.

Only wires referred to above are shown.

12. Close the remote power box door.
13. Engage the door latch and tighten with a hex key to properly seal the box.

Sawmill Control Box Component Installation

14. Remove the rear panel from the sawmill control box (leave wire connections).
15. Remove the two small bolts and nuts from the back of the control box.

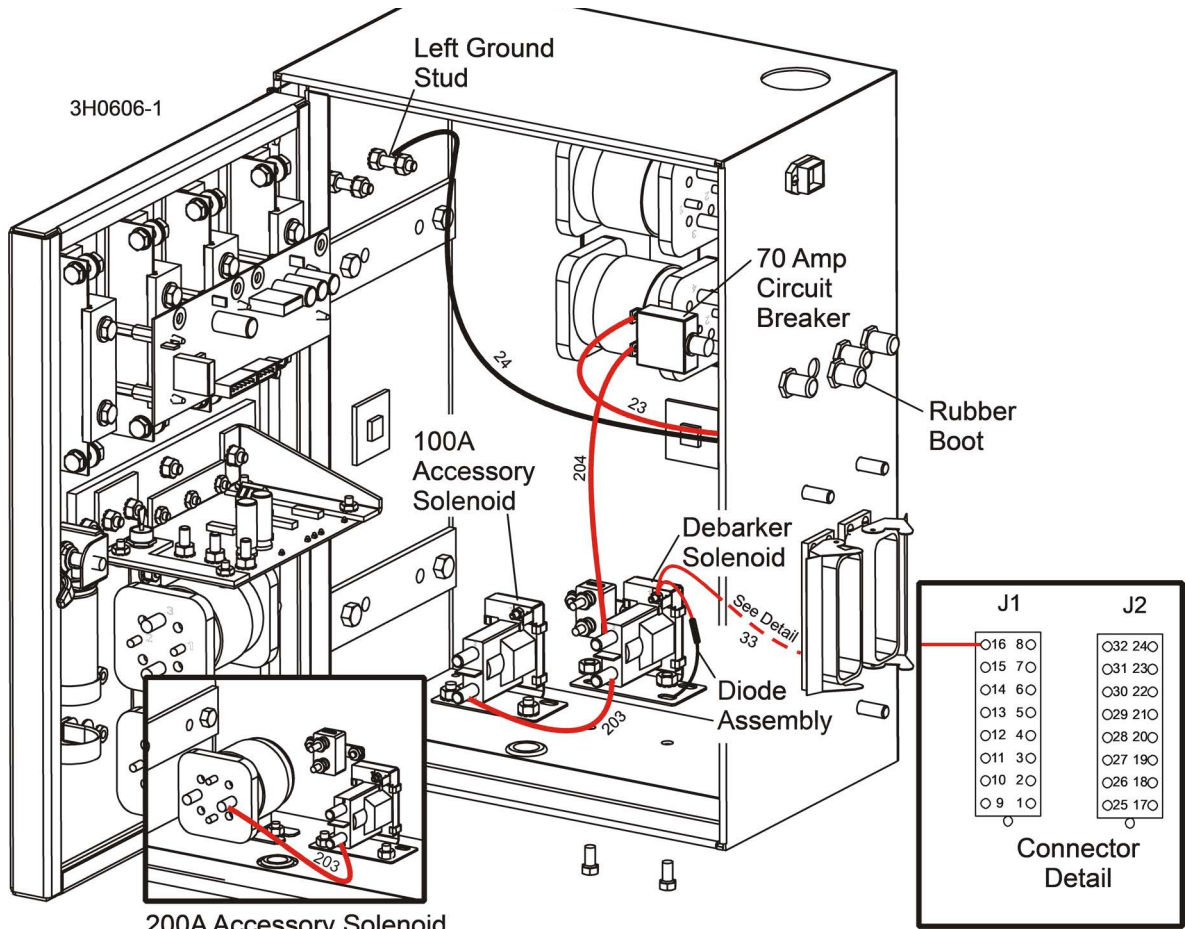

FIG. 2-22

16. Install the provided 15 Amp breaker to the two small holes in the back of the control box (reset tab up).
17. Replace the screws and nuts to secure the breaker to the back panel.
18. Using the back side of the front panel for a guideline, cut out holes in the front panel lexan decal for the debarker switches.

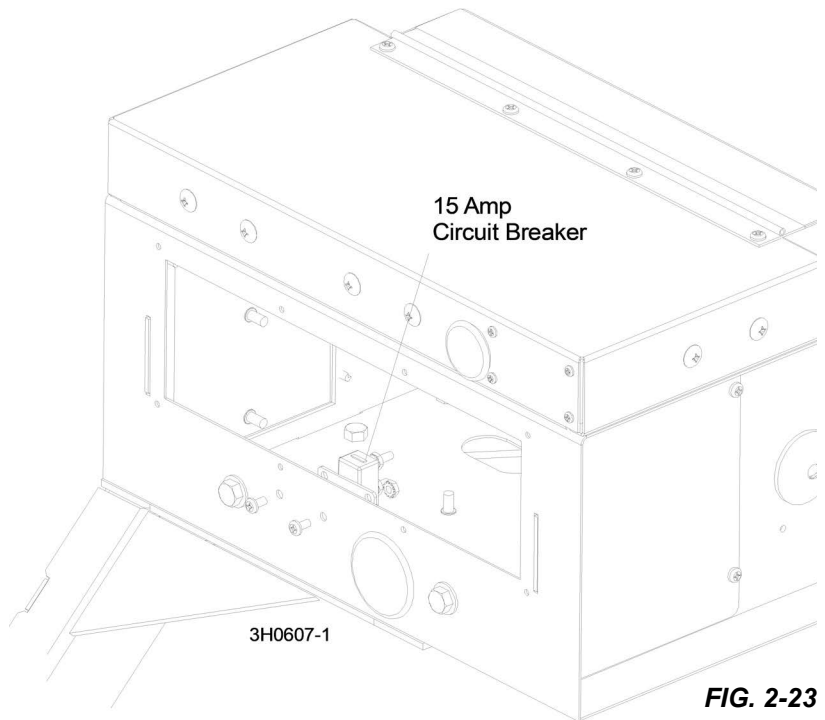
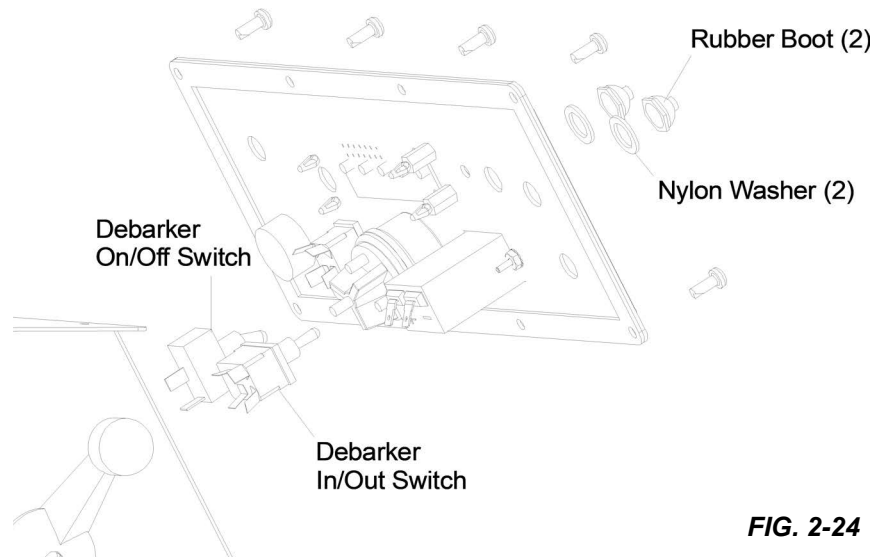

FIG. 2-23

19. Install the provided toggle switches, 1/16" nylon washers, and rubber boots in place as shown.
20. Connect the red #205 wire from the 15 Amp breaker to the ACC post on the key switch.
21. Make sure the red #206 wire from the 15 Amp breaker to the debarker in/out switch is connected.
22. Connect the red #208 wire from the debarker on/off switch to the DBKR terminal on the LED board.

NOTE: If the control box is not equipped with the LED board, remove the red #208 wire from the debarker on/of switch.

**FIG. 2-24**

Box housing removed for clarity. Only wires referred to above are shown.

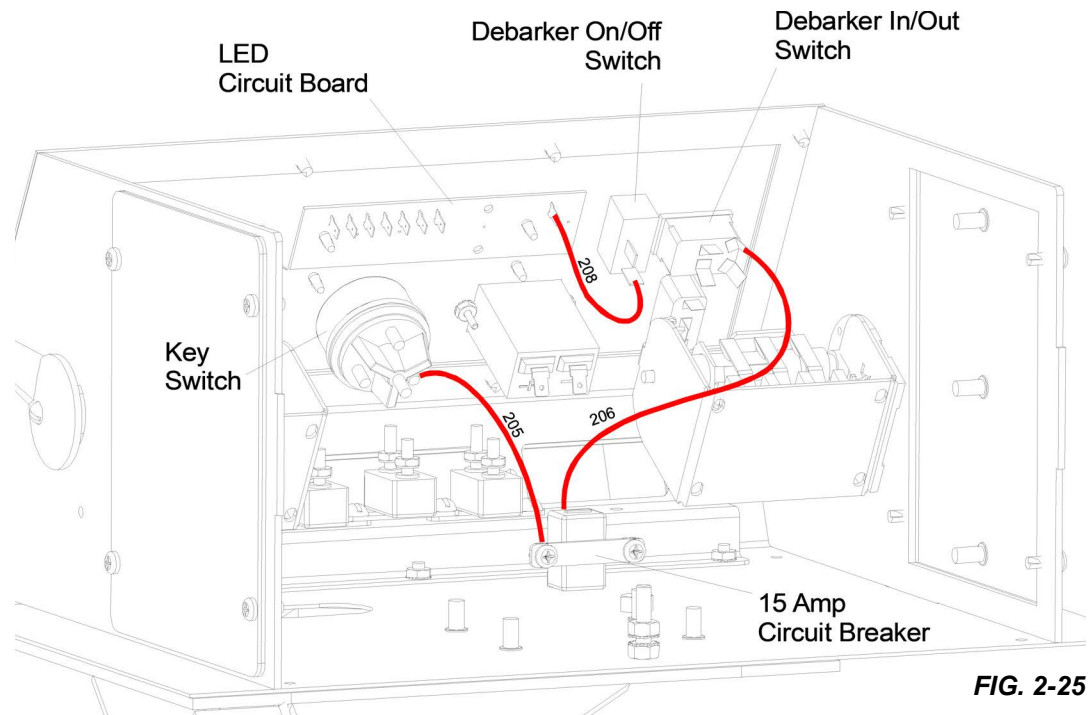
**FIG. 2-25**

23. Connect the red #200 wire from the debarker on/off switch to the power feed drum switch.

LT60HD/70HD Models after 9/04: Connect red wire #200 to the existing short red wire connected to terminal #3 of the power feed drum switch.

Use the provided #10 screw, washer and lock nut to connect the wires.

Wrap the connection with the provided piece of rubber tubing and secure with a tie wrap.

All LT60HD/70HD Models before 9/04: Connect red wire #200 to terminal #2 of the power feed drum switch.

NOTE: Some sawmills are equipped with a short red wire connected to terminal #2 of the power feed drum switch.

If so, connect debarker wire #200 to the end of the short wire with the provided #10 screw, washer and lock nut.

Wrap the connection with the provided piece of rubber tubing and secure with a tie wrap.

If no short wire exists, connect debarker wire #200 directly to power feed drum switch terminal #2.

24. Connect the black #207 wire from the debarker in/out switch to the rear ground stud.

25. Locate the bundle of wires on the floor of the sawmill control box. Make sure the debarker in/out switch is oriented horizontally as shown.

26. Connect the small red #21 wire to the debarker in/out switch bottom left terminal.

27. Connect the small black #22 wire to the debarker in/out switch top left terminal.

28. Connect the small red #33 wire to the male terminal extension on the debarker on/off switch bottom terminal.

29. Reinstall the control box panels.

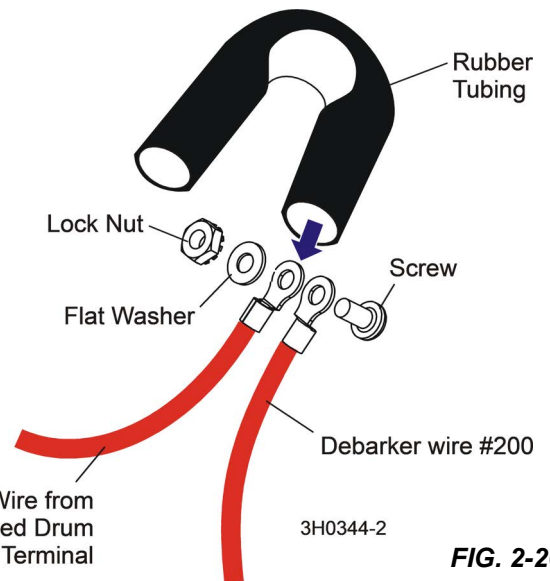

FIG. 2-26

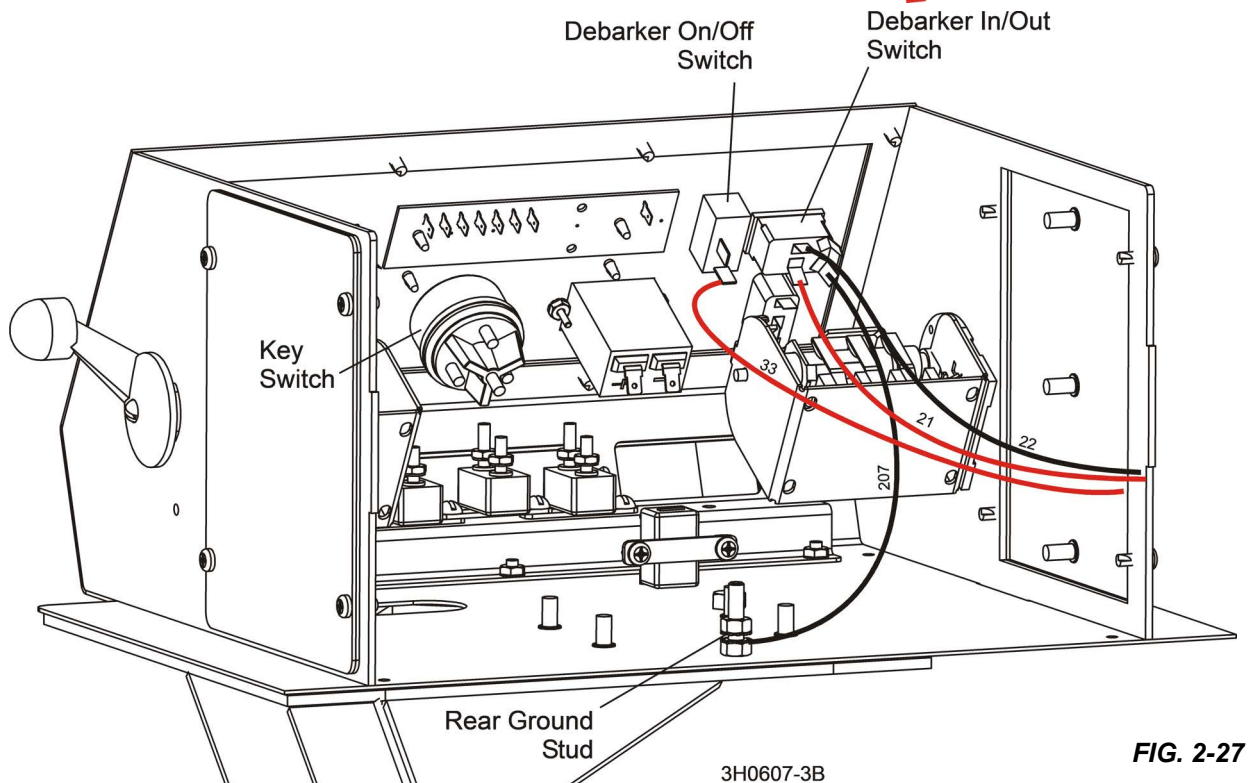

FIG. 2-27

SECTION 3 ALIGNMENT

3.1 Debarker Alignment



DANGER! Before performing any service to this equipment, turn the key to the OFF (0) position and remove the key. Failure to do so will result in serious injury or death.

The debarker blade should be aligned to the sawmill blade to insure proper operation. The debarker blade should be parallel with and aligned vertically with the sawmill blade.

1. Turn the key to ACC (3) and use the debarker in/out switch to move the debarker all the way in.
2. Turn the key to OFF (0) and remove the key to prevent the debarker from being turned on while performing alignment procedures.
3. Check the squareness of the debarker with the sawmill blade.
4. Adjust the debarker mounts if necessary until the debarker is square with the sawmill blade.
5. Loosen the bottom debarker mounting bolt and loosen the jam nuts on the adjustment bolts.
6. Turn the adjustment bolts as necessary until the debarker is square with the sawmill blade.
7. Retighten the jam nuts and bottom debarker mounting bolt.
8. Clip the blade guide alignment tool to the sawmill blade.
9. Make sure the tool lies flat on the blade and does not contact a tooth that could cause it to angle.

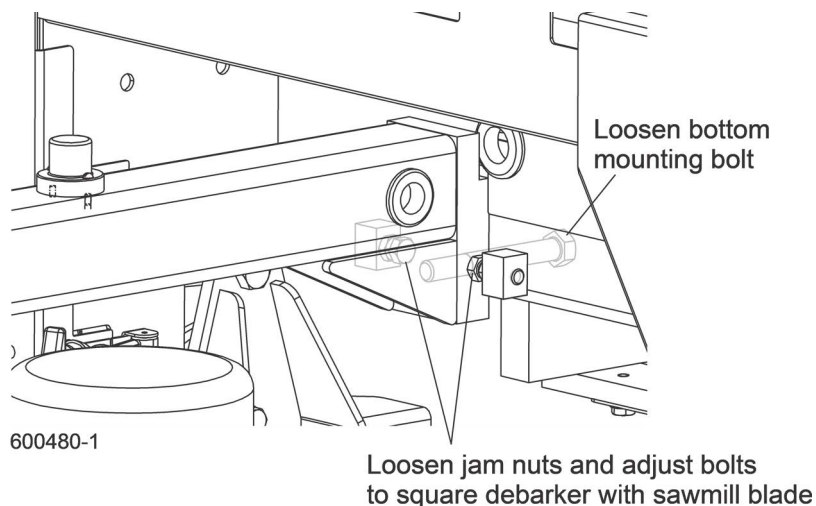

FIG. 3-1

10. Check the height of the debarker blade against the alignment tool.
11. The bottom edge of the tool should align with the center of the debarker blade.
12. To adjust the blade up or down, loosen the four blade motor mount bolts. Loosen the jam nut on the adjustment bolt. Turn the adjustment bolt clockwise to push the motor and blade down. Turn the adjustment bolt counterclockwise and slide the motor up to raise the motor and blade. Retighten the adjustment bolt jam nut and four motor mount bolts.
13. Insert the key and use the debarker in/out switch to move the debarker all the way out.
14. Turn the key to OFF (0) and remove the key.
15. Move the blade guide alignment tool on the sawmill blade and check the position of the debarker blade against the tool.
16. If the debarker blade is not centered with the tool, readjust the debarker mounting bolts to adjust the debarker assembly parallel to the blade.

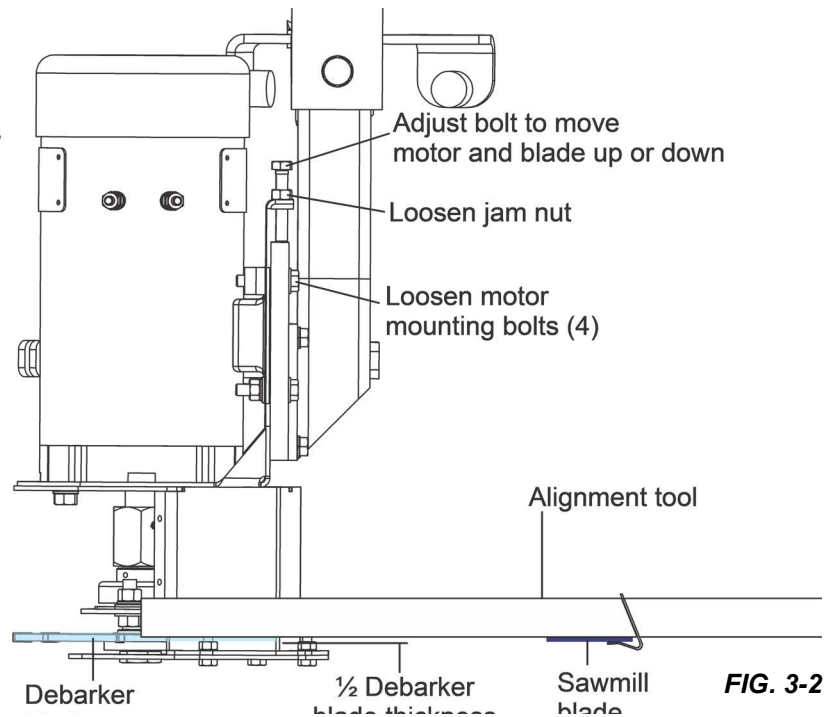

FIG. 3-2

SECTION 4 OPERATION AND MAINTENANCE

4.1 Debarker Travel Lock Pin

The debarker is equipped with a travel lock pin. Insert the lock pin to lock the debarker in place when towing the sawmill. Remove the lock pin to unlock the debarker while the debarking is required during sawing.

Before operating the debarker, make sure the lock pin is secured in its travel position. Turn the key switch to OFF (0) and remove the key. Pull the debarker out to relieve pressure on the lock pin. Remove the lock pin.

Before towing the sawmill, lock the debarker in the travel position. Turn the key switch to ACC (3) and use the debarker in/out switch to move the debarker all the way in. Turn the key to OFF (0) and remove the key. Push the debarker in until the travel position holes align. Insert the lock pin.

To move the debarker out of the way during sawing, turn the key switch to ACC (3) and use the debarker in/out switch to move the debarker all the way out.

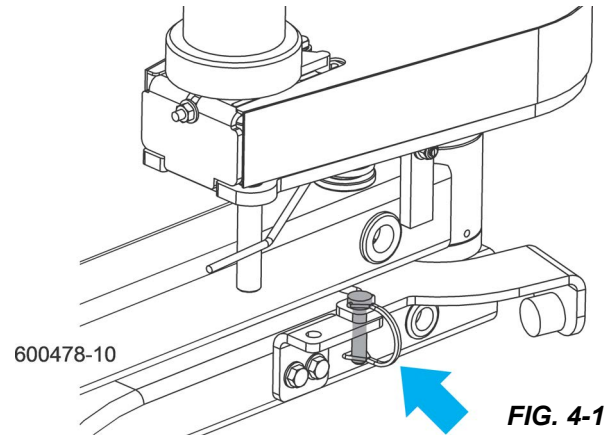

4.2 Control Overview

The Debarker Option allows you to remove bark from logs ahead of the bandsaw blade. This prevents the bandsaw blade from contacting dirt, sand, or other debris in the bark that can dull the blade.

The debarker control includes two toggle switches, an indicator light, and circuit breakers with manual reset.

The debarker control includes two toggle switches and an indicator light.

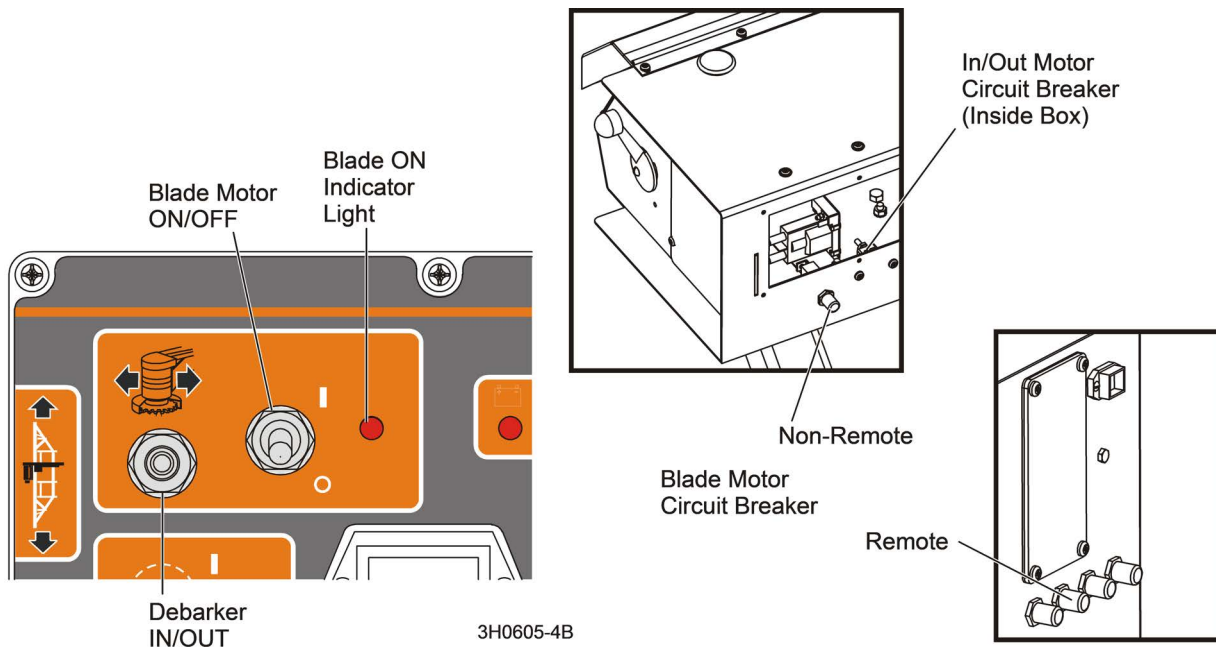

FIG. 4-2

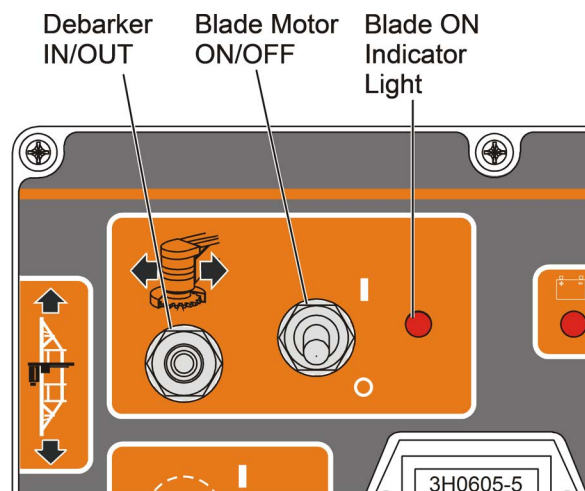

FIG. 4-3

- The Debarker IN/OUT toggle switch controls the debarker in/out motor to move the debarker saw head toward or away from the log. The sawmill key switch must be on before the in/out function can be performed. **NOTE:** The distance between the debarker blade and the side support with the saw head all the way in is 6" (150mm) for the sawmill equipped with the standard head and 12" (300mm) for the sawmill equipped with the wide head.

- The Blade Motor ON/OFF toggle switch turns the blade motor on to start the debarker blade. The sawmill key switch must be on and the sawmill power feed drum switch must be activated in the forward direction before the blade motor can be turned on.
- The Blade ON indicator light comes on whenever the debarker blade motor is on.
- **Non-Remote Sawmills:** The blade motor circuit breaker can be reset by pushing the boot-covered tab on the back of the control box.
- **Remote Sawmills:** The blade motor circuit breaker can be reset by pushing the boot-covered tab on the side of the remote power box.

4.3 Operation



DANGER! Make sure all guards and covers are in place and secured before operating the debarker option. Failure to do so may result in serious injury.

DANGER! Keep all persons out of the path of moving equipment when operating the debarker. Failure to do so will result in serious injury.

1. Remove the blade motor cover before operating the debarker.
2. Make sure the warning light is on when the debarker is turned on.



WARNING! Debarker is ON when warning light is on. **DO NOT** disconnect the warning light. Doing so may result in serious injury.

3. Use the in/out switch on the control box to pivot the debarker all the way out.
4. Move the sawmill carriage forward and pivot the debarker in until the front fence engages with the end/side of the log.
5. Turn the debarker on/off switch to ON (1).
6. Proceed with cutting. The actuator will keep the debarker against the side of the log. Depending on log shape, you may have to pivot the debarker in and out for smooth cutting.

NOTE: The debarker can continuously remove up to approximately 1" of material from the log; no motor cool down time is required. Slower feed rates may be required for optimal debarker operation.

7. Once the carriage is past the end of the log, pivot the debarker away from the log. Return the carriage.

IMPORTANT! Should the carriage be returned before the debarker has been pivoted out of the way of the log, the debarker is designed to pivot upwards. If this happens, continue to **SLOWLY** return the carriage; or stop, pivot the debarker out and then return the carriage. **DO NOT** move the carriage forward while the debarker is contacting the log without the blade spinning.

8. When done sawing and ready to store or transport the sawmill, replace the debarker blade motor cover. Place the debarker in its travel position before towing the sawmill ().

4.4 Maintenance



DANGER! Before performing any service to this equipment, turn the key to the OFF (0) position and remove the key. Failure to do so will result in serious injury or death.

1. Lubricate the pivot joint with a NLGI #2 grade lithium grease every 40 hours of operation.
2. Periodically check the flexible guard.
3. Adjust the guard up or down so the bottom is even with the bottom of the debarker blade.
4. Replace the guard as needed.
5. Periodically check the debarker blade.
6. Align or replace as needed.



WARNING! Before replacing the debarker blade, move the sawmill blade guide arm in front of the sawmill blade to cover the blade teeth. Failure to do so may result in serious injury or death.

1. To replace the debarker blade,
2. remove the lower blade guard plate.
3. Place one wrench on the blade arbor, above the blade bearing.
4. Place the other wrench on the lower bolt and rotate clockwise (bolt has left-hand threads).
5. Remove the bolt and washer. Remove the blade and spacer.
6. Reinstall the spacer with the new blade.
7. Reinstall the bolt and washer and turn counterclockwise to tighten to 35 foot-pounds (± 5).
8. Reinstall the blade guard plate.



CAUTION! Tighten the blade bolt manually. Using power-assisted tools may result in over-torquing and damage to the bolt.

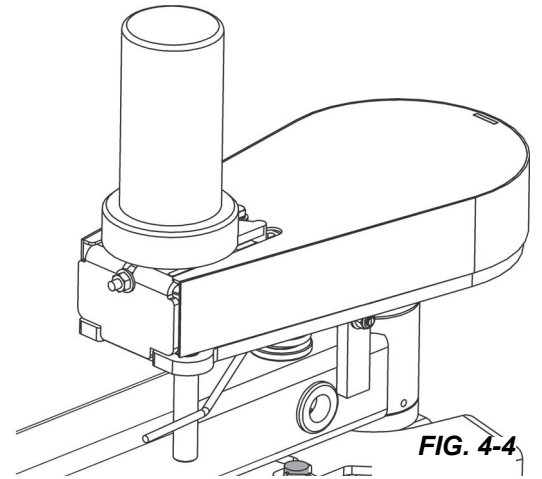

FIG. 4-4

4.5 Debarker Troubleshooting



DANGER! Before performing any service to this equipment, turn the key to the OFF (0) position, remove the key, and disconnect the sawmill battery ground terminal. Failure to do so will result in serious injury or death.

PROBLEM	CAUSE	SOLUTION
70 amp circuit breaker tripping	Wood or bark jammed in blade guard	Turn key to OFF position, remove key. Remove wood or bark from blade guard
	Pivot pin is binding.	Inspect for bind by moving debarker head to full in position. Turn key to OFF position, remove key. Pull arm to full out position by hand. If available, use a weight scale to pull arm to full out position. Should not have more than 12 pounds of resistance to pull out. Ensure pivot pin has been greased properly. Check pivot clamps for correct installation. Loosen pivot clamp bolts slightly, check for reduced binding
	Ring terminal of red wire touching debarker motor housing at motor	Move terminal away from motor housing. Reset circuit breaker and retest.
Light comes on, but debarker motor and warning light do not operate	Circuit breaker weak from repeated tripping.	Replace circuit breaker
	Circuit breaker tripped	Reset circuit breaker.
Debarker shuts off, but the circuit breaker is not tripped.	Bad ignition wire connection	Check ignition wire connection outside and inside of debarker control box.
	Intermittent key switch	Replace key switch
	Other loose wiring connection	Check wiring connections inside control box.
Debarker will not shut off.	Solenoid is stuck closed.	Replace solenoid.
IN/OUT Motor does not move IN or OUT	Drive belt too loose	Tighten enough to allow movement. DO NOT OVER-TIGHTEN.
	Switch not working properly	Check wiring to switch for loose connections. If wiring looks OK, replace switch.

SECTION 5 ELECTRICAL INFORMATION

5.1 Debarker Electrical Symbol Diagram (Non-Remote)

LT60/70: Fwd/Rev Drum Switch Term. 2 (pre-SoftStart PF before 9/04 and Dual-Axis Accuset 2 1/09+)
 LT60/70: Fwd/Rev Drum Switch Term. 3 (SoftStart PF 9/04 - 12/08)
 All Super: Fwd/Rev Drum Switch Term. 3 (SoftStart PF 9/04 - 7/10)
 All Super: Fwd/Rev Drum Switch Term. 2 (pre-SoftStart PF before 9/04 and Dual-Axis Accuset 2 8/10+)
 Std. LT30/40: Fwd/Rev Drum Switch Term. 2
 LT40HD-H Hydro: Relay L13 Term. 87

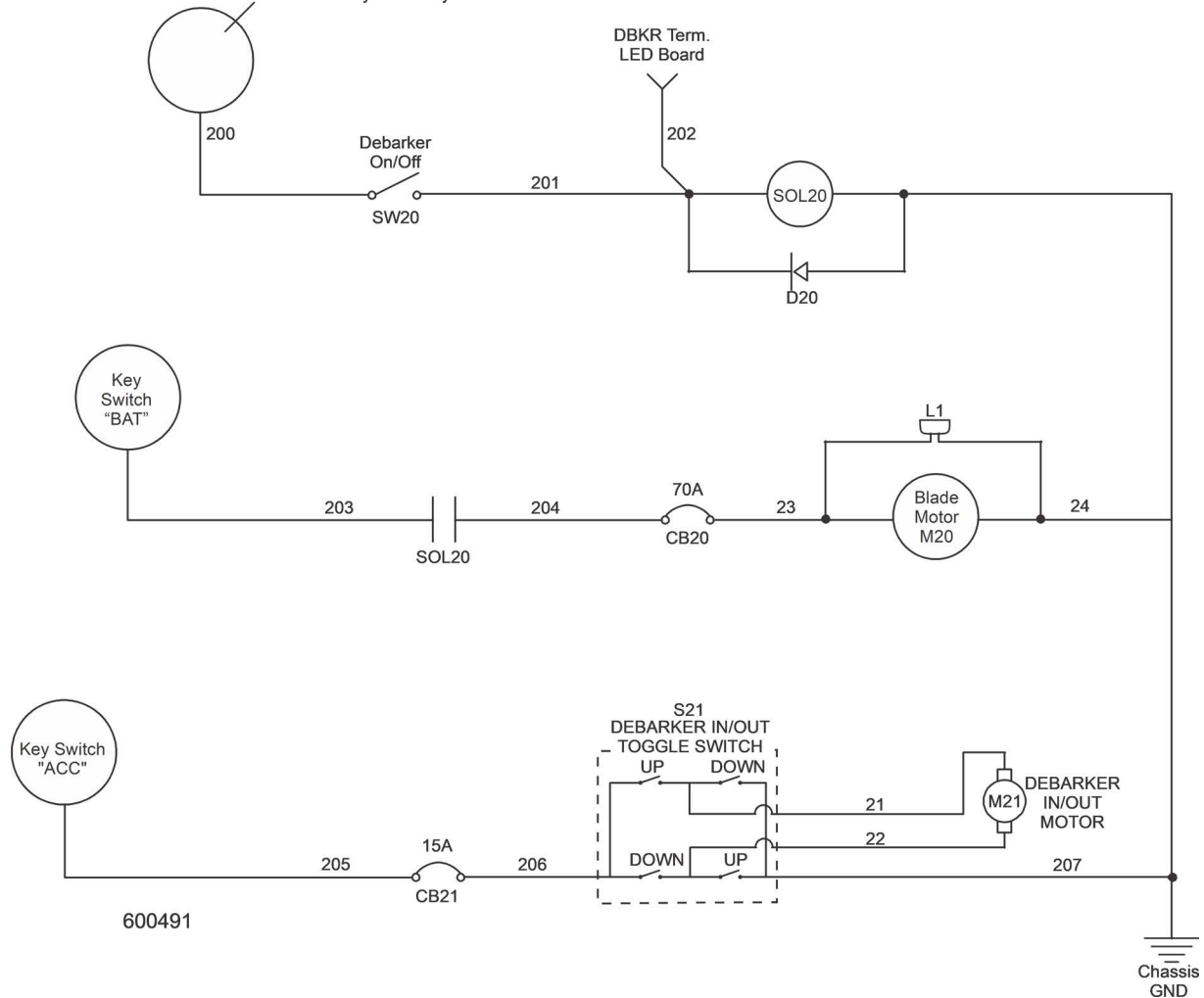

FIG. 5-1 NON-REMOTE SAWMILL

Low Voltage

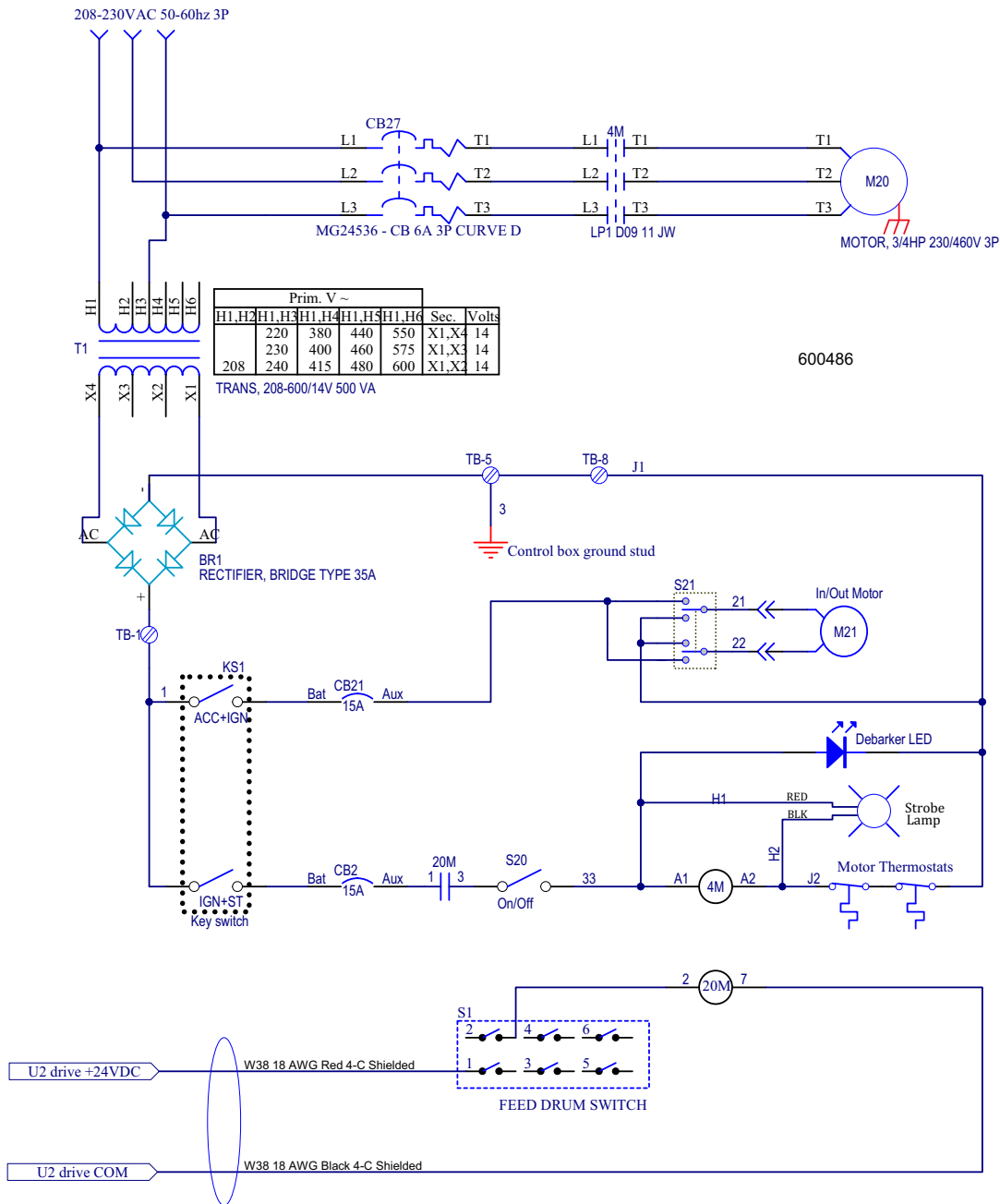

FIG. 5-2

High Voltage

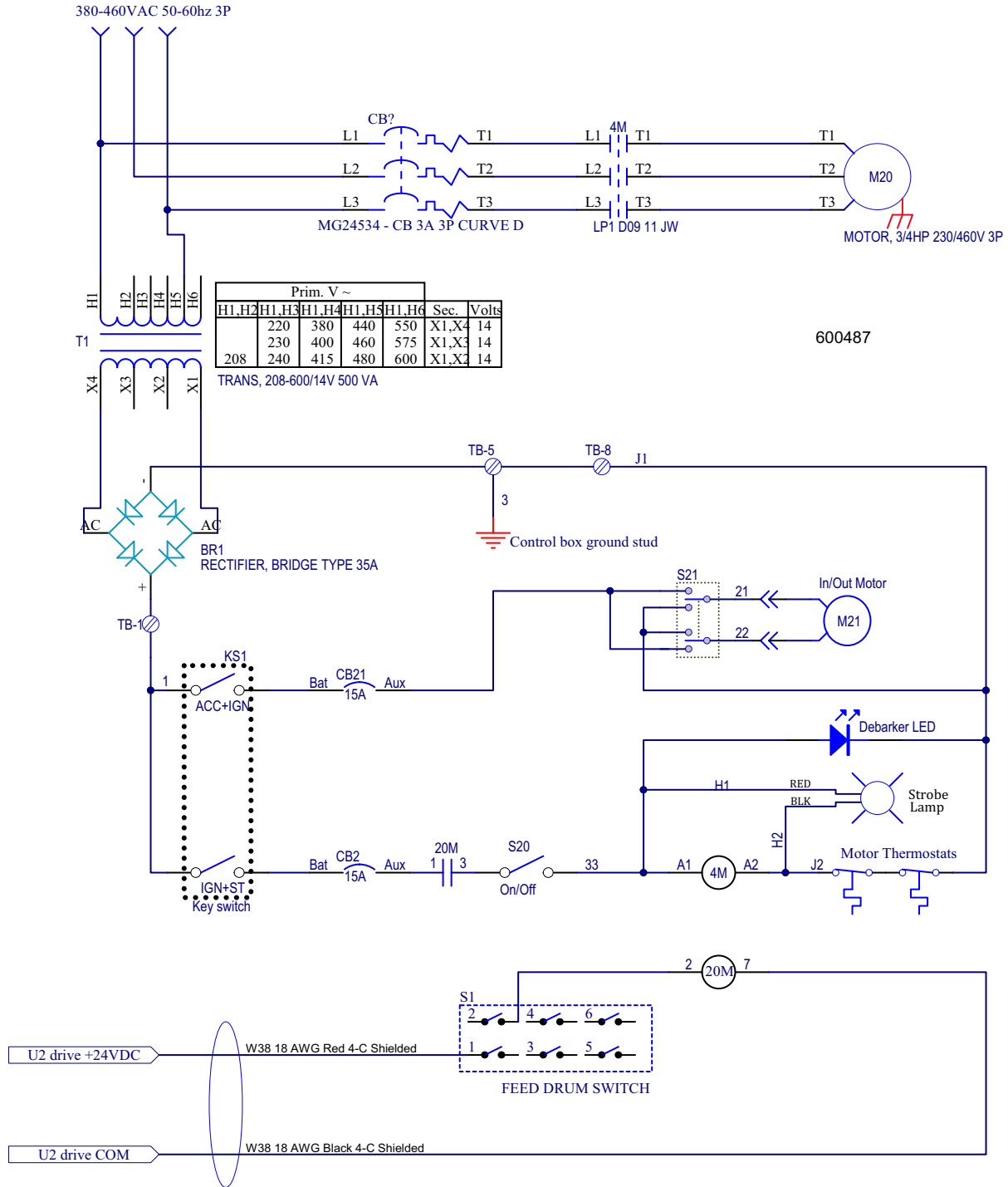

FIG. 5-3

5.2 Debarker Electrical Symbol Diagram (Remote)

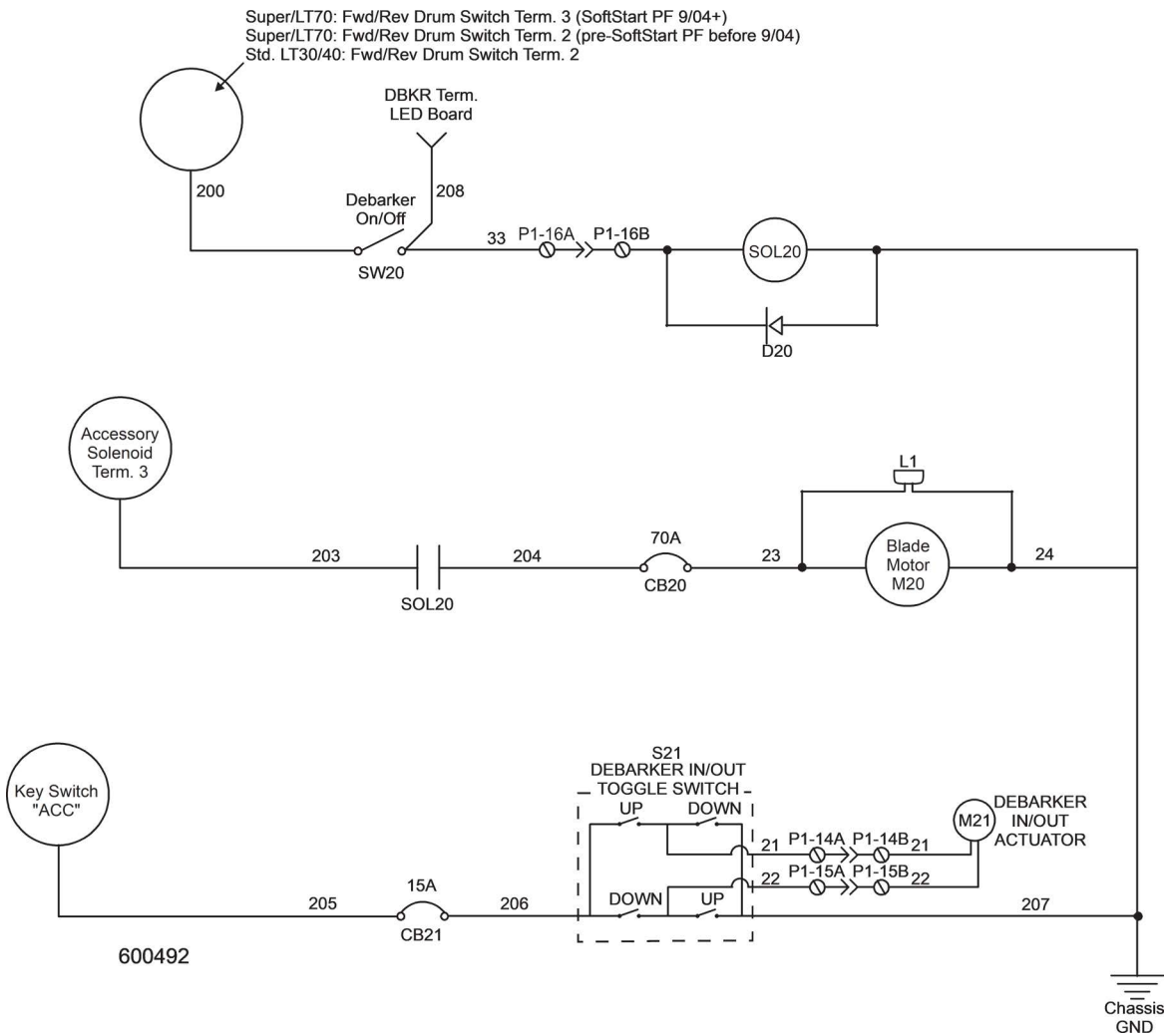

FIG. 5-4 REMOTE SAWMILL

Low Voltage

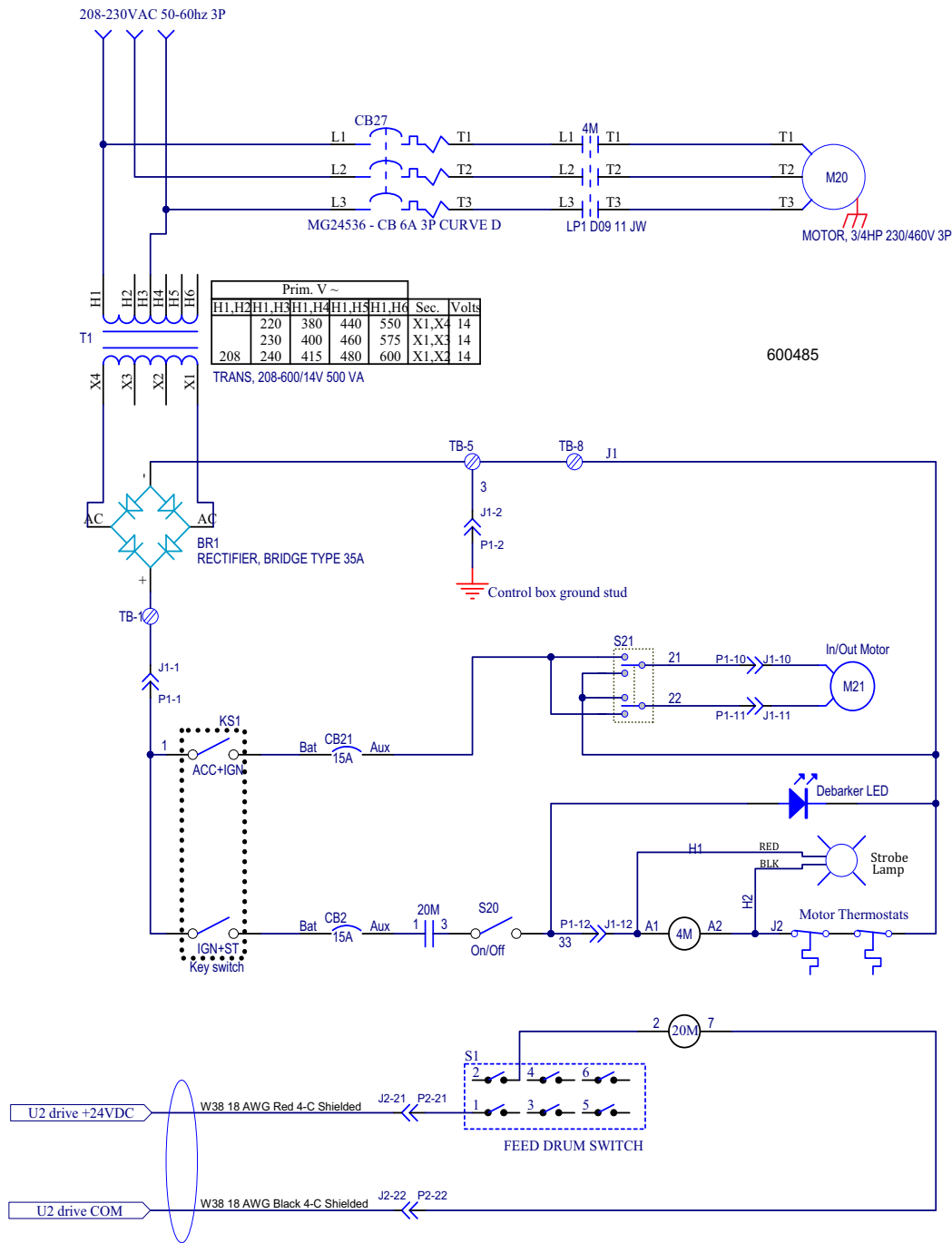

FIG. 5-5

High Voltage

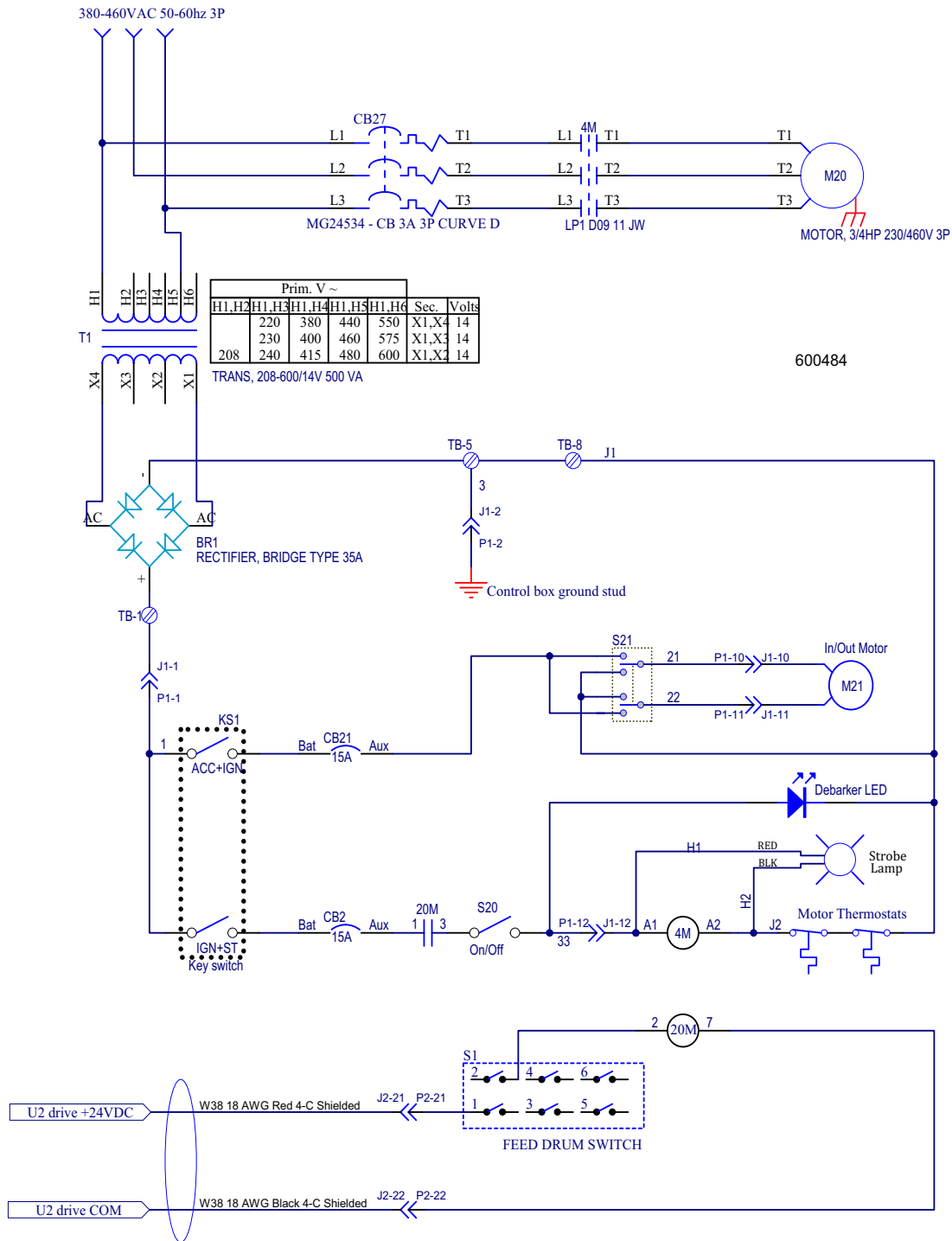

FIG. 5-6

5.3 Debarker Electrical Component List

ID	Wood-Mizer Part No.	Description
CB20	015527	Breaker, 70 A Manual Reset Panel Mount Circuit
CB21	E20430	Breaker, 15 Amp
D20	015426	Diode Assembly, Solenoid Coil Chassis
L1	073555	Light Assembly, Debarker ON Warning Strobe
M20	023688	Motor, 12 V DC 3/4HP TEFC W/Base 7/8" Dia. Shaft
M20	050292	Motor, 3/4HP 230/460 3P 1725RPM
M21	074826	Gearmotor Assembly, LT70 Debarker In/Out
SOL20	016372	Solenoid, 12V 100A Cont Duty GND Coil
S20	P03027	Switch, Toggle
S21	024200	Switch, DPDT Toggle

5.4 Debarker Electrical Wiring Diagram (non-Remote Sawmills)

LT70HDRev. B6.07+

This diagram applies to non-Remote LT60HD/70HD model sawmills built after 1/09 with dual-axis Accuset 2 system.

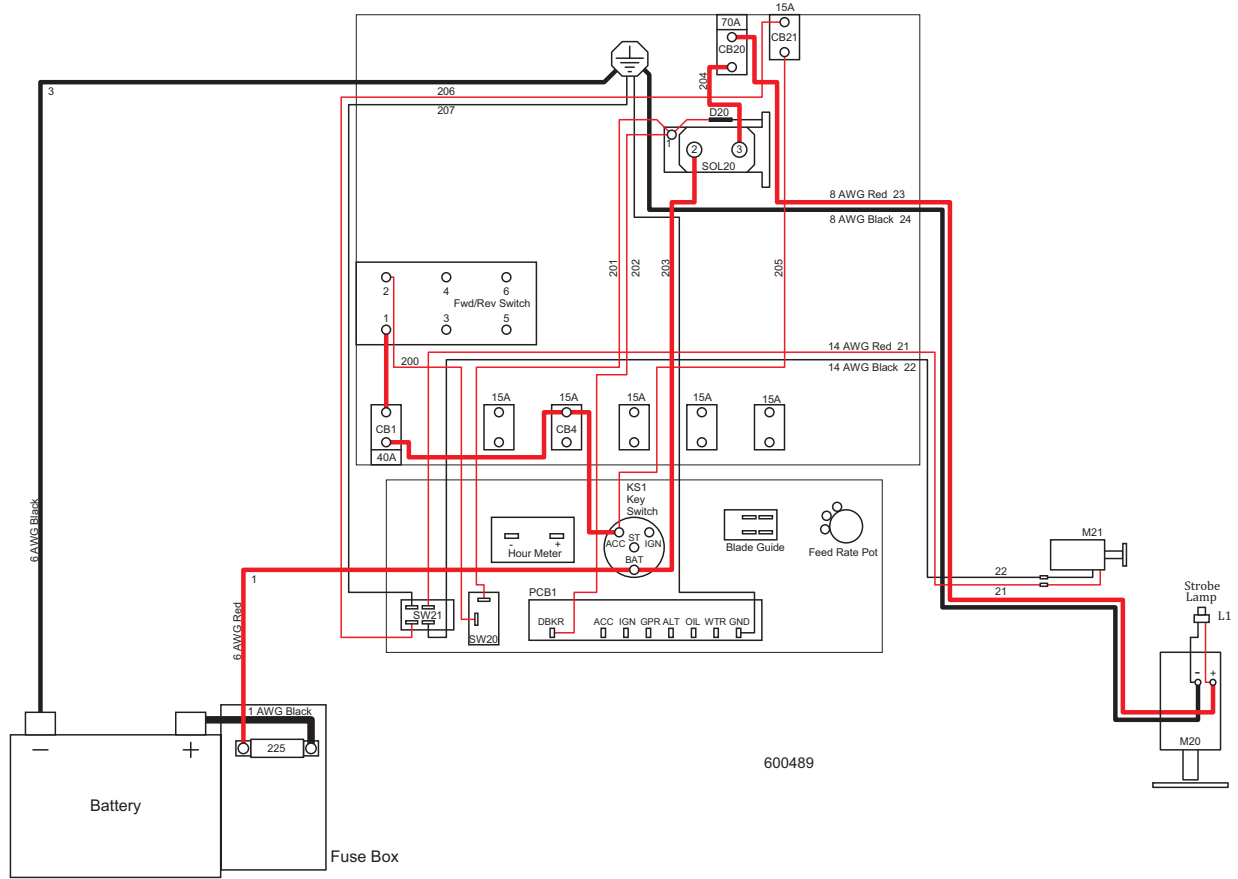
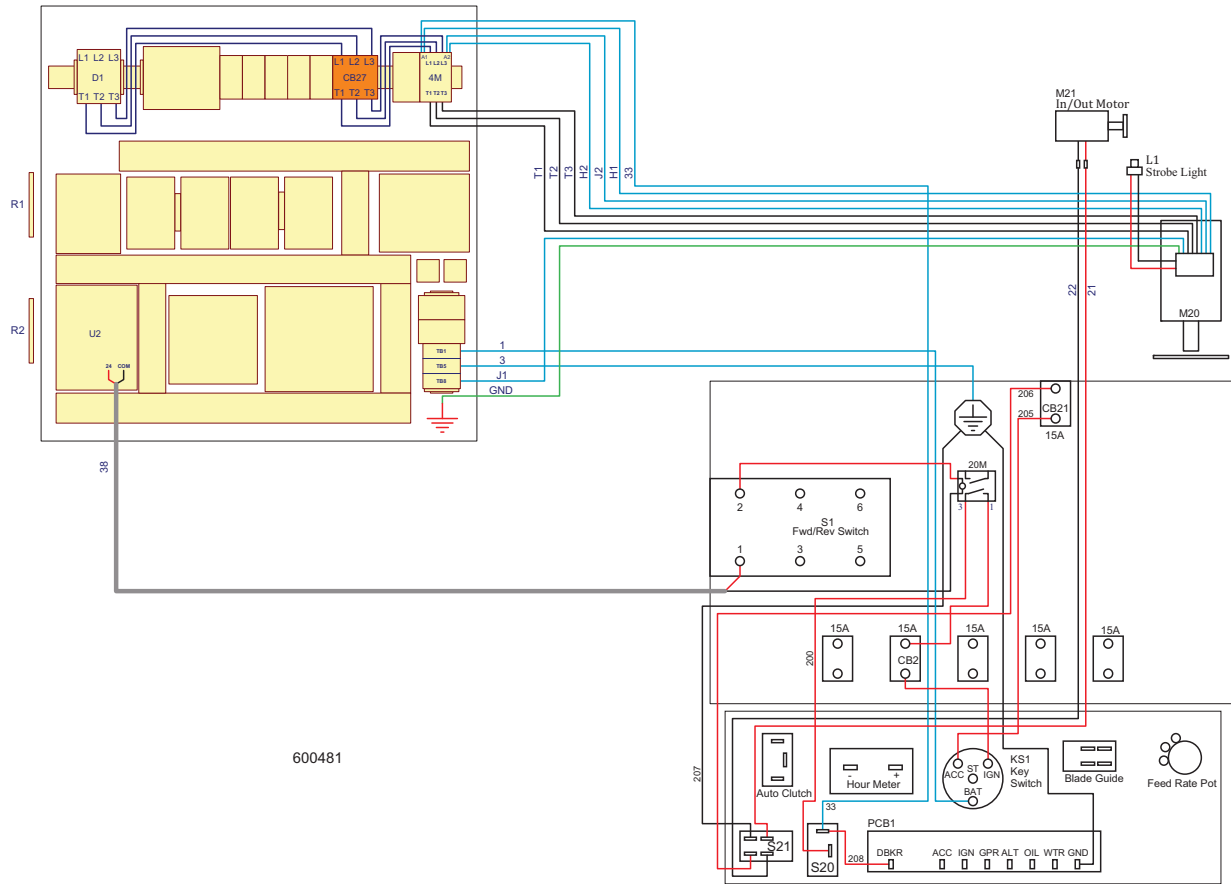

FIG. 5-7

Low/High Voltage



600481

FIG. 5-8

5.5 Debarker Electrical Wiring Diagram (Remote Sawmills)

Low/High Voltage

LT70HD RemoteRev. B6.07+

This diagram applies to Remote LT70HD model sawmills built after 1/09 with dual-axis Accuset 2 system.

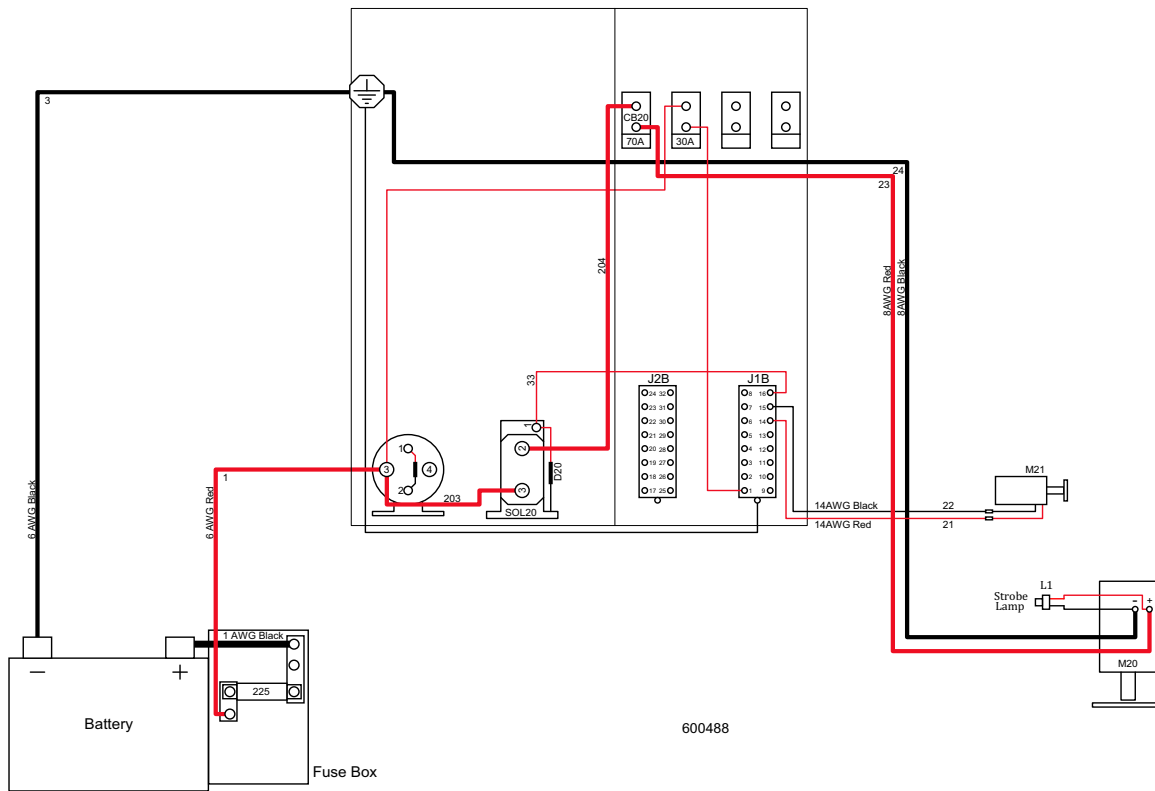

FIG. 5-9 (PAGE 1 OF 2)

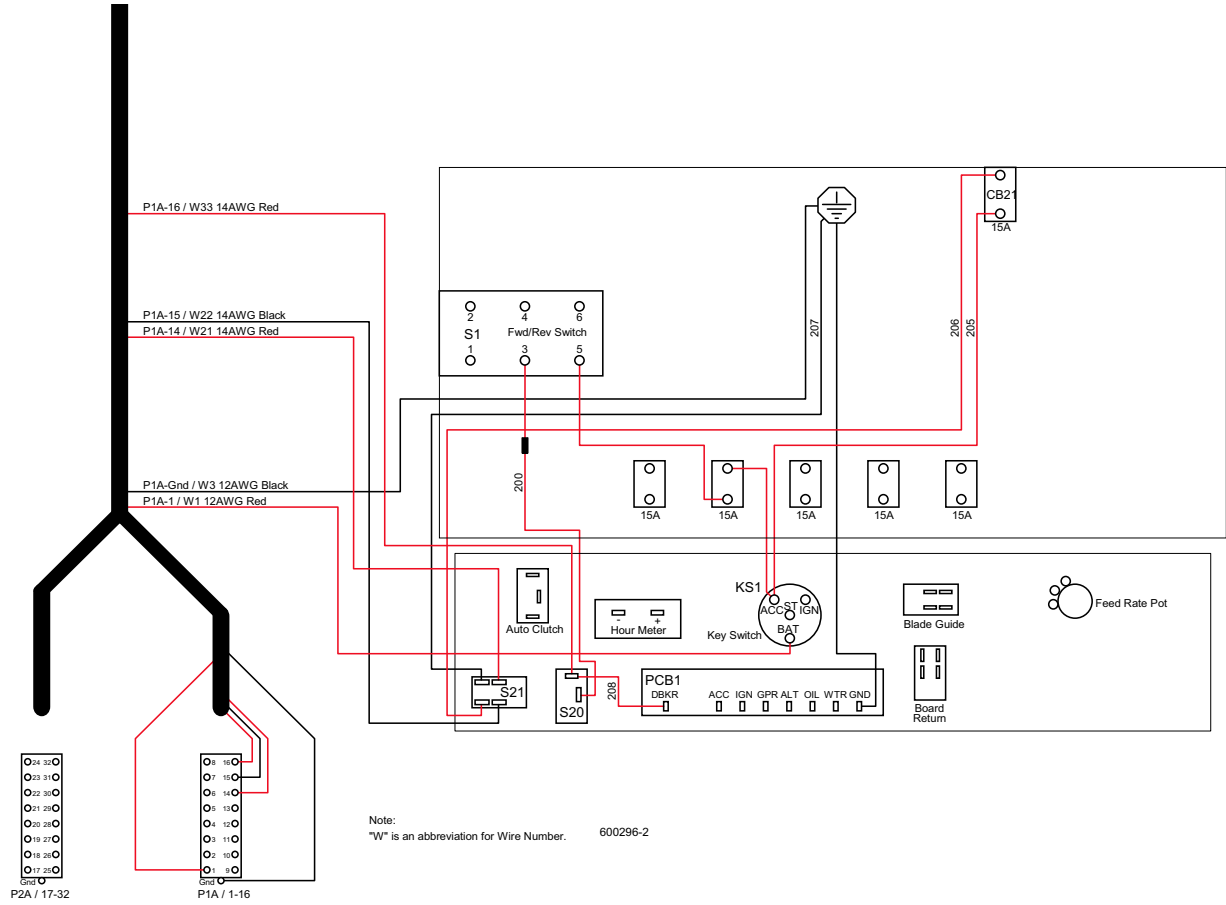

FIG. 5-10 (PAGE 2 OF 2)

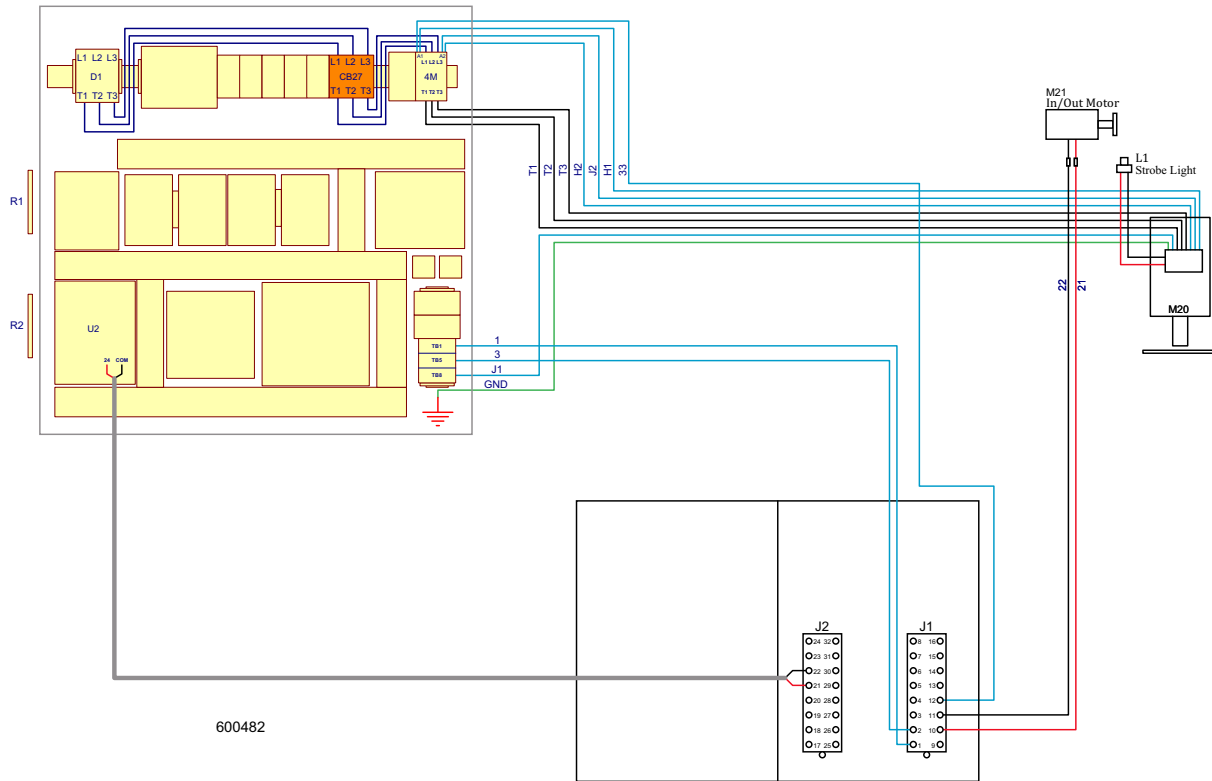

FIG. 5-11 (PAGE 1 OF 2)

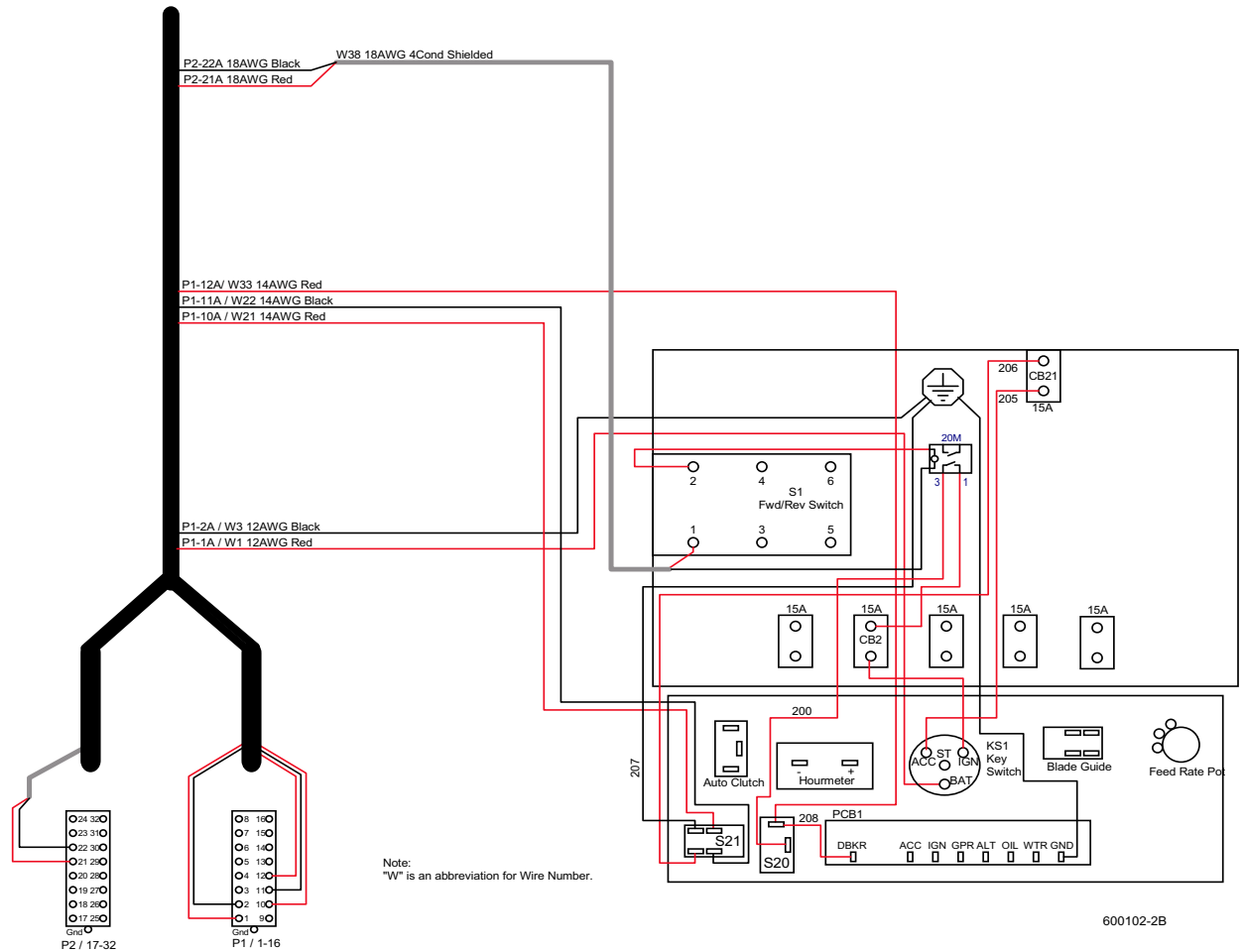

FIG. 5-12 (PAGE 2 OF 2)

5.6 Debarker Electrical Wiring Diagram (ACDC Wireless Sawmills)

LT70HD DC Wireless Rev. B6.07+

Low/High Voltage

This diagram applies to Wireless LT70HD DC model sawmills.

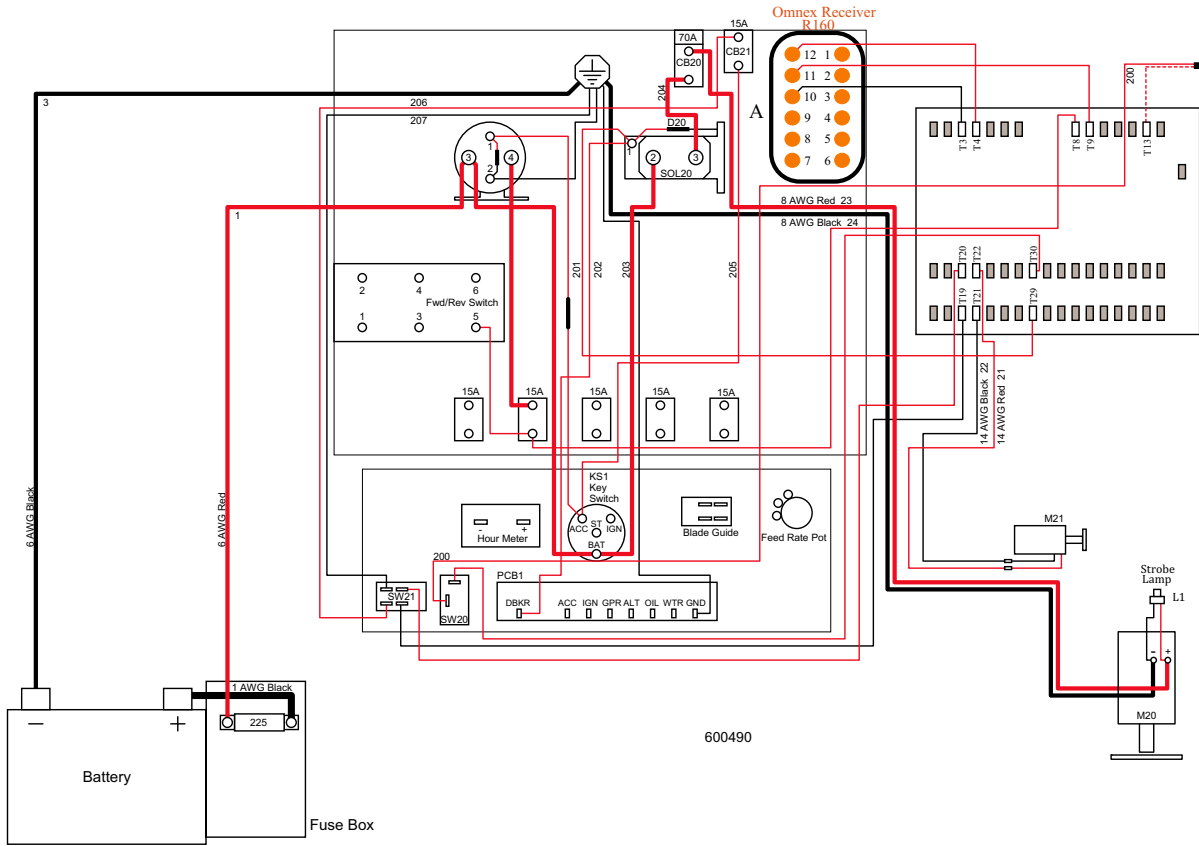

FIG. 5-13

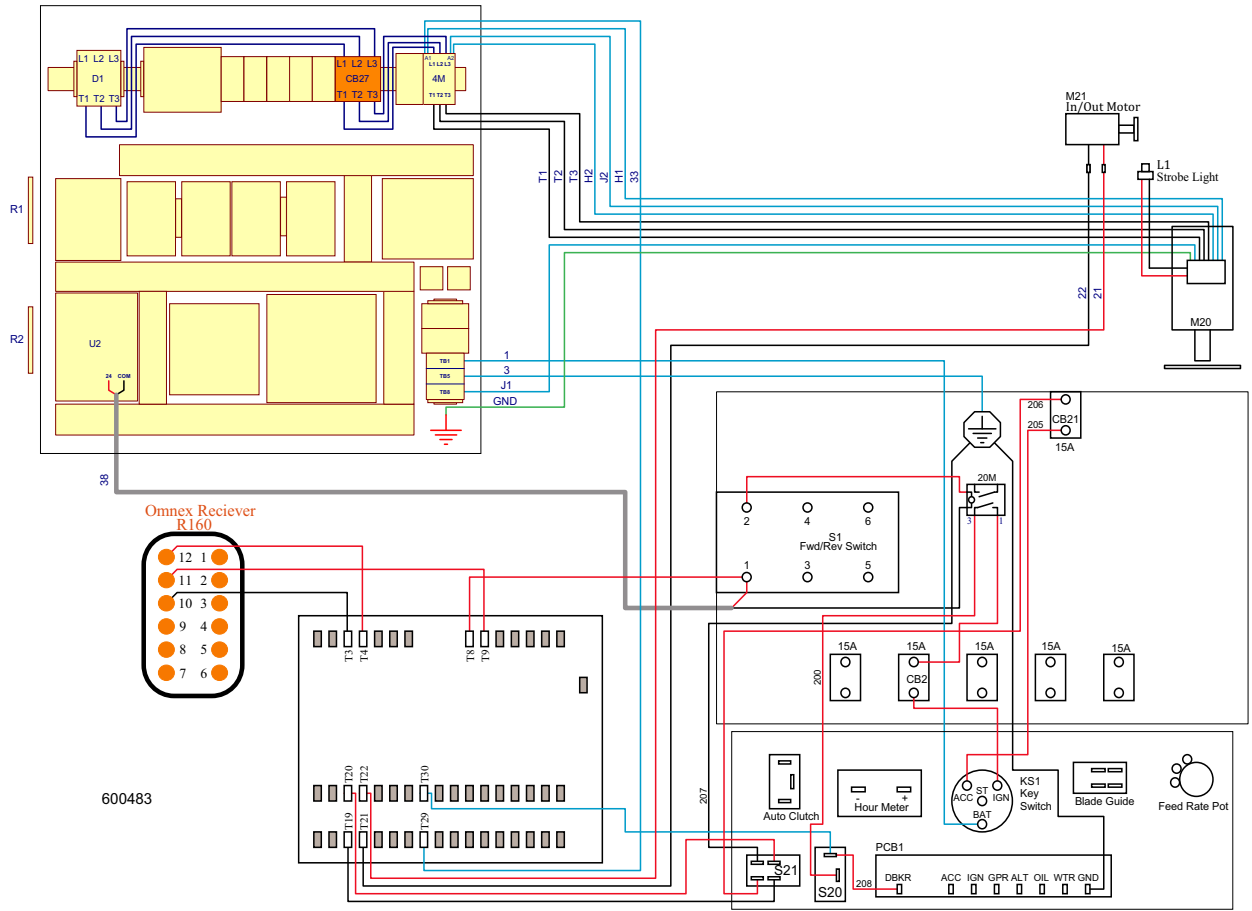
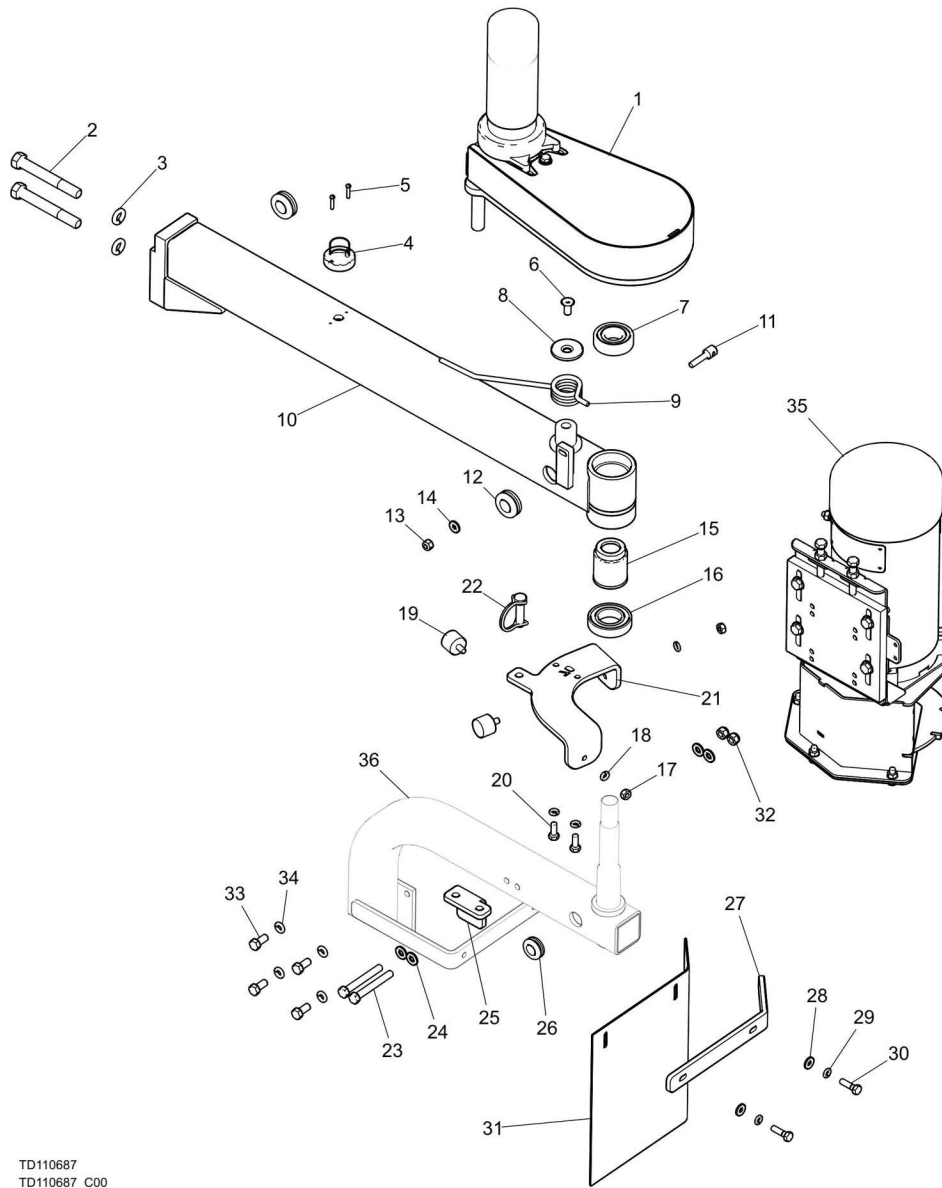

FIG. 5-14

SECTION 6 REPLACEMENT PARTS

6.1 LT70 DC Mechanical Debarker



TD110687
TD110687_C00

REF	PART #	DESCRIPTION	COMMENTS	QTY.
	110687	Assy, LT70 Mechanical Debarker		1
	110687W	Assy, LT70 Wide Mechanical Debarker		1
1		LT70 upper Pivot With Lock	(See Section 6.2)	1
	110684	Assy, LT70 Debarker Mnt Arm		1
2	F05008-78	1/2-13 x 4 HHB GR5 ZINC		2
3	F05011-9	Washer, 1/2 Split Lock		2
	073555	Lamp Assy, 180 Degree Amber Strobe		1
4	073554	Lamp, 180 Degree Amber Strobe		1
5	F05004-13	Bolt, #4-40x3/4 SI		2

REF	PART #	DESCRIPTION	COMMENTS	QTY.
6	F05006-95	Bolt, 5/16-18x3/4 FHS Zinc		1
7	087353	Bearing, 6205 2RS Ball		1
8	076039	Washer, LT35 Torsion Spring		1
9	098605	Spring, Debarker Torsion		1
10	110613	Wldmt, LT70 Debarker Mount Arm		1
11	076139	Bushing, Debarker Spring Retaining		1
12	025247	Grommet, Rubber 3/4 ID		2
13	F05010-69	Nut, 1/4-20 Nylock		1
14	F05011-11	Washer, 1/4 SAE Flat		1
15	110588	Tube, Long Bearing Spacer		1
16	036007	Bearing, R20-2RS		1
	074878	Assy, LT70 Debarker Pivot Stop		1
	074879	Assy, LT70 Wide Debarker Pivot Stop		1
17	F05010-63	Nut, 1/4-20 Free Hex		2
18	F05011-14	Washer, 1/4 Split Lock		4
19	065717	Bumper, 1x3/4 Hard Silicone Rubber		2
20	F05005-123	Bolt, 1/4-20x3/4 HH Gr5		2
21	076682	Plate, LT70 Debarker Pivot Stop		1
	076683	Plate, LT70 Wide Debarker Pivot Stop		1
22	046412	Pin, 3/8x1 3/8 Rnd Wire Lock		1
	110686	Assy, LT70 Debarker Pivot Arm		1
23	F05006-136	Bolt, 5/16-18x2 3/4 FT HH Gr5 Zinc		2
24	F05011-17	Washer, 5/16 SAE Flat		4
25	110616	Lock Brkt, Debarker Travel		1
26	033475	Grommet, 5/8 ID 3/16 GW Rubber		1
27	076749	Plate, Debarker Flex Guard Retaining		1
28	F05011-11	Washer, 1/4 SAE Flat		2
29	F05011-14	Washer, 1/4 Split Lock		2
30	F05005-38	Screw, 1/4-20x1 HHC		2
31	021232	Guard, Debarker Flex		1
32	F05010-58	Nut, 5/16-18 Nyl Lock		2
33	F05011-13	Washer, 5/16 Split Lock		4
34	F05006-5	Bolt, 5/16-18x3/4 HH Gr2		4
35	076677	Assy, LT70 Debarker Cutter Head	(See Section 6.3)	1
36	110685	Wldmnt, LT70 Debarker Pivot Arm		1

6.2 Upper Pivot With Lock

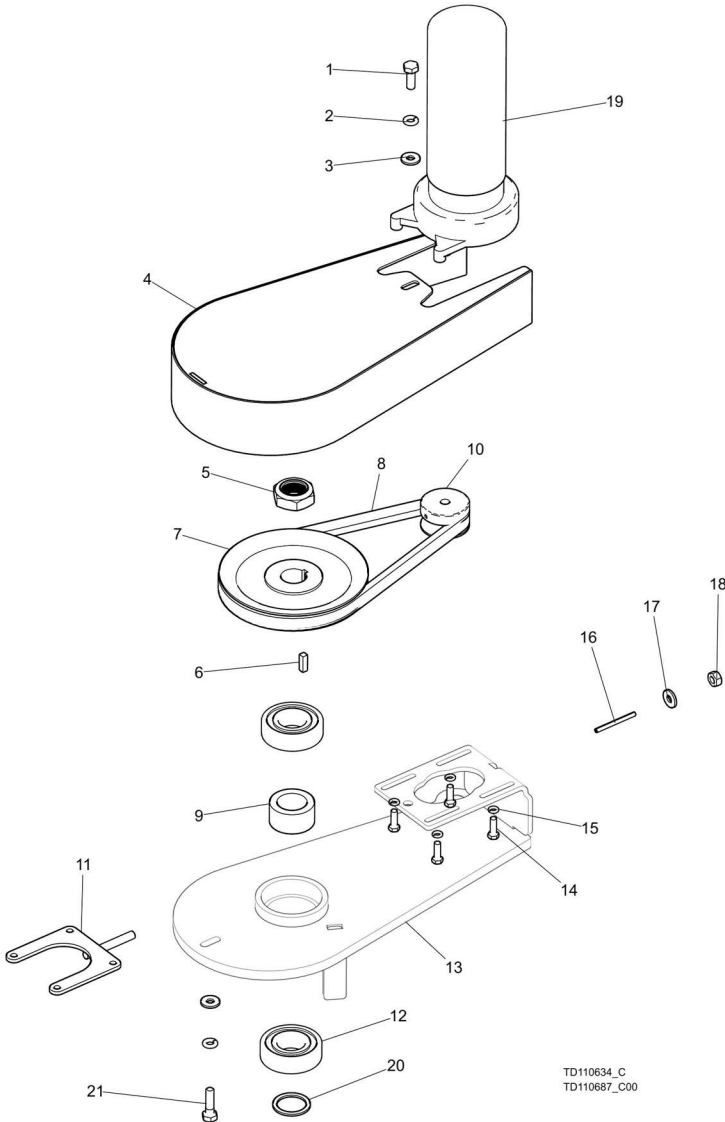

TD110634_C
TD110687_C00

REF	PART #	DESCRIPTION	COMMENTS	QTY.
		LT70 UPPER PIVOT WITH LOCK		1
1	F05005-1	Bolt, 1/4-20x3/4 FT HHC		1
2	F05011-14	Washer, 1/4 Split Lock		2
3	F05011-11	Washer, 1/4 SAE Flat		2
4	076713	Wldmnt, LT70 Debarker Belt Guard		1
5	F05010-238	Nut, 7/8-14 Half Nylock		1
6	065214	Key, 3/16 Sq x 5/8		1
7	076798	Pulley, 5x7/8 A Groove		1
8	076689	Belt, AX22		1
	110634	Assy, LT70 Deb. Upper Pivot W/O Lock		1
9	076741	Tube, Short Bearing Spacer		1
10	076666	Sheave, LT70 Debarker Gearmotor		1
11	023637	Tensioner Wldmt, Gearmotor		1
12	087353	Bearing, 6205 2RS Ball		2

6 Replacement Parts
Upper Pivot With Lock

REF	PART #	DESCRIPTION	COMMENTS	QTY.
13	110635	Wldmnt, LT70 Deb. Upper Pivot W/O Lock		1
14	F05004-152	Bolt, #10-32x5/8 HH		4
15	F05011-20	Washer, #10 Split Lock		4
16	F05012-102	Pin, 1/8x1 5/8 Roll Zinc		1
17	F05011-11	Washer, 1/4 SAE Flat		1
18	F05010-21	Nut, 1/4-20 Swaged		1
	114024	Motor Assy, Debarker In/Out w/Brake w/Di		1
19	110952	Motor, 1/15HP 34RPM 12VDC 98:1 W/Brake		1
	133750	Brake Kit, Gear Motor K01134-APAH		1
	133751	Gear Kit, Gear Motor K01134-APAG		1
20	076037	Shim, 1 ID 1-1/4 OD		1
21	F05005-101	BOLT, 1/4-20 X 1 HEX HEAD GR5		1

6.3 LT70 Debarker Cutter Head

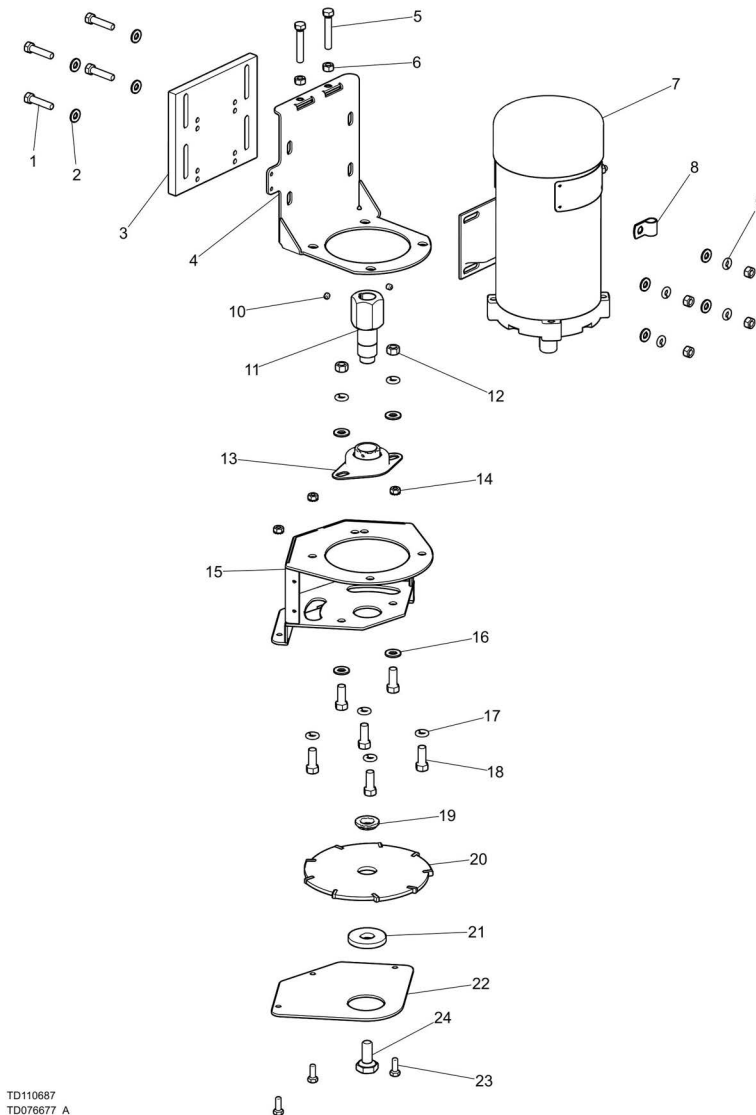

REF	PART #	DESCRIPTION	COMMENTS	QTY.
	076677	Assy, LT70 Debarker Cutter Head		1
1	F05006-2	Bolt, 5/16-18x1 1/2 HH FT		4
2	F05011-17	Washer, 5/16 SAE Flat		8
3	023620	Aluminum Plate, Motor Mnt		1
4	023622	Tensioner Weldment		1
5	F05006-13	Bolt, 5/16-18x2 HH FT		2
6	F05010-17	Nut, 5/16-18 Hex		6
7	023688	3/4 HP 12UDC TEFC Leeson, MKII		1
8	P07584	Clamp, 1/2EMT Coated		1
9	F05011-13	Washer, 5/16 Split Lock		4
10	F05005-105	1/4-28X1/4 Cup Point Set, B/O		2
11	074832	Mandrel, Debarker Blade		1
12	F05010-1	Nut, 3/8-16 Hex		2
13	023541	Bearing, 1 Flanged Mount		1

6 Replacement Parts
LT70 Debarker Cutter Head

REF	PART #	DESCRIPTION	COMMENTS	QTY.
14	F05010-9	Nut, 1/4-20 Keps		3
15	076686	Wldmnt, LT70 Debarker Cutter Head		1
16	F05005-1	Bolt, 1/4-20x3/4 FT HHC		3
17	F05011-3	Washer, 3/8 Flat SAE		4
18	F05011-4	Washer, 3/8 Split Lock		6
19	F05007-7	Bolt, 3/8-16x1 HH		6
20	023632	Bushing, Blade Spacer		1
21	021236	Blade, 7in Dia (Debarker)		1
22	023737	Washer, Blade Bolt Lock		1
23	074833	Bolt, 1/2-20x1 1/4 HH Special		1
24	023629	Guard, Cutter Head Bottom		1
	024431	Decal, Disconnect Motor Leads Warning		1

6.4 Mechanical Assembly (DC)

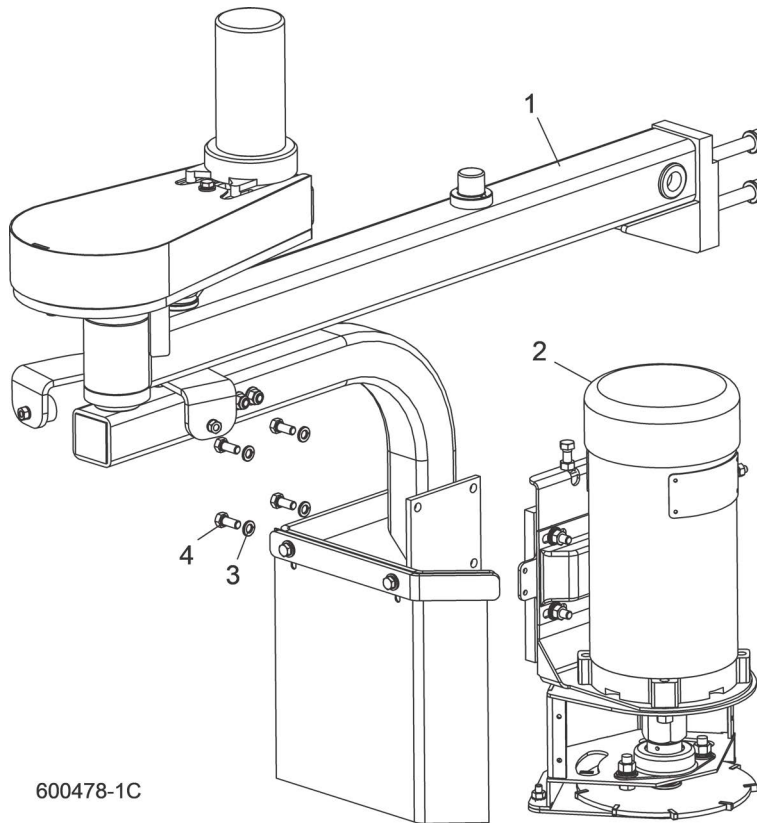

REF	PART #	DESCRIPTION	COMMENTS	QTY.
		NOTE: For field installation of existing sawmills, order the mechanical assembly below plus the appropriate control kit (See Section 6.10):		
	074882	MECHANICAL ASSEMBLY, LT70HD DC DEBARKER (BOXED)		1
	110687	Debarker Assembly, LT70 Mechanical		1
	076678	Debarker Assembly, LT70 Mechanical		1
	110687W	Assy, LT70 Wide Mechanical Debarker		1
	076678W	Debarker Assembly, LT70 Wide Mechanical (Wide Head Only)		1
1		Frame Parts (See Section 6.5)		
2		Cutter Head Parts (See Section 6.7)		
3	F05011-13	Washer, 5/16" Split Lock		4
4	F05006-5	Bolt, 5/16-18 x 3/4" Hex Head		4
	076683	Plate, LT70 Wide Debarker Pivot Stop		1
	015761	Cover, 3/4HP Leeson Motor		1

6.5 Frame Assembly (DC)

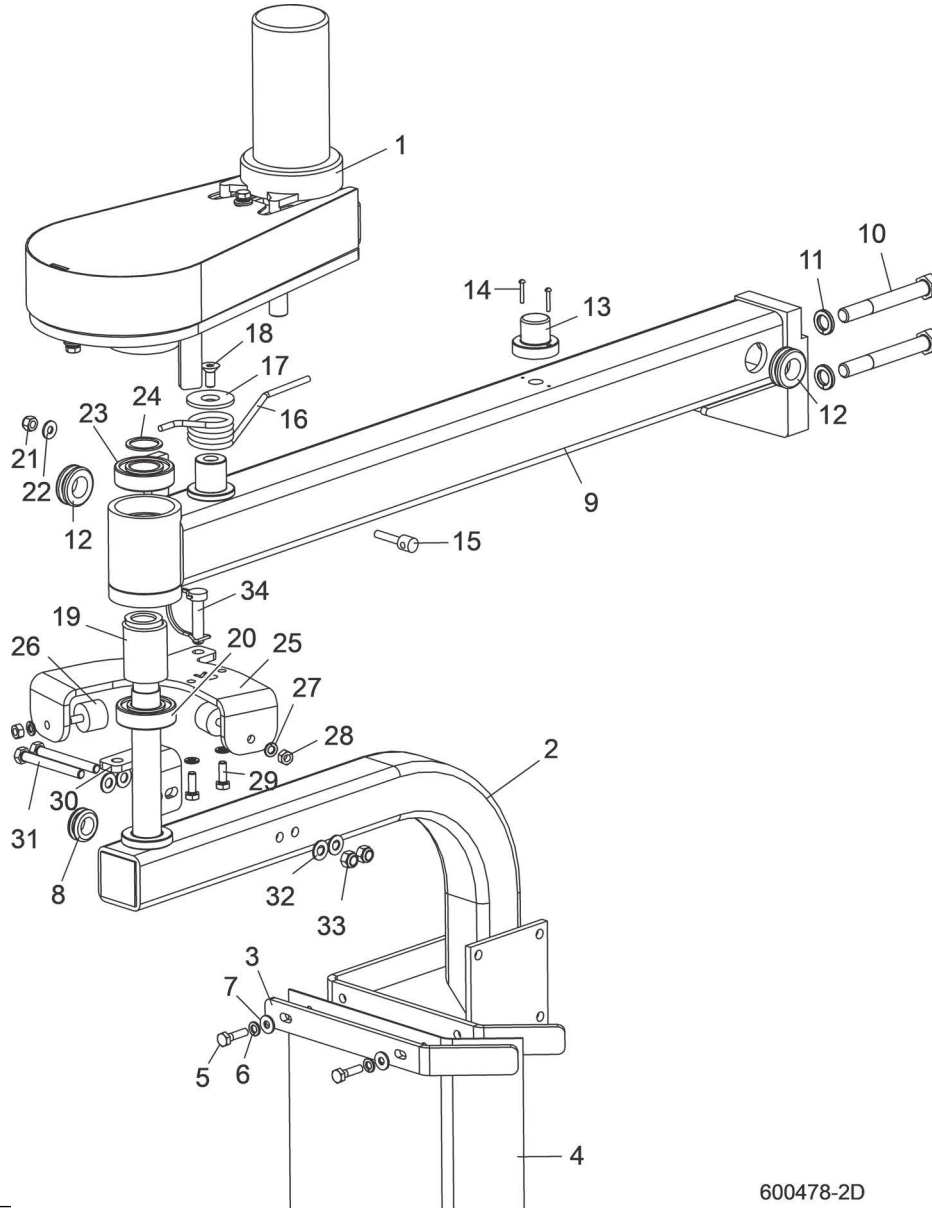

600478-2D

REF	PART #	DESCRIPTION	COMMENTS	QTY.
1		DEBARKER IN/OUT MOTOR PARTS (<i>(See Section 6.6)</i>)		
	110686	PIVOT ARM ASSEMBLY, LT70 DC DEBARKER		1
	110639	PIVOT ARM ASSEMBLY, LT70 DC DEBARKER		1
2	110685	Arm Weldment, LT70 Debarker Pivot		
	110638	Arm Weldment, LT70 Debarker Pivot		1
3	076749	Plate, Debarker Flex Guard Retaining		1
4	021232	Guard, Debarker Flex		1
5	F05005-38	Bolt, 1/4-20 x 1" Hex Head		2
6	F05011-14	Washer, 1/4" Split Lock		2
7	F05011-11	Washer, 1/4" SAE Flat		2
8	033475	Grommet, 5/8" ID 3/16" GW Rubber		1
		DC Cutter Head Parts (<i>(See Section 6.7)</i>)		
	110684	MOUNT ARM ASSEMBLY, LT70 DEBARKE		1
	110648	MOUNT ARM ASSEMBLY, LT70 DEBARKER		1
9	110613	Mount Arm Weldment, LT70 Debarker		

REF	PART #	DESCRIPTION	COMMENTS	QTY.
	110647	Mount Arm Weldment, LT70 Debarker		1
10	F05008-78	Bolt, 1/2-13 x 4" Hex Head Grade 5		2
11	F05011-9	Washer, 1/2" Split Lock		2
12	025247	Grommet, Rubber 3/4 ID		2
13	073555	Lamp Assembly, 180 Degree Amber Strobe		1
14	F05004-13	Bolt, 4-40 x 3/4 SI		2
15	076139	Bushing, Debarker Spring Retaining		1
16	098605	Spring, Debarker Tension		1
17	076039	Washer, LT35 Torsion Spring		1
18	F05006-95	Bolt, 5/16-18 x 3/4" FHS		1
19	110588	Tube, Long Bearing Spacer		1
	076739	Tube, Long Bearing Spacer		1
20	036007	Bearing, R20-2RS		1
21	F05010-69	Nut, 1/4-20 Nylock		1
22	F05011-11	Washer, 1/4" SAE Flat		1
23	087353	Bearing, SKF 6205 2RS Roller		1
24	076037	SHIM, 1 ID 1-1/4" OD		1
	074878	STOP ASSEMBLY, LT70 DEBARKER PIVOT		1
	074879	STOP ASSEMBLY, LT70 WIDE DEBARKER PIVOT (WIDE HEAD ONLY)		1
25	076682	Plate, LT70 Debarker Pivot Stop		1
	076683	Plate, LT70 Wide Debarker Pivot Stop (Wide Head Only)		1
26	065717	Bumper, 1 x 3/4" Hard Silicone Rubber		2
27	F05011-14	Washer, 1/4" Split Lock		2
28	F05010-63	Nut, 1/4-20 Free		2
29	F05005-123	Bolt, 1/4-20 x 3/4" Hex Head Grade 5		2
30	110616	LOCK BRACKET, DEBARKER TRAVEL		1
31	F05006-136	BOLT, 5/16-18X2 3/4 FT HH GR5		2
32	F05011-17	WASHER, 5/16 SAE FLAT		4
33	F05010-58	NUT, 5/16-18 NYLOK HEX		2
34	046412	PIN, 3/8X1 3/8 ROUND WIRE LOCK		1

Frame Assembly (AC)

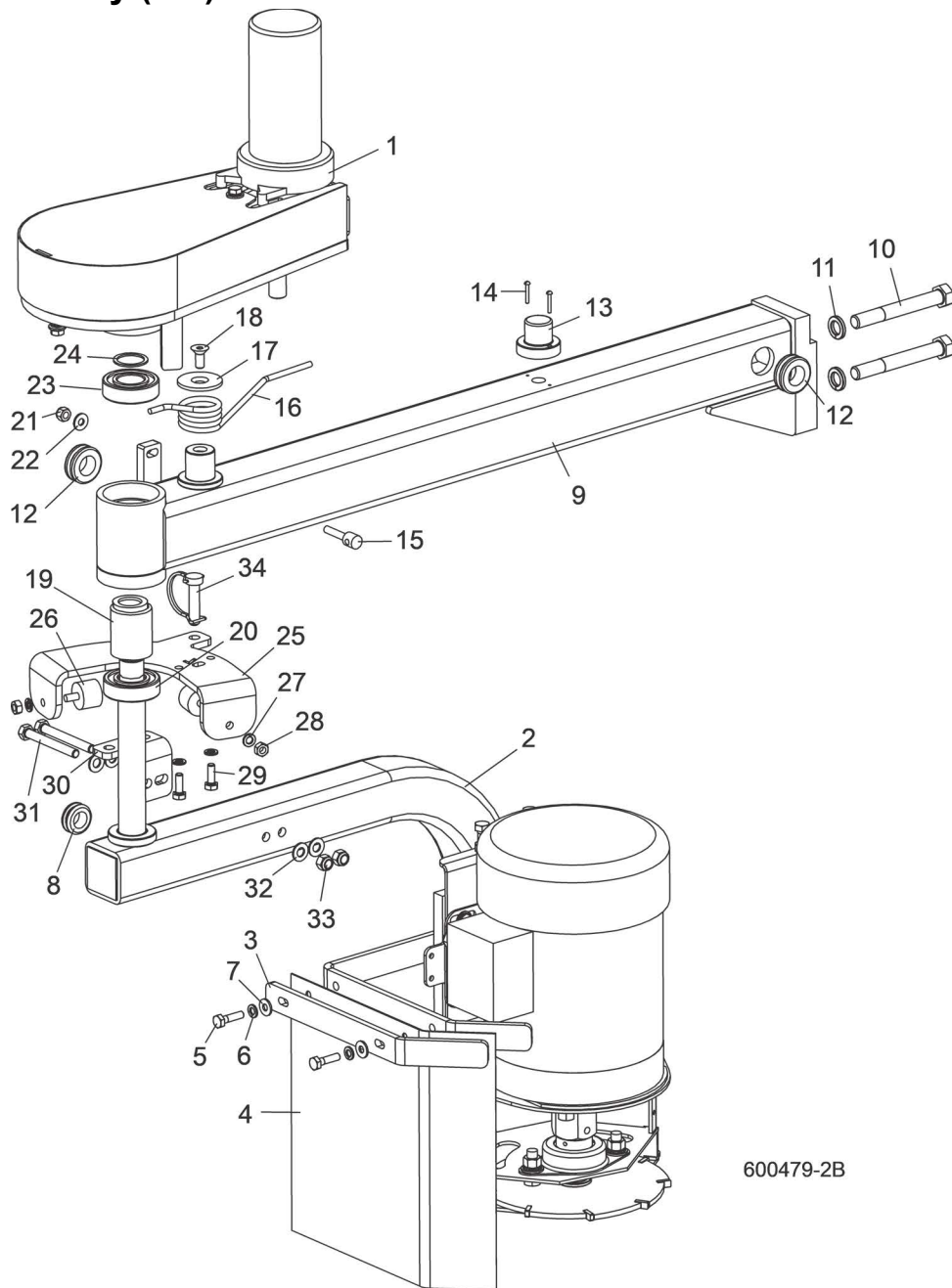

600479-2B

REF	PART #	DESCRIPTION	COMMENTS	QTY.
1		DEBARKER IN/OUT MOTOR PARTS (See Section 6.6)		
	110689	PIVOT ARM ASSEMBLY, LT70 AC DEBARKER	110689 replaced 110640 after 5/23/2019 per ECN 35897.	1
	110640	PIVOT ARM ASSEMBLY, LT70 AC DEBARKER		1
2	110685	Arm Weldment, LT70 Debarker Pivot	110685 replaced 110638 after 5/23/2019 per ECN 35897.	1
	110638	Arm Weldment, LT70 Debarker Pivot		1
3	076749	Plate, Debarker Flex Guard Retaining		1
4	021232	Guard, Debarker Flex		1
5	F05005-38	Bolt, 1/4-20 x 1" Hex Head		2
6	F05011-14	Washer, 1/4" Split Lock		2
7	F05011-11	Washer, 1/4" SAE Flat		2

REF	PART #	DESCRIPTION	COMMENTS	QTY.
8	033475	Grommet, 5/8" ID 3/16" GW Rubber		1
		AC Cutter Head Parts (<i>(See Section 6.8)</i>)		
	110684	MOUNT ARM ASSEMBLY, LT70 DEBARKER	110684 replaced 110648 after 5/23/2019 per ECN 35897.	1
	110648	MOUNT ARM ASSEMBLY, LT70 DEBARKER		1
9	110613	Mount Arm Weldment, LT70 Debarker	110613 replaced 110647 after 5/23/2019 per ECN 35897.	1
	110647	Mount Arm Weldment, LT70 Debarker		1
10	F05008-78	Bolt, 1/2-13 x 4" Hex Head Grade 5		2
11	F05011-9	Washer, 1/2" Split Lock		2
12	025247	Grommet, Rubber 3/4 ID		2
13	073555	Lamp Assembly, 180 Degree Amber Strobe		1
14	F05004-13	Bolt, 4-40 x 3/4 SI		2
15	076139	Bushing, Debarker Spring Retaining		1
16	098605	Spring, Debarker Tension		1
17	076039	Washer, LT35 Torsion Spring		1
18	F05006-95	Bolt, 5/16-18 x 3/4" FHS		1
19	110588	Tube, Long Bearing Spacer	110588 replaced 076739 after 5/23/2019 per ECN 35897.	1
	076739	Tube, Long Bearing Spacer		1
20	036007	Bearing, R20-2RS	036007 replaced (1) 087353 after 5/23/2019 per ECN 35897.	1
	087353	Bearing, SKF 6205 2RS Roller		1
21	F05010-69	Nut, 1/4-20 Nylock		1
22	F05011-11	Washer, 1/4" SAE Flat		1
23	087353	Bearing, SKF 6205 2RS Roller		1
24	076037	SHIM, 1 ID 1-1/4" OD		1
	074878	STOP ASSEMBLY, LT70 DEBARKER PIVOT		1
	074879	STOP ASSEMBLY, LT70 WIDE DEBARKER PIVOT (WIDE HEAD ONLY)		1
25	076682	Plate, LT70 Debarker Pivot Stop		1
	076683	Plate, LT70 Wide Debarker Pivot Stop (Wide Head Only)		1
26	065717	Bumper, 1 x 3/4" Hard Silicone Rubber		2
27	F05011-14	Washer, 1/4" Split Lock		2
28	F05010-63	Nut, 1/4-20 Free		2
29	F05005-123	Bolt, 1/4-20 x 3/4" Hex Head Grade 5		2
30	110616	LOCK BRACKET, DEBARKER TRAVEL		1
31	F05006-136	BOLT, 5/16-18X2 3/4 FT HH GR5		2
32	F05011-17	WASHER, 5/16 SAE FLAT		4
33	F05010-58	NUT, 5/16-18 NYLOK HEX		2
34	046412	PIN, 3/8X1 3/8 ROUND WIRE LOCK		1

6.6 In/Out Motor Drive Assembly

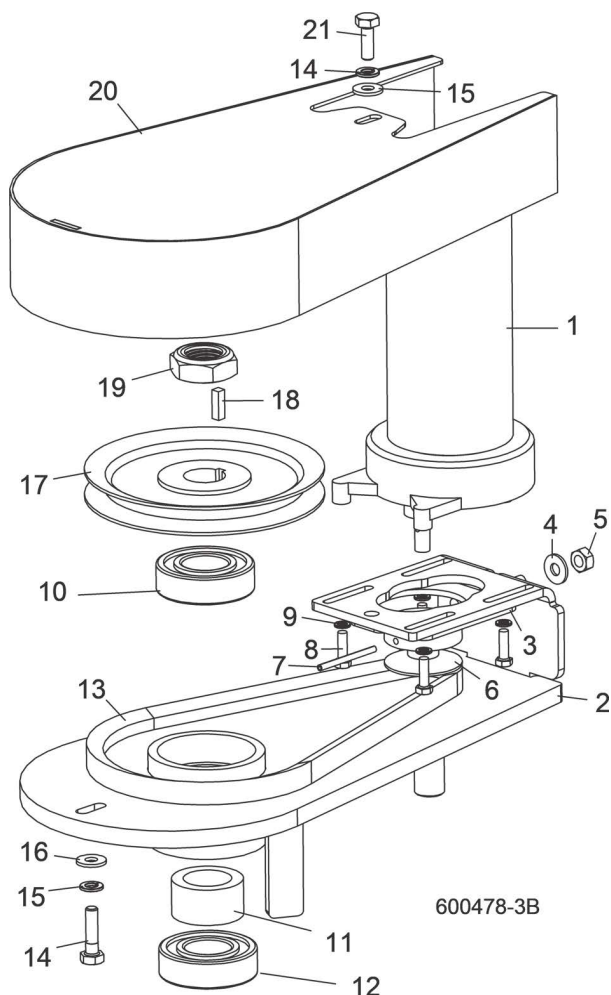

600478-3B

REF	PART #	DESCRIPTION	COMMENTS	QTY.
	110634	PIVOT ASSEMBLY, LT70 DEBARKER UPPER		1
1	128026	Motor Assy, Debarker In/Out w/Brake w/Di		1
	074826	Gearmotor Assembly, LT70 Debarker In/Out		1
	061228	Gear Kit, Motor		1
	061229	Shaft Kit, Motor		1
	061230	Brush Kit, Motor		1
2	110635	Pivot Weldment, LT70 Debarker Upper		1
3	023637	Tensioner Weldment, Gear Motor		1
4	F05011-11	Washer, 1/4" SAE Flat		1
5	F05010-21	Nut, 1/4-20 Swaged		1
6	076666	Sheave, LT70 Debarker Gearmotor		1
7	F05012-102	Pin, 1/8 x 1 5/8 Roll		1
8	F05004-152	Screw, 10-32 x 5/8 HH Machine		4
9	F05011-20	Washer, #10 Split Lock		4
10	087353	Bearing, SKF 6205 2RS Roller		1
11	076741	Tube, Short Bearing Spacer		1
12	036007	Bearing, R20-2RS	036007 replaced (1) 087353 after 5/23/2019 per ECN 35897.	1
13	076689	BELT, AX22		1

REF	PART #	DESCRIPTION	COMMENTS	QTY.
14	F05005-101	BOLT, 1/4-20 X 1" HEX HEAD GRADE 5		1
15	F05011-14	WASHER, 1/4" SPLIT LOCK		2
16	F05011-11	WASHER, 1/4" SAE FLAT		2
17	076798	PULLEY, 5X7/8 A GROOVE		1
18	065214	KEY, 3/16" SQ X 5/8"		1
19	F05010-238	NUT, 7/8-14 HALF NYLOCK		1
20	076713	GUARD WELDMENT, LT70 DEBARKER BELT		1
21	F05005-1	BOLT, 1/4-20 X 3/4" FULL THREAD HHC		1

6.7 Blade Motor Assembly (DC)

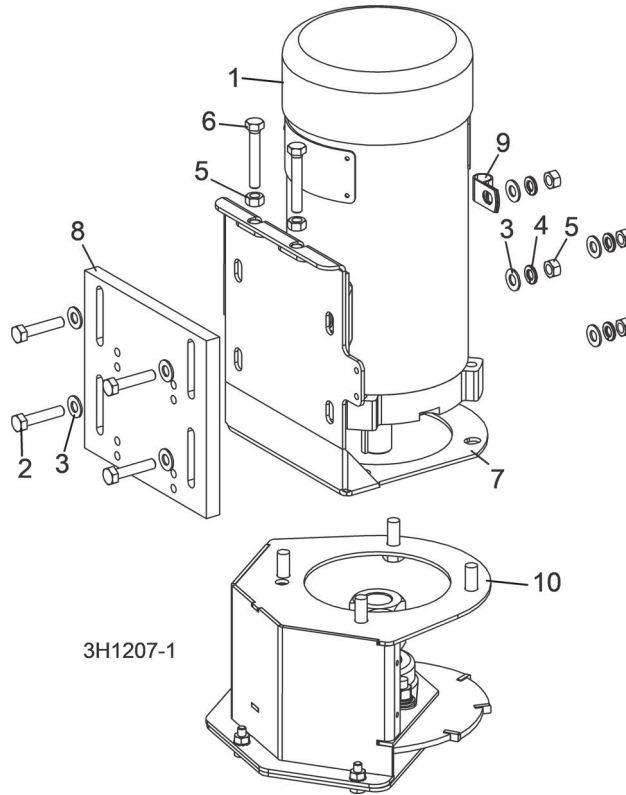

REF	PART #	DESCRIPTION	COMMENTS	QTY.
	076677	HEAD ASSEMBLY, LT70 DEBARKER CUTTING		1
1	023688	Motor, 3/4HP 12VDC TEFC Electric (7/8" Dia. Shaft)		1
	024167	Brush Kit, Leeson 3/4HP Motor (Includes 2 Brushes and 2 Springs)		1
	016087	Fan, 3/4 HP Leeson Motor Replacement		1
	047998	Guard, Motor Fan		1
	016108	Key, 3/16" Square x 1 3/8" Long		1
2	F05006-2	Bolt, 5/16-18 x 1 1/2" Hex Head Full Thread		4
3	F05011-17	Washer, 5/16" SAE Flat		8
4	F05011-13	Washer, 5/16" Split Lock		4
5	F05010-17	Nut, 5/16-18 Hex		6
6	F05006-13	Bolt, 5/16-18 x 2" Hex Head Full Thread		2
7	023622	Bracket Weldment, Debarker Blade Motor Adjustable		1
8	023620	Plate, Debarker Blade Motor Mount		1
9	P07584	Clamp, 1/2EMT Coated		1
	024431	Decal, Disconnect Motor Leads Warning		1
10		Blade/Mandrel Parts (<i>See Section 6.9</i>)		

6.8 Blade Motor Assembly (AC)

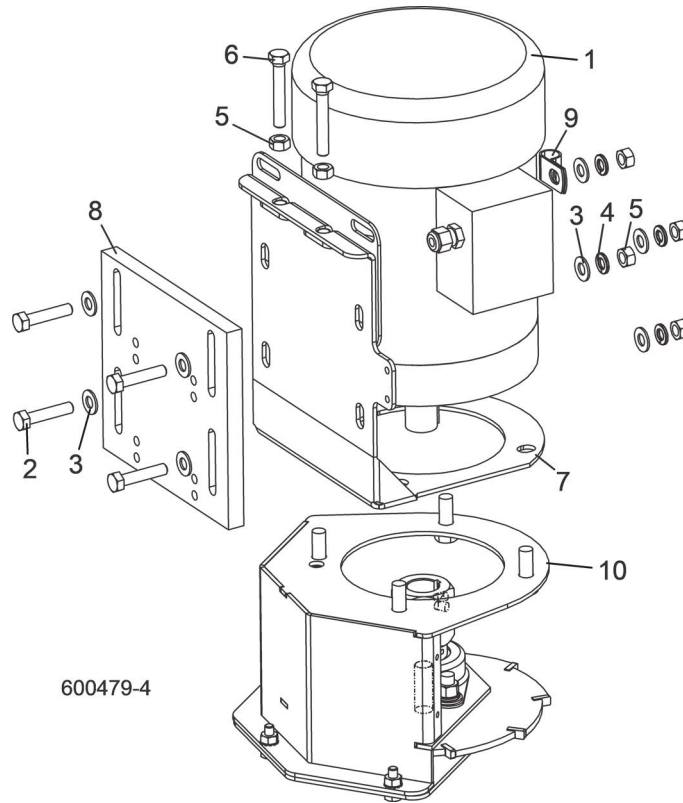

REF	PART #	DESCRIPTION	COMMENTS	QTY.
	074858	HEAD ASSEMBLY, LT70 AC DEBARKER CUTTING		1
1	050292	Motor, 3/4HP 230/460V 1725RPM Electric		1
	016108	Key, 3/16" Square x 1 3/8" Long		1
2	F05006-2	Bolt, 5/16-18 x 1 1/2" Hex Head Full Thread		4
3	F05011-17	Washer, 5/16" SAE Flat		8
4	F05011-13	Washer, 5/16" Split Lock		4
5	F05010-17	Nut, 5/16-18 Hex		6
6	F05006-13	Bolt, 5/16-18 x 2" Hex Head Full Thread		2
7	023622	Bracket Weldment, Debarker Blade Motor Adjustable		1
8	023620	Plate, Debarker Blade Motor Mount		1
9	P07584	Clamp, 1/2EMT Coated		1
	024431	Decal, Disconnect Motor Leads Warning		1
10		Blade/Mandrel Parts	<i>(See Section 6.9)</i>	

6.9 Blade Housing Assembly

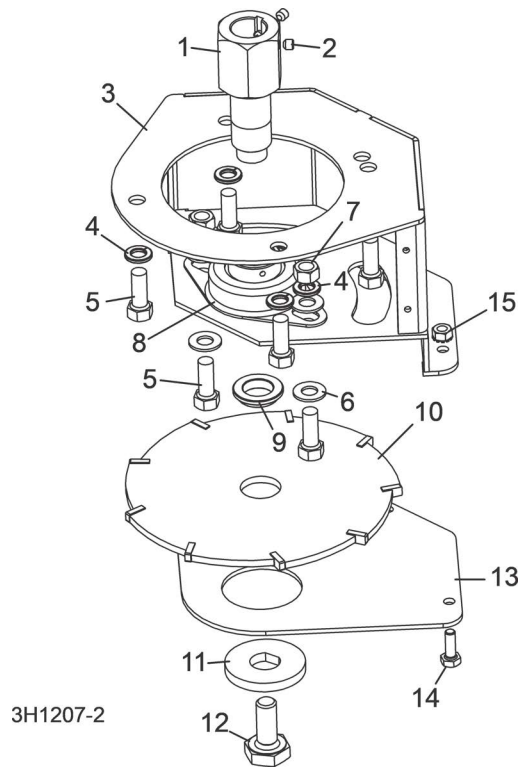

REF	PART #	DESCRIPTION	COMMENTS	QTY.
1	074832	MANDREL, DEBARKER BLADE		1
2	F05005-105	SCREW, 1/4-28 X 1/4" CUP POINT SOCKET SET		2
3	076686	HEAD WELDMENT, LT70 DEBARKER CUTTER		1
4	F05011-4	WASHER, 3/8" SPLIT LOCK		6
5	F05007-7	BOLT, 3/8-16 X 1" HEX HEAD		6
6	F05011-3	WASHER, 3/8" SAE FLAT		4
7	F05010-1	NUT, 3/8-16 HEX		2
8	023541	BEARING, 1" FLANGED MOUNT		1
9	023632	BUSHING, DEBARKER BLADE SPACER		1
10	021236	BLADE, DEBARKER 7" DIA.		1
	065852	BLADE, DEBARKER 7" DIA. W/1/2" INSERTS	OPTIONAL	1
11	023737	WASHER, DEBARKER BLADE LOCK		1
12	074833	BOLT, 1/2-20 X 1 1/4" HEX HEAD SPECIAL		1
13	023629	PLATE, DEBARKER BLADE HOUSING BOTTOM		1
14	F05005-1	BOLT, 1/4-20 X 3/4" HEX HEAD FULL THREAD		3
15	F05010-9	NUT, 1/4-20 SELF-LOCKING HEX		3
	076799	DECAL, DEBARKER LIGHT WARNING		1

6.10 Debarker Control Assembly

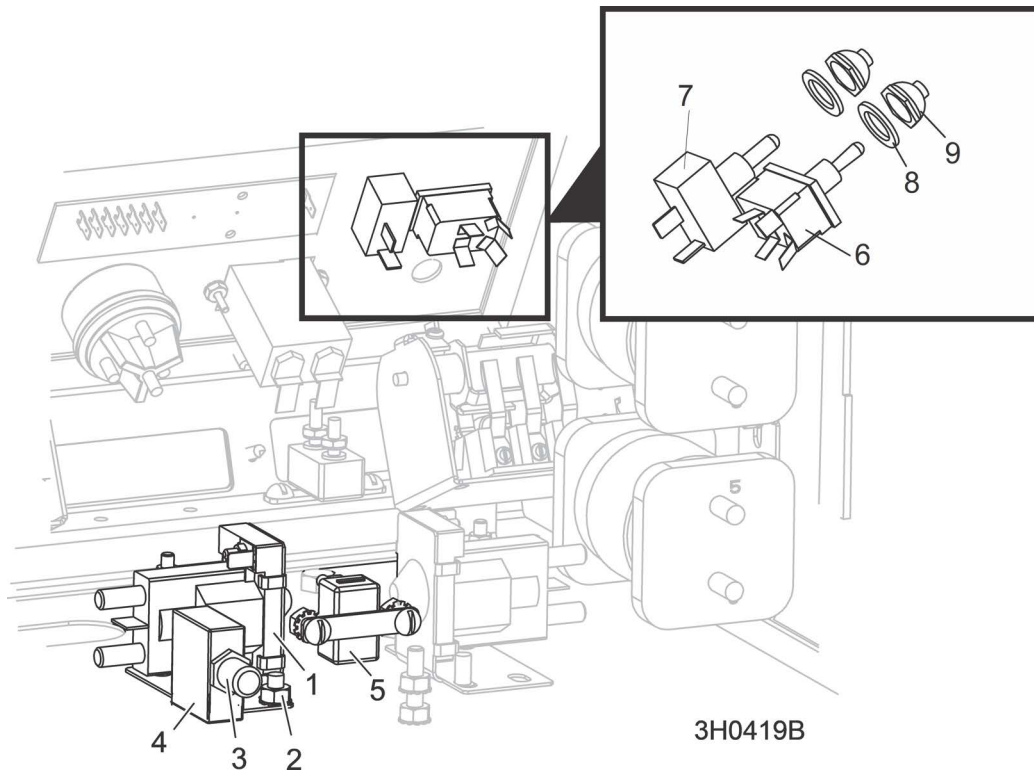

REF	PART #	DESCRIPTION	COMMENTS	QTY.
	023676	CONTROL ASSEMBLY, DEBARKER (NON-REMOTE)		1
	023677	CONTROL ASSEMBLY, DEBARKER (REMOTE)		1
1	016372	Solenoid Kit, Accessory		1
	P10449	Solenoid, 100A 12V Cont. Duty GND	Available in assemblies only.	1
	015426	Diode Assembly, Solenoid Coil Chassis GND		1
2	F05010-9	Nut, 1/4-20 Self Locking		2
3	021253	Boot, Circuit Breaker		1
4	015527	Breaker, 70 Amp Manual Reset Panel Mount		1
5	E20430	Breaker, 15 Amp Manual Reset		1
6	024200	Switch, DPDT Toggle Return Center Screw Terminal		1
7	P03027	Switch, SPST Toggle Quick Connect		1
8	P05251-1	Washer, 1/2 x 3/4 x 1/16" Nylon		2
9	P02575	Boot, Toggle Switch		2

6 Replacement Parts
Debarker Control Assembly

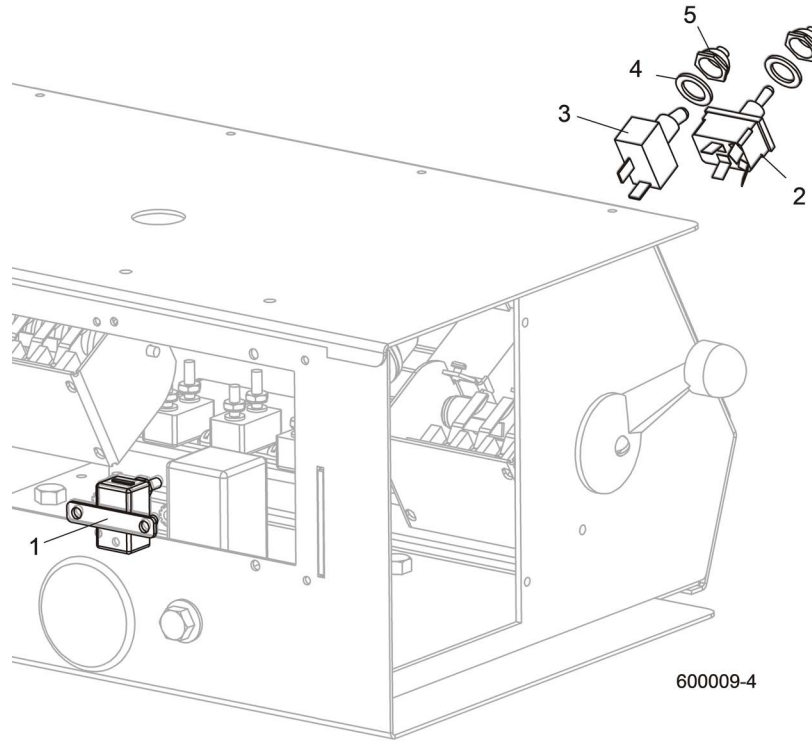

REF	PART #	DESCRIPTION	COMMENTS	QTY.
	050912	CONTROL ASSEMBLY, DEBARKER AC LT70		1
	050428	Harness Assembly, Debarker AC LT70 E25/E30		1
1	E20430	Breaker, 15 Amp Manual Reset		1
2	024200	Switch, DPDT Toggle Return Center Screw Terminal		1
3	P03027	Switch, SPST Toggle Quick Connect		1
4	P05251-1	Washer, 1/2 x 3/4 x 1/16" Nylon		2
5	P02575	Boot, Toggle Switch		2