

Wood-Mizer[®] Sawmill

Safety, Setup, Operation & Maintenance Manual

1992 LT30HD
1992 LT40HD

rev. C7 - F7
rev. C7 - F7



Safety is our #1 concern! Read and understand all safety information and instructions before operating, setting up or maintaining this machine.

October 2004

Form #625

This manual is to replace or to be used with all previous information received on the Wood-Mizer®* sawmill. All future mailings will be an addition to or a revision of individual sections of this manual as we obtain new information.

The information and instructions given in this manual do not amend or extend the limited warranties for the equipment given at the time of purchase.

If You Need To Order Parts...

From the continental U.S., call our toll-free Parts hotline at **1-800-525-8100**. Please have the vehicle identification number and your customer number ready when you call. Wood-Mizer will accept these methods of payment:

- Visa, Mastercard, or Select Purchase
- COD
- Prepayment
- Net 15 (with approved credit)

Be aware that shipping and handling charges may apply. Handling charges are based on size and quantity of order. In most cases, items will ship on the day they are ordered. Second Day and Next Day shipping are available at additional cost.

If your sawmill was purchased outside of the United States, contact your distributor for replacement parts.

If You Need Service...

From the continental U.S., call us toll-free at **1-800-525-8100**. Ask to speak with a Customer Service Representative. Please have your vehicle identification number and your customer number ready when you call. The Service Representative can help you with questions about alignment of your mill, blade sharpening, or cutting a particular species of wood. He also can schedule you for a service call.

Office Hours:

All times are Eastern Standard Time. Please remember that Indiana does not go on Daylight Savings Time in the summer.

Monday - Friday 8 a.m. to 5 p.m.

Saturday 8 a.m. to 12 p.m.

If your sawmill was purchased outside the United States, contact the distributor for service.



IMPORTANT! Read the entire Operator's Manual before operating the sawmill. Take notice of all safety warnings throughout this manual and those posted on the machine. Keep this manual with this machine at all times, regardless of ownership.

*Wood-Mizer® is a registered trademark of Wood-Mizer Products, Inc.

**Your Vehicle Identification Number And
Customer Number**

Each Wood-Mizer sawmill has a 17-digit Vehicle Identification Number (VIN). See the figure below for VIN locations. See the chart at the right for VIN description.

Each sawmill is also identified with a model number which includes the base model and the engine/motor configuration. An 's' after the model number indicates the model is approved for sale in countries that have adopted German "Gerprüfte Sicherheit: (G.S.)" safety standards. The model number is located on the middle blade housing cover. See the figure at the right for a description of the model number.

When you pick up your mill, you will receive a customer number. Both the VIN and your customer number expedite our service to you. Please write these numbers below so you have quick, easy access to them.

VIN: _____

Customer No: _____

Model No: _____

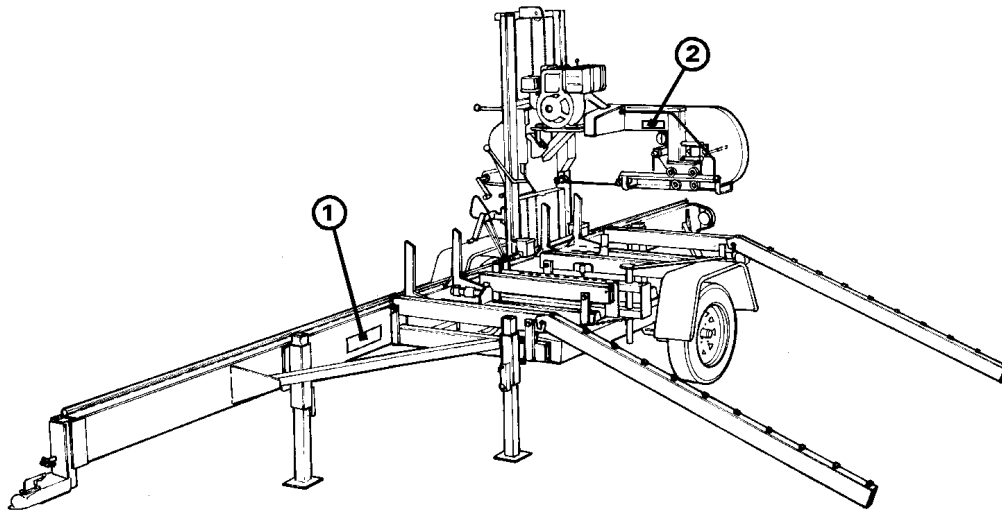

VEHICLE IDENTIFICATION NUMBER LOCATIONS.

456A5241XSNA B1017	COMPANY IDENTIFICATION NUMBER 456=WOOD-MIZER INDIANA
	WEIGHT CLASS; A=UNDER 3,000 LBS; B=3,001 - 4,000 LBS C=4,001 - 5,000 LBS
	PRODUCT NUMBER 2=LT20, 3=LT30, 4=LT40, 5=LT40HD 6=LT30HD 7=LT25 8=LT50
	LENGTH OF THE TRAILER 20=20', 24=24'
	NUMBER OF AXLES ON THE TRAILER X IS THE CHECK DIGIT ADD ALL THE NUMBERS AND DIVIDE BY 11
	S IS THE YEAR S=1995, T=1996, V=1997, ETC.
	STATE THE UNIT WAS MANUFACTURED IN N = INDIANA
	A IS THE MONTH UNIT WAS MANUFACTURED A=JAN, B=FEB, C=MAR, ETC.
REVISION LETTER	
SEQUENCE NUMBER RANGING FROM 000-999	

V.I.N. DESCRIPTION.

LT30HD	G24	s
Basic Sawmill I.D.	Engine/Motor Configuration	G.S. Approved

MODEL NUMBER DESCRIPTION.

Table of Contents

Section-Page

SECTION 1	SAFETY & GENERAL INFORMATION	1-1
1.1	Blade Handling	1-1
1.2	Sawmill Setup	1-2
1.3	Sawmill Operation	1-3
1.4	Electric Sawmill	1-5
1.5	Belt Sizes	1-9
1.6	Blade Sizes	1-10
1.7	Cutting Capacity	1-11
1.8	Engine/Motor Specifications	1-12
1.9	Overall Dimensions	1-13
1.10	Components	1-14
1.11	Hydraulic Schematic	1-15
1.12	Hydraulic Components	1-17
1.13	Hydraulic Hoses	1-19
SECTION 2	SETUP & OPERATION	2-1
2.1	Stationary Sawmill Setup	2-1
2.2	Portable Sawmill Setup	2-2
2.3	Preparing The Sawmill For Operation	2-6
2.4	Replacing The Blade	2-7
2.5	Tensioning The Blade	2-8
2.6	Tracking The Blade	2-9
2.7	Starting The Engine (or Motor)	2-11
2.8	Hydraulic Control Operation	2-12
2.9	Loading, Turning, And Clamping Logs	2-16
2.10	Clamp Extension	2-19
2.11	Up/Down Operation	2-20
2.12	Blade Guide Arm Operation	2-21
2.13	Clutch/Brake Operation	2-22
2.14	Power Feed Operation	2-23
2.15	Cutting The Log	2-25
2.16	Edging	2-26
2.17	Blade Height Sight Gauge	2-27
2.18	Blade Height Scale	2-28
2.19	Water Lube Operation	2-31
2.20	Preparing The Sawmill For Towing	2-32

Table of Contents

Section-Page

SECTION 3	MAINTENANCE	3-1
3.1	Wear Life.....	3-1
3.2	Blade Guides	3-2
3.3	Hydraulic Log Loader	3-3
3.4	Blade Housing	3-4
3.5	Carriage Track, Wiper & Scrapers	3-5
3.6	Track Rollers	3-6
3.7	Vertical Mast Rails	3-7
3.8	Drum Switches	3-8
3.9	Miscellaneous Lubrication	3-9
3.10	Blade Tensioner.....	3-10
3.11	Blade Wheel Belts	3-11
3.12	Brake Strap Adjustment	3-12
3.13	Hydraulic System	3-14
3.14	Drive Bearing	3-16
3.15	Up/Down System.....	3-17
3.16	Power Feed	3-20
3.17	Miscellaneous Maintenance	3-22
SECTION 4	TROUBLESHOOTING GUIDE	4-1
4.1	Sawing Problems	4-1
4.2	Electrical Problems.....	4-3
4.3	Power Feed Problems	4-5
4.4	Power Feed Circuit Troubleshooting.....	4-7
4.5	Hydraulic Problems	4-9
4.6	Engine/Motor and Drive Pulleys Alignment.....	4-12
4.7	Power Feed Variable Speed Switch Test.....	4-13
4.8	Power Feed Preliminary Test	4-14
4.9	Power Feed Mechanical Test.....	4-15
4.10	Hydraulic Pressure Test.....	4-16

Table of Contents

Section-Page

SECTION 5	SAWMILL ALIGNMENT	5-1
5.1	Pre-Alignment Procedures.....	5-1
5.2	Frame Setup.....	5-2
5.3	Blade Installation And Alignment.....	5-3
5.4	Saw Head Slide Pad Adjustment.....	5-5
5.5	Adjusting The Lower Track Rollers.....	5-7
5.6	Adjusting Main Bed Rails To Blade	5-9
5.7	Blade Guide Arm Vertical Adjustment	5-11
5.8	Blade Guide Arm Horizontal Adjustment.....	5-12
5.9	Aligning The Blade Guides	5-14
5.10	Blade Deflection.....	5-15
5.11	Blade Guide Vertical Tilt Adjustment.....	5-16
5.12	Blade Guide Spacing	5-18
5.13	Horizontal Tilt Adjustment.....	5-19
5.14	Horizontal Adjustment Of Side Supports.....	5-20
5.15	Vertical Adjustment Of Side Supports	5-21
5.16	Clamp Stop Adjustment	5-22
5.17	Aligning The Pivot Bed Rails.....	5-23
5.18	Sight Gauge Adjustment.....	5-25
5.19	Saw Head Tilt	5-26
5.20	Blade Height Scale Adjustment.....	5-27

SECTION 1 SAFETY & GENERAL INFORMATION



This symbol calls your attention to instructions concerning your personal safety. Be sure to observe and follow these instructions. This symbol accompanies a signal word. The word **DANGER** refers to hazards that can cause death or serious, irreversible personal injury. The word **WARNING** suggests a safety hazard that can cause personal injury. **CAUTION** refers to hazards that can cause damage to the equipment or property only.

Read all safety instructions before operating this equipment and observe all safety warnings!

Safety instructions are listed in this section by the following operations:

- Blade Handling
- Sawmill Setup
- Sawmill Operation
- Electric Sawmill

1.1 Blade Handling



WARNING! Always wear gloves and eye protection when handling bandsaw blades. Keep all persons away from area when coiling or carrying a blade.

1.2 Sawmill Setup



WARNING! Put front outrigger down before moving cutting head from the rest position. Failure to do so may result in serious injury.

WARNING! Do not set up the mill on ground with more than a 10 degree incline. If setup on an incline is necessary, put blocks under one side of the mill or dig out areas for outrigger legs to keep mill level. Setting up the mill on an incline could cause it to tip over, resulting in serious personal injury.

WARNING! Chock the trailer wheels to prevent movement before unhitching it from the towing vehicle. Failure to do so may result in serious injury or death.

WARNING! Always make sure the trailer is supporting the sawmill frame when operating a sawmill with adjustable outriggers. Failure to do so may result in serious injury or death. The adjustable outriggers are intended to support the saw frame with assistance from the trailer.

WARNING! The adjustable outriggers supplied with portable sawmills are not intended for setup on concrete or other hard surfaces. Long-term use of the adjustable outriggers on hard surfaces may cause the outriggers to fail, causing the sawmill to drop. This could result in possible serious injury or death.

If setting the sawmill up on concrete or other hard surface, replace the adjustable outrigger legs with stationary legs.

1.3 Sawmill Operation



DANGER! Never operate or tow the sawmill without all guards and covers in place and secured.

Be sure the blade housing and pulley covers are in place and secure. If applicable, use the safety retainer pin and cable to fasten blade housing covers.

DANGER! Always disengage the clutch/brake mechanism whenever the sawmill is not cutting.

DANGER! Always keep hands away from moving bandsaw blade.

DANGER! Keep all persons a safe distance away from work area when operating sawmill or loading and turning logs.

DANGER! Be sure the power feed switch is in the neutral position before turning the key switch to the ON or ACC position. This prevents unwanted carriage movement.

DANGER! Check to be sure the saw head is resting firmly on the rest pin and mast rail stops and that the safety chain is secured before towing the sawmill.



WARNING! Always secure the cutting head with a 5/16" chain with a least 1900 lbs. working load capacity before adjusting the up/down chain. The cutting head may fall, causing severe injury or death.

WARNING! Always secure the cutting head with a 5/16" chain with a least 1900 lbs. working load capacity before removing the up/down motor belt. The cutting head may fall, causing severe injury or death.

WARNING! Always wear eye, ear, respiration, and foot protection when operating the sawmill.

WARNING! Secure all loose clothing and jewelry before operating the sawmill.

WARNING! Always make sure log is clamped securely before sawing.



CAUTION! Always be sure that all safety warning decals are clean and readable. Replace all damaged warning decals. Contact your local distributor, or call your Customer Service Representative to order more decals.

CAUTION! Be sure the pivot end rails, turning arm, clamp, and toe boards are out of the way before loading a log onto the bed. Also, be sure the cutting head is moved far enough forward so the log does not hit it.

CAUTION! Failure to fully extend the log clamp before towing can result in damage to the clamping assembly during towing.



IMPORTANT! It is always the owner's responsibility to comply with all applicable federal, state and local laws, rules and regulations regarding the ownership, operation and towing of your Wood-Mizer sawmill. All Wood-Mizer mill owners are encouraged to become thoroughly familiar with these applicable laws and comply with them fully while using or towing the mill.

Always properly dispose of all sawing byproducts, including sawdust and other debris.

1.4 Electric Sawmill

USE PROPER PROCEDURE WHEN CONDUCTING ELECTRICAL SAFETY CHECKS AND MAINTENANCE



DANGER! Make sure all electrical installation, service and/or maintenance work is performed by a qualified electrician and is in accordance with applicable electrical codes.

DANGER! Hazardous voltage inside the electric sawmill disconnect box, starter box, and at the motor can cause shock, burns, or death. Disconnect and lock out power supply before servicing! Keep all electrical component covers closed and securely fastened during mill operation.



WARNING! Consider all electrical circuits energized and dangerous.

WARNING! Never assume or take the word of another person that the power is off; check it out and lock it out.

WARNING! Do not wear rings, watches, or other jewelry while working around an open electrical circuit.

WARNING! Before performing service near moving parts such as blades, pulleys, motors, belts and chains, first turn the key switch to the OFF (#0) position and remove the key. If the key is turned on and moving parts activated, serious injury may result.

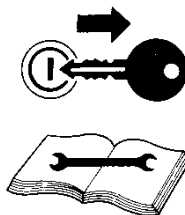

WARNING! Remove the blade before performing any service to the engine or sawmill. Failure to do so may result in serious injury.

DANGER! Lockout procedures must be used during:

- Changing or adjusting blades
- Unjamming operations
- Cleaning
- Mechanical repair
- Electrical maintenance
- Retrieval of tools/parts from work area
- Activities where guards or electrical panel guard is open or removed

Maintenance hazards include:

- Blade contact
- Pinch points
- Kickbacks
- Missiles (thrown blades/wood chips)
- Electrical

Failure to lockout may result in:

- Cut
- Crush
- Blindness
- Puncture
- Serious injury and death
- Amputation
- Burn
- Shock
- Electrocution

To control maintenance dangers:

Lockout procedures must be followed (see ANSI Standard Z244.1-1982 and OSHA regulation 1910.147).

Never rely on machine stop control for maintenance safety (emergency stops, on/off buttons, interlocks).

Do not reach into moving blades or feed systems. Allow all coasting parts to come to a complete stop.

Electrical power supply and air supply must both be locked out.

Where established lockout procedures cannot be used (electrical troubleshooting or mechanical dynamic troubleshooting), alternative effective protective techniques shall be employed which may require special skills and planning.

Always follow safe operations practices in the workplace.

SAWMILL LOCKOUT PROCEDURE

Lockout procedures must be followed (see ANSI Standard Z244.1-1982 and OSHA regulation 1910.147).

Purpose:

This procedure establishes the minimum requirements for lockout of energy sources that could cause injury.

Responsibility:

The responsibility for seeing that this procedure is followed is binding upon all workers. All workers shall be instructed in the safety significance of the lockout procedure. It is your responsibility to ensure safe operation of the machine.

Preparation For Lockout:

Sawmill must be locked out both electrically and pneumatically (lockout air valve).

Sequence of Lockout Procedure:

1. Notify all persons that a lockout is required and the reason therefore.
2. If the Sawmill is operating, shut it down by the normal stopping procedure.
3. Operate the switch and valve so that the energy sources are disconnected or isolated from the Sawmill. Stored energy such as moving blades, feed system and air pressure shall be dissipated.
4. Lockout the energy isolating devices with assigned individual locks.
5. After ensuring that no persons are exposed and as a check on having disconnected the energy sources, operate the push button or other normal operating controls to make certain the Sawmill will not operate. Caution: Return operating controls to neutral position after the test.
6. The Sawmill is now locked out.

Restoring Equipment to Service

1. When the job is complete and the Sawmill is ready for testing or normal service, check the Sawmill area to see that no one is exposed.
2. When the Sawmill is all clear, remove all locks. The energy isolating devices may be operated to restore energy to the Sawmill.

Procedure Involving More Than One Person

In the preceding steps, if more than one individual is required to lock out the Sawmill, each shall place his own personal lock on the energy isolating devices.

Rules for Using Lockout Procedure

The Sawmill shall be locked out to protect against accidental or inadvertent operation when such operation could cause injury to personnel. Do not attempt to operate any switch or valve bearing a lock.

Owner's Responsibility

The procedures listed in this manual may not include all ANSI, OSHA, or locally required safety procedures. It is the owner/operator's responsibility and not Wood-Mizer Products to ensure all operators are properly trained and informed of all safety protocols. Owner/Operators are responsible for following all safety procedures when operating and performing maintenance to the Sawmill.

1.5 Belt Sizes

See Table 1-1. Belt sizes for the LT30HD/40HD are shown.

Description	Belt Size	Wood-Mizer Part #
24hp Gas Engine Drive Belt	2BX74 ²	P10277-2
20hp Diesel Engine Drive Belt	2BX68 ²	P12139-2
15hp Electric Motor Drive Belt	2BX70 ²	P04857-2
Alternator Belt (G24)	A33	P11542
Alternator Belt (D20/E15)	A30	P11628
Blade Pulley Belts	B57 ¹	P04185
Power Feed Drive Belt	4L280	P04031
Up/Down Drive Belt	3L290	P04349
¹ To insure proper blade tracking, use Goodyear, Dayco Super II, or Browning belts only. ² Two belts originally supplied on machines prior to rev E3. Replace with one common-backed belt as listed above.		

TABLE 1-1

1 Safety & General Information

Blade Sizes

1.6 Blade Sizes

See Table 1-2. Wood-Mizer TRU•SHARP™ offers three types of blades to provide efficient sawing for all models of sawmills. The engine/motor size of your sawmill and the type of wood you saw should determine which blade you choose for optimum performance.

Gas/Diesel Engine Size	Recommended Blade For Sawing:		
	Softwood	Hardwood	Frozen or Hard-to-Cut Wood
5 hp - 14hp	.042 x 7/8 x 1 1/4"	.035 x 7/8 x 1 1/4"	.045 x 7/8 x 1 1/4" F ¹
16hp or more	.045 x 7/8 x 1 1/2"	.042 x 7/8 x 1 1/4" .045 x 7/8 x 1 1/2" ²	.045 x 7/8" x 1 1/4" F1
Electric Motor	.045 x 7/8 x 1 1/2"	.042 x 7/8 x 1 1/4" .045 x 7/8 x 1 1/2" ²	.045 x 7/8 x 1 1/4" F1

TABLE 1-2

¹ TRU•SHARP™ "F" blades use a 9/29 profile (9° hook angle and 29° back angle) and are designed to cut frozen and/or extremely dense, hard-to-cut wood. Standard TRU•SHARP™ blades use a 10/30 profile.

² Customer may choose preferred blade.

[See The Blade Handbook](#) for blade hook angle, tooth height, and tooth set specifications.

1.7 Cutting Capacity

See Table 1-3. The log size capacities of the LT30HD and LT40HD sawmills are listed below.

	Max. Diameter ¹	Max. Length ¹
LT30HD	36" (91.5 cm) ²	16' 8" (5.1 m)
LT40HD	36" (91.5 cm) ²	21' (6.4 m)
LT30HD with Optional 12' Bed Extension ³	36" (91.5 cm) ²	28' 8" (8.7 m)
LT40HD with Optional 12' Bed Extension ³	36" (91.5 cm) ²	33' (10.1 m)

TABLE 1-3

¹ Maximum log capacity for a basic mill is 4400 lbs. (1996 Kg).

² Maximum diameter capacity prior to revision C8 is 32"

³ Logs over 4400 lbs. must be distributed so that neither the basic mill or extension is loaded beyond the 4400 lb. maximum weight rating. Loading logs heavier than 4400 lbs. (1996 Kg.) on a mill equipped with bed extension requires auxiliary log handling equipment.

See Table 1-4. The production capacity of the LT30HD and LT40HD sawmills is listed below. Productivity is based on sawing 1" lumber. The low end of the range is based on a single operator with no support equipment. The high end of the range is based on two operators with support equipment.

Model	Production Capacity
LT30HD/40HD 24hp gas engine	2,000 - 3,400 bdf./day
LT30HD/40HD 15hp electric motor	2,000 - 3,400 bdf./day
LT30HD/40HD 20hp diesel engine	2,000 - 3,200 bdf./day

1.8 Engine/Motor Specifications

See Table 1-5. The power options available for the LT30HD and LT40HD sawmills are listed below.

Engine/Motor Type	Manufacturer	Model Number
24HP Gasoline	Onan	P224
20HP Diesel	Acme	ADX740
15HP Electric	Baldor	Custom

TABLE 1-5

1.9 Overall Dimensions

See Table 1-6. The overall dimensions of the LT30HD sawmill are listed below.

	LT30HD	LT30HD with Surge Brake Trailer Pkg.
Length	19' 11" (5.3 m)	21' 9" (6.6 m)
Width	8' (2.4 m)	8' 2" (2.5 m)
Height	7' 6" (2.3 m)	7' 6" (2.3 m)
Weight	2433 lbs. (1105 Kg)	2780 lbs. (1262 Kg)

TABLE 1-6

See Table 1-7. The overall dimensions of the LT40HD sawmill are listed below.

	LT40HD	LT40HD with Surge Brake Trailer Pkg.
Length	24' 4" (7.4 m)	26' 2" (8.0 m)
Width	8' (2.4 m)	8' 2" (2.5 m)
Height	7' 6" (2.3 m)	7' 6" (2.3 m)
Weight	2513 lbs. (1141 Kg)	2860 lbs. (1298 Kg)

1.10 Components

See **Figure 1-1**. The major components of the Wood-Mizer LT30HD/LT40HD are shown below.

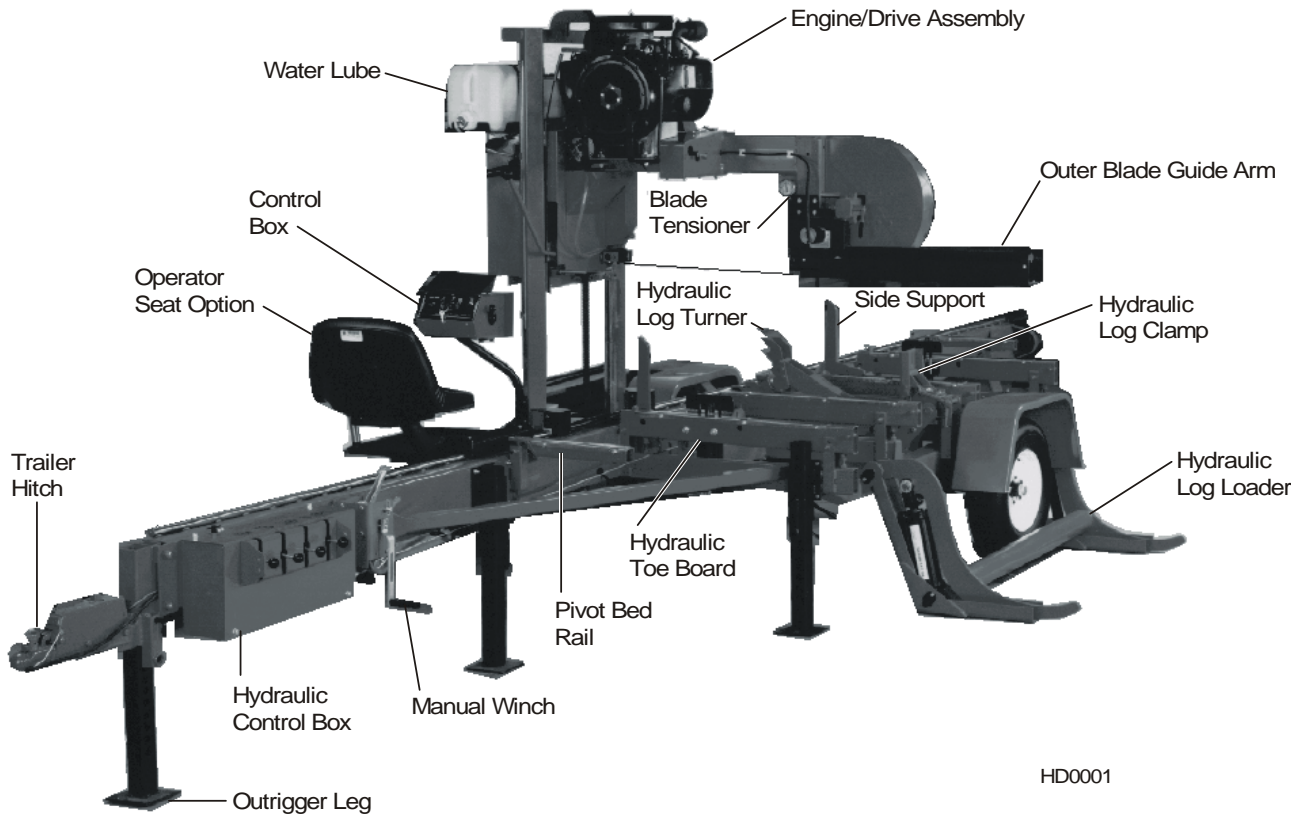

FIG. 1-1

1.11 Hydraulic Schematic

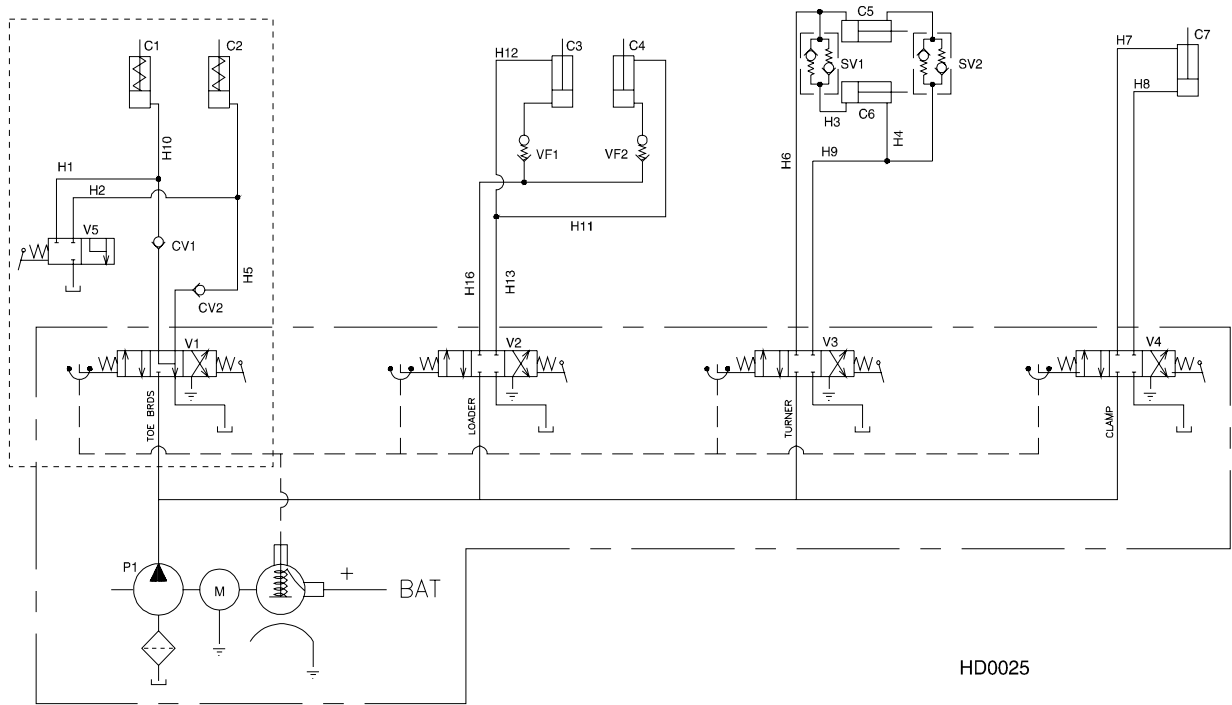

FIG. 1-2 HYDRAULIC SCHEMATIC (REVISIONS E7+).

1 Safety & General Information
Hydraulic Schematic

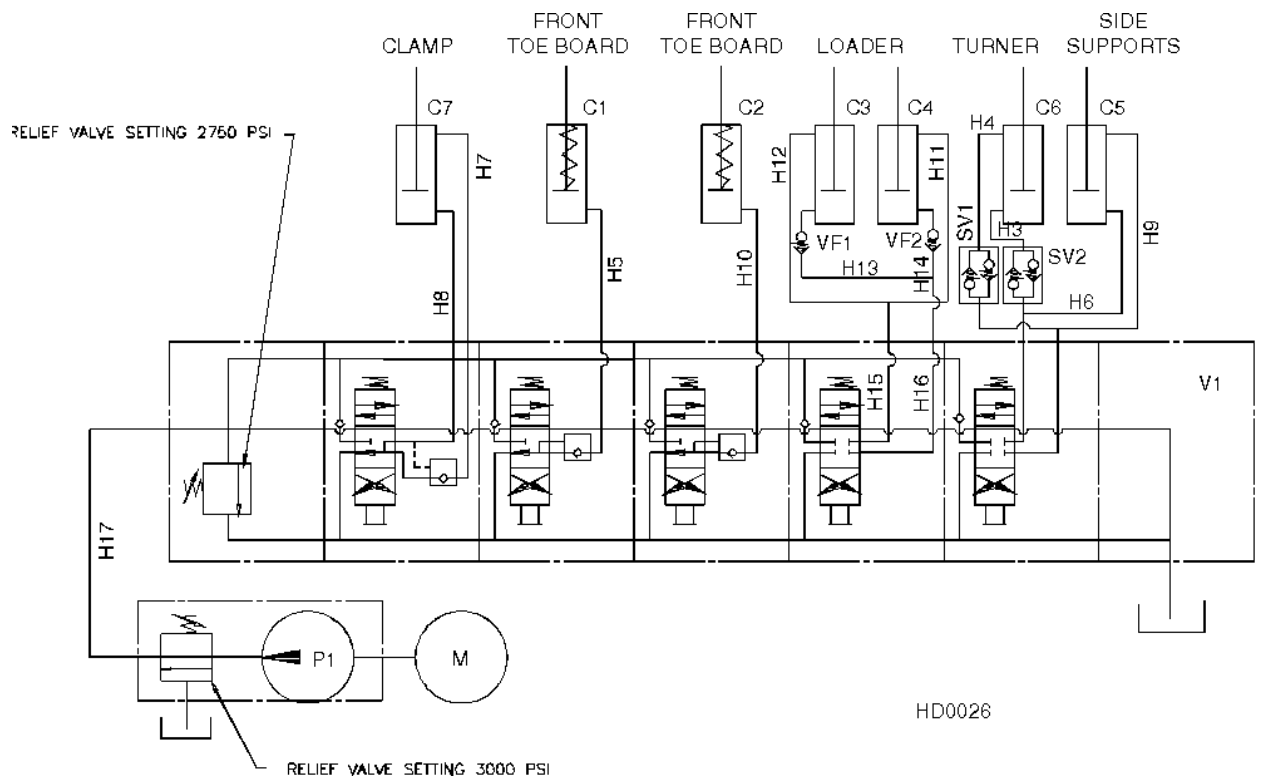

FIG. 1-3 HYDRAULIC SCHEMATIC (REVISIONS C7 - E6).

1.12 Hydraulic Components

REVISIONS E7+

Component	Mfg. Part No.	Manufacturer	Wood-Mizer Part.#	Description
C1	A09665	Wood-Mizer	A09665	Hydraulic Cylinder, 1.5" Bore X 3.5" Stroke, Spring Return
C2	A09665	Wood-Mizer	A09665	Hydraulic Cylinder, 1.5" Bore X 3.5" Stroke, Spring Return
C3	P12847	J-D Hydraulic	P12847 ¹	Hydraulic Cylinder, 3" Bore X 8" Stroke (Rev. F5+)
	TQ3008 Q0002	Monarch Can.	P09128 ²	Hydraulic Cylinder, 3" Bore X 8" Stroke (Rev. E7 - F4)
	TQ3008 Q0002	Monarch Can.	P09128 ²	Hydraulic Cylinder, 3" Bore X 8" Stroke (Rev. E7 - F4)
C5	P12845	J-D Hydraulic	P12845 ³	Hydraulic Cylinder, 2" Bore X 6" Stroke
C6	P12846	J-D Hydraulic	P12846 ⁴	Hydraulic Cylinder, 2.5" Bore X 6" Stroke
C7	P12847	J-D Hydraulic	P12847 ¹	Hydraulic Cylinder, 3" Bore X 8" Stroke
P1		Monarch Hyd.	N/A	Hydraulic Pump, Motor Driven
SV1	A09207	Wood-Mizer	A09207	Sequence Valve
SV2	A09207	Wood-Mizer	A09207	Sequence Valve
V1	07129	Monarch Hyd.	P12700	Valve, 5-Valve Salami
VF1	28000-502-2.5	Vonberg	P11566	Valve, Hydraulic Velocity Fuse
VF2	28000-502-2.5	Vonberg	P11566	Valve, Hydraulic Velocity Fuse
M	08058 ⁵	Monarch Hyd.	P09955 ⁶	Motor, Hydraulic Pump

¹ Welded cylinder P12847 replaces tie rod cylinder P09128 originally supplied before Rev. F5.

² Use tie rod cylinder P09128 for Rev. C7 - F4.

³ Welded cylinder P12845 replaces tie rod cylinder P09125 originally supplied before Rev. F5.

⁴ Welded cylinder P12846 replaces tie rod cylinder P09127 originally supplied before Rev. F5

⁵ Replaces Monarch #08111 originally supplied before 8/94.

⁶ Bosch motor P09955 replaced by vendor with Iksra motor 1/06. Brush kit P09585 no longer available to service Bosch motor. Replace motor using kit 052807. Use Brush Kit 038682 to service Iksra motor.

1

Safety & General Information

Hydraulic Components

REVISIONS C7 - E6

Component	Manufacturer Part No.	Manufacturer	Wood-Mizer Part No.	Description
C1	A09665	Wood-Mizer	A09665	Hydraulic Cylinder, 1.5" Bore X 3.5" Stroke, Spring Return
C2	A09665	Wood-Mizer	A09665	Hydraulic Cylinder, 1.5" Bore X 3.5" Stroke, Spring Return
C3	TQ3008 Q0002	Monarch Can.	P09128	Hydraulic Cylinder, 3" Bore X 8" Stroke
C4	TQ3008 Q0002	Monarch Can.	P09128	Hydraulic Cylinder, 3" Bore X 8" Stroke
C5	P12845	J-D Hydraulic	P12845 ¹	Hydraulic Cylinder, 2" Bore X 6" Stroke
C6	P12846	J-D Hydraulic	P12846 ²	Hydraulic Cylinder, 2.5" Bore X 6" Stroke
C7	P12847	J-D Hydraulic	P12847 ³	Hydraulic Cylinder, 3" Bore X 8" Stroke
CV1	A11687	Wood-Mizer	A11687	Check Valve
CV2	A11687	Wood-Mizer	A11687	Check Valve
P1	O2414	Monarch Hyd.	N/A	Hydraulic Pump, Motor Driven
SV1	A09207	Wood-Mizer	A09207	Sequence Valve
SV2	A09207	Wood-Mizer	A09207	Sequence Valve
V1	00647	Monarch Hyd.	P11581	Valve, 4-way Manually Operated (Integral Part Of P/N P10371)
V2	00524	Monarch Hyd.	P10143	Valve, 4-way Manually Operated (Integral Part Of P/N P10371)
V3	00524	Monarch Hyd.	P10143	Valve, 4-way Manually Operated (Integral Part Of P/N P10371)
V4	00524	Monarch Hyd.	P10143	Valve, 4-way Manually Operated (Integral Part Of P/N P10371)
V5	A09680	Wood-Mizer	A09680	Dump Valve, Manually Operated
VF1	28000-502-2.5	Vonberg	P11566	Valve, Hydraulic Velocity Fuse
VF2	28000-502-2.5	Vonberg	P11566	Valve, Hydraulic Velocity Fuse
M	08058 ⁴	Monarch Hyd.	P09955 ⁵	Motor, Hydraulic Pump

¹ Welded cylinder P12845 replaces tie rod cylinder P09125 originally supplied.

² Welded cylinder P12846 replaces tie rod cylinder P09127 originally supplied.

³ Welded cylinder P12847 replaces tie rod cylinder P09128 originally supplied.

⁴ Replaces Monarch #08111 originally supplied.

⁵ Bosch motor P09955 replaced by vendor with Iksra motor 1/06. Brush kit P09585 no longer available to service Bosch motor. Replace motor using kit 052807. Use Brush Kit 038682 to service Iksra motor.

1.13 Hydraulic Hoses

REVISIONS F5+

Component	Color Code	Application	Wood-Mizer Part No.	Description
H3	Plain	Log Turner Cylinder Base	P12533	Hose, 1/4" X 14" Hydraulic W/Fittings
H4	Orange	Log Turner Cylinder Top	P12535	Hose, 1/4" X 27" Hydraulic W/Fittings
H5	Yellow	Front Toe Board (LT30HD)	P12539	Hose, 1/4" X 84" Hydraulic W/Fittings
	Yellow	Front Toe Board (LT40HD)	P12541	Hose, 1/4" X 106" Hydraulic W/Fittings
H6	Pink	Side Support Cylinder Base (LT30HD)	P12545	Hose, 1/4" X 151" Hydraulic W/Fittings
	Pink	Side Support Cylinder Base (LT40HD)	P12549	Hose, 1/4" X 173" Hydraulic W/Fittings
H7	White	Clamp Cylinder Top (LT30HD)	P12544	Hose, 1/4" X 142" Hydraulic W/Fittings
	White	Clamp Cylinder Top (LT40HD)	P12548	Hose, 1/4" X 164" Hydraulic W/Fittings
H8	Dark Orange	Clamp Cylinder Base (LT30HD)	P12543	Hose, 1/4" X 135" Hydraulic W/Fittings
	Dark Orange	Clamp Cylinder Base (LT40HD)	P12546	Hose, 1/4" X 157" Hydraulic W/Fittings
H9	Plain	Side Support Cylinder Top (LT30HD)	P12547	Hose, 1/4" X 159" Hydraulic W/Fittings
	Plain	Side Support Cylinder Top (LT40HD)	P12550	Hose, 1/4" X 186" Hydraulic W/Fittings
H10	Purple	Rear Toe Board (LT30HD)	P12549	Hose, 1/4" X 173" Hydraulic W/Fittings
	Purple	Rear Toe Board (LT40HD)	P12551	Hose, 1/4" X 197" Hydraulic W/Fittings
H11	Green	Loading Arm Branch Top	P12537	Hose, 1/4" X 50" Hydraulic W/Fittings
H12	Green	Loading Arm Branch Top	P12537	Hose, 1/4" X 50" Hydraulic W/Fittings
H13	Yellow	Loading Arm Branch Base	P12538	Hose, 1/4" X 55" Hydraulic W/Fittings
H14	Yellow	Loading Arm Branch Base	P12538	Hose, 1/4" X 55" Hydraulic W/Fittings

1 Safety & General Information

Hydraulic Hoses

REVISIONS F5+

H15	Blue	Loading Arm Cylinder Top (LT30HD)	P12545	Hose, 1/4" X 151" Hydraulic W/Fittings
	Blue	Loading Arm Cylinder Top (LT40HD)	P12549	Hose, 1/4" X 173" Hydraulic W/Fittings
H16	Red	Loading Arm Cylinder Bottom (LT30HD)	P12545	Hose, 1/4" X 151" Hydraulic W/Fittings
	Red	Loading Arm Cylinder Bottom (LT40HD)	P12549	Hose, 1/4" X 173" Hydraulic W/Fittings
H17	None	Hydraulic Pump To Valve	P12705	Hose, 3/8" X 22" Hydraulic W/Fittings

REVISIONS C7 - F4

Component	Color Code	Application	Wood-Mizer Part No.	Description
H1	Brown	Toe Board Return (Rev. C7- E6 Only)	P12534	Hose, 1/4" X 22" Hydraulic W/Fittings
H2	Brown	Toe Board Return (Rev. C7- E6 Only)	P12534	Hose, 1/4" X 22" Hydraulic W/Fittings
H3	Gold	Log Turner Cylinder Base	P12533	Hose, 1/4" X 14" Hydraulic W/Fittings
H4	Grey	Log Turner Cylinder Top	P12535	Hose, 1/4" X 27" Hydraulic W/Fittings
H5	Bright Yellow	Front Toe Board (LT30HD)	P12539	Hose, 1/4" X 84" Hydraulic W/Fittings
	Bright Yellow	Front Toe Board (LT40HD)	P12541	Hose, 1/4" X 106" Hydraulic W/Fittings
H6	Silver	Side Support Cylinder Base (LT30HD)	P12545	Hose, 1/4" X 151" Hydraulic W/Fittings
	Silver	Side Support Cylinder Base (LT40HD)	P12549	Hose, 1/4" X 173" Hydraulic W/Fittings
H7	White	Clamp Cylinder Top (LT30HD)	P12544	Hose, 1/4" X 142" Hydraulic W/Fittings
	White	Clamp Cylinder Top (LT40HD)	P12548	Hose, 1/4" X 164" Hydraulic W/Fittings
H8	Orange	Clamp Cylinder Base (LT30HD)	P12543	Hose, 1/4" X 135" Hydraulic W/Fittings
	Orange	Clamp Cylinder Base (LT40HD)	P12546	Hose, 1/4" X 157" Hydraulic W/Fittings
H9	Plain	Side Support Cylinder Top (LT30HD)	P12547	Hose, 1/4" X 159" Hydraulic W/Fittings
	Plain	Side Support Cylinder Top (LT40HD)	P12550	Hose, 1/4" X 186" Hydraulic W/Fittings
H10	Black	Rear Toe Board (LT30HD)	P12549	Hose, 1/4" X 173" Hydraulic W/Fittings
	Black	Rear Toe Board (LT40HD)	P12551	Hose, 1/4" X 208" Hydraulic W/Fittings
H11	Dark Green	Loading Arm Branch Top	P12537	Hose, 1/4" X 52" Hydraulic W/Fittings
H12	Dark Green	Loading Arm Branch Top	P12537	Hose, 1/4" X 52" Hydraulic W/Fittings
H13	Dark Yellow	Loading Arm Branch Base	P12538	Hose, 1/4" X 55" Hydraulic W/Fittings
H14	Dark Yellow	Loading Arm Branch Base	P12538	Hose, 1/4" X 55" Hydraulic W/Fittings

1 Safety & General Information

Hydraulic Hoses

REVISIONS C7 - F4

H15	Blue	Loading Arm Cylinder Top (LT30HD)	P12545	Hose, 1/4" X 151" Hydraulic W/Fittings
	Blue	Loading Arm Cylinder Top (LT40HD)	P12549	Hose, 1/4" X 173" Hydraulic W/Fittings
H16	Red	Loading Arm Cylinder Bottom (LT30HD)	P12545	Hose, 1/4" X 151" Hydraulic W/Fittings
	Red	Loading Arm Cylinder Bottom (LT40HD)	P12549	Hose, 1/4" X 173" Hydraulic W/Fittings
H17	None	Hydraulic Pump To Valve (Rev. E7+Only)	P12705	Hose, 3/8" X 22" Hydraulic W/Fittings

SECTION 2 SETUP & OPERATION

2.1 Stationary Sawmill Setup

See **Figure 2-1**. Set up the mill on firm footing. Level by eye. Fasten the mill to the floor or platform, or tie down to footing to stop any creep after prolonged use.

NOTE: Make sure the unit is level before securing. It IS possible to twist the mill frame by jacking one foot higher than the others.

! **DANGER!** Do not operate a stationary sawmill without the feet securely fastened to the floor. If the feet are not securely fastened, loading and turning large logs could cause the sawmill to tip over.

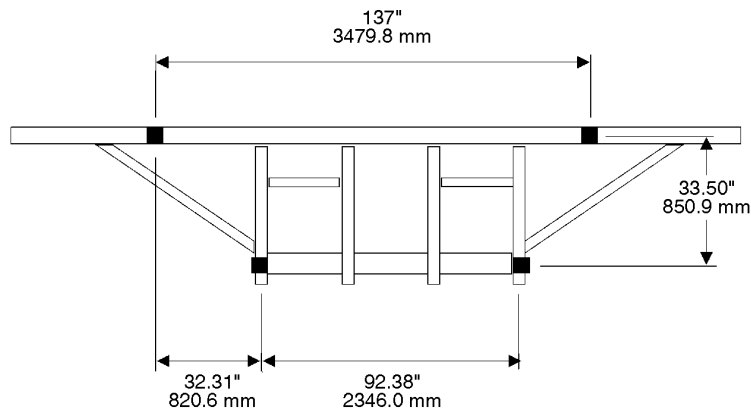

LT30/LT30HD FOOT SPACING

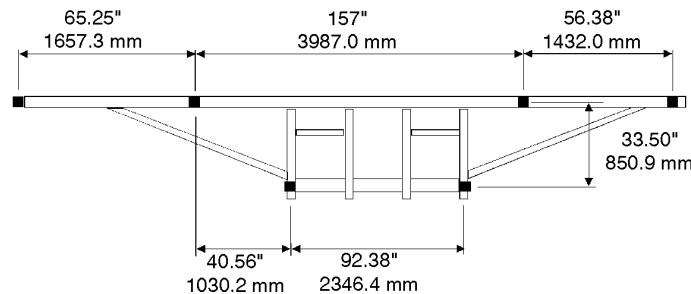

LT40/LT40HD FOOT SPACING

3H0001

FIG. 2-1

*NOTE Rear leg standard on LT40/LT40HD after 3/92. Rear leg or outrigger may be retrofitted to previous models.

2.2 Portable Sawmill Setup



WARNING! Do not set up the mill on ground with more than a 10 degree incline. If setup on an incline is necessary, put blocks under one side of the mill or dig out areas for outrigger legs to keep mill level. Setting up the mill on an incline could cause it to tip over, resulting in serious personal injury.

WARNING! Chock the trailer wheels to prevent movement before unhitching it from the towing vehicle. Failure to do so may result in serious injury or death.

WARNING! Always make sure the trailer is supporting the sawmill frame when operating a sawmill with adjustable outriggers. Failure to do so may result in serious injury or death. The adjustable outriggers are intended to support the saw frame with assistance from the trailer.

WARNING! The adjustable outriggers supplied with portable sawmills are not intended for setup on concrete or other hard surfaces. Long-term use of the adjustable outriggers on hard surfaces may cause the outriggers to fail, causing the sawmill to drop. This could result in possible serious injury or death.

If setting the sawmill up on concrete or other hard surface, replace the adjustable outrigger legs with stationary legs.

1. Unhitch the mill from the vehicle.

See Figure 2-2.

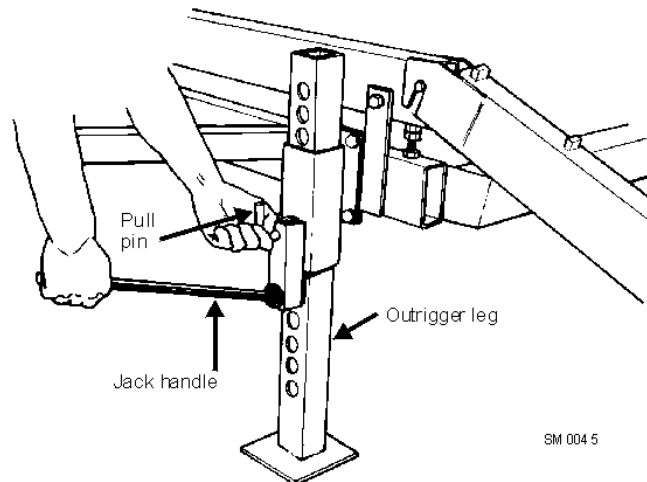



FIG. 2-2

2. Lower and set the front three outriggers. Lift the weight from the locking pin using the jack handle. Pull the locking pin to release the outrigger and lower the outrigger as necessary. Secure with the locking pin.

 **WARNING!** Put front outrigger down before moving cutting head from the rest position. Failure to do so may result in serious injury.

For Fine Adjust Outriggers (FAOs), lower the outrigger as close to the ground as possible, then secure in place with the locking pin. Adjust the outrigger base so that it contacts the ground. To adjust, use the provided wrench to turn the height adjustment nut. Turn clockwise to lower. Turn counterclockwise to raise. Maximum adjustment available is 1 1/2" (3.8 cm).

 **CAUTION!** Do not adjust the FAO outrigger base height while there is weight on the FAO. Damage to the FAO may result.

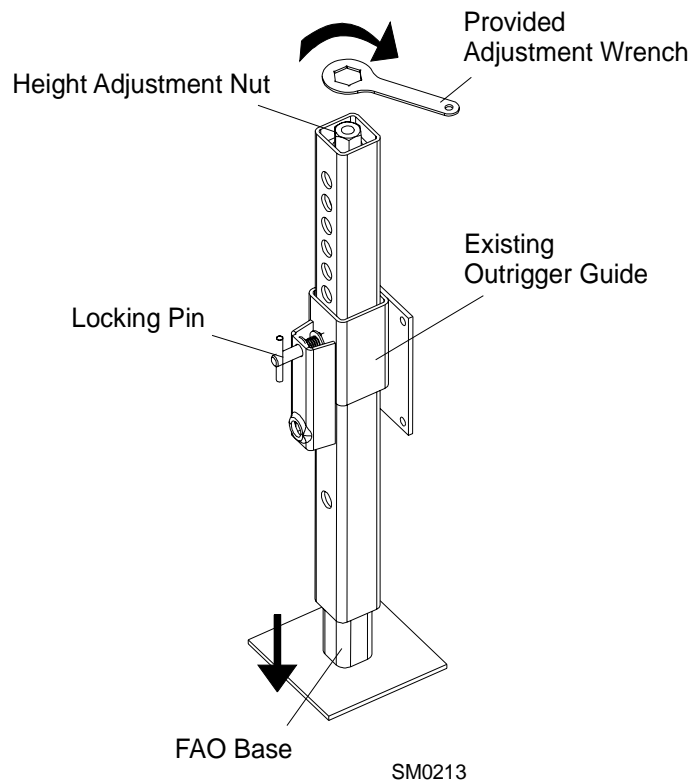

FIG. 2-2. BASE HEIGHT ADJUSTMENT (FOR FINE ADJUST OUTRIGGER ONLY).

3. Unhook the carriage safety chain.
4. Start the engine to enable the battery-operated accessories ([See Section 2.7](#)). Use the up/down switch on the control panel to raise the cutting head from the carriage rest pin. Remove the locking pin and swing the rest pin down below bed level.



CAUTION! Always make sure the engine is running before operating the sawmill controls. Operating the controls without the engine running will result in power drainage from the battery.

5. Use the carriage fwd/rev switch (left side of control box) to move the cutting head toward the front end of the mill. The hydraulic control levers become operational when the contacts at the bottom of the carriage touch the power strip on the frame tube. The hydraulic control levers will only work when the cutting head is close enough to the front end of the mill to touch the power strip.

Lower and set the remaining rear outriggers.

6. Level the sawmill by adjusting the outriggers to raise or lower each end of the sawmill. Adjust all outriggers evenly to avoid twisting the mill frame by jacking one outrigger higher than the others.

For FAO(s), fine tune the outrigger base height as necessary. Move the cutting head to the opposite end of the mill from the outrigger. Raise the entire outrigger (to remove the sawmill weight from it) and adjust the outrigger base as necessary. Lower the entire outrigger and use the locking pin to secure in position.



CAUTION! Do not adjust the FAO outrigger base height while there is weight on the FAO. Damage to the FAO may result.

7. Remove the fenders by lifting them out of the slots.



CAUTION! To prevent fender damage, remove fenders before operating sawmill or loading logs.

8. Raise the two side supports that will prevent a log from falling off the side of the mill when loaded.

See Figure 2-3.

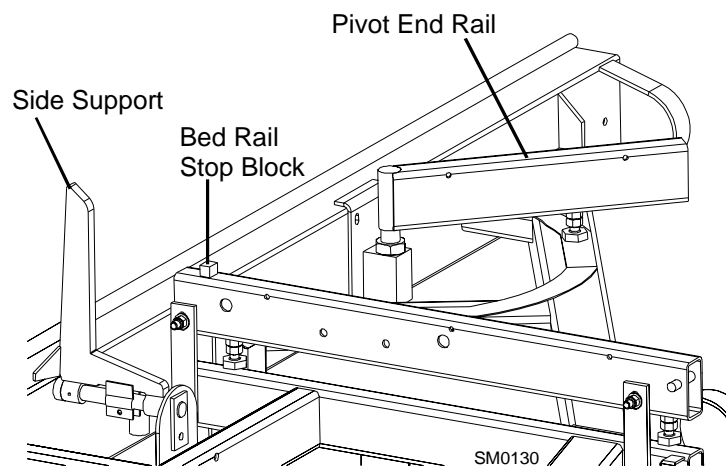

FIG. 2-3

2.3 Preparing The Sawmill For Operation

1. TUV Trailers only:

See Figure 2-4. Disassemble the perimeter fence. Remove the six locking pins and two hold-down nuts. Unplug the tail light board from the auxiliary adapter. Remove all four sections of the perimeter fence.

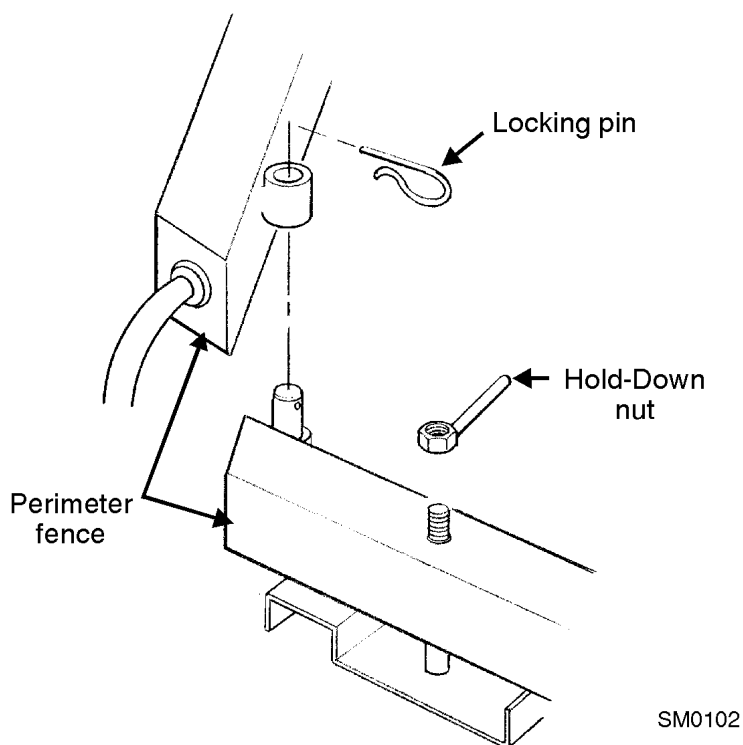

FIG. 2-4

Adjust the jockey wheel down by turning the crank clockwise until the wheel is planted firmly on the ground. Set the brake by pushing the lever away from the hitch coupler. [See *Trailer Option Manual*](#) for TUV trailer hitch operation.

2.4 Replacing The Blade



WARNING! Always wear gloves and eye protection whenever handling bandsaw blades. Changing blades is safest when done by one person! Keep all other persons away from work area when changing blades. Do not change the blade with the engine running.

See Figure 2-5. Remove the blade housing cover(s) that are over the drive wheels. Turn the tension handle to release the blade tension until the wheel is pulled in and the blade is lying loose in the blade housing. Lift the blade out of the blade housing.

When installing a blade, make sure the teeth are pointing the correct direction. The teeth should be pointing toward the operator side of the mill when you are looking at the blade below the blade guides. Install the blade so it is lying around the wheels.

Position 1 1/4" wide blades on the wheels so the gullet is 1/8" (3.0 mm) out from the edge of the wheel. Position 1 1/2" wide blades on the wheels so the gullet is 3/16" (4.5 mm) out from the edge of the wheel.

Close the middle blade housing cover.

Next, turn the tension handle until the blade is tensioned correctly.

2.5 Tensioning The Blade

See **Figure 2-5**. Tension the blade by turning the hydraulic tensioning handle clockwise until the tension gauge indicates the recommended tension.

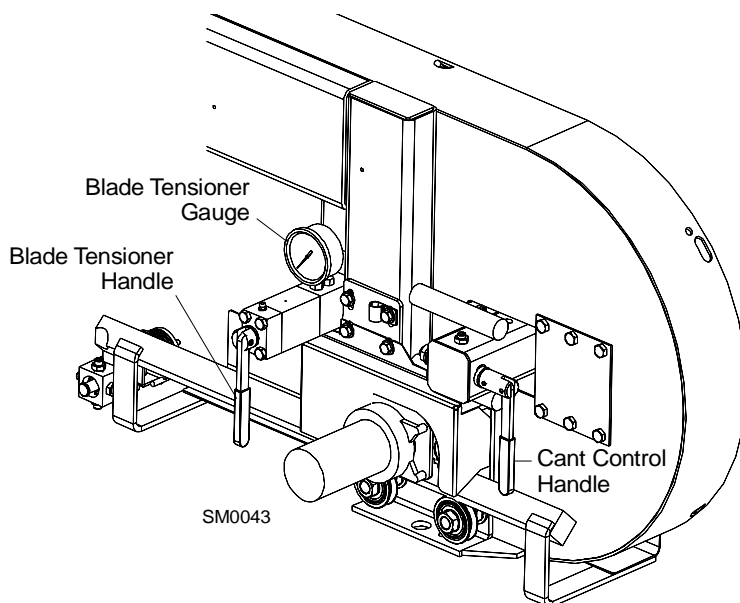

FIG. 2-5

See **Table 2-1**. The recommended tensions for different blades is shown below.

Blade Type	Acceptable Range	Ideal Tension
.035" x 7/8" x 1 1/4"	1800 - 2100 psi	2000 psi
.042" x 7/8" x 1 1/4"	2100 - 2400 psi	2300 psi
.045" x 7/8" x 1 1/2"	2100 - 2400 psi	2300 psi

TABLE 2-1

The tension gauge should be checked occasionally when adjusting the cant control or while cutting. Ambient temperature changes will cause tension to change. Adjust the tension handle as necessary to maintain the recommended tension level.



CAUTION! The blade tension should be released when the mill is not in use. Changes in temperature could cause increased pressure in the tensioner and loss of fluid from the gauge.

2.6 Tracking The Blade

Make sure the middle blade housing cover is closed and all persons are clear of the open side of the saw head.

Start the engine (or motor). Pull lightly on the clutch handle, rotating the blade until the blade positions itself on the wheels.

See Figure 2-6. Position 1 1/4" wide blades so the gullet is 1/8" (3.0 mm) out from the edge of the blade wheel ($\pm 1/32$ [.75 mm]). Position 1 1/2" blades so the gullet is 3/16" (4.5 mm) out from the edge of the blade wheel ($\pm 1/32$ [.75 mm]).

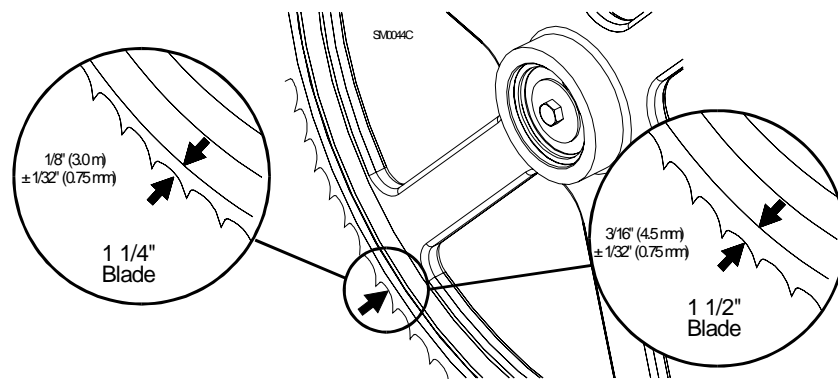

FIG. 2-6

To adjust where the blade travels on the blade wheels, use the cant control handle shown in **Figure 2-5**.

If the blade is too far out, back the blade onto the wheel by turning the cant control counterclockwise. If the blade is too far in, turn the cant control clockwise until the gullet of the blade is the correct distance from the front edge of the wheel.

2

Setup & Operation

Tracking The Blade

Retension the blade to the recommended tension to compensate for any adjustments you have made in the cant control. Replace the covers.



DANGER! Never operate the sawmill without all guards and covers in place and secured.

Be sure the blade housing and pulley covers are in place and secure. If applicable, use the safety retainer pin and cable to fasten blade housing covers.



IMPORTANT! After aligning the blade on the wheels, always double-check the blade guide spacing and location. [See Section 5](#) for more information.

2.7 Starting The Engine (or Motor)

See the appropriate manual supplied with your specific engine/motor configuration for starting and operating instructions.



DANGER! Read the entire manual before operating your Wood-Mizer sawmill.

DANGER! Never operate the sawmill without all guards and covers in place and secured.

Be sure the blade housing and pulley covers are in place and secure before starting the sawmill. If applicable, use the safety retainer pin and cable to fasten blade housing covers.

DANGER! Do not start the engine or motor when the clutch/brake lever is in the engaged (down) position. Always be sure the blade is disengaged and all persons are away from the blade before starting the engine.

DANGER! Make sure the carriage fwd/rev switch is in the neutral position before turning the key switch to the ON or ACC position. This will prevent unintended carriage movement.



WARNING! Always wear eye, ear, and respiration protection when operating this equipment.

2.8 Hydraulic Control Operation

Revisions E7+

See **Figure 2-7**. Use the five control levers to do the following steps. This gets the mill ready to load a log.

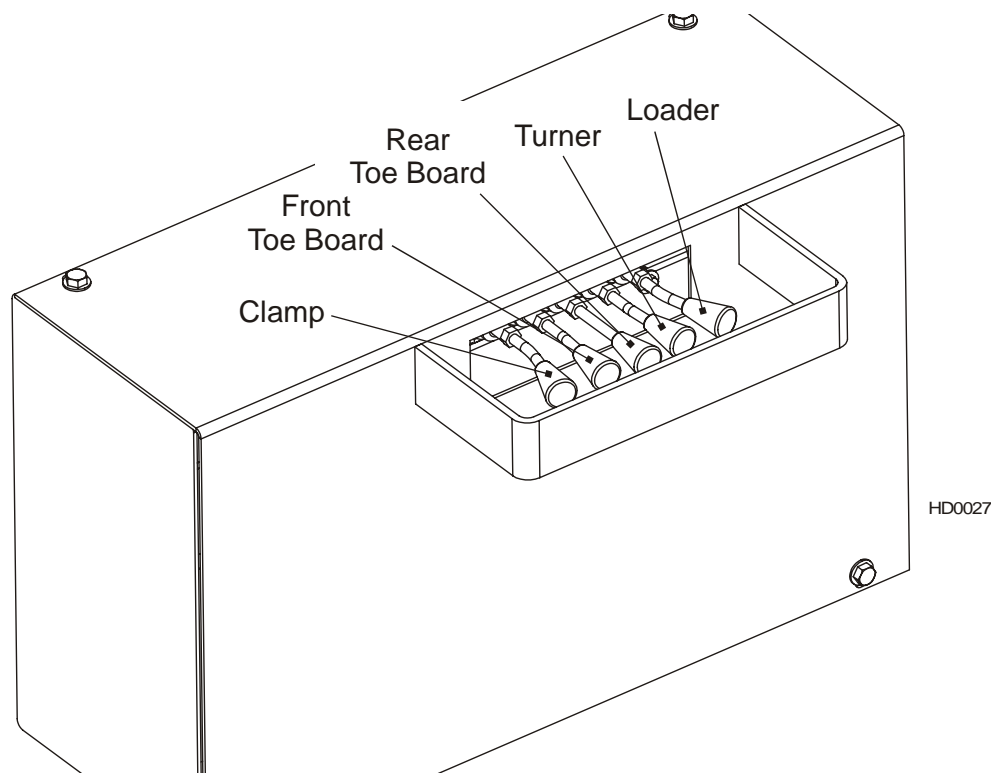

FIG. 2-7

Revisions C7 - E6

See **Figure 2-8**. Use the four control levers to do the following steps. This gets the mill ready to load a log.

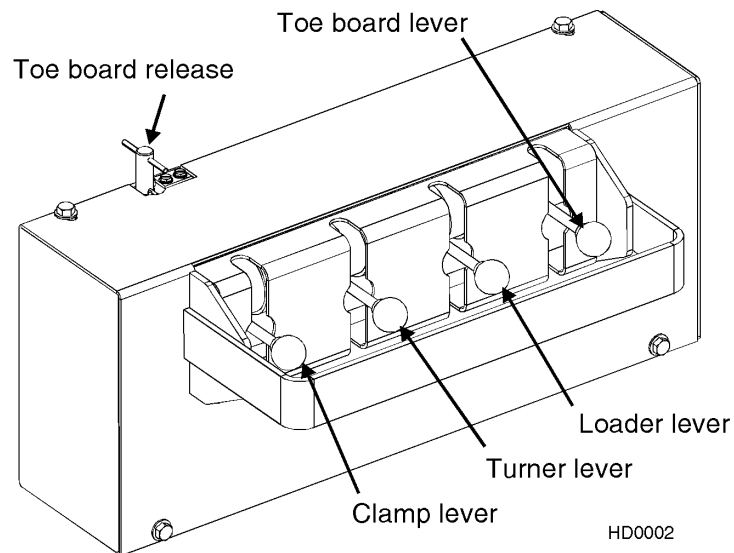

FIG. 2-8



CAUTION! Never operate the hydraulic controls without the engine running. Power drainage from the battery will result. Holding the hydraulic switches halfway up or down also will cause excessive drainage from the battery.



DANGER! Keep all persons a safe distance away while operating the sawmill. Leave loading arm halfway up while log is on sawmill bed.

1. Lower the clamp lever to move the log clamp toward the loading side of the mill. Be sure the clamp is in the down position so it will not get in the way of logs being loaded onto the bed.

See **Figure 2-9**. The two-stage clamp can be raised or lowered by lowering the clamp lever and moving the clamp all the way out. The clamp will engage the flip arm and flip the clamp in either the up or down position.

A 3" clamp extension is located at the end of the clamp assembly or inside the battery box of all hydraulic sawmills. The extension is used for small logs or boards needing a shorter

2 Setup & Operation

Hydraulic Control Operation

clamp. [See Section 2.10](#)

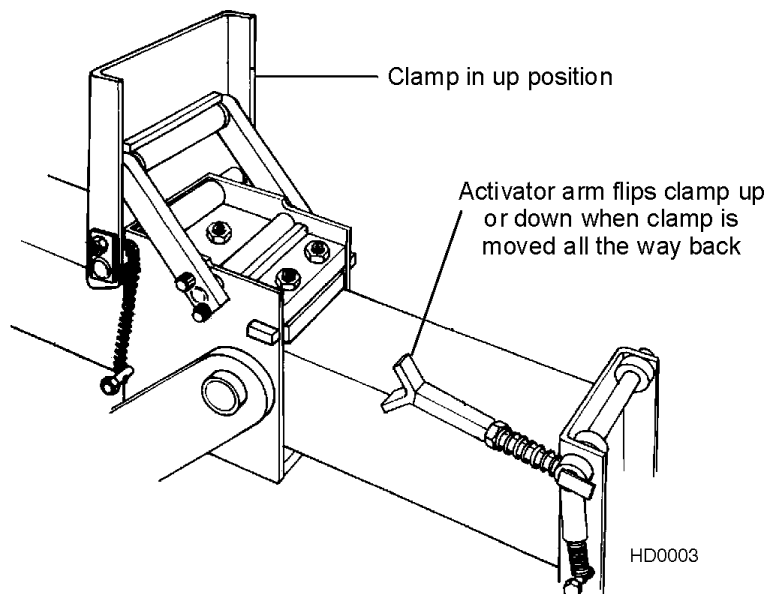

FIG. 2-9

2. Raise the log loader lever to extend the legs of the log loader out as far as they will go.
3. The chain securing the log loading arm to the log turner arm will be tight. Raise the log turner lever to raise the turner arm until there is slack in the chain.
4. Unchain the loading arm from the turner arm.
5. Lower the turner lever to completely lower the turner arm. Notice that after the turner arm is all the way down, the side support braces will begin to lower. Release the turner lever after the turner arm is lowered, but before the side supports begin to lower. This stops the log being loaded from damaging the turner and/or falling off the side of the sawmill.
6. When raising the turner lever, the side supports rise first. After reaching a fully vertical position, the turner arm will engage and start to rise.
7. Manually lower the log loader so the legs rest on the ground.



CAUTION! Be careful when lowering the log loader. Do not drop the loader onto the ground or perform any action which might break the velocity fuse valves on the loader cylinders. These valves control hydraulic flow and are necessary to prevent the loading arm from collapsing during use.

8. Lower the loader lever to lower the loading arm as far as it will go. Logs must be rolled onto the loading arm one at a time for loading onto the bed of the mill.
9. The front and rear toe boards should be below bed level. Once a tapered log has been loaded, the front or rear end of the log may be lifted to parallel the heart of the log to the path of the blade.

Revisions E7+

The front toe board is raised by lifting the front toe board lever up. The rear toe board is raised by lifting the rear toe board lever up. Once a flat has been made and the log is ready to be turned, push the appropriate toe board lever down to lower either toe board until it falls below the level of the bed.

Revisions C7 - E6

The front toe board is raised by lifting the toe board lever up. The rear toe board is raised by pushing the lever down. Once a flat has been made and the log is ready to be turned, the toe board release valve should be turned clockwise to lower either toe board until it falls below the level of the bed.



CAUTION! Always be sure the toe boards are lowered below bed level before turning or loading logs onto the bed. Loading and turning logs or cants can cause permanent damage to the toe boards if they are left in the up position.

2.9 Loading, Turning, And Clamping Logs



CAUTION! Be sure the pivot end rails (if applicable), turning arm, clamp, and toe boards are out of the way before loading a log onto the bed. Be sure logs are positioned on the bed so that they will not damage the manual winch when loaded. Also, be sure the cutting head is moved far enough forward so the log does not hit it.

To Load Logs

1. Move a log up to the loading arm. Use the manual winch, cant hooks, or loading equipment to move the logs to the foot of the loading arms.
2. Roll the log onto the loader so that it is approximately centered with the sawmill bed. The log turner will operate much easier if the log is centered on the sawmill bed.
3. Raise the loader lever to raise the log onto the sawmill bed. Simply let the loader rise until the log rolls onto the mill bed.
4. Lower the loading arm. Leave the loading arm about halfway up while squaring the log. This will stop the log from rolling off the side of the mill.

NOTE: Logs also may be loaded onto the mill with a tractor or other equipment specifically designed for that purpose.

5. Flip the clamp into the up position by lowering the clamp lever until the clamp contacts the flip arm.

To Turn Logs

1. Raise the turner lever to engage the log turner arm. Let the arm rise until it touches the log and starts to turn it.
2. Spin the log against the side supports until it is turned the way you want it for the first cut. If you want to turn the log more, do the following steps.
3. Engage the clamp by raising the clamp lever.
4. Clamp the log against the side supports.
5. Lower the turner lever to lower the turner arm below the log.
6. Raise the turner arm to get a new bite on the log.
7. Disengage the clamp.
8. The log can be turned now. Repeat steps 4 through 7 until the log is turned as desired.

To Clamp Logs

See Figure 2-10.

1. Raise the clamp lever and clamp the log against the side supports.
2. Lower the turner lever until the turner arm falls below the bed.
3. When the turner arm is lowered all the way, the side supports will begin to lower. Back the clamp off slightly, and let the side supports come down until they are positioned below the level of your first few cuts.

To Level A Tapered Log

Use the toe board lever(s) to raise either end of a tapered log, if desired.

Revisions E7+

Raise the appropriate lever to raise the front or rear toe board until the heart of the log measures the same distance from the bed rails at each end of the log.

Revisions C7 - E6

Raise the lever to raise the front toe board or lower the lever to raise the rear toe board until the heart of the log measures the same distance from the bed rails at each end of the log.

2.10 Clamp Extension

The clamp extension stored in the battery box or at the end of the clamp tube can be used for clamping small cants or logs. The clamp extension is used with the hydraulic clamp in its down position.

Clamp extensions made after 6/92 include a retaining pin which allows the clamp to be stored on the clamp tube end plate.

See Figure 2-11. Remove the retaining pin and clamp extension from its storage position at the end of the clamp assembly. Replace the pin in the storage hole.

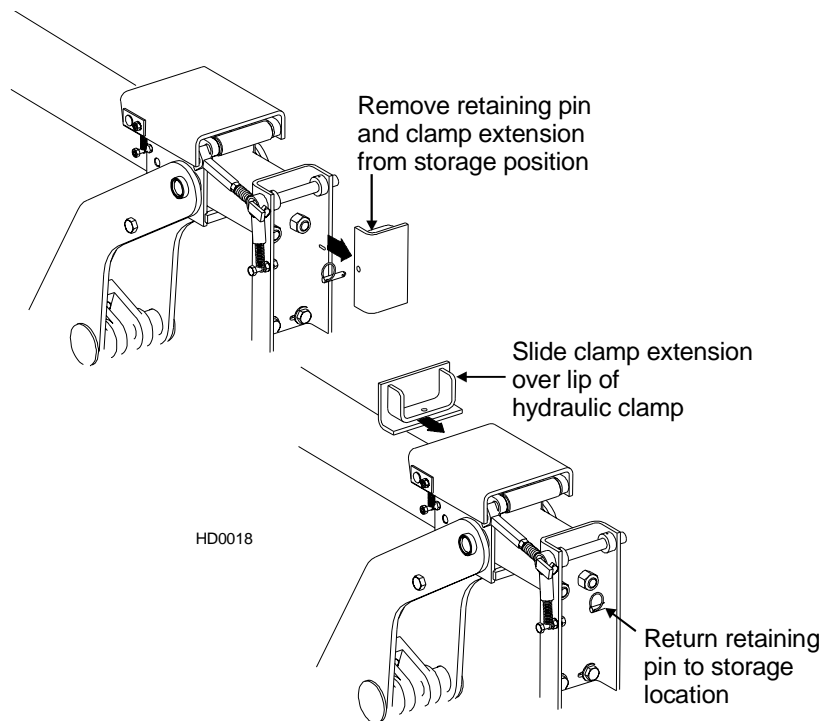

FIG. 2-11

The clamp should be removed from the clamp and returned to its storage position before towing the mill.

2.11 Up/Down Operation

1. Install a blade, if needed, and check for correct blade tension. [See Section 2.5.](#)
2. Set the cutting head to the desired height. (The blade height sight gauge and scale show the height of the blade above the bed rails.)

See Figure 2-12. The up/down switch is located on the far right side of the control panel. Push the switch up to raise the cutting head; push the switch down to lower the cutting head. Hold the switch in position until the cutting head reaches the desired height, then release.

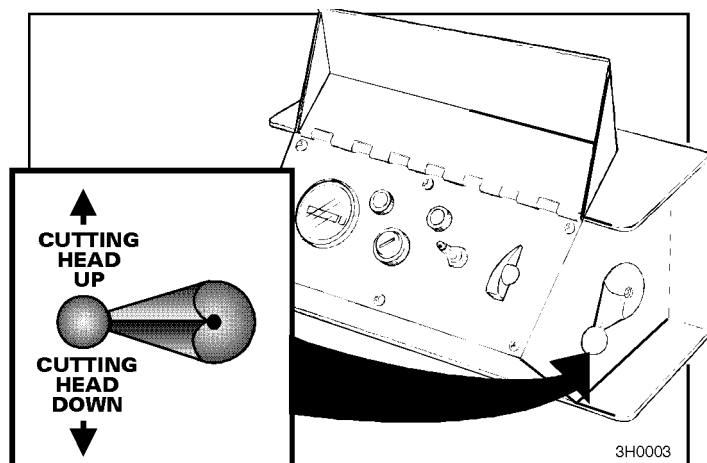

FIG. 2-12

The up/down switch is designed to return to the neutral or "off" position when released. If the switch remains engaged, manually move the switch to the neutral or "off" position. Repair the up/down drum switch. [See Section 4.2.](#)



WARNING! Failure to move the up/down switch to the neutral or "off" position when released will result in failure to stop saw head movement.



CAUTION! DO NOT try to force the carriage above the 35" (88 cm) mark or below the 1" (2.54 cm) mark. Damage to the chain may result.

2.12 Blade Guide Arm Operation

1. Look down the length of the log to see its maximum width. The outer blade guide should be adjusted to clear the widest section of the log by less than 1" (25.4 mm).
2. Use the blade guide toggle switch on the control panel to adjust the outer blade guide as necessary. Push the switch to the left to move the arm in. Push the switch to the right to move the arm out.

See Figure 2-13.

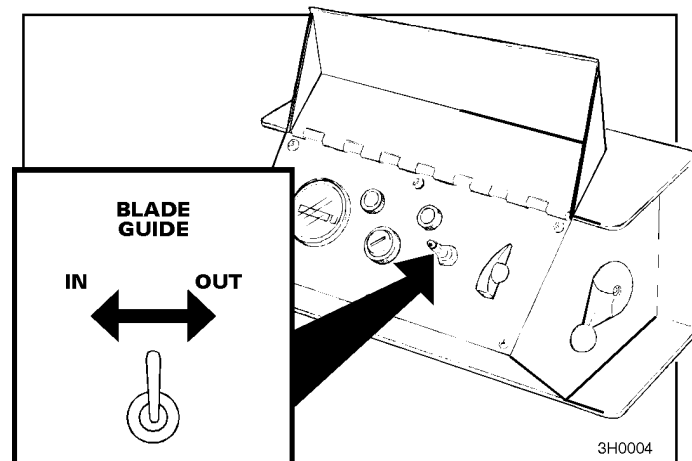

FIG. 2-13

3. Use the blade guide toggle switch to readjust the outer blade guide as you are cutting in order to keep the guide within 1" (2.5 cm) of the log. Be sure to adjust the arm back out before returning the carriage.

2.13 Clutch/Brake Operation

1. Clear any loose objects from the area of the blade, motor, and drive belt.
2. Make sure the clamp and side supports are adjusted below the level of your first few cuts.
3. Start the engine or motor as instructed in the engine manual.



DANGER! Never operate the sawmill without all guards and covers in place and secured.

Be sure the blade housing and pulley covers are in place and secure. If applicable, use the safety retainer pin and cable to fasten blade housing covers.

See Figure 2-14. The clutch/brake lever is located next to the engine.

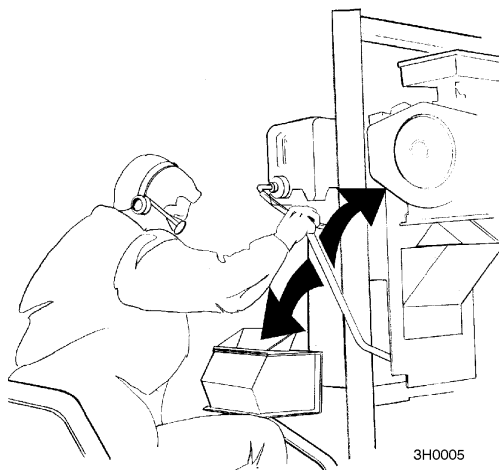

FIG. 2-14

4. To engage the blade, pull the lever down until it locks in the down position. This engages the drive mechanism, releases the blade brake, and increases the engine speed to full throttle.

To disengage the blade, raise the clutch/brake lever to the up position. This disengages the drive belt, engages the blade brake, and returns the engine to idle.



CAUTION! Failing to stop the blade can cause it to be pulled off by a wood sliver (while traveling in reverse). This will ruin the blade. Stopping the blade when returning the carriage also increases the life of the blade.

2.14 Power Feed Operation

See Figure 2-15. The power feed system moves the carriage forward and backward by using two switches on the control panel.

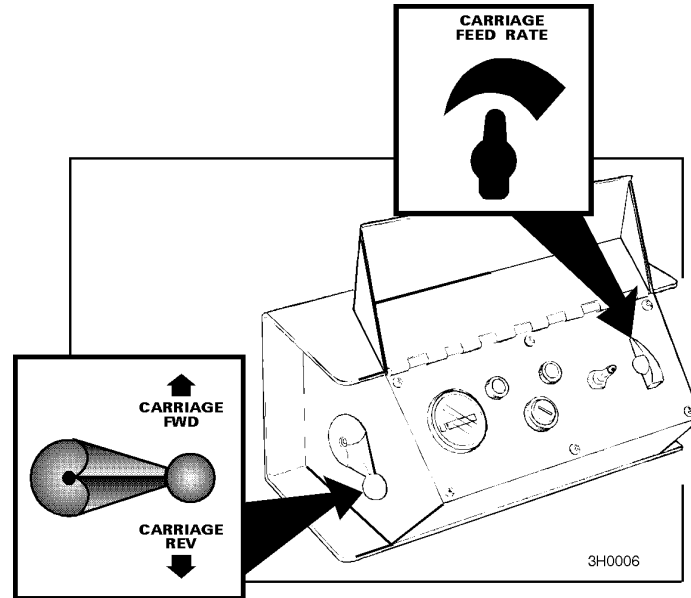

FIG. 2-15

Carriage Feed Rate

The carriage feed rate switch controls the speed at which the carriage travels forward. Turn the switch clockwise to increase speed. Turn it counterclockwise to reduce speed.

Carriage Forward and Reverse

The carriage fwd/rev (forward/reverse) switch controls the direction in which the carriage travels. Turn the fwd/rev switch upward to the CARRIAGE FWD position to move the carriage forward. Turn the switch down to the CARRIAGE REV position to move the carriage backward.

The middle position (as shown) is the neutral position. The power feed switch is designed to return to the neutral or "off" position when released from operating in the reverse position. If the switch remains engaged, manually move the switch to the neutral or "off" position. Repair up/down drum switch. [See Section 4.2.](#)

⚠ DANGER! Failure to move the up/down switch to the neutral or "off" position when released will result in failure to stop saw head carriage movement.

DANGER! Make sure the carriage fwd/rev switch is in the neutral position before turning the key switch to the on or ACC position. This prevents unintended carriage movement.

Using The Power Feed

HINT: To get a straight cut in the first part of the board, feed the blade into the log at a slow speed. This stops the blade from flexing and dipping up or down. Turn the carriage feed rate switch to a slow speed until the whole width of the blade has entered the cut. Then use the carriage feed rate switch to increase the feed rate as desired. Maximum feed rate varies with width and hardness of the wood. Over-feeding results in engine and blade wear, and also produces a wavy cut.

1. Stop the carriage at the end of the cut by turning the carriage feed rate switch counter-clockwise until the carriage stops moving.
2. Throw the clutch/brake lever UP to stop the blade and drop the engine to idle. Remove the board from the top of the log.



CAUTION! Be sure to stop the blade when returning the carriage. This will not only prevent the blade from being pulled off and ruined by a wood sliver, but also will increase the life of the blade.

3. Return the carriage to the front of the mill by turning the carriage fwd/rev switch DOWN. The power feed motor will bypass the carriage feed rate switch and the carriage will automatically return at the fastest speed available. **Always disengage the blade before returning the carriage for the next cut.**
4. Make sure that the blade does not catch on the end of the log. Raise the carriage slightly to make sure the blade clears the log when returned. **HINT:** Try to stop the blade while the heel of the blade is still on the log. Then bring the carriage back without adjusting the blade up. This lets you keep the blade at the current height setting so you can make the next blade height adjustment more quickly.



DANGER! Always keep away from the trailer axle to avoid being caught between the axle and moving saw carriage.

2.15 Cutting The Log

The following steps guide you through normal operation of the Wood-Mizer sawmill.

1. Once the log is placed where you want it and clamped firmly turn the key switch to the ACC position.
2. Determine where to make your first cut. The sight gauge and the blade height scale will help you to do this ([See Section 2.17](#) and [See Section 2.18](#)). Set the blade to the desired height with the up/down switch. Make sure that the blade will clear all side supports and the clamp. Adjust the outer blade guide to clear the widest section of the log by moving the blade guide toggle switch.
3. Make sure all covers and guards are in place. Start the engine. Engage the clutch/brake lever to start the blade spinning.
4. Start the water lube if necessary to prevent sap buildup on the blade. [See Section 2.19](#).
5. Feed the blade into the log slowly ([See Section 2.14](#)). Once the blade completely enters the log, increase the feed rate as desired. Always try to cut at the fastest speed you can while keeping an accurate cut. Cutting too slowly will waste blade life and lower production!
6. As you get to the end of the log, slow down the feed rate. When the teeth exit the end of the log, turn the feed rate all the way down and disengage the clutch/brake lever. Remove the slab that you have just cut from the log.
7. Use the carriage fwd/rev switch to return the carriage to the front of the mill. Always disengage the blade before returning the carriage for the next cut.
8. Repeat until the first side of the log is cut as desired. Set aside the usable flitches (boards with bark on one or both sides). You can edge them on the mill later.
9. Lower the toe boards, if they were used. Use the hydraulic levers to release the clamp and engage the log turner. Turn the log 90 or 180 degrees. Make sure the flat on the log is placed flat against side supports if turned 90 degrees. Make sure it is placed on bed rails if turned 180 degrees. If the log was turned 90 degrees and you are using toe boards to compensate for taper in the log, raise the front or rear toe board again on the second side of the log until the heart is parallel with the bed.
10. Repeat the steps used to cut the first side of the log until the log is square. Cut boards from the remaining cant by adjusting the blade height for the thickness of boards that you want.

Example: Remember that the blade cuts a 1/16 - 1/8" (1.6-3.2 mm) wide kerf. If you want 1" (25.4 mm) thick boards, lower the carriage 1 1/16 - 1 1/8" (27-28.6 mm) for each board.

2.16 Edging

The following steps guide you through edging boards on the Wood-Mizer sawmill.

1. Raise the side supports to 1/2 the height of the flitches, or the boards that need to be edged.
2. Stack the flitches on edge against the side supports.
3. Clamp the flitches against the side supports halfway up the flitch height. (Wider flitches should be placed to the clamp side. When they are edged, flip them over to edge the second side without disturbing the other flitches or without having to pull them from the middle of the stack).
4. Adjust the blade height to edge a few of the widest boards.
5. Loosen the clamp and turn the edged boards over to edge the other side.
6. Repeat steps 2-4.
7. Loosen the clamp and remove the boards that have good clean edges on both sides. Clamp the remaining flitches and repeat steps 2-5.

2.17 Blade Height Sight Gauge

See **Figure 2-16**. The sight gauge is provided on the cutting head carriage to help you decide where to make the first cuts on a log.

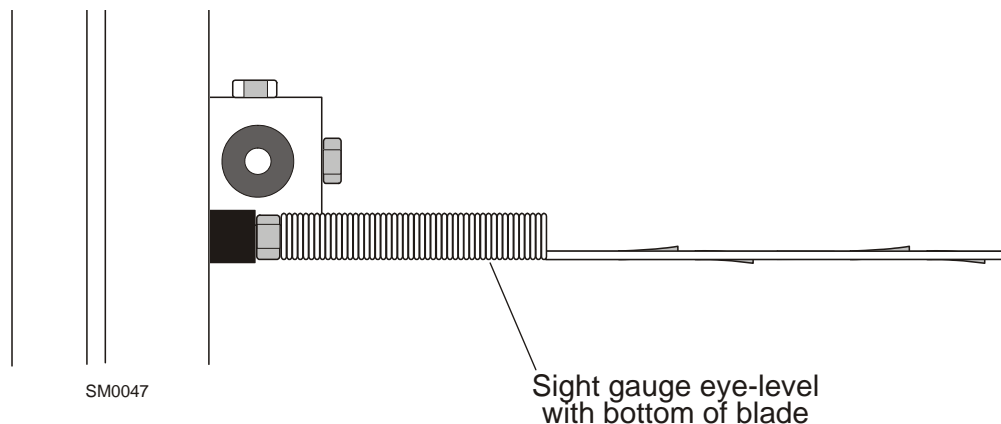

FIG. 2-16

Move the carriage forward until the blade is close to the end of the log.

Position yourself so that your eyes are level with the bottom of the sight gauge spring. With one eye closed, move your head up or down until the bottom of the sight gauge is lined up with the bottom of the blade.

Sight down the length of the log. You should be able to see where the blade will pass through the log down its entire length. Raise or lower the cutting head until you get the blade height you want.

HINT: After judging by eye where you want to make your first slab cut, check the scale. Move the up/down crank to fine-tune the blade height to an even measurement on the blade height scale.

Example: Adjust the blade up to 15" rather than cut at 14 13/16". This will make adjustments for the next cuts easier to figure on the scale.

2.18 Blade Height Scale

See **Figure 2-17**. The blade height scale is attached to the carriage head frame. It includes:

- a blade height indicator
- an inch scale
- a quarter scale

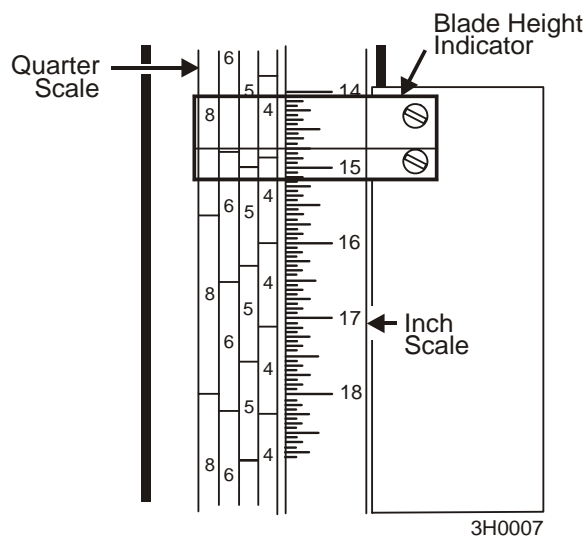

FIG. 2-17

Rev C7-D2: The indicator is attached to the frame and moves up and down with the carriage head. A retrofit is available so that the indicator remains at eye level and the scales move up and down.

Rev D3+: The scales are attached to the frame and move up and down with the carriage head. The blade indicator, used to read the inch and quarter scales, remains stationary.

The Inch Scale

The horizontal red line on the blade height indicator shows how many inches the bottom of the blade is above the bed of the mill. If you know the height of your blade at each cut, you can determine the thickness of lumber you are sawing.

Example: You want to cut 1" (25 mm) random width boards from a log. Use the sight gauge to position the blade for the first cut. Move the carriage to an even measurement on the inch scale. Make a trim cut. Return the carriage for the second cut and lower it 1 1/8" (29 mm) below the original measurement. (The extra 1/8" (3 mm) allows for saw kerf and shrinkage of the lumber.)

Rev. F2+: The scale is shaded. White identifies areas where the blade could encounter a side support or the clamp. Yellow identifies areas where the blade could encounter a side support only.

2 Setup & Operation

Blade Height Scale

The Quarter Scale

See Table 2-2. Two quarter scales are provided with four sets of marks. Each set represents a specific lumber thickness. Saw kerf and shrinkage allowance are included, but actual board thickness will vary slightly depending on blade thickness and tooth set.

To choose which scale to use, determine what finished thickness you want to end up with. The Grade Hardwood Quarter Scale provides thicker finished boards usually required by commercial buyers. The Standard Quarter Scale allows for kerf and shrinkage of finished boards suitable for most custom applications. Always check with your customer before you saw to determine what actual finished thickness is required.

Standard Quarter Scale	
Scale	Actual Board Thickness
4/4	1" (25 mm)
5/4	1 1/4" (32 mm)
6/4	1 5/8" (41 mm)
8/4	2 1/8" (54 mm)

Grade Hardwood Quarter Scale ¹	
Scale	Actual Board Thickness
4/4	1 1/8" (29 mm)
5/4	1 3/8" (35 mm)
6/4	1 5/8" (41 mm)
8/4	2 1/8" (54 mm)

TABLE 2-2

¹ Supplied after 5/95.

To use the quarter scale, look at the blade height indicator. Line up the horizontal red line on the indicator with the nearest mark on the scale you want to use. Make a trim cut. When you return the carriage for a second cut, lower the carriage to the next mark on the scale. This mark shows where the blade should be positioned to cut a certain thickness of lumber, without having to measure on the inch scale.

Example: You want to cut 1" (25 mm) (4/4) random width boards from a log. Use the sight gauge to position the blade for the first cut. Adjust the quarter scale so a 4/4 mark is aligned with the red line on the indicator. Make a trim cut. Return the carriage for the second cut. Now, instead of having to measure down 1 1/8" (29 mm) on the inch scale, you can simply lower the blade so the indicator is aligned with the next 4/4 mark on the quarter scale. Turn the log 90 degrees and repeat.

2.19 Water Lube Operation

See **Figure 2-18**. The Water Lube System keeps the blade clean. Water flows from a 5-gallon (18.9 liter) bottle through a hose to the blade guide where the blade enters the log. A valve in the bottle cap controls the amount of water flow.

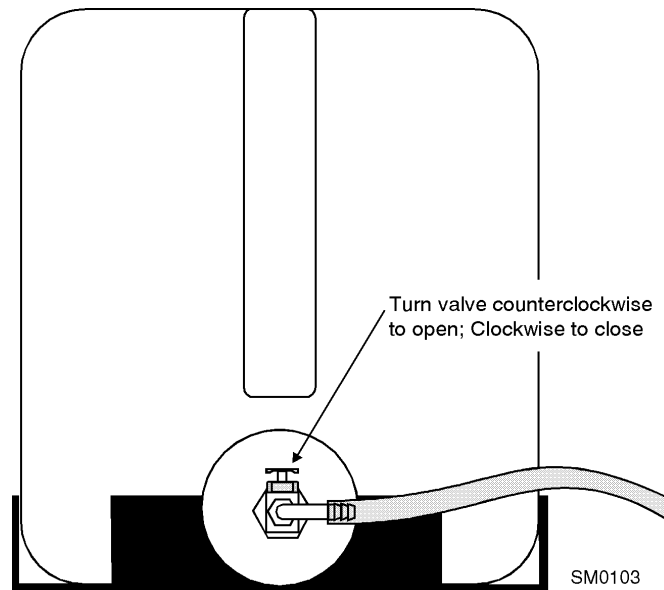

FIG. 2-18

Not all types of wood require the use of the Water Lube System. When it is needed, use just enough water to keep the blade clean. This saves water, and lowers the risk of staining the boards with water. Usual flow will be 1-2 gallons (3.8-7.6 liters) per hour. A squirt of liquid dishwashing detergent in the water bottle will help clean the blade when cutting wood with a high sap content.

WARNING! Never use flammable fuels or liquids instead of water with this accessory. If these type of liquids are necessary to clean the blade, remove it and clean with a rag.

Before removing the blade, engage the clutch/brake lever. Let the blade spin with water running on it for about 15 seconds. This will clean the blade of sap buildup. Wipe the blade dry with a rag before storing or sharpening.

If you are sawing in freezing temperatures, remove the water lube bottle from the sawmill when done sawing and store it in a warm place. Blow any remaining water from the water lube hose.

2.20 Preparing The Sawmill For Towing

The Wood-Mizer trailer package makes transporting your sawmill easy and convenient. To get your sawmill ready for towing, follow these instructions.

1. Move the saw carriage to the front end of the sawmill. Raise the rear outriggers.
2. Use the hydraulic controls to move the log clamp all the way toward the loading side of the mill.



CAUTION! Failure to fully extend the log clamp before towing can result in damage to the clamping assembly during towing.

3. Use the hydraulic controls to raise the log turner and loader as high as they will go. Manually lift the loader and hook the loader chain to the elbow of the turner. Use the hydraulic turner lever to lower the turner until the chain is tight. Push the loader lever down to bring the loader arm channels up to the loader.
4. Move the carriage forward to the travel position over the rear bed rail.
5. Position the holes in the saw head over the travel rest pin.
6. Lower the saw head until it is seated firmly on the rest pin.

See Figure 2-19.

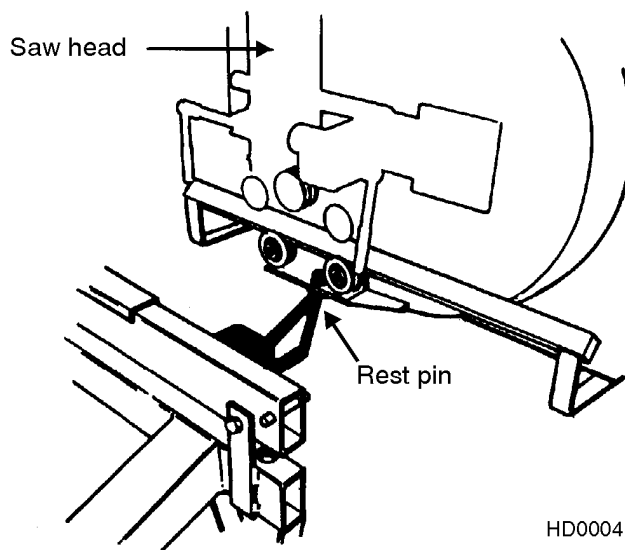

FIG. 2-19

7. Continue lowering the head 3/4" (19mm). until it contacts the stop blocks on the mast rails.



CAUTION! Failure to properly secure the saw head can result in severe machine damage. Lower the saw head onto the rest pin until it contacts the rest pin collar, then lower the saw head 3/4" (19mm) further to insure that the saw head cannot be dislocated from the rest pin.

8. If necessary, adjust the two stops located at the bottom of the mast so the saw head contacts them after it is lowered 3/4" (19mm) past where it contacts the rest pin.

See Figure 2-20.

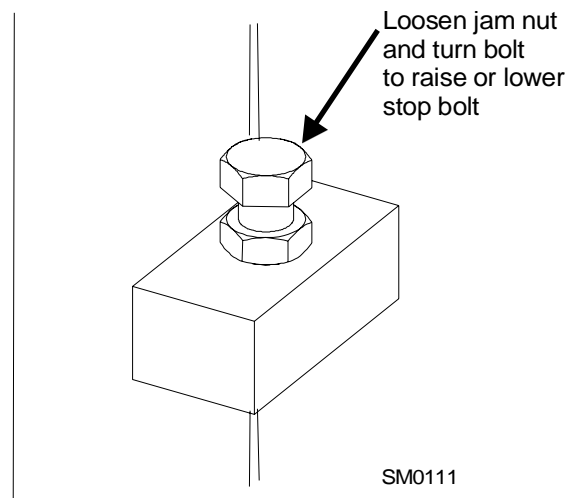

FIG. 2-20

9. Engage the clutch/brake lever. This keeps the drive belt tight and the motor from bouncing while traveling. Be sure to disengage the clutch/brake handle after reaching the destination to avoid deformation of the drive belt.
10. Hook the carriage safety chain located at the bottom of the carriage to the bracket at the bottom of the mast.

See Figure 2-21.

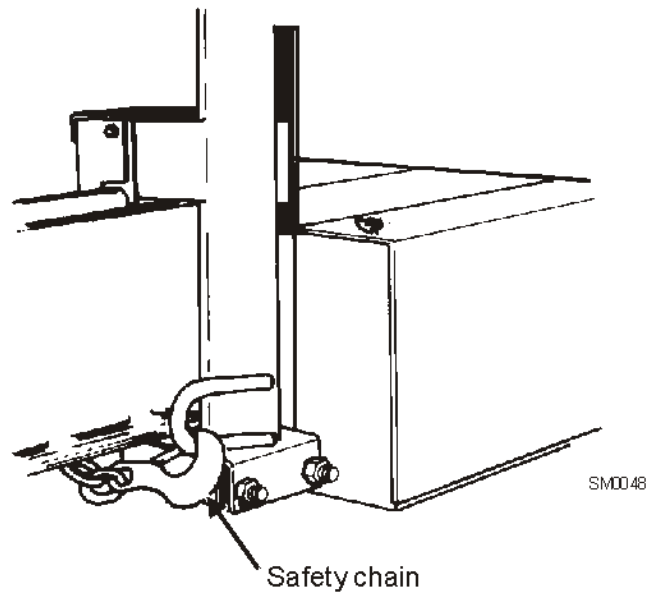

FIG. 2-21

11. Remove all loose objects from the bed of the mill. Store the outrigger jack handle in the bracket provided on the rear/loading-side outrigger guide. Reel in the winch cable. Remove the winch handle.
12. Place both fenders in the slots located behind the trailer tires. Raise all but the very front outrigger.



DANGER! Check to be sure the saw head is resting firmly on the rest pin and mast rail stops and that the safety chain is secured before towing the sawmill.

DANGER! Never operate or tow the sawmill without all guards and covers in place and secured.

Be sure the blade housing and pulley covers are in place and secure. If applicable, use the safety retainer pin and cable to fasten blade housing covers.

See the trailer operator's manual for specific information regarding hitch operation and towing the sawmill.

SECTION 3 MAINTENANCE

This section lists the maintenance procedures that need to be performed.

The Short Interval Maintenance Schedule lists procedures that need to be performed every 4, 8 or 25 hours. The Maintenance Log lists procedures that need to be performed every 50, 100, 200, 300, 500, or 1000 hours. Keep track of machine maintenance by filling in the machine hours and the date you perform each procedure.



This symbol identifies the interval (hours of operation) at which each maintenance procedure should be performed.

3.1 Wear Life

See Table 3-1. This chart lists estimated life expectancy of common replacement parts if proper maintenance and operation procedures are followed. Due to the many variables which exist during sawmill operation, actual part life may vary significantly. This information is provided so that you may plan ahead in ordering replacement parts.

Part Description	Estimated Life
Up/Down Motor Brushes	375 hours
B57 Blade Wheel Belts	400 hours
Up/Down Motor	750 hours
Hydraulic Pump Solenoid	750 hours
Power Feed Motor Brushes	750 hours
Up/Down Drum Switch	1000 hours
Blade Guide Rollers	1000 hours
Hydraulic Pump Motor Brushes	1000 hours
Power Feed Drum Switch	1200 hours
Drive Belt	1250 hours
Power Feed Motor	1500 hours
Power Feed Belt	2000 hours
Up/Down Belt	2000 hours

TABLE 3-1

3.2 Blade Guides

See Figure 3-1.

1. Lubricate the blade guide rollers every four hours of operation. Use one squeeze of a NLGI No. 2 grade lithium grease from a grease gun to lubricate the bearings and remove any sawdust.

4

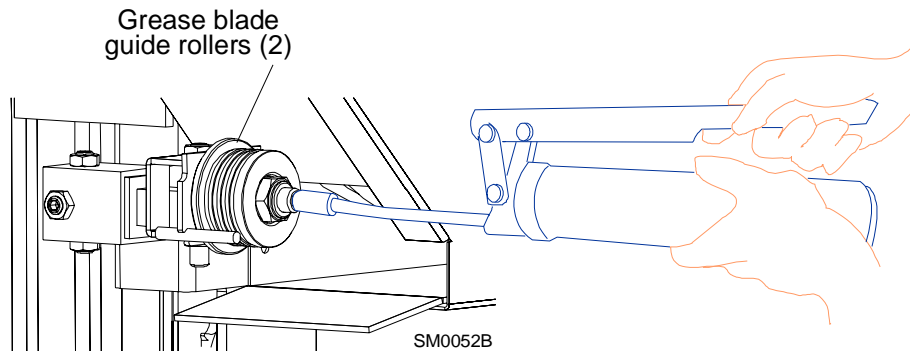

FIG. 3-1



CAUTION! Do not over-grease. Over-greasing will push the seals out of the blade guide bearings.

2. Check the rollers for performance and wear every blade change. Make sure the rollers are clean and spinning freely. If not, rebuild them. Replace any rollers which have worn smooth or have become cone shaped. See The LT30HD/40HD Parts manual for blade guide rebuild kits and complete roller assemblies.
3. The blade guide set screws on sawmills built after 9/93 are stainless steel which prevent corrosion from making the screws difficult to adjust. Screws on older sawmills may be replaced with the stainless steel screw.

3.3 Hydraulic Log Loader



Remove all sawdust and debris from around the velocity fuse valves every 8 hours of operation. The valves are located at the bottom of the log loader cylinders.

3.4 Blade Housing

1. Remove the excess sawdust from the blade wheel housings and sawdust chute every blade change.

See Figure 3-2.

2. Make sure the blade screw (or cam bearing on machines before 11/91) in the top center of the C-frame is $1/16"$ (1.5 mm) below the bottom of the blade. If not, loosen the nut and adjust the screw as necessary. Check the screw every 500 hours of operation. Failing to maintain this adjustment will lead to early blade breakage.

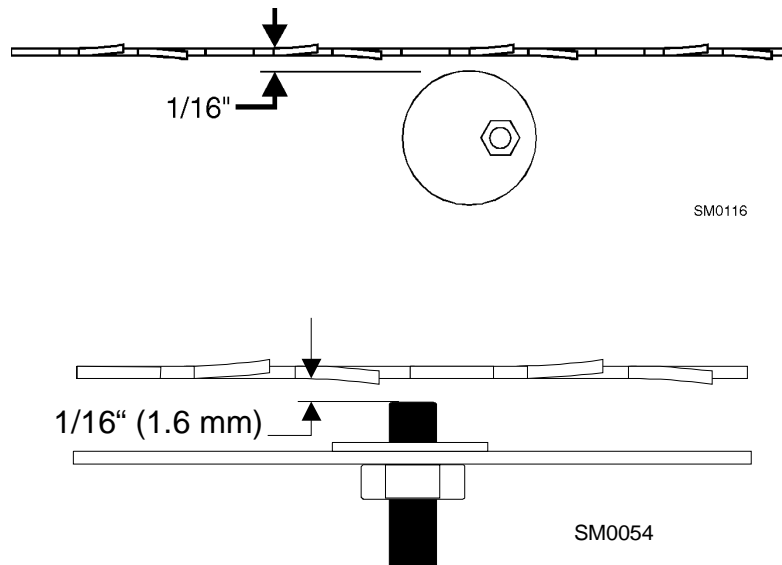

FIG. 3-2

3.5 Carriage Track, Wiper & Scrapers

See Figure 3-3.

1. Clean the upper and lower track rails to remove any sawdust and sap buildup every eight hours of operation. Lubricate the lower track rail by wiping it with Dexron III ATF.

NOTE: If the top rail is not factory painted, apply a rust inhibitor such as Sherwin-Williams P.D.R.P #710 when the sawmill is not in use. Use a clean, dry cloth and a light lubricant such as WD-40 to remove the protection coat before operating the sawmill.

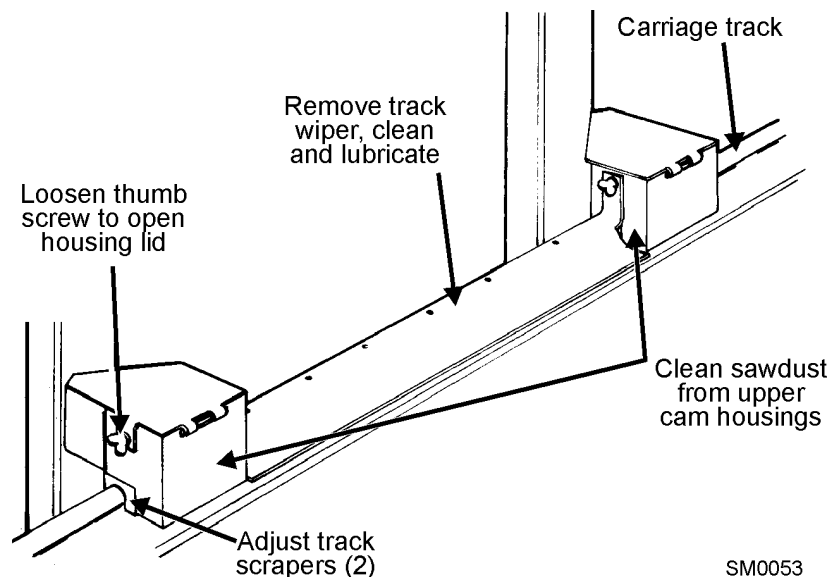

SM0053

FIG. 3-3

2. Remove sawdust from the upper cam housings. Loosen the thumb screws on the upper cam housing covers and open. Brush any sawdust buildup from the housings.
3. Check the track scrapers as needed. Make sure the scrapers fit firmly against the rail. If a track scraper needs to be adjusted, loosen the thumb screw, push the scraper downward until it fits firmly against the rail, and retighten the thumb screw.
4. Clean and lubricate the track wiper every twenty-five hours of operation. Unbolt the wiper, remove it from the sawmill, and remove any sawdust buildup. Soak the felt wiper with Dexron III transmission fluid, 10W30 motor oil or 3-in-1 turbine oil. Replace the wiper.



CAUTION! Reinstall the wiper so that it lightly touches the track rail. If the wiper presses too firmly against the rail, it can cause the power feed to bind.

3.6 Track Rollers

See Figure 3-4.

1. Lubricate the greasable track roller bearings every fifty hours of operation. Use a NLGI No. 2 grade lithium grease.

50

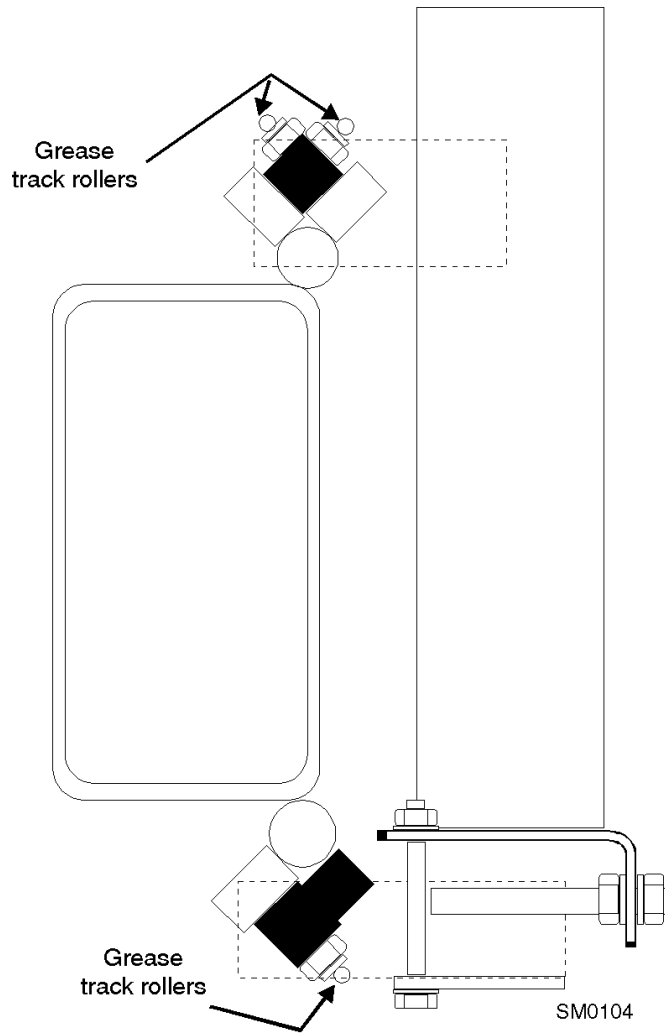

FIG. 3-4

3.7 Vertical Mast Rails

50

Clean and lubricate the vertical mast rails every 50 hours of operation. Clean with solvent and remove any rust with a light-grade sand paper or emery cloth. Lubricate the mast with motor oil or automatic transmission fluid (ATF).



CAUTION! Never use grease on the mast rails as it will collect sawdust.

3.8 Drum Switches





Lubricate the up/down and power feed drum switch contacts inside the control panel every fifty hours of operation. Use only contact grease supplied by Wood-Mizer. Remove the control panel cover. Use a cotton swab to apply grease to the switch contact ends.



WARNING! Drum switch grease contains Petroleum Hydrocarbon Lubricant. Eye and skin irritant. If introduced into eyes, flush with water for at least 15 minutes. If film or irritation persists, seek medical attention. Wash skin with soap and water. If ingested, do not induce vomiting - contact a physician. **KEEP OUT OF THE REACH OF CHILDREN.**

3.9 Miscellaneous Lubrication

1.  Apply a thin film of a NLGI No. 2 grade lithium grease to the blade guide arm every fifty hours of operation to help prevent it from rusting.
2.  Grease the clamp mechanism, loading arm, and side supports with a NLGI No. 2 grade lithium grease every fifty hours of operation.
3.  Oil all chains with Dexron III ATF every fifty hours of operation.



CAUTION! Do not use chain lube. It causes sawdust buildup in chain links.

3.10 Blade Tensioner

1. Lubricate the chrome rods of the tensioner system with a heavy duty teflon spray lubricant, such as Gunk L508, every fifty hours of operation.

50

2. Lubricate the tensioner screw handle with a NLGI No. 2 grade lithium grease as needed.

See Figure 3-5.

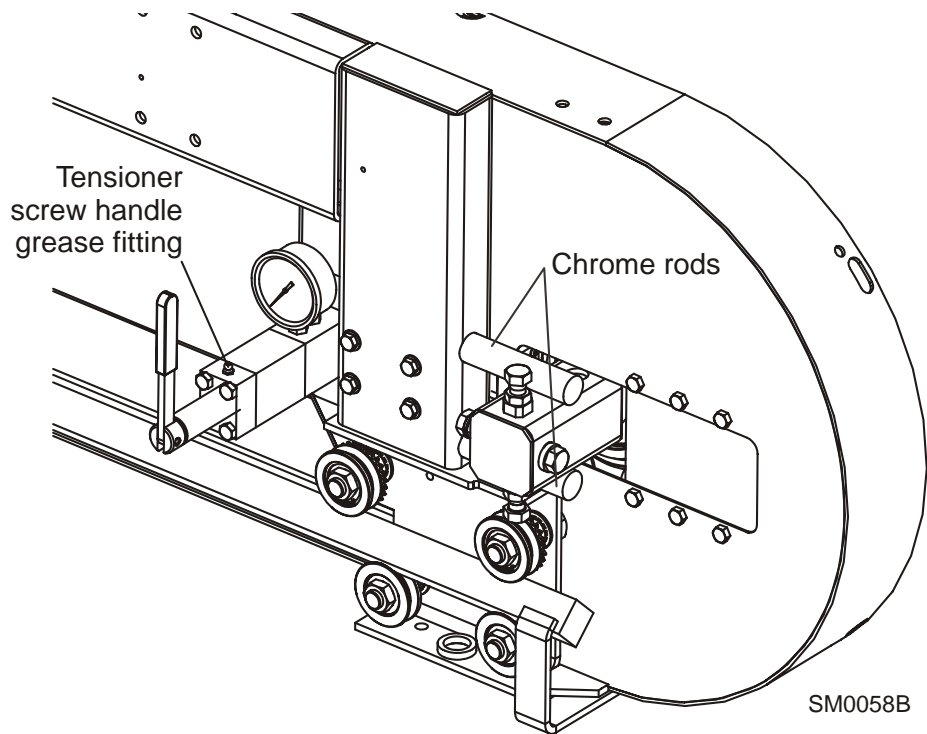



FIG. 3-5

3.11 Blade Wheel Belts

1. Rotate the blade wheel belts and check them for wear. Rotating the belts every 50 hours will give you longer belt life. Replace belts as necessary. Use only B57 belts manufactured by Goodyear or Browning.
 50
2. Periodically check all belts for wear. Replace any damaged or worn belts as needed.

3.12 Brake Strap Adjustment

200

Hydraulic Sawmills Revisions F2+: Check the brake strap for wear every 200 hours of operation. Replace if damaged or worn.

Also check and adjust the brake strap if the blade does not stop quickly, unusual sounds occur when the brake is applied, or a sudden change is noticed in the clutch handle position when the clutch is disengaged. To access the brake strap, remove the belt cover located underneath the engine. Engage the clutch/brake lever. Loosen the two brake strap clamping bolts and slide the lower brake strap clamping plate and metal-backed brake strap forward until snug. Retighten the bolts. Replace the belt cover.

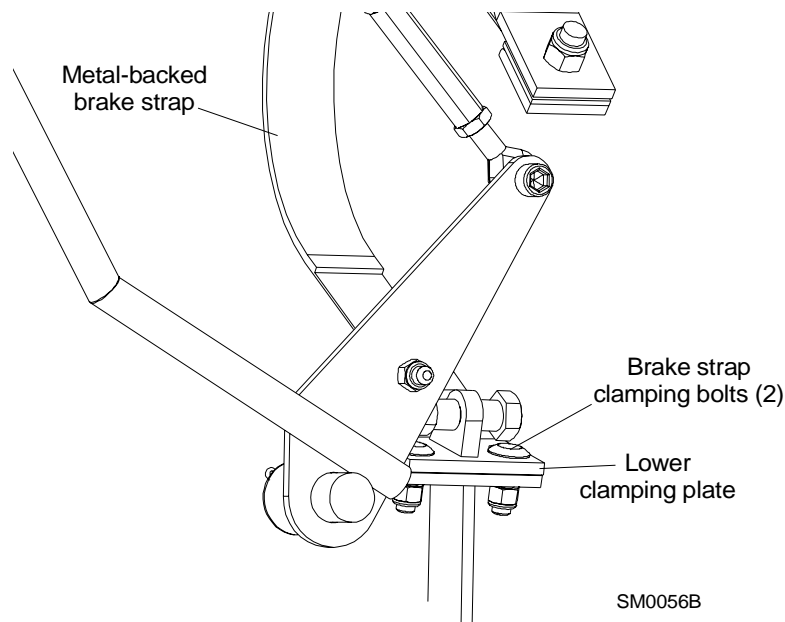

FIG. 3-5

50

Hydraulic Sawmills Revisions F1 and Prior: Check the brake strap after the first 20 hours, and every 50 hours thereafter. If the blade does not stop quickly, the brake strap needs adjusting. To access the brake strap, remove the two belt covers located underneath the engine. Engage the clutch/brake lever. Loosen the two brake strap clamping bolts and pull the brake strap about 1/2" (12.7 mm) through the clamping plates. Retighten the bolts. Replace the belt guards.

See Figure 3-6.

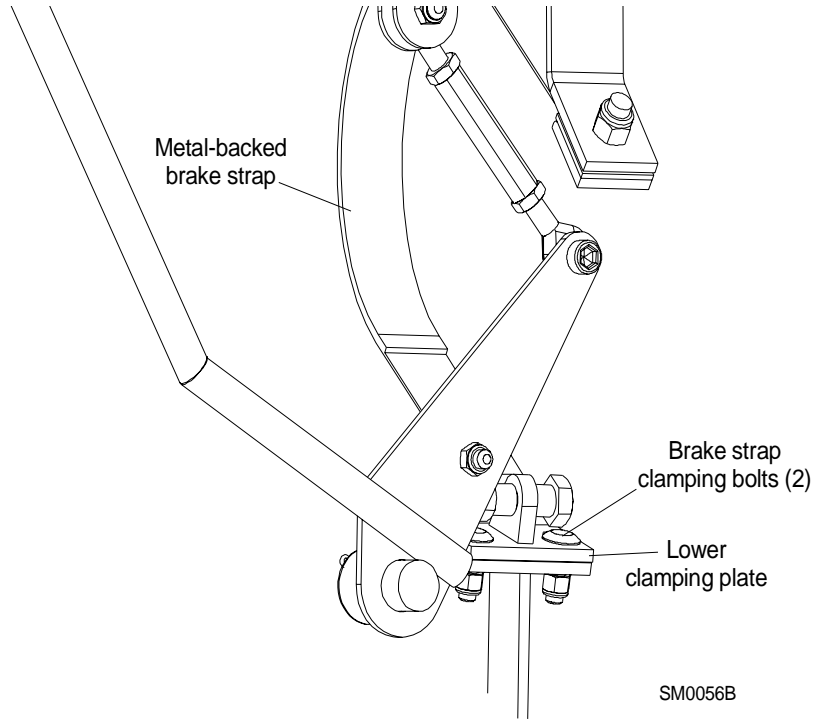

FIG. 3-6

3.13 Hydraulic System

1. Check the hydraulic fluid level every fifty hours of operation. Add fluid as necessary. The level in the hydraulic pump should be 4 1/2" (114 mm) with all cylinders collapsed.

If humidity is a problem or the mill is used outside in humid weather, drain and replace two quarts (.95 liters) of fluid every six months. This will drain any accumulated water and help prevent pump failure due to water ingestion. It also will prevent excessive fluid wear and allow the fluid to maintain its hot end performance.

If humidity is not a problem, drain and replace one gallon (3.8 liters) of fluid every year to prevent fluid wear.

See Figure 3-7. If you are operating in temperatures -20° to 100° F (-29° to 38° C), use an all-weather hydraulic fluid such as Exxon Unavis HVI 26 (formerly named J26). For alternate fluids and/or other temperature ranges, refer to the chart below. Operating above the recommended temperature range of a fluid could result in excessive pump wear. Operating below the recommended temperature range could result in reduced hydraulic cylinder speed. To change fluid types, replace one gallon of the current fluid with one gallon of the alternate fluid.

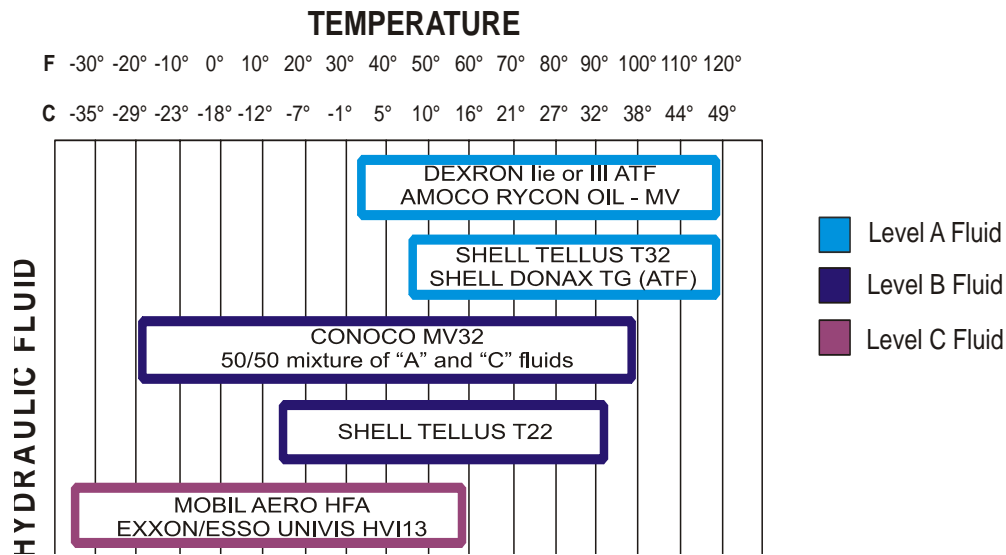

FIG. 3-7

2. Hydraulic Sawmills Revisions E7+ Only: Replace the hydraulic system cartridge filter every 500 hours of operation.

3. Hydraulic Sawmills purchased before 12/93 Only: Service the hydraulic drive motor (D.C. Motor) every 500 hours of operation. Refer to the Electrical Problems section of the Monarch manual, page 7, section 2, steps A-H. Also make sure the slots between the commutator segments are clear of foreign material.

To check for excessive end play, as listed in step H, perform the following:

- Remove the rear head assembly.
 - Position (push) the armature shaft to assure that its drive tab is fully engaged with the pump shaft slot.
 - Position (push) the stator frame so it is tight against the pump.
 - Lay a 6" (15 cm) straightedge across the shaft's exposed bearing journal so it is in contact with the end of the stator's outer wrap.
 - Measure the gap between the straightedge and the fiber thrust washers located against the end of the commutator.
 - Add fiber washers as needed to give a .02 to .05 inch (.51 to 1.27 mm) gap.
 - Make sure the washer which contacts the end of the commutator is made of steel.
 - Assemble the rear head assembly to the motor.
4. Periodically check all hydraulic lines and fitting as needed. Replace as necessary.

3.14 Drive Bearing

1000 Refill the fluid in the drive-side cylinder bearing housing every 1000 hours of operation. Remove the top and bottom oil plugs. Pour an Automatic Transmission Fluid (ATF) such as Dexron III ATF into the top hole until it begins to flow from the bottom hole. Reinstall the square oil plug to the bottom hole and the vented oil plug to the top hole.

See Figure 3-8.

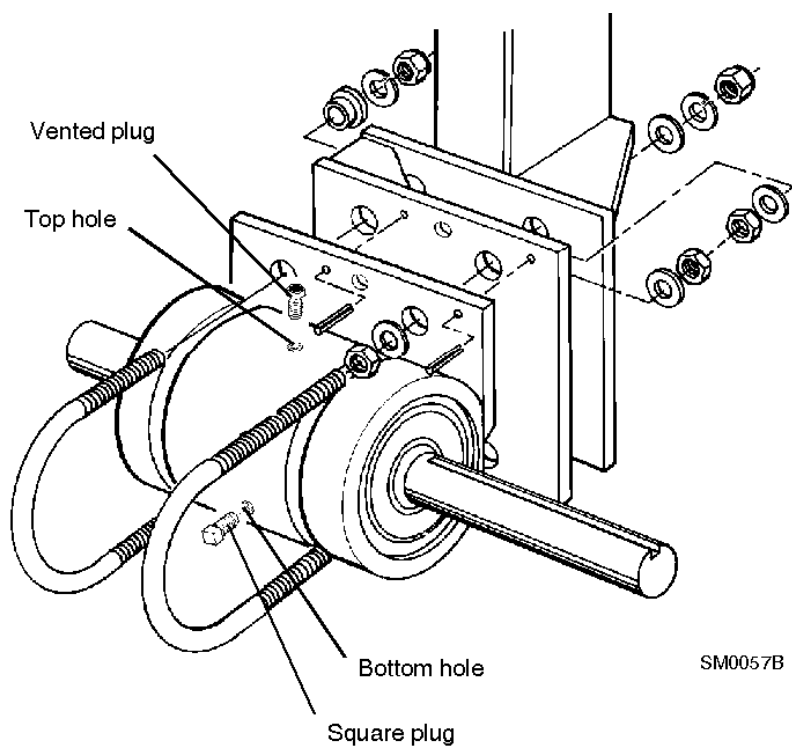

FIG. 3-8

3.15 Up/Down System

1. Grease the up/down gear reducer shaft bearing with a NLGI No. 2 grade lithium grease every 1000 hours of operation.

See Figure 3-9.

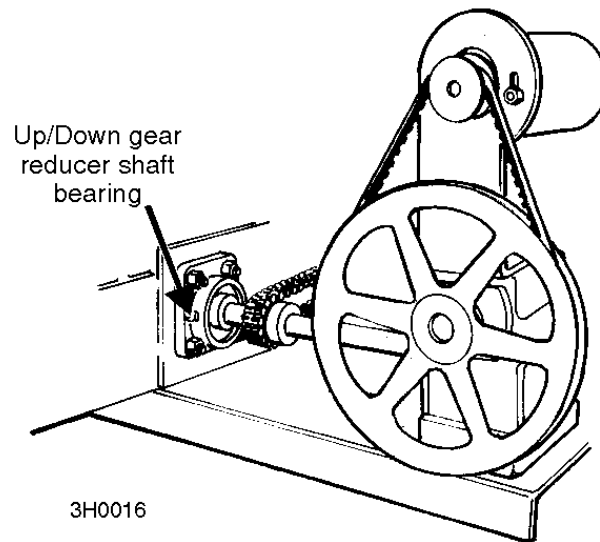

FIG. 3-9

3**Maintenance***Up/Down System*

2. Adjust the up/down belt as needed. Remove the up/down housing cover. To tighten the belt, loosen the two motor mount nuts. Adjust the bolt underneath the motor upward so there is 3/8" (9.5 mm) deflection with a 7 lb. (3.2 Kg) deflection force. Tighten the jam nut to secure the bolt in place. Retighten the motor mount nuts. Replace the drive pulley cover.

See Figure 3-10.

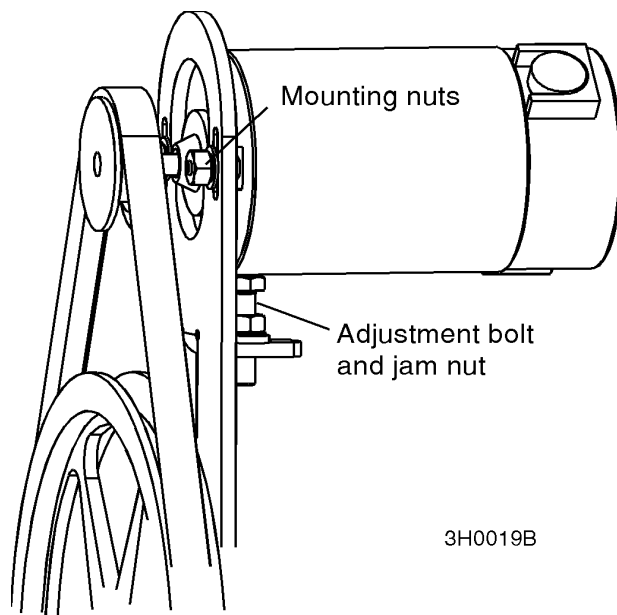



FIG. 3-10

- Adjust the up/down chain tension as needed. Measure chain tension with the head all the way to the top of the vertical mast. Secure the carriage with a chain at the top. Find the chain adjusting bolt at the bottom of the mast, behind the battery box. Adjust the nuts on the bolt until you can get about 1 1/2" (3.8 cm) total deflection in the center of the chain with a 5 lb. (2.3 Kg) deflection force.

See Figure 3-11.

 **DANGER!** Always secure the cutting head with a 5/16" chain with at least 1900 lbs. working load capacity before adjusting the up/down chain. The cutting head may fall, causing severe injury or death.

 **CAUTION!** Do not over-tension the chain. Over-tensioning the chain may lead to early failure of the gear reducer.

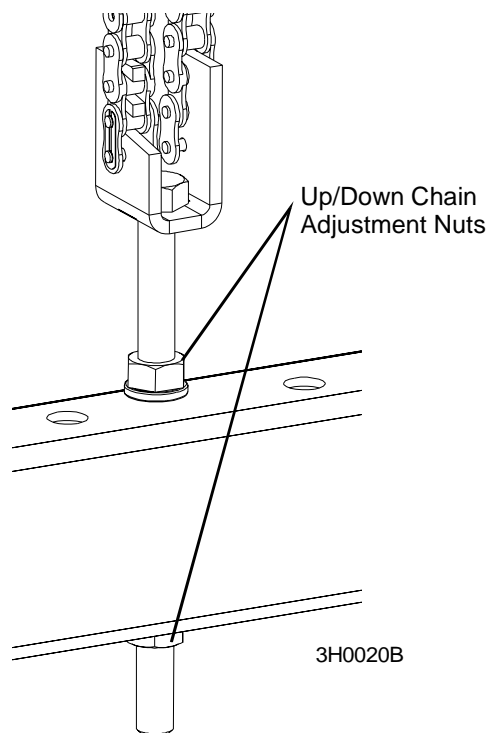

FIG. 3-11

- Check the up/down gearbox oil level. Add a synthetic gear oil such as Mobil SHC 634 as needed. Drain and refill the gearbox with 8 - 11 ounces of oil after the first 250 hours of sawmill operation. Repeat every 5000 hours or every 2 years, whichever comes first.

Wood-Mizer offers replacement gear oil in 8 ounce bottles.

3.16 Power Feed

1. Adjust the power feed belt as needed. When the power feed belt gets loose, it will begin slipping. This causes the carriage to not move forward when cutting. To retighten the belt, remove the feed motor cover. Loosen the three motor mounting bolts.

See Figure 3-12. Pivot the motor so that the motor pulley moves away from the large feed pulley. Tighten the belt so there is 1/8" (3 mm) deflection with a 7 lb. (3.2 Kg) deflection force. Retighten the motor bolts and replace the feed motor cover.

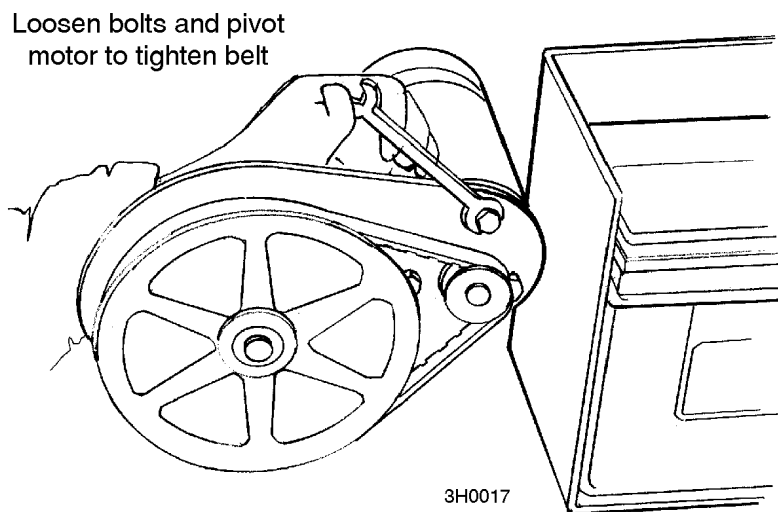

FIG. 3-12

2. Adjust the power feed chain as needed. Measure the power feed chain tension with the saw head all the way toward the front of the mill. Use the two lock nuts at the rear of the mill to tighten or loosen the power feed chain. Adjust the chain until it measures 7 to 8 inches (17.8 to 20.3 cm) from the top of the top rail at its lowest point.



CAUTION! Do not overtighten the feed chain. Damage to the power feed motor may result.

See Figure 3-13.

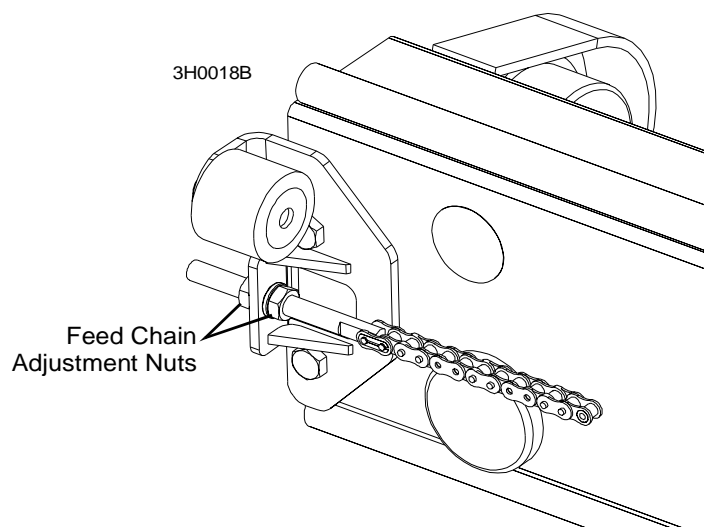

FIG. 3-13

3.17 Miscellaneous Maintenance

1. Check the mill alignment every setup. [See Section 5. Alignment.](#)
2. Make sure all safety warning decals are readable. Remove sawdust and dirt. Replace any damaged or unreadable decals immediately. Order decals from your Customer Service Representative.



WARNING! Keep all safety warning decals clean and visible. If decal becomes worn or damaged, replace immediately.

3. Check all battery and fuse box connections are tight and free of corrosion. In 7/93, the fuse block assembly was upgraded to prevent connections from coming loose and overheating. The fuse block can be retrofitted to LT30HD/40HD rev D3-E2.

LT30HD/40HD Short Interval Maintenance Schedule

PROCEDURE	MANUAL REFERENCE
EVERY 4 HOURS	
Lubricate Blade Guide Rollers	SEE SECTION 3.2
EVERY BLADE CHANGE	
Check Blade Guide Roller Performance	SEE SECTION 3.2
Remove Excess Sawdust From Blade Wheel Housings And Sawdust Chute	SEE SECTION 3.4
EVERY 8 HOURS	
Clean And Lubricate Track	SEE SECTION 3.5
Remove Sawdust From Upper Cam Housings	SEE SECTION 3.5
Clean Sawdust From Hydraulic Loader Velocity Fuse Valves	SEE SECTION 3.3
EVERY 25 HOURS	
Clean And Lubricate Upper Track Wiper	SEE SECTION 3.5

WOOD-MIZER LT30HD/LT40HD MAINTENANCE LOG

PROCEDURE	MANUAL REFERENCE	TOTAL HOURS OF OPERATION									
		FILL IN THE DATE AND THE MACHINE HOURS AS YOU PERFORM EACH PROCEDURE. A SHADED BOX INDICATES MAINTENANCE IS NOT NEEDED AT THIS TIME.									
		50 HRS	100 HRS	150 HRS	200 HRS	250 HRS	300 HRS	350 HRS	400 HRS	450 HRS	500 HRS
Clean & lube mast rails	See Section 3.7										
Grease track rollers (If greasable rollers)	See Section 3.6										
Lubricate drum switches	See Section 3.8										
Grease pivot points and bearings/Oil chains	See Section 3.9 See Section 3.15 See Section 3.16										
Check belt tensions	See Section 3.15 See Section 3.16										
Check brake strap tension	See Section 3.12										
Rotate drive/idle blade wheel belts/Check all belts for wear	See Section 3.11										
Check feed & up/down chain tensions	See Section 3.15 See Section 3.16										
Check up/down gear box fluid level	See Section 3.15										
Lubricate blade tensioner handle and rods	See Section 3.10										
Inspect hydraulic lines & fittings	See Section 3.13										
Check hydraulic fluid level	See Section 3.13										
Check blade screw (or cam bearing)	See Section 3.4										
Replace hydraulic system filter (Rev E7+)	See Section 3.13										
Service Hydraulic Drive Motor (Rev C7 - E6)	See Section 3.13										
Replace cylinder drive bearing fluid	See Section 3.14										
Grease up/down shaft bearing	See Section 3.15										

WOOD-MIZER LT30HD/LT40HD MAINTENANCE LOG

PROCEDURE	MANUAL REFERENCE	TOTAL HOURS OF OPERATION									
		FILL IN THE DATE AND THE MACHINE HOURS AS YOU PERFORM EACH PROCEDURE. A SHADED BOX INDICATES MAINTENANCE IS NOT NEEDED AT THIS TIME.									
		550 HRS	600 HRS	650 HRS	700 HRS	750 HRS	800 HRS	850 HRS	900 HRS	950 HRS	1000 HRS
Clean & lube mast rails	See Section 3.7										
Grease track rollers (If greasable rollers)	See Section 3.6										
Lubricate drum switches	See Section 3.8										
Grease pivot points and bearings/Oil chains	See Section 3.9 See Section 3.15 See Section 3.16										
Check belt tensions	See Section 3.15 See Section 3.16										
Check brake strap tension	See Section 3.12										
Rotate drive/idle blade wheel belts/Check all belts for wear	See Section 3.11										
Check feed & up/down chain tensions	See Section 3.15 See Section 3.16										
Check up/down gear box fluid level	See Section 3.15										
Lubricate blade tensioner handle and rods	See Section 3.10										
Inspect hydraulic lines & fittings	See Section 3.13										
Check hydraulic fluid level	See Section 3.13										
Check blade screw (or cam bearing)	See Section 3.4										
Replace hydraulic system filter (Rev E7+)	See Section 3.13										
Service Hydraulic Drive Motor (Rev C7 - E6)	See Section 3.13										
Replace cylinder drive bearing fluid	See Section 3.14										
Grease up/down shaft bearing	See Section 3.15										

WOOD-MIZER LT30HD/LT40HD MAINTENANCE LOG

PROCEDURE	MANUAL REFERENCE	TOTAL HOURS OF OPERATION									
		FILL IN THE DATE AND THE MACHINE HOURS AS YOU PERFORM EACH PROCEDURE. A SHADED BOX INDICATES MAINTENANCE IS NOT NEEDED AT THIS TIME.									
		1050 HRS	1100 HRS	1150 HRS	1200 HRS	1250 HRS	1300 HRS	1350 HRS	1400 HRS	1450 HRS	1500 HRS
Clean & lube mast rails	See Section 3.7										
Grease track rollers (If greasable rollers)	See Section 3.6										
Lubricate drum switches	See Section 3.8										
Grease pivot points and bearings/Oil chains	See Section 3.9 See Section 3.15 See Section 3.16										
Check belt tensions	See Section 3.15 See Section 3.16										
Check brake strap tension	See Section 3.12										
Rotate drive/idle blade wheel belts/Check all belts for wear	See Section 3.11										
Check feed & up/down chain tensions	See Section 3.15 See Section 3.16										
Check up/down gear box fluid level	See Section 3.15										
Lubricate blade tensioner handle and rods	See Section 3.10										
Inspect hydraulic lines & fittings	See Section 3.13										
Check hydraulic fluid level	See Section 3.13										
Check blade screw (or cam bearing)	See Section 3.4										
Replace hydraulic system filter (Rev E7+)	See Section 3.13										
Service Hydraulic Drive Motor (Rev C7 - E6)	See Section 3.13										
Replace cylinder drive bearing fluid	See Section 3.14										
Grease up/down shaft bearing	See Section 3.15										

WOOD-MIZER LT30HD/LT40HD MAINTENANCE LOG

PROCEDURE	MANUAL REFERENCE	TOTAL HOURS OF OPERATION									
		FILL IN THE DATE AND THE MACHINE HOURS AS YOU PERFORM EACH PROCEDURE. A SHADED BOX INDICATES MAINTENANCE IS NOT NEEDED AT THIS TIME.									
		1550 HRS	1600 HRS	1650 HRS	1700 HRS	1750 HRS	1800 HRS	1850 HRS	1900 HRS	1950 HRS	2000 HRS
Clean & lube mast rails	See Section 3.7										
Grease track rollers (If greasable rollers)	See Section 3.6										
Lubricate drum switches	See Section 3.8										
Grease pivot points and bearings/Oil chains	See Section 3.9 See Section 3.15 See Section 3.16										
Check belt tensions	See Section 3.15 See Section 3.16										
Check brake strap tension	See Section 3.12										
Rotate drive/idle blade wheel belts/Check all belts for wear	See Section 3.11										
Check feed & up/down chain tensions	See Section 3.15 See Section 3.16										
Check up/down gear box fluid level	See Section 3.15										
Lubricate blade tensioner handle and rods	See Section 3.10										
Inspect hydraulic lines & fittings	See Section 3.13										
Check hydraulic fluid level	See Section 3.13										
Check blade screw (or cam bearing)	See Section 3.4										
Replace hydraulic system filter (Rev E7+)	See Section 3.13										
Service Hydraulic Drive Motor (Rev C7 - E6)	See Section 3.13										
Replace cylinder drive bearing fluid	See Section 3.14										
Grease up/down shaft bearing	See Section 3.15										

WOOD-MIZER LT30HD/LT40HD MAINTENANCE LOG

PROCEDURE	MANUAL REFERENCE	TOTAL HOURS OF OPERATION									
		FILL IN THE DATE AND THE MACHINE HOURS AS YOU PERFORM EACH PROCEDURE. A SHADED BOX INDICATES MAINTENANCE IS NOT NEEDED AT THIS TIME.									
		2050 HRS	2100 HRS	2150 HRS	2200 HRS	2250 HRS	2300 HRS	2350 HRS	2400 HRS	2450 HRS	2500 HRS
Clean & lube mast rails	See Section 3.7										
Grease track rollers (If greasable rollers)	See Section 3.6										
Lubricate drum switches	See Section 3.8										
Grease pivot points and bearings/Oil chains	See Section 3.9 See Section 3.15 See Section 3.16										
Check belt tensions	See Section 3.15 See Section 3.16										
Check brake strap tension	See Section 3.12										
Rotate drive/idle blade wheel belts/Check all belts for wear	See Section 3.11										
Check feed & up/down chain tensions	See Section 3.15 See Section 3.16										
Check up/down gear box fluid level	See Section 3.15										
Lubricate blade tensioner handle and rods	See Section 3.10										
Inspect hydraulic lines & fittings	See Section 3.13										
Check hydraulic fluid level	See Section 3.13										
Check blade screw (or cam bearing)	See Section 3.4										
Replace hydraulic system filter (Rev E7+)	See Section 3.13										
Service Hydraulic Drive Motor (Rev C7 - E6)	See Section 3.13										
Replace cylinder drive bearing fluid	See Section 3.14										
Grease up/down shaft bearing	See Section 3.15										

WOOD-MIZER LT30HD/LT40HD MAINTENANCE LOG

PROCEDURE	MANUAL REFERENCE	TOTAL HOURS OF OPERATION									
		FILL IN THE DATE AND THE MACHINE HOURS AS YOU PERFORM EACH PROCEDURE. A SHADED BOX INDICATES MAINTENANCE IS NOT NEEDED AT THIS TIME.									
		2550 HRS	2600 HRS	2650 HRS	2700 HRS	2750 HRS	2800 HRS	2850 HRS	2900 HRS	2950 HRS	3000 HRS
Clean & lube mast rails	See Section 3.7										
Grease track rollers (If greasable rollers)	See Section 3.6										
Lubricate drum switches	See Section 3.8										
Grease pivot points and bearings/Oil chains	See Section 3.9 See Section 3.15 See Section 3.16										
Check belt tensions	See Section 3.15 See Section 3.16										
Check brake strap tension	See Section 3.12										
Rotate drive/idle blade wheel belts/Check all belts for wear	See Section 3.11										
Check feed & up/down chain tensions	See Section 3.15 See Section 3.16										
Check up/down gear box fluid level	See Section 3.15										
Lubricate blade tensioner handle and rods	See Section 3.10										
Inspect hydraulic lines & fittings	See Section 3.13										
Check hydraulic fluid level	See Section 3.13										
Check blade screw (or cam bearing)	See Section 3.4										
Replace hydraulic system filter (Rev E7+)	See Section 3.13										
Service Hydraulic Drive Motor (Rev C7 - E6)	See Section 3.13										
Replace cylinder drive bearing fluid	See Section 3.14										
Grease up/down shaft bearing	See Section 3.15										

SECTION 4 TROUBLESHOOTING GUIDE

4.1 Sawing Problems

<i>PROBLEM</i>	<i>CAUSE</i>	<i>SOLUTION</i>
Blades Dull Quickly	Dirty logs	Clean or debark logs, especially on entry side of the cut
	When grinding teeth, heating too much and causing teeth to soften	Grind just enough metal to restore sharpness to the teeth. Use water/coolant while sharpening blade
	Poor sharpening techniques	Make sure the tip is being sharpened completely. See Sharpener Manual.
Blades Break Prematurely	Rubber belts on blade wheels worn to a point that blade contacts metal pulley - look for shiny spots on edge of wheels	Change blade wheel belts (B-57)
	Poor sharpening techniques	See Sharpener Manual
	Tension too tight	Tension blade to recommended specifications
Blade Does Not Track Right on Drive Wheel	Cant adjustment is incorrect	Readjust
	Flat/worn belts	Replace B-57 belts
Blade Guides Do Not Spin While Cutting	Frozen bearings	Replace bearings
	Stiff bearings	Grease bearings
Blade Does Not Stop Immediately After Disengaging	Brake strap too loose	Adjust brake strap
Drive Belts Come Off Pulleys When Disengaging Blade	Brake strap too loose	Adjust brake strap
	Brake drum misaligned	Realign on drive shaft
	Brake strap tightened with one edge too loose and one edge too tight	Adjust brake strap
Drive Belts Wear Prematurely or Jump	Engine/motor and drive pulleys out of alignment	Align pulleys See Section 4.6 Engine/Motor and Drive Pulleys Alignment.

4 Troubleshooting Guide

Sawing Problems

Boards Thick Or Thin On Ends Or Middle Of Board	Stress in log which causes log to not lay flat on the bed	After log has been squared, take equal cuts off opposing sides. Take a board off the top. Turn the log 180 degrees. Take a board off. Repeat, keeping the heart in the middle of the cant, and making it your last cut
	Set in teeth	Resharpen and reset blade
	Bed rails misaligned	Realign sawmill.
Height Adjustment Jumps or Stutters When Moving Up or Down	Mast needs lubrication	Lubricate mast track surface
	Up/down chain improperly adjusted	Adjust up/down chain.
	Vertical wear pads are too tight	Adjust pads.
	Drive belt(s) loose	Adjust belts.
Lumber Is Not Square	Vertical side supports not square to bed	Adjust side supports.
	Blade not parallel to bed rails	Adjust bed rails parallel to blade.
	Sawdust or bark between cant and bed rails	Remove particles
	Tooth set problems	Resharpen and reset blade
Sawdust Builds Up On Track	Excessive oiling	Do not oil track
	Track wipers worn	Adjust wipers to firmly contact track
	Track is sticky	Clean track with solvent and apply silicone spray
Wavy Cuts	Excessive feed	Slow feed rate
	Improperly sharpened blade (This will be the problem 99% of the time!)	Resharpen blade. See Sharpener Manual - read entire manual!
	Blade guides improperly adjusted	Adjust blade guides.
	Sap buildup on blade	Use Water Lube.
	Tooth set problem	Resharpen and reset blade

4.2 Electrical Problems

<i>PROBLEM</i>	<i>CAUSE</i>	<i>SOLUTION</i>
Up/down Elevator Excessively Slow	Vertical wear pads too tight	Adjust pads.
	Up/down belt loose	Adjust belt to be as loose as possible without slipping
Up/down Or Power Feed Motors Do Not Work	Worn contacts in drum switch	Replace switch or remove control panel cover and clean contacts
	Burned-out motor	Replace motor
	Bad connection on battery post or loose wire	Check for loose wire or terminal connections
Up/Down Or Power Feed Switches Remain Engaged When Switch Is Released	Worn or dirty contacts in drum switch	Manually move the power feed or up/down switch back to neutral or "off" position. Replace drum switch or remove control panel cover and clean and lubricate contacts NOTE: Use only contact grease supplied by Wood-Mizer.
	Drum switch spring broken	Manually move the power feed or up/down switch back to neutral or "off" position. Replace drum switch spring
Up/Down Or Power Feed Motors Overheat And Loose Power	System overload or bind occurred.	Correct problem. See Section 4.3 Power Feed Problems. Allow motor to cool before restarting.
	Normal operation factors exceeded (eg: up/down control jockeyed excessively)	Allow motor to cool before restarting.
Everything Works And Then Cuts Out - Works Again	Bad connection in battery	Check connection
Nothing Works Electrically	Dead battery	Check for short circuit or turn OFF key
	Bad circuit breaker	Replace

4 Troubleshooting Guide

Electrical Problems

	Bad fuse	Replace
	Bad connection in battery	Check connections
	Corrosion on battery post	Remove connection and clean posts
Battery Will Not Stay Charged	Key switch left ON	Turn switch OFF when not in use
	Short in system	Visually check for bare wires and/or have checked
	Charging system not functioning	Have system checked by authorized Onan dealer
	Bad cells	Check fluid levels and add proper solution
	Idle improper	Adjust low end RPM
	Burned out alternator light	Check for loose wire. Replace light if necessary.

4.3 Power Feed Problems

NOTE: If the power feed circuit board has been upgraded since 9/96: The power feed circuit board is equipped with LED lights to help determine if the circuit board or feed rate switch are the cause of any feed problems you may encounter. [See Section 4.4 Power Feed Circuit Troubleshooting](#) for instructions.

PROBLEM	CAUSE	SOLUTION
Power Feed Is Jerky At Low Speeds Or Does Not Move Until Speed Is Above Halfway Mark	Drum switch is dirty	Clean drum switch and lubricate with contact grease supplied by Wood-Mizer
	Drum switch contacts are bad	Check that contacts are in good condition and positively close circuit
	Components are loose or wires are broken	Inspect PC board for loose connections and components; Send PC board to Wood-Mizer for guaranteed repair
Power Feed Is Jerky When Shaft Of Feed Rate Dial Is Moved Back And Forth	Variable speed switch is bad - perform the variable speed switch test.	Replace variable speed switch
Power Feed Is Jerky, But Power Feed Motor Runs Properly At All Speeds	Problem is mechanical.	Refer to the Mechanical Test.
Power Feed Motor Overheats	Middle track oiler is dragging	Clean middle track oiler and lubricate with 30-weight oil or ATF (Automatic Transmission Fluid) such as Dexron II. Allow motor to cool before restarting
	Ground is not level	Level mill with carpenter's level. Allow motor to cool before restarting
	Track roller bearing drag is excessive	Lubricate bearings; Replace tight bearings. Allow motor to cool before restarting
	Lower track rollers are not aligned properly	Check stop block clearance from lower bed rail. Allow motor to cool before restarting

Chain is dragging	Make sure chain is centered on cam follower bearing; Clean and lubricate chain; Adjust chain tension. Allow motor to cool before restarting
Chain is improperly tensioned	Adjust chain tension. Allow motor to cool before restarting
Seat load is excessive	Check seat bearings for freedom of movement; Loosen clamping screw 1/4 turn. Allow motor to cool before restarting
Power feed is binding	Adjust belt tension; Check condition of belt, pulleys, bearings, and sprocket; Check motor for ground fault. Allow motor to cool before restarting
Saw head load is excessive	Avoid unnecessary modifications to saw heads that would give them extra weight. Allow motor to cool before restarting
Blade is dull or improperly set	Use proper blade maintenance procedures. See Sharpener or Toothsetter manual . Allow motor to cool before restarting

4.4 Power Feed Circuit Troubleshooting

On circuit boards after 9/96, LED lights are provided to help determine if the circuit board or feed rate switch are the cause of any feed problems you may encounter.

See Figure 4-1. The lights can be viewed by removing the front control box panel.

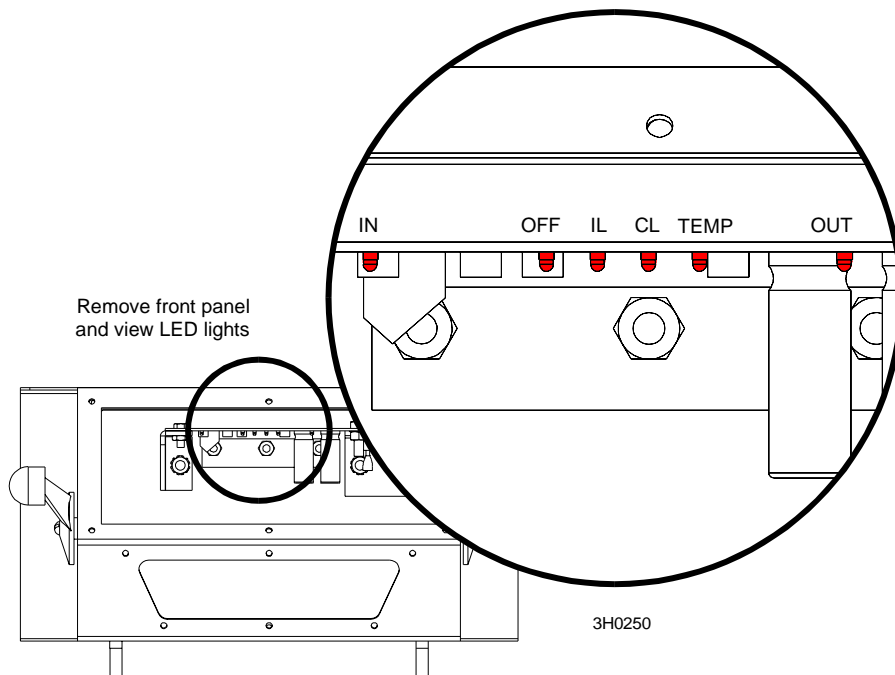

FIG. 4-1

If you have trouble determining the problem indicated by the LED lights, please note which lights are on and call customer service for assistance.

IN - This light normally dims and brightens as the feed rate switch is turned up or down. If the light does not correspond to the feed rate switch, the switch has failed or is not wired correctly.

OFF - This indicator is active anytime the TEMP, CL or IL light is active. This light indicates the shutdown circuit has been activated. If the light comes on without the CL, IL, or TEMP light also on, the circuit board is wet or defective. If you determine the board is not wet, replace it.

IL - This light indicates the circuit board has detected a failure of the output circuit protection or that the power feed motor has been replaced with a motor not provided by Wood-Mizer. The light will flash about once every second and will deactivate the output

circuit. If the power feed motor is a Wood-Mizer replacement, replace the circuit board.

CL - This light indicates an extreme overload condition of the power feed motor or a short in the wiring between the motor and circuit board. The light will flash about once every second and deactivate the feed system until the problem is corrected.

TEMP - When lit, this light indicates the temperature of the output circuit is too high and will shut off the circuit. Once the circuit cools, the light will go off and the feed will become operational. Temperatures become too high when the power feed motor is overloaded.

OUT - This light normally dims and brightens at the same rate as the IN light when the feed rate switch is turned up and down. If the OUT light does not correspond with the IN light, replace the circuit board.

4.5 Hydraulic Problems

<i>PROBLEM</i>	<i>CAUSE</i>	<i>SOLUTION</i>
You Can Actuate Any Hydraulic Handle, But Get No Response From The Pump.	Carriage not positioned properly to provide power to the pump	Move carriage so that contacts touch. Make sure carriage contact bracket is adjusted far enough forward to touch contact on main tube. Check contacts for tarnish or loose wires
	Defective solenoid (may be indicated by solenoid clicking) See Monarch manual for troubleshooting solenoid	Tapping on solenoid may fix temporarily. Replace solenoid. NOTE: The solenoid is not a standard automotive type. Order from Monarch or Wood-Mizer only
	Low or dead battery	Test battery. Replace or recharge as necessary
	Defective pump motor	Remove motor from pump and inspect. Repair or replace as necessary
You Can Get Response From the Pump By Actuating All But One or Two Handles (Revisions E7+ Only)	Poor ground connection	Check ground connection between pump and saw frame
	Valve assembly switch contacts are not properly adjusted	Locate the valve switch at the bottom of the valve assembly. Use a 3MM allen wrench to loosen the set screw on each of the five switch contacts. Press each contact to the valve block and tighten the contact set screw to secure in place. CAUTION! Do not overtighten! NOTE: Do not adjust the valve switch or switch spring; they have been preset at the factory.
You Can Get Response From The Pump By Actuating All But One Handle (Revisions C7 - E6 Only)	Electric contact spring inside of non-working valve corroded, broken, or dislocated	Check contact spring. Relocate or replace as necessary
	Set screw holding handle to valve shaft is loose	Tighten set screw so that valve shaft turns when handle is actuated

4 Troubleshooting Guide

Hydraulic Problems

Pump Motor Runs With Little Or No Response From The Cylinders	Low battery	Test battery. Recharge or replace as necessary
	Debris clogging pressure relief valve (<i>Revisions C7 - E6 Only</i>)	Clean pressure relief valve. See Mon-arch manual.
	Low fluid level	Check fluid level. Add an all-season hydraulic fluid such as Amoco Rycon Oil MV or Mobil Multipurpose ATF (automatic transmission fluid) until level is 4 - 4 1/2" from bottom of reservoir with all cylinders retracted
	Pressure relief valve moved from proper setting	Adjust pressure relief valve.
Pump Motor Runs Continuously When Power Contact Is Made	Low air temperature causing fluid to thicken	Allow fluid to warm up. Synthetic fluids are available that allow for hydraulic operation in cold weather conditions (Univis HVI 13)
	Solenoid is stuck closed	Tapping the solenoid may solve this problem temporarily. Replace solenoid
	Valve handle spring is deformed or broken, causing the handle to not return to the neutral position (<i>Revisions C7 - E6 Only</i>)	Replace handle spring
Fluid Leaks From Around Cylinder Piston Ram	Contact spring is dislocated and lying across contacts (<i>Revisions C7 - E6 Only</i>)	Replace contact spring
	Worn seals	Replace seals in cylinder. Check piston ram for abrasive weld that may be causing premature seal failure

Fluid Leak Around Pump Box	Loose seal or fitting	Wipe pump off completely to locate cause of leak. You may have to unbolt the pump to wipe behind it. NOTE: Movement of the sawmill can cause fluid to slosh up into the foam filter in the reservoir cap, and subsequently spray out, giving the appearance that fluid is leaking from the pump
Hydraulic Side Supports Go Down Before Or At Same Time As Log Turner	Dirt in sequence valve	Remove sequence valves and clean thoroughly with kerosene. NOTE: Be sure to reassemble the valve and install it in its original position on the cylinder
	Retainer in sequence valve worn	Replace sequence valve
	Low air temperature causing fluid to thicken	Allow fluid to warm up. Synthetic fluids are available that allow for hydraulic operation in cold weather conditions (Univis HVI 13)
Hydraulic Turner Goes Up Before Or At Same Time As Side Supports	Spring weakening in sequence valve	Locate sequence valve at top of turner cylinder. Turn heavy spring in about 1/4 turn
	Dirt in sequence valve	Remove sequence valves and clean thoroughly with kerosene. NOTE: Be sure to reassemble the valve and install it in its original position on the cylinder
	Retainer in sequence valve worn	Replace sequence valve
	Low air temperature causing fluid to thicken	Allow fluid to warm up. Synthetic fluids are available that allow for hydraulic operation in cold weather conditions. (Univis HVI 13)
	Springs weakening in sequence valve.	Locate sequence valve at bottom of turner cylinder. Turn heavy spring in about 1/4 turn

4.6 Engine/Motor and Drive Pulleys Alignment

1. Install the drive belt.
2. Use a straight edge to align the engine/motor pulley to the drive pulley. Also check that the engine pulley is within 1/8" square with the drive pulley. Loosen the engine mounting bolts and rotate the engine if necessary.
3. Check front-to-back movement of the engine does not exceed 1/4". Tighten the motor mount U-bolts if necessary.
4. Engage the clutch handle and adjust the drive belt tension to 7/16" deflection with 10 lb. of force.
5. Recheck the pulley alignment and engine squareness with the clutch handle engaged. Adjust if necessary.
6. Adjust the drive belt support to 1/4" ($\pm 1/32$) from the belt while engaged.

4.7 Power Feed Variable Speed Switch Test

With the feed rate dial switch all the way down, move the shaft of the dial back and forth to see if there is a jerky response. Turn the dial and move the shaft back and forth again. Repeat several times. If the jerkiness occurs at the same location on the dial several times, you need to replace the variable speed switch.

4.8 Power Feed Preliminary Test

This test will determine if the problem is a mechanical or electrical.

1. Remove the drive belt from the power feed drive pulley.
2. Turn the key switch to the ACC position. Put the carriage fwd/rev switch into the forward position and turn the feed rate dial through all speeds. If the power feed motor runs properly at all speeds, the problem is a mechanical one instead of an electrical one.

4.9 Power Feed Mechanical Test

1. Remove the weight from the track rollers. They should turn smoothly and easily with very little play.
2. Make sure the middle track cover is not bent or touching the top rail.
3. Make sure the middle track oiler, if applicable, is free of sawdust buildup.
4. Make sure the power feed chain is not stiff from rust. Also make sure the chain is not too tight.
5. Check the power feed shaft. Visually inspect the bearings. The shaft should move neither in or out nor side to side.
6. Make sure the power feed chain cam bearing is not touching the main frame tube.
7. If you have an old-style mill with loop-designed feed chain, inspect the front and rear sprocket assemblies. Make sure there are no defective bearings.
8. Make sure there is no sap or rust on the rails.
9. Make sure the block on the lower track roller assembly is not rubbing the lower rail. Also make sure the track rollers are not too tight.
10. Make sure the power feed belt is properly tightened.

4.10 Hydraulic Pressure Test

To check hydraulic pressure on E7+ revision LT30HD/LT40HD mills:

1. Disconnect power from the pump by moving the saw head forward until it no longer contacts the power strip.
2. Locate the loading arm port fitting on the hydraulic valve body.

See Figure 4-2.

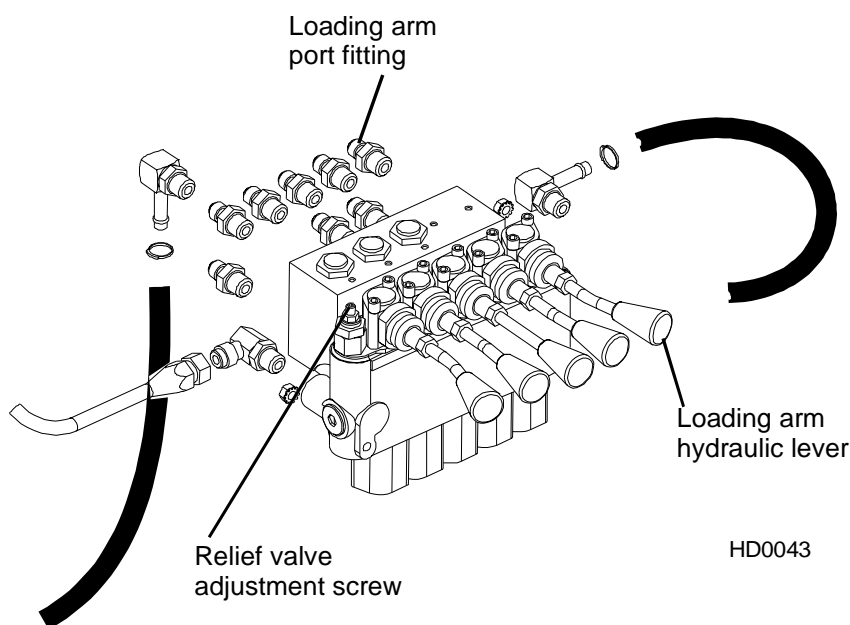

FIG. 4-2

3. Disconnect the hydraulic hose from the fitting and install a gauge to the fitting. **NOTE:** Installing the gauge at the loading arm fitting port will insure the pressure reading is not affected by a relief valve.
4. Restore power to the pump by moving the saw head back until it contacts the power strip.
5. Operate the loading arm hydraulic lever and read the pressure on the gauge. Hydraulic pressure is factory-set at 2000 ± 100 psi and should not need to be readjusted. The relief valve adjustment screw shown may be used to fine-tune the hydraulic pressure.



CAUTION! Pressure should not exceed 2100 psi. If it does, the amp draw will rise above the maximum of 200 amps, and could cause battery and system problems.

To check hydraulic pressure on C7 - E6 revision LT30HD/LT40HD mills:

1. Disconnect power from the pump by moving the saw head forward until it no longer contacts the power strip.
2. Locate the fitting on the front toe board cylinder. Disconnect the hydraulic hose from the fitting and install a gauge to the fitting. **NOTE:** Installing the gauge at the front toe board fitting port will insure the pressure reading is not affected by a relief valve.
3. Restore power to the pump by moving the saw head back until it contacts the power strip.
4. Operate the toe board hydraulic lever and read the pressure on the gauge. Hydraulic pressure is factory-set at 2000 ±100 psi and should not need to be readjusted. Contact the factory for service.



CAUTION! Pressure should not exceed 2100 psi. If it does, the amp draw will rise above the maximum of 200 amps, and could cause battery and system problems.

SECTION 5 SAWMILL ALIGNMENT

5.1 Pre-Alignment Procedures

The Wood-Mizer sawmill is factory aligned. Periodically check the sawmill alignment and adjust if necessary. This chapter explains how to align the entire sawmill. Care should be taken in performing these steps. Sawmill alignment determines the accuracy and squareness of your cuts.

The sawmill alignment steps are:

1. Ready the sawmill for alignment
2. Adjust the main bed rails parallel to the blade
3. Adjust the blade guide arm parallel to the bed rails
4. Align blade guides to the blade
5. Adjust side supports square to the bed
6. Adjust pivot bed rails parallel to the blade
7. Final Adjustments

To insure accurate alignment, the sawmill frame must be level and a blade properly installed.

5.2 Frame Setup

Stationary sawmills should be setup on firm, level ground before proceeding with alignment. Shim the feet so the weight of the sawmill is evenly supported.

Portable sawmills should also be setup on firm, level ground. Adjust the two middle outriggers on the main frame tube down just enough to lift weight from the trailer tire.

Adjust the two outer outriggers down just so they touch the ground but do not bear weight.

5.3 Blade Installation And Alignment

See Figure 5-1. Install a blade and apply the appropriate tension ([See Section 2.5 Tensioning The Blade](#)). Blade tension is adjusted with the tension handle shown.

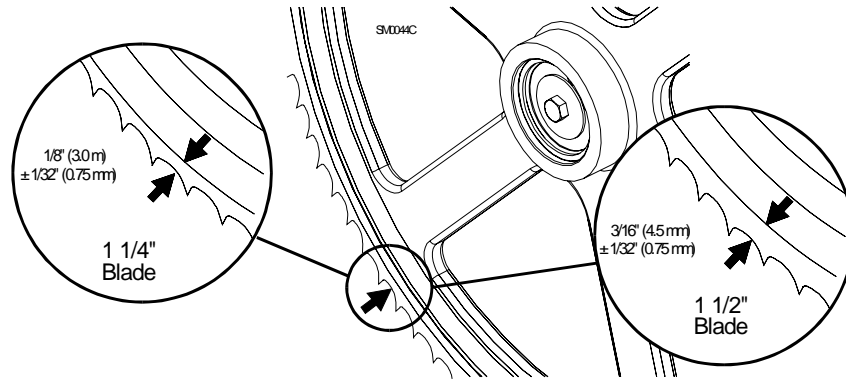

FIG. 5-1

Check the vertical alignment of the blade wheels. The gullet of the blade should ride the same distance from the front edge of the wheel at the top, bottom, and side of the wheel. If it does not, loosen and tighten the appropriate adjustment screws on the back of the wheel. **See Figure 5-1**

See Figure 5-2. The blade wheels should be adjusted so that the gullet of 1 1/4" blades ride 1/8" (3 mm) out from the front edge of the wheels (±1/32 [.75 mm]). The gullet of 1 1/2" blades should ride 3/16" (4.5 mm) from the front edge of the wheels (±1/32 [.75 mm]). Do not let the teeth ride on the wheels.

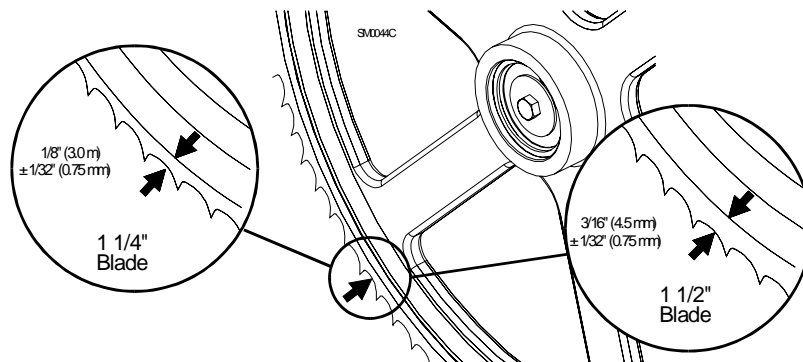

FIG. 5-2

To adjust where the blade travels on the idle-side blade wheel, use the cant control shown in **Figure 5-1**.

1. Start the engine. Pull lightly on the clutch handle to rotate the blade until it locates itself on the blade wheels. If the blade is too far forward on the wheels, turn the cant control counterclockwise. If it is too far back on the wheels, turn the cant control clockwise.
2. Some adjustment in blade tension may be needed to compensate for adjustments made with the cant control.

Adjustment with the cant control handle is usually all that is required to track the blade properly on both blade wheels. The drive-side blade wheel will usually not have to be adjusted. If necessary, the drive-side wheel can be adjusted as follows:

Look at the drive shaft from the side. Locate the U-bolt on the right holding the bearing housing to the mounting plates.

Locate the jam nuts on the U-bolt between the two mounting plates. If the blade is running too far to the front of the drive-side blade wheel, turn the jam nuts toward the bearing housing. If the blade is too far back, turn the nuts away from the bearing housing.

Make sure to tighten the jam nuts against the mounting plates when adjustment is complete.

5.4 Saw Head Slide Pad Adjustment

There are eight nylon pads positioned between the saw head frame and vertical mast. The spacing of the pads is factory set and rarely needs adjusting. To check the pad spacing, perform the following steps.

NOTE: The pads on the engine side of the mast are referred to as the "inner" pads. The pads on the control side of the mast are referred to as the "outer" pads.

NOTE: Shims are often used around the clamping bolts, between the C-frame support bracket and the mast v-brace. The shims align the v-brace to the mast so that the entire face of each slide pad makes contact with the mast. Be sure to keep these shims in place when performing the following adjustment.

See Figure 5-3.

1. Raise the saw head to the top of the vertical mast. Check the top set of four pads. The outer two pads should be touching the mast rails. There should be a small gap (just wide enough to slide a business card through) between one of the inner pads and the mast rail.



DANGER! Always secure the cutting head with a 5/16" chain with at least 1900 lbs. working load capacity before adjusting the mast pads. The cutting head may fall, causing severe injury or death.

2. To adjust the spacing of the upper set of pads, lower the saw head until you can access the upper slide pad adjustment bolts.
3. Loosen the upper locking bolts and turn the adjusting bolt as necessary to provide the pad spacing described in Step 1.
4. Lower the saw head to the bottom of the vertical mast. Check the bottom set of four pads.

There should be a small gap between one of the outer pads and the mast rail. The gap should be just wide enough to slide a business card through. The inner two pads should be touching the mast rails. To adjust the spacing of the lower set of pads, raise the saw head until you can access the lower slide pad adjustment bolts.

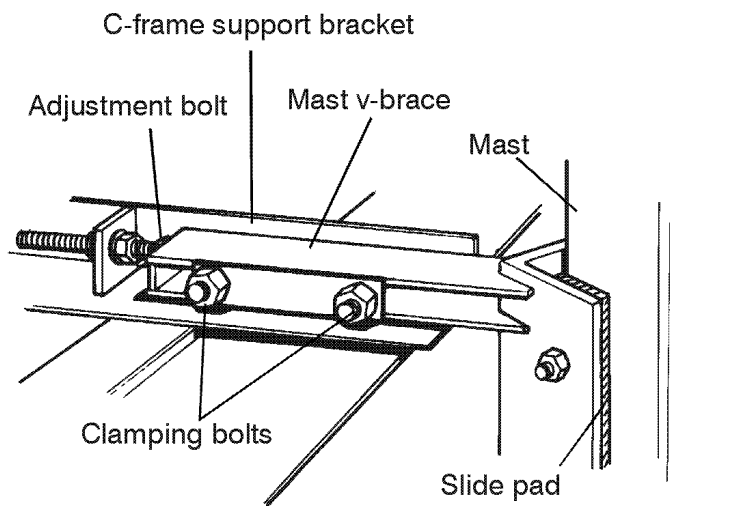

SM0061

FIG. 5-3

5. Loosen the lower locking bolts and turn the adjusting bolt as necessary to provide the pad spacing described in Step 4.



CAUTION! Due to variations in the vertical mast, the pad spacing may vary throughout the travel of the saw head. Check the pad spacing at the top and bottom ends of the mast only. Pads adjusted too tight will cause premature up/down motor failure.

5.5 Adjusting The Lower Track Rollers

Making these adjustments correctly will give you square cuts and accurate dimensions across the width of your boards.

1. Move the saw carriage so the blade is over the rear main bed rail.

See Figure 5-4.

2. Check that both lower track rollers are touching the inside of the rail. The stop-blocks should be within 1/16-1/8" (1.5-3.0 mm) of the rail.
3. If adjustment is needed, use the horizontal bolts to pull the track rollers to the rail. Adjust the lower rollers until they both support the weight of the saw head evenly.
4. Use the vertical bolts to close the stop-block gap within 1/16-1/8" (1.5-3.0 mm) from the rail.

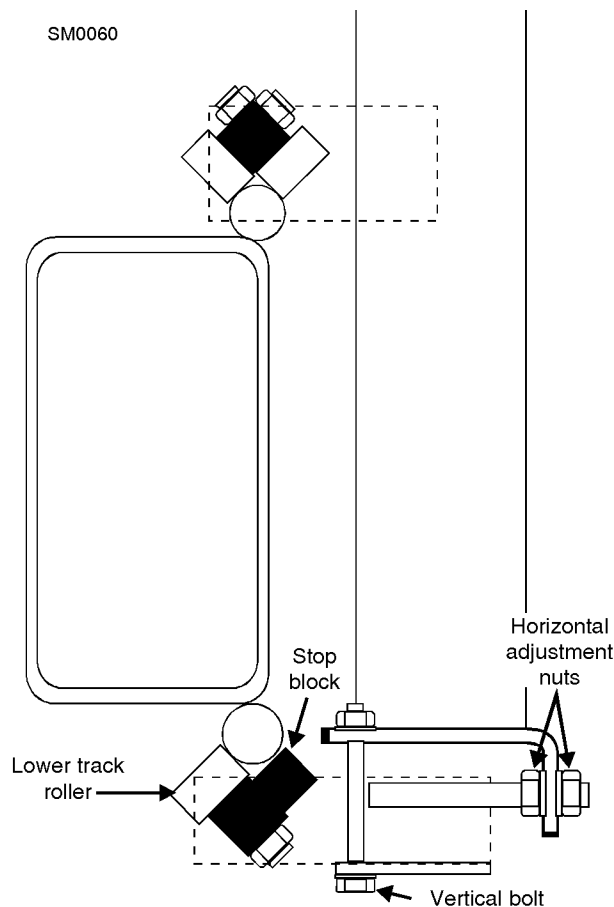

FIG. 5-4

5

Sawmill Alignment

Adjusting The Lower Track Rollers

5. Repeat this step with the blade over the front main bed rail.
6. Move the carriage from the front of the mill to the back. Watch the lower rollers and stop blocks. Make sure the gap between the rail and both stop-blocks never goes over the 1/16-1/8" (1.5-3.0 mm) tolerance.
7. Repeat, running the head from the back to the front of the mill. Make adjustments as needed.

NOTE: Adjustments of the lower track rollers change the angle between the cutting head and sawmill bed rails. Only small adjustments of the lower track rollers should ever be needed.

8. Remove the blade guides, or adjust them so that they do not touch the blade.
9. Open the adjustable blade guide arm to within 1/2" (15 mm) of full open.
10. Move the carriage so that the blade is over the log clamp tube.
11. Raise the cutting head until the bottom of the blade is 17" (400 mm) above the clamp tube by actual measurement with a tape or ruler.

See Figure 5-5.

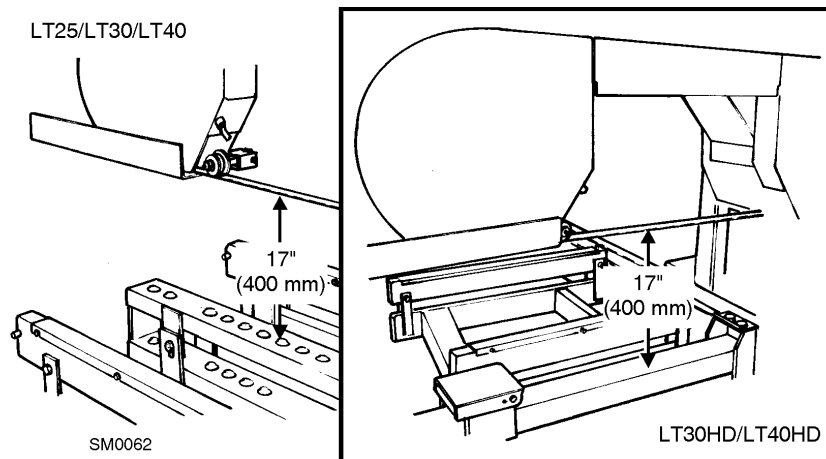

FIG. 5-5

12. Fine tune the lower track roller adjustment so the blade is parallel within 1/32" (0.75 mm) to the clamp tube while maintaining proper roller and stop block alignment outlined in Steps 1-7.

5.6 Adjusting Main Bed Rails To Blade

1. Move the clamp all the way out to flip the clamp down if necessary. Adjust the clamp until it is positioned under the outer blade guide.
2. Move the saw head until the blade is centered over the clamp.
3. Raise the saw head until the blade measures 14 1/2" (360 mm) from the top of the clamp. Use a rule to determine the actual distance of the blade to the clamp.

See Figure 5-6.

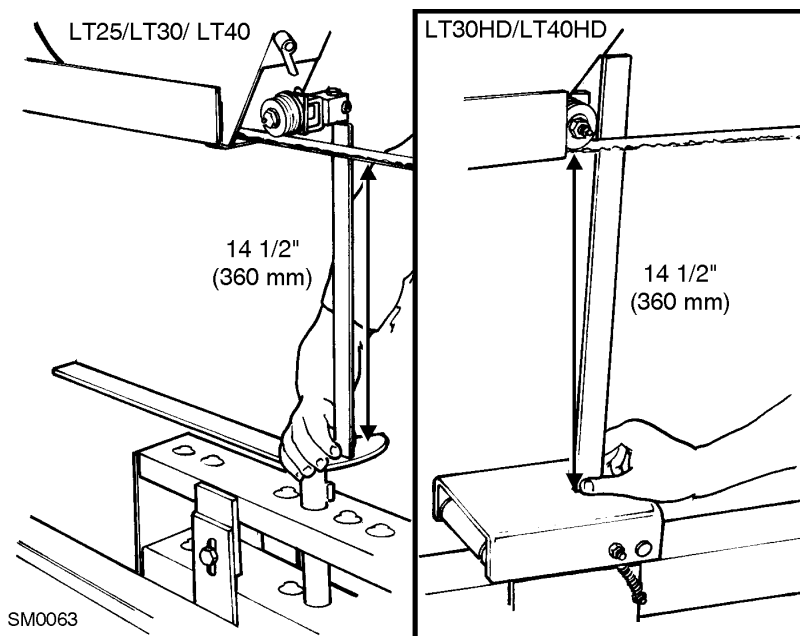

FIG. 5-6

4. Move the saw head to center the blade over the rear-most bed rail.

5 Sawmill Alignment

Adjusting Main Bed Rails To Blade

See Figure 5-7.

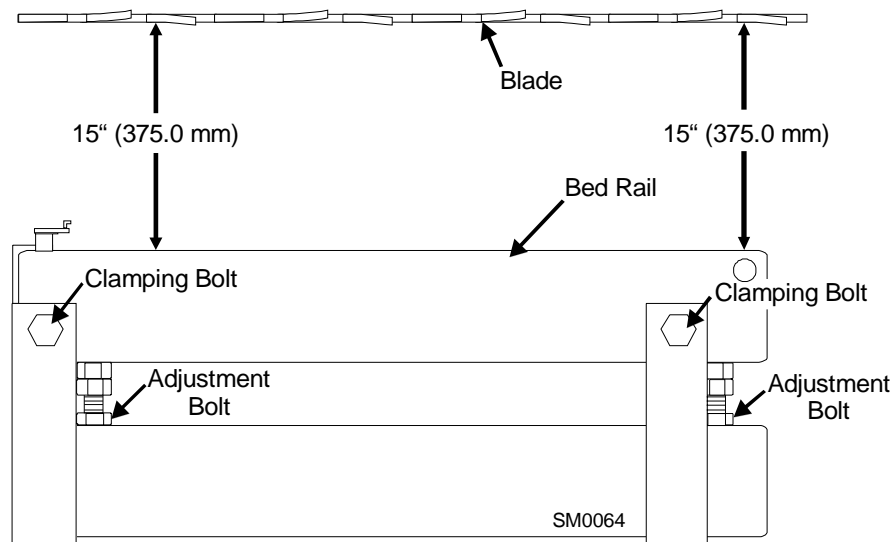

FIG. 5-7

5. Measure the distance between the bottom of the blade and the bed rail at each end of the bed rail. The bed rail should measure 15" (375 mm) (+1/32 [0.75 mm] -0) from the blade at both ends of the rail.
6. Loosen the bed rail clamping bolts and turn the adjustment bolts to move the bed rails to the blade if necessary.
7. Retighten the clamping bolts.
8. Without adjusting the saw head height, check all four main bed rails. Adjust them so that all measure the same distance from the blade at both ends of the bed rail.

5.7 Blade Guide Arm Vertical Adjustment

1. Move the saw head so that the blade guide arm is directly over a bed rail.
2. Adjust the blade guide arm out to within 1/2" (15 mm) of full open.
3. Put a block of wood between the bed rail and the arm. Lower the carriage so that the arm just rests on the block.

See Figure 5-8.

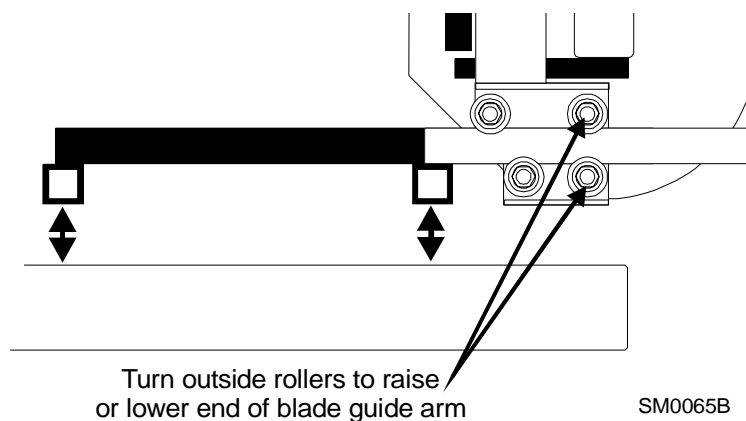

FIG. 5-8

4. Adjust the blade guide arm in to within 1/2" (15 mm) of full closed. Put the block under the arm as before.
5. When the arm is parallel to the bed, it will touch the block in the open and closed position with no adjustment of the saw head height.
6. If the arm is too low in the closed position, loosen the lower outside roller and tighten the upper outside roller (See Step 8.)
7. If the arm is too high in the closed position, loosen the upper outside roller and tighten the lower outside roller (See Step 8.)
8. The rollers are mounted on cam bolts that raise or lower the arm when turned. To adjust the rollers, loosen the nut against the blade housing. Locate the cam bolt head inside the housing and turn until the arm is lowered or raised as needed. Recheck the arm in both the open and closed positions. Repeat adjustments until the arm is the same distance from the bed rail in the open and closed position.
9. The blade guide arm should be snug, but not too tight, in the rollers. You should be able to move it in and out with firm hand pressure. There should be no side-to-side play.

5.8 Blade Guide Arm Horizontal Adjustment

1. Put the blade guide assembly back in the arm (if you took it out). Put the assembly back so that the flanged collar on the roller is about 1/8" (3.0 mm) from the back of the blade when the throat is 1/2" (15 mm) from full open.
2. Close the throat to within 1/2" (15 mm) from fully closed. Check to see that the flange is the same distance from the back of the blade.

See Figure 5-9.

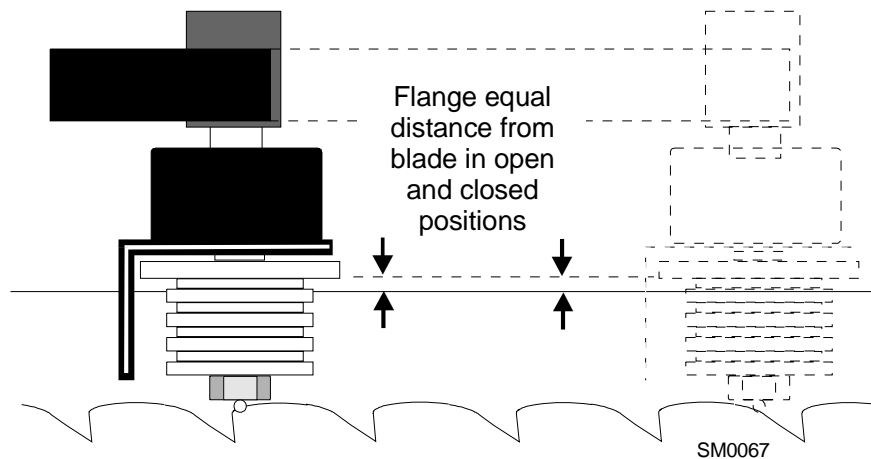

FIG. 5-9

3. If adjustment is needed, the guide rollers can be adjusted in or out on the threaded mounts to open or close the gap.

See Figure 5-10.

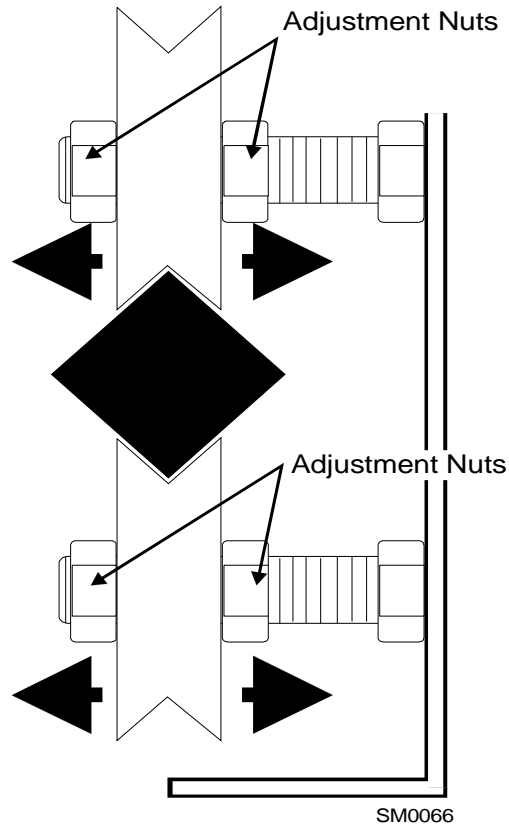

FIG. 5-10

4. Adjusting the inside two rollers (furthest from the arm motor) inward will cause the flange to move toward the blade.
5. Adjusting the two inside rollers outward will cause the flange to move away from the blade.
6. Adjust until the roller flange is the same distance from the back of the blade in the open and closed position.

5.9 Aligning The Blade Guides

Each Wood-Mizer sawmill has two blade guide assemblies that help the blade maintain a straight cut. The two blade guide assemblies are positioned on the saw head to guide the blade on each side of the material being cut.

One blade guide assembly is mounted in a stationary position on the drive side of the saw head. This assembly is referred to as the "inner" blade guide assembly.

The other blade guide assembly is mounted on the idle side of the saw head. It is referred to as the "outer" assembly and is adjustable for various widths of materials to be processed.

Blade guide alignment includes four steps:

- Blade Deflection
- Blade Guide Vertical Tilt
- Blade Guide Flange Spacing
- Blade Guide Horizontal Tilt

Perform the blade guide alignment after you have aligned the blade on the wheels and adjusted the blade and blade guide arm parallel to the bed rails. After blade guide alignment, check the scale indicator to make sure it is adjusted properly ([See Section 5.20 Blade Height Scale Adjustment](#)).

5.10 Blade Deflection

Perform the following steps to achieve proper blade deflection with the blade guides.

1. Raise the carriage until the blade is 15" (375 mm) above a bed rail. Measure the actual distance with a tape from the top of the rail to the bottom of the blade.
2. Install the blade guides. Make sure the two set screws shown are threaded into the blade guide shaft until they touch each other.

See Figure 5-11.

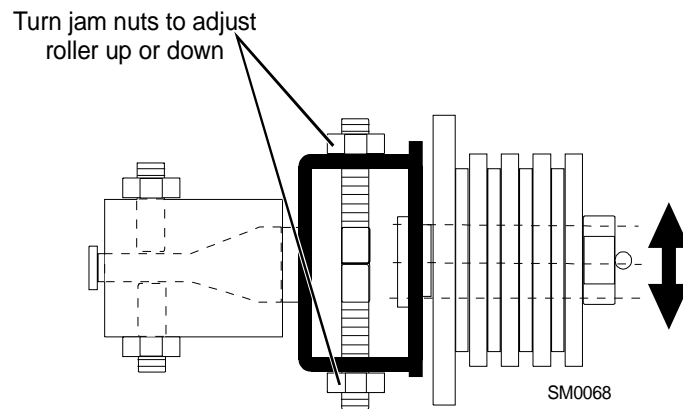

FIG. 5-11

3. Loosen the bottom jam nut and tighten the top jam nut until the blade guide deflects the blade down 1/4" (6.5 mm).
4. Repeat for the other blade guide.

NOTE: Be sure that the blade guard clears the blade on both guide assemblies. The guard on the outer guide assembly should be checked with the arm all the way in and all the way out.

5.11 Blade Guide Vertical Tilt Adjustment

Check that the blade guide does not tilt the blade up or down. A Blade Guide Alignment Tool (BGAT) is provided to help you measure the vertical tilt of the blade.

1. Open the adjustable blade guide arm 1/2" (15 mm) from full open.
2. Clamp the alignment tool on the blade. Position the tool close to a blade guide roller. Be sure the tool does not rest on a tooth or burr, and is lying flat on the blade.

See Figure 5-12.

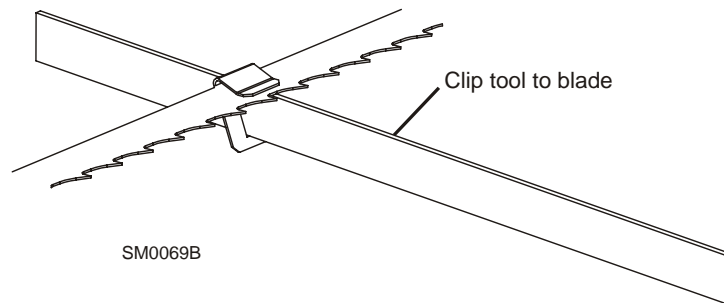

FIG. 5-12

3. Measure the distance from the bed rail to the bottom of the tool.

NOTE: If the sawmill is equipped with stainless steel bed rail covers, be sure to measure from the blade guide alignment tool to the top surface of the cover rather than the bed rail tube.

4. Move the carriage so that the front end of the tool is positioned above the bed rail.
5. Measure the distance from the bed rail to the bottom edge of the tool.
6. Loosen one set screw at the side of the blade guide assembly.
7. Use the set screws shown to tilt the blade guide until the measurement from the bed rail to the tool equals the first measurement taken at the center of the tool.

See Figure 5-13.

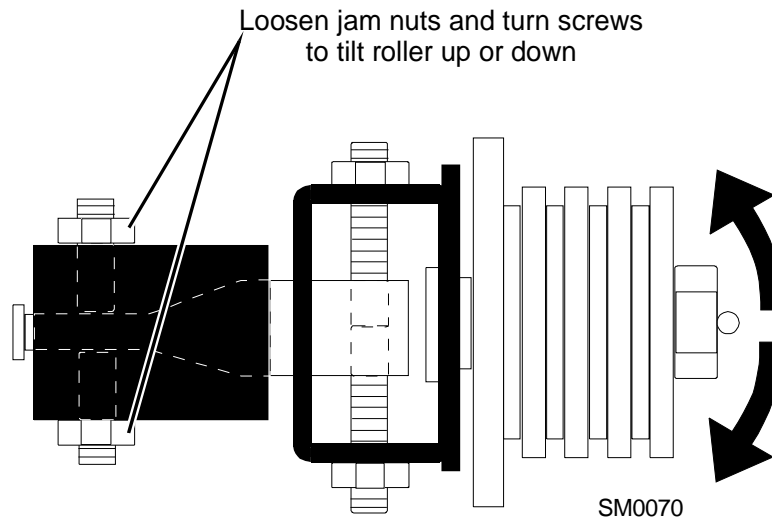

FIG. 5-13

8. Move the carriage forward so the back end of the tool is over the bed rail.
9. Use the set screws shown to adjust the blade guide tilt until the measurement from the bed rail to the tool equals the other two measurements taken.
10. Move the tool close to the other blade guide and repeat the previous steps.

NOTE: If major adjustments to blade guide tilt were made, remeasure the distance between the blade and the bed rails to ensure the correct 1/4" (6.5 mm) blade guide deflection. Adjust if necessary.

5.12 Blade Guide Spacing

HINT: When adjusting blade guide spacing, loosen the top set screw and one side set screw only. This will insure horizontal and vertical tilt adjustments are maintained when the set screws are retightened.

1. Adjust the inner blade guide so the blade guide flange is approximately 1/16" (1.5 mm) from the back of the blade.
2. Loosen one side and one top set screw shown. Tap the blade guide forward or backward until properly positioned.

See Figure 5-14.

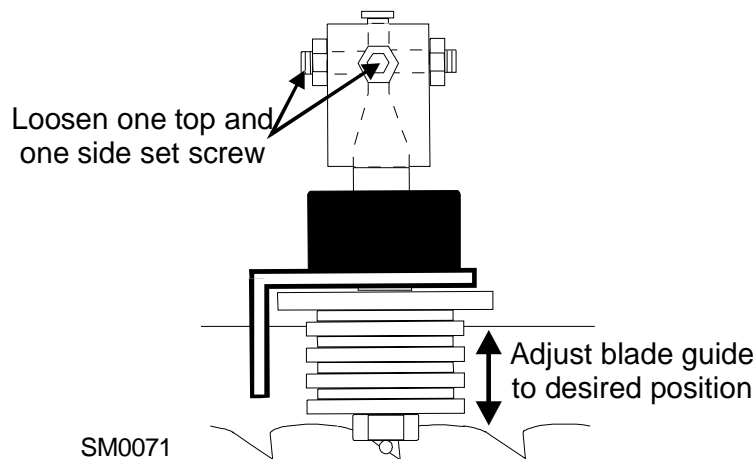

FIG. 5-14

3. Retighten the two set screws.
4. Adjust the outer blade guide in the same way so the blade guide flange is approximately 1/8" (3.0 mm) from the back of the blade.

5.13 Horizontal Tilt Adjustment

1. Finally, both blade guides must be tilted horizontally. Adjust the blade guide arm half way in.

See Figure 5-15.

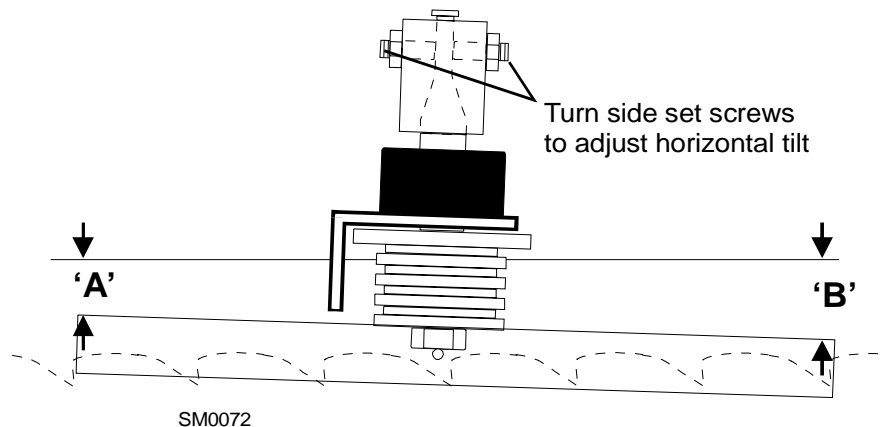

FIG. 5-15

2. Place Blade Guide Alignment Tool against the face of the outer blade guide roller.
3. Center the tool on the roller and measure between the back edge of the blade and the ruler at the end closest to the inner blade guide ("B").
4. Measure between the back edge of the blade and the other end of the ruler ("A").
5. The roller should be tilted slightly to the left ('A' 1/8" [3 mm] less than 'B' \pm 1/8" [3 mm]).
6. Use the side set screws to adjust the horizontal tilt of the roller.
7. Repeat Steps 3 - 7 for the inner blade guide roller.

NOTE: Once the blade guides have been adjusted, any cutting variances are most likely caused by the blade. [See Blade Handbook, Form #600.](#)

5.14 Horizontal Adjustment Of Side Supports

The side supports are used to clamp flats on a log to set the squareness of the next cut. The cut will only be as square as the supports.

1. Swing the side support down.
2. Measure between the face of the support and the main bed tube. Make measurements at both ends of the side support to make sure that it is parallel to the rail.

See Figure 5-16.

3. Use the two lower bolts to adjust the side support so $B=A + 1/32"$ (0.8 mm).
4. Repeat for remaining side supports.

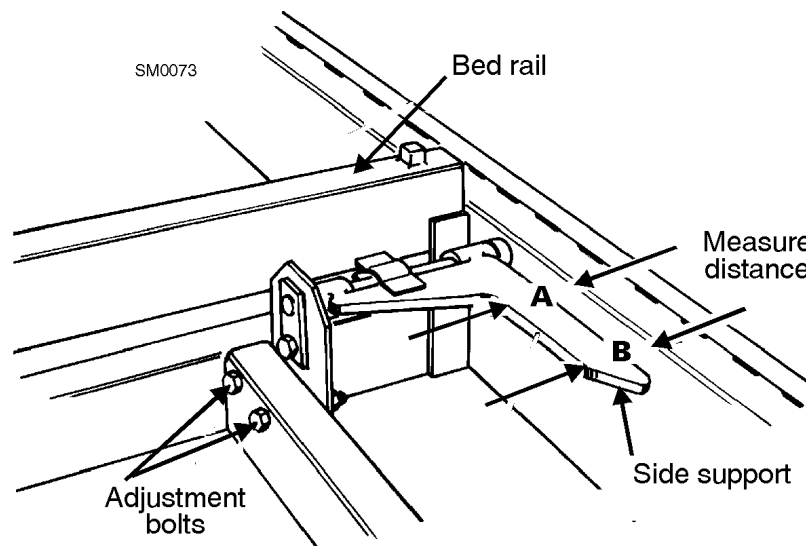

FIG. 5-16

5.15 Vertical Adjustment Of Side Supports

1. Place a flat board across the bed rails.
2. Swing a side support up so that it is vertical.
3. Pull back at the top of the support to eliminate slack as if a log were being clamped against it.

See Figure 5-17.

4. Check the angle of each support with a square on the board.
5. The side support should be 90° to the bed rails or leaning forward 1/32" (0.8 mm). Loosen the top adjustment bolt, adjust the side support, and retighten the bolt.
6. Repeat for the remaining side supports.

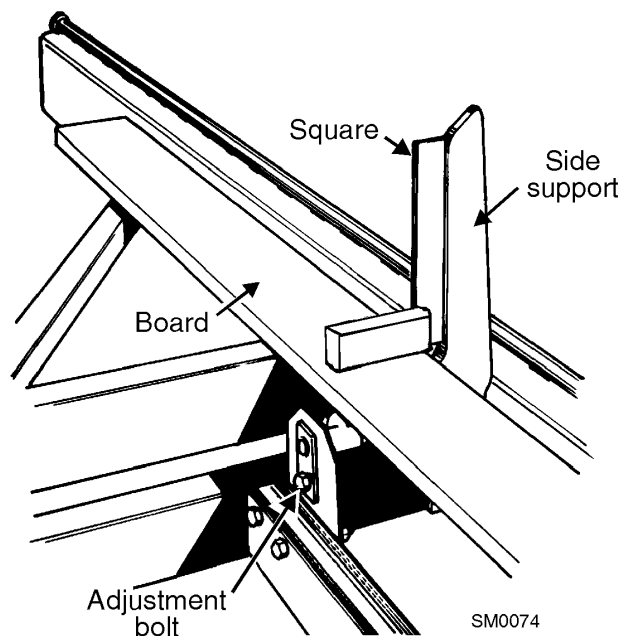

FIG. 5-17

5.16 Clamp Stop Adjustment

1. Once the side supports are aligned, pivot them down to their horizontal position.
2. Tie a string across the face of the side supports.

See Figure 5-18.

3. Loosen the clamp stop bolts and adjust the clamp stop until it touches the string.

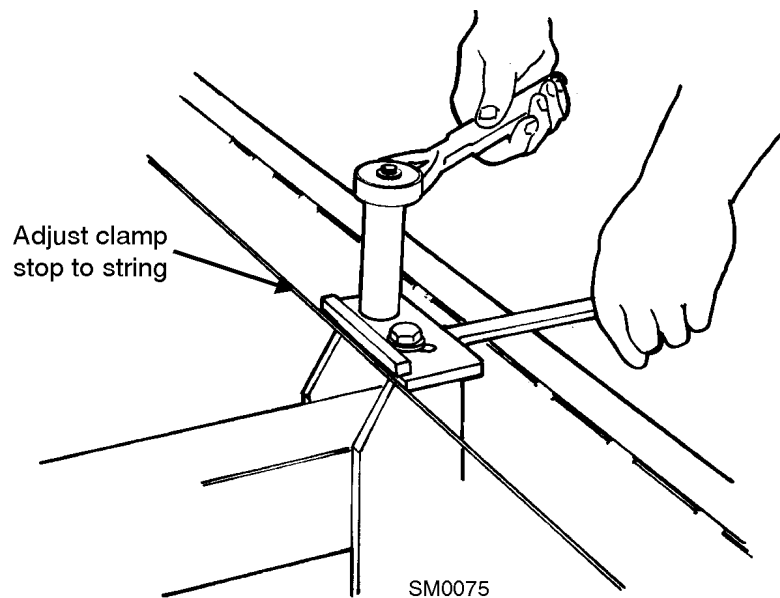

FIG. 5-18

5.17 Aligning The Pivot Bed Rails

The two pivot bed rails are used when long cants are cut. (Long cants will often bend down at the ends.) The pivot bed rails need to be adjusted to the same level as the main bed rails.

To adjust the pivot bed rails:

1. Adjust the pivot rail 90° to the main bed tube.
2. With the saw head raised so the blade is 14 3/4" from the main bed rails, move the saw head so that the blade is over one of the pivot bed rails.
3. Measure the distance from the top of the pivot rail to the bottom of the blade. Make this measurement at each end of the pivot rail.
4. The two measurements should be the same as the main bed rails.
5. Use the bolt shown to adjust the height of the pivot rail.

See Figure 5-19.

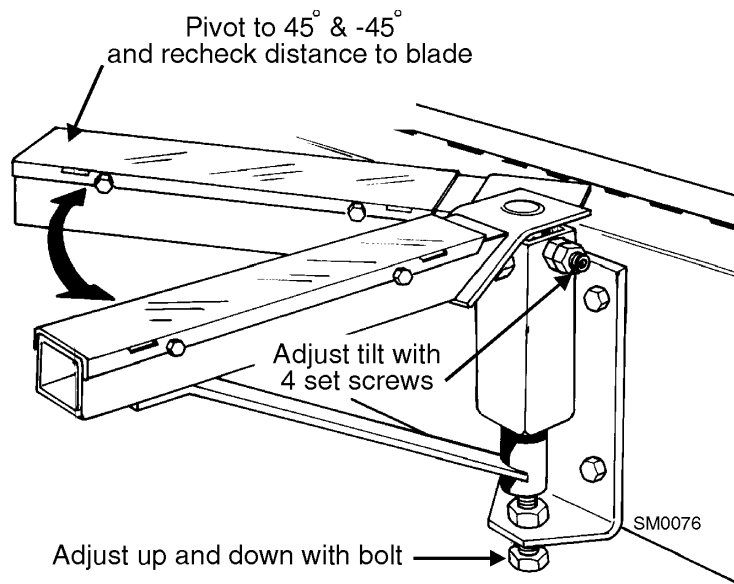

FIG. 5-19

6. Use the set screws to adjust the angle of the pivot rail. Pivot the rail and check in 45° positions as shown.

5

Sawmill Alignment

Aligning The Pivot Bed Rails

7. Adjust as needed until the pivot rail measures the same distance ($\pm 1/32$) from the blade in the 45°, 90°, and -45° positions.



CAUTION! Do not roll logs or large cants onto pivot bed rails.



IMPORTANT! Logs and large cants will damage the pivot bed rails or cause misalignment!

5.18 Sight Gauge Adjustment

After adjustments to the bed rails and blade guides are complete, adjust the sight gauge so that it accurately shows the position of the blade over the bed rails.

1. Move the saw head so the sight gauge is positioned over a bed rail.
2. Measure from the bed rail to the top of the sight gauge spring.
3. Loosen the nuts securing the sight gauge and adjust until the top of the spring is the same distance from the bed rail as the blade.
4. Retighten the sight gauge nuts.
5. Bend the sight gauge bracket so the spring is parallel to the bed rails.

5.19 Saw Head Tilt

As the blade enters a wide log or cant, the outside of the saw head will drop down slightly. To compensate for the drop, use the lower track roller horizontal bolts to raise the outside of the saw head 1/16".

1. Move the saw head so the blade is positioned 14 3/4" (375 mm) above a bed rail.
2. Adjust the lower track roller horizontal bolts until the blade measures 14 13/16" (376.5 mm) from the bed rail near the outer blade guide.

See Figure 5-20.

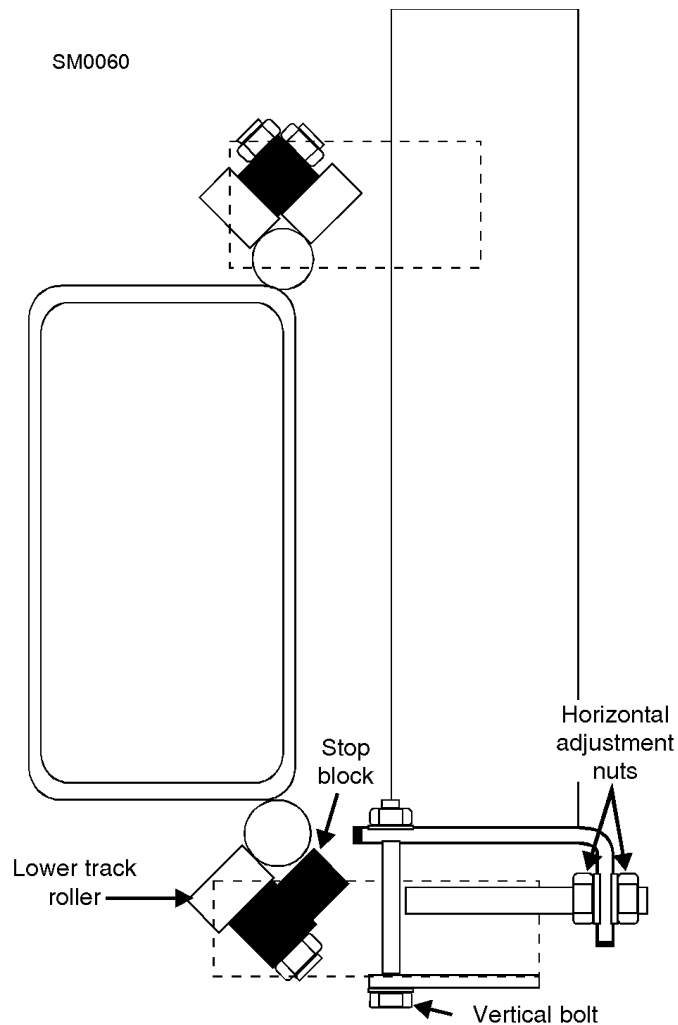

FIG. 5-20

5.20 Blade Height Scale Adjustment

After the entire sawmill has been aligned and all adjustments made, check that the blade height scale indicates the true distance from the blade to the bed rails.

1. Move the saw head so the blade is positioned 14 3/4" (375 mm) above the bed rails by actual measurement with a rule.

See Figure 5-21.

2. View the blade height scale with eyes level with the indicator.

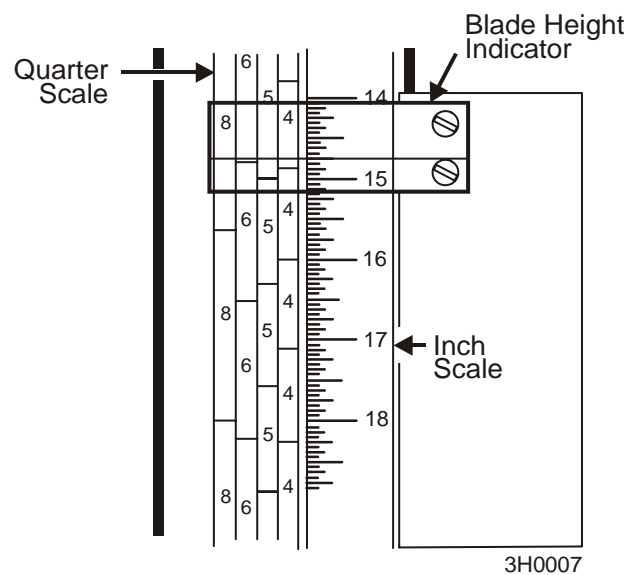

FIG. 5-21

3. Loosen the indicator bracket mounting bolts and adjust the bracket until the indicator is aligned with the 14 3/4" (375 mm) mark on the scale (+0 -1/32 [8 mm]).

A

alignment

- blade guide 5-14
- blade installation 5-3
- frame setup 5-2
- lower track rollers 5-7
- main bed rails 5-9
- pivot bed rails 5-23
- sawmill 5-1
- slide pad adjustment 5-5

B

battery

- troubleshooting problems 4-3

belt

- up/down tension 3-22

blade

- breakage, troubleshooting 4-1
- deflection 5-15
- installation 2-7
- tensioning 2-8
- tracking 2-9

blade guide

- horizontal tilt 5-19
- maintenance 3-2
- spacing 5-18
- vertical tilt 5-16

blade guide arm

- operation 2-21

brake strap

- tension 3-12

C

chain

- feed tension 3-20
- maintenance 3-9
- up/down tension 3-19

clamping logs 2-17

- clamp extension accessory 2-19

clutch/brake lever

- operation 2-22

H

hydraulic

- components 1-17
- control operation 2-12
- fluid level 3-14
- hoses 1-19
- schematic 1-15, 1-16
- troubleshooting problems 4-9

L

leveling logs 2-18

loading logs 2-16

O

operation

- edging 2-26
- sawing 2-25

INDEX

P

power feed
 mechanical troubleshooting test 4-15
 operation 2-24
 preliminary troubleshooting test 4-14
 speed adjustment 2-23
 troubleshooting problems 4-5

R

retrofits
 blade guide set screws 3-2
 fuse block 3-22

S

safety
 lockout procedure 1-7

saw head
 tilt 5-26

scale
 blade height adjustment 5-27
 blade height operation 2-28
 inch height 2-29
 quarter inch 2-30

setup
 portable sawmill 2-2
 sawmill for operation 2-6
 stationary sawmill 2-1

side supports
 horizontal adjustment 5-20
 vertical adjustment 5-21

sight gauge
 adjustment 5-25

switch
 power feed & up/down maintenance 3-8

T

tensioner
 maintenance 3-10

track
 maintenance 3-5

troubleshooting 4-1
 electrical problems 4-3
 hydraulic problems 4-9
 power feed problems 4-5
 sawing problems 4-1

turning logs 2-17

U

up/down
 operation 2-20
 sight gauge operation 2-27
 troubleshooting problems 4-3

W

water lube
 operation 2-31