

Wood-Mizer[®] Sawmill

Safety, Setup, Operation & Maintenance Manual

LT40 Super

rev. J7.20



Safety is our #1 concern! Read and understand all safety information and instructions before operating, setting up or maintaining this machine.

Form #533

MODELS EFFECTED:

LT40E25
LT40SE25

California
Proposition 65 Warning



WARNING: Breathing gas/diesel engine exhaust exposes you to chemicals known to the State of California to cause cancer and birth defects or other reproductive harm.

- Always start and operate the engine in a well-ventilated area.
- If in an enclosed area, vent the exhaust to the outside.
- Do not modify or tamper with the exhaust system.
- Do not idle the engine except as necessary.

For more information go to **www.P65warnings.ca.gov**.



WARNING: Drilling, sawing, sanding or machining wood products can expose you to wood dust, a substance known to the State of California to cause cancer. Avoid inhaling wood dust or use a dust mask or other safeguards for personal protection.

For more information go to **www.P65Warnings.ca.gov/wood**.

Active Patents assigned to Wood-Mizer, LLC

Wood-Mizer, LLC has received patents that protect our inventions which are a result of a dedication to research, innovation, development, and design. Learn more at: woodmizer.com/patents

©2023 Wood-Mizer LLC

Printed in the United States of America, all rights reserved. No part of this manual may be reproduced in any form by any photographic, electronic, mechanical or other means or used in any information storage and retrieval system without written permission from

Wood-Mizer, LLC
8180 West 10th Street
Indianapolis, Indiana 46214

Table of Contents

Section-Page

SECTION 1	INTRODUCTION	1-1
1.1	About This Manual.....	1-1
1.2	Getting Service.....	1-2
	<i>General Contact Information.....</i>	<i>1-2</i>
	<i>Wood-Mizer Locations.....</i>	<i>1-3</i>
1.3	Specifications	1-4
1.4	Customer and Sawmill Identification.....	1-5
SECTION 2	GENERAL SAFETY	2-1
2.1	Safety Symbols.....	2-1
2.2	Safety Instructions.....	2-1
2.3	Electrical Lockout Procedures.....	2-3
SECTION 2		2-4
2.1	Safety Instructions.....	2-5
2.2	Electrical Lockout Procedures.....	2-12
SECTION 3	SAWMILL SETUP	3-1
3.1	Stationary Sawmill Setup.....	3-1
3.2	Portable Sawmill Setup.....	3-3
3.3	Replacing The Blade.....	3-7
3.4	Tensioning The Blade.....	3-8
3.5	Tracking The Blade.....	3-9
3.6	Starting The Engine or Motor.....	3-10
3.7	Board Return	3-11
SECTION 4	SAWMILL OPERATION	4-1
4.1	Optional Hydraulic Log Loader/Turner Control Operation.....	4-1
4.2	Loading, Turning And Clamping Logs.....	4-4
4.3	Manual Up/Down Operation.....	4-7
4.4	Blade Guide Arm Operation.....	4-8
4.5	Clutch/Brake Operation.....	4-9
4.6	Power Feed Operation.....	4-11
4.7	Cutting The Log.....	4-13
4.8	Edging.....	4-14
4.9	Optional Cutting Procedure for Super Series Mills.....	4-15
4.10	Blade Height Scale.....	4-16
4.11	Water Lube Operation.....	4-18
4.12	Preparing The Sawmill For Towing.....	4-19
SECTION 5	MAINTENANCE	5-1
5.1	Wear Life.....	5-1
5.2	Blade Guides.....	5-2
5.3	Sawdust Removal.....	5-4
5.4	Carriage Track, Wiper, & Scraper.....	5-5
5.5	Vertical Mast Rails.....	5-7

Table of Contents

Section-Page

5.6	Drum Switches	5-8
5.7	Miscellaneous	5-9
5.8	Blade Tensioner.....	5-10
5.9	Blade Wheel Belts	5-12
5.10	Brake Strap Adjustment	5-13
5.11	Drive Belt Adjustment.....	5-14
	<i>Adjust the drive belt support</i>	<i>5-16</i>
5.12	Drive Bearing	5-18
5.13	Up/Down System.....	5-19
5.14	Power Feed	5-22
5.15	Charging the Battery.....	5-25
5.16	Hydraulic System (Optional Log Loader/Turner).....	5-27
5.17	Maintenance Chart.....	5-28
5.17	MAINTENANCE LOG	5-28
SECTION 6	TROUBLESHOOTING GUIDE	6-1
6.1	Sawing Problems	6-1
6.2	Electrical Problems.....	6-3
6.3	Circuit Breaker Operation	6-5
6.4	Power Feed Problems	6-6
6.5	Dual-Axis Motor Driver Module Troubleshooting	6-8
6.6	Power Feed Variable Feed Rate Switch Test	6-9
6.7	Power Feed Preliminary Test	6-10
6.8	Power Feed Mechanical Test.....	6-11
6.9	Hydraulic Problems (Optional Log Loader/Turner).....	6-12
6.10	Engine/Motor and Drive Pulleys Alignment.....	6-15

Table of Contents

Section-Page

SECTION 7 SAWMILL ALIGNMENT 7-1

7.1	Routine Alignment Procedure	7-1
7.2	Complete Alignment Procedure	7-14
	<i>Frame Setup</i>	7-14
	<i>Blade Installation</i>	7-14
	<i>Saw Head Slide Pad Adjustment</i>	7-14
	<i>Blade Wheel Alignment</i>	7-15
	<i>Track Roller Adjustment</i>	7-19
	<i>Bed Rail Adjustment</i>	7-21
	<i>Blade Guide Installation</i>	7-23
	<i>Blade Guide Arm Alignment</i>	7-25
	<i>Blade Guide Deflection</i>	7-29
	<i>Blade Guide Vertical Tilt Alignment</i>	7-29
	<i>Blade Guide Horizontal Tilt Adjustment</i>	7-31
	<i>Blade Guide Flange Spacing</i>	7-32
	<i>Blade Guide Level (Optional High-Performance blocks only)</i>	7-33
	<i>Blade Block Adjustment (Optional High-Performance blocks only)</i>	7-33
	<i>Side Support Alignment</i>	7-34
	<i>Clamp Stop/Stop Bolt Adjustment</i>	7-35
	<i>Saw Head Tilt</i>	7-35
	<i>Blade Height Scale Adjustment</i>	7-36
	<i>Board Return Bracket</i>	7-37

SECTION 8 HYDRAULIC INFORMATION (OPTIONAL LOADER/TURNER) 8-1

8.1	Hydraulic Schematic	8-1
8.2	Hydraulic Layout Diagram	8-2
8.3	Hydraulic Components.....	8-3
8.4	Hydraulic Hoses	8-4

INDEX I

California
Proposition 65 Warning



WARNING: Breathing gas/diesel engine exhaust exposes you to chemicals known to the State of California to cause cancer and birth defects or other reproductive harm.

- Always start and operate the engine in a well-ventilated area.
- If in an enclosed area, vent the exhaust to the outside.
- Do not modify or tamper with the exhaust system.
- Do not idle the engine except as necessary.

For more information go to **www.P65warnings.ca.gov**.



WARNING: Drilling, sawing, sanding or machining wood products can expose you to wood dust, a substance known to the State of California to cause cancer. Avoid inhaling wood dust or use a dust mask or other safeguards for personal protection.

For more information go to **www.P65Warnings.ca.gov/wood**.

Active Patents assigned to Wood-Mizer, LLC

Wood-Mizer, LLC has received patents that protect our inventions which are a result of a dedication to research, innovation, development, and design. Learn more at: woodmizer.com/patents

©2023 Wood-Mizer LLC

Printed in the United States of America, all rights reserved. No part of this manual may be reproduced in any form by any photographic, electronic, mechanical or other means or used in any information storage and retrieval system without written permission from

Wood-Mizer, LLC
8180 West 10th Street
Indianapolis, Indiana 46214

Table of Contents

Section-Page

SECTION 1	INTRODUCTION	1-1
1.1	About This Manual.....	1-1
1.2	Getting Service.....	1-2
	<i>General Contact Information.....</i>	<i>1-2</i>
	<i>Wood-Mizer Locations.....</i>	<i>1-3</i>
1.3	Specifications.....	1-4
1.4	Customer and Sawmill Identification.....	1-5
SECTION 2	GENERAL SAFETY	2-1
2.1	Safety Symbols.....	2-1
2.2	Safety Instructions.....	2-1
2.3	Electrical Lockout Procedures.....	2-3
SECTION 2		2-4
2.1	Safety Instructions.....	2-5
2.2	Electrical Lockout Procedures.....	2-12
SECTION 3	SAWMILL SETUP	3-1
3.1	Stationary Sawmill Setup.....	3-1
3.2	Portable Sawmill Setup.....	3-3
3.3	Replacing The Blade.....	3-7
3.4	Tensioning The Blade.....	3-8
3.5	Tracking The Blade.....	3-9
3.6	Starting The Engine or Motor.....	3-10
3.7	Board Return.....	3-11
SECTION 4	SAWMILL OPERATION	4-1
4.1	Optional Hydraulic Log Loader/Turner Control Operation.....	4-1
4.2	Loading, Turning And Clamping Logs.....	4-4
4.3	Manual Up/Down Operation.....	4-7
4.4	Blade Guide Arm Operation.....	4-8
4.5	Clutch/Brake Operation.....	4-9
4.6	Power Feed Operation.....	4-11
4.7	Cutting The Log.....	4-13
4.8	Edging.....	4-14
4.9	Optional Cutting Procedure for Super Series Mills.....	4-15
4.10	Blade Height Scale.....	4-16
4.11	Water Lube Operation.....	4-18
4.12	Preparing The Sawmill For Towing.....	4-19
SECTION 5	MAINTENANCE	5-1
5.1	Wear Life.....	5-1
5.2	Blade Guides.....	5-2
5.3	Sawdust Removal.....	5-4
5.4	Carriage Track, Wiper, & Scraper.....	5-5
5.5	Vertical Mast Rails.....	5-7

Table of Contents

Section-Page

5.6	Drum Switches	5-8
5.7	Miscellaneous	5-9
5.8	Blade Tensioner.....	5-10
5.9	Blade Wheel Belts	5-12
5.10	Brake Strap Adjustment	5-13
5.11	Drive Belt Adjustment.....	5-14
	<i>Adjust the drive belt support</i>	<i>5-16</i>
5.12	Drive Bearing	5-18
5.13	Up/Down System.....	5-19
5.14	Power Feed	5-22
5.15	Charging the Battery.....	5-25
5.16	Hydraulic System (Optional Log Loader/Turner).....	5-27
5.17	Maintenance Chart.....	5-28
5.17	MAINTENANCE LOG	5-28
SECTION 6	TROUBLESHOOTING GUIDE	6-1
6.1	Sawing Problems	6-1
6.2	Electrical Problems.....	6-3
6.3	Circuit Breaker Operation	6-5
6.4	Power Feed Problems	6-6
6.5	Dual-Axis Motor Driver Module Troubleshooting	6-8
6.6	Power Feed Variable Feed Rate Switch Test	6-9
6.7	Power Feed Preliminary Test	6-10
6.8	Power Feed Mechanical Test.....	6-11
6.9	Hydraulic Problems (Optional Log Loader/Turner).....	6-12
6.10	Engine/Motor and Drive Pulleys Alignment.....	6-15

Table of Contents

Section-Page

SECTION 7 SAWMILL ALIGNMENT 7-1

7.1	Routine Alignment Procedure	7-1
7.2	Complete Alignment Procedure	7-14
	<i>Frame Setup</i>	7-14
	<i>Blade Installation</i>	7-14
	<i>Saw Head Slide Pad Adjustment</i>	7-14
	<i>Blade Wheel Alignment</i>	7-15
	<i>Track Roller Adjustment</i>	7-19
	<i>Bed Rail Adjustment</i>	7-21
	<i>Blade Guide Installation</i>	7-23
	<i>Blade Guide Arm Alignment</i>	7-25
	<i>Blade Guide Deflection</i>	7-29
	<i>Blade Guide Vertical Tilt Alignment</i>	7-29
	<i>Blade Guide Horizontal Tilt Adjustment</i>	7-31
	<i>Blade Guide Flange Spacing</i>	7-32
	<i>Blade Guide Level (Optional High-Performance blocks only)</i>	7-33
	<i>Blade Block Adjustment (Optional High-Performance blocks only)</i>	7-33
	<i>Side Support Alignment</i>	7-34
	<i>Clamp Stop/Stop Bolt Adjustment</i>	7-35
	<i>Saw Head Tilt</i>	7-35
	<i>Blade Height Scale Adjustment</i>	7-36
	<i>Board Return Bracket</i>	7-37

SECTION 8 HYDRAULIC INFORMATION (OPTIONAL LOADER/TURNER) 8-1

8.1	Hydraulic Schematic	8-1
8.2	Hydraulic Layout Diagram	8-2
8.3	Hydraulic Components.....	8-3
8.4	Hydraulic Hoses	8-4

INDEX I

SECTION 1 INTRODUCTION**1.1 About This Manual**

This manual is to replace or to be used with all previous information received on the Wood-Mizer® sawmill. All future mailings will be an addition to or a revision of individual sections of this manual as we obtain new information.

The information and instructions given in this manual do not amend or extend the limited warranties for the equipment given at the time of purchase.

For general information regarding Wood-Mizer and our “Forest to Final Form” products, please refer to the All Products Catalog in your support package.

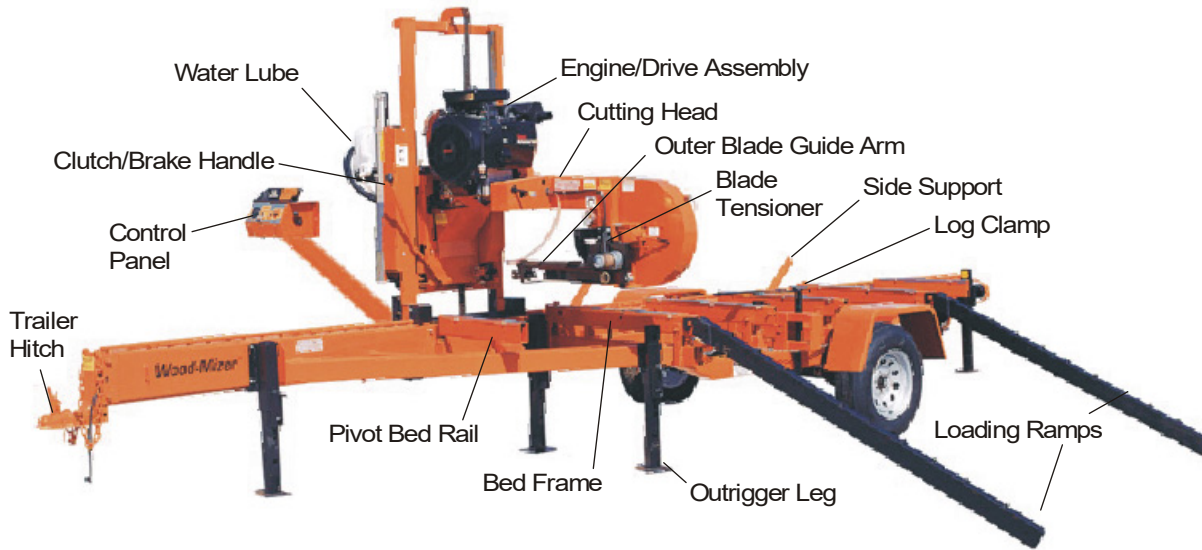

300001

MILL COMPONENTS

*.Wood-Mizer® is a registered trademark of Wood-Mizer LLC.

1.2 Getting Service

Wood-Mizer is committed to providing you with the latest technology, best quality and strongest customer service available on the market today. We continually evaluate our customers' needs to ensure we're meeting current wood-processing demands. Your comments and suggestions are welcome.

General Contact Information

Toll free phone numbers are listed below for the *continental* U.S. and Canada. See the next page for contact information for more Wood-Mizer locations.

	United States	Canada
Sales	1-800-553-0182	1-877-866-0667
Service	1-800-525-8100	1-877-866-0667
Website	www.woodmizer.com	www.woodmizer.ca
E-mail	woodmizer@woodmizer.com	oninfo@woodmizer.com

Office Hours: All times are Eastern Standard Time.

Monday - Friday	Indianapolis Office ONLY Saturday	Sunday
8 a.m. to 5 p.m.	8 a.m. to 12 p.m.	Closed

Please have your vehicle identification number and your customer number ready when you call.

Wood-Mizer will accept these methods of payment:

- Visa, Mastercard, or Discover
- COD
- Prepayment
- Net 15 (with approved credit)

Be aware that shipping and handling charges may apply. Handling charges are based on size and quantity of order. In most cases, items will ship on the day they are ordered. Second Day and Next Day shipping are available at additional cost.

If your sawmill was purchased outside the United States or Canada, contact the distributor for service.

Wood-Mizer Locations**USA World Headquarters*****Serving North & South America, Oceania, East Asia***

Wood-Mizer LLC
8180 West 10th Street
Indianapolis, IN 46214

Phone: 317.271.1542 or 800.553.0182
Customer Service: 800.525.8100
Fax: 317.273.1011
Email: infocenter@woodmizer.com

Canadian Headquarters***Serving Canada***

Wood-Mizer Canada
396 County Road 36, Unit B
Lindsay, ON K9V 4R3

Phone: 705.878.5255 or 877.357.3373
Fax: 705.878.5355
Email: ContactCanada@woodmizer.com

Brazilian Headquarters***Serving Brazil***

Wood-Mizer do Brasil
Rua Dom Pedro 1, No: 205 Bairro: Sao Jose
Ivoti/RS CEP:93.900-000

Tel: +55 51 9894-6461/ +55 21 8030-3338/ +55 51
3563-4784
Email: info@woodmizer.com.br

European Headquarters***Serving Europe, Africa, West Asia***

Wood-Mizer Industries Sp z o.o.
Nagorna 114
62-600 Kolo, Poland

Phone: +48.63.26.26.000
Fax: +48.63.27.22.327

Branches & Authorized Sales Centers

For a complete list of dealers, visit www.woodmizer.com

1.3 Specifications

Model: LT40 Super Rev. J5.03+				
Dimensions:		Metric	Wide Saw Head Only:	
	Length: 26'-4"	8.02m	26'-4"	
	Width: 6'-6"	1.97m	7'-1/2"	
	Height (Ground To Mast): 7'-5"	2.26m	7'-5"	
	Height (Max Head Position): 9'-10"	3m	9'-10"	
	Bed Height (Ground To Bed): 30 3/4"	0.78m	30 3/4"	
	Blade Length: 158"	4.01m	171"	
Weights:	Basic Unit with Trailer(with heaviest power option):			
	Tongue Weight:			
Trailer:	Axle Capacity: 3500 lbs	1587kg		
	Tire Capacity: 1870 lbs	848.2kg		
	Tire Size: ST215/75R14			
Cutting Capacity:			Wide Saw Head Only:	
	Length: 21'	6.4m	21'	
	Diameter: 36"	0.91m	36"	
	Maximum Log Weight: 4400 lbs	1995kg	4400 lbs	
	Max Clamp Width (from stop block): 26"	0.66m	26"	
	Max Throat Width (guide to guide): 27 1/2"	0.7m	34"	
	Max Cant Width (outer guide to stop block): 24 3/4"	0.63m	31 1/4"	
	Min. Cut Height: 1"	25.4mm	1"	
	Max. Cut Height: 35 1/4"	0.9m	35 1/4"	
	Maximum Throat Depth: 11 1/4"	0.28m	11 1/4"	
Power Unit:	G38	D35	D47	E25
	Manufacturer: Kohler	Yanmar	Yanmar	Lincoln
	Fuel: gas	Diesel	Diesel	Electric
	Horsepower Rating*: 35	35	47.5	25
	Weight (lbs)*: 132	345	400	
	Cooling System*: air	water	water	air
	Noise Level (dba)*: 100-105(@3000 rpm)	89	89	
	Engine Oil & Type*:			
	Engine Oil Capacity w/Filter*:			
	Temperature Range & Oil Grades*:			
	Coolant Capacity*:			
Rates:	Max. Forward (Not Cutting): 200 ft/min			
	Reverse: 215 ft/min			
	Hourly Production (Average range w/experienced operators/average size logs): 675 bd ft/hr			

*Manufacturer's specification

1.4 Customer and Sawmill Identification

Each Wood-Mizer sawmill has a model number and a 17-digit Vehicle Identification Number (VIN). In addition, when you pick up your mill, you will receive a customer number. These three numbers will help expedite our service to you. Please locate them now and write them below so you have quick, easy access to them. See the following figures for model number and V.I.N. descriptions.

(To be filled in by purchaser)

Mill Model _____
 Mill VIN _____
 Customer No _____

See below for a description of the V.I.N.

Basic model **LT40** Engine **E25** Revision number **A1** Minor revision level **.01**

VIN Plate Serial number Full revision number

MFG BY/FABRIQUÉ PAR: WOOD-MIZER, LLC 8180 W. 10th St. Indianapolis, IN
 46214-2400 U.S.A. 317/271-1542 Or 800/553-0182

VIN/NIV: **456D9271XSND A1017** **A1.01** **DATE:** **04/15/2017**

GVWR/PNBV: GAWR/PNBE: TIRE SIZE/PNEU: RIM /JANTE: COLD INFL. PRESSURE/ PRESS. DE GONF. À FROID:	VEHICLE TYPE/TYPE DE VÉHICULE: TRAILER/REMORQUE THIS VEHICLE CONFORMS TO ALL APPLICABLE FEDERAL MOTOR SAFETY STANDARDS AND THOSE PRESCRIBED UNDER THE CANADIAN VEHICLE SAFETY REGULATIONS IN EFFECT ON THE DATE OF MANUFACTURE. CE VÉHICULE EST CONFORME À TOUTES LES NORMES QUI LUI SONT APPLICABLES EN VERTU DU REGLEMENT SUR LA SÉCURITÉ DES VÉHICULES AUTOMOBILES DU CANADA EN VIGUEUR À LA DATE DE SA FABRICATION.
--	---

One or more patents may apply: U.S. Patent #6,655,429

	Company Identification Number	Weight Class	Product Designation number	Length of the Trailer	Axle count	Check Digit	Year of Manufacture (coded)	Manufacture location	Month of Manufacture	Revision Level	Sequence Number
Sample VIN	456	D	9	27	1	X	S	N	D	A1	017

V.I.N. DESCRIPTION

Wood-Mizer® LLC
Limited Product Warranty



Wood-Mizer LLC (“Warrantor”), an Indiana corporation with its principal place of business at 8180 West Tenth Street, Indianapolis, IN 46214-2400 USA, warrants to the purchaser (“Purchaser”) that for the time periods specifically stated herein and subject to the terms, conditions and limitations stated herein, the equipment manufactured by the Warrantor will be free from defects in material and workmanship attributable to Warrantor so long as, during the warranty periods stated herein, the equipment is installed, operated and maintained in accordance with the instructions provided by Warrantor.

PRODUCT	MODEL CLASS	LENGTH OF WARRANTY		EFFECTIVE DATE
		USA & CANADA	NON USA & CANADA	
Portable Sawmills, Resaws, Edgers	LT, LX, HR, EG	Two years	One year	Date of purchase
Portable Sawmills with Chassis	LT28, LT35, LT40, LT50, LT70, LX450	Two years, excluding the chassis, which chassis shall have a five year warranty	One year	
Industrial Sawmills, Resaws, Edgers	WM, HR, EG, TVS, SVS	One year	One year	Date of purchase or date of installation / training (if applicable), whichever occurs first, not to exceed 6 months from date of purchase
TITAN Industrial	WB, TV, HR, EG, EA, MR	One year	One year	
Material Handling	TWC, IC, TD, LD, GC, CR, CB, CC	One year	One year	
Blade Maintenance Equipment	BMS, BMT, BMST	One year	One year	Date of purchase
Options and Accessories	Various	One year*	One year*	
Moulders, Extractors, Kilns	MP, MD, KS, KD	One year	One year	
Slab Flatteners	MB	Two years	One year	
Pallet Equipment	PD, PC	One year	One year	
Log Splitters	FS	One year	One year	
Replacement Parts	Various	90 days	90 days	

* Warranty on Options will match the warranty on the primary equipment when purchased on same invoice.

Exclusions from 90 Day, Limited One Year and Two Year Warranty

Warrantor shall have no responsibility under this warranty for any wear components, including, but not limited to: belts, blade guides, blades, electric motor brushes, drum switches, filters, fuses, hoses, bearings (excluding cylindrical drive bearings), bushings, cable carriers, and spark plugs. All wear components are furnished “as is”, without any warranty from Warrantor. This limited warranty does not cover any defects caused by misuse, negligence, alterations, damage due to overload, abnormal conditions, excessive operation, accident, or lack of performance of normal maintenance services.

Several components which are used in the manufacture of the equipment but not manufactured by Warrantor such as cant hooks, power plants, laser sights, batteries, tires, and trailer axles have warranties provided by the original equipment manufacturer (written copies available upon request). Warrantor does not separately warrant such items. Components or equipment manufactured by third parties are not covered by this warranty. Warrantor, however, will provide reasonable assistance to the Purchaser to make claims against any warranties applicable to such component parts as provided by such original equipment manufacturers. Components or equipment manufactured by third parties are not covered by this Warranty.

Five Year Limited Chassis Warranty

The limited five year chassis warranty described above, DOES NOT extend to (a) any damage stemming from accident, improper towing, overload, abuse, misuse, abnormal conditions, negligence, excessive operation, or lack of maintenance, (b) rust caused by exposure to corrosive atmospheric conditions, or (c) the sawmill head, carriage, axle, brakes, or any hydraulic or electrical components attached to the chassis.

Warrantor’s Obligations as To Defects

In the event that the equipment fails to perform due to defective materials or workmanship attributable to Warrantor under normal use and service within the established warranty period, Purchaser’s sole and exclusive remedy and Warrantor’s sole liability shall be to replace or repair, in Warrantor’s sole and subjective discretion, any defective part at Warrantor’s principal place of business without cost to the Purchaser if such defect exists. The determination of whether a product is defective shall be made by Warrantor in Warrantor’s sole and subjective discretion. The Purchaser must notify Warrantor prior to shipping any defective part. Warrantor, at its sole discretion, may cover expenses incurred in shipping the defective part to Warrantor for evaluation; provided, however, that Warrantor will not be responsible for labor, travel time, mileage, removal, installation or incidental or consequential damages. However, any part in excess of 140 pounds must be returned by the Purchaser, to the Warrantor’s nearest authorized facility at the Purchaser’s expense, if return is requested by Warrantor. Warrantor shall have a reasonable time within which to replace or repair the defective part. If Warrantor determines that the product is not defective under the terms of this warranty in Warrantor’s sole and subjective discretion, then Purchaser shall be responsible for any expenses incurred by Warrantor in returning the equipment to the Purchaser.

Limitations and Disclaimers of Other Warranties

EXCEPT FOR THE EXPRESS WARRANTY PROVISIONS STATED ABOVE, WARRANTOR DISCLAIMS ALL WARRANTIES, EXPRESS AND/OR IMPLIED, INCLUDING WITHOUT LIMITATION, THE IMPLIED WARRANTIES OF MERCHANTABILITY, AND FITNESS FOR A PARTICULAR PURPOSE, NONINFRINGEMENT AND TITLE. No representation or other affirmation of fact by representatives of Warrantor, whether verbal or in writing, including photographs, brochures, samples, models, or other sales aids, shall constitute a warranty or other basis for any legal action against Warrantor. There are no other representations, promises, agreements, covenants, warranties, guarantees, stipulations or conditions, express or implied, by Warrantor except as expressly set forth herein. THE ORIGINAL PURCHASER AND ANY INTENDED USER OR BENEFICIARY OF THIS EQUIPMENT, SHALL NOT BE ENTITLED TO RECOVER ANY INDIRECT, SPECIAL, PUNITIVE, EXEMPLARY, CONSEQUENTIAL, SPECIAL, OR INCIDENTAL DAMAGES OR LOSSES, INCLUDING BUT NOT LIMITED TO, DAMAGES OF LOST PRODUCTION, LOST REVENUE, LOST PRODUCT, LOST PROFITS, LOST BUSINESS, LOSS OF USE, LOSS OF GOODWILL, OR BUSINESS INTERRUPTION, FROM WARRANTOR FOR ANY REASON WHATSOEVER INCLUDING WITHOUT LIMITATION WARRANTY OR DEFECT IN THE PRODUCT REGARDLESS OF THE SOLE, JOINT AND/OR CONCURRENT NEGLIGENCE, BREACH OF CONTRACT, BREACH OF WARRANTY, STRICT LIABILITY IN TORT OR STATUTORY CLAIMS OR OTHER LEGAL FAULT OR RESPONSIBILITY OF EITHER WARRANTOR OR PURCHASER OR ITS EMPLOYEES OR AGENTS. Warrantor does not warrant that its equipment meets or complies with the requirements of any particular safety code or governmental requirements.

Defective items replaced under the terms of this warranty become the property of Warrantor.

Design Changes

Warrantor reserves the right to change the design of its products from time to time without notice and without obligation to make corresponding changes in or to its products previously manufactured.

Rights of Purchasers

The validity and effect of this limited warranty as well as its interpretation, operation and effect, shall be determined exclusively by the principles of law and equity of the State of Indiana, USA. This limited warranty gives Purchaser specific legal rights. Purchaser may also have other rights, which may vary from state to state. Some states may not allow limitations as to the duration of implied warranties or to the exclusion or limitation of incidental or consequential damages, so some of the limitations and exclusions detailed set forth above may not apply. In the event that any one or more of the provisions of this warranty shall be or become invalid, illegal or unenforceable in any respect, the validity, legality and enforceability of the remaining provisions of this warranty shall not be affected thereby.

Interpretations

This Warranty constitutes the entire warranty agreement between Warrantor and Purchaser and supersedes any prior understandings or agreements pertaining to the same subject matter. This warranty cannot be amended except in writing which refers to this warranty which is signed by both Warrantor and Purchaser.

SECTION 2 GENERAL SAFETY

2.1 Safety Symbols

The following symbols and signal words call your attention to instructions concerning your personal safety. Be sure to observe and follow these instructions.

 **DANGER!** indicates an imminently hazardous situation which, if not avoided, will result in serious injury or death.

 **WARNING!** suggests a potentially hazardous situation which, if not avoided, could result in serious injury or death.

 **CAUTION!** refers to potentially hazardous situations which, if not avoided, may result in minor or moderate injury or damage to equipment.

NOTICE indicates vital information.

2.2 Safety Instructions

OWNER/OPERATOR'S RESPONSIBILITY

The procedures listed in this manual may not include all ANSI, OSHA, or locally required safety procedures. **It is the owner/operator's responsibility and not Wood-Mizer LLC to ensure all operators are properly trained and informed of all safety protocols.**

Owner/Operators are responsible for following all safety procedures when operating and performing maintenance to the equipment.

OBSERVE ALL SAFETY INSTRUCTIONS

NOTICE Read the entire Operator's Manual before operating this equipment.

Note all safety warnings throughout this manual and those posted on the machine.

Be able to access this manual at all times while operating this equipment.

Read additional manufacturer's manuals and observe their applicable safety instructions.

Only persons who have read and understood the entire operator's manual should operate this equipment.

This equipment is not intended for use by or around children.

It is the owner/operator's responsibility to comply with all applicable federal, state, and local laws, rules, and regulations regarding the ownership, operation, and transporting your equipment.

Operators should become thoroughly familiar with and comply with these applicable laws for operating and transporting equipment.

 **WARNING!** Clean sawdust from all guards, vents, control boxes, or any area where saw-

dust may gather **after every shift**. Failure to do so may result in fire, causing death or serious injury.

WEAR SAFETY CLOTHING

 **WARNING!** Secure all loose clothing and jewelry before operating the equipment.

Always wear eye, ear, and foot protection when operating or servicing the equipment.

Wear hand protection while servicing the equipment blades.

Wear respiratory protection when sawing woods that require it. (It is up to the sawyer to know which woods require respiratory protection.)

HANDLE FUEL/LUBRICANTS SAFELY

 **DANGER!** Due to the flammable nature of fuel and oil, never smoke, weld, grind or allow sparks near your engine or storage tanks, especially during times of fueling.

Do not allow fuel to spill on a hot engine during fueling operations or otherwise.

 **WARNING!** Store gasoline away from sawdust and other flammable materials.

Do not use flammable fuels or liquids such as diesel fuel. Use **ONLY** water and Wood-Mizer Lube Additive with the water lube accessory.

EQUIPMENT SETUP

 **DANGER!** Do not operate the equipment without **all** covers and guards in place.

 **WARNING!** Set up the equipment on solid, level ground.

Keep all persons out of the area between the frame rails while loading and unloading the equipment.

CHECK EQUIPMENT BEFORE OPERATION

 **DANGER!** Ensure all guards and covers are in place and secured before operating or towing the equipment.

Use the safety retainer pin and cable to fasten blade housing covers.

 **WARNING!** Do not operate the equipment without the bed end retaining brackets properly installed; the saw head may fall from the log bed.

KEEP PERSONS AWAY

 **DANGER!** Keep all persons out of the path of moving equipment and logs when operating equipment or loading and turning logs.

Ensure the blade is disengaged and all persons are out of the path of the blade before starting the engine or motor.

KEEP HANDS AWAY

 **DANGER!** Remove power before clearing debris or any other maintenance activity.

Disengage the blade and shut off the equipment engine before changing the blade.

 **WARNING!** Avoid contact with any hot parts (motors).

Allow the system to cool sufficiently before beginning any service function, including debris removal.

Avoid contact with sharp edges of the cutting blades.

Stay a safe distance from rotating members (shafts, pulleys, fans, etc.) and ensure loose clothing or long hair does not engage rotating members

Do not spin the blade wheels by hand. Spinning the blade wheels by hand may result in serious injury.

Disengage the clutch/brake mechanism whenever the equipment is not cutting.

Do not adjust the engine drive belt with the engine running.

Keep hands, feet, etc., clear of exiting sawdust chute when operating equipment.

UP/DOWN SYSTEM SAFETY

 **WARNING!** Secure the saw head with a chain with a minimum of 1900 lbs. working load capacity before adjusting the up/down chain.

Release pressure from the up/down assist prior to performing any service to the assembly. Parts are under tension and may fly apart.

Do not disassemble the pressurized cylinder. Parts are under pressure and may fly apart or damage the cylinder.

KEEP SAFETY LABELS IN GOOD CONDITION

NOTICE Ensure that all safety decals are clean and readable. Replace all damaged safety decals to prevent personal injury or damage to the equipment. Contact your local

distributor, or call your Customer Service Representative to order more decals.

NOTICE If replacing a component that has a safety decal affixed to it, ensure the new component also has the safety decal affixed in the same place.

KEEP MILL AND AREA AROUND MILL CLEAN

 **WARNING!** Maintain a clean and clear path for all necessary movement around the mill and material stacking areas.

Do not allow children in the area of the mill.

GAS OR DIESEL ENGINE OPERATION

 **DANGER!** Operate your engine/machine only in well ventilated areas.

Do not operate an engine with a fuel or oil leak.

 **WARNING!** Do not operate engine without proper and operational spark arrester/muffler.

DISPOSE OF WOOD BY-PRODUCTS PROPERLY

NOTICE Properly dispose of all wood by-products, including sawdust, chips, and other debris, including operation waste such as oil, filters, etc.

WORKING WITH BATTERIES

 **DANGER!** Batteries expel explosive gases; keep sparks, flames, burning cigarettes, or other ignition sources away at all times.

 **WARNING!** Always wear safety goggles and a face shield when working near batteries.

Wash hands after handling batteries to remove possible lead, acid, or other contaminants.

Charge the battery in a well ventilated area.

Do not attempt to charge a frozen battery.

 **CAUTION!** Do not overcharge the battery. Overcharging may reduce the overall service life of the battery.

Ensure the battery is fully charged before transporting the equipment. If the battery is not fully charged, excessive vibration could reduce the overall service life of the battery.

NOTICE When working with batteries, use extreme care to avoid spilling or splashing electrolyte (dilute sulfuric acid) as it can destroy clothing and burn the skin.

EMERGENCY TREATMENT FOR CONTACT WITH BATTERY COMPONENTS (LEAD/SULFURIC ACID) per SDS (Safety Data Sheet):

EYE CONTACT	Sulfuric Acid and Lead: Flush eyes immediately with large amounts of water for at least 15 minutes while lifting lids. Seek immediate medical attention.
SKIN CONTACT	Sulfuric Acid: Flush affected area(s) with large amounts of water using deluge emergency shower, if available, shower for at least 15 minutes. Remove contaminated clothing, including shoes. If symptoms persist, seek medical attention. Wash contaminated clothing before reuse. Discard contaminated shoes. Lead: Wash immediately with soap and water.
INGESTION	Sulfuric Acid: Administer large amounts of water. Do NOT induce vomiting or aspiration into the lungs may occur and can cause permanent injury or death; consult physician.
INHALATION	Sulfuric Acid: Remove to fresh air immediately. If not breathing, give artificial respiration. If breathing is difficult, give oxygen. Consult a physician. Lead: Remove from exposure, gargle, wash nose and lips; consult physician.

2.3 Electrical Lockout Procedures

RULES FOR USING LOCKOUT PROCEDURE

The equipment shall be locked out to protect against accidental or inadvertent operation when such operation could cause injury to personnel. Do not attempt to operate any switch or valve bearing a lock.

LOCKOUT PROCEDURES MUST BE USED DURING, BUT NOT LIMITED TO:

- Changing or adjusting blades
- Unjamming operations
- Cleaning
- Mechanical repair
- Electrical maintenance
- Retrieval of tools/parts from work area
- Activities where guards or electrical panel guard is open or removed

MAINTENANCE HAZARDS INCLUDE, BUT NOT LIMITED TO:

- Blade contact
- Pinch points
- Kickbacks
- Missiles (thrown blades/wood chips)
- Electrical

FAILURE TO LOCKOUT MAY RESULT IN, BUT NOT LIMITED TO:

- Cut
- Crush

- Blindness
- Puncture
- Electrocutation
- Serious injury and death
- Amputation
- Burn
- Shock

TO CONTROL MAINTENANCE DANGERS:

- Lockout procedures must be followed (see **OSHA regulation 1910.147**).
- Never rely on machine stop control for maintenance safety (emergency stops, on/off buttons, interlocks).
- Do not reach into moving blades or feed systems. Allow all coasting parts to come to a complete stop.
- Electrical power supply and air supply must both be locked out.
- Where established lockout procedures cannot be used (electrical troubleshooting or mechanical dynamic troubleshooting), alternative effective protective techniques shall be employed which may require special skills and planning.
- Always follow safe operations practices in the workplace.

EQUIPMENT LOCKOUT PROCEDURE

Lockout procedures per OSHA regulation 1910.147, appendix A:

GENERAL

The following simple lockout procedure is provided to assist owner/operators in developing their procedures so they meet the requirements of **OSHA regulation 1910.147**. When the energy isolating devices are not lockable, tagout may be used, provided the owner/operator complies with the provisions of the standard which require additional training and more rigorous periodic inspections. When tagout is used and the energy isolating devices are lockable, the owner/operator must provide full operator protection (see OSHA regulation 1910.147, paragraph (c)(3)) and additional training and more rigorous periodic inspections are required. For more complex systems, more comprehensive procedures may need to be developed, documented, and utilized.

PURPOSE

This procedure establishes the minimum requirements for the lockout of energy isolating devices whenever maintenance or servicing is done on machines or equipment. It shall be used to ensure that the machine or equipment is stopped, isolated from all potentially hazardous energy sources and locked out before personnel perform any servicing or maintenance where the unexpected energization or start-up of the machine or equipment or release of stored energy could cause injury.

COMPLIANCE WITH THIS PROGRAM

All personnel are required to comply with the restrictions and limitations imposed upon them during the use of lockout. The authorized personnel are required to perform the lockout in accordance with this procedure. All operators,

upon observing a machine or piece of equipment which is locked out to perform servicing or maintenance shall not attempt to start, energize, or use that machine or equipment.

SEQUENCE OF LOCKOUT

1. Notify all affected personnel that servicing or maintenance is required on a machine or equipment and that the machine or equipment must be shut down and locked out to perform the servicing or maintenance.
2. The authorized employee shall refer to the company procedure to identify the type and magnitude of the energy that the machine or equipment utilizes, shall understand the hazards of the energy, and shall know the methods to control the energy.
3. If the machine or equipment is operating, shut it down by the normal stopping procedure (depress the stop button, open switch, close valve, etc.).
4. De-activate the energy isolating device(s) so that the machine or equipment is isolated from the energy source(s).
5. Lock out the energy isolating device(s) with assigned individual lock(s).
6. Stored or residual energy (such as that in capacitors, springs, elevated machine members, rotating fly-wheels, hydraulic systems, and air, gas, steam, or water pressure, etc.) must be dissipated or restrained by methods such as grounding, repositioning, blocking, bleeding down, etc.
7. Ensure that the equipment is disconnected from the energy source(s) by first checking that no personnel are exposed, then verify the isolation of the equipment by operating the push button or other normal operat-

SECTION 2

ing control(s) or by testing to make certain the equipment will not operate.



CAUTION! Return operating control(s) to neutral or "off" position after verifying the isolation of the equipment.

8. The machine or equipment is now locked out.

RESTORING EQUIPMENT TO SERVICE

When the servicing or maintenance is completed and the machine or equipment is ready to return to normal operating condition, the following steps shall be taken.

1. Check the machine or equipment and the immediate area around the machine to ensure that nonessential items have been removed and that the machine or equipment components are operationally intact.
2. Check the work area to ensure that all personnel have been safely positioned or removed from the area.
3. Verify that the controls are in neutral.
4. Remove the lockout devices and re-energize the machine or equipment.

NOTE: The removal of some forms of blocking may require re-energization of the machine before safe removal.

5. Notify affected personnel that the servicing or maintenance is completed and the machine or equipment is ready for use.

PROCEDURE INVOLVING MORE THAN ONE PERSON

In the preceding steps, if more than one individual is required to lock out the equipment, **each shall place his own personal lock on the energy isolating devices.**

2.1 Safety Instructions

OWNER'S RESPONSIBILITY

The procedures listed in this manual may not include all ANSI, OSHA, or locally required safety procedures. It is the owner/operator's responsibility and not Wood-Mizer Products to ensure all operators are properly trained and informed of all safety protocols. Owner/Operators are responsible for following all safety procedures when operating and performing maintenance to the sawmill.

NOTE: ONLY safety instructions regarding personal injury are listed in this section. Caution statements regarding only equipment damage appear where applicable throughout the manual.



WARNING! Clean sawdust from all guards, vents, control boxes, or any area where sawdust may gather **after every shift**. Failure to do so may result in fire, causing death or serious injury.

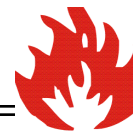

OBSERVE SAFETY INSTRUCTIONS



IMPORTANT! Read the entire Operator's Manual before operating the sawmill. Take notice of all safety warnings throughout this manual and those posted on the machine. Keep this manual with this machine at all times, regardless of ownership.

Also read any additional manufacturer's manuals and observe any applicable safety instructions including dangers, warnings, and cautions.

Only persons who have read and understood the entire operator's manual should operate the sawmill. The sawmill is not intended for use by or around children.



IMPORTANT! It is always the owner's responsibility to comply with all applicable federal, state and local laws, rules and regulations regarding the ownership, operation and towing of your Wood-Mizer sawmill. All Wood-Mizer mill owners are encouraged to become thoroughly familiar with these applicable laws and comply with them fully while using or towing the mill.



WEAR SAFETY CLOTHING



WARNING! Secure all loose clothing, hair, and jewelry before operating the sawmill. Failure to follow this may result in serious injury or death.



WARNING! Always wear gloves and eye protection when handling bandsaw blades. Changing blades is safest when done by one person! Keep all other persons away from area when coiling, carrying or changing a blade. Failure to follow this may result in serious injury or death.





WARNING! Always wear eye, ear, and foot protection when operating or servicing the sawmill.



WARNING! Some woods require respiration protection when operating the sawmill. It is the sawyer's responsibility to know which woods require respiration protection.

KEEP SAWMILL AND AREA AROUND SAWMILL CLEAN



DANGER! Maintain a clean and clear path for all necessary movement around the mill and lumber stacking areas. Failure to follow this will result in serious injury or death.

HANDLE FUEL/LUBRICANTS SAFELY



DANGER! Do not smoke, weld, grind or allow sparks near your engine or storage tanks, especially during times of fueling. Failure to follow this will result in serious injury or death.



DANGER! Never allow fuel to spill on a hot engine during fueling operations or otherwise. The hot temperature of your engine could induce a fire or explosion. Failure to follow this will result in serious injury or death.



WARNING! Store gasoline away from sawdust and other flammable materials. Failure to follow this may result in serious injury or death.



WARNING! Use ONLY water and Wood-Mizer Lube Additive with the water lube accessory. Never use flammable fuels or liquids such as diesel fuel. If these types of liquids are necessary to clean the blade, remove it and clean with a rag. Failure to follow this could result in serious injury or death.



WARNING! Drum switch grease contains Petroleum Hydrocarbon Lubricant. Eye and skin irritant. If introduced into eyes, flush with water for at least 15 minutes. If film or irritation persists, seek medical attention. Wash skin with soap and water. If ingested, do not induce vomiting - contact a physician. KEEP OUT OF THE REACH OF CHILDREN.

DISPOSE OF SAWING BY-PRODUCTS PROPERLY



IMPORTANT! Always properly dispose of all sawing by-products, including sawdust and other debris, coolant, oil, fuel, oil filters and fuel filters.





USE CAUTION WHEN WORKING WITH BATTERIES (ENGINES ONLY)



DANGER! Batteries expel explosive gases; keep sparks, flames, burning cigarettes, or other ignition sources away at all times. Failure to follow this will result in serious injury or death.





WARNING! Always wear safety goggles and a face shield when working near batteries. Failure to follow this could result in serious injury or death.

-  **WARNING!** Wash hands after handling batteries to remove possible lead, acid, or other contaminants. Failure to follow this could result in serious injury or death.
-  **WARNING!** Charge the battery in a well ventilated area. Failure to follow this could result in serious injury or death.
-  **WARNING!** Do not attempt to charge a frozen battery. Failure to follow this could result in serious injury or death.
-  **IMPORTANT!** When working with batteries, use extreme care to avoid spilling or splashing electrolyte (dilute sulfuric acid) as it can destroy clothing and burn the skin.

EMERGENCY TREATMENT FOR CONTACT WITH BATTERY COMPONENTS (LEAD/SULFURIC ACID) per SDS (Safety Data Sheet):





EYE CONTACT	Sulfuric Acid and Lead: Flush eyes immediately with large amounts of water for at least 15 minutes while lifting lids. Seek immediate medical attention if eyes have been exposed directly to acid.
SKIN CONTACT	Sulfuric Acid: Flush affected area(s) with large amounts of water using deluge emergency shower, if available, shower for at least 15 minutes. Remove contaminated clothing, including shoes. If symptoms persist, seek medical attention. Wash contaminated clothing before reuse. Discard contaminated shoes. Lead: Wash immediately with soap and water.
INGESTION	Sulfuric Acid: Administer large amounts of water. Do NOT induce vomiting or aspiration into the lungs may occur and can cause permanent injury or death; consult physician.
INHALATION	Sulfuric Acid: Remove to fresh air immediately. If not breathing, give artificial respiration. If breathing is difficult, give oxygen. Consult a physician. Lead: Remove from exposure, gargle, wash nose and lips; consult physician.

-  **CAUTION!** Do not overcharge the battery. Overcharging could reduce the overall service life of the battery.
-  **CAUTION!** Be sure the battery is fully charged before transporting the sawmill. If the battery is not fully charged, excessive vibration could reduce the overall service life of the battery.



CAUTIONS FOR SAWMILL SETUP

-  **WARNING!** Do not set up the mill on ground with more than a 10 degree incline. Failure to follow this could result in serious injury or death.



If setup on an incline is necessary, put blocks under one side of the mill or dig out areas for the outrigger legs to keep mill level. Setting up the mill on an incline could cause it to tip over.
-  **WARNING!** Chock the trailer wheels to prevent movement before unhitching it from the towing vehicle. Failure to follow this could result in serious injury or death.

-  **WARNING!** Put front outrigger down before moving saw head from the rest position. Failure to follow this could result in serious injury or death.
-  **WARNING!** Always make sure the trailer is supporting the sawmill frame when operating a sawmill with adjustable outriggers. Failure to follow this could result in serious injury or death. The adjustable outriggers are intended to support the saw frame with assistance from the trailer.
-  **WARNING!** The adjustable outriggers supplied with portable sawmills are not intended for setup on concrete or other hard surfaces. Long-term use of the adjustable outriggers on hard surfaces could cause the outriggers to fail. If setting the sawmill up on concrete or other hard surface, replace the adjustable outrigger legs with stationary legs. Failure to follow this could result in serious injury or death.
-  **WARNING!** Securely fasten the feet of a stationary sawmill to the floor before operating the sawmill. Failure to follow this could result in serious injury or death.

CHECK SAWMILL BEFORE OPERATION



-  **DANGER!** Ensure the blade housing and pulley covers are in place and secure. Failure to follow this could result in serious injury or death.
-  **DANGER!** Ensure all guards and covers are in place and secured before operating or towing the sawmill. Failure to follow this could result in serious injury or death.
-  **DANGER!** Do not use blades with stress cracks. Failure to follow this could result in serious injury or death.

KEEP PERSONS AWAY

-  **DANGER!** Stay clear of the area between the trailer axle and saw carriage. Failure to follow this will result in serious injury or death.
-  **DANGER!** Keep all persons out of the path of moving equipment and logs when operating sawmill or loading and turning logs. Failure to follow this will result in serious injury or death.
-  **DANGER!** Always be sure the blade is disengaged and all persons are out of the path of the blade before starting the engine or motor. Failure to follow this will result in serious injury or death.





KEEP HANDS AWAY

-  **DANGER!** Always disengage the blade and shut off the sawmill engine before changing the blade. Failure to follow this will result in serious injury or death.
-  **DANGER!** Engine components can become very hot during operation. Avoid contact with any part of a hot engine. The exhaust components of

your engine are especially hot during and following operation. Contact with hot engine components can cause serious burns. Therefore, never touch or perform service functions on a hot engine. Allow the engine to cool sufficiently before beginning any service function.

 **DANGER!** Always keep hands away from moving bandsaw blade. Failure to follow this will result in serious injury or death.

 **DANGER!** Always be aware of and take proper protective measures against rotating shafts, pulleys, fans, etc. Always stay a safe distance from rotating members and make sure that loose clothing or long hair does not engage rotating members resulting in serious injury or death.

 **WARNING!** Do not spin the blade wheels by hand. Spinning the blade wheels by hand could result in serious injury or death.

 **WARNING!** Always disengage the clutch/brake mechanism whenever the sawmill is not cutting. Failure to follow this could result in serious injury or death.



 **WARNING!** Do not for any reason adjust the engine drive belts or belt support bracket with the engine running. Doing so could result in serious injury or death.

 **WARNING!** Always keep clear of exiting sawdust. Keep hands, feet and any other objects away from the sawdust chute when operating sawmill. Failure to follow this could result in serious injury or death.

KEEP SAFETY LABELS IN GOOD CONDITION

 **IMPORTANT!** Inspect all safety decals to ensure they are clean and readable. Replace all damaged safety decals to prevent personal injury or damage to the equipment. Contact your local distributor, or call your Customer Service Representative to order more decals.

 **IMPORTANT!** If replacing a component which has a safety decal affixed to it, make sure the new component also has the safety decal affixed.

USE CAUTION WHEN WORKING WITH HEAVY LOGS

 **WARNING!** Always make sure log is clamped securely before sawing. Failure to follow this could result in serious injury or death.

 **WARNING!** Always leave optional hydraulic loading arm halfway up while log is on sawmill bed. Failure to follow this could result in serious injury or death.

AUTOMATIC BOARD RETURN SAFETY

 **DANGER!** Keep all persons out of the path of returning boards. Failure to follow this will result in serious injury or death.

 **WARNING!** The automatic board return is intended to assist a second operator in removing boards quickly. Do not use the board return when operating the sawmill alone. Serious injury, death or damage to the equipment could result.

 **WARNING!** Never use the board return table as a platform to stand on. This table is designed and intended to assist in the removal of boards only. Standing on the table could result in serious injury or death.

UP/DOWN SYSTEM SAFETY

 **WARNING!** Always secure the saw head with a 5/16" chain with at least 1900 lbs. working load capacity before adjusting the up/down chain. The saw head could fall, causing severe injury or death.

 **WARNING!** Always secure the saw head with a 5/16" chain with at least 1900 lbs. working load capacity before adjusting the mast pads. The saw head could fall, causing severe injury or death.

 **WARNING!** Always secure the saw head with a 5/16" chain with approximately 1900 lbs. working load capacity before removing the up/down motor belt. The saw head could fall, causing severe injury or death.

POWER FEED SYSTEM SAFETY

 **DANGER!** If leaving the blade engaged for maximum production rates, make sure the off-bearer stays out of the path of the blade. Failure to follow this will result in serious injury or death.

 **WARNING!** Be sure the power feed switch is in the neutral position before turning the key switch to the on (#1) or accessory (#3) position. This prevents accidental carriage movement which may cause serious injury or death.

GENERAL TRAILER SAFETY

 **DANGER!** Make sure your hitch has adequate safety chain hookups. Do not use eyebolts for safety chain hook-up. Safety chains should be hooked to bumper of vehicle so that each chain would pull the trailer equally in the event the hitch became disengaged. Failure to follow this will result in serious personal injury and/or severe machine damage.

 **DANGER!** Be sure that the hitch and safety chains are secure before towing the sawmill. Failure to follow this will result in serious personal injury and/or severe machine damage.

 **DANGER!** Make sure all light connections have been made and are working properly before towing the sawmill. Failure to follow this will result in serious personal injury and/or severe machine damage.

 **WARNING!** The trailer option is designed for the express purpose of towing the sawmill it is supplied with. Do not make modifications or additions that affect the weight and/or stability of the towing unit. Doing so could result in property damage and/or serious injury or death.

 **WARNING!** Always check trailer tires for proper inflation before towing sawmill. Failure to follow this could lead to tire failure resulting in property damage and/or serious injury or death.

 **CAUTION!** Move the optional hydraulic turner to provide maximum ground clearance before towing. Failure to follow this could result in damage to the sawmill.

ADDITIONAL SAFETY FOR ELECTRIC BRAKE TRAILERS

 **DANGER!** Make sure the electric brake wire is secured as close to the trailer axle as possible to prevent wire disconnection during towing. Failure to follow this will result in serious personal injury or death.

 **DANGER!** Be sure electric brake battery is charged and is working properly before towing the sawmill. Failure to follow this will result in serious personal injury or death.

 **DANGER!** Do not use the electric brake system as an “emergency brake” while the sawmill is not being towed. Extended use of the electric brakes while the sawmill is stationary will drain the brake battery.

USE PROPER PROCEDURE WHEN CONDUCTING ELECTRICAL SAFETY CHECKS AND MAINTENANCE

 **DANGER!** Make sure all electrical installation, service and/or maintenance work is performed by a qualified electrician and is in accordance with applicable electrical codes.

 **DANGER! ARC FLASH AND SHOCK HAZARD!** Hazardous voltage inside the electric sawmill disconnect box, starter box, and at the motor can cause shock, burns, or death. Disconnect and lock out power supply before servicing! Keep all electrical component covers closed and securely fastened during mill operation. Wear appropriate Personal Protection Equipment.



 **WARNING!** Consider all electrical circuits energized and dangerous. Failure to follow this could result in shock, burns, or death.

 **WARNING!** Disconnect the negative battery terminal cable before performing any service to the 12-Volt electrical system. Failure to follow this could result in injury and/or electrical system damage.

 **WARNING!** Never assume or take the word of another person that the power is off; check it out and lock it out. Failure to follow this could result in shock, burns, or death.

 **WARNING!** Do not wear rings, watches, or other jewelry while working around an open electrical circuit. Failure to follow this could result in shock, burns, or death.



WARNING! Before performing service near moving parts such as blades, pulleys, motors, belts and chains, first turn the key switch to the OFF (#0) position and remove the key. If the key is turned on and moving parts activated, serious injury or death could result.

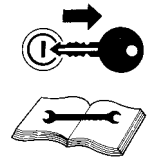

WARNING! Remove the blade before performing any service to the engine or sawmill. Failure to follow this could result in serious injury or death.

2.2 Electrical Lockout Procedures

RULES FOR USING LOCKOUT PROCEDURE

The sawmill shall be locked out to protect against accidental or inadvertent operation when such operation could cause injury to personnel. Do not attempt to operate any switch or valve bearing a lock.

LOCKOUT PROCEDURES MUST BE USED DURING:

Cleaning	Electrical maintenance
Mechanical repair	Retrieval of tools/parts from work area
Unjamming operations	Activities where guards or electrical panel guard is open or removed
Changing or adjusting blades	

MAINTENANCE HAZARDS INCLUDE:

Kickbacks	Electrical
Pinch points	Missiles (thrown blades/wood chips)
Blade contact	

FAILURE TO LOCKOUT MAY RESULT IN:

Cut	Burn
Crush	Shock
Puncture	Amputation
Blindness	Serious injury and death
Electrocution	

TO CONTROL MAINTENANCE DANGERS:

- Lockout procedures must be followed (see OSHA regulation 1910.147).
- Never rely on machine stop control for maintenance safety (emergency stops, on/off buttons, interlocks).
- Do not reach into moving blades or feed systems. Allow all coasting parts to come to a complete stop.
- Electrical power supply and air supply must both be locked out.
- Where established lockout procedures cannot be used (electrical troubleshooting or mechanical dynamic troubleshooting), alternative effective protective techniques shall be employed which may require special skills and planning.
- Always follow safe operations practices in the workplace.

SAWMILL LOCKOUT PROCEDURE

Lockout procedures per OSHA regulation 1910.147, appendix A:

GENERAL

The following simple lockout procedure is provided to assist owner/operators in developing their procedures so they meet the requirements of OSHA regulation 1910.147. When the energy isolating devices are not lockable, tagout may be used, provided the owner/operator complies with the provisions of the standard which require additional training and more rigorous periodic inspections. When tagout is used and the energy isolating devices are lockable, the owner/operator must provide full operator protection (see OSHA regulation 1910.147, paragraph (c)(3)) and additional training and more rigorous periodic inspections are required. For more complex systems, more comprehensive procedures may need to be developed, documented, and utilized.

PURPOSE

This procedure establishes the minimum requirements for the lockout of energy isolating devices whenever maintenance or servicing is done on machines or equipment. It shall be used to ensure that the machine or equipment is stopped, isolated from all potentially hazardous energy sources and locked out before personnel perform any servicing or maintenance where the unexpected energization or start-up of the machine or equipment or release of stored energy could cause injury.

COMPLIANCE WITH THIS PROGRAM

All personnel are required to comply with the restrictions and limitations imposed upon them during the use of lockout. The authorized personnel are required to perform the lockout in accordance with this procedure. All operators, upon observing a machine or piece of equipment which is locked out to perform servicing or maintenance shall not attempt to start, energize, or use that machine or equipment.

SEQUENCE OF LOCKOUT

1. Notify all affected personnel that servicing or maintenance is required on a machine or equipment and that the machine or equipment must be shut down and locked out to perform the servicing or maintenance.
2. The authorized employee shall refer to the company procedure to identify the type and magnitude of the energy that the machine or equipment utilizes, shall understand the hazards of the energy, and shall know the methods to control the energy.
3. If the machine or equipment is operating, shut it down by the normal stopping procedure (depress the stop button, open switch, close valve, etc.).
4. De-activate the energy isolating device(s) so that the machine or equipment is isolated from the energy source(s).
5. Lock out the energy isolating device(s) with assigned individual lock(s).
6. Stored or residual energy (such as that in capacitors, springs, elevated machine members, rotating flywheels, hydraulic systems, and air, gas, steam, or water pressure, etc.) must be dissipated or restrained by methods such as grounding, repositioning, blocking, bleeding down, etc.
7. Ensure that the equipment is disconnected from the energy source(s) by first checking that no personnel are exposed, then verify the isolation of the equipment by operating the push button or other normal operating control(s) or by testing to make certain the equipment will not operate.



CAUTION! Return operating control(s) to neutral or "off" position after verifying the isolation of the equipment.

8. The machine or equipment is now locked out.

RESTORING EQUIPMENT TO SERVICE

When the servicing or maintenance is completed and the machine or equipment is ready to return to normal operating condition, the following steps shall be taken.

1. Check the machine or equipment and the immediate area around the machine to ensure that nonessential items have been removed and that the machine or equipment components are operationally intact.
2. Check the work area to ensure that all personnel have been safely positioned or removed from the area.
3. Verify that the controls are in neutral.
4. Remove the lockout devices and re-energize the machine or equipment.

NOTE: The removal of some forms of blocking may require re-energization of the machine before safe removal.

5. Notify affected personnel that the servicing or maintenance is completed and the machine or equipment is ready for use.



IMPORTANT! In the preceding steps, if more than one individual is required to lock out the sawmill, **each shall place his own personal lock on the energy isolating devices.**

SECTION 3 SAWMILL SETUP

3.1 Stationary Sawmill Setup

Prepare the site:

- Area must be firm and level.
- The cement pad should be rated to support 6350 lbs./sq.ft.
- Use 5/8" diameter anchor bolts to secure feet.
- Allow maneuvering room for operators, sawdust removal, log loading, and board removal.

- [See Section 3.2](#) for installation instruction for adjustable outriggers.
- [See Form #847](#) for sawmill foot anchor locations.
- [See Form #359](#) for sawmill with bed extension foot anchor locations.
- [See Form #542](#) for complete electric sawmill installation instructions.

NOTE: Make sure the unit is level before securing. It **IS POSSIBLE** to twist the mill frame by jacking one foot higher than the others.



WARNING! Securely fasten the feet to the floor before operating the sawmill. Failure to do so may result in serious injury or death.

1. Unhook the carriage safety chain, located at the bottom of the vertical mast, near the battery box.

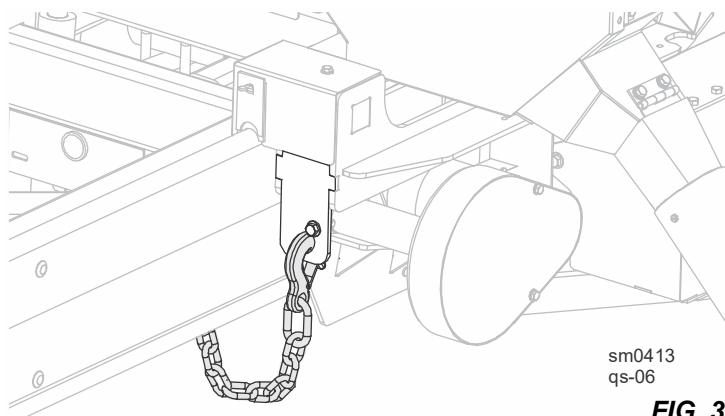

FIG. 3-1

2. Release the fender straps and lift up to remove the fenders.
3. Stow until needed for transport.

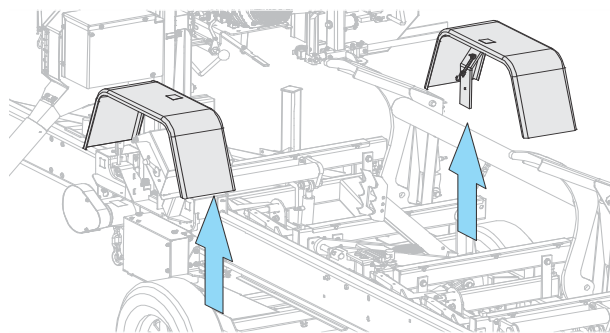
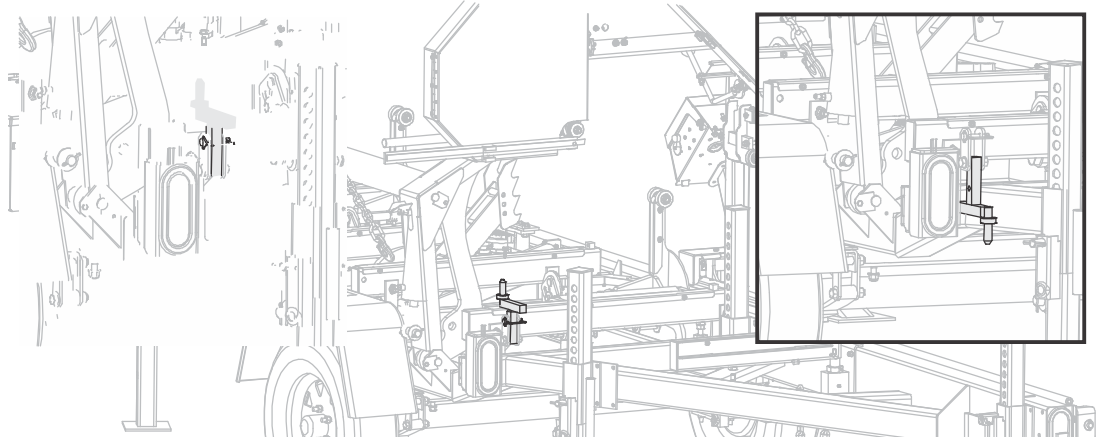

FIG. 3-2

1. Start the engine to enable the battery-operated accessories ([See Section 3.6](#)).

Use the up/down switch on the control panel to raise the cutting head from the carriage rest pin. wing the rest pin down below bed level. **NOTE: Gas/diesel Models Only:** Operating the controls without the engine running will drain the battery.



2. Move the cutting head toward the front (hitch end) of the mill.

3. Raise the side supports to prevent a log from falling off the side of the mill when loaded.

- 1.
- 1.
- 2.
- 3.

3.2 Portable Sawmill Setup



WARNING! Do not set up the mill on ground with more than a 10 degree incline. If setup on an incline is necessary, put blocks under one side of the mill or dig out areas for outrigger legs to keep mill level. Setting up the mill on an incline could cause it to tip over.

Chock the trailer wheels to prevent movement before unhitching it from the towing vehicle. Failure to do so may result in serious injury or death.

Always make sure the trailer is supporting the sawmill frame when operating a sawmill with adjustable outriggers. The adjustable outriggers are intended to support the saw frame with assistance from the trailer.

The fine adjustable outriggers supplied with portable sawmills are not intended for setup on concrete or other hard surfaces. Long-term use of the fine adjustable outriggers on hard surfaces may cause the outriggers to fail, causing the sawmill to drop.

NOTICE If setting the sawmill up on concrete or other hard surface, replace the fine adjustable outrigger legs with stationary legs.

To set outriggers for towing:

1. Hitch the mill to the vehicle.
2. Move the saw head at the front of the sawmill.
3. Use the crank handle to turn the rear outrigger adjustment nut clockwise until the outrigger does not bear weight.
4. Disengage the locking pin retainer and remove the locking pin.
5. Raise the leg all the way up so the bottom-most hole is aligned with the locking pin hole.
6. Replace the locking pin and secure with the retainer.
7. Repeat for the other rear outriggers.
8. Move the saw head to the travel position and raise the front outriggers as described below.
9. Connect the hitch to the towing vehicle and raise the front-most outrigger.

To set outriggers for sawing:

1. Unhitch the mill from the vehicle.
2. With the saw head in the travel position, set the three front outrigger as described below. The front outrigger should always be set before moving the saw head from the travel position.
3. Disengage the locking pin retainer on the front adjustable outrigger.
4. Hold the adjustable leg with one hand and pull out the locking pin. Lower the adjustable leg to align the locking pin holes so the foot pad is as close to the ground as possible.
5. Reinstall the locking pin and secure with the retainer. Use the provided crank handle to turn the outrigger adjustment nut counterclockwise to push the foot pad down to support the weight of the sawmill frame.

See Figure 4.

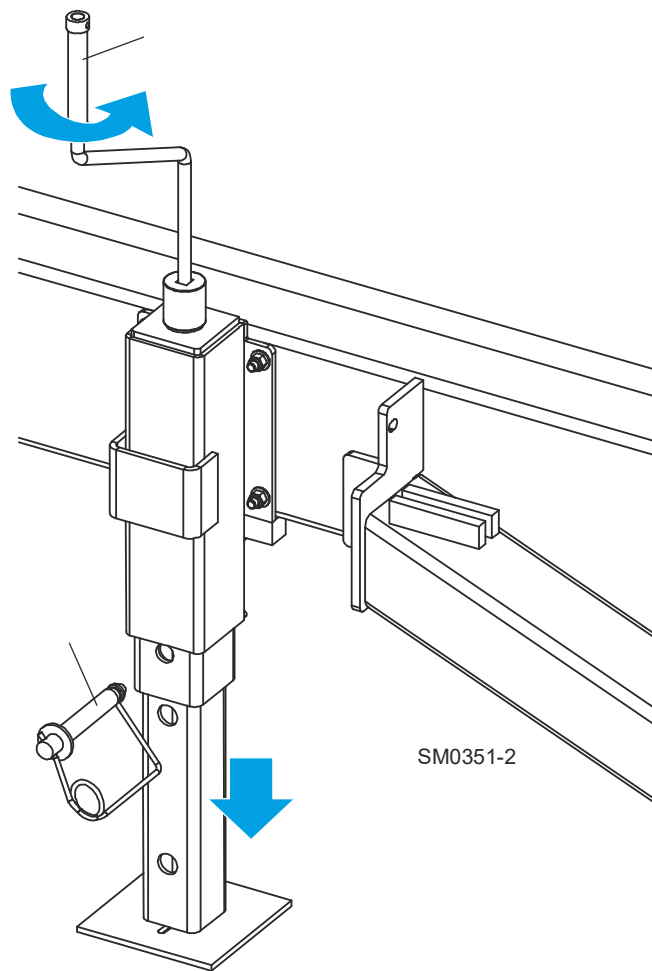

FIGURE 4

WARNING! Put front outrigger down before moving cutting head from the rest position. Failure to do so may result in serious injury.

6. Fine tune the outrigger base height as necessary. Move the cutting head to the opposite end of the mill from the outrigger. Raise the entire outrigger (to remove the sawmill weight from it) and adjust the outrigger base as necessary. Lower the entire outrigger and use the locking pin to secure in position.



CAUTION! Do not adjust the FAO outrigger base height while there is weight on the FAO. Damage to the FAO may result.

7. Move the saw head to the front of the sawmill and adjust the rear outriggers. Rear outrigger adjustment is similar to the front outrigger. Remove the locking pin and adjust the leg down. Replace the locking pin and use the crank to adjust the outrigger as desired.
8. Unhook the carriage safety chain, located at the bottom of the vertical mast, near the battery box.
9. Start the engine to enable the battery-operated accessories ([See Section 3.6](#)). Use the up/down switch on the control box to raise the cutting head from the carriage rest pin. Swing the rest pin down below bed level.



CAUTION! Always make sure the engine is running before operating the sawmill controls. Operating the controls without the engine running will result in power drainage from the battery.

10. Remove the fenders by lifting them out of the slots.



CAUTION! To prevent fender damage, remove fenders before operating sawmill or loading logs.

11. Use the handlefeed control switch (left side of control box) to move the cutting head toward the front end of the mill.
12. Lower and set the remaining rear outriggers. Level the sawmill by adjusting the outriggers to raise or lower each end of the sawmill. Adjust all outriggers evenly to avoid twisting the mill frame by jacking one outrigger higher than the others.
13. Raise the two side supports to prevent the log from falling off the side of the mill when loaded.

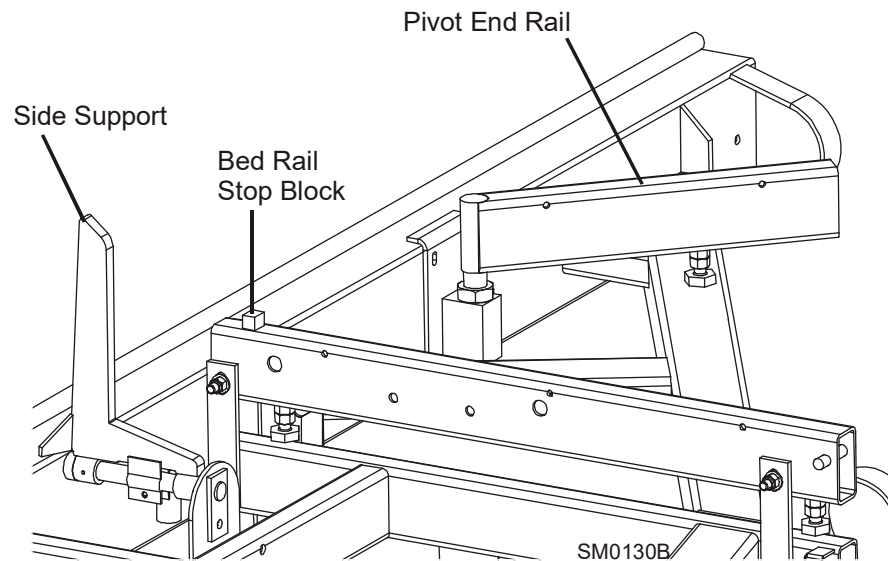

FIG. 3-1

3.3 Replacing The Blade



DANGER! Always disengage the blade and shut off the sawmill engine before changing the blade. Failure to do so will result in serious injury.



WARNING! Always wear gloves and eye protection when handling bandsaw blades. Changing blades is safest when done by one person! Keep all other persons away from area when coiling, carrying or changing a blade. Failure to do so may result in serious injury.

1. the blade housing covers that cover the blade wheels. Lower the hinged middle blade housing cover.
2. Turn the blade tension handle to release the blade tension until the wheel is pulled in and the blade is lying loose in the blade housing.
3. Lift the blade out of the blade housing.
4. Make sure the teeth are pointing the correct direction. See FIG. 3-2.

The cutting teeth should be pointing toward sawdust chute.

5. Install the blade so it is lying around the wheels.

CAUTION! Be careful when placing the blade between the guide rollers and inserts. If the blade hits one of the inserts hard enough, it could damage the insert.

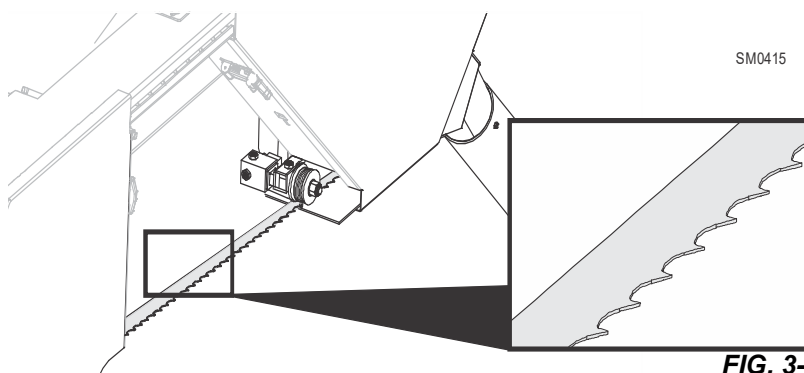

FIG. 3-2

6. Position 1 1/4" wide blades on the wheels so the gullet is 1/8" (3.0 mm) out from the edge of the wheel; position 1 1/2" wide blades on the wheels so the gullet is 3/16" (4.5 mm) out from the edge of the wheel.
7. Close the middle blade housing cover.
8. Use the tension handle to tension the blade correctly.

3.4 Tensioning The Blade

Tension the blade by turning the hydraulic tensioning handle clockwise until the tension gauge indicates the recommended tension.

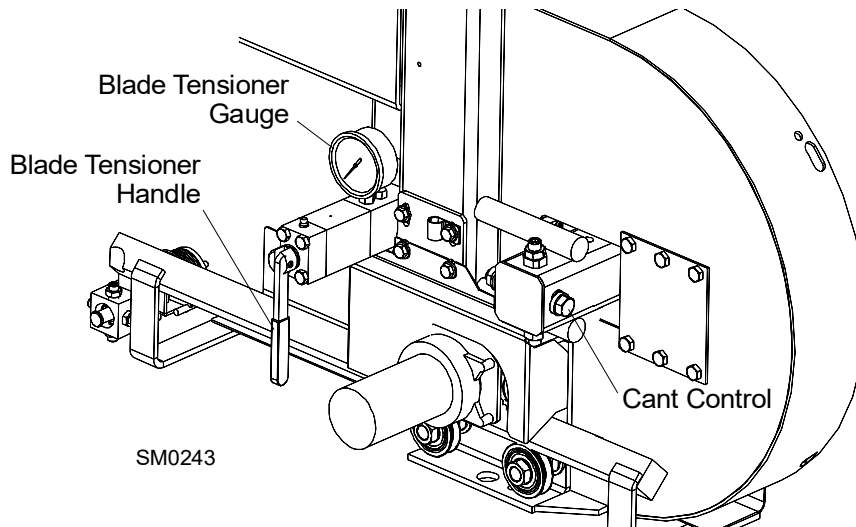

FIG. 3-3

The recommended tension for different blades is shown below.

Blade Type	Acceptable Range
All Blades	2800 - 3000 psi

TABLE 3-1

The tension gauge should be checked occasionally when adjusting the cant control or while cutting. Ambient temperature changes will cause tension to change. Adjust the tension handle as necessary to maintain the recommended tension level.

CAUTION! Changes in temperature could cause increased pressure in the blade tensioner and loss of fluid from the gauge. Release the blade tension when the mill is not in use to avoid damage to the tensioner.

3.5 Tracking The Blade

1. Make sure the blade housing covers are secured and all persons are clear of the saw head.
2. Start the engine (or motor).
3. Engage the blade, rotating the blade until the blade positions itself on the wheels.



WARNING! Do not spin the blade wheels by hand. Spinning the blade wheels by hand may result in serious injury.

4. Disengage the blade. Turn off the engine, remove the key and check the position of the blade on the blade wheels.

Position 1 1/4" blades so that the gullet is 1/8" (3.0 mm) out from the edge of the blade wheel ($\pm 1/16$ [1.5 mm]).
Position 1 1/2" blades so that the gullet is 3/16" (4.5 mm) out from the edge of the blade wheel ($\pm 1/16$ [1.5 mm]).

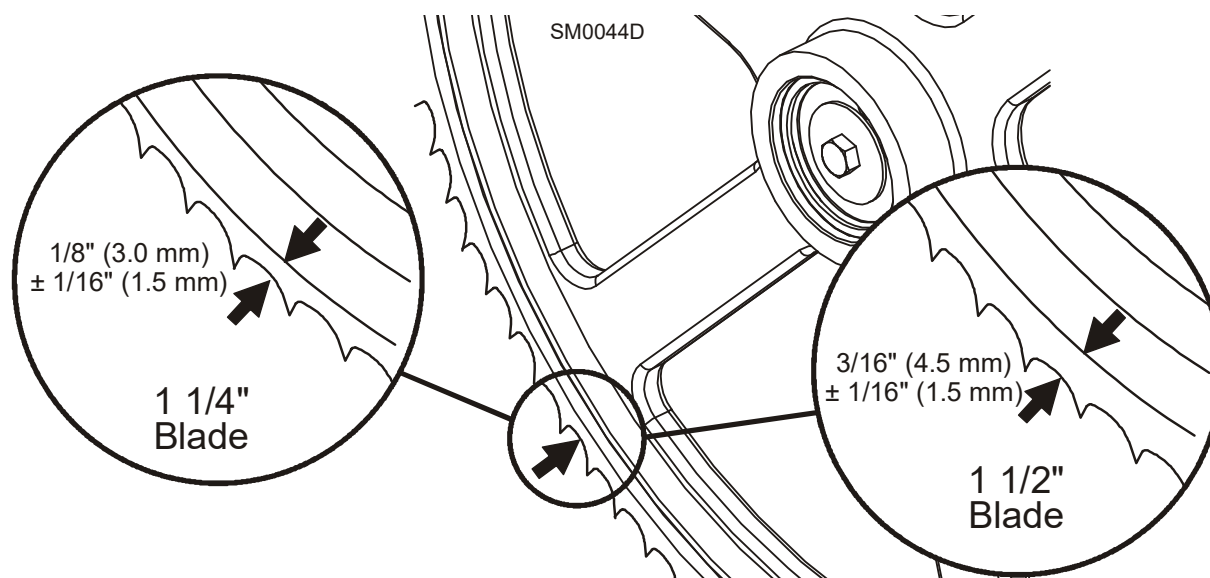

FIG. 3-4

5. To adjust where the blade travels on the blade wheels, use the cant control shown in Figure .

If the blade is too far out, back the blade onto the wheel by turning the cant control counterclockwise. If the blade is too far in, turn the cant control clockwise until the gullet of the blade is the correct distance from the front edge of the wheel.

6. Adjust the blade tension if necessary to compensate for any changes that may have occurred while adjusting the cant control.



DANGER! Ensure all guards, covers, blade housings, and pulley covers are in place and secured before operating or towing the sawmill.

NOTICE After aligning the blade on the wheels, always double-check the blade guide spacing and location. ([See Section SECTION 7](#) for more information.)

3.6 Starting The Engine or Motor

See the appropriate manual supplied with your specific engine/motor configuration for starting and operating instructions.



DANGER! Make sure all guards and covers (including the blade housing and pulley covers) are in place and secured before operating or towing the sawmill.

Always be sure the blade is disengaged and all persons are out of the path of the blade before starting the engine or motor.



WARNING! Always wear eye, ear, respiration, and foot protection when operating the sawmill.

Be sure the power feed switch (if equipped) is in the neutral position before turning the key switch to the on (#1) or accessory(#3) position to prevent accidental carriage movement .

3.7 Board Return



WARNING! The automatic board return is intended to assist a second operator in removing boards quickly. Do not use the board return when operating the sawmill alone.

WARNING! Do not stand on the board return table.

The sawmill is equipped with a board return system. This system consists of an arm on the saw head controlled by a toggle switch on the control panel. A board return table is also provided to catch the board as it is removed from the log. Use of the board return not recommended with material shorter than 8 foot.

To activate the board return, turn the key switch to the accessory (#3) or start (#1) position. Push the toggle switch on the control panel down. The board return arm located in the middle of the saw head will drop into position.

When the blade reaches the end of the log, the arm will drop down to catch the board and drag it back toward the operator as the saw head is returned.



WARNING! Keep all persons out of the path of returning boards.

Boards may not always return in the same path or location. If a board returns in a manner that does not allow the sawyer or off-bearer to maintain control, it may be necessary to stop the reverse motion of the saw head.

When the board return is to be used, a second person is required to remove the board as it is returned. DO NOT attempt to use the board return feature when sawing alone.

To bypass the board return feature, push the toggle switch on the control panel up.

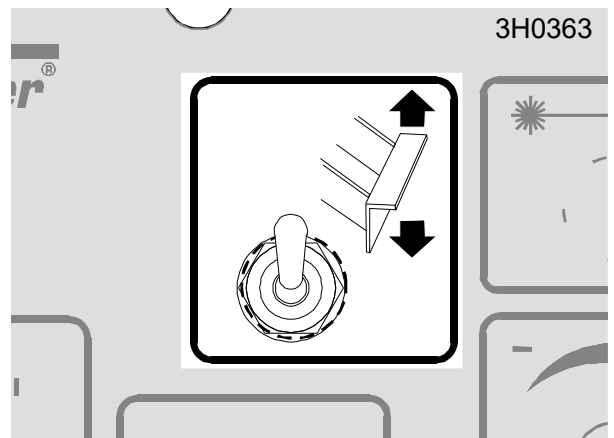

FIG. 3-5

SECTION 4 SAWMILL OPERATION

4.1 Optional Hydraulic Log Loader/Turner Control Operation

The hydraulic control levers become operational when the contacts at the bottom of the carriage touch the power strip on the frame tube. The hydraulic control levers will only work when the cutting head is close enough to the front end of the mill to touch the power strip.

The optional dual-function hydraulic control allows the operator to load and turn logs on the sawmill by operating the control levers.

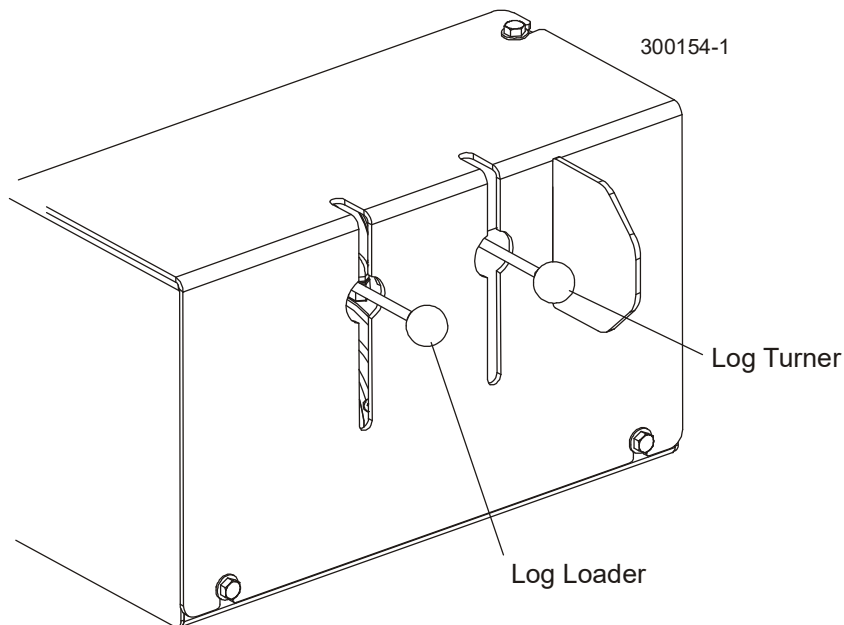

FIG. 4-1

Use the hydraulic control lever(s) to get the mill ready to load a log.



DANGER! Keep all persons out of the path of moving equipment and logs when operating sawmill or loading and turning logs. Failure to do so will result in serious injury.



CAUTION! Always make sure the engine is running before operating the hydraulic controls. Operating the controls without the engine running will result in power drainage from the battery. Holding the hydraulic switches halfway up or down also will cause excessive drainage from the battery.

1. Remove the clamp from the sawmill bed so it will not get in the way of logs being loaded onto the bed.
2. Remove the two retaining pins holding the log loader in the towing position.

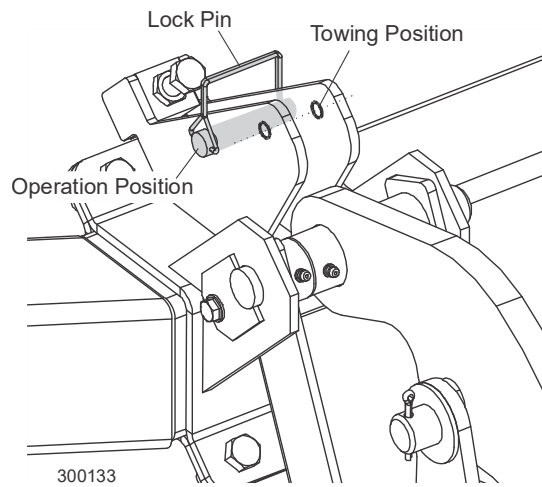
**FIG. 4-2**

3. If the sawmill is equipped with the optional hydraulic log turner, remove the travel plate. Lift the turner arm and pull the plate from underneath the turner arm elbow.

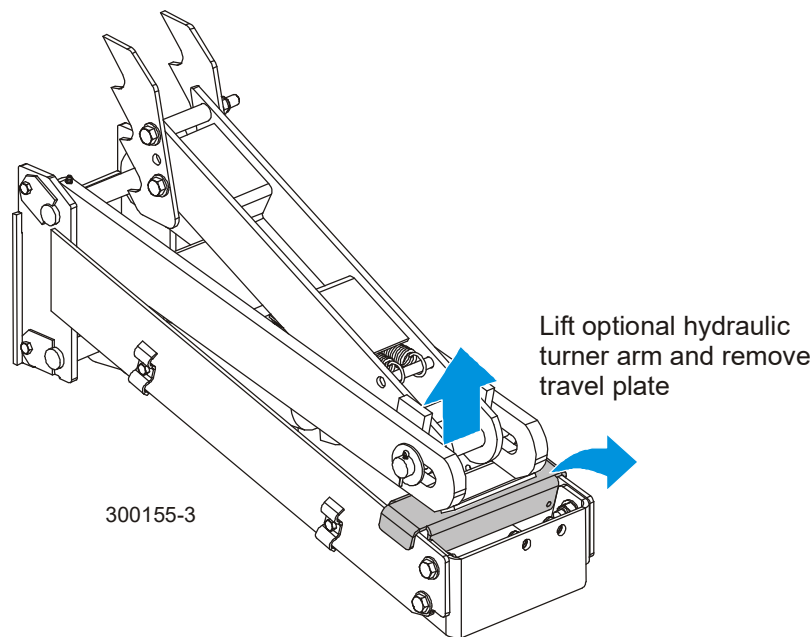
**FIG. 4-3**

4. Lower the turner lever to completely lower the turner arm. Notice that after the turner arm is all the way down, the side support braces will begin to lower. Release the turner lever after the turner arm is lowered, but before the side supports begin to lower. This stops the log being loaded from damaging the turner and/or falling off the side of the sawmill.
5. When raising the turner lever, the side supports rise first. After reaching a fully vertical position, the turner arm will engage and start to rise.
6. Manually lower the log loader so it rests on the ground.



CAUTION! Be careful when manually lowering the log loader. Do not drop the loader onto the ground or perform any action which might break the velocity fuse valves on the loader cylinders. These valves control hydraulic flow and are necessary to prevent the loading arm from collapsing during use.

7. Place the retaining pins in the operation position holes.
8. The front and rear toe boards should be below bed level. Once a tapered log has been loaded, the front or rear end of the log may be lifted to parallel the heart of the log to the path of the blade.

4.2 Loading, Turning And Clamping Logs

TO LOAD LOGS

1. Start the engine and move the saw carriage to the front end of the frame.



CAUTION! Before loading a log, be sure the saw head is moved far enough forward so the log does not hit it. Failure to do so may result in machine damage.



CAUTION! Be sure the log clamp, pivot rails, turning arm and toe boards are adjusted out of the path of the log before loading a log onto the bed. Failure to do so may result in machine damage or cause misalignment.

2. Raise the side supports to prevent the log from falling off the side of the bed.

Standard Log Ramps (See next page for optional Hydraulic Loader operation):

3. Place the loading ramps on the two bed rails that will support the length of the log. **NOTE:** The loading ramps cannot be fastened securely to the bed rail located directly above the tire. Do not use this rail.
4. Position the log at the foot of the ramps.
5. Remove the winch cable from the log turner (if applicable) and route the cable over the top of the log. Wrap the cable around and underneath the log. Hook the cable to the third hole in the log clamp bracket. See *Winch Operation Manual*.

DANGER! Keep all persons out of the path of moving equipment and logs when operating sawmill or loading and turning logs. Failure to do so will result in serious injury.



6. Crank the winch to begin rolling the log up the ramps and onto the sawmill bed. Keep the log centered on the ramps as it rolls up.
7. Once the log is on the sawmill bed, place the log clamp in the clamp bracket. This will stop the log from rolling back off the side of the mill when you remove the winch cable.

Use cant hooks or loading equipment to move the log to the foot of the loading arms. **Optional Hydraulic Log Loader:**

4. Roll the log onto the loader so that it is approximately centered with the sawmill bed.

The log turner will operate much easier if the log is centered on the sawmill bed.



DANGER! Keep all persons out of the path of moving equipment and logs when operating sawmill or loading and turning logs.

5. Hold the **LOG LOADER** lever up until the log rolls onto the mill bed.
6. Clamp the log and lower the loading arm.
7. Leave the loading arm about halfway up while squaring the log. This will stop the log from rolling off the side of the mill.



WARNING! Always leave loading arm halfway up while log is on sawmill bed.

NOTE: Logs also may be loaded onto the mill with a tractor or other equipment specifically designed for that purpose.



CAUTION! Do not drop the log on the bed. Damage to the frame may occur.

TO TURN LOGS

Standard Log Turner (See below for optional Hydraulic Turner operation):

1. Use cant hooks or the optional manual log turner to rotate the log on the sawmill bed. See *Log Turner Manual*.
2. Spin the log against the side supports until it is turned the way you want it for the first cut.

Optional Hydraulic Log Turner:

1. Raise the log turner until the arm touches the log and starts to turn it.
2. Spin the log against the side supports until it is turned the way you want it for the first cut.
3. To turn the log more, clamp the log against the side supports and lower the turner arm below the log.
4. Raise the turner arm to get a new bite on the log.
5. Disengage the clamp and continue turning the log.
6. Repeat steps 3 through 5 until the log is turned as desired.

TO CLAMP LOGS

1. Position the log clamp in the bracket in the hole closest to the log.
2. Move the clamp down far enough so that it is below your first few cuts. Pivot the clamp so that it moves the log firmly against the side supports. Lock the clamp in position with the locking chain.

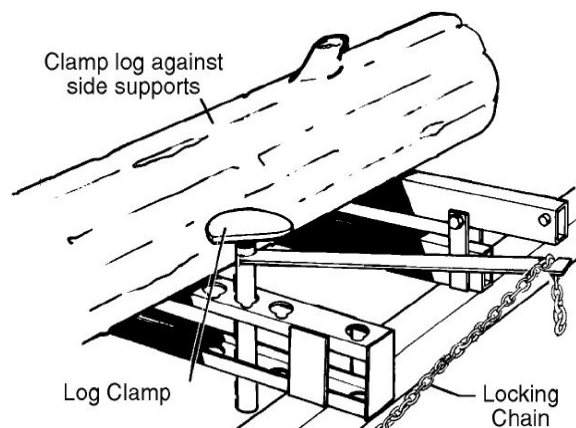

FIG. 4-4

3. Make sure the side supports are positioned low enough for the blade to pass over them. If they are not, back the clamp off slightly and push the side supports down until they are positioned below the level of your first few cuts.
4. Use the optional toe boards to level the log if desired. See the manual supplied with the manual toe boards for details concerning toe board operation.

TO LEVEL A TAPERED LOG

Use the optional toe boards to raise either end of a tapered log, if desired. See the Toe Board Option Manual for operating instructions.

4.3 Manual Up/Down Operation

This section describes operation of the up/down system with the standard controls. See the operation section of the Accuset 2 manual for alternate instructions for operating the up/down system.

1. Install a blade, if needed, and check for correct blade tension. ([See Section 3.3](#)).
2. Set the saw head to the desired height. (The blade height scale shows the height of the blade above the bed rails.)

The up/down switch is located on the right side of the control panel. Use the switch to raise or lower the saw head. Hold the switch in position until the saw head reaches the desired height, then release.

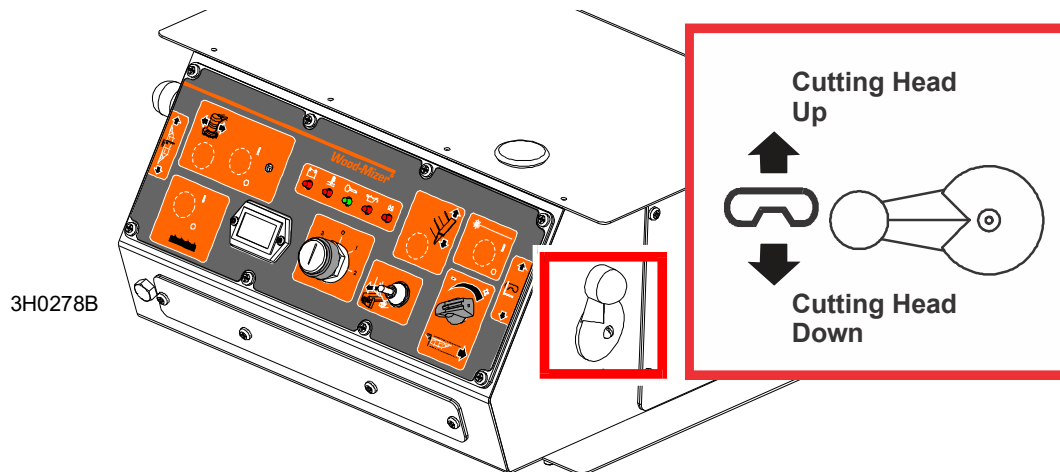

FIG. 4-5 ALL EXCEPT TIER 4 ENGINE

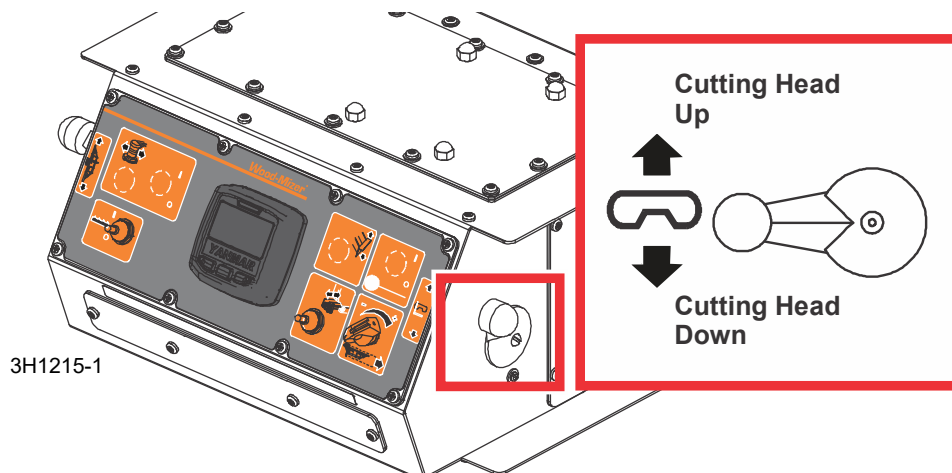

FIG. 4-6 TIER 4 ENGINE ONLY

The up/down switch is designed to return to the neutral or "off" position when released. If the switch remains engaged, manually move the switch to the neutral or "off" position. Repair the up/down switch ([See Section 6.2](#)).



CAUTION! Always make sure the up/down switch moves to the neutral or "off" position when released to ensure that the saw head stops moving. Failure to do so may result in machine damage.

DO NOT force the carriage above the 35" (88 cm) mark or below the 1" (2.54 cm) mark. Damage to the up/down system may result.

4.4 Blade Guide Arm Operation

1. Look down the length of the log to see its maximum width. The outer blade guide should be adjusted to clear the widest section of the log by less than 1" (25.4 mm).

2. Use the blade guide toggle switch on the control panel to adjust the outer blade guide as necessary. Push the switch to the left to move the arm in. Push the switch to the right to move the arm out.

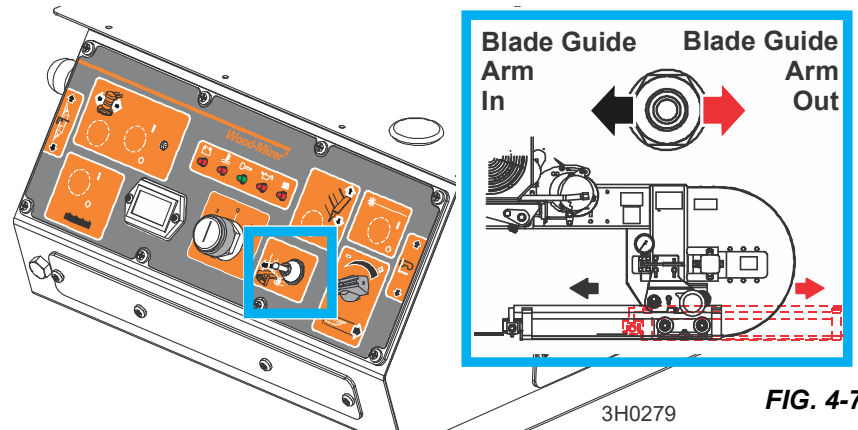

3. Use the blade guide toggle switch to readjust the outer blade guide as you are cutting in order to keep the guide within 1" (2.5 cm) of the log. Be sure to adjust the arm back out before returning the carriage.

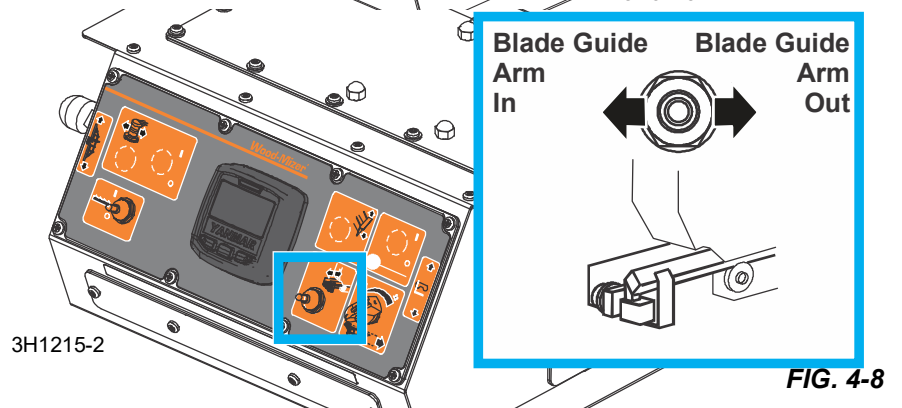

4.5 Clutch/Brake Operation

NOTE: If your sawmill is equipped with the Autoclutch Option, see the [Autoclutch Option manual](#) for clutch operating instructions.

1. Clear any loose objects from the area of the blade, motor, and drive belt.
2. Make sure the clamp and side supports are adjusted below the level of the first few cuts.
3. Start the engine or motor as instructed in the option manual.

 **DANGER!** Keep all persons out of the path of moving equipment and logs when operating sawmill or loading and turning logs. Failure to do so will result in serious injury.

Be sure the blade housing and pulley covers are in place and secure before starting the engine or motor. Use the safety retainer pin and cable to fasten the blade housing covers shut.

The clutch/brake lever is located next to the engine.

See Figure 4-9.

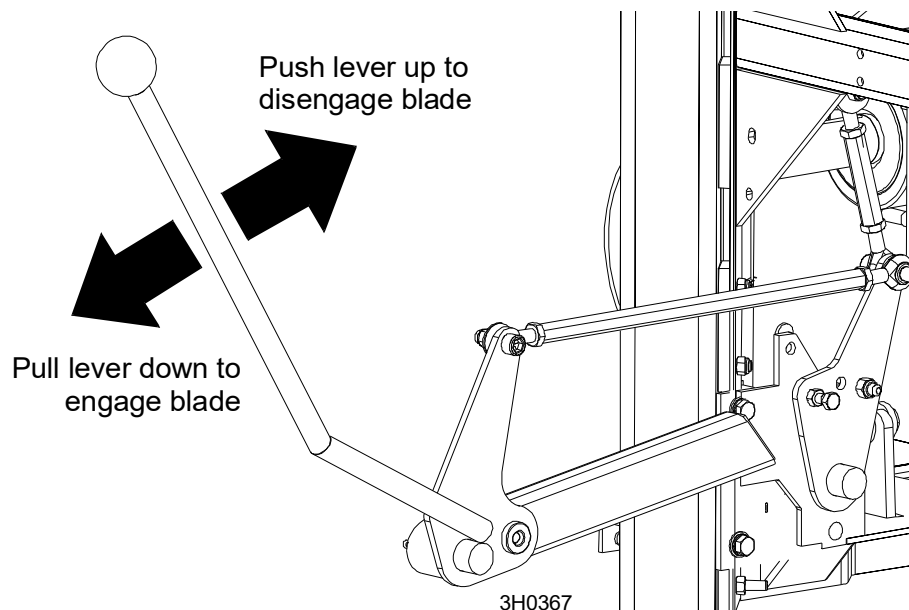

FIG. 4-9

4**Sawmill Operation***Clutch/Brake Operation*

4. To engage the blade, pull the clutch/brake lever down until it locks in the down position. This engages the drive mechanism, releases the blade brake, and increases the engine speed to full throttle.

5. To disengage the blade, raise the clutch/brake lever to the up position. This disengages the drive belt, engages the blade brake, and returns the engine to idle.

4.6 Power Feed Operation

The power feed system moves the carriage forward and backward by using two switches on the control panel.

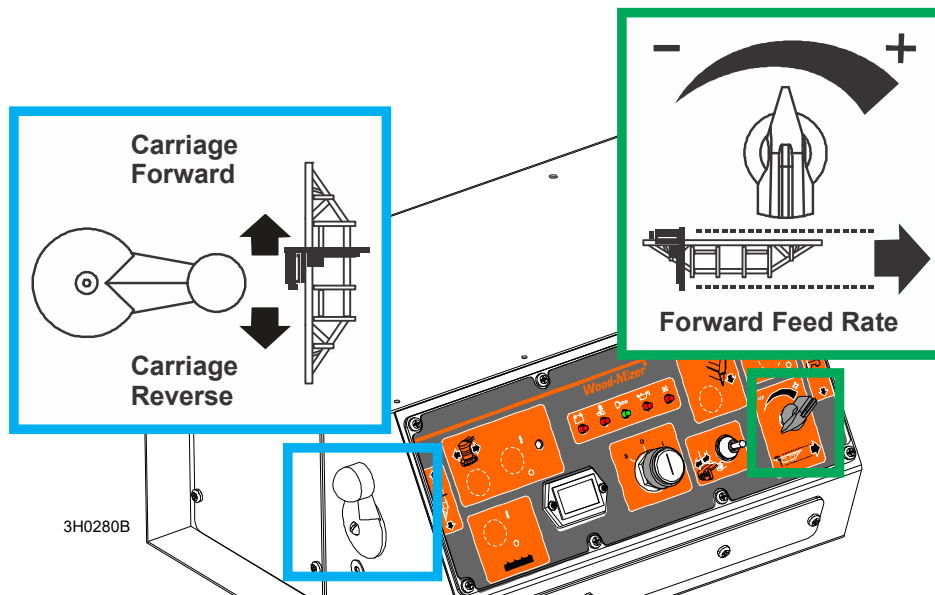

FIG. 4-10 ALL EXCEPT TIER 4 ENGINE

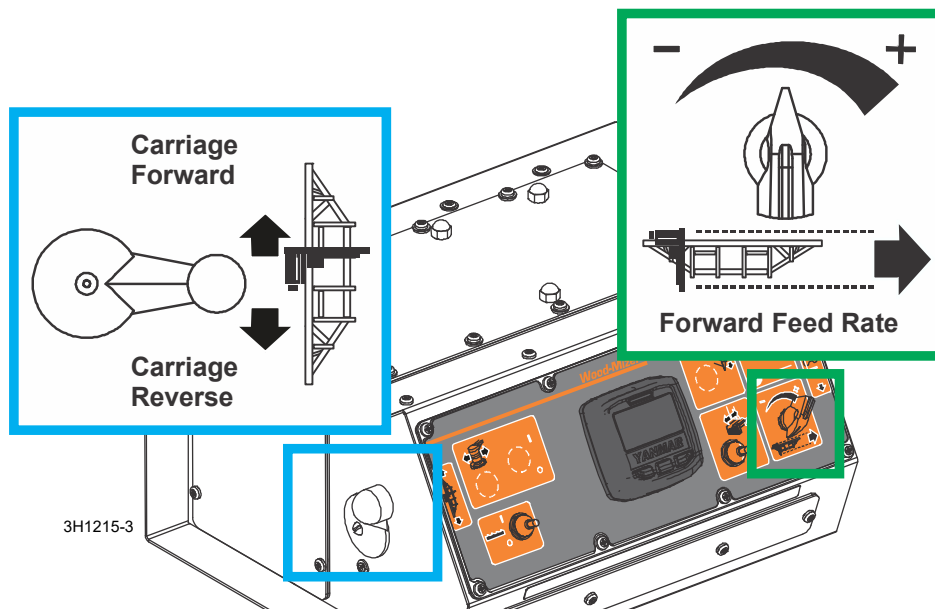

FIG. 4-11 TIER 4 ENGINE ONLY

CARRIAGE FEED RATE

The carriage feed rate switch controls the speed at which the carriage travels forward. Turn the switch clockwise to increase speed. Turn it counterclockwise to reduce speed.

CARRIAGE FORWARD AND REVERSE

The carriage forward/reverse switch controls the direction in which the carriage travels. Use the forward/reverse switch to move the carriage forward or backward.

The middle position (as shown) is the neutral position. The power feed switch is designed to return to the neutral or "off" position when released from operating in the reverse position. If the switch remains engaged, manually move the switch to the neutral or "off" position. Repair the switch ([See Section 5.6](#)).



WARNING! Be sure the power feed switch is in the neutral position before turning the key switch to the on (#1) or accessory (#3) position.

USING THE POWER FEED

1. To move the carriage forward, push the forward/reverse switch forward and turn the feed rate switch clockwise.

NOTE: To get a straight cut in the first part of the board, feed the blade into the log at a slow speed. This stops the blade from flexing and dipping up or down. Turn the carriage feed rate switch to a slow speed until the whole width of the blade has entered the cut. Then use the carriage feed rate switch to increase the feed rate as desired. Maximum feed rate varies with width and hardness of the wood. Over-feeding results in engine and blade wear, and also produces a wavy cut.

2. Stop the carriage at the end of the cut by turning the carriage feed rate switch counterclockwise until the carriage stops moving. Throw the clutch/brake lever up or the optional autoclutch toggle switch down to stop the blade and drop the engine to idle.
3. Remove the board from the top of the log. **Always disengage the blade before returning the carriage for the next cut.**



CAUTION! Be sure to stop the blade when returning the carriage. This will not only prevent the blade from being pulled off and ruined by a wood sliver, but also will increase the life of the blade. [See Section 4.9](#) for optional sawing procedure for Super series mills.

4. Raise the carriage slightly to ensure the blade clears the log when returned.
5. Return the carriage to the front of the mill by pushing the forward/reverse switch down. The power feed motor will bypass the carriage feed rate switch and the carriage will automatically return at the fastest speed available. [See Section 4.9](#) for optional sawing procedure for Super series mills.

NOTE: Try to stop the blade while the heel of the blade is still on the log. Then bring the carriage back without adjusting the blade up. This lets you keep the blade at the current height setting so you can make the next blade height adjustment more quickly.



DANGER! Stay clear of the area between the trailer axle and saw carriage. Failure to do so will result in serious injury.

4.7 Cutting The Log

1. Once the log is placed where you want it and clamped firmly, move the saw head to position the blade close to the end of the log.
2. Use the blade height scale to determine where to make your first cut ([See Section 4.10](#)). The blade height scale will help you to do this. Set the blade to the desired height with the up/down switch. Make sure that the blade will clear all side supports and the clamp. Adjust the outer blade guide to clear the widest section of the log by moving the blade guide toggle switch.

NOTE: An optional laser sight is available to help determine where the blade will travel through the log. See the laser sight manual for detailed operating instructions.

3. Engage the clutch/brake lever (or autoclutch blade switch) to start the blade spinning.
4. Start the water lube if necessary to prevent sap buildup on the blade. [See Section 4.11](#).
5. If you want to use the board return function, push the toggle switch on the control panel down. [See Section 3.7](#).
6.  Feed the blade into the log slowly ([See Section 4.6](#)). Once the blade completely enters the log, increase the feed rate as desired. Always try to cut at the fastest speed you can while keeping an accurate cut. Cutting too slowly will waste blade life and lower production!
7. As the blade nears the end of the log, slow down the feed rate. When the teeth exit the end of the log, stop the carriage. Disengage the clutch/brake lever (or autoclutch blade switch). Remove the slab that has just been cut from the log.
8. Use the carriage forward/reverse switch to return the carriage to the front of the mill.
9. Repeat until the first side of the log is cut as desired. Set aside the usable flitches (boards with bark on one or both sides). They can be edged on the mill later.
10. Lower the toe boards, if they were used.
11. Remove the clamp and turn the log 90 or 180 degrees. Make sure the flat on the log is placed flat against side supports if turned 90 degrees. Make sure it is placed on bed rails if turned 180 degrees. If the log was turned 90 degrees and toe boards are being used to compensate for taper in the log, raise the front or rear toe board again on the second side of the log until the heart is parallel with the bed.
12. Repeat the steps used to cut the first side of the log until the log is square. Cut boards from the remaining cant by adjusting the blade height for the thickness of boards desired.

Example: Remember that the blade cuts a 1/16 - 1/8" (1.6-3.2 mm) wide kerf. If 1" (25.4 mm) thick boards are desired, lower the carriage 1 1/16 - 1 1/8" (27-28.6 mm) for each board.

4.8 Edging

1. Raise the side supports to 1/2 the height of the flitches, or the boards that need to be edged.
2. Stack the flitches on edge against the side supports.
3. Clamp the flitches against the side supports halfway up the flitch height.

TIP: Wider flitches should be placed to the clamp side. When they are edged, flip them over to edge the second side without disturbing the other flitches or without having to pull them from the middle of the stack.

4. Adjust the blade height to edge a few of the widest boards.
5. Loosen the clamp and turn the edged boards over to edge the other side.
6. Repeat steps 2-4.
7. Loosen the clamp and remove the boards that have good clean edges on both sides.
8. Clamp the remaining flitches and repeat steps 2-5.

4.9 Optional Cutting Procedure for Super Series Mills

In order to achieve maximum production rates with Super Series mills, it may be desirable to leave the blade engaged when returning the carriage. (Normal operation procedures recommend disengaging the blade before returning the carriage for maximum blade life and fuel economy.)



DANGER! If leaving the blade engaged for maximum production rates, make sure the off-bearer stays out of the path of the blade. Failure to do so will result in serious injury or death.



CAUTION! If you choose to leave the blade engaged; raise the blade to clear the log before returning the carriage. Failure to do so may cause damage to the blade and/or sawmill.

4.10 Blade Height Scale

The blade height scale is attached to the carriage head frame. It includes:

- a blade height indicator
- an inch scale
- a quarter scale

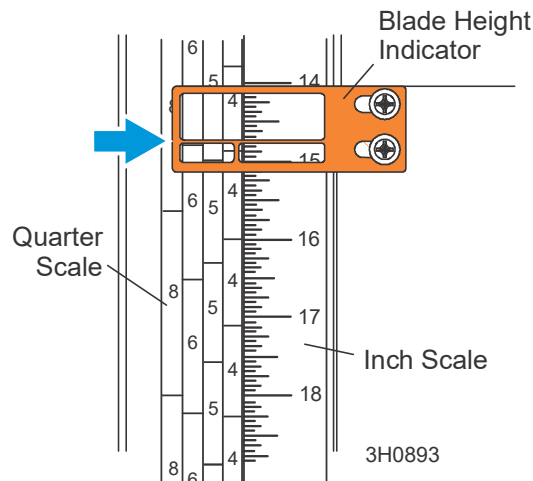

FIG. 4-12

The scales are attached to the frame and move up and down with the saw head. The blade indicator, used to read the inch and quarter scales, remains stationary.

THE INCH SCALE

The horizontal line on the blade height indicator shows how many inches the bottom of the blade is above the bed of the mill. Knowing the height of the blade at each cut, the thickness of lumber being sawed can be determined.

Example: 1" (25 mm) thick boards are wanted from random width boards from a log.

1. Position the blade for the first cut. Move the carriage to an even measurement on the inch scale.
2. Make a trim cut.
3. Return the carriage for the second cut and lower it 1 1/8" (29 mm) below the original measurement. (The extra 1/8" (3 mm) allows for saw kerf and shrinkage of the lumber.)

NOTE: The yellow area on the scale identifies where the blade could encounter a side support or log clamp.

4. Check that these items are below the blade level before sawing.

THE QUARTER SCALE

Two quarter scales are provided with four sets of marks. Each set represents a specific lumber thickness. Saw kerf and shrinkage allowance are included, but actual board thickness will vary slightly depending on blade thickness and tooth set.

To choose which scale to use, determine what finished thickness you want to end up with. The Grade Hardwood Quarter Scale provides thicker finished boards usually required by commercial buyers. The Standard Quarter Scale allows for kerf and shrinkage of finished boards suitable for most custom applications. Always check with your customer before you saw to determine what actual finished thickness is required.

Standard Quarter Scale	
Scale	Actual Board Thickness
4/4	1" (25 mm)
5/4	1 1/4" (32 mm)
6/4	1 1/2" (38 mm)
8/4	2" (51 mm)

Grade Hardwood Quarter Scale	
Scale	Actual Board Thickness
4/4	1 1/8" (29 mm)
5/4	1 3/8" (35 mm)
6/4	1 5/8" (41 mm)
8/4	2 1/8" (54 mm)

TABLE 4-1

To use the quarter scale, look at the blade height indicator.

Loosen the wing studs holding the quarter scale to the mast. Align the nearest mark on the scale you want to use with the blade height indicator. Tighten the wing studs.



CAUTION! Be sure to leave the wing studs in the vertical orientation to avoid interference with the blade height indicator. Failure to do so may result in damage to the indicator.

Make a trim cut. After returning the carriage for a second cut, lower the carriage to the next mark on the scale. This mark shows where the blade should be positioned to cut a certain thickness of lumber, without having to measure on the inch scale.

Example: 1" (25 mm) (4/4) thick boards are wanted from random width boards from a log.

1. Position the blade for the first cut.
2. Adjust the quarter scale so a 4/4 mark is aligned with the line on the indicator.
3. Make a trim cut.
4. Return the carriage for the second cut.
5. Now, instead of having to measure down 1 1/8" (29 mm) on the inch scale, lower the blade so the indicator is aligned with the next 4/4 mark on the quarter scale.
6. Turn the log 90 degrees and repeat.

4.11 Water Lube Operation

The Water Lube System keeps the blade clean. Water flows from a 5-gallon (18.9 liter) bottle through a hose to the blade guide where the blade enters the log. A valve in the bottle cap controls the amount of water flow.

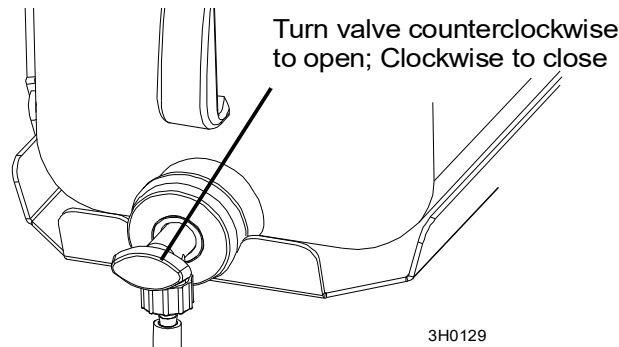

FIG. 4-13

A solenoid valve that will automatically start the water flow when the power feed is activated in the forward direction. The solenoid will stop the water flow when the feed switch is returned to the neutral position.

Not all types of wood require the use of the Water Lube System. When it is needed, use just enough water to keep the blade clean. This saves water, and lowers the risk of staining the boards with water. Usual flow will be 1-2 gallons (3.8-7.6 liters) per hour.

Before removing the blade, engage the blade. Let the blade spin with water running on it for about 15 seconds. This will clean the blade of sap buildup. Wipe the blade dry with a rag before storing or sharpening.

For further lubrication benefits, add one 12oz. (0.35L) bottle of Wood-Mizer Lube Additive to 5 gallons (18.9 liters) of water. Wood-Mizer Lube Additive enables some previously impossible timbers to be cut by significantly reducing resin buildup on the blade. It helps to reduce heat buildup, wavy cuts, and blade noise. This biodegradable and environmentally friendly pre-mix includes a water softener additive, so it works with hard water.



WARNING! Use **ONLY** water and Wood-Mizer Lube Additive with the water lube accessory. Never use flammable fuels or liquids such as diesel fuel. If these types of liquids are necessary to clean the blade, remove it and clean with a rag. Failure to do so can damage the equipment and may result in serious injury or death.



CAUTION! Use windshield washer fluid to the water tank and prime as recommended when sawing or storing the sawmill in below-freezing temperatures. Use windshield washer fluid with a freezing point of at least -20°F (-29°C). Failure to do so may cause damage to the LubeMizer system.

See the separate LubeMizer System manual for operation instructions.

4.12 Preparing The Sawmill For Towing

1. Move the saw carriage to the front end of the sawmill. Raise the rear outriggers.

CAUTION! Be sure the outrigger base is adjusted properly before securing the FAO in position with the lock pin. Failure to do so will cause damage to the outrigger grease fitting.

Do not adjust the FAO outrigger base height while there is weight on the FAO. Damage to the FAO may result.

2. If the sawmill is equipped with the optional hydraulic log turner, use the hydraulic control to raise the turner arm as high as it will go. Lift the turner arm up and place the travel plate under the turner to secure the arm above the sawmill bed.

CAUTION! Move the optional hydraulic turner to provide maximum ground clearance before towing. Failure to do so may result in damage to the sawmill.

3. If the sawmill is equipped with the optional hydraulic log loader, remove the loader retaining pins and use the hydraulic control to raise the loader as high as it will go. Place the retaining pins in the towing position holes and push the loader lever down to bring the loader arm channels up to the loader.

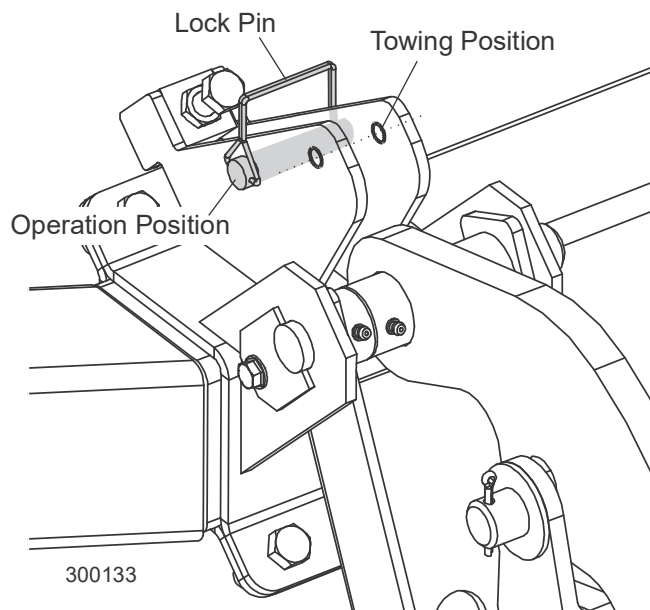
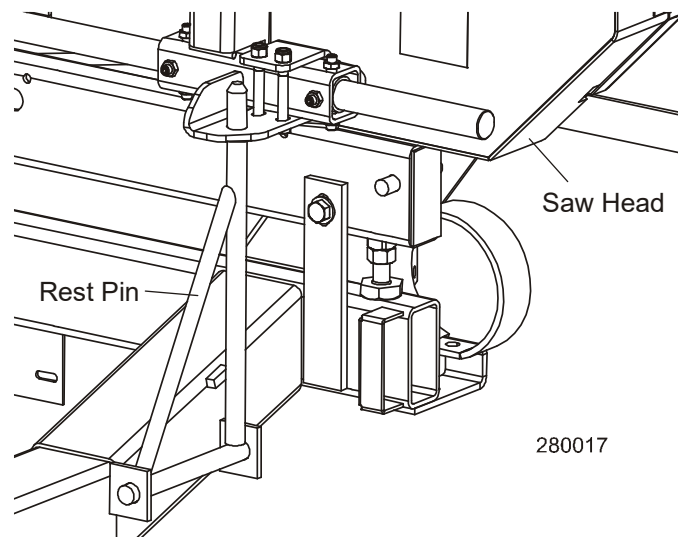

FIG. 4-14

4. Release the blade tension.

CAUTION! Changes in temperature could cause increased pressure in the blade tensioner and loss of fluid from the gauge. Release the blade tension when the mill is not in use to avoid damage to the tensioner.

5. Move the carriage forward to the travel position over the rear bed rail.
6. Position the hole in the saw head over the travel rest pin.
7. Lower the saw head until it is seated firmly on the rest pin.

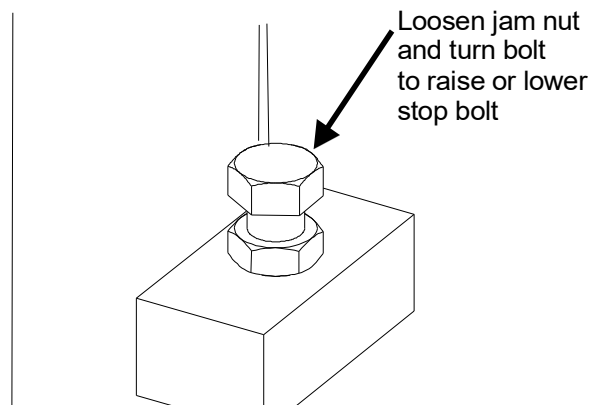

FIG. 4-15

8. Continue lowering the head 3/4" (19mm) until it contacts the stop blocks on the mast rails.



CAUTION! It is important that the lower stop bolts are properly adjusted to secure the carriage on the track rail. Failure to properly adjust the stop bolts can cause saw head damage, especially during mill transportation.

9. If necessary, adjust the stops located at the bottom of the mast so the saw head contacts them after it is lowered 3/4" (19mm) past where it contacts the rest pin.

FIG. 4-16

10. Engage the clutch/brake lever or autoclutch blade switch. This keeps the drive belt tight and the motor from bouncing while traveling.

NOTICE: Be sure to disengage the clutch/brake lever or autoclutch blade switch after reaching the destination to avoid deformation of the drive belt.

11. Hook the carriage safety chain located at the bottom of the carriage to the bracket at the bottom of the mast.

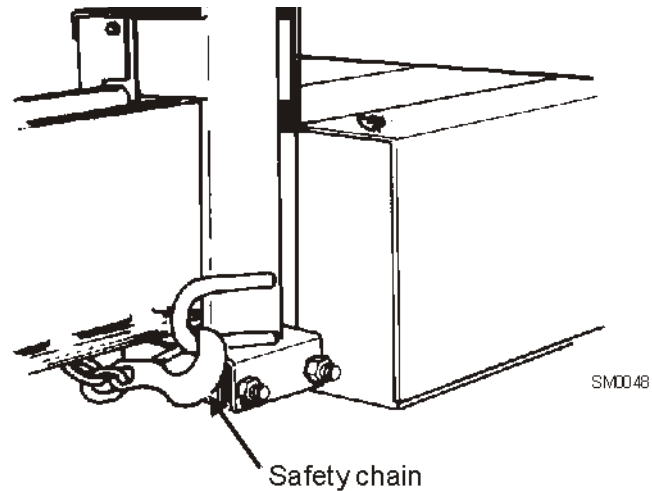

FIG. 4-17

12. Store the loading ramps on the bed rails. Secure to the bed with the two retaining brackets.



CAUTION! Check to be sure the saw head safety chain is secured before towing the sawmill. Failure to properly secure the saw head can result in severe machine damage. Be sure the blade housing and pulley covers are in place and secure. Use the safety retainer pin and cable to fasten blade housing covers.

13. Remove all loose objects from the bed of the mill. Store the outrigger jack handle in the bracket provided on the rear/loading-side outrigger guide. Reel in the winch cable and remove the winch handle.
14. Place both fenders in the slots located behind the trailer tires and secure with rubber straps. Raise all but the very front outrigger.

For Fine Adjust Outriggers (FAOs), be sure to adjust the outrigger base height so that the grease fitting is just below the lowest outrigger hole before securing the FAO in position with the lock pin.



CAUTION! Be sure the outrigger base is adjusted properly before securing the FAO in position with the lock pin. Failure to do so will cause damage to the outrigger grease fitting.

Do not adjust the FAO outrigger base height while there is weight on the FAO. Damage to the FAO may result.

See the trailer operator's manual for specific information regarding hitch operation and towing the sawmill.

SECTION 5 MAINTENANCE

This section lists the maintenance procedures that need to be performed.

See the [Maintenance Chart](#) located after this section for a complete list of maintenance procedures and intervals.

Keep a log of machine maintenance by recording in the machine hours and the date you perform each procedure.

Be sure to refer to option and engine manuals for other maintenance procedures.

5.1 Wear Life.

This chart lists estimated life expectancy of common replacement parts if proper maintenance and operation procedures are followed. Due to the many variables which exist during sawmill operation, actual part life may vary significantly. This information is provided so that you may plan ahead in ordering replacement parts

Part Description	Estimated Life
Up/Down Motor Brushes	1000 hours
B57 Blade Wheel Belts	400 hours
Up/Down Motor	2000 hours
Power Feed Motor Brushes	750 hours
Up/Down Drum Switch	1000 hours
Blade Guide Rollers	1000 hours
Power Feed Drum Switch	1200 hours
Power Feed Motor	1500 hours
Power Feed Belt	2000 hours
Up/Down Belt	2000 hours
Drive Belt	1250 hours

5.2 Blade Guides



WARNING! Before performing service near moving parts such as blades, pulleys, motors, belts and chains, first turn the key switch to the OFF (#0) position and remove the key. If the key is turned on and moving parts activated, serious injury may result.

Blade guide alignment is essential for optimal cutting performance, blade life, and safety. Failure to check and maintain proper blade guide alignment will result in stress cracks forming in the blade. These cracks will lead to premature blade breakage. If the blade breaks during operation and the blade has multiple stress cracks, the blade could shatter into several pieces and escape from the protective guards of the sawmill. Small blade pieces projected into the area around the sawmill creates a safety hazard for the operator and any bystanders surrounding the mill

1. Check the rollers for performance and wear every blade change.
2. Make sure the rollers are clean and spinning freely -- if not, replace them.
3. Replace any rollers which have worn smooth or have become cone shaped.

BLADE GUIDES EQUIPPED WITH OPTIONAL HIGH-PERFORMANCE ROLLER/BLOCKS ONLY:

4. Inspect the blocks at every blade change for damage or wear.
5. If the block housing is bent or damaged, replace the block assembly.
6. Replace the block assemblies before the blocks are worn to a point the blade may contact the lower step or housing.
7. Check the guide blocks with the provided shim or a feeler gauge **every 25 hours** of operation to ensure they are properly spaced (.008" - .010") from the blade.

NOTE: As the blocks wear, the front inside corner will wear more than the body of the block. When the corner wears far enough, sawing performance will be affected even if the body of the block is adjusted properly to the blade. At this point, the block should be replaced. If you have access to the appropriate equipment, you can grind or mill the blocks to a new flat surface and reuse them. It is recommended you develop a routine schedule for replacing the blade guide blocks based on your sawing conditions and experience.

8. Loosen the clamp bolt and mounting bolt to adjust the top block down.
9. Turn the adjustment bolt clockwise.
10. Retighten the mounting bolt and clamp bolt.
11. To adjust the bottom block up, loosen the clamp bolt and mounting bolt.
12. Use the provided adjustment tool to turn the adjustment screw clockwise.
13. Retighten the mounting bolt and clamp bolt.

NOTICE The blocks should be parallel to the blade. [See Section 7.2](#) for instructions about checking and adjusting the assembly level with the blade.

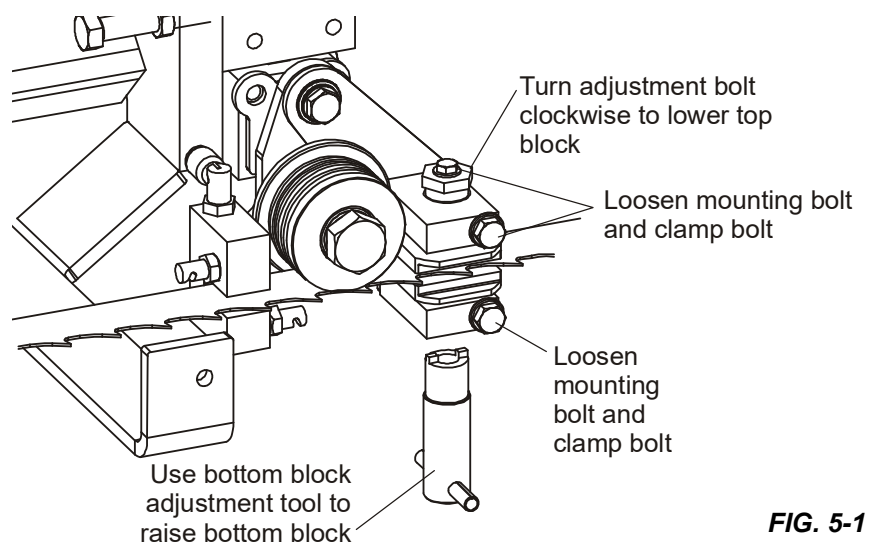

FIG. 5-1

Preventing sap buildup on the blade is critical when using the high-performance blade guide system. If the wood you are sawing leaves sap buildup using plain water in the blade lube system, use Wood-Mizer lube additive (4-Pak 60 oz. bottles part no. ADD-1).

14. Make sure the blade screw in the top center of the C-frame is $1/16"$ (1.5 mm) away from the blade; if not, loosen the nut and adjust the screw as necessary.
15. Check the screw **every 500 hours** of operation.

Failing to maintain this adjustment will lead to early blade breakage.

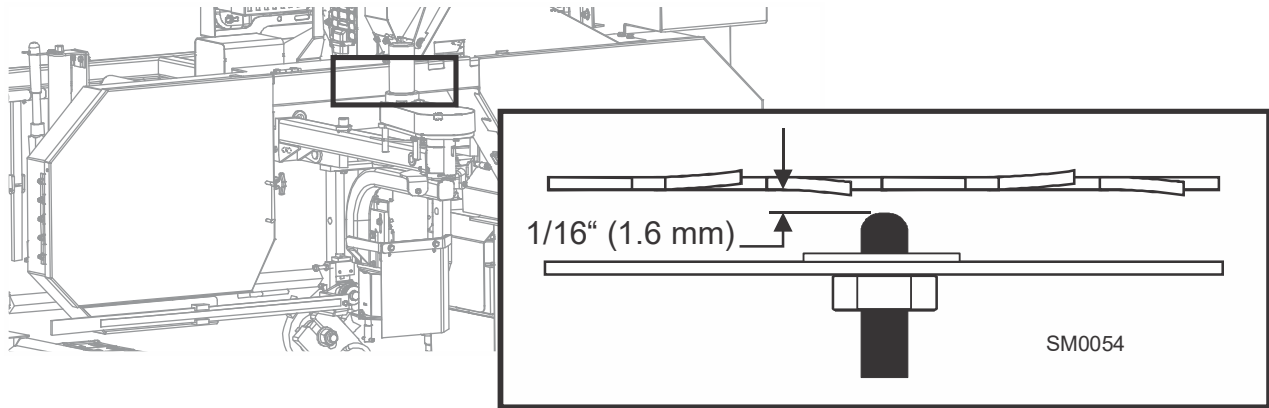

FIG. 5-2

5.3 Sawdust Removal



WARNING! Before performing service turn the key switch to the OFF (#0) position and remove the key.

Clean sawdust from all guards, vents, control boxes, or any area where sawdust may gather **after every shift**. Failure to do so **may result in fire**, causing death or serious injury.



Check the steel fingers inside the sawdust chute before operating the sawmill. The steel fingers have been designed to help prevent a broken blade or some other object from becoming a projectile and exiting the sawdust chute. Failure to have these fingers in place may result in serious injury.

Remove all sawdust and debris from around the velocity fuse valves **every 8 hours** of operation. The valves are located at the bottom of the optional log loader cylinders.

Remove sawdust buildup as necessary from the battery box lid and top rail cover.



CAUTION! Failure to remove sawdust buildup from the battery box lid and/or track rail cover could result in damage to these parts when the saw head is lowered to its lowest position.

As required, remove sawdust buildup from the power feed belt housing. Turn the control panel key switch to OFF (0) and remove the key. Disassemble the power feed belt cover and remove sawdust buildup in and around the power feed belt and pulleys. Replace the power feed belt cover.

5.4 Carriage Track, Wiper, & Scraper



WARNING! Before performing service near moving parts such as blades, pulleys, motors, belts and chains, first turn the key switch to the OFF (#0) position and remove the key. If the key is turned on and moving parts activated, serious injury may result.

Properly maintaining the sawmill carriage track is critical in preventing corrosion that can cause pitting and scaling on the rail surfaces. Pitted and scaled surfaces can, in turn, cause rough cuts or jerky feed movement.

1. Clean track rails to remove any sawdust and sap buildup every eight hours of operation.

Use a light-grade sandpaper or emery cloth to sand off any rust or other adhering particles from the rails.



CAUTION! Keep track rails free of rust. Formation of rust on the track rail in the areas where the cam bearings roll can cause rapid deterioration of the track rail's surface.

Lubricate the rails by wiping them with Dexron III ATF transmission fluid. Lubrication will help protect the rails from corrosive elements such as acid rain and/or moisture from nearby bodies of saltwater (if applicable). This lubrication is essential to maintain the integrity of the track rails and track rollers and to achieve long service life.

2. Remove sawdust from the track roller housings and lubricate the felt track wiper every twenty-five hours of operation.

Remove the track roller housing covers and brush any sawdust buildup from the housings.

Clean and lubricate the felt track wipers. Unbolt the track covers, remove from the sawmill and remove any sawdust buildup. Soak the felt wiper with Dexron III transmission fluid.



CAUTION! Reinstall the track wiper so that it lightly touches the track rail. If the wiper presses too firmly against the rail, it can cause the power feed to bind.

Soak the lower felt wipers with Dexron III transmission fluid. Apply oil to both wipers through the access holes in the wiper housings.

3. Check the track scrapers as needed. Make sure the scrapers fit firmly against the rail. If a track scraper needs to be adjusted, loosen the screw, push the scraper downward until it fits firmly against the rail, and retighten the screw.

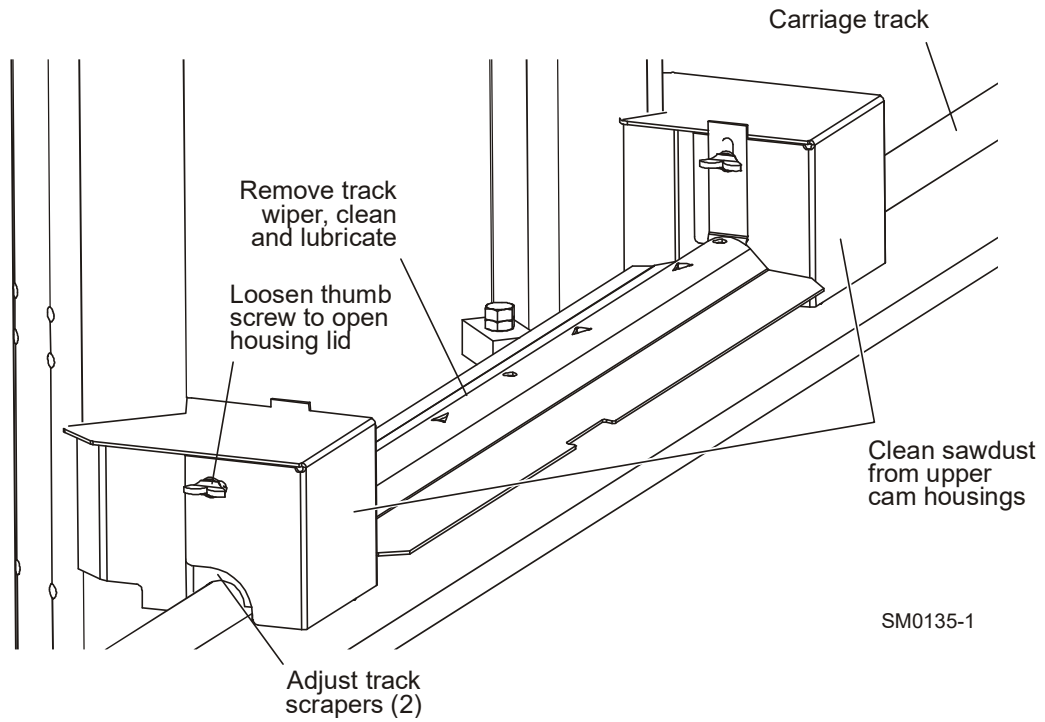

FIG. 5-3

5.5 Vertical Mast Rails



WARNING! Before performing service near moving parts such as blades, pulleys, motors, belts and chains, first turn the key switch to the OFF (#0) position and remove the key. If the key is turned on and moving parts activated, serious injury may result.

Clean the vertical mast rails **every 50 hours** of operation.



CAUTION! Never use grease on the mast rails as it will collect sawdust.

5.6 Drum Switches



WARNING! For battery-powered equipment, disconnect the negative battery terminal cable before performing any service to the electrical system.. For AC-powered equipment, follow the lockout procedure provided in the safety section. Failure to do so may result in injury and/or electrical system damage.

Lubricate the drum switch contacts inside the control panel **every 50 hours** of operation.

Use only contact grease supplied by Wood-Mizer.

Remove the control panel cover.

Use a cotton swab to apply grease to the switch contact ends.



WARNING! Drum switch grease contains Petroleum Hydrocarbon Lubricant. Eye and skin irritant. If introduced into eyes, flush with water for at least 15 minutes. Seek medical attention. Wash skin with soap and water. If ingested, do not induce vomiting - contact a physician. **KEEP OUT OF THE REACH OF CHILDREN.**

5.7 Miscellaneous

WARNING! Before performing service near moving parts such as blades, pulleys, motors, belts and chains, first turn the key switch to the OFF (#0) position and remove the key. If the key is turned on and moving parts activated, serious injury may result.

1. Oil all chains with Dexron III ATF **every 50 hours** of operation.

CAUTION! Do not use chain lube. It causes sawdust buildup in chain links.

2. Apply a thin film of a NLGI No. 2 grade lithium grease to the blade guide arm every 50 hours of operation to help prevent it from rusting.
3. Adjust the blade guide arm drive chain as necessary to prevent the arm from slipping. To adjust the chain, loosen the blade guide arm motor mounting plate bolts and slide the motor to take slack out of the chain.

Proper routing of the blade guide arm drive chain is shown below.

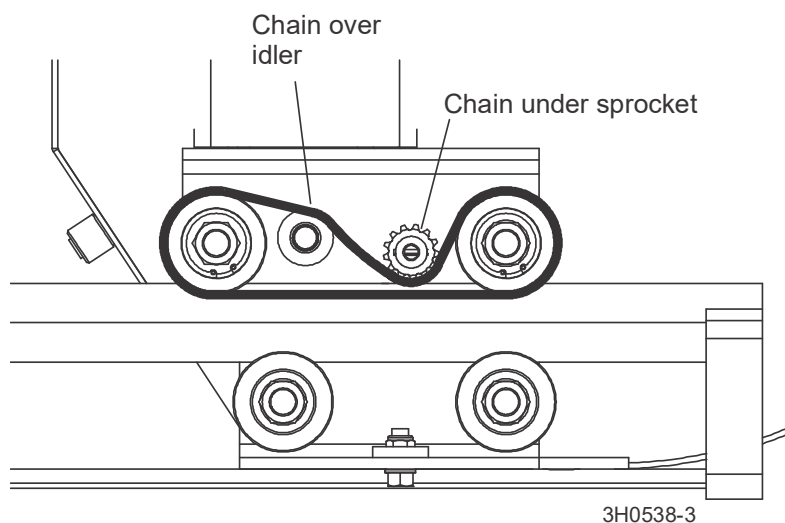

FIG. 5-3

4. Lubricate the log turner (if equipped) with a NLGI No. 2 grade lithium grease every 50 hours of operation. Lubricate the turner pivot pins with WD-40 or a dry lube.
5. Grease the optional loading arm, clutch handle pivot and side support pivots with a NLGI No. 2 grade lithium grease every 50 hours of operation.
6. Lubricate the board return pivot every 50 hours of operation with a NLGI No. 2 grade lithium grease. Apply grease to the grease fitting on the board return pivot tube.
7. Check the mill alignment every setup.
8. Remove sawdust and dirt from all safety warning decals; they must be readable.
9. Replace any damaged or unreadable decals immediately. Order decals from your Customer Service Representative.

5.8 Blade Tensioner



WARNING! Before performing service turn the key switch to the OFF (#0) position and remove the key. If the key is turned on and moving parts activated, serious injury may result.

1. Lubricate the chrome rods of the tensioner system with a heavy duty teflon spray lubricant, such as Gunk L508, **every 50 hours** of operation.
2. Lubricate the tensioner screw handle with a NLGI No. 2 grade lithium grease **as needed**.

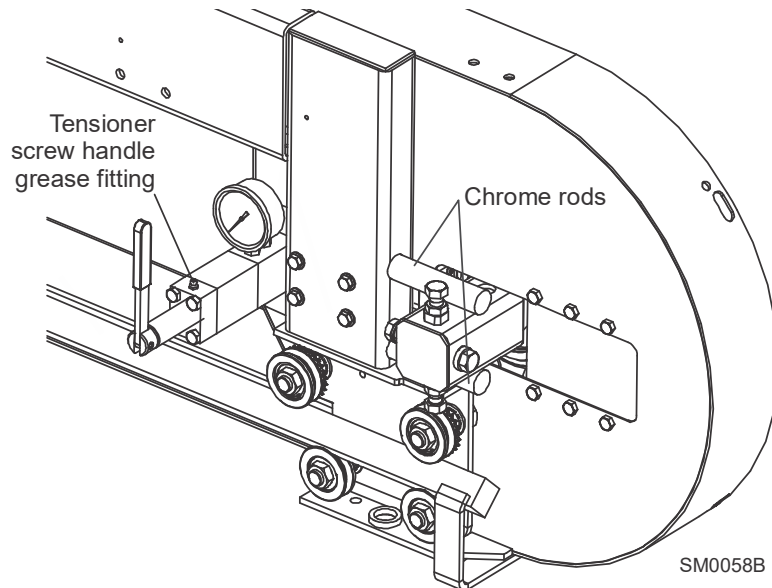

FIG. 5-4

Add an Automatic Transmission Fluid (ATF) such as Dexron III ATF to the hydraulic blade tensioner **as needed**. To add enough fluid to completely fill the tensioner block.

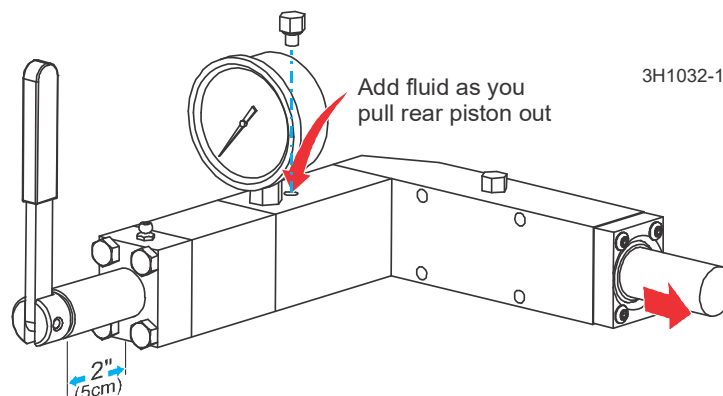

FIG. 5-5

1. Unscrew the tensioner handle to reveal 2" (50mm) of thread. Remove the sawmill blade housing covers and blade.
2. Push the idle-side blade wheel/shaft housing all the way in to collapse the rear tensioner piston.
3. Pull the idle-side blade wheel/shaft housing away from the tensioner.
4. There are two fill plugs provided on the tensioner; use the hole behind the gauge to refill the tensioner.

5. Clean any dirt and debris from the plug area.
6. Use a 7/16" wrench to remove the plug, making sure to keep the plug o-ring with the plug.
7. Use a small funnel, cup, or squirt can to add hydraulic fluid through the fill plug hole until a puddle of fluid forms and is maintained over the fill hole.
8. As you maintain the puddle, manually extend the rear piston.
9. Be careful not to draw air into the tensioner.
10. Use pliers to pull the rear piston if necessary, but only grip the outer 1/4" (6mm) of the rear piston.

Gripping or marring the surface beyond this point could result in seal damage and prevent the system from holding tension.

11. Continue pulling out the piston as far as it will travel.
12. Reinsert the plug and thread 2-3 turns.
13. Turn the tension handle clockwise until 6 or 7 threads show beyond the front piston block.
14. Tighten the plug all the way.
15. Push the idle-side blade wheel/shaft housing all the way in to collapse the rear tensioner piston.
16. If the piston does not extend at least 2" from the end of the tensioner block, repeat Steps 1-5.
17. Reinstall the blade and blade housing covers.
18. If you have trouble installing a blade, it may be necessary to remove some fluid.

Open the plug one turn and turn the tension handle in until some fluid is pushed out. Tighten the plug and retry.

5.9 Blade Wheel Belts



WARNING! Before performing the key switch to the OFF (#0) position and remove the key. If the key is turned on and moving parts activated, serious injury may result.

1. Rotate the blade wheel belts **every 50 hours** and check them for wear.

NOTE: Rotating the belts will provide longer belt life.

2. Replace belts as necessary.
3. Use only belts supplied by Wood-Mizer.

5.10 Brake Strap Adjustment



WARNING! Before performing service near moving parts such as blades, pulleys, motors, belts and chains, first turn the key switch to the OFF (#0) position and remove the key. If the key is turned on and moving parts activated, serious injury may result.

Check the brake strap for wear every 200 hours of operation. Replace if damaged or worn.

Also check and adjust the brake strap after each drive belt adjustment, if the blade does not stop quickly, or unusual sounds occur when the brake is applied, or a sudden change is noticed in the clutch handle position when the clutch is disengaged. Adjust the brake strap if the drive belt jumps from the drive pulley when the clutch handle is disengaged.

1. To access the brake strap, remove the belt cover located underneath the engine.
2. Engage the clutch/brake lever.

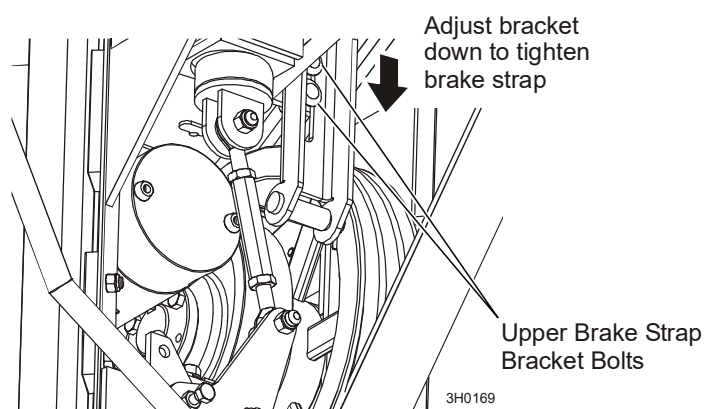

FIG. 5-6

3. Loosen the two nuts on the upper brake strap bracket. Slide the bracket and brake strap down 1/8" and retighten the bracket nuts.
4. Disengage the clutch. Check the drive belt fit in the drive pulley. You should just be able to pull the belt from the pulley. If the belt is still too loose, engage the clutch and repeat brake strap adjustments in 1/8" increments until the drive belt properly fits in the drive pulley with the clutch disengaged.

NOTE: Be careful to not overtighten. Overtightening will cause the drive belt to "grab" the pulley and can prevent the engine from starting properly.

Replace the belt cover.

5.11 Drive Belt Adjustment



WARNING! For battery-powered equipment, disconnect the negative battery terminal cable. For AC-powered equipment, follow the lockout procedure provided in the safety section.

Before performing service turn the key switch to the OFF (#0) position and remove the key. If the key is turned on and moving parts activated, serious injury may result.

Do not adjust the engine drive belts or belt support bracket with the engine running.



CAUTION! Do not over-tighten the drive belt. Damage to the engine may result

Engine	New Belt Installation/New Sawmill Operation				Subsequent Adjustment		
	Deflection Inches (mm)	Installation Force lbs. (kg)	Check After First	Acceptable Force lbs. (kg)	Check Every	Deflection Inches (mm)	Force lbs. (kg)
ALL	7/16" (11mm)	18 lbs. (8.16kg)	5 hrs	18 lbs. (8.16kg)	50 hrs	7/16" (11mm)	18 lbs. (8.16kg)

TABLE 5-2

1. Remove the two belt covers located underneath the engine.
2. Loosen the drive belt turnbuckle jam nuts. Turn the turnbuckle counterclockwise (as viewed from the top) to tighten the belt.

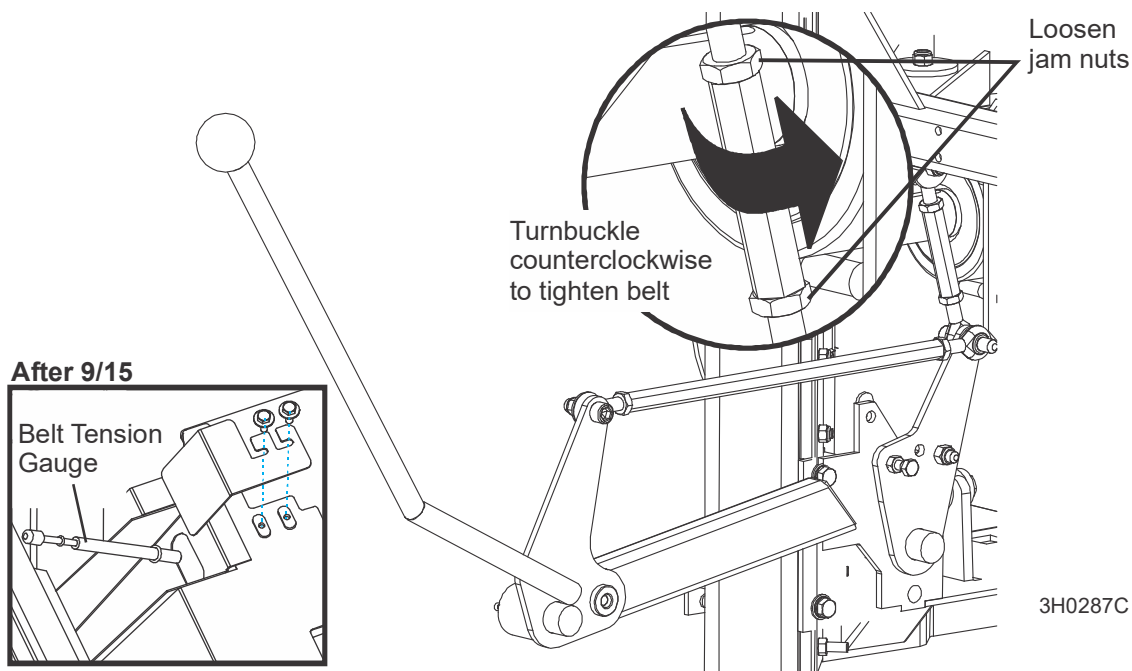

FIG. 5-7

3. Place a wrench on the flats at the top of the turnbuckle. Use a second wrench to turn the bottom-most jam nut clockwise (as viewed from the bottom) to tighten the belt.
4. Disengage the clutch/brake lever and check the fit of the belt in the drive pulley.

NOTE: You should just be able to pull the belt from the drive pulley. If the belt is too loose, it may jump from the drive pulley when the belt is disengaged. Adjusting the brake strap controls the drive belt fit in the drive pulley when the clutch/brake lever is disengaged ([See Section 5.10](#)).

Periodically check the drive belt for wear and replace any damaged or worn belts **as needed**.

Measure the belt tension with a gauge **every 50 hours** of operation..

1. Tension the drive belt by engaging the clutch.
2. Use a tension gauge to measure the drive belt tension.

NOTE: Wood-Mizer offers a belt tension gauge (Part No. 016309) that accurately measures the belt tension.

3. Zero out the pounds indicator by sliding the small O-ring against the yellow flange.
4. Open the belt cover.
5. Lay a straight edge across the two pulleys.
6. Set the large O-ring to the measurement on the chart.
7. Center the gauge in the middle between the two pulleys.
8. Press down on the rubber boot while the bottom of the gauge is against the drive belt.
9. Stop pressing when the large O-ring meets the straight edge.
10. Read the pounds indicated by the small O-ring.

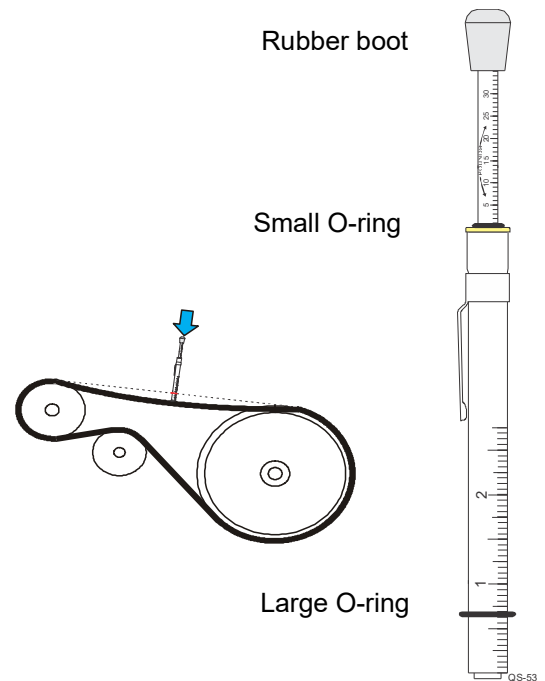

ADJUSTING THE DRIVE BELT

1. Remove the two belt covers located underneath the engine.
2. Loosen the jam nut at the bottom of the turnbuckle.
3. Turn the hex on the inner link rod clockwise (as viewed from the bottom) to tighten the belt, counterclockwise to loosen the belt.
4. If you reach the maximum adjustment using the bottom jam nut/inner link rod, adjust the linkage by loosening the top jam nut and turning the turnbuckle clockwise as viewed from the top.

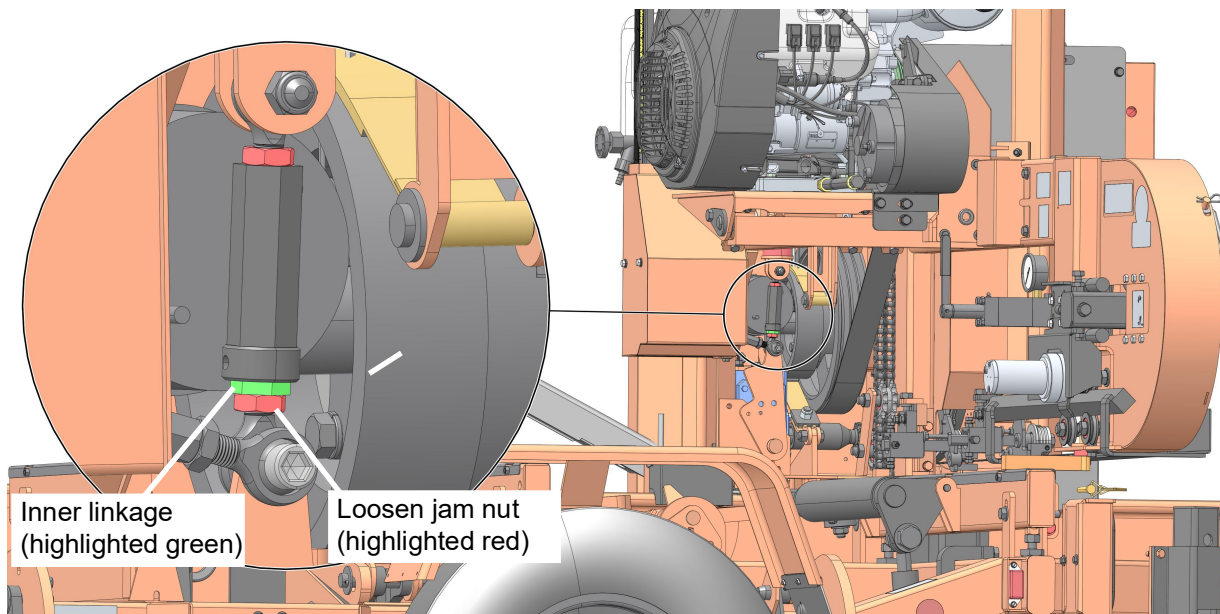

G38 ENGINE SHOWN

FIG. 5-8

5. Check all belts for wear; replace any damaged or worn belts **as needed**.
6. **Gas/Diesel Engines Only:** After tensioning the drive belt, check throttle cable tension and adjust if necessary.

The throttle cable should be tensioned just enough so that the engine revs as soon as the autoclutch is engaged. The throttle linkage should NOT affect engine RPM while the autoclutch handle is disengaged.

NOTE: A properly adjusted throttle will extend the cable spring 1/4" to 3/8" (6.4 - 9.5 mm) when running and have a slight amount of slack in the cable when idling. Check the drive belt support after adjusting drive belt tension.

Adjust the drive belt support

The drive belt support is designed to extend belt life. The bracket should be adjusted to NOT touch the drive belt when the clutch handle is engaged (down position), AND to hold the drive belt away from the engine pulley when the clutch handle is disengaged (up position).

Adjust the drive belt support as needed. Depending on your engine model, the drive belt support may be located near the drive wheel or drive pulley.

1. Ensure the power is off.

NOTE: Depending on your engine model, you will have one or the other style of belt support bracket.

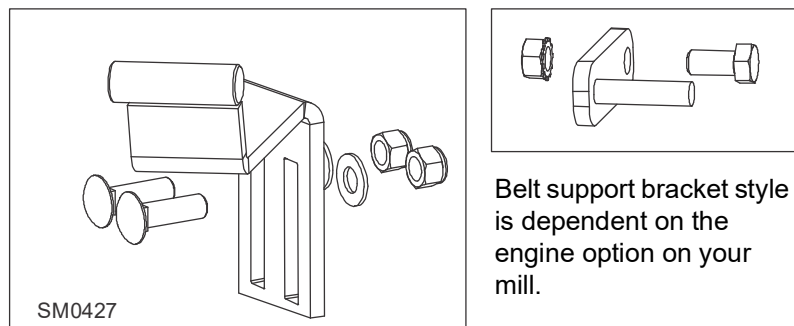

FIG. 5-9

2. Loosen the adjustment bolt.
3. Position the bracket so that the rod is close to, but does not touch, the drive belt with the clutch handle engaged. This is approximately 1/8-1/16" (3-1.5mm).
4. Retighten the adjustment bolt 25-27 pound feet (34-37 newton meters).

5.12 Drive Bearing



WARNING! Before performing service turn the key switch to the OFF (#0) position and remove the key. If the key is turned on and moving parts activated, serious injury may result.

Drain and refill the fluid in the drive-side cylinder bearing housing **every 500 hours** of operation.

1. Disconnect the oil level view hose from the fitting at the top of the bearing housing.
2. With the fitting at the bottom of the bearing housing still connected, allow oil to drain from the oil level view hose.
3. Once drained, pour fresh Automatic Transmission Fluid (ATF) such as Dexron III ATF into the hose until the oil level is in the acceptable range as indicated on the gauge decal.
4. Reconnect the hose to the top fitting.

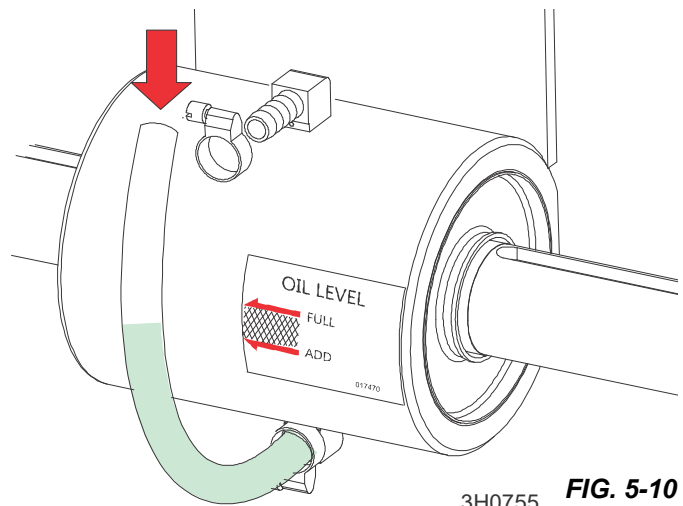

5.13 Up/Down System



WARNING! Before performing service near moving parts such as blades, pulleys, motors, belts and chains, first turn the key switch to the OFF (#0) position and remove the key. If the key is turned on and moving parts activated, serious injury may result.



WARNING! Disconnect and lockout power before performing any service to the electrical system. For battery-powered equipment, disconnect the negative battery terminal cable. Failure to do so may result in injury and/or electrical system damage.

1. Adjust the up/down chain tension as needed. Measure chain tension with the head all the way to the top of the vertical mast. Secure the head with a chain at the top. Find the chain adjusting bolt at the bottom of the mast. Use the adjustment nut to adjust the bolt until the center of the chain can be deflected $3/4$ " (1.9cm) forward *and* $3/4$ " (1.9cm) backward with a 5 lb. (2.3 Kg) deflection force.



WARNING! Always secure the saw head with a $5/16$ " chain with at least 1900 lbs. working load capacity before adjusting the up/down chain. The saw head may fall, causing severe injury or death.



CAUTION! Do not over-tension the chain. Over-tensioning the chain may lead to early failure of the gear reducer.

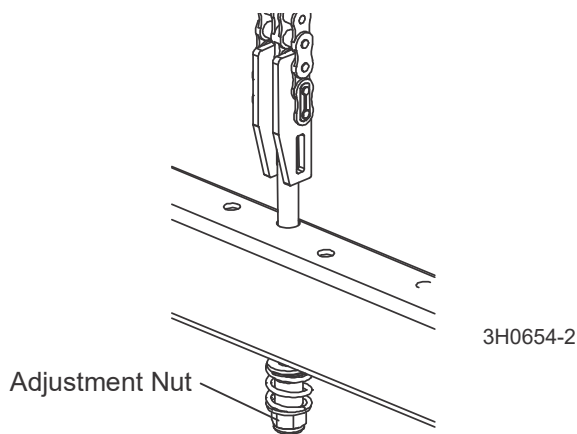

FIG. 5-11

1. Grease the up/down gear reducer shaft bearing with a NLGI No. 2 grade lithium grease every 1000 hours of operation.

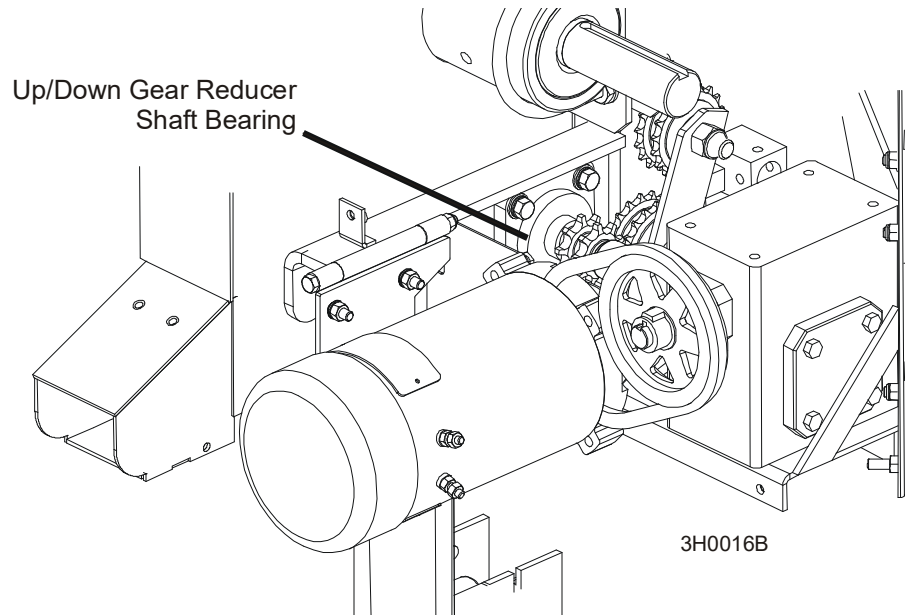

FIG. 5-12

2. The up/down motor features a spring-loaded belt design. Belt tension is automatically maintained and requires no adjustment. Replace the belt when adequate belt tension can no longer be obtained.



WARNING! Always secure the saw head with a 5/16" chain with at least 1900 lbs. working load capacity before removing the up/down motor belt. The saw head may fall, causing severe injury or death.

Periodically check the belt for wear. Replace any damaged or worn belts as needed.

3. Check the up/down gearbox oil level. Add a synthetic gear oil such as Mobil Glygoyle 460 as needed.

Drain and refill the gearbox with 24 (0.7L) ounces of oil after every 5000 hours of sawmill operation or every 2 years, whichever comes first.

Wood-Mizer offers replacement gear oil in 8 ounce (0.24L) bottles.

4. Inspect the up/down motor brushes every 750 hours of operation. Remove brush dust and replace the brushes if they worn to a length of 5/8" (16mm) or shorter.



CAUTION! Do not operate the up/down system if the motor brushes are worn shorter than 5/8" (16mm). Damage to the up/down motor may result.

5.14 Power Feed



WARNING! Before performing service near moving parts such as blades, pulleys, motors, belts and chains, first turn the key switch to the OFF (#0) position and remove the key. If the key is turned on and moving parts activated, serious injury may result.



WARNING! Disconnect and lockout power before performing any service to the electrical system. For battery-powered equipment, disconnect the negative battery terminal cable. Failure to do so may result in injury and/or electrical system damage.

1. Adjust the power feed belt as needed. When the power feed belt gets loose, it will begin slipping. This causes the carriage to not move forward when cutting. To retighten the belt:

Remove the four cover bolts and belt cover and measure the belt tension. The belt should be tightened so there is 1/8" (3 mm) deflection with a 7 lb. (3.2 Kg) deflection force. To adjust the belt tension, loosen the four motor mount bolts. Place a wrench on the jam nut and turn the adjustment bolt clockwise to tighten the belt. Retighten the motor bolts and replace the feed motor cover.

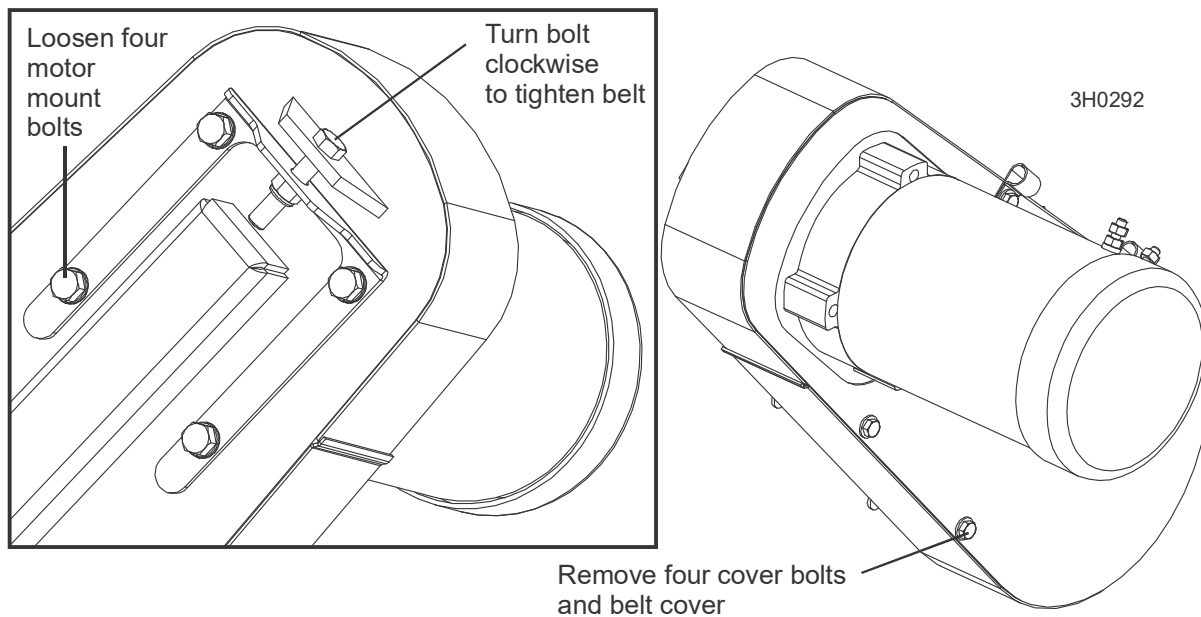



FIG. 5-13

Periodically check the belt for wear. Replace any damaged or worn belts as needed.

2.  Adjust the power feed chain as needed. Measure the power feed chain tension with the saw head all the way toward the front of the mill. Use the two lock nuts at the rear of the mill to tighten or loosen the power feed chain. Adjust the chain until it measures 7 to 8 inches (17.8 to 20.3 cm) from the top of the top rail at its lowest point.



CAUTION! Do not overtighten the feed chain. Damage to the power feed motor may result.

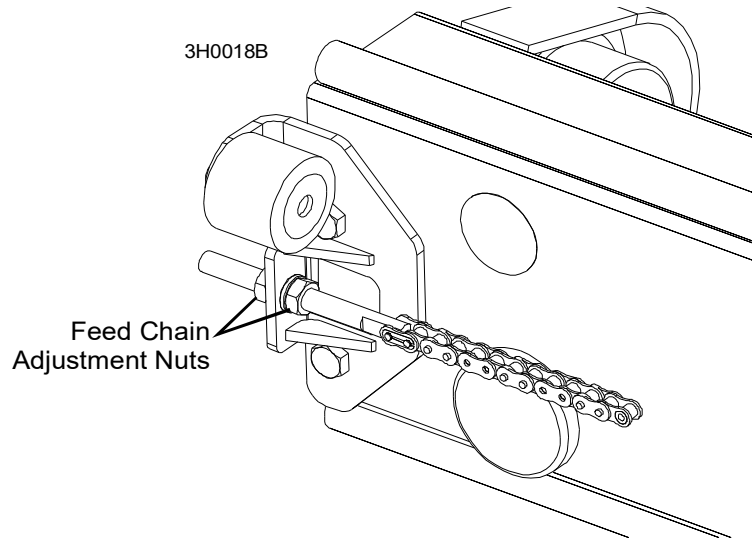

FIG. 5-14

Refer to the diagram for power feed chain routing instructions.

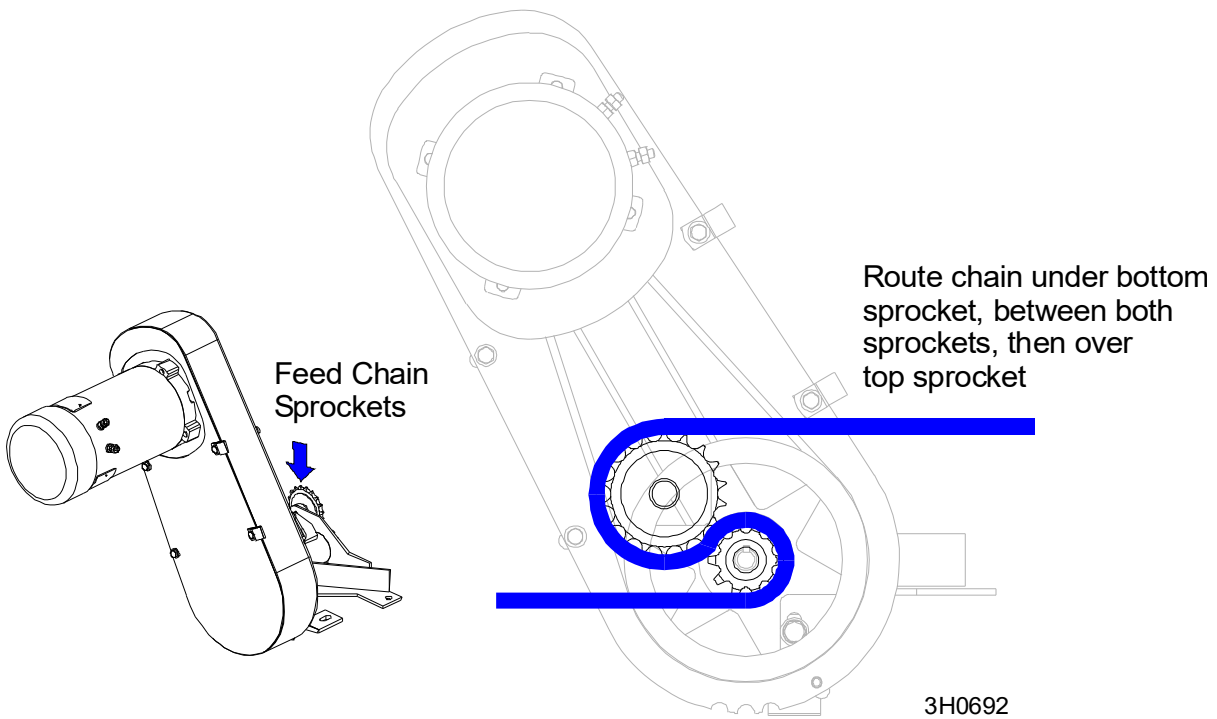

FIG. 5-15

3. Inspect the power feed motor brushes every 750 hours of operation. Remove brush dust and replace the brushes if they worn to a length of 5/8" (16mm) or shorter.



CAUTION! Do not operate the power feed system if the feed motor brushes are worn shorter than 5/8" (16mm). Damage to the feed motor may result.

5.15 Charging the Battery



DANGER! Batteries expel explosive gases. Keep sparks, flames, burning cigarettes, or other ignition sources away at all times. Always wear safety goggles and a face shield when working near batteries. Failure to do so will cause serious injury.



WARNING! Battery posts, terminals and related accessories contain lead and lead compounds, chemicals known to the State of California to cause cancer and reproductive harm. Wash hands after handling.

Charge the battery in a well ventilated area. Do not attempt to charge a frozen battery.

Use extreme care to avoid spilling or splashing electrolyte (which is dilute sulfuric acid) as it can destroy clothing and burn the skin.

EMERGENCY TREATMENT FOR CONTACT WITH BATTERY COMPONENTS (LEAD/SULFURIC ACID) per SDS (Safety Data Sheet):

EYE CONTACT	Sulfuric Acid and Lead: Flush eyes immediately with large amounts of water for at least 15 minutes while lifting lids. Seek immediate medical attention if eyes have been exposed directly to acid.
SKIN CONTACT	Sulfuric Acid: Flush affected area(s) with large amounts of water using deluge emergency shower, if available, shower for at least 15 minutes. Remove contaminated clothing, including shoes. If symptoms persist, seek medical attention. Wash contaminated clothing before reuse. Discard contaminated shoes. Lead: Wash immediately with soap and water.
INGESTION	Sulfuric Acid: Administer large amounts of water. Do NOT induce vomiting or aspiration into the lungs may occur and can cause permanent injury or death; consult physician.
INHALATION	Sulfuric Acid: Remove to fresh air immediately. If not breathing, give artificial respiration. If breathing is difficult, give oxygen. Consult a physician. Lead: Remove from exposure, gargle, wash nose and lips; consult physician.

If electrolyte is spilled or splashed on any surface of the machine, it should be neutralized and rinsed with clean water.



CAUTION! Do not overcharge the battery. Overcharging may reduce the overall service life of the battery.

Be sure the battery is fully charged before transporting the sawmill. If the battery is not fully charged, excessive vibration could reduce the overall service life of the battery.

1. Raise the saw head to access the battery box.
2. Turn the key to the OFF (#0) position and remove the key.
3. Remove the battery box lid.
4. Clean the battery terminals if necessary.
5. Connect the positive charger/jumper cable directly to the positive battery terminal.

6. Connect the negative charger/jumper cable to a grounded metal surface.
7. Follow the instructions supplied with your specific battery charger.

NOTICE Do not overcharge the battery, especially when using a high-rate or “boost” charger (40 amps or higher). These are intended to quickly charge a good battery that is discharged. They are not intended for unattended or long-term charging.

8. After the battery is completely recharged, remove the negative charger/jumper cable from ground.
9. Remove the positive charger/jumper cable from the battery.
10. Replace the battery box lid.

5.16 Hydraulic System (Optional Log Loader/Turner)



WARNING! Disconnect and lockout power before performing any service to the electrical system. For battery-powered equipment, disconnect the negative battery terminal cable. For AC-powered equipment, follow the lockout procedure provided in the safety section ([See Section 2.2](#)). Failure to do so may result in injury and/or electrical system damage.

1. Check the hydraulic fluid level every fifty hours of operation. Add fluid as necessary. The level in the hydraulic pump should be 3/4" (19mm) from the top with all cylinders collapsed.

If humidity is a problem or the mill is used outside in humid weather, drain and replace two quarts (.95 liters) of fluid every six months. This will drain any accumulated water and help prevent pump failure due to water ingestion. It also will prevent excessive fluid wear and allow the fluid to maintain its hot end performance. If humidity is not a problem, drain and replace one gallon (3.8 liters) of fluid every year to prevent fluid wear.

If you are operating in temperatures -20° to 100° F (-29° to 38° C), use an all-weather hydraulic fluid such as Conoco MV32. For alternate fluids and/or other temperature ranges, refer to the chart below. Operating above the recommended temperature range of a fluid could result in excessive pump wear. Operating below the recommended temperature range could result in reduced hydraulic cylinder speed. To change fluid types, replace one gallon of the current fluid with one gallon of the alternate fluid.

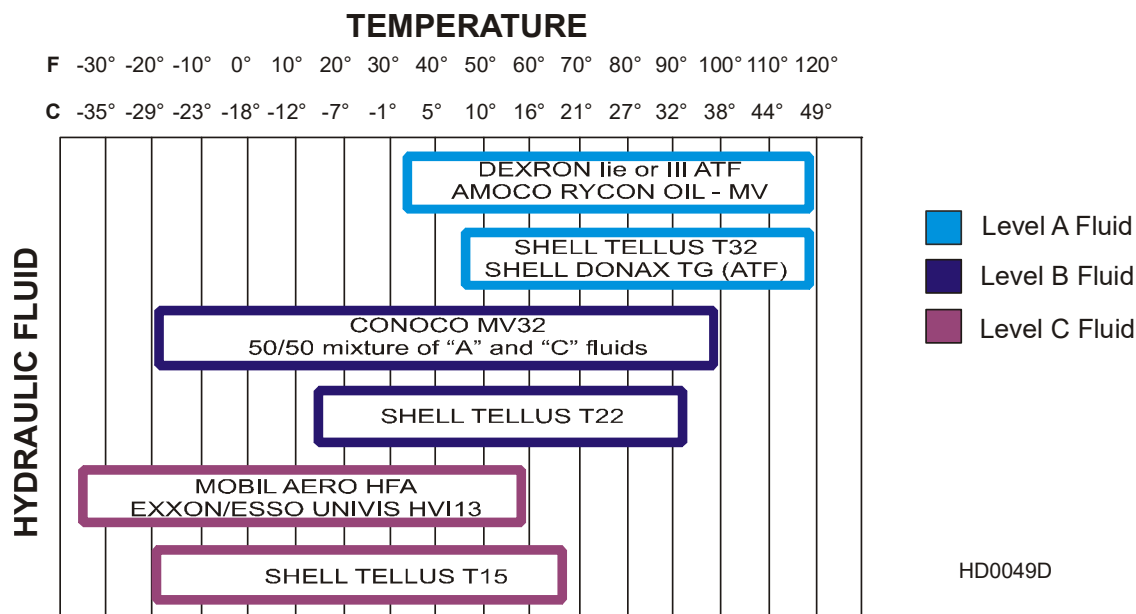

FIG. 5-16

2. Inspect the hydraulic pump motor brushes every 750 hours of operation. Remove brush dust and replace the brushes if they worn to a length of 1/4" (6mm) or shorter.



CAUTION! Do not operate the hydraulic system if the pump motor brushes are worn shorter than 1/4" (6mm). Damage to the pump motor may result.

3. Periodically check all hydraulic lines and fitting as needed. Replace as necessary.

5.17 Maintenance Chart

MAINTENANCE LOG (Check <i>Engine And Option Manuals</i> for additional maintenance procedures)	MANUAL REFERENCE	MAINTENANCE INTERVAL
Clean sawdust from hydraulic loader fuses(Optional), battery box lid & track cover	See Section 5.3	8 hours
Clean and lubricate top/bottom track	See Section 5.4	8 hours
Check blade guide Block/roller wear	See Section 5.2	8 hours Every blade change
Remove excess sawdust from blade wheel housings and sawdust chute	See Section 5.3	8 hours Every blade change
Inspect fingers inside sawdust chute	See Section 5.3	8 hours Every blade change
Remove sawdust from upper track roller housings	See Section 5.4	25 hours
Check Blade Guide Block Spacing	See Section 5.2	25 Hours
Clean and lubricate upper track wiper	See Section 5.4	25 hours
Clean & lube mast rails	See Section 5.5	50 hours
Lubricate drum switches	See Section 5.6	50 hours
Grease pivot points and bearings/oil chains	See Section 5.7	50 hours
Lubricate blade tensioner handle and rods	See Section 5.8	50 hours
Rotate drive/idle blade wheel belts/check for wear	See Section 5.9	50 hours
Inspect hydraulic lines & fittings (Optional Loader/Turner)	See Section 5.16	50 hours
Check belt tensions	See Section 5.11 See Section 5.13 See Section 5.14	50 hours
Check hydraulic fluid level (Optional Loader/Turner)	See Section 5.16	50 hours
Check feed & up/down chain tensions	See Section 5.13 See Section 5.14	50 hours
Check up/down gear box fluid level	See Section 5.13	50 hours
Check brake strap tension	See Section 5.10	200 hours
Re-check belt tensions	See Section 5.11 See Section 5.13 See Section 5.14	200 hours
Check blade throat screw	See Section 5.2	500 hours
Replace cylinder drive bearing fluid	See Section 5.13	500 hours
Inspect hydraulic pump (Optional Loader/Turner), power feed and up/down motor brushes	See Section 5.16 See Section 5.13 See Section 5.14	750 hours
Grease the Fine Adjust Outriggers (FAOs) every 200 hours of operation or once a month, whichever comes first.	See Section 5.18	200 hours
Grease up/down shaft bearing	See Section 5.13	1000 hours

SECTION 6 TROUBLESHOOTING GUIDE

6.1 Sawing Problems



WARNING! Before performing service near moving parts such as blades, pulleys, motors, belts and chains, first turn the key switch to the OFF (#0) position and remove the key. If the key is turned on and moving parts activated, serious injury may result.

PROBLEM	CAUSE	SOLUTION
Blades Dull Quickly	Dirty logs	Clean or debark logs, especially on entry side of the cut
	When grinding teeth, heating too much and causing teeth to soften	Grind just enough metal to restore sharpness to the teeth. Use water/coolant while sharpening blade
	Poor sharpening techniques	Make sure the tip is being sharpened completely (See Sharpener Manual)
Blades Break Prematurely	Poor sharpening techniques	See Sharpener Manual
	Rubber belts on blade wheels worn to a point that blade contacts metal pulley - look for shiny spots on edge of wheels	Change blade wheel belts (B-57)
Blade Does Not Track Right on Drive Wheel	Tension too tight	Tension blade to recommended specifications
	Cant adjustment is incorrect	Readjust
Blade Guides Do Not Spin While Cutting	Flat/worn belts	Replace B-57 belts
	Frozen bearings	Replace bearings
Blade Does Not Stop Immediately After Disengaging	Brake strap too loose	Adjust brake strap
Drive Belts Come Off Pulleys When Disengaging Blade	Brake strap too loose	Adjust brake strap
	Brake drum misaligned	Realign on drive shaft
	Brake strap tightened with one edge too loose and one edge too tight	Adjust brake strap
Drive Belts Wear Prematurely or Jump	Engine/motor and drive pulleys out of alignment	Align pulleys See Section 6.10.
Boards Thick Or Thin On Ends Or Middle Of Board.	Stress in log which causes log to not lay flat on the bed.	After log has been squared, take equal cuts off opposing sides. Take a board off the top. Turn the log 180 degrees. Take a board off. Repeat, keeping the heart in the middle of the cant, and making it your last cut.
	Set in teeth.	Resharpener and reset blade.
	Bed rails misaligned.	Realign sawmill.

PROBLEM	CAUSE	SOLUTION
Height Adjustment Jumps or Stutters When Moving Up or Down.	Up/down chain improperly adjusted.	Adjust up/down chain.
	Vertical wear pads are too tight.	Adjust pads.
	Up/down belt loose.	Replace belt.
Lumber Is Not Square	Vertical side supports not square to bed	Adjust side supports.
	Blade not parallel to bed rails	Adjust bed rails parallel to blade.
	Sawdust or bark between cant and bed rails	Remove particles
	Tooth set problems	Resharpener and reset blade
Sawdust Builds Up On Track	Excessive oiling	Do not oil track
	Track wipers worn	Adjust wipers to firmly contact track
	Track is sticky	Clean track with solvent and apply silicone spray
Wavy Cuts	Excessive feed	Slow feed rate
	Improperly sharpened blade (This will be the problem 99% of the time!)	Resharpener blade (See Sharpener Manual - read entire manual!)
	Blade guides improperly adjusted	Adjust blade guides.
	Sap buildup on blade	Use Water Lube.
	Tooth set problem	Resharpener and reset blade

6.2 Electrical Problems



WARNING! Before performing service turn the key switch to the OFF (#0) position and remove the key. If the key is turned on and moving parts activated, serious injury may result.

Disconnect and lockout power before performing any service to the electrical system. For battery-powered equipment, disconnect the negative battery terminal cable. For AC-powered equipment, follow the lockout procedure provided in the safety section ([See Section 2.2](#)). Failure to do so may result in injury and/or electrical system damage.

PROBLEM	CAUSE	SOLUTION
Up/down Excessively Slow.	Up/down belt loose.	Adjust belt to be as loose as possible without slipping.
	Vertical wear pads too tight.	Adjust pads.
Up/down Or Power Feed Motors Do Not Work.	Worn up/down motor or motor brushes.	Replace up/down motor or motor brushes.
	Worn/dirty contacts in drum switch.	Replace switch or remove control panel cover and clean contacts.
	Bad key switch.	Replace key switch.
	Circuit breaker.	Reset breaker in control box (See Section 6.3).
Power Feed Motor Does Not Work.	Burned-out motor.	Replace motor.
	Bad connection on battery post or loose wire.	Check for loose wire or terminal connections.
Power Feed Motor Does Not Work.	Sawdust buildup in the power feed pulleys.	Sawdust buildup puts mechanical bind on power feed which causes automatic motor protection circuit to activate. Remove sawdust from pulleys and operate normally. If motor does not operate after sawdust removal, reset circuit breaker on the front of the control box.
Up/Down Or Power Feed Switches Remain Engaged When Switch Is Released.	Worn/dirty contacts in drum switch.	Manually move the power feed or up/down switch back to neutral or "off" position. Replace drum switch or remove control panel cover and clean and lubricate contacts NOTE: Use only contact grease supplied by Wood-Mizer.
	Drum switch spring broken.	Manually move the power feed or up/down switch back to neutral or "off" position. Replace drum switch spring.
Up/Down Or Power Feed Motors Overheat And Lose Power.	System overload or bind occurred.	Correct problem (See Section 6.4). Allow motor to cool before restarting.
	Normal operation factors exceeded (eg: up/down control jockeyed excessively).	Allow motor to cool before restarting.
Everything Works And Then Cuts Out - Works Again.	Bad battery, fuse, or ground connection.	Check and tighten connections.
Nothing Works Electrically.	Dead battery.	Check for short circuit or turn OFF key.

PROBLEM	CAUSE	SOLUTION
	Blown fuse.	Replace.
	Corrosion on battery post.	Remove connection and clean posts.
Battery Will Not Stay Charged.	Key switch left ON.	Turn switch OFF when not in use.
	Short in system.	Visually check for bare wires and/or have checked.
	Charging system not functioning.	Have charging system checked by authorized dealer.
	Bad battery cells.	Check fluid levels and add proper solution
	Idle improper.	Adjust low end RPM per engine manual.
	Loose alternator belt.	Check belt tension and tighten if necessary.
	Loose connections at LED circuit board or alternator.	Check and tighten connections.
Intermittent Or Permanent Loss Of Accessory Motor Functions Occurs (Up/down, Fwd/rev, Blade Guide Functions Do Not Work).	Bad connections at accessory solenoid or bad solenoid.	Check all connections at accessory solenoid. If connections are good, replace solenoid.

6.3 Circuit Breaker Operation

Sawmill controls are equipped with manual reset circuit breakers to protect the electrical circuits.

The power feed and up/down breakers are externally mounted at the front of the control box. The blade guide, accessory, ignition, start and board return breakers are located inside the control box. Remove the circuit breaker panel from the control box to access the internal breakers.

NOTE: If the breaker is still hot, you may not be able to reset it immediately. Allow the breaker to cool for a few minutes before attempting to reset.

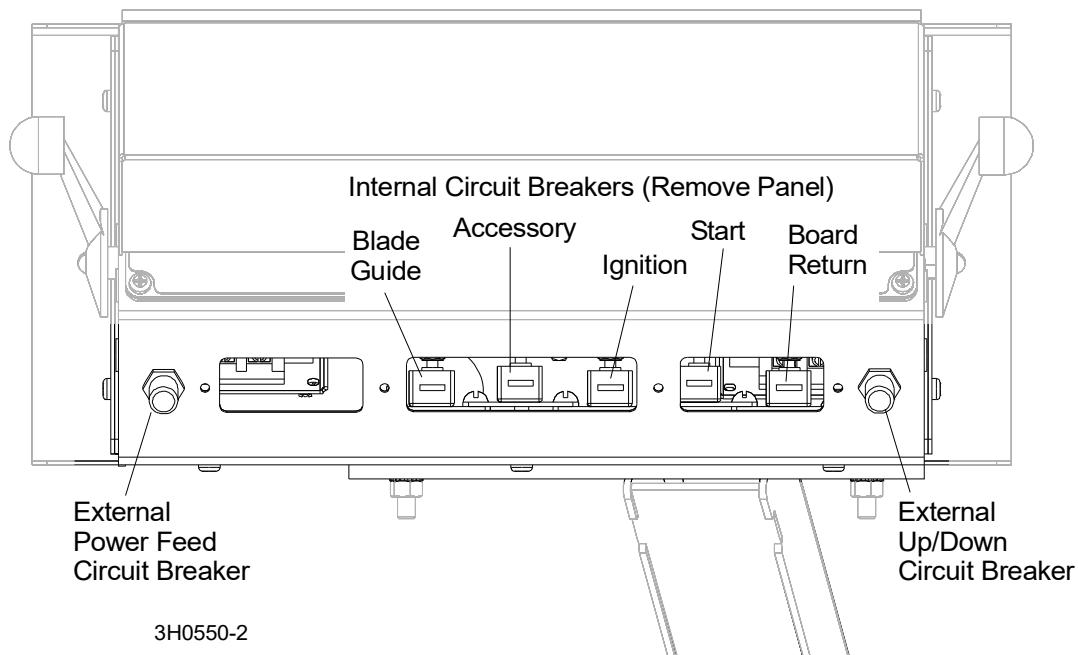

FIG. 6-1

6.4 Power Feed Problems



WARNING! Disconnect and lockout power before performing any service to the electrical system. For battery-powered equipment, disconnect the negative battery terminal cable. Failure to do so may result in injury and/or electrical system damage.

NOTE: The Dual-Axis Control is equipped with LED lights to help determine the cause of any feed problems you may encounter. If the sawmill is not equipped with Accuset, [See Section 6.5](#) for instructions. Otherwise, [See Accuset 2 option manual](#) for instructions.

PROBLEM	CAUSE	SOLUTION
Power Feed Is Jerky At Low Speeds Or Does Not Move Until Speed Is Above Halfway Mark.	Drum switch is dirty.	Clean drum switch and lubricate with contact grease supplied by Wood-Mizer.
	Drum switch contacts are bad	Check that contacts are in good condition and positively close circuit.
	Components are loose or wires are broken.	Replace or repair PC board.
Power Feed Is Jerky When Shaft Of Feed Rate Dial Is Moved Back And Forth.	Variable speed switch is bad - perform the variable speed switch test.	Replace variable speed switch.
Power Feed Is Jerky, But Power Feed Motor Runs Properly At All Speeds.	Problem is mechanical.	Refer to the Mechanical Test.
Power Feed Is Sluggish, Trips Circuit Breaker Or Current Limit.	Sawdust buildup in power feed cover.	Remove power feed belt cover and remove sawdust.
Power Feed Motor Overheats.	Middle track oiler is dragging.	Clean middle track oiler and lubricate with 30-weight oil or ATF (Automatic Transmission Fluid) such as Dexron II. Allow motor to cool before restarting.
	Ground is not level.	Level mill with carpenter's level. Allow motor to cool before restarting.
	Track roller bearing drag is excessive.	Lubricate bearings; Replace tight bearings. Allow motor to cool before restarting.
	Lower track rollers are not aligned properly.	Check stop clearance from lower track rail. Allow motor to cool before restarting.
	Chain is dragging.	Make sure chain is centered on idler; Clean and lubricate chain; Adjust chain tension. Allow motor to cool before restarting.
	Chain is improperly tensioned.	Adjust chain tension. Allow motor to cool before restarting.
	Operator Seat option load is excessive.	Check seat bearings for freedom of movement; Loosen clamping screw 1/4 turn. Allow motor to cool before restarting.
	Power feed is binding.	Adjust belt tension; Check condition of belt, pulleys, bearings, and sprocket; Check motor for ground fault. Allow motor to cool before restarting.

PROBLEM	CAUSE	SOLUTION
	Saw head load is excessive.	Avoid unnecessary modifications to saw heads that would give them extra weight. Allow motor to cool before restarting.
	Blade is dull or improperly set.	Use proper blade maintenance procedures (See Sharpener or Toothsetter manual). Allow motor to cool before restarting

6.5 Dual-Axis Motor Driver Module Troubleshooting

The motor driver module controls the power feed and the up/down operation.

NOTE: The motor driver module diagnostic lights behave differently if the sawmill is equipped with the Accuset 2 option. **The information below only applies to sawmills without Accuset.** If the sawmill is equipped with Accuset, [See Accuset 2 option manual](#) for instructions.

- When the saw head is in the neutral position, the Status light is solid green.
- When the power feed drum switch is moved to the reverse position, the switch input and motor output lights are green.
- With the power feed drum switch in the forward position, the switch input and motor output lights are red.
- If an error occurs, the status light will flash between green and red. This condition indicates a fault has occurred in the power feed system.

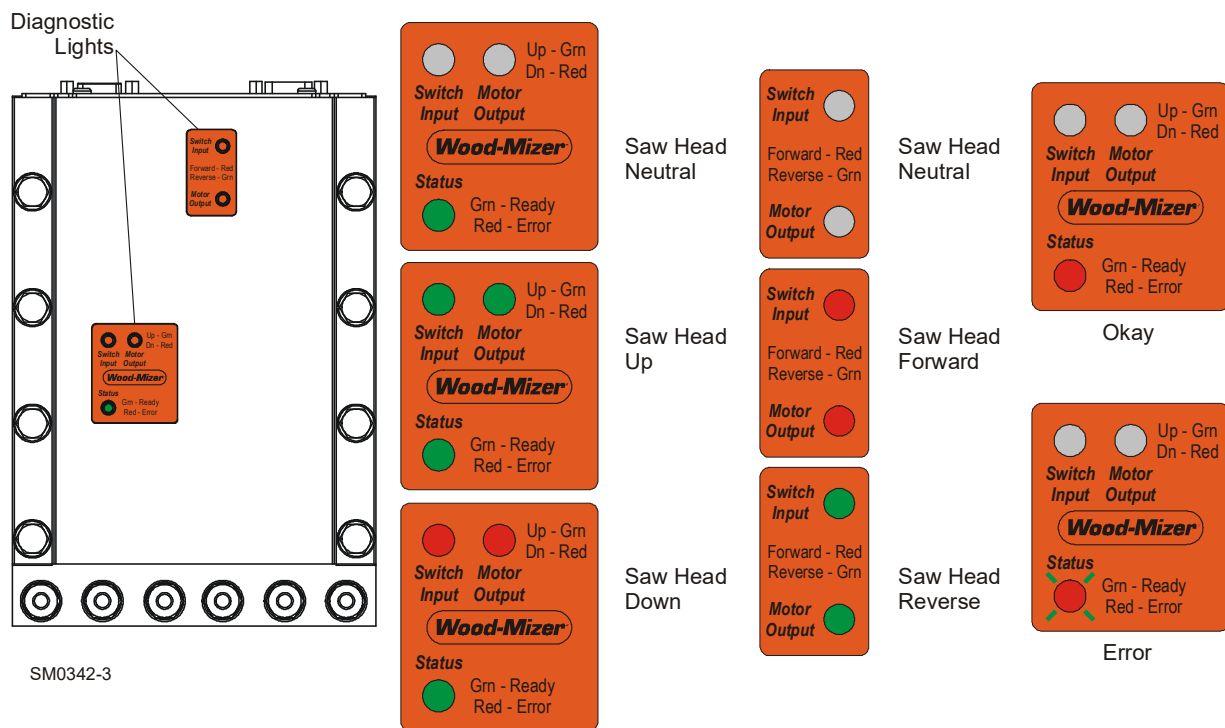

FIG. 6-2

6.6 Power Feed Variable Feed Rate Switch Test

With the feed rate dial switch all the way down, move the shaft of the dial back and forth to see if there is a jerky response. Turn the dial and move the shaft back and forth again. Repeat several times. If the jerkiness occurs at the same location on the dial several times, you need to replace the variable speed switch.

WARNING! Disconnect and lockout power before performing any service to the electrical system. For battery-powered equipment, disconnect the negative battery terminal cable. For AC-powered equipment, follow the lockout procedure provided in the safety section ([See Section 2.2](#)). Failure to do so may result in injury and/or electrical system damage.

6.7 Power Feed Preliminary Test

This test will determine if the problem is mechanical or electrical.

1. Remove the drive belt from the power feed drive pulley.
2. Turn the key switch to the ACC position. Put the carriage forward/reverse switch into the forward position and turn the feed rate dial through all speeds. If the power feed motor runs properly at all speeds, the problem is a mechanical one instead of an electrical one.

6.8 Power Feed Mechanical Test

1. Remove the weight from the track rollers. They should turn smoothly and easily with very little play.
2. Make sure the middle track cover is not bent or touching the top rail.
3. Make sure the middle track oiler is free of sawdust buildup.
4. Make sure the power feed chain is not stiff from rust. Also make sure the chain is not too tight.
5. Check the power feed shaft. Visually inspect the bearings. The shaft should move neither in or out nor side to side.
6. Make sure the power feed chain cam bearing is not touching the main frame tube.
7. Make sure there is no sap or rust on the rails.
8. Make sure the stop on the lower track roller assembly is not rubbing the lower rail. Also make sure the track rollers are not too tight.
9. Make sure the power feed belt is properly tightened.

6.9 Hydraulic Problems (Optional Log Loader/Turner)



WARNING! Disconnect and lockout power before performing any service to the electrical system. For battery-powered equipment, disconnect the negative battery terminal cable. For AC-powered equipment, follow the lockout procedure provided in the safety section ([See Section 2.2](#)). Failure to do so may result in injury and/or electrical system damage.

Before performing service turn the key switch to the OFF (#0) position and remove the key. If the key is turned on and moving parts activated, serious injury may result.

PROBLEM	CAUSE	SOLUTION
Any Hydraulic Handle Can Be Actuated, But No Response From The Pump.	Carriage not positioned properly to provide power to the pump	Make sure carriage contact bracket is adjusted far enough forward for battery positive contact to touch 6ft. strip on main tube. Check contact and strip for tarnish or loose wires. Clean as necessary
	Poor ground connection	Check ground connection between pump and saw frame and between battery negative contact and lower rail. Check contact and rail for tarnish or loose wires. Clean as necessary
	Blown fuse	Replace
	Low or dead battery	Test battery amperage capability (such as low battery charge, low alternator output, defective voltage regulator, bad battery cell, battery age deterioration, etc.). Replace or recharge as necessary
	Poor cable connection	Check cable connection and make sure that battery terminals are in good condition (not corroded)
No Response From The Pump By Actuating Handle	Defective solenoid (may be indicated by solenoid clicking) See Monarch manual for troubleshooting solenoid	After checking all other possibilities for low voltage to solenoid, check solenoid. Tapping on solenoid may fix temporarily. Replace solenoid if necessary. NOTE: The solenoid is not a standard automotive type. Order from Wood-Mizer only
	Defective pump motor	Remove motor from pump and inspect. Repair or replace as necessary
	Electric contact spring inside of non-working valve corroded, broken, or dislocated	Check contact spring. Relocate or replace as necessary
Pump Motor Runs With Little Or No Response From The Cylinders	Set screw holding handle to valve shaft is loose	Tighten set screw so that valve shaft turns when handle is actuated
	Low battery	Test battery. Recharge or replace as necessary

PROBLEM	CAUSE	SOLUTION
	Low fluid level	Check fluid level. Add an all-season hydraulic fluid such as Amoco Rycon Oil MV or Mobil Multipurpose ATF (automatic transmission fluid) until level is 4 - 4 1/2" (100 - 114mm) from bottom of reservoir with all cylinders retracted
	Pressure relief valve moved from proper setting	Adjust pressure relief valve.
	Low air temperature causing fluid to thicken	Allow fluid to warm up. Synthetic fluids are available that allow for hydraulic operation in cold weather conditions (Univis HVI 13)
Pump Motor Runs Continuously When Power Contact Is Made	Solenoid is stuck closed	Tapping the solenoid may solve this problem temporarily. Replace solenoid
	Valve handle spring is deformed or broken, causing the handle to not return to the neutral position	Replace handle spring
	Contact spring is dislocated and lying across contacts	Replace contact spring
Fluid Leaks From Around Cylinder Piston Ram	Worn seals	Replace seals in cylinder. Check piston ram for abrasive weld that may be causing premature seal failure
Fluid Leak Around Pump Box	Loose seal or fitting	Wipe pump off completely to locate cause of leak. You may have to unbolt the pump to wipe behind it. NOTE: Movement of the sawmill can cause fluid to slosh up into the foam filter in the reservoir cap, and subsequently spray out, giving the appearance that fluid is leaking from the pump
Hydraulic Side Supports Go Down Before Or At Same Time As Log Turner	Dirt in sequence valve	Remove sequence valves and clean thoroughly with kerosene. NOTE: Be sure to reassemble the valve and install it in its original position on the cylinder
	Retainer in sequence valve worn	Replace sequence valve
	Low air temperature causing fluid to thicken	Allow fluid to warm up. Synthetic fluids are available that allow for hydraulic operation in cold weather conditions (Univis HVI 13)
Hydraulic Turner Goes Up Before Or At Same Time As Side Supports	Dirt in sequence valve	Remove sequence valves and clean thoroughly with kerosene. NOTE: Be sure to reassemble the valve and install it in its original position on the cylinder

PROBLEM	CAUSE	SOLUTION
	Retainer in sequence valve worn	Replace sequence valve
	Low air temperature causing fluid to thicken	Allow fluid to warm up. Synthetic fluids are available that allow for hydraulic operation in cold weather conditions. (Univis HVI 13)
Pump runs but makes “growling” sound and hydraulic functions are slow, jerky or don’t work at all.	Low fluid level	Check fluid level and add fluid as necessary. Check for leaks in the system at the control box fittings, hoses and cylinders
A log loader cylinder does not move when lowering the loader causing the foot of other to raise completely before loader will start down.	Damaged cylinder shaft	Replace the cylinder that is not moving

6.10 Engine/Motor and Drive Pulleys Alignment



WARNING! Before performing service turn the key switch to the OFF (#0) position and remove the key. If the key is turned on and moving parts activated, serious injury may result.

Do not adjust the engine drive belts or belt support bracket with the engine running.

1. Install and properly tension the drive belt ([See Section 5.11](#)).
2. With the clutch handle disengaged, use a straight edge to check the alignment of the pulley on the engine/motor to the alternator pulley.
3. Loosen the bushing on the engine/motor pulley and adjust if necessary until it is aligned with the alternator pulley.
4. With the clutch handle disengaged, use a straight edge to check the alignment of the engine/motor pulley to the main drive pulley.
5. Loosen the bushing on the drive pulley and adjust if necessary until it is aligned with the engine/motor pulley.
6. **(E25 Only):** Check that the engine/motor pulley is also square with the drive pulley. If necessary, loosen the engine mounting bolts and cock the engine until the pulley is square with the drive pulley. Retighten the engine mounting bolts.
7. Check that all engine mounting bolts and pivot bushing clamps are tight.
8. Engage the clutch handle and recheck the pulley alignment. Adjust if necessary.
9. If any pulleys were adjusted, recheck the drive belt support(s) and adjust if necessary ([See Section 5.11](#)).

SECTION 7 SAWMILL ALIGNMENT

The Wood-Mizer sawmill is factory aligned. Two alignment procedures are available to realign the sawmill if necessary. The Routine Alignment instructions should be performed as necessary to solve sawing problems not related to blade performance. The Complete Alignment procedure should be performed approximately every 1500 hours of operation (sooner if you regularly transport the sawmill over rough terrain).

NOTE: THE PROCEDURES LISTED HERE MUST BE PERFORMED IN THE ORDER THEY APPEAR.

7.1 Routine Alignment Procedure

BLADE INSTALLATION

1. Remove the blade and check the blade wheel belts. Remove any sawdust buildup from the surface of the belts. Replace worn belts if they do not keep the blade from contacting the blade wheel.
2. Install a clean blade and apply the appropriate tension ([See Section 3.4](#)).
3. Inspect the optional blade guide blocks for damage or wear and replace as necessary. Check the blade guide blocks and drive side deflector plate are properly adjusted ([See Section 5.2](#)).
4. Adjust the idle-side cant control to track the blade ([See Section 3.5](#)).
5. Close the blade housing covers and make sure all persons are clear of the open side of the saw head.
6. Start the engine (or motor).
7. Engage the blade, rotating the blade until the blade positions itself on the wheels.



WARNING! Do not spin the blade wheels by hand. Spinning the blade wheels by hand may result in serious injury.

8. Disengage the blade.
9. Turn the engine off and remove the key.

SAW HEAD TILT

As the blade enters a wide log or cant, the outside of the saw head will drop down slightly. To compensate for the drop, the saw head is adjusted 1/16" (1.5 mm) higher at the outside.

1. Move the saw carriage so the blade is positioned over a bed rail. Adjust the blade guide arm to 1/2" (15 mm) from full open.
2. Raise the saw head so the bottom of the blade measures 14 3/4" (375 mm) from the top surface of the bed rail near the inner blade guide assembly.

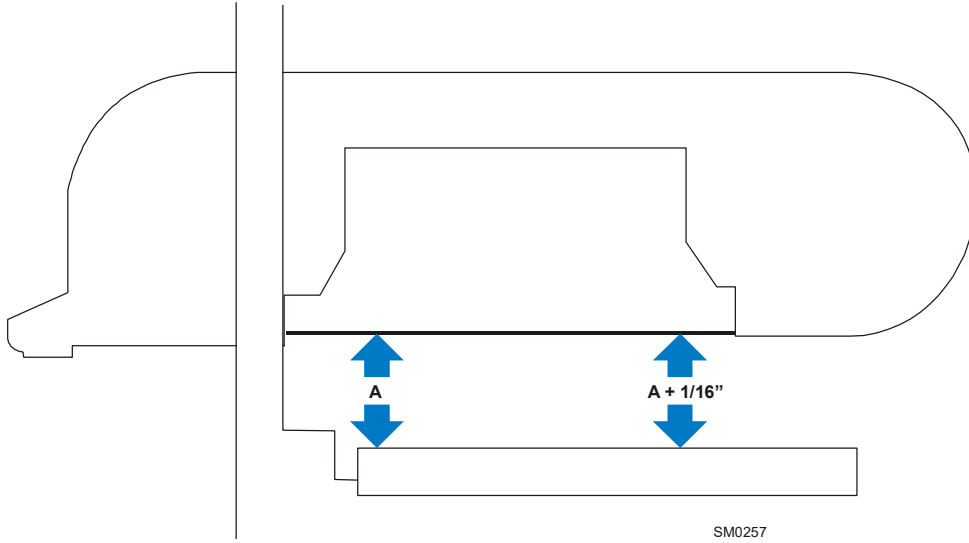

FIG. 7-1

3. Measure from the blade to the bed rail near the outer blade guide assembly. This measurement should be $1/16"$ (1.5 mm) higher than the inner measurement or $14 \frac{13}{16}"$ (376.5 mm).

To adjust the saw head tilt, use the horizontal adjustment nuts. To raise the outside of the saw head, loosen the four inner adjustment nuts 1/4 turn and tighten the four outer nuts. Recheck the measurement from the blade to the bed rails and adjust the horizontal adjustment nuts until the outside of the saw head is 1/16" higher than the inside.

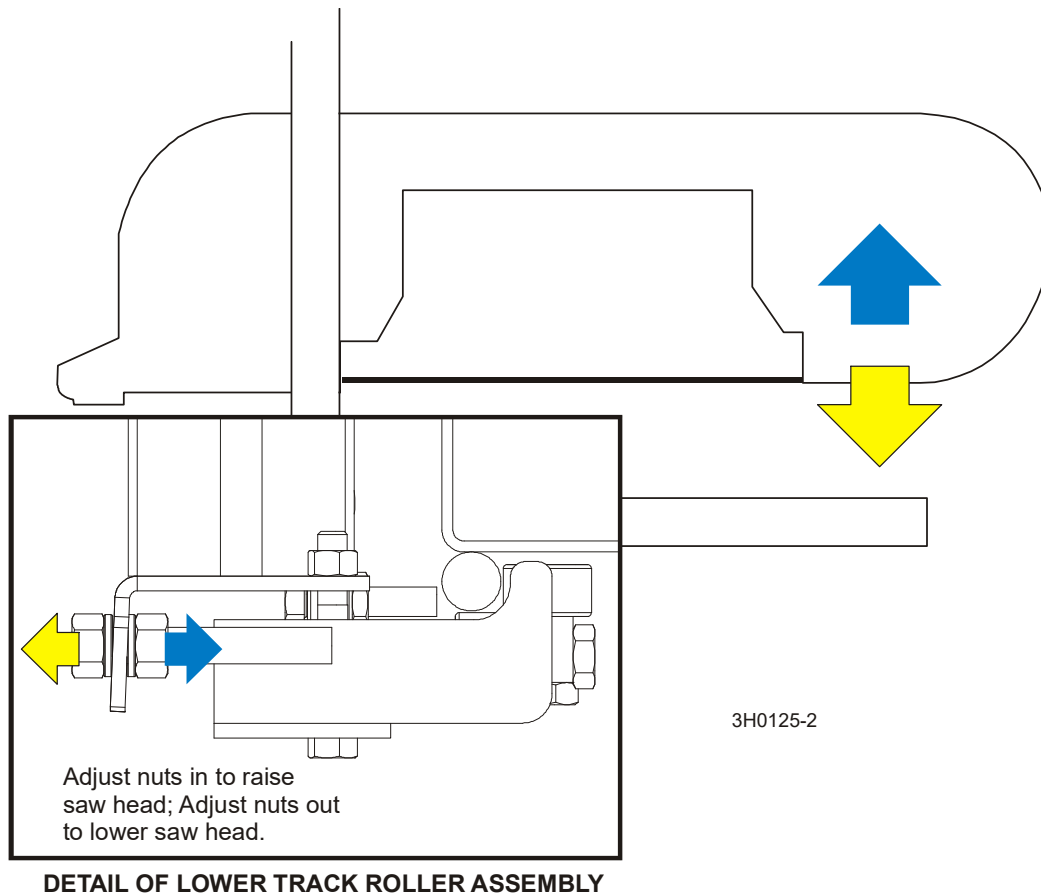

FIG. 7-2

BLADE GUIDE ARM ALIGNMENT

The blade guide arm moves the outer blade guide in and out. If the arm becomes loose, the blade guide will not deflect the blade properly, causing inaccurate cuts. A loose blade guide arm can also cause blade vibration.

1. Adjust the blade guide arm in to 1/2" (13 mm) from fully closed.
2. Manually try to move the arm up and down. If you can move the arm by hand, you will need to tighten the arm rollers.

Remove the blade housing cover to access the blade guide arm roller mounting bolts. The blade guide arm rollers are mounted on cam-shaped bolts. Turning the bolts will cause each roller to move up or

down. If the inner lower roller is loose, adjust the inner top roller down. If the outer lower roller is loose, adjust the outer lower roller up. Retighten the jam nuts and recheck the tightness of the bottom rollers .

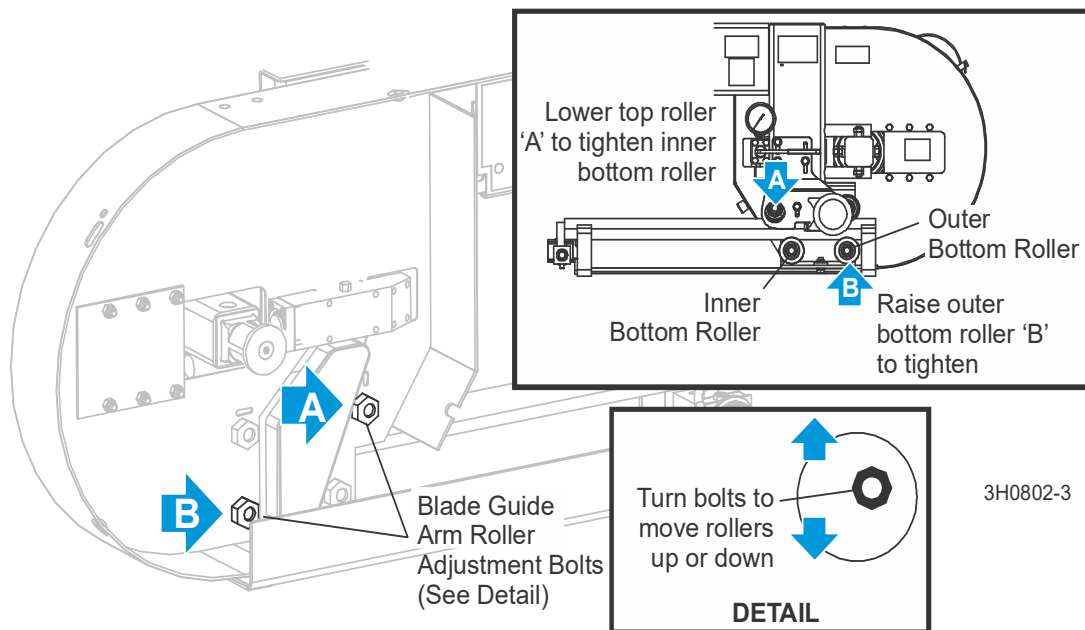

FIG. 7-3

After tightening the blade guide arm rollers, check that the arm is aligned properly.

3. With the arm adjusted 1/2" (12.7 mm) from fully closed, measure the distance between the blade guide roller flange and the back of the blade.

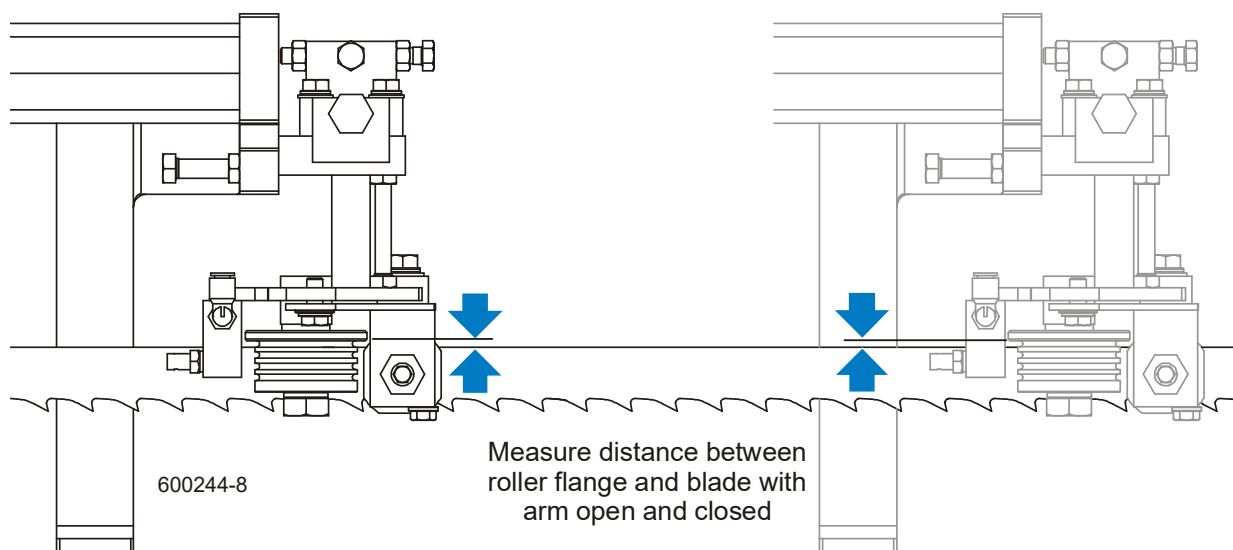

FIG. 7-4 (OPTIONAL HIGH-PERFORMANCE ROLLER/BLOCKS SHOWN)

4. Adjust the blade guide arm to 1/2" (12.7 mm) from fully open and remeasure the distance from the roller flange to the back of the blade. The two measurements should be the same. If not, adjust the outer rollers in or out to tilt the arm horizontally.

To tilt the arm in toward the blade, loosen the front nuts on the outer rollers and tighten the rear nuts. To tilt the arm out away from the blade, loosen the rear nuts on the outer rollers and tighten the front nuts. Recheck the blade guide arm horizontal tilt.

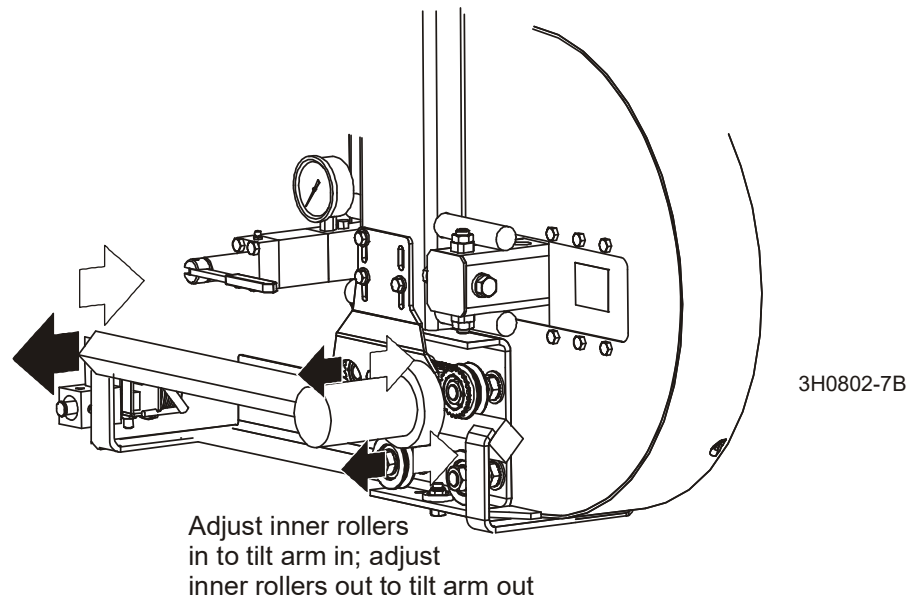
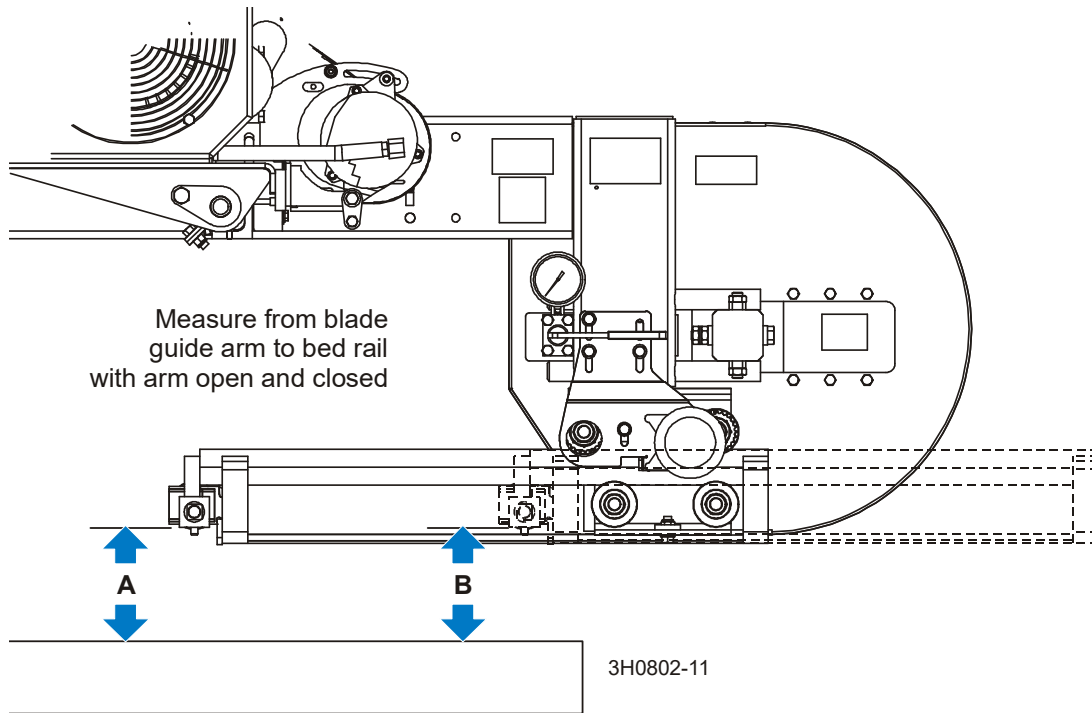

FIG. 7-5

5. Now check the vertical tilt of the blade guide arm. Move the saw carriage so the blade guide arm is positioned over a bed rail.
6. With the arm 1/2" (13 mm) from fully closed, raise or lower the saw head until the bottom of the blade guide block is 15" (375 mm) from the top of the bed rail.

**FIG. 7-6**

7. Adjust the blade guide arm to 1/2" (13 mm) from fully open. Measure the distance from the bottom of the blade guide mounting block to the bed rail. This measurement should be 15" (376.5 mm) or slightly higher because the saw head is tilted up 1/16" (1.5 mm) on the outside ([See Saw Head Tilt](#)). If the blade guide is closer to the bed rail or more than 1/16" (1.5mm) higher with the arm open, adjust the outer rollers up or down to tilt the blade guide arm vertically.

Remove the blade housing cover to access the blade guide arm roller mounting bolts. To adjust the rollers, loosen the jam nuts on the other side of the blade housing and turn the mounting bolts. To tilt the blade guide arm down, adjust the outer top and bottom rollers up. To tilt the blade guide arm up, adjust the outer top and bottom rollers down. Retighten the jam nuts and recheck the blade guide arm vertical tilt.

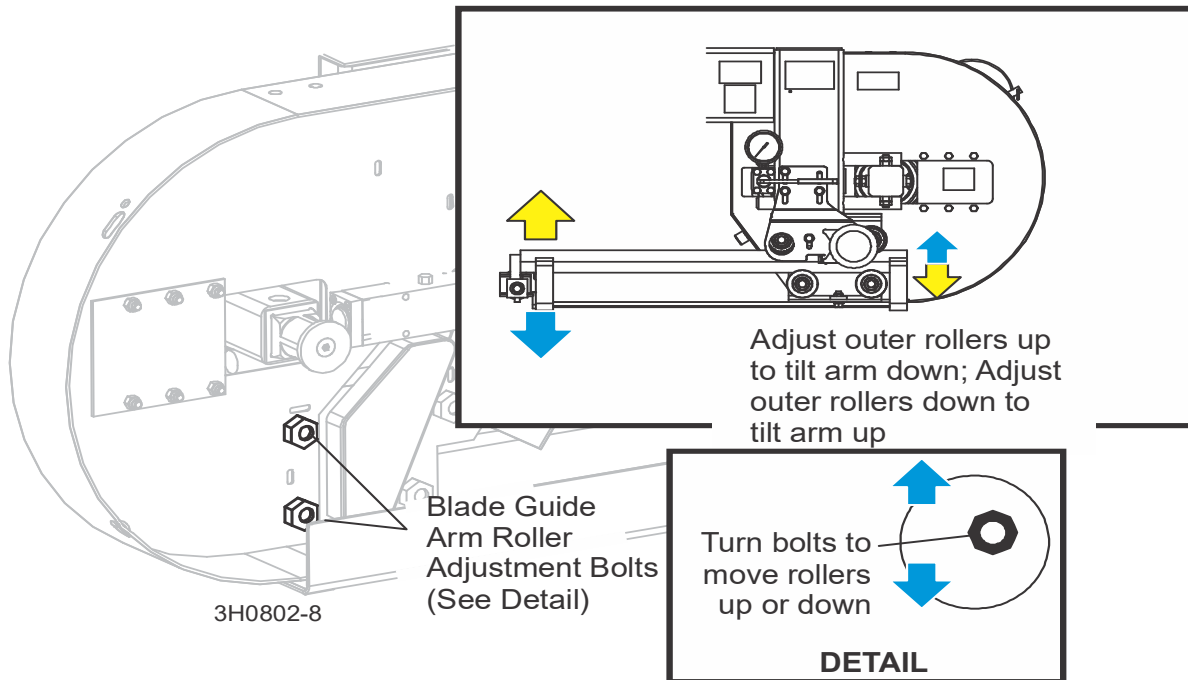

FIG. 7-7

BLADE GUIDE VERTICAL TILT ALIGNMENT

The blade guides should be adjusted properly in the vertical plane. If the blade guides are tilted vertically, the blade will try to travel in the tilted direction.

A Blade Guide Alignment Tool (BGAT) is provided to help you measure the vertical tilt of the blade.

1. Open the adjustable blade guide arm 1/2" (13 mm) from full open.
2. Clip the alignment tool on the blade. Position the tool close to the outer blade guide assembly. Be sure the tool does not rest on a tooth or burr, and is lying flat against the bottom of the blade.

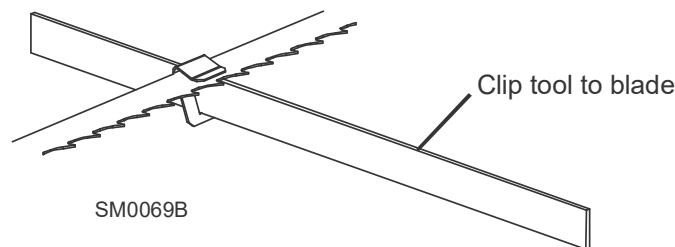

FIG. 7-8

3. Move the carriage so that the front end of the tool is positioned above the bed rail. Measure the distance from the bed rail to the bottom edge of the tool.
4. Move the carriage so that the back end of the tool is positioned above the bed rail. Measure the distance from the bed rail to the bottom edge of the tool.

5. If the measurement from the tool to the bed rail is not equal within 1/32" (.75 mm), adjust the vertical tilt of the outer blade guide roller.
6. Loosen one set screw at the side of the blade guide assembly.

Loosen the jam nuts on the top and bottom vertical tilt adjustment screws. To tilt the roller up, loosen the bottom screw and tighten top screw. To tilt the roller down, loosen the top screw and tighten the bottom screw. Tighten the jam nuts and recheck the tilt of the blade.

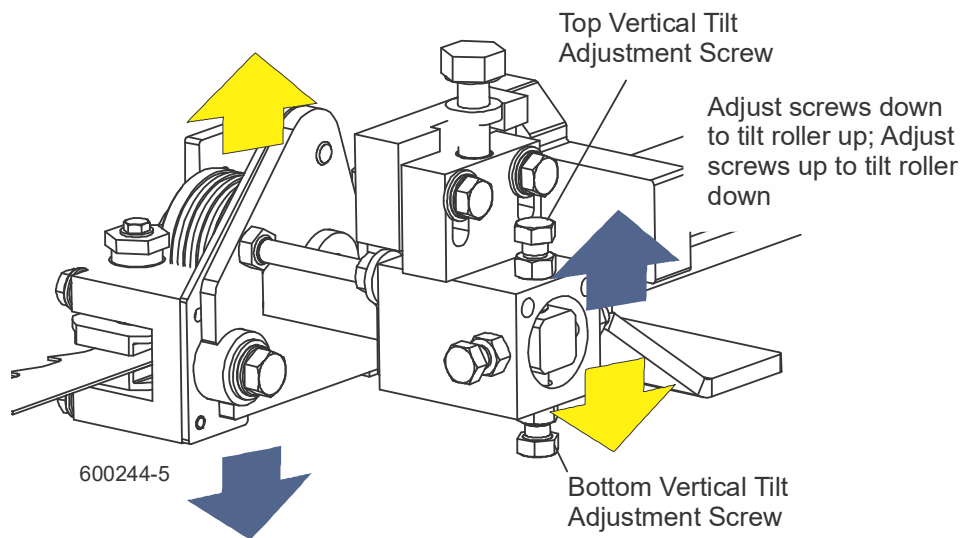

FIG. 7-9 (OPTIONAL HIGH-PERFORMANCE ROLLER/BLOCKS SHOWN)

7. Move the blade guide alignment tool close to the inner blade guide roller assembly and repeat the above steps. Adjust the vertical tilt of the inner blade guide if necessary.
8. After adjusting the vertical tilt of the blade guides, recheck the blade deflection and adjust if necessary.

BLADE GUIDE HORIZONTAL TILT ADJUSTMENT

If the blade guides are tilted in the wrong direction horizontally, the back of the blade may contact the flange as the roller is spinning down, causing it to push the blade away from the guide roller.

1. Remove the blade guide alignment tool from the blade and adjust the blade guide arm halfway in.
2. Remove the clip from the blade guide alignment tool. Place the tool against the face of the outer blade guide roller.

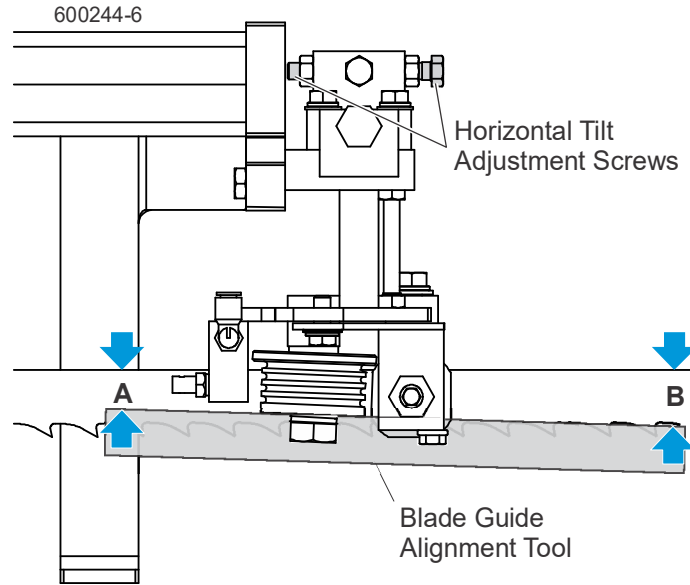

FIG. 7-10 (OPTIONAL HIGH-PERFORMANCE ROLLER/BLOCKS SHOWN)

3. Measure between the back edge of the blade and the tool at the end closest to the inner blade guide ("B").
4. Measure between the back edge of the blade and the other end of the tool ("A").

The roller should be tilted slightly to the left ('A' 1/8" [3 mm] less than 'B' ±1/8" [3 mm]).

5. Loosen the jam nuts on the horizontal tilt adjustment screws. To tilt the roller left, loosen the right screw and tighten left screw. To tilt the roller right, loosen the left screw and tighten the right screw. Tighten the jam nuts and recheck the tilt of the blade.

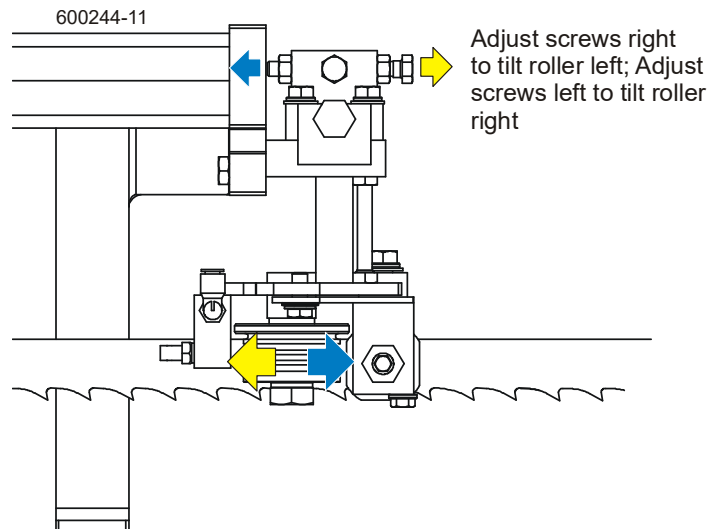

FIG. 7-11 (OPTIONAL HIGH-PERFORMANCE ROLLER/BLOCKS SHOWN)

6. Repeat the above steps for the inner blade guide roller assembly.

NOTE: Once the blade guides have been adjusted, any cutting variances are most likely caused by the blade. [See Blade Handbook, Form #600.](#)

BLADE GUIDE FLANGE SPACING

Each blade guide must be adjusted so the roller flange is the correct distance from the back edge of the blade. If the flange is too close to or too far from the blade, the sawmill will not cut accurately.

HINT: When adjusting blade guide spacing, loosen the top set screw and one side set screw only. This will ensure horizontal and vertical tilt adjustments are maintained when the adjustment screws are retightened.

1. Measure the distance between the flange on the outer blade guide roller to the back edge of the blade. This distance should measure 1/8" (3.0 mm). Adjust the roller back or forward if necessary.

Loosen the top and one side screw shown. Tap the blade guide forward or backward until properly positioned. Retighten the screws and jam nuts.

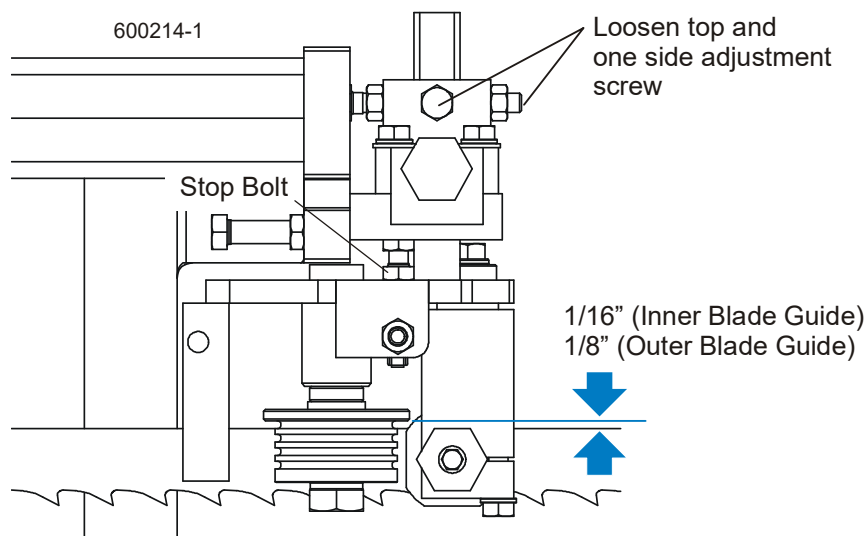

FIG. 7-12(OPTIONAL HIGH-PERFORMANCE ROLLER/BLOCKS SHOWN)

2. Measure the distance between the flange on the inner blade guide roller to the back edge of the blade. This distance should measure 1/16" (1.5 mm). Adjust the roller back or forward if necessary.

MANUAL SIDE SUPPORT ALIGNMENT

Logs and boards are clamped against the side supports when sawing. The sides supports must be square to the bed to ensure square lumber.

1. Swing a side support down and measure between the face of the support and the main bed tube. The distance at the top of the side support ('B') should be equal to or no more than 1/32" (0.8 mm) greater than the distance at the base of the side support ('A'). Adjust the horizontal tilt of the side support if necessary.

Loosen the two adjustment plate mounting bolts. Use a mallet to move the plate until the side support is parallel to the bed tube in the horizontal position. Retighten the mounting bolts.

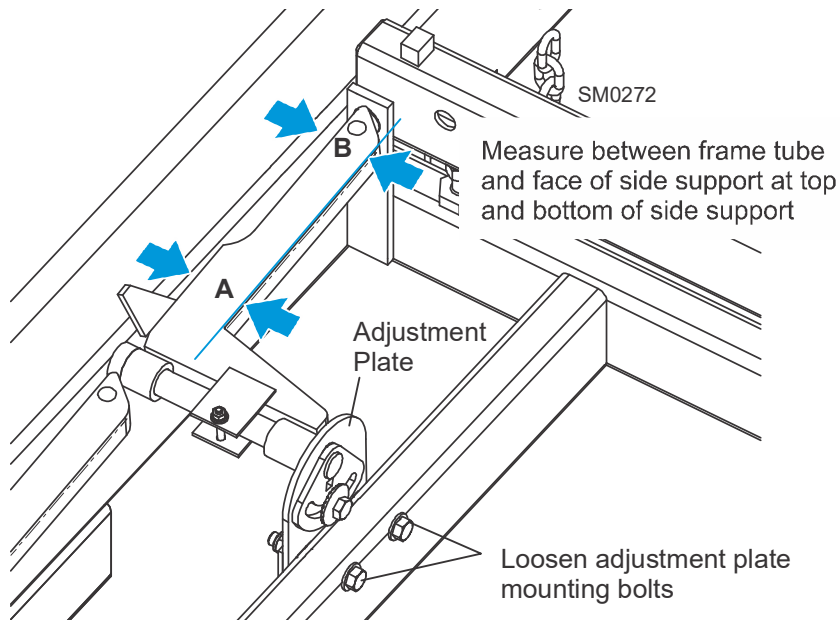

FIG. 7-13

2. Repeat the horizontal check for the remaining side supports. Adjust as necessary.
3. Place square alignment tubes (Part No. S12831 - 2 required) across the bed rails. Swing a side support up so that it is vertical.
4. Pull back at the top of the support to eliminate slack as if a log were being clamped against it.
5. Place a square against the face of the side support. The side support should be square or slightly tilted forward 1/32" (0.8 mm). Adjust the vertical tilt of the side support if necessary.

Loosen the side support mounting bolt. Use a 3/8" ratchet to rotate the pin until the side support is square to the bed.

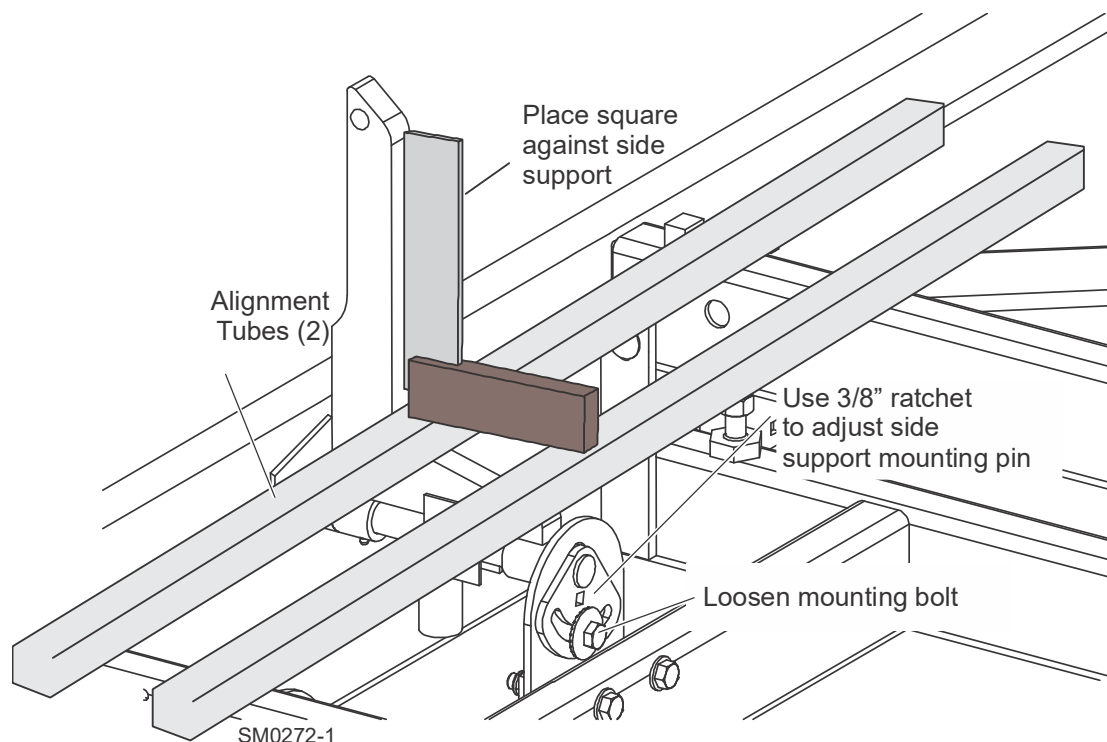

FIG. 7-14

6. Repeat the vertical check for the remaining side supports and adjust as necessary.

BLADE HEIGHT SCALE ADJUSTMENT

After the entire sawmill has been aligned and all adjustments made, check that the blade height scale indicates the true distance from the blade to the bed rails.

1. Move the saw carriage so the blade is positioned directly above one of the bed rails. Measure from the bottom edge on a down-set tooth of the blade to the top of the bed rail, near the inner blade guide assembly.
2. View the blade height scale with eyes level with the indicator. The scale should indicate the actual distance from the blade to the bed rail. Adjust the indicator if necessary.

Loosen the indicator bracket mounting bolts. Adjust the bracket up or down until the indicator is aligned with the correct mark on the scale (+0 -1/32 [0.8 mm]). Retighten the bracket mounting bolts.

For example, if the measurement from the down-set tooth of the blade to the bed rail was 14 3/4" (375 mm), make sure the indicator reads 14 3/4" (375 mm) on the scale.

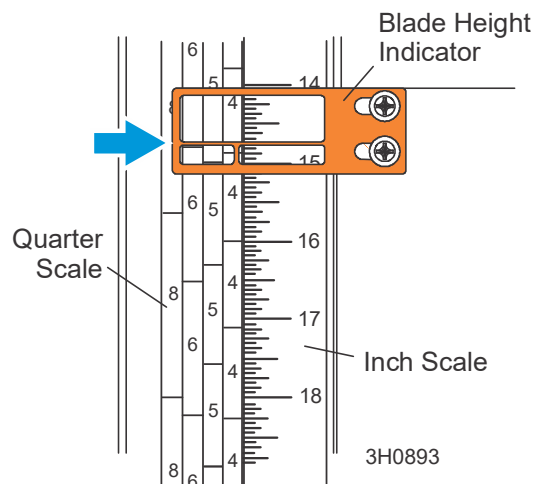

FIG. 7-15

7.2 Complete Alignment Procedure

NOTE: THE PROCEDURES LISTED HERE MUST BE PERFORMED IN THE ORDER THEY APPEAR.

Frame Setup

Before performing the following alignment procedures, setup the mill on firm, level ground.

If your sawmill is stationary, with no trailer axle, shim the feet so the weight of the sawmill is evenly supported.

If your sawmill has a trailer axle and adjustable outriggers, adjust the outriggers as follows:

LT30: Adjust the two outriggers on the main frame tube down just enough to lift weight from the trailer tire.

LT40: Adjust the front and third outriggers on the main frame tube down just enough to lift weight from the trailer tire.

All Portable Sawmills: Adjust the two outer outriggers down just so they touch the ground but do not bear weight.

See [SECTION 3](#) for additional setup information.

Blade Installation

1. Remove the blade and replace the blade wheel belts. New blade wheel belts are required to perform the complete alignment procedure.
2. Blow sawdust off of the blade guide assemblies. Remove sawdust from the blade housings.
3. Remove the blade guide assemblies.

NOTE: To remove the blade guide assemblies and maintain the tilt adjustments, only loosen one side screw and the top screw. Leaving the other side screw and bottom screw in position will insure you will return the rollers to their original tilt adjustment.

4. Adjust the outer blade guide arm in or out until the outer blade guide is approximately 24" from the inner blade guide.
5. Install a new blade and apply the appropriate tension ([See Section 3.4](#)).
6. Close the middle blade housing cover and make sure all persons are clear of the open side of the saw head.
7. Start the engine (or motor).
8. Engage the blade, rotating the blade until the blade positions itself on the wheels.



WARNING! Do not spin the blade wheels by hand. Spinning the blade wheels by hand may result in serious injury.

9. Disengage the blade. Turn the engine off and remove the key.

Saw Head Slide Pad Adjustment

There are eight nylon pads positioned between the saw head frame and vertical mast. The spacing of the pads is factory set and rarely needs adjusting. To check the pad spacing, perform the following steps.

NOTE: The pads on the engine side of the mast are referred to as the "inner" pads. The pads on the control side of the mast are referred to as the "outer" pads.

NOTE: Shims are often used around the clamping bolts, between the C-frame support bracket and the mast v-brace. The shims align the v-brace to the mast so that the entire face of each slide pad makes contact with the mast. Be sure to keep these shims in place when performing the following adjustment.

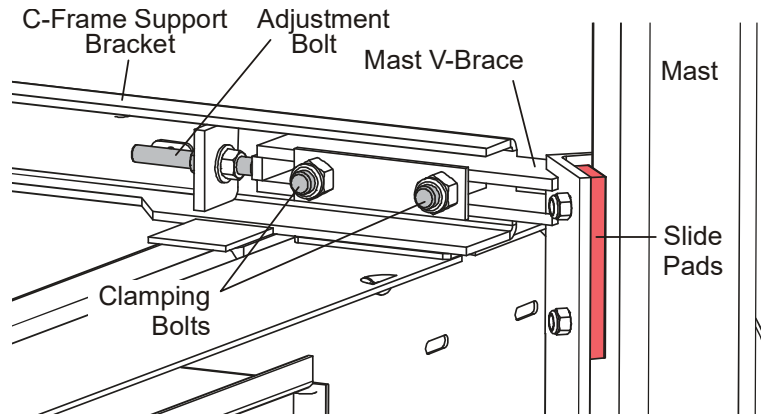

FIG. 7-16

1. Raise the saw head to the top of the vertical mast and secure the saw head with a chain at the top. Check the top set of four pads. The outer two pads should be touching the mast rails. There should be a small gap (just wide enough to slide a business card through) between one of the inner pads and the mast rail.



WARNING! Always secure the saw head with a 5/16" (8mm) chain with at least 1900 lbs. (860Kg) working load capacity before adjusting the mast pads. The cutting head may fall, causing severe injury or death.

2. Make sure the saw head is adjusted up off the safety chain to ensure the chain is not affecting the alignment of the mast pads.
3. To adjust the spacing of the upper set of pads, lower the saw head until you can access the upper slide pad adjustment bolts.
4. Loosen the upper locking bolts and turn the adjusting bolt as necessary to provide the pad spacing described in Step 1.
5. Lower the saw head to the bottom of the vertical mast. Check the bottom set of four pads.

There should be a small gap between one of the outer pads and the mast rail. The gap should be just wide enough to slide a business card through. The inner two pads should be touching the mast rails. To adjust the spacing of the lower set of pads, raise the saw head until you can access the lower slide pad adjustment bolts.

6. Loosen the lower locking bolts and turn the adjusting bolt as necessary to provide the pad spacing described in Step 5.



CAUTION! Due to variations in the vertical mast, the pad spacing may vary throughout the travel of the saw head. Check the pad spacing at the top and bottom ends of the mast only. Pads adjusted too tight will cause premature up/down motor failure.

Blade Wheel Alignment

The blade wheels should be adjusted so they are level in the vertical and horizontal planes. If the blade wheels are tilted up or down, the blade will want to travel in the tilted direction. If the blade wheels are tilted horizontally, the blade will not track properly on the wheels.

1. Use the blade guide alignment tool to check the vertical alignment of each blade wheel. Attach the tool to the blade near the inner blade guide mount. Be sure the tool does not rest on a tooth or burr, and is lying flat against the bottom of the blade.

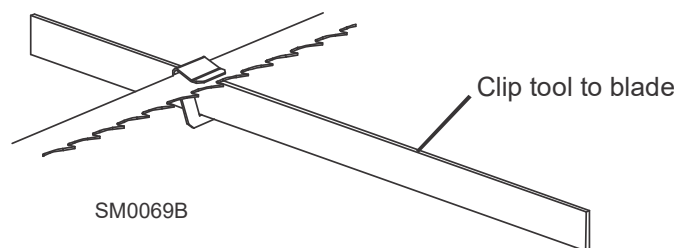

FIG. 7-17

2. Move the saw carriage so the front end of the tool is positioned over the first bed rail. Measure from the bottom of the tool to the top surface of the bed rail.
3. Move the saw carriage so the rear of the tool is positioned over the bed rail. Again, measure from the bottom of the tool to the bed rail.
4. If the two measurements differ by more than 1/16" (1.5 mm), adjust the vertical tilt of the drive-side blade wheel.

Use the vertical adjustment screws to adjust the drive-side blade wheel. To tilt the wheel up, loosen the top adjustment screw one quarter turn. Loosen the jam nut on the bottom adjustment screw and tighten the screw to 30 ft.-lbs torque. Tighten the top and bottom jam nuts. To tilt the wheel down, loosen the bottom adjustment screw one quarter turn. Loosen the jam nut on the top adjustment screw and tighten the screw to 30 ft.-lbs torque. Tighten the top and bottom jam nuts.

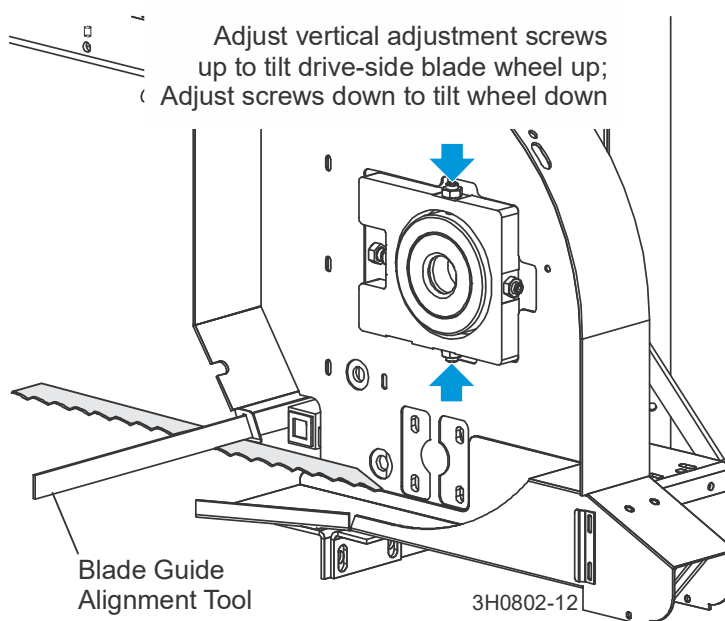

FIG. 7-18

5. Recheck the vertical tilt of the drive-side blade wheel with the blade guide alignment tool. Readjust the blade wheel as necessary until the front and rear of the tool are the same distance from the bed rail (within 1/16" [1.5 mm]).
6. Remove the tool from the blade and reattach it near the outer blade guide assembly.
7. Measure from the tool to the bed rail at both ends of the tool. If the measurements at the front and rear ends of the tool differ by more than 1/16" (1.5 mm), adjust the vertical tilt of the idle-side blade wheel.

Use the vertical adjustment screws to adjust the idle-side blade wheel. To tilt the wheel up, loosen the bottom adjustment screw one quarter turn. Loosen the jam nut on the top adjustment screw and tighten the screw. Tighten the top and bottom jam nuts. To tilt the wheel down, loosen the top adjustment screw one quarter turn. Loosen the jam nut on the bottom adjustment screw and tighten the screw. Tighten the top and bottom jam nuts.

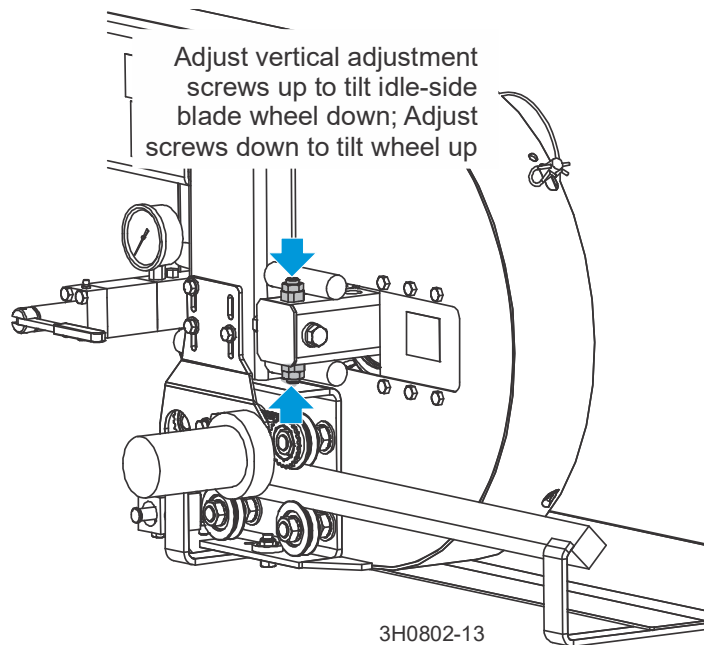

FIG. 7-19

8. Recheck the vertical tilt of the idle-side blade wheel with the blade guide alignment tool. Readjust the blade wheel as necessary until the front and rear of the tool are the same distance from the bed rail (within $1/16"$ [1.5 mm]).
9. Check the position of the blade on the idle-side blade wheel.

The horizontal tilt of the blade wheel should be adjusted so that the gullet of an 1-1/4" blade is 1/8" (3 mm) out from the front edge of the wheel ($\pm 1/16"$ [1.5 mm]). The gullet of an 1-1/2" blade should be

3/16" (4.5 mm) out from the front edge of the wheel ($\pm 1/16$ [1.5 mm]). Do not let the teeth ride on the wheels.

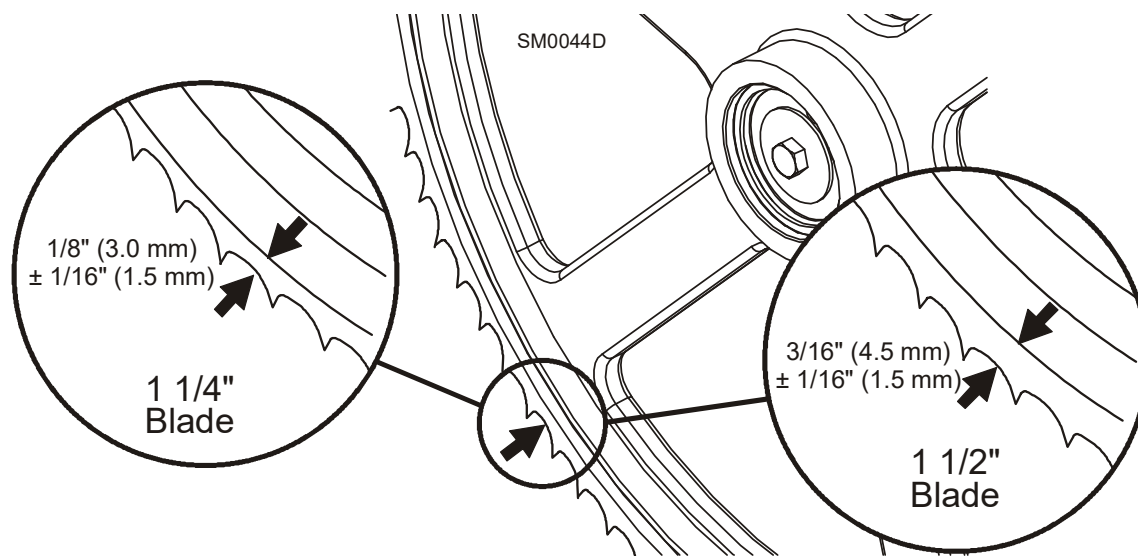

FIG. 7-20

Use the cant control adjustment to adjust the idle-side blade wheel. If the blade is too far forward on the wheel, turn the cant control counterclockwise. If it is too far back on the wheel, turn the cant control clockwise.

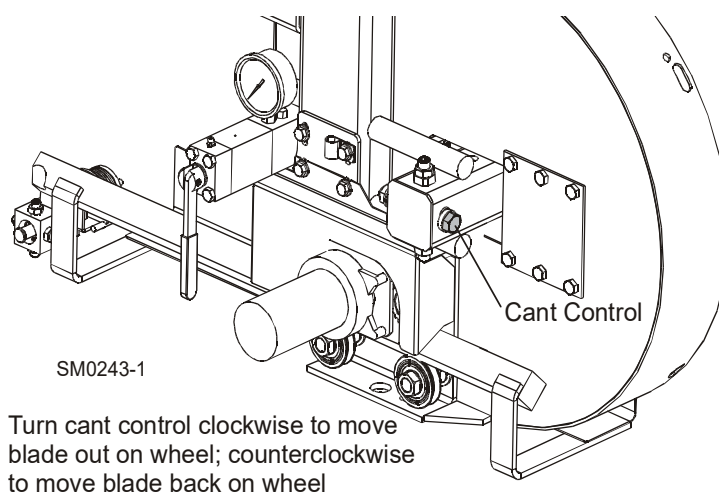

FIG. 7-21

10. Check the position of the blade on the drive-side blade wheel. The blade should be positioned on the wheel as described for the idle-side blade wheel. Adjust the drive-side blade wheel if necessary.

Use the horizontal adjustment screws to adjust the drive-side blade wheel. To move the blade back on the wheel, loosen the right adjustment screw one quarter turn. Loosen the jam nut on the left adjustment screw and tighten the screw to 30 ft.-lbs torque. Tighten the left and right jam nuts.

To move the blade out on the wheel, loosen the left adjustment screw one quarter turn. Loosen the jam

nut on the right adjustment screw and tighten the screw to 30 ft.-lbs torque. Tighten the left and right jam nuts.

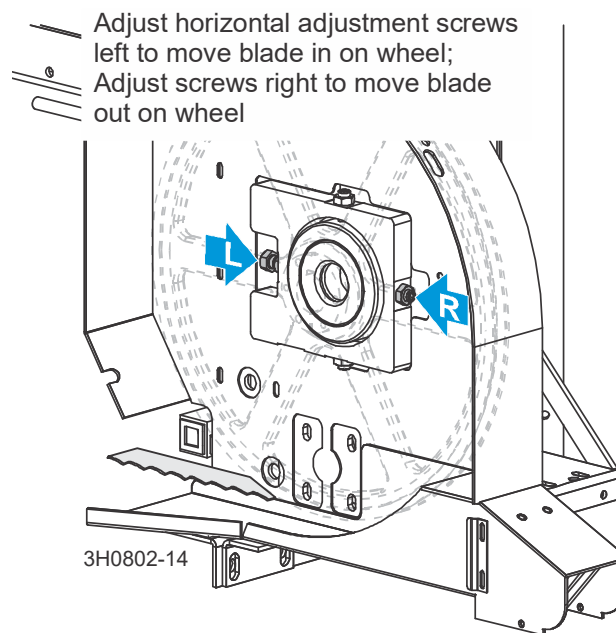

FIG. 7-22

Track Roller Adjustment

Making these adjustments correctly will insure the saw carriage travels smoothly along the track and blade will remain parallel with the bed frame.

1. Using the feed controls, move the saw carriage so that the blade is positioned over the front pivot end rail.
2. Check the lower stop blocks on the bottom track rail. Make sure that the stop blocks are adjusted 1/32"-1/16" (.75mm - 1.5mm) from the track rail. Use the vertical bolts to adjust the stop blocks.

Tighten the vertical adjustment bolt to move the stop block toward the track rail. Loosen the bolt to move the stop block away from the track rail.

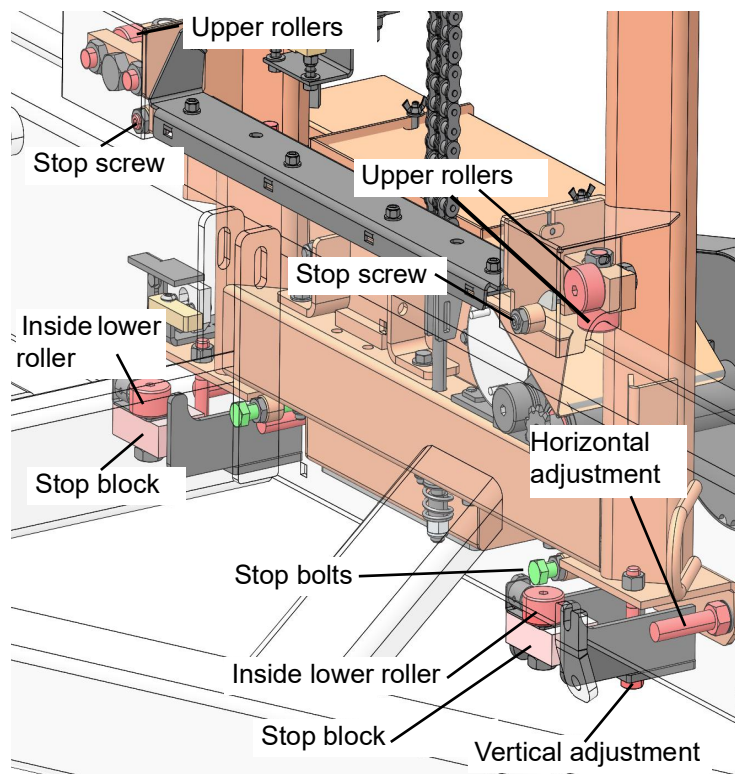

FIG. 7-23

3. Check the inside lower rollers. Both inside rollers should touch the rail so that you cannot spin them by hand. If the rollers are not adjusted evenly and you can spin one, adjust the horizontal adjustment nuts until the roller cannot be spun by hand. Stop adjusting before the other roller can be spun by hand. The two inside rollers should bear the weight of the saw carriage evenly.
4. Move the carriage forward until the blade is positioned over the rear pivot end rail. Repeat steps 2 & 3 until all lower rollers are adjusted properly at the front and rear of the sawmill.
5. Open the adjustable blade guide arm to within 1/2" (15 mm) of full open.
6. Move the carriage back to the front pivot end rail. Raise the saw head until the bottom of the blade is 17" (400 mm) above the outside of the pivot rail support by actual measurement with a tape or ruler.

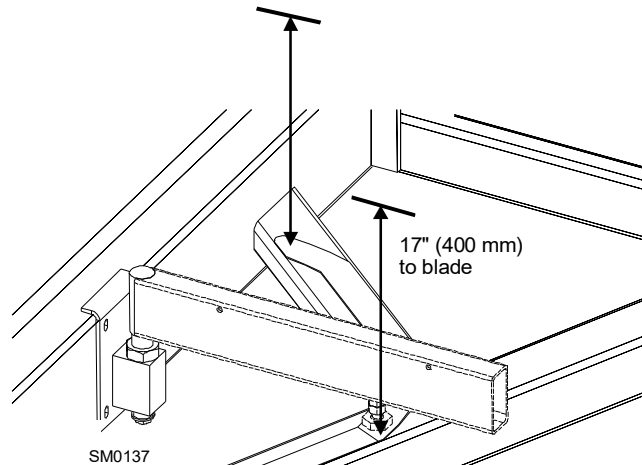

FIG. 7-24

7. Move the carriage forward to check the distance to the blade at the inside of the pivot rail support. All measurements should be equal within $1/32$ " (0.8 mm).

To adjust the saw head tilt, use the horizontal adjustment nuts. To raise the outside of the saw head, loosen the four inner adjustment nuts $1/2$ turn then tighten the four outer nuts. To lower the outside of the saw head, loosen the four outer adjustment nuts $1/2$ turn then tighten the inner nuts. Recheck the saw head tilt and readjust the nuts as necessary.

8. After the lower track rollers are adjusted properly, adjust the upper and lower stop screws. Tighten each screw until it just touches the rail. Then, back the screw off $1/2$ turn. The gap will be approximately $1/32$ " (0.8mm).

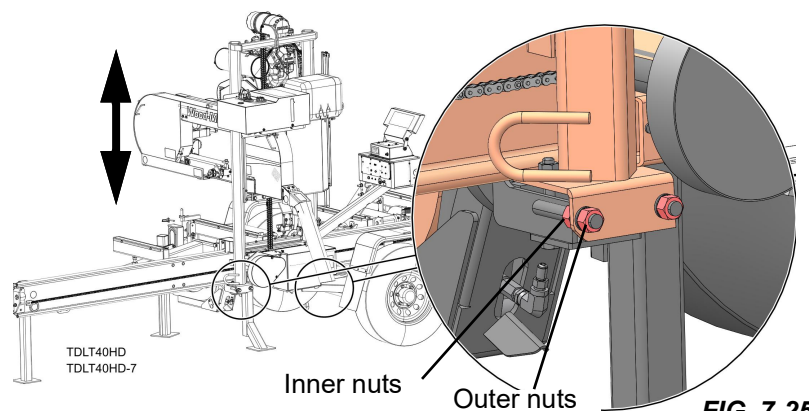

FIG. 7-25



CAUTION! It is important that the lower stop bolts are properly adjusted to secure the carriage on the track rail. Failure to properly adjust the stop bolts can cause saw head damage, especially during mill transportation.

Bed Rail Adjustment

1. Install the log clamp at its lowest setting in a hole where the clamp is positioned 10" (254mm) from the clamp stop (fourth hole from stop). Move the saw head until the blade is centered over the clamp. Raise the saw head until the

blade measures 14 1/2" (360 mm) from the top of the clamp. Use a rule to determine the actual distance of the blade to the clamp.

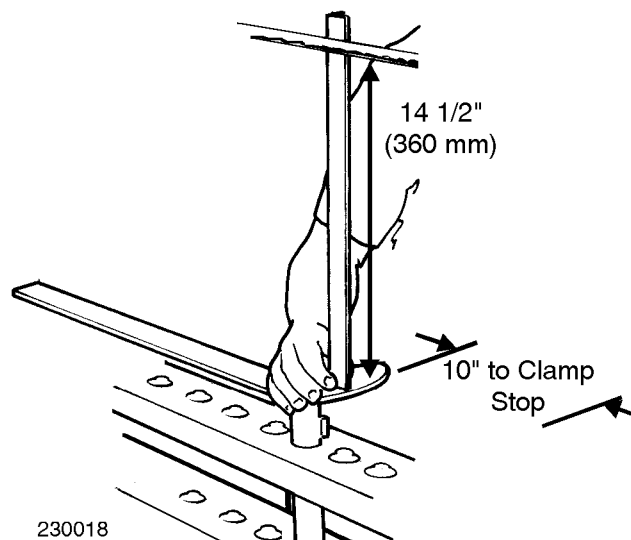

FIG. 7-26

2. Adjust the front pivot rail 90° to the main bed tube.
3. Move the saw head to center the blade over the front pivot bed rail.
4. Measure the distance from the top of the pivot rail to the bottom of the blade. Make this measurement at each end of the pivot rail.
5. The two measurements should be 15" (375 mm).

Loosen the locking set screws and turn the inner height adjustment nut to adjust the height of the inner end of the pivot rail. Loosen the jam nut and turn the outer adjustment bolt to adjust the height of the outer end of the pivot rail.

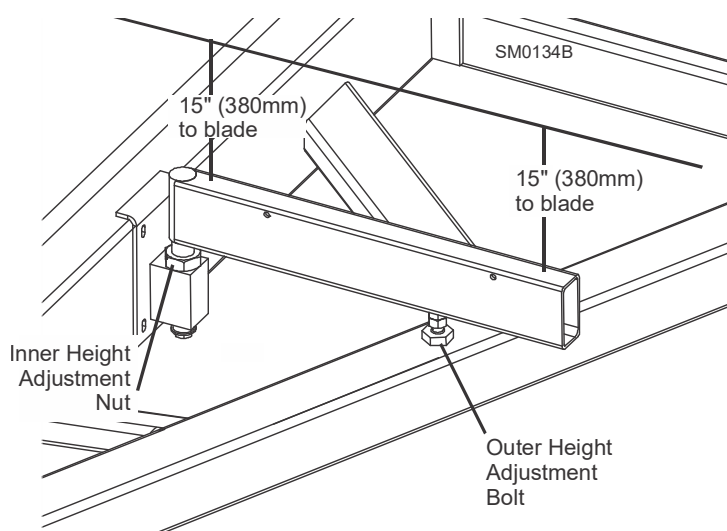

FIG. 7-27

6. Move the saw head so the blade is positioned over the center of the front main bed rail.
7. Measure the distance between the bottom of the blade and the bed rail at each end of the bed rail. The bed rail should measure 15" (375 mm) from the blade at each end of the rail.

Loosen the bed rail clamping bolts and turn the adjustment bolts to move the bed rails to the blade if necessary. Retighten the clamping bolts and adjustment bolt jam nuts.

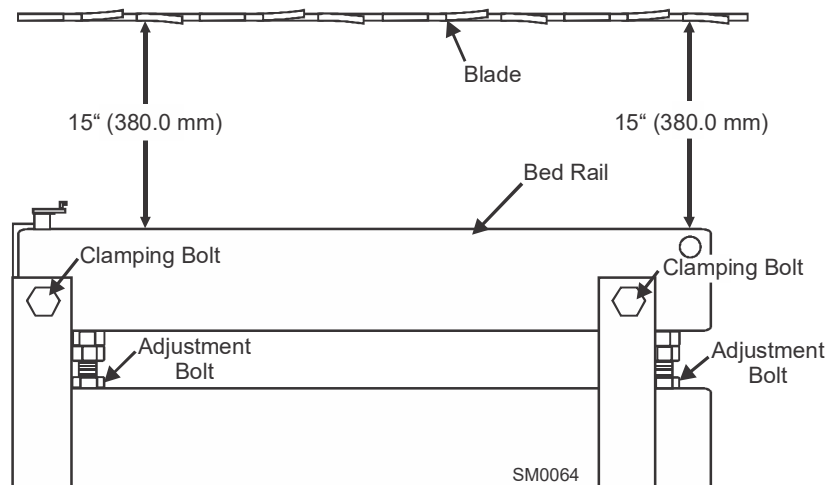

FIG. 7-28

- Without adjusting the saw head height, check the three remaining main bed rails and the rear pivot rail. Adjust them so that all measure the same distance from the blade at both ends of the bed rail.

Blade Guide Installation

Each Wood-Mizer sawmill has two blade guide assemblies that help the blade maintain a straight cut. The two blade guide assemblies are positioned on the saw head to guide the blade on each side of the material being cut.

One blade guide assembly is mounted in a stationary position on the drive side of the saw head. This assembly is referred to as the "inner" blade guide assembly.

The other blade guide assembly is mounted on the idle side of the saw head. It is referred to as the "outer" assembly and is adjustable for various widths of materials to be processed.

NOTE: Before installing the blade guide assemblies, remove the blade guide adjusting screws and apply a lubricating oil such as 10W30 or Dexron III to each screw. This will prevent the screws and threaded holes from corroding and make screw adjustments easier.

NOTE: If blade guides equipped with optional high-performance blocks, remove the blade from the sawmill before installing the blade guide assemblies. Place both guide assemblies in the mounts then reinstall, tension and track the blade properly.

BLADE GUIDES EQUIPPED WITH HIGH-PERFORMANCE BLOCKS:

Inspect the guide blocks and repair or replace as necessary. Remove the blade from the sawmill.

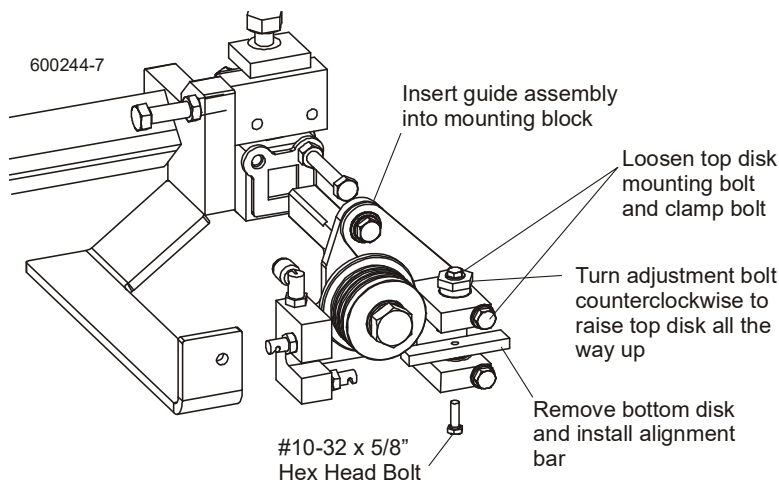

FIG. 7-29 (OPTIONAL HIGH-PERFORMANCE ROLLER/BLOCKS SHOWN)

9. Loosen the top block clamp bolt and mounting bolt. Turn the adjustment bolt counterclockwise to raise the top block all the way up. Remove the bottom guide block from each blade guide assembly and install the provided alignment bar.
10. Install each blade guide assembly to the mounting blocks and push all the way back. Install, tension and track a new blade. Adjust the outer blade guide assembly so the roller flange is 1/8" from the back of the blade. Adjust the inner blade guide assembly so the roller flange is 1/16" from the blade.

BLADE GUIDES NOT EQUIPPED WITH HIGH-PERFORMANCE BLOCKS:

1. Install the outer blade guide assembly (with waterlube tube) to the mounting block on the blade guide arm. Position the assembly so the roller flange is 1/8" (3.0 mm) from the blade.
2. Install the inner blade guide assembly to the mounting block on the saw head. Position the assembly so the roller flange is 1/16" (1.5 mm) from the blade.

Tighten the two previously-loosened tilt adjustment screws to secure the blade guide assembly.

Turn the top adjustment bolt clockwise to raise the blade guide assembly so the roller does not contact the blade.

NOTE: Before adjusting the top bolt, unload pressure on the bolt by turning 1/2 turn in the opposite direction it was last adjusted.

With the roller flange positioned properly from the back of the blade, adjust the stop bolt so it touches the blade guide bracket.

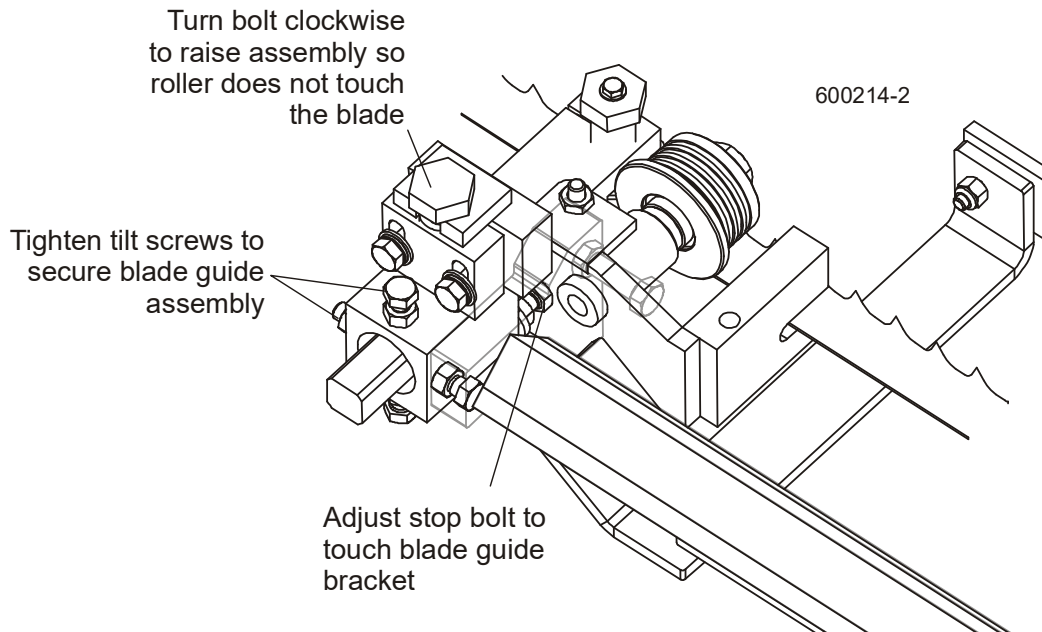

FIG. 7-30

Blade Guide Arm Alignment

The blade guide arm moves the outer blade guide in and out. If the arm becomes loose, the blade guide will not deflect the blade properly, causing inaccurate cuts. A loose blade guide arm can also cause blade vibration.

1. Adjust the blade guide arm in to 1/2" (13 mm) from fully closed.
2. Manually try to move the arm up and down. If you can move the arm by hand, you will need to tighten the arm rollers.

Remove the blade housing cover to access the blade guide arm roller mounting bolts. The blade guide arm rollers are mounted on cam-shaped bolts. Turning the bolts will cause each roller to move up or

down. If the inner lower roller is loose, adjust the inner top roller down. If the outer lower roller is loose, adjust the outer lower roller up. Retighten the jam nuts and recheck the tightness of the bottom rollers.

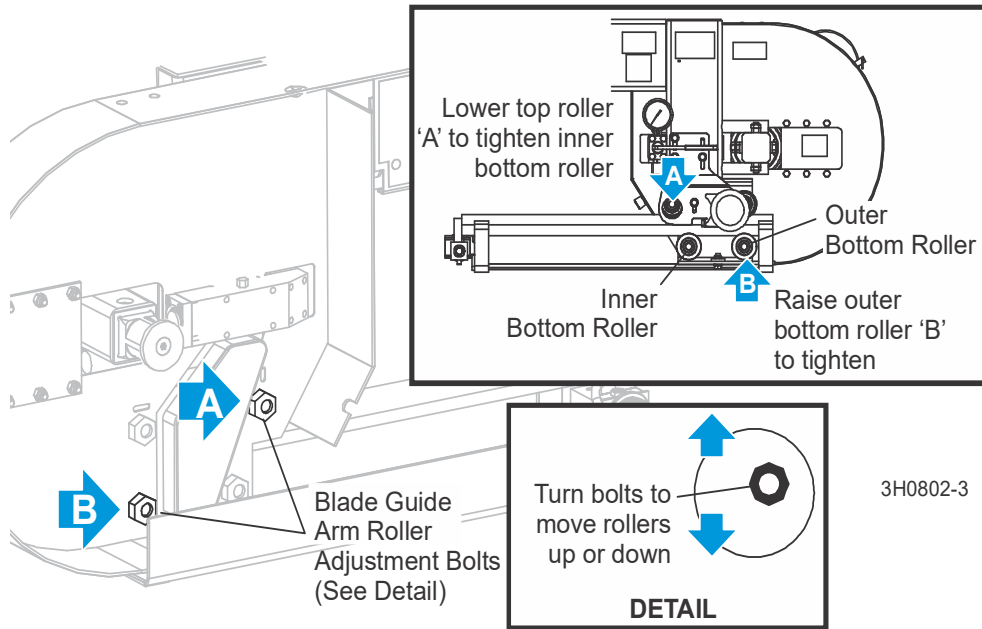

FIG. 7-31

After tightening the blade guide arm rollers, check that the arm is aligned properly.

3. With the arm adjusted 1/2" (13 mm) from fully closed, measure the distance between the blade guide roller flange and the back of the blade.

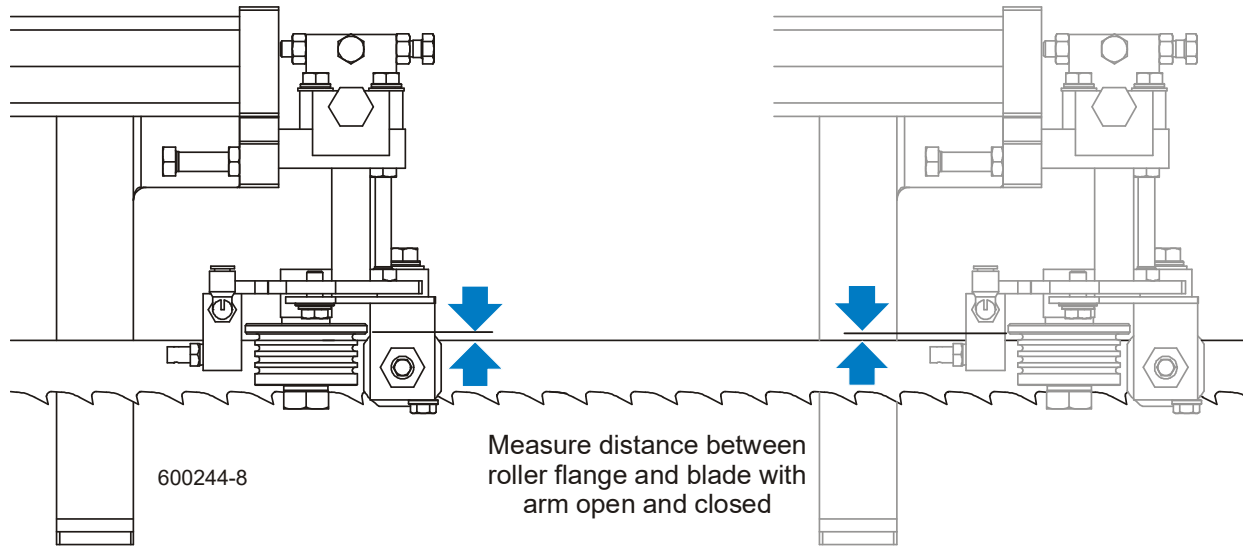

FIG. 7-32 (OPTIONAL HIGH-PERFORMANCE ROLLER/BLOCKS SHOWN)

4. Adjust the blade guide arm to 1/2" (13 mm) from fully open and remeasure the distance from the roller flange to the back of the blade. The two measurements should be the same. If not, adjust the inner rollers in or out to tilt the arm horizontally.

To tilt the arm out away from the blade, loosen the front nuts on the inner rollers and tighten the rear nuts. To tilt the arm in toward the blade, loosen the rear nuts on the inner rollers and tighten the front nuts. Recheck the blade guide arm horizontal tilt.

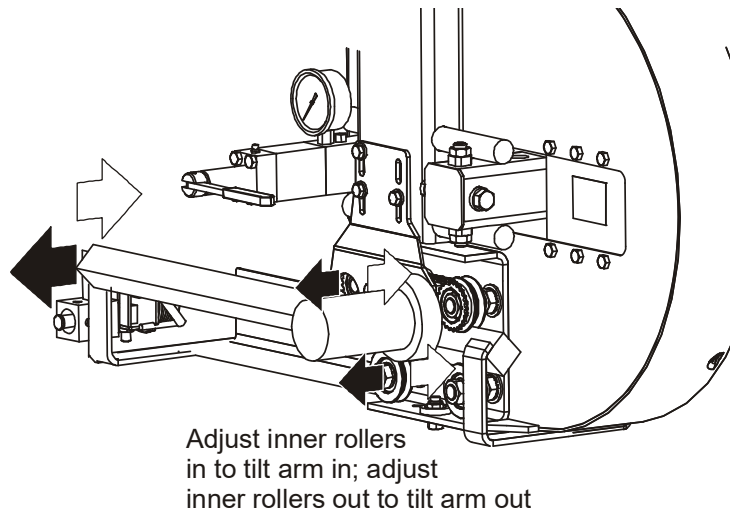

FIG. 7-33

5. Now check the vertical tilt of the blade guide arm. Move the saw carriage so the blade guide arm is positioned over a bed rail.
6. With the arm 1/2" (15 mm) from fully closed, raise or lower the saw head until the bottom of the blade guide block is 15" (375 mm) from the top of the bed rail.

Adjust the blade guide arm to 1/2" (15 mm) from fully open. Measure the distance from the bottom of the blade guide mounting block to the bed rail. This measurement should be 15" (376.5 mm). If the measurements are not the same, adjust the outer rollers up or down to tilt the blade guide arm vertically.

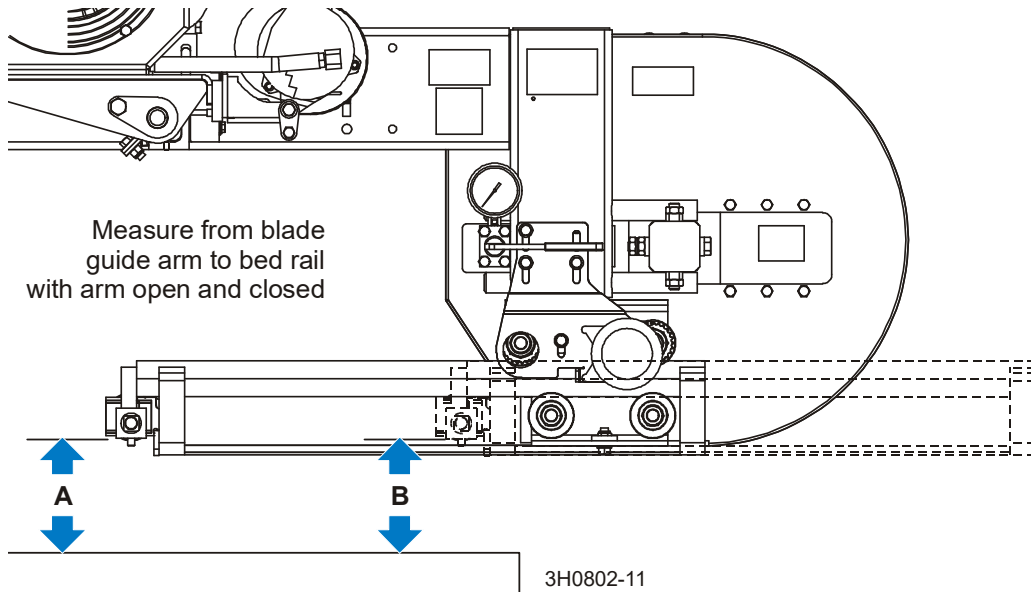

FIG. 7-34

Remove the blade housing cover to access the blade guide arm roller mounting bolts. To adjust the rollers, loosen the jam nuts on the other side of the blade housing and turn the mounting bolts. To tilt the blade guide arm down, adjust the outer top and bottom rollers up. To tilt the blade guide arm up, adjust the outer top and bottom rollers down. Retighten the jam nuts and recheck the blade guide arm vertical tilt.

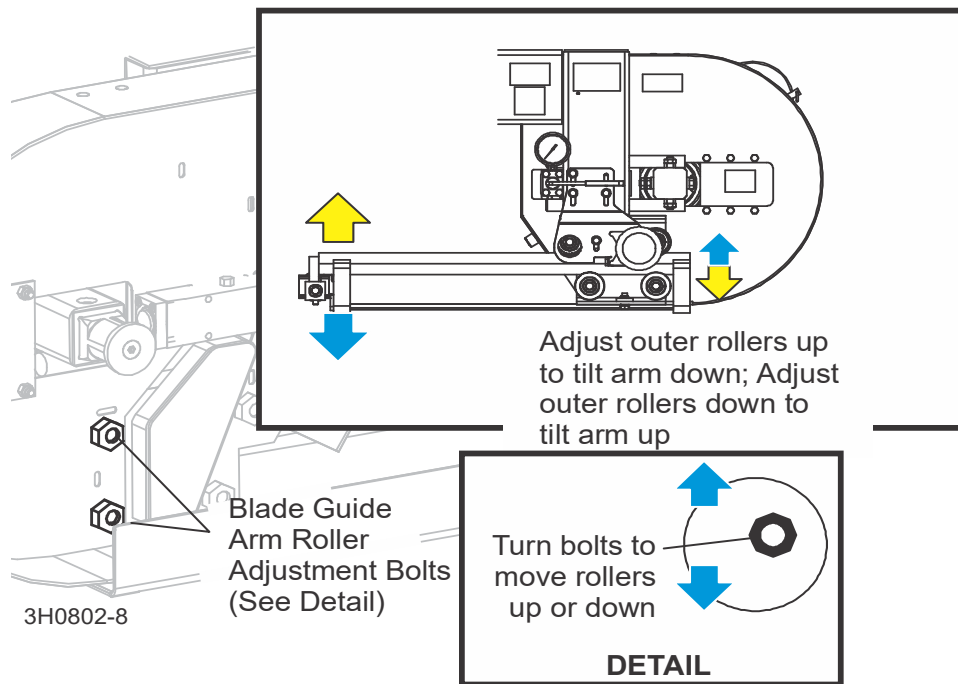

FIG. 7-35

Blade Guide Deflection

1. Raise the saw head until the blade is 15" (375 mm) above a bed rail. Measure the actual distance with a tape from the top of the rail to the bottom of the blade.

Turn the top adjustment bolt counterclockwise to lower the assembly until the blade guide roller deflects the blade down until the bottom of the blade measures 14 3/4" (370 mm) from the bed rail.

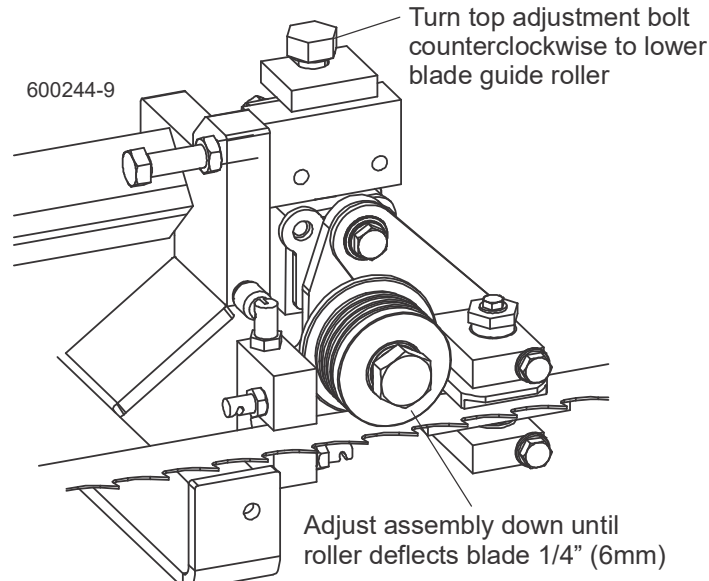

FIG. 7-36

NOTE: Before adjusting the top bolt, unload pressure on the bolt by turning 1/2 turn in the opposite direction it was last adjusted.

2. Repeat for the other blade guide.

Blade Guide Vertical Tilt Alignment

The blade guides should be adjusted properly in the vertical plane. If the blade guides are tilted vertically, the blade will try to travel in the tilted direction.

A Blade Guide Alignment Tool (BGAT) is provided to help you measure the vertical tilt of the blade.

1. Open the adjustable blade guide arm 1/2" (13 mm) from full open.
2. Clamp the alignment tool on the blade. Position the tool close to the outer blade guide roller. Be sure the tool does not rest on a tooth or burr, and is lying flat on the blade.

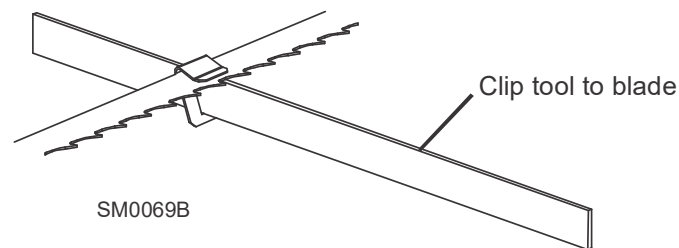

FIG. 7-37

3. Move the carriage so that the front end of the tool is positioned above the bed rail. Measure the distance from the bed rail to the bottom edge of the tool.

4. Move the carriage so that the back end of the tool is positioned above the bed rail. Measure the distance from the bed rail to the bottom edge of the tool.
5. If the measurement from the tool to the bed rail is not equal within 1/32" (.75 mm), adjust the vertical tilt of the outer blade guide roller.
6. Loosen one set screw at the side of the blade guide assembly.

Loosen the jam nuts on the top and bottom vertical tilt adjustment screws. To tilt the roller up, loosen the bottom screw and tighten top screw. To tilt the roller down, loosen the top screw and tighten the bottom screw. Tighten the jam nuts and recheck the tilt of the blade.

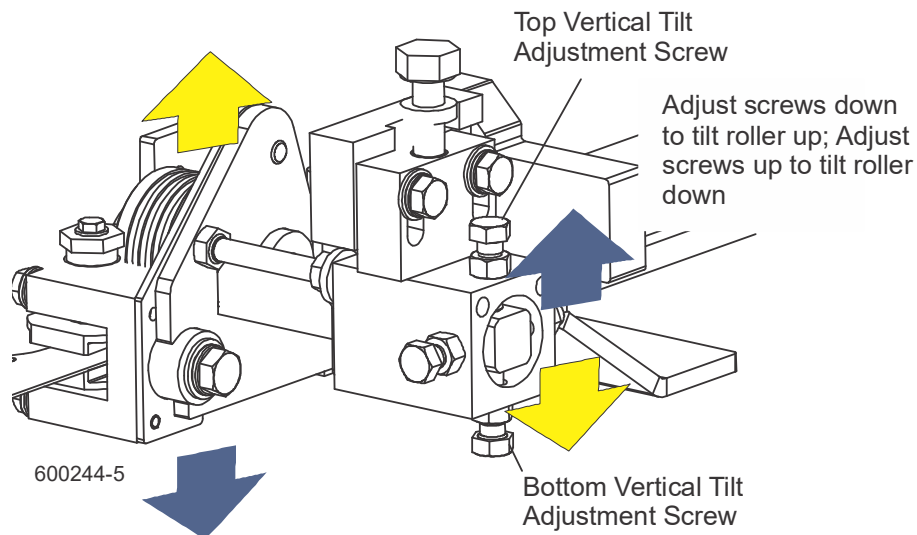

FIG. 7-38 (OPTIONAL HIGH-PERFORMANCE ROLLER/BLOCKS SHOWN)

7. Move the blade guide alignment tool close to the inner blade guide roller assembly and repeat the above steps. Adjust the vertical tilt of the inner blade guide if necessary.
8. After adjusting the vertical tilt of the blade guides, recheck the blade deflection and adjust if necessary.

Blade Guide Horizontal Tilt Adjustment

If the blade guides are tilted in the wrong direction horizontally, the back of the blade may contact the flange as the roller is spinning down, causing it to push the blade away from the guide roller.

1. Remove the blade guide alignment tool from the blade and adjust the blade guide arm halfway in.
2. Remove the clip from the blade guide alignment tool. Place the tool against the face of the outer blade guide roller.

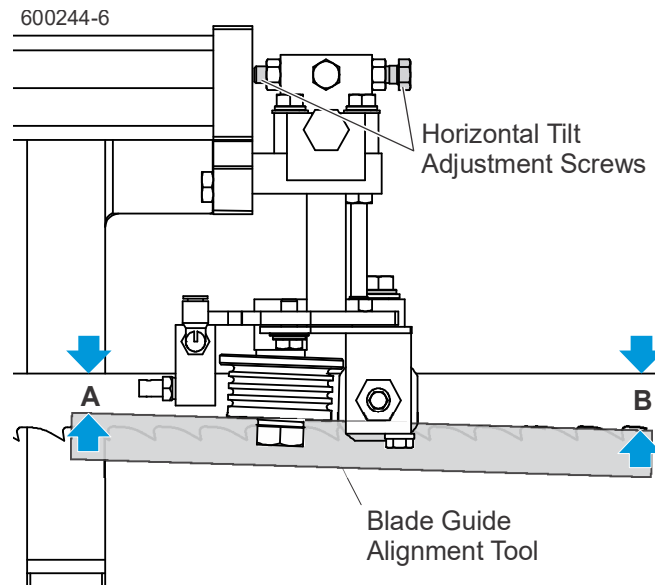

FIG. 7-39 (OPTIONAL HIGH-PERFORMANCE ROLLER/BLOCKS SHOWN)

3. Measure between the back edge of the blade and the tool at the end closest to the inner blade guide ("B").
4. Measure between the back edge of the blade and the other end of the tool ("A").

The roller should be tilted slightly to the left ('A' 1/8" [3 mm] less than 'B' ±1/8" [3 mm]).

5. Loosen the jam nuts on the horizontal tilt adjustment screws. To tilt the roller left, loosen the right screw and tighten left screw. To tilt the roller right, loosen the left screw and tighten the right screw. Tighten the jam nuts and recheck the tilt of the blade. Repeat the above steps for the inner blade guide roller assembly.

NOTE: Once the blade guides have been adjusted, any cutting variances are most likely caused by the blade.

6. Check the blade guide blocks and drive side deflector plate are properly adjusted ([See Section 5.2](#)).

Blade Guide Flange Spacing

Each blade guide must be adjusted so the roller flange is the correct distance from the back edge of the blade. If the flange is too close to or too far from the blade, the sawmill will not cut accurately.

HINT: When adjusting blade guide spacing, loosen the top set screw and one side set screw only. This will ensure horizontal and vertical tilt adjustments are maintained when the adjustment screws are retightened.

1. Measure the distance between the flange on the outer blade guide roller to the back edge of the blade. This distance should measure 1/8" (3.0 mm). Adjust the roller back or forward if necessary.

Loosen the top and one side screw shown. Tap the blade guide forward or backward until properly positioned. Retighten the screws and jam nuts.

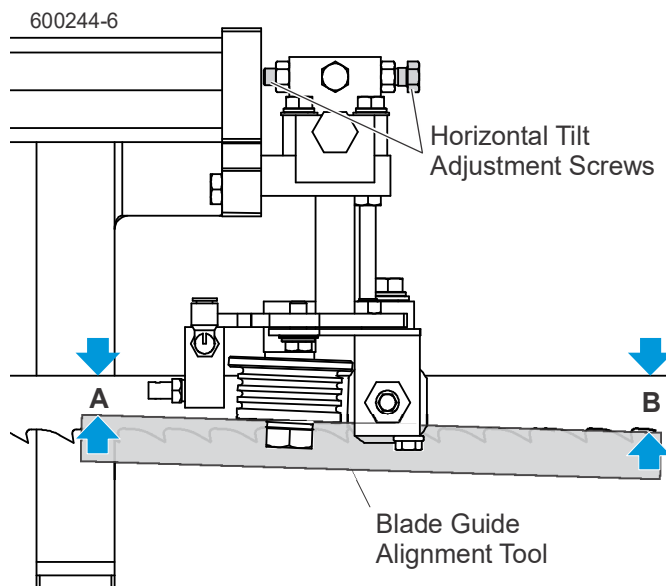

FIG. 7-40 (OPTIONAL HIGH-PERFORMANCE ROLLER/BLOCKS SHOWN)

2. Measure the distance between the flange on the inner blade guide roller to the back edge of the blade. This distance should measure 1/16" (1.5 mm). Adjust the roller back or forward if necessary.

Blade Guide Level (Optional High-Performance blocks only)

Perform the following adjustments to make sure the blade guide assembly is parallel to the blade.

1. Loosen the alignment bar mounting bolt. Use the provided bottom block adjustment tool to adjust the alignment bar up so the bar is close to, but not touching the bottom of the blade. Retighten the alignment bar mounting bolt
2. Check that the gap from the alignment bar to the blade is the same along entire length of the bar. Shine a flashlight behind the blade guide assembly to help you see the gap between the bar and the blade.

Blade Block Adjustment (Optional High-Performance blocks only)

1. Remove the blade and remove the alignment bars from the blade guide assemblies. Install new or reconditioned bottom guide blocks to both blade guide assemblies (leave mounting bolts loose). Use the provided bottom block adjustment tool to lower the bottom block all the way down. Install, tension and track the blade.

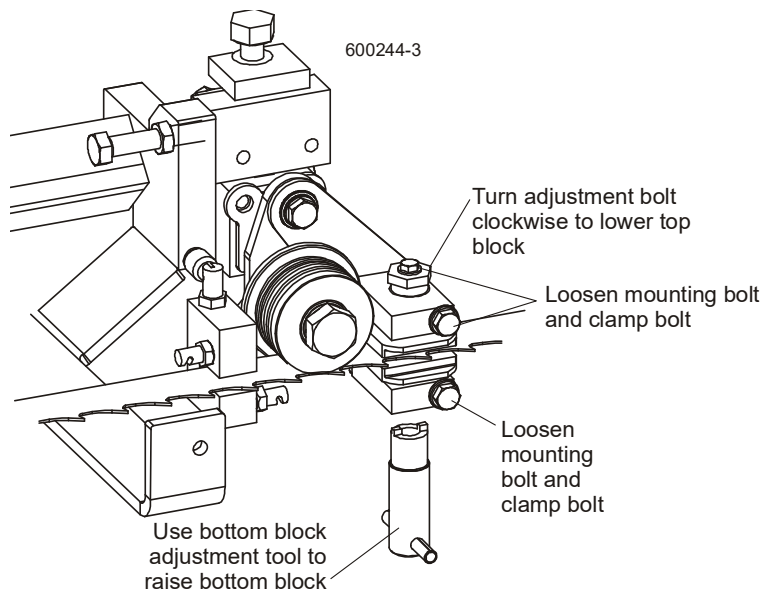
**FIG. 7-41**

2. Use the bottom block adjustment tool to raise the bottom block to 0.008" - 0.010" (0.2-0.25mm) from the blade. Use the provided shim to set the distance from the block to the blade. Tighten the bottom block mounting bolt and clamp bolt.
3. Turn the top block adjustment bolt clockwise to lower the top block to 0.008" - 0.010" (0.2-0.25mm) from the blade (using the shim as a guide). Tighten the top block mounting bolt and clamp bolt.
4. After tightening the clamp bolt, recheck the distance from the top block to the blade and readjust if necessary.

Side Support Alignment

Logs and boards are clamped against the side supports when sawing. The side supports must be square to the bed to ensure square lumber.

1. Swing a side support down and measure between the face of the support and the main bed tube. The distance at the top of the side support ('B') should be equal to or no more than 1/32" (0.8 mm) greater than the distance at the base of the side support ('A'). Adjust the horizontal tilt of the side support if necessary.

Loosen the two adjustment plate mounting bolts. Use a mallet to move the plate until the side support is parallel to the bed tube in the horizontal position. Retighten the mounting bolts.

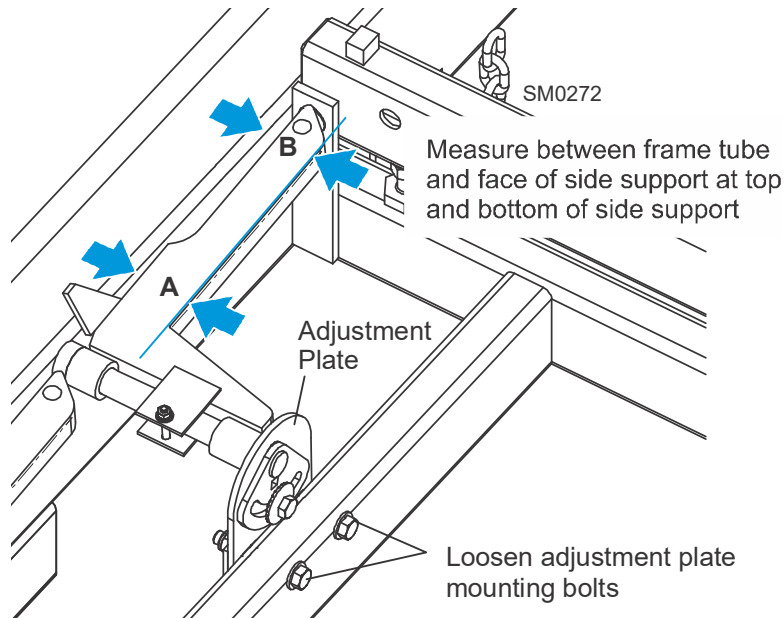

FIG. 7-42

2. Repeat the horizontal check for the remaining side supports. Adjust as necessary.
3. Place square alignment tubes (Part No. S12831 - 2 required) across the bed rails. Swing a side support up so that it is vertical.
4. Pull back at the top of the support to eliminate slack as if a log were being clamped against it.
5. Place a square against the face of the side support. The side support should be square or slightly tilted forward 1/32" (0.8 mm). Adjust the vertical tilt of the side support if necessary.

Loosen the side support mounting bolt. Use a 3/8" ratchet to rotate the pin until the side support is square to the bed.

6. Repeat the vertical check for the remaining side supports and adjust as necessary.

Clamp Stop/Stop Bolt Adjustment

1. Once the side supports are aligned, pivot them down to their horizontal position.
2. Tie a string to the stop block at the first bed rail. Stretch the string toward the rear of the frame and tie to the stop block at the last bed rail.

Loosen the clamp stop bolts and adjust the clamp stop until it touches the string. Loosen the jam nut and adjust the bolt on the middle-rear bed rail until it touches the string.

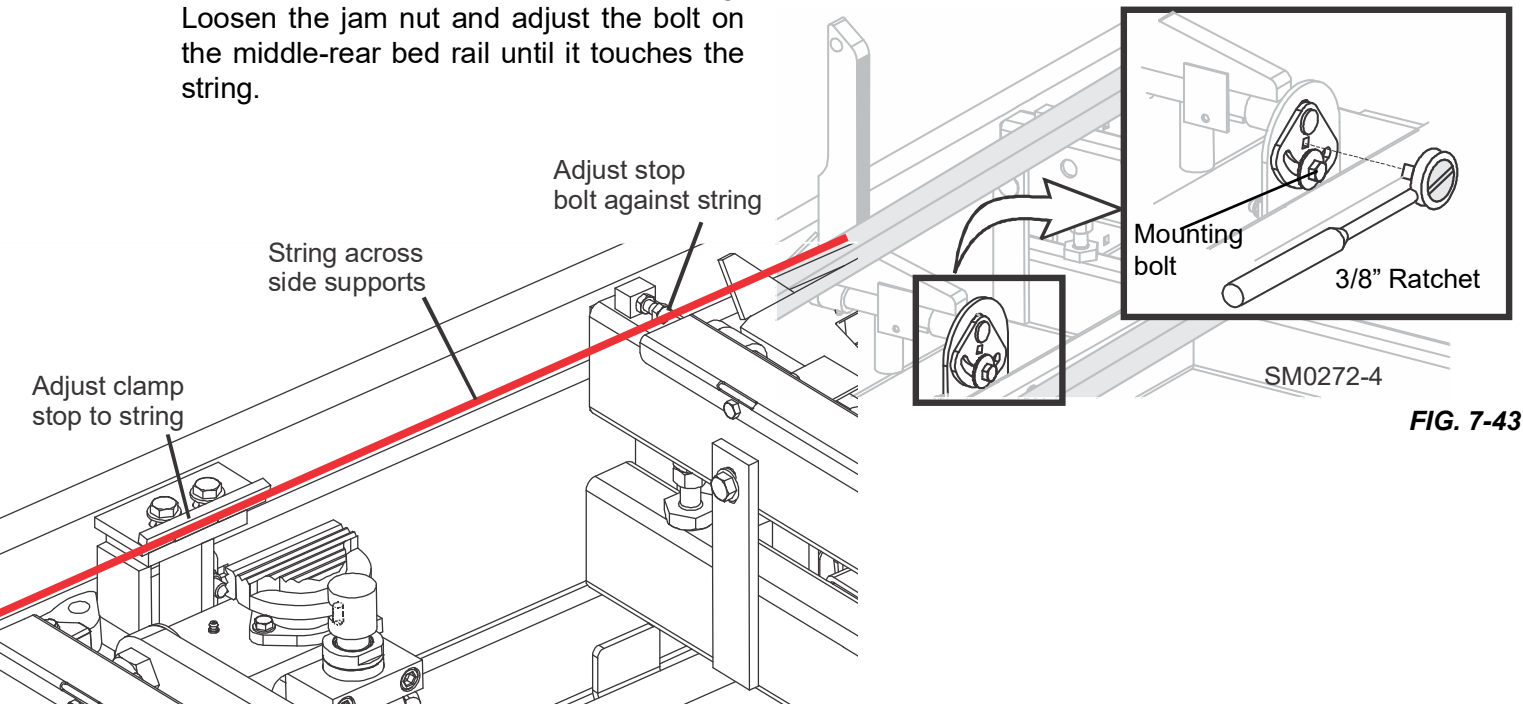
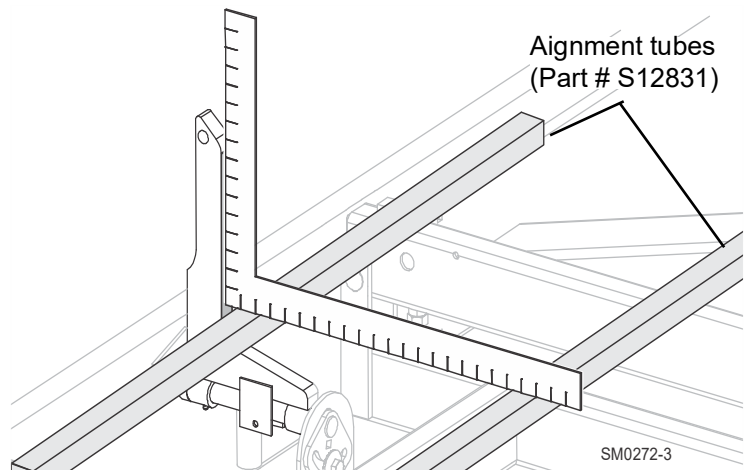

FIG. 7-43

FIG. 7-44

Saw Head Tilt

As the blade enters a wide log or cant, the outside of the saw head will drop down slightly. To compensate for the drop, the saw head is adjusted 1/16" (1.5 mm) higher at the outside.

1. Move the saw carriage so the blade is positioned over a bed rail. Adjust the blade guide arm to 1/2" (13 mm) from full open. The saw head should still be adjusted so the blade is 14 3/4" (375 mm) above the bed rails.

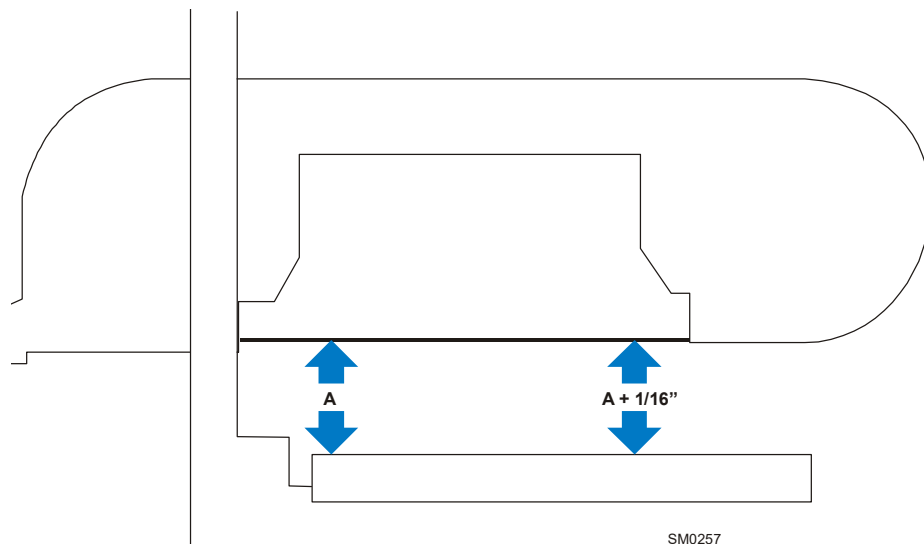

FIG. 7-45

2. Measure from the blade to the bed rail near the outer blade guide assembly.

To adjust the saw head tilt, use the horizontal adjustment nuts. To raise the outside of the saw head, loosen the four inner adjustment nuts 1/4 turn and tighten the four outer nuts. Recheck the measurement from the blade to the bed rails and adjust the horizontal adjustment nuts until the outside of the saw head is 1/16" (1.5mm) higher than the inside.

Blade Height Scale Adjustment

After the entire sawmill has been aligned and all adjustments made, check that the blade height scale indicates the true distance from the blade to the bed rails.

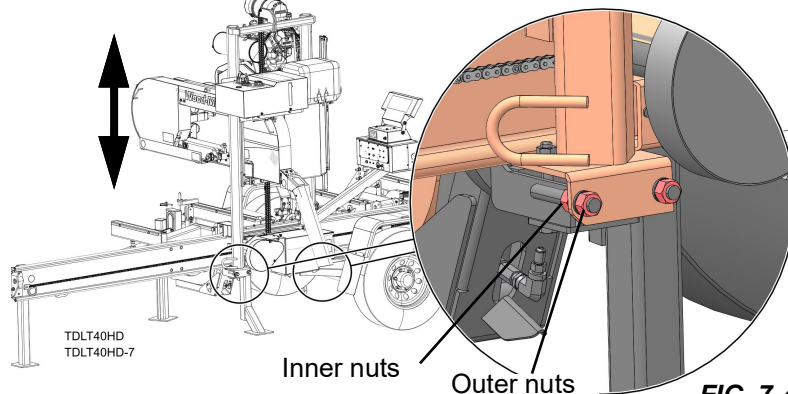

FIG. 7-46

1. Move the saw carriage so the blade is positioned directly above one of the bed rails. Measure from the bottom edge on a down-set tooth of the blade to the top of the bed rail, near the inner blade guide assembly.
2. View the blade height scale with eyes level with the indicator. The scale should indicate the actual distance from the blade to the bed rail. Adjust the indicator if necessary.

Loosen the indicator bracket mounting bolts. Adjust the bracket up or down until the indicator is aligned with the correct mark on the scale (+0 -1/32 [0.8 mm]). Retighten the bracket mounting bolts.

For example, if the measurement from the down-set tooth of the blade to the bed rail was 14 3/4" (375 mm), make sure the indicator reads 14 3/4" (375 mm) on the scale.

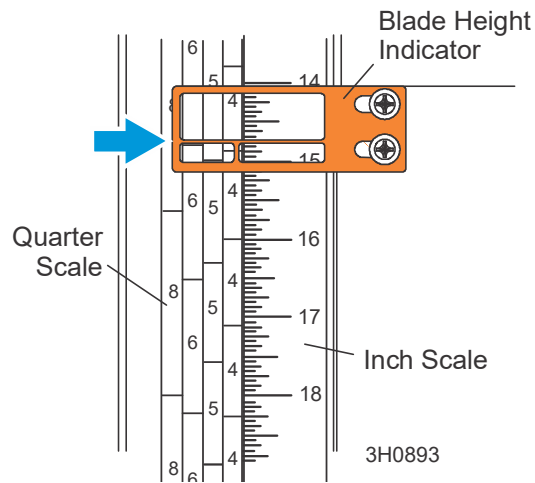

FIG. 7-47

Board Return Bracket

Adjust the board return bracket so the bottom edge is positioned 1/4" (6mm) below the bottom of the blade.

1. With a square cant on the bed rails, lower the blade until it touches the top of the cant. Then raise the saw head 1/4" (6mm) as shown on the scale.
2. Lower the board return arm. The board return bracket should barely touch the top of the cant.
3. Loosen the three bracket mounting bolts to adjust the bracket up or down as necessary.

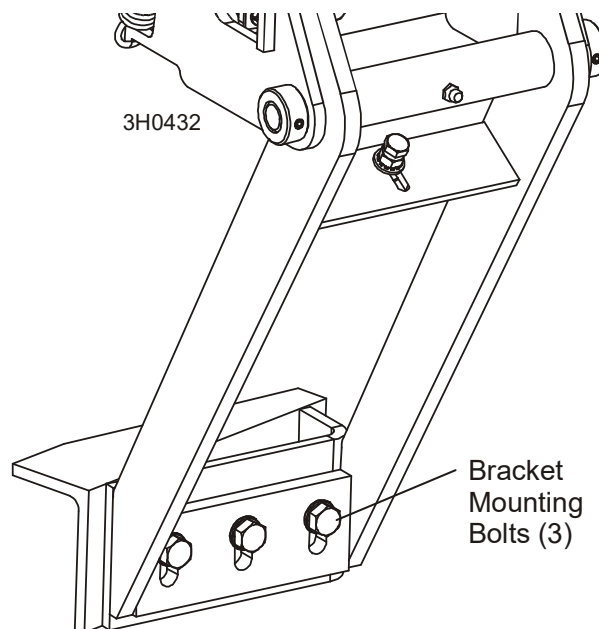
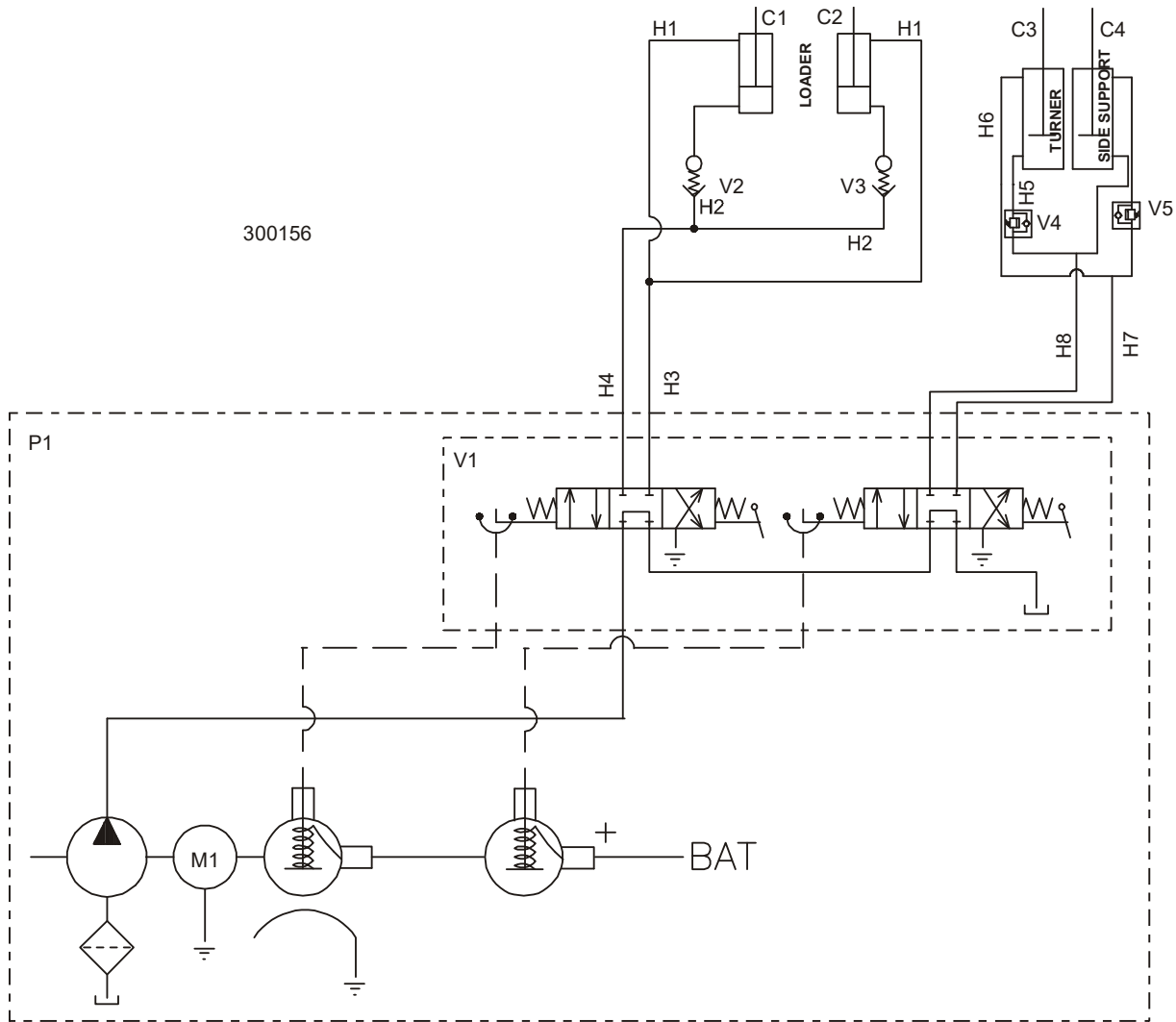

FIG. 7-48

SECTION 8 HYDRAULIC INFORMATION (OPTIONAL LOADER/TURNER)

8.1 Hydraulic Schematic



OPTIONAL HYDRAULIC LOG LOADER/TURNER

8.2 Hydraulic Layout Diagram

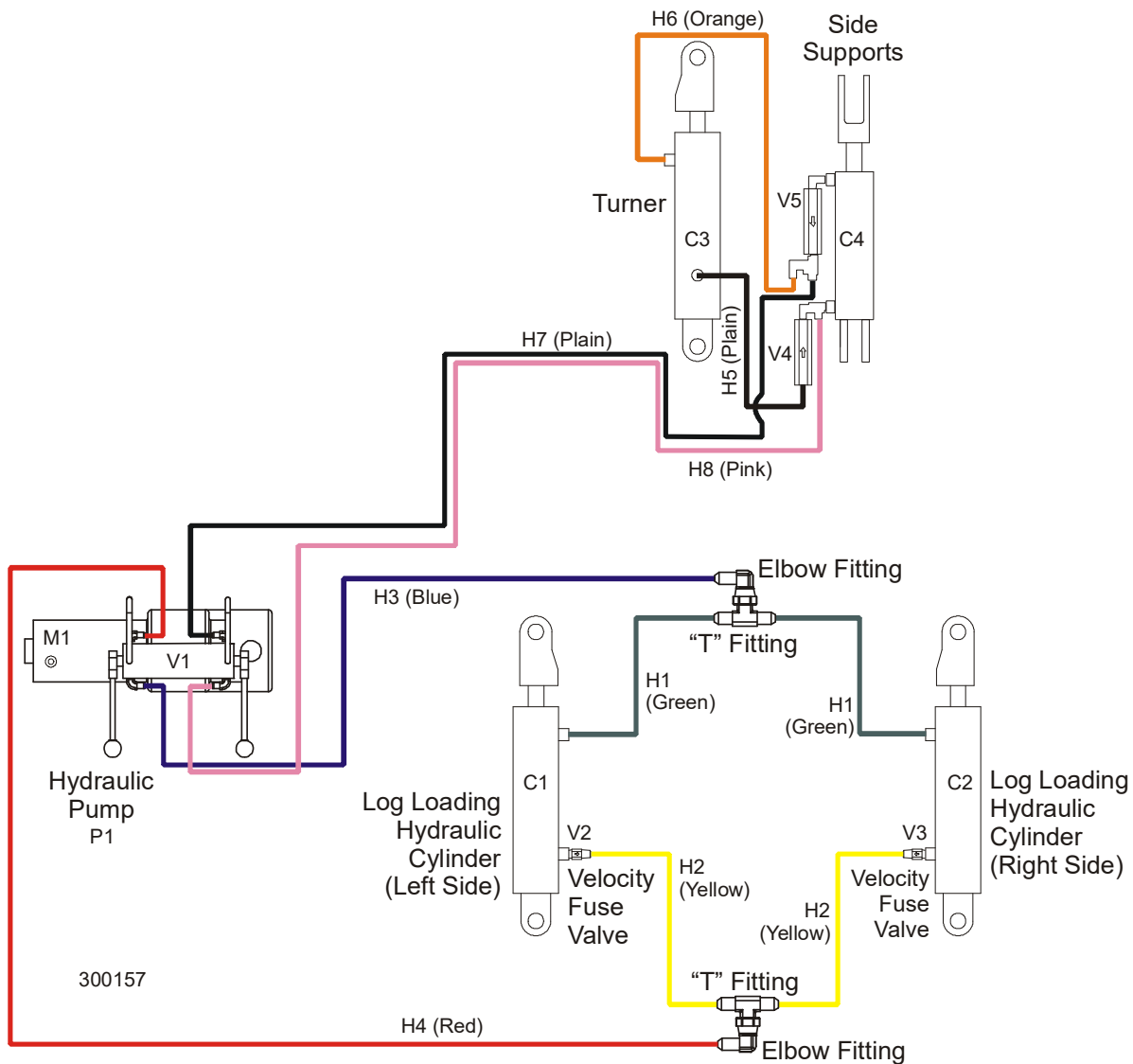

OPTIONAL HYDRAULIC LOADER/TURNER LAYOUT DIAGRAM.

8.3 Hydraulic Components

ID	Wood-Mizer Part.#	Description
C1, C2	P12847	Hyd. Cylinder, 3" Bore X 8" Stroke
C3	P12846	Hyd. Cylinder, 2 1/2" Bore X 8" Stroke
C4	P12845	Hyd. Cylinder, 2" Bore X 6" Stroke
M1	052807	Motor, Iksra Hydraulic Pump
P1	025713	Hydraulic Pump, With Motor
V1		Valve, 4-Way Hydraulic
V2, V3	015750	Valve, Hydraulic 5GPM Velocity Fuse
V4, V5	A09207	Sequence Valve

8.4 Hydraulic Hoses

ID	Color Code	LENGTH "A"	Application	Wood-Mizer Part No.
H1	Green	62"	1/4" Loading Arm Branch Top	018020
H2	Yellow	64"	1/4" Loading Arm Branch Base	018021
H3	Blue	148"	1/4" Loading Arm Top	
H4	Red	158"	1/4" Loading Arm Bottom	
H5	Plain	27"	1/4" Log Turner Base	P12535
H6	Orange	18"	1/4" Log Turner Top	015704
H7	Plain	220"	1/4" Side Support Top	
H8	Pink	206"	1/4" Side Support Base	

INDEX

A

alignment
 lower track rollers 7-19
 main bed rails 7-21
 slide pad adjustment 7-19

B

battery
 troubleshooting problems 6-3

blade
 breakage, troubleshooting 6-1
 installation 3-7
 tensioning 3-8
 tracking 3-9

blade guide arm
 operation 4-8

C

chain
 feed tension 5-22
 maintenance 5-9
 up/down tension 5-19

clutch/brake lever
 operation 4-9

H

hydraulic
 component list 8-3
 fluid level 5-27
 hose list 8-4
 layout diagram 8-2
 schematic 8-1

L

leveling logs 4-6

loading logs 4-4

M

maintenance
 blade guide 5-2
 blade tensioner 5-10
 blade wheel belts 5-10, 5-12
 brake adjustment 5-13
 brake strap 5-13
 carriage track/wipers 5-4, 5-5
 drive bearing 5-18
 drive belt 5-14
 hydraulic system 5-27
 mast rails 5-6, 5-7
 miscellaneous 5-9
 part wear life 5-1
 power feed 5-22
 sawdust removal 5-4
 up/down 5-19

O

operation
 edging 4-14
 sawing 4-13

P

power feed
 mechanical troubleshooting test 6-11
 operation 4-12
 preliminary troubleshooting test 6-10
 speed adjustment 4-11
 troubleshooting problems 6-6

S

safety

- lockout procedure 2-3
- symbols 2-4

Safety Instructions 2-1

scale

- blade height operation 4-16
- inch height 4-16
- quarter inch 4-16

service information

- branch locations 1-3
- customer & sawmill ID 1-5
- general contact info 1-2

setup

- portable sawmill 3-3
- stationary sawmill 3-1

T

tensioner

- maintenance 5-10

troubleshooting 6-1

- electrical problems 6-3
- hydraulic problems 6-12
- motor driver module 6-8
- power feed problems 6-6
- sawing problems 6-1

turning logs 4-6

U

up/down

- operation 4-7
- troubleshooting problems 6-3

W

water lube

- operation 4-18