

Wood-Mizer® Sawmill
Safety, Setup, Operation, &
Maintenance Manual

LT15 Start

rev. A1.00-A1.04

Safety is our #1 concern!

November 2017

Models Affected:

LT15EH15NS
LT15G14S



WARNING! Read and understand this manual before using this machine.

California

Proposition 65 Warning



WARNING: Breathing gas/diesel engine exhaust exposes you to chemicals known to the State of California to cause cancer and birth defects or other reproductive harm.

Always start and operate the engine in a well-ventilated area.
If in an enclosed area, vent the exhaust to the outside.
Do not modify or tamper with the exhaust system.
Do not idle the engine except as necessary.

For more information go to www.P65warnings.ca.gov.



WARNING: Drilling, sawing, sanding or machining wood products can expose you to wood dust, a substance known to the State of California to cause cancer. Avoid inhaling wood dust or use a dust mask or other safeguards for personal protection.

For more information go to www.P65Warnings.ca.gov/wood.

Active Patents assigned to Wood-Mizer, LLC

Wood-Mizer, LLC has received patents that protect our inventions which are a result of a dedication to research, innovation, development, and design. Learn more at: woodmizer.com/patents

©2026 Wood-Mizer LLC

Printed in the United States of America, all rights reserved. No part of this manual may be reproduced in any form by any photographic, electronic, mechanical or other means or used in any information storage and retrieval system without written permission from

Wood-Mizer, LLC
8180 West 10th Street
Indianapolis, Indiana 46214

SECTION 1 INTRODUCTION

1.1 About This Manual 1-1
 1.2 Getting Service..... 1-1
 1.3 Specifications 1-1
 1.4 Options and Accessories 1-1

SECTION 2 GENERAL SAFETY

2.1 Safety Symbols 2-1
 2.2 Safety Instructions..... 2-1
 Observe ALL Safety Instructions..... 2-1
 2.3 Electrical Lockout Procedures 2-3

SECTION 3 SAWMILL ASSEMBLY

3.1 Unpacking 3-1
 3.2 Leg Assembly 3-2
 3.3 Bed Section Assembly 3-2
 3.4 Clamp Assembly 3-4
 3.5 Saw Carriage Assembly 3-4
 3.6 Miscellaneous..... 3-5

SECTION 4 SAWMILL SETUP

4.1 Sawmill Setup 4-1
 4.2 Carriage Locking Pins..... 4-2
 4.3 Installing a Blade 4-2
 4.4 Tensioning The Blade 4-3
 4.5 Tracking The Blade..... 4-3
 4.6 Alignment..... 4-4
 4.7 Starting The Engine 4-4

SECTION 5 SAWMILL ALIGNMENT

5.1 Routine Alignment Procedure..... 5-1
 Blade Installation 5-1
 Saw Head Tilt..... 5-1
 Blade Guide Arm Alignment 5-2
 Blade Guide Vertical Tilt Alignment..... 5-3
 Blade Guide Horizontal Tilt Adjustment..... 5-4
 Blade Guide Flange Spacing..... 5-5
 Side Support Alignment..... 5-5
 Blade Height Scale Adjustment..... 5-6
 5.2 Complete Alignment Procedure..... 5-6
 Frame Setup 5-6
 Blade Installation..... 5-7
 Saw Head Tilt See “Saw Head Tilt” on page 5-1..... 5-7
 Blade Wheel Alignment..... 5-7
 Blade Guide Installation 5-10
 Blade Guide Arm Alignment See “Blade Guide Arm Alignment” on page 5-25-10
 Blade Guide Deflection..... 5-10

SECTION 6 SAWMILL OPERATION

6.1 Loading, Turning And Clamping Logs6-1
6.2 Up/Down Operation6-2
6.3 Blade Guide Arm Operation.....6-2
6.4 Clutch Operation6-3
6.5 Cutting The Log6-3
6.6 Edging.....6-4
6.7 Blade Height Scale6-4
6.8 Water Lube Operation6-5
6.9 Loading & Transporting the Sawmill.....6-5

SECTION 7 MAINTENANCE

7.1 *Wear Life*..... 7-1
7.2 Blade Guides7-1
7.3 Sawdust Removal7-1
7.4 Carriage Track, Wiper & Scrapers7-1
7.5 Vertical Mast Rails7-2
7.6 Miscellaneous7-3
7.7 Blade Wheel Belts7-3
7.8 Drive Belt Adjustment.....7-3
7.9 Up/Down System.....7-4
7.10 Maintenance chart7-6

7.10 MAINTENANCE LOG 7-6

SECTION 8 TROUBLESHOOTING GUIDE

8.1 Sawing Problems8-1

Wood-Mizer® LLC Limited Product Warranty



Wood-Mizer LLC ("Warrantor"), an Indiana corporation with its principal place of business at 8180 West Tenth Street, Indianapolis, IN 46214-2400 USA, warrants to the purchaser ("Purchaser") that for the time periods specifically stated herein and subject to the terms, conditions and limitations stated herein, the equipment manufactured by the Warrantor will be free from defects in material and workmanship attributable to Warrantor so long as, during the warranty periods stated herein, the equipment is installed, operated and maintained in accordance with the instructions provided by Warrantor.

PRODUCT	MODEL CLASS	LENGTH OF WARRANTY		EFFECTIVE DATE
		USA & CANADA	NON USA & CANADA	
Portable Sawmills, Resaws, Edgers	LT, LX, HR, EG	Two years	One year	Date of purchase
Portable Sawmills with Chassis	LT28, LT35, LT40, LT50, LT70, LX450	Two years, excluding the chassis, which chassis shall have a five year warranty	One year	
Industrial Sawmills, Resaws, Edgers	WM, HR, EG, TVS, SVS	One year	One year	Date of purchase or date of installation / training (if applicable), whichever occurs first, not to exceed 6 months from date of purchase
TITAN Industrial	WB, TV, HR, EG, EA, MR	One year	One year	
Material Handling	TWC, IC, TD, LD, GC, CR, CB, CC	One year	One year	
Blade Maintenance Equipment	BMS, BMT, BMST	One year	One year	Date of purchase
Options and Accessories	Various	One year*	One year*	
Moulders, Extractors	MP, MD	Two years	One year	
Kilns	KS, KD	One year	One year	
Slab Flatteners	MB	Two years	One year	
Pallet Equipment	PD, PC	One year	One year	
Log Splitters	FS	One year	One year	
Replacement Parts	Various	90 days	90 days	

* Warranty on Options will match the warranty on the primary equipment when purchased on same invoice.

Exclusions from 90 Day, Limited One Year and Two Year Warranty

Warrantor shall have no responsibility under this warranty for any wear components, including, but not limited to: belts, blade guides, blades, electric motor brushes, drum switches, filters, fuses, hoses, bearings (excluding cylindrical drive bearings), bushings, cable carriers, and spark plugs. All wear components are furnished "as is", without any warranty from Warrantor. This limited warranty does not cover any defects caused by misuse, negligence, alterations, damage due to overload, abnormal conditions, excessive operation, accident, or lack of performance of normal maintenance services.

Several components which are used in the manufacture of the equipment but not manufactured by Warrantor such as cant hooks, power plants, laser sights, batteries, tires, and trailer axles have warranties provided by the original equipment manufacturer (written copies available upon request). Warrantor does not separately warrant such items. Components or equipment manufactured by third parties are not covered by this warranty. Warrantor, however, will provide reasonable assistance to the Purchaser to make claims against any warranties applicable to such component parts as provided by such original equipment manufacturers. Components or equipment manufactured by third parties are not covered by this Warranty.

Five Year Limited Chassis Warranty

The limited five year chassis warranty described above, DOES NOT extend to (a) any damage stemming from accident, improper towing, overload, abuse, misuse, abnormal conditions, negligence, excessive operation, or lack of maintenance, (b) rust caused by exposure to corrosive atmospheric conditions, or (c) the sawmill head, carriage, axle, brakes, or any hydraulic or electrical components attached to the chassis.

Warrantor's Obligations as To Defects

In the event that the equipment fails to perform due to defective materials or workmanship attributable to Warrantor under normal use and service within the established warranty period, Purchaser's sole and exclusive remedy and Warrantor's sole liability shall be to replace or repair, in Warrantor's sole and subjective discretion, any defective part at Warrantor's principal place of business without cost to the Purchaser if such defect exists. The determination of whether a product is defective shall be made by Warrantor in Warrantor's sole and subjective discretion. The Purchaser must notify Warrantor prior to shipping any defective part. Warrantor, at its sole discretion, may cover expenses incurred in shipping the defective part to Warrantor for evaluation; provided, however, that Warrantor will not be responsible for labor, travel time, mileage, removal, installation or incidental or consequential damages. However, any part in excess of 140 pounds must be returned by the Purchaser, to the Warrantor's nearest authorized facility at the Purchaser's expense, if return is requested by Warrantor. Warrantor shall have a reasonable time within which to replace or repair the defective part. If Warrantor determines that the product is not defective under the terms of this warranty in Warrantor's sole and subjective discretion, then Purchaser shall be responsible for any expenses incurred by Warrantor in returning the equipment to the Purchaser.

Limitations and Disclaimers of Other Warranties

EXCEPT FOR THE EXPRESS WARRANTY PROVISIONS STATED ABOVE, WARRANTOR DISCLAIMS ALL WARRANTIES, EXPRESS AND/OR IMPLIED, INCLUDING WITHOUT LIMITATION, THE IMPLIED WARRANTIES OF MERCHANTABILITY, AND FITNESS FOR A PARTICULAR PURPOSE, NON-INFRINGEMENT AND TITLE. No representation or other affirmation of fact by representatives of Warrantor, whether verbal or in writing, including photographs, brochures, samples, models, or other sales aids, shall constitute a warranty or other basis for any legal action against Warrantor. There are no other representations, promises, agreements, covenants, warranties, guarantees, stipulations or conditions, express or implied, by Warrantor except as expressly set forth herein. THE ORIGINAL PURCHASER AND ANY INTENDED USER OR BENEFICIARY OF THIS EQUIPMENT, SHALL NOT BE ENTITLED TO RECOVER ANY INDIRECT, SPECIAL, PUNITIVE, EXEMPLARY, CONSEQUENTIAL, SPECIAL, OR INCIDENTAL DAMAGES OR LOSSES, INCLUDING BUT NOT LIMITED TO, DAMAGES OF LOST PRODUCTION, LOST REVENUE, LOST PRODUCT, LOST PROFITS, LOST BUSINESS, LOSS OF USE, LOSS OF GOODWILL, OR BUSINESS INTERRUPTION, FROM WARRANTOR FOR ANY REASON WHATSOEVER INCLUDING WITHOUT LIMITATION WARRANTY OR DEFECT IN THE PRODUCT REGARDLESS OF THE SOLE, JOINT AND/OR CONCURRENT NEGLIGENCE, BREACH OF CONTRACT, BREACH OF WARRANTY, STRICT LIABILITY IN TORT OR STATUTORY CLAIMS OR OTHER LEGAL FAULT OR RESPONSIBILITY OF EITHER WARRANTOR OR PURCHASER OR ITS EMPLOYEES OR AGENTS. Warrantor does not warrant that its equipment meets or complies with the requirements of any particular safety code or governmental requirements.

Defective items replaced under the terms of this warranty become the property of Warrantor.

Design Changes

Warrantor reserves the right to change the design of its products from time to time without notice and without obligation to make corresponding changes in or to its products previously manufactured.

Rights of Purchasers

The validity and effect of this limited warranty as well as its interpretation, operation and effect, shall be determined exclusively by the principles of law and equity of the State of Indiana, USA. This limited warranty gives Purchaser specific legal rights. Purchaser may also have other rights, which may vary from state to state. Some states may not allow limitations as to the duration of implied warranties or to the exclusion or limitation of incidental or consequential damages, so some of the limitations and exclusions detailed set forth above may not apply. In the event that any one or more of the provisions of this warranty shall be or become invalid, illegal or unenforceable in any respect, the validity, legality and enforceability of the remaining provisions of this warranty shall not be affected thereby.

Interpretations

This Warranty constitutes the entire warranty agreement between Warrantor and Purchaser and supersedes any prior understandings or agreements pertaining to the same subject matter. This warranty cannot be amended except in writing which refers to this warranty which is signed by both Warrantor and Purchaser.

SECTION 1 INTRODUCTION

1.1 About This Manual

This manual replaces any previous information received on your Wood-Mizer® equipment.

The information and instructions in this manual do not amend or extend the limited warranties for the equipment given at the time of purchase.

1.2 Getting Service

For contact information, sales, service, parts, and additional manuals, sign into your account on <https://woodmizer.com>, or call inside the USA: 1-800-553-0182 or from outside the USA: 317-271-1542

1.3 Specifications

Equipment specification are included in the Online Manuals, which are found at <https://apps.woodmizer.com/Manuals/Manuals.aspx?parent=0>.

1.4 Options and Accessories

Portable Sawmills, LT15S

Your Wood-Mizer product may have options that can be added to the machine or accessories available to purchase. Different power configurations are also available.

Option: Your specific product can have accessories installed at the factory, or installed in the field. For example, a sawmill might have a debarker or power-feed option.

Accessory: Your specific product may have accessories added to the machine that are not available to be installed at the factory. They may only be installed in the field. For example, a sawmill might have a bed extension or a Shingle/Lap Sider accessory.

Power Options: Your specific product power option is detailed based on the specific product number purchased.

This product has the following options available:

Documentation	Name	Part Number	Type
2454	E15 International		Engine
2307	G14 Kohler		Engine

SECTION 2 GENERAL SAFETY

2.1 Safety Symbols

The following symbols and signal words call your attention to instructions concerning your personal safety. Be sure to observe and follow these instructions.

 **DANGER!** indicates an imminently hazardous situation which, if not avoided, will result in serious injury or death.

 **WARNING!** suggests a potentially hazardous situation which, if not avoided, could result in serious injury or death.

 **CAUTION!** refers to potentially hazardous situations which, if not avoided, may result in minor or moderate injury or damage to equipment.

NOTICE indicates vital information.

2.2 Safety Instructions

OWNER/OPERATOR'S RESPONSIBILITY

The procedures listed in this manual may not include all ANSI, OSHA, or locally required safety procedures. **It is the owner/operator's responsibility and not Wood-Mizer LLC to ensure all operators are properly trained and informed of all safety protocols.** Owner/Operators are responsible for following all safety procedures when operating and performing maintenance to the equipment.

Observe ALL Safety Instructions

NOTICE Read the entire Operator's Manual before operating this equipment.

Note all safety warnings throughout this manual and those posted on the machine.

Be able to access this manual at all times while operating this equipment.

Read additional manufacturer's manuals and observe their applicable safety instructions.

Only persons who have read and understood the entire operator's manual should operate this equipment.

This equipment is not intended for use by or around children.

It is the owner/operator's responsibility to comply with all applicable federal, state, and local laws, rules, and regulations regarding the ownership, operation, and transporting your equipment.

Operators should become thoroughly familiar with and comply with these applicable laws for operating and transporting equipment.

 **WARNING!** Clean sawdust from all guards, vents, control boxes, or any area where sawdust may gather **after every shift.** Failure to do so may result in fire, causing death or serious injury.

WEAR SAFETY CLOTHING

 **WARNING!** Secure all loose clothing and jewelry before operating the mill.

Always wear eye, ear, and foot protection when operating or servicing the mill.

Wear hand protection while servicing the mill blades.

Wear respiratory protection when sawing woods that require it. (It is up to the sawyer to know which woods require respiratory protection.)

HANDLE FUEL/LUBRICANTS SAFELY

 **DANGER!** Due to the flammable nature of fuel and oil, never smoke, weld, grind or allow sparks near your engine or storage tanks, especially during times of fueling.

Do not allow fuel to spill on a hot engine during fueling operations or otherwise.

 **WARNING!** Store gasoline away from sawdust and other flammable materials.

Do not use flammable fuels or liquids such as diesel fuel. Use ONLY water and Wood-Mizer Lube Additive with the water lube accessory.

MILL SETUP

 **DANGER!** Do not operate the mill without all covers and guards in place.

 **WARNING!** Set up the mill on solid, level ground.

Use a minimum of three people (four recommended) to safely load or unload the sawmill from a pickup truck.

Do not lift the sawmill using ropes, cables or chains, etc. The weight is off balanced and may cause the mill to fall.

Keep all persons out of the area between the frame rails while loading and unloading the sawmill.

CHECK SAWMILL BEFORE OPERATION

 **DANGER!** Ensure all guards and covers are in place and secured before operating or towing the sawmill.

Use the safety retainer pin and cable to fasten blade housing covers.

 **WARNING!** Do not operate the sawmill without the bed end retaining brackets properly installed; the saw head may fall from the log bed. Failure to follow this may result in serious injury or death.

KEEP PERSONS AWAY

 **DANGER!** Keep all persons out of the path of moving equipment and logs when operating sawmill or loading and turning logs.

Ensure the blade is disengaged and all persons are out of the path of the blade before starting the engine or motor.

KEEP HANDS AWAY

 **DANGER!** Remove power before clearing debris or any other maintenance activity.

Disengage the blade and shut off the sawmill engine before changing the blade.

WARNING! Avoid contact with any hot parts (motors).

Allow the system to cool sufficiently before beginning any service function, including debris removal.

Avoid contact with sharp edges of the cutting blades.

Stay a safe distance from rotating members (shafts, pulleys, fans, etc.) and ensure loose clothing or long hair does not engage rotating members

Do not spin the blade wheels by hand. Spinning the blade wheels by hand may result in serious injury.

Disengage the clutch/brake mechanism whenever the sawmill is not cutting.

Do not adjust the engine drive belt with the engine running.

Keep hands, feet, etc., clear of exiting sawdust chute when operating sawmill.

UP/DOWN SYSTEM SAFETY

WARNING! When servicing the saw head or areas near the saw head, always secure the saw head with a chain with a minimum of 1900 lbs. working load capacity. Alternatively, the saw head can be secured by placing a sturdy wood block between the saw head and sawmill frame. See Fig. 2-1.

Release pressure from the up/down assist prior to performing any service to the assembly. Parts are under tension and may fly apart.

Do not disassemble the pressurized cylinder. Parts are under pressure and may fly apart or damage the cylinder.

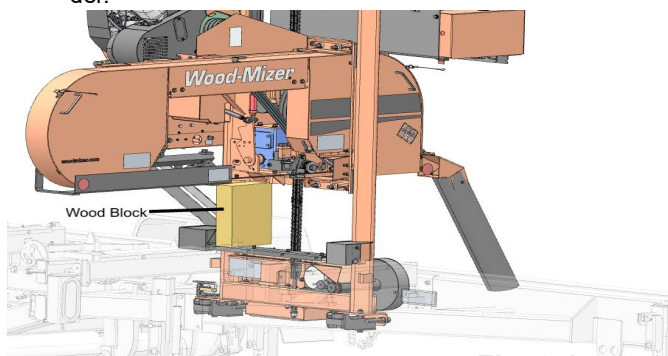

Fig. 2-1

KEEP SAFETY LABELS IN GOOD CONDITION

NOTICE Ensure that all safety decals are clean and readable. Replace all damaged safety decals to prevent personal injury or damage to the equipment. Contact your local distributor, or call your Customer Service Representative to order more decals.

NOTICE If replacing a component that has a safety decal affixed to it, ensure the new component also has the safety decal affixed.

KEEP MILL AND AREA AROUND MILL CLEAN

WARNING! Maintain a clean and clear path for all necessary movement around the mill and material stacking areas.

Do not allow children in the area of the mill. Failure to follow this may result in death or serious injury.

GAS OR DIESEL ENGINE OPERATION

DANGER! Operate your engine/machine only in well ventilated areas.

Do not operate an engine with a fuel or oil leak.

WARNING! Do not operate engine without proper and operational spark arrester/muffler.

DISPOSE OF WOOD BY-PRODUCTS PROPERLY

NOTICE Properly dispose of all wood by-products, including sawdust, chips, and other debris, including operation waste such as oil, filters, etc.

WORKING WITH BATTERIES

DANGER! Batteries expel explosive gases; keep sparks, flames, burning cigarettes, or other ignition sources away at all times. Failure to follow this will result in serious injury or death.

WARNING! Always wear safety goggles and a face shield when working near batteries. Failure to follow this could result in serious injury or death.

Wash hands after handling batteries to remove possible lead, acid, or other contaminants. Failure to follow this could result in serious injury or death.

Charge the battery in a well ventilated area. Failure to follow this could result in serious injury or death.

Do not attempt to charge a frozen battery. Failure to follow this could result in serious injury or death.

CAUTION! Do not overcharge the battery. Overcharging may reduce the overall service life of the battery.

Ensure the battery is fully charged before transporting the sawmill. If the battery is not fully charged, excessive vibration could reduce the overall service life of the battery.

NOTICE When working with batteries, use extreme care to avoid spilling or splashing electrolyte (dilute sulfuric acid) as it can destroy clothing and burn the skin.

EMERGENCY TREATMENT FOR CONTACT WITH BATTERY COMPONENTS (LEAD/SULFURIC ACID) per SDS (Safety Data Sheet):

EYE CONTACT	Sulfuric Acid and Lead: Flush eyes immediately with large amounts of water for at least 15 minutes while lifting lids. Seek immediate medical attention.
SKIN CONTACT	Sulfuric Acid: Flush affected area(s) with large amounts of water using deluge emergency shower, if available, shower for at least 15 minutes. Remove contaminated clothing, including shoes. If symptoms persist, seek medical attention. Wash contaminated clothing before reuse. Discard contaminated shoes. Lead: Wash immediately with soap and water.
INGESTION	Sulfuric Acid: Administer large amounts of water. Do NOT induce vomiting or aspiration into the lungs may occur and can cause permanent injury or death; consult physician.
INHALATION	Sulfuric Acid: Remove to fresh air immediately. If not breathing, give artificial respiration. If breathing is difficult, give oxygen. Consult a physician. Lead: Remove from exposure, gargle, wash nose and lips; consult physician.

2.3 Electrical Lockout Procedures

RULES FOR USING LOCKOUT PROCEDURE

The equipment shall be locked out to protect against accidental or inadvertent operation when such operation could cause injury to personnel. Do not attempt to operate any switch or valve bearing a lock.

LOCKOUT PROCEDURES MUST BE USED DURING, BUT NOT LIMITED TO:

- Changing or adjusting blades
- Unjamming operations
- Cleaning
- Mechanical repair
- Electrical maintenance
- Retrieval of tools/parts from work area
- Activities where guards or electrical panel guard is open or removed

MAINTENANCE HAZARDS INCLUDE, BUT NOT LIMITED TO:

- Blade contact
- Pinch points
- Kickbacks
- Missiles (thrown blades/wood chips)
- Electrical

FAILURE TO LOCKOUT MAY RESULT IN, BUT NOT LIMITED TO:

- Cut
- Crush

- Blindness
- Puncture
- Electrocution
- Serious injury and death
- Amputation
- Burn
- Shock

TO CONTROL MAINTENANCE DANGERS:

- Lockout procedures must be followed (see **OSHA regulation 1910.147**).
- Never rely on machine stop control for maintenance safety (emergency stops, on/off buttons, interlocks).
- Do not reach into moving blades or feed systems. Allow all coasting parts to come to a complete stop.
- Electrical power supply and air supply must both be locked out.
- Where established lockout procedures cannot be used (electrical troubleshooting or mechanical dynamic troubleshooting), alternative effective protective techniques shall be employed which may require special skills and planning.
- Always follow safe operations practices in the workplace.

EQUIPMENT LOCKOUT PROCEDURE

Lockout procedures per OSHA regulation 1910.147, appendix A:

GENERAL

The following simple lockout procedure is provided to assist owner/operators in developing their procedures so they meet the requirements of **OSHA regulation 1910.147**. When the energy isolating devices are not lockable, tagout may be used, provided the owner/operator complies with the provisions of the standard which require additional training and more rigorous periodic inspections. When tagout is used and the energy isolating devices are lockable, the owner/operator must provide full operator protection (see OSHA regulation 1910.147, paragraph (c)(3)) and additional training and more rigorous periodic inspections are required. For more complex systems, more comprehensive procedures may need to be developed, documented, and utilized.

PURPOSE

This procedure establishes the minimum requirements for the lockout of energy isolating devices whenever maintenance or servicing is done on machines or equipment. It shall be used to ensure that the machine or equipment is stopped, isolated from all potentially hazardous energy sources and locked out before personnel perform any servicing or maintenance where the unexpected energization or start-up of the machine or equipment or release of stored energy could cause injury.

COMPLIANCE WITH THIS PROGRAM

All personnel are required to comply with the restrictions and limitations imposed upon them during the use of lockout. The authorized personnel are required to perform the lockout in accordance with this procedure. All operators, upon observing a machine or piece of equipment which is locked out to perform servicing or maintenance shall not attempt to start, energize, or use that machine or equipment.

SEQUENCE OF LOCKOUT

1. Notify all affected personnel that servicing or maintenance is required on a machine or equipment and that the machine or

equipment must be shut down and locked out to perform the servicing or maintenance.

2. The authorized employee shall refer to the company procedure to identify the type and magnitude of the energy that the machine or equipment utilizes, shall understand the hazards of the energy, and shall know the methods to control the energy.
3. If the machine or equipment is operating, shut it down by the normal stopping procedure (depress the stop button, open switch, close valve, etc.).
4. De-activate the energy isolating device(s) so that the machine or equipment is isolated from the energy source(s).
5. Lock out the energy isolating device(s) with assigned individual lock(s).
6. Stored or residual energy (such as that in capacitors, springs, elevated machine members, rotating flywheels, hydraulic systems, and air, gas, steam, or water pressure, etc.) must be dissipated or restrained by methods such as grounding, repositioning, blocking, bleeding down, etc.
7. Ensure that the equipment is disconnected from the energy source(s) by first checking that no personnel are exposed, then verify the isolation of the equipment by operating the push button or other normal operating control(s) or by testing to make certain the equipment will not operate.



CAUTION! Return operating control(s) to neutral or "off" position after verifying the isolation of the equipment.

8. The machine or equipment is now locked out.

RESTORING EQUIPMENT TO SERVICE

When the servicing or maintenance is completed and the machine or equipment is ready to return to normal operating condition, the following steps shall be taken.

1. Check the machine or equipment and the immediate area around the machine to ensure that nonessential items have been removed and that the machine or equipment components are operationally intact.
2. Check the work area to ensure that all personnel have been safely positioned or removed from the area.
3. Verify that the controls are in neutral.
4. Remove the lockout devices and re-energize the machine or equipment.

NOTE: The removal of some forms of blocking may require re-energization of the machine before safe removal.

5. Notify affected personnel that the servicing or maintenance is completed and the machine or equipment is ready for use.

PROCEDURE INVOLVING MORE THAN ONE PERSON

In the preceding steps, if more than one individual is required to lock out the equipment, **each shall place his own personal lock on the energy isolating devices.**

SECTION 3 SAWMILL ASSEMBLY

3.1 Unpacking

1. Cut open the plastic shipping shroud; remove and discard.

NOTICE Wear safety goggles; some shipping straps are under pressure and may spring out when cut.

2. Cut the shipping straps holding the bed sections to the pallet.
3. Remove the push handle and plate holding the sawhead in place; retain the hardware and discard the shipping plate.
4. Replace the push handle with the retained hardware at the upper location.
5. Remove the head-locking bolt from the right-side mast and discard.

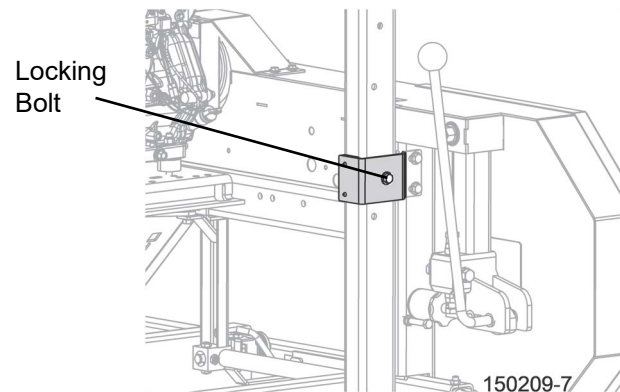
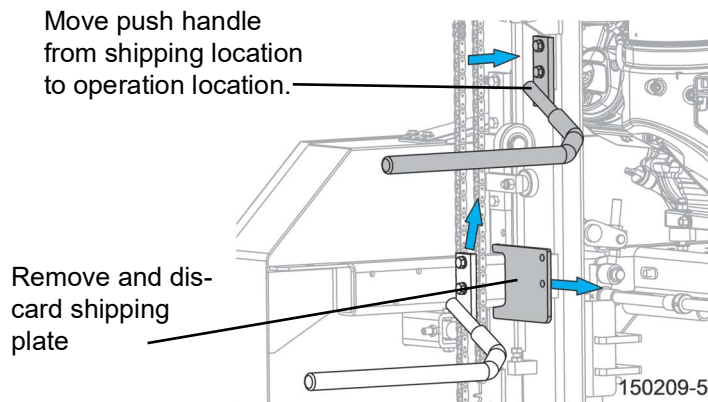

FIG. 3-1

6. Remove the hardware/blade boxes from the crate for later installation.
7. Remove the carriage hold down clamps..
8. Remove the **bolt** for the hold-down bracket for the right side of the mast; do not remove the bracket at this time.

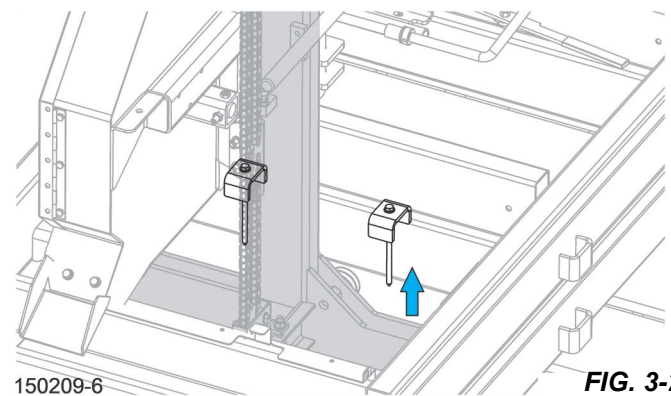

FIG. 3-2

9. Remove the rail wiper and log clamp from the shipping locations on the ends of the bed sections.



WARNING! Use proper lifting equipment rated for lifting over 800 lbs (forklift, hoist, crane) to lift the mill mast and saw head. Failure to follow this may result in serious injury or death.

NOTICE Ensure the mast and head assembly is balanced while lifting. If not set it down and reposition the lift straps.

10. Attach lifting straps to the mast cross beam and lift the mast and head of the mill from the crate; set them aside until the bed is ready.
11. Remove the shipping straps from the bed sections.

NOTE: The top bed will shift when the shipping straps are removed.

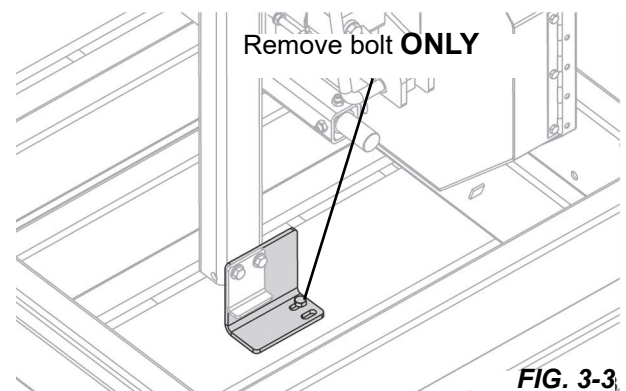

FIG. 3-3

NOTE: Bed sections weight approximately 160 lbs. Use at least two people to move them.

12. Set the bed sections on a level surface.

3.2 Leg Assembly

1. Place a hex nut on each leg approximately half way down the shaft.
2. Slide the outrigger (nut keeper) plate into the mounting bracket.
3. Position the square nut between the plate and the bracket.
4. Thread each leg through the bracket, the square nut, and the plate. (See FIG. 3-2.)
5. Tighten the hex nut around the leg bracket (requires 1 5/16" wrench).
6. Assemble four legs to each bed section.
7. Install all the legs; adjust the nuts as necessary to level the bed.
8. Use a 1 1/4" wrench to turn the hex nut and adjust each leg until the top of the leg is approximately 1" (25mm) below the bed tube.

The bed weight should rest evenly on all legs

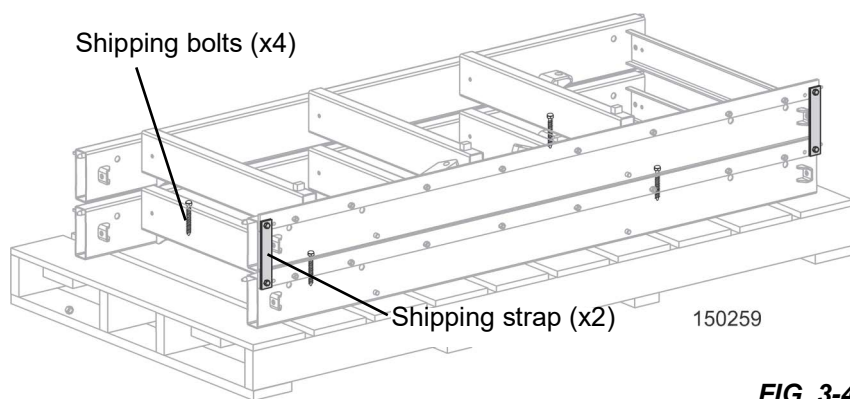

FIG. 3-4

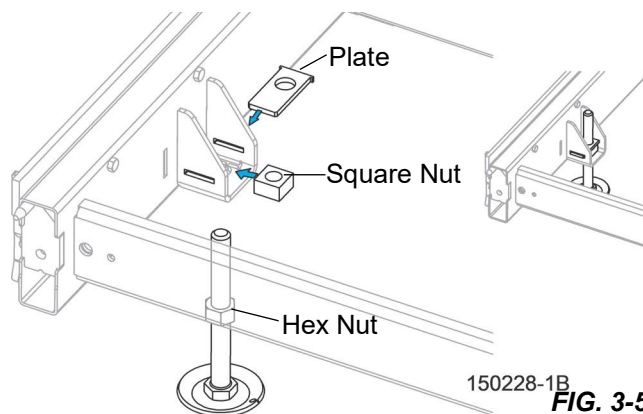

FIG. 3-5

3.3 Bed Section Assembly

1. Lay the bed sections end-to-end so the rail portion of each section is on the same side.
2. Slide the sections together and secure with four (each side, inside and outside) 1/2-13 x 5" hex head bolts and nylon lock nuts.

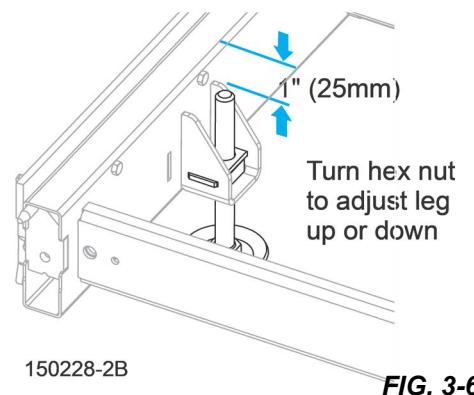

FIG. 3-6

NOTICE Make sure the top surfaces of the outer side of the bed sections are aligned. It may be necessary to adjust one bed section up or down until the surfaces are aligned, then tighten the bolts.

If the rails do not meet flush at the joint, loosen the 8 rail bolts, adjust the rail as needed.

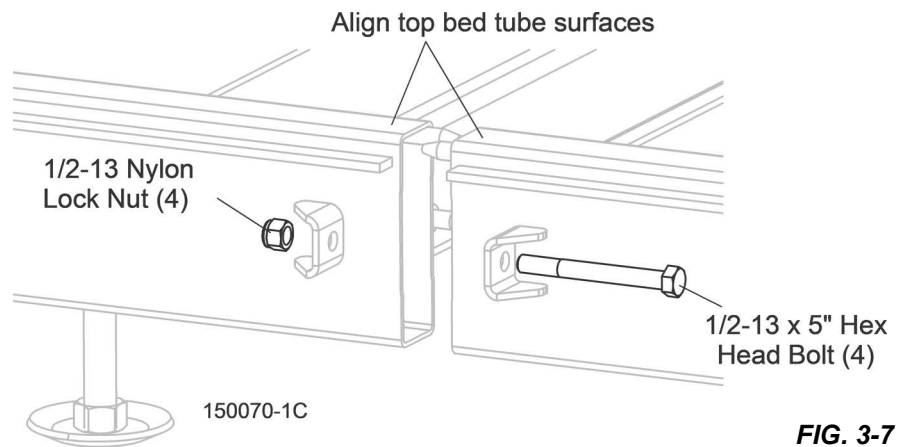

FIG. 3-7

3. Insert the splice bolts into the holes in the track rail and secure with two 3/8-16 x 1" hex head bolts. (If rail bolts were loosened, retighten them at this time.)

NOTE: The threaded holes at the end of the splice are provided to help remove the splice if you wish to disassemble the sawmill. Remove the two splice bolts from the middle holes and thread into the end holes. Evenly turn the bolts clockwise to push the splice pins out of the track rail holes.

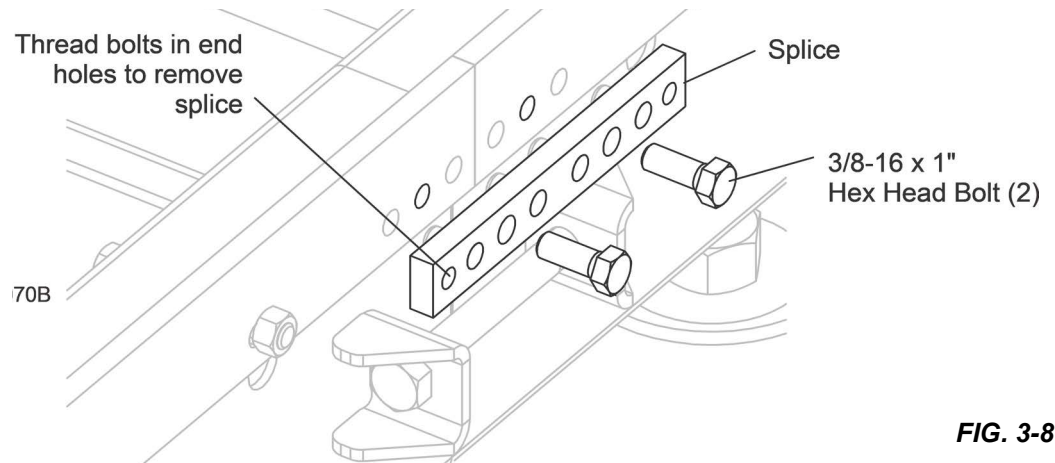
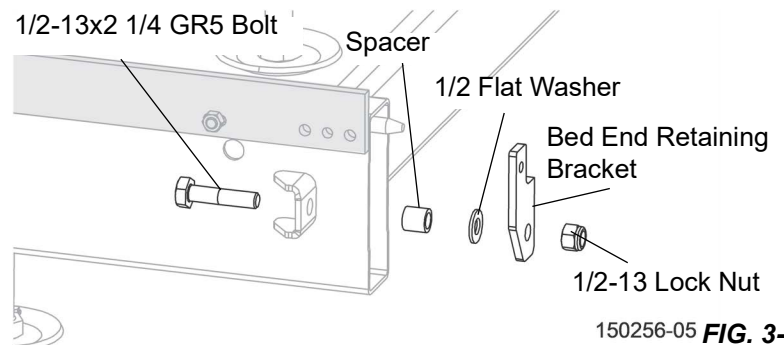

FIG. 3-8

4. Install the bed end retaining brackets to **BOTH ENDS** of the bed frame, on the same side as the roller carriage.



WARNING! Do not operate the sawmill without the bed end retaining brackets properly installed; the saw head may fall from the log bed. Failure to follow this may result in serious injury or death.



150256-05 FIG. 3-9

3.4 Clamp Assembly

Assemble the log clamp to the bed as shown in Figure 3-10. Assemble it in any section that does **not** contain a log support.

3.5 Saw Carriage Assembly

The saw carriage is equipped with two lock pins at the bottom of the mast near the track rollers. These pins can be adjusted to two different positions:

Operation position. This position allows the pins to catch the bottom of the track rail, preventing the saw head from tilting and disengaging the bed frame.

Lock position. To secure the saw head to the bed frame during non-use, rotate the pin at the end of the sawmill so it is clear of the pin bracket. Ensure the pin engages in one of the holes in the bed frame tube. The second pin should remain in the operation position.

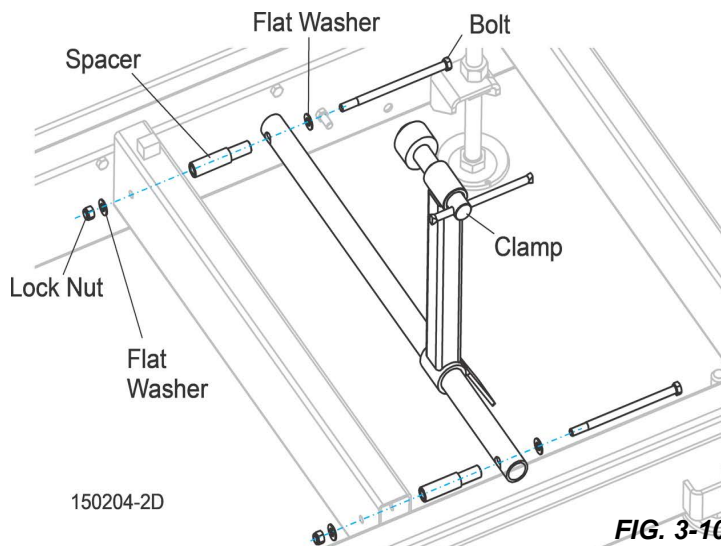

FIG. 3-10

For installation, the locking pins must be pulled out in order to clear the rail. To reposition pin, pull pin outward, rotate, and release into proper position.

1. Position the saw head carriage at the end of the bed frame assembly.
2. Slide the saw head carriage rollers onto the bed frame track, keeping the carriage square to the bed to avoid binding the track rollers.

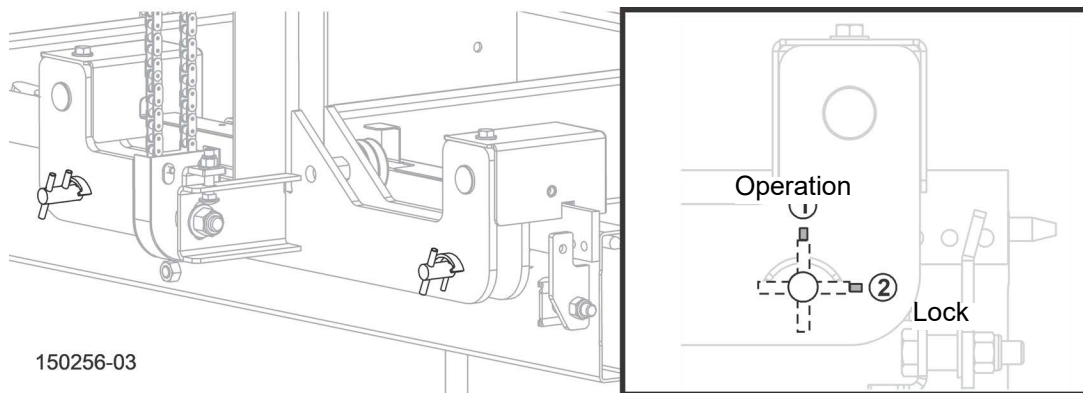

FIG. 3-11

3. Place both carriage lock pins in the operation position, and glide the mast along the rail to ensure it is properly seated. Reposition as necessary to ensure a smooth movement along the rail.
4. On the opposite mast, unbolt the shipping bracket and retaining bracket; discard the shipping bracket.
5. Reattach the retaining bracket as shown in Figure 3-12.

WARNING! Do not operate the sawmill without the retaining bracket properly installed; the saw head may tip and fall from the log bed.

6. On the middle track cover, soak the felt wiper with Dexron III transmission fluid, 10W30 motor oil, or 3-in-1 turbine oil.
7. Attach the middle track cover using the bolts and washers located on the inside faces of the roller housings.
8. Position the middle track cover between the two track roller housings so the opening in the cover is positioned over the roller as shown in Figure 3-12.
9. Install the remaining hardware (track scrapers and wipers) as shown in Figure 3-12.

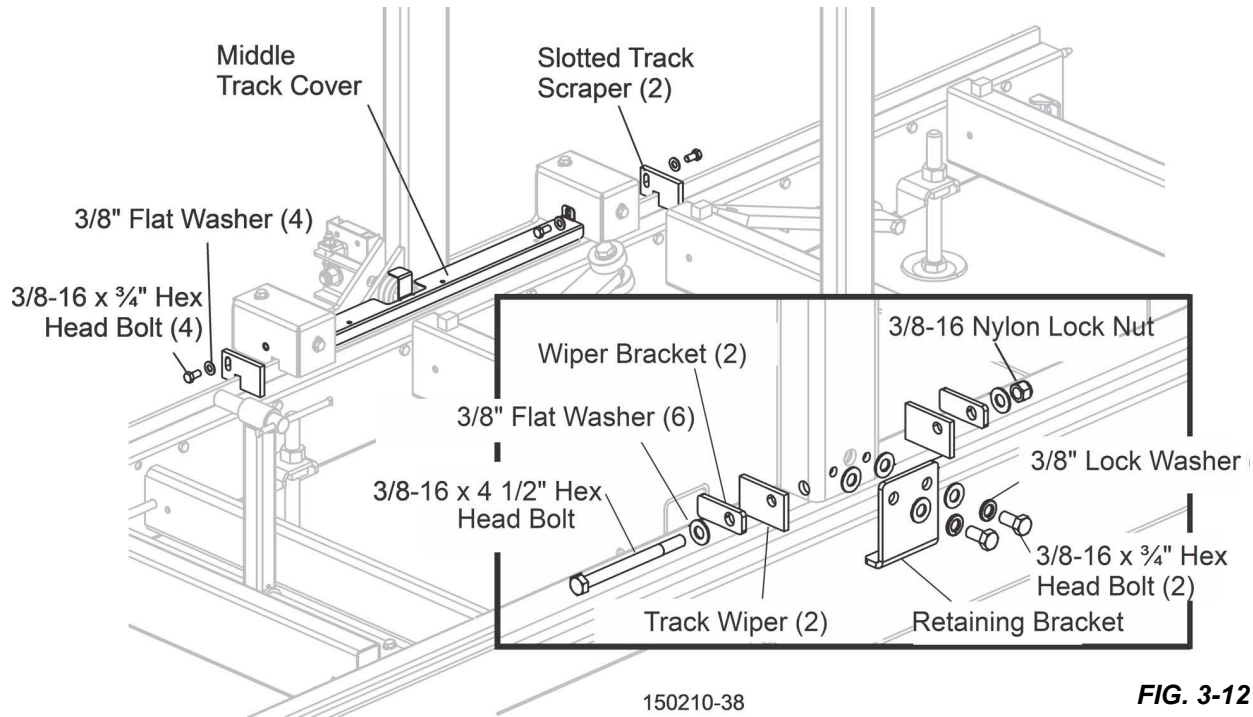

FIG. 3-12

WARNING! Do not operate the sawmill without the retaining bracket properly installed. The saw head may tip and fall from the sawmill resulting in possible injury or damage to the machine.

3.6 Miscellaneous

Disassemble the sawdust deflector from its shipping position and reinstall it for operation.

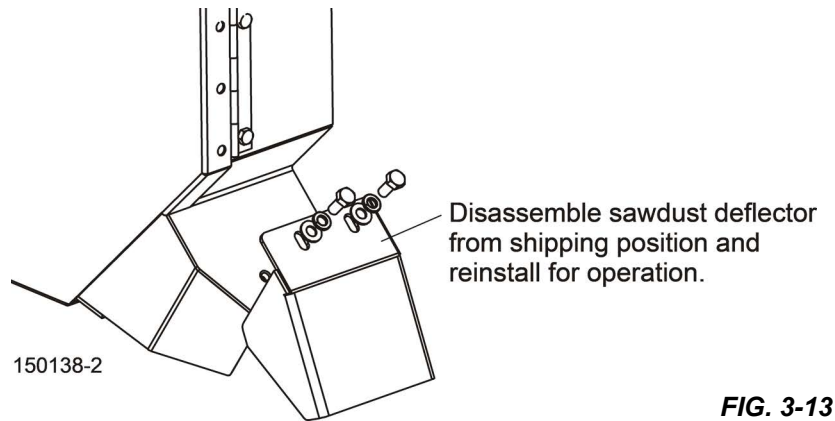

FIG. 3-13

Route the water lube hose on to the spout of the water container.

Install the blade. [See Section "4.3" Installing a Blade.](#) for full details.

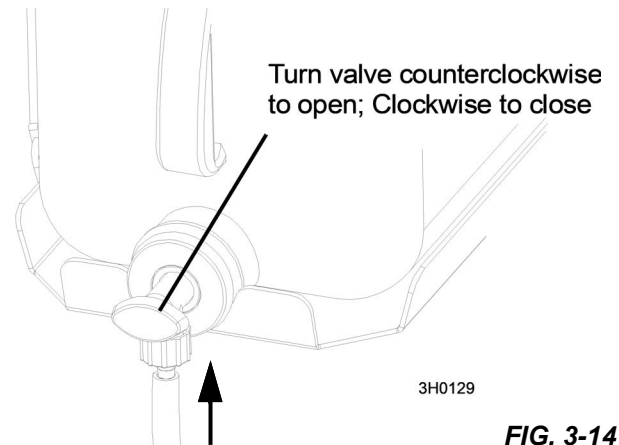

FIG. 3-14

SECTION 4 SAWMILL SETUP

4.1 Sawmill Setup

NOTE: The following setup procedure should be performed whenever the sawmill is moved or reassembled. If sawing problems occur and misalignment is suspected, [See SECTION 5](#) for complete alignment instructions.

LEVELING THE LOG BED

1. Adjust the frame legs so the sawmill appears level. If sawmill is on soft ground, use shims under the legs if necessary.
2. Run a string from the front bed rail to the rear bed rail near the operator's side of the frame.
3. Place **identical spacers** between the string and the front and rear bed rails.
4. Measure the distance between the string and the other bed rails.

Adjust the frame legs until all bed rails measure the same distance from the string. See FIG. 4-1.

5. Repeat the bed rail adjustment with the string at the other side of the sawmill frame.
6. Install a blade ([See Section 4.3](#) through 4.5 Tracking The Blade) and move the saw carriage until the blade is positioned over the front bed rail.

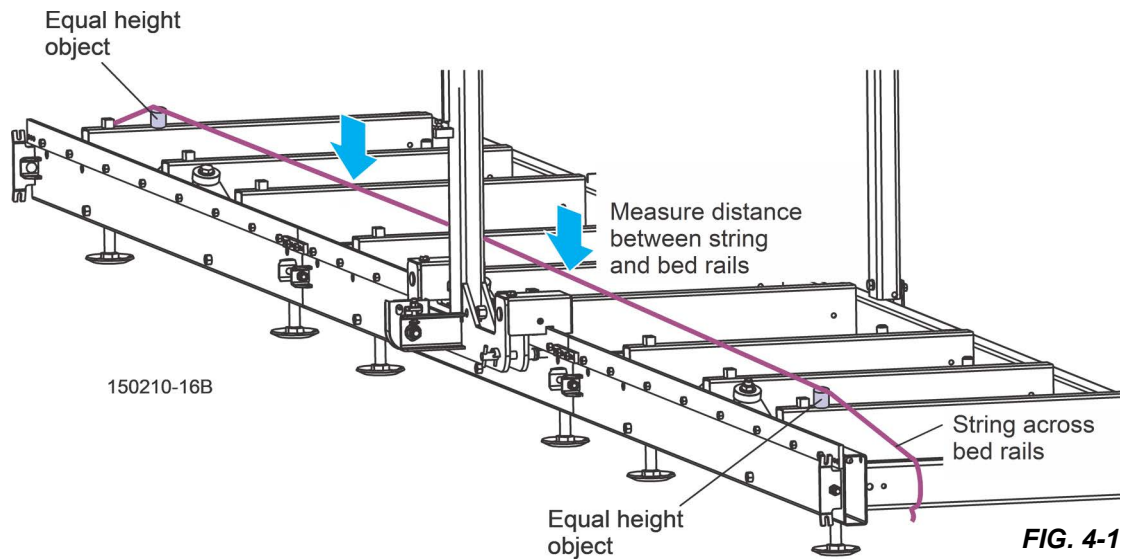

FIG. 4-1

7. Measure the distance from the bed rail to the bottom of the blade near the inside blade guide.
8. Measure the distance from the bed rail to the bottom of the blade near the outside blade guide.

When the blade is parallel to the bed, it will measure the same distance from the bed rail at the inside and outside of the saw head.

LEVELING THE SAWHEAD

1. Turn the saw head tilt adjustment nut clockwise to raise the outside of the saw head.
2. Turn the nut counterclockwise to lower the outside of the saw head.
3. After the saw head is adjusted parallel to the bed rail, check the space between the uppermost mast bearing and mast rail. Adjust as necessary so the space is 1/32" - 1/16" (0.8 - 1.6mm). See FIG. 4-2.

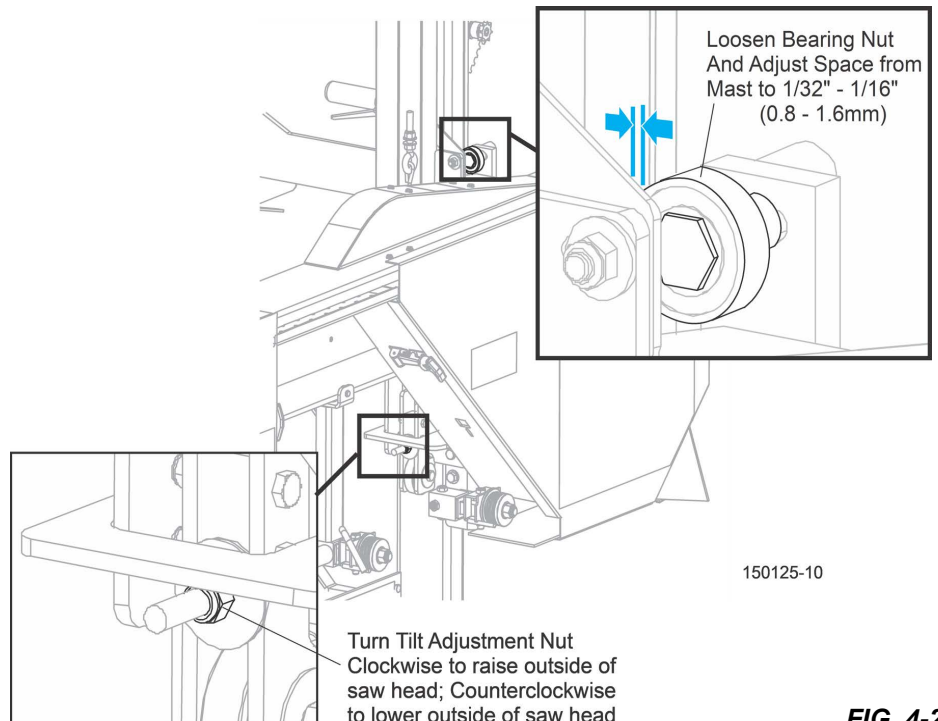

FIG. 4-2

4. Carriage Side Adjustment

The carriage rests on two roller bearings on the rail edge. Two bearings on either side of the roller bearing can be adjusted to keep the carriage tight against the rail. See FIG. 4-3.

NOTE: Do not overtighten! Roller bearings should turn freely.

4.2 Carriage Locking Pins

Prior to mill operation, make sure both lock pins on both sides are in the operation position (lock pins seated in lower notches of pin rest brackets).

Pull the pin outward, rotating as desired, and releasing into proper position. See FIG. 4-4.

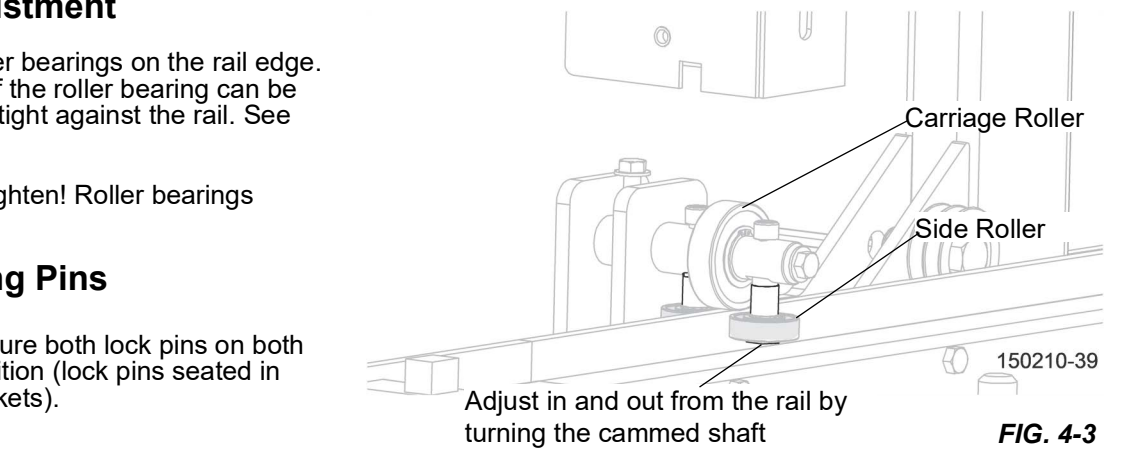

FIG. 4-3

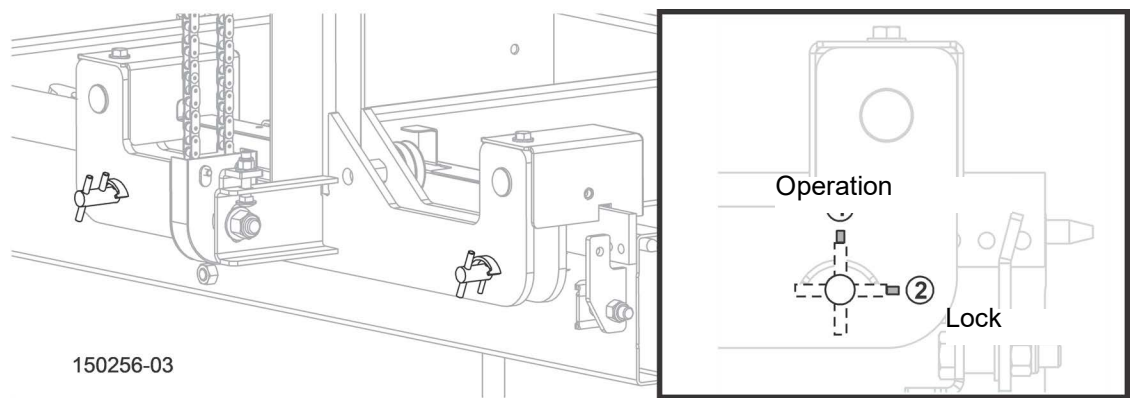

FIG. 4-4

4.3 Installing a Blade

! DANGER! COILED BLADES ARE UNDER SPRING TENSION. KNOW PROPER BLADE HANDLING BEFORE UNPACKING YOUR BLADE. FAILURE TO FOLLOW THIS WILL RESULT IN SERIOUS INJURY.



HOW TO COIL,
UNCOIL, AND
INVERT A BLADE

READ THE PAMPHLET THAT CAME WITH YOUR MILL OR WATCH THE VIDEO ON SAWMILL BLADES BEFORE REMOVING THE BLADE FROM THE BOX.

! DANGER! Always disengage the blade and shut off the sawmill engine before changing the blade. Failure to follow this will result in serious injury or death.

! WARNING! Always wear gloves and eye protection when handling bandsaw blades.

! Changing blades is safest when done by one person!

Keep all other persons away from area when coiling, carrying or changing a blade.

1. Open both blade housing covers.
2. Turn the blade tension handle until the wheel is pulled in and the blade is loose in the blade housing.
3. Lift the blade out of the blade housing.

4. Install the new blade.

When installing a blade, make sure the teeth are pointing the correct direction. The teeth should be pointing toward the operator side of the mill when you are looking at the blade below the blade guides.

5. Position 1 1/4" wide blades on the wheels so the gullet is 1/8" (3.0 mm) out from the edge of the wheel.
6. Close the blade housing covers.
7. Use the tension handle to tension the blade correctly.

4.4 Tensioning The Blade

The blade tensioner is factory-set so proper blade tension is achieved when the rubber spring is compressed 3/16" (4.8 mm). An indicator bolt is provided to indicate when the rubber spring has been compressed properly. To tension the blade, turn the blade tension handle up until it locks in place.

-  **WARNING!** Use both hands to operate the blade tensioner handle.
1. Use the scalloped disk to turn the tensioner shaft. See FIG. 4-5.

2. Tension the blade.
3. Recheck the alignment of the rubber spring washer with the indicator bolt head.
4. Check the blade tension occasionally when adjusting the cant control or while cutting.

As the blade and belts heat up and stretch, the blade tension will change.

5. Adjust the tensioner shaft as necessary to maintain proper blade tension

4.5 Tracking The Blade

1. Make sure the blade housing covers are closed and all persons are clear of the open side of the saw head.
2. Start the engine.
3. Engage the blade, rotating the blade until the blade positions itself on the wheels.

-  **WARNING!** Do not spin the blade wheels by hand.
4. Disengage the blade.

5. Turn off the engine, remove the key, and check the position of the blade on the blade wheels.

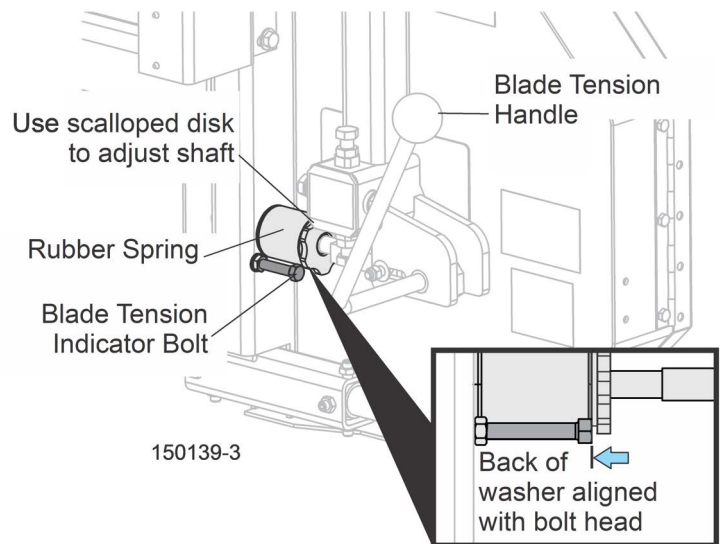

FIG. 4-5

Position 1 1/4" wide blades so the gullet is 1/8" (3.0 mm) out from the edge of the blade wheel ($\pm 1/32$ [.75 mm]). See FIG. 4-6.

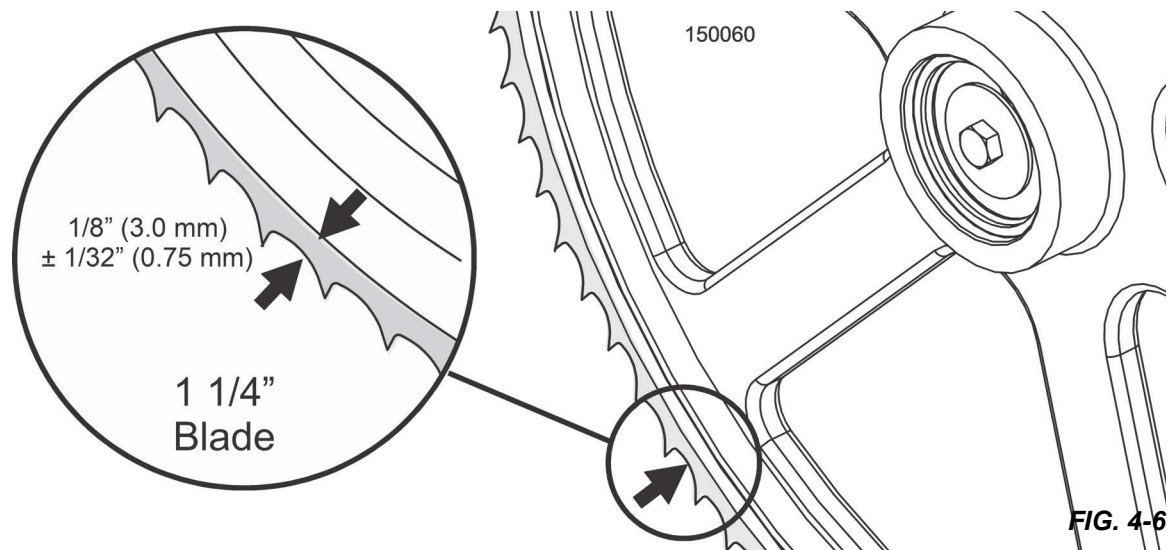

FIG. 4-6

- Use the cant control to adjust where the blade travels on the blade wheels. See FIG. 4-7.

NOTE: If the blade is too far out, back the blade onto the wheel by turning the cant control counterclockwise. If the blade is too far in, turn the cant control clockwise until the gullet of the blade is the correct distance from the front edge of the wheel.

- Adjust the blade tension if necessary to compensate for any changes that may have occurred while adjusting the cant control.
- Close the blade housing covers.

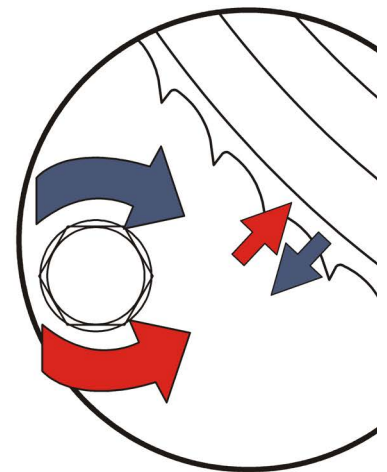
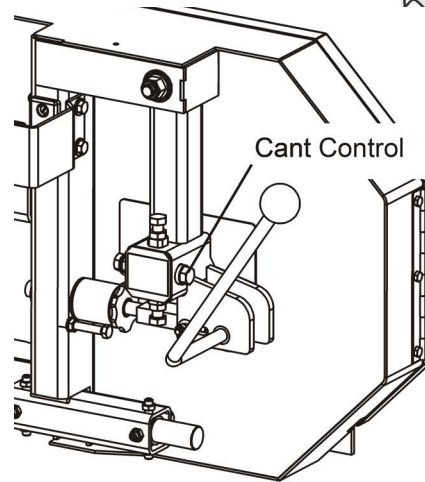

FIG. 4-7

! DANGER! Make sure **all** guards and covers are in place and secured before operating the sawmill.

NOTICE After aligning the blade on the wheels, always double-check the blade guide spacing and location. ([See SECTION 5](#) for more information.)

4.6 Alignment

Mills are aligned at the factory, however, shipping may cause factory alignments of various assemblies to shift. If you have problems during early operation, check the alignment procedures in [SECTION 5 Sawmill Alignment](#).

4.7 Starting The Engine

! DANGER! Make sure **all** guards and covers are in place and secured before operating the sawmill.

The blade must be disengaged and all persons are out of the path of the blade before starting the engine or motor.

! WARNING! Always wear eye, ear, respiration, and foot protection when operating the sawmill.

! See the appropriate manual supplied with your specific engine/motor configuration for starting and operating instructions.

SECTION 5 SAWMILL ALIGNMENT

Two alignment procedures are available to realign the sawmill. The Routine Alignment instructions should be performed as necessary to solve sawing problems not related to blade performance. The Complete Alignment procedure should be performed approximately every 1500 hours of operation (sooner if you regularly transport the sawmill over rough terrain).

NOTE: The procedures listed here must be performed in the order they appear.

5.1 Routine Alignment Procedure

Level the frame and adjust the saw head as described in Section 3.

Blade Installation

1. Remove the blade and check the blade wheel belts. Remove any sawdust buildup from the surface of the belts. Replace worn belts if they do not keep the blade from contacting the blade wheel.
2. Install a clean blade and apply the appropriate tension ([See Section 4.4](#)).
3. Adjust the idle-side cant control to track the blade ([See Section 4.5](#)).
4. Close the blade housing cover and make sure all persons are clear of the saw head.
5. Start the engine.
6. Engage the blade, rotating the blade until the blade positions itself on the wheels.

 **WARNING!** Do not spin the blade wheels by hand. Spinning the blade wheels by hand may result in serious injury.

7. Disengage the blade. Turn the engine off.

Saw Head Tilt

As the blade enters a wide log or cant, the outside of the saw head will drop down slightly. To compensate for the drop, the saw head is adjusted 1/16" (1.5 mm) higher at the outside.

1. Move the saw carriage so the blade is positioned over a bed rail. Adjust the blade guide arm to 1/2" (15 mm) from full open.
2. Raise the saw head so the bottom of the blade measures 14 3/4" (375 mm) from the top surface of the bed rail near the inner blade guide assembly.
3. Measure from the blade to the bed rail near the outer blade guide assembly. This measurement should be 1/16" (1.5 mm) higher than the inner measurement or 14 13/16" (376.5 mm).
4. Turn the saw head tilt adjustment nut clockwise to raise the outside of the sawhead.
5. Turn the nut counterclockwise to lower the outside of the saw head.
6. After the saw head is adjusted parallel to the bed rail, check the space between the uppermost mast bearing and mast rail.

- Adjust as necessary so the space is 1/32" - 1/16" (0.8 - 1.6mm).

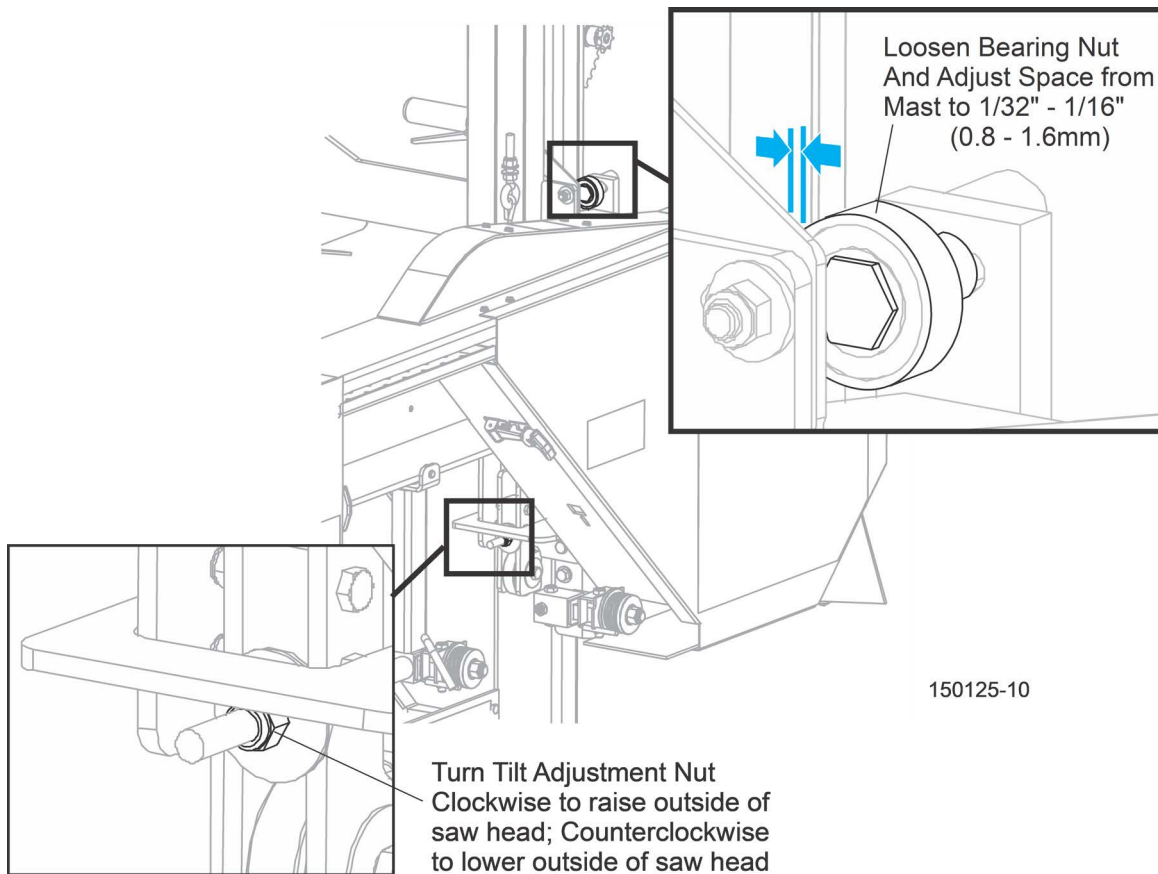

FIG. 5-1

Blade Guide Arm Alignment

The blade guide arm moves the outer blade guide in and out. If the arm becomes loose, the blade guide will not deflect the blade properly, causing inaccurate cuts. A loose blade guide arm can also cause blade vibration.

- Adjust the blade guide arm out to 1/2" (13 mm) from fully open. See FIG. 5-2.
- Use the inside top and bottom screws to adjust the arm up until the slide pad touches the saw head brace tube.
- Tighten the jam nuts.
- Adjust the blade guide arm in all the way toward the other blade guide.
- Use the outside top and bottom screws to adjust the arm up until the slide pad touches the saw head brace tube. Tighten the jam nuts.

NOTE: When adjusting the blade guide arm screws, be careful not to tighten the screws too much or put the

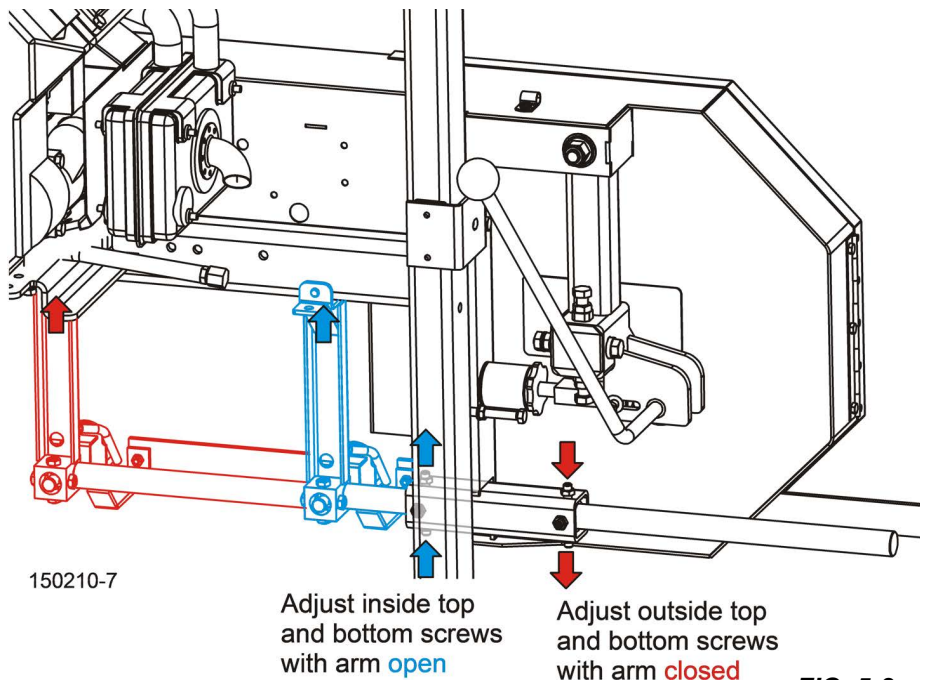

FIG. 5-2

arm in a bind. Operate the blade guide arm to ensure the arm moves easily in and out.

6. With the blade guide arm still all the way in toward the other blade guide, tighten all the side screws until they touch the arm. See FIG. 5-3.
7. Back the screws off 1/4 turn and tighten the jam nuts.

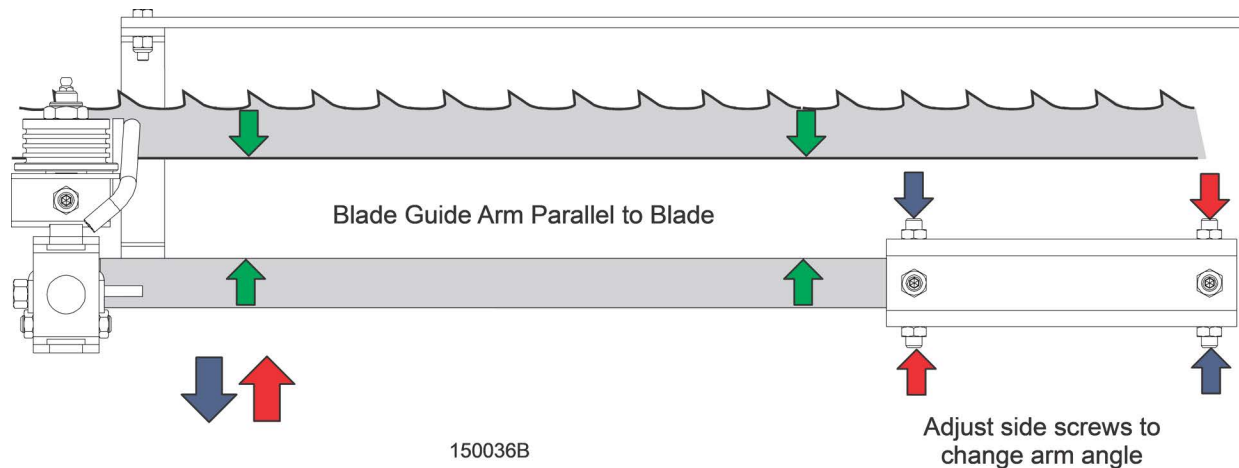

FIG. 5-3

8. Measure the distance between the blade guide arm and back edge of the blade.
9. Adjust the appropriate side screws on the blade guide arm housing so the arm measures the same distance from the blade at both ends of the arm.
10. To move the blade guide end of the arm toward the front of the sawmill, loosen jam nuts on the front inside screw and the rear outside screw.
11. Turn the screws counterclockwise one full turn and tighten the jam nuts.
12. Loosen the jam nuts on the front outside screw and the rear inside screw.
13. Turn the screws clockwise until they touch the arm, back off 1/4" turn, and tighten the jam nuts.
14. To move the blade guide end of the arm toward the rear of the sawmill, loosen jam nuts on the front outside screw and the rear inside screw.
15. Turn the screws counterclockwise one full turn and tighten the jam nuts.
16. Loosen the jam nuts on the front inside screw and the rear outside screw.
17. Turn the screws clockwise until they touch the arm, back off 1/4" turn, and tighten the jam nuts.

Blade Guide Vertical Tilt Alignment

The blade guides should be adjusted properly in the vertical plane. If the blade guides are tilted vertically, the blade will try to travel in the tilted direction.

A Blade Guide Alignment Tool (BGAT) is provided to help you measure the vertical tilt of the blade.

1. Open the adjustable blade guide arm 1/2" (13 mm) from full open.
2. Clip the alignment tool on the blade. See FIG. 5-4.
3. Position the tool close to the outer blade guide assembly.

Be sure the tool does not rest on a tooth or burr, and is lying flat against the bottom of the blade.

4. Move the carriage so that the front end of the tool is positioned above the bed rail. Measure the distance from the bed rail to the bottom edge of the tool.

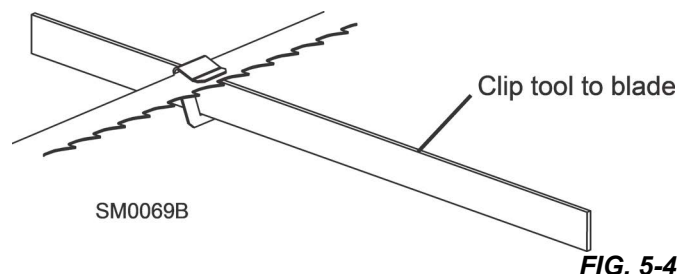

5. Move the carriage so that the back end of the tool is positioned above the bed rail. Measure the distance from the bed rail to the bottom edge of the tool.
6. If the measurement from the tool to the bed rail is not equal within 1/32" (.75 mm), adjust the vertical tilt of the outer blade guide roller.
7. Loosen one set screw at the side of the blade guide assembly. See FIG. 5-5.
8. Loosen the jam nuts on the top and bottom vertical tilt adjustment screws.
 - 1). To tilt the roller up, loosen the bottom screw and tighten top screw. Reverse this to tilt down. Tighten the jam nuts and recheck the tilt of the blade.

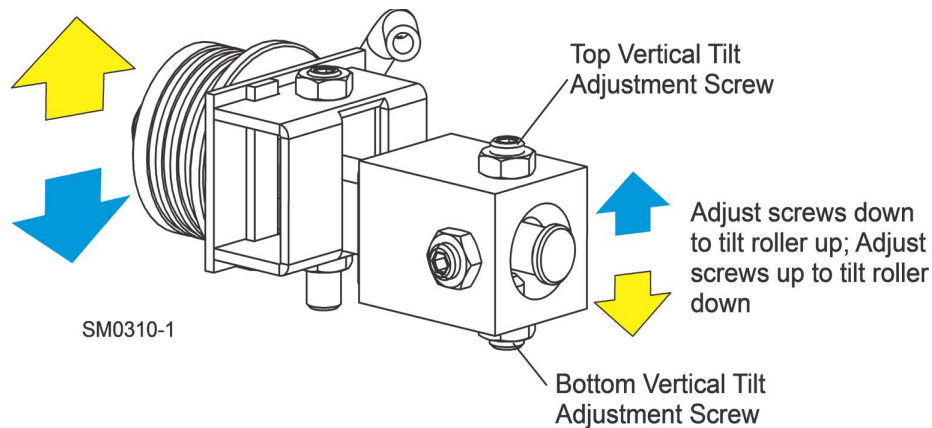

FIG. 5-5

9. Move the blade guide alignment tool close to the inner blade guide roller assembly and repeat the above steps. Adjust the vertical tilt of the inner blade guide if necessary.

Blade Guide Horizontal Tilt Adjustment

If the blade guides are tilted in the wrong direction horizontally, the back of the blade may contact the flange as the roller is spinning down, causing it to push the blade away from the guide roller.

1. Remove the blade guide alignment tool from the blade and adjust the blade guide arm halfway in.
2. Remove the clip from the blade guide alignment tool and place the tool against the face of the outer blade guide roller. See FIG. 5-6.

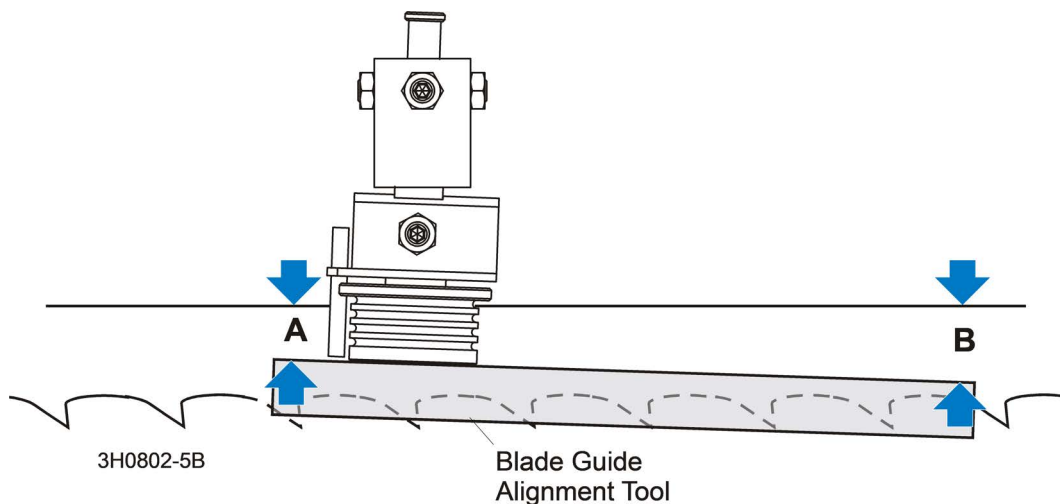

FIG. 5-6

3. Measure between the back edge of the blade and the tool at the end closest to the inner blade guide ("B").

4. Measure between the back edge of the blade and the other end of the tool ("A").

The roller should be tilted slightly to the left ('A' 1/8" [3 mm] less than 'B' ±1/8" [3 mm]).

5. Loosen the jam nuts on the horizontal tilt adjustment screws. See FIG. 5-7.

1). To tilt the roller left, loosen the right screw and tighten left screw. Reverse to tilt right. Tighten the jam nuts and recheck the tilt of the blade.

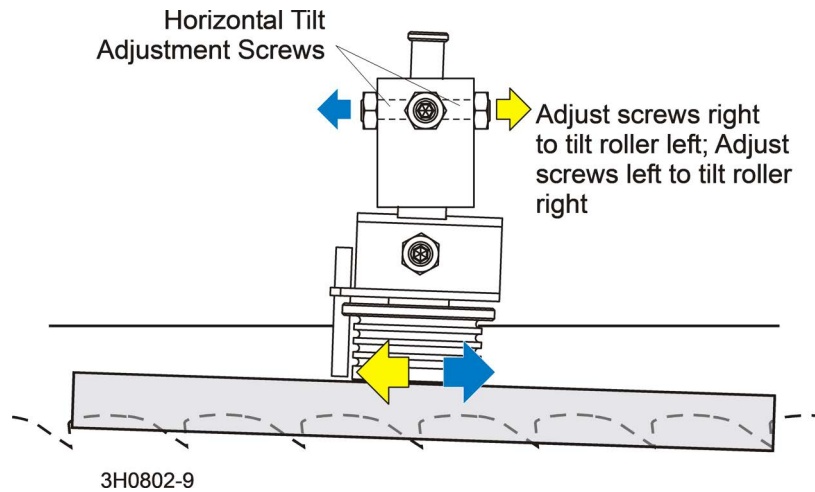

FIG. 5-7

6. Repeat the above steps for the inner blade guide roller assembly.

NOTE: Once the blade guides have been adjusted, any cutting variances are most likely caused by the blade.

Blade Guide Flange Spacing

Each blade guide must be adjusted so the roller flange is the correct distance from the back edge of the blade. If the flange is too close to or too far from the blade, the sawmill will not cut accurately.

HINT: When adjusting blade guide spacing, loosen the top set screw and one side set screw only. This will ensure horizontal and vertical tilt adjustments are maintained when the adjustment screws are retightened.

1. Measure the distance between the flange on the outer blade guide roller to the back edge of the blade. This distance should measure 1/8" (3.0 mm). Adjust the roller back or forward if necessary.

2. Loosen the top and one side screw shown. See FIG. 5-8.

3. Tap the blade guide forward or backward until properly positioned.

4. Retighten the screws and jam nuts.

5. Measure the distance between the flange on the inner blade guide roller to the back edge of the blade.

This distance should measure 1/16" (1.5 mm). Adjust the roller back or forward if necessary.

Side Support Alignment

Logs and boards are clamped against the side supports when sawing. The sides supports must be square to the bed to ensure square lumber.

1. Place a flat board across the bed rails. Swing a side support up so that it is vertical.

2. Pull back at the top of the support to eliminate slack as if a log were being clamped against it.

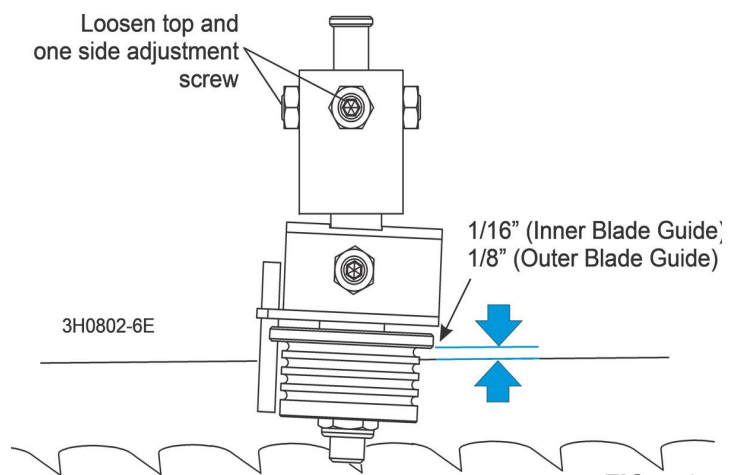

FIG. 5-8

- Place a square against the face of the side support. The side support should be square or slightly tilted forward 1/32" (0.8 mm). Adjust the vertical tilt of the side support if necessary.

Loosen the top adjustment bolt, adjust the side support, and retighten the bolt. Turn the adjustment bolt counterclockwise to tilt the top of the side support forward.

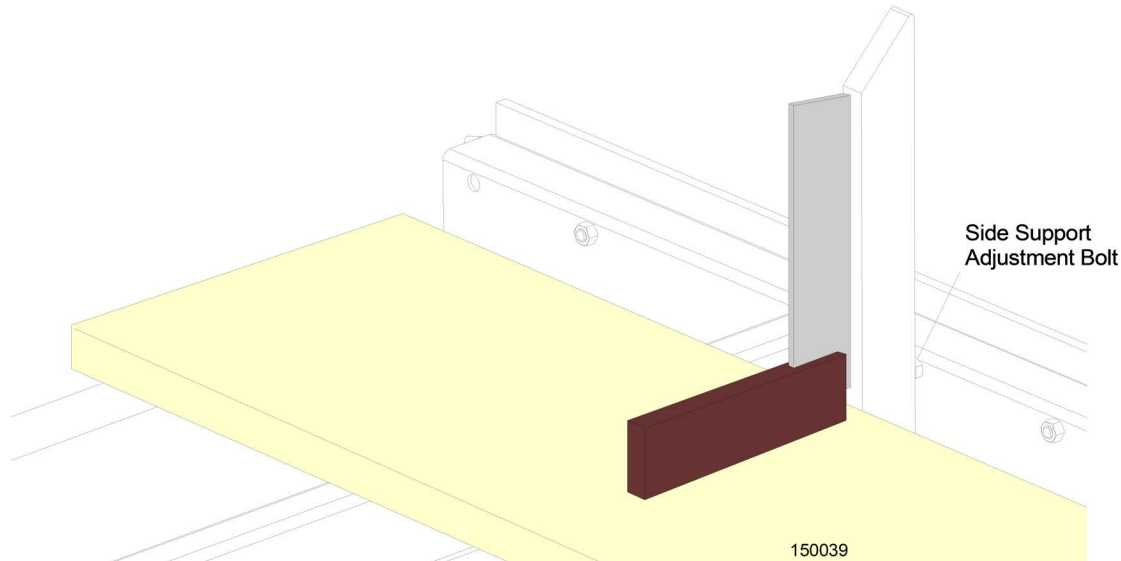

FIG. 5-9

- Repeat the vertical check for the remaining side supports and adjust as necessary.

Blade Height Scale Adjustment

After the entire sawmill has been aligned and all adjustments made, check that the blade height scale indicates the true distance from the blade to the bed rails.

- Move the saw carriage so the blade is positioned directly above one of the bed rails. Measure from the bottom edge on a down-set tooth of the blade to the top of the bed rail, near the inner blade guide assembly.
- View the blade height scale with eyes level with the indicator. The scale should indicate the actual distance from the blade to the bed rail. Adjust the indicator if necessary.

Loosen the indicator bracket mounting nut. Adjust the bracket up or down until the indicator is aligned with the correct mark on the scale (+0 -1/32 [0.8 mm]). Retighten the indicator mounting nut.

For example, if the measurement from the down-set tooth of the blade to the bed rail was 14 3/4" (375 mm), make sure the indicator reads 14 3/4" (375 mm) on the scale.

5.2 Complete Alignment Procedure

NOTE: The procures listed here must be performed in the order they appear

Frame Setup

Before performing the following alignment procedures, setup the mill on firm, level ground.

Level the frame and adjust the saw head as described in Section 4.1 Sawmill Setup.

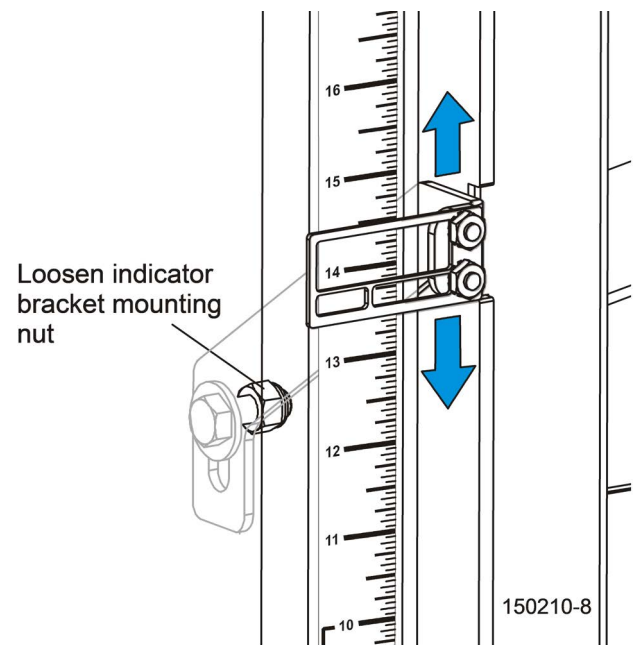



FIG. 5-10

Blade Installation

1. Remove the blade and replace the blade wheel belts. New blade wheel belts are required to perform the complete alignment procedure.
2. Blow sawdust off of the blade guide assemblies. Remove sawdust from the blade housings.
3. Remove the blade guide assemblies.

NOTE: To remove the blade guide assemblies and maintain the tilt adjustments, only loosen one side screw and the top screw. Leaving the other side screw and bottom screw in position will insure you will return the rollers to their original tilt adjustment.

4. Adjust the outer blade guide arm in or out until the outer blade guide is approximately 24" from the inner blade guide.
5. Install a new blade and apply the appropriate tension ([See Section 4.4](#)).
6. Close the blade housing covers and make sure all persons are clear of the saw head.
7. Start the engine.
8. Engage the blade, rotating the blade until the blade positions itself on the wheels.

 **WARNING!** Do not spin the blade wheels by hand. Spinning the blade wheels by hand may result in serious injury.

9. Disengage the blade. Turn the engine off.

Saw Head Tilt [See "Saw Head Tilt" on page 5-1](#)

Blade Wheel Alignment

The blade wheels should be adjusted so they are level in the vertical and horizontal planes. If the blade wheels are tilted up or down, the blade will want to travel in the tilted direction. If the blade wheels are tilted horizontally, the blade will not track properly on the wheels.

Use the blade guide alignment tool to check the vertical alignment of each blade wheel.

1. Attach the tool to the blade near the inner blade guide mount.

Be sure the tool does not rest on a tooth or burr, and is lying flat against the bottom of the blade.

2. Move the saw carriage so the front end of the tool is positioned over the first bed rail.
3. Measure from the bottom of the tool to the top surface of the bed rail.
4. Move the saw carriage so the rear of the tool is positioned over the bed rail.

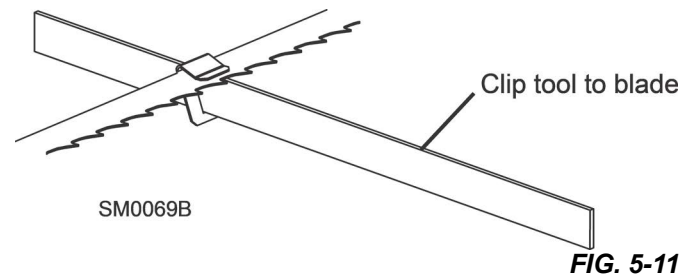

5. Again, measure from the bottom of the tool to the bed rail.
6. If the two measurements differ by more than 1/16" (1.5 mm), adjust the vertical tilt of the drive-side blade wheel.

7. Use the vertical adjustment screws to adjust the drive-side blade wheel. See FIG. 5-12.
 - 1). To tilt the wheel down/up, loosen the top/bottom adjustment screw one quarter turn.
 - 2). Loosen the jam nut on the bottom/top adjustment screw and tighten the screw.
 - 3). Tighten the top and bottom jam nuts.

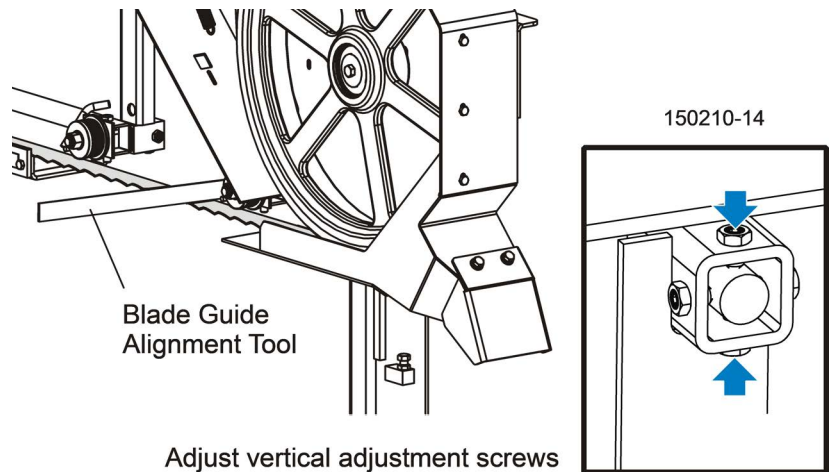

Adjust vertical adjustment screws down to tilt drive-side blade wheel up; Adjust screws up to tilt wheel down

FIG. 5-12

8. Recheck the vertical tilt of the drive-side blade wheel with the blade guide alignment tool.
9. Readjust the blade wheel as necessary until the front and rear of the tool are the same distance from the bed rail (within 1/16" [1.5 mm]).
10. Remove the tool from the blade and reattach it near the outer blade guide assembly.
11. Measure from the tool to the bed rail at both ends of the tool. If the measurements at the front and rear ends of the tool differ by more than 1/16" (1.5 mm), adjust the vertical tilt of the idle-side blade wheel.

12. Use the vertical adjustment screws to adjust the idle-side blade wheel.
 - 1). To tilt the wheel down/up, loosen the top/bottom adjustment screw one quarter turn.
 - 2). Loosen the jam nut on the bottom/top adjustment screw and tighten the screw.
 - 3). Tighten the top and bottom jam nuts.

13. Recheck the vertical tilt of the idle-side blade wheel with the blade guide alignment tool.
14. Readjust the blade wheel as necessary until the front and rear of the tool are the same distance from the bed rail (within 1/16" [1.5 mm]).

15. Check the position of the blade on the idle-side blade wheel.

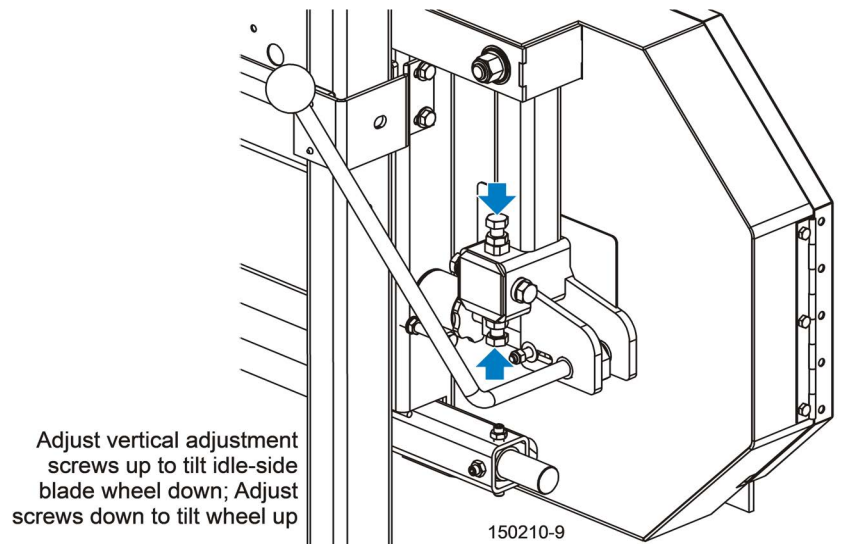

Adjust vertical adjustment screws up to tilt idle-side blade wheel down; Adjust screws down to tilt wheel up

The horizontal tilt of the blade wheel should be adjusted so that the gullet of an 1-1/4" blade is 1/8" (3 mm) out from the front edge of the wheel ($\pm 1/32$ [0.75 mm]).

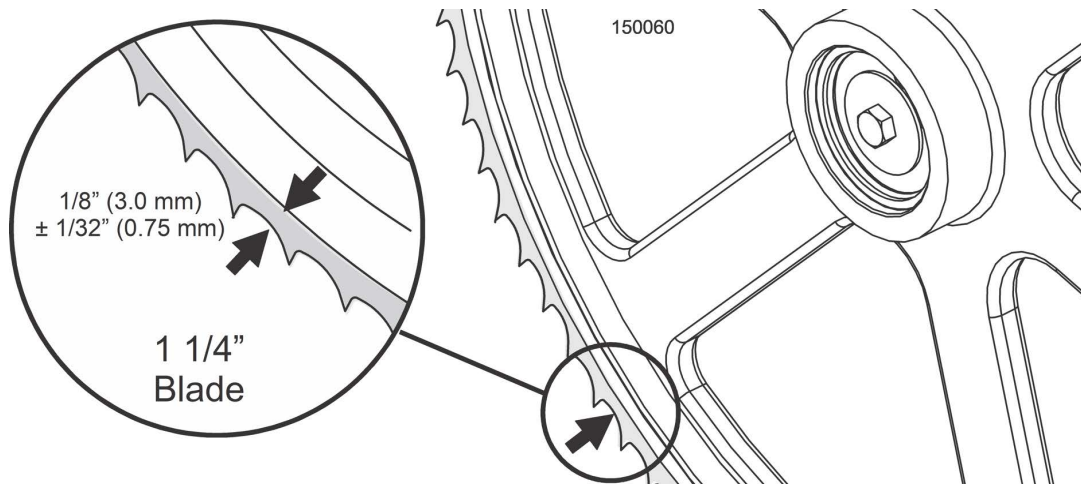

FIG. 5-13

16. Use the cant control adjustment to adjust the idle-side blade wheel.

17. If the blade is too far forward on the wheel, turn the cant control counterclockwise. Reverse if it is too far back on the wheel.

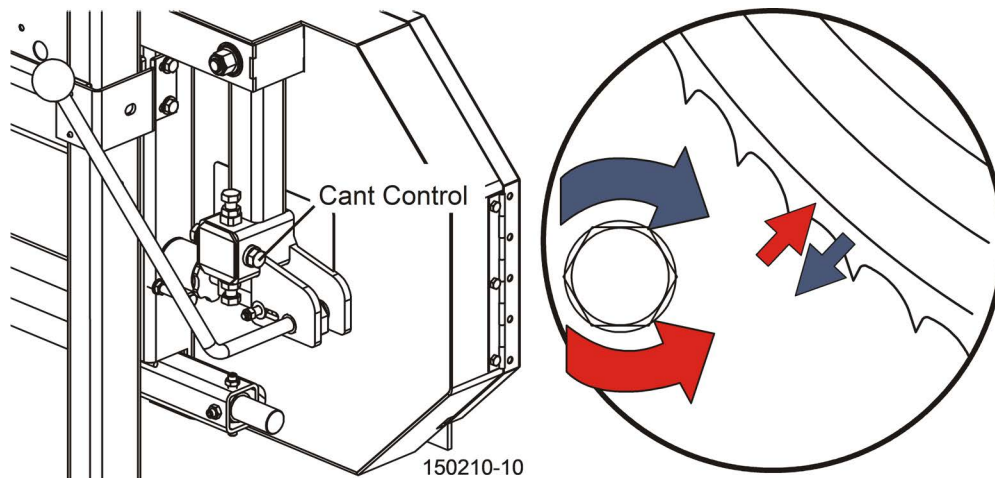

FIG. 5-14

18. Check the position of the blade on the drive-side blade wheel.

The blade should be positioned on the wheel as described for the idle-side blade wheel.

19. Adjust the drive-side blade wheel if necessary.

20. Use the horizontal adjustment screws to adjust the drive-side blade wheel.

1). To move the blade back/forward on the wheel, loosen the right/left adjustment screw one quarter turn.

2). Loosen the jam nut on the left/right adjustment screw and tighten the screw.

3). Tighten the left and right jam nuts.

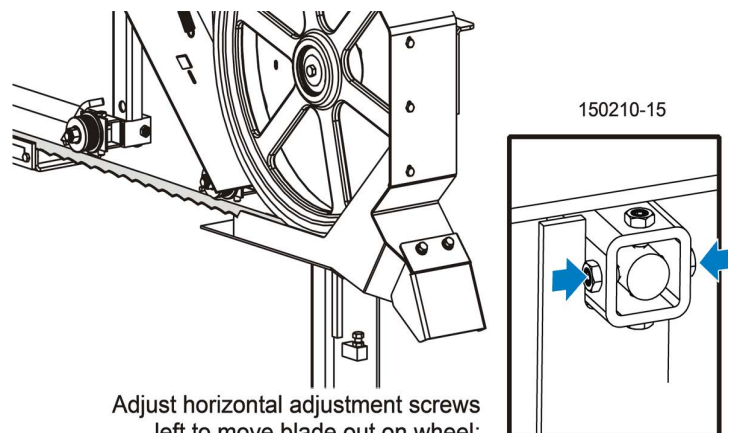

Adjust horizontal adjustment screws left to move blade out on wheel; Adjust screws right to move blade in on wheel

FIG. 5-15

Blade Guide Installation

Each Wood-Mizer sawmill has two blade guide assemblies that help the blade maintain a straight cut. The two blade guide assemblies are positioned on the saw head to guide the blade on each side of the material being cut.

One blade guide assembly is mounted in a stationary position on the drive side of the saw head. This assembly is referred to as the "inner" blade guide assembly.

The other blade guide assembly is mounted on the idle side of the saw head. It is referred to as the "outer" assembly and is adjustable for various widths of materials to be processed.

NOTE: Before installing the blade guide assemblies, remove the blade guide adjusting screws and apply a lubricating oil such as 10W30 or Dexron III to each screw. This will prevent the screws and threaded holes from corroding and make screw adjustments easier.

1. Install the outer blade guide assembly (with waterlube tube) to the mounting block on the blade guide arm. Position the assembly so the roller flange is 1/8" (3.0 mm) from the blade.
2. Install the inner blade guide assembly to the mounting block on the saw head. Position the assembly so the roller flange is 1/16" (1.5 mm) from the blade.
3. Tighten the two previously-loosened tilt adjustment screws to secure the blade guide assembly.
4. Loosen the top vertical adjustment jam nut and tighten the bottom vertical adjustment jam nut to adjust the blade guide roller up so it does not touch the blade.

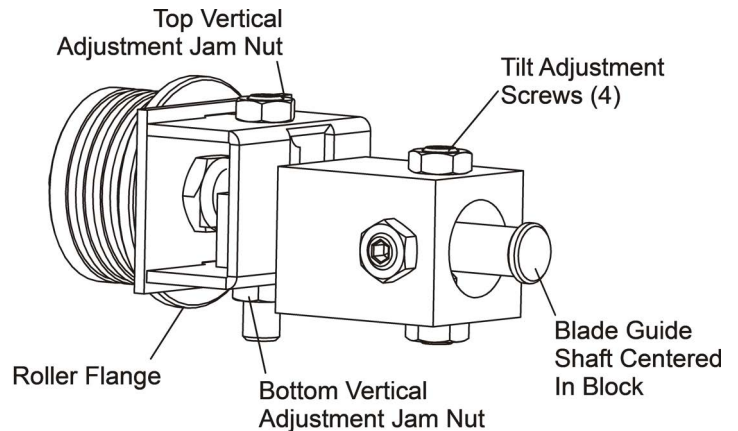

3H0802-15

FIG. 5-16

Blade Guide Arm Alignment [See "Blade Guide Arm Alignment" on page 5-2](#)

Blade Guide Deflection

Perform the following steps to achieve proper blade deflection with the blade guides.

1. Raise the saw head until the blade is 15" (375 mm) above a bed rail. Measure the actual distance with a tape from the top of the rail to the bottom of the blade.
2. Make sure the two vertical adjustment set screws are threaded into the blade guide shaft until they touch each other.

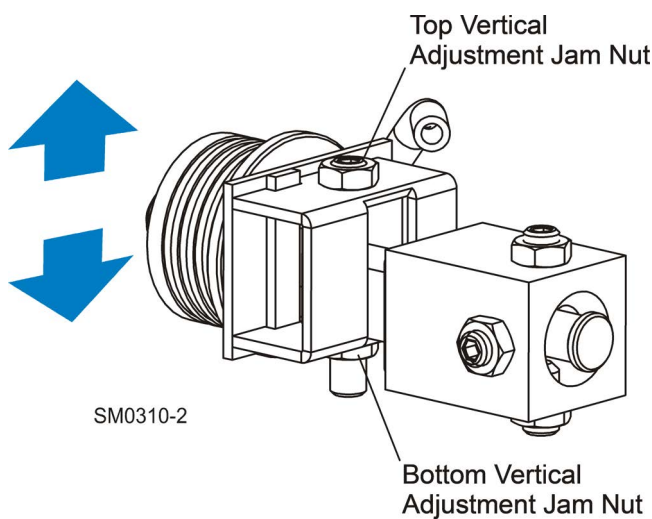

SM0310-2

3. Loosen the bottom jam nut and tighten the top jam nut until the blade guide deflects the blade down until the bottom of the blade measures 14 3/4" (370 mm) from the bed rail.

4. Repeat for the other blade guide.

NOTE: Be sure that the blade guide deflector rod clears the blade on both guide assemblies. The rod on the outer guide assembly should be checked with the arm all the way in and all the way out.

NOTICE For the remainder of the **Complete Alignment**, refer back to **Blade Guide Vertical Tilt Alignment** [See "Blade Guide Vertical Tilt Alignment" on page 5-3](#) and continue on until the end of the **Routine Alignment**.

FIG. 5-17

SECTION 6 SAWMILL OPERATION

6.1 Loading, Turning And Clamping Logs

TO LOAD LOGS

1. Start the engine and move the saw carriage to the front end of the frame.

CAUTION! Before loading a log, be sure the cutting head is moved far enough forward so the log does not hit it. Failure to follow this may result in machine damage.

2. Adjust the log clamps all the way down and move them toward the loading side of the sawmill frame.

NOTE: The clamps can be lifted and removed from the bracket assemblies to avoid damage to the clamp when loading a log.

CAUTION! Be sure the log clamps are adjusted out of the path of the log before loading a log onto the bed. Failure to follow this may result in machine damage.

3. Raise the side supports on the sawmill bed to prevent the log from falling off the side of the bed.

Place the **optional** loading ramps* (part number 015804) in the frame brackets that will evenly support the length of the log. See FIG. 5-1.

4. Position the log at the foot of the ramps.

5. Use a cant hook** (part number CH48) to roll the log up the ramps and onto the sawmill bed. Position the log against the side supports.

NOTE: Position the log on the bed sections to maximize support of the log by the bed. If the log overhangs the bed, (particularly if the optional bed extension is installed) it may tend to sag, resulting in inaccurately sawn lumber.

6. Remove the **optional** log ramps and set aside.

CAUTION! The saw head will hit the spring-loaded ramp stops when adjusted for low cuts. Remove the loading ramps before sawing to prevent damage to the saw head and/or blade guide arm.

If you did not purchase the optional loading ramps, use boards for ramps or use log loading equipment to load the log on the sawmill bed.

NOTE: Logs also may be loaded onto the mill with a tractor or other equipment specifically designed for that purpose.

TO TURN LOGS

1. Use cant hooks to rotate the log on the sawmill bed.
2. Spin the log against the side supports until it is turned the way you want it for the first cut.

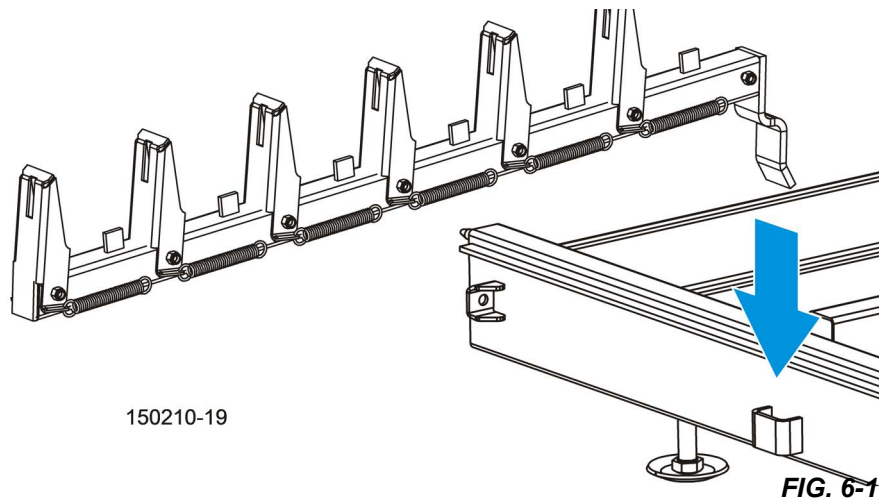

*.Also available as part of the LT15OP, Optional Package Kit for the LT15.

**Also available as part of the LT15OP, Optional Package Kit for the LT15.

TO CLAMP LOGS

1. Slide the clamp against the log and turn the locking handle to lock the clamp against the log. See FIG. 6-2.

CAUTION! Make sure the side supports and clamp are positioned low enough for the blade to pass over them. If they are not, back the clamp off slightly and push the side supports down until they are positioned below the level of your first few cuts.

TO LEVEL A TAPERED LOG

Use shims or the **optional** Log Wedge* (part number 015809) to raise either end of a tapered log, if desired.

Shim one end of the log until the heart of the log measures the same distance from the bed rails at each end of the log.

6.2 Up/Down Operation

1. Install a blade, if needed, and check for correct blade tension. (See 4.3).
2. Set the cutting head to the desired height. (The blade height scale shows the height of the blade above the bed rails.)
3. Use the up/down crank to raise or lower the cutting head.
4. Press the handle lock and turn the crank clockwise to lower the saw head or counterclockwise to raise the saw head.

Each notch in the crank wheel will move the blade 1/16" (1.6mm). A complete revolution of the wheel is 1" (25mm).

5. Release the handle lock to lock the saw head in place.

Use the pointer and the round up/down blade height scale for quick reference when cutting. See FIG. 6-4.

CAUTION! DO NOT try to force the carriage above the 27" (68 cm) mark or below the 1" (2.54 cm) mark. Damage to the up/down system may result.

6.3 Blade Guide Arm Operation

1. Estimate the maximum width of the log.

The outer blade guide should be adjusted to clear the widest section of the log by less than 1" (25.4 mm).

2. Use the blade guide arm lever to adjust the outer blade guide as necessary.

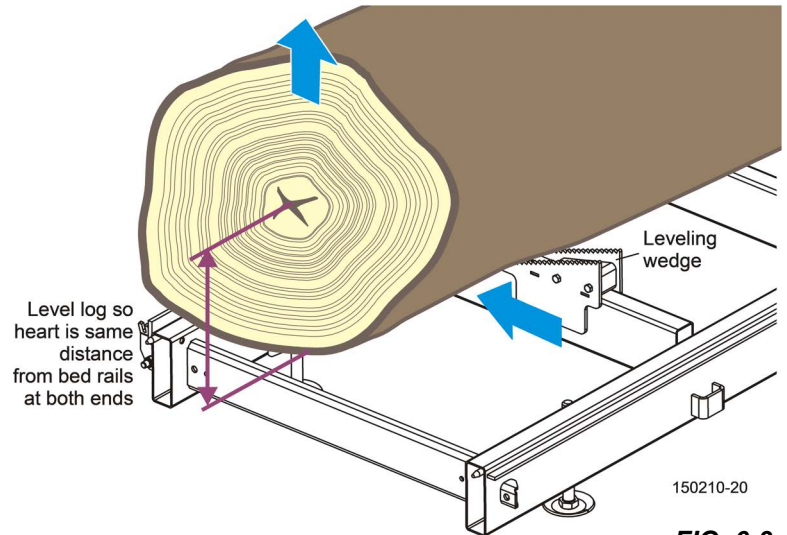
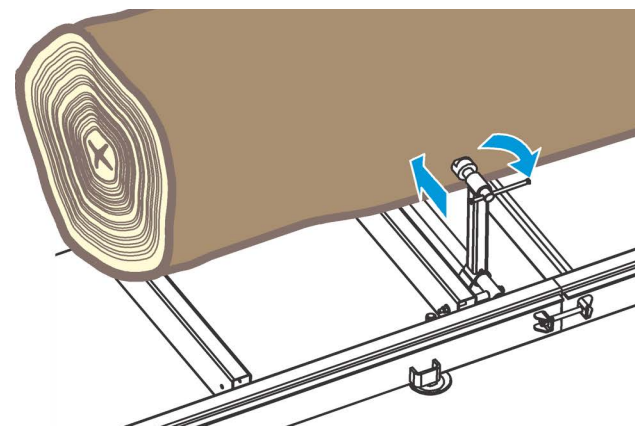

FIG. 6-3

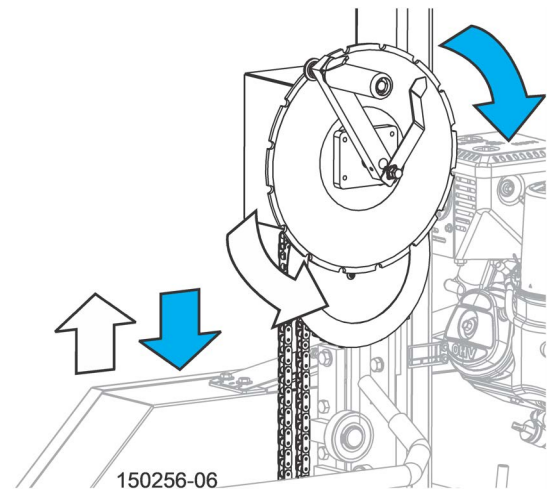

FIG. 6-4

*.Also available as part of the LT15OP, Optional Package Kit for the LT15.

3. Pull the lever toward you to move the arm in; push the lever away from you to move the arm out. See FIG. 6-6.

6.4 Clutch Operation

1. Clear any loose objects from the area of the blade, motor, and drive belt.
2. Make sure the clamp and side supports are adjusted below the level of your first few cuts.
3. Start the engine as instructed in the option manual.



DANGER! Keep all persons out of the path of moving equipment and logs when operating sawmill or loading and turning logs.

4. Ensure the blade housing and pulley covers are in place and secure before starting the engine or motor.
5. Use the rubber latches to fasten the blade housing covers shut.

The clutch lever is located next to the engine. See FIG. 6-6.

6. Engage the blade by pushing the clutch lever down until it locks in the down position, thus engaging the drive mechanism and increasing the engine speed to full throttle.
7. Disengage the blade by raising the clutch lever to the up position, thus disengaging the drive belt and returning the engine to idle.

6.5 Cutting The Log

1. Position the log and clamp firmly.
2. Move the saw head to position the blade close to the end of the log.
3. Use the blade height scale to determine where to make your first cut ([See 6.7](#)).

The blade height scale will help you to do this. Set the blade to the desired height with the up/down crank. Make sure that the blade will clear all side supports and the clamps. Adjust the outer blade guide to clear the widest section of the log by moving the blade guide arm knob.

4. Engage the clutch to start the blade spinning.
5. Start the water lube if necessary to prevent sap buildup on the blade. [See 6.8](#).
6. Feed the blade into the log slowly ([See Section 5.4](#)).

Once the blade completely enters the log, increase the feed rate as desired. Always try to cut at the fastest speed you can while keeping an accurate cut. Cutting too slowly will waste blade life and lower production!

7. As you get to the end of the log, slow down the feed rate.
8. Disengage the clutch when the teeth exit the end of the log; remove the slab that you have just cut from the log.
9. Repeat until the first side of the log is cut as desired.
10. Set aside the usable flitches (boards with bark on one or both sides) to edge them later.
11. Remove the wedge if it was used.
12. Remove the clamps and turn the log 90 or 180 degrees.
13. Make sure the flat on the log is placed flat against side supports if turned 90 degrees.
14. Make sure it is placed on bed rails if turned 180 degrees.

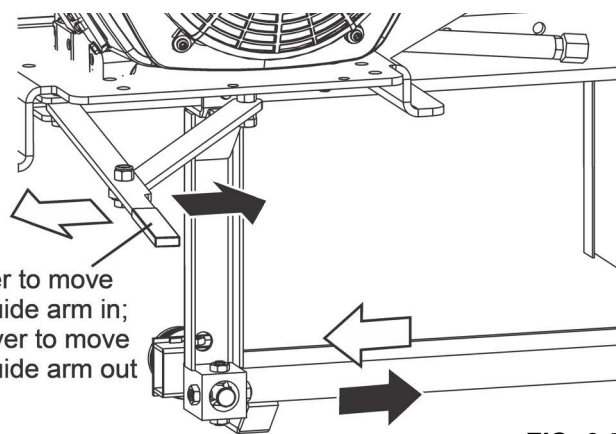

FIG. 6-5

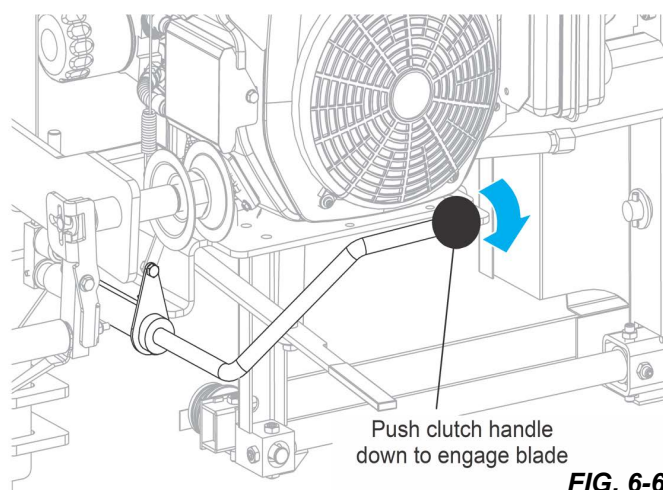

FIG. 6-6

15. If the log was turned 90 degrees and you are using the wedge to compensate for taper in the log, use the wedge again on the second side of the log until the heart is parallel with the bed.
16. Repeat the steps used to cut the first side of the log until the log is square. Cut boards from the remaining cant by adjusting the blade height for the thickness of boards that you want.

Example: Remember that the blade cuts a 1/16 - 1/8" (1.6-3.2 mm) wide kerf. If you want 1" (25.4 mm) thick boards, lower the carriage 1 1/16 - 1 1/8" (27-28.6 mm) for each board.

6.6 Edging

1. Raise the side supports to 1/2 the height of the flitches, or the boards that need to be edged.
2. Stack the flitches on edge against the side supports.
3. Clamp the flitches against the side supports halfway up the flitch height.
 - 1). Place the wider flitches to the clamp side.
 - 2). When they are edged, flip them over to edge the second side without disturbing the other flitches or without having to pull them from the middle of the stack.
4. Adjust the blade height to edge a few of the widest boards.
5. Loosen the clamps and turn the edged boards over to edge the other side.
6. Repeat steps 2-4.
7. Loosen the clamps and remove the boards that have good clean edges on both sides.
8. Clamp the remaining flitches and repeat steps 2-5.

6.7 Blade Height Scale

The blade height scale includes a blade height indicator, an inch scale, and a magnetic quarter scale. See FIG. 6-6.

THE INCH SCALE

The horizontal line on the blade height indicator shows how many inches the bottom of the blade is above the bed of the mill. If you know the height of your blade at each cut, you can determine the thickness of lumber you are sawing.

Example: You want to cut 1" (25 mm) random width boards from a log. Position the blade for the first cut. Move the carriage to an even measurement on the inch scale. Make a trim cut. Return the carriage for the second cut and lower it 1 1/8" (29 mm) below the original measurement. (The extra 1/8" (3 mm) allows for saw kerf and shrinkage of the lumber.)

The yellow area on the scale identifies where the blade could encounter a side support or log clamp. Check that these items are below the blade level before sawing.

THE QUARTER SCALE

The magnetic quarter scale has four sets of marks. Each set represents a specific lumber thickness. Saw kerf and shrinkage allowance are included, but actual board thickness will vary slightly depending on blade thickness and tooth set. See Table 6-1.

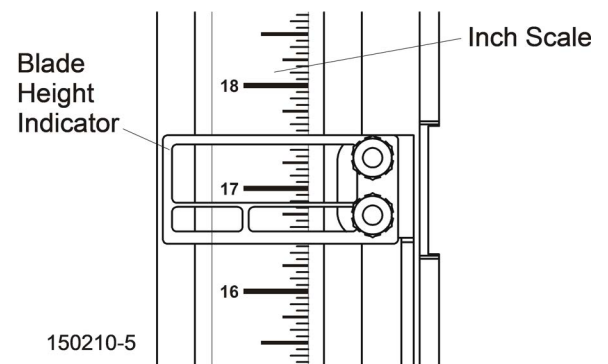

FIG. 6-7

To use the quarter scale, look at the blade height indicator.

Position the magnetic quarter scale over the inch scale. Align one of the quarter scale marks with the horizontal line on the indicator.

Make a trim cut. When you return the carriage for a second cut, lower the carriage to the next mark on the scale. This mark shows where the blade should be positioned to cut a certain thickness of lumber, without having to measure on the inch scale.

Example: You want to cut 1" (25 mm) (4/4) random width boards from a log. Position the blade for the first cut. Position the magnetic quarter scale so a 4/4 mark is aligned with the line on the indicator. Make a trim cut.

Return the carriage for the second cut. Now, instead of having to measure down 1 1/8" (29 mm) on the inch scale, you can simply lower the blade so the indicator is aligned with the next 4/4 mark on the quarter scale. Turn the log 90 degrees and repeat.

Standard Quarter Scale	
Scale	Actual Board Thickness
4/4	1" (25 mm)
5/4	1 1/4" (32 mm)
6/4	1 1/2" (38 mm)
8/4	2" (51 mm)

TABLE 6-1

6.8 Water Lube Operation

The Water Lube System keeps the blade clean. Water flows from a 5-gallon (18.9 liter) bottle through a hose to the blade guide where the blade enters the log. A valve in the bottle cap controls the amount of water flow. See FIG. 6-8.

Not all types of wood require the use of the Water Lube System. When it is needed, use just enough water to keep the blade clean. This saves water, and lowers the risk of staining the boards with water. Usual flow will be 1-2 gallons (3.8-7.6 liters) per hour.

Before removing the blade, engage the blade. Let the blade spin with water running on it for about 15 seconds to clean the blade of sap buildup. Wipe the blade dry with a rag before storing or sharpening.

For further lubrication benefits, add one 12oz. (0.35L) bottle of Wood-Mizer Lube Additive to 5 gallons (18.9 liters) of water. Wood-Mizer Lube Additive enables some difficult timbers to be cut by significantly reducing resin buildup on the blade, heat buildup, wavy cuts, and blade noise. This biodegradable and environmentally-friendly pre-mix includes a water softener additive to work with hard water.

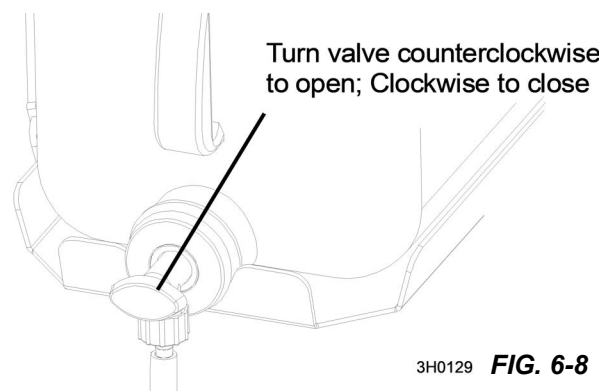

3H0129 **FIG. 6-8**

WARNING! Use ONLY water and Wood-Mizer Lube Additive with the water lube accessory. DO NOT use flammable fuels or liquids such as diesel fuel. If the blade needs solvents to clean, remove it and wipe it with a rag.

NOTICE If you are sawing in freezing temperatures, remove the water lube bottle from the sawmill when done sawing and store it in a warm place. Blow any remaining water from the water lube hose.

6.9 Loading & Transporting the Sawmill

The assembled sawmill can be manually loaded into and transported in an appropriately equipped pickup truck:

WARNING! A MINIMUM OF THREE PEOPLE (FOUR RECOMMENDED) is required to safely load or unload the sawmill from a pickup truck.

The sawmill weighs 1100 lbs. (500Kg). The center of gravity of the carriage is off-center toward the operator side. The higher the saw head from the bed frame, the more easily the mill can be tipped toward the operator side.

WARNING! Ensure the carriage lock pins are properly engaged.

To prevent the carriage from unexpectedly sliding on the rails, the pin at the end of the sawmill **must engage the hole in the bed frame**. The other pin must be left in the operation position.

1. Remove the leg assemblies or adjust them above the bottom of the bed frame.

See 8.5 for a detailed description of carriage lock pin operation.

CAUTION! Adjust the saw head up just far enough so it will clear the sides of your truck bed when loaded.

NOTE: For most pickup trucks, a minimum of 18" (460mm) between the blade and bed frame cross members should be adequate. Do not adjust the saw head so high that the sawmill will tip easily while being loaded.

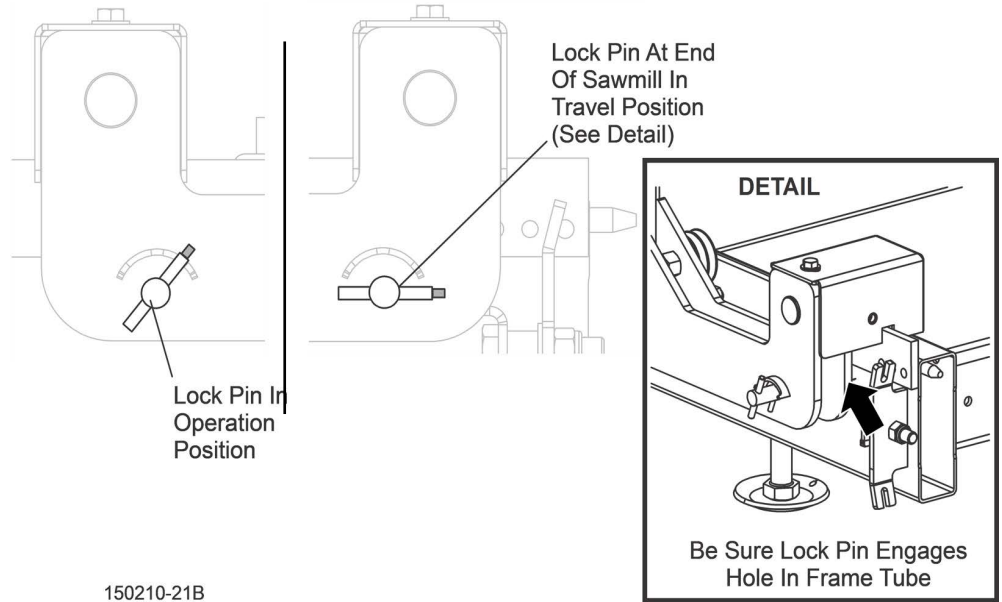

150210-21B

FIG. 6-9

2. Move the carriage to one end of the mill.

3. Rotate and release the lock pin closest to the end of the mill.

CAUTION! Be sure the lock pin engages the hole in the bed frame to secure the saw carriage in place. The other lock pin remains in the operation position. See FIG. 6-9.

4. Remove the tailgate from your truck to eliminate the possibility of damage and/or injury,

5. Position the bed of the truck at the end of the frame **opposite the carriage**.

WARNING! Keep all persons out of the area between the frame rails while loading and unloading the sawmill. Do not lift the sawmill onto the truck using ropes, cables, or chains, etc.; the sawmill can easily rotate and tip over when lifted.

6. Position two people (for lifting) about two feet inward from the end of the frame.

7. As they lift the frame, the third person should back the truck slowly under the sawmill until the end of the frame is resting firmly on the bed of the truck.

CAUTION! The operator side is heavier than the opposite side.



8. Position two people on either side of the saw head to hold the sawhead while a third person pulls and rotates (releases) the lock pin from the locked position to the operation position.

9. Push the saw carriage up the bed frame to the opposite side of the bed frame (on the truck).

NOTE: More people may be required to help push as the saw head gets more difficult to push up the incline.

10. Engage the lock pin at the end of the sawmill to secure the carriage.

CAUTION! Be sure the lock pin engages the hole in the bed frame to secure the saw carriage in place. The other lock pin remains in the operation position.

11. Use **three or more people** to lift the end of the mill still on the ground and slide the sawmill into the truck bed.

12. Secure the sawmill to the truck bed to prevent the sawmill from shifting while it is being transported. **If the sawmill extends beyond the truck bed, attach a red warning flag to the end of the sawmill.**

SECTION 7 MAINTENANCE

This section lists the maintenance procedures that need to be performed.

See the [Maintenance chart](#) located after this section for a complete list of maintenance procedures and intervals. Keep a log of machine maintenance by recording in the machine hours and the date you perform each procedure.

Refer to option and engine manuals for other maintenance procedures.

7.1 Wear Life

Table 7-0 lists estimated life expectancy of common replacement parts if proper maintenance and operation procedures are followed. Due to the many variables which exist during sawmill operation, actual part life may vary significantly. This information is provided so that you may plan ahead in ordering replacement parts.

Part Description	Estimated Life
B57 Blade Wheel Belts	400 hours
Blade Guide Rollers	1000 hours
Drive Belt	1250 hours

TABLE 7-0

7.2 Blade Guides

 **WARNING!** Turn the key switch to the OFF (#0) position and remove the key prior to performing service near moving parts such as blades, pulleys, motors, belts, or chains.

1. Check the rollers for performance and wear every blade change.
2. Make sure the rollers are clean and spinning freely -- if not, replace them.
3. Replace any rollers which have worn smooth or have become cone shaped.

7.3 Sawdust Removal

AS REQUIRED

 **WARNING!** Turn the key switch to the OFF (#0) position and remove the key prior to performing service near moving parts such as blades, pulleys, motors, belts, or chains.

1. Remove the excess sawdust from the blade wheel housings and sawdust chute every blade change.
2. Ensure the steel fingers inside the sawdust chute are in place and in working order.

The steel fingers prevent a broken blades or other objects from becoming a projectile when exiting the sawdust chute.

3. Remove sawdust buildup from rope feed pulleys and up/down chain sprockets as necessary.

7.4 Carriage Track, Wiper & Scrapers

 **WARNING!** Before performing service near moving parts such as blades, pulleys, motors, belts and chains, first turn the key switch to the OFF (#0) position and remove the key.

Properly maintaining the sawmill carriage track is critical in preventing corrosion that can cause pitting and scaling on the rail surfaces. Pitted and scaled surfaces can, in turn, cause rough cuts or jerky feed movement.

EVERY 8 HOURS

1. Clean track rails to remove any sawdust and sap buildup every eight hours of operation.
2. Use a light-grade sandpaper or emery cloth to sand off any rust or other adhering particles from the rails.

 **CAUTION!** Keep track rails free of rust. Formation of rust on the track rail in the areas where the cam bearings roll can cause rapid deterioration of the track rail's surface.

3. Lubricate the rails by wiping them with Dexron III ATF transmission fluid.

NOTE: Lubrication will help protect the rails from corrosive elements such as acid rain and/or moisture from nearby bodies of saltwater (if applicable). This lubrication is essential to maintain the integrity of the track rails and track rollers and to achieve long service life.

EVERY 25 HOURS

4. Remove sawdust from the track roller housings and lubricate the felt track wiper every twenty-five hours of operation.
5. Remove the track roller housing covers and brush any sawdust buildup from the housings.
6. Clean and lubricate the felt track wipers.
 - 1). Unbolt the middle track cover and idle track wipers,
 - 2). Remove any sawdust buildup.
 - 3). Soak the felt wiper with Dexron III transmission fluid.
 - 4). Replace.

AS REQUIRED

7. Check the track scrapers as needed.
8. Adjust so that the scrapers fit firmly against the rail. I
 - 1). Loosen the screw.
 - 2). Push the scraper downward until it fits firmly against the rail.
9. Retighten the screw. See FIG. 7-1.

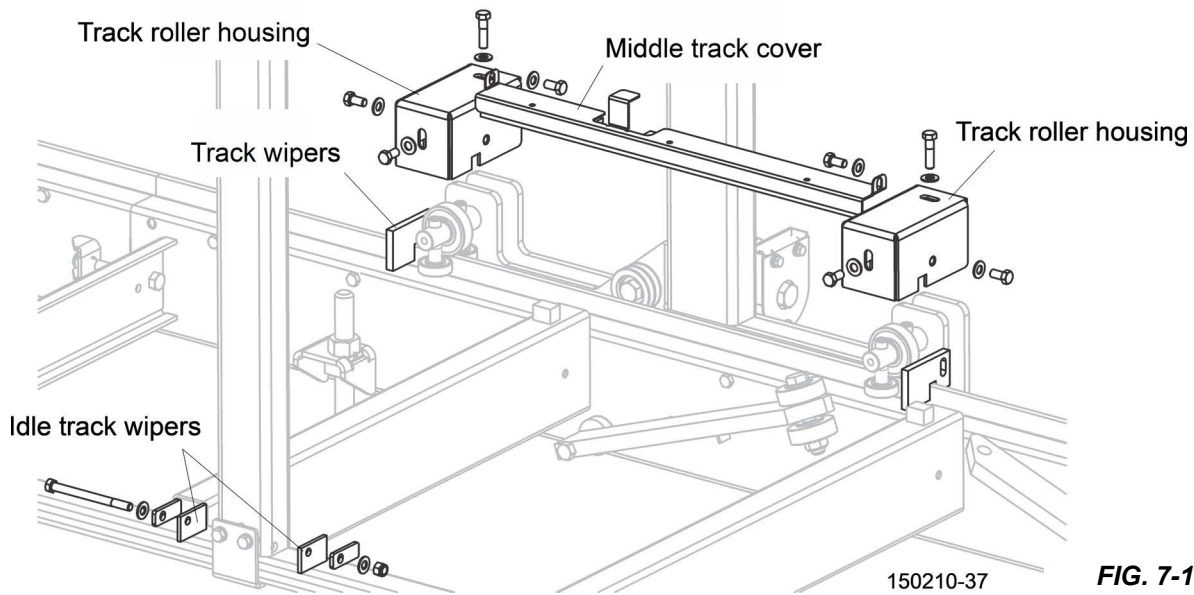

FIG. 7-1

7.5 Vertical Mast Rails

WARNING! Before performing service near moving parts such as blades, pulleys, motors, belts and chains, first turn the key switch to the OFF (#0) position and remove the key.

EVERY 50 HOURS

Clean the vertical mast rails every 50 hours of operation.



CAUTION! Do not use grease on the mast rails; it will collect sawdust.

7.6 Miscellaneous

 **WARNING!** Before performing service near moving parts such as blades, pulleys, motors, belts and chains, first turn the key switch to the OFF (#0) position and remove the key.

EVERY 50 HOURS

1. Oil all chains with Dexron III ATF every fifty hours of operation.

 **CAUTION!** Do not use chain lube. It causes sawdust buildup in chain links.

2. Grease the clamps and side support pivots with a NLGI No. 2 grade lithium grease every fifty hours of operation.
3. Check the mill alignment every setup ([See SECTION 7](#)).
4. Make sure all safety warning decals are readable. Remove sawdust and dirt. Replace any damaged or unreadable decals immediately. Order decals from your Customer Service Representative.

7.7 Blade Wheel Belts

 **WARNING!** Before performing service near moving parts such as blades, pulleys, motors, belts and chains, first turn the key switch to the OFF (#0) position and remove the key.

EVERY 50 HOURS

Rotate the blade wheel belts and check them for wear. Rotating the belts **every 50 hours** will provide longer belt life. Replace belts as necessary. Use only B57 belts supplied by Wood-Mizer.

7.8 Drive Belt Adjustment

 **WARNING!** Disconnect and lockout power before performing any service to the electrical system. For battery-powered equipment, disconnect the negative battery terminal cable. Failure to follow this may result in injury and/or electrical system damage.

Before performing service near moving parts such as blades, pulleys, motors, belts and chains, first turn the key switch to the OFF (#0) position and remove the key.

Do not adjust the engine drive belts or belt support bracket with the engine running.

Measure the belt tension with a gauge. **NOTE:** Wood-Mizer offers a belt tension gauge (Part No. 016309) that will let you accurately measure the belt tension

1. At first installation of a new belt, the deflections should be 14 lbs (6.35kg) at 1/2" (13mm).
2. Check the tension again **after 20 hours** of operation.
3. Check **every 50 hours** after second check.

All reading should remain **14 lbs (6.35kg) at 1/2" (13mm)**.

ADJUST THE DRIVE BELT TENSION

1. Loosen the drive belt jam and hex nuts. Turn the jam nut counterclockwise (as viewed from the top) to tighten the belt.

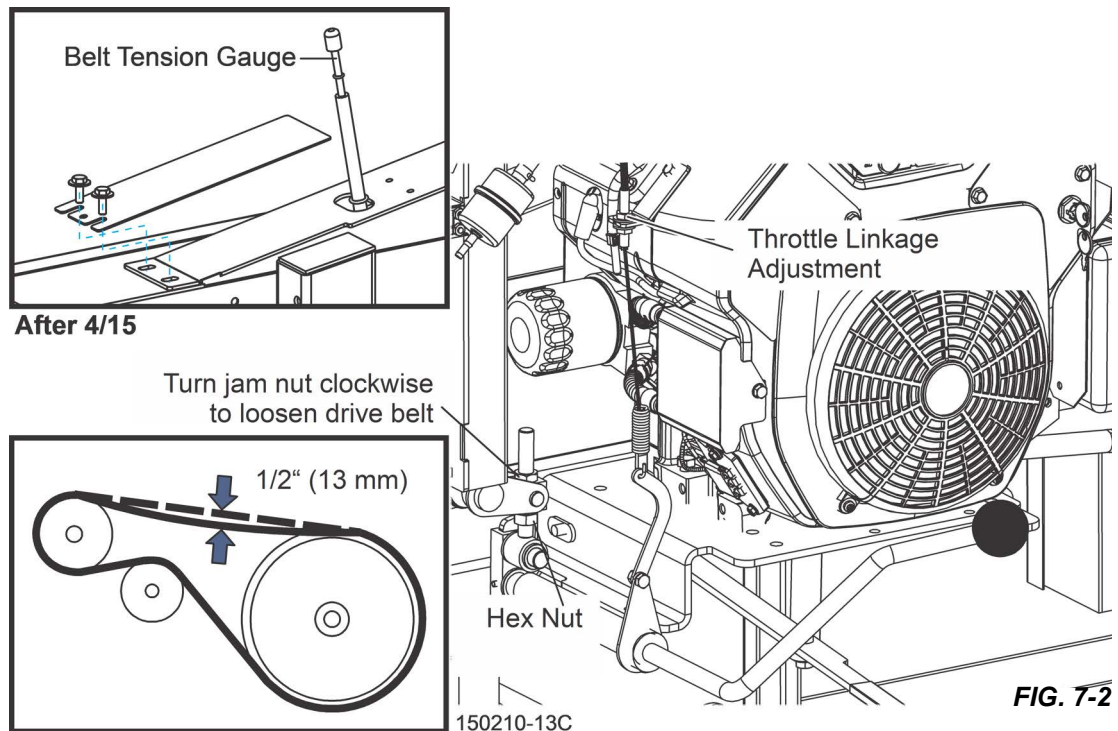

2. **GAS OPTION ONLY:** After tensioning the drive belt, check the throttle linkage and adjust if necessary.

NOTE: With the clutch handle engaged, the throttle linkage should move the throttle lever to full speed. To adjust, loosen the throttle linkage adjustment screw and slide the throttle linkage down. Retighten the screw.

Periodically check the drive belt for wear. Replace any damaged or worn belts as needed.

ADJUST THE DRIVE BELT SUPPORT

The drive belt support is designed to extend belt life. The bracket should be adjusted to **NOT** touch the drive belt when the clutch handle is engaged (down position), **AND** to hold the drive belt away from the engine pulley when the clutch handle is disengaged (up position).

1. Adjust the drive belt support as required.
 - 1). Loosen the adjustment bolt.
 - 2). Position the bracket so that the prong is close to, but **does not touch**, the drive belt with the clutch handle engaged.
 - 3). Retighten the adjustment bolts 25-27 foot pounds. (34-37 N m).

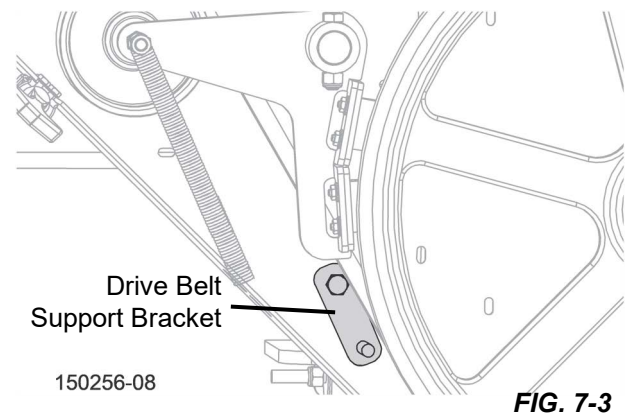

CAUTION! Do not over-tighten the drive belt. Damage to the engine may result.

7.9 Up/Down System



WARNING! Before performing service near moving parts such as blades, pulleys, motors, belts and chains, first turn the key switch to the OFF (#0) position and remove the key.

ADJUST THE UP/DOWN CHAIN TENSION AS NEEDED

1. Measure chain tension with the head all the way to the top of the vertical mast.

WARNING! When servicing the saw head or areas near the saw head, always secure the saw head with a chain with at least 1900lbs working load capacity. Alternatively, the saw head can be secured with a sturdy wood block placed between the saw head and sawmill frame. See Safety section for details. The cutting head may fall, causing severe injury or death.

2. Locate the chain adjusting bolt at the bottom of the mast.
3. Loosen the nut on the sprocket bolt and move the sprocket down until there is about 1" (2.5 cm) total deflection in the center of the chain with a 5 lb. (2.3 Kg) deflection force.

A chain tension adjustment bracket/bolt is provided on the sprocket assembly.

4. Loosen the jam nut and tighten the adjustment bolt to pull the sprocket down and tension the chain.
5. Retighten the jam nut and sprocket nut after tensioning the chain. See FIG. 7-4. .

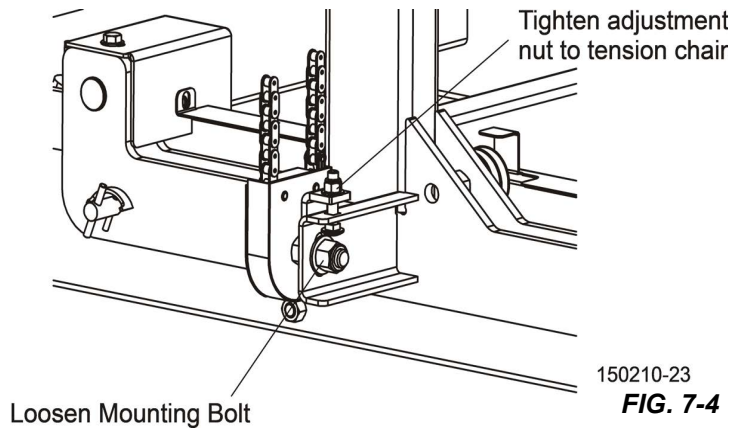

Lubricate the up/down crank handle bearings every **200 hours** with a NLGI No. 2 grade lithium grease. Apply the grease to the fitting on the handle bracket tube. See FIG. 7-5.

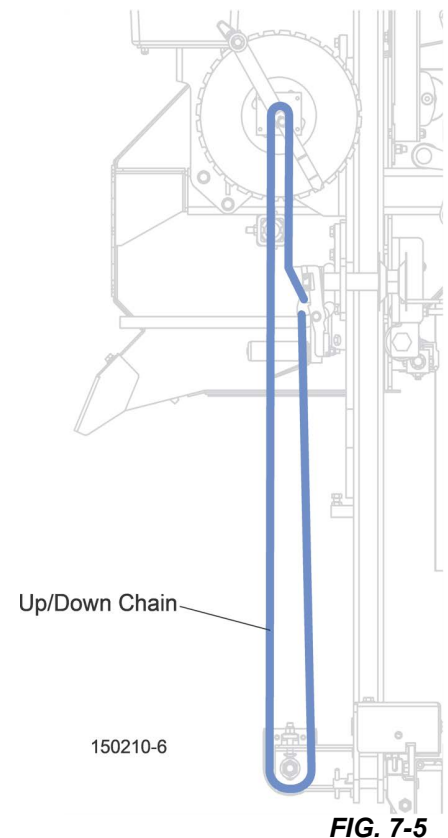
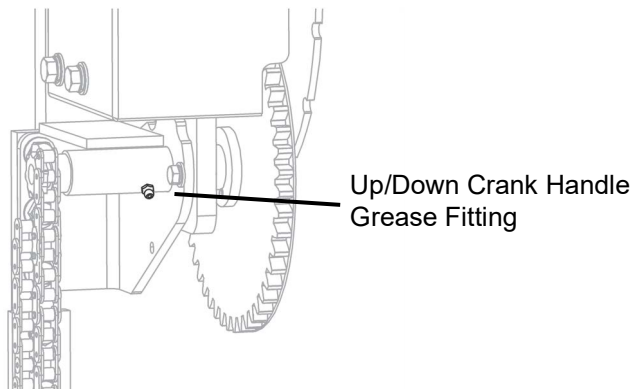

7.10 Maintenance chart

MAINTENANCE LOG (Check <i>Engine And Option Manuals</i> for additional maintenance procedures)	MANUAL REFERENCE	MAINTENANCE INTERVAL
Clean sawdust from, battery box lid & track cover	<u>See Section 7.3</u>	8 hours
Clean and lubricate track	<u>See Section 7.4</u>	8 hours
Inspect lift assist cables	<u>See Section 7.9</u>	8 hours
Check blade guide roller wear	<u>See Section 7.2</u>	8 hours Every blade change
Remove excess sawdust from blade wheel housings and sawdust chute	<u>See Section 7.3</u>	8 hours Every blade change
Inspect fingers inside sawdust chute	<u>See Section 7.3</u>	8 hours Every blade change
Remove sawdust from upper track roller housings	<u>See Section 7.4</u>	25 hours
Clean & lube mast rails	<u>See Section 7.5</u>	50 hours
Grease pivot points and bearings/oil chains	<u>See Section 7.6</u>	50 hours
Rotate drive/idle blade wheel belts/check for wear	<u>See Section 7.7</u>	50 hours
Check belt tensions	<u>See Section 7.8</u>	50 hours
	<u>See Section 7.9</u>	50 hours

SECTION 8 TROUBLESHOOTING GUIDE

8.1 Sawing Problems

 **WARNING!** Before performing service near moving parts such as blades, pulleys, motors, belts and chains, first turn the key switch to the OFF (#0) position and remove the key.

PROBLEM	CAUSE	SOLUTION
Blades Dull Quickly	Dirty logs	Clean or debark logs, especially on entry side of the cut
	When grinding teeth, heating too much and causing teeth to soften	Grind just enough metal to restore sharpness. Use water/coolant while sharpening blade
	Poor sharpening techniques	Make sure the tip is being sharpened completely: Read the instructions with your blade sharpening equipment carefully
Blades Break Prematurely	Poor sharpening techniques	Read the instructions with your blade sharpening equipment carefully
	Tension too tight	Tension blade to recommended specifications
Blade Does Not Track Right on Drive Wheel	Cant adjustment is incorrect	Readjust
Drive Belts Wear Prematurely or Jump	Engine/motor drive pulleys out of alignment	Align pulleys
Boards Thick Or Thin On Ends Or Middle Of Board.	Stress in log which causes log to not lay flat on the bed.	After log has been squared, take equal cuts off opposing sides. Take a board off the top. Turn the log 180 degrees. Take a board off. Repeat, keeping the heart in the middle of the cant, and making it your last cut.
	Set in teeth.	Resharpen and reset blade.
	Bed rails misaligned.	Realign sawmill.
Height Adjustment Jumps or Stutters When Moving Up or Down.	Up/down chain improperly adjusted.	Adjust up/down chain.
Lumber Is Not Square	Vertical side supports not square to bed	Adjust side supports.
	Blade not parallel to bed rails	Adjust bed rails parallel to blade.
	Sawdust or bark between cant and bed rails	Remove particles
	Tooth set problems	Resharpen and reset blade
Sawdust Builds Up On Track	Excessive oiling	Do not oil track
	Track wipers worn	Adjust wipers to firmly contact track
	Track is sticky	Clean track with solvent and apply silicone spray
Wavy Cuts	Excessive feed	Slow feed rate
	Improperly sharpened blade (This will be the problem 99% of the time!)	Resharpen blade, following the sharpener's instructions carefully
	Blade guides improperly adjusted	Adjust blade guides.
	Sap buildup on blade	Use Water Lube.
	Tooth set problem	Resharpen and reset blade