

Wood-Mizer[®] Sawmill

Safety, Setup, Operation & Maintenance Manual

LT60HD
LT70HD

rev. B3.02 - B7.00
rev. B3.02 - B7.00



Safety is our #1 concern! Read and understand all safety information and instructions before operating, setting up or maintaining this machine.

January 2010

Form #1667

California

Proposition 65 Warning



WARNING: Breathing gas/diesel engine exhaust exposes you to chemicals known to the State of California to cause cancer and birth defects or other reproductive harm.

Always start and operate the engine in a well-ventilated area.
If in an enclosed area, vent the exhaust to the outside.
Do not modify or tamper with the exhaust system.
Do not idle the engine except as necessary.

For more information go to **www.P65warnings.ca.gov**.



WARNING: Drilling, sawing, sanding or machining wood products can expose you to wood dust, a substance known to the State of California to cause cancer. Avoid inhaling wood dust or use a dust mask or other safeguards for personal protection.

For more information go to **www.P65Warnings.ca.gov/wood**.

©2019

Printed in the United States of America, all rights reserved. No part of this manual may be reproduced in any form by any photographic, electronic, mechanical or other means or used in any information storage and retrieval system without written permission from

Wood-Mizer
8180 West 10th Street
Indianapolis, Indiana 46214

Table of Contents

Section-Page

SECTION 1	INTRODUCTION	1-1
1.1	About This Manual.....	1-1
1.2	Getting Service.....	1-2
	<i>General Contact Information.....</i>	<i>1-2</i>
	<i>Wood-Mizer Locations.....</i>	<i>1-3</i>
1.3	Specifications	1-4
1.4	Customer and Sawmill Identification.....	1-7
1.5	Warranty.....	1-9
SECTION 2	SAFETY	2-1
2.1	Safety Symbols.....	2-1
2.2	Safety Instructions.....	2-2
2.3	Electrical Lockout Procedures.....	2-12
SECTION 3	SAWMILL SETUP	3-1
3.1	Stationary Sawmill Setup.....	3-1
3.2	Portable Sawmill Setup.....	3-3
3.3	Replacing The Blade.....	3-6
3.4	Tensioning The Blade.....	3-8
3.5	Tracking The Blade.....	3-13
3.6	Starting The Engine (or Motor).....	3-15
3.7	Board Return.....	3-16
SECTION 4	SAWMILL OPERATION	4-1
4.1	Hydraulic Control Operation.....	4-1
4.2	Loading, Turning And Clamping Logs.....	4-4
4.3	Up/Down Operation.....	4-6
4.4	Blade Guide Arm Operation.....	4-7
4.5	Autoclutch Operation.....	4-8
4.6	Power Feed Operation.....	4-9
4.7	Cutting The Log.....	4-11
4.8	Edging.....	4-12
4.9	Optional Cutting Procedure.....	4-13
4.10	Blade Height Scale.....	4-14
4.11	Water Lube Operation.....	4-16
4.12	Preparing The Sawmill For Towing.....	4-18
SECTION 5	MAINTENANCE	5-1
5.1	Wear Life.....	5-1
5.2	Blade Guides.....	5-2
5.3	Sawdust Removal.....	5-4
5.4	Carriage Track, Wiper & Scraper.....	5-5
5.5	Vertical Mast Rails.....	5-7

Table of Contents

Section-Page

5.6	Drum Switches	5-8
5.7	Miscellaneous	5-9
5.8	Blade Tensioner.....	5-10
5.9	Blade Wheel Belts	5-13
5.10	Drive Belt Adjustment.....	5-14
	<i>Adjust belt tension.....</i>	<i>5-15</i>
	<i>Adjust the drive belt support (Excludes E25, E30, D55)</i>	<i>5-16</i>
5.11	Brake Adjustment (DC Only).....	5-17
5.12	Autoclutch Belt (DC Only)	5-18
5.13	Hydraulic System	5-19
5.14	Up/Down System.....	5-21
5.15	Power Feed	5-26
5.16	Charging The Battery (DC Only).....	5-28
5.17	Turner Chain Tension.....	5-30
5.18	Maintenance chart	5-31
5.18	MAINTENANCE LOG	5-31
SECTION 6	TROUBLESHOOTING GUIDE	6-1
6.1	Sawing Problems	6-1
6.2	Electrical Problems.....	6-3
6.3	Circuit Breaker Operation	6-5
6.4	Power Feed Problems	6-7
6.5	Power Feed Variable Feed Rate Switch Test	6-9
6.6	Power Feed Mechanical Test.....	6-10
6.7	Hydraulic Problems	6-11
6.8	Hydraulic Pressure Test.....	6-15
6.9	Engine/Motor and Drive Pulleys Alignment.....	6-16

Table of Contents

Section-Page

SECTION 7	SAWMILL ALIGNMENT	7-1
7.1	Routine Alignment Procedure7-1	
	<i>Blade Installation..... 7-1</i>	
	<i>Saw Head Tilt..... 7-1</i>	
	<i>Blade Guide Arm Alignment..... 7-3</i>	
	<i>Blade Guide Vertical Tilt Alignment..... 7-7</i>	
	<i>Blade Guide Horizontal Tilt Adjustment..... 7-8</i>	
	<i>Blade Guide Flange Spacing 7-10</i>	
	<i>Manual Side Support Alignment 7-11</i>	
	<i>Hydraulic Side Support Alignment 7-13</i>	
	<i>Blade Height Scale Adjustment..... 7-14</i>	
7.2	Complete Alignment Procedure7-16	
	<i>Frame Setup 7-16</i>	
	<i>Blade Installation..... 7-16</i>	
	<i>Blade Wheel Alignment..... 7-17</i>	
	<i>Track Roller Adjustment 7-21</i>	
	<i>Bed Rail Adjustment..... 7-24</i>	
	<i>Blade Guide Installation..... 7-26</i>	
	<i>Blade Guide Arm Alignment..... 7-28</i>	
	<i>Blade Guide Deflection..... 7-33</i>	
	<i>Blade Guide Vertical Tilt Alignment..... 7-33</i>	
	<i>Blade Guide Horizontal Tilt Adjustment..... 7-35</i>	
	<i>Blade Guide Flange Spacing 7-36</i>	
	<i>Blade Guide Level..... 7-37</i>	
	<i>Blade Block Adjustment 7-38</i>	
	<i>Manual Side Support Alignment 7-40</i>	
	<i>Hydraulic Side Support Alignment 7-41</i>	
	<i>Clamp Stop/Stop Bolt Adjustment..... 7-42</i>	
	<i>Saw Head Tilt..... 7-43</i>	
	<i>Blade Height Scale Adjustment..... 7-45</i>	
SECTION 8	HYDRAULIC INFORMATION	8-1
8.1	Hydraulic Schematic8-1	
8.2	Hydraulic Layout Diagram8-2	
8.3	Hydraulic Components.....8-3	
8.4	Hydraulic Hoses8-4	
	INDEX	I

SECTION 1 INTRODUCTION

1.1 About This Manual

This manual is to replace or to be used with all previous information received on the Wood-Mizer® sawmill. All future mailings will be an addition to or a revision of individual sections of this manual as we obtain new information.

The information and instructions given in this manual do not amend or extend the limited warranties for the equipment given at the time of purchase.

For general information regarding Wood-Mizer and our “Forest to Final Form” products, please refer to the All Products Catalog in your support package.

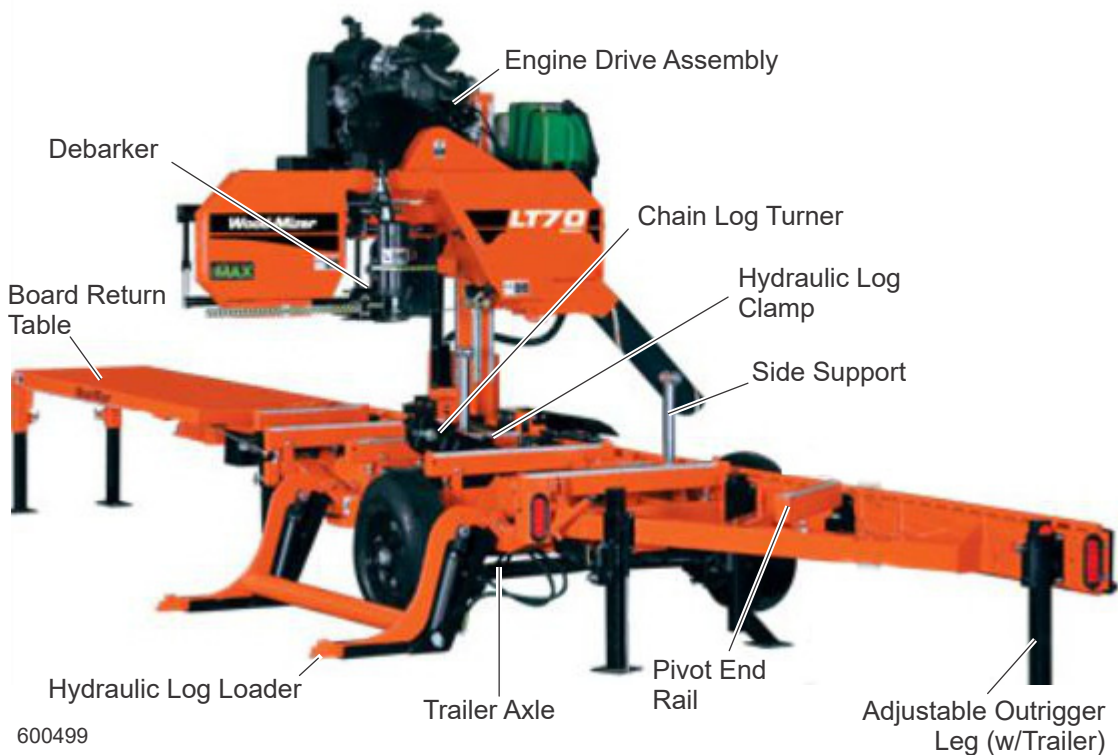

MILL COMPONENTS

*.Wood-Mizer® is a registered trademark of Wood-Mizer LLC.

1.2 Getting Service

Wood-Mizer is committed to providing you with the latest technology, best quality and strongest customer service available on the market today. We continually evaluate our customers' needs to ensure we're meeting current wood-processing demands. Your comments and suggestions are welcome.

General Contact Information

Toll free phone numbers are listed below for the *continental* U.S. and Canada. See the next page for contact information for more Wood-Mizer locations.

	United States	Canada
Sales	1-800-553-0182	1-877-866-0667
Service	1-800-525-8100	1-877-866-0667
Website	www.woodmizer.com	www.woodmizer.ca
E-mail	woodmizer@woodmizer.com	oninfo@woodmizer.com

Office Hours: All times are Eastern Standard Time.

Monday - Friday	Indianapolis Office ONLY Saturday	Sunday
8 a.m. to 5 p.m.	8 a.m. to 12 p.m.	Closed

Please have your vehicle identification number and your customer number ready when you call.

Wood-Mizer will accept these methods of payment:

- Visa, Mastercard, or Discover
- COD
- Prepayment
- Net 15 (with approved credit)

Be aware that shipping and handling charges may apply. Handling charges are based on size and quantity of order. In most cases, items will ship on the day they are ordered. Second Day and Next Day shipping are available at additional cost.

If your sawmill was purchased outside the United States or Canada, contact the distributor for service.

1**Introduction***Wood-Mizer Locations***Wood-Mizer Locations**

<p>USA World Headquarters</p> <p><i>Serving North & South America, Oceania, East Asia</i></p> <p>Wood-Mizer LLC 8180 West 10th Street Indianapolis, IN 46214</p> <p>Phone: 317.271.1542 or 800.553.0182 Customer Service: 800.525.8100 Fax: 317.273.1011 Email: infocenter@woodmizer.com</p>	<p>Canadian Headquarters</p> <p><i>Serving Canada</i></p> <p>Wood-Mizer Canada 396 County Road 36, Unit B Lindsay, ON K9V 4R3</p> <p>Phone: 705.878.5255 or 877.357.3373 Fax: 705.878.5355 Email: ContactCanada@woodmizer.com</p>
<p>Brazilian Headquarters</p> <p><i>Serving Brazil</i></p> <p>Wood-Mizer do Brasil Rua Dom Pedro 1, No: 205 Bairro: Sao Jose Ivoti/RS CEP:93.900-000</p> <p>Tel: +55 51 9894-6461/ +55 21 8030-3338/ +55 51 3563-4784 Email: info@woodmizer.com.br</p>	<p>European Headquarters</p> <p><i>Serving Europe, Africa, West Asia</i></p> <p>Wood-Mizer Industries Sp z o.o. Nagorna 114 62-600 Kolo, Poland</p> <p>Phone: +48.63.26.26.000 Fax: +48.63.27.22.327</p>
<p>Branches & Authorized Sales Centers</p> <p>For a complete list of dealers, visit www.woodmizer.com</p>	

1.3 Specifications

Model: LT60HD Rev. A5.00 - A7.06

Dimensions:

Length: 21'-11"
Width: 6'-3"
Height (Ground To Mast): 7'-5 1/2"
Height (Max Head Position): 12'-0"
Bed Height (Ground To Bed): 29"
Blade Length: 184"

Weights:	D51	D62	D42	E25	D55
Basic Unit (Wet):	3965 lbs	4005 lbs	3915 lbs	3786 lbs	3876 lbs
w/Trailer:	4390 lbs	4430 lbs	4340 lbs	4211 lbs	4301 lbs
Tongue Weight:					

Trailer:

Axle Capacity: 5080 lbs
Tire Capacity: 2540 lbs
Tire Size: ST225/75R15
Weight: 425 lbs

Log Capacity:

Length: 15'-11"
Diameter: 36"
Weight: 4400 lbs.
Max Clamp Width (from stop block): 26"
Max Throat Width (guide to guide): 29"
Max Cant Width (outer guide to stop block): 25 1/2"

Engine:	D51	D62	D42	E25	D55
Manufacturer:	Caterpillar	Caterpillar	Kubota	Lincoln	Yanmar
Fuel:	Diesel	Diesel	Diesel	Electric	Diesel
Horsepower Rating:	51	62	42	25	55.2
Weight:	485 lbs	525 lbs	435 lbs	263 lbs	396 lbs
Idle Speed:	1500 RPM	1500 RPM	1500 RPM	3500 RPM	1500 RPM
High Throttle Speed (No Load):	3100 RPM	2950 RPM	3200 RPM	3500 RPM	2800 RPM
Noise Level - @ operator position:	92 dBA	92 dBA	98 dBA	75 dBA	72 dBA
Noise Level - 20 feet away:	84 dBA	84 dBA	87 dBA		
Noise Level - 200 feet away:		70 dBA		63 dBA	
Blade Speed (No Load):	sfpm	5620 sfpm	sfpm	6114 sfpm	
Fuel Consumption (per hour):	1.5 gal	1.5 gal.	1 gal.	20 KwHr	
Cooling System:	Water	Water	Water	N/A	Water
Drive Shaft O.D.:	1 7/16"	1 7/16"	1 7/16"	1 5/8"	1 7/16"
Drive Pulley O.D.:	5.5"	5.5"	5.5"	5"	5.5"
Drive Belt:	3/5VX950	3/5VX950	3/5VX950	3/5VX950	3/5VFX950
Blade Braking:	6-7 Seconds	6-7 Seconds	6-7 Seconds	6-7 Seconds	6-7 Seconds
Oil Capacity w/Filter:	10 qts.	10.6 qts.	6.7 qts.	N/A	7.8 qts.
Battery:	12V 1100CCA	12V 1100CCA	12V 1100CCA	N/A	12V 1100CCA
Alternator Output:	190 Amps	190 Amps	190 Amps	N/A	190 Amps
Alternator Belt:	6PK415	6PK415	6PK400	N/A	6PK1145

Rates:	D51	D62	D42	E25	D55
Max. Forward (Not Cutting):	205 ft./min.	182 ft./min.		208 ft./min.	
Reverse:	200 ft./min.	186 ft./min.		206 ft./min.	
Hourly Production (Average range w/experienced operators/average size logs):	up to 850 bdf.				
Saw Head Up (24"):	6.72 sec.	11.68 sec.	8.71 sec.	8.94 sec.	
Saw Head Down (24"):	5.63 sec.	7 sec.	5.36 sec.	7.57 sec.	

Options:

Single/Lap Siding Option: 143 lbs.
Debarker: lbs.
Laser Sight: lbs.
6' Bed Extension: 390 lbs.
12' Bed Extension: 758 lbs.
24' Bed Extension: 1122 lbs.
Accuset: 13 lbs
Operator Seat: 112 lbs.
Resaw Attachment (DC only): 231 lbs.

±1/32" per drop

Electrical Requirements (E25):	E25-L			E25-H				E25-C
Voltage (3Ph 50/60Hz ±5%):	208	220	230	380	415	440	460	575
Fuse Disconnect - Saw Control:	100 Amp	100 Amp	100 Amp	60 Amp	60 Amp	60 Amp	60 Amp	60 Amp
Time Delay Fuse - Saw Control:	100 Amp	100 Amp	100 Amp	60 Amp	50 Amp	50 Amp	50 Amp	40 Amp
Suggested Wire Size - Saw Control (50' max.):	3AWG	3AWG	3AWG	6AWG	6AWG	6AWG	6AWG	6AWG
Fuse Disconnect - Hydraulic Control:	30 Amp	30 Amp	30 Amp	30 Amp	30 Amp	30 Amp	30 Amp	30 Amp
Time Delay Fuse - Hydraulic Control:	16 Amp	16 Amp	16 Amp	8 Amp	8 Amp	8 Amp	8 Amp	8 Amp
Suggested Wire Size - Hydraulic Control (50' max.):	12AWG	12AWG	12AWG	14AWG	14AWG	14AWG	14AWG	14AWG

RotoPhase Option (converts 1Ph to 3Ph):

Voltage (1Ph 50/60Hz): 230
Main Disconnect: 200 Amp
Fused Disconnect: 200 Amp
Time Delay Fuse: 125 Amp
Output: 100 Amp
Wire Size: 1/0AWG+

1 Introduction

Specifications

Model: LT70 Rev. B4.07+

Dimensions:		Metric	Wide Saw Head Only:
	Length: 26'-4"	8.02m	26'-4"
	Width: 7'-2"	2.18m	7'-8" (2.33m)
	Height (Ground To Mast): 7'-6"	2.28m	7'-6"
	Height (Max Head Position): 10'-4"	3.05m	10'-4"
	Bed Height (Ground To Bed): 29 1/2"	0.75m	29 1/2"
	Blade Length: 184"	4.67m	196" (4.97m)

Weights:

Basic Unit with Trailer(with heaviest power option):
Tongue Weight:

Trailer:

Axle Capacity: 5040 lbs 2286kg
Tire Capacity: 2835 lbs 1285kg
Tire Size: LT225/75/R16E

Cutting Capacity:

			Wide Saw Head Only:
	Length: 20'-2"	6.14m	20'-2"
	Diameter: 36"	0.91m	36"
	Maximum Log Weight: 4400 lbs	1995kg	4400 lbs
	Max Clamp Width (from stop block): 26"	0.66m	26"
	Max Throat Width (guide to guide): 28 1/2"	0.72m	34 1/2" (0.88m)
	Max Cant Width (outer guide to stop block): 25 5/8"	0.65m	31 5/8" (0.8m)
	Min. Cut Height: 1"	25.4mm	1"
	Max. Cut Height: 35 3/16"	0.9m	35 3/16"
	Maximum Throat Depth: 12 3/4"	0.32m	12 3/4"

Power Unit:

	D55	E25	E30
Manufacturer:	Yanmar	Lincoln	Lincoln
Fuel:	Diesel	Electric	Electric
Horsepower Rating*:	55.5	25	30
Weight (lbs)*:	395		
Cooling System*:	water	air	air
Noise Level (dba)*:	72		
Fuel Consumption(gallon/hour)*:	1		
Engine Oil & Type*:			
Engine Oil Capacity w/Filter*:			
Temperature Range & Oil Grades*:			
Coolant Capacity*:			

Rates:

Max. Forward (Not Cutting): 190 ft/min
Reverse: 200 ft/min
Hourly Production (Average range w/experienced operators/average size logs): 940 bd ft/hr

*Manufacturer's Specification

Model: LT70HD Rev. A5.00 - B4.06

Dimensions:

Length: 26'-2"
Width: 6'-3"
Height (Ground To Mast): 7'-5 1/2"
Height (Max Head Position): 12'-0"
Bed Height (Ground To Bed): 29"
Blade Length: 184"

Weights:	D51	D62	D42	E25	D55
Basic Unit (Wet):	4165 lbs	4620 lbs	4115 lbs	3986 lbs	4076 lbs
w/Trailer:	4590 lbs	5045 lbs	4540 lbs	4411 lbs	4501 lbs
Tongue Weight:			157 lbs		

Trailer:

Axle Capacity: 5080 lbs
Tire Capacity: 2540 lbs
Tire Size: ST225/75R15
Weight: 425 lbs

Log Capacity:

Length: 20'-2"
Diameter: 36"
Weight: 4400 lbs.
Max Clamp Width (from stop block): 26"
Max Throat Width (guide to guide): 29"
Max Cant Width (outer guide to stop block): 25 1/2"

Engine:	D51	D62	D42	E25	D55
Manufacturer:	Caterpillar	Caterpillar	Kubota	Lincoln	Yanmar
Fuel:	Diesel	Diesel	Diesel	Electric	Diesel
Horsepower Rating:	51	62	42	25	55.2
Weight:	485 lbs	525 lbs	435 lbs	263 lbs	396 lbs
Idle Speed:	1500 RPM	1500 RPM	1500 RPM	3500 RPM	1500 RPM
High Throttle Speed (No Load):	3100 RPM	2950 RPM	3200 RPM	3500 RPM	2800 RPM
Noise Level - @ operator position:	92 dBA	92 dBA	98 dBA	75 dBA	72 dBA
Noise Level - 20 feet away:	84 dBA	84 dBA	87 dBA		
Noise Level - 200 feet away:		70 dBA		63 dBA	
Blade Speed (No Load):	sfp	5620 sfp	sfp	6114 sfp	
Fuel Consumption (per hour):	1.5 gal	1.5 gal.	1 gal.	20 KwHr	
Cooling System:	Water	Water	Water	N/A	Water
Drive Shaft O.D.:	1 7/16"	1 7/16"	1 7/16"	1 5/8"	1 7/16"
Drive Pulley O.D.:	5.5"	5.5"	5.5"	5"	5.5"
Drive Belt:	3/5VX950	3/5VX950	3/5VX950	3/5VX950	3/5VFX950
Blade Braking:	6-7 Seconds	6-7 Seconds	6-7 Seconds	6-7 Seconds	6-7 Seconds
Oil Capacity w/Filter:	10 qts.	10.6 qts.	6.7 qts.	N/A	7.8 qts.
Battery:	12V 1100CCA	12V 1100CCA	12V 1100CCA	N/A	12V 1100CCA
Alternator Output:	190 Amps	190 Amps	190 Amps	N/A	190 Amps
Alternator Belt:	6PK415	6PK415	6PK400	N/A	6PK1145

Rates:	D51	D62	D42	E25	D55
Max. Forward (Not Cutting):	205 ft./min.	182 ft./min.		208 ft./min.	
Reverse:	200 ft./min.	186 ft./min.		206 ft./min.	
Hourly Production (Average range w/experienced operators/average size logs):	up to 850 bdf.				
Saw Head Up (24"):	6.72 sec.	11.68 sec.	8.71 sec.	8.94 sec.	
Saw Head Down (24"):	5.63 sec.	7 sec.	5.36 sec.	7.57 sec.	

Options:

Single/Lap Siding Option: 143 lbs.
Debarker: lbs.
Laser Sight: lbs.
6' Bed Extension: 390 lbs.
12' Bed Extension: 758 lbs.
24' Bed Extension: 1122 lbs.
Accuset: 13 lbs
Operator Seat: 112 lbs.
Resaw Attachment (DC only): 231 lbs.
±1/32" per drop

Electrical Requirements (E25):	E25-L			E25-H				E25-C
Voltage (3Ph 50/60Hz ±5%):	208	220	230	380	415	440	460	575
Fuse Disconnect - Saw Control:	100 Amp	100 Amp	100 Amp	60 Amp	60 Amp	60 Amp	60 Amp	60 Amp
Time Delay Fuse - Saw Control:	100 Amp	100 Amp	100 Amp	60 Amp	50 Amp	50 Amp	50 Amp	40 Amp
Suggested Wire Size - Saw Control (50' max.):	3AWG	3AWG	3AWG	6AWG	6AWG	6AWG	6AWG	6AWG
Fuse Disconnect - Hydraulic Control:	30 Amp	30 Amp	30 Amp	30 Amp	30 Amp	30 Amp	30 Amp	30 Amp
Time Delay Fuse - Hydraulic Control:	16 Amp	16 Amp	16 Amp	8 Amp	8 Amp	8 Amp	8 Amp	8 Amp
Suggested Wire Size - Hydraulic Control (50' max.):	12AWG	12AWG	12AWG	14AWG	14AWG	14AWG	14AWG	14AWG

RotoPhase Option (converts 1Ph to 3Ph):

Voltage (1Ph 50/60Hz): 230
Main Disconnect: 200 Amp
Fused Disconnect: 200 Amp
Time Delay Fuse: 125 Amp
Output: 100 Amp
Wire Size: 1/0AWG+

1 Introduction

Customer and Sawmill Identification

1.4 Customer and Sawmill Identification

Each Wood-Mizer sawmill has a model number and a 17-digit Vehicle Identification Number (VIN). In addition, when you pick up your mill, you will receive a customer number. These three numbers will help expedite our service to you. Please locate them now and write them below so you have quick, easy access to them. See the following figures for model number and V.I.N. descriptions.

(To be filled in by purchaser)

Mill Model _____
 Mill VIN _____
 Customer No _____

See below for a description of the V.I.N.

Basic model Engine Voltage Configuration Revision number Minor revision level

LT70HD D51 -H **A1.01**

VIN Plate Serial number Full revision number

MFG BY/FABRIQUÉ PAR: WOOD-MIZER, LLC 8180 W. 10th St. Indianapolis, IN
 46214-2400 U.S.A. 317/271-1542 Or 800/553-0182

VIN/NIV: 456D9271XSND A1017	A1.01	DATE: 04/15/2017
GVWR/PNBV: GAWR/PNBE: TIRE SIZE/PNEU: RIM /JANTE: COLD INFL. PRESSURE/ PRESS. DE GONF. À FROID:	VEHICLE TYPE/TYPE DE VÉHICULE: TRAILER/REMORQUE THIS VEHICLE CONFORMS TO ALL APPLICABLE FEDERAL MOTOR SAFETY STANDARDS AND THOSE PRESCRIBED UNDER THE CANADIAN VEHICLE SAFETY REGULATIONS IN EFFECT ON THE DATE OF MANUFACTURE. CE VÉHICULE EST CONFORME À TOUTES LES NORMES QUI LUI SONT APPLICABLES EN VERTU DU REGLEMENT SUR LA SÉCURITÉ DES VÉHICULES AUTOMOBILES DU CANADA EN VIGUEUR À LA DATE DE SA FABRICATION.	

One or more patents may apply: U.S. Patent #6,655,429

Sample VIN	Company Identification Number	Weight Class	Product Designation number	Length of the Trailer	Axle count	Check Digit	Year of Manufacture (coded)	Manufacture location	Month of Manufacture	Revision Level	Sequence Number
	456	D	9	27	1	X	S	N	D	A1	017

V.I.N. DESCRIPTION

1.5 Warranty

Wood-Mizer® LLC
Limited Product Warranty

Wood-Mizer®

Wood-Mizer LLC (“Warrantor”), an Indiana corporation with its principal place of business at 8180 West Tenth Street, Indianapolis, IN 46214-2400 USA, warrants to the purchaser (“Purchaser”) that for the time periods specifically stated herein and subject to the terms, conditions and limitations stated herein, the equipment manufactured by the Warrantor will be free from defects in material and workmanship attributable to Warrantor so long as, during the warranty periods stated herein, the equipment is installed, operated and maintained in accordance with the instructions provided by Warrantor.

PRODUCT	MODEL CLASS	LENGTH OF WARRANTY		EFFECTIVE DATE
		USA & CANADA	NON USA & CANADA	
Portable Sawmills, Resaws, Edgers	LT, LX, HR, EG	Two years	One year	Date of purchase
Portable Sawmills with Chassis	LT28, LT35, LT40, LT50, LT70, LX450	Two years, excluding the chassis, which chassis shall have a five year warranty	One year	
Industrial Sawmills, Resaws, Edgers	WM, HR, EG, TVS, SVS, FS	One year	One year	Date of purchase or date of installation / training (if applicable), whichever occurs first, not to exceed 6 months from date of purchase
TITAN Industrial	WB, TV, HR, EG, EA, MR	One year	One year	
Material Handling	TWC, IC, TD, LD, GC, CR, CB, CC	One year	One year	
Blade Maintenance Equipment	BMS, BMT, BMST	One year	One year	Date of purchase
Options and Accessories	Various	One year ¹	One year ¹	
Moulders, Kilns	MP, SD, KD	One year	One year	
Pallet Dismantler	PD	One year	One year	
Log Splitter	FS	One year	One year	
Replacement Parts	Various	90 days	90 days	

¹ Warranty on Options will match the warranty on the primary equipment when purchased on same invoice.

EXCLUSIONS FROM 90 DAY, LIMITED ONE YEAR AND TWO YEAR WARRANTY

Warrantor shall have **no** responsibility under this warranty for any wear components, including, but not limited to: belts, blade guides, blades, electric motor brushes, drum switches, filters, fuses, hoses, bearings (excluding cylindrical drive bearings), bushings, cable carriers, and spark plugs. All wear components are furnished **“as is”**, without any warranty from Warrantor. This limited warranty does not cover any defects caused by

misuse, negligence, alterations, damage due to overload, abnormal conditions, excessive operation, accident, or lack of performance of normal maintenance services.

Several components which are used in the manufacture of the equipment but not manufactured by Warrantor, such as cant hooks, power plants, laser sights, batteries, tires, and trailer axles have warranties provided by the original equipment manufacturer (written copies available upon request). Warrantor does not separately warrant such items. Components or equipment manufactured by third parties are not covered by this warranty. Warrantor, however, will provide reasonable assistance to the Purchaser to make claims against any warranties applicable to such component parts as provided by such original equipment manufacturers. Components or equipment manufactured by third parties are not covered by this Warranty.

FIVE YEAR LIMITED CHASSIS WARRANTY

The limited five year chassis warranty, described above, DOES NOT extend to (a) any damage stemming from accident, improper towing, overload, abuse, misuse, abnormal conditions, negligence, excessive operation, or lack of maintenance, (b) rust caused by exposure to corrosive atmospheric conditions, or (c) the sawmill head, carriage, axle, brakes, or any hydraulic or electrical components attached to the chassis.

WARRANTOR'S OBLIGATIONS AS TO DEFECTS

In the event that the equipment fails to perform due to defective materials or workmanship attributable to Warrantor under normal use and service within the established warranty period, Purchaser's sole and exclusive remedy and Warrantor's sole liability shall be to replace or repair, in Warrantor's sole and subjective discretion, any defective part at Warrantor's principal place of business without cost to the Purchaser if such defect exists. The determination of whether a product is defective shall be made by Warrantor in Warrantor's sole and subjective discretion. The Purchaser must notify Warrantor prior to shipping any defective part. Warrantor, at its sole discretion, may cover expenses incurred in shipping the defective part to Warrantor for evaluation; provided, however, that Warrantor will not be responsible for labor, travel time, mileage, removal, installation, and/or incidental or consequential damages. However, any part in excess of 140 pounds must be returned by the Purchaser to the Warrantor's nearest authorized facility at the Purchaser's expense, if return is requested by Warrantor. Warrantor shall have a reasonable time within which to repair or replace the defective part. If Warrantor determines that the product is not defective under the terms of this warranty in Warrantor's sole and subjective discretion, then Purchaser shall be responsible for any expenses incurred by Warrantor in returning the equipment to the Purchaser.

LIMITATIONS AND DISCLAIMERS OF OTHER WARRANTIES

EXCEPT FOR THE EXPRESS WARRANTY PROVISIONS STATED ABOVE, WARRANTOR DISCLAIMS ALL WARRANTIES, EXPRESS AND/OR IMPLIED, INCLUDING AND WITHOUT LIMITATION, THE IMPLIED WARRANTIES OF MERCHANTABILITY, AND FITNESS FOR A PARTICULAR PURPOSE, NONINFRINGEMENT AND TITLE. No representation or other affirmation of fact by representatives of Warrantor, whether verbal or in writing, including photographs, brochures, samples, models, or other sales aids, shall constitute a warranty, or any other basis, for any legal action against Warrantor. There are no other representations, promises, agreements, covenants, warranties, guarantees, stipulations or conditions, expressed or implied, by Warrantor, except as expressly set forth herein. THE PURCHASER AND ANY INTENDED USER OR BENEFICIARY OF THIS EQUIPMENT, SHALL NOT BE ENTITLED TO RECOVER ANY INDIRECT, SPECIAL, PUNITIVE, EXEMPLARY, CONSEQUENTIAL, SPECIAL, OR INCIDENTAL DAMAGES OR LOSSES, INCLUDING BUT NOT LIMITED TO, DAMAGES OF LOST PRODUCTION, LOST REVENUE, LOST PRODUCT, LOST PROFITS, LOST BUSINESS, LOSS OF USE, LOSS OF GOODWILL, OR BUSINESS INTERRUPTION, FROM WARRANTOR FOR ANY REASON WHATSOEVER INCLUDING, WITHOUT LIMITATION, WARRANTY OR DEFECT IN THE PRODUCT REGARDLESS OF THE SOLE, JOINT, AND/OR CONCURRENT NEGLIGENCE, BREACH OF CONTRACT, BREACH OF WARRANTY, STRICT LIABILITY IN TORT OR STATUTORY CLAIMS, OR OTHER LEGAL FAULT, OR RESPONSIBILITY OF EITHER WARRANTOR OR PURCHASER OR ITS EMPLOYEES OR AGENTS. Warrantor does not warrant that its equipment meets or complies with the requirements of any particular safety code or governmental requirements.

Defective items, replaced under the terms of this warranty, become the property of Warrantor.

DESIGN CHANGES

Warrantor reserves the right to change the design of its products from time to time without notice and without obligation to make corresponding changes in or to its products previously manufactured.

RIGHTS OF PURCHASERS

The validity and effect of this limited warranty, as well as its interpretation, operation and effect, shall be determined exclusively by the principles of law and equity of the State of Indiana, USA. This limited warranty gives Purchaser specific legal rights. Purchaser may also have other rights, which may vary from state to state. Some states may not allow limitations as to the duration of implied warranties or to the exclusion or limitation of incidental or consequential damages, therefore some of the limitations and exclusions detailed set forth above may not apply. In the event that any one or more of the provisions of this warranty shall be or become invalid, illegal or unenforceable in any respect, the validity, legality and enforceability of the remaining provisions of this warranty shall not be affected thereby.

INTERPRETATIONS

This Warranty constitutes the entire warranty agreement between Warrantor and Purchaser and supersedes any prior understandings or agreements pertaining to the same subject matter. This warranty cannot be amended, except in writing, which refers to this warranty that is signed by both Warrantor and Purchaser.

© 2018 Wood-Mizer LLC – 8180 West 10th Street, Indianapolis, IN 46214

SECTION 2 SAFETY

2.1 Safety Symbols

The following symbols and signal words call your attention to instructions concerning your personal safety. Be sure to observe and follow these instructions.



DANGER! indicates an imminently hazardous situation which, if not avoided, will result in death or serious injury.



WARNING! suggests a potentially hazardous situation which, if not avoided, could result in death or serious injury.



CAUTION! refers to potentially hazardous situations which, if not avoided, may result in minor or moderate injury or damage to equipment.



IMPORTANT! indicates vital information.

NOTE: gives helpful information.

2.2 Safety Instructions

OWNER'S RESPONSIBILITY

The procedures listed in this manual may not include all ANSI, OSHA, or locally required safety procedures. It is the owner/operator's responsibility and not Wood-Mizer Products to ensure all operators are properly trained and informed of all safety protocols. Owner/Operators are responsible for following all safety procedures when operating and performing maintenance to the sawmill.

NOTE: ONLY safety instructions regarding personal injury are listed in this section. Caution statements regarding only equipment damage appear where applicable throughout the manual.



WARNING! Clean sawdust from all guards, vents, control boxes, or any area where sawdust may gather **after every shift**. Failure to do so may result in fire, causing death or serious injury.



OBSERVE SAFETY INSTRUCTIONS



IMPORTANT! Read the entire Operator's Manual before operating the sawmill. Take notice of all safety warnings throughout this manual and those posted on the machine. Keep this manual with this machine at all times, regardless of ownership.

Also read any additional manufacturer's manuals and observe any applicable safety instructions including dangers, warnings, and cautions.

Only persons who have read and understood the entire operator's manual should operate the sawmill. The sawmill is not intended for use by or around children.



IMPORTANT! It is always the owner's responsibility to comply with all applicable federal, state and local laws, rules and regulations regarding the ownership, operation and towing of your Wood-Mizer sawmill. All Wood-Mizer mill owners are encouraged to become thoroughly familiar with these applicable laws and comply with them fully while using or towing the mill.



WEAR SAFETY CLOTHING

 **WARNING!** Secure all loose clothing and jewelry before operating the sawmill. Failure to follow this may result in serious injury or death.

 **WARNING!** Always wear gloves and eye protection when handling bandsaw blades. Changing blades is safest when done by one person! Keep all other persons away from area when coiling, carrying or changing a blade. Failure to follow this may result in serious injury or death.

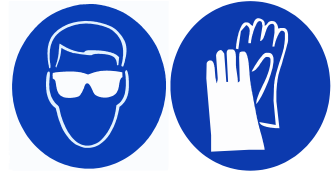

 **WARNING!** Always wear eye, ear, and foot protection when operating or servicing the sawmill.





 **WARNING!** Some woods require respiration protection when operating the sawmill. It is the sawyer's responsibility to know which woods require respiration protection.

KEEP SAWMILL AND AREA AROUND SAWMILL CLEAN

 **DANGER!** Maintain a clean and clear path for all necessary movement around the mill and lumber stacking areas. Failure to follow this will result in serious injury or death.

HANDLE FUEL/LUBRICANTS SAFELY

 **DANGER!** Do not smoke, weld, grind or allow sparks near your engine or storage tanks, especially during times of fueling. Failure to follow this will result in serious injury or death.

 **DANGER!** Never allow fuel to spill on a hot engine during fueling operations or otherwise. The hot temperature of your engine could induce a fire or explosion. Failure to follow this will result in serious injury or death.

 **WARNING!** Store gasoline away from sawdust and other flammable materials. Failure to follow this may result in serious injury or death.

 **WARNING!** Use ONLY water and Wood-Mizer Lube Additive with the water lube accessory. Never use flammable fuels or liquids such as diesel fuel. If these types of liquids are necessary to clean the blade, remove it and clean with a rag. Failure to follow this could result in serious injury or death.





WARNING! Drum switch grease contains Petroleum Hydrocarbon Lubricant. Eye and skin irritant. If introduced into eyes, flush with water for at least 15 minutes. If film or irritation persists, seek medical attention. Wash skin with soap and water. If ingested, do not induce vomiting - contact a physician. KEEP OUT OF THE REACH OF CHILDREN.

DISPOSE OF SAWING BY-PRODUCTS PROPERLY



IMPORTANT! Always properly dispose of all sawing by-products, including sawdust and other debris, coolant, oil, fuel, oil filters and fuel filters.

USE CAUTION WHEN WORKING WITH BATTERIES (ENGINES ONLY)



DANGER! Batteries expel explosive gases; keep sparks, flames, burning cigarettes, or other ignition sources away at all times. Failure to follow this will result in serious injury or death.



WARNING! Always wear safety goggles and a face shield when working near batteries. Failure to follow this could result in serious injury or death.



WARNING! Wash hands after handling batteries to remove possible lead, acid, or other contaminants. Failure to follow this could result in serious injury or death.



WARNING! Charge the battery in a well ventilated area. Failure to follow this could result in serious injury or death.



WARNING! Do not attempt to charge a frozen battery. Failure to follow this could result in serious injury or death.



IMPORTANT! When working with batteries, use extreme care to avoid spilling or splashing electrolyte (dilute sulfuric acid) as it can destroy clothing and burn the skin.

EMERGENCY TREATMENT FOR CONTACT WITH BATTERY COMPONENTS (LEAD/SULFURIC ACID) per SDS (Safety Data Sheet):

EYE CONTACT	Sulfuric Acid and Lead: Flush eyes immediately with large amounts of water for at least 15 minutes while lifting lids. Seek immediate medical attention if eyes have been exposed directly to acid.
SKIN CONTACT	Sulfuric Acid: Flush affected area(s) with large amounts of water using deluge emergency shower, if available, shower for at least 15 minutes. Remove contaminated clothing, including shoes. If symptoms persist, seek medical attention. Wash contaminated clothing before reuse. Discard contaminated shoes. Lead: Wash immediately with soap and water.
INGESTION	Sulfuric Acid: Administer large amounts of water. Do NOT induce vomiting or aspiration into the lungs may occur and can cause permanent injury or death; consult physician.
INHALATION	Sulfuric Acid: Remove to fresh air immediately. If not breathing, give artificial respiration. If breathing is difficult, give oxygen. Consult a physician. Lead: Remove from exposure, gargle, wash nose and lips; consult physician.

 **CAUTION!** Do not overcharge the battery. Overcharging could reduce the overall service life of the battery.

 **CAUTION!** Be sure the battery is fully charged before transporting the sawmill. If the battery is not fully charged, excessive vibration could reduce the overall service life of the battery.

CAUTIONS FOR SAWMILL SETUP

 **WARNING!** Do not set up the mill on ground with more than a 10 degree incline. Failure to follow this could result in serious injury or death.

If setup on an incline is necessary, put blocks under one side of the mill or dig out areas for the outrigger legs to keep mill level. Setting up the mill on an incline could cause it to tip over.

 **WARNING!** Chock the trailer wheels to prevent movement before unhitching it from the towing vehicle. Failure to follow this could result in serious injury or death.

 **WARNING!** Put front outrigger down before moving saw head from the rest position. Failure to follow this could result in serious injury or death.

 **WARNING!** Always make sure the trailer is supporting the sawmill frame when operating a sawmill with adjustable outriggers. Failure to follow this could result in serious injury or death. The adjustable outrig-

gers are intended to support the saw frame with assistance from the trailer.



WARNING! The adjustable outriggers supplied with portable sawmills are not intended for setup on concrete or other hard surfaces. Long-term use of the adjustable outriggers on hard surfaces could cause the outriggers to fail. If setting the sawmill up on concrete or other hard surface, replace the adjustable outrigger legs with stationary legs. Failure to follow this could result in serious injury or death.



WARNING! Securely fasten the feet of a stationary sawmill to the floor before operating the sawmill. Failure to follow this could result in serious injury or death.

CHECK SAWMILL/BLADES BEFORE OPERATION



DANGER! Ensure the blade housing and pulley covers are in place and secure. Failure to follow this could result in serious injury or death.



DANGER! Ensure all guards and covers are in place and secured before operating or towing the sawmill. Failure to follow this could result in serious injury or death.



DANGER! Do not use blades with stress cracks. Failure to follow this could result in serious injury or death.

Blade guide alignment is essential for optimal cutting performance, blade life and safety. Failure to check and maintain proper blade guide alignment will result in stress cracks forming in the blade. These cracks will lead to premature blade breakage. If the blade breaks during operation and the blade has multiple stress cracks, the blade could shatter into several pieces and escape from the protective guards of the sawmill. Small blade pieces projected into the area around the sawmill creates a safety hazard for the operator and any bystanders surrounding the mill.

KEEP PERSONS AWAY



DANGER! Stay clear of the area between the trailer axle and saw carriage. Failure to follow this will result in serious injury or death.



DANGER! Keep all persons out of the path of moving equipment and logs when operating sawmill or loading and turning logs. Failure to follow this will result in serious injury or death.





DANGER! Always be sure the blade is disengaged and all persons are out of the path of the blade before starting the engine or motor. Failure to follow this will result in serious injury or death.



KEEP HANDS AWAY



DANGER! Always disengage the blade and shut off the sawmill engine before changing the blade. Failure to follow this will result in serious injury or death.



DANGER! Engine components can become very hot during operation. Avoid contact with any part of a hot engine. The exhaust components of your engine are especially hot during and following operation. Contact with hot engine components can cause serious burns. Therefore, never touch or perform service functions on a hot engine. Allow the engine to cool sufficiently before beginning any service function.



DANGER! Always keep hands away from moving bandsaw blade. Failure to follow this will result in serious injury or death.



DANGER! Always be aware of and take proper protective measures against rotating shafts, pulleys, fans, etc. Always stay a safe distance from rotating members and make sure that loose clothing or long hair does not engage rotating members resulting in serious injury or death.



WARNING! Do not spin the blade wheels by hand. Spinning the blade wheels by hand could result in serious injury or death.



WARNING! Always disengage the clutch/brake mechanism whenever the sawmill is not cutting. Failure to follow this could result in serious injury or death.





WARNING! Do not for any reason adjust the engine drive belts or belt support bracket with the engine running. Doing so could result in serious injury or death.



WARNING! Always keep clear of exiting sawdust. Keep hands, feet and any other objects away from the sawdust chute when operating sawmill. Failure to follow this could result in serious injury or death.

CAUTIONS FOR GAS OR DIESEL ENGINE OPERATION

 **DANGER!** Operate your engine/machine only in well ventilated areas. The exhaust gases of your engine can cause nausea, delirium and potentially death unless adequate ventilation is present.

 **DANGER!** Never operate an engine with a fuel or oil leak. The leaking fuel or oil could potentially come in contact with hot surfaces and ignite into flames.

 **WARNING!** Do not operate engine without proper and operational spark arrester/muffler. Sparks emitted from the engine exhaust could ignite surrounding materials, causing serious injury or death.

KEEP SAFETY LABELS IN GOOD CONDITION

 **IMPORTANT!** Inspect all safety decals to ensure they are clean and readable. Replace all damaged safety decals to prevent personal injury or damage to the equipment. Contact your local distributor, or call your Customer Service Representative to order more decals.

 **IMPORTANT!** If replacing a component which has a safety decal affixed to it, make sure the new component also has the safety decal affixed.

USE CAUTION WHEN WORKING WITH HEAVY LOGS

 **WARNING!** Always make sure log is clamped securely before sawing. Failure to follow this could result in serious injury or death.

 **WARNING!** Always leave hydraulic loading arm halfway up while log is on sawmill bed. Failure to follow this could result in serious injury or death.

AUTOMATIC BOARD RETURN SAFETY

 **DANGER!** Keep all persons out of the path of returning boards. Failure to follow this will result in serious injury or death.

 **WARNING!** The automatic board return is intended to assist a second operator in removing boards quickly. Do not use the board return when operating the sawmill alone. Serious injury, death or damage to the equipment could result.

 **WARNING!** Never use the board return table as a platform to stand on. This table is designed and intended to assist in the removal of boards only. Standing on the table could result in serious injury or death.

UP/DOWN SYSTEM SAFETY

 **WARNING!** Always secure the saw head with a 5/16" chain with at least 1900 lbs. working load capacity before adjusting the up/down chain. The saw head could fall, causing severe injury or death.

 **WARNING!** Always secure the saw head with a 5/16" chain with approximately 1900 lbs. working load capacity before removing the up/down motor belt. The saw head could fall, causing severe injury or death.

 **WARNING!** Always secure the saw head with a 5/16" chain with at least 1900 lbs. working load capacity before servicing the up/down assist (Rev. A5.00+). The cutting head could fall, causing severe injury or death.

 **WARNING!** Release pressure from the up/down assist prior to performing any service to the assembly (Rev. A5.00+). Failure to follow this could result in the assembly flying apart, causing serious injury or death.

 **WARNING!** The gas spring cylinders are pressurized (Rev. A5.00+). Disassembly of cylinder may result in serious injury or death.

POWER FEED SYSTEM SAFETY

 **DANGER!** If leaving the blade engaged for maximum production rates, make sure the off-bearer stays out of the path of the blade. Failure to follow this will result in serious injury or death.

 **WARNING!** Be sure the power feed switch is in the neutral position before turning the key switch to the on (#1) or accessory (#3) position. This prevents accidental carriage movement which may cause serious injury or death.

GENERAL TRAILER SAFETY

 **DANGER!** Make sure your hitch has adequate safety chain hookups. Do not use eyebolts for safety chain hook-up. Safety chains should be hooked to bumper of vehicle so that each chain would pull the trailer equally in the event the hitch became disengaged. Failure to follow this will result in serious personal injury and/or severe machine damage.



DANGER! Be sure that the hitch and safety chains are secure before towing the sawmill. Failure to follow this will result in serious personal injury and/or severe machine damage.



DANGER! Make sure all light connections have been made and are working properly before towing the sawmill. Failure to follow this will result in serious personal injury and/or severe machine damage.



WARNING! The trailer option is designed for the express purpose of towing the sawmill it is supplied with. Do not make modifications or additions that affect the weight and/or stability of the towing unit. Doing so could result in property damage and/or serious injury or death.



WARNING! Always check trailer tires for proper inflation before towing sawmill. Failure to follow this could lead to tire failure resulting in property damage and/or serious injury or death.



CAUTION! Move the hydraulic clamp and turner to provide maximum ground clearance before towing. Failure to follow this could result in damage to the sawmill.

ADDITIONAL SAFETY FOR ELECTRIC BRAKE TRAILERS



DANGER! Make sure the electric brake wire is secured as close to the trailer axle as possible to prevent wire disconnection during towing. Failure to follow this will result in serious personal injury or death.



DANGER! Be sure electric brake battery is charged and is working properly before towing the sawmill. Failure to follow this will result in serious personal injury or death.



DANGER! Do not use the electric brake system as an “emergency brake” while the sawmill is not being towed. Extended use of the electric brakes while the sawmill is stationary will drain the brake battery.

DEBARKER ACCESSORY SAFETY





DANGER! Make sure all guards and covers are in place and secured before operating the debarker option. Failure to follow this will result in serious injury or death.



DANGER! Keep all persons out of the path of moving equipment when operating the debarker. Failure to follow this will result in serious injury or death.

 **DANGER!** Always remove the key from the control panel before preparing the debarker for towing. Failure to follow this will result in serious injury or death.

 **WARNING!** Before replacing the debarker blade, move the sawmill blade guide arm in front of the sawmill blade to cover the blade teeth. Failure to follow this could result in serious injury or death.

 **WARNING!** Debarker is ON when warning light is on. DO NOT disconnect the warning light. Doing so could result in serious injury or death.

 **WARNING!** If the debarker continues to run with the key switch in the OFF position, remove the negative battery terminal from the battery post.

DO NOT continue to operate the mill if the main key switch does not control debarker operation. Doing so could result in serious injury or death. Call Wood-Mizer customer service for more information.

USE PROPER PROCEDURE WHEN CONDUCTING ELECTRICAL SAFETY CHECKS AND MAINTENANCE

 **DANGER!** Make sure all electrical installation, service and/or maintenance work is performed by a qualified electrician and is in accordance with applicable electrical codes.

 **DANGER!** ARC FLASH AND SHOCK HAZARD! Hazardous voltage inside the electric sawmill disconnect box, starter box, and at the motor can cause shock, burns, or death. Disconnect and lock out power supply before servicing! Keep all electrical component covers closed and securely fastened during mill operation. Wear appropriate Personal Protection Equipment.





 **DANGER!** Hazardous voltage enters machine at two locations. Power enters machine at motor starter box and hydraulic control box. Disconnect and lock out both power supplies before servicing! Failure to follow this will result in shock, burns, or death.

 **WARNING!** Consider all electrical circuits energized and dangerous. Failure to follow this could result in shock, burns, or death.

 **WARNING!** Disconnect the negative battery terminal cable before performing any service to the 12-Volt electrical system. Failure to follow this could result in injury and/or electrical system damage.

 **WARNING!** Never assume or take the word of another person that the power is off; check it out and lock it out. Failure to follow this could result in shock, burns, or death.

 **WARNING!** Do not wear rings, watches, or other jewelry while working around an open electrical circuit. Failure to follow this could result in shock, burns, or death.

 **WARNING!** Before performing service near moving parts such as blades, pulleys, motors, belts and chains, first turn the key switch to the OFF (#0) position and remove the key. If the key is turned on and moving parts activated, serious injury or death could result.

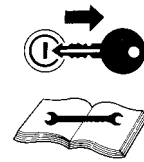

 **WARNING!** Remove the blade before performing any service to the engine or sawmill. Failure to follow this could result in serious injury or death.

2.3 Electrical Lockout Procedures

RULES FOR USING LOCKOUT PROCEDURE

The sawmill shall be locked out to protect against accidental or inadvertent operation when such operation could cause injury to personnel. Do not attempt to operate any switch or valve bearing a lock.

LOCKOUT PROCEDURES MUST BE USED DURING:

Cleaning	Electrical maintenance
Mechanical repair	Retrieval of tools/parts from work area
Unjamming operations	Activities where guards or electrical panel guard is open or removed
Changing or adjusting blades	

MAINTENANCE HAZARDS INCLUDE:

Kickbacks	Electrical
Pinch points	Missiles (thrown blades/wood chips)
Blade contact	

FAILURE TO LOCKOUT MAY RESULT IN:

Cut	Burn
Crush	Shock
Puncture	Amputation
Blindness	Serious injury and death
Electrocution	

TO CONTROL MAINTENANCE DANGERS:

- Lockout procedures must be followed (see OSHA regulation 1910.147).
- Never rely on machine stop control for maintenance safety (emergency stops, on/off buttons, interlocks).
- Do not reach into moving blades or feed systems. Allow all coasting parts to come to a complete stop.
- Electrical power supply and air supply must both be locked out.
- Where established lockout procedures cannot be used (electrical troubleshooting or mechanical dynamic troubleshooting), alternative effective protective techniques shall be employed which may require special skills and planning.
- Always follow safe operations practices in the workplace.

SAWMILL LOCKOUT PROCEDURE

Lockout procedures per OSHA regulation 1910.147, appendix A:

GENERAL

The following simple lockout procedure is provided to assist owner/operators in developing their procedures so they meet the requirements of OSHA regulation 1910.147. When the energy isolating devices are not lockable, tagout may be used, provided the owner/operator complies with the provisions of the standard which require additional training and more rigorous periodic inspections. When tagout is used and the energy isolating devices are lockable, the owner/operator must provide full operator protection (see OSHA regulation 1910.147, paragraph (c)(3)) and additional training and more rigorous periodic inspections are required. For more complex systems, more comprehensive procedures may need to be developed, documented, and utilized.

PURPOSE

This procedure establishes the minimum requirements for the lockout of energy isolating devices whenever maintenance or servicing is done on machines or equipment. It shall be used to ensure that the machine or equipment is stopped, isolated from all potentially hazardous energy sources and locked out before personnel perform any servicing or maintenance where the unexpected energization or start-up of the machine or equipment or release of stored energy could cause injury.

COMPLIANCE WITH THIS PROGRAM

All personnel are required to comply with the restrictions and limitations imposed upon them during the use of lockout. The authorized personnel are required to perform the lockout in accordance with this procedure. All operators, upon observing a machine or piece of equipment which is locked out to perform servicing or maintenance shall not attempt to start, energize, or use that machine or equipment.

SEQUENCE OF LOCKOUT

1. Notify all affected personnel that servicing or maintenance is required on a machine or equipment and that the machine or equipment must be shut down and locked out to perform the servicing or maintenance.
2. The authorized employee shall refer to the company procedure to identify the type and magnitude of the energy that the machine or equipment utilizes, shall understand the hazards of the energy, and shall know the methods to control the energy.
3. If the machine or equipment is operating, shut it down by the normal stopping procedure (depress the stop button, open switch, close valve, etc.).
4. De-activate the energy isolating device(s) so that the machine or equipment is isolated from the energy source(s).
5. Lock out the energy isolating device(s) with assigned individual lock(s).
6. Stored or residual energy (such as that in capacitors, springs, elevated machine members, rotating flywheels, hydraulic systems, and air, gas, steam, or water pressure, etc.) must be dissipated or restrained by methods such as grounding, repositioning, blocking, bleeding down, etc.
7. Ensure that the equipment is disconnected from the energy source(s) by first checking that no personnel are exposed, then verify the isolation of the equipment by operating the push button or other normal operating control(s) or by testing to make certain the equipment will not operate.



CAUTION! Return operating control(s) to neutral or "off" position after verifying the isolation of the equipment.

8. The machine or equipment is now locked out.

RESTORING EQUIPMENT TO SERVICE

When the servicing or maintenance is completed and the machine or equipment is ready to return to normal operating condition, the following steps shall be taken.

1. Check the machine or equipment and the immediate area around the machine to ensure that nonessential items have been removed and that the machine or equipment components are operationally intact.
2. Check the work area to ensure that all personnel have been safely positioned or removed from the area.
3. Verify that the controls are in neutral.
4. Remove the lockout devices and re-energize the machine or equipment.

NOTE: The removal of some forms of blocking may require re-energization of the machine before safe removal.

5. Notify affected personnel that the servicing or maintenance is completed and the machine or equipment is ready for use.



IMPORTANT! In the preceding steps, if more than one individual is required to lock out the sawmill, **each shall place his own personal lock on the energy isolating devices.**

SECTION 3 SAWMILL SETUP

3.1 Stationary Sawmill Setup

Prepare the site:

- Area must be firm and level.
- The cement pad should be rated to support 6350 lbs./sq.ft.
- Use 5/8" diameter anchor bolts to secure feet.
- Allow maneuvering room for operators, sawdust removal, log loading, and board removal.

[See Form #847](#) for stationary sawmill foot anchor locations. [See Form #359](#) for stationary sawmill with bed extension foot anchor locations. [See Form #1084](#) for complete electric sawmill installation instructions.

NOTE: Make sure the unit is level before securing. It **IS POSSIBLE** to twist the mill frame by jacking one foot higher than the others.



WARNING! Securely fasten the feet of a stationary sawmill to the floor before operating the sawmill. Failure to do so may result in serious injury or death.

1. Unhook the carriage safety chain, located at the bottom of the vertical mast.
2. Release the fender straps and lift up to remove the fenders. Stow until needed for transport..Start the engine to enable the battery-operated accessories ([See Section 3.6](#)). Use the up/down switch on the control panel to raise the cutting head from the carriage rest pin.
3. Remove the locking pin and swing the rest pin down below bed level.

NOTE: DC Models Only: Always make sure the engine is running before operating the sawmill controls. Operating the controls without the engine running will result in power drainage from the battery.

4. Use the carriage forward/reverse switch (left side of control box) to move the cutting head toward the front (hitch end) of the mill.
5. Raise the side supports to prevent a log from falling off the side of the mill when loaded.

See Figure 3-1.

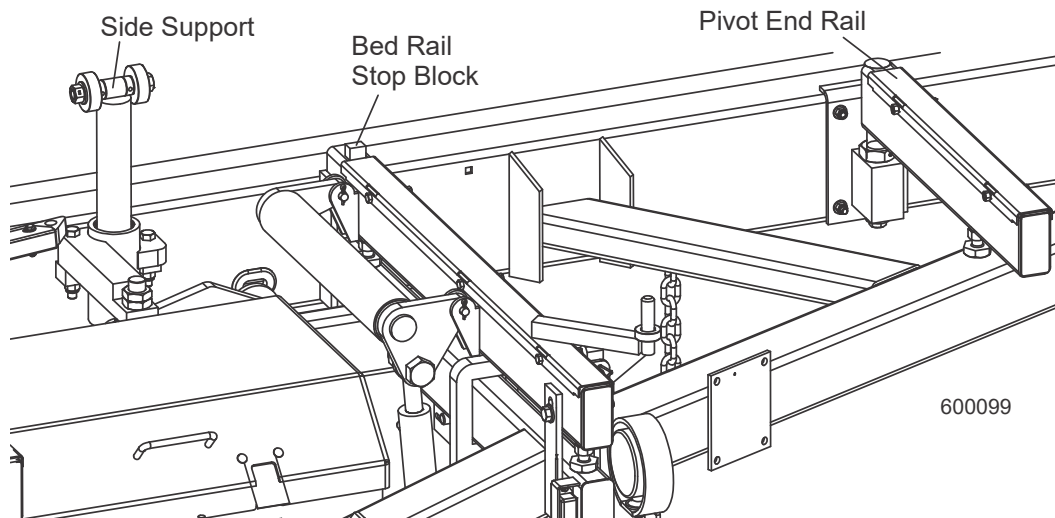

FIG. 3-1

3.2 Portable Sawmill Setup



WARNING! Do not set up the mill on ground with more than a 10 degree incline. If setup on an incline is necessary, put blocks under one side of the mill or dig out areas for outrigger legs to keep mill level. Setting up the mill on an incline could cause it to tip over, resulting in serious personal injury.

WARNING! Chock the trailer wheels to prevent movement before unhitching it from the towing vehicle. Failure to do so may result in serious injury or death.

WARNING! Always make sure the trailer is supporting the sawmill frame when operating a sawmill with adjustable outriggers. Failure to do so may result in serious injury or death. The adjustable outriggers are intended to support the saw frame with assistance from the trailer.

WARNING! The adjustable outriggers supplied with portable sawmills are not intended for setup on concrete or other hard surfaces. Long-term use of the adjustable outriggers on hard surfaces may cause the outriggers to fail, causing the sawmill to drop. This could result in possible serious injury or death.

If setting the sawmill up on concrete or other hard surface, replace the adjustable outrigger legs with stationary legs.

1. Unhitch the mill from the vehicle.
2. Lower and set the front three outriggers. To lower, use the provided jack handle to lift the weight from the locking pin. If necessary, rotate the locking pin counterclockwise so that the inner roll pin is free from the outrigger channel notch, then pull the locking pin out to release the outrigger. Lower the outrigger as necessary. Push the locking pin back in and turn clockwise until the inner roll pin is behind the outrigger channel notch to “lock” the outrigger in place.



WARNING! Put front outrigger down before moving cutting head from the rest position. Failure to do so may result in serious injury.

See Figure 3-2.

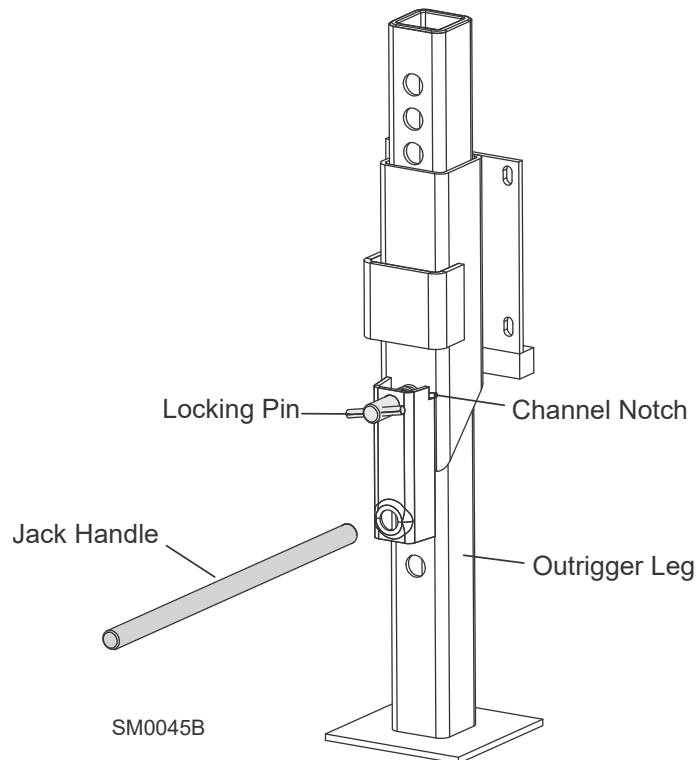

FIG. 3-2. OUTRIGGER ADJUSTMENT.

If sawmill is equipped with optional Fine Adjust Outriggers (FAO), see the option manual for outrigger operation.

1. Unhook the carriage safety chain, located at the bottom of the vertical mast.
2. Start the engine to enable the battery-operated accessories ([See Section 3.6](#)). Use the up/down switch on the control box to raise the cutting head from the carriage rest pin. Remove the locking pin and swing the rest pin down below bed level.



CAUTION! DC Models Only: Always make sure the engine is running before operating the sawmill controls. Operating the controls without the engine running will result in power drainage from the battery.

3. Remove the fenders by lifting them out of the slots.



CAUTION! To prevent fender damage, remove fenders before operating sawmill or loading logs.



4. Use the feed control switch (left side of control box) to move the cutting head toward the front end of the mill.

3

Sawmill Setup

Portable Sawmill Setup

5. Lower and set the remaining rear outriggers. Level the sawmill by adjusting the outriggers to raise or lower each end of the sawmill. Adjust all outriggers evenly to avoid twisting the mill frame by jacking one outrigger higher than the others.

For FAO(s), fine tune the outrigger base height as necessary. Move the cutting head to the opposite end of the mill from the outrigger. Raise the entire outrigger (to remove the sawmill weight from it) and adjust the outrigger base as necessary. Lower the entire outrigger and use the locking pin to secure in position.



CAUTION! Do not adjust the FAO outrigger base height while there is weight on the FAO. Damage to the FAO may result.

6. Raise the two side supports to prevent the log from falling off the side of the mill when loaded.

See Figure 3-3.

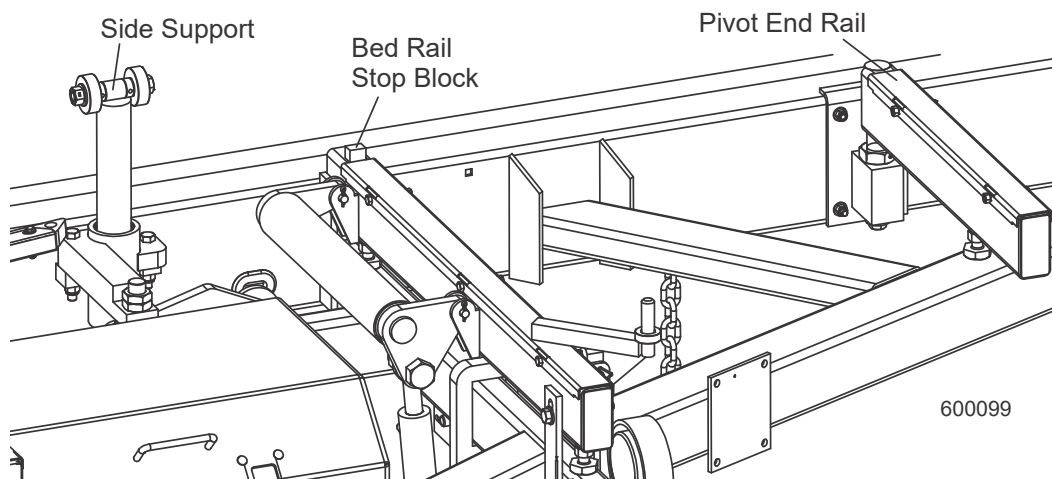

FIG. 3-3

3.3 Replacing The Blade



DANGER! Always disengage the blade and shut off the sawmill engine before changing the blade. Failure to do so will result in serious injury.



WARNING! Always wear gloves and eye protection when handling bandsaw blades. Changing blades is safest when done by one person! Keep all other persons away from area when coiling, carrying or changing a blade. Failure to do so may result in serious injury.

1. Open the two blade housing covers that cover the blade wheels.
2. Turn the blade tension handle to release the blade tension until the wheel is pulled in and the blade is lying loose in the blade housing.
3. Lift the blade out of the blade housing.
4. Make sure the teeth are pointing the correct direction.

See Figure 3-4. The cutting teeth should be pointing toward sawdust chute.

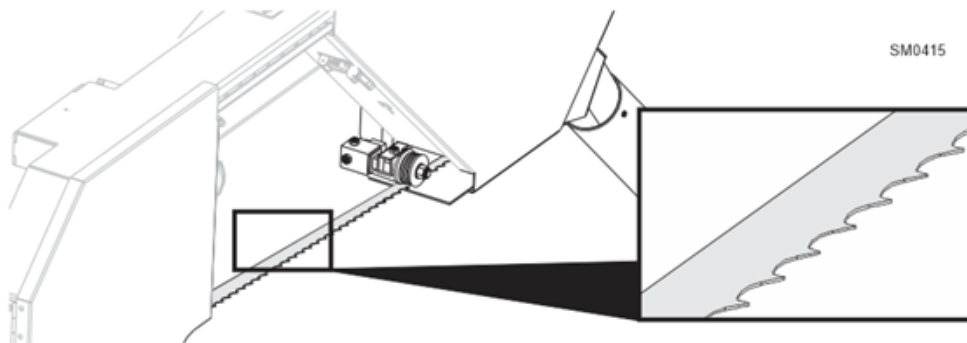

FIG. 3-4

5. Install the blade so it is lying around the wheels.



CAUTION! Be careful when placing the blade between the blade guide inserts. If the blade hits one of the inserts hard enough, it could damage the insert.

6. Position 1 1/4" wide blades on the wheels so the gullet is 1/8" (3.0 mm) out from the edge of the wheel. Position 1 1/2" wide blades on the wheels so the gullet is 3/16" (4.5 mm) out from the edge of the wheel.

3

Sawmill Setup

Replacing The Blade

NOTE: Revs prior to A8.01 only: Use the proper spacer behind the blade guide roller to position it properly to the blade. **Rev. A7.02 - A8.00 or if blade guides retrofitted:** Use 1/8" spacer 052364 for 1 1/2" blades or 1/4" spacer 041626 for 1 1/4" blades. **Revisions prior to Rev. A7.02 with original blade guide design:** Use no spacer for 1 1/2" blades or 1/8" spacer 052364 for 1 1/4" blades.

7. Close the blade housing covers.
8. Use the tension handle to tension the blade correctly.

3.4 Tensioning The Blade

See Figure 3-5. Before tensioning the blade, check the air pressure gauge to see that the air tension system is properly charged. With the blade tension completely released and the air bag plate against the stop bolt, the gauge should read 85 psi for all blade types. To add air pressure, remove the air valve stem cover and attach an air pump to the air valve. Add air until the gauge indicates the proper air pressure. To release air, push in the valve stem. Replace the air valve stem cover when finished adjusting the air pressure.

LT70 Rev. B6.05+/LT70 Super Rev. A4.01+: To tension the blade, turn the release valve clockwise to close. Pump the lever until the air bag plate is approximately 1/8" (3.0mm) from the stop plate.

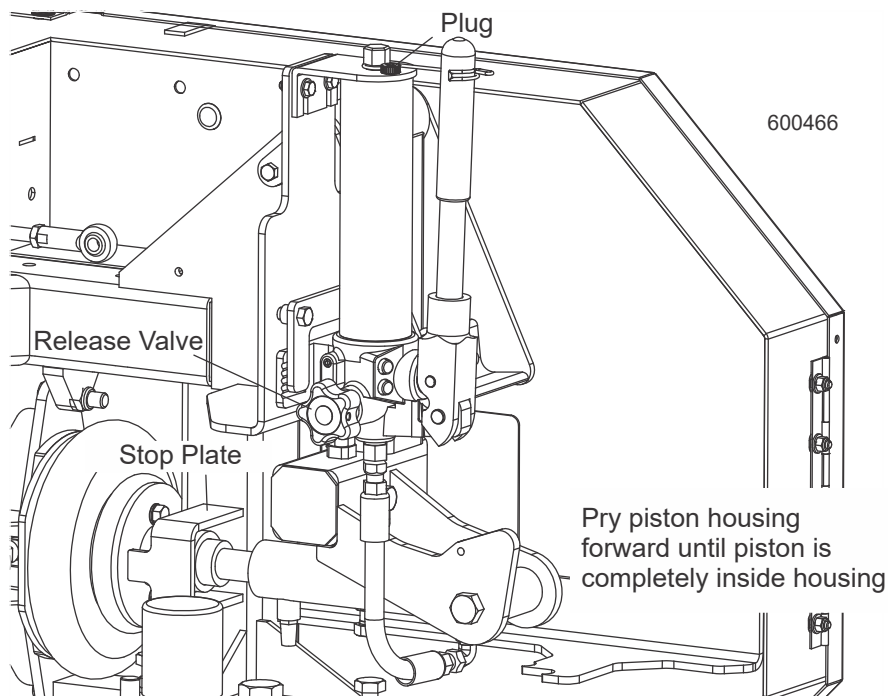

FIG. 3-5 (LT70 REV. B6.05+/LT70 SUPER REV. A4.01+)

To release blade tension, turn the release valve counterclockwise to open. Pry the assembly forward until the blade can be removed.

LT70 Rev. B4.08 - B6.04/LT70 Super Rev. A1.00 - A4.00: Lower the release valve handle (move the handle toward the sawmill operator) and turn the blocking valve counterclockwise to open. Pump the lever until the air bag plate is approximately 1/8" (3.0mm) from the stop plate. Turn the blocking valve clockwise to close. Raise the release valve handle (move the handle away from the sawmill operator) to release pressure from the

3

Sawmill Setup Tensioning The Blade

pump. **IMPORTANT!** Do not exceed the limits as shown below when pumping the lever to avoid destroying the tensioner seal.

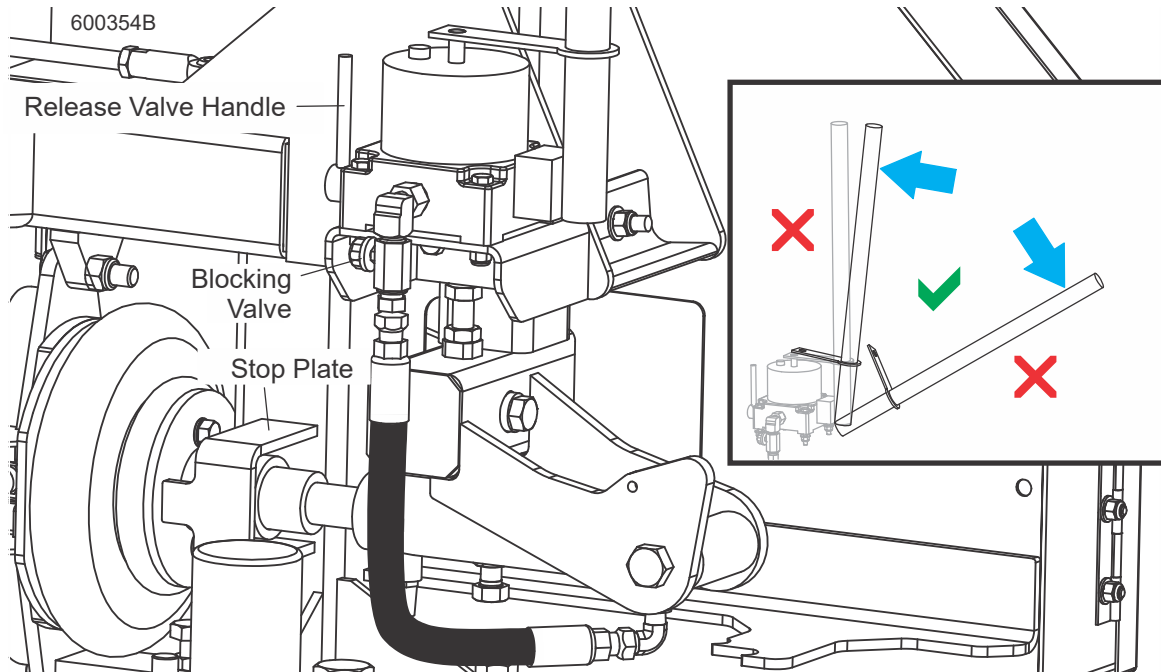

FIG. 3-5

To release blade tension, turn the blocking valve counterclockwise to open and raise the release valve handle. Place the handle between the end of the piston housing and bracket and pry the assembly forward until the blade can be removed.

Rev. A9.00 - B4.07: Adjust the valve handle to the closed (down) position. Install the tensioner handle to the tensioner and pump the lever until the air bag plate is approximately

1/8" (3.0mm) from the stop plate. Remove the tensioner handle and place in the storage position on the tensioner assembly.

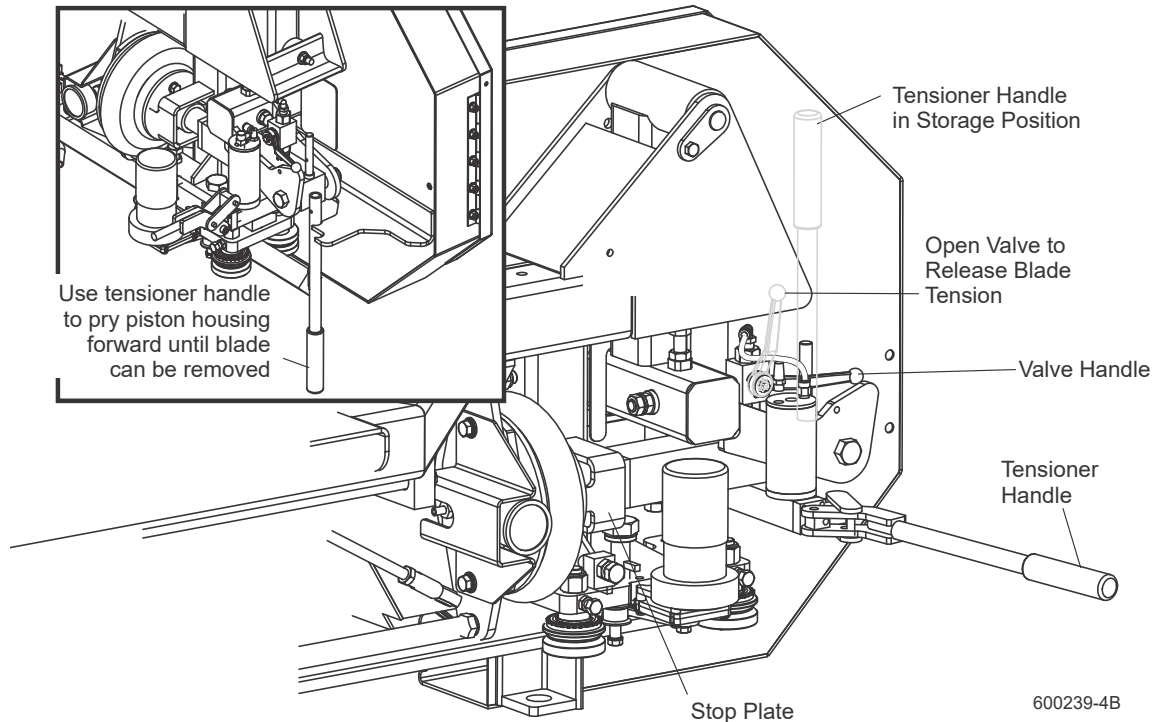

FIG. 3-5 REV. A9.00 - B4.07

To release blade tension, adjust the valve handle to the open (up) position. Place the tensioner handle between the end of the piston housing and bracket and pry the assembly forward until the blade can be removed.

Rev. A5.03 - A8.01: To tension the blade, push the blade tension handle up. Make sure the handle lock flips to the locked (down) position after the blade tension is engaged.



WARNING! Use both hands to operate the blade tensioner handle. Be sure the handle lock engages (flips down) after tensioning the blade. Failure to do so may result in injury.

Check that the air bag plate is approximately 1/8" (3.0mm) from the stop plate (or bolt prior to Rev. A7.03). This should provide approximately 60 psi of blade tension for 1 1/4" blades or 80 psi for 1 1/2" and wider blades. If the gap to the stop plate is not 1/8", release the blade tension by flipping the lock up and pulling the tension handle down. Be sure the handle lock does not flip down when the tension handle is released. Turn the adjustment nut clockwise to increase the stop plate gap, counterclockwise to decrease the gap.

3 Sawmill Setup

Tensioning The Blade

See Figure 3-6.

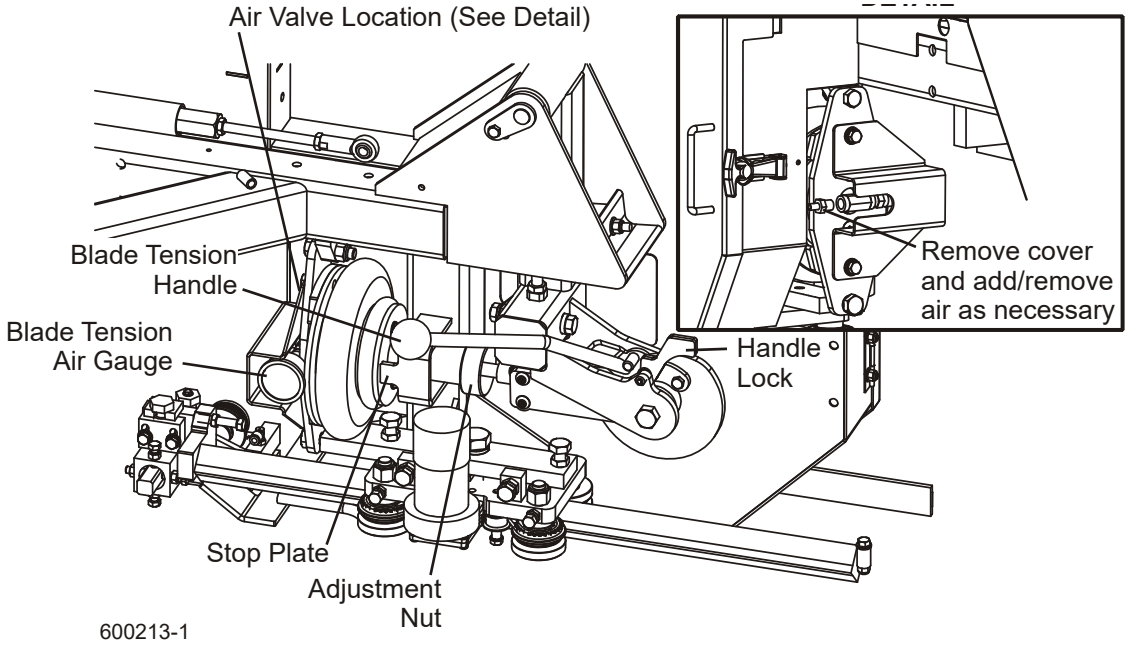

600213-1

FIG. 3-6 (REV. A5.03 - A8.01)

Rev. A3.01 - A5.02: To tension the blade, turn the tension handle clockwise until the air bag plate is approximately 1/8" from the head of the stop bolt. This should provide approximately 60 psi of blade tension for 1 1/4" blades or 80 psi for 1 1/2" and wider blades.

See Figure 3-7.

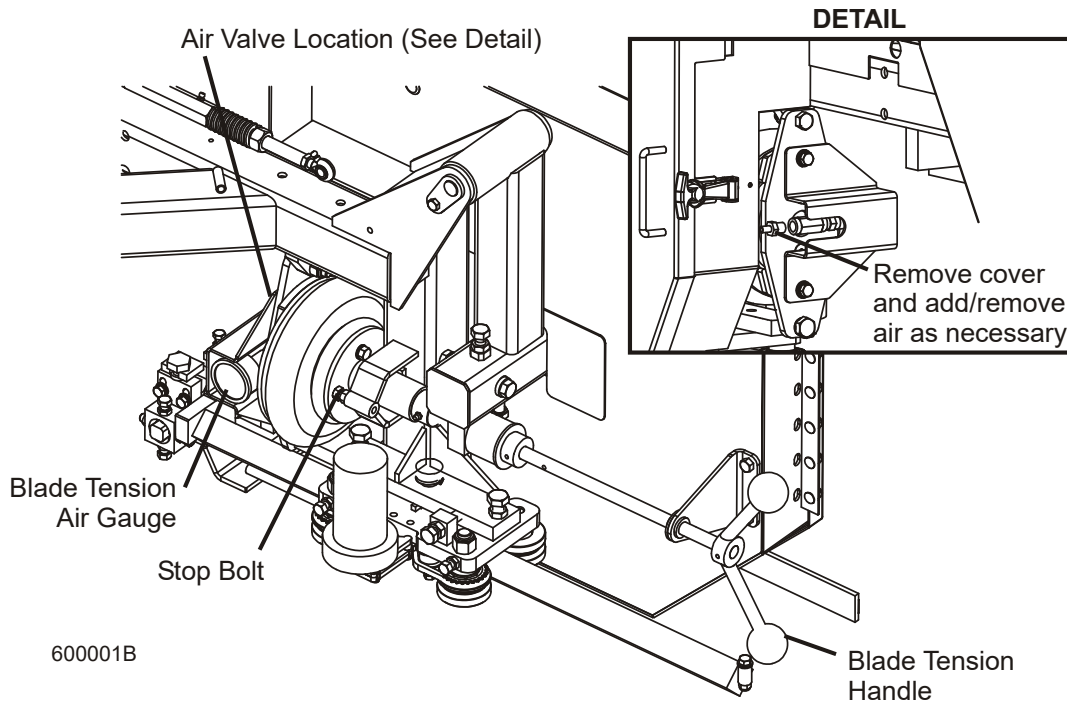

FIG. 3-7 REV. A3.01 - A5.02

The tension gauge should be checked occasionally when adjusting the cant control or while cutting. Ambient temperature changes will cause tension to change. Adjust the tension handle as necessary to maintain the recommended tension level.

3.5 Tracking The Blade

1. Make sure the blade housing covers are closed and all persons are clear of the open side of the saw head.
2. Start the engine (or motor).
3. Engage the blade, rotating the blade until the blade positions itself on the wheels.



WARNING! Do not spin the blade wheels by hand. Spinning the blade wheels by hand may result in serious injury.

4. Disengage the blade. Turn off the engine, remove the key and check the position of the blade on the blade wheels.

See Figure 3-8. Position 1 1/4" wide blades so the gullet is 1/8" (3.0 mm) out from the edge of the blade wheel ($\pm 1/16$ " [1.5 mm]). Position 1 1/2" blades so the gullet is 3/16" (4.5 mm) out from the edge of the blade wheel ($\pm 1/16$ " [1.5 mm]).

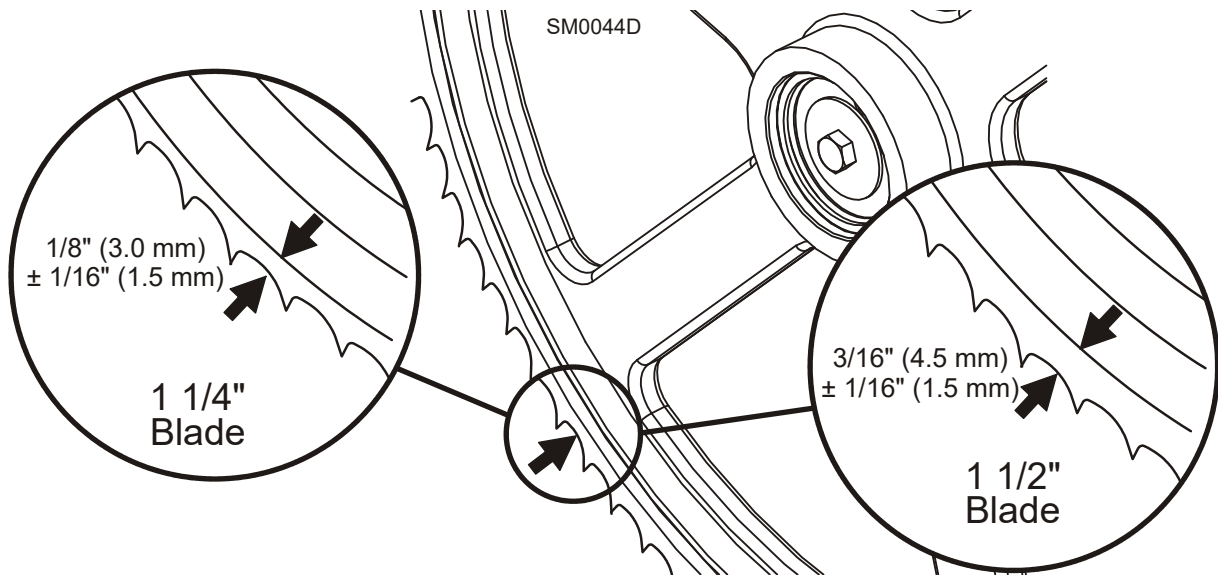

FIG. 3-8

5. Use the cant adjustment bolt to adjust where the blade travels on the blade wheels.

See Figure 3-1.

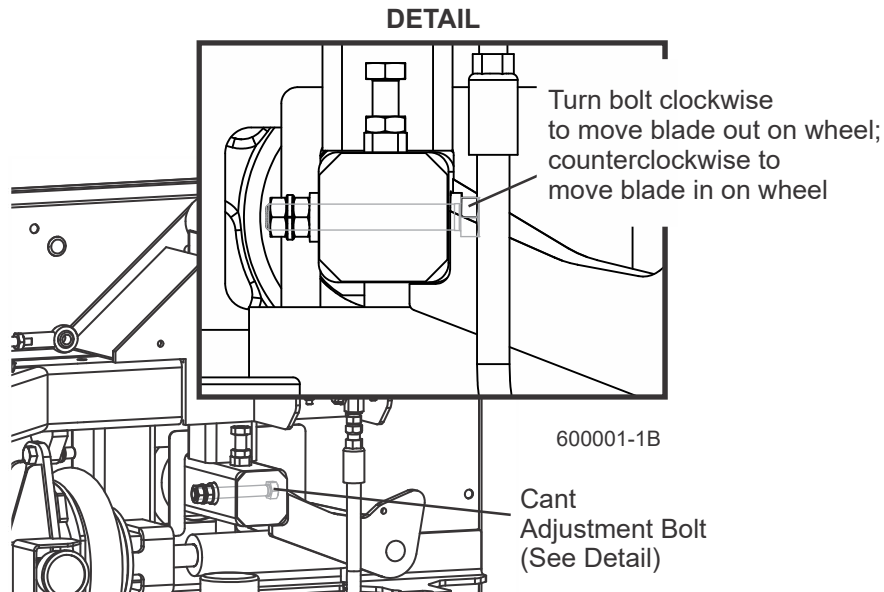

FIG. 3-1

To move the blade out on the blade wheel, turn the cant adjustment bolt clockwise. To move the blade in on the blade wheel, turn the bolt counterclockwise.

NOTE: Slight adjustments of the side bolts on the outer blade wheel are usually all that is necessary to track the blade properly. [See Section 7.2](#) for complete blade wheel alignment instructions.

6. Close the blade housing covers, retension the blade and spin the blade again. Repeat this procedure until the blade tracks on the blade wheels properly.
7. Adjust the blade tension if necessary to compensate for any changes that may have occurred while adjusting the cant control.



DANGER! Make sure all guards and covers are in place and secured before operating or towing the sawmill. Failure to do so may result in serious injury. Be sure the blade housing and pulley covers are in place and secure.



IMPORTANT! After aligning the blade on the wheels, always double-check the blade guide spacing and location. ([See Section SECTION 7](#) for more information.)

3.6 Starting The Engine (or Motor)

See the appropriate manual supplied with your specific engine/motor configuration for starting and operating instructions.



DANGER! Make sure all guards and covers are in place and secured before operating or towing the sawmill. Failure to do so may result in serious injury. Be sure the blade housing and pulley covers are in place and secure.

DANGER! Always be sure the blade is disengaged and all persons are out of the path of the blade before starting the engine or motor. Failure to do so will result in serious injury.



WARNING! Always wear eye, ear, respiration, and foot protection when operating the sawmill. Failure to do so may result in serious injury.

WARNING! Be sure the power feed switch (if equipped) is in the neutral position before turning the key switch to the on (#1) or accessory (#3) position. This prevents accidental carriage movement which may cause serious injury or death.

3.7 Board Return



WARNING! The automatic board return is intended to assist a second operator in removing boards quickly. Do not use the board return when operating the sawmill alone. Serious injury, death or damage to the equipment may result.

WARNING! Never use the board return table as a platform to stand on. This table is designed and intended to assist in the removal of boards only. Standing on the table may result in serious injury.

The sawmill is equipped with a board return system. This system consists of arms on the saw head and a board return table to catch the board as it is removed from the log. Use of the board return not recommended with material shorter than 8 foot.

When the blade reaches the end of the log, the arms will drop down to catch the board and drag it back toward the operator as the saw head is returned.



DANGER! Keep all persons out of the path of returning boards. Failure to do so will result in serious injury.

Boards may not always return in the same path or location. If a board returns in a manner that does not allow the sawyer or off-bearer to maintain control, it may be necessary to stop the reverse motion of the saw head.

When the board return is to be used, a second person is required to remove the board as it is returned. DO NOT attempt to use the board return feature when sawing alone.

3 Sawmill Setup

Board Return

See **Figure 3-9**. To bypass the board return feature, pin the board return arms in the storage position.

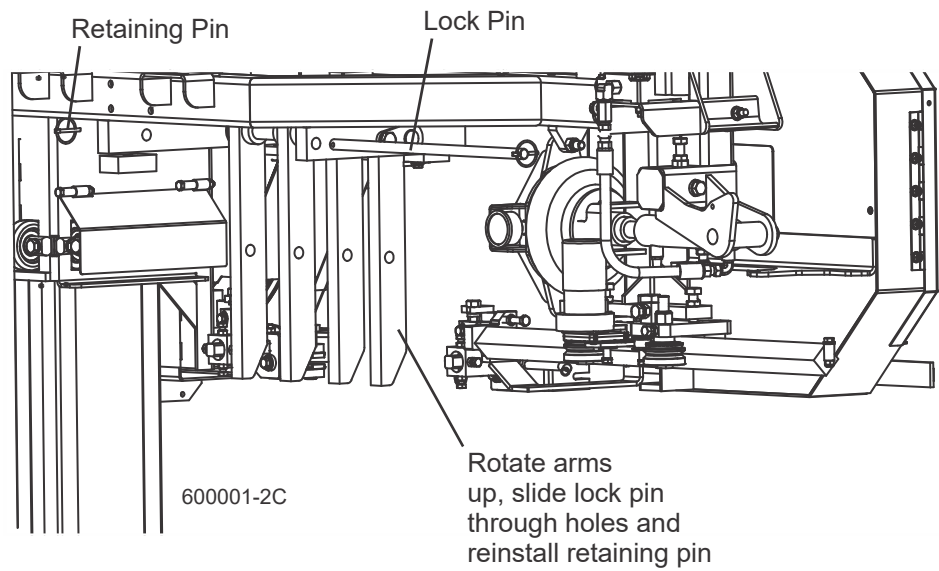

FIG. 3-9

SECTION 4 SAWMILL OPERATION

4.1 Hydraulic Control Operation

208-480V AC sawmill (Rev. A7.00+): The hydraulic controls are operational when the switch on the hydraulic electric control box is pushed in. Push and hold the button in while using hydraulic functions.

DC & 550-600V AC sawmill (All) & 208-480V AC sawmill (Rev. A3.01 - A6.01): The hydraulic control levers become operational when the contacts at the bottom of the carriage touch the power strip on the frame tube. The hydraulic control levers will only work when the cutting head is close enough to the front end of the mill to touch the power strip.

Hydraulic units have seven control levers to load, clamp, turn and level logs.

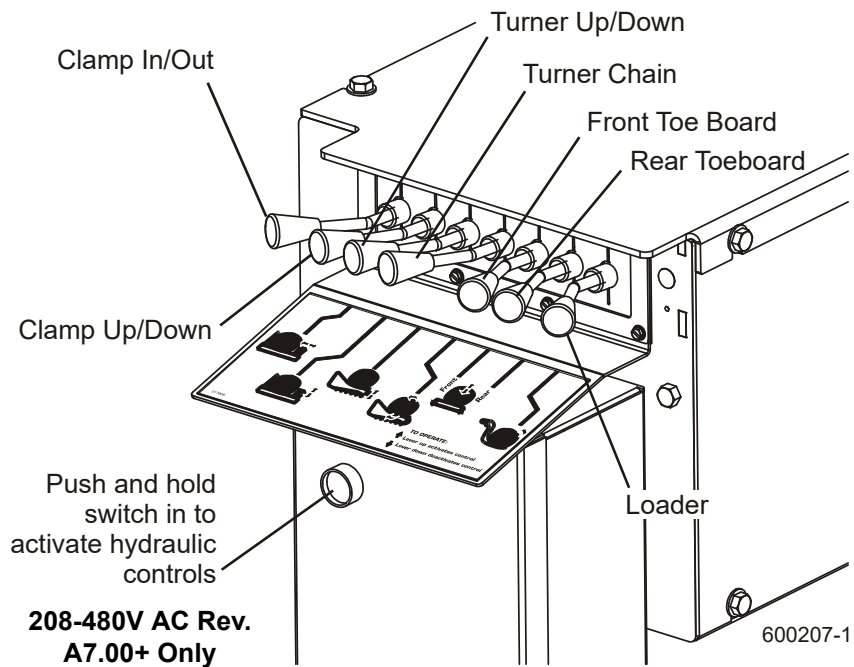



FIG. 4-0

4

Sawmill Operation Hydraulic Control Operation

Use the hydraulic control levers to get the mill ready to load a log.

 **DANGER!** Keep all persons out of the path of moving equipment and logs when operating sawmill or loading and turning logs. Failure to do so will result in serious injury.

 **CAUTION!** Always make sure the engine is running before operating the hydraulic controls. Operating the controls without the engine running will result in power drainage from the battery. Holding the hydraulic switches halfway up or down also will cause excessive drainage from the battery.

1. Move the clamp out and down so it will not get in the way of logs being loaded onto the bed.



Lower the clamp in/out lever to move the clamp out toward the loading side of the sawmill.



Lower the clamp up/down lever to lower the clamp below bed level.

2. Raise the log loader lever to extend the legs of the log loader out as far as they will go.



3. **Wide Head Models Only:** Remove the loading arm lock pin securing the log loading arms in the travel position.

See Figure 4-1.

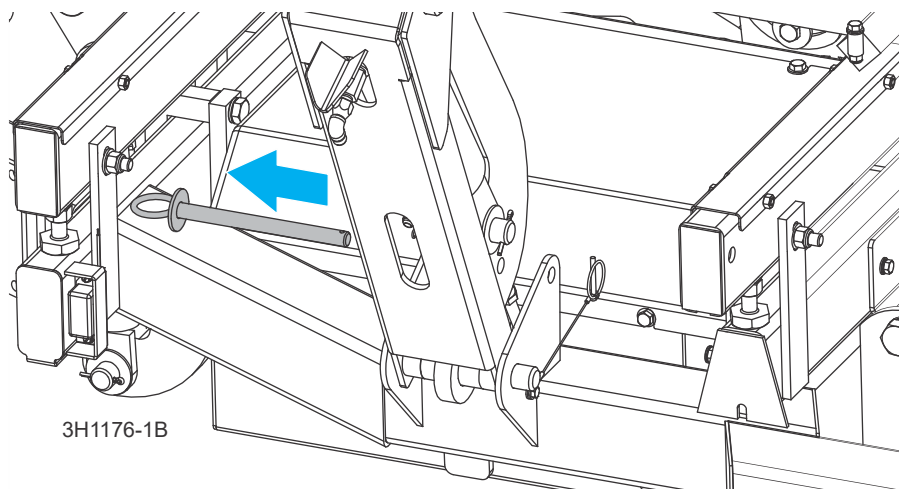

FIG. 4-1



The chain securing the log loading arm to the log turner arm will be tight. Raise the log turner lever to raise the turner arm until there is slack in the chain.

5. Unchain the loading arm from the turner arm.



6. Lower the turner lever to completely lower the turner arm. Notice that after the turner arm is all the way down, the side support braces will begin to lower. Release the turner lever after the turner arm is lowered, but before the side supports begin to lower. This stops the log being loaded from damaging the turner and/or falling off the side of the sawmill.

7. When raising the turner lever, the side supports rise first. After reaching a fully vertical position, the turner arm will engage and start to rise.

8. Manually lower the log loader so it rests on the ground.



CAUTION! Be careful when manually lowering the log loader. Do not drop the loader onto the ground or perform any action which might break the velocity fuse valves on the loader cylinders. These valves control hydraulic flow and are necessary to prevent the loading arm from collapsing during use.



9. Lower the loader lever to lower the loading arm as far as it will go. Logs must be rolled onto the loading arm one at a time for loading onto the bed of the mill.



10. The front and rear toe boards should be below bed level. Once a tapered log has been loaded, the front or rear end of the log may be lifted to parallel the heart of the log to the path of the blade.

The front toe board is raised by lifting the front toe board lever up. The rear toe board is raised by lifting the rear toe board lever up. Once a flat has been made and the log is ready to be turned, push the appropriate toe board lever down to lower either toe board until it falls below the level of the bed.

4.2 Loading, Turning And Clamping Logs

TO LOAD LOGS

1. Start the engine and move the saw carriage to the front end of the frame.



CAUTION! Before loading a log, be sure the cutting head is moved far enough forward so the log does not hit it. Failure to do so may result in machine damage.



CAUTION! Be sure the log clamp, pivot rails, turning arm and toe boards are adjusted out of the path of the log before loading a log onto the bed. Failure to do so may result in machine damage or cause misalignment.

2. Raise the side supports on the sawmill bed to prevent the log from falling off the side of the bed.
3. Use cant hooks or loading equipment to move the log to the foot of the loading arms.
4. Roll the log onto the loader so that it is approximately centered with the sawmill bed. The log turner will operate much easier if the log is centered on the sawmill bed.



DANGER! Keep all persons out of the path of moving equipment and logs when operating sawmill or loading and turning logs. Failure to do so will result in serious injury.

5. Raise the loader to lift the log onto the sawmill bed. Simply let the loader rise until the log rolls onto the mill bed.
6. Raise the clamp up to prevent the log from rolling off the bed.
7. Clamp the log and lower the loading arm. Leave the loading arm about halfway up while squaring the log. This will stop the log from rolling off the side of the mill.



WARNING! Always leave loading arm halfway up while log is on sawmill bed. Failure to do so may result in serious injury or death.

NOTE: Logs also may be loaded onto the mill with a tractor or other equipment specifically designed for that purpose.

TO TURN LOGS

1. Engage the log turner arm. Let the arm rise until it touches the log.
2. Spin the log against the side supports until it is turned the way you want it for the first cut.

TO TURN LOGS (OPTIONAL PROCEDURE)

If you are turning a small cant on a mill with two-plane clamp, you may opt to use the clamp to turn the cant.

1. Lower the clamp below bed level.
2. Move the clamp in, beneath the edge of the cant.
3. Raise the clamp and flip the cant.

TO CLAMP LOGS

1. Clamp the log against the side supports.
2. Lower the turner until the arm falls below the bed.
3. When the turner arm is lowered all the way, the side supports will begin to lower. Back the clamp off slightly, and let the side supports come down until they are positioned below the level of your first few cuts.

TO LEVEL A TAPERED LOG

Raise the front or rear toe board until the heart of the log measures the same distance from the bed rails at each end of the log.

4

Sawmill Operation

Up/Down Operation

4.3 Up/Down Operation

This section describes operation of the up/down system with the standard controls. See the operation section of the Accuset 2 manual for alternate instructions for operating the up/down system.

1. Install a blade, if needed, and check for correct blade tension. ([See Section 3.3](#)).
2. Set the cutting head to the desired height. (The blade height scale shows the height of the blade above the bed rails.)



See Figure 4-2. The up/down switch is located on the right side of the control panel. Use the switch to raise or lower the cutting head. Hold the switch in position until the cutting head reaches the desired height, then release.

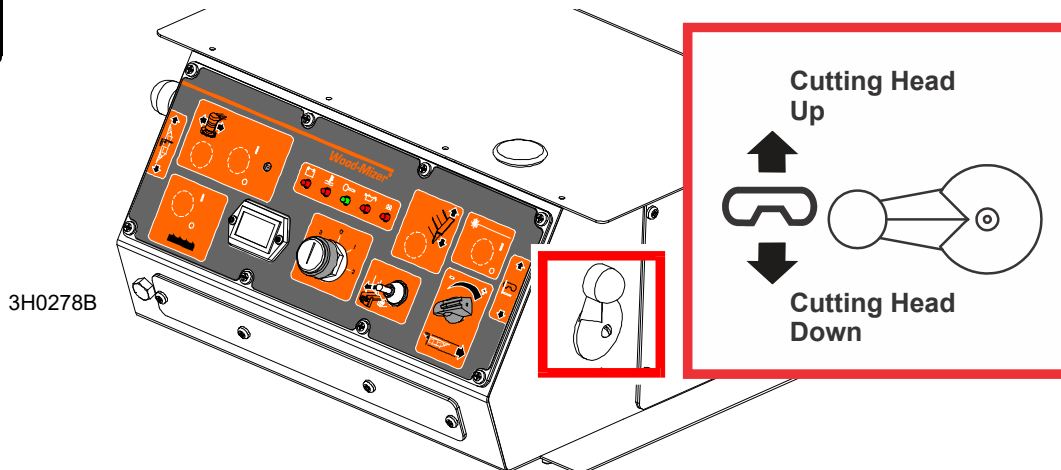

3H0278B

FIG. 4-2

The up/down switch is designed to return to the neutral or "off" position when released. If the switch remains engaged, manually move the switch to the neutral or "off" position. Repair the up/down switch ([See Section 6.2](#)).



CAUTION! Always make sure the up/down switch moves to the neutral or "off" position when released to ensure that the saw head stops moving. Failure to do so may result in machine damage.



CAUTION! DO NOT try to force the carriage above the 35" (88 cm) mark or below the 1" (2.54 cm) mark. Damage to the up/down system may result.

4.4 Blade Guide Arm Operation

1. Look down the length of the log to see its maximum width. The outer blade guide should be adjusted to clear the widest section of the log by less than 1" (25.4 mm).



2. Use the blade guide toggle switch on the control panel to adjust the outer blade guide as necessary. Push the switch to the left to move the arm in. Push the switch to the right to move the arm out.



See Figure 4-3.

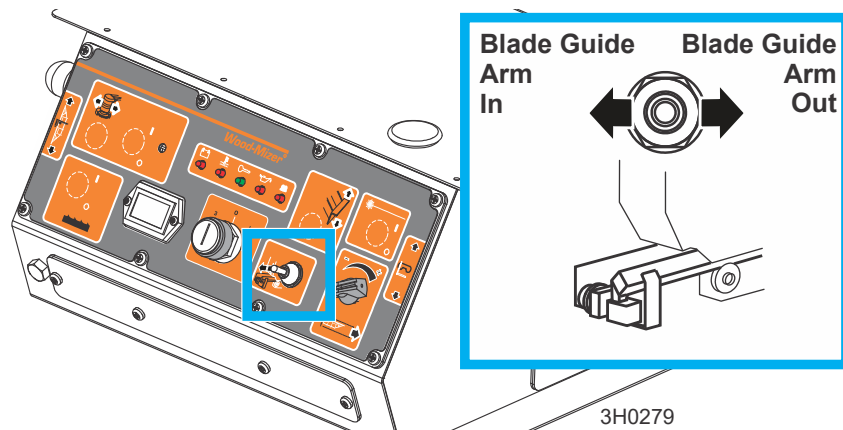

FIG. 4-3

3. Use the blade guide toggle switch to readjust the outer blade guide as you are cutting in order to keep the guide within 1" (2.5 cm) of the log. Be sure to adjust the arm back out before returning the carriage.

4.5 Autoclutch Operation

AC Models: The blade will engage when the key switch is turned to the ON (#1) position.

DC Models: The sawmill is equipped with an automatic clutch mechanism that remotely engages/disengages the blade using a switch on the control box.



See Figure 4-4. To engage the blade, push the toggle switch on the control panel up. Hold the switch up until the clutch motor stops completely. The autoclutch mechanism will disengage the brake, rev the motor to full throttle, and start the blade spinning.



DANGER! Keep all persons out of the path of moving equipment and logs when operating sawmill or loading and turning logs. Failure to do so will result in serious injury.

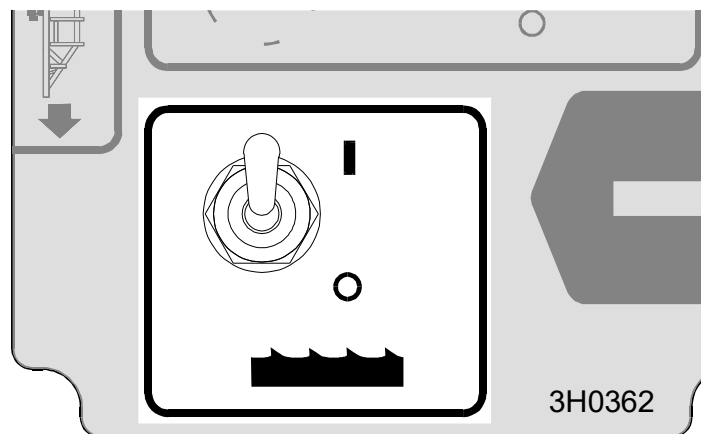

FIG. 4-4

To stop the blade and engage the blade brake, push the toggle switch down. This will also return the engine to idle.

NOTE: Be sure the toggle switch stays in the up or down position. The boot on the switch may spring the switch back to neutral. You may need to hold the switch in position until the remote clutch motor completes its cycle.

4.6 Power Feed Operation

The power feed system moves the carriage forward and backward by using two switches on the control panel.

See Figure 4-5. .

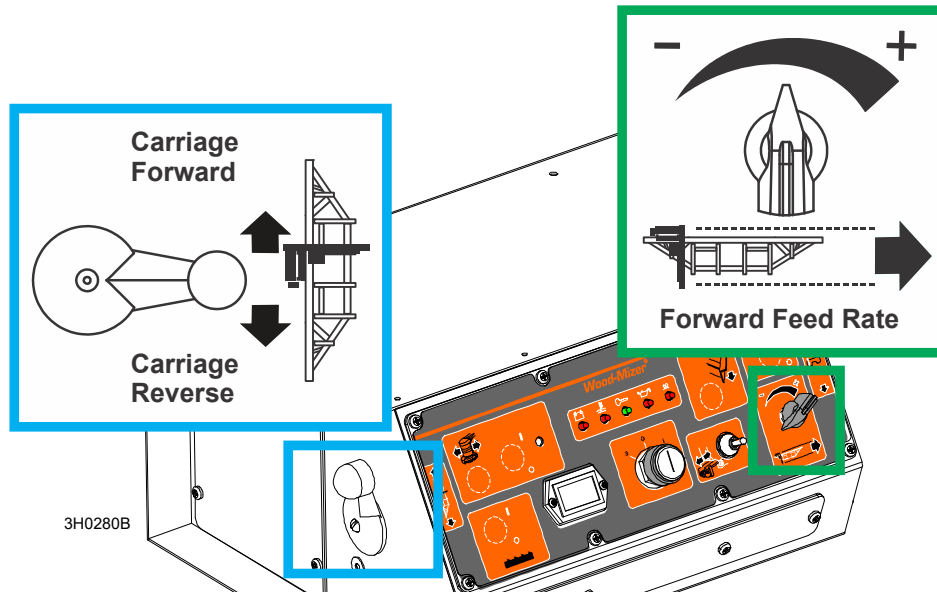

FIG. 4-5

CARRIAGE FEED RATE



The carriage feed rate switch controls the speed at which the carriage travels forward. Turn the switch clockwise to increase speed. Turn it counterclockwise to reduce speed.

CARRIAGE FORWARD AND REVERSE



The carriage forward/reverse switch controls the direction in which the carriage travels. Use the forward/reverse switch to move the carriage forward or backward.



The middle position (as shown) is the neutral position. The power feed switch is designed to return to the neutral or "off" position when released from operating in the reverse position. If the switch remains engaged, manually move the switch to the neutral or "off" position. Repair the switch ([See Section 5.6](#)).



WARNING! Be sure the power feed switch is in the neutral position before turning the key switch to the on (#1) or accessory (#3) position. This prevents accidental carriage movement which may cause serious injury or death.

USING THE POWER FEED

1. To move the carriage forward, push the forward/reverse switch forward and turn the feed rate switch clockwise.



HINT: To get a straight cut in the first part of the board, feed the blade into the log at a slow speed. This stops the blade from flexing and dipping up or down. Turn the carriage feed rate switch to a slow speed until the whole width of the blade has entered the cut.



Then use the carriage feed rate switch to increase the feed rate as desired. Maximum feed rate varies with width and hardness of the wood. Over-feeding results in engine and blade wear, and also produces a wavy cut.

2. Stop the carriage at the end of the cut by turning the carriage feed rate switch counter-clockwise until the carriage stops moving. **DC Models Only:** Throw the autoclutch toggle switch down to stop the blade and drop the engine to idle. Remove the board from the top of the log. **Always disengage the blade before returning the carriage for the next cut.**



CAUTION! DC Models Only: Be sure to stop the blade when returning the carriage. This will not only prevent the blade from being pulled off and ruined by a wood sliver, but also will increase the life of the blade. [See Section 4.9](#) for optional sawing procedure.

AC Models Only: The blade will continue to spin as long as the blade motor is on. Use the optional sawing procedure described in Section 4.9 Optional Cutting Procedure.

3. Make sure that the blade does not catch on the end of the log. Raise the carriage slightly to make sure the blade clears the log when returned.
4. Return the carriage to the front of the mill by pushing the forward/reverse switch down.



The power feed motor will bypass the carriage feed rate switch and the carriage will automatically return at the fastest speed available. [See Section 4.9](#) for optional sawing procedure.

HINT: Try to stop the blade while the heel of the blade is still on the log. Then bring the carriage back without adjusting the blade up. This lets you keep the blade at the current height setting so you can make the next blade height adjustment more quickly.



DANGER! Stay clear of the area between the trailer axle and saw carriage. Failure to do so will result in serious injury.

4.7 Cutting The Log

1. Once the log is placed where you want it and clamped firmly, move the saw head to position the blade close to the end of the log.

2. Use the blade height scale to determine where to make your first cut ([See Section 4.10](#)). The blade height scale will help you to do this. Set the blade to the desired height with the up/down switch. Make sure that the blade will clear all side supports and the clamp.



Adjust the outer blade guide to clear the widest section of the log by moving the blade guide toggle switch.

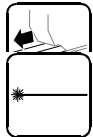

NOTE: An optional laser sight is available to help determine where the blade will travel through the log. See the laser sight manual for detailed operating instructions.

3. **DC Models Only:** Engage the autoclutch blade switch to start the blade spinning.



Start the water lube if necessary to prevent sap buildup on the blade. [See Section 4.11](#).

5. Feed the blade into the log slowly ([See Section 4.6](#)). Once the blade completely enters the log, increase the feed rate as desired. Always try to cut at the fastest speed you can while keeping an accurate cut. Cutting too slowly will waste blade life and lower production!



6. As you get to the end of the log, slow down the feed rate. When the teeth exit the end of the log, stop the carriage. **DC Models Only:** Disengage the autoclutch blade switch. Remove the slab that you have just cut from the log.



7. Use the carriage forward/reverse switch to return the carriage to the front of the mill.



Repeat until the first side of the log is cut as desired. Set aside the usable flitches (boards with bark on one or both sides). You can edge them on the mill later.

9. Lower the toe boards, if they were used. Use the hydraulic levers to release the clamp and engage the log turner. Turn the log 90 or 180 degrees. Make sure the flat on the log is placed flat against side supports if turned 90 degrees. Make sure it is placed on bed rails if turned 180 degrees. If the log was turned 90 degrees and you are using toe boards to compensate for taper in the log, raise the front or rear toe board again on the second side of the log until the heart is parallel with the bed.



10. Repeat the steps used to cut the first side of the log until the log is square. Cut boards from the remaining cant by adjusting the blade height for the thickness of boards that you want.

Example: Remember that the blade cuts a 1/16 - 1/8" (1.6-3.2 mm) wide kerf. If you want 1" (25.4 mm) thick boards, lower the carriage 1 1/16 - 1 1/8" (27-28.6 mm) for each board.

4.8 Edging

1. Raise the side supports to 1/2 the height of the flitches, or the boards that need to be edged.
2. Stack the flitches on edge against the side supports.
3. Clamp the flitches against the side supports halfway up the flitch height. (Wider flitches should be placed to the clamp side. When they are edged, flip them over to edge the second side without disturbing the other flitches or without having to pull them from the middle of the stack).
4. Adjust the blade height to edge a few of the widest boards.
5. Loosen the clamp and turn the edged boards over to edge the other side.
6. Repeat steps 2-4.
7. Loosen the clamp and remove the boards that have good clean edges on both sides. Clamp the remaining flitches and repeat steps 2-5.

4.9 Optional Cutting Procedure

In order to achieve maximum production rates, it may be desirable to leave the blade engaged when returning the carriage. (Normal operation procedures recommend disengaging the blade before returning the carriage for maximum blade life and fuel economy.)



DANGER! If leaving the blade engaged for maximum production rates, make sure the off-bearer stays out of the path of the blade. Failure to do so will result in serious injury or death.



CAUTION! If you choose to leave the blade engaged; raise the blade to clear the log before returning the carriage. Failure to do so may cause damage to the blade and/or sawmill.

4.10 Blade Height Scale

The blade height scale is attached to the carriage head frame. It includes:

- a blade height indicator
- an inch scale
- a quarter scale

See Figure 4-6.

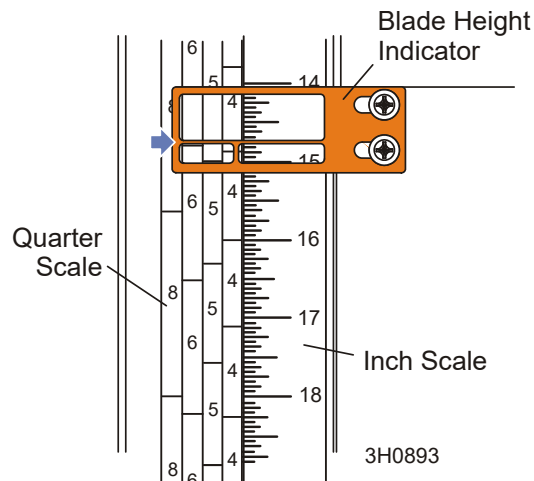

FIG. 4-6

The scales are attached to the frame and move up and down with the saw head. The blade indicator, used to read the inch and quarter scales, remains stationary.

THE INCH SCALE

The horizontal line on the blade height indicator shows how many inches the bottom of the blade is above the bed of the mill. If you know the height of your blade at each cut, you can determine the thickness of lumber you are sawing.

Example: You want to cut 1" (25 mm) random width boards from a log. Position the blade for the first cut. Move the carriage to an even measurement on the inch scale. Make a trim cut. Return the carriage for the second cut and lower it 1 1/8" (29 mm) below the original measurement. (The extra 1/8" (3 mm) allows for saw kerf and shrinkage of the lumber.)

The yellow area on the scale identifies where the blade could encounter a side support or log clamp. Check that these items are below the blade level before sawing.

THE QUARTER SCALE

Two quarter scales are provided with four sets of marks. Each set represents a specific lumber thickness. Saw kerf and shrinkage allowance are included, but actual board thickness will vary slightly depending on blade thickness and tooth set.

To choose which scale to use, determine what finished thickness you want to end up with. The Grade Hardwood Quarter Scale provides thicker finished boards usually required by commercial buyers. The Standard Quarter Scale allows for kerf and shrinkage of finished boards suitable for most custom applications. Always check with your customer before you saw to determine what actual finished thickness is required.

See Table 4-1.

Standard Quarter Scale		Grade Hardwood Quarter Scale	
Scale	Actual Board Thickness	Scale	Actual Board Thickness
4/4	1" (25 mm)	4/4	1 1/8" (29 mm)
5/4	1 1/4" (32 mm)	5/4	1 3/8" (35 mm)
6/4	1 1/2" (38 mm)	6/4	1 5/8" (41 mm)
8/4	2" (51 mm)	8/4	2 1/8" (54 mm)

TABLE 4-1

To use the quarter scale, look at the blade height indicator.

Loosen the wing studs holding the quarter scale to the mast. Align the nearest mark on the scale you want to use with the blade height indicator. Tighten the wing studs.



CAUTION! Be sure to leave the wing studs in the vertical orientation to avoid interference with the blade height indicator. Failure to do so may result in damage to the indicator.

Make a trim cut. When you return the carriage for a second cut, lower the carriage to the next mark on the scale. This mark shows where the blade should be positioned to cut a certain thickness of lumber, without having to measure on the inch scale.

Example: You want to cut 1" (25 mm) (4/4) random width boards from a log. Position the blade for the first cut. Adjust the quarter scale so a 4/4 mark is aligned with the line on the indicator. Make a trim cut. Return the carriage for the second cut. Now, instead of having to measure down 1 1/8" (29 mm) on the inch scale, you can simply lower the blade so the indicator is aligned with the next 4/4 mark on the quarter scale. Turn the log 90 degrees and repeat.

4.11 Water Lube Operation

The Water Lube System keeps the blade clean. Water flows from a 5-gallon (18.9 liter) bottle through a hose to the blade guide where the blade enters the log. A valve in the bottle cap controls the amount of water flow.

See Figure 4-7.

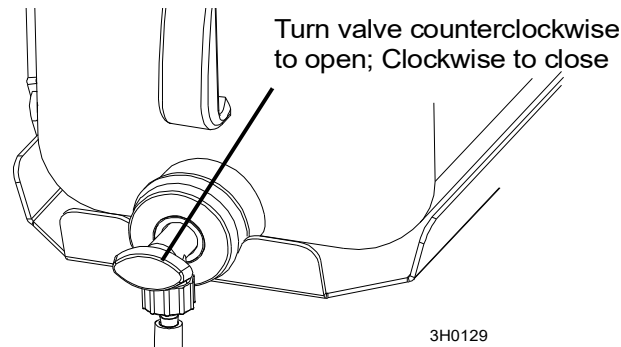

FIG. 4-7

Not all types of wood require the use of the Water Lube System. When it is needed, use just enough water to keep the blade clean. This saves water, and lowers the risk of staining the boards with water. Usual flow will be 1-2 gallons (3.8-7.6 liters) per hour.

Before removing the blade, engage the blade. Let the blade spin with water running on it for about 15 seconds. This will clean the blade of sap buildup. Wipe the blade dry with a rag before storing or sharpening.

For further lubrication benefits, add one 12oz. (0.35L) bottle of Wood-Mizer Lube Additive to 5 gallons (18.9 liters) of water. Wood-Mizer Lube Additive enables some previously impossible timbers to be cut by significantly reducing resin buildup on the blade. It helps to reduce heat buildup, wavy cuts, and blade noise. This biodegradable and environmentally friendly pre-mix includes a water softener additive, so it works with hard water.



WARNING! Use ONLY water and Wood-Mizer Lube Additive with the water lube accessory. Never use flammable fuels or liquids such as diesel fuel. If these types of liquids are necessary to clean the blade, remove it and clean with a rag. Failure to do so can damage the equipment and may result in serious injury or death.



CAUTION! Use windshield washer fluid to the water tank and prime as recommended when sawing or storing the sawmill in below-freezing temperatures. Use windshield washer fluid with a freezing point of at least -20°F (-29°C). Failure to do so may cause damage to the LubeMizer system.

See the separate LubeMizer System manual for operation instructions.

4.12 Preparing The Sawmill For Towing

The Wood-Mizer trailer package makes transporting your sawmill easy and convenient. To get your sawmill ready for towing, follow these instructions.

1. Move the saw carriage to the front end of the sawmill. Raise the rear outriggers.

See Figure 4-8. For Fine Adjust Outriggers (FAOs), make sure the outrigger base is adjusted so that the grease fitting is just below the lowest outrigger hole before securing the FAO in position with the lock pin. This provides maximum ground clearance while preventing the lock pin from hitting the grease fitting.

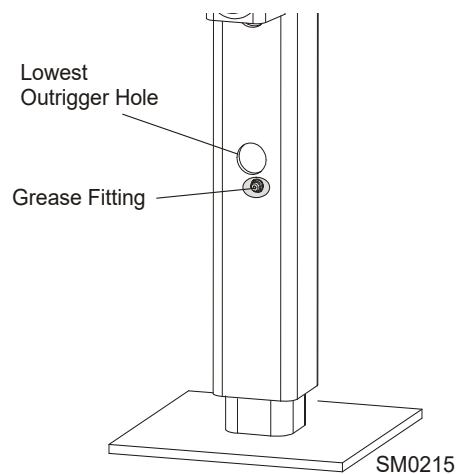

FIG. 4-8. FINE ADJUST OUTRIGGER ONLY.



CAUTION! Be sure the outrigger base is adjusted properly before securing the FAO in position with the lock pin. Failure to do so will cause damage to the outrigger grease fitting.

CAUTION! Do not adjust the FAO outrigger base height while there is weight on the FAO. Damage to the FAO may result.

2. Move the clamp all the way in toward the main bed frame tube.



CAUTION! Move the hydraulic clamp and turner to provide maximum ground clearance before towing. Failure to do so may result in damage to the sawmill.

3. Use the hydraulic controls to raise the log turner and loader as high as they will go. Manually lift the loader and hook the loader chain to the turner. Use the hydraulic turner lever to lower the turner until the chain is tight. Push the loader lever down to bring the loader arm channels up to the loader.
4. Move the carriage forward to the travel position over the rear bed rail.

5. Position the hole in the saw head over the travel rest pin.
6. Lower the saw head until it is seated firmly on the rest pin.
7. Secure the rest pin in the vertical position with the locking pin.

See Figure 4-9.

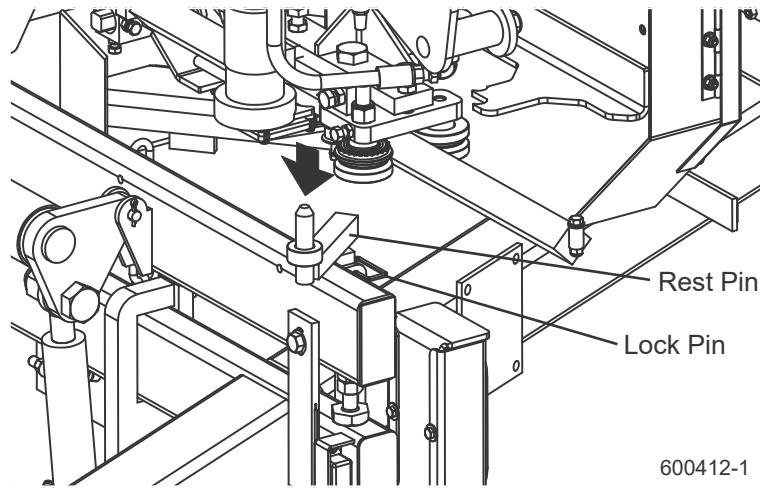

FIG. 4-9

8. Continue lowering the head 3/4" (19mm) until it contacts the stop block at the bottom of the mast.



CAUTION! It is important that the lower stop bolt is properly adjusted to secure the carriage on the track rail. Failure to properly adjust the stop bolt can cause saw head damage, especially during mill transportation.

4

Sawmill Operation

Preparing The Sawmill For Towing

9. If necessary, adjust the stop located at the bottom of the mast so the saw head contacts the stop after it is lowered 3/4" (19mm) past where it contacts the rest pin.

See Figure 4-10.

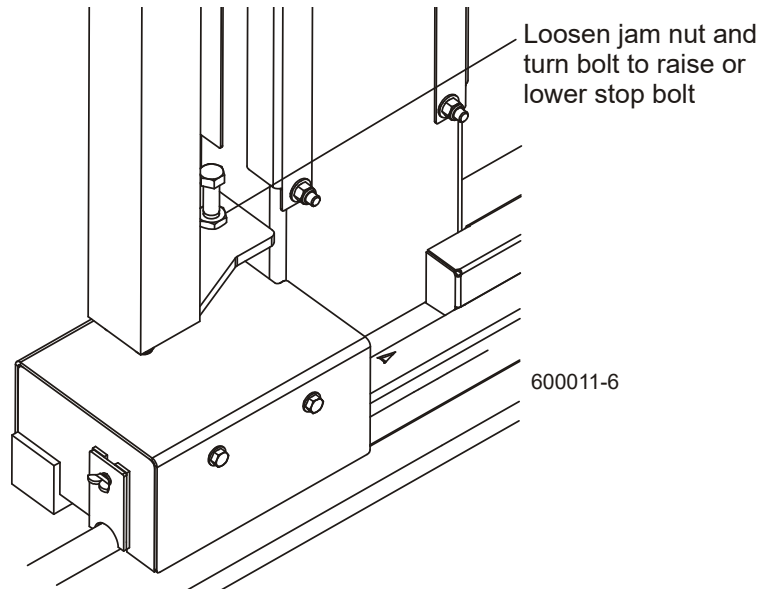

FIG. 4-10

10. Engage the autoclutch blade switch. This keeps the drive belt tight and the motor from bouncing while traveling. Be sure to disengage the autoclutch blade switch after reaching the destination to avoid deformation of the drive belt.
11. Hook the carriage safety chain located at the bottom of the carriage to the bracket at the bottom of the mast.

See Figure 4-11.

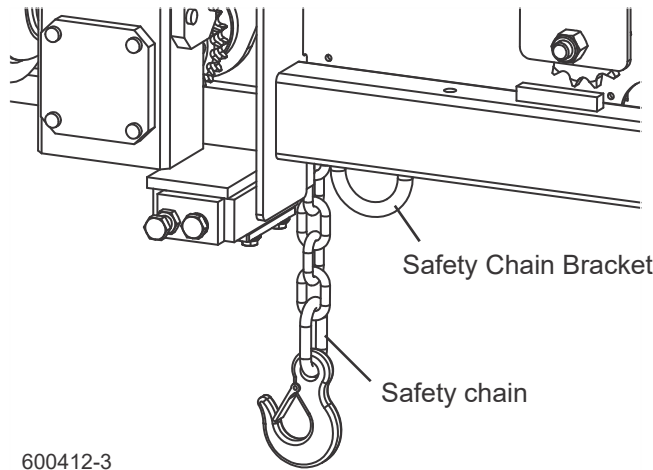

FIG. 4-11



CAUTION! Check to be sure the saw head safety chain is secured before towing the sawmill. Failure to properly secure the saw head can result in severe machine damage. Be sure the blade housing and pulley covers are in place and secure. Use the safety retainer pin and cable to fasten blade housing covers.

12. Remove all loose objects from the bed of the mill. Store the outrigger jack handle in the bracket provided on the rear/loading-side outrigger guide.
13. Place both fenders in the slots located behind the trailer tires and secure with rubber straps. Raise all but the very front outrigger.

For Fine Adjust Outriggers (FAOs), be sure to adjust the outrigger base height so that the grease fitting is just below the lowest outrigger hole before securing the FAO in position with the lock pin.



CAUTION! Be sure the outrigger base is adjusted properly before securing the FAO in position with the lock pin. Failure to do so will cause damage to the outrigger grease fitting.

CAUTION! Do not adjust the FAO outrigger base height while there is weight on the FAO. Damage to the FAO may result.

See the trailer operator's manual for specific information regarding hitch operation and towing the sawmill.

SECTION 5 MAINTENANCE

This section lists the maintenance procedures that need to be performed.

See the [Maintenance chart](#) located after this section for a complete list of maintenance procedures and intervals. Keep a log of machine maintenance by recording in the machine hours and the date you perform each procedure.



This symbol identifies the interval (hours of operation) at which each maintenance procedure should be performed.

Be sure to refer to option and engine manuals for other maintenance procedures.

5.1 Wear Life

See Table 5-1. This chart lists estimated life expectancy of common replacement parts if proper maintenance and operation procedures are followed. Due to the many variables which exist during sawmill operation, actual part life may vary significantly. This information is provided so that you may plan ahead in ordering replacement parts.

Part Description	Estimated Life
Up/Down Motor Brushes (DC Only)	1000 hours
B72.5 Blade Wheel Belts	400 hours
Up/Down Motor	2000 hours
Hydraulic Pump Solenoid	750 hours
Power Feed Motor Brushes (DC Only)	750 hours
Up/Down Drum Switch	1000 hours
Hydraulic Pump Motor Brushes (DC Only)	750 hours
Power Feed Drum Switch	1200 hours
Power Feed Motor	1500 hours
Up/Down Belt	2000 hours
Drive Belt	1250 hours

TABLE 5-1

5.2 Blade Guides



WARNING! Before performing service near moving parts such as blades, pulleys, motors, belts and chains, first turn the key switch to the OFF (#0) position and remove the key. If the key is turned on and moving parts activated, serious injury may result.

1. Check the rollers for performance and wear every blade change. Make sure the rollers are clean and spinning freely. If not, replace them. Replace any rollers which have worn smooth or have become cone shaped.
2. Inspect the blocks at every blade change for damage or wear. If the block housing is bent or damaged, replace the block assembly. Also, replace the block assemblies before the blocks are worn to a point the blade may contact the lower step or housing.
3. Check the guide blocks are properly spaced from the blade every 25 hours of operation. Use the provided shim or a feeler gauge to check the blocks are adjusted .008" - .010" from the blade.
4. As the blocks wear, the front inside corner will wear more than the body of the block. When the corner wears far enough, sawing performance will be affected even if the body of the block is adjusted properly to the blade. At this point, the block should be replaced. If you have access to the appropriate equipment, you can grind or mill the blocks to a new flat surface and reuse them. It is recommended you develop a routine schedule for replacing the blade guide blocks based on your sawing conditions and experience.



To adjust the top block down, loosen the clamp bolt and mounting bolt. Turn the adjustment bolt clockwise. Retighten the mounting bolt and clamp bolt.

To adjust the bottom block up, loosen the clamp bolt and mounting bolt. Use the provided adjustment tool to turn the adjustment screw clockwise. Retighten the mounting bolt and clamp bolt.



IMPORTANT! The blocks should be parallel to the blade. [See Section 7.2](#) for instructions about checking and adjusting the assembly level with the blade.

See Figure 5-1.

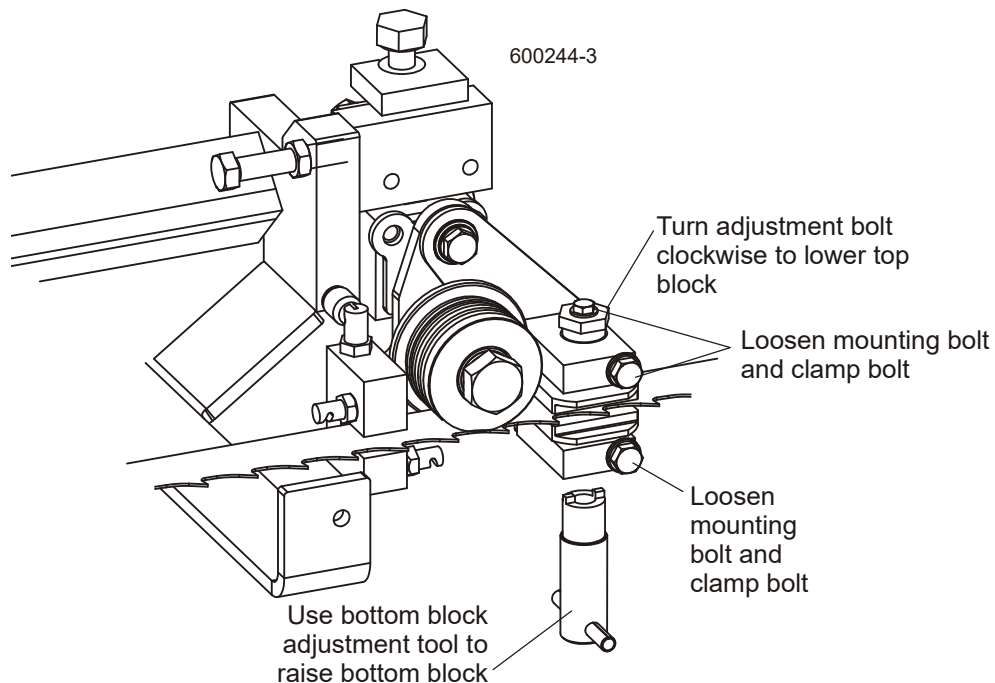

FIG. 5-1

Preventing sap buildup on the blade is critical when using the high-performance blade guide system. If the wood you are sawing leaves sap buildup using plain water in the blade lube system, use Wood-Mizer lube additive (4-Pak 60 oz. bottles part no. ADD-1).

5. Make sure the blade screw in the top center of the C-frame is 1/16" (1.5 mm) away from the blade. If not, loosen the nut and adjust the screw as necessary. Check the screw every 500 hours of operation. Failing to maintain this adjustment will lead to early blade breakage.

See Figure 5-2.

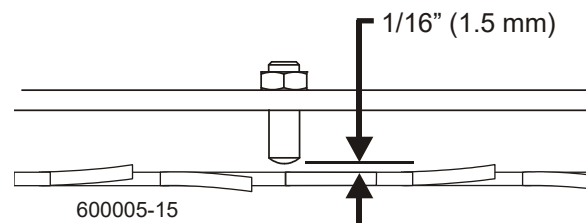

FIG. 5-2

5.3 Sawdust Removal



WARNING! Before performing service near moving parts such as blades, pulleys, motors, belts and chains, first turn the key switch to the OFF (#0) position and remove the key. If the key is turned on and moving parts activated, serious injury may result.



Remove the excess sawdust from the blade wheel housings and sawdust chute every blade change.



WARNING! Always keep clear of exiting sawdust. Keep hands, feet and any other objects away from the sawdust chute when operating sawmill. Failure to do so may result in serious injury.

WARNING! Always check to ensure the steel fingers inside the sawdust chute are in place before operating the sawmill. The steel fingers have been designed to help prevent a broken blade or some other object from becoming a projectile and exiting the sawdust chute. Failure to have these fingers in place may result in serious injury.



Remove all sawdust and debris from around the velocity fuse valves every 8 hours of operation. The valves are located at the bottom of the log loader cylinders.

Remove sawdust buildup as necessary from the battery box lid and top rail cover.



CAUTION! Failure to remove sawdust buildup from the battery box lid and/or track rail cover could result in damage to these parts when the saw head is lowered to its lowest position.



Remove sawdust and debris from grounding block along the bed rail and mast.

5.4 Carriage Track, Wiper & Scraper



WARNING! Before performing service near moving parts such as blades, pulleys, motors, belts and chains, first turn the key switch to the OFF (#0) position and remove the key. If the key is turned on and moving parts activated, serious injury may result.

Properly maintaining the sawmill carriage track is critical in preventing corrosion that can cause pitting and scaling on the rail surfaces. Pitted and scaled surfaces can, in turn, cause rough cuts or jerky power feed movement.

1. Clean track rails to remove any sawdust and sap buildup every eight hours of operation.



Use a light-grade sandpaper or emery cloth to sand off any rust or other adhering particles from the rails.



CAUTION! Keep track rails free of rust. Formation of rust on the track rail in the areas where the cam bearings roll can cause rapid deterioration of the track rail's surface.

Lubricate the rails by wiping them with Dexron III ATF transmission fluid. Lubrication will help protect the rails from corrosive elements such as acid rain and/or moisture from nearby bodies of saltwater (if applicable). This lubrication is essential to maintain the integrity of the track rails and track rollers and to achieve long service life.

2. Remove sawdust from the track roller housings and lubricate the felt track wiper every twenty-five hours of operation.



Remove the track roller housing covers and brush any sawdust buildup from the housings.

Clean and lubricate the felt track wipers. Unbolt the middle track cover, remove from the sawmill and remove any sawdust buildup. Soak the felt wiper with Dexron III transmission fluid.



CAUTION! Reinstall the track wiper so that it lightly touches the track rail. If the wiper presses too firmly against the rail, it can cause the power feed to bind.

- 3.** Check the track scrapers as needed. Make sure the scrapers fit firmly against the rail. If a track scraper needs to be adjusted, loosen the screw, push the scraper downward until it fits firmly against the rail, and retighten the screw.



See Figure 5-3.

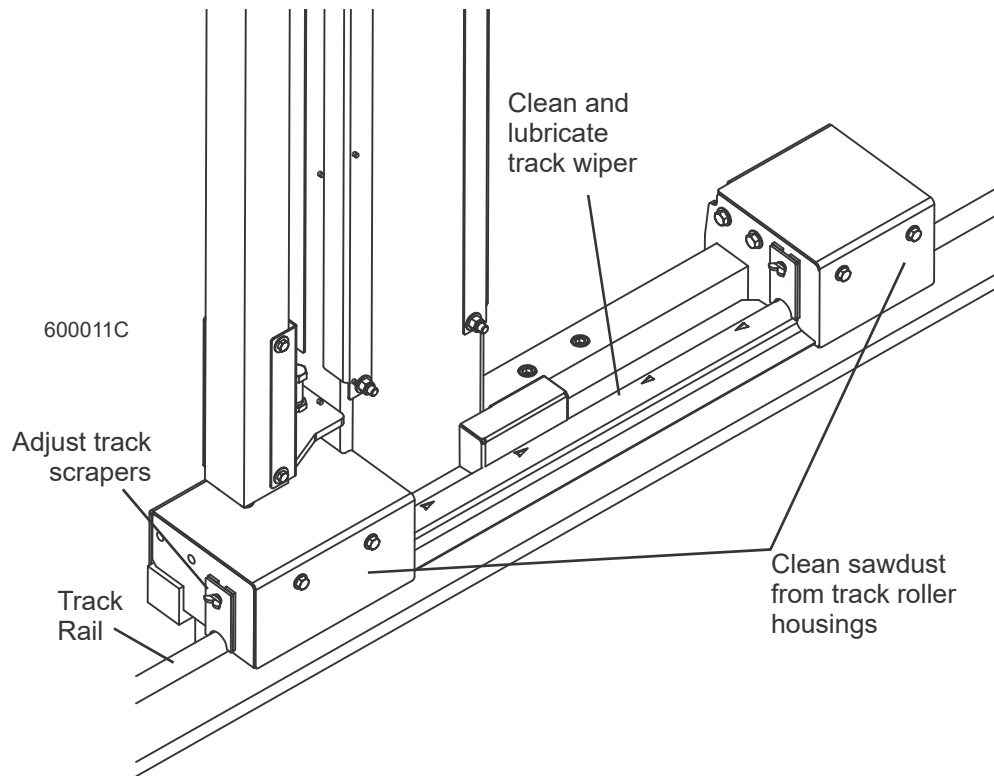

FIG. 5-3

5.5 Vertical Mast Rails



WARNING! Before performing service near moving parts such as blades, pulleys, motors, belts and chains, first turn the key switch to the OFF (#0) position and remove the key. If the key is turned on and moving parts activated, serious injury may result.



Clean the vertical mast rails every 50 hours of operation. Clean with solvent and remove any rust with a light-grade sand paper or emery cloth.



CAUTION! Never use grease on the mast rails as it will collect saw-dust.

5.6 Drum Switches



WARNING! Disconnect and lockout power before performing any service to the electrical system. For battery-powered equipment, disconnect the negative battery terminal cable. For AC-powered equipment, follow the lockout procedure provided in the safety section ([See Section 2.2](#)). Failure to do so may result in injury and/or electrical system damage.



Lubricate the up/down and power feed drum switch contacts inside the control panel every fifty hours of operation. Use only contact grease supplied by Wood-Mizer. Remove the control panel cover. Use a cotton swab to apply grease to the switch contact ends.



WARNING! Drum switch grease contains Petroleum Hydrocarbon Lubricant. Eye and skin irritant. If introduced into eyes, flush with water for at least 15 minutes. If film or irritation persists, seek medical attention. Wash skin with soap and water. If ingested, do not induce vomiting - contact a physician. KEEP OUT OF THE REACH OF CHILDREN.

5.7 Miscellaneous



WARNING! Before performing service near moving parts such as blades, pulleys, motors, belts and chains, first turn the key switch to the OFF (#0) position and remove the key. If the key is turned on and moving parts activated, serious injury may result.

1. Oil all chains with Dexron III ATF every fifty hours of operation.



CAUTION! Do not use chain lube. It causes sawdust buildup in chain links.

2. Apply a thin film of a NLGI No. 2 grade lithium grease to the blade guide arm every fifty hours of operation to help prevent it from rusting.

3. Adjust the blade guide arm drive chain as necessary to prevent the arm from slipping. To adjust the chain, loosen the blade guide arm motor mounting plate bolts and slide the motor to take slack out of the chain.

4. Apply NLGI No. 2 grade lithium grease to the drive belt tensioner pivot every fifty hours of operation.

See Figure 5-4.

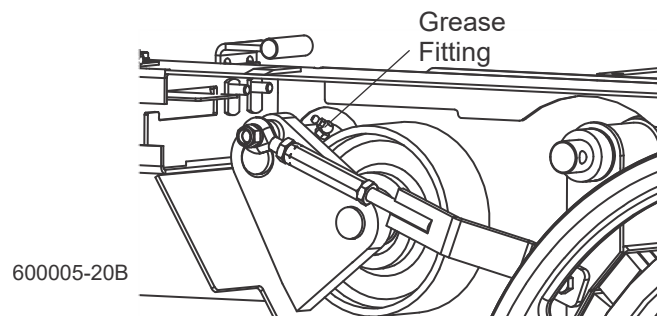

FIG. 5-4

5. Grease the clamp mechanism, loading arm and side support pivots with a NLGI No. 2 grade lithium grease every fifty hours of operation.

6. Check the mill alignment every setup ([See Section SECTION 7](#)).

7. Make sure all safety warning decals are readable. Remove sawdust and dirt. Replace any damaged or unreadable decals immediately. Order decals from your Customer Service Representative.

5.8 Blade Tensioner



WARNING! Before performing service near moving parts such as blades, pulleys, motors, belts and chains, first turn the key switch to the OFF (#0) position and remove the key. If the key is turned on and moving parts activated, serious injury may result.

See **Figure 5-5. LT70 Rev. B6.05+/LT70 Super Rev. A4.01+:** Add fluid such as Dexron III or Conoco MV32 to the tensioner assembly as needed. To add fluid, remove the plug from the pump reservoir and turn the release valve counterclockwise to open. Pry the assembly forward until the tensioner piston is completely collapsed inside the housing. Fill the reservoir to 1/2" (12mm) from the top. Replace the plug to the pump reservoir.

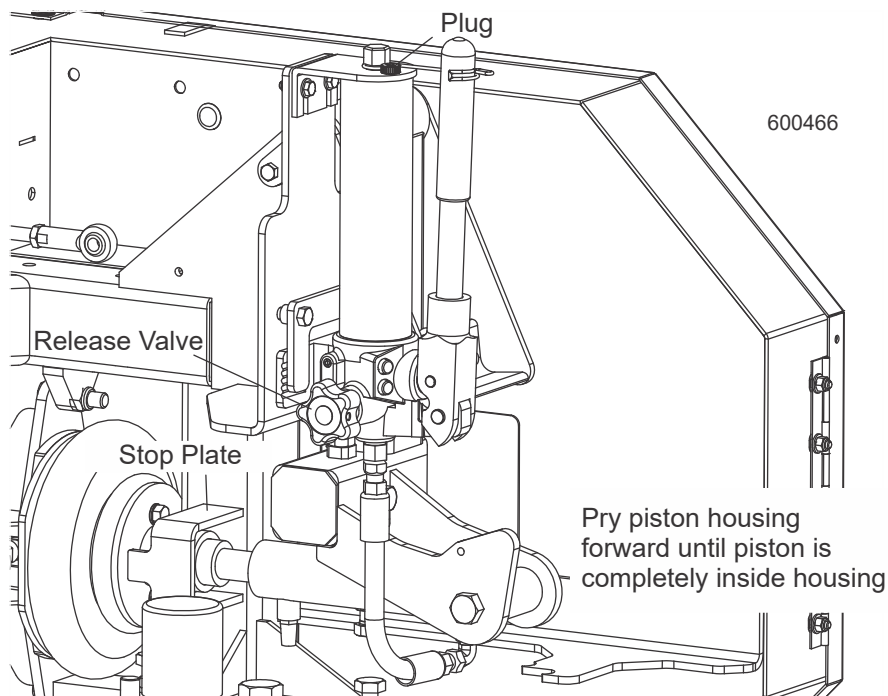

FIG. 5-5 (LT70 REV. B6.05+/LT70 SUPER REV. A4.01+)

See **Figure 5-6. LT70 Rev. B4.08 - B6.04/LT70 Super Rev. A1.00 - A4.00:** Add fluid such as Dexron III or Conoco MV32 to the tensioner assembly as needed. To add fluid, lower the release valve handle and turn the check valve clockwise to open. Remove the plug from the pump reservoir. Place the tensioner handle between the end of the piston housing and bracket and pry the assembly forward until the tensioner piston is completely

collapsed inside the housing. Fill the reservoir to 1/2" (12mm) from the top. Replace the plug to the pump reservoir. Replace the tensioner handle to the hand pump.

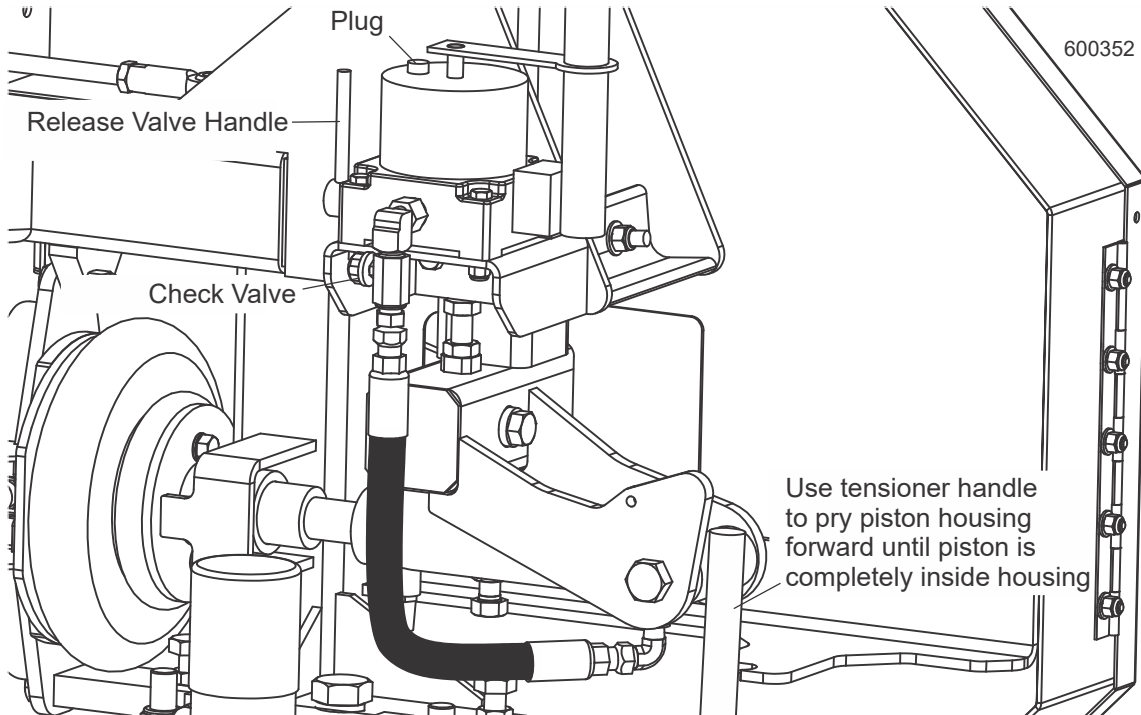

FIG. 5-6

See Figure 5-7. Rev. A9.00 - B4.07: Add fluid such as Dexron III or Conoco MV32 to the tensioner assembly as needed. To add fluid, raise the valve handle and remove the vent fitting from the reservoir cap. Place the tensioner handle between the end of the piston housing and bracket and pry the assembly forward until the tensioner piston is completely

collapsed inside the housing. Fill the reservoir to 1/4" (12mm) from the top. Replace the vent fitting.

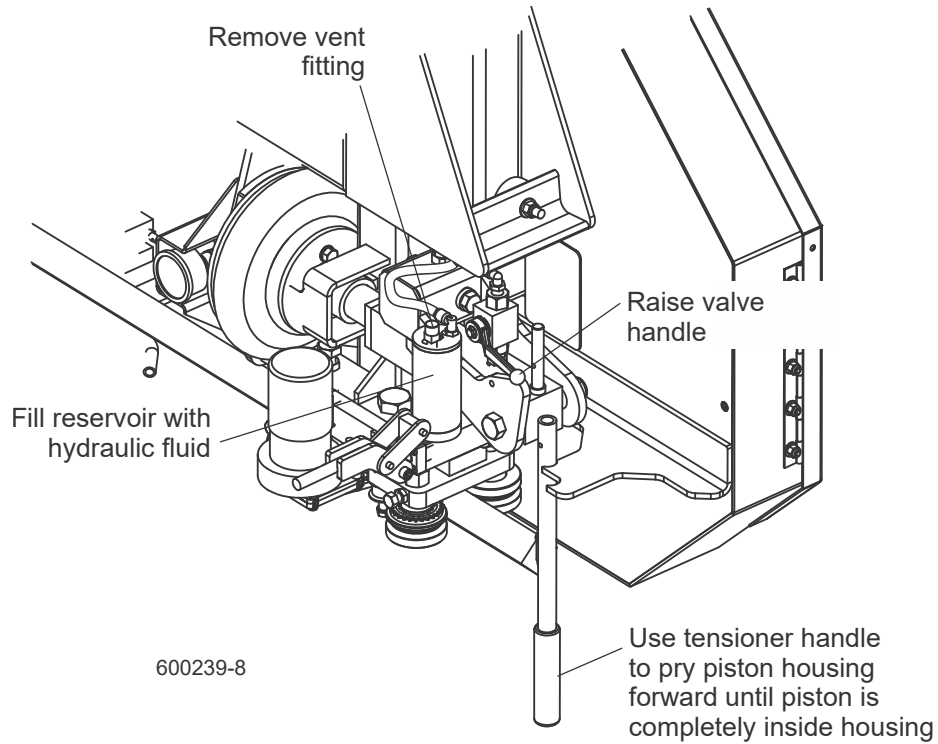

FIG. 5-7 REV. A9.00 - B4.07

8. Lubricate the tensioner screw handle with a NLGI No. 2 grade lithium grease as needed.
- 9.

5.9 Blade Wheel Belts



WARNING! Before performing service near moving parts such as blades, pulleys, motors, belts and chains, first turn the key switch to the OFF (#0) position and remove the key. If the key is turned on and moving parts activated, serious injury may result.



Rotate the blade wheel belts and check them for wear. Rotating the belts every 50 hours will provide longer belt life. Replace belts as necessary. Use only B72.5 belts supplied by Wood-Mizer.

5.10 Drive Belt Adjustment



WARNING! Disconnect and lockout power before performing any service to the electrical system. For battery-powered equipment, disconnect the negative battery terminal cable. For AC-powered equipment, follow the lockout procedure provided in the safety section ([See Section 2.3](#)). Failure to do so may result in injury and/or electrical system damage.



WARNING! Before performing service near moving parts such as blades, pulleys, motors, belts and chains, first turn the key switch to the OFF (#0) position and remove the key. If the key is turned on and moving parts activated, serious injury may result.



WARNING! Do not adjust the engine drive belts or belt support bracket with the engine running. Doing so may result in serious injury.



CAUTION! Do not over-tighten the drive belt. Damage to the engine may result

50

See Table 5-2. See the table below for drive belt tension specifications for your model sawmill. Measure the belt tension with a gauge. **NOTE:** Wood-Mizer offers a belt tension gauge (Part No. 016309) that will let you accurately measure the belt tension.

Engine /Motor	New Belt Installation/New Sawmill Operation				Subsequent Adjustment		
	Deflection Inches (mm)	Installation Force lbs. (kg)	Check After First	Acceptable Force lbs. (kg)	Then Check Every	Deflection Inches (mm)	Force lbs. (kg)
ALL	3/8" (9.5mm)	14 lbs. (6.35kg)	20 hrs	14 lbs. (6.35kg)	50 hrs	3/8" (9.5mm)	14 lbs. (6.35kg)

TABLE 5-2

See Figure 5-8.

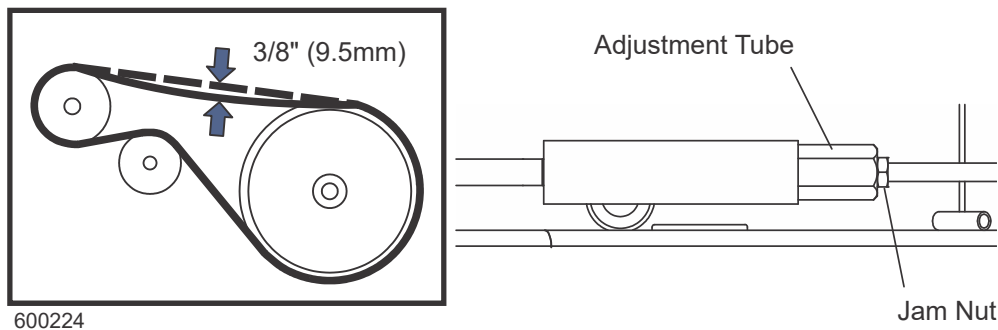

FIG. 5-8

Adjust belt tension

1. Turn the key switch to the accessory (#3) position. Engage the drive belt with the blade switch on the control panel.
2. Turn the key switch to the off (#0) position and remove the key. Check the belt tension as described above.
3. Loosen the jam nut and turn the adjustment tube until the belt is properly tensioned.
4. Tighten the jam nut.
5. **D55 Only:** Adjust the enhancement rods approx. 1/4" away from the belt.

See Figure 5-9.

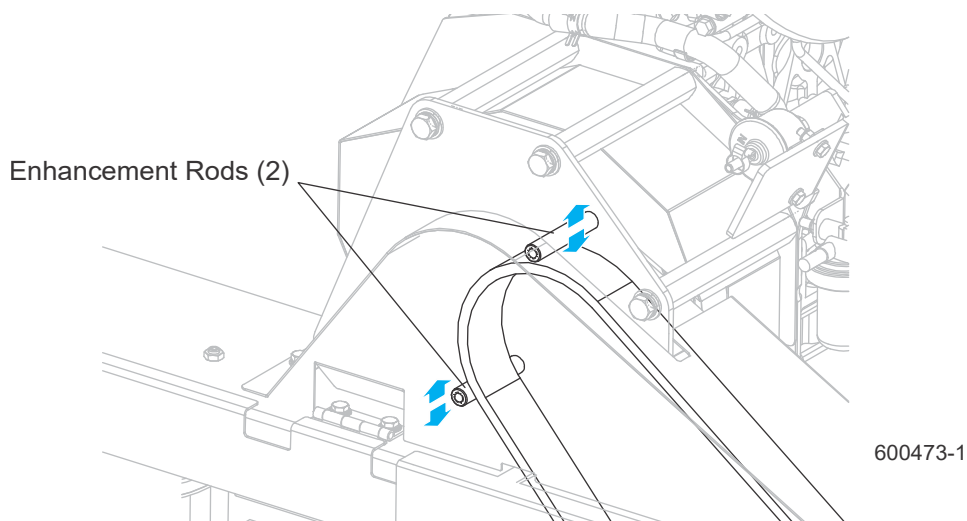

FIG. 5-9 D55 ONLY

6. Replace the key and turn the key switch to the accessory (#3) position. Turn the blade switch off and back on and recheck the belt tension.
7. Repeat adjustments as necessary until proper belt tension is achieved when the belt is engaged.
8. **DC models only:** After making adjustments to the drive belt, always check the brake adjustment ([See Section 5.11](#)).
9. **Prior to LT70 Rev. B6.04 and LT70 Super Rev. A3.01 Only: DC models only:** With the drive belt still tensioned, adjust the belt support bracket to within 1/16" (1.6mm) of the belt.

See Figure 5-10.

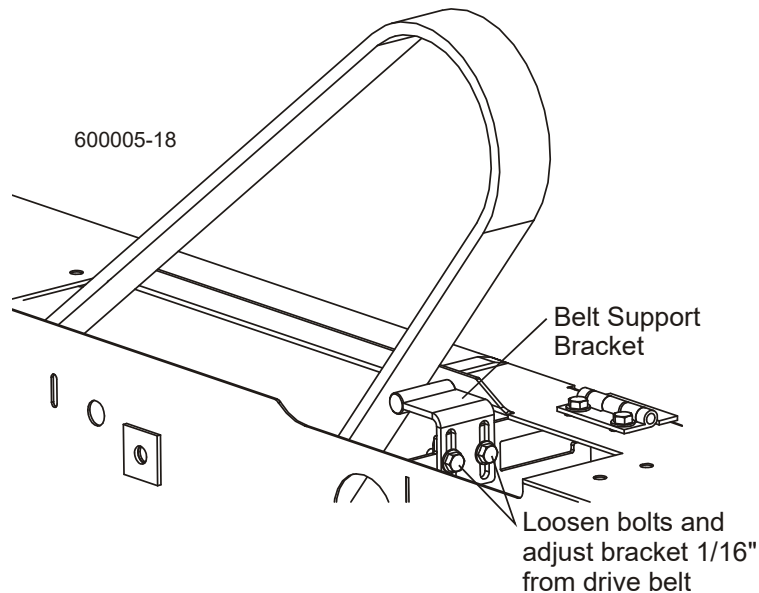

FIG. 5-10 PRIOR TO LT70 REV. B6.04 AND LT70 SUPER REV. A3.01 ONLY

AR Periodically check the drive belt for wear. Replace any damaged or worn belts as needed.

Adjust the drive belt support (Excludes E25, E30, D55)

The drive belt support is designed to extend belt life. The bracket should be adjusted to NOT touch the drive belt when the clutch handle is engaged (down position), AND to hold the drive belt away from the engine pulley when the clutch handle is disengaged (up position).

AR Adjust the drive belt support as needed. Depending on your engine model, the drive belt support may be located near the drive wheel or drive pulley.

1. Ensure the power is off.
2. Loosen the adjustment bolts.
3. Position the bracket so that the rod is close to, but does not touch, the drive belt with the clutch handle engaged. This is approximately 1/8-1/16" (3-1.5mm).
4. Retighten the adjustment bolts 25-27 pound feet (34-37 newton meters).

5.11 Brake Adjustment (DC Only)



WARNING! Before performing service near moving parts such as blades, pulleys, motors, belts and chains, first turn the key switch to the OFF (#0) position and remove the key. If the key is turned on and moving parts activated, serious injury may result.



Check the brake pads for wear every 200 hours of operation. Replace if damaged or worn.

Also check and adjust the brake pads after each drive belt adjustment or if the blade does not stop quickly. Adjust the brake pads if the drive belt jumps from the drive pulley when the autoclutch is disengaged.

See Figure 5-11. The brake should be adjusted so the blade stops no more than 7 seconds after turning the blade switch off. Loosen the jam nuts around the adjustment turnbuckle and turn the turnbuckle to adjust the brake. Retighten the jam nuts. Multiple adjustments of the brake will affect engine RPM at idle. If you notice any change in the idle of the engine after adjusting the brake, check the RPM and adjust the throttle cable if necessary to allow the throttle plate to rest on the idle stop screw (See Engine manual).

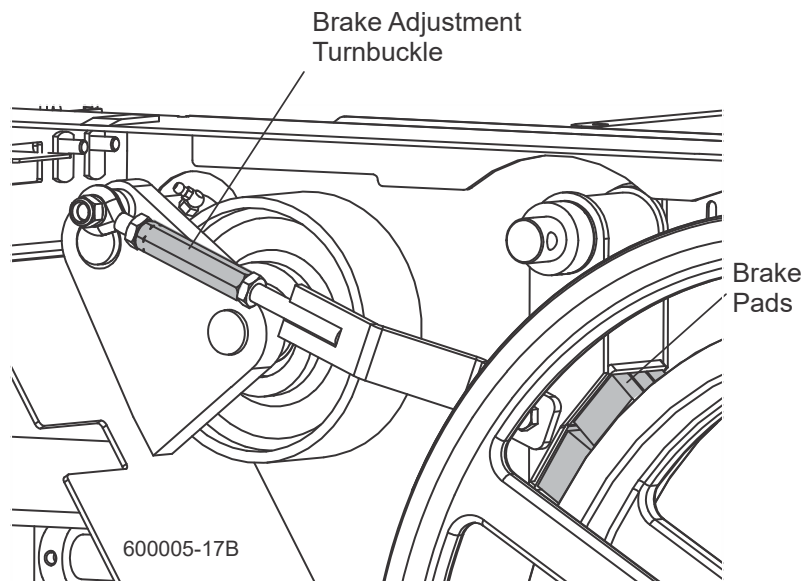

FIG. 5-11

5.12 Autoclutch Belt (DC Only)

See Figure 5-12. Tighten the clutch belt as necessary to prevent slippage.

Remove the two cover bolts and washers and remove the cover. Loosen the clutch motor mounting bolts and slide the motor up to tighten the belt. Tighten the belt to 1/16" deflection with 1/4 lb. deflection force. Wood-Mizer offers a belt tension gauge (Part No. 016309) that will let you accurately measure the belt tension.

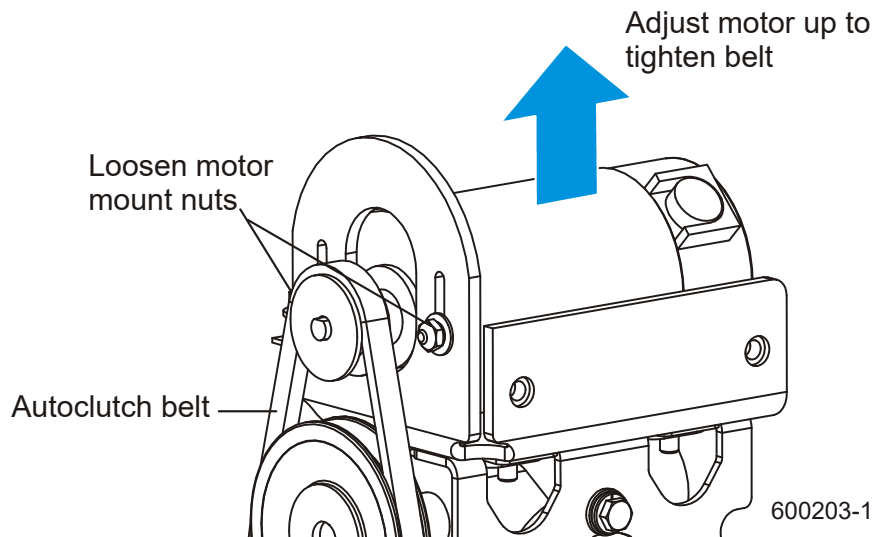

FIG. 5-12

Inspect the belt for wear or cracks and replace as necessary.

5.13 Hydraulic System



WARNING! Disconnect and lockout power before performing any service to the electrical system. For battery-powered equipment, disconnect the negative battery terminal cable. For AC-powered equipment, follow the lockout procedure provided in the safety section ([See Section 2.3](#)). Failure to do so may result in injury and/or electrical system damage.

1. Check the hydraulic fluid level every fifty hours of operation. Add fluid as necessary. The level in the hydraulic pump should be 3/4" (19mm) from the top with all cylinders collapsed.

If humidity is a problem or the mill is used outside in humid weather, drain and replace two quarts (.95 liters) of fluid every six months. This will drain any accumulated water and help prevent pump failure due to water ingestion. It also will prevent excessive fluid wear and allow the fluid to maintain its hot end performance. If humidity is not a problem, drain and replace one gallon (3.8 liters) of fluid every year to prevent fluid wear.

See Figure 5-13. If you are operating in temperatures -20° to 100° F (-29° to 38° C), use an all-weather hydraulic fluid such as Conoco MV32. For alternate fluids and/or other temperature ranges, refer to the chart below. Operating above the recommended temperature range of a fluid could result in excessive pump wear. Operating below the recommended temperature range could result in reduced hydraulic cylinder speed. To change fluid types, replace one gallon of the current fluid with one gallon of the alternate fluid.

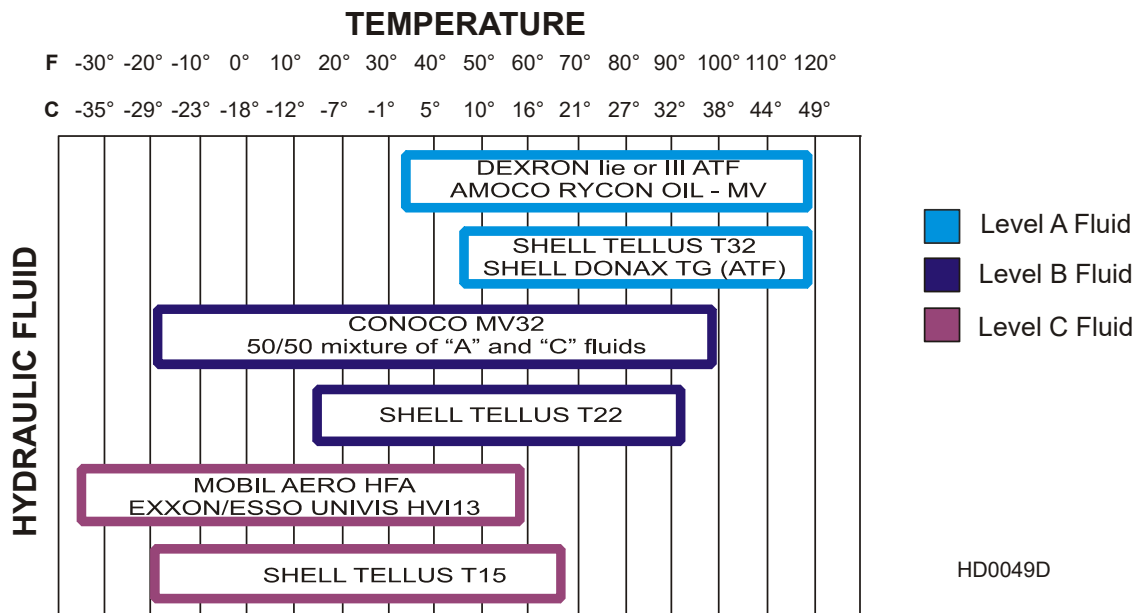

FIG. 5-13

2. Replace the hydraulic system cartridge filter every 500 hours of operation.

500

3. **DC Only:** Inspect the hydraulic pump motor brushes every 750 hours of operation. Remove brush dust and replace the brushes if they worn to a length of 1/4" (6mm) or shorter.

750





CAUTION! Do not operate the hydraulic system if the pump motor brushes are worn shorter than 1/4" (6mm). Damage to the pump motor may result.

4. Periodically check all hydraulic lines and fitting as needed. Replace as necessary.

5.14 Up/Down System

 **WARNING!** Before performing service near moving parts such as blades, pulleys, motors, belts and chains, first turn the key switch to the OFF (#0) position and remove the key. If the key is turned on and moving parts activated, serious injury may result.

 **WARNING!** Disconnect and lockout power before performing any service to the electrical system. For battery-powered equipment, disconnect the negative battery terminal cable. For AC-powered equipment, follow the lockout procedure provided in the safety section ([See Section 2.3](#)). Failure to do so may result in injury and/or electrical system damage.

 Adjust the up/down chain tension as needed. Measure chain tension with the head all the way to the top of the vertical mast. Secure the head with a chain at the top. Find the chain adjusting bolt at the bottom of the mast. Use the adjustment nut to adjust the bolt until the center of the chain can be deflected 3/4" (1.9cm) forward with a 5 lb. (2.3 Kg) deflection force.

 **WARNING!** Always secure the saw head with a 5/16" chain with at least 1900 lbs. working load capacity before adjusting the up/down chain. The cutting head may fall, causing severe injury or death.

 **CAUTION!** Do not over-tension the chain. Over-tensioning the chain may lead to early failure of the gear reducer.

See Figure 5-14.

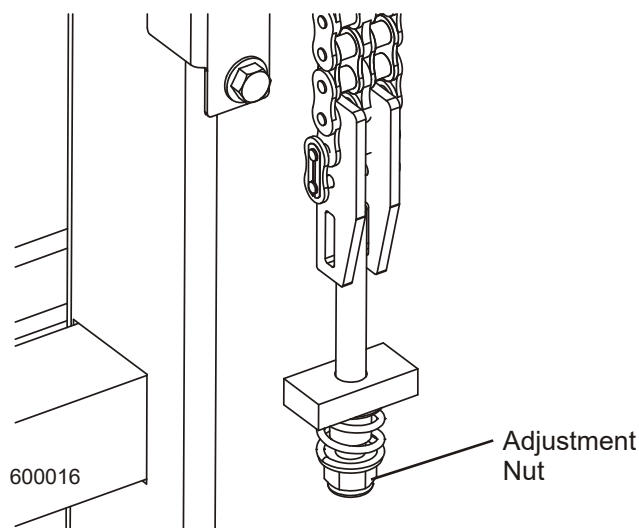

FIG. 5-14

5. The up/down motor features a spring-loaded belt design. Belt tension is automatically maintained and requires no adjustment. Replace the belt when adequate belt tension can no longer be obtained.



WARNING! Always secure the saw head with a 5/16" chain with at least 1900 lbs. working load capacity before removing the up/down motor belt. The cutting head may fall, causing severe injury or death.

AR

Periodically check the belt for wear. Replace any damaged or worn belts as needed.

6. Check the up/down gearbox oil level. Add a synthetic gear oil such as Mobil Glygoyle 460 as needed.

Drain and refill the gearbox with 40 (1.2L) ounces of oil after every 5000 hours of sawmill operation or every year, whichever comes first.

Wood-Mizer offers replacement gear oil in 8 ounce (0.24L) bottles.

7. Inspect the up/down motor brushes every 750 hours of operation. Remove brush dust and replace the brushes if they worn to a length of 5/8" (16mm) or shorter.

750



CAUTION! Do not operate the up/down system if the motor brushes are worn shorter than 5/8" (16mm). Damage to the up/down motor may result.

AR

The up/down system is equipped with a gas spring assist mechanism to provide improved speed and performance. The saw head must be secured and tension released from the assist assembly before performing any maintenance to assist components.

8



WARNING! Always secure the saw head with a 5/16" (8mm) chain with at least 1900 lbs. (860Kg) working load capacity before servicing the up/down assist. The cutting head may fall, causing severe injury or death.



WARNING! Release pressure from the up/down assist prior to performing any service to the assembly. Failure to do so may result in the assembly flying apart, causing injury or damage to the equipment.

5 Maintenance

Up/Down System

1. Locate the four upper up/down assist mounting bolts. Remove the two lower set of mounting bolts.

See Table 5-3.

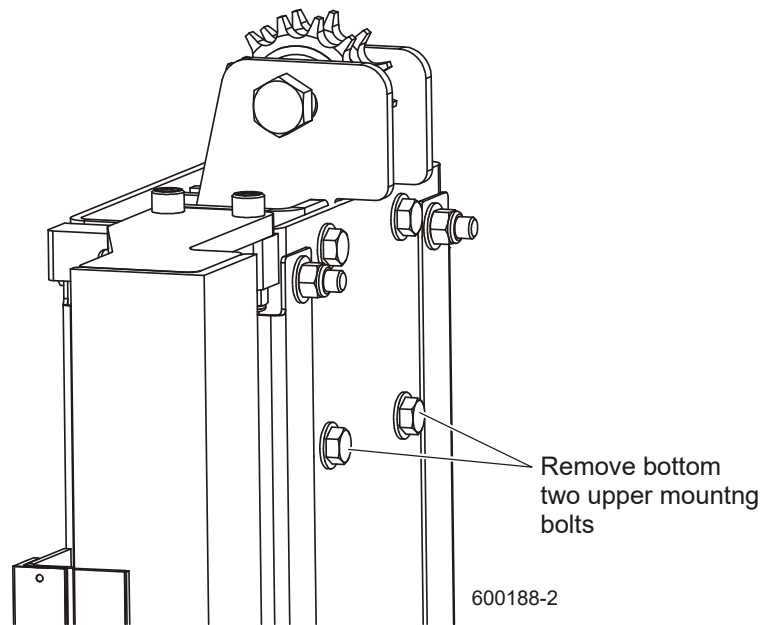

FIG. 5-14

2. Raise the saw head all the way to the top of the mast and secure with a chain.
3. Locate the up/down assist tension assembly.

See Figure 5-15.

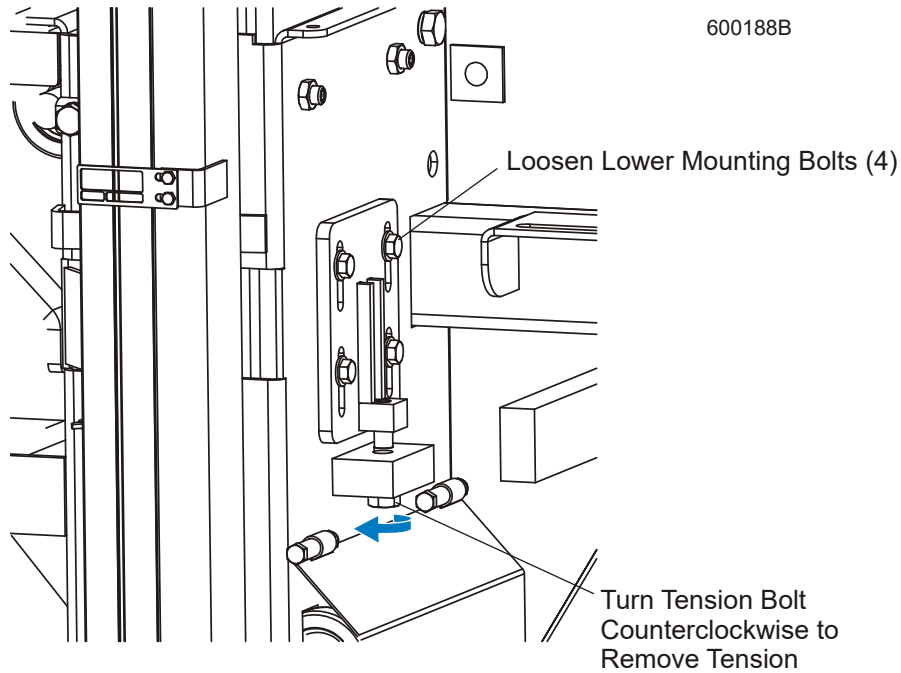

FIG. 5-15

4. Loosen (do NOT remove) the four lower mounting bolts to allow the bracket to move along the slotted mounting holes.
5. Turn the tension bolt counterclockwise to remove tension from the up/down system. Turn the bolt until it disengages from the mounting plate assembly.
6. Remove the four lower mounting bolts and lift the mounting plate to access the up/down chain. Disassemble the master link securing the chain to the saw head.

See **Figure 5-16**. Secure the chain at the top of the assist assembly to prevent it from falling down into the tube.

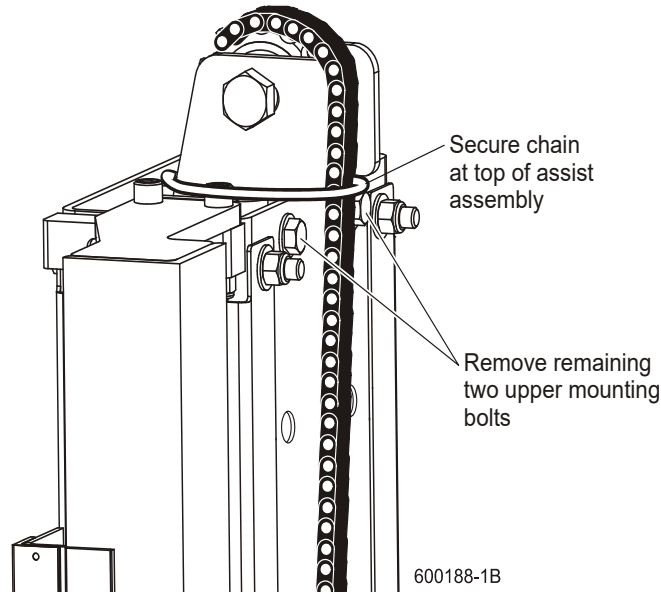

FIG. 5-16

7. Remove the two remaining upper mounting bolts at the top of the assist assembly and lift the assembly from the mast tube.

NOTE: The assist assembly weighs approximately 70 lbs (32Kg). It is recommended two people lift the assembly from the mast. A hoist or some other mechanical method may also be used.

8. Once the assist assembly is removed, components may easily be disassembled and serviced as needed. Do not disassemble the gas spring cylinders.



WARNING! The gas spring cylinders are pressurized. Disassembly of cylinder may result in injury or damage to the cylinder.

9. When service is complete, reinstall the assist assembly in the reverse order of the disassembly procedure. Reattach the chain with the master link. Replace the lower mounting bracket and bolts (do not tighten bolts yet). Tighten the tension bolt until the end of the bolt is flush with the top of the threaded block of the mounting plate. Tighten the mounting bolts.

5.15 Power Feed



WARNING! Before performing service near moving parts such as blades, pulleys, motors, belts and chains, first turn the key switch to the OFF (#0) position and remove the key. If the key is turned on and moving parts activated, serious injury may result.



WARNING! Disconnect and lockout power before performing any service to the electrical system. For battery-powered equipment, disconnect the negative battery terminal cable. For AC-powered equipment, follow the lockout procedure provided in the safety section ([See Section 2.3](#)). Failure to do so may result in injury and/or electrical system damage.

1. Adjust the power feed chain as needed. Measure the power feed chain tension with the saw head all the way toward the rear of the mill. Use the adjustment nut on the feed tensioner at the front of the mill to tighten or loosen the power feed chain. Adjust the chain until it measures 7 to 8 inches (17.8 to 20.3 cm) from the top of the top rail at its lowest point.



CAUTION! Do not overtighten the feed chain. Damage to the power feed motor may result.

See Figure 5-17.

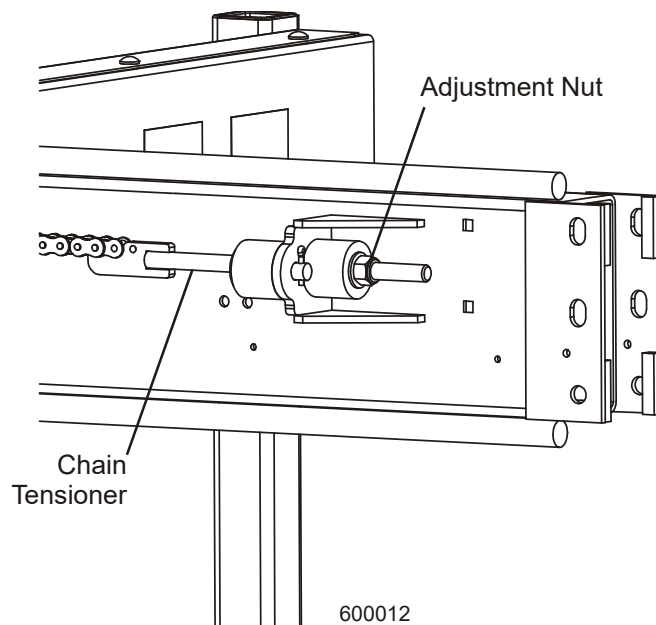

FIG. 5-17

Refer to the diagram for power feed chain routing instructions.

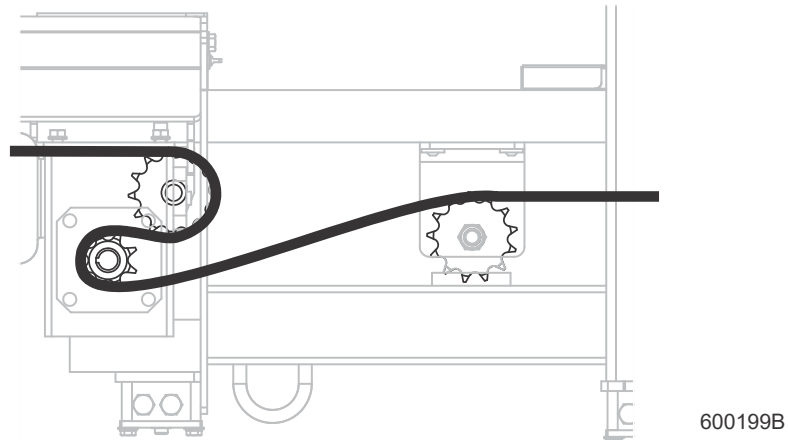

FIG. 5-17

2. Inspect the power feed motor brushes every 750 hours of operation. Remove brush dust and replace the brushes if they worn to a length of 5/8" (16mm) or shorter.

750



CAUTION! Do not operate the power feed system if the feed motor brushes are worn shorter than 5/8" (16mm). Damage to the feed motor may result.

3. Check the power feed gearbox oil level. Add a synthetic gear oil such as Mobil Glygoyle 460 as needed.

Drain and refill the gearbox with 12 - 15 ounces (0.35 - 0.44L) of oil after every 5000 hours of sawmill operation or every 2 years, whichever comes first.

Wood-Mizer offers replacement gear oil in 8 ounce (0.24L) bottles.

5.16 Charging The Battery (DC Only)

 **DANGER!** Batteries expel explosive gases. Keep sparks, flames, burning cigarettes, or other ignition sources away at all times. Always wear safety goggles and a face shield when working near batteries. Failure to do so will cause serious injury.¹

 **WARNING!** Battery posts, terminals and related accessories contain lead and lead compounds, chemicals known to the State of California to cause cancer and reproductive harm. Wash hands after handling.

 **WARNING!** Charge the battery in a well ventilated area. Do not attempt to charge a frozen battery.

Use extreme care to avoid spilling or splashing electrolyte (which is dilute sulfuric acid) as it can destroy clothing and burn the skin.

EMERGENCY TREATMENT FOR CONTACT WITH BATTERY COMPONENTS (LEAD/SULFURIC ACID) per SDS (Safety Data Sheet):

EYE CONTACT	Sulfuric Acid and Lead: Flush eyes immediately with large amounts of water for at least 15 minutes while lifting lids. Seek immediate medical attention if eyes have been exposed directly to acid.
SKIN CONTACT	Sulfuric Acid: Flush affected area(s) with large amounts of water using deluge emergency shower, if available, shower for at least 15 minutes. Remove contaminated clothing, including shoes. If symptoms persist, seek medical attention. Wash contaminated clothing before reuse. Discard contaminated shoes. Lead: Wash immediately with soap and water.
INGESTION	Sulfuric Acid: Administer large amounts of water. Do NOT induce vomiting or aspiration into the lungs may occur and can cause permanent injury or death; consult physician.
INHALATION	Sulfuric Acid: Remove to fresh air immediately. If not breathing, give artificial respiration. If breathing is difficult, give oxygen. Consult a physician. Lead: Remove from exposure, gargle, wash nose and lips; consult physician.

If electrolyte is spilled or splashed on any surface of the machine, it should be neutralized and rinsed with clean water.

 **CAUTION!** Do not overcharge the battery. Overcharging may reduce the overall service life of the battery.

CAUTION! Be sure the battery is fully charged before transporting the sawmill. If the battery is not fully charged, excessive vibration could reduce the overall service life of the battery.

¹.Battery Council International, copyright 1987

5

Maintenance

Charging The Battery (DC Only)

1. Raise the saw head to access the battery box.
2. Turn the key to the OFF (#0) position and remove the key.
3. Remove the two wing nuts and flat washers holding the battery box lid to the battery box.
4. Remove the battery box lid.
5. Clean the battery terminals if necessary.
6. Connect the positive charger/jumper cable directly to the positive battery terminal.
7. Connect the negative charger/jumper cable to a grounded metal surface.
8. Follow the instructions supplied with your specific battery charger.



IMPORTANT: Be careful not to overcharge the battery, especially when using a high-rate or “boost” charger (40 amps or higher). These are intended to quickly charge a good battery that is discharged. They are not intended for unattended or long-term charging.

9. After the battery is completely recharged, remove the negative charger/jumper cable from ground.
10. Remove the positive charger/jumper cable from the battery.
11. Replace the battery box lid and replace the flat washers and wing nuts.

5.17 Turner Chain Tension



WARNING! Before performing service near moving parts such as blades, pulleys, motors, belts and chains, first turn the key switch to the OFF (#0) position and remove the key. If the key is turned on and moving parts activated, serious injury may result.



Adjust the turner chain tension as necessary to keep the turner operating properly. If the chain becomes too loose, the log will catch on the support bracket and not turn.

See Figure 5-18. To adjust the chain tension, loosen the clamping bolt nut and the jam nut on the adjustment bolt. Turn the adjustment bolt counterclockwise to tighten the chain until it is aligned with the curved portion of the support bracket. Retighten the jam nut and the clamping bolt nut.

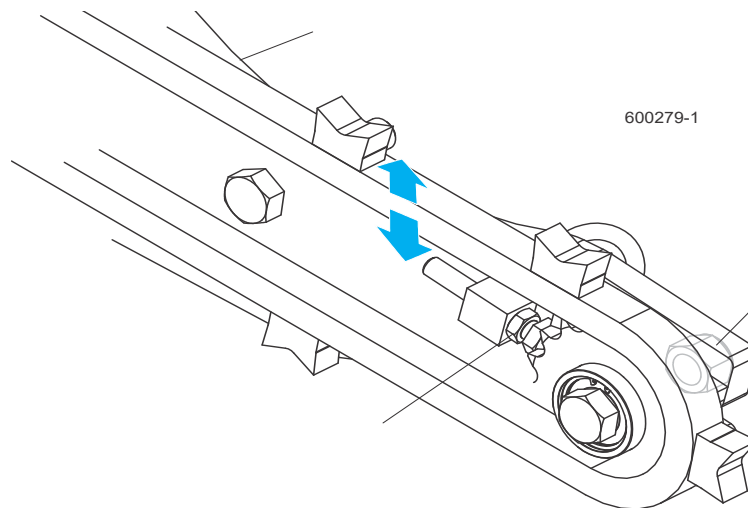

FIG. 5-18

5.18 Maintenance chart

MAINTENANCE LOG (Check <i>Engine And Option Manuals</i> for additional maintenance procedures)	MANUAL REFERENCE	MAINTENANCE INTERVAL
Clean sawdust from hydraulic loader fuses , battery box lid & track cover	See Section 5.3	8 hours
Clean and lubricate top/bottom track	See Section 5.4	8 hours
Check blade guide Block/roller wear	See Section 5.2	8 hours Every blade change
Remove excess sawdust from blade wheel housings and sawdust chute	See Section 5.3	8 hours Every blade change
Inspect fingers inside sawdust chute	See Section 5.3	8 hours Every blade change
Remove sawdust from upper track roller housings	See Section 5.4	25 hours
Check Blade Guide Block Spacing	See Section 5.2	25 Hours
Clean and lubricate upper track wiper	See Section 5.4	25 hours
Clean & lube mast rails	See Section 5.5	50 hours
Lubricate drum switches	See Section 5.6	50 hours
Grease pivot points and bearings/oil chains	See Section 5.7	50 hours
Rotate drive/idle blade wheel belts/check for wear	See Section 5.9	50 hours
Inspect hydraulic lines & fittings	See Section 5.13	50 hours
Check belt tensions	See Section 5.10 See Section 5.14	50 hours
Check hydraulic fluid level	See Section 5.13	50 hours
Check feed & up/down chain tensions	See Section 5.14 See Section 5.15	50 hours
Check up/down & power feed gear box fluid levels	See Section 5.14 See Section 5.15	50 hours
Check brake pads	See Section 5.11	200 hours
Re-check belt tensions	See Section 5.10 See Section 5.14	200 hours
Check blade throat screw	See Section 5.2	500 hours
Replace hydraulic system filter	See Section 5.13	500 hours
Inspect hydraulic pump, power feed and up/down motor brushes	See Section 5.13 See Section 5.14 See Section 5.15	750 hours

SECTION 6 TROUBLESHOOTING GUIDE

6.1 Sawing Problems



WARNING! Before performing service near moving parts such as blades, pulleys, motors, belts and chains, first turn the key switch to the OFF (#0) position and remove the key. If the key is turned on and moving parts activated, serious injury may result.

PROBLEM	CAUSE	SOLUTION
Blades Dull Quickly	Dirty logs	Clean or debark logs, especially on entry side of the cut
	When grinding teeth, heating too much and causing teeth to soften	Grind just enough metal to restore sharpness to the teeth. Use water/coolant while sharpening blade
	Poor sharpening techniques	Make sure the tip is being sharpened completely (See Sharpener Manual)
Blades Break Prematurely	Poor sharpening techniques	See Sharpener Manual
	Tension too tight	Tension blade to recommended specifications
Blade Does Not Track Right on Drive Wheel	Cant adjustment is incorrect	Readjust
Drive Belts Wear Prematurely or Jump	Engine/motor and drive pulleys out of alignment	Align pulleys See Section 6.9.
Boards Thick Or Thin On Ends Or Middle Of Board.	Stress in log which causes log to not lay flat on the bed.	After log has been squared, take equal cuts off opposing sides. Take a board off the top. Turn the log 180 degrees. Take a board off. Repeat, keeping the heart in the middle of the cant, and making it your last cut.
	Set in teeth.	Resharpen and reset blade.
	Bed rails misaligned.	Realign sawmill.
Height Adjustment Jumps or Stutters When Moving Up or Down.	Up/down chain improperly adjusted.	Adjust up/down chain.
	Up/down belt loose.	Replace belt.
Lumber Is Not Square	Vertical side supports not square to bed	Adjust side supports.
	Blade not parallel to bed rails	Adjust bed rails parallel to blade.
	Sawdust or bark between cant and bed rails	Remove particles

6

Troubleshooting Guide*Sawing Problems*

PROBLEM	CAUSE	SOLUTION
	Tooth set problems	Resharpener and reset blade
Sawdust Builds Up On Track	Excessive oiling	Do not oil track
	Track wipers worn	Adjust wipers to firmly contact track
	Track is sticky	Clean track with solvent and apply silicone spray
Wavy Cuts	Excessive feed	Slow feed rate
	Improperly sharpened blade (This will be the problem 99% of the time!)	Resharpener blade (See Sharpener Manual - read entire manual!)
	Blade guides improperly adjusted	Adjust blade guides.
	Sap buildup on blade	Use Water Lube.
	Tooth set problem	Resharpener and reset blade

6.2 Electrical Problems



WARNING! Before performing service near moving parts such as blades, pulleys, motors, belts and chains, first turn the key switch to the OFF (#0) position and remove the key. If the key is turned on and moving parts activated, serious injury may result.



WARNING! Disconnect and lockout power before performing any service to the electrical system. For battery-powered equipment, disconnect the negative battery terminal cable. For AC-powered equipment, follow the lockout procedure provided in the safety section ([See Section 2.3](#)). Failure to do so may result in injury and/or electrical system damage.

PROBLEM	CAUSE	SOLUTION
Up/down Excessively Slow.	Up/down belt loose.	Adjust belt to be as loose as possible without slipping.
	Worn up/down motor or motor brushes.	Replace up/down motor or motor brushes.
Up/down Or Power Feed Motors Do Not Work.	Worn/dirty contacts in drum switch.	Replace switch or remove control panel cover and clean contacts.
	Bad key switch.	Replace key switch.
	Circuit breaker.	Reset breaker in control box (See Section 6.3).
	Burned-out motor.	Replace motor.
Power Feed Motor Does Not Work.	Bad connection on battery post or loose wire.	Check for loose wire or terminal connections.
	Sawdust buildup in the power feed pulleys.	Sawdust buildup puts mechanical bind on power feed which causes automatic motor protection circuit to activate. Remove sawdust from pulleys and operate normally. If motor does not operate after sawdust removal, reset circuit breaker on the front of the control box.
Up/Down Or Power Feed Switches Remain Engaged When Switch Is Released.	Worn/dirty contacts in drum switch.	Manually move the power feed or up/down switch back to neutral or "off" position. Replace drum switch or remove control panel cover and clean and lubricate contacts NOTE: Use only contact grease supplied by Wood-Mizer.
	Drum switch spring broken.	Manually move the power feed or up/down switch back to neutral or "off" position. Replace drum switch spring.

6

Troubleshooting Guide*Electrical Problems*

PROBLEM	CAUSE	SOLUTION
Up/Down Or Power Feed Motors Overheat And Lose Power.	System overload or bind occurred.	Correct problem (See Section 6.4). Allow motor to cool before restarting.
	Normal operation factors exceeded (eg: up/down control jockeyed excessively).	Allow motor to cool before restarting.
Everything Works And Then Cuts Out - Works Again.	Bad battery, fuse, or ground connection.	Check and tighten connections.
Nothing Works Electrically.	Dead battery.	Check for short circuit or turn OFF key.
	Blown fuse.	Replace.
	Corrosion on battery post.	Remove connection and clean posts.
Battery Will Not Stay Charged.	Key switch left ON.	Turn switch OFF when not in use.
	Short in system.	Visually check for bare wires and/or have checked.
	Charging system not functioning.	Have charging system checked by authorized dealer.
	Bad battery cells.	Check fluid levels and add proper solution
Intermittent Or Permanent Loss Of Accessory Motor Functions Occurs (Up/down, Fwd/rev, Blade Guide Functions Do Not Work).	Idle improper.	Adjust low end RPM per engine manual.
	Loose alternator belt.	Check belt tension and tighten if necessary.
	Loose connections at LED circuit board or alternator.	Check and tighten connections.
	Bad connections at accessory solenoid or bad solenoid.	Check all connections at accessory solenoid. If connections are good, replace solenoid.

6.3 Circuit Breaker Operation

Sawmill controls are equipped with manual reset circuit breakers to protect the electrical circuits.

DC Models Only: The power feed and up/down breakers are externally mounted at the front of the control box. An external breaker is provided on the rear of the control box for the engage sensor circuit on sawmills equipped with diesel engines or autoclutch. The blade guide, accessory, ignition and start breakers are located inside the control box. Remove the circuit breaker panel from the control box to access the internal breakers.

NOTE: If the breaker is still hot, you may not be able to reset it immediately. Allow the breaker to cool for a few minutes before attempting to reset.

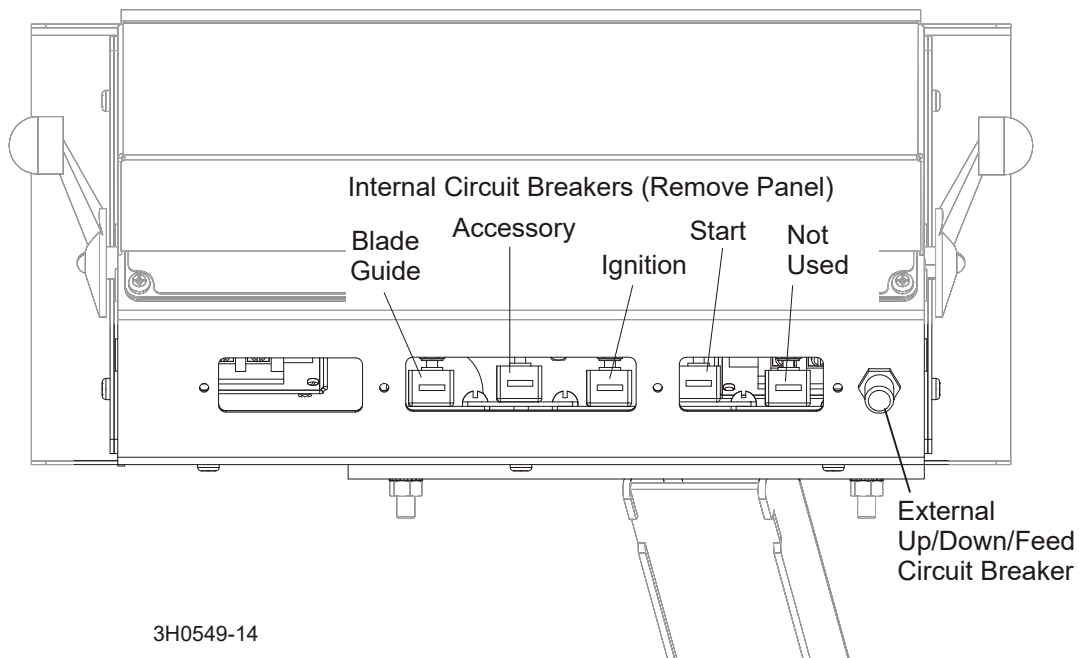

FIG. 6-0

See Figure 6-1. AC Models Only: The hydraulic, ignition, start and blade guide breakers are located inside the control box. Remove the circuit breaker panel from the control box to access the internal breakers.

6 Troubleshooting Guide
Circuit Breaker Operation

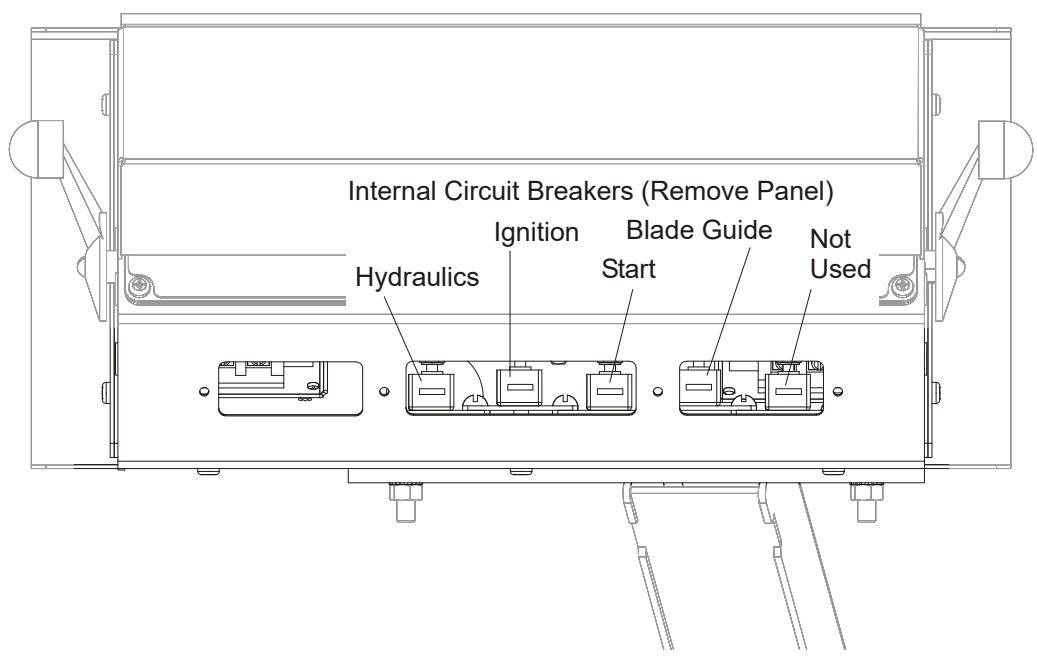

FIG. 6-1 AC MODELS ONLY

6.4 Power Feed Problems



WARNING! Disconnect and lockout power before performing any service to the electrical system. For battery-powered equipment, disconnect the negative battery terminal cable. For AC-powered equipment, follow the lockout procedure provided in the safety section ([See Section 2.2](#)). Failure to do so may result in injury and/or electrical system damage.

NOTE: The Dual-Axis Control is equipped with LED lights to help determine the cause of any feed problems you may encounter. [See Accuset 2 option manual](#) for instructions.

PROBLEM	CAUSE	SOLUTION
Power Feed Is Jerky At Low Speeds Or Does Not Move Until Speed Is Above Halfway Mark.	Drum switch is dirty.	Clean drum switch and lubricate with contact grease supplied by Wood-Mizer.
	Drum switch contacts are bad	Check that contacts are in good condition and positively close circuit.
	Components are loose or wires are broken.	Replace or repair PC board.
Power Feed Is Jerky When Shaft Of Feed Rate Dial Is Moved Back And Forth.	Variable speed switch is bad - perform the variable speed switch test.	Replace variable speed switch.
Power Feed Is Jerky, But Power Feed Motor Runs Properly At All Speeds.	Problem is mechanical.	Refer to the Mechanical Test.
Power Feed Motor Overheats.	Middle track oiler is dragging.	Clean middle track oiler and lubricate with 30-weight oil or ATF (Automatic Transmission Fluid) such as Dexron II. Allow motor to cool before restarting.
	Ground is not level.	Level mill with carpenter's level. Allow motor to cool before restarting.
	Track roller bearing drag is excessive.	Lubricate bearings; Replace tight bearings. Allow motor to cool before restarting.
	Lower track rollers are not aligned properly.	Check stop clearance from lower track rail. Allow motor to cool before restarting.

6

Troubleshooting Guide*Power Feed Problems*

PROBLEM	CAUSE	SOLUTION
	Chain is dragging.	Make sure chain is centered on idler; Clean and lubricate chain; Adjust chain tension. Allow motor to cool before restarting.
	Chain is improperly tensioned.	Adjust chain tension. Allow motor to cool before restarting.
	Operator Seat option load is excessive.	Check seat bearings for freedom of movement; Loosen clamping screw 1/4 turn. Allow motor to cool before restarting.
	Power feed is binding.	Adjust belt tension; Check condition of belt, pulleys, bearings, and sprocket; Check motor for ground fault. Allow motor to cool before restarting.
	Saw head load is excessive.	Avoid unnecessary modifications to saw heads that would give them extra weight. Allow motor to cool before restarting.
	Blade is dull or improperly set.	Use proper blade maintenance procedures (See Sharpener or Toothsetter manual). Allow motor to cool before restarting.

6.5 Power Feed Variable Feed Rate Switch Test

With the feed rate dial switch all the way down, move the shaft of the dial back and forth to see if there is a jerky response. Turn the dial and move the shaft back and forth again. Repeat several times. If the jerkiness occurs at the same location on the dial several times, you need to replace the variable speed switch.



WARNING! Disconnect and lockout power before performing any service to the electrical system. For battery-powered equipment, disconnect the negative battery terminal cable. For AC-powered equipment, follow the lockout procedure provided in the safety section ([See Section 2.3](#)). Failure to do so may result in injury and/or electrical system damage.

6.6 Power Feed Mechanical Test

1. Remove the weight from the track rollers. They should turn smoothly and easily with very little play.
2. Make sure the middle track cover is not bent or touching the top rail.
3. Make sure the middle track oiler is free of sawdust buildup.
4. Make sure the power feed chain is not stiff from rust. Also make sure the chain is not too tight.
5. Make sure there is no sap or rust on the rails.
6. Make sure the stop on the lower track roller assembly is not rubbing the lower rail. Also make sure the track rollers are not too tight.

6.7 Hydraulic Problems



WARNING! Disconnect and lockout power before performing any service to the electrical system. For battery-powered equipment, disconnect the negative battery terminal cable. For AC-powered equipment, follow the lockout procedure provided in the safety section ([See Section 2.3](#)). Failure to do so may result in injury and/or electrical system damage.



WARNING! Before performing service near moving parts such as blades, pulleys, motors, belts and chains, first turn the key switch to the OFF (#0) position and remove the key. If the key is turned on and moving parts activated, serious injury may result.

PROBLEM	CAUSE	SOLUTION
You Can Actuate Any Hydraulic Handle, But Get No Response From The Pump.	Carriage not positioned properly to provide power to the pump	Make sure carriage contact bracket is adjusted far enough forward for battery positive contact to touch 6ft. strip on main tube. Check contact and strip for tarnish or loose wires. Clean as necessary
	Poor ground connection	Check ground connection between pump and saw frame and between battery negative contact and lower rail. Check contact and rail for tarnish or loose wires. Clean as necessary
	Blown fuse	Replace
	Low or dead battery	Test battery amperage capability (such as low battery charge, low alternator output, defective voltage regulator, bad battery cell, battery age deterioration, etc.). Replace or recharge as necessary
	Poor cable connection	Check cable connection and make sure that battery terminals are in good condition (not corroded)
	Defective solenoid (may be indicated by solenoid clicking) See Monarch manual for troubleshooting solenoid	After checking all other possibilities for low voltage to solenoid, check solenoid. Tapping on solenoid may fix temporarily. Replace solenoid if necessary. NOTE: The solenoid is not a standard automotive type. Order from Wood-Mizer only
	Defective pump motor	Remove motor from pump and inspect. Repair or replace as necessary

PROBLEM	CAUSE	SOLUTION
You Can Get Response From the Pump By Actuating All But One or Two Handles	Valve assembly switch contacts are not properly adjusted	Locate the valve switch at the bottom of the valve assembly. Use a 3MM allen wrench to loosen the set screw on each of the five switch contacts. Press each contact to the valve block and tighten the contact set screw to secure in place. CAUTION! Do not overtighten! NOTE: Do not adjust the valve switch or switch spring; they have been preset at the factory.
Pump Motor Runs With Little Or No Response From The Cylinders	Low battery	Test battery. Recharge or replace as necessary
	Low fluid level	Check fluid level. Add an all-season hydraulic fluid such as Amoco Rycon Oil MV or Mobil Multipurpose ATF (automatic transmission fluid) until level is 4 - 4 1/2" (100 - 114mm) from bottom of reservoir with all cylinders retracted
	Pressure relief valve moved from proper setting	Adjust pressure relief valve.
	Low air temperature causing fluid to thicken	Allow fluid to warm up. Synthetic fluids are available that allow for hydraulic operation in cold weather conditions (Univis HVI 13)
Pump Motor Runs Continuously When Power Contact Is Made	Solenoid is stuck closed	Tapping the solenoid may solve this problem temporarily. Replace solenoid
Fluid Leaks From Around Cylinder Piston Ram	Worn seals	Replace seals in cylinder. Check piston ram for abrasive weld that may be causing premature seal failure
Fluid Leak Around Pump Box	Loose seal or fitting	Wipe pump off completely to locate cause of leak. You may have to unbolt the pump to wipe behind it. NOTE: Movement of the sawmill can cause fluid to slosh up into the foam filter in the reservoir cap, and subsequently spray out, giving the appearance that fluid is leaking from the pump
Hydraulic Side Supports Go Down Before Or At Same Time As Log Turner	Dirt in sequence valve	Remove sequence valves and clean thoroughly with kerosene. NOTE: Be sure to reassemble the valve and install it in its original position on the cylinder
	Retainer in sequence valve worn	Replace sequence valve

PROBLEM	CAUSE	SOLUTION
	Low air temperature causing fluid to thicken	Allow fluid to warm up. Synthetic fluids are available that allow for hydraulic operation in cold weather conditions (Univis HVI 13)
Hydraulic Turner Goes Up Before Or At Same Time As Side Supports	Dirt in sequence valve	Remove sequence valves and clean thoroughly with kerosene. NOTE: Be sure to reassemble the valve and install it in its original position on the cylinder
	Retainer in sequence valve worn	Replace sequence valve
	Low air temperature causing fluid to thicken	Allow fluid to warm up. Synthetic fluids are available that allow for hydraulic operation in cold weather conditions. (Univis HVI 13)
Hydraulic Toe Boards "Creep" UP OR DOWN without the valve control handles being operated OR do not raise or lower at all..	Can be a result of shock load caused by improperly using the toe boards to "cushion" or break the fall of a cant onto the bed): · damaged hoses · damaged cylinder seals or cylinder · damaged valve	INITIAL CHECK To check, disconnect the toe board hydraulic hose from its current valve section and temporarily connect it to another valve section. Check to see if the hydraulics operate properly.
		If hydraulics operate properly , hoses and cylinder seals are good. Perform further valve inspection, found below. If creep still occurs , check all hoses for possible pinholes causing leakage. Replace if applicable. Retest. If creep still occurs , replace cylinder seals or cylinder and retest. Be sure to reconnect the hose to the proper valve section when done.
		FURTHER VALVE INSPECTION If further inspection of the valve is required after initial check, remove the check valve shown below. Flush the check valve with an air hose or solvent to remove any dirt from the valve's seat. Reinstall and test again. Check to see if the hydraulics operate properly. If creep still occurs , replace the check valve with a new one. Retest. If creep still occurs , replace the hydraulic valve.

6

Troubleshooting Guide*Hydraulic Problems*

PROBLEM	CAUSE	SOLUTION
	Bad check valve (results in one of the toe boards experiencing down-creep)	Check the release valve as instructed above. If the release valve is good, replace the high-pressure hydraulic check valves (A12869) located on the pump.
Pump runs but makes “growling” sound and hydraulic functions are slow, jerky or don’t work at all.	Low fluid level	Check fluid level and add fluid as necessary. Check for leaks in the system at the control box fittings, hoses and cylinders
One of the log loader cylinders does not move when lowering the loader causing the foot of other to raise completely before loader will start down.	Damaged cylinder shaft	Replace the cylinder that is not moving

6.8 Hydraulic Pressure Test

TO CHECK HYDRAULIC PRESSURE:

See Figure 6-2.

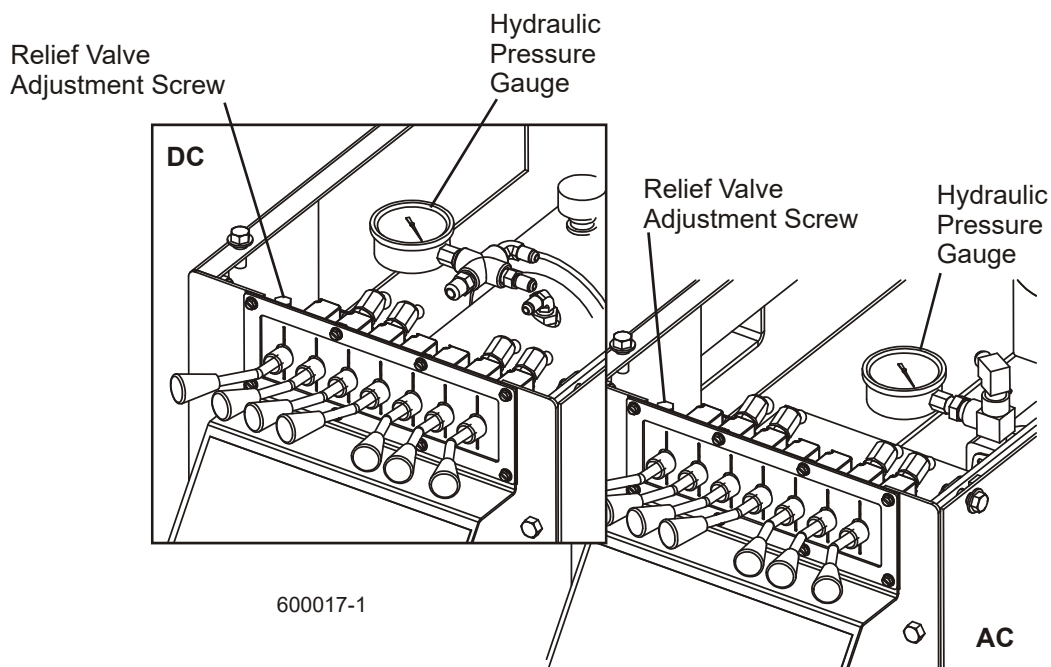

FIG. 6-2

Operate the loading arm hydraulic lever and read the pressure on the gauge. Hydraulic pressure is factory-set at 2200 psi and should not need to be readjusted. The relief valve adjustment screw shown may be used to fine-tune the hydraulic pressure:

Remove the adjustment screw nut. Tighten the adjustment screw (clockwise) to increase pressure. Loosen the adjustment screw (counterclockwise) to lower pressure.



CAUTION! Pressure should not exceed 2200 psi. If it does, the amp draw will rise above the design maximum of 200 amps, and could cause battery and system problems. Pressure above 2200 psi may also damage the hydraulic hoses.

6.9 Engine/Motor and Drive Pulleys Alignment



WARNING! Before performing service near moving parts such as blades, pulleys, motors, belts and chains, first turn the key switch to the OFF (#0) position and remove the key. If the key is turned on and moving parts activated, serious injury may result.



WARNING! Do not for any reason adjust the engine drive belts or belt support bracket with the engine running. Doing so may result in serious injury.

1. Install and properly tension the drive belt ([See Section 5.10](#)).
2. With the autoclutch disengaged, use a straight edge to check the alignment of the pulley on the engine/motor to the alternator pulley. Loosen the bushing on the engine/motor pulley and adjust if necessary until it is aligned with the alternator pulley.
3. With the autoclutch disengaged, use a straight edge to check the alignment of the engine/motor pulley to the main drive pulley. Loosen the bushing on the drive pulley and adjust if necessary until it is aligned with the engine/motor pulley.
4. **(E25/E30 Only):** Check that the engine/motor pulley is also square with the drive pulley. If necessary, loosen the engine mounting bolts and cock the engine until the pulley is square with the drive pulley. Retighten the engine mounting bolts.
5. Check that all engine mounting bolts and pivot bushing clamps are tight.
6. Engage the autoclutch and recheck the pulley alignment. Adjust if necessary.
7. If any pulleys were adjusted, recheck the drive belt support(s) and adjust if necessary ([See Section 5.10](#)).

SECTION 7 SAWMILL ALIGNMENT

The Wood-Mizer sawmill is factory aligned. Two alignment procedures are available to realign the sawmill if necessary. The Routine Alignment instructions should be performed as necessary to solve sawing problems not related to blade performance. The Complete Alignment procedure should be performed approximately every 1500 hours of operation (sooner if you regularly transport the sawmill over rough terrain).

7.1 Routine Alignment Procedure

Blade Installation

1. Remove the blade and check the blade wheel belts. Remove any sawdust buildup from the surface of the belts. Replace worn belts if they do not keep the blade from contacting the blade wheel.
2. Install a clean blade and apply the appropriate tension ([See Section 3.4](#)).
3. Inspect the blade guide blocks for damage or wear and replace as necessary. Check the blade guide blocks and drive side deflector plate are properly adjusted ([See Section 5.2](#)).
4. Adjust the idle-side cant control to track the blade ([See Section 3.5](#)).
5. Close the blade housing covers and make sure all persons are clear of the saw head.
6. Start the engine (or motor).
7. Engage the blade, rotating the blade until the blade positions itself on the wheels.



WARNING! Do not spin the blade wheels by hand. Spinning the blade wheels by hand may result in serious injury.

8. Disengage the blade. Turn the engine off and remove the key.

Saw Head Tilt

As the blade enters a wide log or cant, the outside of the saw head will drop down slightly. To compensate for the drop, the saw head is adjusted 1/16" (1.5 mm) higher at the outside.

1. Move the saw carriage so the blade is positioned over a bed rail. Adjust the blade guide arm to 1/2" (15 mm) from full open.
2. Raise the saw head so the bottom of the blade measures 14 3/4" (375 mm) from the top surface of the bed rail near the inner blade guide assembly.

7 Sawmill Alignment

Saw Head Tilt

See Figure 7-1.

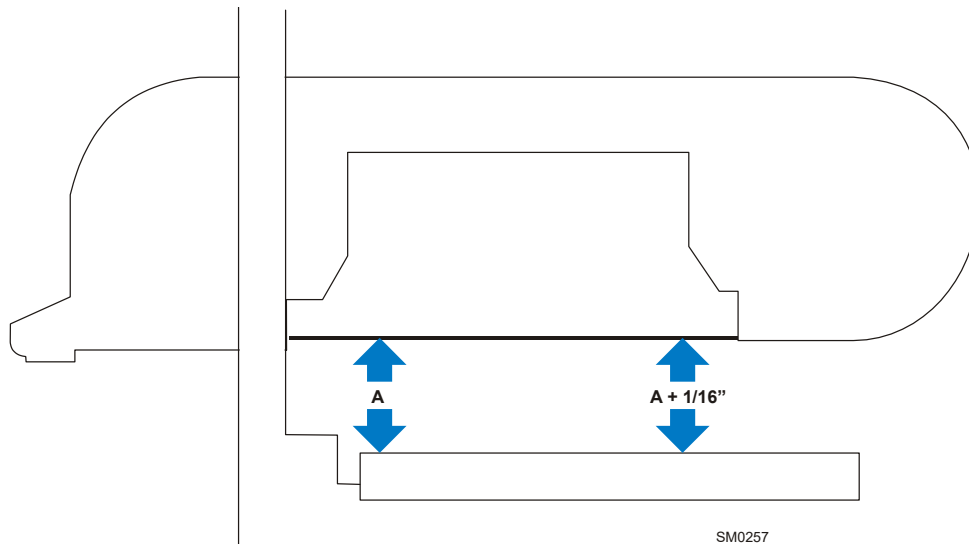

FIG. 7-1

3. Measure from the blade to the bed rail near the outer blade guide assembly. This measurement should be $1/16"$ (1.5 mm) higher than the inner measurement or $14 \frac{13}{16}"$ (376.5 mm).

See Figure 7-2. To adjust the saw head tilt, use the bolts located at the bottom of the saw head mast. Loosen the three sets of four retaining plate bolts. To raise the outside of the saw head, back the stop bolts out, then tighten the adjustment bolts. To lower the outside of the saw head, loosen the adjustment bolts and tighten the stop bolts. Recheck the measurement from the blade to the bed rails and adjust the stop bolts and adjustment bolts until the outside of the saw head is 1/16" (1.5mm) higher than the inside. Retighten the retaining plate bolts.

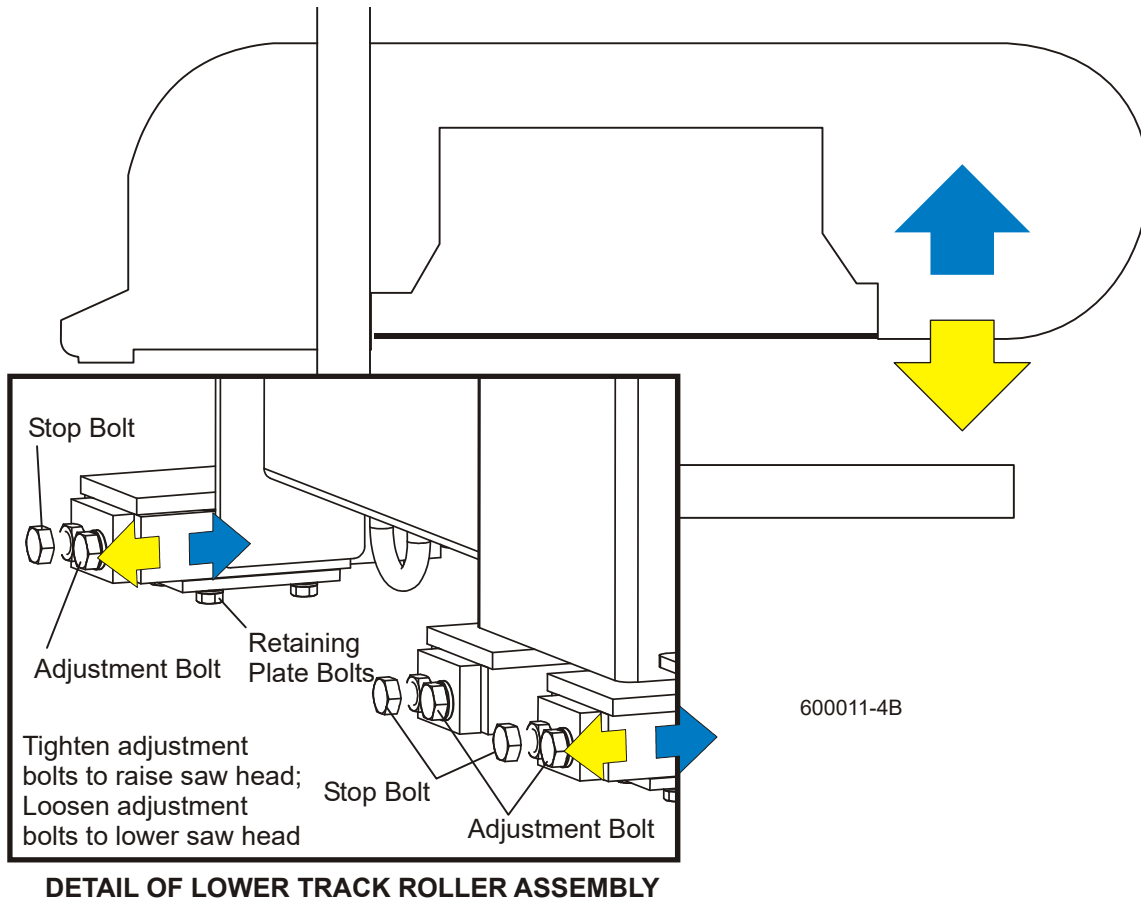

FIG. 7-2

Blade Guide Arm Alignment

The blade guide arm moves the outer blade guide in and out. If the arm becomes loose, the blade guide will not deflect the blade properly, causing inaccurate cuts. A loose blade guide arm can also cause blade vibration.

1. Adjust the blade guide arm in to 1/2" (13 mm) from fully closed.
2. Manually try to move the arm up and down. If you can move the arm by hand, you will need to tighten the arm rollers.

7 Sawmill Alignment

Blade Guide Arm Alignment

See **Figure 7-3**. Loosen the jam nuts and turn the adjustment bolts in to tighten the blade guide arm rollers. Retighten the jam nuts.

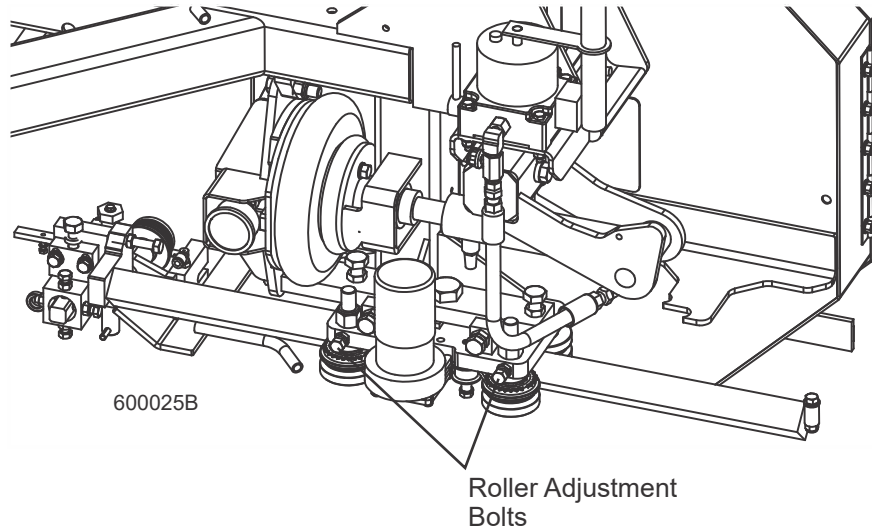

FIG. 7-3

After tightening the blade guide arm rollers, check that the arm is aligned properly.

3. With the arm adjusted 1/2" (12.7 mm) from fully closed, measure the distance between the blade guide roller flange and the back of the blade.

See **Figure 7-4**.

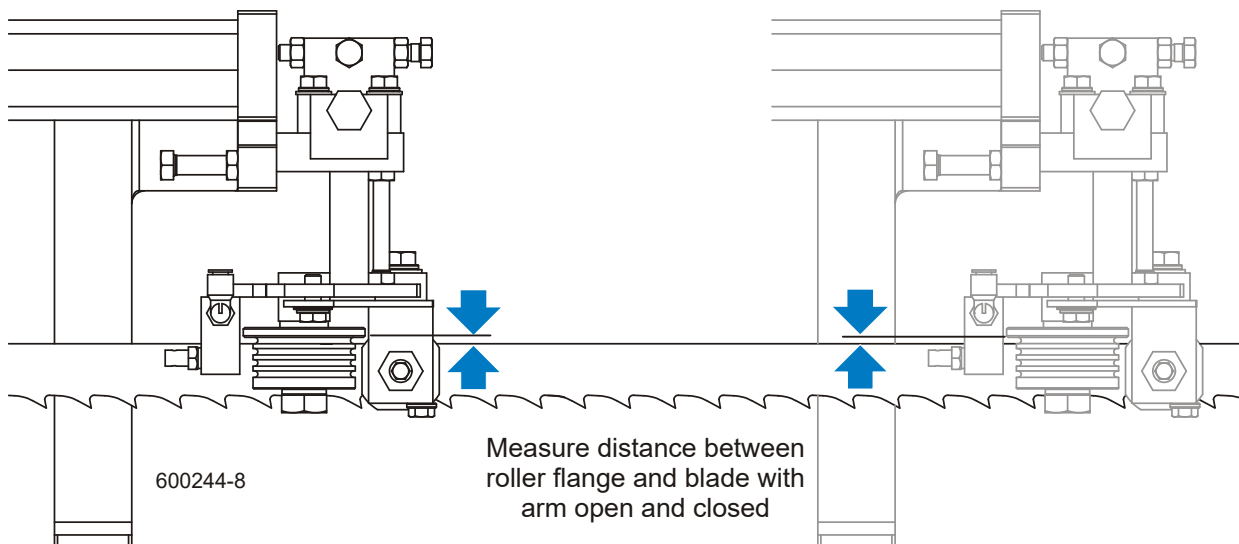

FIG. 7-4

4. Adjust the blade guide arm to 1/2" (12.7 mm) from fully open and remeasure the distance from the roller flange to the back of the blade. The two measurements should be the same. If not, adjust the outer rollers in or out to tilt the arm horizontally.

See Figure 7-5. Loosen the horizontal adjustment bolt jam nuts. To tilt the arm in toward the blade, loosen the rear bolt and tighten the front bolt. To tilt the arm out away from the blade, loosen the front bolt and tighten the rear bolt. Retighten the jam nuts and recheck the blade guide arm horizontal tilt.

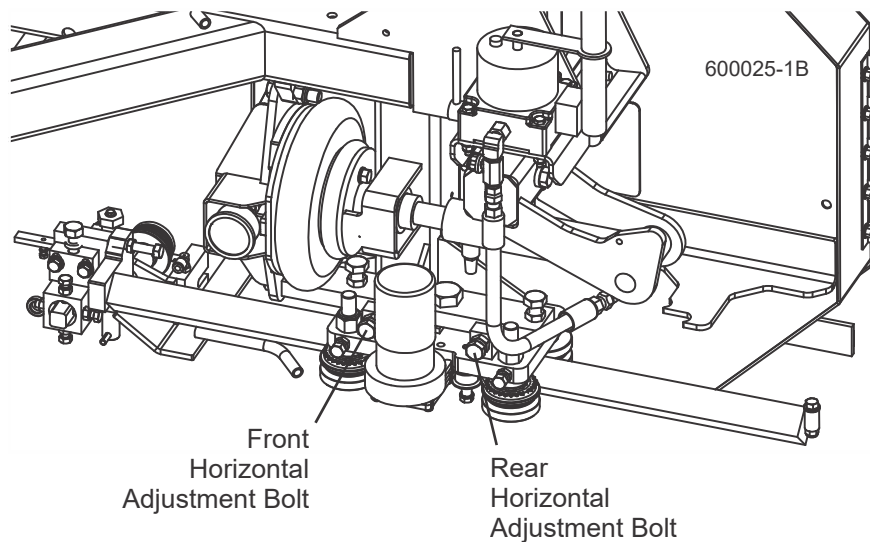

FIG. 7-5

5. Now check the vertical tilt of the blade guide arm. Move the saw carriage so the blade guide arm is positioned over a bed rail.
6. With the arm 1/2" (13 mm) from fully closed, raise or lower the saw head until the bottom of the blade guide block is 15" (375 mm) from the top of the bed rail.

7 Sawmill Alignment

Blade Guide Arm Alignment

See Figure 7-6.

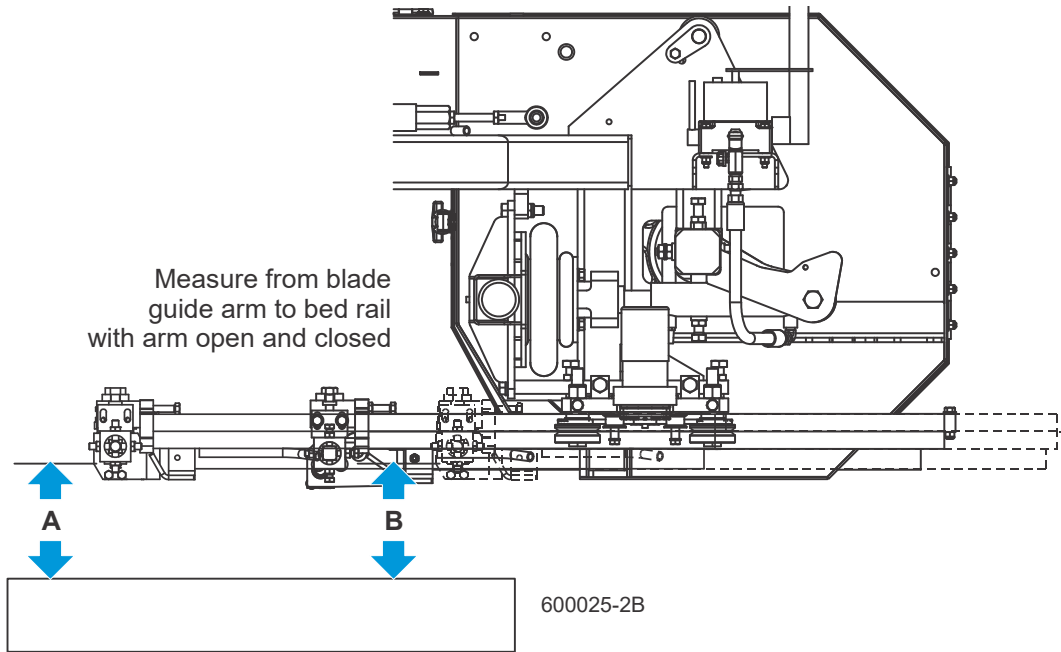

FIG. 7-6

7. Adjust the blade guide arm to 1/2" (13 mm) from fully open. Measure the distance from the bottom of the blade guide mounting block to the bed rail. This measurement should be 15" (376.5 mm) or slightly higher because the saw head is tilted up 1/16" (1.5 mm) on the outside ([See Saw Head Tilt](#)). If the blade guide is closer to the bed rail or more than 1/16" (1.5mm) higher with the arm open, adjust the blade guide arm vertically.

See Figure 7-7. Loosen the vertical adjustment bolt jam nuts. To tilt the blade guide arm down, loosen the rear bolt and tighten the front bolt. To tilt the blade guide arm up, loosen the front bolt and tighten the rear bolt. Retighten the jam nuts and recheck the blade guide arm vertical tilt.

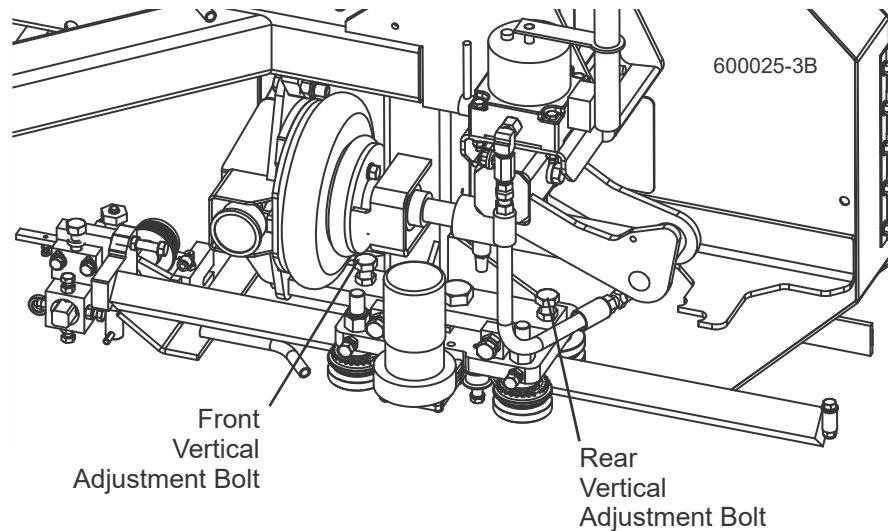

FIG. 7-7

Blade Guide Vertical Tilt Alignment

The blade guides should be adjusted properly in the vertical plane. If the blade guides are tilted vertically, the blade will try to travel in the tilted direction.

A Blade Guide Alignment Tool (BGAT) is provided to help you measure the vertical tilt of the blade.

1. Open the adjustable blade guide arm 1/2" (13 mm) from full open.
2. Clip the alignment tool on the blade. Position the tool close to the outer blade guide assembly. Be sure the tool does not rest on a tooth or burr, and is lying flat against the bottom of the blade.

See Figure 7-8.

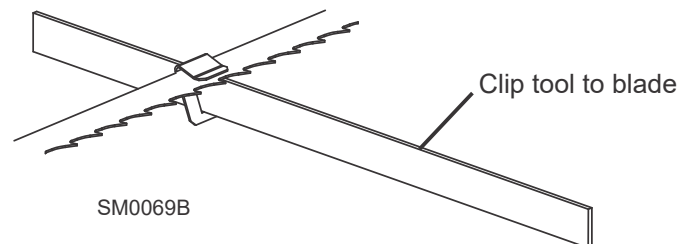

FIG. 7-8

7

Sawmill Alignment

Blade Guide Horizontal Tilt Adjustment

3. Move the carriage so that the front end of the tool is positioned above the bed rail. Measure the distance from the bed rail to the bottom edge of the tool.
4. Move the carriage so that the back end of the tool is positioned above the bed rail. Measure the distance from the bed rail to the bottom edge of the tool.
5. If the measurement from the tool to the bed rail is not equal within 1/32" (.75 mm), adjust the vertical tilt of the outer blade guide roller.
6. Loosen one set screw at the side of the blade guide assembly.

See Figure 7-9. Loosen the jam nuts on the top and bottom vertical tilt adjustment screws. To tilt the roller up, loosen the bottom screw and tighten top screw. To tilt the roller down, loosen the top screw and tighten the bottom screw. Tighten the jam nuts and recheck the tilt of the blade.

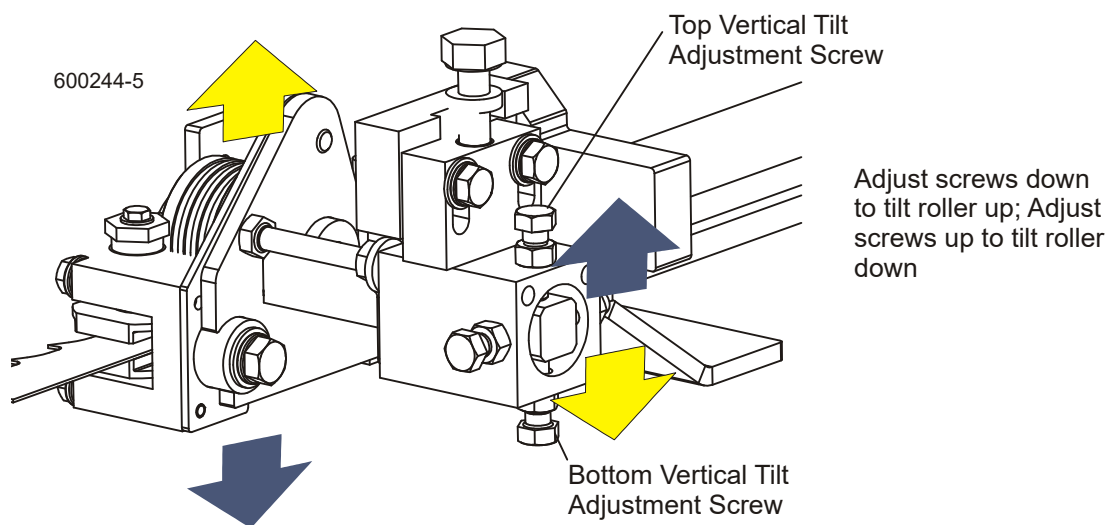

FIG. 7-9

7. Move the blade guide alignment tool close to the inner blade guide roller assembly and repeat the above steps. Adjust the vertical tilt of the inner blade guide if necessary.

Blade Guide Horizontal Tilt Adjustment

If the blade guides are tilted in the wrong direction horizontally, the back of the blade may contact the flange as the roller is spinning down, causing it to push the blade away from the guide roller.

8. Remove the blade guide alignment tool from the blade and adjust the blade guide arm halfway in.

9. Remove the clip from the blade guide alignment tool. Place the tool against the face of the outer blade guide roller.

See Figure 7-10.

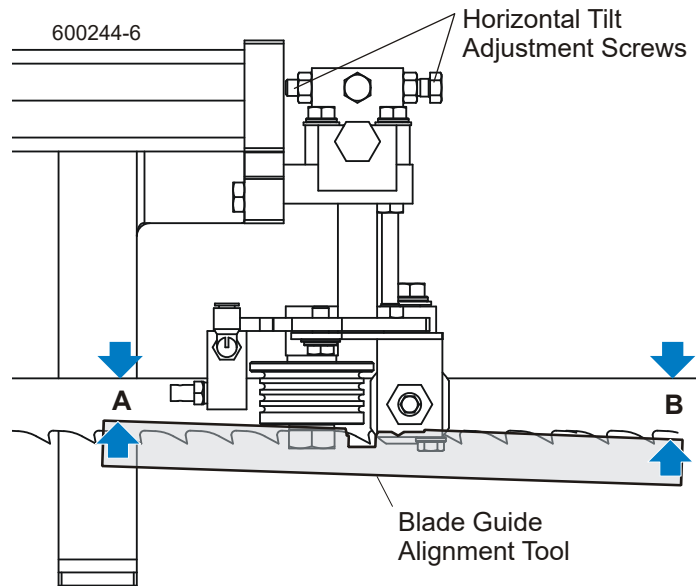

FIG. 7-10

10. Measure between the back edge of the blade and the tool at the end closest to the inner blade guide ("B").
11. Measure between the back edge of the blade and the other end of the tool ("A").

The roller should be tilted slightly to the left ('A' $1/8$ " [3 mm] less than 'B' $\pm 1/8$ " [3 mm]).

See Figure 7-11. Loosen the jam nuts on the horizontal tilt adjustment screws. To tilt the roller left, loosen the right screw and tighten left screw. To tilt the roller right, loosen the left screw and tighten the right screw. Tighten the jam nuts and recheck the tilt of the blade.

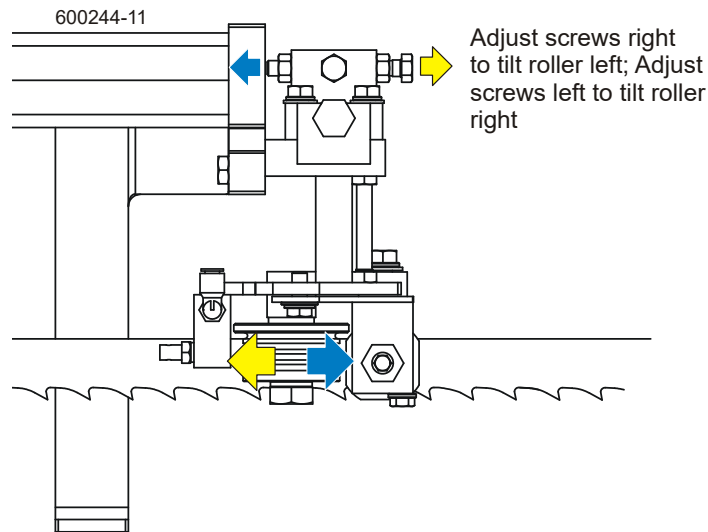

FIG. 7-11

12. Repeat the above steps for the inner blade guide roller assembly.

NOTE: Once the blade guides have been adjusted, any cutting variances are most likely caused by the blade. [See Blade Handbook, Form #600.](#)

Blade Guide Flange Spacing

Each blade guide must be adjusted so the roller flange is the correct distance from the back edge of the blade. If the flange is too close to or too far from the blade, the sawmill will not cut accurately.

HINT: When adjusting blade guide spacing, loosen the top set screw and one side set screw only. This will ensure horizontal and vertical tilt adjustments are maintained when the adjustment screws are retightened.

1. Measure the distance between the flange on the outer blade guide roller to the back edge of the blade. This distance should measure 1/8" (3.0 mm). Adjust the roller back or forward if necessary.

See Figure 7-12. Loosen the top and one side screw shown. Back the stop bolt out of the way if necessary. Tap the blade guide forward or backward until properly positioned.

Retighten the screws and jam nuts. Adjust the stop bolt against the blade guide assembly.

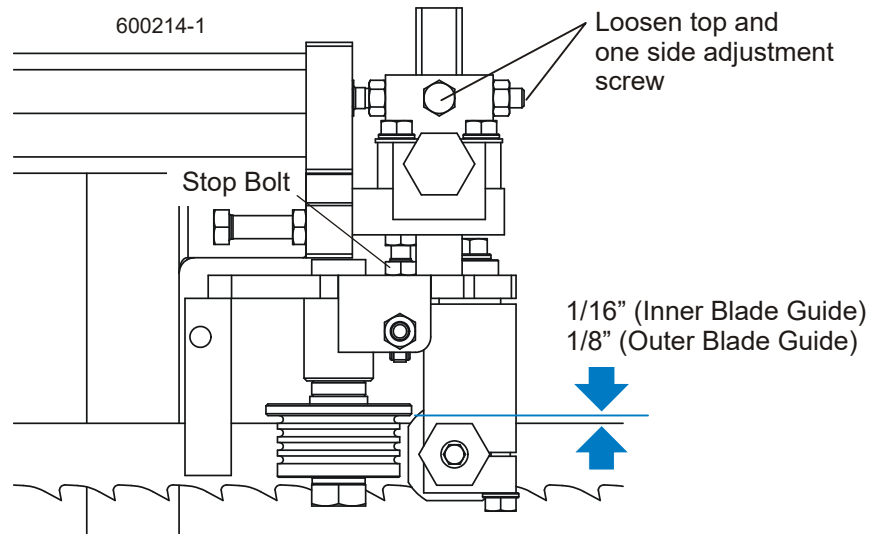

FIG. 7-12

2. Measure the distance between the flange on the inner blade guide roller to the back edge of the blade. This distance should measure 1/16" (1.5 mm). Adjust the roller back or forward if necessary.

Manual Side Support Alignment

Logs and boards are clamped against the side supports when sawing. The sides supports must be square to the bed to ensure square lumber.

1. Swing a side support down and measure between the face of the support and the main bed tube. The distance at the top of the side support ('B') should be equal to or no more

7 Sawmill Alignment

Manual Side Support Alignment

than 1/32" (0.8 mm) greater than the distance at the base of the side support ('A'). Adjust the horizontal tilt of the side support if necessary.

See Figure 7-13. Loosen the two adjustment plate mounting bolts. Use a mallet to move the plate until the side support is parallel to the bed tube in the horizontal position. Retighten the mounting bolts.

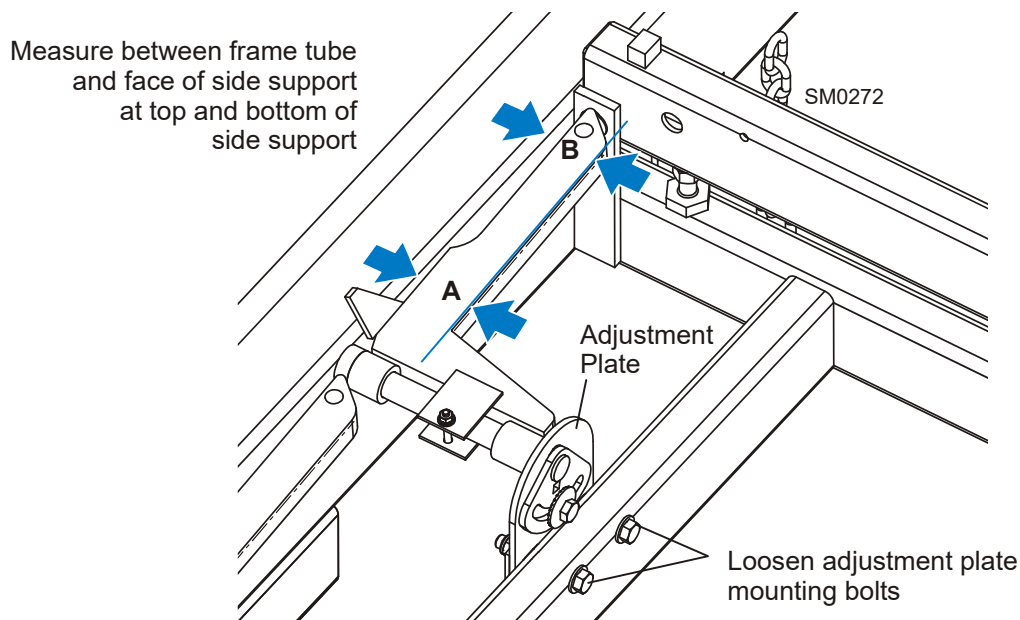

FIG. 7-13

2. Repeat the horizontal check for the remaining side supports. Adjust as necessary.
3. Place square alignment tubes (Part No. S12831 - 2 required) across the bed rails. Swing a side support up so that it is vertical.
4. Pull back at the top of the support to eliminate slack as if a log were being clamped against it.
5. Place a square against the face of the side support. The side support should be square or slightly tilted forward 1/32" (0.8 mm). Adjust the vertical tilt of the side support if necessary.

See Figure 7-14. Loosen the side support mounting bolt. Use a 3/8" ratchet to rotate the pin until the side support is square to the bed.

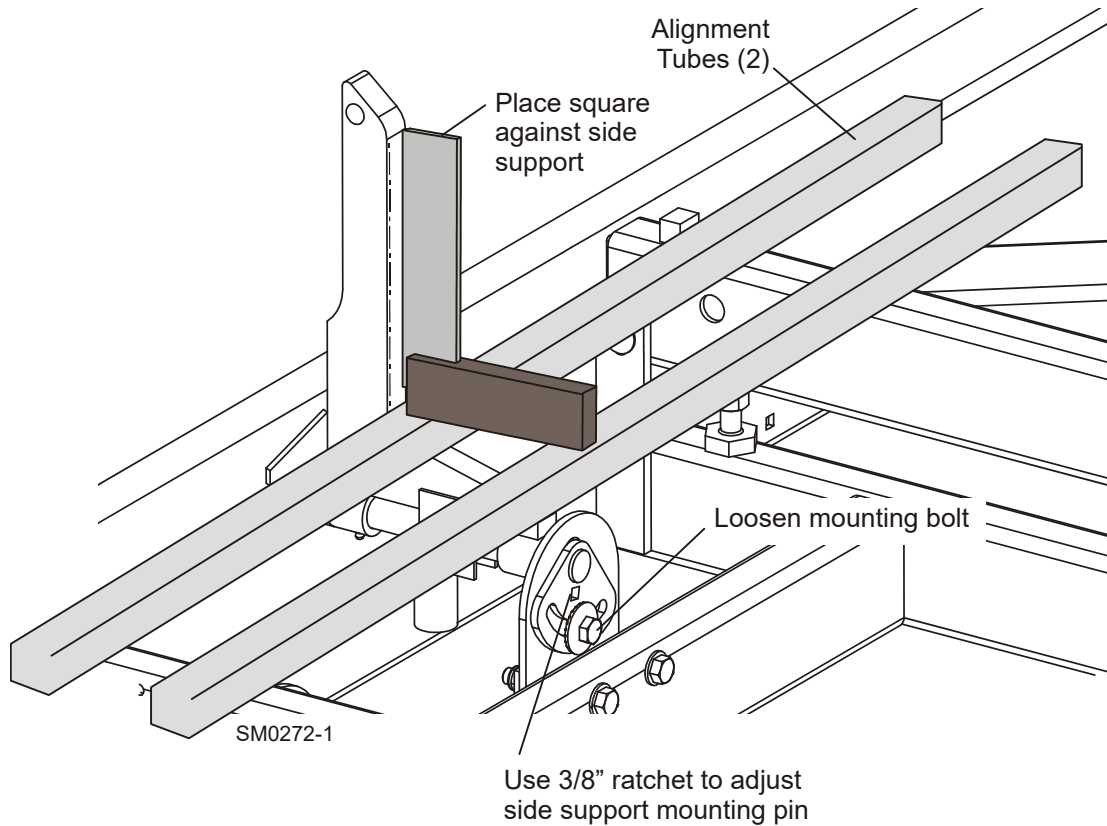

FIG. 7-14

6. Repeat the vertical check for the remaining side supports and adjust as necessary.

Hydraulic Side Support Alignment

Place the square against the face of the side support. The side support should be square or slightly tilted forward 1/32" (0.8 mm). Adjust the vertical tilt of the side support if necessary.

See Figure 7-15. Loosen the top jam nut. Adjust the two lower jam nuts up to tilt the side support back. Adjust the two lower jam nuts down to tilt the side support forward. Retighten the top jam nut and repeat for the other hydraulic side support.

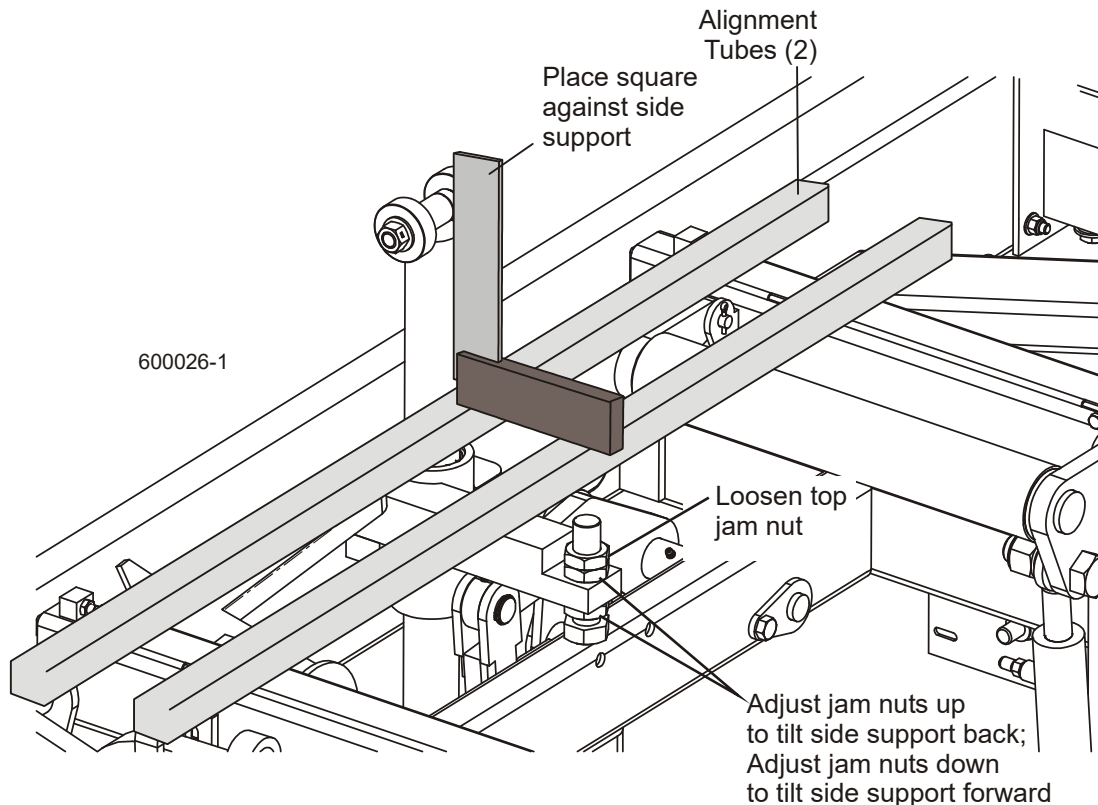

FIG. 7-15

Blade Height Scale Adjustment

After the entire sawmill has been aligned and all adjustments made, check that the blade height scale indicates the true distance from the blade to the bed rails.

1. Move the saw carriage so the blade is positioned directly above one of the bed rails. Measure from the bottom edge on a down-set tooth of the blade to the top of the bed rail, near the inner blade guide assembly.
2. View the blade height scale with eyes level with the indicator. The scale should indicate the actual distance from the blade to the bed rail. Adjust the indicator if necessary.

See Figure 7-16. Loosen the scale bracket mounting bolts. Adjust the bracket up or down until the indicator is aligned with the correct mark on the scale (+0 -1/32 [0.8 mm]). Retighten the bracket mounting bolts.

For example, if the measurement from the down-set tooth of the blade to the bed rail was 14 3/4" (375 mm), make sure the indicator reads 14 3/4" (375 mm) on the scale.

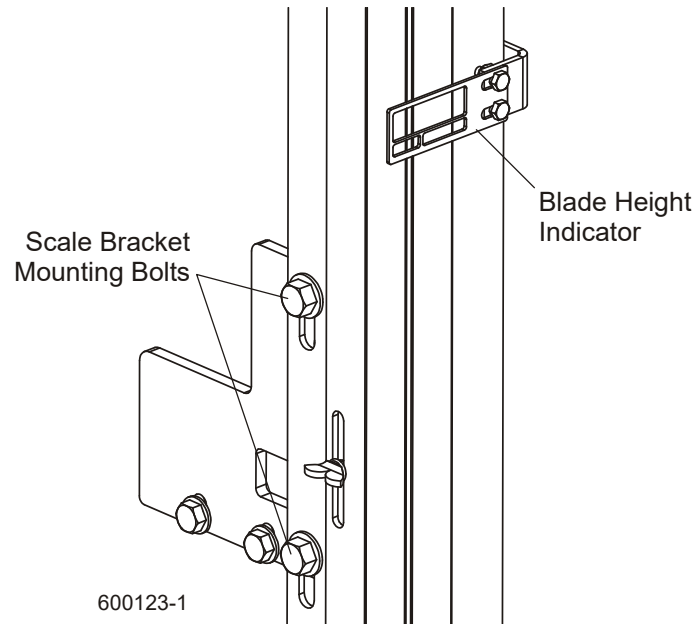

FIG. 7-16

7.2 Complete Alignment Procedure

Frame Setup

Before performing the following alignment procedures, setup the mill on firm, level ground.

If your sawmill is stationary, with no trailer axle, shim the feet so the weight of the sawmill is evenly supported.

If your sawmill has a trailer axle and adjustable outriggers, adjust the outriggers as follows:

Adjust the front and third outriggers on the main frame tube down just enough to lift weight from the trailer tire.

All Portable Sawmills: Adjust the two outer outriggers down just so they touch the ground but do not bear weight.

[See SECTION 3](#) for additional setup information.

Blade Installation

1. Remove the blade and replace the blade wheel belts. New blade wheel belts are required to perform the complete alignment procedure.
2. Blow sawdust off of the blade guide assemblies. Remove sawdust from the blade housings.
3. Remove the blade guide assemblies.

NOTE: To remove the blade guide assemblies and maintain the tilt adjustments, only loosen one side screw and the top screw. Leaving the other side screw and bottom screw in position will insure you will return the rollers to their original tilt adjustment.

4. Adjust the outer blade guide arm in or out until the outer blade guide is approximately 24" from the inner blade guide.
5. Install a new blade and apply the appropriate tension ([See Section 3.4](#)).
6. Close the blade housing covers and make sure all persons are clear of the saw head.
7. Start the engine (or motor).

8. Engage the blade, rotating the blade until the blade positions itself on the wheels.



WARNING! Do not spin the blade wheels by hand. Spinning the blade wheels by hand may result in serious injury.

9. Disengage the blade. Turn the engine off and remove the key.

Blade Wheel Alignment

The blade wheels should be adjusted so they are level in the vertical and horizontal planes. If the blade wheels are tilted up or down, the blade will want to travel in the tilted direction. If the blade wheels are tilted horizontally, the blade will not track properly on the wheels.

1. Use the blade guide alignment tool to check the vertical alignment of each blade wheel. Attach the tool to the blade near the inner blade guide mount. Be sure the tool does not rest on a tooth or burr, and is lying flat against the bottom of the blade.

See Figure 7-17.

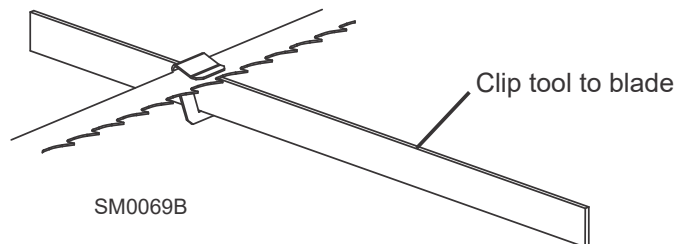

FIG. 7-17

2. Move the saw carriage so the front end of the tool is positioned over the first bed rail. Measure from the bottom of the tool to the top surface of the bed rail.
3. Move the saw carriage so the rear of the tool is positioned over the bed rail. Again, measure from the bottom of the tool to the bed rail.
4. If the two measurements differ by more than 1/16" (1.5 mm), adjust the vertical tilt of the drive-side blade wheel.

See Figure 7-18. Use the vertical adjustment screws to adjust the drive-side blade wheel. To tilt the wheel down, loosen the top adjustment screw one quarter turn. Loosen the jam nut on the bottom adjustment screw and tighten the screw. Tighten the top and bottom jam nuts.

To tilt the wheel up, loosen the bottom adjustment screw one quarter turn. Loosen the jam

7 Sawmill Alignment

Blade Wheel Alignment

nut on the top adjustment screw and tighten the screw. Tighten the top and bottom jam nuts.

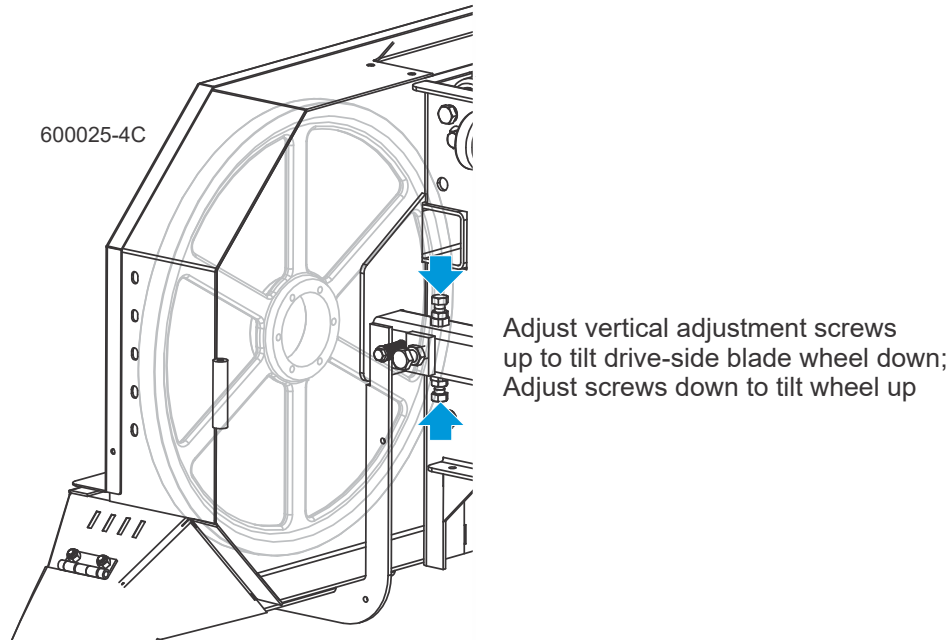

FIG. 7-18

5. Recheck the vertical tilt of the drive-side blade wheel with the blade guide alignment tool. Readjust the blade wheel as necessary until the front and rear of the tool are the same distance from the bed rail (within 1/16" [1.5 mm]).
6. Remove the tool from the blade and reattach it near the outer blade guide assembly.
7. Measure from the tool to the bed rail at both ends of the tool. If the measurements at the front and rear ends of the tool differ by more than 1/16" (1.5 mm), adjust the vertical tilt of the idle-side blade wheel.

See Figure 7-19. Use the vertical adjustment screws to adjust the idle-side blade wheel. To tilt the wheel up, loosen the bottom adjustment screw one quarter turn. Loosen the jam nut on the top adjustment screw and tighten the screw. Tighten the top and bottom jam nuts.

To tilt the wheel down, loosen the top adjustment screw one quarter turn. Loosen the jam

nut on the bottom adjustment screw and tighten the screw. Tighten the top and bottom jam nuts.

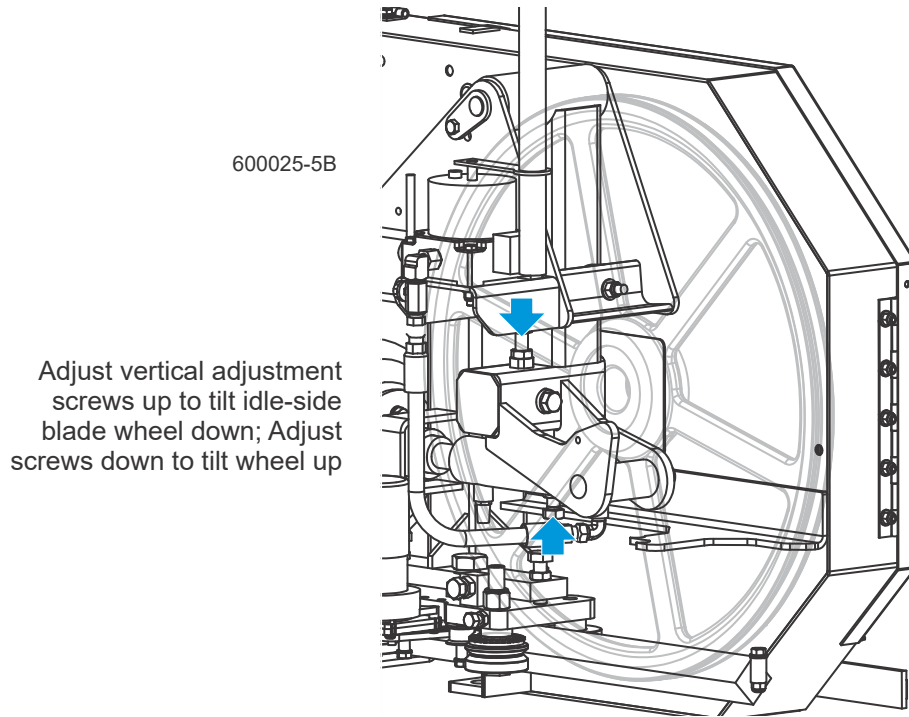

FIG. 7-19

See Figure 7-20.

8. Recheck the vertical tilt of the idle-side blade wheel with the blade guide alignment tool. Readjust the blade wheel as necessary until the front and rear of the tool are the same distance from the bed rail (within 1/16" [1.5 mm]).
9. Check the position of the blade on the idle-side blade wheel.

See Figure 7-21. The horizontal tilt of the blade wheel should be adjusted so that the gullet of an 1-1/4" blade is 1/8" (3 mm) out from the front edge of the wheel ($\pm 1/16$ [1.5

7 Sawmill Alignment

Blade Wheel Alignment

mm]). The gullet of an 1-1/2" blade should be 3/16" (4.5 mm) out from the front edge of the wheel ($\pm 1/16$ [1.5 mm]). Do not let the teeth ride on the wheels.

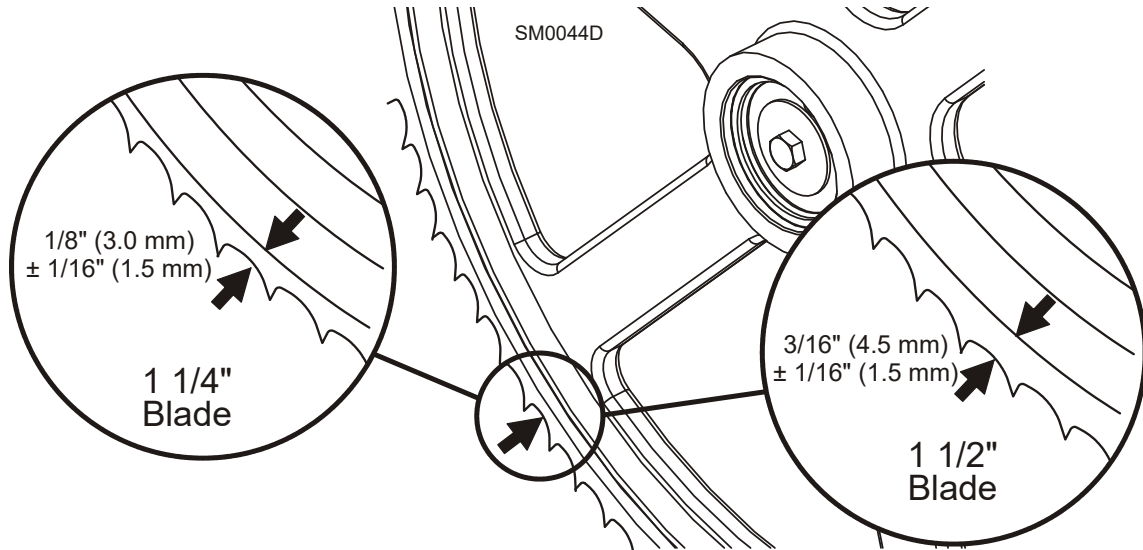

FIG. 7-21

See Figure 7-22. Use the cant control adjustment to adjust the idle-side blade wheel. If the blade is too far forward on the wheel, turn the cant control counterclockwise. If it is too far back on the wheel, turn the cant control clockwise.

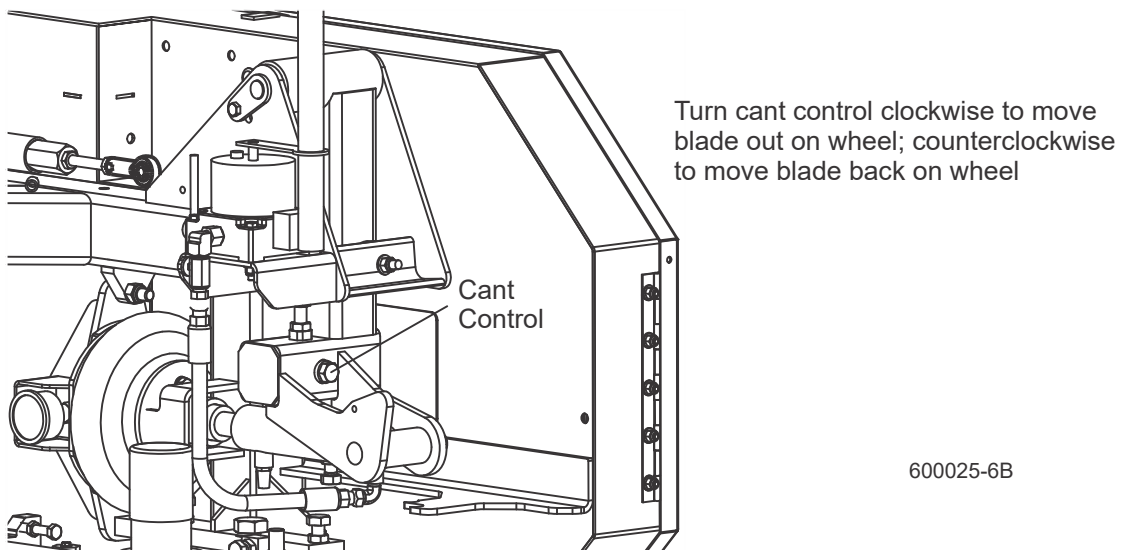

FIG. 7-22

10. Check the position of the blade on the drive-side blade wheel. The blade should be positioned on the wheel as described for the idle-side blade wheel. Adjust the drive-side blade wheel if necessary.

See Figure 7-23.

Use the horizontal adjustment screw to adjust the drive-side blade wheel. Loosen the top vertical screw to allow movement of the drive shaft. To move the blade back on the wheel, loosen the jam nut and turn the horizontal adjustment screw clockwise one quarter turn. To move the blade out on the wheel, loosen the jam nut and turn the horizontal adjustment screw counterclockwise one quarter turn.

Repeat adjustments in quarter-turn increments until the blade tracks properly on the drive-side blade wheel. Tighten the horizontal adjustment screw jam nut and the top vertical screw.

See Figure 7-24.

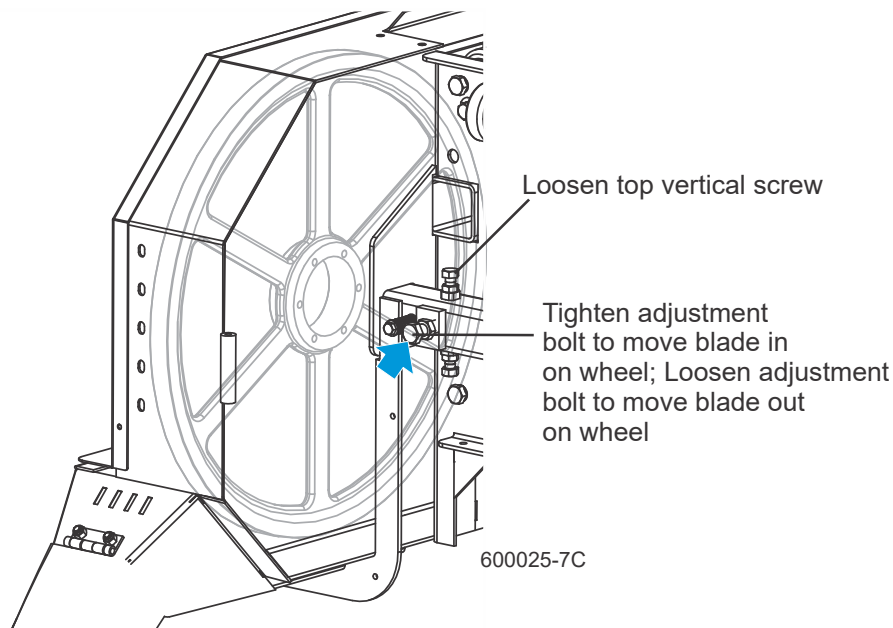

FIG. 7-24

Track Roller Adjustment

Making these adjustments correctly will insure the saw carriage travels smoothly along the track and blade will remain parallel with the bed frame.

1. Using the feed controls, move the saw carriage so that the blade is positioned over the front pivot end rail.
2. Check the lower track rollers. The front roller and the two rear rollers should touch the rail so that you cannot spin them by hand. If the rollers are not adjusted evenly and you can spin one by hand, use the adjustment bolts to adjust the roller.

7 Sawmill Alignment

Track Roller Adjustment

See Figure 7-25.

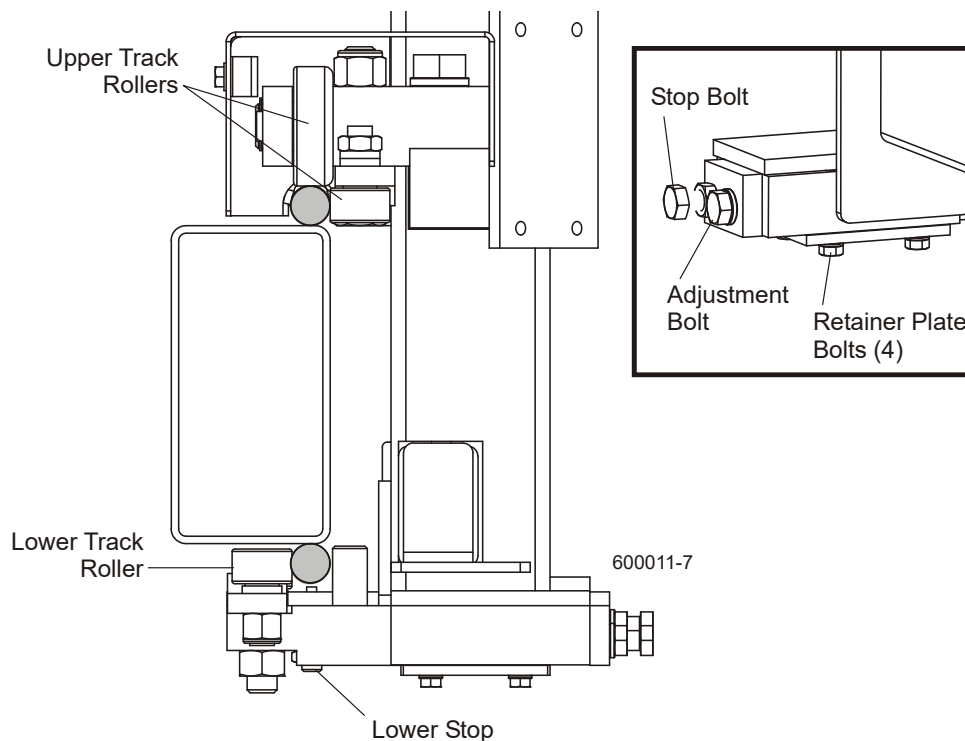

FIG. 7-25

Loosen the four retaining plate bolts. Back out the stop bolt and tighten the adjustment bolt to move the track roller(s) toward the rail. When the roller touches the rail so you cannot spin it by hand, retighten the stop bolt and the retaining plate bolts.

Observe the middle upper and lower track rollers as you move the saw carriage down the track. The middle rollers should touch the rail throughout most of the saw carriage travel. Be careful not to tighten the rollers so they cause the carriage to bind as it travels down the track. If the rollers do not spin at least half the distance of the track, tighten them as described above.

3. Open the adjustable blade guide arm to within 1/2" (15 mm) of full open.
4. Move the carriage back to the front pivot end rail. Raise the cutting head until the bottom of the blade is 17" (400 mm) above the outside of the pivot rail support by actual measurement with a tape or ruler.

See Figure 7-26.

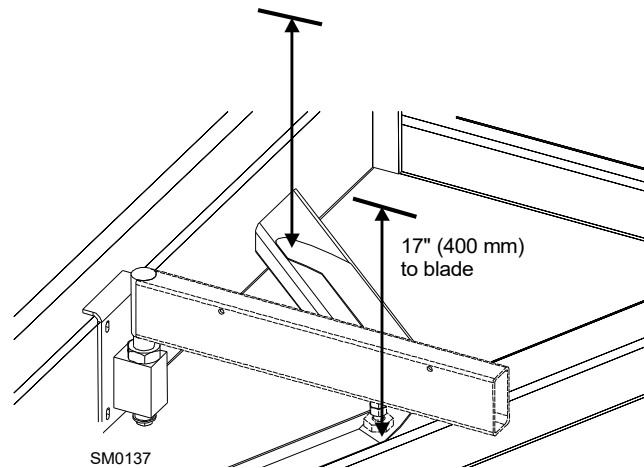

FIG. 7-26

5. Move the carriage forward to check the distance to the blade at the inside of the pivot rail support. All measurements should be equal within $1/32"$ (0.8 mm).

See Figure 7-27. To adjust the saw head tilt, use the bolts located at the bottom of the saw head mast. Loosen the three sets of four retaining plate bolts. To raise the outside of the saw head, back the stop bolts out, then tighten the adjustment bolts. To lower the out-

7

Sawmill Alignment*Bed Rail Adjustment*

side of the saw head, loosen the adjustment bolts and tighten the stop bolts. Recheck the saw head tilt and readjust the bolts as necessary. Retighten the retaining plate bolts.

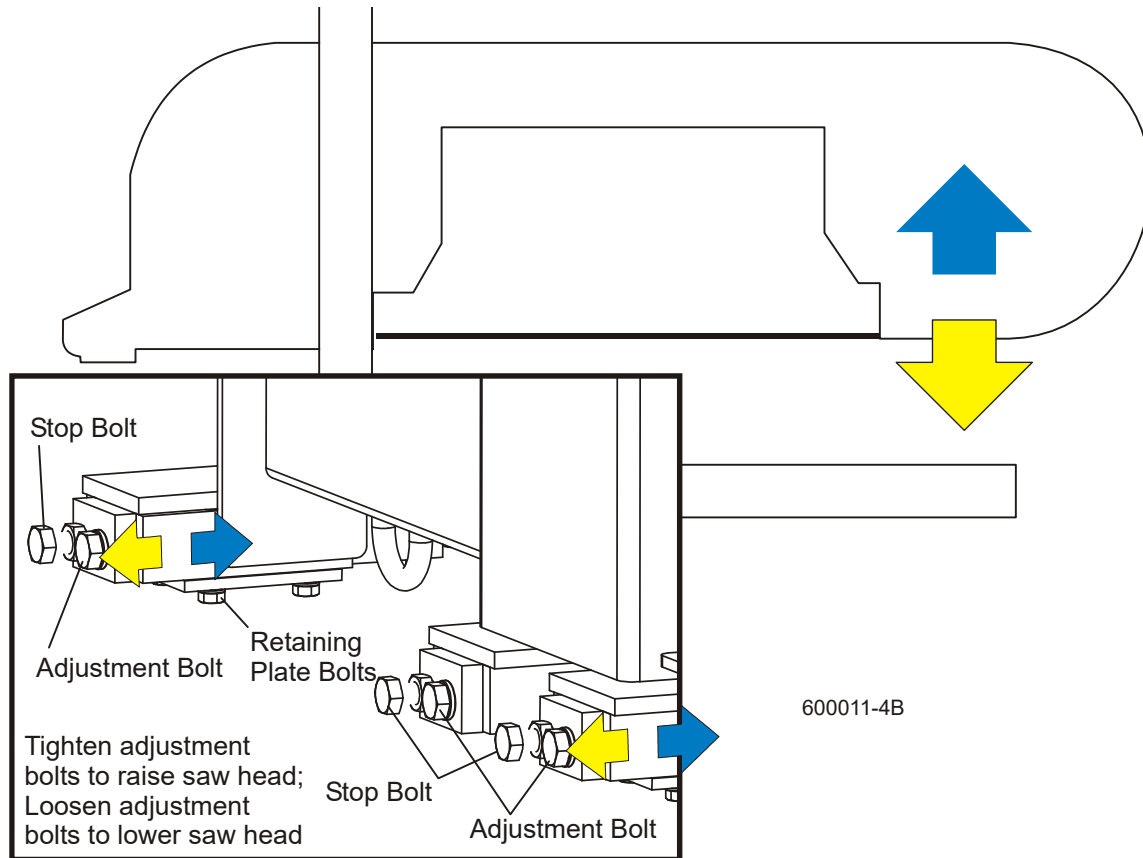

DETAIL OF LOWER TRACK ROLLER ASSEMBLY

FIG. 7-27

6. After the lower track rollers are adjusted properly, adjust the upper and lower stop screws. Tighten each screw until it just touches the rail. Then, back the screw off 1/2 turn. The gap will be approximately 1/32" (0.8mm).



CAUTION! It is important that the lower stop bolts are properly adjusted to secure the carriage on the track rail. Failure to properly adjust the stop bolts can cause saw head damage, especially during mill transportation.

Bed Rail Adjustment

1. Move the clamp so it is 10" (254mm) from the clamp stop. Adjust the clamp down to its lowest position. Move the saw head forward until it is positioned over the clamp. Raise the saw head until the blade measures 15 5/16" (385 mm) from the clamp at its lowest position.
2. Adjust the front pivot rail 90° to the main bed tube.

3. Move the saw head to center the blade over the front pivot bed rail.
4. Measure the distance from the top of the pivot rail to the bottom of the blade. Make this measurement at each end of the pivot rail.
5. The two measurements should be 15" (375 mm).

See Figure 7-28. Loosen the locking set screws and turn the inner height adjustment nut to adjust the height of the inner end of the pivot rail. Loosen the jam nut and turn the outer adjustment bolt to adjust the height of the outer end of the pivot rail.

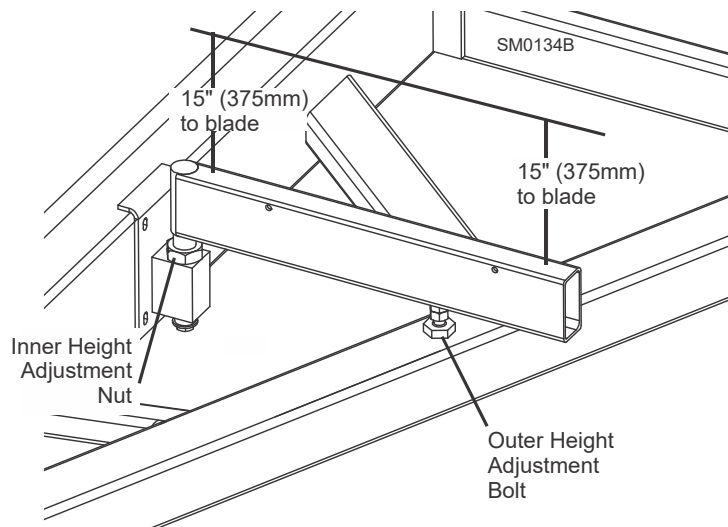

FIG. 7-28

6. Move the saw head so the blade is positioned over the center of the front main bed rail.
7. Measure the distance between the bottom of the blade and the bed rail at each end of the bed rail. The bed rail should measure 15" (375 mm) from the blade at each end of the rail.

7 Sawmill Alignment

Blade Guide Installation

See Figure 7-29. Loosen the bed rail clamping bolts and turn the adjustment bolts to move the bed rails to the blade if necessary. Retighten the clamping bolts and adjustment bolt jam nuts.

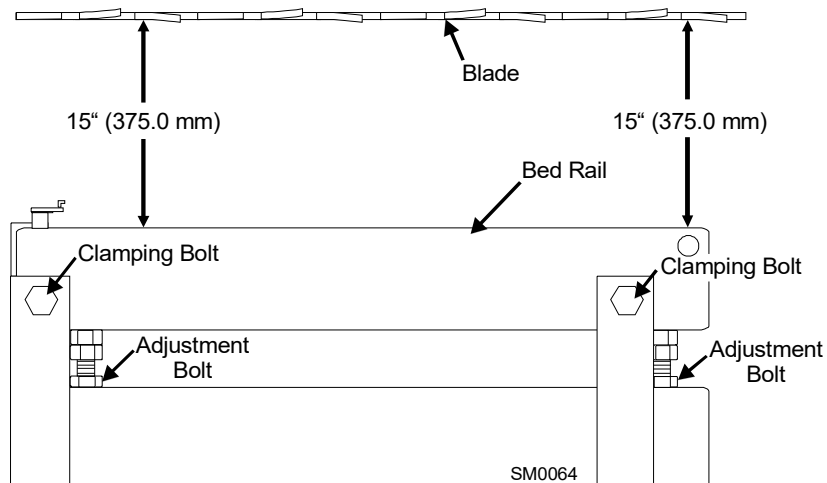

FIG. 7-29

- Without adjusting the saw head height, check the three remaining main bed rails and the rear pivot rail. Adjust them so that all measure the same distance from the blade at both ends of the bed rail.

Blade Guide Installation

Each Wood-Mizer sawmill has two blade guide assemblies that help the blade maintain a straight cut. The two blade guide assemblies are positioned on the saw head to guide the blade on each side of the material being cut.

One blade guide assembly is mounted in a stationary position on the drive side of the saw head. This assembly is referred to as the "inner" blade guide assembly.

The other blade guide assembly is mounted on the idle side of the saw head. It is referred to as the "outer" assembly and is adjustable for various widths of materials to be processed.

NOTE: Before installing the blade guide assemblies, remove the blade guide adjusting screws and apply a lubricating oil such as 10W30 or Dexron III to each screw. This will prevent the screws and threaded holes from corroding and make screw adjustments easier.

See Figure 7-30. Inspect the guide blocks and repair or replace as necessary. Remove the blade from the sawmill.

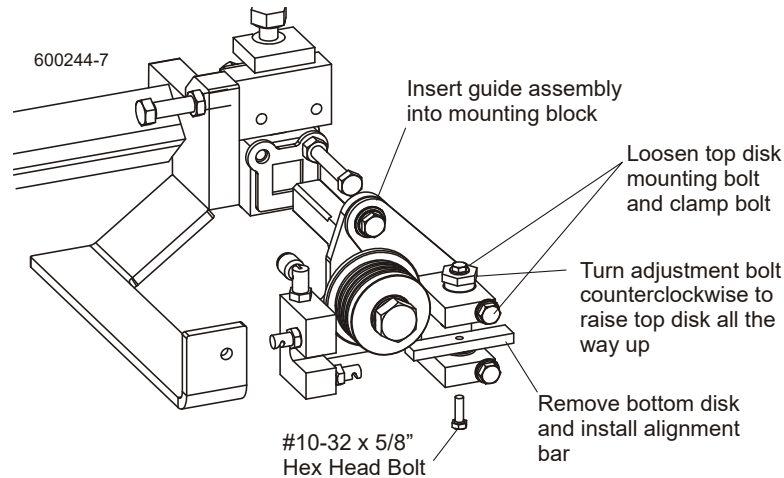

FIG. 7-30

9. Loosen the top block clamp bolt and mounting bolt. Turn the adjustment bolt counterclockwise to raise the top block all the way up. Remove the bottom guide block from each blade guide assembly and install the provided alignment bar.
10. Install each blade guide assembly to the mounting blocks and push all the way back. Install, tension and track a new blade. Adjust the outer blade guide assembly so the roller flange is 1/8" from the back of the blade. Adjust the inner blade guide assembly so the roller flange is 1/16" from the blade.

Tighten the two previously-loosened tilt adjustment screws to secure the blade guide assembly.

Turn the top adjustment bolt clockwise to raise the blade guide assembly so the roller does not contact the blade.

NOTE: Before adjusting the top bolt, unload pressure on the bolt by turning 1/2 turn in the opposite direction it was last adjusted.

With the roller flange positioned properly from the back of the blade, adjust the stop bolt so it touches the blade guide bracket.

7 Sawmill Alignment

Blade Guide Arm Alignment

See Figure 7-31.

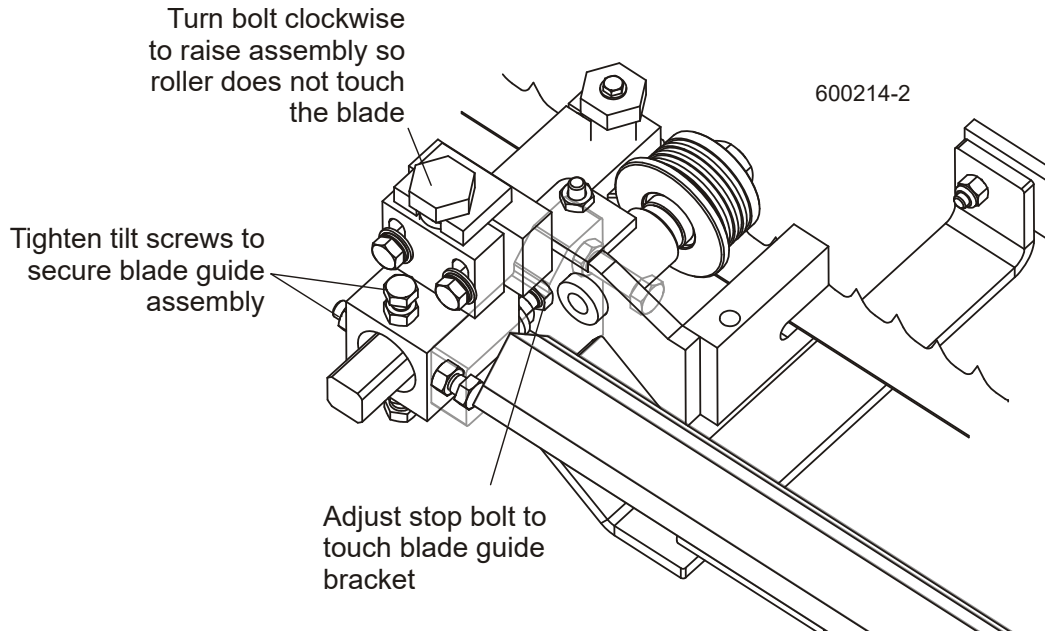

FIG. 7-31

Blade Guide Arm Alignment

The blade guide arm moves the outer blade guide in and out. If the arm becomes loose, the blade guide will not deflect the blade properly, causing inaccurate cuts. A loose blade guide arm can also cause blade vibration.

1. Adjust the blade guide arm in to 1/2" (13 mm) from fully closed.
2. Manually try to move the arm up and down. If you can move the arm by hand, you will need to tighten the arm rollers.

See Figure 7-32. Loosen the jam nuts and turn the adjustment bolts in to tighten the blade guide arm rollers. Retighten the jam nuts.

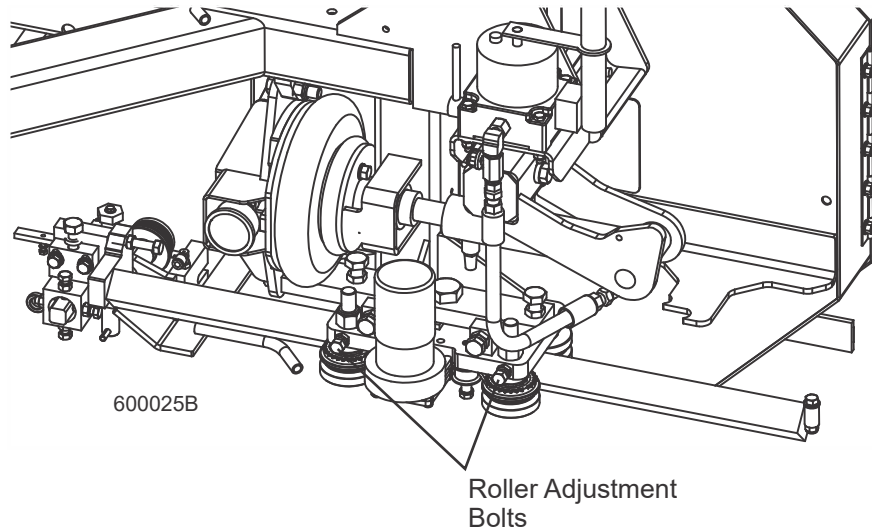

FIG. 7-32

After tightening the blade guide arm rollers, check that the arm is aligned properly.

3. With the arm adjusted 1/2" (13 mm) from fully closed, measure the distance between the blade guide roller flange and the back of the blade.

See Figure 7-33.

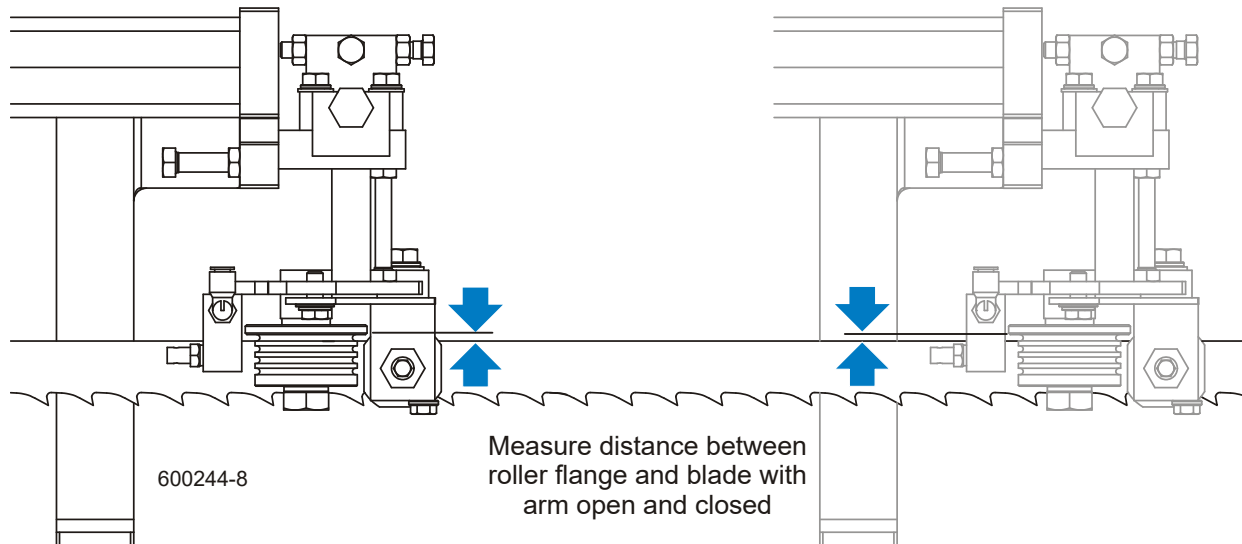

FIG. 7-33

4. Adjust the blade guide arm to 1/2" (13 mm) from fully open and remeasure the distance from the roller flange to the back of the blade. The two measurements should be the same. If not, adjust the inner rollers in or out to tilt the arm horizontally.

See Figure 7-34. Loosen the horizontal adjustment bolt jam nuts. To tilt the arm in toward the blade, loosen the rear bolt and tighten the front bolt. To tilt the arm out away from the

blade, loosen the front bolt and tighten the rear bolt. Retighten the jam nuts and recheck the blade guide arm horizontal tilt.

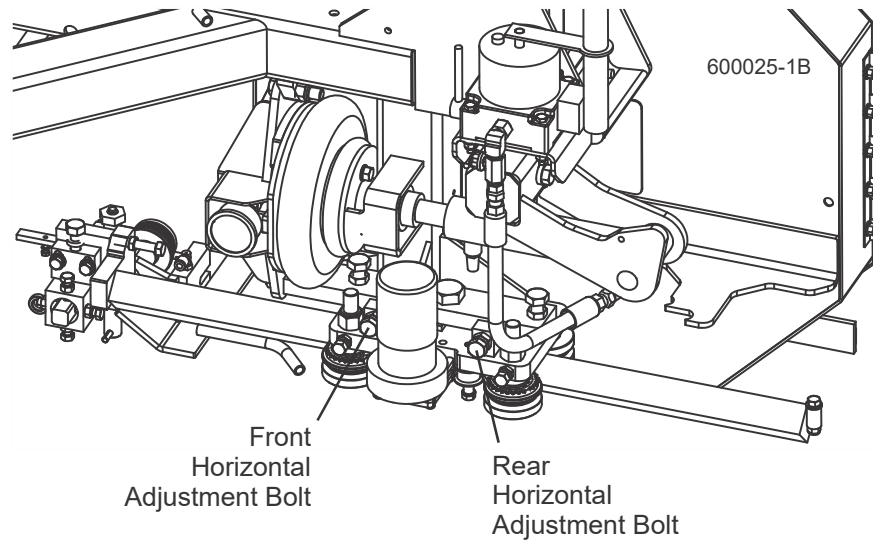

FIG. 7-34

5. Now check the vertical tilt of the blade guide arm. Move the saw carriage so the blade guide arm is positioned over a bed rail.
6. With the arm 1/2" (15 mm) from fully closed, raise or lower the saw head until the bottom of the blade guide block is 15" (375 mm) from the top of the bed rail.

See Figure 7-35. Adjust the blade guide arm to 1/2" (15 mm) from fully open. Measure the distance from the bottom of the blade guide mounting block to the bed rail. This mea-

7 Sawmill Alignment

Blade Guide Arm Alignment

surement should be 15" (376.5 mm). If the measurements are not the same, adjust the blade guide arm vertically.

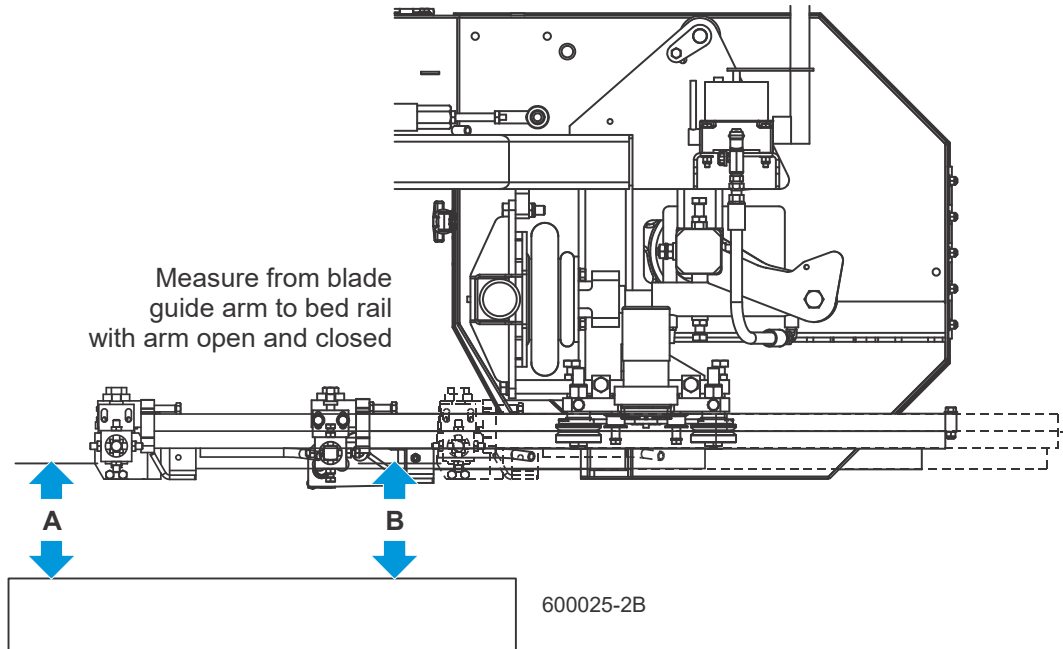

FIG. 7-35

See Figure 7-36. Loosen the vertical adjustment bolt jam nuts. To tilt the blade guide arm down, loosen the rear bolt and tighten the front bolt. To tilt the blade guide arm up, loosen the front bolt and tighten the rear bolt. Retighten the jam nuts and recheck the blade guide arm vertical tilt.

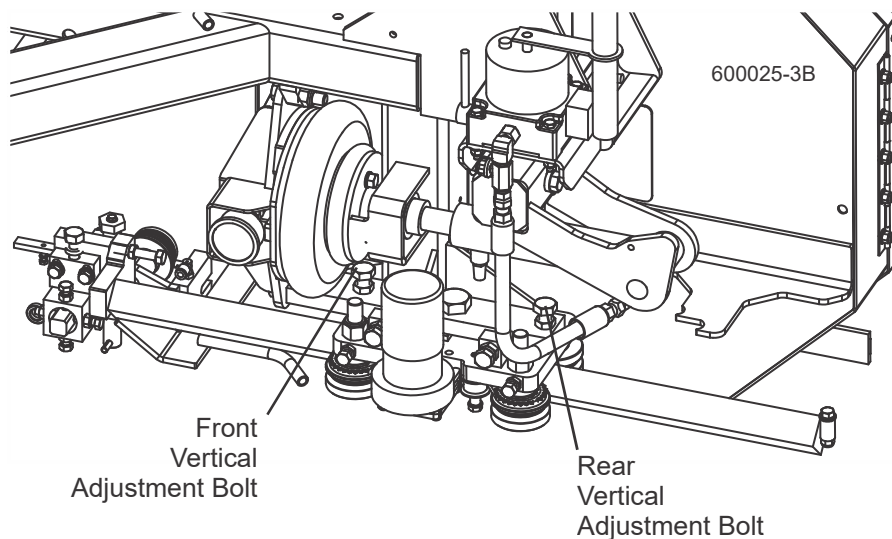

FIG. 7-36

Blade Guide Deflection

7. Raise the saw head until the blade is 15" (375 mm) above a bed rail. Measure the actual distance with a tape from the top of the rail to the bottom of the blade.

See **Figure 7-37**. Turn the top adjustment bolt counterclockwise to lower the assembly until the blade guide roller deflects the blade down until the bottom of the blade measures 14 3/4" (370 mm) from the bed rail.

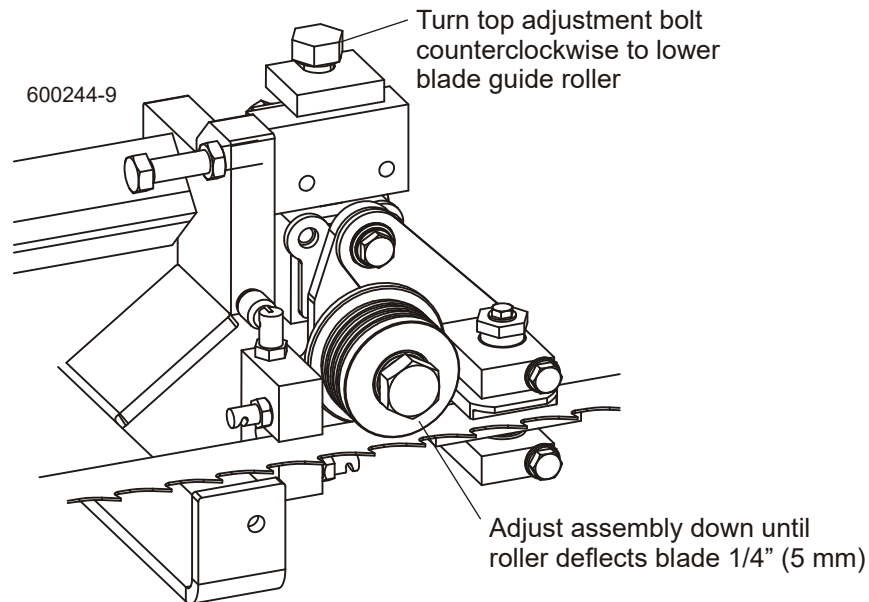

FIG. 7-37

NOTE: Before adjusting the top bolt, unload pressure on the bolt by turning 1/2 turn in the opposite direction it was last adjusted.

8. Repeat for the other blade guide.

Blade Guide Vertical Tilt Alignment

The blade guides should be adjusted properly in the vertical plane. If the blade guides are tilted vertically, the blade will try to travel in the tilted direction.

A Blade Guide Alignment Tool (BGAT) is provided to help you measure the vertical tilt of the blade.

1. Open the adjustable blade guide arm 1/2" (13 mm) from full open.
2. Clamp the alignment tool on the blade. Position the tool close to the outer blade guide roller. Be sure the tool does not rest on a tooth or burr, and is lying flat on the blade.

7

Sawmill Alignment*Blade Guide Vertical Tilt Alignment*

See Figure 7-38.

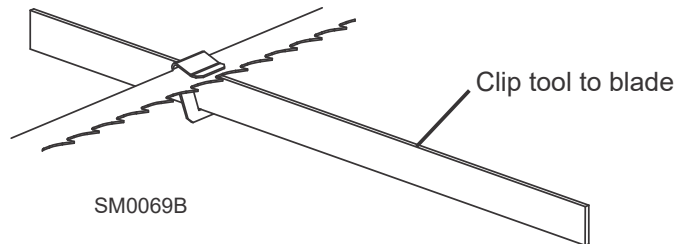

FIG. 7-38

3. Move the carriage so that the front end of the tool is positioned above the bed rail. Measure the distance from the bed rail to the bottom edge of the tool.
4. Move the carriage so that the back end of the tool is positioned above the bed rail. Measure the distance from the bed rail to the bottom edge of the tool.
5. If the measurement from the tool to the bed rail is not equal within 1/32" (.75 mm), adjust the vertical tilt of the outer blade guide roller.
6. Loosen one set screw at the side of the blade guide assembly.

See Figure 7-39. Loosen the jam nuts on the top and bottom vertical tilt adjustment screws. To tilt the roller up, loosen the bottom screw and tighten top screw. To tilt the roller down, loosen the top screw and tighten the bottom screw. Tighten the jam nuts and recheck the tilt of the blade.

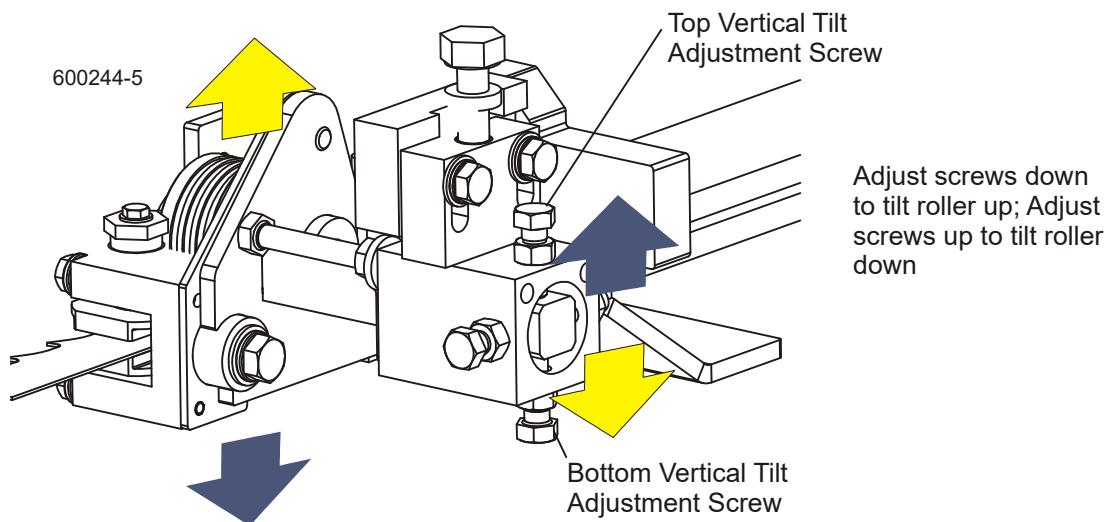

FIG. 7-39

7. Move the blade guide alignment tool close to the inner blade guide roller assembly and repeat the above steps. Adjust the vertical tilt of the inner blade guide if necessary.

- After adjusting the vertical tilt of the blade guides, recheck the blade deflection and adjust if necessary.

Blade Guide Horizontal Tilt Adjustment

If the blade guides are tilted in the wrong direction horizontally, the back of the blade may contact the flange as the roller is spinning down, causing it to push the blade away from the guide roller.

- Remove the blade guide alignment tool from the blade and adjust the blade guide arm halfway in.
- Remove the clip from the blade guide alignment tool. Place the tool against the face of the outer blade guide roller.

See Figure 7-40.

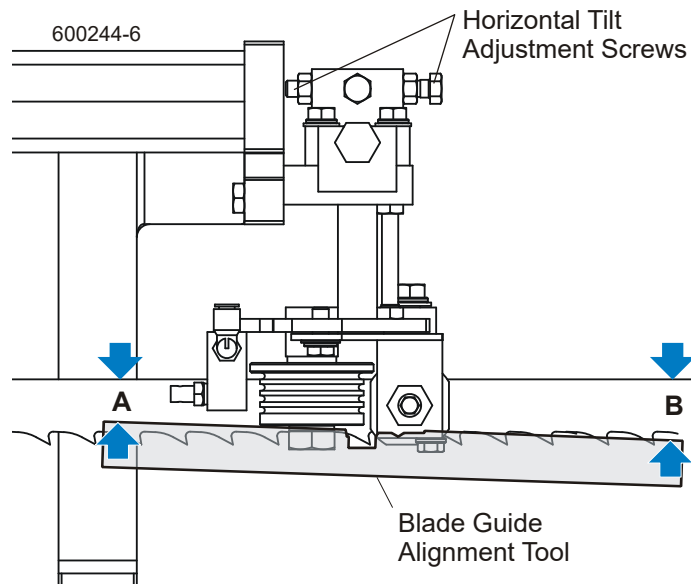

FIG. 7-40

- Measure between the back edge of the blade and the tool at the end closest to the inner blade guide ("B").
- Measure between the back edge of the blade and the other end of the tool ("A").

The roller should be tilted slightly to the left ('A' 1/8" [3 mm] less than 'B' \pm 1/8" [3 mm]).

- Loosen the jam nuts on the horizontal tilt adjustment screws. To tilt the roller left, loosen the right screw and tighten left screw. To tilt the roller right, loosen the left screw and tighten the right screw. Tighten the jam nuts and recheck the tilt of the blade. Repeat the above steps for the inner blade guide roller assembly.

7 Sawmill Alignment

Blade Guide Flange Spacing

NOTE: Once the blade guides have been adjusted, any cutting variances are most likely caused by the blade. [See Blade Handbook, Form #600.](#)

Blade Guide Flange Spacing

Each blade guide must be adjusted so the roller flange is the correct distance from the back edge of the blade. If the flange is too close to or too far from the blade, the sawmill will not cut accurately.

HINT: When adjusting blade guide spacing, loosen the top set screw and one side set screw only. This will ensure horizontal and vertical tilt adjustments are maintained when the adjustment screws are retightened.

1. Measure the distance between the flange on the outer blade guide roller to the back edge of the blade. This distance should measure 1/8" (3.0 mm). Adjust the roller back or forward if necessary.

See Figure 7-41. Loosen the top and one side screw shown. Back the stop bolt out of the way if necessary. Tap the blade guide forward or backward until properly positioned. Retighten the screws and jam nuts. Adjust the stop bolt against the blade guide assembly.

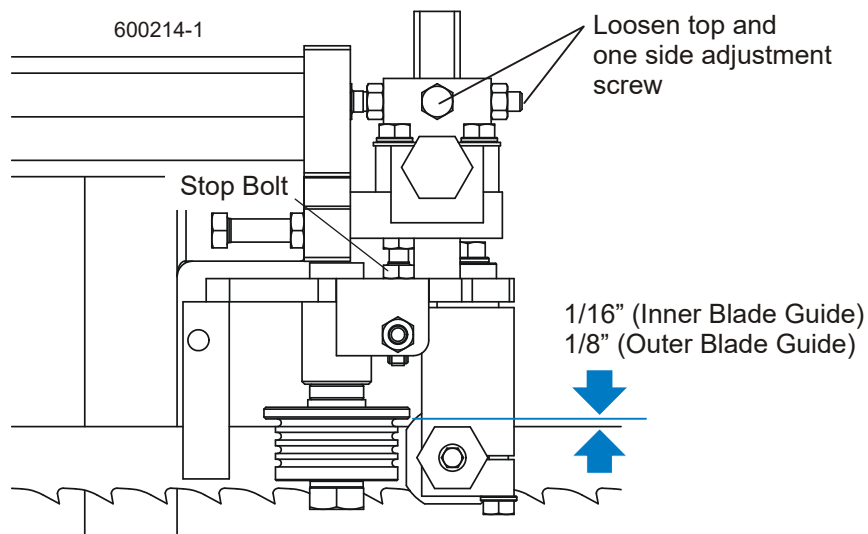

FIG. 7-41

2. Measure the distance between the flange on the inner blade guide roller to the back edge of the blade. This distance should measure 1/16" (1.5 mm). Adjust the roller back or forward if necessary.

Blade Guide Level

Perform the following adjustments to make sure the blade guide assembly is parallel to the blade.

1. Loosen the alignment bar mounting bolt. Use the provided bottom block adjustment tool to adjust the alignment bar up so the bar is close to, but not touching the bottom of the blade. Retighten the alignment bar mounting bolt
2. Check that the gap from the alignment bar to the blade is the same along entire length of the bar. Shine a flashlight behind the blade guide assembly to help you see the gap between the bar and the blade.

Rev. B4.11+: To adjust, turn the tilt adjustment jam nuts to pivot the block assembly until the alignment bar is parallel to the blade. Retighten the jam nuts. Repeat for the second blade guide assembly.

See Figure 7-42.

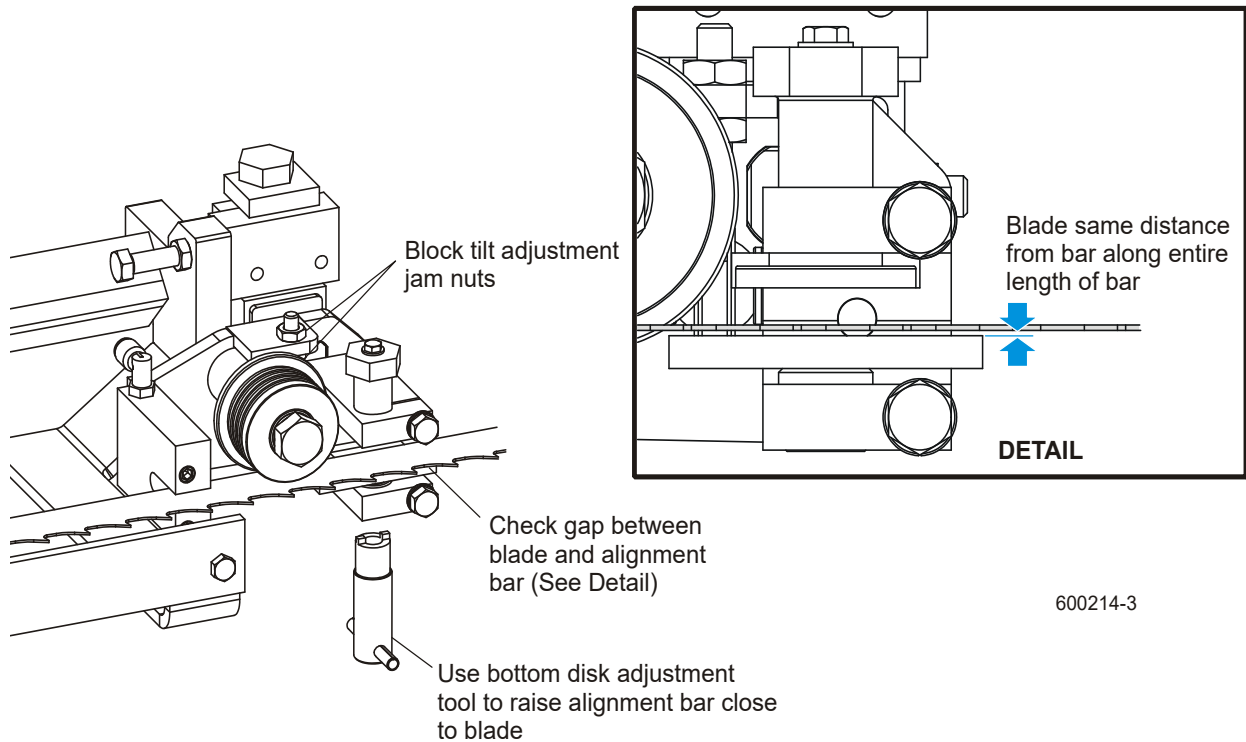

FIG. 7-42

Rev. B3.02 - B4.10: To adjust, loosen the block tilt clamp bolt to pivot the block assembly until the alignment bar is parallel to the blade. Retighten the clamp bolt. Repeat for the second blade guide assembly.

7 Sawmill Alignment

Blade Block Adjustment

See Figure 7-43.

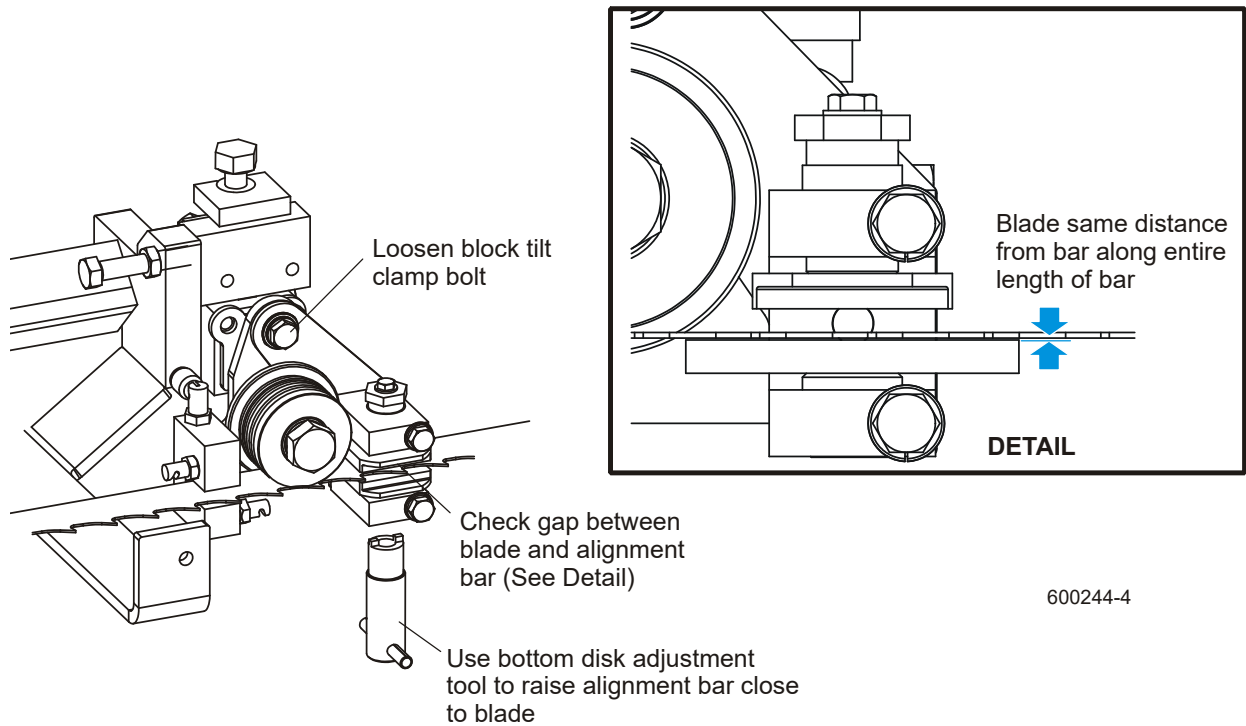

FIG. 7-43

Blade Block Adjustment

1. Remove the blade and remove the alignment bars from the blade guide assemblies. Install new or reconditioned bottom guide blocks to both blade guide assemblies (leave

mounting bolts loose). Use the provided bottom block adjustment tool to lower the bottom block all the way down. Install, tension and track the blade.

See Figure 7-44.

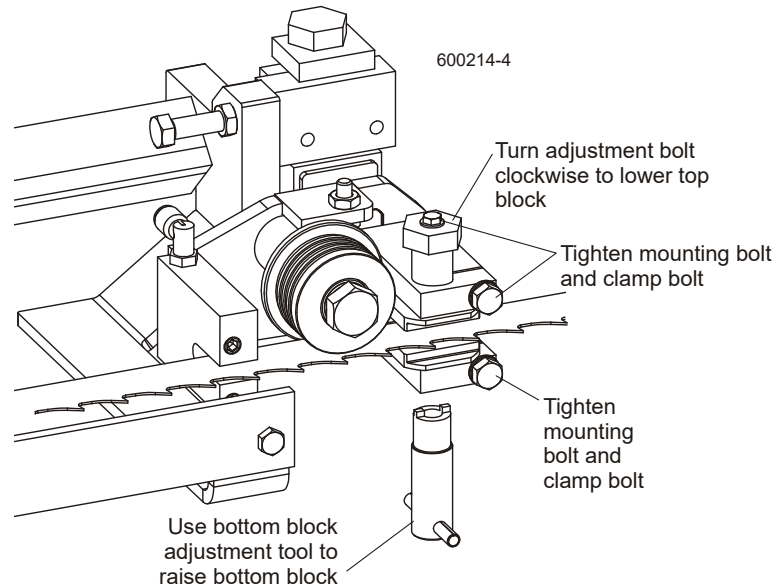

FIG. 7-44 REV. B4.11+

See Figure 7-45.

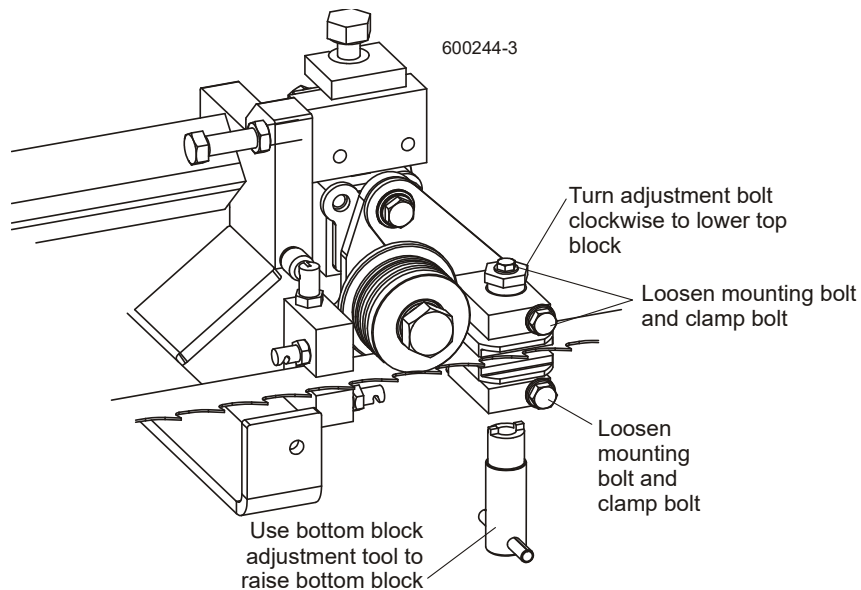

FIG. 7-45 REV. B3.02 - B4.10

2. Use the bottom block adjustment tool to raise the bottom block to 0.008" - 0.010" (0.2-0.25mm) from the blade. Use the provided shim to set the distance from the block to the blade. Tighten the bottom block mounting bolt and clamp bolt.

7 Sawmill Alignment

Manual Side Support Alignment

3. Turn the top block adjustment bolt clockwise to lower the top block to 0.008" - 0.010" (0.2-0.25mm) from the blade (using the shim as a guide). Tighten the top block mounting bolt and clamp bolt.
4. After tightening the clamp bolt, recheck the distance from the top block to the blade and readjust if necessary.

Manual Side Support Alignment

Logs and boards are clamped against the side supports when sawing. The side supports must be square to the bed to ensure square lumber.

1. Swing a side support down and measure between the face of the support and the main bed tube. The distance at the top of the side support ('B') should be equal to or no more than 1/32" (0.8 mm) greater than the distance at the base of the side support ('A'). Adjust the horizontal tilt of the side support if necessary.

See Figure 7-46. Loosen the two adjustment plate mounting bolts. Use a mallet to move the plate until the side support is parallel to the bed tube in the horizontal position. Retighten the mounting bolts.

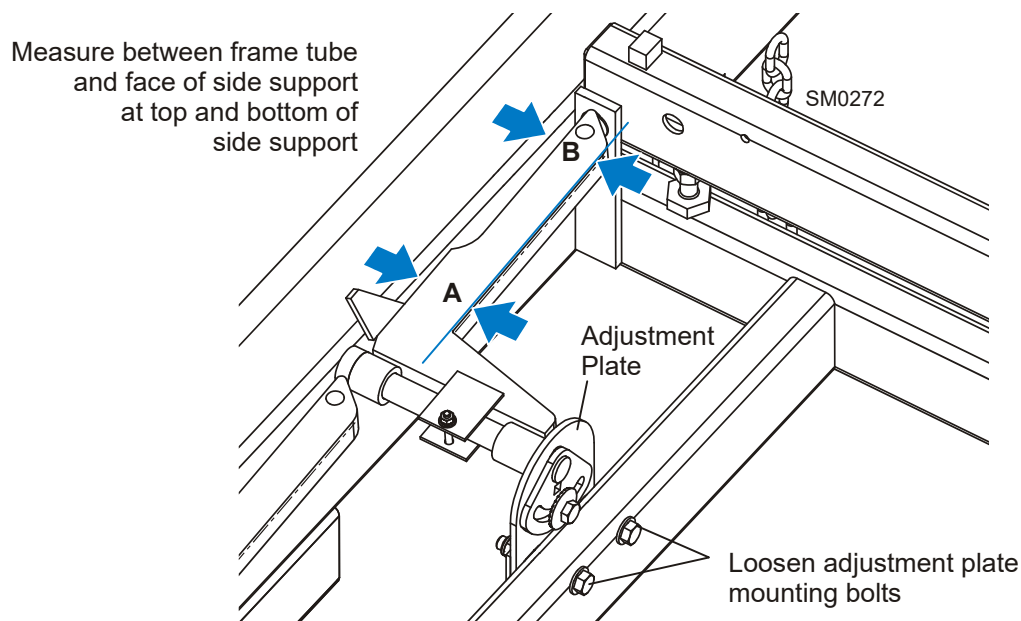

FIG. 7-46

2. Repeat the horizontal check for the remaining side supports. Adjust as necessary.
3. Place square alignment tubes (Part No. S12831 - 2 required) across the bed rails. Swing a side support up so that it is vertical.

4. Pull back at the top of the support to eliminate slack as if a log were being clamped against it.
5. Place a square against the face of the side support. The side support should be square or slightly tilted forward $1/32$ " (0.8 mm). Adjust the vertical tilt of the side support if necessary.

See Figure 7-47. Loosen the side support mounting bolt. Use a $3/8$ " ratchet to rotate the pin until the side support is square to the bed.

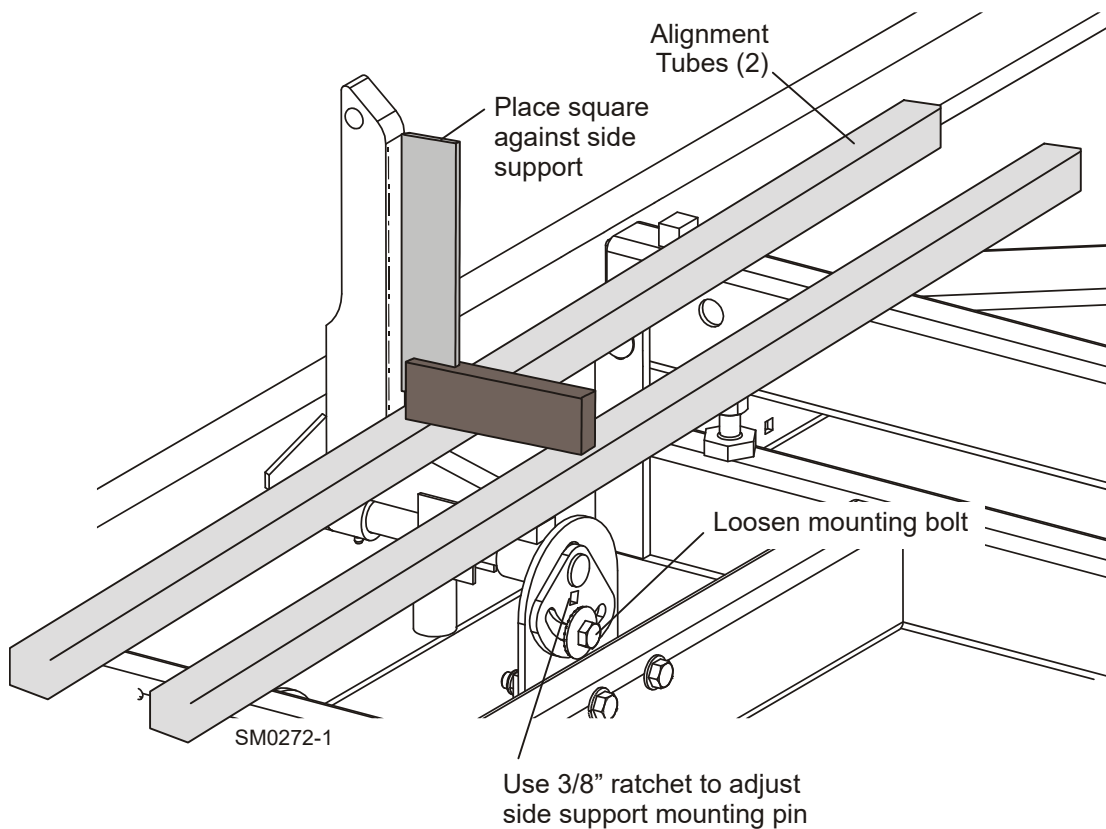

FIG. 7-47

6. Repeat the vertical check for the remaining side supports and adjust as necessary.

Hydraulic Side Support Alignment

Place the square against the face of the side support. The side support should be square or slightly tilted forward $1/32$ " (0.8 mm). Adjust the vertical tilt of the side support if necessary.

7

Sawmill Alignment

Clamp Stop/Stop Bolt Adjustment

See **Figure 7-48**. Loosen the top jam nut. Adjust the two lower jam nuts up to tilt the side support back. Adjust the two lower jam nuts down to tilt the side support forward. Retighten the top jam nut and repeat for the other hydraulic side support.

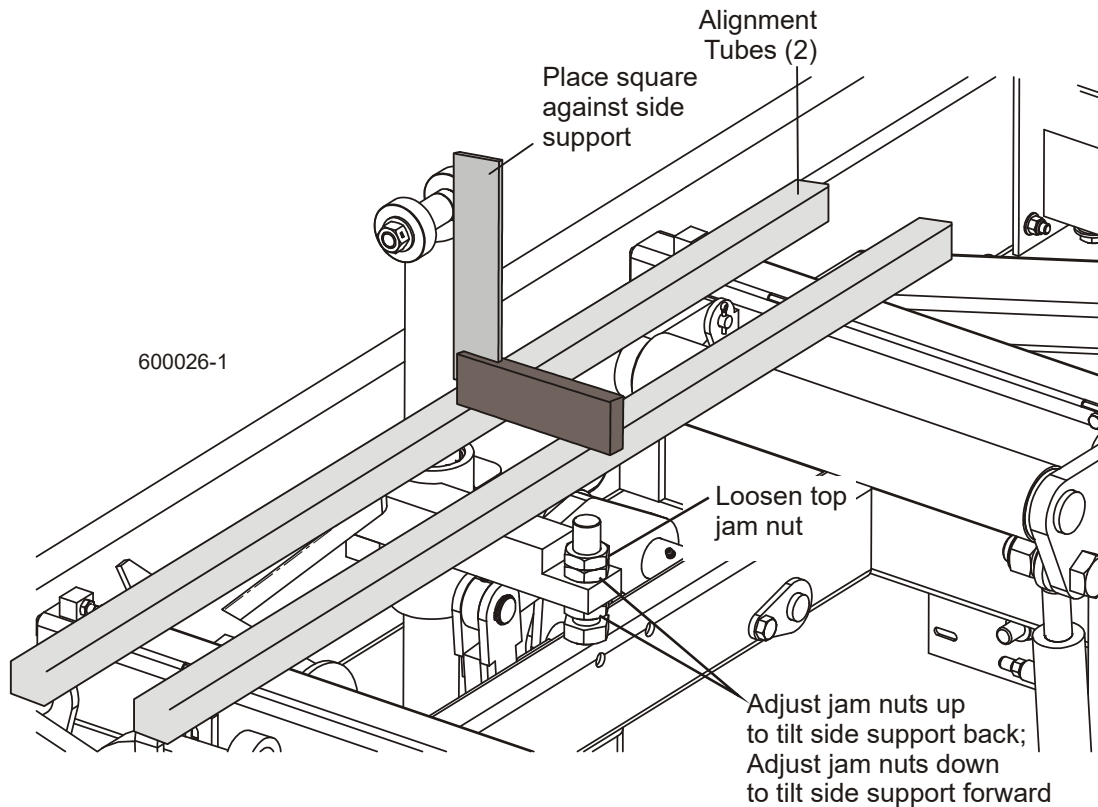

FIG. 7-48

Clamp Stop/Stop Bolt Adjustment

1. Once the side supports are aligned, pivot them down to their horizontal position.
2. Tie a string to the stop block at the first bed rail. Stretch the string toward the rear of the frame and tie to the stop block at the last bed rail.

See **Figure 7-49**. Loosen the clamp stop bolts and adjust the clamp stop until it touches the string. Loosen the jam nut and adjust the bolt on the middle-rear bed rail until it touches the string.

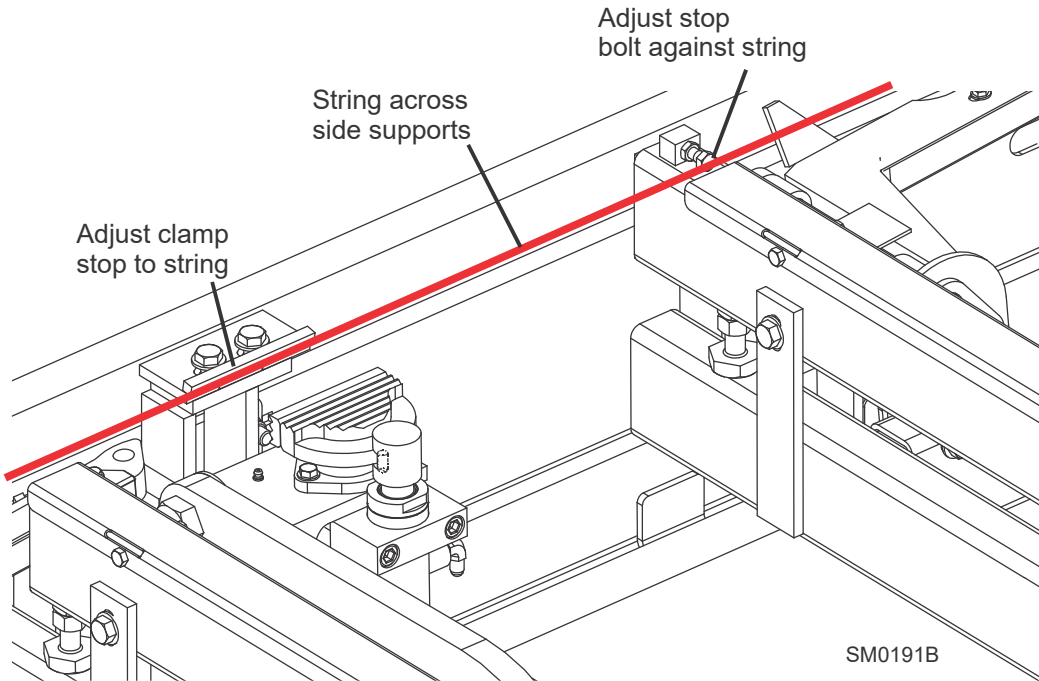

FIG. 7-49

Saw Head Tilt

As the blade enters a wide log or cant, the outside of the saw head will drop down slightly. To compensate for the drop, the saw head is adjusted 1/16" (1.5 mm) higher at the outside.

7 Sawmill Alignment

Saw Head Tilt

1. Move the saw carriage so the blade is positioned over a bed rail. Adjust the blade guide arm to 1/2" (13 mm) from full open. The saw head should still be adjusted so the blade is 14 3/4" (375 mm) above the bed rails.

See Figure 7-50.

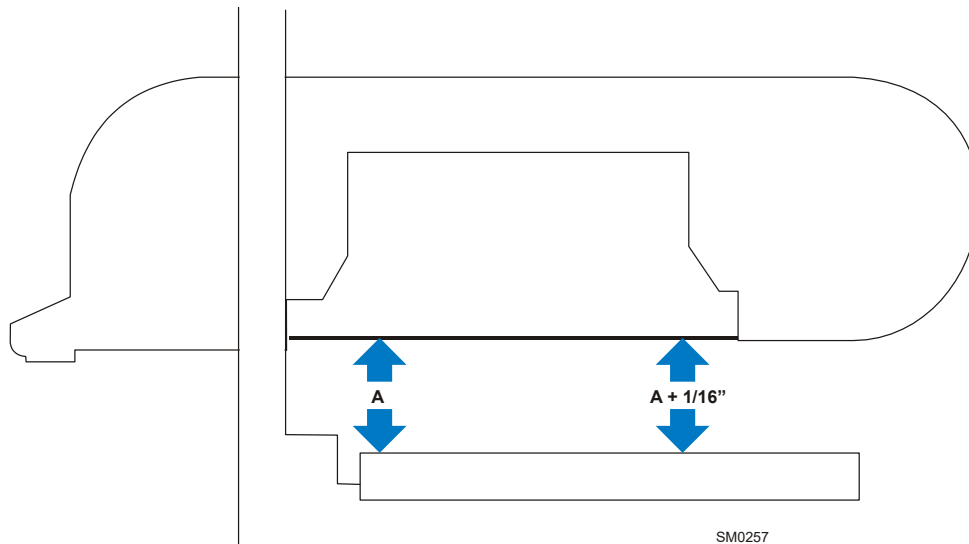
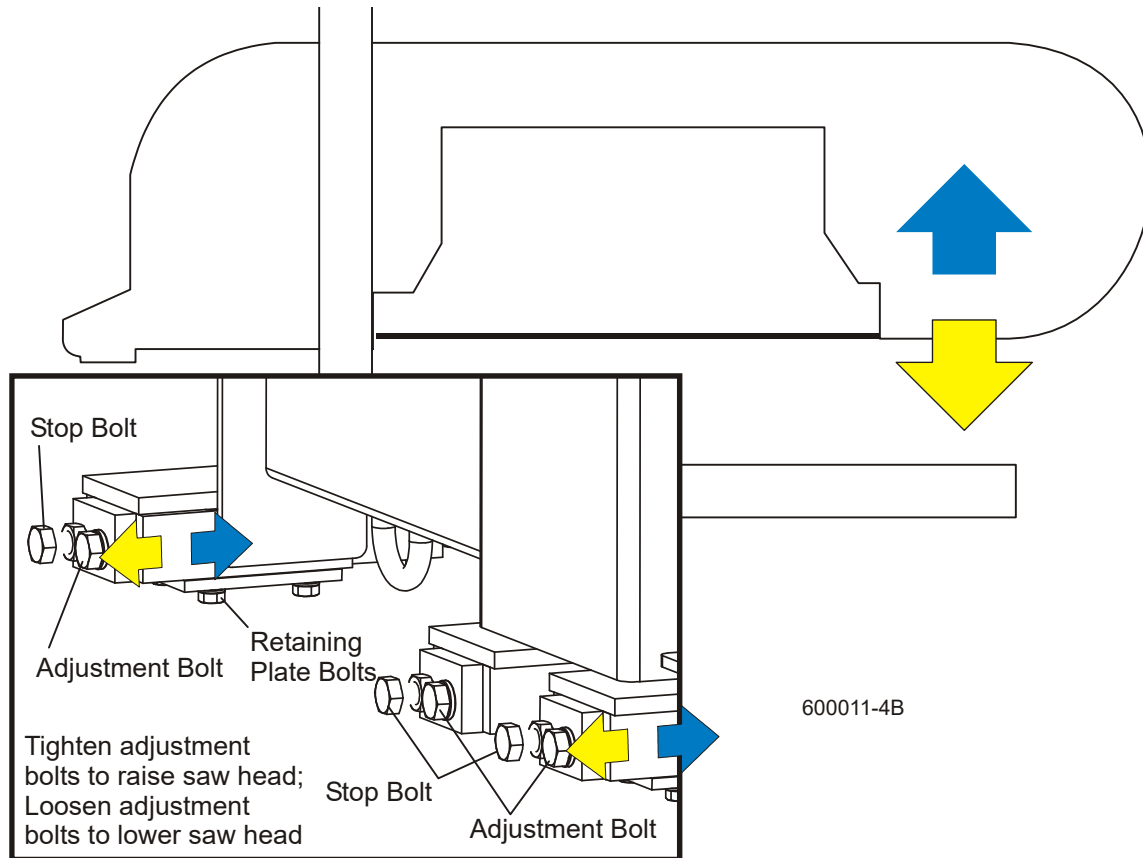

FIG. 7-50

2. Measure from the blade to the bed rail near the outer blade guide assembly.

See Figure 7-51. To adjust the saw head tilt, use the bolts located at the bottom of the saw head mast. Loosen the two sets of four retaining plate bolts. To raise the outside of the saw head, back the stop bolts out, then tighten the adjustment bolts. To lower the outside of the saw head, loosen the adjustment bolts and tighten the stop bolts. Recheck the measurement from the blade to the bed rails and adjust the stop bolts and adjustment

bolts until the outside of the saw head is $\frac{1}{16}$ " higher than the inside. Retighten the retaining plate bolts.



DETAIL OF LOWER TRACK ROLLER ASSEMBLY

FIG. 7-51

Blade Height Scale Adjustment

After the entire sawmill has been aligned and all adjustments made, check that the blade height scale indicates the true distance from the blade to the bed rails.

1. Move the saw carriage so the blade is positioned directly above one of the bed rails. Measure from the bottom edge on a down-set tooth of the blade to the top of the bed rail, near the inner blade guide assembly.
2. View the blade height scale with eyes level with the indicator. The scale should indicate the actual distance from the blade to the bed rail. Adjust the indicator if necessary.

See Figure 7-52. Loosen the scale bracket mounting bolts. Adjust the bracket up or down until the indicator is aligned with the correct mark on the scale (+0 - $\frac{1}{32}$ [0.8 mm]). Retighten the bracket mounting bolts.

7 Sawmill Alignment

Blade Height Scale Adjustment

For example, if the measurement from the down-set tooth of the blade to the bed rail was $14 \frac{3}{4}$ " (375 mm), make sure the indicator reads $14 \frac{3}{4}$ " (375 mm) on the scale.

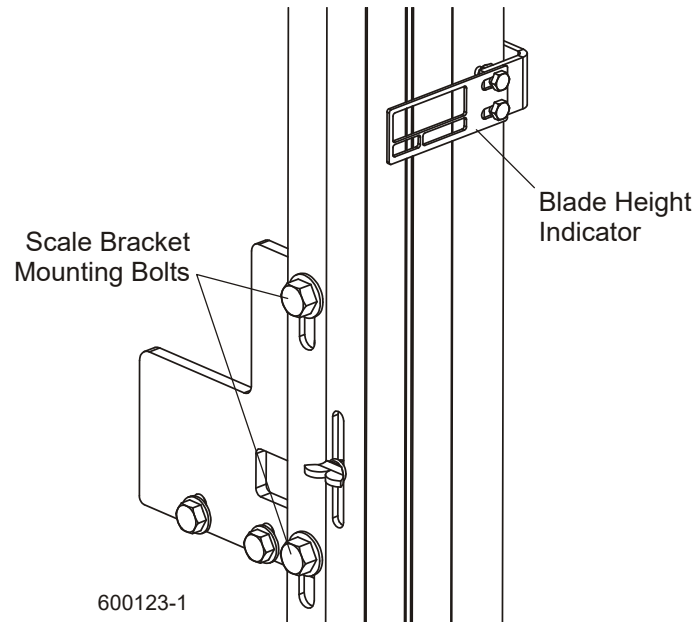
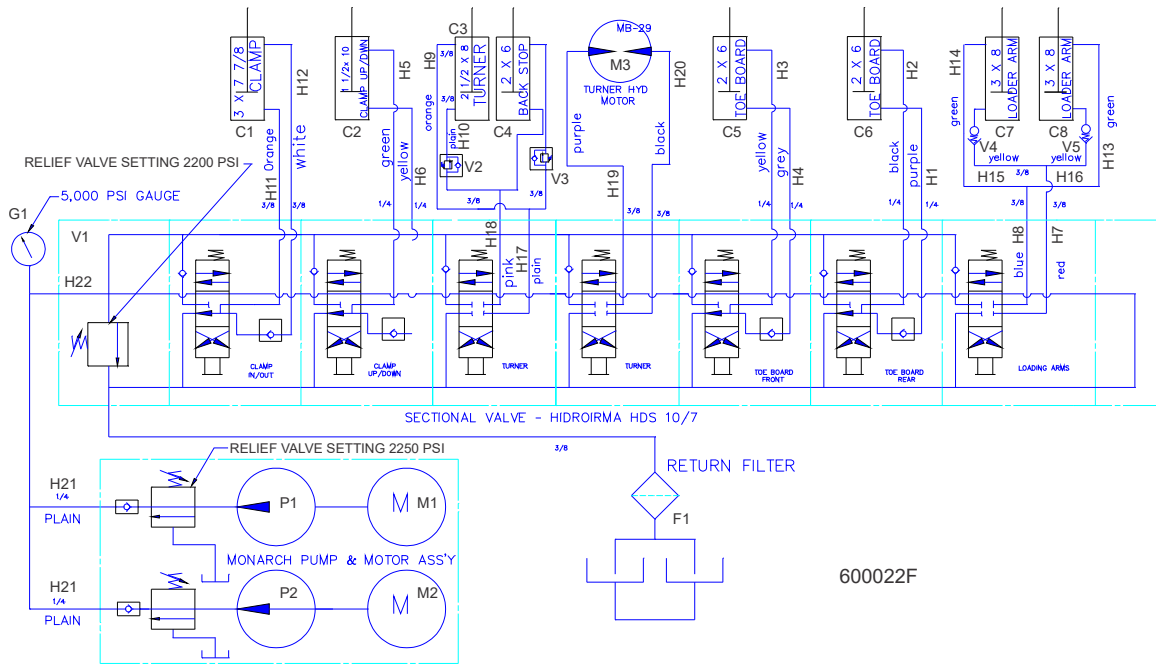

FIG. 7-52

SECTION 8 HYDRAULIC INFORMATION

8.1 Hydraulic Schematic



HYDRAULIC SCHEMATIC (DC MODELS)

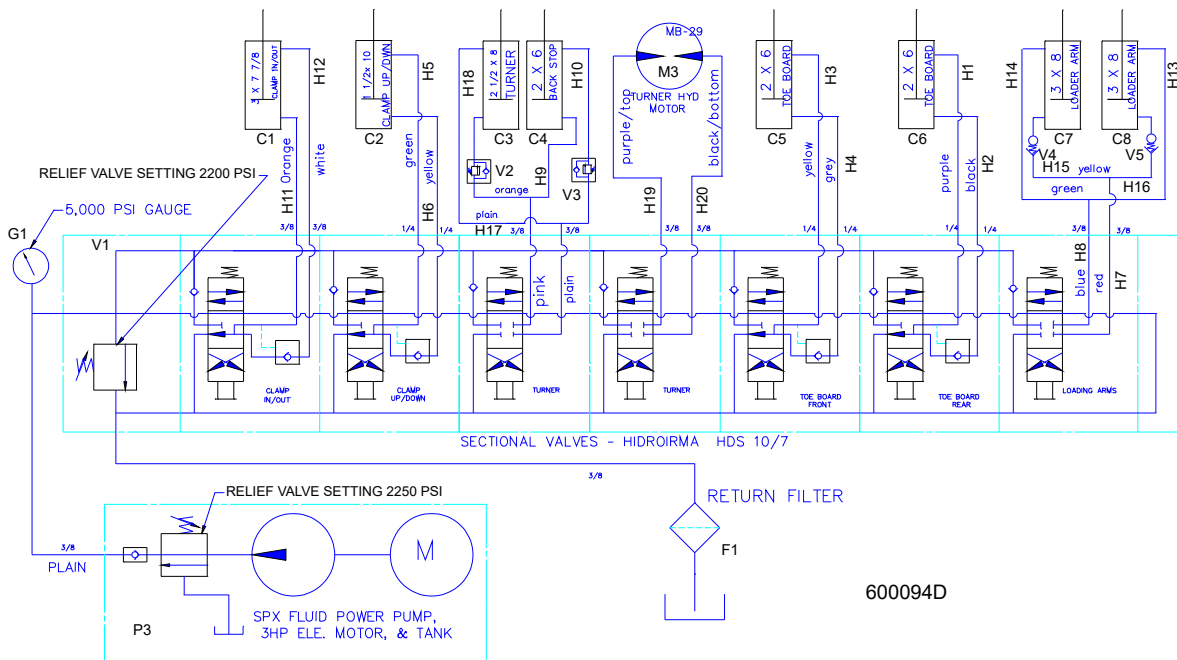

HYDRAULIC SCHEMATIC (AC MODELS)

8.2 Hydraulic Layout Diagram

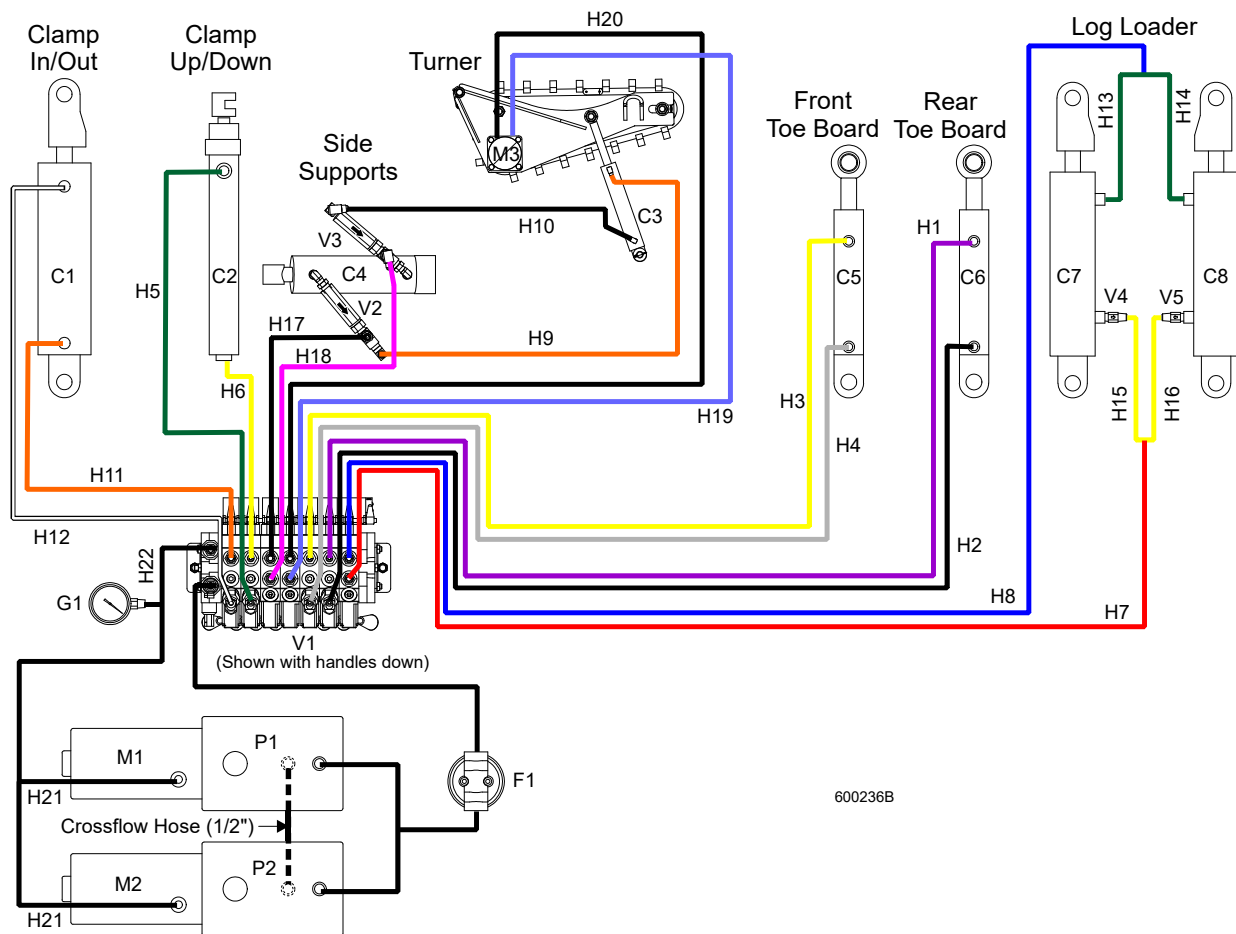

HYDRAULIC LAYOUT DIAGRAM (DC ONLY).

8.3 Hydraulic Components

ID	Wood-Mizer Part.#	Description
C1	017275	Hyd. Cylinder, 3" Bore X 7" Stroke
C2	015050	Hyd. Cylinder, 1 1/2" Bore X 10" Stroke
C3	034267	Hyd. Cylinder, 2" Bore x 10" Stroke
C4	034736	Hyd. Cylinder, 2 1/2" Bore X 6" Stroke
C5, C6	014482	Hyd. Cylinder, 1 1/2" Bore x 6" Stroke
C7, C8	042754	Hyd. Cylinder, 3" Bore X 8" Stroke
F1	P20301	Filter, Hydraulic Fluid Cartridge
G1	P10052	Gauge, 5000 PSI Hydraulic
P1, P2	P12701	Hydraulic Pump, With Motor (DC)
P3	038963	Hyd. Pump/Tank/Motor (230/460 AC)
	034794	Hydraulic Pump/Tank/Motor (575VAC)
V1	034451	Valve, 7-Section Hydraulic
V2, V3	015484	Sequence Valve, 700 psi
V4, V5	038734	Valve, Hydraulic 6.5GPM Velocity Fuse
M1, M2	052807	Motor, Iskra Hydraulic Pump (DC)
M3	007331	Motor, Hydraulic Log Turner Chain

8.4 Hydraulic Hoses

ID	Color Code	LENGTH "A"	Application	HOSE PART #
H1	Purple	197"	1/4" Rear Toe Board Top (LT60HD)	014791
		219"	1/4" Rear Toe Board Top (LT70HD)	018026
H2	Black	197"	1/4" Rear Toe Board Base (LT60HD)	014791
		219"	1/4" Rear Toe Board Base (LT70HD)	018026
H3	Yellow	95"	1/4" Front Toe Board Top (LT60HD)	P12540
		117"	1/4" Front Toe Board Top (LT70HD)	P12542
H4	Gray	95"	1/4" Front Toe Board Base (LT60HD)	P12540
		117"	1/4" Front Toe Board Base (LT70HD)	P12542
H5	Green	182"	1/4" Clamp Up/Down Top (LT60HD)	014788
		204"	1/4" Clamp Up/Down Top (LT70HD)	014792
H6	Yellow	171"	1/4" Clamp Up/Down Base (LT60HD)	P12549
		193"	1/4" Clamp Up/Down Base (LT70HD)	015692
H7	Red	156"	3/8" Loading Arm Base (LT60HD)	048290
		178"	3/8" Loading Arm Base (LT70HD)	048291
H8	Blue	156"	3/8" Loading Arm Top (LT60HD)	048290
		178"	3/8" Loading Arm Top (LT70HD)	048291
H9	Orange	65"	3/8" Side Support Base	048292
H10	Plain	73"	3/8" Side Support Top	048293
H11	Orange	181"	3/8" Clamp In/Out Base (LT60HD)	048294
		177"	3/8" Clamp In/Out Base (LT70HD)	048295
H12	White	129"	3/8" Clamp In/Out Top (LT60HD)	048296
		151"	3/8" Clamp In/Out Top (LT70HD)	048297
H13	Green	38"	3/8" Loading Arm Branch Top	006875
H14	Green	77"	3/8" Loading Arm Branch Top	048298
H15	Yellow	81"	3/8" Loading Arm Branch Base	048299
H16	Yellow	43"	3/8" Loading Arm Branch Base	048300
H17	Plain	159"	3/8" Log Turner Base (LT60HD)	048301
		181"	3/8" Log Turner Base (LT70HD)	048294
H18	Pink	159"	3/8" Log Turner Top (LT60HD)	048301
		181"	3/8" Log Turner Top (LT70HD)	048294
H19	Purple	164"	3/8" Log Turner Motor Top (LT60HD)	048302
		177"	3/8" Log Turner Motor (LT70HD Nearest Frame)	006723
H20	Black	163"	3/8" Log Turner Motor Base (LT60HD)	048304
		180"	3/8" Log Turner Motor (LT70HD Furthest from Frame)	006724
H21	Plain	15"	1/4" Pump To Valve (two hoses)	057964
H22	Plain	6 1/2"	3/8" Gauge To Valve	036303

INDEX

A

- alignment
 - lower track rollers 7-21
 - main bed rails 7-24
 - slide pad adjustment 7-21
- autoclutch option
 - operation 4-8

B

- battery
 - troubleshooting problems 6-4
- belt
 - tension 5-30
- blade
 - breakage, troubleshooting 6-1
 - installation 3-6
 - tensioning 3-8
 - tracking 3-13
- blade guide arm
 - operation 4-7

C

- chain
 - feed tension 5-26
 - maintenance 5-9
 - up/down tension 5-21
- clamping logs 4-5

H

- hydraulic
 - component list 8-3
 - control operation 4-1, 4-4
 - fluid level 5-19
 - hose list 8-4
 - layout diagram 8-2
 - schematic 8-1
 - troubleshooting problems 6-11

L

- leveling logs 4-5
- loading logs 4-4

M

- maintenance
 - autoclutch belt (DC only) 5-18
 - blade guide 5-2
 - blade tensioner 5-10
 - blade wheel belts 5-13
 - carriage track/wipers 5-5
 - drive belt 5-14
 - drum switches 5-8
 - hydraulic system 5-19
 - mast rails 5-6, 5-7
 - miscellaneous 5-9
 - part wear life 5-1
 - power feed 5-26
 - sawdust removal 5-4
 - turner chain 5-30
 - up/down 5-21

O

- operation
 - edging 4-12
 - sawing 4-11

P

power feed
 mechanical troubleshooting test 6-10
 operation 4-10
 speed adjustment 4-9
 troubleshooting problems 6-7

S

safety
 symbols 2-1

scale
 blade height operation 4-14
 inch height 4-14
 quarter inch 4-15

service information
 branch locations 1-3
 customer & sawmill ID 1-7
 general contact info 1-2

setup
 portable sawmill 3-3
 stationary sawmill 3-1

switch
 power feed & up/down maintenance 5-8

T

tensioner
 maintenance 5-12

troubleshooting 6-1
 electrical problems 6-3
 hydraulic problems 6-11
 power feed problems 6-7
 sawing problems 6-1

turning logs 4-5

U

up/down
 operation 4-6
 troubleshooting problems 6-3

W

water lube
 operation 4-16