

**Power Feed Trim Saw
Safety, Operation,
Maintenance & Parts Manual**

PC200

rev. A1.00-A1.09

Safety is our #1 concern!

March 2023

Form #2380

Models Affected:

PC200A10
PC200B10
PC200C10
PC200H10



WARNING! Read and understand this manual before using this machine.

California

Proposition 65 Warning



WARNING: Drilling, sawing, sanding or machining wood products can expose you to wood dust, a substance known to the State of California to cause cancer. Avoid inhaling wood dust or use a dust mask or other safeguards for personal protection.

For more information go to **www.P65Warnings.ca.gov/wood**.

Active Patents assigned to Wood-Mizer, LLC

Wood-Mizer, LLC has received patents that protect our inventions which are a result of a dedication to research, innovation, development, and design. Learn more at: woodmizer.com/patents

©2023 Wood-Mizer LLC

Printed in the United States of America, all rights reserved. No part of this manual may be reproduced in any form by any photographic, electronic, mechanical or other means or used in any information storage and retrieval system without written permission from

Wood-Mizer, LLC

8180 West 10th Street

Indianapolis, Indiana 46214

PC200 Power Trim Saw

SECTION 1 INTRODUCTION

1.1	About This Manual.....	1-1
1.2	Getting Service.....	1-1
1.3	Specifications	1-1
1.4	Specifications	1-1

SECTION 2 SAFETY

2.1	Safety Symbols.....	2-1
2.2	Safety Instructions.....	2-1
	<i>Observe ALL Safety Instructions.....</i>	2-1
	<i>Keep Work Area Clean</i>	2-2
	<i>Wear Safety Clothing (Personal Protection Equipment).....</i>	2-2
	<i>Always use guards.....</i>	2-2
2.3	Electrical Lockout Procedures.....	2-2
2.4	2-4

SECTION 3 OPERATION

3.1	Site Preparation	3-1
3.2	Onsite setup/assembly	3-1
	<i>Outfeed Panel Assembly.....</i>	3-1
	<i>Assemble the Board Stop Assembly</i>	3-2
3.3	Controls	3-3
3.4	Operation	3-3

SECTION 4 MAINTENANCE

4.1	Lubrication	4-1
4.2	Blade change	4-1
4.3	Drive belt.....	4-2
4.4	Chain Maintenance.....	4-4

SECTION 5 REPLACEMENT PARTS

5.1	How To Use The Parts List	5-1
	<i>To Order Parts</i>	5-1
5.2	Sample Assembly	5-1
5.3	Torque Values	5-2
5.4	Torque (Part A).....	5-3
5.5	Frame (Part B).....	5-5
5.6	Blade Cover.....	5-6
5.7	Board Stop Assembly	5-7
5.8	Stop Assemblies	5-8

Table of Contents

Section-Page

5.9	Chain Drive System.....	5-9
5.10	Idle Chain System.....	5-10
5.11	Motor Assembly	5-11
5.12	Control Assembly, PC200EA 240V 1Ph	5-12
5.13	Control Assembly, PC200EB 240V 3Ph	5-14
5.14	Insert Panel Assembly, PC200 240V 3Ph	5-16
5.15	Control Assembly, PC200EB 240V 3Ph	5-18
5.16	Insert Panel Assembly, PC200 240V 3Ph	5-20
5.17	Blade Assembly	5-22

Wood-Mizer® LLC Limited Product Warranty



Wood-Mizer LLC ("Warrantor"), an Indiana corporation with its principal place of business at 8180 West Tenth Street, Indianapolis, IN 46214-2400 USA, warrants to the purchaser ("Purchaser") that for the time periods specifically stated herein and subject to the terms, conditions and limitations stated herein, the equipment manufactured by the Warrantor will be free from defects in material and workmanship attributable to Warrantor so long as, during the warranty periods stated herein, the equipment is installed, operated and maintained in accordance with the instructions provided by Warrantor.

PRODUCT	MODEL CLASS	LENGTH OF WARRANTY		EFFECTIVE DATE
		USA & CANADA	NON USA & CANADA	
Portable Sawmills, Resaws, Edgers	LT, LX, HR, EG	Two years	One year	Date of purchase
Portable Sawmills with Chassis	LT28, LT35, LT40, LT50, LT70, LX450	Two years, excluding the chassis, which chassis shall have a five year warranty	One year	
Industrial Sawmills, Resaws, Edgers	WM, HR, EG, TVS, SVS	One year	One year	Date of purchase or date of installation / training (if applicable), whichever occurs first, not to exceed 6 months from date of purchase
TITAN Industrial	WB, TV, HR, EG, EA, MR	One year	One year	
Material Handling	TWC, IC, TD, LD, GC, CR, CB, CC	One year	One year	
Blade Maintenance Equipment	BMS, BMT, BMST	One year	One year	Date of purchase
Options and Accessories	Various	One year*	One year*	
Moulders, Extractors	MP, MD	Two years	One year	
Kilns	KS, KD	One year	One year	
Slab Flatteners	MB	Two years	One year	
Pallet Equipment	PD, PC	One year	One year	
Log Splitters	FS	One year	One year	
Replacement Parts	Various	90 days	90 days	

* Warranty on Options will match the warranty on the primary equipment when purchased on same invoice.

Exclusions from 90 Day, Limited One Year and Two Year Warranty

Warrantor shall have no responsibility under this warranty for any wear components, including, but not limited to: belts, blade guides, blades, electric motor brushes, drum switches, filters, fuses, hoses, bearings (excluding cylindrical drive bearings), bushings, cable carriers, and spark plugs. All wear components are furnished "as is", without any warranty from Warrantor. This limited warranty does not cover any defects caused by misuse, negligence, alterations, damage due to overload, abnormal conditions, excessive operation, accident, or lack of performance of normal maintenance services.

Several components which are used in the manufacture of the equipment but not manufactured by Warrantor such as cant hooks, power plants, laser sights, batteries, tires, and trailer axles have warranties provided by the original equipment manufacturer (written copies available upon request). Warrantor does not separately warrant such items. Components or equipment manufactured by third parties are not covered by this warranty. Warrantor, however, will provide reasonable assistance to the Purchaser to make claims against any warranties applicable to such component parts as provided by such original equipment manufacturers. Components or equipment manufactured by third parties are not covered by this Warranty.

Five Year Limited Chassis Warranty

The limited five year chassis warranty described above, DOES NOT extend to (a) any damage stemming from accident, improper towing, overload, abuse, misuse, abnormal conditions, negligence, excessive operation, or lack of maintenance, (b) rust caused by exposure to corrosive atmospheric conditions, or (c) the sawmill head, carriage, axle, brakes, or any hydraulic or electrical components attached to the chassis.

Warrantor's Obligations as To Defects

In the event that the equipment fails to perform due to defective materials or workmanship attributable to Warrantor under normal use and service within the established warranty period, Purchaser's sole and exclusive remedy and Warrantor's sole liability shall be to replace or repair, in Warrantor's sole and subjective discretion, any defective part at Warrantor's principal place of business without cost to the Purchaser if such defect exists. The determination of whether a product is defective shall be made by Warrantor in Warrantor's sole and subjective discretion. The Purchaser must notify Warrantor prior to shipping any defective part. Warrantor, at its sole discretion, may cover expenses incurred in shipping the defective part to Warrantor for evaluation; provided, however, that Warrantor will not be responsible for labor, travel time, mileage, removal, installation or incidental or consequential damages. However, any part in excess of 140 pounds must be returned by the Purchaser, to the Warrantor's nearest authorized facility at the Purchaser's expense, if return is requested by Warrantor. Warrantor shall have a reasonable time within which to replace or repair the defective part. If Warrantor determines that the product is not defective under the terms of this warranty in Warrantor's sole and subjective discretion, then Purchaser shall be responsible for any expenses incurred by Warrantor in returning the equipment to the Purchaser.

Limitations and Disclaimers of Other Warranties

EXCEPT FOR THE EXPRESS WARRANTY PROVISIONS STATED ABOVE, WARRANTOR DISCLAIMS ALL WARRANTIES, EXPRESS AND/OR IMPLIED, INCLUDING WITHOUT LIMITATION, THE IMPLIED WARRANTIES OF MERCHANTABILITY, AND FITNESS FOR A PARTICULAR PURPOSE, NON-INFRINGEMENT AND TITLE. No representation or other affirmation of fact by representatives of Warrantor, whether verbal or in writing, including photographs, brochures, samples, models, or other sales aids, shall constitute a warranty or other basis for any legal action against Warrantor. There are no other representations, promises, agreements, covenants, warranties, guarantees, stipulations or conditions, express or implied, by Warrantor except as expressly set forth herein. THE ORIGINAL PURCHASER AND ANY INTENDED USER OR BENEFICIARY OF THIS EQUIPMENT, SHALL NOT BE ENTITLED TO RECOVER ANY INDIRECT, SPECIAL, PUNITIVE, EXEMPLARY, CONSEQUENTIAL, SPECIAL, OR INCIDENTAL DAMAGES OR LOSSES, INCLUDING BUT NOT LIMITED TO, DAMAGES OF LOST PRODUCTION, LOST REVENUE, LOST PRODUCT, LOST PROFITS, LOST BUSINESS, LOSS OF USE, LOSS OF GOODWILL, OR BUSINESS INTERRUPTION, FROM WARRANTOR FOR ANY REASON WHATSOEVER INCLUDING WITHOUT LIMITATION WARRANTY OR DEFECT IN THE PRODUCT REGARDLESS OF THE SOLE, JOINT AND/OR CONCURRENT NEGLIGENCE, BREACH OF CONTRACT, BREACH OF WARRANTY, STRICT LIABILITY IN TORT OR STATUTORY CLAIMS OR OTHER LEGAL FAULT OR RESPONSIBILITY OF EITHER WARRANTOR OR PURCHASER OR ITS EMPLOYEES OR AGENTS. Warrantor does not warrant that its equipment meets or complies with the requirements of any particular safety code or governmental requirements.

Defective items replaced under the terms of this warranty become the property of Warrantor.

Design Changes

Warrantor reserves the right to change the design of its products from time to time without notice and without obligation to make corresponding changes in or to its products previously manufactured.

Rights of Purchasers

The validity and effect of this limited warranty as well as its interpretation, operation and effect, shall be determined exclusively by the principles of law and equity of the State of Indiana, USA. This limited warranty gives Purchaser specific legal rights. Purchaser may also have other rights, which may vary from state to state. Some states may not allow limitations as to the duration of implied warranties or to the exclusion or limitation of incidental or consequential damages, so some of the limitations and exclusions detailed set forth above may not apply. In the event that any one or more of the provisions of this warranty shall be or become invalid, illegal or unenforceable in any respect, the validity, legality and enforceability of the remaining provisions of this warranty shall not be affected thereby.

Interpretations

This Warranty constitutes the entire warranty agreement between Warrantor and Purchaser and supersedes any prior understandings or agreements pertaining to the same subject matter. This warranty cannot be amended except in writing which refers to this warranty which is signed by both Warrantor and Purchaser.

SECTION 1 INTRODUCTION

1.1 About This Manual

This manual replaces any previous information received on your Wood-Mizer® equipment.

The information and instructions in this manual do not amend or extend the limited warranties for the equipment given at the time of purchase.

1.2 Getting Service

For contact information, sales, service, parts, and additional manuals, sign into your account on <https://woodmizer.com>, or call inside the USA: 1-800-553-0182 or from outside the USA: 317-271-1542

1.3 Specifications

Equipment specification are included in the Online Manuals, which are found at <https://apps.woodmizer.com/Manuals/Manuals.aspx?parent=0>.

1.4 Specifications

Saw Motor	10HP Electric 240V/60Hz 1-Phase 10HP Electric 240V/60Hz 3-Phase 10HP Electric 480V/60Hz 3-Phase
Min. Material	Length 21" (533 mm)
Max. Material	Length 66" (1.67 m) Width 10" (254 mm) Thickness 2" (50 mm)
Blade Design	Overhead 18" (457 mm) diameter carbide-tipped circular blade
Table Design	Gravity-assist inclined with 58"(1.47 m) drop height
Board stops	4 variable stops over a 45" (1140mm) space
Feed System	3 x #2060 roller feed chains with lugs and 12" (304 mm) spacing
Feed Speed	Variable from 0 - 1 foot/second
Feed Motor	½ HP with gear reduction

SECTION 2 SAFETY

2.1 Safety Symbols

The following symbols and signal words call your attention to instructions concerning your personal safety.



DANGER! indicates an imminently hazardous situation which, if not avoided, will result in serious injury or death.



WARNING! suggests a potentially hazardous situation which, if not avoided, could result in serious injury or death.



CAUTION! refers to potentially hazardous situations which, if not avoided, may result in minor or moderate injury or damage to equipment.

NOTICE indicates vital information.

2.2 Safety Instructions

OWNER/OPERATOR'S RESPONSIBILITY

The procedures listed in this manual may not include all ANSI, OSHA, or locally required safety procedures. **It is the owner/operator's responsibility and not Wood-Mizer LLC to ensure all operators are properly trained and informed of all safety protocols.** Owner/Operators are responsible for following all safety procedures when operating and performing maintenance to the equipment.

Observe ALL Safety Instructions

NOTICE Read the entire Operator's Manual before operating this equipment.

Note all safety warnings throughout this manual and those posted on the machine.

Be able to access this manual at all times while operating this equipment.

Read additional manufacturer's manuals and observe their applicable safety instructions.

Only persons who have read and understood the entire operator's manual should operate this equipment.

This equipment is not intended for use by or around children.



It is the owner/operator's responsibility to comply with all applicable federal, state, and local laws, rules, and regulations regarding the ownership, operation, and transporting your equipment. Operators

should become thoroughly familiar with and comply with these applicable laws for operating and transporting equipment.



WARNING! Clean sawdust from all guards, vents, control boxes, or any area where sawdust may gather **after every 8-hour shift**. Failure to do so may result in fire, causing death or serious injury.



Keep Work Area Clean



WARNING! Maintain a clean and clear path for all necessary movement around the equipment and lumber stacks.

NOTICE Always properly dispose of all sawing by-products, including sawdust and wood debris, coolant, oil, fuel, oil filters, and fuel filters.

If replacing a component which has a safety decal affixed to it, make sure the new component also has the safety decal affixed.

Inspect all safety decals to ensure they are clean and readable. Replace all damaged safety decals to prevent personal injury or damage to the equipment. Contact your local distributor, or call your Customer Service Representative to order more decals.

Wear Safety Clothing (Personal Protection Equipment)



WARNING! Wear eye, ear, and foot protection when operating or servicing the equipment.

Secure all loose clothing, hair, and jewelry before operating the equipment.



Always use guards



WARNING! Do not operate this machine with any guard removed.

2.3 Electrical Lockout Procedures

RULES FOR USING LOCKOUT PROCEDURE

The sawmill shall be locked out to protect against accidental or inadvertent operation when such operation could cause injury to personnel. Do not attempt to operate any switch or valve bearing a lock.

LOCKOUT PROCEDURES MUST BE USED DURING:

- | | |
|------------------------------|----------------------------------------------------------------------|
| Changing or adjusting blades | Electrical maintenance |
| Unjamming operations | Retrieval of tools/parts from work area |
| Cleaning | Activities where guards or electrical panel guard is open or removed |
| Mechanical repair | |

MAINTENANCE HAZARDS INCLUDE:

Blade contact	Missiles (thrown blades/wood chips)
Pinch points	Electrical
Kickbacks	

FAILURE TO LOCKOUT MAY RESULT IN:

Cut	Serious injury and death
Crush	Amputation
Blindness	Burn
Puncture	Shock
Electrocution	

TO CONTROL MAINTENANCE DANGERS:

- Lockout procedures must be followed (see OSHA regulation 1910.147).
- Never rely on machine stop control for maintenance safety (emergency stops, on/off buttons, interlocks).
- Do not reach into moving blades or feed systems. Allow all coasting parts to come to a complete stop.
- Electrical power supply and air supply must both be locked out.
- Where established lockout procedures cannot be used (electrical troubleshooting or mechanical dynamic troubleshooting), alternative effective protective techniques shall be employed which may require special skills and planning.
- Always follow safe operations practices in the workplace.

SAWMILL LOCKOUT PROCEDURE

Lockout procedures per OSHA regulation 1910.147, appendix A:

GENERAL

The following simple lockout procedure is provided to assist owner/operators in developing their procedures so they meet the requirements of OSHA regulation 1910.147. When the energy isolating devices are not lockable, tagout may be used, provided the owner/operator complies with the provisions of the standard which require additional training and more rigorous periodic inspections. When tagout is used and the energy isolating devices are lockable, the owner/operator must provide full operator protection (see OSHA regulation 1910.147, paragraph (c)(3)) and additional training and more rigorous periodic inspections are required. For more complex systems, more comprehensive procedures may need to be developed, documented, and utilized.

PURPOSE

This procedure establishes the minimum requirements for the lockout of energy isolating devices whenever maintenance or servicing is done on machines or equipment. It shall be used to ensure that the machine or equipment is stopped, isolated from all potentially hazardous energy sources and locked out before personnel perform any servicing or maintenance where the unexpected energization or start-up of the machine or equipment or release of stored energy could cause injury.

COMPLIANCE WITH THIS PROGRAM

All personnel are required to comply with the restrictions and limitations imposed upon them during the use of lockout. The authorized personnel are required to perform the lockout in accordance with this procedure. All operators, upon observing a machine or piece of equipment which is locked out to perform servicing or maintenance shall not attempt to start, energize, or use that machine or equipment.

SEQUENCE OF LOCKOUT

1. Notify all affected personnel that servicing or maintenance is required on a machine or equipment and that the machine or equipment must be shut down and locked out to perform the servicing or maintenance.
2. The authorized employee shall refer to the company procedure to identify the type and magnitude of the energy that the machine or equipment utilizes, shall understand the hazards of the energy, and shall know the methods to control the energy.

3. If the machine or equipment is operating, shut it down by the normal stopping procedure (depress the stop button, open switch, close valve, etc.).
4. De-activate the energy isolating device(s) so that the machine or equipment is isolated from the energy source(s).
5. Lock out the energy isolating device(s) with assigned individual lock(s).
6. Stored or residual energy (such as that in capacitors, springs, elevated machine members, rotating fly-wheels, hydraulic systems, and air, gas, steam, or water pressure, etc.) must be dissipated or restrained by methods such as grounding, repositioning, blocking, bleeding down, etc.
7. Ensure that the equipment is disconnected from the energy source(s) by first checking that no personnel are exposed, then verify the isolation of the equipment by operating the push button or other normal operating control(s) or by testing to make certain the equipment will not operate.



CAUTION! Return operating control(s) to neutral or "off" position after verifying the isolation of the equipment.

8. The machine or equipment is now locked out.

RESTORING EQUIPMENT TO SERVICE

When the servicing or maintenance is completed and the machine or equipment is ready to return to normal operating condition, the following steps shall be taken.

1. Check the machine or equipment and the immediate area around the machine to ensure that nonessential items have been removed and that the machine or equipment components are operationally intact.
2. Check the work area to ensure that all personnel have been safely positioned or removed from the area.
3. Verify that the controls are in neutral.
4. Remove the lockout devices and re-energize the machine or equipment.

NOTE: The removal of some forms of blocking may require re-energization of the machine before safe removal.

5. Notify affected personnel that the servicing or maintenance is completed and the machine or equipment is ready for use.

PROCEDURE INVOLVING MORE THAN ONE PERSON

In the preceding steps, if more than one individual is required to lock out the sawmill, **each shall place his own personal lock on the energy isolating devices.**

2.4

SECTION 3 OPERATION

3.1 Site Preparation



WARNING! Have a certified electrician install the power to your machine. Failure to do so may result in death or serious injury.

Be sure the power supply cables are not a trip hazard.

Do not use a dust collection with recycled materials due to possible metal in the materials.

Do not operate this machine with any guard removed.



CAUTION! Improper voltage will cause damage to the motor and electronic components. Have a qualified electrician install the power supply to begin using your equipment.

NOTICE The power supply must meet the motor specifications concerning wire size, fused disconnect, and voltage, which are provided in the motor's manual. The electrical installation must also meet local codes.

NOTICE Ensure the blade spins in the proper direction. If not, have the electrician change the motor rotation.

NOTICE When using dust collection **with new materials only**, ensure an air flow of 600 cfm or better is available.

3.2 Onsite setup/assembly



WARNING! Maintain a clean and clear path for all necessary movement around the equipment and stacking areas.

Do not allow non-essential personnel (especially children) in the area of the equipment. Items may be ejected from waste chute.

Do not use in areas of low lighting, high moisture, or extreme temperatures.

Set up the equipment on level ground.

Outfeed Panel Assembly

1. Use a 3/16 hex key to unfasten the four 5/16 x 3/4 button head screws located in the threaded holes in the table. See Fig. 3-1.
2. Place the outfeed table in the orientation as shown in Fig. 3-1.

3. Tighten the screws.

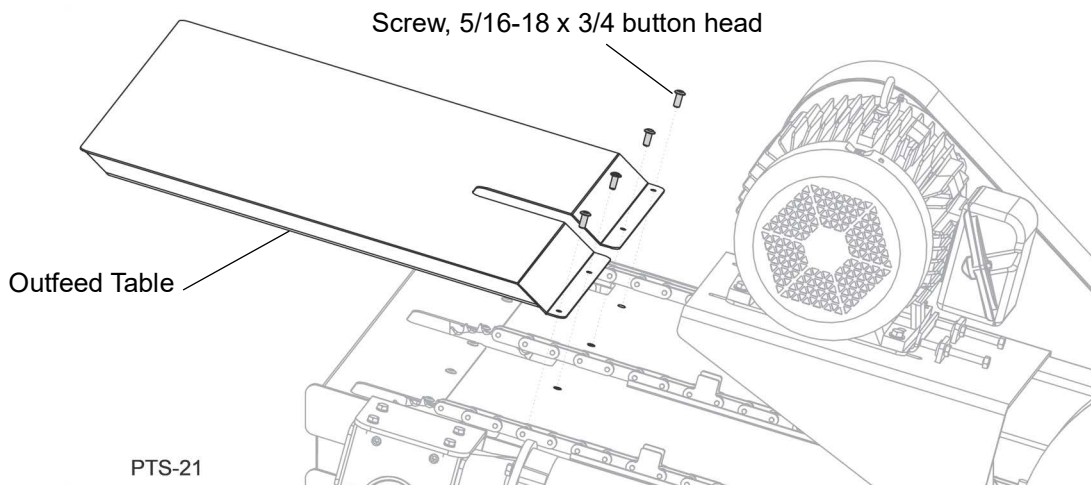

FIG. 3-1

Assemble the Board Stop Assembly

1. Remove the nuts from the six carriage bolts attached to the Board Stop Assembly.
2. Align the Board Stop Assembly as shown in Fig. 3-2.
3. Tighten the nuts.

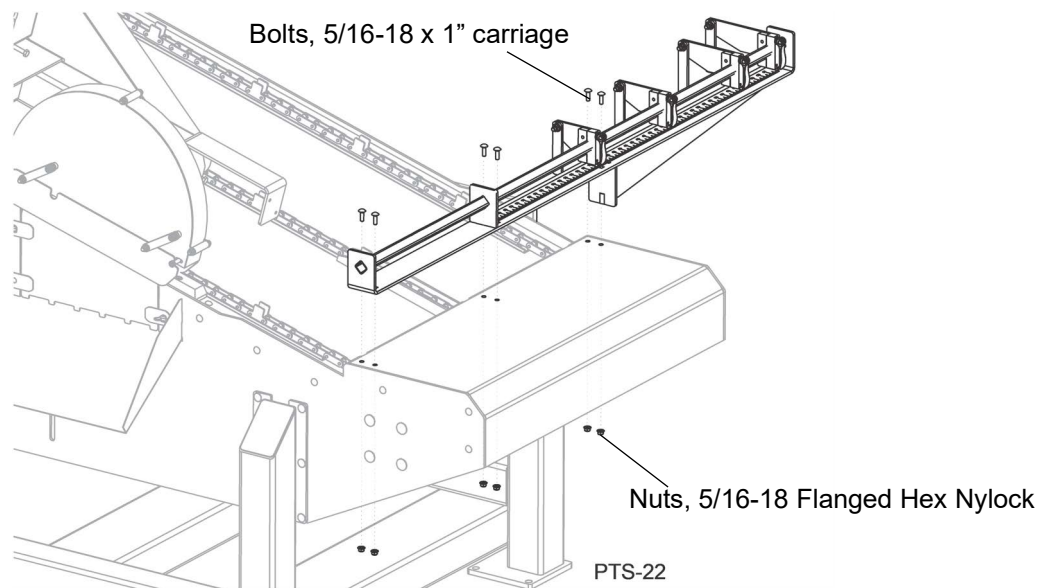

FIG. 3-2

3.3 Controls

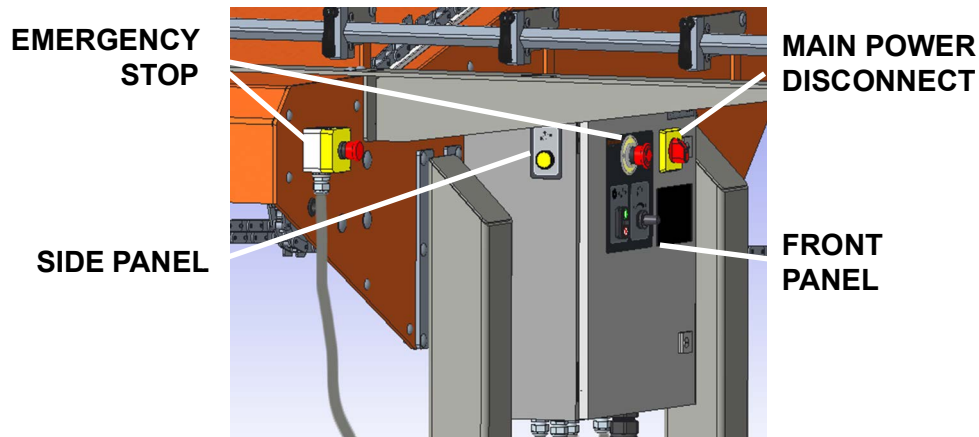

FIG. 3-3

EMERGENCY STOP - disconnects all external power to the machine. See Fig. 3-4.

CONVEYOR SPEED - sets board feed speed. See Fig. 3-4.

BLADE AND CONVEYOR - turns blade and conveyor on at the same time. See Fig. 3-4.

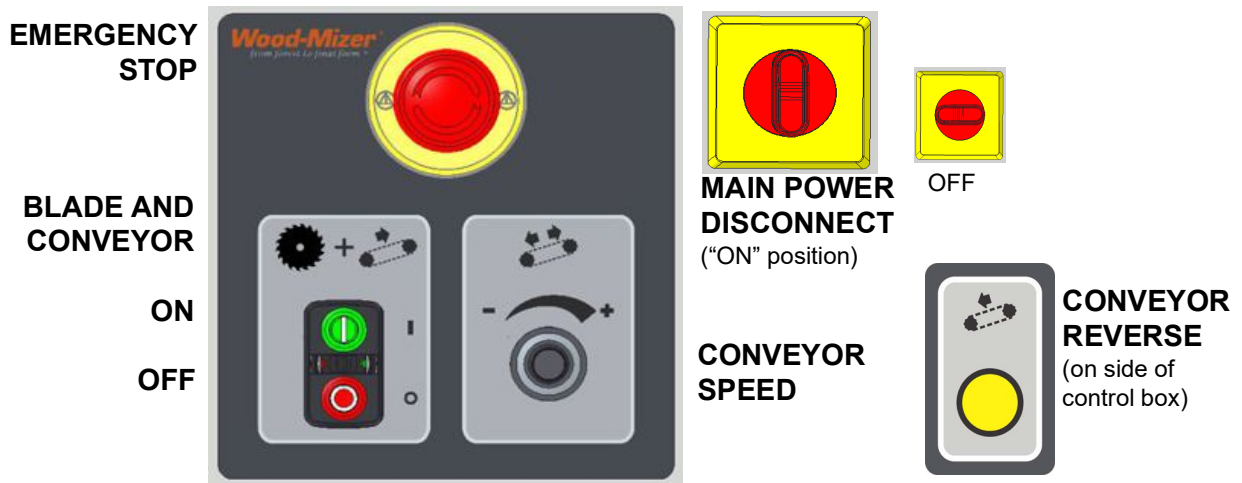

FIG. 3-4

3.4 Operation

WARNING! Keep hands 12" away from the blades. Failure to do so may result in death or serious injury.

Inspect the machine for wear, damage, and proper maintenance before each use.

Check the blade before operation for any wear or damage. Replace blade if wear or damage noticed.



Do not run the machine with the control panel open.

1. Set the board length(s).
 - a. Set the board stop(s) at the desired position(s).

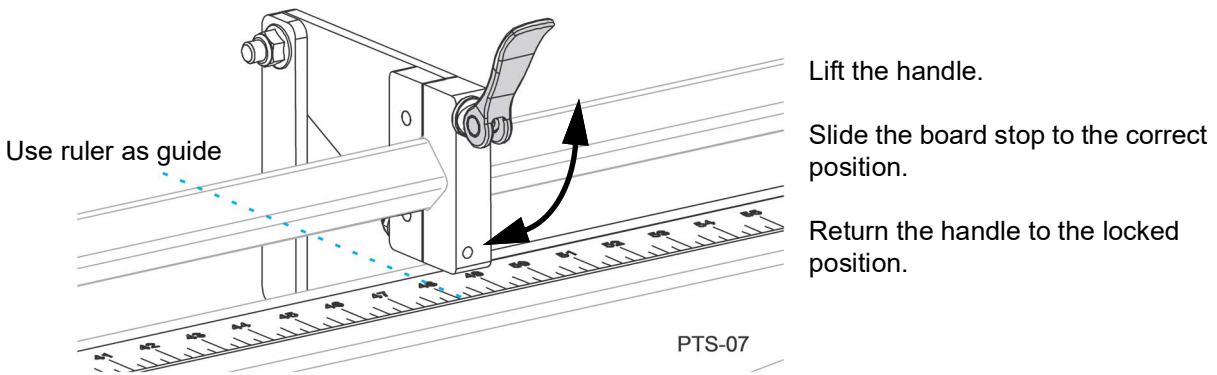

FIG. 3-5

- b. Flip the board stop plate up when a longer cut length is needed. See Fig. 3-6.

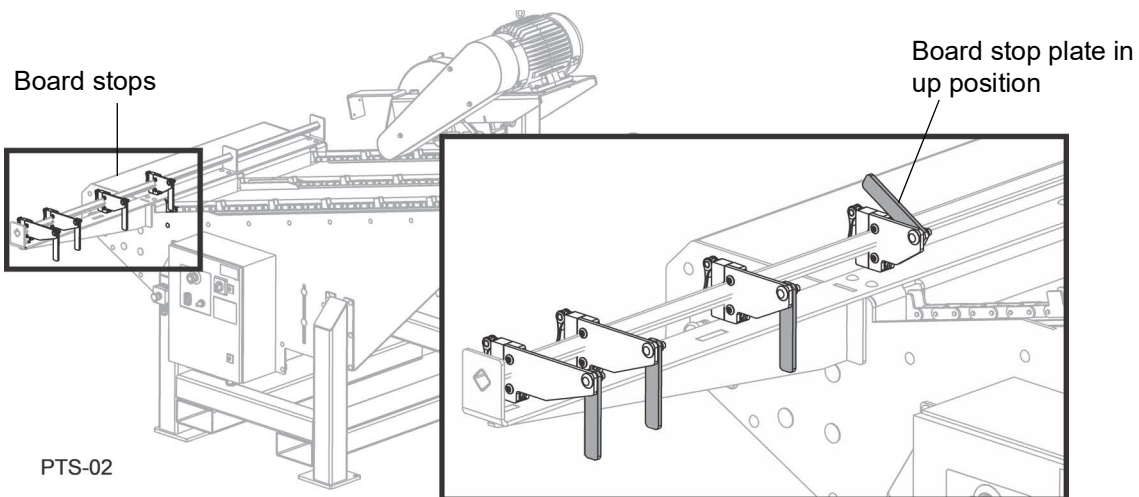

FIG. 3-6

2. Turn on the main power disconnect. See Fig. 3-4.
3. Press the Blade and Conveyor **ON** button. See Fig. 3-4.
4. Set the conveyor speed. See Fig. 3-4.
5. Set the board against the stop.

6. Set the board flat against the table until the conveyor chain dogs catch the board. See Fig. 3-7.

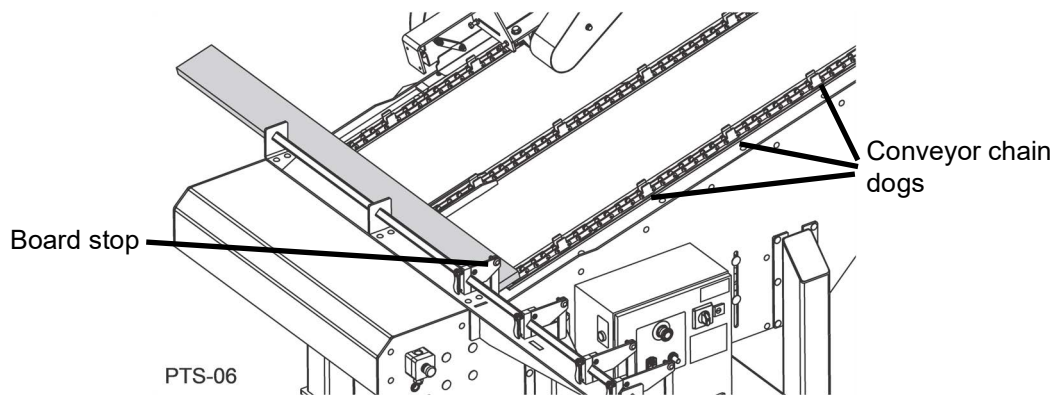

FIG. 3-7

7. Release the board.



CAUTION! Long boards could impact operator while moving up conveyor. Stay clear of moving boards.

8. Repeat steps 5 through 7 until finished.

NOTE: If you need to reverse the conveyor during operation, press and hold the conveyor reverse button on the side of the control panel.

9. Press the Blade and Conveyor **OFF** button. See Fig. 3-4.
10. Turn on the main power disconnect. See Fig. 3-4.

SECTION 4 MAINTENANCE



WARNING! Lock out power supply before performing any maintenance. See Electrical Lockout Procedures (OSHA regulation 1910.147, appendix A, reprinted in Section 2.3 Electrical Lockout Procedures).

Ensure all electrical installation, service, and/or maintenance is performed by a qualified electrician.

Ensure your unit is on a level surface and secure from movement.



WARNING! Clean sawdust from all guards, vents, control boxes, or any area where sawdust may gather **after every 8-hour shift**. Failure to do so may result in fire, causing death or serious injury.



Clean area after every 8-hour shift

Dispose of sawdust properly.

Metal particles not properly removed from used boards may be hot causing sawdust to slowly smolder and possibly ignite.

4.1 Lubrication

Lubricate all bearings after 3 months of operation.

Use a lithium based NLGI #2 grease for lubricating the **7 bearings** (5 flange at the chain drive shafts and 2 pillow block at the blade shaft) on this machine. See Fig. 4-1.

Grease should be added under low pressure with the shaft slowly turning to distribute the grease evenly.



CAUTION! Do not overfill the bearings. Overfilling will cause the bearing to overheat and will damage the seals.

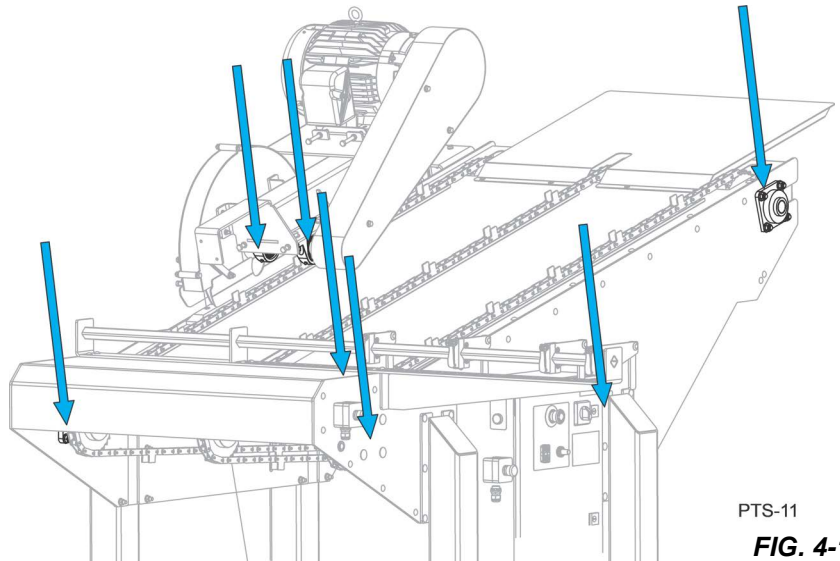

PTS-11

FIG. 4-1

4.2 Blade change

1. Remove the three nuts holding the blade guard cover. See Fig. 4-2.
2. Remove the lower access plate by removing the wing nuts. See Fig. 4-2.

3. Remove the arbor nut (**left hand thread**) and blade collar. See Fig. 4-2.

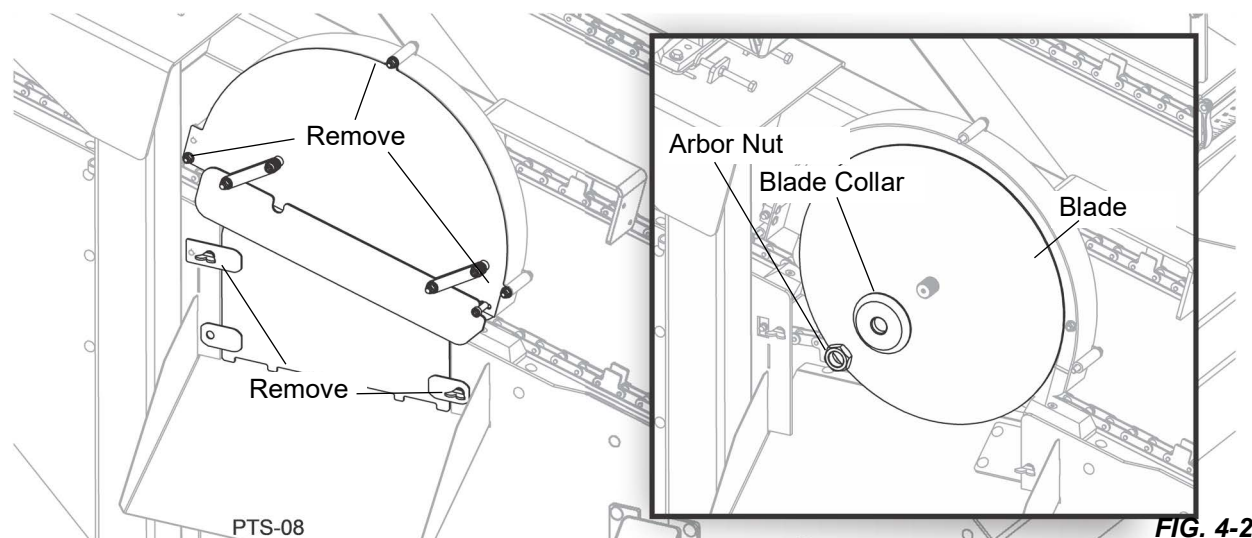

NOTE: The blade arbor has flats located between the bearing and blade guard where a 1-1/16" open end wrench can be used to hold it while removing the nut.

4. Place new blade on arbor.

NOTE: Ensure teeth are facing down on the leading edge.

5. Replace the collar in the same orientation as it came off.
6. Tighten the arbor nut (left hand thread) to 150 ft/lbs (+/- 5).
7. Replace all guards.



WARNING! Do not operate this machine with any guard removed.

4.3 Drive belt

Over time, the drive belt will stretch and need re-tightening. Note that the tension values are different between new belts and used belts.

Check the drive belt for wear every 8 hours of operation; replace as necessary.

REPLACE THE BELT

1. Ensure the machine has been electrically locked out.
2. Remove the three bolts and washers (split and flat) holding the belt guard in place.

3. Check the belt for wear, damage, and proper tension; replace or adjust as necessary.
4. Loosen (do not remove) the four motor mount bolts. See Fig. 4-3.
5. Decrease belt tension by loosening the adjustment bolts. (Loosen the jam nuts as necessary.) See Fig. 4-3.

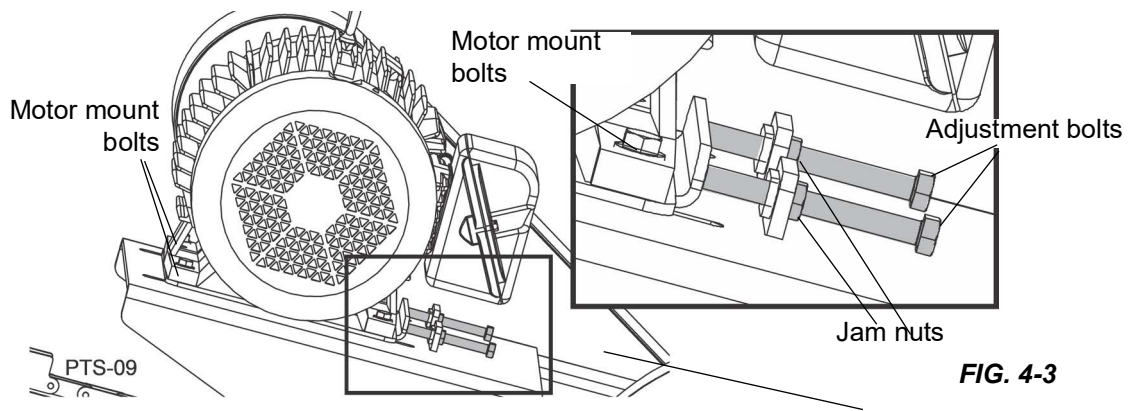

FIG. 4-3

6. Remove and replace the belt.
7. Check the belt tension with the Tension Tester (part number 016309) supplied with your Wood-Mizer.
 - a. Zero out the pounds indicator by sliding the small "O" ring against the yellow flange.
 - b. Set the deflection indicator to the deflection depth.

8. Place the gauge on the belt at the midpoint between the two pulleys.

- a. Press down on the rubber boot while the bottom of the gauge is against the belt.

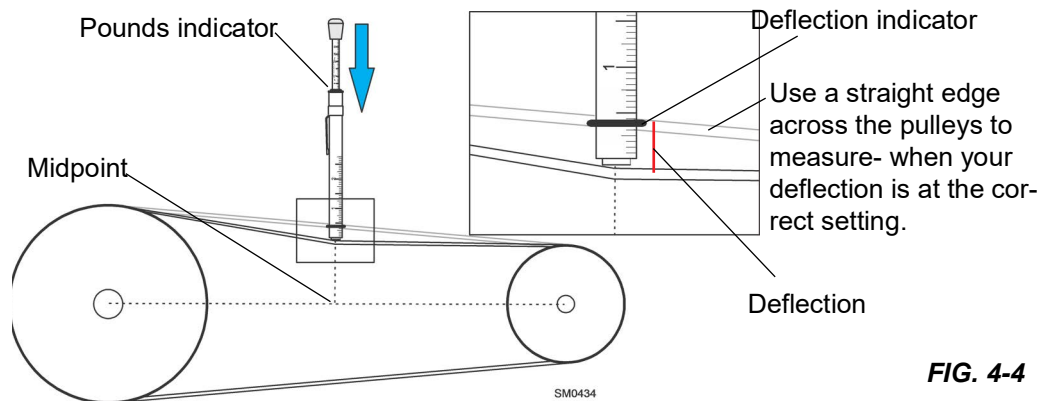

FIG. 4-4

9. If the belt tension is less than 5 lbs with 0.43" (~7/16") of deflection, tighten the belt as described below:

- a. Turn the belt tension adjustment bolts clockwise to tighten the belt, counterclockwise to loosen the belt.
- b. Tighten the adjustment bolt jam nuts when the proper belt tension is achieved. See Fig. 4-3.



CAUTION! Do not overtighten the belt. Damage to the equipment will occur.

10. Tighten the motor mount bolts. See Fig. 4-3.
11. Replace the belt guards

TIGHTEN THE BELT

1. Ensure the machine has been electrically locked out.
2. Remove the three bolts and washers (split and flat) holding the belt guard in place.
3. Loosen (do not remove) the four motor mount bolts. See Fig. 4-3.
4. Decrease belt tension by loosening the adjustment bolts. (Loosen the jam nuts as necessary.) See Fig. 4-3.
5. Check the belt tension with the Tension Tester (part number 016309) supplied with your Wood-Mizer.
 - a. Zero out the pounds indicator by sliding the small "O" ring against the yellow flange.
 - b. Set the deflection indicator to the deflection depth.

6. Place the gauge on the belt at the midpoint between the two pulleys.

- a. Press down on the rubber boot while the bottom of the gauge is against the belt.

7. If the belt tension is less than 4 lbs with 0.43" (~7/16") of deflection, tighten the belt as described below:

- a. Turn the belt tension adjustment bolts clockwise to tighten the belt, counterclockwise to loosen the belt.

- b. Tighten the adjustment bolt jam nuts when the proper belt tension is achieved. See Fig. 4-3.

8. Tighten the motor mount bolts. See Fig. 4-3.

9. Replace the belt guards.

4.4 Chain Maintenance

Lubricate the chain sprocket bearings every 200 hours of operation with one to two pumps of lithium-based grease such as Shell Alvania No. 3. Do not overgrease.

The chain needs to be adjusted if the chain slack exceeds 1/2" (12.7mm).

1. Ensure the machine has been electrically locked out.
2. Loosen the 4 (2 on each side) carriage bolt nuts holding the chain idle shaft.

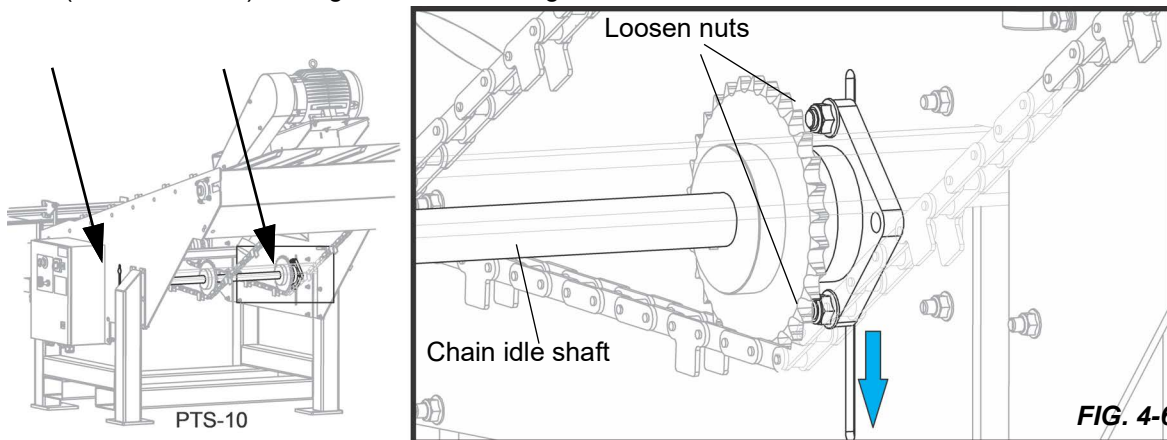

3. Move entire shaft down to take up the slack.



CAUTION! Do not overtighten the chain. Equipment damage may occur.

4. Tighten all carriage bolt nuts.

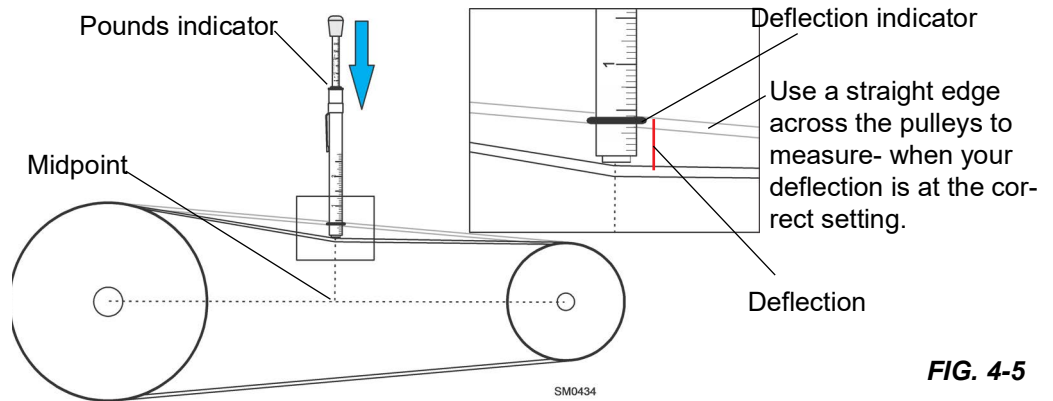

SECTION 5 REPLACEMENT PARTS

5.1 How To Use The Parts List

- Use the table of contents to locate the assembly that contains the part you need.
- Go to the appropriate section and locate the part in the illustration.
- Use the number pointing to the part to locate the correct part number and description in the table.
- Parts shown indented under another part are included with that part.

To Order Parts

- From the continental US, call **1-800-525-8100** to order parts. Have your customer number, vehicle identification number, and part numbers ready when you call.
- From other international locations, contact the Wood-Mizer distributor in your area for parts.

5.2 Sample Assembly



REF	PART #	DESCRIPTION	COMMENTS	QTY.
	012345	SAMPLE ASSEMBLY, COMPLETE	INCLUDES ITEMS 1-6	1
1	F02222-22	Sample Part		1
2	F03333-33	Sample Part		2
	098765	Sample Subassembly	Includes items 3-6	1
3	S04444-44	Subassembly Sample Part		1
4	K55555	Subassembly Sample Part		1
	054321	Sample Sub-Subassembly	Includes items 5-6	2
5	022222	Sub-Subassembly Sample Part		1
6	F10234-56	Sub-Subassembly Sample Part		1

The Sample Assembly, Complete, part number 02345 (top level assembly) includes two parts (F0222-22 and F0333-33) and the 098765 subassembly.

Subassembly 098765 contains two parts(S04444-44 and K55555) and two copies of sub-subassembly 054321.

Each sub-subassembly 054321 contains two parts (022222 and F10234-56).

5.3 Torque Values

Grade		Units	SAE 5	SAE 8
Grade Mark				
Bolt Dia.	Threads. Per In.	Units	SAE 5	SAE 8
6	32	in-lbs (Nm)	20 (2.3)	-
8	32	in-lbs (Nm)	24 (2.7)	30 (3.4)
10	24	in-lbs (Nm)	35 (4.0)	45 (5.1)
10	32	in-lbs (Nm)	40 (4.5)	50 (5.7)
12	24	in-lbs (Nm)	50 (5.7)	65 (7.3)
1/4	20	in-lbs (Nm)	95 (10.7)	125 (14.1)
1/4	28	in-lbs (Nm)	95 (10.7)	150 (17.0)
5/16	18	ft-lbs (Nm)	17 (22.6)	23 (31.2)
5/16	24	ft-lbs (Nm)	20 (27.1)	25 (33.8)
3/8	16	ft-lbs (Nm)	30 (40.7)	40 (54.2)
3/8	24	ft-lbs (Nm)	35 (47.5)	45 (61.0)
7/16	14	ft-lbs (Nm)	50 (67.8)	65 (88.1)
7/16	20	ft-lbs (Nm)	55 (74.6)	70 (94.9)
1/2	13	ft-lbs (Nm)	75 (101.7)	100 (135.6)
1/2	20	ft-lbs (Nm)	85 (115.3)	110 (149.2)
9/16	12	ft-lbs (Nm)	105 (142.4)	135 (183.1)
9/16	18	ft-lbs (Nm)	115 (155.9)	150 (203.4)
5/8	11	ft-lbs (Nm)	150 (203.4)	195 (264.4)
5/8	18	ft-lbs (Nm)	160 (217.0)	210 (284.8)
3/4	10	ft-lbs (Nm)	170 (230.5)	220 (298.3)
3/4	16	ft-lbs (Nm)	175 (237.3)	225 (305.1)
7/8	9	ft-lbs (Nm)	302 (409.5)	473 (640.9)
7/8	14	ft-lbs (Nm)	300 (406.8)	400 (542.4)
1	8	ft-lbs (Nm)	466 (631.8)	714 (967.4)

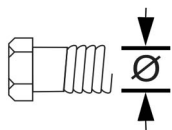

Metric Bolt Head Identification



8.8
Metric Grade 8.8



10.9
Metric Grade 10.9

COARSE THREAD					FINE THREAD				Wrench Size	
Diameter & Thread Pitch	Metric 8.8		Metric 10.9		Diameter & Thread Pitch	Metric 8.8		Metric 10.9		
	N-m	lbs-ft	N-m	lbs-ft		N-m	lbs-ft	N-m		lbs-ft
6 x 1.0	8	6	11	8					10 mm	
8 x 1.25	20	15	27	20	8 x 1.0	21	16	29	22	13 mm
10 x 1.5	39	29	54	40	10 x 1.25	41	30	57	42	16 mm
12 x 1.75	68	50	94	70	12 x 1.25	75	55	103	76	18 mm
14 x 2.0	109	80	151	111	14 x 1.5	118	87	163	120	21 mm
16 x 2.0	169	125	234	173	16 x 1.5	181	133	250	184	24 mm
18 x 2.5	234	172	323	239	18 x 1.5	263	194	363	268	27 mm
20 x 2.5	330	244	457	337	20 x 1.5	367	270	507	374	30 mm
22 x 2.5	451	332	623	460	22 x 1.5	495	365	684	505	34 mm
24 x 3.0	571	421	790	583	24 x 2.0	623	459	861	635	36 mm
30 x 3.0	1175	867	1626	1199	30 x 2.0	1258	928	1740	1283	46 mm

5.4 Torque (Part A)

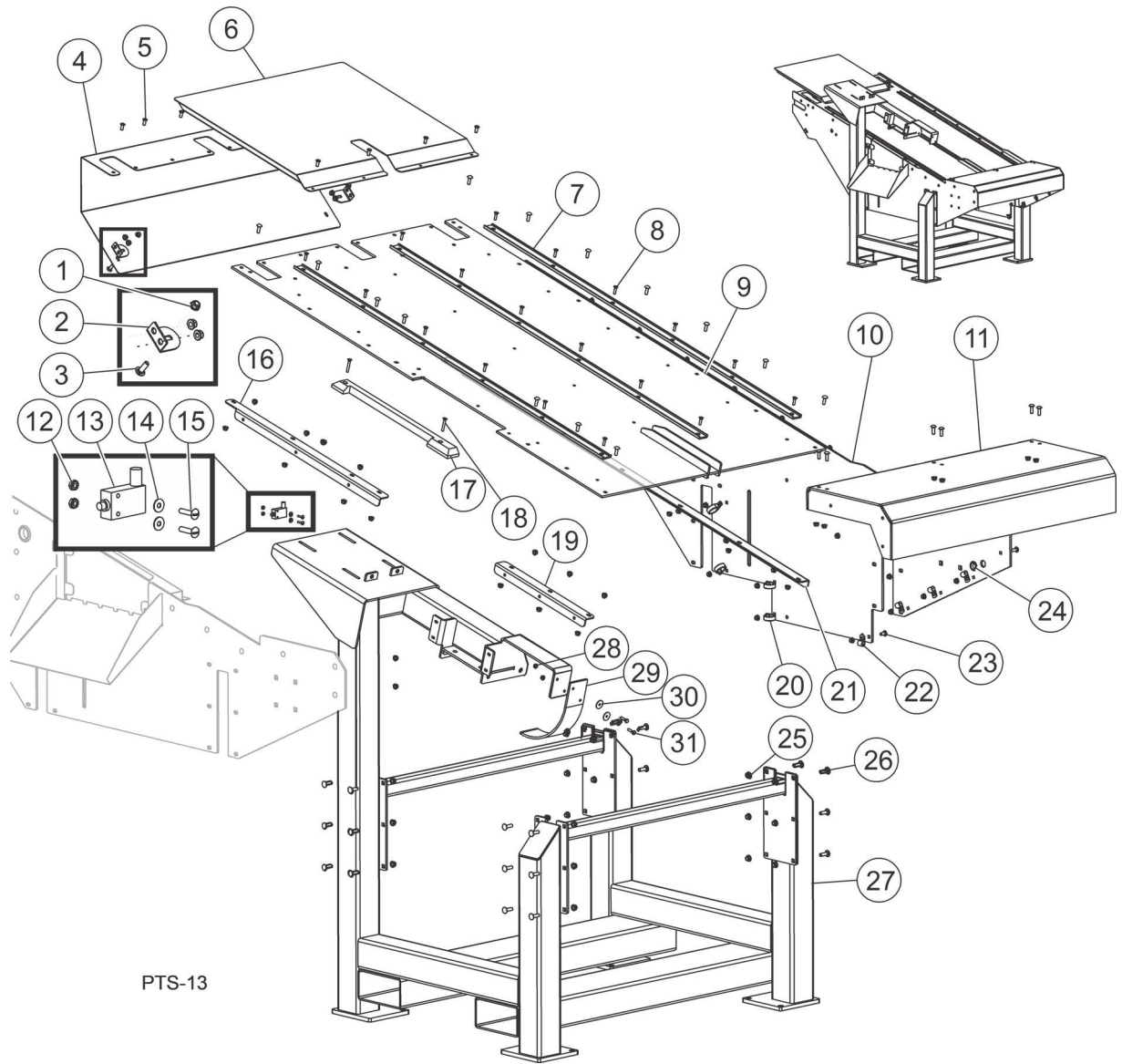

PTS-13

REF	PART #	DESCRIPTION	COMMENTS	QTY.
1	F05010-221	Nut, 5/16-18 Flanged Hex Nylock		40
2	119033	Bracket, PC200 Chain Guard		2
3	F05006-90	Bolt, 5/16-18x1 Carriage Gr5		32
4	119034	Guard, PC200 Chain		1
5	F05006-84	Screw, 5/16-18x3/4 BHSC SS		
6	119108	Weldment, PC200 Outfeed		1
7	130469	Channel, C2060 Chain Guide		3
8	F05005-70	Screw, 1/4-20x1 FHS		18
9	128040	Table Weldment, PC200, Main		1
10	119004	Plate, PC200 Right Table		1
11	128119	Table Weldment, PC200, Front		1
12	F05010-14	Nut, #10-24 Keps		2

REF	PART #	DESCRIPTION	COMMENTS	QTY.
13	121014	Safety Limit Switch, 1NO 1NC Plunger		2
14	F05011-18	Washer, #10 SAE Flat		2
15	F05001-33	Bolt, #10-24x7/8 S1 Round Head		2
16	128048	Angle, PC200 Table Support, Mid		1
17	119027	Plate, Blade Guide		1
18	F05005-193	Screw, 1/4-20x1 3/4 FHS BO		2
19	128047	Angle, PC200 Table Support, Short		1
20	038482	Clamp, 1-1/4 Carbon Steel Conduit		6
21	128041	Angle, PC200 Table Support, Long		1
22	P07584	Clamp, 1/2EMT Coated		4
23	F05006-86	Bolt, 5/16-18x3/4 Carriage		8
24	033475	Grommet, 5/8 ID 3/16 GW Rubber		1
25	F05010-222	Nut, 3/8-16 Flanged Hex Nylock		24
26	F05007-127	Bolt, 3/8-16x1 1/4 Carriage Gr5		24
27	119007	Weldment, PC200 Frame		1
28	F05010-220	Nut, 1/4-20 Flanged Hex Nylock		2
29	119008	Flap, PC200 Holddown		1
30	F05011-12	Washer, 1/4 Fender		2
31	F05005-101	Bolt, 1/4-20x1 HH Gr5		2

5.5 Frame (Part B)

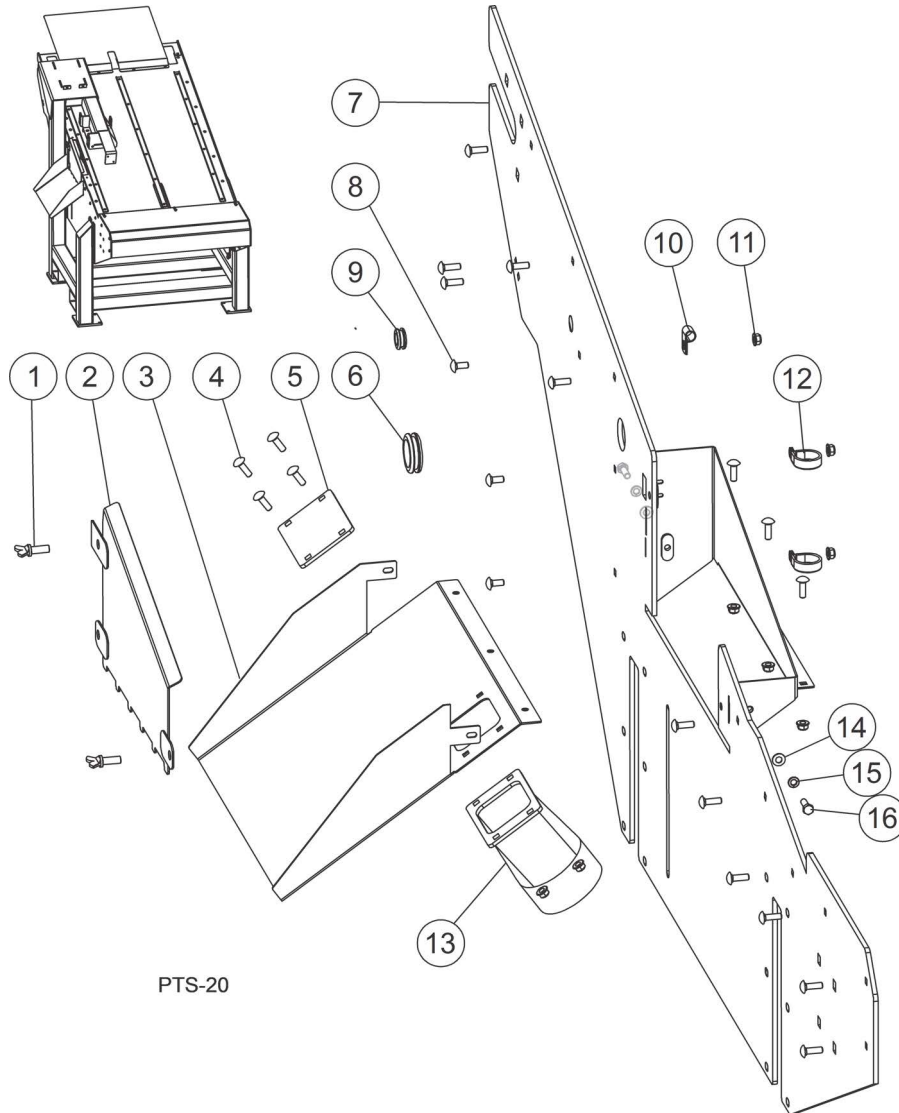

PTS-20

REF	PART #	DESCRIPTION	COMMENTS	QTY.
1	F05007-173	Bolt, 3/8-16x1 Wing		2
2	119028	Weldment, Lower Access Panel		1
3	119019	Plate, Trash Shoot Bottom		1
4	F05006-90	Bolt, 5/16-18x1 Carriage Gr5		10
5	128104	Plate, PC200 Sawdust Block Off		1
6	079512	Grommet, 1-3/4Hole x 1/4Panel Thk		1
7	128103	Weldment, PC200 Left Table		1
8	F05006-86	Bolt, 5/16-18x3/4 Carriage		3
9	033475	Grommet, 5/8 ID 3/16 GW Rubber		1
10	P07584	Clamp, 1/2EMT Coated		1
11	F05010-221	Nut, 5/16-18 Flanged Hex Nylock		13
12	038482	Clamp, 1-1/4 Carbon Steel Conduit		2
13	128101	Chute Weldment, Sawdust		1
14	F05011-17	Washer, 5/16 SAE Flat		2
15	F05011-13	Washer, 5/16 Split Lock		2
16	F05006-27	Bolt, 5/16-18x1 Gr5 HH		2

5.6 Blade Cover

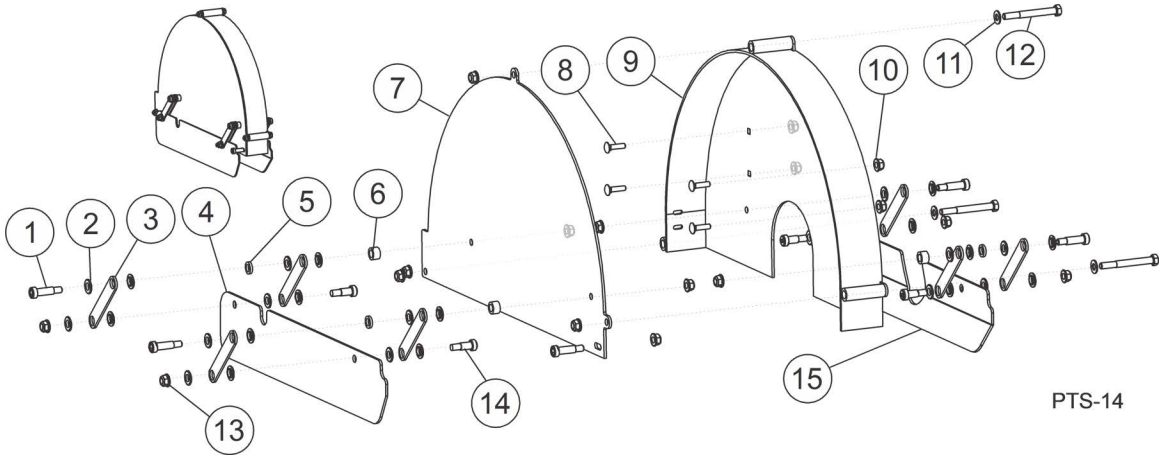

REF	PART #	DESCRIPTION	COMMENTS	QTY.
	119087	ASSEMBLY, 18" BLADE SAFETY CVR		
1	F05006-25	Bolt, 3/8x1 Shoulder 5/16-18 Thread		5
2	033454	Washer, 3/8 ID 3/4 OD Nylon Shoulder		24
3	128066	Link, PC200 Blade Guard		8
4	128069	Guard, PC200 Outer Blade		1
5	055323	Spacer, .39x.625x.39		4
6	003212	Spacer, .39x.63x.12		4
7	119093	Blade, PC200 Front Cover		1
8	F05005-34	Bolt, 1/4-20x1 Carriage		4
9	119112	Weldment, 18" Blade Safety Cvr		1
10	F05010-220	Nut, 1/4-20 Flanged Hex Nylock		4
11	F05011-17	Washer, 5/16 SAE Flat		6
12	F05006-62	Bolt, 5/16-18x3 HH Gr5		3
13	F05010-221	Nut, 5/16-18 Flanged Hex Nylock		9
14	F05007-79	Screw, 3/8x5/8 Socket Shoulder		1
15	128070	Guard, PC200 Inner Blade		1

5.7 Board Stop Assembly

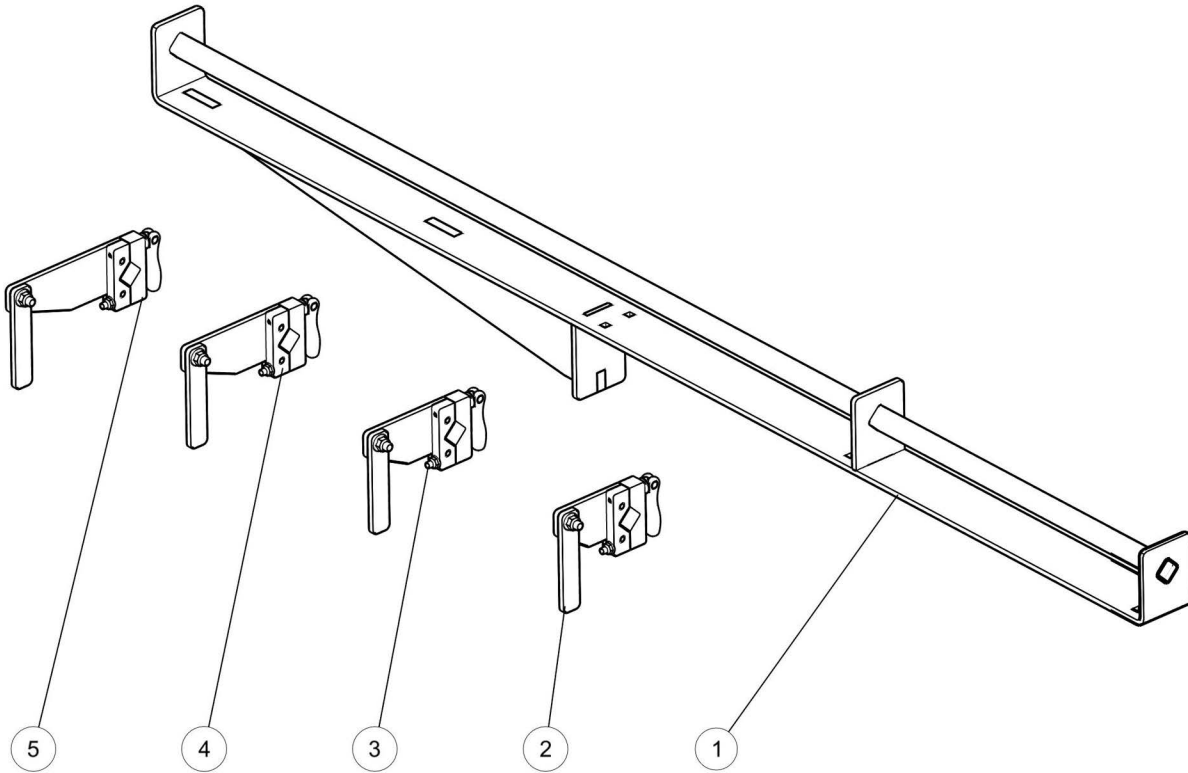

TD119044

REF	PART #	DESCRIPTION	COMMENTS	QTY.
	119044	ASSEMBLY, BOARD STOP		
1	119045	Wldmnt, PC200 Board Stop		1
2	133264	Assy, Stop PC200 4in	(See Section 5.8)	1
3	133265	Assy, Stop PC200 5in	(See Section 5.8)	1
4	133266	Assy, Stop PC200 6in	(See Section 5.8)	1
5	133267	Assy, Stop PC200 7in	(See Section 5.8)	1

5.8 Stop Assemblies

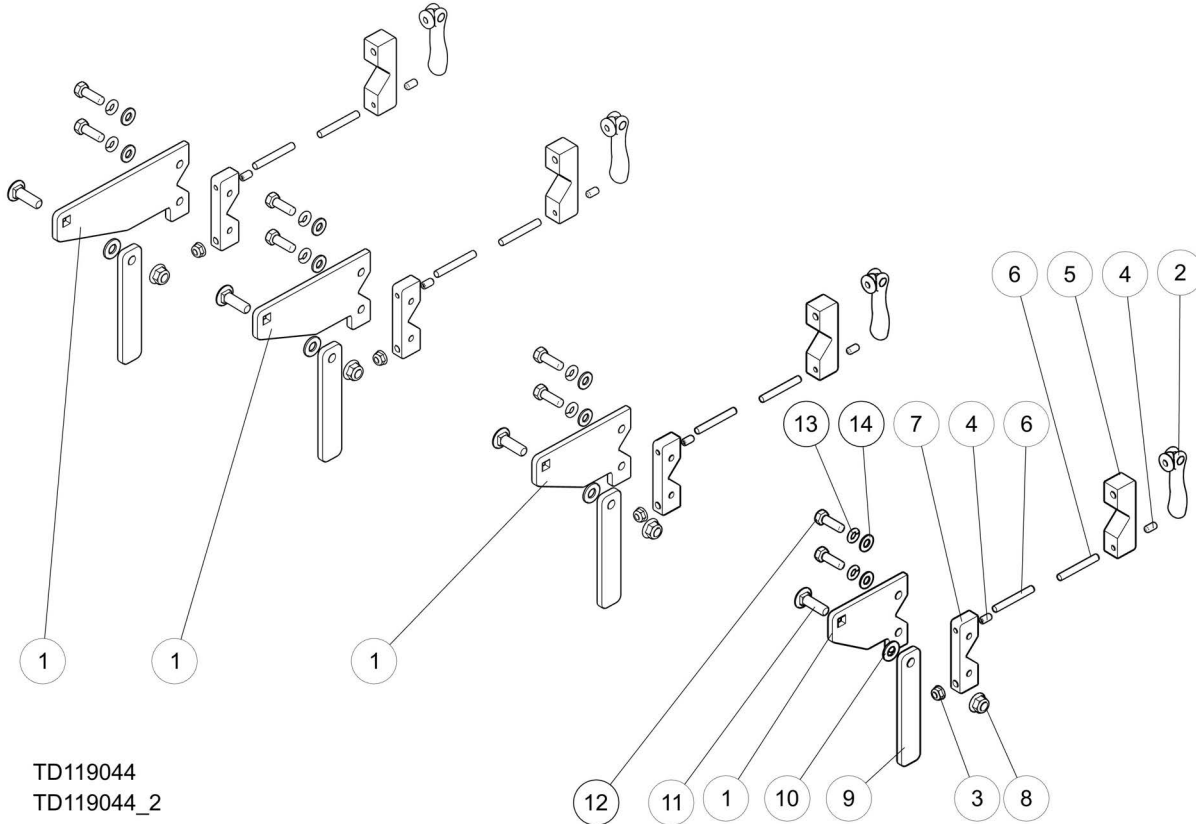

REF	PART #	DESCRIPTION	COMMENTS	QTY.
	133264	Assy, Stop PC200 4in		1
	133265	Assy, Stop PC200 5in		1
	133266	Assy, Stop PC200 6in		1
	133267	Assy, Stop PC200 7in		1
1	119053-4	Plate, Stop Clamp Pivot, 4 in		1
	119053-5	Plate, Stop Clamp Pivot, 5 in		1
	119053-6	Plate, Stop Clamp Pivot, 6 in		1
	119053-7	Plate, Stop Clamp Pivot, 7 in		1
	119056	Assy, Clamping Handle		1
2	119056-1	Handle, Clamping		1
3	F05010-220	Nut, 1/4-20 Flanged Hex Nylock		1
4	F05005-55	Screw, 1/4-20x1/2 SH Nyl Lock SS		2
5	119055	Bar, Stop Clamp		1
6	023638	Stud, Tensioner		2
7	119054	Bracket, Stop Clamp Base		1
8	F05010-222	Nut, 3/8-16 Flanged Hex Nylock		1
9	119057	Bar, 1x1/4x5 1/4 Board Stop		1
10	F05011-3	Washer, 3/8 Flat SAE		1
11	F05007-11	Bolt, 3/8-16x1 1/4 Carriage		1
12	F05006-27	Bolt, 5/16-18x1 Gr5 HH		2
13	F05011-13	Washer, 5/16 Split Lock		2
14	F05011-17	Washer, 5/16 SAE Flat		2

5.9 Chain Drive System

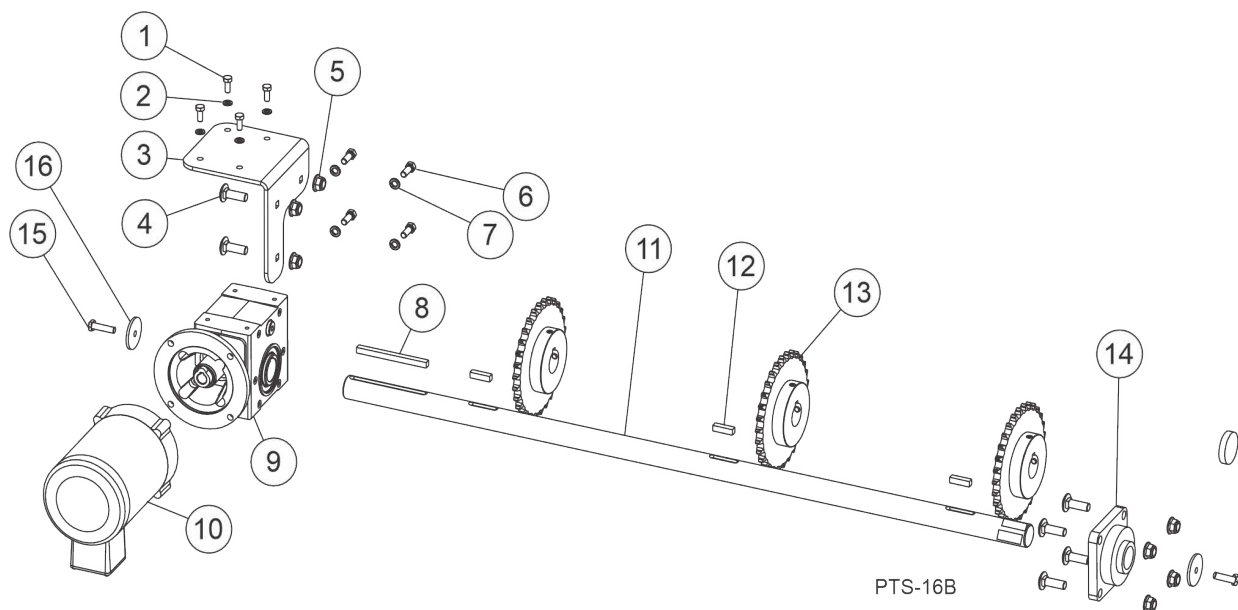

REF	PART #	DESCRIPTION	COMMENTS	QTY.
1	F05021-2	Bolt, M8-1.25x20 Class 8 HH		4
2	F05011-45	Washer, 8mm Split Lock, Zn		4
3	119041	Mount, Gear Box		1
4	F05008-150	Bolt, 1/2-13x1-1/2 Carriage		7
5	F05010-223	Nut, 1/2-13 Flanged Hex Nylock		7
	119035	ASSEMBLY, PC200 DRIVE SYSTEM		
6	F05007-87	Bolt, 3/8-16x1 HH Gr5		4
7	F05011-4	Washer, 3/8 Split Lock		4
8	128310	Key, 3/8x5/16x4-7/8		1
9	119039	Gearbox, 60:1 1-7/16 Hollow 56C		1
10	119040	Motor, 1/2HP 56C 3Ph 1725 RPM		1
11	119036	Shaft, PC200 Drive		1
12	014693	Key, 3/8x3/8x1 7/8		3
13	119037	Sprocket, 60B30x1 7/16		3
14	038667	Bearing, 1-7/16 Dia, 4-Bolt Flange		1
15	F05007-123	Bolt, 3/8-16x1 1/4 FT HH Gr5		2
16	028141	Washer, Gearbox Keeper		2

5.10 Idle Chain System

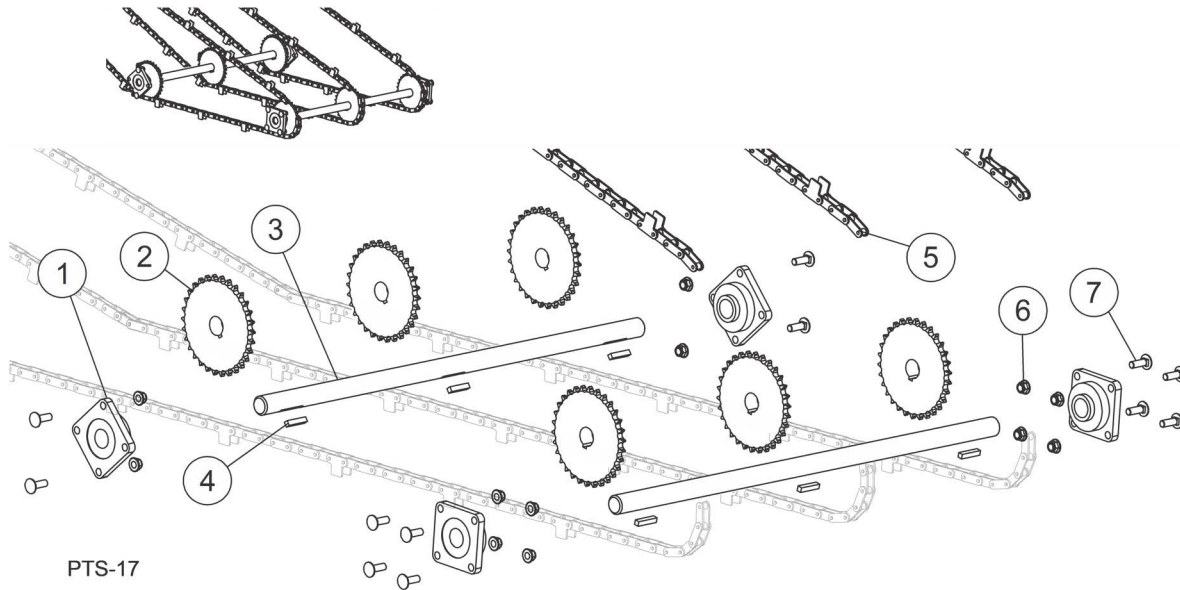

REF	PART #	DESCRIPTION	COMMENTS	QTY.
	119042	ASSEMBLY, DRIVEN SYSTEM		1
1	038667	Bearing, 1-7/16 Dia, 4-Bolt Flange		2
2	119037	Sprocket, 60B30x1 7/16		3
3	119043	Shaft, Ø1-7/16x48, 3/8 keyway		1
4	014693	Key, 3/8x3/8x1 7/8		3
5	119058	Assembly, C2060H 120 Link 12" Dogs		3
	064780	Link, C2060H Master		3
6	F05010-223	Nut, 1/2-13 Flanged Hex Nylock		16
7	F05008-150	Bolt, 1/2-13x1-1/2 Carriage		16

5.11 Motor Assembly

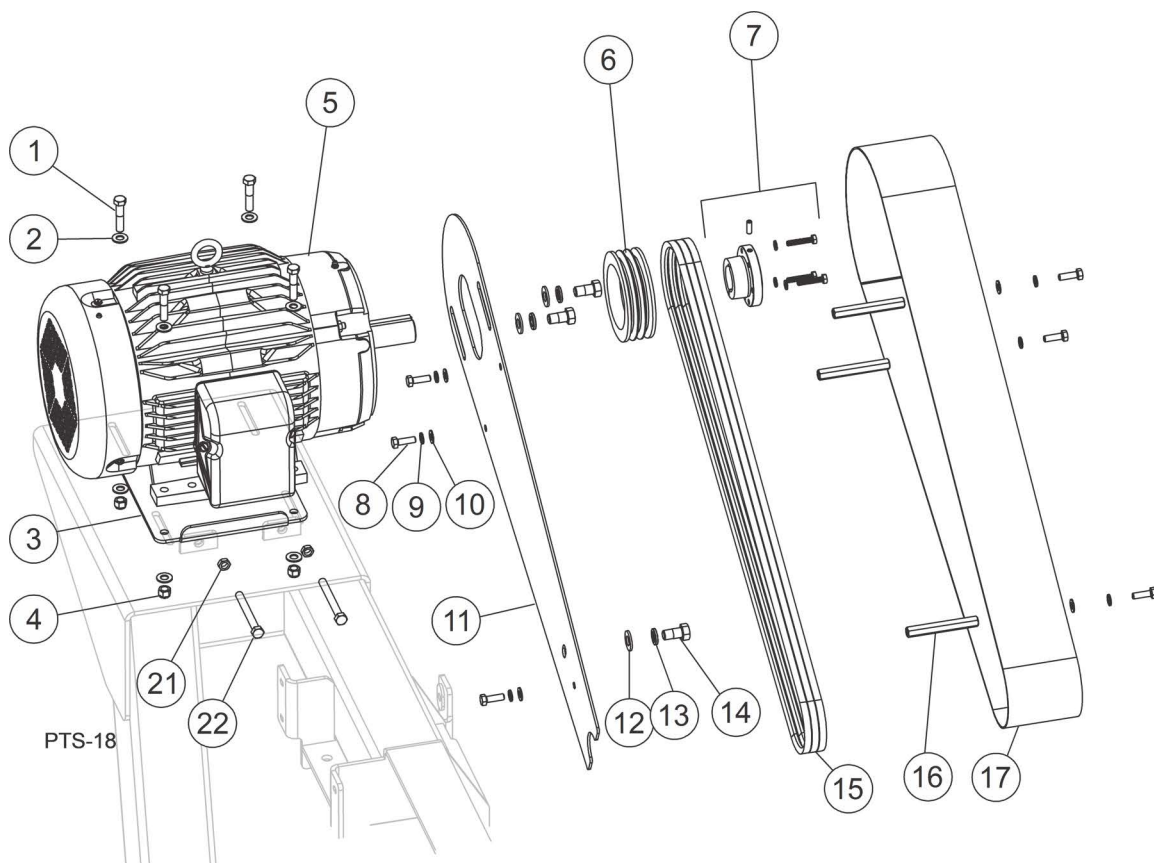

REF	PART #	DESCRIPTION	COMMENTS	QTY.
	130843	ASSEMBLY, PC200 MOTOR 10HP 1PH	Used with PC200A10	1
	119072	ASSEMBLY, PC200 MOTOR, 3PH, 230/460V	Used with PC200B10/C10/H10	1
1	F05007-119	Bolt, 3/8-16x1 3/4 HH Gr5		4
2	F05011-3	Washer, 3/8 Flat SAE		4
3	128121	Plate, PC200 Motor Adj.		1
4	F05010-222	Nut, 3/8-16 Flanged Hex Nylock		4
5	079949	Motor, 10HP 230V 1Ph 60Hz 1740RPM	PC200A10	1
	130076	Motor, Marathon 10HP 3P 230/460V1800RPM	PC200B10/C10/H10	1
6	119077	Sheave, 3/3Vx475 SDS		1
7	119076	Bushing, SDSx1-3/8		1
8	F05006-27	Bolt, 5/16-18 x 1 Gr 5 HH		3
9	F05011-13	Washer, 5/16 Split Lock		3
10	F05011-17	Washer, 5/16 SAE Flat		3
11	119095	Plate, PC200 Belt Cover Back		1
12	F05011-2	Washer, 1/2 SAE Flat		3
13	F05011-9	Washer, 1/2 Split Lock		3
14	F05008-71	Bolt, 1/2-13x1 HH FT		3
15	119097	Belt, 3Vx650		3
16	128126	Standoff, 3 13/16, 5/16-18		3
17	119098	Weldment, PC200 Belt Cover		1
18	F05007-1	Bolt, 3/8-16x3 FT HH		2
19	F05010-29	Nut, 3/8-16 Jam		2

5.12 CONTROL ASSEMBLY, PC200EA 240V 1PH

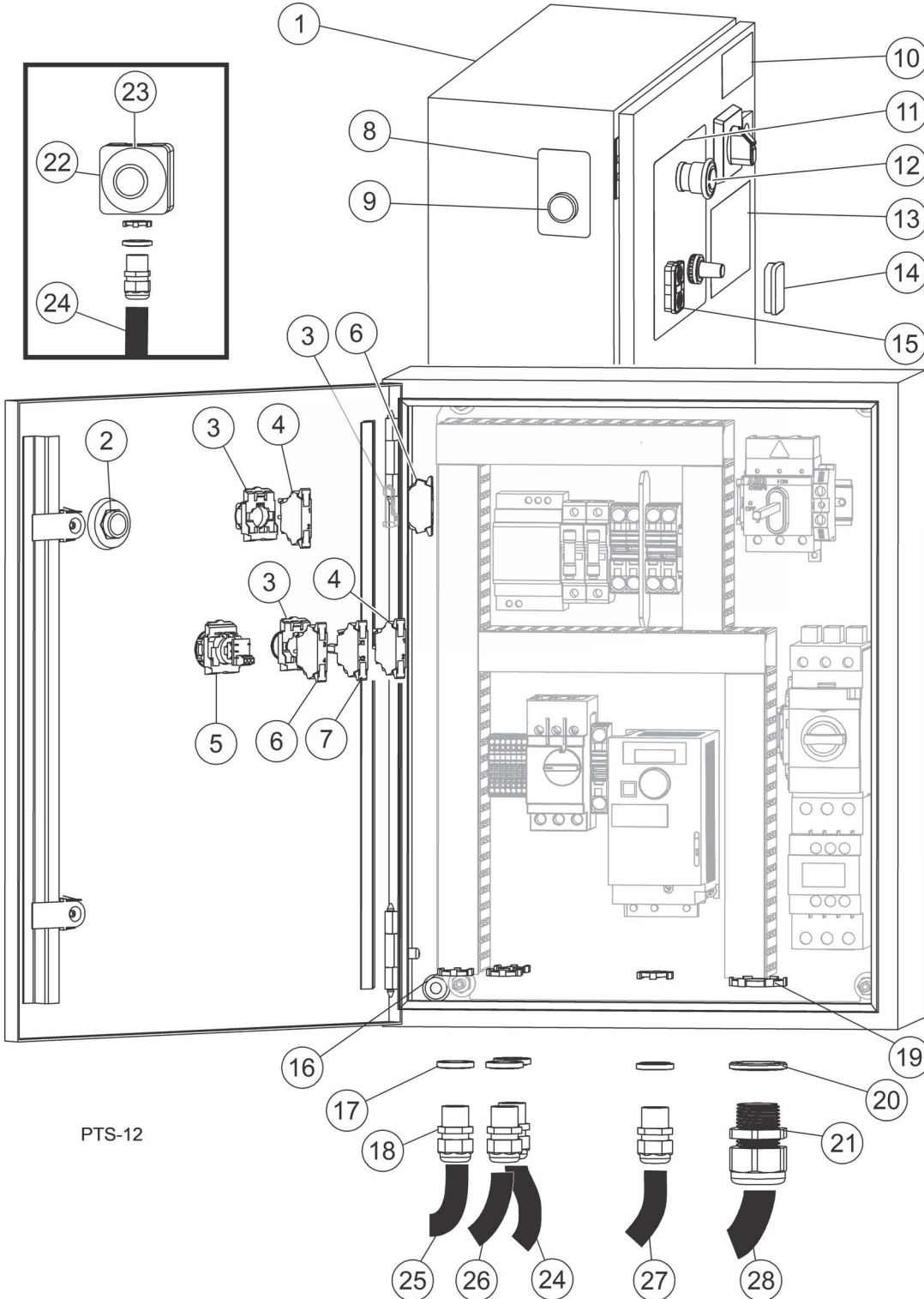

REF	PART #	DESCRIPTION	COMMENTS	QTY.
	121024	CONTROL ASSEMBLY, PC200EA 240V 1PH		
1	121004	Enclosure, PC200 Control		1
	050883-1	Handle, Disconnect RED/YEL 6mm Shaft		1
	068952	Collar, Mount 1NO ZB5		1
3	068951	Switch Collar, Mount ZB5		1
6	068920	Contact Block, NO ZB5		1

5 Replacement Parts
Control Assembly, PC200EA 240V 1Ph

REF	PART #	DESCRIPTION	COMMENTS	QTY.
	068950	Collar, Mount 1NC ZB5		2
3	068951	Switch Collar, Mount ZB5		1
4	068921	Contact Block, NC ZB5		1
5	068582	Potentiometer, 22mm 4.7k-Ohm		1
6	068920	Contact Block, NO ZB5		1
7	068910	Light Module, Green ZB5		1
8	068589	Decal, PC200 Reverse Switch		1
9	068902	Push Button Head, Flush Yellow ZB5		1
10	121024-NPLBL	Label, PC200EA Nameplate		1
11	068588	Decal, PC200 Operator Front		1
12	068940	Push-Button, Mshrm Mntnd Red TrnRI ZB5		1
13	068573	Decal, Arc Flash Warning 5Pk		1
14	052501	Boot, Clear Sealing ZB Sw		1
15	068909	Push-Button, Grn/Red Flush Illuminated		1
16	E20461	Nut, 1/2 NPT Connector Lock		5
17	E20460	Ring, 1/2 Sealing		5
18	051299	Connector, 1/2" NPT .17-.47		5
19	053735	Nut, 1" NPT Connector Lock Sealing		1
20	053734	Ring, 1" Sealing		1
21	069861	Connector, 1" NPT 0.59-1.00		1
	069861-1	Connector, 1" NPT 0.49-0.785 **USED WITH PC200C10 480V 3PH ONLY**		1
22	052999	E-Stop Box, 40mm Oper-10A NC		1
23	050992	Legend, E-Stop, Round Yellow		1
24	127309	Cable Assembly, PC200 Remote E-Stop		1
25	127307	Cable Assembly, PC200 Upper Blade Guard LS1		1
26	127308	Cable Assembly, PC200 Upper Blade Guard LS2		1
27	127304	Cable Assembly, PC200 Feed Motor		1
28	127310	Cable Assembly, PC200EA Blade Motor, 240V 1PH		1
	127301	Cable Assembly, PC200EB Blade Motor, 240V 3PH		1
	127305	Cable Assembly, PC200EC Blade Motor, 480V 3PH		1
		Insert Panel Assembly (See appropriate Electrical Information manual)		

5.13 CONTROL ASSEMBLY, PC200EB 240V 3PH

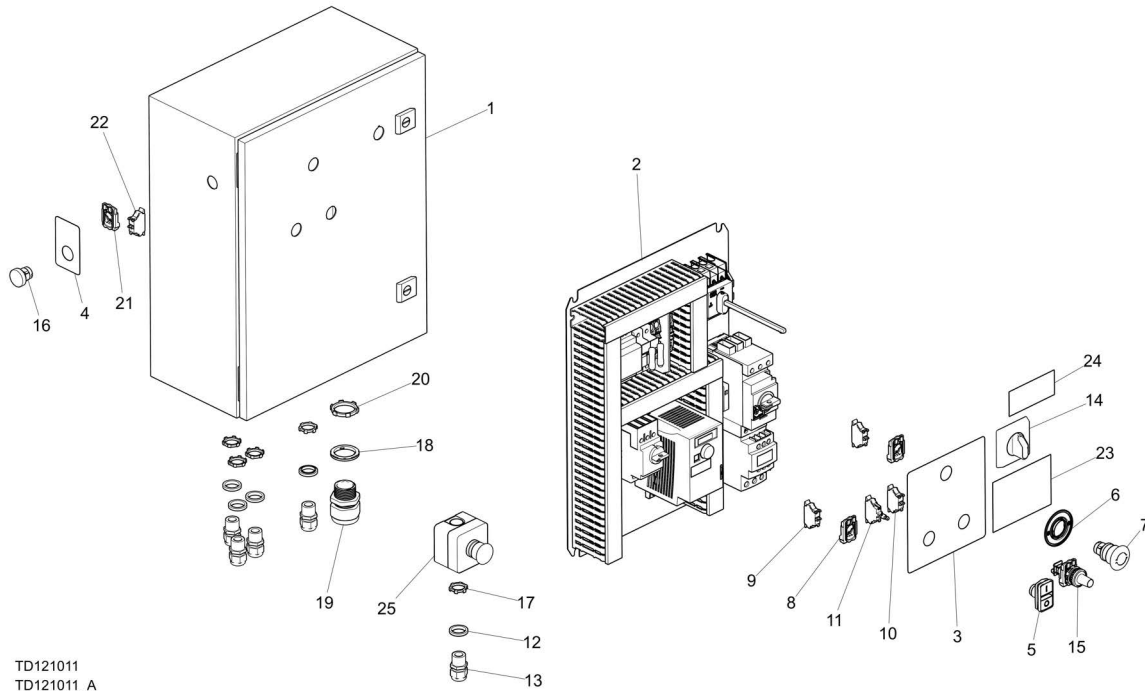

TD121011
TD121011_A

REF	PART #	DESCRIPTION	COMMENTS	QTY.
	121011	Control Assembly, PC200EB 240V 3Ph		1
1	121004	Enclosure, PC200 Control		1
2	121012	Insert Panel Assembly, PC200 240V 3Ph	(See Section 5.14)	1
3	068588	Decal, PC200 Operator Front		1
4	068589	Decal, PC200 Reverse Switch		1
5	068909	Push Button, Grn/Red Marked Flush		1
6	050992	Legend, Ø60mm E-Stop		1
7	068940	Push-Button, Mshrm Mntnd Red TrnRI ZB5		1
	068950	Collar, Mount 1NC ZB5		2
8	068951	Switch Collar, Mount ZB5		2
9	068921	Contact Block, NC ZB5		2
10	068920	Contact Block, NO ZB5		1
11	068910	Light Module, Green ZB5		1
12	E20460	Ring, 1/2 Sealing		5
13	051299	Connector, 1/2" NPT .17-.47		5
14	050883-1	Handle, Disconnect RED/YEL 6mm Shaft		1
15	068582	Potentiometer, 22mm 4.7k Ohm		1
16	068902	Push Button Head, Flush Yellow		1
17	E20461	Nut, 1/2 npt Connector Lock		5
18	053734	Ring, 1" Sealing		1
19	069861	Connector, 1" NPT 0.59-1.00		1
20	053735	Nut, 1" NPT Connector Lock Sealing		1
	068952	Collar, Mount 1NO ZB5		1
21	068951	Switch Collar, Mount ZB5		1
22	068920	Contact Block, NO ZB5		1
23	068573	Decal, Arc Flash Warning		1
24	121011-NPLBL	Label, PC200EB NamePlate		1
25	052999	E-Stop Box, 40mm Oper-10A NC		1

5 Replacement Parts
Control Assembly, PC200EB 240V 3Ph

REF	PART #	DESCRIPTION	COMMENTS	QTY.
	127301	Cable Assy, PC200EB Blade Motor		1
	127304	Cable Assy, PC200 Feed Motor		1
	127307	Cable Assy, PC200 Upper Blade Guard LS1		1
	127308	Cable Assy, PC200 Upper Blade Guard LS2		1
	127309	Cable Assy, PC200 Remote E-Stop		1
	121011-NPLBL	Label, PC200EB Nameplate		1
	121011-WLBL2	Label Set, PC200EB Control Assy Wires		1
	052501	Boot, Clear Sealing ZB Sw		1

5.14 INSERT PANEL ASSEMBLY, PC200 240V 3PH

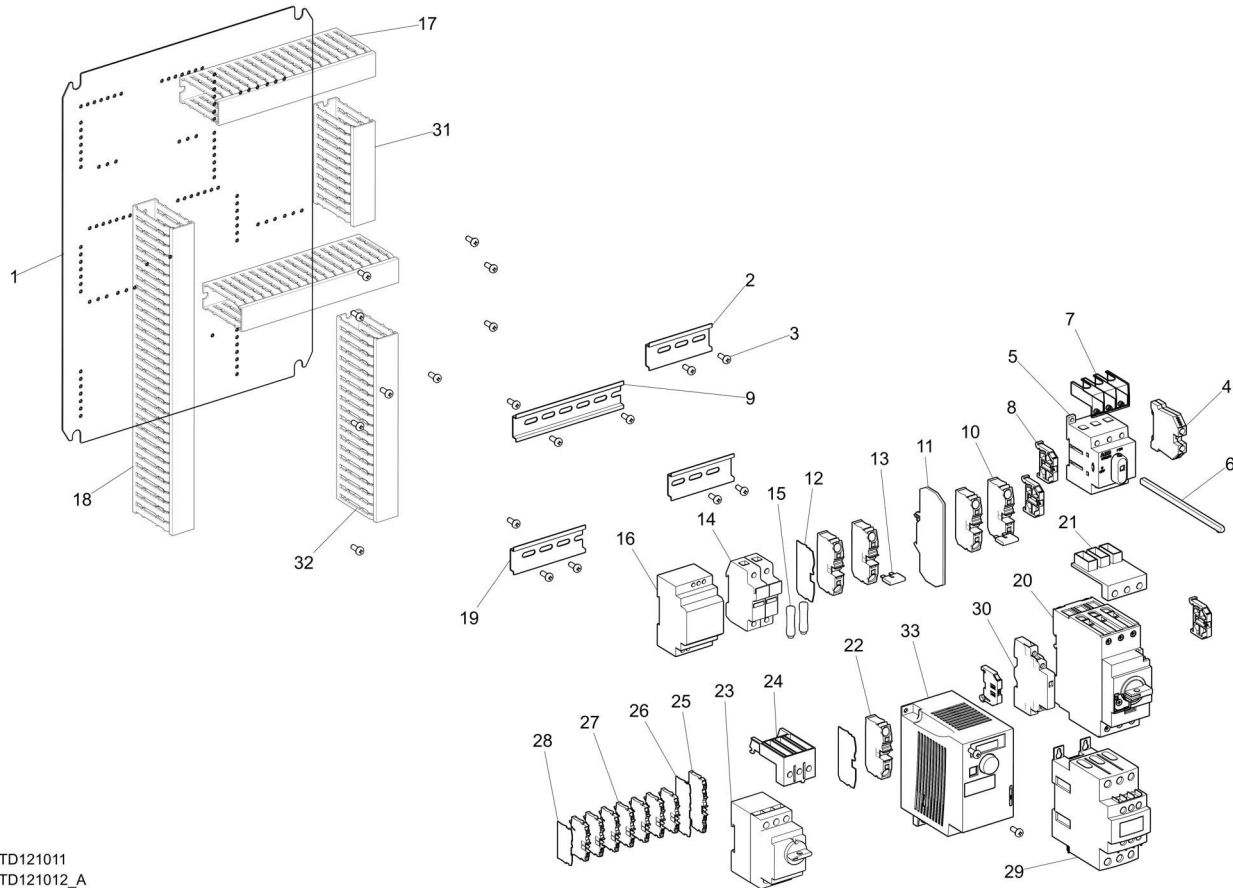

TD121011
TD121012_A

REF	PART #	DESCRIPTION	COMMENTS	QTY.
	121012	Insert Panel Assembly, PC200 240V 3Ph		1
1	121004_1	Insert Panel, PC200		1
2	024474_3_5	DIN RAIL, 3.50 LG		2
3	F05015-17	Bolt, #10-24x1/2 PH		21
4	052525	Terminal Block, 4ga GND		1
5	050881-1	Disconnect, 63A 600V 3P 6mm Shaft		1
6	051673-1_6_25	Shaft, Disconnect 6.25in		1
7	078289	Disconnect, 63A Terminal Shroud		1
8	051986	Din Clamp, Screwless		4
9	024474-6	DIN RAIL, 6 LG		1
10	121007	Terminal Block, 2 Pos 16mm Clamp		4
11	121008	Terminal, Seperator		1
12	068112	Terminal Block, 2Pos 16mm End Plate		2
13	121013	Jumper, 2pos, 16mm		2
14	052512	Fuseholder, 2P Class CC Finger Safe		1
15	052446	Fuse, 2A 600V KLDR Class CC		2
16	114017	Power Supply, 60W 24VDC		1
17	050735_8_75	Cable Duct, 3H x 1W x 8.75L Open Slot WHT		2
18	050735_15_5	Cable Duct, 3H x 1W x 15.5L Open Slot WHT		1
19	024474-4	DIN RAIL, 4 LG		1
20	078474	Motor Protector, 30-40A Manual GV3		1
21	078510	Motor Protector, GV3 Line Phase Cover		1
22	068111	Terminal Block, 2 Pos 16mm GND Clamp		1

5 Replacement Parts
Insert Panel Assembly, PC200 240V 3Ph

REF	PART #	DESCRIPTION	COMMENTS	QTY.
23	102502	Motor Protector, 4.0-6.3 Manual		1
24	068098	Motor Protector, Line Side Barrier		1
25	068104	Terminal Block, 4Pos 1.5mm GND Clamp		1
26	068105	Terminal Block, 4Pos 1.5mm End Plate		1
27	068100	Terminal Block, 2Pos 1.5mm Clamp		7
28	068102	Terminal Block, 2Pos 1.5mm End Plate		1
29	053598	Contact, 65A 3P 24VDC D-A Series		1
30	073509	Auxillary Contact, GVAM11 Short Circuit		1
31	050735_5	Cable Duct, 3H x 1W x 5L Open Slot WHT		1
32	050735_9_25	Cable Duct, 3H x 1W x 9.25L Open Slot WHT		1
33	121020	AC Drive Assembly, PC200EA/EB Feed		1
	121012-TLBL	Label Set, PC200EB Terminal Block		1
	121011-CLBL	Label Set, PC200EB Components		1
	121012-WLBL2	Label Set, PC200EB Insert Wires		1

5.15 CONTROL ASSEMBLY, PC200EB 240V 3PH

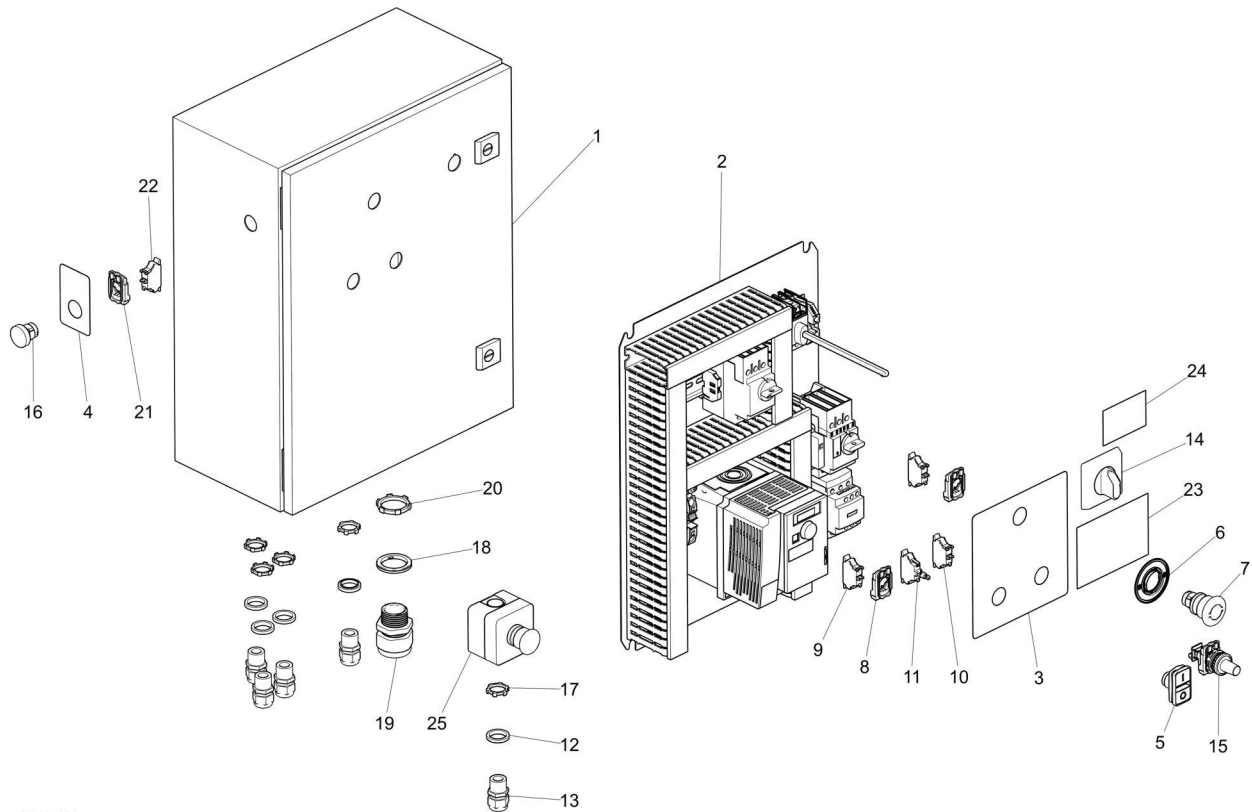

TD121022
TD121022_A

REF	PART #	DESCRIPTION	COMMENTS	QTY.
	121022	Control Assembly, PC200EC 480V 3Ph		1
1	121004	Enclosure, PC200 Control		1
2	121023	Insert Panel Assembly, PC200 480V 3Ph	(See Section 5.16)	1
3	068588	Decal, PC200 Operator Front		1
4	068589	Decal, PC200 Reverse Switch		1
5	068909	Push Button, Grn/Red Marked Flush		1
6	050992	Legend, Ø60mm E-Stop		1
7	068940	Push-Button, Mshrm Mntnd Red TrnRI ZB5		1
	068950	Collar, Mount 1NC ZB5		2
8	068951	Switch Collar, Mount ZB5		2
9	068921	Contact Block, NC ZB5		2
10	068920	Contact Block, NO ZB5		1
11	068910	Light Module, Green ZB5		1
12	E20460	Ring, 1/2 Sealing		5
13	051299	Connector, 1/2" NPT .17-.47		5
14	050883-1	Handle, Disconnect RED/YEL 6mm Shaft		1
15	068582	Potentiometer, 22mm 4.7k Ohm		1
16	068902	Push Button Head, Flush Yellow		1
17	E20461	Nut, 1/2 npt Connector Lock		5
18	053734	Ring, 1" Sealing		1
19	069861-1	Connector, 1" NPT 0.49-0.785		1
20	053735	Nut, 1" NPT Connector Lock Sealing		1
	068952	Collar, Mount 1NO ZB5		1
21	068951	Switch Collar, Mount ZB5		1

5 Replacement Parts
Control Assembly, PC200EB 240V 3Ph

REF	PART #	DESCRIPTION	COMMENTS	QTY.
22	068920	Contact Block, NO ZB5		1
23	068573	Decal, Arc Flash Warning		1
24	121022-NPLBL	Label, PC200EC Electrical Nameplate		1
25	052999	E-Stop Box, 40mm Oper-10A NC		1
	127305	Cable Assy, PC200EC Blade Motor		1
	127304	Cable Assy, PC200 Feed Motor		1
	127307	Cable Assy, PC200 Upper Blade Guard LS1		1
	127308	Cable Assy, PC200 Upper Blade Guard LS2		1
	127309	Cable Assy, PC200 Remote E-Stop		1
	121022-WLBL2	Label Set, PC200EC Control Assy Wires		1
	052501	Boot, Clear Sealing ZB Sw		1

5.16 INSERT PANEL ASSEMBLY, PC200 240V 3PH

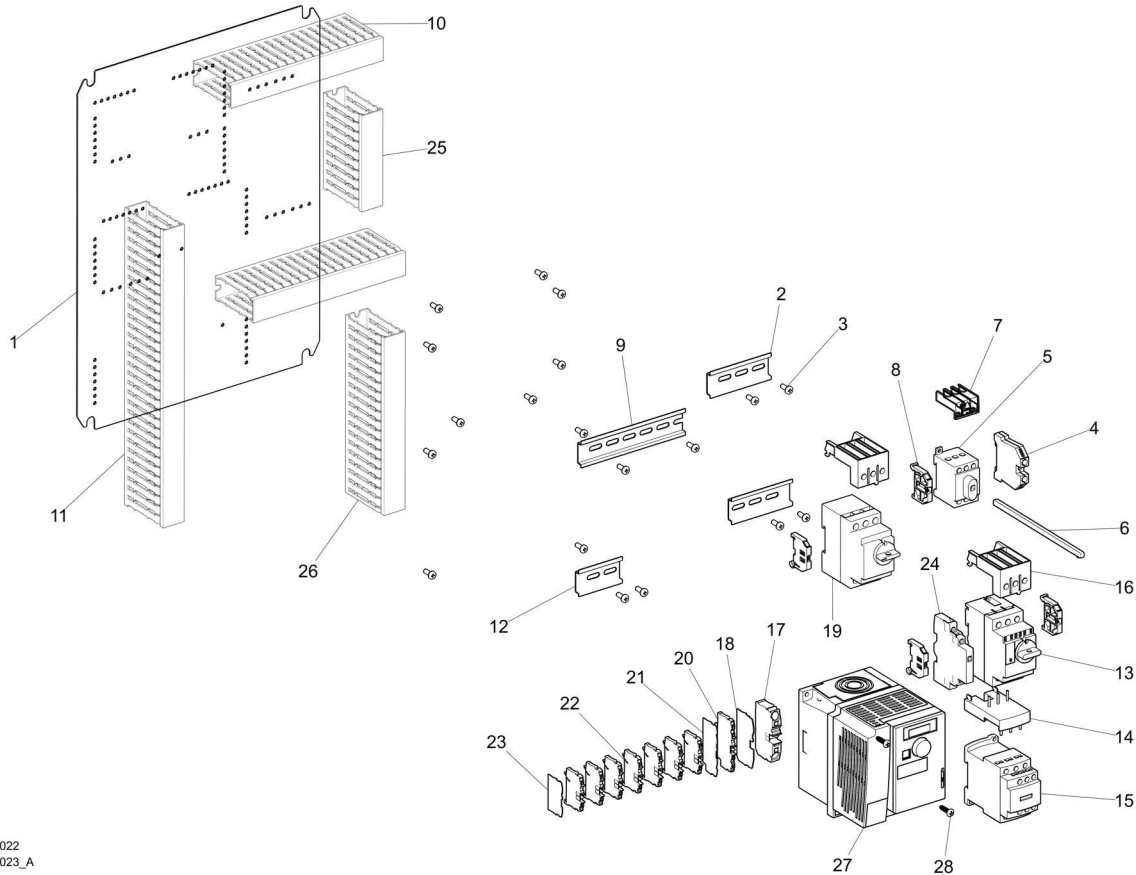

TD121022
TD121023_A

REF	PART #	DESCRIPTION	COMMENTS	QTY.
	121023	Insert Panel Assembly, PC200 480V 3Ph		1
1	121004_1	Insert Panel, PC200		1
2	024474_3_5	DIN RAIL, 3.50 LG		2
3	F05015-17	Bolt, #10-24x1/2 PH		19
4	052525	Terminal Block, 4ga GND		1
5	050903-1	Disconnect, 40A 3Ph Non-Fused		1
6	051673-1_7	Shaft, Disconnect 7in		1
7	068464	Terminal Shroud, 40A ABB Disconnect		1
8	051986	Din Clamp, Screwless		5
9	024474-6	DIN RAIL, 6 LG		1
10	050735_8_75	Cable Duct, 3H x 1W x 8.75L Open Slot WHT		2
11	050735_15_5	Cable Duct, 3H x 1W x 15.5L Open Slot WHT		1
12	024474-2_5	DIN RAIL, 2.55 LG		1
13	068583	Motor Protector, 13-18A Manual		1
14	068099	Motor Protector, Interconnect LC1D09-25		1
15	024911	Contact, 18A 3 Pole 24V Low Pwr Coil		1
16	068098	Motor Protector, Line Side Barrier		2
17	068111	Terminal Block, 2 Pos 16mm GND Clamp		1
18	068112	Terminal Block, 2Pos 16mm End Plate		1
19	523238	Motor Protector, 1.6-2.5A Manual		1
20	068104	Terminal Block, 4Pos 1.5mm GND Clamp		1
21	068105	Terminal Block, 4Pos 1.5mm End Plate		1
22	068100	Terminal Block, 2Pos 1.5mm Clamp		7

REF	PART #	DESCRIPTION	COMMENTS	QTY.
23	068102	Terminal Block, 2Pos 1.5mm End Plate		1
24	073509	Auxillary Contact, GVAM11 Short Circuit		1
25	050735_5	Cable Duct, 3H x 1W x 5L Open Slot WHT		1
26	050735_9_25	Cable Duct, 3H x 1W x 9.25L Open Slot WHT		1
27	121026	AC Drive Assembly, PC200EC Feed		1
28	F05015-43	Screw, #10-24x3/4 Ph Pan Hd, Type F Zinc		2
	121022-CLBL	Label Set, PC200 Components		1
	121023-TLBL	Label Set, PC200EC Terminal Block		1
	121023-WLBL2	Label Set, PC200EC Insert Wires		1

5.17 Blade Assembly

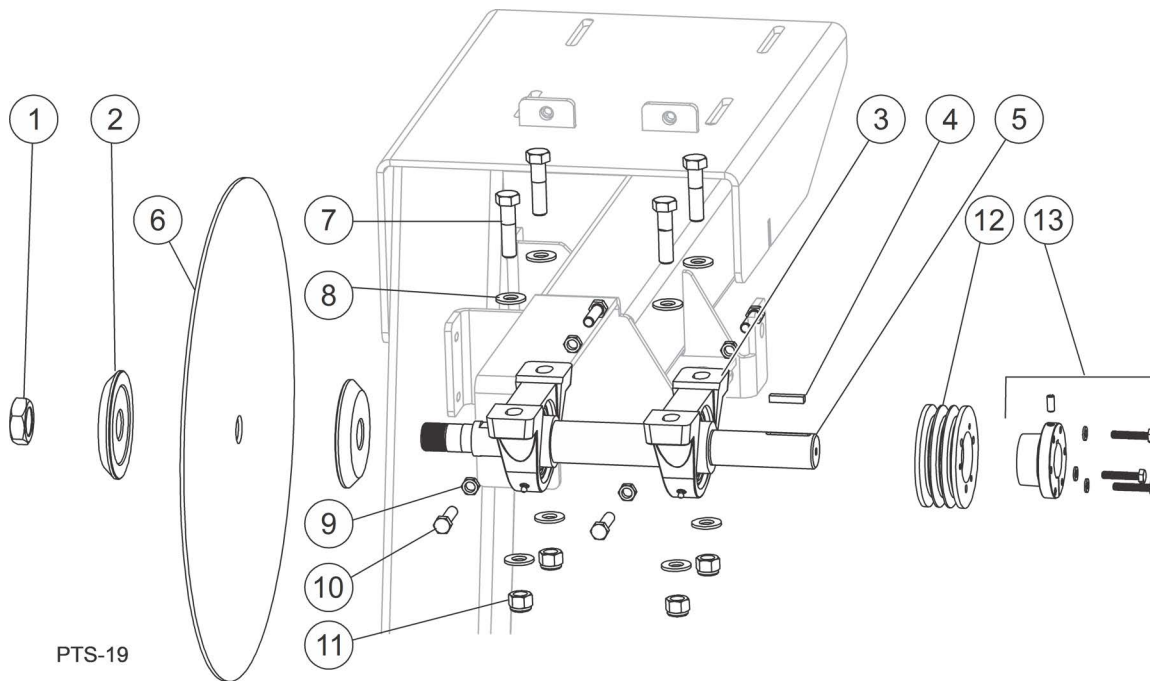

REF	PART #	DESCRIPTION	COMMENTS	QTY.
	133258	ASSY, 18" CIRCULAR SAW ARBOR A1.05		1
1	F05010-172	Nut, 1-14 Hex LH Jam Zinc		1
2	119080	Collar, PC200 Saw		2
3	122566	Bearing, 1-1/4" Pillow Block NAP206-20		2
4	017832	Key, 1/4Sq x1 3/8		1
5	133257	Shaft, PC200, Blade A1.05		1
6	TRN457.036.25.4	Blade, 18"x36T Circle Saw PC200		1
7	F05008-76	Bolt, 1/2-13x2 HH		4
8	F05011-2	Washer, 1/2 SAE Flat		4
9	F05010-29	Nut, 3/8-16 Jam		4
10	F05007-17	Bolt, 3/8-16 x 1 1/2 HH FT Znc		4
11	F05010-8	Nut, 1/2-13 Nyl Hex Lock		4
12	133381	Sheave, 3/3V 315 SH		1
13	119082	Bushing, SH 1-1/4		1