

Pallet Dismantler Conveyor

Safety, Operation, Maintenance & Parts Manual

Single Drive Belt Conveyor

A1.01

Safety is our #1 concern!

Form #2346

MODELS EFFECTED:

Single Phase	3-Phase
CP-10B-EAM2U	CP-10B-EBC2U
CP-15B-EAM2U	CP-15B-EBC2U
CP-20B-EAM2U	CP-20B-EBC2U
CP-25B-EAM2U	CP-25B-EBC2U
CP-30B-EAM2U	CP-30B-EBC2U
CP-35B-EAM2U	CP-35B-EBC2U
CP-40B-EAM2U	CP-40B-EBC2U
CP-45B-EAM2U	CP-45B-EBC2U



WARNING! Read and understand this manual before using this machine.

California

Proposition 65 Warning



WARNING: Drilling, sawing, sanding or machining wood products can expose you to wood dust, a substance known to the State of California to cause cancer. Avoid inhaling wood dust or use a dust mask or other safeguards for personal protection.

For more information go to **www.P65Warnings.ca.gov/wood**.

Active Patents assigned to Wood-Mizer, LLC

Wood-Mizer, LLC has received patents that protect our inventions which are a result of a dedication to research, innovation, development, and design. Learn more at: woodmizer.com/patents

©April 6, 2023 Wood-Mizer LLC

Printed in the United States of America, all rights reserved. No part of this manual may be reproduced in any form by any photographic, electronic, mechanical or other means or used in any information storage and retrieval system without written permission from

Wood-Mizer, LLC

8180 West 10th Street

Indianapolis, Indiana 46214

SECTION 1 INTRODUCTION

1.1 About This Manual 1-1
 1.2 Getting Service..... 1-1
 1.3 Specifications 1-1

SECTION 2 GENERAL SAFETY

2.1 Safety Symbols 2-1
 2.2 Safety Instructions..... 2-1
 Observe ALL Safety Instructions..... 2-1
 2.3 Electrical Lockout Procedures 2-2

SECTION 3 SETUP

3.1 Incline Section..... 3-1
 Legs 3-1
 Support Frame..... 3-1
 Rollers 3-1
 Incline Drive 3-2
 3.2 Horizontal Section..... 3-3
 Side Panels 3-3
 Rollers 3-3
 Drive 3-3
 3.3 Middle Section 3-3
 Side Panels 3-3
 3.4 Tail Section 3-4
 Side Panels 3-4
 Connect Middle to the Tail Section 3-4
 Belt 3-4
 3.5 Motor..... 3-4

SECTION 4 MAINTENANCE

4.1 Daily Maintenance 4-1
 Check the Rollers 4-1
 Check Belt Wear..... 4-1
 4.2 Every 200 Hours 4-1
 Lubrication 4-1
 4.3 Monthly Maintenance 4-1
 Drive Chain Tension 4-1
 Belt Alignment..... 4-1
 4.4 Quarterly Maintenance..... 4-1
 Gearbox Oil 4-1
 4.5 Bi-annual (6000 hrs) Maintenance..... 4-1
 Change Gearbox Oil 4-1

SECTION 5 REPLACEMENT PARTS

5.1 How To Use The Parts List..... 5-1
 5.2 Torque Values 5-2
 5.3 Incline Conveyor, Drive Section..... 5-3
 5.4 Incline Support Frame..... 5-5

Table of Contents

Section-Page

5.5	Conveyor Middle Section.....	5-6
5.6	Middle Sections.....	5-7
5.7	Tail Section	5-8

SECTION 6 SETUP

6.1	Contents of the Parts Bags.....	6-1
6.2	Part Quantity per Conveyor Size.....	6-1
	<i>Standardized conveyor size.....</i>	<i>6-1</i>
6.3	Remove and inspect the parts boxes	6-1

Wood-Mizer® LLC
Limited Product Warranty



Wood-Mizer LLC (“Warrantor”), an Indiana corporation with its principal place of business at 8180 West Tenth Street, Indianapolis, IN 46214-2400 USA, warrants to the purchaser (“Purchaser”) that for the time periods specifically stated herein and subject to the terms, conditions and limitations stated herein, the equipment manufactured by the Warrantor will be free from defects in material and workmanship attributable to Warrantor so long as, during the warranty periods stated herein, the equipment is installed, operated and maintained in accordance with the instructions provided by Warrantor.

PRODUCT	MODEL CLASS	LENGTH OF WARRANTY		EFFECTIVE DATE
		USA & CANADA	NON USA & CANADA	
Portable Sawmills, Resaws, Edgers	LT, LX, HR, EG	Two years	One year	Date of purchase
Portable Sawmills with Chassis	LT28, LT35, LT40, LT50, LT70, LX450	Two years, excluding the chassis, which chassis shall have a five year warranty	One year	
Industrial Sawmills, Resaws, Edgers	WM, HR, EG, TVS, SVS	One year	One year	Date of purchase or date of installation / training (if applicable), whichever occurs first, not to exceed 6 months from date of purchase
TITAN Industrial	WB, TV, HR, EG, EA, MR	One year	One year	
Material Handling	TWC, IC, TD, LD, GC, CR, CB, CC	One year	One year	
Blade Maintenance Equipment	BMS, BMT, BMST	One year	One year	Date of purchase
Options and Accessories	Various	One year*	One year*	
Moulders, Extractors, Kilns	MP, MD, KS, KD	One year	One year	
Slab Flatteners	MB	Two years	One year	
Pallet Equipment	PD, PC	One year	One year	
Log Splitters	FS	One year	One year	
Replacement Parts	Various	90 days	90 days	

* Warranty on Options will match the warranty on the primary equipment when purchased on same invoice.

Exclusions from 90 Day, Limited One Year and Two Year Warranty

Warrantor shall have no responsibility under this warranty for any wear components, including, but not limited to: belts, blade guides, blades, electric motor brushes, drum switches, filters, fuses, hoses, bearings (excluding cylindrical drive bearings), bushings, cable carriers, and spark plugs. All wear components are furnished “as is”, without any warranty from Warrantor. This limited warranty does not cover any defects caused by misuse, negligence, alterations, damage due to overload, abnormal conditions, excessive operation, accident, or lack of performance of normal maintenance services.

Several components which are used in the manufacture of the equipment but not manufactured by Warrantor such as cant hooks, power plants, laser sights, batteries, tires, and trailer axles have warranties provided by the original equipment manufacturer (written copies available upon request). Warrantor does not separately warrant such items. Components or equipment manufactured by third parties are not covered by this warranty. Warrantor, however, will provide reasonable assistance to the Purchaser to make claims against any warranties applicable to such component parts as provided by such original equipment manufacturers. Components or equipment manufactured by third parties are not covered by this Warranty.

Five Year Limited Chassis Warranty

The limited five year chassis warranty described above, DOES NOT extend to (a) any damage stemming from accident, improper towing, overload, abuse, misuse, abnormal conditions, negligence, excessive operation, or lack of maintenance, (b) rust caused by exposure to corrosive atmospheric conditions, or (c) the sawmill head, carriage, axle, brakes, or any hydraulic or electrical components attached to the chassis.

Warrantor’s Obligations as To Defects

In the event that the equipment fails to perform due to defective materials or workmanship attributable to Warrantor under normal use and service within the established warranty period, Purchaser’s sole and exclusive remedy and Warrantor’s sole liability shall be to replace or repair, in Warrantor’s sole and subjective discretion, any defective part at Warrantor’s principal place of business without cost to the Purchaser if such defect exists. The determination of whether a product is defective shall be made by Warrantor in Warrantor’s sole and subjective discretion. The Purchaser must notify Warrantor prior to shipping any defective part. Warrantor, at its sole discretion, may cover expenses incurred in shipping the defective part to Warrantor for evaluation; provided, however, that Warrantor will not be responsible for labor, travel time, mileage, removal, installation or incidental or consequential damages. However, any part in excess of 140 pounds must be returned by the Purchaser, to the Warrantor’s nearest authorized facility at the Purchaser’s expense, if return is requested by Warrantor. Warrantor shall have a reasonable time within which to replace or repair the defective part. If Warrantor determines that the product is not defective under the terms of this warranty in Warrantor’s sole and subjective discretion, then Purchaser shall be responsible for any expenses incurred by Warrantor in returning the equipment to the Purchaser.

Limitations and Disclaimers of Other Warranties

EXCEPT FOR THE EXPRESS WARRANTY PROVISIONS STATED ABOVE, WARRANTOR DISCLAIMS ALL WARRANTIES, EXPRESS AND/OR IMPLIED, INCLUDING WITHOUT LIMITATION, THE IMPLIED WARRANTIES OF MERCHANTABILITY, AND FITNESS FOR A PARTICULAR PURPOSE, NONINFRINGEMENT AND TITLE. No representation or other affirmation of fact by representatives of Warrantor, whether verbal or in writing, including photographs, brochures, samples, models, or other sales aids, shall constitute a warranty or other basis for any legal action against Warrantor. There are no other representations, promises, agreements, covenants, warranties, guarantees, stipulations or conditions, express or implied, by Warrantor except as expressly set forth herein. THE ORIGINAL PURCHASER AND ANY INTENDED USER OR BENEFICIARY OF THIS EQUIPMENT, SHALL NOT BE ENTITLED TO RECOVER ANY INDIRECT, SPECIAL, PUNITIVE, EXEMPLARY, CONSEQUENTIAL, SPECIAL, OR INCIDENTAL DAMAGES OR LOSSES, INCLUDING BUT NOT LIMITED TO, DAMAGES OF LOST PRODUCTION, LOST REVENUE, LOST PRODUCT, LOST PROFITS, LOST BUSINESS, LOSS OF USE, LOSS OF GOODWILL, OR BUSINESS INTERRUPTION, FROM WARRANTOR FOR ANY REASON WHATSOEVER INCLUDING WITHOUT LIMITATION WARRANTY OR DEFECT IN THE PRODUCT REGARDLESS OF THE SOLE, JOINT AND/OR CONCURRENT NEGLIGENCE, BREACH OF CONTRACT, BREACH OF WARRANTY, STRICT LIABILITY IN TORT OR STATUTORY CLAIMS OR OTHER LEGAL FAULT OR RESPONSIBILITY OF EITHER WARRANTOR OR PURCHASER OR ITS EMPLOYEES OR AGENTS. Warrantor does not warrant that its equipment meets or complies with the requirements of any particular safety code or governmental requirements.

Defective items replaced under the terms of this warranty become the property of Warrantor.

Design Changes

Warrantor reserves the right to change the design of its products from time to time without notice and without obligation to make corresponding changes in or to its products previously manufactured.

Rights of Purchasers

The validity and effect of this limited warranty as well as its interpretation, operation and effect, shall be determined exclusively by the principles of law and equity of the State of Indiana, USA. This limited warranty gives Purchaser specific legal rights. Purchaser may also have other rights, which may vary from state to state. Some states may not allow limitations as to the duration of implied warranties or to the exclusion or limitation of incidental or consequential damages, so some of the limitations and exclusions detailed set forth above may not apply. In the event that any one or more of the provisions of this warranty shall be or become invalid, illegal or unenforceable in any respect, the validity, legality and enforceability of the remaining provisions of this warranty shall not be affected thereby.

Interpretations

This Warranty constitutes the entire warranty agreement between Warrantor and Purchaser and supersedes any prior understandings or agreements pertaining to the same subject matter. This warranty cannot be amended except in writing which refers to this warranty which is signed by both Warrantor and Purchaser.

SECTION 1 INTRODUCTION

1.1 About This Manual

This manual replaces any previous information received on your Wood-Mizer® equipment.

The information and instructions in this manual do not amend or extend the limited warranties for the equipment given at the time of purchase.

1.2 Getting Service

For contact information, sales, service, parts, and additional manuals, sign into your account on <https://woodmizer.com>, or call inside the USA: 1-800-553-0182 or from outside the USA: 317-271-1542

1.3 Specifications

Equipment specification are included in the Online Manuals, which are found at <https://apps.woodmizer.com/Manuals/Manuals.aspx?parent=0>.

SECTION 2 GENERAL SAFETY

2.1 Safety Symbols

The following symbols and signal words call your attention to instructions concerning your personal safety. Be sure to observe and follow these instructions.

 **DANGER!** indicates an imminently hazardous situation which, if not avoided, will result in serious injury or death.

 **WARNING!** suggests a potentially hazardous situation which, if not avoided, could result in serious injury or death.

 **CAUTION!** refers to potentially hazardous situations which, if not avoided, may result in minor or moderate injury or damage to equipment.

NOTICE indicates vital information.

2.2 Safety Instructions

OWNER/OPERATOR'S RESPONSIBILITY

The procedures listed in this manual may not include all ANSI, OSHA, or locally required safety procedures. **It is the owner/operator's responsibility and not Wood-Mizer LLC to ensure all operators are properly trained and informed of all safety protocols.** Owner/Operators are responsible for following all safety procedures when operating and performing maintenance to the equipment.

Observe ALL Safety Instructions

NOTICE Read the entire Operator's Manual before operating this equipment.

Note all safety warnings throughout this manual and those posted on the machine.

Be able to access this manual at all times while operating this equipment.

Read additional manufacturer's manuals and observe their applicable safety instructions.

Only persons who have read and understood the entire operator's manual should operate this equipment.

This equipment is not intended for use by or around children.

It is the owner/operator's responsibility to comply with all applicable federal, state, and local laws, rules, and regulations regarding the ownership, operation, and transporting your equipment.

Operators should become thoroughly familiar with and comply with these applicable laws for operating equipment.



WARNING! Clean sawdust from all guards, vents, control boxes, or any area where sawdust may gather **after every shift**. Failure to do so may result in fire, causing death or serious injury.

WEAR SAFETY CLOTHING



WARNING! Secure all loose clothing, hair, and jewelry before operating the equipment.

Always wear eye, ear, and foot protection when operating or servicing the equipment.

EQUIPMENT SETUP



WARNING! Use two or more people when lifting loads heavier than 50 pounds.

Set up the equipment on solid, level ground.

Check the control box and Emergency Stop switches for proper operation prior to each use of the machine.

CHECK EQUIPMENT BEFORE OPERATION



DANGER! Ensure all guards and covers are in place and secured before operating.

KEEP PERSONS AWAY



DANGER! Keep all persons out of the path of moving equipment when operating equipment.

KEEP HANDS AWAY



DANGER! Remove power before clearing debris or any other maintenance activity.



WARNING! Avoid contact with any hot parts (motors).

Allow the system to cool sufficiently before beginning any service function, including debris removal.

Stay a safe distance from rotating members (rollers, sprockets, etc.) and ensure loose clothing or long hair does not engage rotating members

Do not adjust the motor drive chain with the engine running.

Coastdown required. Shut down the conveyor and allow all moving parts to come to a complete stop before removing any guards or covers.

KEEP SAFETY LABELS IN GOOD CONDITION

NOTICE Ensure that all safety decals are clean and readable. Replace all damaged safety decals to prevent personal injury or damage to the equipment. Contact your local distributor, or call your Customer Service Representative to order more decals.

NOTICE If replacing a component that has a safety decal affixed to it, ensure the new component also has the safety decal affixed in the same place.

KEEP AREA CLEAN



WARNING! Maintain a clean and clear path for all necessary movement around the material stacking areas.

Do not allow children in the area.

DISPOSE OF WOOD BY-PRODUCTS PROPERLY

NOTICE Properly dispose of all wood by-products, including sawdust, chips, and other debris, including operation waste such as oil, filters, etc.

2.3 Electrical Lockout Procedures

RULES FOR USING LOCKOUT PROCEDURE

The equipment shall be locked out to protect against accidental or inadvertent operation when such operation could cause injury to personnel. Do not attempt to operate any switch or valve bearing a lock.

LOCKOUT PROCEDURES MUST BE USED DURING, BUT NOT LIMITED TO:

- Changing or adjusting blades
- Unjamming operations
- Cleaning
- Mechanical repair
- Electrical maintenance
- Retrieval of tools/parts from work area
- Activities where guards or electrical panel guard is open or removed

MAINTENANCE HAZARDS INCLUDE, BUT NOT LIMITED TO:

- Blade contact
- Pinch points
- Kickbacks
- Missiles (thrown blades/wood chips)
- Electrical

FAILURE TO LOCKOUT MAY RESULT IN, BUT NOT LIMITED TO:

- Cut
- Crush
- Blindness
- Puncture
- Electrocution
- Serious injury and death
- Amputation
- Burn
- Shock

TO CONTROL MAINTENANCE DANGERS:

- Lockout procedures must be followed (see **OSHA regulation 1910.147**).
- Never rely on machine stop control for maintenance safety (emergency stops, on/off buttons, interlocks).
- Do not reach into moving blades or feed systems. Allow all coasting parts to come to a complete stop.
- Electrical power supply and air supply must both be locked out.
- Where established lockout procedures cannot be used (electrical troubleshooting or mechanical dynamic troubleshooting), alternative effective protective techniques shall be employed which may require special skills and planning.
- Always follow safe operations practices in the workplace.

EQUIPMENT LOCKOUT PROCEDURE

Lockout procedures per OSHA regulation 1910.147, appendix A:

GENERAL

The following simple lockout procedure is provided to assist owner/operators in developing their procedures so they meet the requirements of **OSHA regulation 1910.147**. When the energy isolating devices are not lockable, tagout may be used, provided the owner/operator complies with the provisions of the standard which require additional training and more rigorous periodic inspections. When tagout is used and the energy isolating devices are lockable, the owner/operator must provide full operator protection (see OSHA regulation 1910.147, paragraph (c)(3)) and additional training and more rigorous periodic inspections are required. For more complex systems, more comprehensive procedures may need to be developed, documented, and utilized.

PURPOSE

This procedure establishes the minimum requirements for the lockout of energy isolating devices whenever maintenance or servicing is done on machines or equipment. It shall be used to ensure that the machine or equipment is stopped, isolated from all potentially hazardous energy sources and locked out before personnel perform any servicing or maintenance where the unexpected energization or start-up of the machine or equipment or release of stored energy could cause injury.

COMPLIANCE WITH THIS PROGRAM

All personnel are required to comply with the restrictions and limitations imposed upon them during the use of lockout. The authorized personnel are required to perform the lockout in accordance with this procedure. All operators, upon observing a machine or piece of equipment which is locked out to perform servicing or maintenance shall not attempt to start, energize, or use that machine or equipment.

SEQUENCE OF LOCKOUT

1. Notify all affected personnel that servicing or maintenance is required on a machine or equipment and that

the machine or equipment must be shut down and locked out to perform the servicing or maintenance.

2. The authorized employee shall refer to the company procedure to identify the type and magnitude of the energy that the machine or equipment utilizes, shall understand the hazards of the energy, and shall know the methods to control the energy.
3. If the machine or equipment is operating, shut it down by the normal stopping procedure (depress the stop button, open switch, close valve, etc.).
4. De-activate the energy isolating device(s) so that the machine or equipment is isolated from the energy source(s).
5. Lock out the energy isolating device(s) with assigned individual lock(s).
6. Stored or residual energy (such as that in capacitors, springs, elevated machine members, rotating fly-wheels, hydraulic systems, and air, gas, steam, or water pressure, etc.) must be dissipated or restrained by methods such as grounding, repositioning, blocking, bleeding down, etc.
7. Ensure that the equipment is disconnected from the energy source(s) by first checking that no personnel are exposed, then verify the isolation of the equipment by operating the push button or other normal operating control(s) or by testing to make certain the equipment will not operate.



CAUTION! Return operating control(s) to neutral or "off" position after verifying the isolation of the equipment.

8. The machine or equipment is now locked out.

RESTORING EQUIPMENT TO SERVICE

When the servicing or maintenance is completed and the machine or equipment is ready to return to normal operating condition, the following steps shall be taken.

1. Check the machine or equipment and the immediate area around the machine to ensure that nonessential items have been removed and that the machine or equipment components are operationally intact.
2. Check the work area to ensure that all personnel have been safely positioned or removed from the area.
3. Verify that the controls are in neutral.
4. Remove the lockout devices and re-energize the machine or equipment.

NOTE: The removal of some forms of blocking may require re-energization of the machine before safe removal.

5. Notify affected personnel that the servicing or maintenance is completed and the machine or equipment is ready for use.

PROCEDURE INVOLVING MORE THAN ONE PERSON

In the preceding steps, if more than one individual is required to lock out the equipment, **each shall place his own personal lock on the energy isolating devices.**

SECTION 3 SETUP

3.1 Incline Section

The incline section should be assembled at its

NOTE: When in doubt of which fasteners to use, see the Parts Section.

Legs

1. Assemble the frame legs to the upper frame at the expected height of the finished incline as shown in FIG. 3-1.

The leg height/bed angle are adjustable.

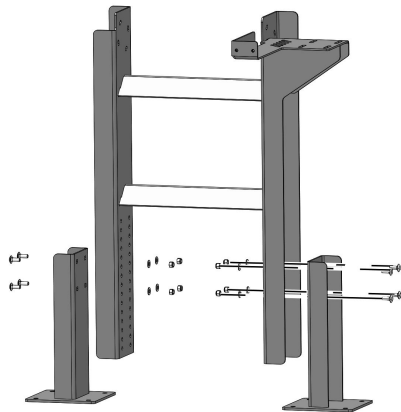

FIG. 3-1

2. Assemble the side panels to both the upper and lower belt channels.
3. Assemble the feet of the lower incline section as shown in FIG. 3-2.

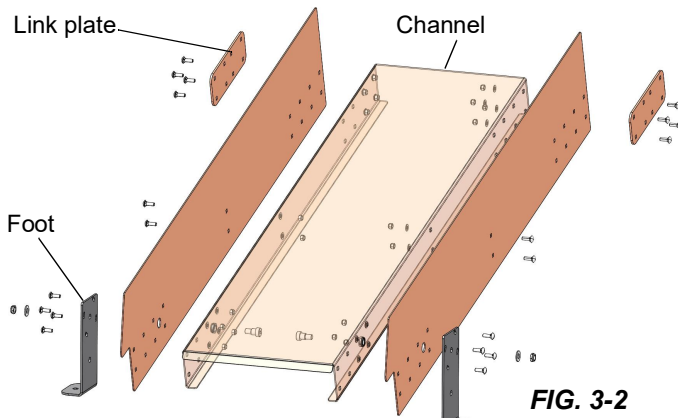

FIG. 3-2

4. Connect the two halves of the Incline Section with the link plates.



WARNING! Use two-man lift for parts over 50lbs.



NOTE: The front support and rear feet have slots for adjustment. Loosen the bolts and adjust as necessary to vertically plumb the supports and feet. Use shims (not included) to level the conveyor.

Support Frame

NOTE: The incline section must be supported during assembly.

1. Install the assembled incline section to the frame as shown in FIG. 3-3.

The height can be adjusted later, if needed.

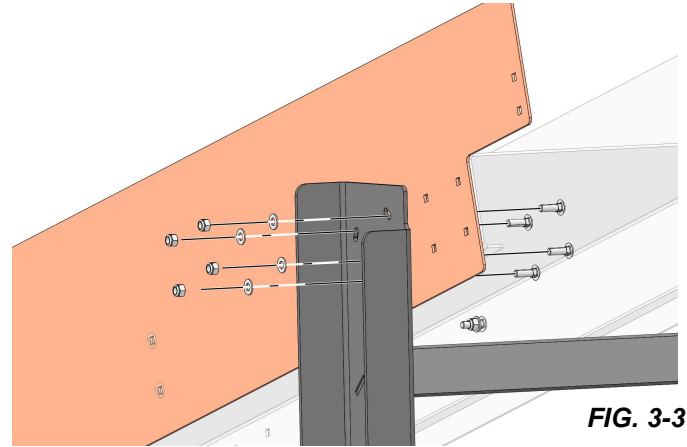

FIG. 3-3

Rollers

1. Install the drive roller (longer shaft) and all the hardware on the side where the support frame was mounted as shown in FIG. 3-4.

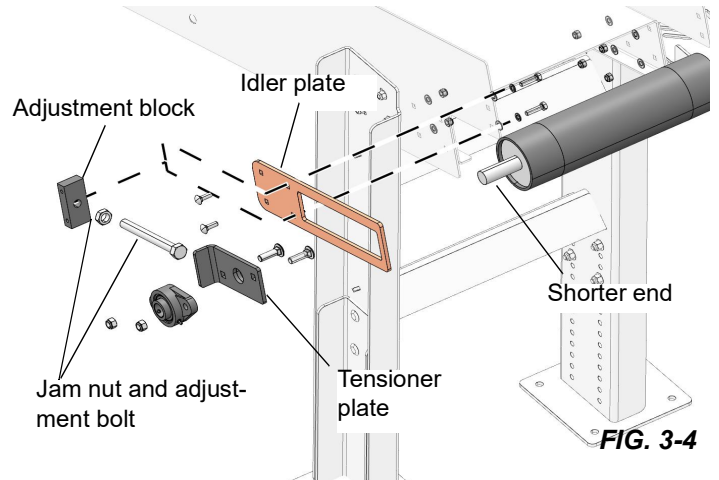

FIG. 3-4

2. Install the idler plate and adjustment block.
3. Thread the jam nut on to the adjustment bolt.
4. Thread the adjustment bolt deeply into the adjustment block.

5. Install the roller mounting plate on the motor side as shown in FIG. 3-5.

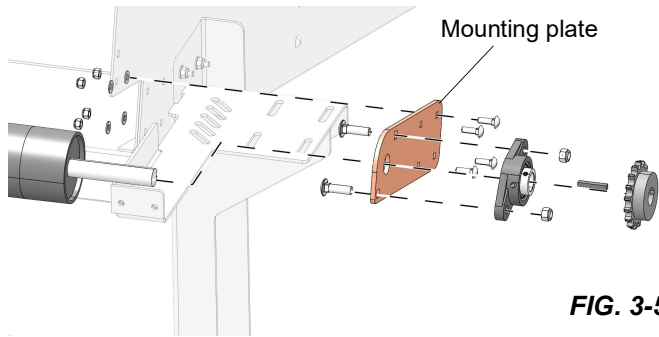

FIG. 3-5

6. Set the roller in place.
7. Loosen both set screws on the bearing.
8. Slide the long end of the drive roller into the bearing.
9. Mount the bearing onto the mounting plate.
10. Loosen both set screws on the sprocket.
11. Place the sprocket with the key onto the roller shaft.
12. Assemble the idle side bearing on the tensioner plate as shown in FIG. 3-4.

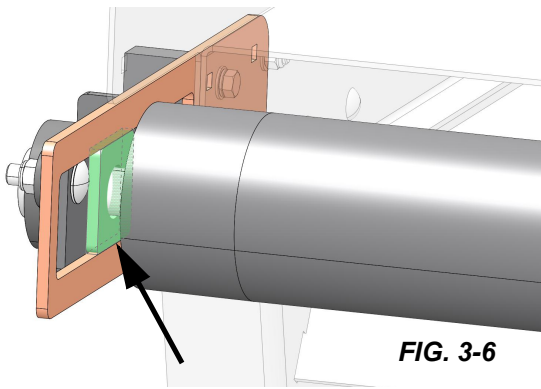

FIG. 3-6

13. Ensure the tensioner plate fits snugly into the idler plates as shown in FIG. 3-6.
 14. Ensure the roller is parallel to the belt channel.
 15. Tighten the bearing set screws on both sides.
 16. Snug the adjustment bolt up to the idler tensioner.
- These adjustments may change when the belt is installed.

Incline Drive

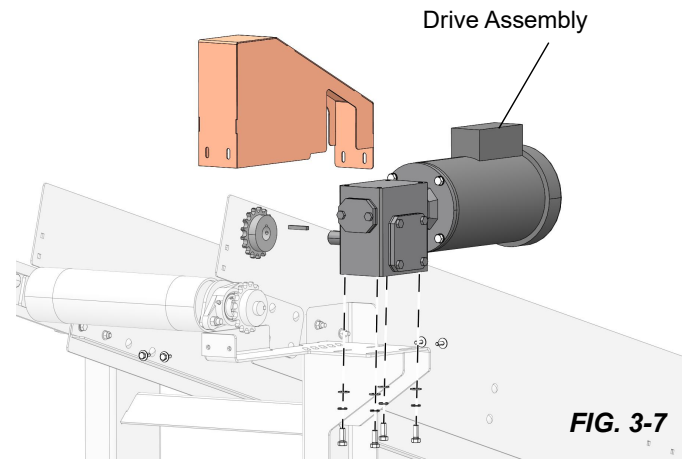

FIG. 3-7

1. Loosen both set screws on the drive sprocket to slide the sprocket and key onto the drive shaft.

NOTE: Do not tighten the drive assembly mount bolts until the drive chain is installed and properly tensioned.

2. Install the drive assembly to support platform on the frame of the conveyor as shown in FIG. 3-9.
3. Ensure the roller sprocket and drive sprocket are aligned as shown in FIG. 3-8.

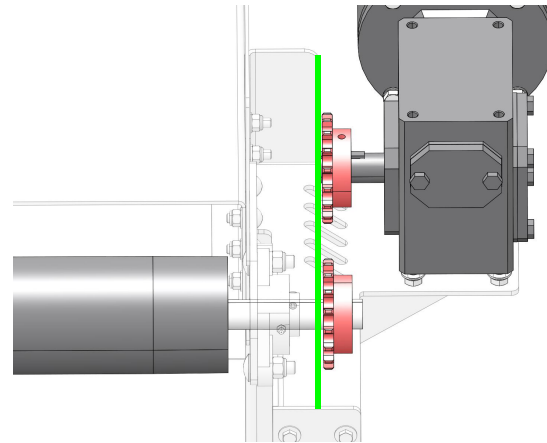

FIG. 3-8

4. Tighten the sprocket set screws when properly aligned.
5. Use the master chain link to install the drive chain around the roller sprocket and drive sprocket.
6. Adjust the drive assembly to allow a 1/2 in (12mm) sag in the drive chain.



CAUTION! Do not over-tension the conveyor drive chain. Damage to the gearbox will occur.

7. Tighten the mount bolts to secure the drive assembly in place.
8. Install the drive cover to the framework as shown in FIG. 3-7.

3.2 Horizontal Section

Side Panels

Install the conveyor side panels and feet as shown in FIG. 3-9.

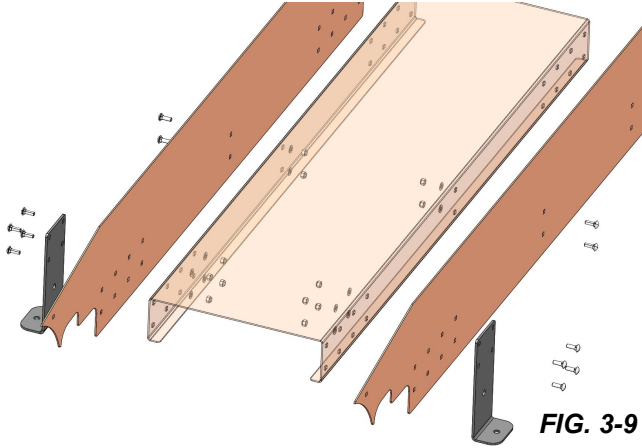

FIG. 3-9

Rollers

Install two belt rollers and two guard rollers as shown in FIG. 3-10.

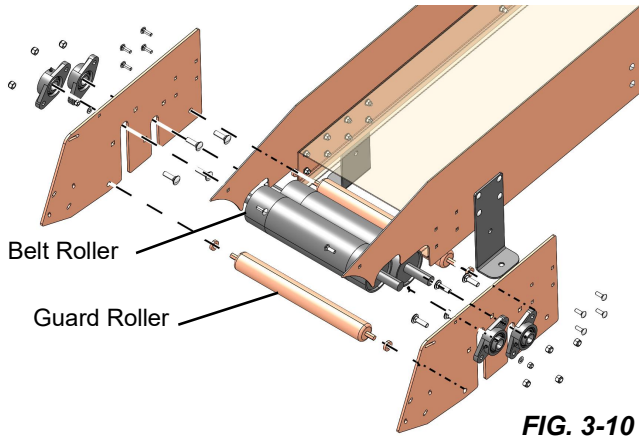

FIG. 3-10

NOTE: Guard roller do not have exterior fasteners, only interior spacers.

Drive

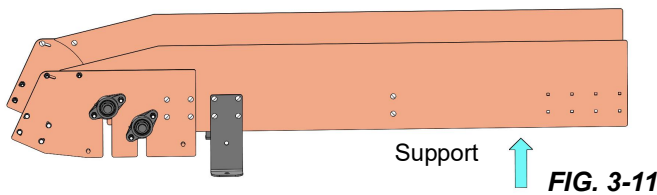

FIG. 3-11

1. Support the rear of the section.
2. Move the section into place next to the incline section.

3. Fasten the incline section to the first horizontal section as shown in FIG. 3-12. .

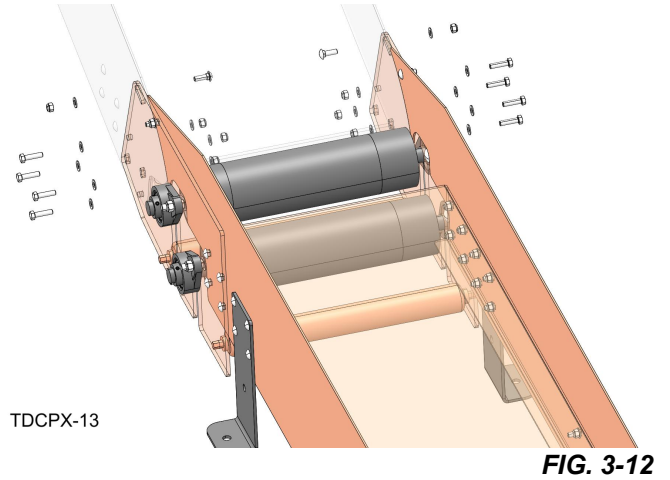

FIG. 3-12

3.3 Middle Section

Side Panels

1. Install the conveyor side panels, link plates, feet, and roller for the Middle section as shown in FIG. 3-13.

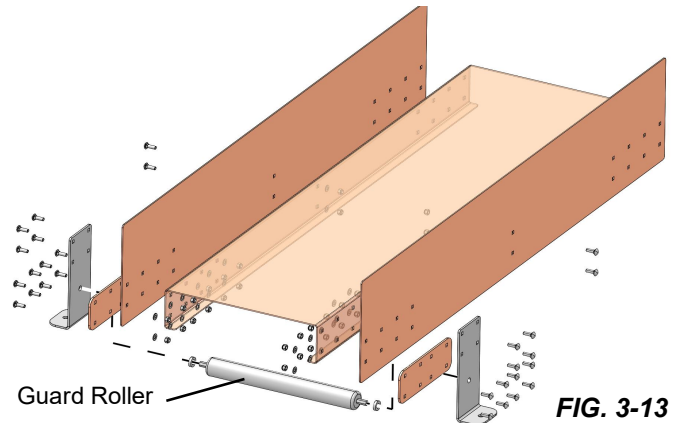

FIG. 3-13

2. Support the rear of the section and move into place next to the horizontal section.

NOTE: The horizontal section may be connected to a tail Section without a middle section.

3. Connect the middle section to the horizontal section with the link plates .

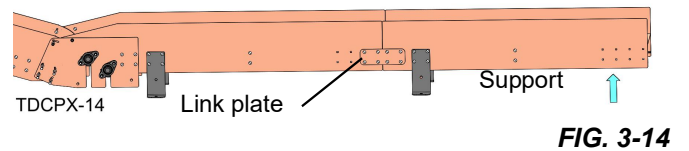

FIG. 3-14

3.4 Tail Section

Side Panels

1. Repeat the assembly process used for the other sections for the panels and both feet with rollers.
2. Repeat the idle side roller installation to both sides of the lower half of the incline section.

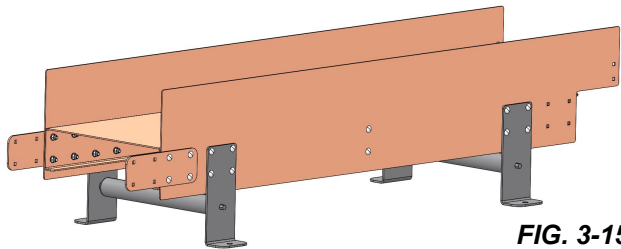

FIG. 3-15

3. Install a roller and all the hardware to the end of the conveyor assembly as shown in FIG. 3-16.

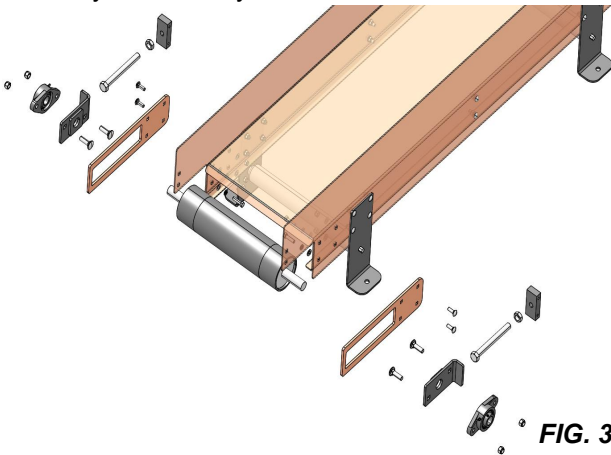

FIG. 3-16

Connect Middle to the Tail Section

NOTE: The tail section may be connected to a middle section or directly to a drive section.

1. Connect those sections in the same way as it was in horizontal and middle case.

Belt

1. Route the belt around the tail rollers as shown in FIG. 3-17.

NOTE: The belt is routed **over** the guard rollers on the feet but under the one shown in FIG. 3-17.

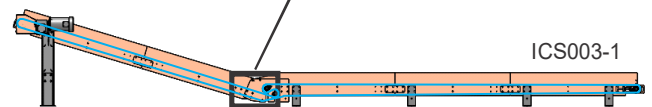
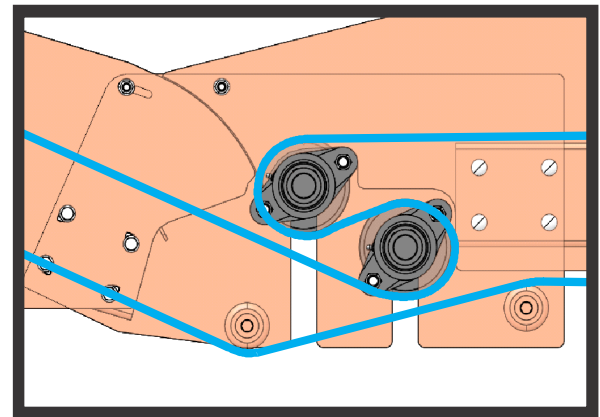

FIG. 3-17

1. Route the conveyor belt in a single loop around the top and bottom rollers.
2. Clamp both ends of the belt into a position where you can slide the connecting wire through the ends to lace it together.
3. Use the belt tensioner bolts and jam nuts at the end of the conveyor assembly to align and tension the belt as necessary.

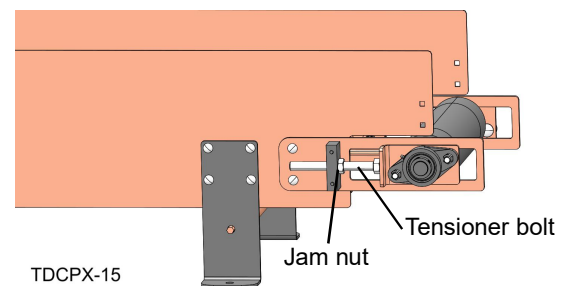

FIG. 3-18

3.5 Motor



WARNING! Have a certified electrician install the power to your machine.

Ensure the power supply cables are not a trip hazard.





CAUTION! Improper voltage will cause damage to the motors and electronic components.

Have a qualified electrician wire the motor to the supply power according to the instructions on the motor plate.

The electrical installation must meet local codes.

SECTION 4 MAINTENANCE

 **DANGER!** Lockout power supply before performing any service to the unit.

 **WARNING!** Secure all loose clothing, hair, and jewelry before servicing the equipment.

Wear proper safety equipment (eye, ear, hand, or foot) when performing service functions.

4.1 Daily Maintenance

Check the Rollers

1. Check the rollers every 8 hours of operation.
2. Remove any dirt or debris from the rollers.

Check Belt Wear

1. Check the conveyor belt for wear.
2. Replace a damaged or worn belt as needed.
3. Check the conveyor belt alignment after installing a new belt.

4.2 Every 200 Hours

Lubrication

Lubricate the roller bearings every 200 hours of operation with one to two pumps of high-quality lithium-based grease such as Shell Alvania No. 3. **Do not overgrease.**

4.3 Monthly Maintenance

Drive Chain Tension

1. Check and adjust the conveyor drive chain tension.
2. Remove the four mounting bolts securing the conveyor drive cover to the conveyor drive chain housing and remove the drive cover.
3. Loosen (do not remove) the four mounting bolts securing the gearbox to the gearbox mount bracket.
4. Move the gearbox/motor assembly until the center of the chain sags approximately 1/2" (12.7mm).

 **CAUTION!** Do not over-tension the conveyor drive chain. Damage to the gearbox will occur.

5. Retighten the gearbox mounting bolts.
6. Replace the drive cover to the drive chain housing.

Belt Alignment

1. Check and realign the conveyor belt if necessary.
2. Make sure the belt remains centered on the rollers while running.
3. Loosen the jam nut on one or both lower roller belt tensioner bolts.
4. Turn the tensioner bolts to tension or loosen the conveyor belt.
5. Tighten the jam nuts and start the drive motor to check if the conveyor belt still needs to be aligned.
6. Repeat the steps until the conveyor belt stays in place on the rollers while running.
7. Retighten the jam nuts when the belt alignment procedure is complete.

4.4 Quarterly Maintenance

Gearbox Oil

1. Check the gearbox oil level in the conveyor gearbox.
2. Add a synthetic gear oil such as Mobil Glygoyle 460 to the gearbox as needed to maintain the full level.

4.5 Bi-annual (6000 hrs) Maintenance

Change Gearbox Oil

1. Drain and refill the conveyor gearbox every 6000 hours or every 2 years of operation, whichever comes first.
2. Use 28 ounces (0.83L) of Mobil Glygoyle 460 oil to refill the gearbox.
3. Change oil each time maintenance requires gearbox disassembly.

Wood-Mizer offers replacement gear oil in 8 ounce (0.24L) bottles.

SECTION 5 REPLACEMENT PARTS

5.1 How To Use The Parts List

- Use the table of contents to locate the assembly that contains the part you need.
- Go to the appropriate section and locate the part in the illustration.
- Use the number pointing to the part to locate the correct part number and description in the table.
- Parts shown indented under another part are included with that part.
- Parts marked with a diamond (◆) are only available in the assembly listed above the part.

See the sample table below.

Sample Part #A01111 includes part F02222-2 and subassembly A03333.

Subassembly A03333 includes part S04444-4 and subassembly K05555.

The diamond (◆) indicates that S04444-4 is not available except in subassembly A03333.

Subassembly K05555 includes parts M06666 and F07777-77.



The diamond (◆) indicates M06666 is not available except in subassembly K05555.

REF	PART #	DESCRIPTION	COMMENTS	QTY.
	A01111	SAMPLE ASSEMBLY, COMPLETE (INCLUDES ALL INDENTED PARTS BELOW)		1
1	F02222-22	Sample Part		1
	A03333	Sample Subassembly (<i>Includes all indented parts below</i>)		1
2	S04444-4	Sample Part (◆ <i>Indicates part is only available with A03333</i>)	Available in assemblies only.	1
	K05555	Sample Subassembly (<i>Includes all indented parts below</i>)		1
3	M06666	Sample Part (◆ <i>Indicates part is only available with K05555</i>)	Available in assemblies only.	2
4	F07777-77	Sample Part		1

To Order Parts:

- Use your online Customer Gateway Account to find and order parts.
- From the continental U.S., call **1-800-525-8100** to order parts. Have your customer number, serial number (VIN when applicable), and part numbers ready when you call.
- From international locations, contact the Wood-Mizer distributor in your area for parts.

5.2 Torque Values

Grade		Units	SAE 5	SAE 8
Grade Mark				
Bolt Dia.	Threads. Per In.	Units	SAE 5	SAE 8
6	32	in-lbs (Nm)	20 (2.3)	-
8	32	in-lbs (Nm)	24 (2.7)	30 (3.4)
10	24	in-lbs (Nm)	35 (4.0)	45 (5.1)
10	32	in-lbs (Nm)	40 (4.5)	50 (5.7)
12	24	in-lbs (Nm)	50 (5.7)	65 (7.3)
1/4	20	in-lbs (Nm)	95 (10.7)	125 (14.1)
1/4	28	in-lbs (Nm)	95 (10.7)	150 (17.0)
5/16	18	ft-lbs (Nm)	17 (22.6)	23 (31.2)
5/16	24	ft-lbs (Nm)	20 (27.1)	25 (33.8)
3/8	16	ft-lbs (Nm)	30 (40.7)	40 (54.2)
3/8	24	ft-lbs (Nm)	35 (47.5)	45 (61.0)
7/16	14	ft-lbs (Nm)	50 (67.8)	65 (88.1)
7/16	20	ft-lbs (Nm)	55 (74.6)	70 (94.9)
1/2	13	ft-lbs (Nm)	75 (101.7)	100 (135.6)
1/2	20	ft-lbs (Nm)	85 (115.3)	110 (149.2)
9/16	12	ft-lbs (Nm)	105 (142.4)	135 (183.1)
9/16	18	ft-lbs (Nm)	115 (155.9)	150 (203.4)
5/8	11	ft-lbs (Nm)	150 (203.4)	195 (264.4)
5/8	18	ft-lbs (Nm)	160 (217.0)	210 (284.8)
3/4	10	ft-lbs (Nm)	170 (230.5)	220 (298.3)
3/4	16	ft-lbs (Nm)	175 (237.3)	225 (305.1)
7/8	9	ft-lbs (Nm)	302 (409.5)	473 (640.9)
7/8	14	ft-lbs (Nm)	300 (406.8)	400 (542.4)
1	8	ft-lbs (Nm)	466 (631.8)	714 (967.4)

5.3 Incline Conveyor, Drive Section

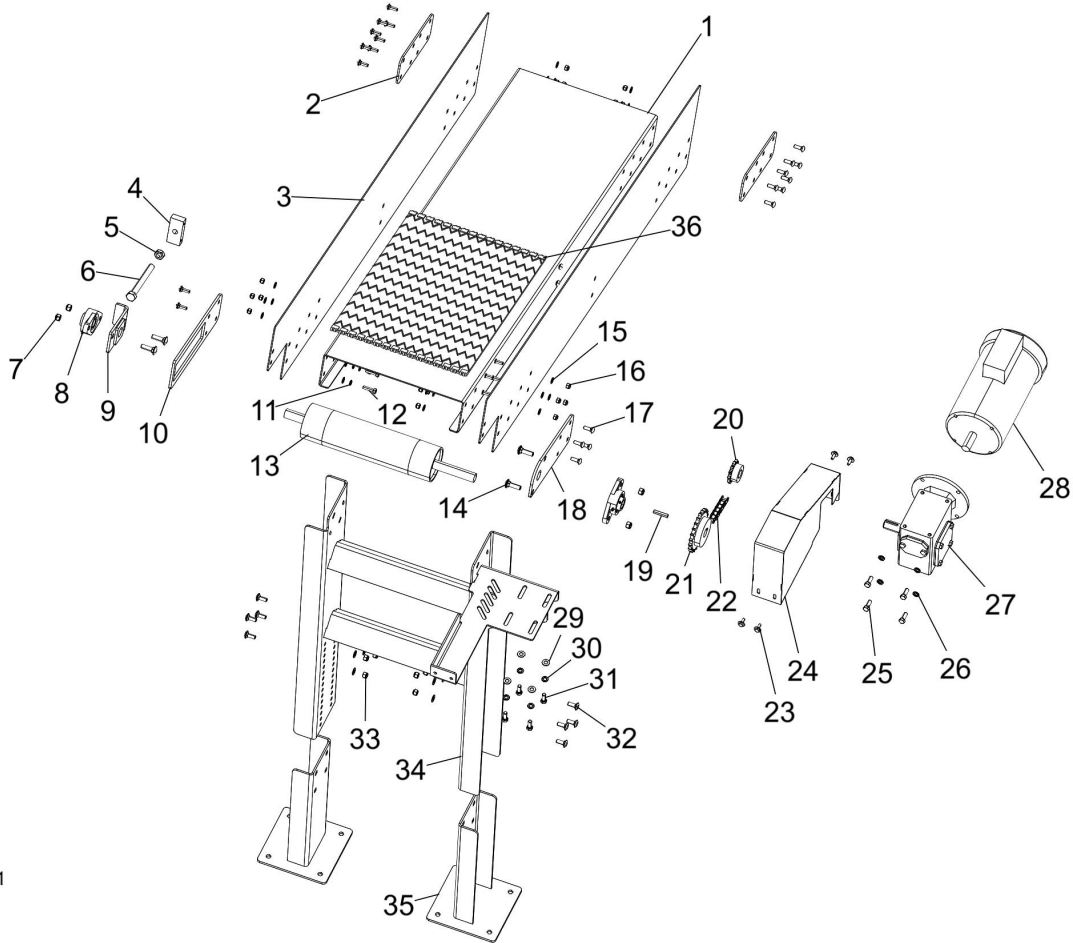

TD110323
TD110323_C_1

REF	PART #	DESCRIPTION	COMMENTS	QTY.
	110323	Conveyor Assy, PD200, Single		
1	101722	Channel, Flat Conveyor		1
2	101726	Plate, Conveyor Link		2
3	110155	Plate, Conveyor End 6"		2
4	101763	Block, Adjustment		1
5	F05010-11	Nut, 5/8-18 Hex Jam		1
6	F05009-148	Bolt, 5/8-18 X 6 HH FT ZN		1
7	F05010-135	Nut, 7/16-14 Nylock		4
8	038124	Bearing, 1 Flanged, VF2S 216		2
9	101758	Plate Wldmt, Conveyor Tensioner		1
10	101724	Plate, Conveyor Idler		1
11	F05011-13	Washer, 5/16 Split Lock		2
12	F05006-93	Bolt, 5/16-18x1-1/4 HH FT Gr5		2
13	130268	Pulley Wldmnt, 15" Driver	ECN: 38259.	1
14	F05007-229	Bolt, 7/16-14x1 1/2 Carriage		4
15	F05011-17	Washer, 5/16 SAE Flat		36
16	F05010-58	Nut, 5/16-18 Nyl Lock		34
17	F05006-90	Bolt, 5/16-18x1 Carriage		34

5 Replacement Parts

Incline Conveyor, Drive Section

REF	PART #	DESCRIPTION	COMMENTS	QTY.
18	101723	Plate, Conveyor Drive		1
19	042810	Key, 1/4Sqx1 5/8		1
20	102624	Sprocket, #50 x 12 Tooth 1" Bore		1
21	003941	Sprocket, 50B23x1		1
22	054484	Chain, #50x28 3/4		1
23	F05005-134	Bolt, 1/4-20x3/4 W/Conical Washer		4
24	110299	Cover Wldmnt, PD Conveyor		1
	036239	Assy, Motor/Gearbox, 2HP 1Ph 10:1		1
25	F05007-87	Bolt, 3/8-16x1 Gr5 HH		4
26	F05011-4	Washer, 3/8 Split Lock		4
27	016763	Gear Reducer, 10:1, 2hp		1
28	038655	Motor, 2HP 1Ph 1740RPM		1
	079196	Motor, 2HP 3P 240/480 145TC Premium Eff		1
29	F05011-3	Washer, 3/8 Flat SAE		12
30	F05011-4	Washer, 3/8 Split Lock		4
31	F05007-87	Bolt, 3/8-16x1 Gr5 HH		4
32	F05007-165	Bolt, 3/8-16x1 Carriage, Zinc Gr 5		8
33	F05010-10	Nut, 3/8-16 Hex Nyl Lock		8
34	110163	Leg Wldmnt, IC, Front		1
35	110164	Foot Wldmnt, IC		2
36	130143-553	Belt, 15 3/4" x 553" Z-Top W/Gator Lace (10ft)		1
	130143-671	Belt, 15 3/4" X 671" Z-top W/Gator Lace (15ft)		1
	130143-789	Belt, 15 3/4" X 789" Z-top W/Gator Lace (20ft)		1
	130143-907	Belt, 15 3/4" X 907" Z-top W/Gator Lace (25ft)		1
	130143-1025	Belt, 15 3/4" X 1025" Z-top W/Gator Lace (30ft)		1
	130143-1143	Belt, 15 3/4" X 1143" Z-top W/Gator Lace (35ft)		1
	130143-1261	Belt, 15 3/4" X 1261" Z-top W/Gator Lace (40ft)		1
	130143-1379	Belt, 15 3/4" X 1379" Z-top W/Gator Lace (45ft)		1

5.4 Incline Support Frame

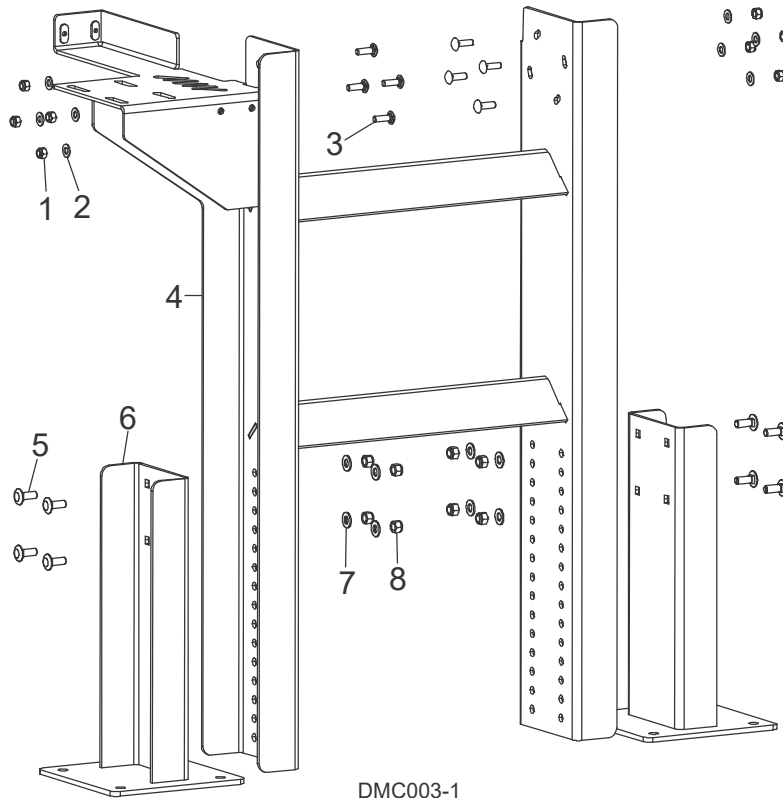

REF	PART #	DESCRIPTION	COMMENTS	QTY.
1	F05010-58	Nut, 5/16-18 Nyl Lock		8
2	F05011-17	Washer, 5/16 SAE Flat		8
3	F05006-90	Bolt, 5/16-18x1 Carriage		8
4	110163	Leg Weldment, IC, Front		1
5	F05007-165	Bolt, 3/8-16x1 Carriage, Zinc Gr 5		8
6	110164	Foot Weldment, IC		2
7	F05011-3	Washer, 3/8 Flat SAE		8
8	F05010-10	Nut, 3/8-16 Hex Nyl Lock		8

5.5 Conveyor Middle Section

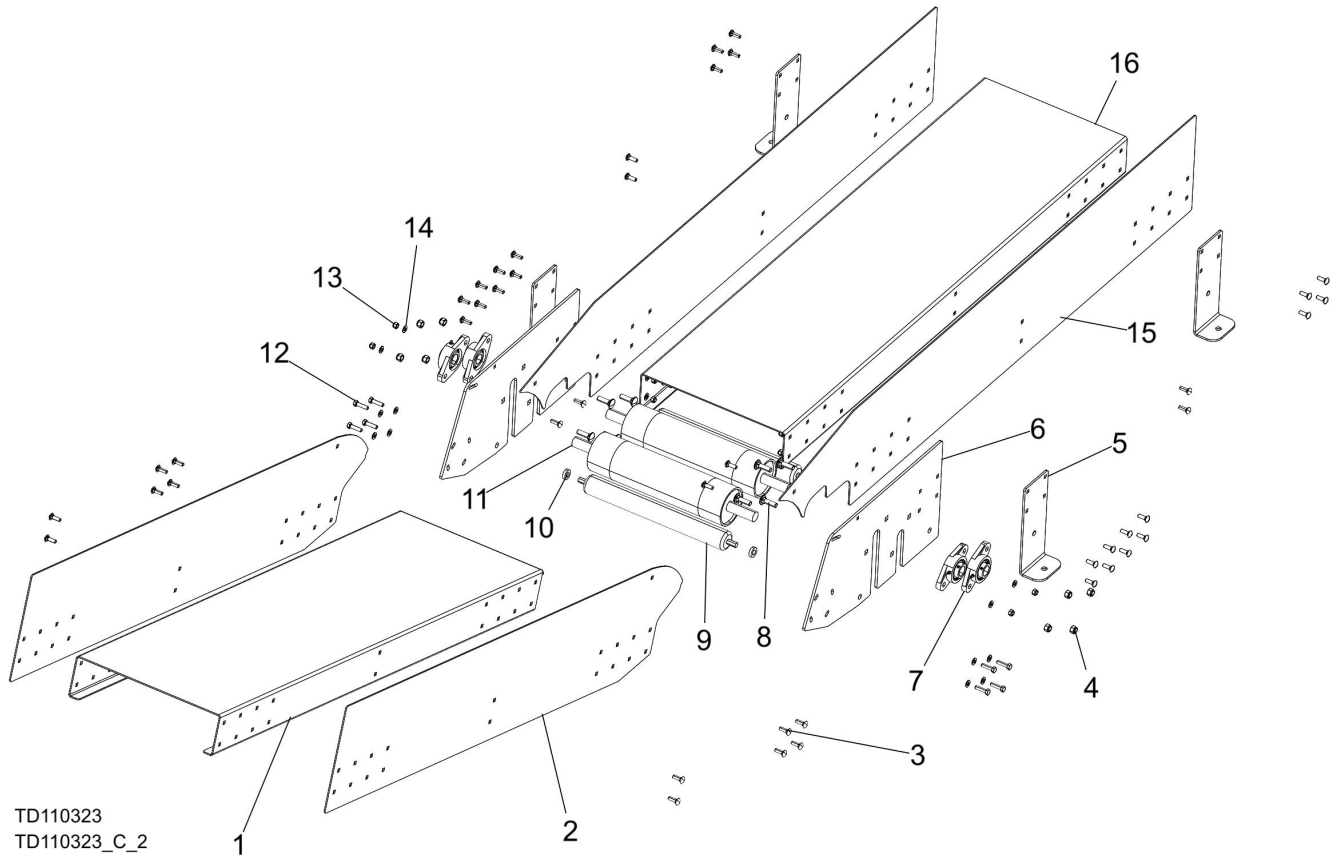

REF	PART #	DESCRIPTION	COMMENTS	QTY.
	110323	Conveyor Assy, PD200, Single, Single ph		
1	065524	Channel, Flat Conveyor W/Tab		1
2	110154	Plate, Conveyor Side Post-Transition		2
3	F05006-90	Bolt, 5/16-18x1 Carriage		40
4	F05010-135	Nut, 7/16-14 Nylock		8
5	101725	Leg, Conveyor		4
6	102743	Plate, Incline Bolt		2
7	038124	Bearing, 1 Flanged, VF2S 216		4
8	F05007-229	Bolt, 7/16-14x1 1/2 Carriage		8
9	051399	Roller, 1.90 ODx15.75		3
10	074405	Spacer, .52IDx1.00ODx.25		6
11	130298	Pulley Wldmnt, 15" Driven	ECN: 38259.	2
12	F05006-93	Bolt, 5/16-18x1-1/4 HH FT Gr5		8
13	F05010-58	Nut, 5/16-18 Nyl Lock		48
14	F05011-17	Washer, 5/16 SAE Flat		56
15	110153	Plate, Conveyor Side Pre-Transition		2
16	101722	Channel, Flat Conveyor		1

5.6 Middle Sections

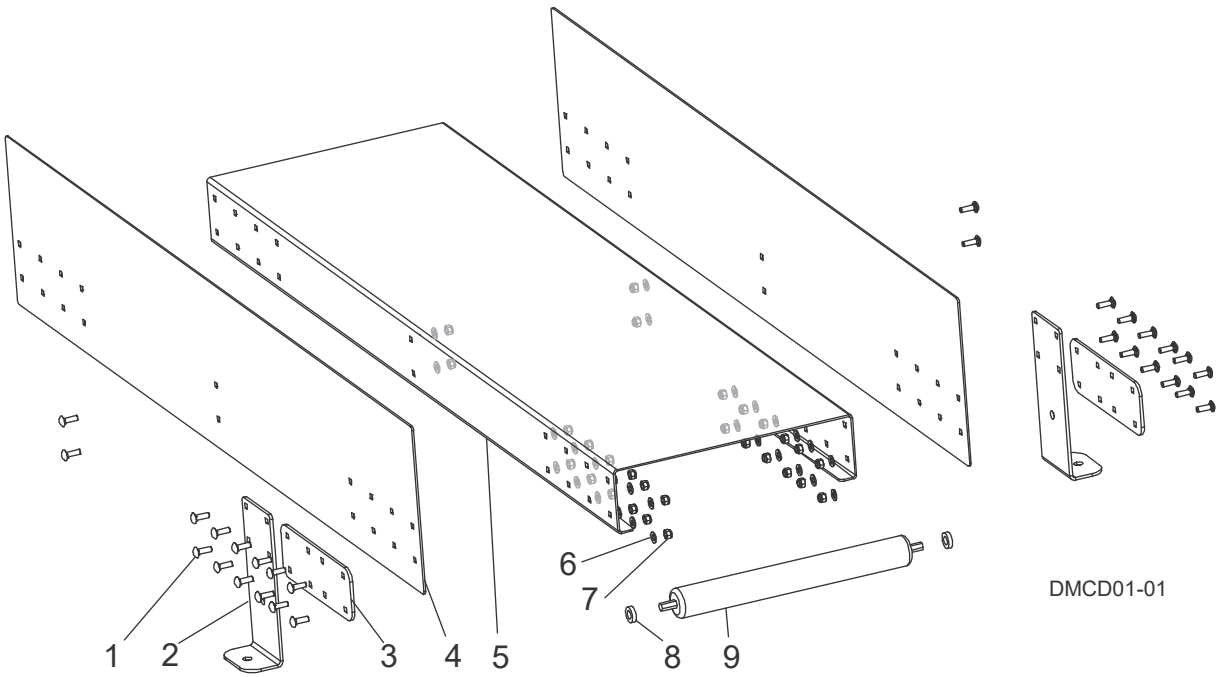

REF	PART #	DESCRIPTION	COMMENTS	QTY.
1	F05006-90	Bolt, 5/16-18x1 Carriage		28
2	101725	Leg, Conveyor		2
3	101726	Plate, Conveyor Link		2
4	110382	Plate, Conveyor Side Left		2
5	101722	Channel, Flat Conveyor		1
6	F05011-17	Washer, 5/16 SAE Flat		28
7	F05010-58	Nut, 5/16-18 Nyl Lock		28
8	074405	Spacer, .52IDx1.00ODx.25		2
9	051399	Roller, 1.90 ODx15.75		1

5.7 Tail Section

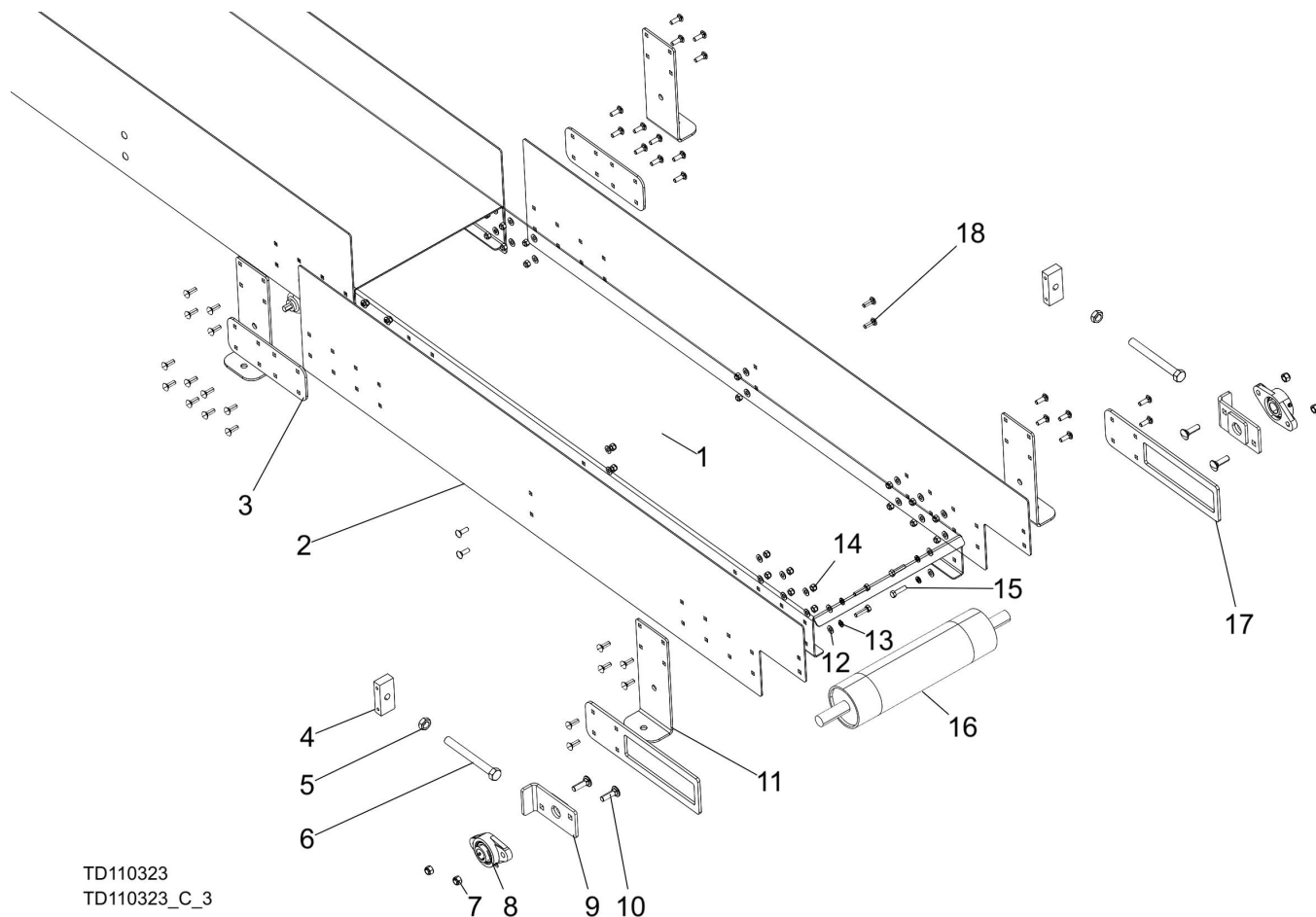

REF	PART #	DESCRIPTION	COMMENTS	QTY.
10	110323	Conveyor Assy, PD200, Single, Single ph		
1	065524	Channel, Flat Conveyor W/Tab		1
2	110155	Plate, Conveyor End 6"		2
3	101726	Plate, Conveyor Link		2
4	101763	Block, Adjustment		2
5	F05010-11	Nut, 5/8-18 Hex Jam		2
6	F05009-148	Bolt, 5/8-18 X 6 HH FT ZN		2
7	F05010-135	Nut, 7/16-14 Nylock		4
8	038124	Bearing, 1 Flanged, VF2S 216		2
9	101758	Plate Wldmt, Conveyor Tensioner		2
10	F05007-229	Bolt, 7/16-14x1 1/2 Carriage		4
11	101725	Leg, Conveyor		2
12	F05011-17	Washer, 5/16 SAE Flat		36
13	F05011-13	Washer, 5/16 Split Lock		4
14	F05010-58	Nut, 5/16-18 Nyl Lock		32
15	F05006-93	Bolt, 5/16-18x1-1/4 HH FT Gr5		4
16	130298	Pulley Wldmnt, 15" Driven	ECN: 38259.	1
17	101724	Plate, Conveyor Idler		2
18	F05006-90	Bolt, 5/16-18x1 Carriage		32

SECTION 6 SETUP

6.1 Contents Of The Parts Bags

Verify the content of each to ensure that all necessary parts are included.

PART	DESCRIPTION	QTY.	PART	DESCRIPTION	QTY.
118301	Assy, Horiz Sec; Mod; 15-3/4" Belt Con	1	118300	Assy, Horiz Sec; Tail; 15-3/4" Belt Con	1
133059	Kit, CPS Mid Section Bolts	1	133058	Kit, CPS Tail Section Bolts	1
118303	Assy, Incline; 15 3/4" Belt Conveyor	1			
133060	Kit, CPS Incline Section Bolts	1			

133059		Kit, CPS Mid Section Bolts				1
F05006-90	Bolt, 5/16-18x1 Carriage Gr5	28	F05011-17	Washer, 5/16 SAE Flat	28	
F05010-58	Nut, 5/16-18 Nylok Hex	28	F05010-220			

133060		Kit, CPI Mid Section Bolts				1
F05005-134	Bolt, 1/4-20x3/4 HH w/Conical Washer	4	F05010-58	Nut, 5/16-18 Nylok Hex	18	
F05006-90	Bolt, 5/16-18x1 Carriage Gr5	10	F05011-17	Washer, 5/16 SAE Flat	26	
F05006-93	Bolt, 5/16-18x1 1/4 HH FT Gr5	8				

133058		Kit, CPS Tail Section Bolts				1
F05006-90	Bolt, 5/16-18x1 Carriage Gr5	40	F05010-135	Nut, 7/16-14 Nylock	4	
F05006-93	Bolt, 5/16-18x1 1/4 HH FT Gr5	4	F05010-58	Nut, 5/16-18 Nylok Hex	40	
F05007-229	Bolt, 7/16-14x1 1/2 Carriage	4	F05011-11	Washer, 1/4 SAE Flat	4	
F05009-148	Screw, 3/8-16x3 SHC	2	F05011-13	Washer, 5/16 Split Loc	44	
F05010-11	Nut, 5/8-18 Hex Jam	2				





6.2 Part Quantity Per Conveyor Size

Install the correct number/length of parts required for a particular conveyor size, specified in the table below, to ensure proper operation, maintenance and safety of the conveyor system.

Standardized conveyor size		10	15	20	25	30	35	40	45
051399	Roller, 1.90 ODx15.75	4	5	6	7	8	9	10	11
074405	Spacer, .52IDx1.00 ODx.25	8	10	12	14	16	18	20	22
101722	Channel, Flat Conveyor	2	3	4	5	6	7	8	9
101725	Leg, Conveyor	6	8	10	12	14	16	18	20
101726	Plate, Conveyor Link	6	8	10	12	14	16	18	20
110382	Plate, Conveyor Side Left	0	2	4	6	8	10	12	14
133059	Kit, CPS Mid Section Bolts	0	1	2	3	4	5	6	7
130143	Belt [length in inches as a suffix]	-553	-671	-789	-907	-1025	-1143	-1261	-1379

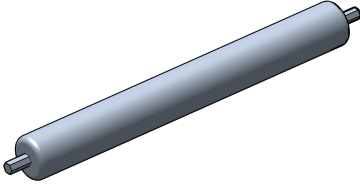
6.3 Remove and Inspect The Parts Boxes

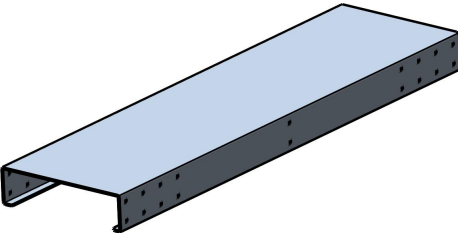
Part #	Description	Qty	Part #	Description	Qty
M2346	Manual, Pallet Dismantler Conveyor	1	133058	Kit, CPS Tail Section Bolts	1
015882	Skid, LT15 Shipping, 45x86.5	1	133060	Kit, CP Incline Section Bolts	1
133059	Kit, CPS Mid Section Bolts	0			

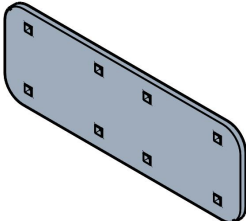
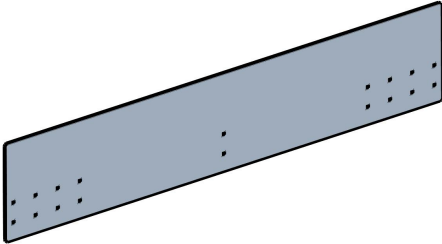
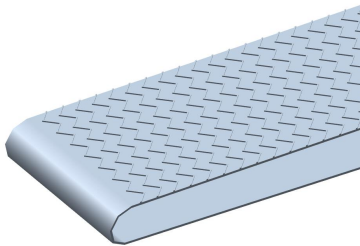
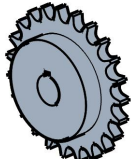

Part #	Description	Qty	Part #	Description	Qty
051399	Roller, 1.90 ODx15.75	4	074405	Spacer, .52IDx1.00 ODx.25	8
					
101722	Channel, Flat Conveyor	2	101725	Leg, Conveyor	6
					
101726	Plate, Conveyor Link	6	110382	Plate, Conveyor Side Left	0
					
130143	Belt	1	003941	Sprocket, 50B23x1	1
					

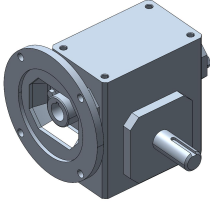
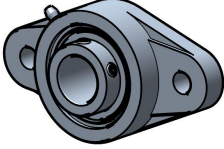
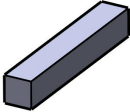
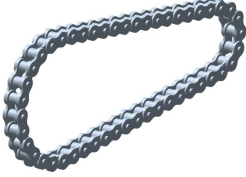
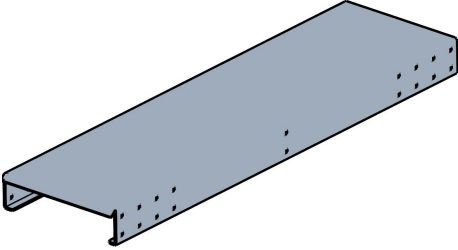
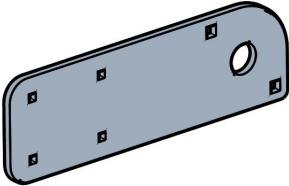
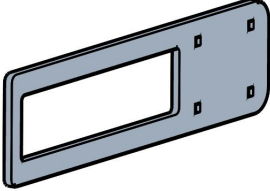
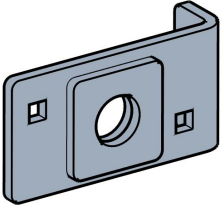
6 Setup
Remove and Inspect The Parts Boxes

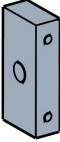
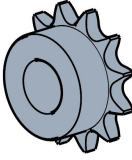
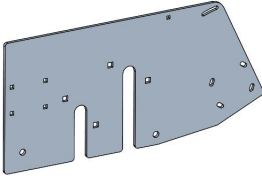
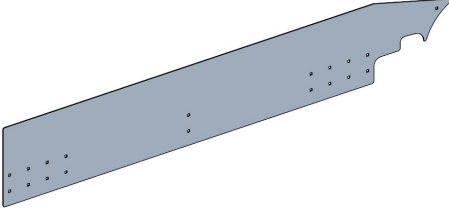
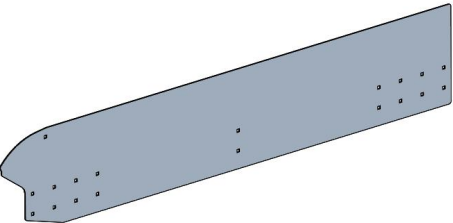
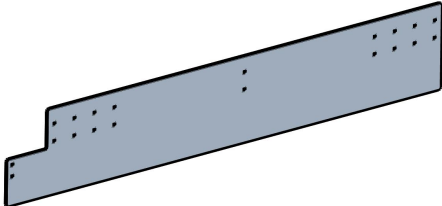
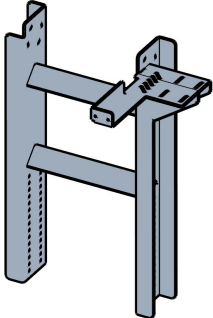
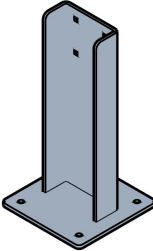
Part #	Description	Qty	Part #	Description	Qty
016763	Gear Reducer, 10:1, 2hp	1	038124	Bearing, 1 Flanged, VF2S 216	8
					
042810	Key, 1/4Sqx1 5/8	1	054484	Chain, #50x28 3/4	1
					
065524	Channel, Flat Conveyor W/Tab	2	101723	Plate, Conveyor Drive	1
					
101724	Plate, Conveyor Idler	3	101758	Plate Widmt, Conveyor Tensioner	3
					

Part #	Description	Qty	Part #	Description	Qty
101763	Block, Adjustment	3	102624	Sprocket, #50 x 12 Tooth 1" Bore	1
					
102743	Plate, Incline Bolt	2	110153	Plate, Conveyor Side Pre-Transition	2
					
110154	Plate, Conveyor Side Post-Transitio	2	110155	Plate, Conveyor End 6"	4
					
110163	Leg Widmnt, IC, Front	1	110164	Foot Widmnt, IC	2
					

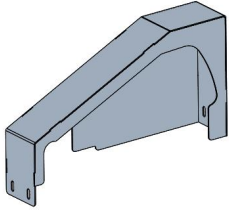
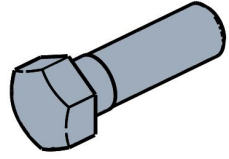
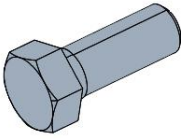
6 Setup
Remove and Inspect The Parts Boxes

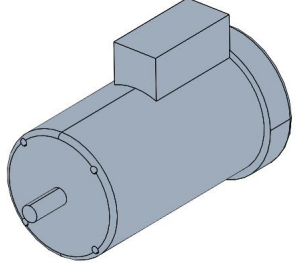
Part #	Description	Qty	Part #	Description	Qty
110299	Cover Widmnt, PD Conveyor	1	F05007-123	Bolt, 3/8-16x1 1/4 FT HH Gr5	4
					
F05007-87	Bolt, 3/8-16x1 HH Gr5	4	F05011-3	Washer, 3/8 Flat SAE	4
					
F05011-4	Washer, 3/8 Split Lock	8	038655	Motor, 2HP 3P 230/460 145TC Premium Eff	1
					
079196	Motor, 2HP 3P 230/460 145TC Premium Eff	1	016763	Gear Reducer, 10:1, 2hp	1
	