

# Wood-Mizer® Resaw

## Parts Manual

---

HR1000 Resaw

Rev. A2.06

---

**Safety is our #1 concern!**

*Form #1688*



**WARNING! Read and understand this manual before using this machine.**

**SECTION 1 REPLACEMENT PARTS**

1.1 How To Use The Parts List .....1-2  
     *To Order Parts* ..... 1-2  
 1.2 Sample Assembly .....1-3  
 1.3 Torque Values .....1-4

**SECTION 2**

**SECTION 3 SAW HEAD PARTS**

2.1 Blade Tensioner Assembly .....2-1  
 2.2 Tension Release Handle Assembly .....2-3  
 2.3 Saw Head Mount Assembly .....2-4  
 2.4 Saw Motor Assembly .....2-5  
 2.5 Inner Blade Guide Assembly.....2-6  
 2.6 Outer Blade Guide Assembly .....2-9  
 2.7 Up/Down Assembly .....2-12  
 2.8 Blade Wheel Assembly (Drive Side) .....2-14  
 2.9 Blade Wheel Assembly (Idle Side) .....2-16  
 2.10 Blade Housing Cover .....2-17  
 2.11 Sawdust Chute .....2-18  
 2.12 Saw Head Decals .....2-19

**SECTION 4 FEED TRACK/FRAME PARTS**

3.1 Hydraulic Blade Tensioner Assembly .....3-1  
 3.2 Perimeter Fence Assembly .....3-2  
 3.3 Feed Track Assembly .....3-5  
 3.4 Feed Track Nylon Pads .....3-7  
 3.5 Feed Roller Assembly (Non-Air) .....3-8  
 3.6 Feed Roller Assembly (Air-Lift) .....3-10  
 3.7 Hydraulic Tank Assembly .....3-12  
 3.8 Hydraulic Valve Assembly (2 and 4-Head) .....3-14  
 3.9 Hydraulic Valve Assembly (6-Head) .....3-15  
 3.10 Crowder Fence Assembly .....3-16  
 3.11 Control Box Decals .....3-17  
 3.12 Parts Kit .....3-18

## SECTION 1 REPLACEMENT PARTS



## Replacement Parts

### *How To Use The Parts List*

---

#### 1.1 How To Use The Parts List

- Use the table of contents to locate the assembly that contains the part you need.
- Go to the appropriate section and locate the part in the illustration.
- Use the number pointing to the part to locate the correct part number and description in the table.
- Parts shown indented under another part are included with that part.

#### *To Order Parts*

- From the continental US, call **1-800-525-8100** to order parts. Have your customer number, vehicle identification number, and part numbers ready when you call.
- From other international locations, contact the Wood-Mizer distributor in your area for parts.

## 1.2 Sample Assembly

REF	PART #	DESCRIPTION (Indicates Part Available Assemblies Only)	COMMENTS	QTY.
	012345	SAMPLE ASSEMBLY, COMPLETE	INCLUDES ITEMS 1-6	1
1	F02222-22	Sample Part		1
2	F03333-33	Sample Part		2
	098765	Sample Subassembly	Includes items 3-6	1
3	S04444-44	Subassembly Sample Part		1
4	K55555	Subassembly Sample Part		1
	054321	Sample Sub-Subassembly	Includes items 5-6	2
5	022222	Sub-Subassembly Sample Part		1
6	F10234-56	Sub-Subassembly Sample Part		1

The Sample Assembly, Complete, part number 02345 (top level assembly) includes two parts (F0222-22 and F0333-33) and the 098765 subassembly.



Subassembly 098765 contains two parts(S04444-44 and K55555) and two copies of sub-subassembly 054321.

Each sub-subassembly 054321 contains two parts (022222 and F10234-56).

# 1 Replacement Parts

## Torque Values

### 1.3 Torque Values

Grade		Units	SAE 5	SAE 8
Grade Mark				
Bolt Dia.	Threads. Per In.	Units	SAE 5	SAE 8
6	32	in-lbs (Nm)	20 (2.3)	-
8	32	in-lbs (Nm)	24 (2.7)	30 (3.4)
10	24	in-lbs (Nm)	35 (4.0)	45 (5.1)
10	32	in-lbs (Nm)	40 (4.5)	50 (5.7)
12	24	in-lbs (Nm)	50 (5.7)	65 (7.3)
1/4	20	in-lbs (Nm)	95 (10.7)	125 (14.1)
1/4	28	in-lbs (Nm)	95 (10.7)	150 (17.0)
5/16	18	ft-lbs (Nm)	17 (22.6)	23 (31.2)
5/16	24	ft-lbs (Nm)	20 (27.1)	25 (33.8)
3/8	16	ft-lbs (Nm)	30 (40.7)	40 (54.2)
3/8	24	ft-lbs (Nm)	35 (47.5)	45 (61.0)
7/16	14	ft-lbs (Nm)	50 (67.8)	65 (88.1)
7/16	20	ft-lbs (Nm)	55 (74.6)	70 (94.9)
1/2	13	ft-lbs (Nm)	75 (101.7)	100 (135.6)
1/2	20	ft-lbs (Nm)	85 (115.3)	110 (149.2)
9/16	12	ft-lbs (Nm)	105 (142.4)	135 (183.1)
9/16	18	ft-lbs (Nm)	115 (155.9)	150 (203.4)
5/8	11	ft-lbs (Nm)	150 (203.4)	195 (264.4)
5/8	18	ft-lbs (Nm)	160 (217.0)	210 (284.8)
3/4	10	ft-lbs (Nm)	170 (230.5)	220 (298.3)
3/4	16	ft-lbs (Nm)	175 (237.3)	225 (305.1)
7/8	9	ft-lbs (Nm)	302 (409.5)	473 (640.9)
7/8	14	ft-lbs (Nm)	300 (406.8)	400 (542.4)
1	8	ft-lbs (Nm)	466 (631.8)	714 (967.4)



COARSE THREAD					FINE THREAD					Wrench Size
Diameter & Thread Pitch	Metric 8.8		Metric 10.9		Diameter & Thread Pitch	Metric 8.8		Metric 10.9		
	N-m	lbs-ft	N-m	lbs-ft		N-m	lbs-ft	N-m	lbs-ft	
6 x 1.0	8	6	11	8						10 mm
8 x 1.25	20	15	27	20	8 x 1.0	21	16	29	22	13 mm
10 x 1.5	39	29	54	40	10 x 1.25	41	30	57	42	16 mm
12 x 1.75	68	50	94	70	12 x 1.25	75	55	103	76	18 mm
14 x 2.0	109	80	151	111	14 x 1.5	118	87	163	120	21 mm
16 x 2.0	169	125	234	173	16 x 1.5	181	133	250	184	24 mm
18 x 2.5	234	172	323	239	18 x 1.5	263	194	363	268	27 mm
20 x 2.5	330	244	457	337	20 x 1.5	367	270	507	374	30 mm
22 x 2.5	451	332	623	460	22 x 1.5	495	365	684	505	34 mm
24 x 3.0	571	421	790	583	24 x 2.0	623	459	861	635	36 mm
30 x 3.0	1175	867	1626	1199	30 x 2.0	1258	928	1740	1283	46 mm

**SECTION 1**

## SECTION 2 SAW HEAD PARTS

### 2.1 Blade Tensioner Assembly

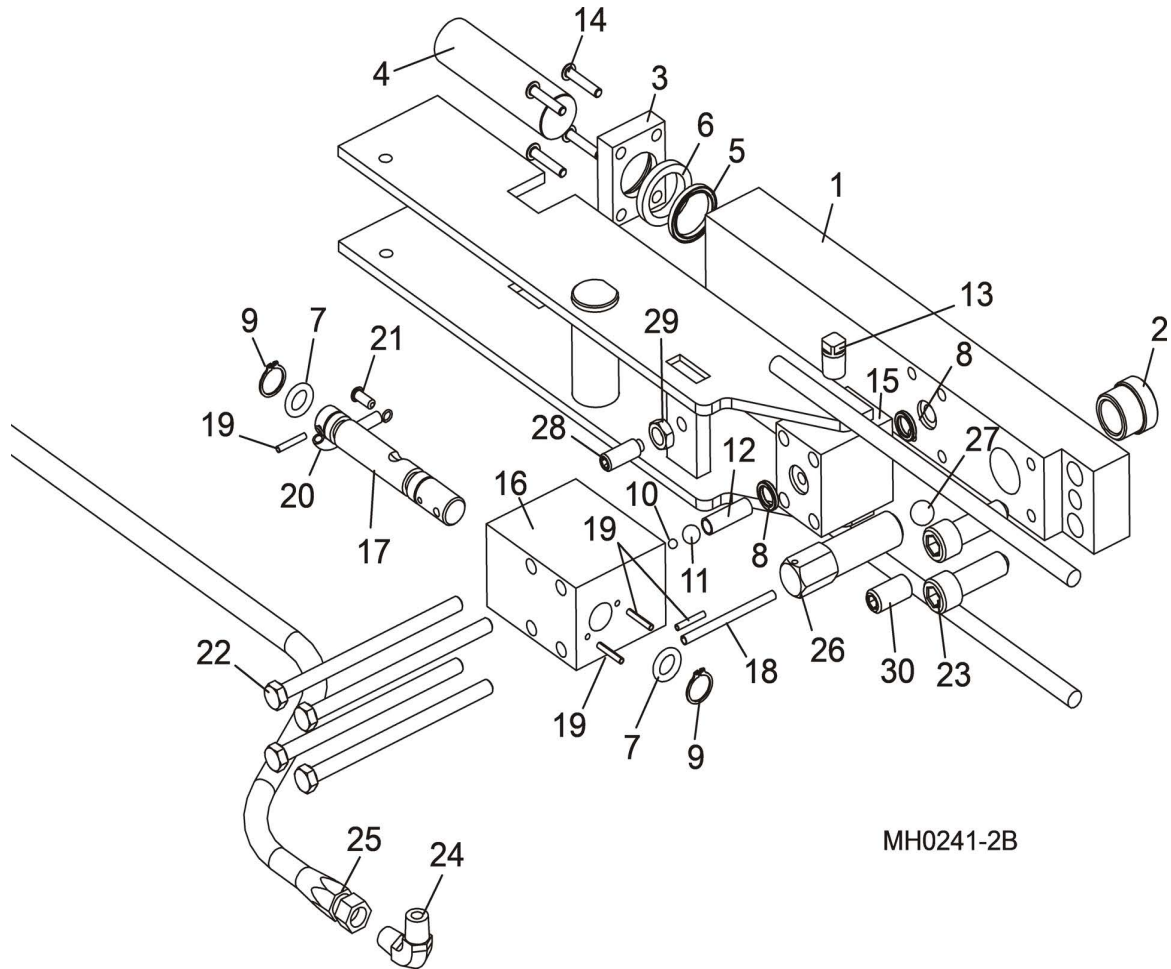

MH0241-2B

REF	PART #	DESCRIPTION	COMMENTS	QTY.
	A22220	<b>TENSIONER ASSEMBLY, MULTIHEAD BLADE</b>		1*
1	022221	Bar, Blade Tensioner	Bushing S22786 is welded to tensioner block S11054. Factory removal and installation recommended. Use 022221 Tensioner Block w/Bushing for field service.	1
2	S22786	Bushing, 3/4-32 Threaded		1
3	S10089	Block, Tensioner Seal		1
4	S10059	Piston, Blade Tensioner		1
	A22910	Seal Kit, Hydraulic Tensioner		1
5	P10051	Seal, 1" Diameter Tensioner		1
6	P10053	Wiper, 1" Diameter Tensioner		1
7	P09685	O-Ring, Tensioner Valve Spool		2
8	P10377	O-Ring, 5/8" x 3/32" Square		2
9	F04254-2	Ring, 5/8" Retainer		2
10	P09744	Ball, 3/16" Diameter Steel		1
11	P09133	Ball, 3/8" Diameter Steel		1
12	P22041	Spring, LC-038E-15SS		1
13	P05498	Plug, 1/4" NPT Pipe		1



REF	PART #	DESCRIPTION	COMMENTS	QTY.
14	F05004-43	Bolt, #10-24 Socket Button Head		4
15	S22213	Block, Tensioner Valve Mount		1
16	S22216	Block, Tensioner Valve		1
17	S22326	Spool, Tensioner Valve		1
18	F05012-27	Pin, 3/16" x 2 1/2" Roll		1
19	F05012-6	Pin, 1/8" x 3/4" Roll		4
20	P10064	Spring, LE-041C-7MW		1
21	F05015-25	Screw, #7 x 1/2" Drive		1
22	F05006-52	Bolt, 5/16-18 x 5" Hex Head Grade 8		4
23	F05008-44	<b>BOLT, 1/2-20 X 1 1/2" SOCKET HEAD</b>		2
24	P09140	<b>FITTING, 1/4" NPT 90° ELBOW</b>		1*
25	P22299	<b>HOSE, 1/4" DIA. X 78" HYDRAULIC W/FITTINGS</b>		1*
	007652	<b>SCREW ASSEMBLY, BLADE WHEEL TILT</b>		1*
26	007651	Screw, Cant Adjustment	Available in assemblies only.	1
27	P02720	Ball, 1/2" Diameter Detent		1
28	F05007-88	<b>SCREW, 3/8-16 X 1" SOCKET HEAD BRASS TIP</b>		1*
29	F05010-29	<b>NUT, 3/8-16 HEX JAM</b>		1*
30	F05008-9	<b>SCREW, 1/2-13 X 1" OVAL POINT SET NYLON LOCK</b>		1

## 2.2 Tension Release Handle Assembly

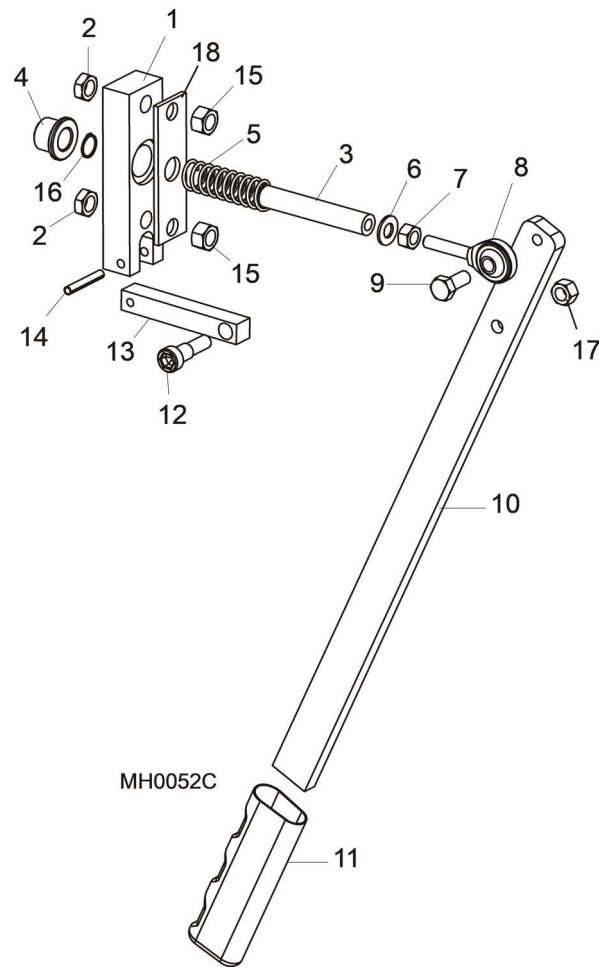

REF	PART #	DESCRIPTION	COMMENTS	QTY.
	A22528	<b>HANDLE ASSEMBLY, TENSION RELEASE</b>		1*
1	S22527	Plate, Tensioner Stop		1
2	F05010-29	Nut, 3/8-16 Hex Jam		2
3	S22526	Rod, Tensioner Push		1
4	P22662	Bushing, Flanged Bronze		1
5	P05155	Spring, LC-072J-7MW		1
6	F05011-17	Washer, 5/16" SAE Flat		1
7	F05010-28	Nut, 5/16-24 Hex		1
8	P09814	Rod End, 5/16-24 Male		1
9	F05006-5	Bolt, 5/16-18 x 3/4" Hex Head		1
10	S22524	Handle, Tension Release		1
11	P04731	Grip, Tension Release Handle		1
12	F05006-56	Bolt, 3/8" x 1/2" Shoulder		1
13	S22525	Bar, Tension Release Handle Link		1
14	F05012-16	Pin, 3/16" x 1 1/4" Roll		1
15	F05010-25	Nut, 3/8-16 Hex Lock		2
16	F04254-18	Ring, 1/2" Retainer		1
17	F05010-6	Nut, 5/16-18 Hex Lock		1
18	036600	Plate, Bushing Retainer		1

## 2.3 Saw Head Mount Assembly

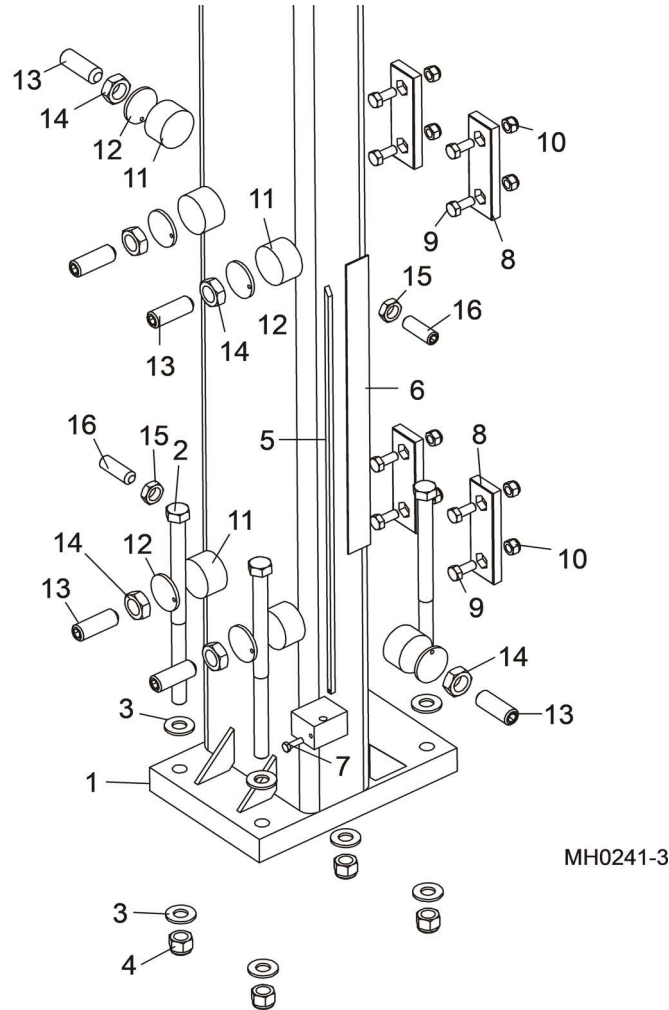

REF	PART #	DESCRIPTION	COMMENTS	QTY.
1	007682	TUBE WELDMENT, SAWHEAD MOUNT		1*
2	F05008-69	BOLT, 1/2-13 X 8" HEX HEAD GRADE 5		4*
3	F05011-2	WASHER, 1/2" SAE FLAT		8*
4	F05010-8	NUT, 1/2-13 NYLON LOCK		4*
5	S22636	POINTER, MULTIHEAD BLADE HEIGHT		1*
6	S22300	DECAL, MULTIHEAD HEIGHT SCALE (INCH)		1*
	S22301	DECAL, MULTIHEAD HEIGHT SCALE (METRIC)		1*
7	F05004-18	BOLT, #10-24 X 5/8" HEX HEAD		1*
8	M04096	PAD, UP/DOWN DELRIN		4*
9	F05006-5	BOLT, 5/16-18 X 3/4" HEX HEAD		8*
10	F05010-58	NUT, 5/16-18 HEX NYLON LOCK		8*
11	S22561	PAD, UP/DOWN ADJUSTABLE NYLON		6*
12	042432	PAD, NYLON BACKING		6*
13	F05009-27	SCREW, 5/8-18 X 1 1/4" SOCKET HEAD FLAT POINT SET		6*
14	F05010-11	NUT, 5/8-18 HEX JAM		6*
15	F05010-31	NUT, 1/2-13 HEX JAM		28
16	F05008-31	SCREW, 1/2-13 X 1 1/2" SOCKET HEAD FLAT POINT SET		2*

## 2.4 Saw Motor Assembly

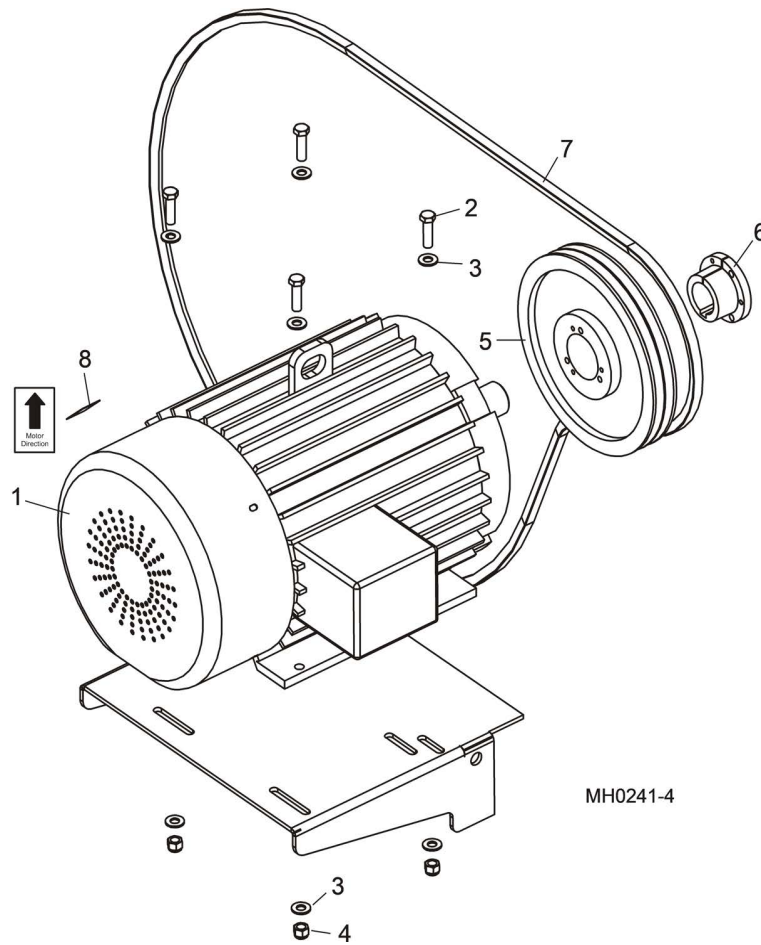

REF	PART #	DESCRIPTION	COMMENTS	QTY.
1	130056	MOTOR, 25HP 1800RPM MARATHON PREMIUM EFF		1*
2	F05008-74	BOLT, 1/2-13X2 1/2 HH GR5		4*
3	F05011-2	WASHER, 1/2" SAE FLAT		8*
4	F05010-8	NUT, 1/2" NYLON LOCK		4*
5	007722	PULLEY, 2/5V X 11.8 SK		1*
6	P21000	BUSHING, SK 1 7/8"		1*
7	128300	BELT, 5VFL1320		1*
8	S20097	DECAL, MOTOR DIRECTION		1*

## 2.5 Inner Blade Guide Assembly

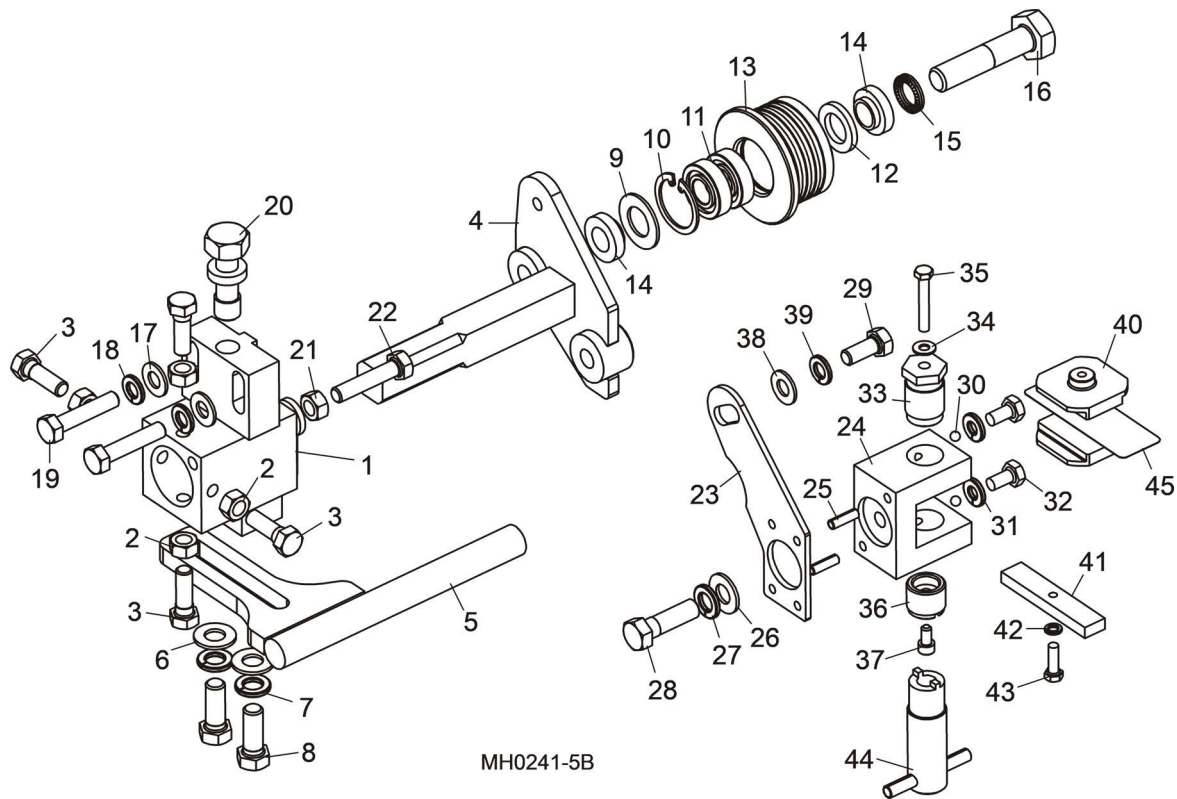

MH0241-5B

REF	PART #	DESCRIPTION	COMMENTS	QTY.
	007732	<b>GUIDE ASSEMBLY, HR1000 INNER BLADE</b>		1
	007733	Block Assembly, HR1000 Inner Blade Guide Mount		1*
<b>1</b>	007729	Block Weldment, HR1000 Blade Guide Mount		1
<b>2</b>	F05010-17	Nut, 5/16-18 Hex		4
<b>3</b>	F05006-88	Bolt, 5/16-18 x 1" Hex Head Stainless Steel		4
<b>4</b>	003913	Bracket Weldment, Inner Blade Guide Mount		1
<b>5</b>	007731	Deflector Weldment, HR1000 Inner Blade Guide		1
<b>6</b>	F05011-3	Washer, 3/8" SAE Flat		2
<b>7</b>	F05011-4	Washer, 3/8" Split Lock		2
<b>8</b>	F05007-87	Bolt, 3/8-16 x 1" Hex Head Grade 5		2
	A04925	Roller Assembly, Blade Guide (standard for use with 1 1/4" & 1 1/2" blades)	The resaw is equipped standard with blade guide rollers that can be used with the standard 1 1/4" blade or 1 1/2" blades. Optional extended blade guide rollers are available for use with 1 1/2" blades. The extended rollers may provide more stability during difficult sawing, but will reduce the total amount of times the blade can be reused after sharpening. Use kit 006382 to convert the rollers and guide blocks for both blade guides for 1 1/2" blades.	1
	014299	Roller Assembly, Extended Blade Guide (optional for use with 1 1/2" blades)		1
	K07079	Bearing Kit, Blade Guide Rebuild		1

REF	PART #	DESCRIPTION	COMMENTS	QTY.
9	P04252	Washer, 5/8" White Felt		1
10	F04254-1	Ring, 1 1/8" Interior Retaining		1
11	015975	Bearing, R8-2RS Blade Guide	Available in assemblies only.	2
12	P06455	Washer, 5/8" Gray Felt		1
	F05005-105	Screw, 1/4-28 x 1/4" Socket Head Cup Point Set Black Oxide		1
	057407-1507	Instruction Sheet, Blade Guide Rebuild		1
13	S04250	Roller, Flanged Blade Guide (1 1/4" & 1 1/2" blade)	Available in assemblies only.	1
	014298	Roller, Flanged Blade Guide (1 1/2" blade)	Available in assemblies only.	1
	A04925-364	Instruction Sheet, Blade Guide Roller Replacement		1
14	S04253	Spacer, Blade Guide		2
15	F05011-125	Washer, 1/2" Nord-Lock		1
16	F05008-10	Bolt, 1/2-13 x 2 1/4" Hex Head Grade 5		1
17	F05011-17	Washer, 5/16" SAE Flat		2
18	F05011-13	Washer, 5/16" Split Lock		2
19	F05006-76	Bolt, 5/16-18 x 1 1/2" Hex Head		2
20	035656	Bolt, Blade Guide Vertical Adjustment		1
21	F05010-17	Nut, 5/16-18 Hex		1
22	F05006-16	Bolt, 5/16-18 x 2 1/4" Hex Head Full Thread		1
	003927	<b>BLOCK ASSEMBLY, DRIVE SIDE BLADE GUIDE</b>		1
23	003915	Plate, Block Tilt Adjustment		1
24	003909	Block, Guide Block Mount		1
25	F05012-22	Pin, 3/16" x 5/8" Roll		2
26	F05011-3	Washer, 3/8" SAE Flat		1
27	F05011-4	Washer, 3/8" Split Lock		1
28	F05007-123	Bolt, 3/8-16 x 1 1/4" Hex Head Grade 5		1
29	F05006-102	Bolt, 5/16-18 x 3/4" Hex Head		1
30	003914	Ball, 3/16" Dia. Nylon		2
31	F05011-14	Washer, 1/4" Split Lock		2
32	F05005-15	Bolt, 1/4-20 x 1/2" Hex Head		2
33	003994	Bolt, Blade Guide Block Mount		1
34	042867	Washer, #10 Brass		1
35	F05004-240	Bolt, #10-32 x 1 1/4" Hex Head Stainless Steel		1
36	044057	Screw, Lower Block Adjustment		1
37	F05004-200	Screw, #10-32 x 3/8" Socket Head Stainless Steel		1
38	F05011-17	Washer, 5/16" SAE Flat		1
39	F05011-13	Washer, 5/16" Split Lock		1
40	052355	<b>BLOCK, BLADE GUIDE WEAR (STANDARD FOR 1 1/4" BLADES)</b>	052355 blocks for use with 1 1/4" blade provided as standard equipment. 052309 blocks available for optional use with 1 1/2" blades. Use kit 006382 to convert the rollers and guide blocks for both blade guides for 1 1/2" blades. EZ-Glide blocks 036347 are available for customers who prefer this block.	2
	052309	<b>BLOCK, BLADE GUIDE WEAR (OPTIONAL FOR 1 1/2" BLADES)</b>		2
	036347	<b>BLOCK ASSEMBLY, 1" SQ. EZ-GLIDE WEAR</b>		2
41	035799	<b>BLOCK, BLADE GUIDE ALIGNMENT</b>		1

REF	PART #	DESCRIPTION	COMMENTS	QTY.
42	F05011-20	WASHER, #10 SPLIT LOCK		1
43	F05004-152	SCREW, #10-32 X 5/8" HEX HEAD		1
44	044064	ADJUSTMENT TOOL, LOWER GUIDE BLOCK		1
45	035248	SHIM, .008" BLADE GUIDE BLOCK SPACER		1

## 2.6 Outer Blade Guide Assembly

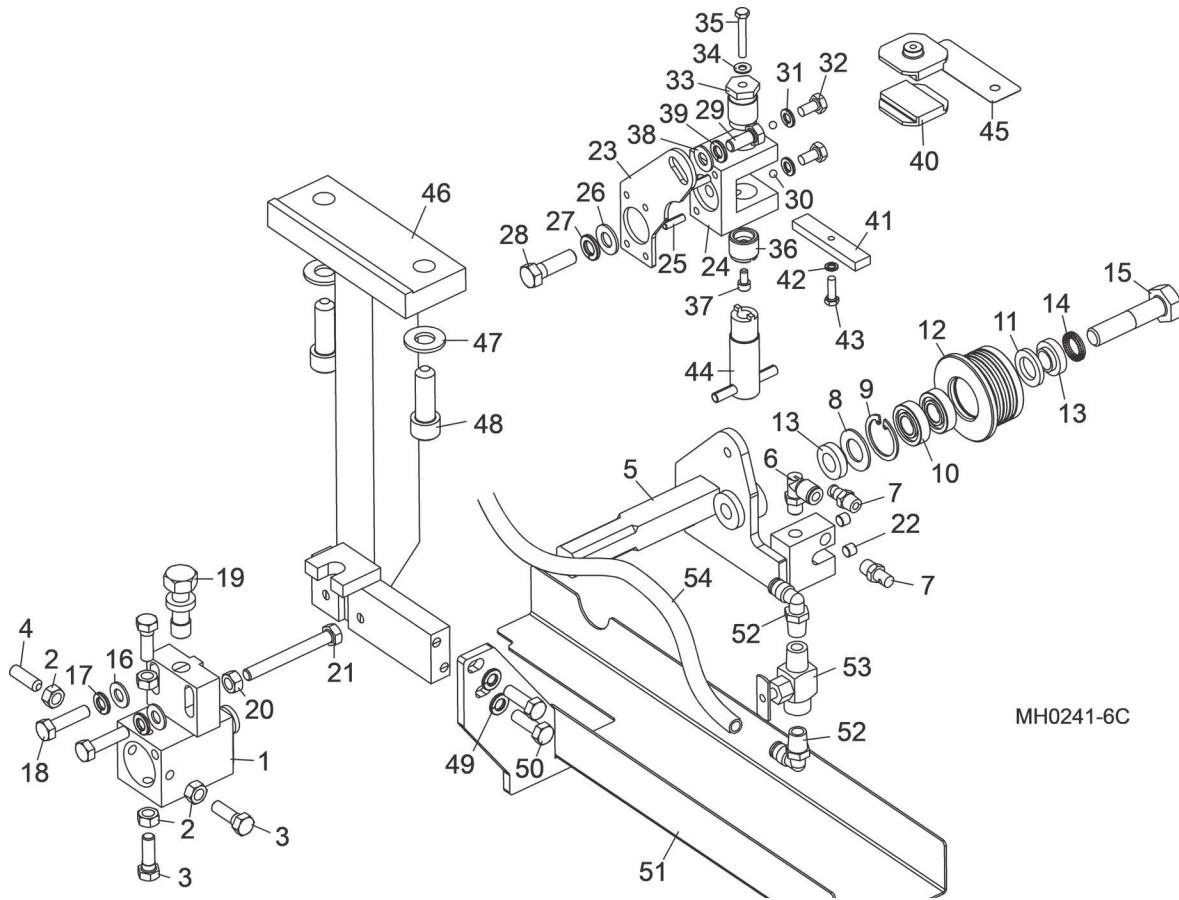

REF	PART #	DESCRIPTION	COMMENTS	QTY.
	008996	<b>GUIDE ASSEMBLY, OUTER BLADE GUIDE</b>		1*
	065677	Block Assembly, Idle Side Blade Guide Mount		1
1	003911	Block Weldment, Blade Guide Mount	Available in assemblies only.	1
2	F05010-17	Nut, 5/16-18 Hex		4
3	F05006-88	Bolt, 5/16-18 x 1" Hex Head Stainless Steel		3
4	F05006-122	Screw, 5/16-18 x 1" Socket Head Flat Point Stainless Steel Set		1
5	003924	Shaft Weldment, Idle Side Guide		1
6	P09736	Fitting, 1/8MPTx1/4Tube Elbow Swivel		1
7	033479	Fitting, Blade Lube Spray Nozzle		2
	A04925	Roller Assembly, Blade Guide (standard for use with 1 1/4" & 1 1/2" blades)	The resaw is equipped standard with blade guide rollers that can be used with the standard 1 1/4" blade or 1 1/2" blades. Optional extended blade guide rollers are available for use with 1 1/2" blades. The extended rollers may provide more stability during difficult sawing, but will reduce the total amount of times the blade can be reused after sharpening. Use kit 006382 to convert the rollers and guide blocks for both blade guides for 1 1/2" blades.	1
	014299	Roller Assembly, Extended Blade Guide (optional for use with 1 1/2" blades)		1
	K07079	Bearing Kit, Blade Guide Rebuild		1



REF	PART #	DESCRIPTION	COMMENTS	QTY.
8	P04252	Washer, 5/8" White Felt		1
9	F04254-1	Ring, 1 1/8" Interior Retaining		1
10	015975	Bearing, R8-2RS Blade Guide	Available in assemblies only.	2
11	P06455	Washer, 5/8" Gray Felt		1
	F05005-105	Screw, 1/4-28 x 1/4" Socket Head Cup Point Set Black Oxide		1
	057407-1507	Instruction Sheet, Blade Guide Rebuild		1
12	S04250	Roller, Flanged Blade Guide (1 1/4" & 1 1/2" blade)	Available in assemblies only.	1
	014298	Roller, Flanged Blade Guide (1 1/2" blade)	Available in assemblies only.	1
	A04925-364	Instruction Sheet, Blade Guide Roller Replacement		1
13	S04253	Spacer, Blade Guide		2
14	F05011-125	Washer, 1/2" Nord-Lock		1
15	F05008-10	Bolt, 1/2-13 x 2 1/4" Hex Head Grade 5		1
16	F05011-17	Washer, 5/16" SAE Flat		2
17	F05011-13	Washer, 5/16" Split Lock		2
18	F05006-118	Bolt, 5/16-18 x 1 1/4" Hex Head Stainless Steel		2
19	035656	Bolt, Blade Guide Vertical Adjustment		1
20	F05010-17	Nut, 5/16-18 Hex		1
21	F05006-136	Bolt, 5/16-18 x 2 3/4" Hex Head Full Thread		1
22	007734	Fitting, 1/16" NPT Plug		2
	024155	Clamp, 1/4" Wire 13/32" Mounting Hole		2
	003928	Block Assembly, Idle Side Blade Guide		1
23	003915	Plate, Block Tilt Adjustment		1
24	003909	Block, Guide Block Mount		1
25	F05012-22	Pin, 3/16" x 5/8" Roll		2
26	F05011-3	Washer, 3/8" SAE Flat		1
27	F05011-4	Washer, 3/8" Split Lock		1
28	F05007-123	Bolt, 3/8-16 x 1 1/4" Hex Head Grade 5		1
29	F05006-102	Bolt, 5/16-18 x 3/4" Hex Head		1
30	003914	Ball, 3/16" Dia. Nylon		2
31	F05011-14	Washer, 1/4" Split Lock		2
32	F05005-15	Bolt, 1/4-20 x 1/2" Hex Head		2
33	003994	Bolt, Blade Guide Block Mount		1
34	042867	Washer, #10 Brass		1
35	F05004-240	Bolt, #10-32 x 1 1/4" Hex Head Stainless Steel		1
36	044057	Screw, Lower Block Adjustment		1
37	F05004-200	Screw, #10-32 x 3/8" Socket Head Stain- less Steel		1
38	F05011-17	Washer, 5/16" SAE Flat		1
39	F05011-13	Washer, 5/16" Split Lock		1

REF	PART #	DESCRIPTION	COMMENTS	QTY.
40	052355	<b>BLOCK, BLADE GUIDE WEAR (STANDARD FOR 1 1/4" BLADES)</b>	052355 blocks for use with 1 1/4" blade provided as standard equipment. 052309 blocks available for optional use with 1 1/2" blades. Use kit 006382 to convert the rollers and guide blocks for both blade guides for 1 1/2" blades. EZ-Glide blocks 036347 are available for customers who prefer this block.	2
	052309	<b>BLOCK, BLADE GUIDE WEAR (OPTIONAL FOR 1 1/2" BLADES)</b>		2
	036347	<b>BLOCK ASSEMBLY, 1" SQ. EZ-GLIDE WEAR</b>		2
41	035799	<b>BLOCK, BLADE GUIDE ALIGNMENT</b>		1
42	F05011-20	<b>WASHER, #10 SPLIT LOCK</b>		1
43	F05004-152	<b>SCREW, #10-32 X 5/8" HEX HEAD</b>		1
44	044064	<b>ADJUSTMENT TOOL, LOWER GUIDE BLOCK</b>		1
45	035248	<b>SHIM, .008" BLADE GUIDE BLOCK SPACER</b>		1
46	007689	<b>ARM WELDMENT, HR1000 BLADE GUIDE</b>		1*
47	F05011-2	<b>WASHER, 1/2" SAE FLAT</b>		2*
48	F05008-44	<b>BOLT, 1/2-20 X 1 1/2" SOCKET HEAD</b>		2*
49	F05011-13	<b>WASHER, 5/16" SPLIT LOCK</b>		2*
50	F05006-27	<b>BOLT, 5/16-18 X 1" HEX HEAD GRADE 5</b>		2*
51	007692	<b>GUARD, HR1000 OUTER BLADE GUIDE</b>		1*
52	P21519	<b>FITTING, 1/4" NPT X 1/4" TUBE 90°</b>		2
53	P05680	<b>VALVE, WATER SHUTOFF</b>		1*
54	R01869	<b>HOSE, 1/4" O.D. PLASTIC</b>		As Req'd

## 2.7 Up/Down Assembly

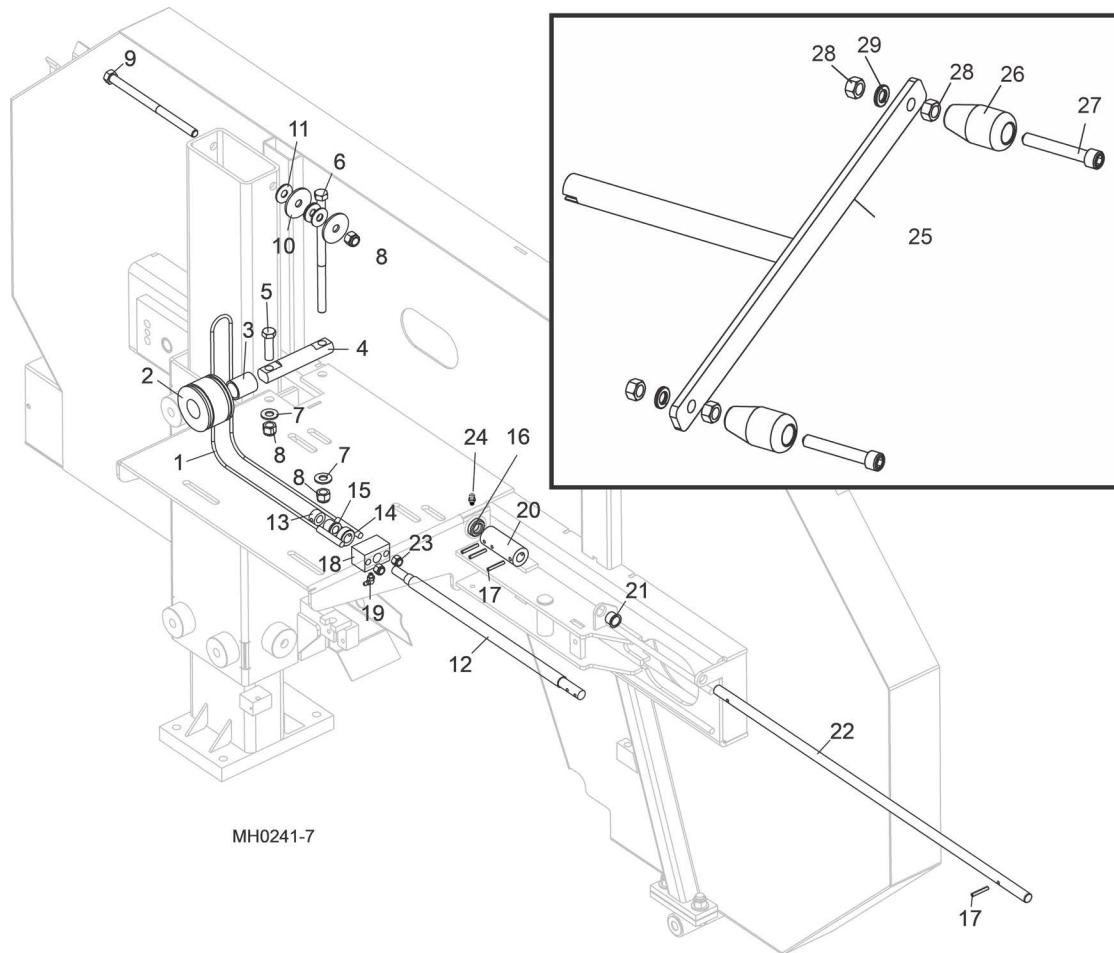

REF	PART #	DESCRIPTION	COMMENTS	QTY.
1	S22307	CABLE, MULTIHEAD UP/DOWN		1
2	S22205	PULLEY, 2-GROOVE UP/DOWN CABLE		1
3	P05041	BUSHING, 1" X 1 1/4" X 1 1/2" BRONZE		1
4	007672	PIN, CABLE PULLEY MOUNT		1
5	F05008-88	BOLT, 1/2-13 X 1 3/4" HEX HEAD GRADE 5		1
6	F05008-147	BOLT, 1/2-13 X 8 1/2" HEX HEAD GRADE 5		1
7	F05011-2	WASHER, 1/2" SAE FLAT		2
8	F05010-8	NUT, 1/2-13 HEX NYLON LOCK		3
9	F05008-69	BOLT, 1/2-13 X 8" HEX HEAD GRADE 5		1
10	F05011-38	WASHER, 1/2" I.D. X 2" O.D. FENDER		2
11	F05011-35	WASHER, 7/16" STANDARD FLAT		4
	130142	ASSY, HR1000 HEIGHT ADJUST		1
12	130141	ROD, HEIGHT ADJUSTMENT		1
	S22208	ROD, UP/DOWN THREADED		1
13	014820	COLLAR, 1/2" I.D. SHAFT		1
14	P05035	COLLAR, 5/8" I.D. SHAFT		1
15	P22317	BUSHING, 1/2" X 3/4" FLANGED BRONZE		1
16	130128 <sup>L</sup>	BEARING, THRUST 51102 15MM X 28MM X 9MM		1
	P04214	BEARING, 5/8" THRUST		1

**2** Saw Head Parts  
Up/Down Assembly

REF	PART #	DESCRIPTION	COMMENTS	QTY.
17	F05012-16	PIN, 3/16" X 1 1/4" ROLL		4
18	S22209	BLOCK, HEIGHT ADJUSTMENT		1
19	P04108	FITTING, 1/4-28 90° GREASE		1
20	S22476	COUPLING, UP/DOWN CRANK		1
21	P22478	BUSHING, .635 ID X .750 OD NYLON FLANGED		2
22	007705	SHAFT, MH HEAD CRANK		1
23	F05010-10	<b>NUT, 3/8-16 HEX NYLON LOCK</b>		2
24	P04107	<b>FITTING, 3/16X3/16 STRAIGHT GREASE</b>		1
	033251	<b>CRANK HANDLE ASSEMBLY</b>		1
25	033253	Handle Weldment, Crank		1
26	060170	Knob, 3/8" Bore Tapered Plastic		2
27	F05007-111	Screw, 3/8-16 x 3 1/2" Socket Head Cap		2
28	F05010-29	Nut, 3/8-16 Jam		4
29	F05011-4	Washer, 3/8" Split Lock		2

## 2.8 Blade Wheel Assembly (Drive Side)

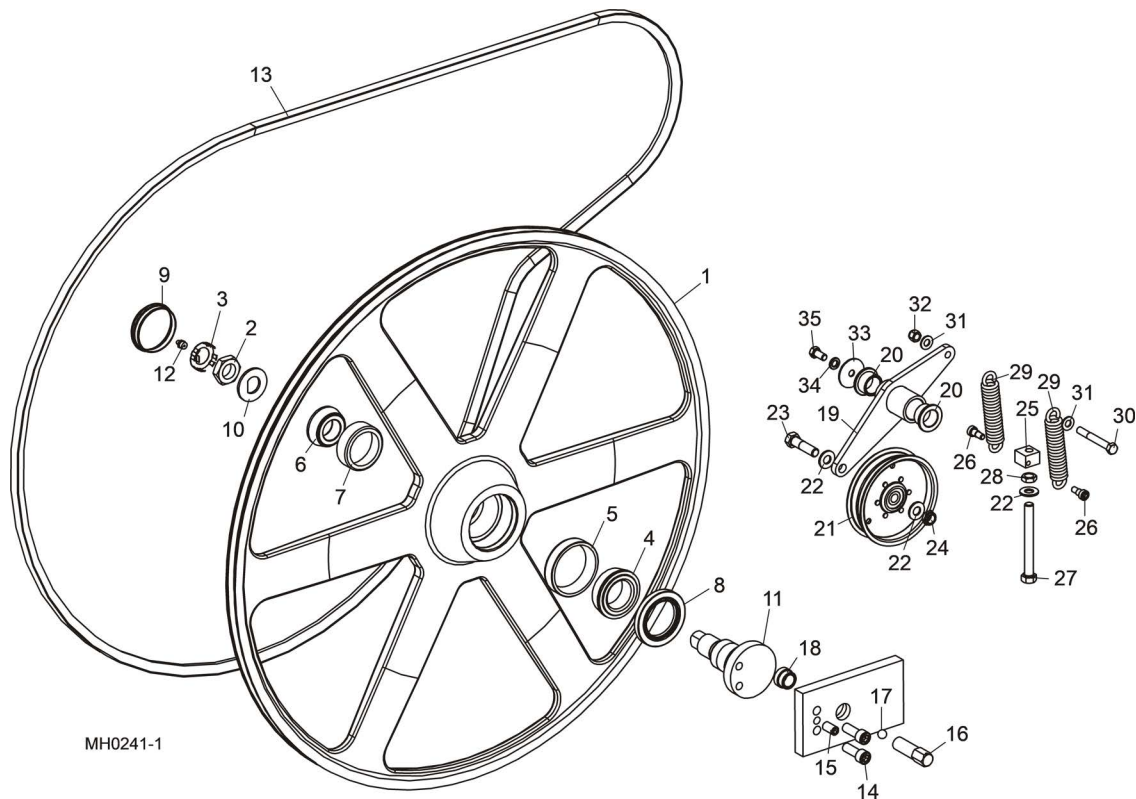

REF	PART #	DESCRIPTION	COMMENTS	QTY.
	006553	<b>WHEEL ASSEMBLY, 34" HR1000 BLADE</b>		1*
<b>1</b>	006544	Wheel, 34" Cast Blade	Available in assemblies only.	1
	007656	Nut Assembly, Spindle w/Retainer		1
<b>2</b>	007654	Nut, 1-14 Spindle		1
<b>3</b>	007655	Retainer, Spindle Nut		1
	061227	Bearing Kit, Blade Wheel		1
<b>4</b>	045208	Bearing, Inner		1
<b>5</b>	045209	Race, Inner Bearing		1
<b>6</b>	045210	Bearing, Outer		1
<b>7</b>	045211	Race, Outer Bearing		1
<b>8</b>	045212	Seal, Blade Wheel Bearing		1
<b>9</b>	033238	Cap, Hub Dust		1
<b>10</b>	045214	Washer, Spindle 'D'		1
<b>11</b>	006545	Shaft, HR1000 Spindle		1
<b>12</b>	P108	Fitting, 1/8" NPT Straight Grease		1
<b>13</b>	007723	<b>BELT, 5VX1320</b>		1
<b>14</b>	F05008-44	<b>SCREW, 1/2-20 X 1 1/2" SOCKET HEAD CAP</b>		2*
<b>15</b>	F05008-9	<b>SCREW, 1/2-13 X 1" OVAL POINT SET NYLON LOCK</b>		1*
	007652	<b>SCREW ASSEMBLY, BLADE WHEEL TILT</b>		1*
<b>16</b>	007651	Screw, Cant Adjustment	Available in assemblies only.	1
<b>17</b>	P02720	Ball, 1/2" Diameter Detent		1
<b>18</b>	007627	<b>BUSHING, 3/4-32 THREADED</b>	Bushing is welded to C-frame block. Factory removal and installation recommended.	1*

REF	PART #	DESCRIPTION	COMMENTS	QTY.
	007703	<b>TENSIONER ASSEMBLY, HR1000 DRIVE BELT</b>		1*
19	007700	Idler Weldment, HR1000 Belt Tension		1
20	P737	Bushing, 1 x 1 1/4" x 3/4" Flanged Bronze		2
21	043367	Pulley, 5" OD Idler		1
22	F05011-2	Washer, 1/2" SAE Flat		3
23	F05008-76	Bolt, 1/2-13 x 2" Hex Head		1
24	F05010-127	Nut, 1/2-13 Half Nylon Lock		1
25	007701	Block, HR1000 Drive Belt Tensioner		1
26	F05007-159	Bolt, 3/8" x 3/8" Socket Head Shoulder		2
27	F05008-16	Bolt, 1/2-13 x 4 1/2" Hex Head Full Thread		1
28	F05010-31	Nut, 1/2-13 Hex Jam		1
29	021185	Spring, 1" OD x 4 1/2" Long x .192 Wire Compression		2
30	F05007-73	Bolt, 3/8-16 x 3" Hex Head Grade 5		1
31	F05011-3	Washer, 3/8" SAE Flat		2
32	F05010-10	Nut, 3/8-16 Hex Nylon Lock		1
33	036931	Washer, .39" ID x 1.75" OD x 14Ga.		1
34	F05011-4	Washer, 3/8" Split Lock		1
35	F05007-118	Bolt, 3/8-16 x 3/4" Hex Head Grade 5		1

## 2.9 Blade Wheel Assembly (Idle Side)

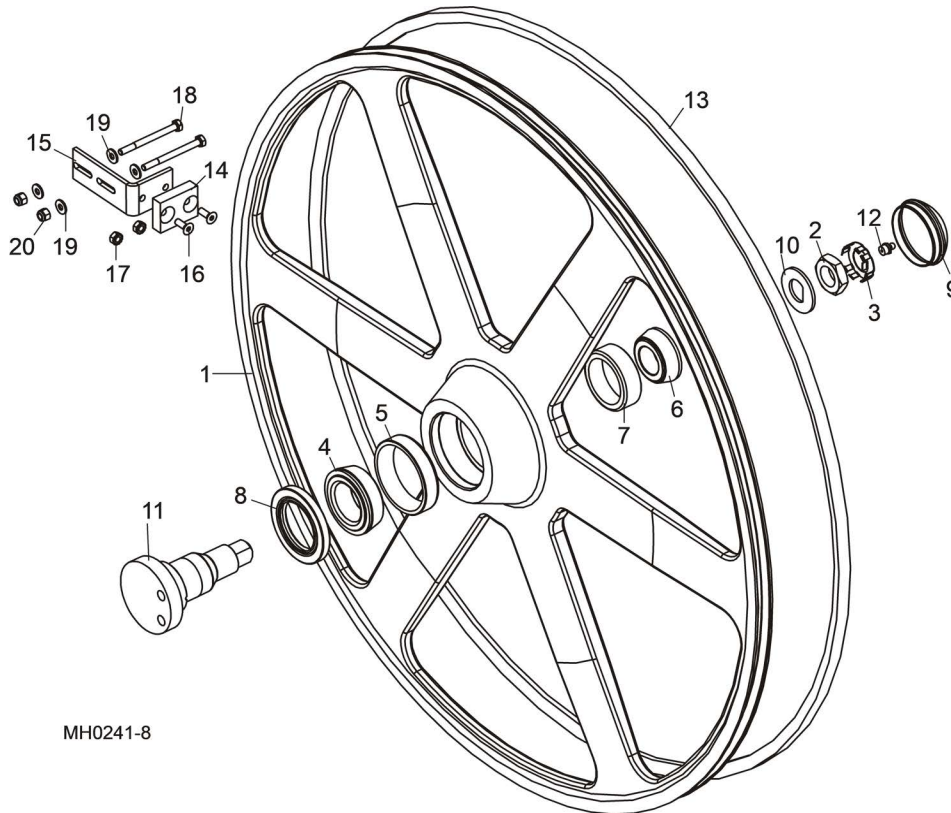

MH0241-8

REF	PART #	DESCRIPTION	COMMENTS	QTY.
	006553	<b>WHEEL ASSEMBLY, 34" HR1000 BLADE</b>		1*
1	006544	Wheel, 34" Cast Blade	Available in assemblies only.	1
	007656	Nut Assembly, Spindle w/Retainer		1
2	007654	Nut, 1-14 Spindle		1
3	007655	Retainer, Spindle Nut		1
	061227	Bearing Kit, Blade Wheel		1
4	045208	Bearing, Inner		1
5	045209	Race, Inner Bearing		1
6	045210	Bearing, Outer		1
7	045211	Race, Outer Bearing		1
8	045212	Seal, Blade Wheel Bearing		1
9	033238	Cap, Hub Dust		1
10	045214	Washer, Spindle 'D'		1
11	006545	Shaft, HR1000 Spindle		1
12	P108	Fitting, 1/8" NPT Straight Grease		1
13	033391	<b>BELT, 5VX1080</b>		1
	A22901	<b>BRAKE PAD ASSEMBLY</b>	Available in assemblies only.	1*
14	S22200	Pad, Wheel Brake		1
15	S22201	Bracket, Brake Pad Mount		1
16	F05005-70	Screw, 1/4-20 x 3/4" Flat Socket Head		2
17	F05010-9	Nut, 1/4-20 Hex Self-Locking		2
18	F05005-127	<b>BOLT, 1/4-20 X 3" HEX HEAD GRADE 5</b>		2
19	F05011-11	<b>WASHER, 1/4" SAE FLAT</b>		4
20	F05010-69	<b>NUT, 1/4-20 HEX NYLON LOCK</b>		2

## 2.10 Blade Housing Cover

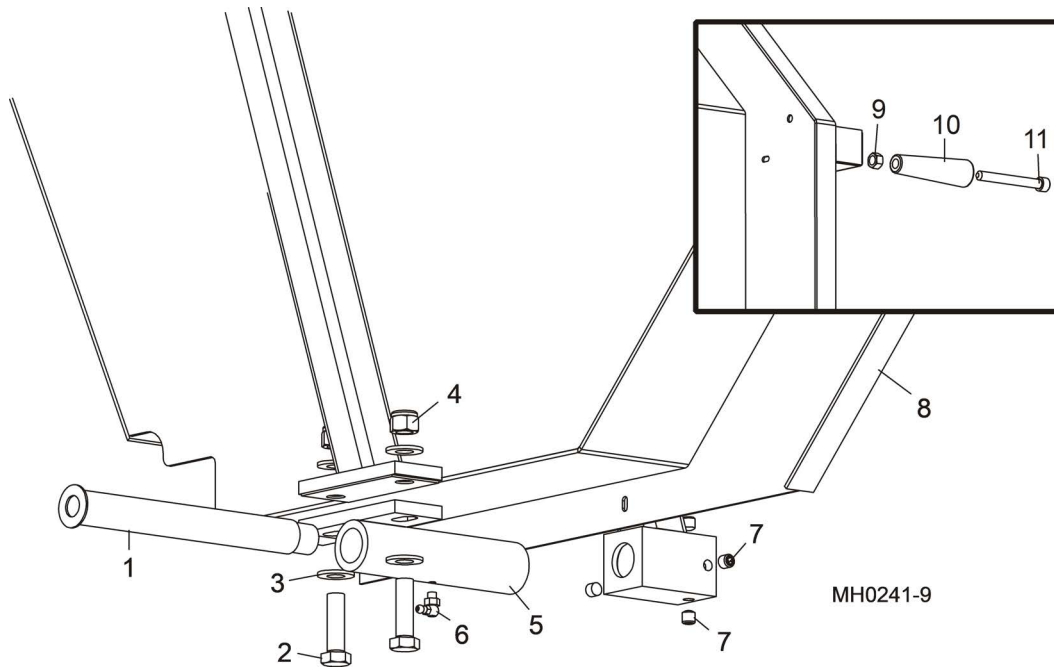

REF	PART #	DESCRIPTION	COMMENTS	QTY.
1	W22064	PIN WELDMENT, COVER PIVOT		1
2	F05008-88	BOLT, 1/2-13 X 1 3/4" HEX HEAD GRADE 5		2
3	F05011-2	WASHER, 1/2" SAE FLAT		4
4	F05010-8	NUT, 1/2-13 HEX NYLON LOCK		2
5	W22623	TUBE WELDMENT, COVER PIVOT		1
6	P04108	FITTING, 1/4-28 GREASE 90°		1
7	F05007-13	SCREW, 3/8-16 X 3/8" SOCKET HEAD OVAL POINT SET		4
8	007698	COVER WELDMENT, HR1000 BLADE HOUSING		1
9	F05010-1	NUT, 3/8-16 HEX		1
10	060170	KNOB, COVER PIVOT		1
11	F05007-111	BOLT, 3/8-16 X 3 1/2" SOCKET HEAD		1



## 2.11 Sawdust Chute

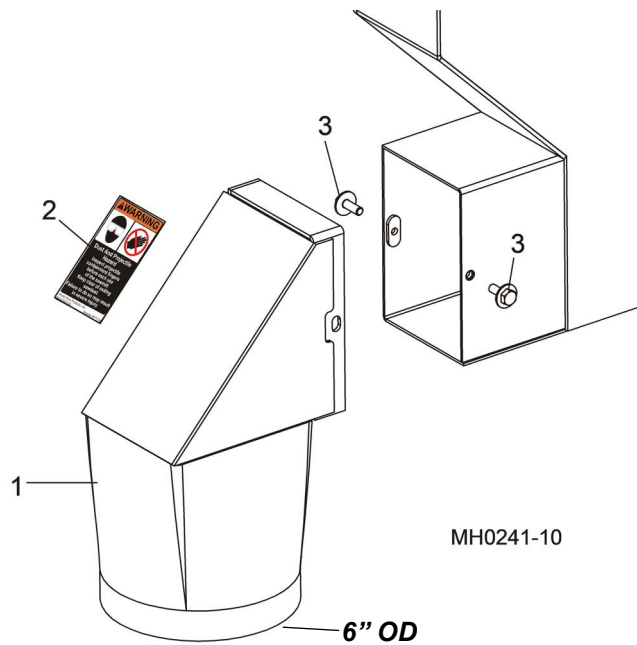

REF	PART #	DESCRIPTION	COMMENTS	QTY.
1	W22556	CHUTE WELDMENT, SAWDUST EXTENSION	6" OD	1
2	P11754	DECAL, SAWDUST CHUTE WARNING		1
3	F05005-207	BOLT, 1/4-20 X 3/4" HEX HEAD W/WASHER&PATCH		2

## 2.12 Saw Head Decals

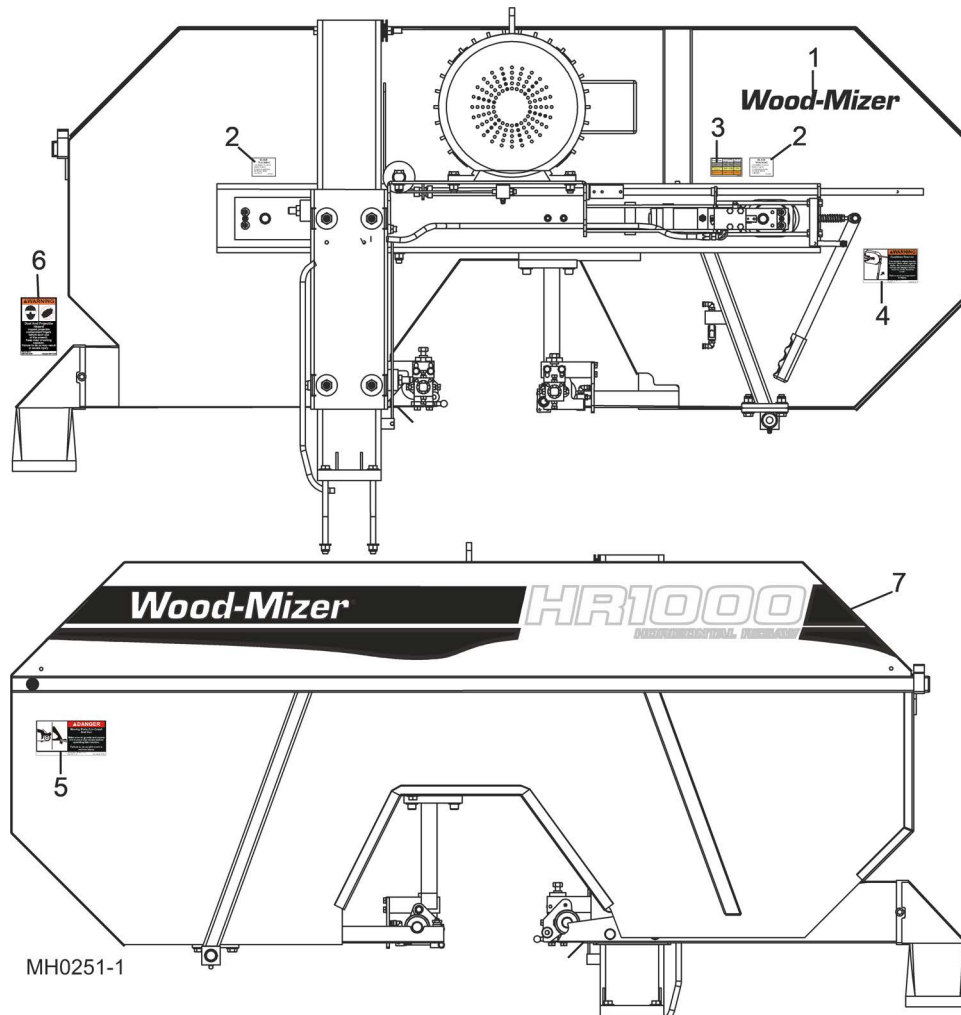

REF	PART #	DESCRIPTION	COMMENTS	QTY.
1	052281	DECAL, WOOD-MIZER LOGO 15"		1
2	P22454	DECAL, BLADE ALIGNMENT		2*
3	P22653	DECAL, BLADE TENSION		1*
4	P22519	DECAL, BLADE BRAKE WARNING		1*
5	033254	DECAL, MOVING PARTS DANGER		1*
6	P11754	DECAL, SAWDUST CHUTE WARNING		1*
7	110730	DECAL, HR1000 LOGO		1

## SECTION 3 FEED TRACK/FRAME PARTS

### 3.1 Hydraulic Blade Tensioner Assembly

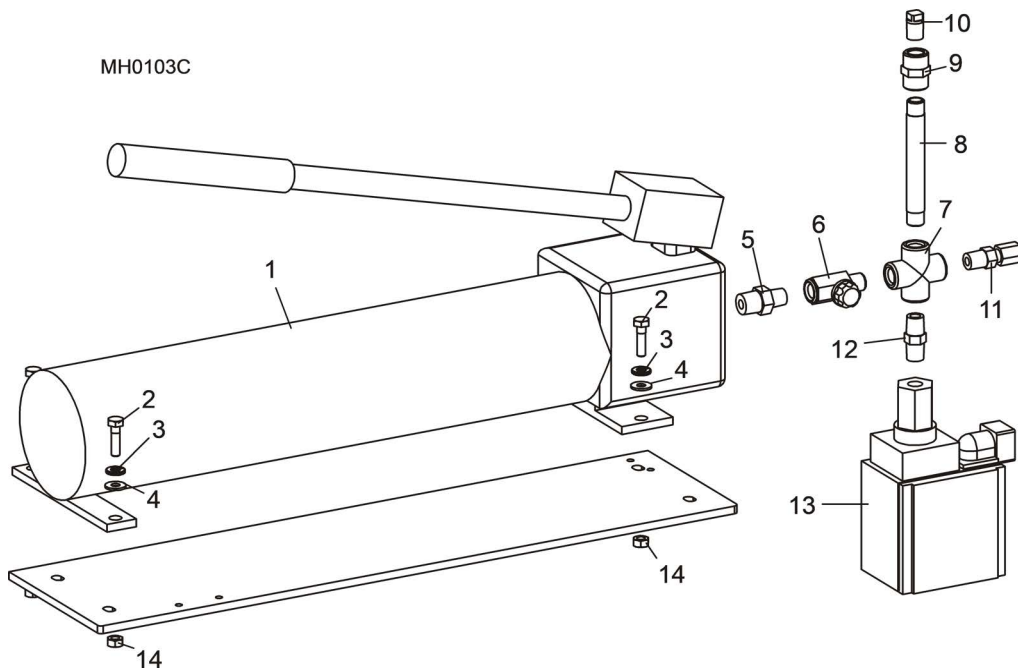

REF	PART #	DESCRIPTION	COMMENTS	QTY.
1	P22302	PUMP, HYDRAULIC 2-STAGE HAND		1
	P22310	PUMP, HYDRAULIC 2-STAGE HAND (5-6 HEADS)	Available in assemblies only. P22310 Hand Pump used on 5 & 6 head machines prior to Rev. A3.00 and is no longer available. Use P22302.	1
2	F05005-101	BOLT, 1/4-20 X 1" HEX HEAD		4
3	F05011-14	WASHER, 1/4" SPLIT LOCK		4
4	F05011-11	WASHER, 1/4" SAE FLAT		4
5	P05381	FITTING, 3/8" NPT - 1/4" NPT STRAIGHT		1
6	P22314	VALVE, HYDRAULIC SHUTOFF		1
7	P22311	FITTING, 1/4" NPT CROSS		1
8	016428	FITTING, 1/4" NPT X 4" NIPPLE		1
9	P03420	FITTING, 1/4" NPT COUPLING		1
10	P05498	PLUG, 1/4" NPT PIPE		1
11	P22518	FITTING, 1/4" NPT X 1/4" TUBE		1
12	P05389	FITTING, 1/4" NPT STRAIGHT		1
13	E22726	SWITCH, HYDRAULIC PRESSURE SHUT-OFF		1
14	F05010-63	NUT, 1/4-20 HEX		4

### 3.2 Perimeter Fence Assembly

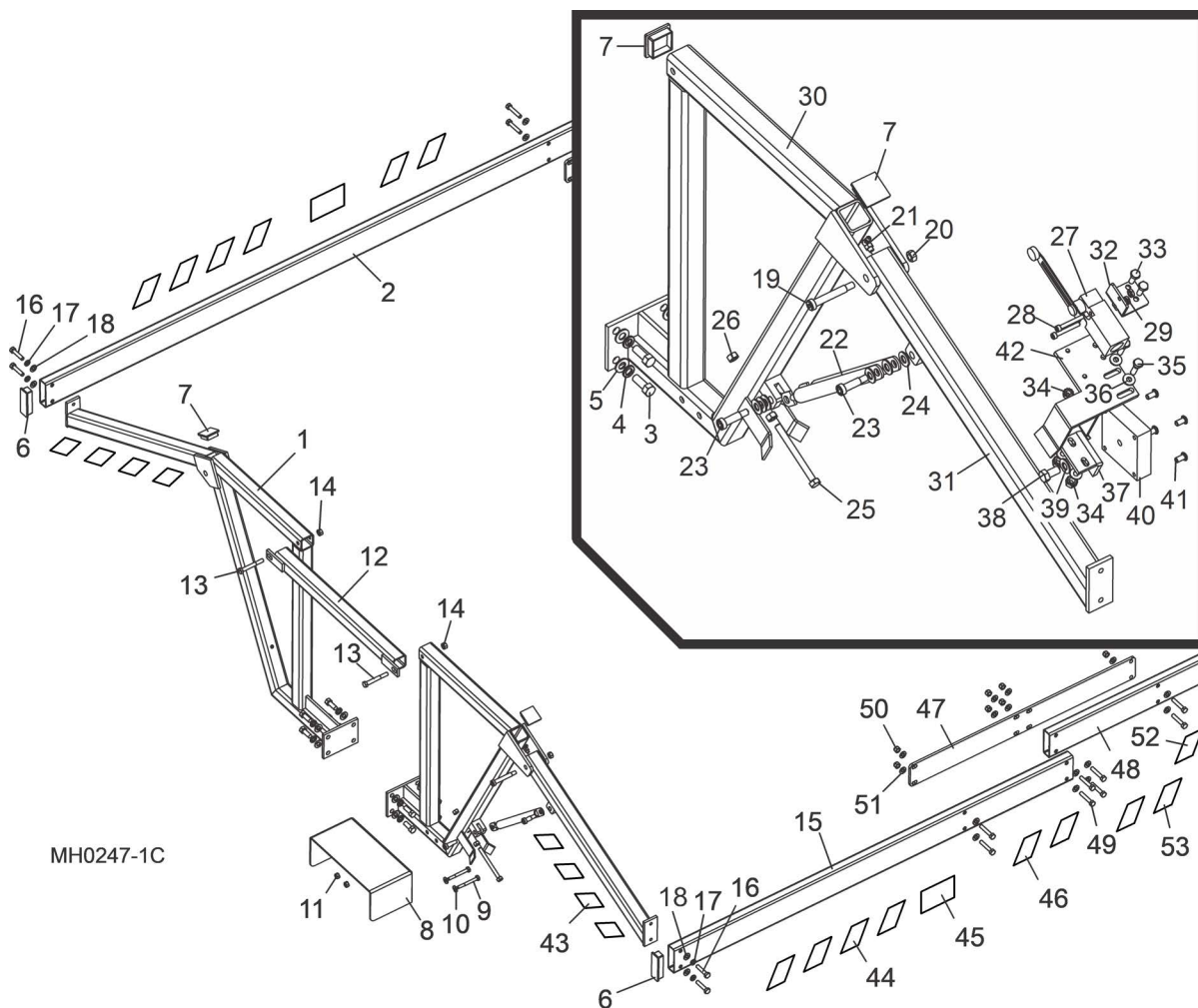

MH0247-1C

REF	PART #	DESCRIPTION	COMMENTS	QTY.
1	W22168	BRACKET, FIXED PERIMETER FENCE MOUNT		2
2	074964	TUBE, RAIL 72		1
3	F05007-7	BOLT, 3/8-16 X 1" HEX HEAD		16
4	F05011-4	WASHER, 3/8" SPLIT LOCK		16
5	F05011-3	WASHER, 3/8" SAE FLAT		16
6	P22522	PLUG, 1" X 3" PLASTIC		4
7	P22321	PLUG, 1 1/2" SQUARE PLASTIC		5
8	W22081	GUARD WELDMENT, REMOTE CONTROL SWITCH		1
9	F05005-72	BOLT, 1/4-20 X 2 1/4" HEX HEAD		2
10	F05011-11	WASHER, 1/4" SAE FLAT		2
11	F05010-9	NUT, 1/4-20 HEX SELF-LOCKING		2
12	W22185	TUBE, PERIMETER FENCE CROSS		1
13	F05006-10	BOLT, 5/16-18 X 2 1/2" HEX HEAD		4
14	F05010-20	NUT, 5/16-18 SELF-LOCKING HEX		4

REF	PART #	DESCRIPTION	COMMENTS	QTY.
15	074965	TUBE, RAIL 47	Use 5/8" long shoulder bolt F05007-79 to mount single piston. Use 1" long shoulder bolt F05006-25 to mount dual pistons supplied on 5 & 6 head models.	1
16	F05006-2	BOLT, 5/16-18 X 1 1/2" HEX HEAD FULL THREAD		8
17	F05011-13	WASHER, 5/16" SPLIT LOCK		8
18	F05011-17	WASHER, 5/16" SAE FLAT		8
19	F05006-26	BOLT, 3/8" X 2" SHOULDER (5/16-18 THREAD)		2
20	F05010-6	NUT, 5/16-18 LOCK		2
21	P04108	FITTING, 1/4-28 90°GREASE		2
22	P22309	PISTON, PERIMETER FENCE GAS		3
23	F05007-79	BOLT, 3/8" X 5/8" SHOULDER (5/16-18 THREAD)	Use 5/8" long shoulder bolt F05007-79 to mount single piston. Use 1" long shoulder bolt F05006-25 to mount dual pistons supplied on 5 & 6 head models.	4
	F05006-25	BOLT, 3/8" X 1" X 5/16-18 SHOULDER		2
24	F05011-3	WASHER, 3/8" SAE FLAT	For dual pistons supplied on 5 & 6 head models only.	6
25	F05006-3	BOLT, 5/16-18 X 3 1/2" HEX HEAD FULL THREAD		2
26	F05010-17	NUT, 5/16-18 HEX		4
27	039378	SWITCH, PERIMETER FENCE LIMIT		1
28	F05004-51	BOLT, #10-24 X 1 1/2" SOCKET HEAD		2
29	F05010-14	NUT, #10-24 SELF-LOCKING HEX		2
30	W22441	BRACKET, SWINGING PERIMETER FENCE MOUNT		2
31	W22179	ARM, SWINGING PERIMETER FENCE		2
32	065580	BRACKET, PERIMETER SWITCH MOUNT		1
33	F05005-1	BOLT, 1/4-20 X 3/4" HEX HEAD FULL THREAD		2
34	F05010-9	NUT, 1/4-20 HEX SELF LOCKING		4
35	F05005-101	BOLT, 1/4-20 X 1" HEX HEAD GRADE 5		2
36	F05011-11	WASHER, 1/4" SAE FLAT		4
37	S22243	BRACKET, PERIMETER FENCE SWITCH "L"		1
38	F05007-27	BOLT, 3/8-16 X 3/4" HEX HEAD GRADE 2		1
39	F05011-3	WASHER, 3/8" SAE FLAT		1
40	033398	PLATE, PERIMETER FENCE SAFETY SWITCH		1
41	F05005-59	SCREW, 1/4-20 X 1/2" BUTTON SOCKET HEAD		4
42	W22246	BRACKET, PERIMETER FENCE SAFETY SWITCH MOUNTING		1
43	S22530-1	DECAL, MULTIHEAD FENCE END (4 STRIPES)		7
44	074978	DECAL, MULTIHEAD FENCE SIDE (4 STRIPES)		8
45	P22687	DECAL, PERIMETER FENCE WARNING		4
	074966	RAIL ASSEMBLY, 56	Use 5/8" long shoulder bolt F05007-79 to mount single piston. Use 1" long shoulder bolt F05006-25 to mount dual pistons supplied on 5 & 6 head models.	2/4/6*
46	074962	Plate, Rail Joint		1

### 3 Feed Track/Frame Parts

#### Perimeter Fence Assembly

REF	PART #	DESCRIPTION	COMMENTS	QTY.
47	074963	Tube, Rail 56		1
48	F05006-81	Bolt, 5/16-18x1 3/4" Full Thread Hex Head Grade 5		8
49	F05010-58	Nut, 5/16-18 Nylok Hex		8
50	F05011-17	Washer, 5/16" SAE Flat		16
51	074978	Decal, Multihead Fence Side (4 Stripes)		4
* Number of Saw Heads=Number of Rail Assemblies.				

### 3.3 Feed Track Assembly

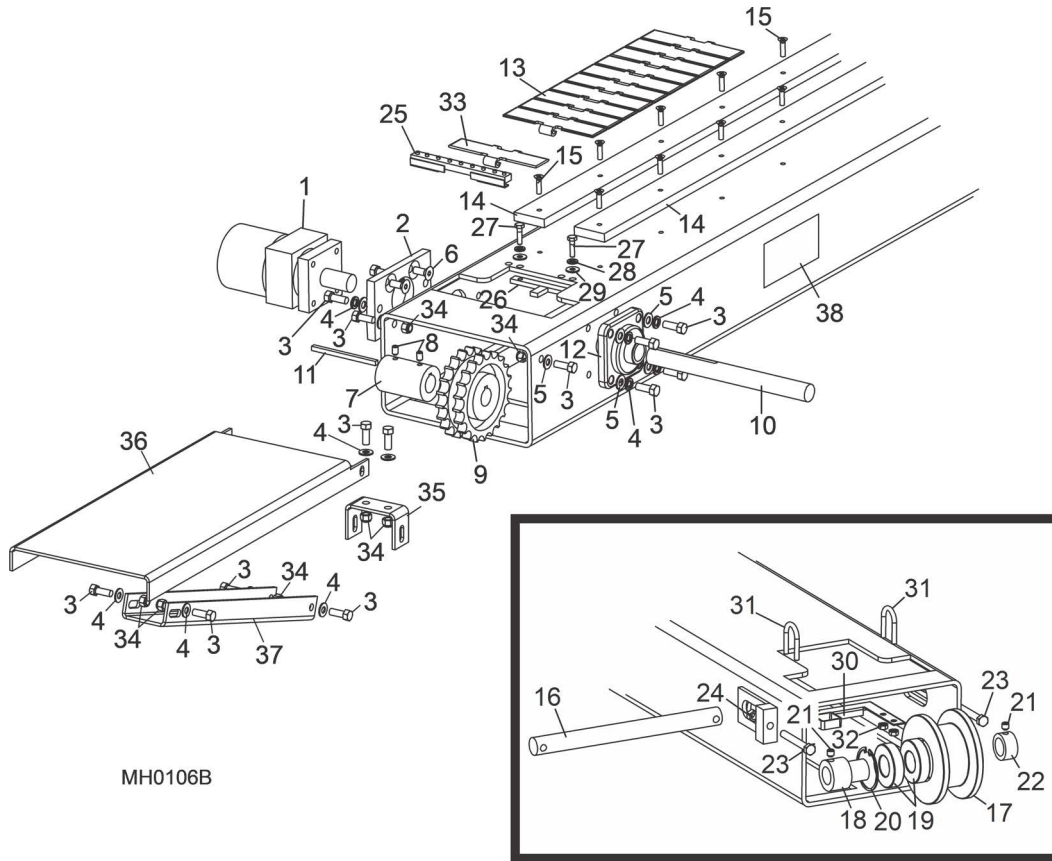

MH0106B

REF	PART #	DESCRIPTION	COMMENTS	QTY.
1	P20206	<b>MOTOR, MG10-13-10AAAB HYDRAULIC</b>		1
	061136	Kit, Hydraulic Motor Seal		1
2	S20173	<b>PLATE, FEED TRACK MOTOR MOUNT</b>		1
3	F05007-7	<b>BOLT, 3/8-16 X 1" HEX HEAD</b>		14
4	F05011-4	<b>WASHER, 3/8" SPLIT LOCK</b>		6
5	F05011-3	<b>WASHER, 3/8" SAE FLAT</b>		14
6	F05007-64	<b>SCREW, 3/8-16 X 1" FLAT SOCKET HEAD</b>		4
7	S20185	<b>COUPLING, FEED TRACK MOTOR SHAFT</b>		1
8	F05006-38	<b>SCREW, 5/16-18 X 1/2" SOCKET HEAD SET</b>		2
9	P20202	<b>SPROCKET, 21-22T FEED TRACK DRIVE</b>		1
10	S22428	<b>SHAFT, FEED TRACK DRIVE</b>		1
11	S22440	<b>KEY, 1/4" SQUARE X 4.25"</b>		1
12	P20201	<b>BEARING, VJC 1 FLANGED</b>		1
13	P22427 (10 Ft.)	<b>CHAIN, 7 1/2" FLAT FEED</b>	1/2 Head machines require 23' of track chain; 3/4 Heads , 34'; 5/6 Heads, 46'.	As Req'd
	079207 (1 Ft.)	Chain, 7.5" Flat Feed Track		As Req'd
	022424	Pin, Track Link Connecting		As Req'd
14	P20204 (10 Ft.)	<b>CHAIN, 6" FLAT FEED TRACK</b>	Alt. part for 8" MH before 11/99.	As Req'd <sup>1</sup>
	079271 (1 Ft.)	Chain, Flat Feed, 6 X 1Foot Long w/pin		As Req'd
	022424	Pin, Track Link Connecting		As Req'd

REF	PART #	DESCRIPTION	COMMENTS	QTY.
15		<b>FEED TRACK NYLON PADS</b> ( <i>See Section 3.4</i> )		
16	F05005-207	<b>BOLT, 1/4-20 X 3/4" HEX HEAD W/WASHER&amp;PATCH</b>		As Req'd
17	S22425	<b>SHAFT, FEED TRACK IDLE</b>		1
	S20285	<b>SHAFT, FEED TRACK IDLE (6" TRACK)</b>	Alt. part for 8" MH before 11/99.	1
18	S20282	<b>PULLEY, FEED TRACK IDLE</b>		1
19	S20286	<b>BUSHING, FEED TRACK IDLE</b>		1
20	P11035	<b>BEARING, 6206-2RS</b>		2
21	F04254-12	<b>RING, 62MM INTERIOR RETAINING</b>		1
22	F05007-68	<b>SCREW, 3/8-16 X 3/8" CUP POINT SET</b>		2
23	038090	<b>COLLAR, LOCKING</b>		1
24	F05007-1	<b>BOLT, 3/8-16 X 3" HEX HEAD FULL THREAD</b>		2
25	F05010-1	<b>NUT, 3/8-16 HEX</b>		2
	A22649-12	<b>SAWDUST ELIMINATION KIT</b>		1
	A22373	<b>SAWDUST ELIMINATION KIT (8")</b>	Order retrofit kit A22373 for 8" MultiHeads not originally equipped with sawdust elimination kit. Replaces A22649.	1
26	W22641	Rake, Feed Tube Sawdust		1
27	W22644	Scraper, Feed Track Drive Sprocket		1
28	F05005-1	Bolt, 1/4-20 x 3/4" Hex Head Full Thread		2
29	F05011-14	Washer, 1/4" Split Lock		2
30	F05011-11	Washer, 1/4" SAE Flat		2
31	W22652-12	Scraper, 12" Feed Track Idle Pulley		1
	W22652	Scraper, 8" Feed Track Idle Pulley	Alt. part for 8" MH before 11/99.	1
32	F05005-81	Bolt, 1/4-20 x 1 1/4" 'U'		2
33	F05010-9	Nut, 1/4-20 Self-Locking Hex		4
34	S22426	Chain, Modified 7.5" Flat Feed Track		1
	S22647	Chain, Modified 6" Flat Feed Track	Alt. part for 8" MH before 11/99.	1
	A22373-440	Instruction Sheet, Sawdust Elimination Kit		1
35	F05010-10	<b>NUT, 3/8-16 HEX NYLON LOCK</b>		8
36	S22085	<b>BRACKET, OFF-LOAD TABLE MOUNT</b>		1
37	W22438	<b>PLATE WELDMENT, OFF-LOAD TABLE</b>		1
38	S22218	<b>BRACKET, OFF-LOAD TABLE SUPPORT</b>		1
39	S20040	<b>DECAL, HAND SAFETY DANGER</b>		6





### 3.4 Feed Track Nylon Pads

Model	1/2" x 2 3/4" Nylon Pads See Qty. Below to replace entire set of track pads <sup>1</sup>	
	S22781 (60")	S22782 (56")
MH1D12	4	--
MH2D12	4	--
MH3D12	4	2
MH4D12	4	2
MH5D12	4	4

<sup>1</sup> 022117, 022118 & 022119 single-length strips no longer available. All pads should be replaced in complete sets.

### 3.5 Feed Roller Assembly (Non-Air)

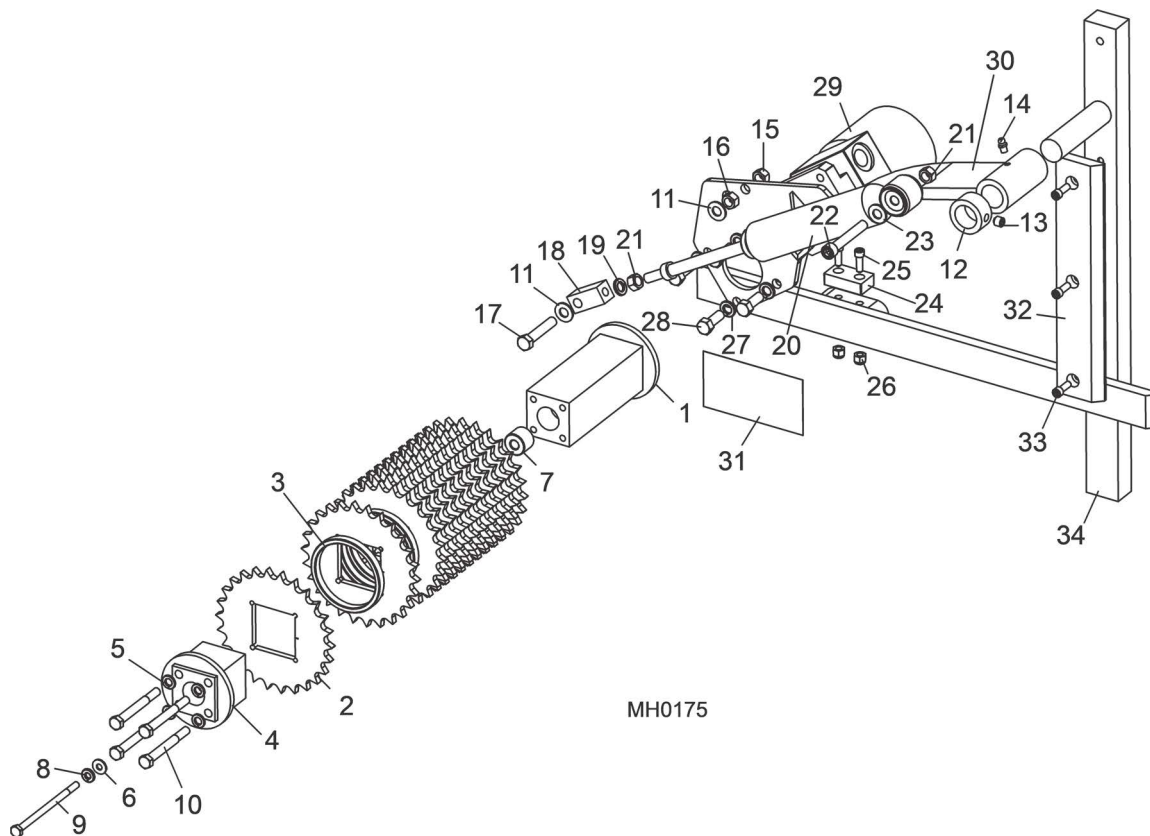

REF	PART #	DESCRIPTION	COMMENTS	QTY.
	A22486-12	<b>FEED ROLLER ASSEMBLY, 12" MULTIHEAD</b>		1
1	W22485	Shaft Weldment, Feed Roller	Available in assemblies only.	1
2	S22480	Sprocket, Feed Roller Square Shaft		13
	016530	Sprocket, Smooth Feed Roller Square Shaft		13
3	S22481	Ring, Sprocket Spacer		12
4	W22485-12	Shaft Extension Weldment, Feed Roller	Available in assemblies only.	1
5	F05011-13	Washer, 5/16" Split Lock		4
6	F05011-11	Washer, 1/4" SAE Flat		1
7	S22487	Spacer, Feed Roller Shaft		1
8	F05011-14	Washer, 1/4" Split Lock		1
9	F05005-76	Bolt, 1/4-20 x 4 1/2" Hex Head Grade 5		1
10	F05006-62	Bolt, 5/16-18 x 3" Hex Head Grade 5		4
	S22488	<b>HANDLE, FEED ROLLER LIFT</b>	Available in assemblies only.	2/machine
11	F05011-3	<b>WASHER, 3/8" SAE FLAT</b>		2
12	038090	<b>COLLAR, FEED ROLLER LOCKING</b>		1
13	F05007-68	<b>SCREW, 3/8-16 X 3/8" CUP POINT SET</b>		1
14	P05060	<b>FITTING, 1/4-28 GREASE</b>		1
15	F05010-1	<b>NUT, 3/8-16 HEX</b>		1
16	F05010-25	<b>NUT, 3/8-16 HEX LOCK</b>		1
17	F05007-16	<b>BOLT, 3/8-16 X 2" HEX HEAD FULL THREAD</b>		1
	A22699	<b>SHOCK ASSEMBLY, FEED ROLLER</b>		1
18	S20163	Block, Feed Roller Piston Pivot		1

REF	PART #	DESCRIPTION	COMMENTS	QTY.
19	F05011-4	Washer, 3/8" Split Lock		1
20	P20263	Shock, Feed Roller J550 Gas w/Bushing Pak 148 (P20263-1)		1
21	F05010-1	Nut, 3/8-16 Hex		2
22	F05007-24	Bolt, 3/8-16 X 2 1/2" Socket Head		1
23	F05011-3	Washer, 3/8" SAE Flat		1
24	038898	<b>BUMPER, FEED ROLLER</b>		1
25	F05006-26	<b>BOLT, 1/4-20 X 3/4" SOCKET HEAD</b>		2
26	F05010-69	<b>NUT, 1/4-20 HEX NYLON LOCK</b>		2
27	F05011-4	<b>WASHER, 3/8" SPLIT LOCK</b>		4
28	F05007-7	<b>BOLT, 3/8-16 X 1" HEX HEAD</b>		4
29	P20206	<b>MOTOR, MG10-13-10AAAB HYDRAULIC</b>		1
30	W22113-1	<b>ARM, FEED ROLLER MOUNT</b>		1
31	S20040	<b>DECAL, HAND SAFETY DANGER</b>		1
32	033400	<b>PAD, POST SLIDE</b>		1
33	F05005-26	<b>SCREW, 1/4-20 X 3/4" SOCKET HEAD</b>		3
34	W22023-1	<b>POST WELDMENT, MODIFIED UPRIGHT</b>		1

### 3.6 Feed Roller Assembly (Air-Lift)

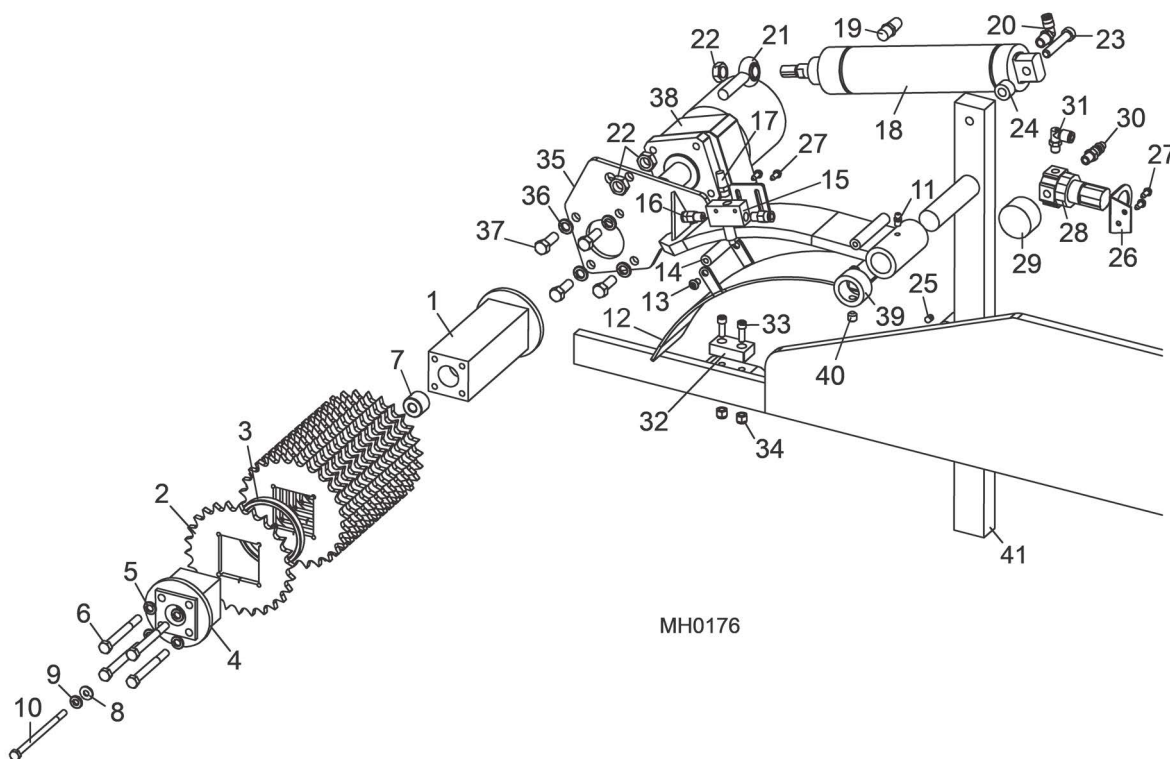

MH0176

REF	PART #	DESCRIPTION	COMMENTS	QTY.
	A22486-12	<b>FEED ROLLER ASSEMBLY, 12" MULTIHEAD</b>		1
1	W22485	Shaft Weldment, Feed Roller	Available in assemblies only.	1
2	S22480	Sprocket, Feed Roller Square Shaft		13
	016530	Sprocket, Smooth Feed Roller Square Shaft		13
3	S22481	Ring, Sprocket Spacer		12
4	W22485-12	Shaft Extension Weldment, Feed Roller	Available in assemblies only.	1
5	F05011-13	Washer, 5/16" Split Lock		4
6	F05006-62	Bolt, 5/16-18 x 3" Hex Head Grade 5		4
7	S22487	Spacer, Feed Roller Shaft		1
8	F05011-11	Washer, 1/4" SAE Flat		1
9	F05011-14	Washer, 1/4" Split Lock		1
10	F05005-76	Bolt, 1/4-20 x 4 1/2" Hex Head Grade 5		1
	S22488	<b>HANDLE, FEED ROLLER LIFT</b>	Available in assemblies only.	2/machine
11	P05060	<b>FITTING, 1/4-28 GREASE</b>		1
12	S22189	<b>BRACKET, AIR LIFT FEED ROLLER ACTUATOR</b>		1
13	F05005-62	<b>SCREW, 1/4-20 X 3/8" BUTTON HEAD</b>		4
14	S20786	<b>ROLLER, FEED ROLLER STOP</b>		1
15	P20900	<b>SWITCH, FEED ROLLER AIR</b>		1
16	P03078	<b>FITTING, 1/4" NPT - 1/4" TUBE STRAIGHT</b>		2
17	P20902	<b>MUFFLER, 1/8" NPT AIR</b>		1
	R01869	<b>TUBE, 1/4" AIR</b>		16.5 Ft.
18	P20901	<b>CYLINDER, 4DP6 AIR</b>		1

REF	PART #	DESCRIPTION	COMMENTS	QTY.
19	P20904	MUFFLER, 1/4" NPT AIR		1
20	P21519	FITTING, 1/4" NPT - 1/4" TUBE ELBOW		1
21	P09137	END, 1/2-20 ROD		1
22	F05010-16	NUT, 1/2-20 HEX JAM		3
23	S20793	PIN, FEED ROLLER AIR CYLINDER PIVOT		1
24	S22625	SPACER, AIR CYLINDER MOUNT		1
25	F05005-47	SCREW, 1/4-20 X 3/8" CUP POINT SET		1
26	P20799	BRACKET, AIR REGULATOR MOUNT		1
27	F05015-18	SCREW, 1/8-32 X 1/2" SLOTTED HEX		4
28	P02765	REGULATOR, 300 PSI AIR FLOW		1
29	P02766	GAUGE, 160 PSI AIR		1
30	P22681	FITTING, 1/8" NPT MALE COUPLING		1
31	P09736	FITTING, 1/8" NPT - 1/4" TUBE 90° ELBOW		1
32	038898	BUMPER, FEED ROLLER		1
33	F05006-26	BOLT, 1/4-20 X 3/4" SOCKET HEAD		2
34	F05010-69	NUT, 1/4-20 HEX NYLON LOCK		2
35	W22113	ARM, FEED ROLLER MOUNT		1
	S20040	DECAL, HANDS CLEAR WARNING		1
36	F05011-4	WASHER, 3/8" SPLIT LOCK		4
37	F05007-7	BOLT, 3/8-16 X 1" HEX HEAD		4
38	P20206	MOTOR, MG10-13-10AAAB HYDRAULIC		1
39	038090	COLLAR, FEED ROLLER LOCKING		1
40	F05007-68	SCREW, 3/8-16 X 3/8" CUP POINT SET		1
41	W22023-1	POST WELDMENT, MODIFIED UPRIGHT		1

### 3.7 Hydraulic Tank Assembly

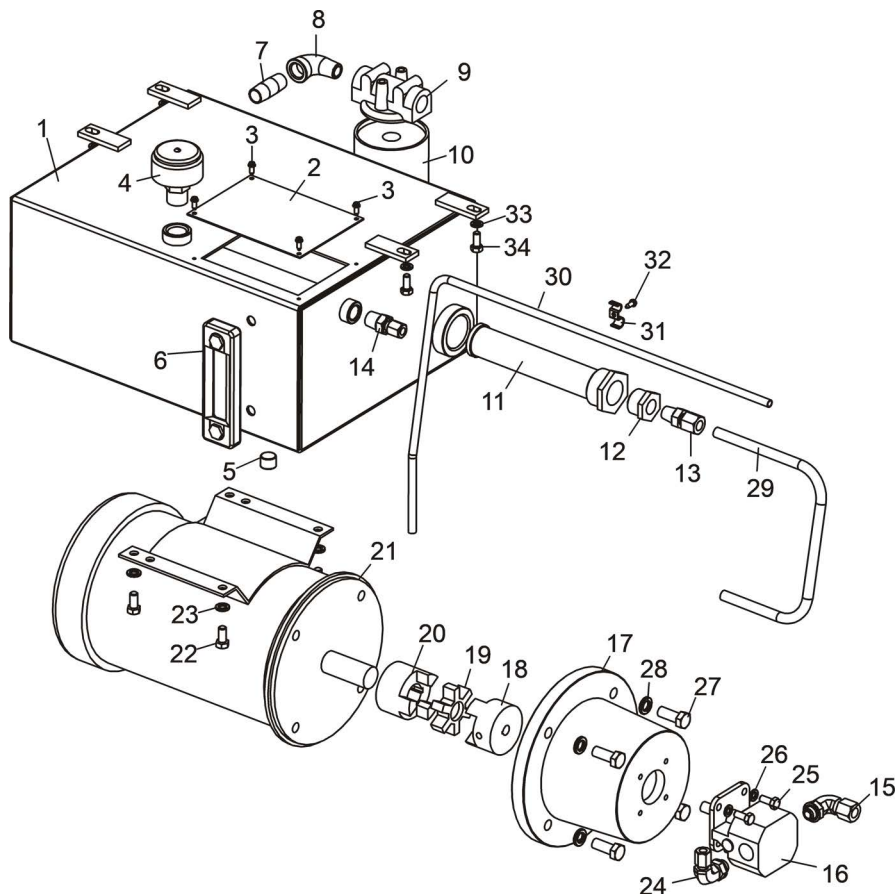

MH0248-1

REF	PART #	DESCRIPTION	COMMENTS	QTY.
	065489	<b>TANK ASSEMBLY, HR/MGR HYDRAULIC</b>		1
	006397	Fluid, Conoco MV32 All Weather Hydraulic (1 Gallon)		8
<b>1</b>	065490	Tank Weldment, Hydraulic Fluid		1
<b>2</b>	S20331	Lid, Hydraulic Fluid Tank Access		1
<b>3</b>	F05015-18	Screw, #8-32 x 1/2" Slotted Hex Head		4
<b>4</b>	P20212	Cap, Hydraulic Tank Fill/Breather		1
<b>5</b>	P26258	Fitting, 1/2" NPT Male Plug		1
<b>6</b>	P20211	Gauge, Hydraulic Fluid Level Sight		1
<b>7</b>	016844	Fitting, 1/2" NPT x 2" Long Nipple		1
<b>8</b>	P22684	Fitting, 1/2" NPT 90° Elbow		1
<b>9</b>	P22683	Manifold, Hydraulic Cartridge Filter		1
<b>10</b>	P20301	Filter, S28 Hydraulic Cartridge		1
<b>11</b>	P20210	Filter, Hydraulic Tank Suction		1
<b>12</b>	P20239	Fitting, 1" NPT - 1/2" NPT Reducer		1
<b>13</b>	P20243	Fitting, 1/2" NPT - 1/2" Tube		1
<b>14</b>	P20242	Fitting, 1/2" NPT - 3/8" Tube Straight		1
<b>15</b>	P20245	Fitting, 1/2" Tube - 1/2" O-Ring 90° Elbow		1
<b>16</b>	P20213	Pump, Hydraulic		1
<b>17</b>	065484	Adaptor, Hydraulic Pump/Motor		1
<b>18</b>	065482	Coupler, L099 x 1/2" Shaft		1

REF	PART #	DESCRIPTION	COMMENTS	QTY.
19	042779	Coupler, L100 Spider		1
20	065483	Coupler, L100 x 1 1/8" Shaft		1
21	065479	Motor, 5HP 3PH 3450RPM Baldor		1
22	F05007-118	Bolt, 3/8-16 x 3/4" Hex Head Grade 5		4
23	F05011-4	Washer, 3/8" Split Lock		4
24	P20244	Fitting, 1/2" O-Ring - 3/8" Tube 90° Elbow		1
25	F05006-102	Bolt, 5/16-18 x 3/4" Hex Head Grade 5		4
26	F05011-13	Washer, 5/16" Split Lock		4
27	F05008-37	Bolt, 1/2-13 x 1 1/4" Hex Head Grade 5		4
28	F05011-9	Washer, 1/2" Split Lock		4
29	R01629	<b>TUBE, 1/2" HYDRAULIC</b>		As Req'd
30	R01628	<b>TUBE, 3/8" HYDRAULIC</b>		As Req'd
31	S02845	<b>CLAMP, 1/2" X 3/8" HOSE</b>		As Req'd
32	F05015-18	<b>BOLT, #8-32 X 1/2 SLOTTED HEX HEAD</b>		As Req'd

### 3.8 Hydraulic Valve Assembly (2 and 4-Head)

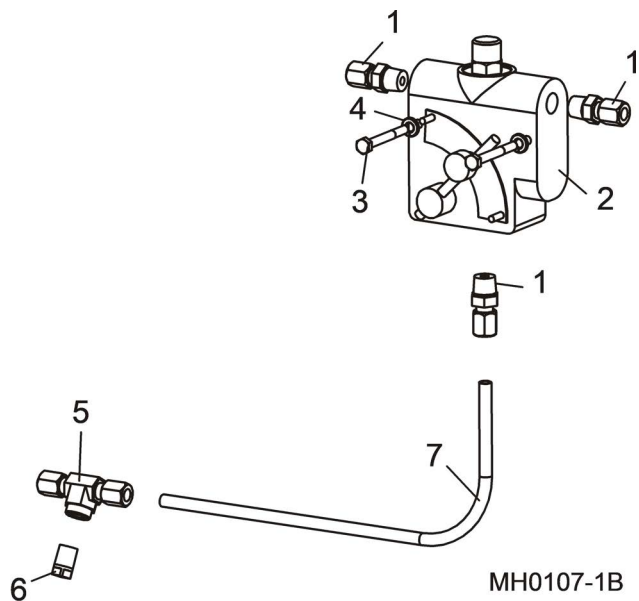

REF	PART #	DESCRIPTION	COMMENTS	QTY.
1	P20744	FITTING, 3/8" TUBE - 3/8" NPT STRAIGHT		3
2	P20743	VALVE, HYDRAULIC FLOW CONTROL		1
3	F05005-72	BOLT, 1/4-20 X 2 1/2" HEX HEAD		2
4	F05011-14	WASHER, 1/4" SPLIT LOCK		2
5	P20345	FITTING, 3/8" TUBE - 1/4" NPT - 3/8" TUBE 'T'		1
6	P05498	PLUG, 1/4" NPT PIPE		1
7	R01628	TUBE, 3/8" HYDRAULIC		As Req'd



### 3.9 Hydraulic Valve Assembly (6-Head)

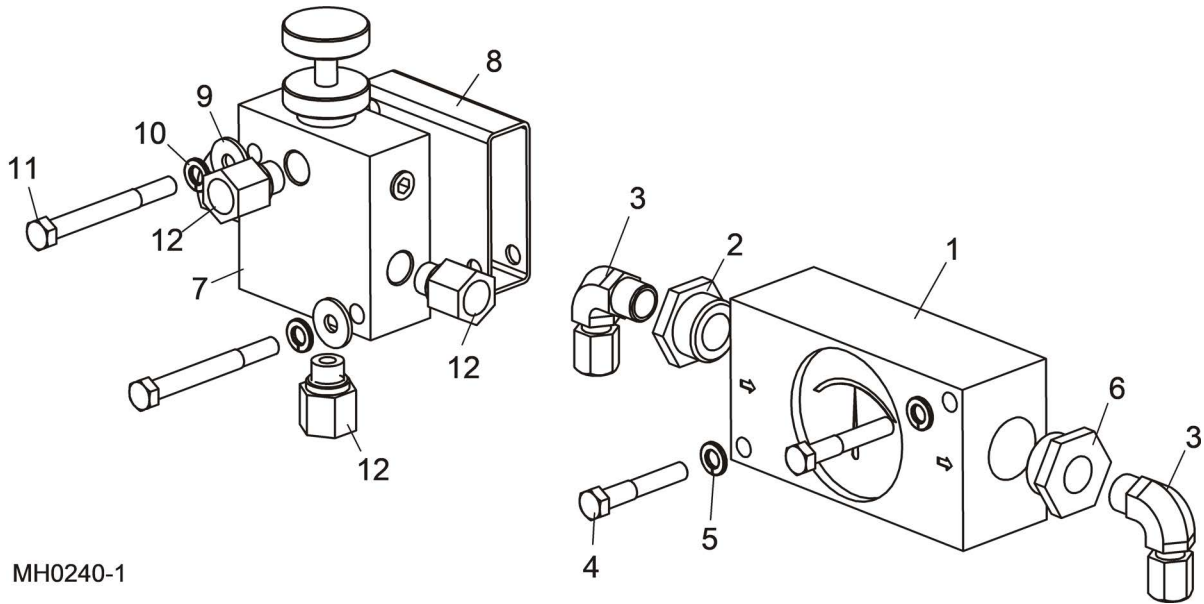

REF	PART #	DESCRIPTION	COMMENTS	QTY.
1	033414	METER, FLOW		1
2	033418	BUSHING, 3/4" MPT X 3/8" FPT		1
3	033416	FITTING, 3/8" MPT X 3/8" TUBE 90°		2
4	F05006-79	BOLT, 5/16-18 X 2" HEX HEAD GRADE 5		2
5	F05011-13	WASHER, 5/16" SPLIT LOCK		2
6	038742	BUSHING, 3/4" MNPT X 1/2" FNPT PIPE		1
	006486	VALVE ASSEMBLY, 6-HEAD/MGR FLOW CONTROL		1
7	033413	Valve, 6-head Merry-Go-Round Flow Control	Available in assemblies only.	1
8	006064	Spacer, MultiHead Flow Control Valve		1
9	F05011-16	Washer, 5/16" Standard Flat		2
10	F05011-13	Washer, 5/16" Split Lock		2
11	F05006-62	Bolt, 5/16-18 x 3" Hex Head Grade 5		2
12	006487	Fitting, 3/8" SAE x 3/8" NPT Adaptor		3

### 3.10 Crowder Fence Assembly

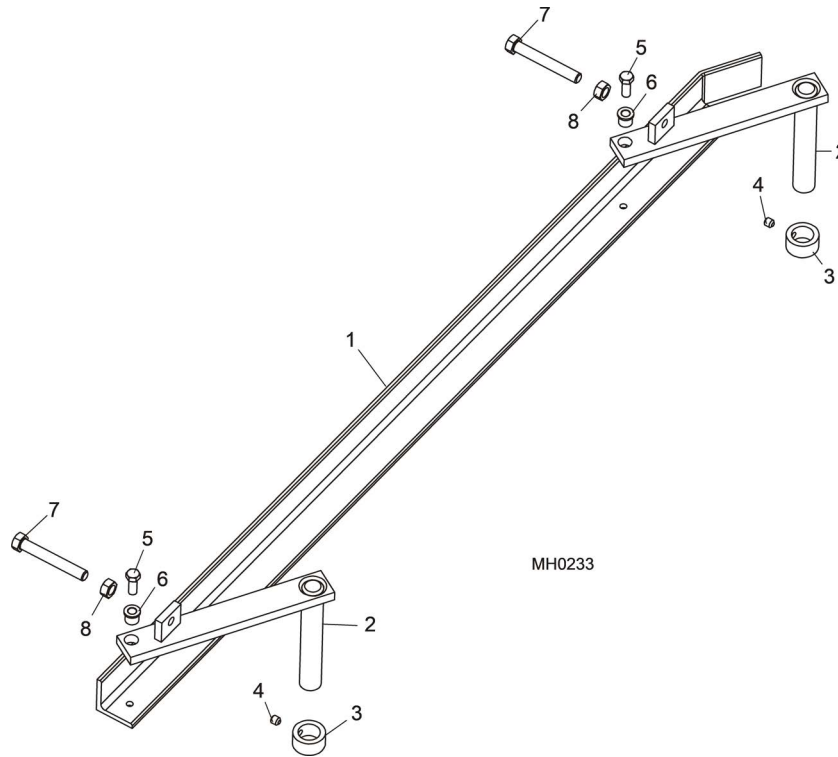

REF	PART #	DESCRIPTION	COMMENTS	QTY.
1	S22260	FENCE, FEED CROWDER		1
2	036338	BRACKET, CROWDER FENCE PIVOT END		2
3	038090	COLLAR, LOCKING		2
4	F05007-68	SCREW, 3/8-16 X 3/8" CUP POINT SET		2
5	F05007-185	BOLT, 3/8-16 X 7/8" HEX HEAD GRADE 5		2
6	036336	BUSHING, 3/4" X .505" FLANGED		2
7	F05008-11	BOLT, 1/2-13 X 3 1/2" HEX HEAD FULL THREAD		2
8	F05010-35	NUT, 1/2-13 HEX		2

### 3.11 Control Box Decals

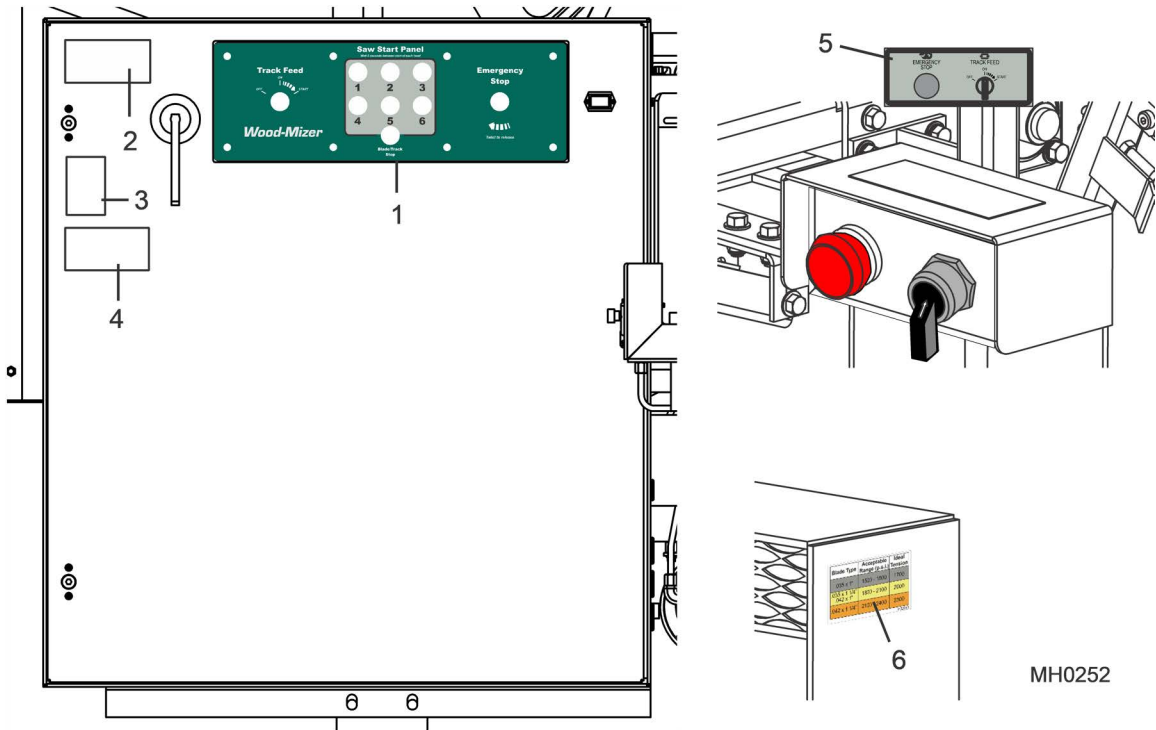

REF	PART #	DESCRIPTION	COMMENTS	QTY.
1	052282	DECAL, 2-HEAD 2005 CONTROL		1
	052283	DECAL, 4-HEAD 2005 CONTROL		1
	052284	DECAL, 6-HEAD 2005 CONTROL		1
2	S20061	DECAL, ELECTRICAL HAZARD DANGER		1
3	S11753	DECAL, EYE/EAR PROTECTION		1
4	016402	DECAL, READ MANUAL WARNING		1
5	052285	DECAL, MULTIHEAD REMOTE BOX		1
6	P22653	DECAL, BLADE TENSION		1

### 3.12 Parts Kit

REF	PART #	DESCRIPTION	COMMENTS	QTY.
1	016445	<b>PARTS KIT, HR1000</b>		
2	128300	Belt, 5VFL1320		1
3	033391	Belt, 5VX1080		2
4	052355	Wear Pad, 1.25 Blade Guide		4
5	K07079	Bearing Kit, Blade Guide Rebuild		2
6	P20301	Filter, S28 Hyd		1
7	A04925	Roller Assy, BG 1-1/4" and 1-1/2" Blades		2
8	061227	Kit, Blade Wheel Bearing		2
9	045208	Bearing, Inner		1
10	045209	Race, Inner Bearing		1
11	045210	Bearing, Outer		1
12	045211	Race, Outer Bearing		1
13	045212	Seal, Blade Wheel		1

REF	PART #	DESCRIPTION	COMMENTS	QTY.
1	016442	<b>PARTS KIT, MULTIHEAD 2 HEAD</b>		
2	128300	Belt, 5VFL1320		2
3	033391	Belt, 5VX1080		2
4	052355	Wear Pad, 1.25 Blade Guide		4
5	K07079	Bearing Kit, Blade Guide Rebuild		2
6	P20301	Filter, S28 Hyd		1
7	A04925	Roller Assy, BG 1-1/4" and 1-1/2" Blades		2
8	A22594	Bearing Kit, MultiHead Hub Replacement		2



---

## B

blade guide

inner 6

outer 9

blade housing cover 17

blade tensioner

block assembly 1

hand pump 1

release handle 3

blade wheel

drive side 14

idle side 16

## D

decals

saw head 19

## F

feed roller

air-lift 10

standard 8

feed track 5

feed track spacers 7

fence 16, 17

## H

hydraulic tank 12

hydraulic valve 14, 15

## P

perimeter fence 2

## S

saw head mount 4

saw motor 5

sawdust chute 18

## U

up/down 12