

DATE	SYM	REVISION RECORD	DR	CK
		CHG. AIR REQ./CHG.AIR INTAKE LOC./ADD WATER INTAKE LOC.		

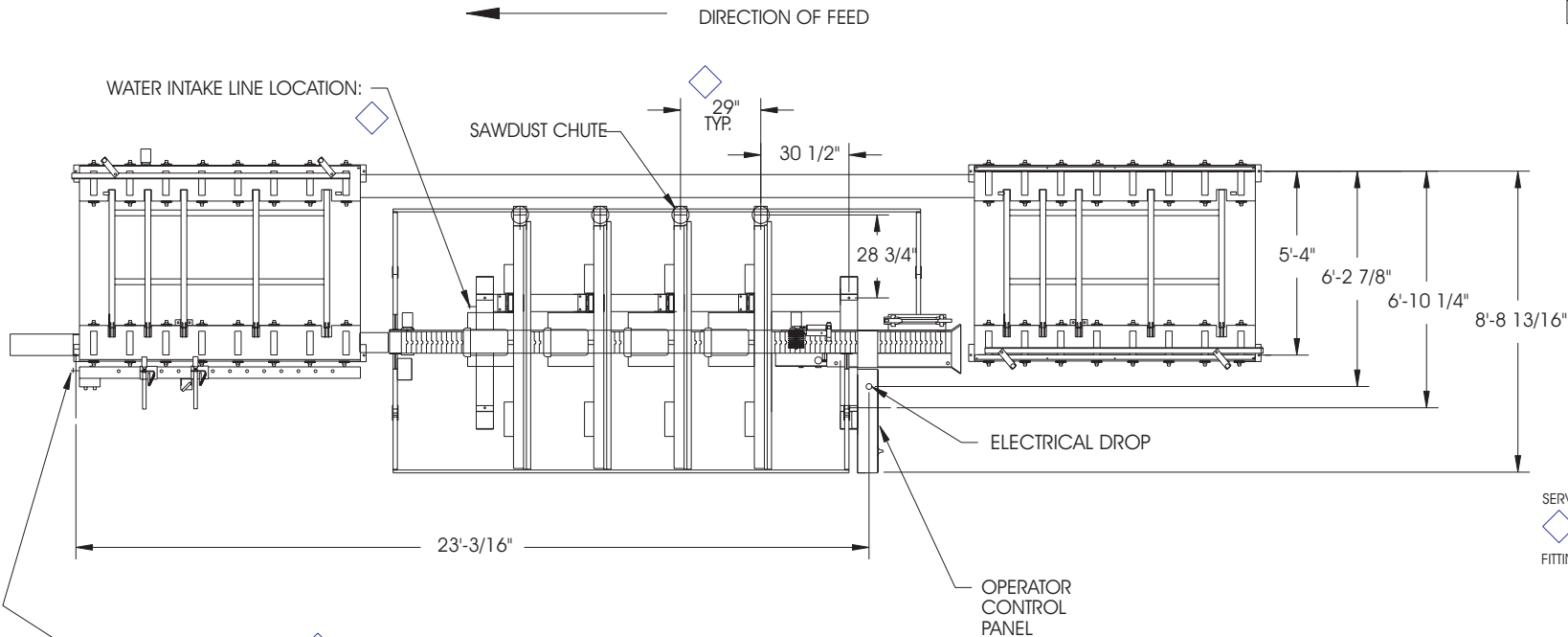

ELECTRICAL REQUIREMENTS				
POWER SUPPLY				REQUIRED AMPS
VOLTS	PH	HZ		
2	208	3	60	225
2	240	3	50/60	200
3	380	3	50	125
1	415	3	50	110
1	460	3	60	100
2	575	3	60	80

1 STANDARD 2 TRANSFORMER REQUIRED
3 TRANSFORMER SUGGESTED

AIR REQUIREMENTS

- SERVICE:
- ◇ VOLUME: 5.0 CFM
 - PRESSURE: 80 PSI (MIN) - 120 PSI (MAX)
- FITTINGS:
- 1/8" NPT (W/O MGR)
 - 1/4" NPT (WITH MGR)

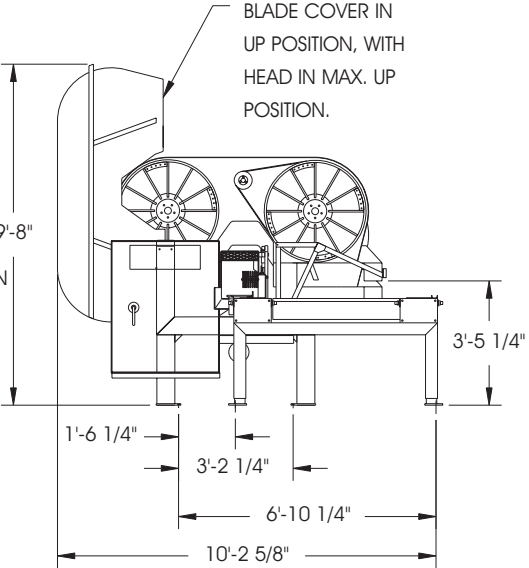
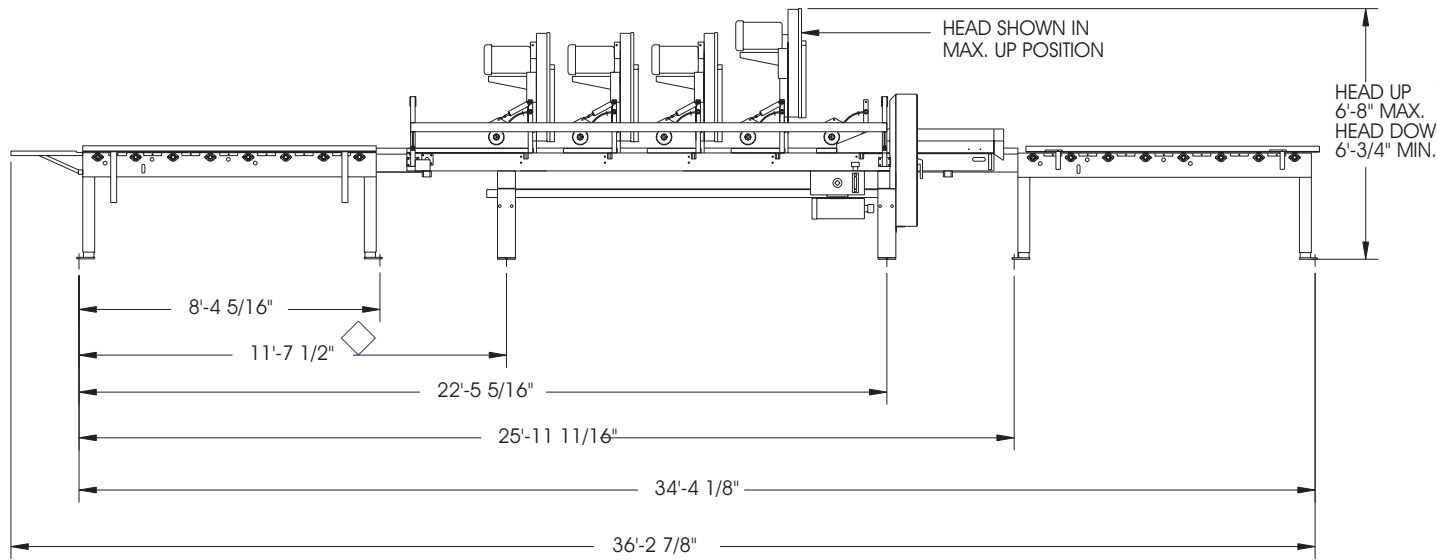

TOLERANCES UNLESS NOTED .XXX + .002 .XX + .008 .X + .015 FRACTIONS + 1/32 ANGLES + .5 DEG	Wood-Mizer Products Inc. <small>6161 W. 10TH ROAD/PO BOX 80 40214-2400 (313) 271-1142 BOX 126, HWY. 46 E. NEW PINE IN 47568 (812) 645-8267</small>		MODEL	SCALE	DATE	DRN BY	CK BY
	MH4R8MGR		DRAWING NO.	REVISION			