

## INDUSTRIAL PRODUCTS

### Electrical Diagrams & Components Lists

---

### MultiHead 25HP 575V Electrical Package

---



**Safety is our #1 concern!** Read and understand all safety information and instructions before operating, setting up or maintaining this machine.

*April 2005*

*Form #961*

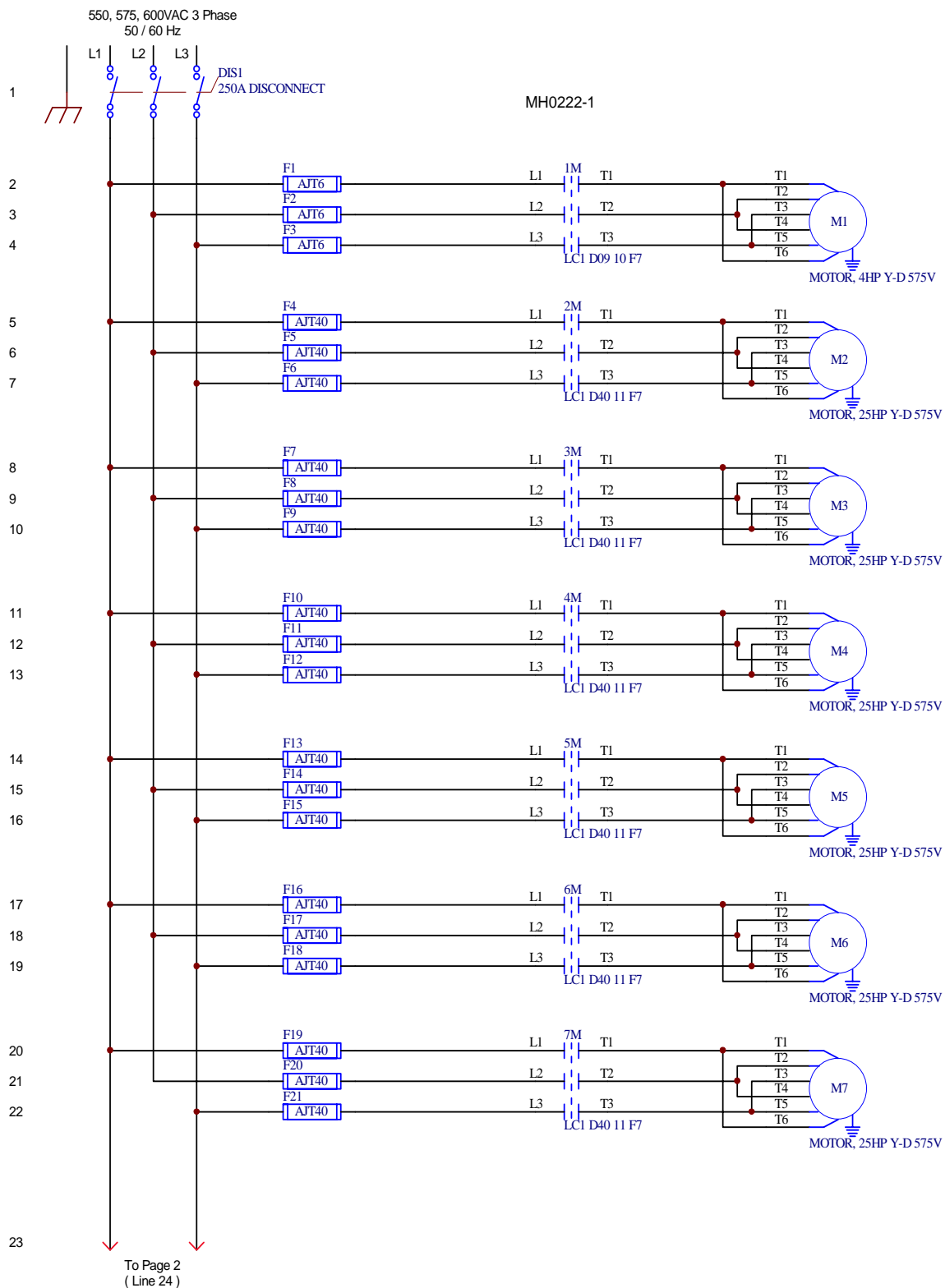

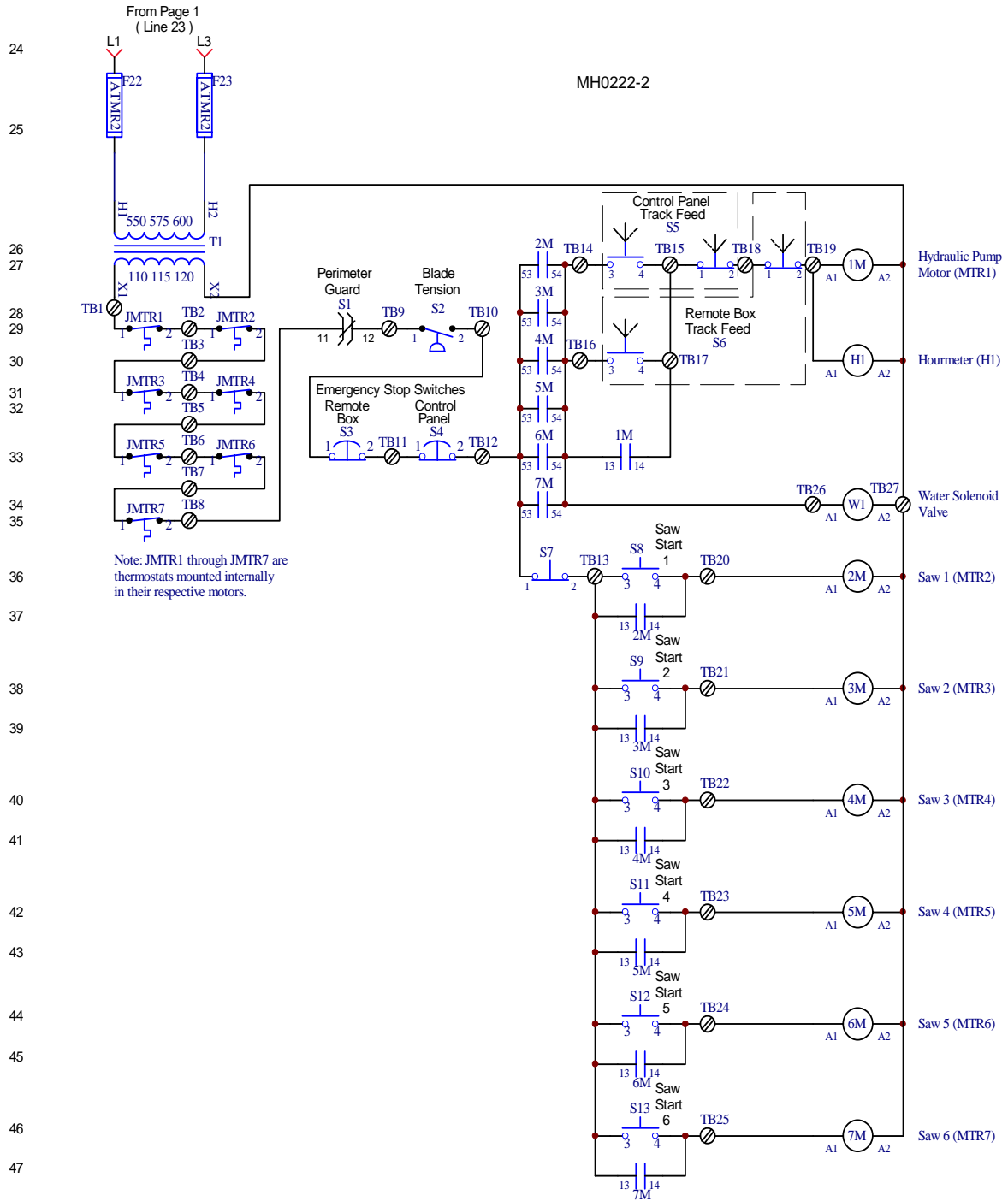

MH0222-3



① Used for M68 Merry Go Round option only.

② Used for Soft Start option only.

**MAIN CONTROL PANEL DIAGRAM**

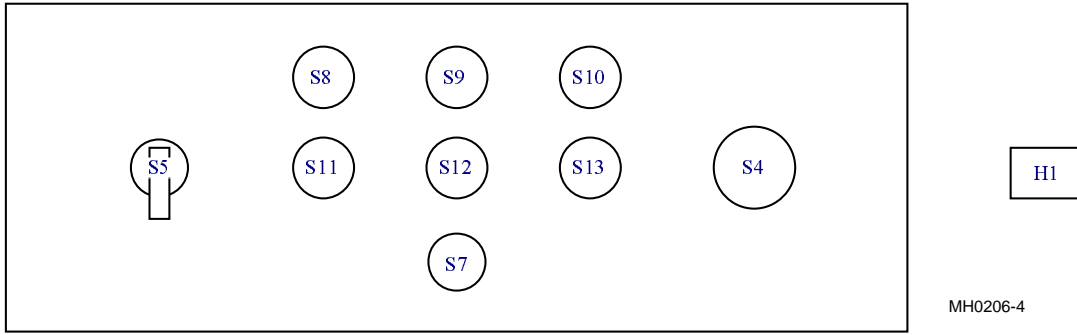

**REMOTE CONTROL PANEL DIAGRAM**

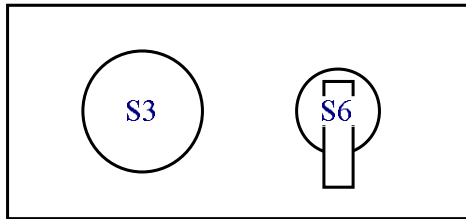

<b>ELECTRICAL COMPONENT LIST</b>				
<b>PART</b>	<b>MFG. PART #</b>	<b>MFG.</b>	<b>AWMV PART #</b>	<b>DESCRIPTION</b>
<b>1M</b>	LC1D0910F7	Telemecanique	E23403	Contacteur, 9 Amp 120VAC Coil 50/60HZ IEC
<b>2M - 7M</b>	LC1D4011F7	Telemecanique	E23293	Contacteur, 40 Amp 120VAC Coil 50/60HZ IEC
	LA1 DN22	Telemecanique	E23408	Block, Auxiliary Contact
<b>MTR1</b>	Custom	Baldor	P22689	Motor, 4HP 575V Custom 3 Phase w/Thermistats
<b>MTR2 - MTR7</b>	LM21074	Lincoln	016022	Motor, 25HP 575V Custom 3 Phase w/Thermistats
<b>DIS1</b>	JGM36000S25	Square D	069357 <sup>1</sup>	Breaker, 600V 250A J-Frame Molded Case
	0421LJ1	Square D	069358	Handle Kit, J-Frame Door-Mounted Rotary
	PDC6JD4	Square D	069359	Lug Kit, J-Frame Breaker Power Distribution
	S37450	Square D	069360	Shield, J-Frame Breaker Long Lug
<b>F1-F3</b>	AJT-6	Gould-Ferraz	E23237	Fuse, 6 Amp 600 Volt Class J
<b>F4-F21</b>	AJT-40	Gould-Ferraz	024789	Fuse, 40 Amp 600 Volt Class J
<b>F22-F23</b>	ATMR-2	Gould-Ferraz	E22716	Fuse, 2 Amp 600 Volt Class CC
<b>H1</b>	T51E2	ENM	024586	Hour Meter, 115V 50/60 Hz
<b>S1</b>	AZ15 ZVR	Schmersal	E22711	Switch, Perimeter Safety
	AZ15/16 B1	Schmersal	E22711-1	Key, Perimeter Safety Switch
<b>S2</b>	9012 GTG-2	Square D	E22726 <sup>2</sup>	Switch, Hydraulic Pressure
<b>S3 &amp; S4 (Two Pieces)</b>	ZB4 BS547	Square D	050551 <sup>3</sup>	Switch Operator, Red Emergency Stop
	ZB4 BZ102	Square D		Switch Contact Block, Emergency Stop (Normally Closed)
<b>S5 &amp; S6 (Two Pieces)</b>	ZB4 BJ87	Square D	050552 <sup>4</sup>	Switch Operator, 3-Position Track Feed
	ZB4 BZ105	Square D		Switch Contact, Track Feed (Normally Open)
<b>S7 (Two Pieces)</b>	ZB4 BL47	Square D	050549 <sup>5</sup>	Switch Operator, Blade/Track Stop
	ZB4 BZ102	Square D		Switch Contact Block, Blade/Track Stop (Normally Closed)
<b>S8 - S13 (Two Pieces)</b>	ZB4 BA37	Square D	050554 <sup>6</sup>	Switch Operator, Saw Head Start
	ZB4 BZ101	Square D		Switch Contact Block, Saw Head Start (Normally Open)
<b>T1</b>	9070T250D5	Square D	P03047	Transformer, 550-575-600/110-115-120 250VA
<b>W1 (Two pieces)</b>	B11-420	Gemline	E22772	Solenoid Valve, 110 VAC 50/60 Hz
			P22514	Nut, Solenoid Valve

<sup>1</sup> Breaker 069357 replaces E20520 originally supplied prior to 3/10 (SquareD discontinued KHL36000MMT). Replacement requires new handle kit 069358, lug kit 069359 and shield 069360.

<sup>2</sup> Switch E22726 changed by manufacturer 4/11. New switch has straight wire connection. Replace fitting on connecting harness with swivel connector 051750.

<sup>3</sup> Telemecanique ZB2 components replaced by Square D ZB4 components 4/02. Kit 050551 replaces E23275 and E23280 originally supplied.

<sup>4</sup> Telemecanique ZB2 components replaced by Square D ZB4 components 4/02. Kit 050552 replaces 024684 and E23388 originally supplied.

<sup>5</sup> Telemecanique ZB2 components replaced by Square D ZB4 components 4/02. Kit 050549 replaces E23272 and E23280 originally supplied.

<sup>6</sup> Telemecanique ZB2 components replaced by Square D ZB4 components 4/02. Kit 050554 replaces E23271 and E23279 originally supplied.