

INDUSTRIAL PRODUCTS

Electrical Diagrams & Components Lists

MultiHead 25HP Electrical Package



Safety is our #1 concern! Read and understand all safety information and instructions before operating, setting up or maintaining this machine.

April 2005

Form #742

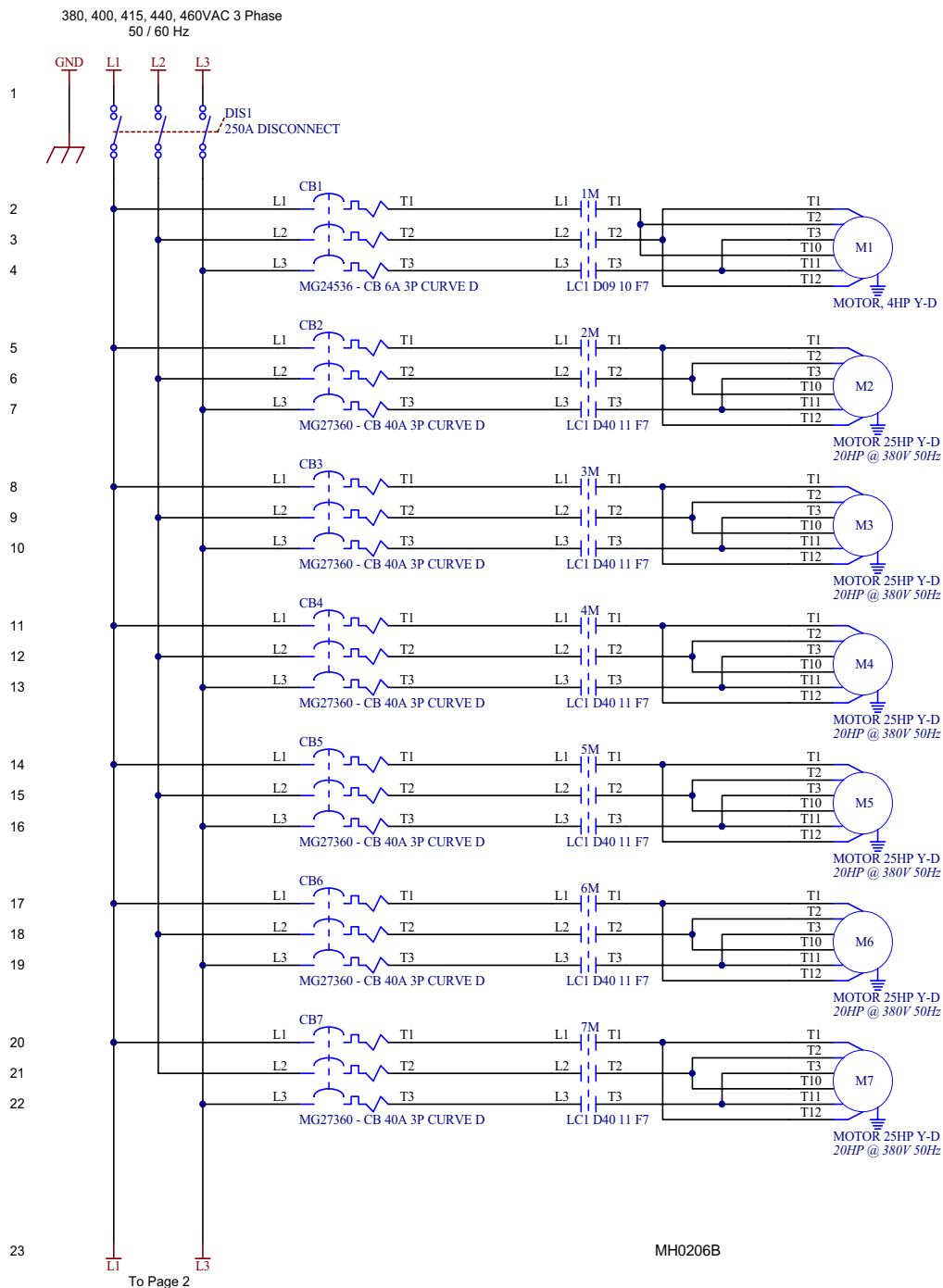

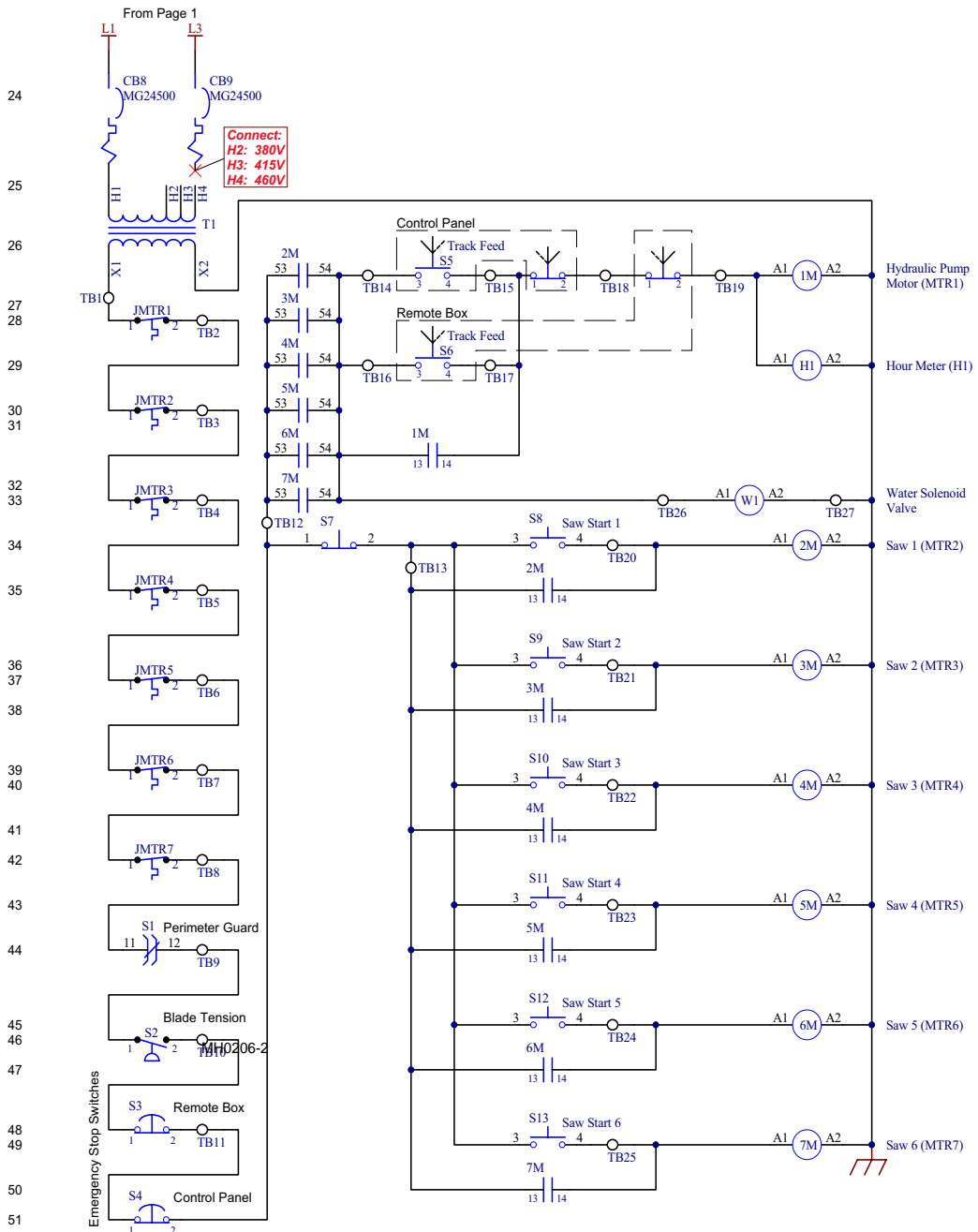

Note: JMTR1 through JMTR7 are thermostats mounted internally in their respective motors.

ELECTRICAL COMPONENT DIAGRAM



① Used for M68 Merry Go Round option only.

② Used for Soft Start option only.

MH0206-3

MAIN CONTROL PANEL DIAGRAM

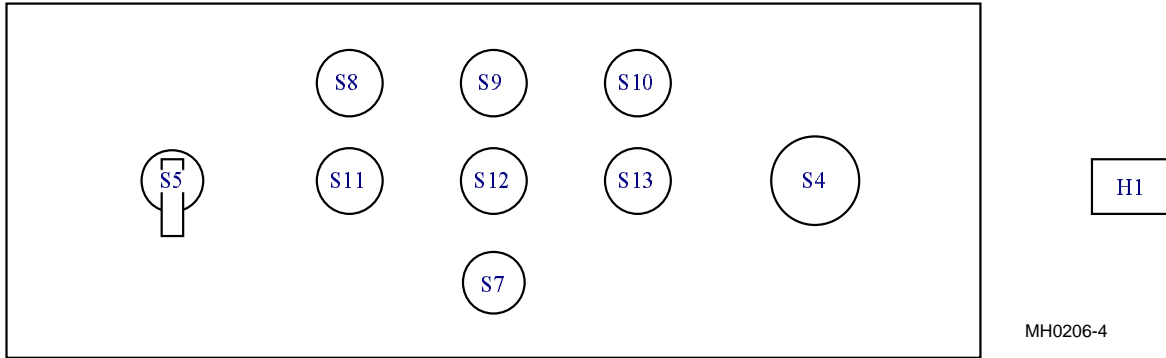

REMOTE CONTROL PANEL DIAGRAM

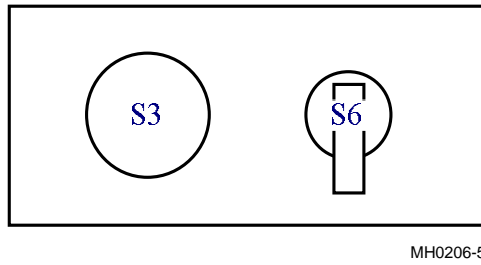

ELECTRICAL COMPONENT LIST				
PART	MFG. PART #	MFG.	AWMV PART #	DESCRIPTION
1M	LC1D0910F7	Telemecanique	E23403	Contactora, 9 Amp 120VAC Coil 50/60HZ IEC
2M - 7M	LC1D40AF7	Telemecanique	053600 ¹	Contactora, 40A 3P 120VAC D-A Series
	LA1 DN22	Telemecanique	E23408	Block, Auxiliary Contact
MTR1	35L432S377	Baldor	P22735 ²	Motor, 4HP Custom 3 Phase w/Thermistats
MTR2 - MTR7	LM17763	Lincoln	021392	Motor, 25HP Custom 3 Phase w/Thermistats
DIS1	JGM36000S25	Square D	069357 ³	Breaker, 600V 250A J-Frame Molded Case
	0421LJ1	Square D	069358	Handle Kit, J-Frame Door-Mounted Rotary
	PDC6JD4	Square D	069359	Lug Kit, J-Frame Breaker Power Distribution
	S37450	Square D	069360	Shield, J-Frame Breaker Long Lug
CB1	MG24536	Square D	024691 ⁴	Circuit Breaker, 6A 480V 3P D-Curve
	MG24537	Square D	050335 ⁴	Circuit Breaker, 8A 480V 3P D-Curve
CB2 - CB7	MG27360	Square D	024690	Circuit Breaker, 40A 480V 3P D-Curve
CB8, CB9	MG24500	Square D	024585	Circuit Breaker, 1A 1P D-Curve
H1	T51E2	ENM	024586	Hour Meter, 115V 50/60 Hz
S1	AZ15 ZVR	Schmersal	E22711 ⁵	Switch, Perimeter Safety
	AZ15/16 B1	Schmersal	E22711-1 ⁵	Key, Perimeter Safety Switch
S2	9012 GTG-2	Square D	E22726 ⁶	Switch, Hydraulic Pressure
S3 & S4 (Two Pieces)	ZB4 BS547	Square D	050551 ⁷	Switch Operator, Red Emergency Stop
	ZB4 BZ102	Square D		Switch Contact Block, Emergency Stop (Normally Closed)
S5 & S6 (Two Pieces)	ZB4 BJ87	Square D	050552 ⁸	Switch Operator, 3-Position Track Feed
	ZB4 BZ105	Square D		Switch Contact, Track Feed (Normally Open)
S7 (Two Pieces)	ZB4 BL47	Square D	050549 ⁹	Switch Operator, Blade/Track Stop
	ZB4 BZ102	Square D		Switch Contact Block, Blade/Track Stop (Normally Closed)
S8 - S13 (Two Pieces)	ZB4 BA37	Square D	050554 ¹⁰	Switch Operator, Saw Head Start
	ZB4 BZ101	Square D		Switch Contact Block, Saw Head Start (Normally Open)
T1	9070T250Q35650	Square D	024696	Transformer, 460-415-380/120 250VA
TB	3004362	Phoenix	024893 ¹¹	Terminal Block, 1 Tier
	3003020	Phoneix	050935 ¹¹	End Cap, Terminal Block
W1 (Two pieces)	B11-420	Gemline	E22772	Solenoid Valve, 110 VAC 50/60 Hz
			P22514	Nut, Solenoid Valve

¹ DIN rail-mount contactor 053600 replaces panel-mount contactor E23293 originally supplied prior to 1/11 due to a change in vendor supply. Replacement of old-style contactor requires DIN rail 024474-3_25, two screws F05015-17 and two clamps E22707. Two 5/32" diameter holes in the mounting panel are required to mount DIN rail.

² Motor available while supplies last. When stock depleted, upgrade to 5HP motor with kit 065492 (Includes Motor, Couplings, Pump Adaptor & Hardware).

³ Breaker 069357 replaces E20520 originally supplied prior to 3/10 (SquareD discontinued KHL36000MMT). Replacement requires new handle kit 069358, lug kit 069359 and shield 069360.

⁴ Use 6A Breaker 024691 for 4HP hydraulic motor originally supplied. Use 8A Breaker 050335 if retrofitted with 5HP motor.

⁵ Switch and Key purchased as two separate parts 3/00.

⁶ Switch E22726 changed by manufacturer 4/11. New switch has straight wire connection. Replace fitting on connecting harness with swivel connector 051750.

⁷ Telemecanique ZB2 components replaced by Square D ZB4 components 4/02. Kit 050551 replaces E23275 and E23280 originally supplied.

⁸ Telemecanique ZB2 components replaced by Square D ZB4 components 4/02. Kit 050552 replaces 024684 and E23388 originally supplied.

⁹ Telemecanique ZB2 components replaced by Square D ZB4 components 4/02. Kit 050549 replaces E23272 and E23280 originally supplied.

¹⁰ Telemecanique ZB2 components replaced by Square D ZB4 components 4/02. Kit 050554 replaces E23271 and E23279 originally supplied.

¹¹ 024893 Terminal Block and 050935 End Cap replace P12220 and P12221 originally supplied prior to 6/03.

