

Wood-Mizer[®] MultiHead

Electrical Diagrams & Components Lists

Domestic 20HP Electrical Package



Safety is our #1 concern! Read and understand all safety information and instructions before operating, setting up or maintaining this machine.

November 1999

Form #709

Incoming Power
460 VAC 3-Phase 50/60 hz

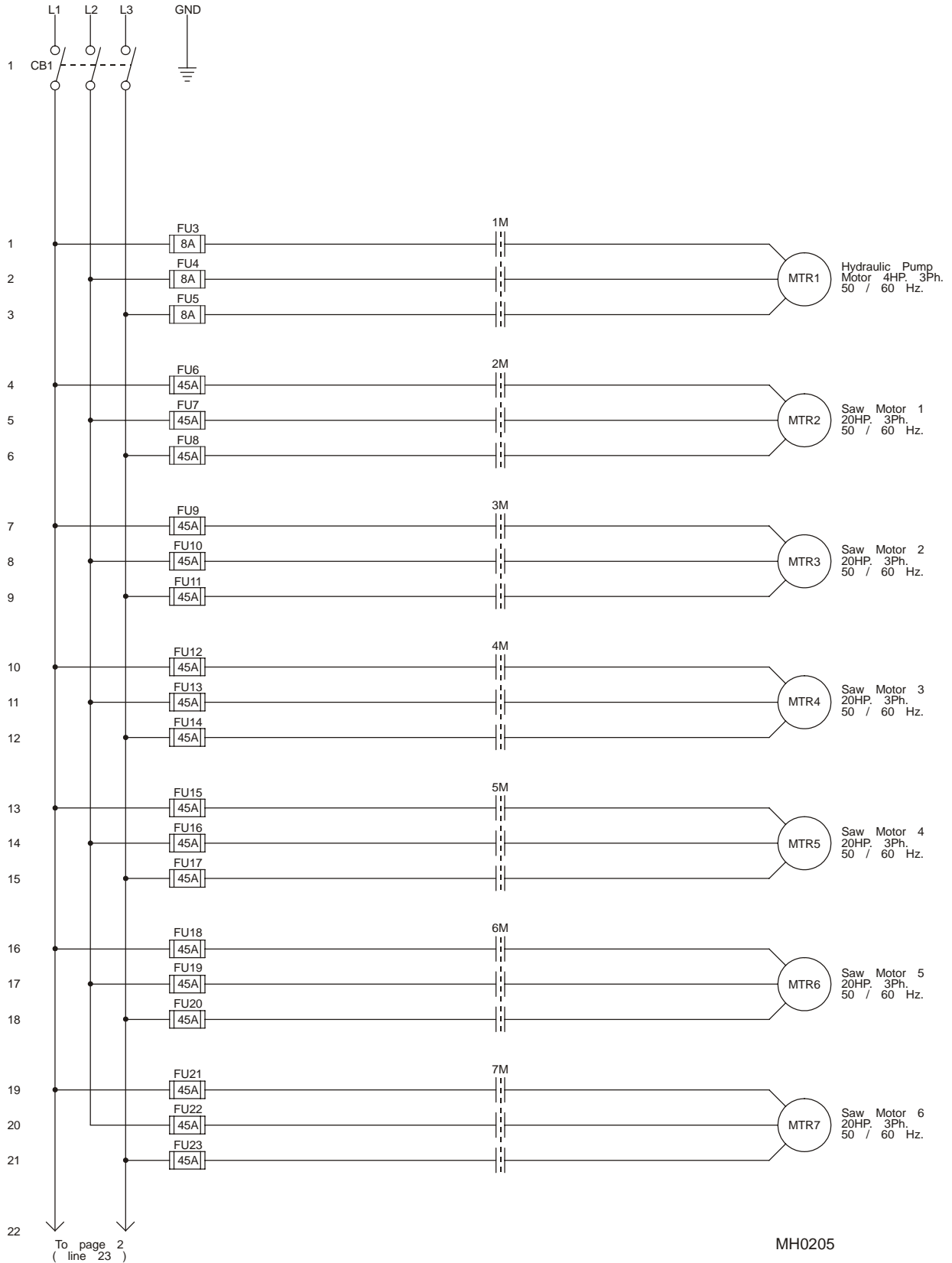

ELECTRICAL DIAGRAM (PAGE 1 OF 2)

From page 1 (line 22)

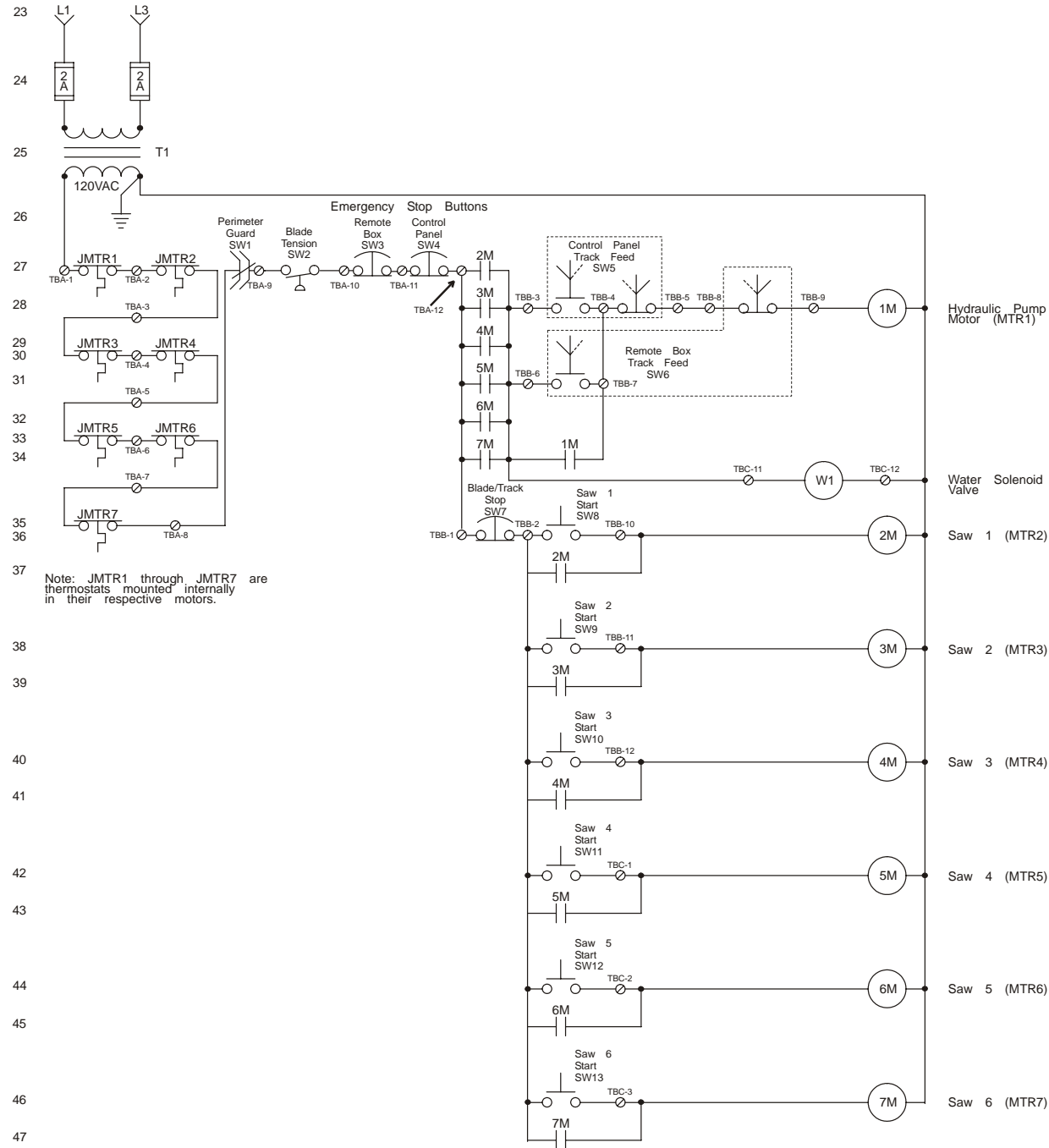

MH0045

ELECTRICAL DIAGRAM (PAGE 2 OF 2)

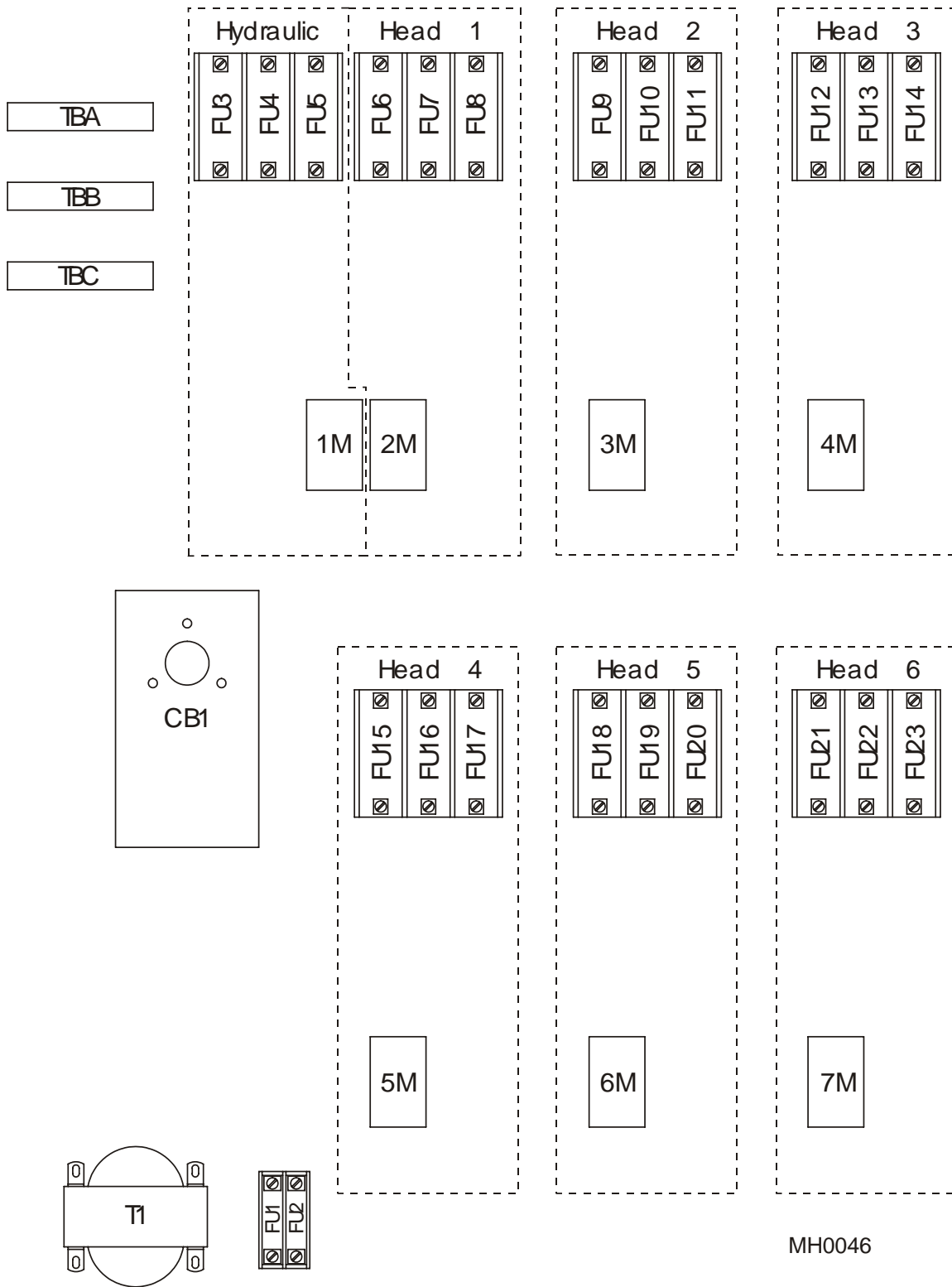

ELECTRICAL COMPONENT DIAGRAM

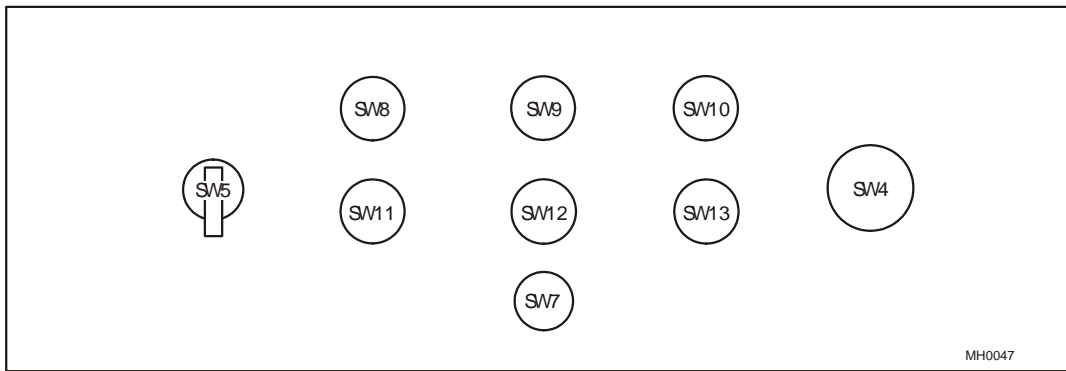

MAIN CONTROL PANEL DIAGRAM

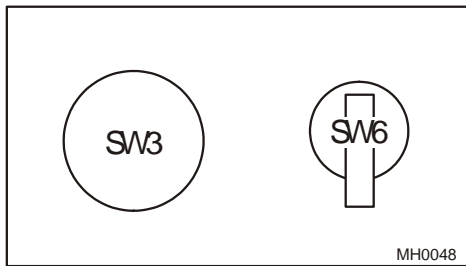

REMOTE CONTROL PANEL DIAGRAM

TBA

MH0049

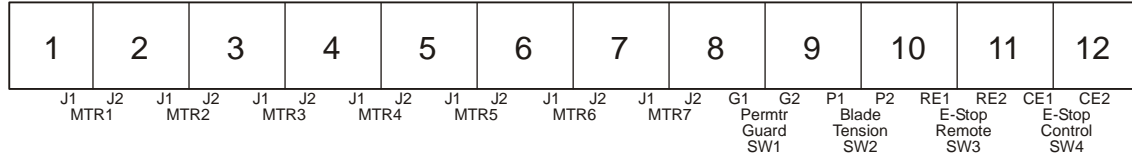

TBB

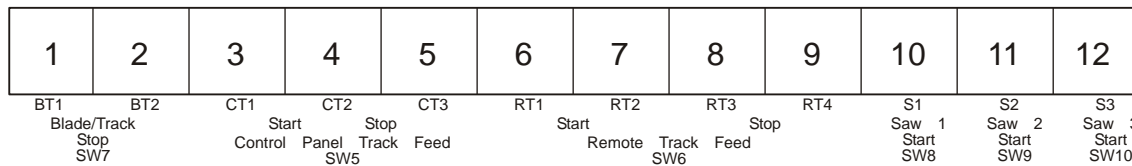

TBC

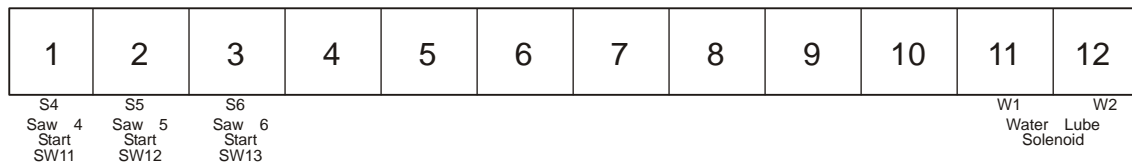

TERMINAL BLOCK DIAGRAM

ELECTRICAL COMPONENT LIST				
PART	MFG. PART #	MFG.	W-M PART #	DESCRIPTION
1M	LC1D0910F7	Telemecanique	E23403	Contact, 9 Amp 120VAC Coil 50/60HZ IEC
2M - 7M	LC1D3210F7	Telemecanique	N/A	Contact
	LA1 DN22	Telemecanique	E23408	Block, Auxiliary Contact
MTR1	35L432S377	Baldor	P22735 ¹	Motor, 4HP Custom 3 Phase w/Thermistats (460 VAC)
	35M405S985G1	Baldor	P22689	Motor, 4HP Custom 3 Phase w/Thermistats (575 VAC)
MTR2 - MTR7	09C106W924G1	Baldor	N/A	Motor, 20HP Custom 3 Phase w/Thermistats (460 VAC)
CB1	FHL36000MMT	Square D	E20523	Disconnect, 100 Amp (1 - 2 Head Saws)
	JGM36000S25	Square D	069357 ²	Breaker, 600V 250A J-Frame Molded Case (3-6 Head Saws)
	0421LJ1	Square D	069358	Handle Kit, J-Frame Door-Mounted Rotary
	PDC6JD4	Square D	069359	Lug Kit, J-Frame Breaker Power Distribution
FU1, FU2	S37450	Square D	069360	Shield, J-Frame Breaker Long Lug
FU3, FU4, FU5	AJT-8	Gould	E22715	Fuse, 8 Amp 600 Volt Class J
FU6 - FU23	AJT-45	Gould	N/A	Fuse, 45 Amp 600 Volt Class J
	60608J	Gould	N/A	Block, 3 Position 600 Volt Class J Fuse
SW1	AZ15 ZVR-K	Schmersal	E22711 ³	Switch, Perimeter Safety
	AZ15/16 B1	Schmersal	E22711-1 ³	Key, Perimeter Safety Switch
SW2	9012 GTG-2	Square D	E22726 ⁴	Switch, Hydraulic Pressure
SW3 & SW4	9001KR9RH13	Square D	052610 ⁵	Switch Assembly, Red Emergency Stop
SW5 & SW6 (Three Pieces)	ZB3 BJ8	Telemecanique	A22775	Switch Operator, 3-Position Track Feed
	ZB2 BE101	Telemecanique		Switch Contact, Track Feed (Normally Open)
	ZB2 BE102	Telemecanique		Switch Contact, Track Feed (Normally Closed)
SW7 (Two Pieces)	9001 KR1U	Square D	E20530	Switch Operator, Blade/Track Stop
	9001 KA3	Square D	E20533	Switch Contact Block, Blade/Track Stop (Normally Closed)
SW8 - SW13 (Two Pieces)	9001 KR1U	Square D	E20530	Switch Operator, Saw Head Start
	9001 KA2	Square D	E20532	Switch Contact Block, Saw Head Start (Normally Open)
T1	9070 K250D1	Square D	P03025	Transformer, 230/460VAC - 120VAC
	9070 K250D5	Square D	P03047	Transformer, 500/575/600 VAC - 125 VAC
TB	3004362	Phoenix	024893 ⁶	Terminal Block, 1 Tier
	3003020	Phoenix	050935 ⁶	End Cap, Terminal Block
W1 (2 pieces)	B11-420	Gemline	E22772	Solenoid Valve, 110 VAC 50/60 Hz
			P22514	Nut, Solenoid Valve

¹ Motor available while supplies last. When stock depleted, upgrade to 5HP motor with kit 065492 (Includes Motor, Couplings, Pump Adaptor & Hardware).

² Breaker 069357 replaces E20520 originally supplied prior to 3/10 (SquareD discontinued KHL36000MMT). Replacement requires new handle kit 069358, lug kit 069359 and shield 069360.

³ Switch and Key purchased as two separate parts 3/00.

⁴ Switch E22726 changed by manufacturer 4/11. New switch has straight wire connection. Replace fitting on connecting harness with swivel connector 051750.

⁵ E-Stop Assembly 052610 replaces Switch Operator E22703 and Contact E22706 supplied prior to 11/05. Operator E22703 discontinued by the vendor and replacement is not interchangeable with contact E22706. Replace entire switch assembly with 052610.

⁶ 024893 Terminal Block and 050935 End Cap replace P12220 and P12221 originally supplied prior to 6/03.