

Electrical Diagrams & Components Lists

HR1000 25HP Electrical Package



Safety is our #1 concern! Read and understand all safety information and instructions before operating, setting up or maintaining this machine.

May 2010

Form #1692

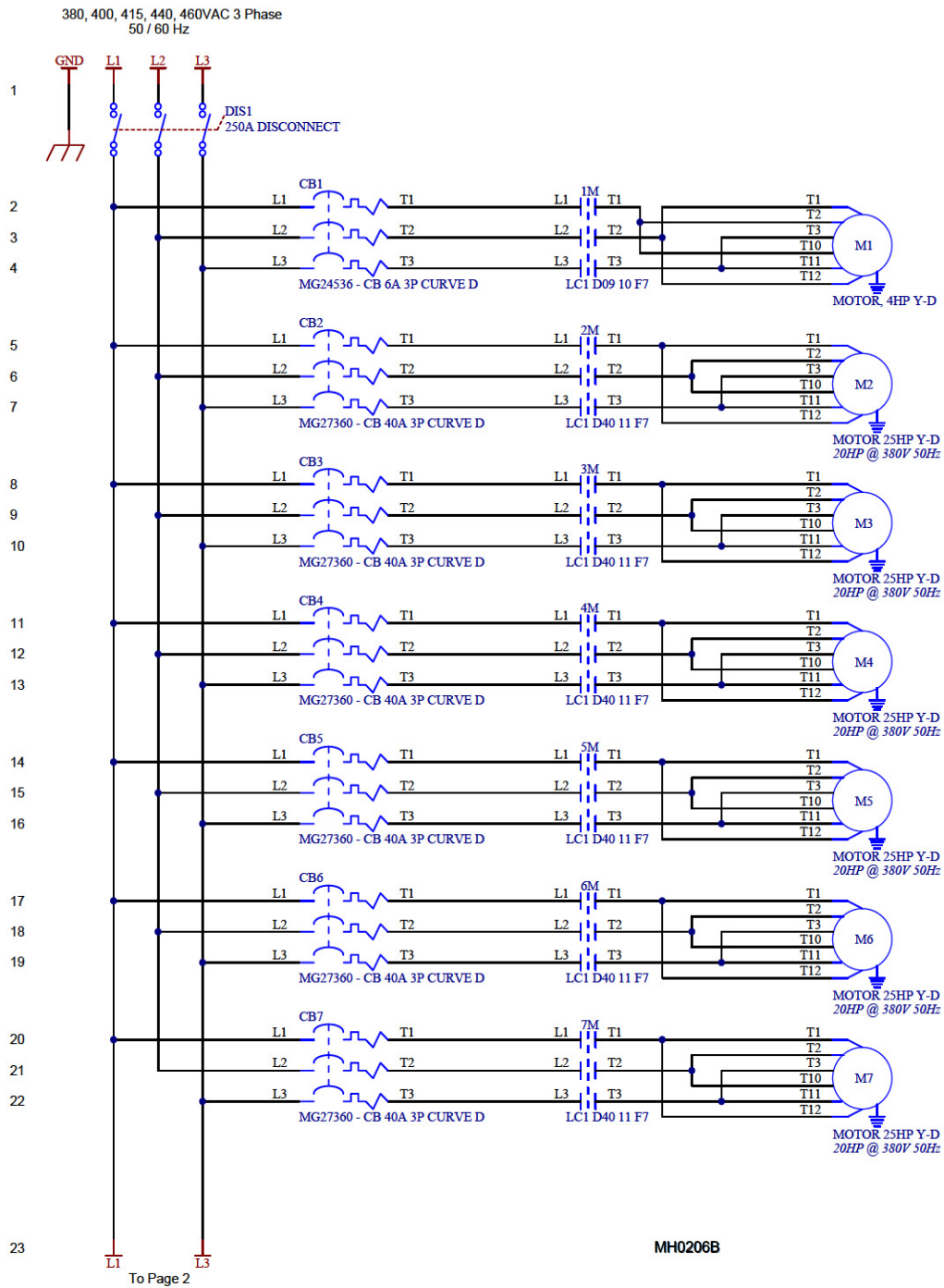

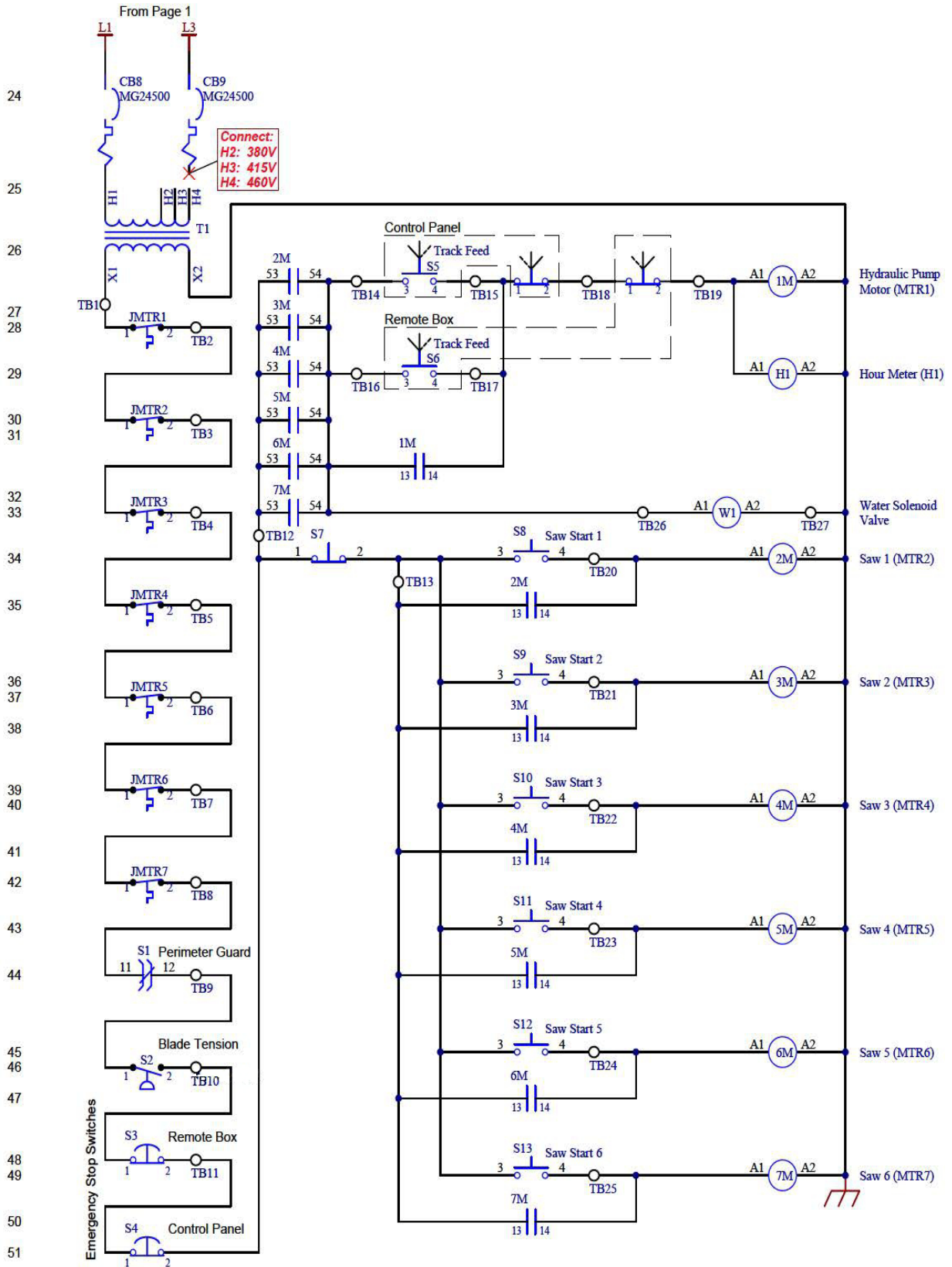

Note: JMTR1 through JMTR7 are thermostats mounted internally in their respective motors.

ELECTRICAL COMPONENT DIAGRAM



① Used for M68 Merry Go Round option only.

② Used for Soft Start option only.

MH0206-3

MAIN CONTROL PANEL DIAGRAM

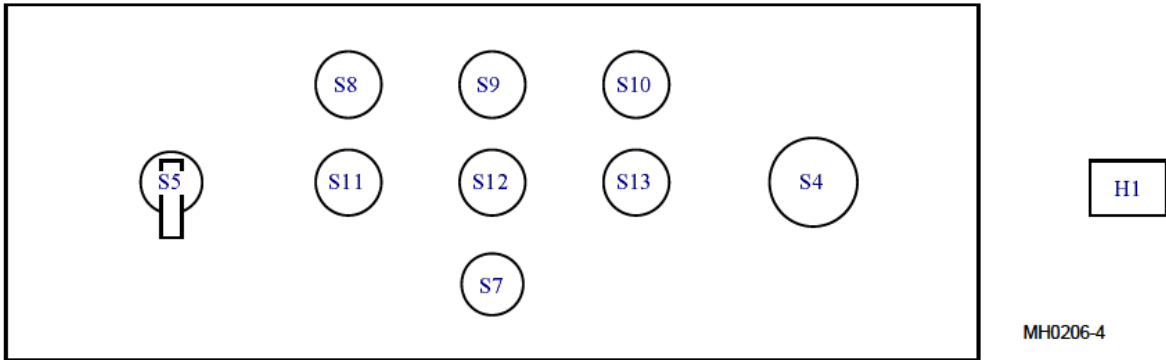

REMOTE CONTROL PANEL DIAGRAM

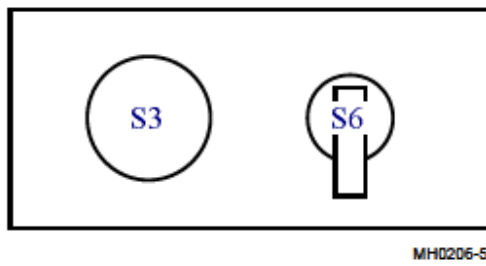

ELECTRICAL COMPONENT LIST		
PART	W-M PART #	DESCRIPTION
1M	E23403	Contactors, 9 Amp 120VAC Coil 50/60HZ IEC
2M - 7M	053600 ¹	Contactors, 40A 3P 120VAC D-A Series
	E23408	Block, Auxiliary Contact
MTR1	065479 ²	Motor, 5HP 3PH 3450RPM Baldor
MTR2 - MTR7	038485	Motor, 25HP 1725RPM
CB1	024691 ³	Circuit Breaker, 6A 480V 3P D-Curve
	050335 ³	Circuit Breaker, 8A 480V 3P D-Curve
CB2 - CB7	024690	Circuit Breaker, 40A 480V 3P D-Curve
CB8, CB9	024585	Circuit Breaker, 1A 1P D-Curve
DIS1	069357	Breaker, 600V 250A J-Frame Molded Case
	069358	Handle Kit, J-Frame Door-Mounted Rotary
	069359	Lug Kit, J-Frame Breaker Power Distribution
	069360	Shield, J-Frame Breaker Long Lug
H1	024586	Hour Meter, 115V 50/60 Hz
S1	E22711	Switch, Perimeter Safety
	E22711-1	Key, Perimeter Safety Switch
S2	E22726 ⁴	Switch, Hydraulic Pressure
S3 & S4 (Two Pieces)	050551	Switch Operator, Red Emergency Stop
		Switch Contact Block, Emergency Stop (Normally Closed)
S5 & S6 (Two Pieces)	050552	Switch Operator, 3-Position Track Feed
		Switch Contact, Track Feed (Normally Open)
S7 (Two Pieces)	050549	Switch Operator, Blade/Track Stop
		Switch Contact Block, Blade/Track Stop (Normally Closed)
S8 - S13 (Two Pieces)	050554	Switch Operator, Saw Head Start
		Switch Contact Block, Saw Head Start (Normally Open)
T1	024696	Transformer, 460-415-380/120 250VA
TB	024893	Terminal Block, 1 Tier
	050935	End Cap, Terminal Block
W1 (2 pieces)	110774 ⁵	Valve Assembly
	P22514	Nut, Solenoid Valve

¹ DIN rail-mount contactor 053600 replaces panel-mount contactor E23293 originally supplied prior to 1/11 due to a change in vendor supply. Replacement of old-style contactor requires DIN rail 024474-3_25, two screws F05015-17 and two clamps E22707. Two 5/32" diameter holes in the mounting panel are required to mount DIN rail.

² 5HP Motor 065479 replaces 4HP Motor P22735 originally supplied prior to Rev. A2.00. 4HP Motor available to service previous revisions while supplies last. When stock depleted, upgrade to 5HP motor with kit 065492 (Includes Motor, Couplings, Pump Adaptor & Hardware).

³ Use 6A Breaker 024691 for 4HP hydraulic motor originally supplied prior to Rev. A2.00. Use 8A Breaker 050335 for Rev. A2.00+ or if retrofitted with 5HP motor.

⁴ Switch E22726 changed by manufacturer 4/11. New switch has straight wire connection. Replace fitting on connecting harness with swivel connector 051750.

⁵ Replaced E22772 Solenoid Valve, 110 VAC 50/60 Hz no longer available (1/19).