



## Parts Manual

---

**LT300, LT300-BX6,  
LT300-BX10**

**rev. A1.00 - B4.01**



**Safety is our #1 concern!** Read and understand all safety information and instructions before operating, setting up or maintaining this machine.

*April 2005*

*Form #991*

**California**

Proposition 65 Warning



**WARNING:** Breathing gas/diesel engine exhaust exposes you to chemicals known to the State of California to cause cancer and birth defects or other reproductive harm.

Always start and operate the engine in a well-ventilated area.  
If in an enclosed area, vent the exhaust to the outside.  
Do not modify or tamper with the exhaust system.  
Do not idle the engine except as necessary.

For more information go to **[www.P65warnings.ca.gov](http://www.P65warnings.ca.gov)**.



**WARNING:** Drilling, sawing, sanding or machining wood products can expose you to wood dust, a substance known to the State of California to cause cancer. Avoid inhaling wood dust or use a dust mask or other safeguards for personal protection.

For more information go to **[www.P65Warnings.ca.gov/wood](http://www.P65Warnings.ca.gov/wood)**.

©2019

Printed in the United States of America, all rights reserved. No part of this manual may be reproduced in any form by any photographic, electronic, mechanical or other means or used in any information storage and retrieval system without written permission from

**Wood-Mizer**  
**8180 West 10th Street**  
**Indianapolis, Indiana 46214**

<b>SECTION 1</b>	<b>GENERAL INFORMATION</b>	<b>1-1</b>
1.1	How To Use The Parts List .....	1-1
1.2	Sample Assembly .....	1-1
<b>SECTION 2</b>	<b>BLADE GUIDES &amp; ARM</b>	<b>2-1</b>
2.1	Blade Guide Kit (Roller/Block, Standard) .....	2-1
2.2	Blade Guide Kit (Block, Optional).....	2-2
2.3	Blade Guide Assembly, Idle Side (Roller/Block, Standard) .....	2-3
	<i>LT300 Rev. B3.01</i>	
2.4	Blade Guide Assembly, Idle Side (Roller/Block, Standard) .....	2-6
	<i>LT300 Rev. A9.04 - B3.00</i>	
2.5	Blade Guide Assembly, Idle Side (Roller/Block, Standard) .....	2-9
	<i>LT300 Rev. A1.00 - A9.03</i>	
2.6	Blade Guide Assembly, Idle Side (Block, Optional) .....	2-12
2.7	Blade Guide Assembly, Drive Side (Roller/Block, Standard) .....	2-14
	<i>LT300 Rev. B3.01</i>	
2.8	Blade Guide Assembly, Drive Side (Roller/Block, Standard) .....	2-17
	<i>LT300 Rev. A9.04 - B3.00</i>	
2.9	Blade Guide Assembly, Drive Side (Roller/Block, Standard) .....	2-20
	<i>LT300 Rev. A1.00 - A9.03</i>	
2.10	Blade Guide Assembly, Drive Side (Block, Optional).....	2-23
2.11	Blade Guide Arm.....	2-25
<b>SECTION 3</b>	<b>BLADE WHEELS &amp; TENSIONER</b>	<b>3-1</b>
3.1	Drive Shaft Assembly.....	3-1
	<i>LT300 Rev. A8.00+</i>	
3.2	Drive Shaft Assembly.....	3-2
	<i>LT300 Rev. A4.00 - A7.02</i>	
3.3	Drive Shaft Assembly.....	3-3
	<i>LT300 Rev. A1.00 - A3.00</i>	
3.4	Idle Shaft/Brake Drum .....	3-4
3.5	Blade Wheel Kit, Belted (Standard).....	3-5
3.6	Blade Wheel Kit, Crowned (Optional).....	3-7
3.7	Brake Assembly.....	3-9
3.8	Blade Motor Drive Assembly.....	3-11
	<i>LT300 Rev. A8.00+</i>	
3.9	Blade Motor Drive Assembly.....	3-13
	<i>LT300 Rev. A7.00 - A7.03</i>	
3.10	Blade Motor Drive Assembly.....	3-15
	<i>LT300 Rev. A1.00 - A6.01</i>	

## Table of Contents

## Section-Page

<b>SECTION 4</b>	<b>SAW HEAD</b>	<b>4-1</b>
4.1	Board Return ..... <i>LT300 Rev. B2.02+</i>	4-1
4.2	Board Return ..... <i>LT300 Rev. A7.00 - B2.01</i>	4-2
4.3	Board Return ..... <i>LT300 Rev. A1.00 - A6.01</i>	4-3
4.4	Board Return Guide..... <i>LT300 Rev. A4.00+</i>	4-4
4.5	Board Return Guide..... <i>LT300 Rev. A1.00 - A3.00</i>	4-5
4.6	Covers & Sawdust Chute..... <i>LT300 Rev. B2.00+</i>	4-6
4.7	Covers & Sawdust Chute..... <i>LT300 Rev. A9.00 - B1.01</i>	4-8
4.8	Covers & Sawdust Chute..... <i>LT300 Rev. A7.00 - A8.00</i>	4-10
4.9	Covers & Sawdust Chute..... <i>LT300 Rev. A1.00 - A6.01</i>	4-12
4.10	Blow-Off Assembly..... <i>LT300 Rev. A2.00+</i>	4-14
4.11	Blow-Off Assembly..... <i>Rev. A1.00 - A1.01</i>	4-15
4.12	Laser Assembly .....	4-16
4.13	Decals .....	4-18
4.14	Decals .....	4-19
4.15	Head/Air Box Control Assembly .....	4-20
<b>SECTION 5</b>	<b>UP/DOWN SYSTEM</b>	<b>5-1</b>
5.1	Mast Pads & Rollers.....	5-1
5.2	Bearing Rails .....	5-3
5.3	Up/Down Ballscrew Drive .....	5-4
	<i>LT300 Rev. B2.00+</i>	
5.4	Up/Down Ballscrew Drive .....	5-6
	<i>LT300 Rev. A4.00 - B1.01</i>	
5.5	Up/Down Ballscrew Drive .....	5-8
	<i>LT300 Rev. A3.00</i>	
5.6	Up/Down Ballscrew Drive .....	5-10
	<i>LT300 Rev. A1.00 - A2.01</i>	
5.7	Ballscrew Mount (Middle) .....	5-12
	<i>LT300 Rev. A3.00+</i>	



## Table of Contents

## Section-Page

5.8	Ballscrew Mount (Middle) .....	5-14
	<i>LT300 Rev. A1.00 - A2.01</i>	
5.9	Ballscrew Mount (Top) .....	5-15
	<i>LT300 Rev. A3.00+</i>	
5.10	Ballscrew Mount (Top) .....	5-16
	<i>LT300 Rev. A1.00 - A2.01</i>	
5.11	Transducer & Head Stop .....	5-17
	<i>LT300 Rev. B4.00+</i>	
5.12	Transducer & Head Stop .....	5-19
	<i>LT300 Rev. B2.00 - B3.02</i>	
5.13	Transducer & Head Stop .....	5-21
	<i>LT300 Rev. A9.02 - B1.01</i>	
5.14	Transducer & Head Stop .....	5-23
	<i>LT300 Rev. A1.00 - A9.01</i>	

## SECTION 6 POWER FEED

## 6-1

6.1	Upper Track Rollers .....	6-1
6.2	Lower Track Rollers.....	6-3
	<i>LT300 Rev. A8.00+</i>	
6.3	Lower Track Rollers.....	6-5
	<i>LT300 Rev. A6.00 - A7.02</i>	
6.4	Lower Track Rollers.....	6-7
	<i>LT300 Rev. A1.00 - A5.01</i>	
6.5	Power Feed Drive.....	6-9
6.6	Track Oiler System.....	6-11
	<i>LT300 Rev. A1.00 - A5.00</i>	
6.7	Feed Chain & Stops.....	6-13
	<i>LT300 Rev. A7.00+</i>	
6.8	Feed Chain & Stops.....	6-14
	<i>LT300 Rev. A5.00 - A6.01</i>	
6.9	Feed Chain & Stops.....	6-16
	<i>LT300 Rev. A1.00 - A4.00</i>	
6.10	Lower Wireway.....	6-18
	<i>LT300 Rev. B4.00+</i>	
6.11	Lower Wireway.....	6-19
	<i>LT300 Rev. B2.00 - B3.02</i>	
6.12	Lower Wireway.....	6-20
	<i>LT300 Rev. A7.00 - B1.01</i>	
6.13	Lower Wireway.....	6-22
	<i>LT300 Rev. A6.00 - A6.01</i>	
6.14	Lower Wireway.....	6-24
	<i>LT300 Rev. A5.00 - A5.01</i>	
6.15	Lower Wireway.....	6-26
	<i>LT300 Rev. A1.00 - A4.00</i>	

# Table of Contents

# Section-Page

<b>SECTION 7</b>	<b>BED FRAME</b>	<b>7-1</b>
7.1	Bed Rail #1 (Front)..... <i>LT300 Rev. A7.00+</i>	7-1
7.2	Bed Rail #1..... <i>LT300 Rev. A1.00 - A6.01</i>	7-2
7.3	Bed Rail #2 (Middle Front).....	7-3
7.4	Bed Rail (Middle)..... <i>LT300 Rev. A7.00+</i>	7-4
7.5	Bed Rail (Middle)..... <i>LT300 Rev. A1.00 - A6.01</i>	7-5
7.6	Bed Rail #4 (Middle Rear).....	7-6
7.7	Bed Rail #5 (Rear)..... <i>LT300 Rev. A7.00+</i>	7-7
7.8	Bed Rail #5..... <i>LT300 Rev. A1.00 - A6.01</i>	7-8
7.9	Leg Assembly (Front & Rear)..... <i>LT300 Rev. B4.00+ (with Pantograph Cable Boom)</i>	7-10
7.10	Leg Assembly (Front & Rear)..... <i>LT300 Rev. A7.00 - B3.02</i> <i>LT300 Rev. B4.00+ (without Pantograph Cable Boom)</i>	7-11
7.11	Leg Assembly (Front & Rear)..... <i>LT300 Rev. A5.00 - A6.01</i>	7-12
7.12	Leg Assembly (Front & Rear)..... <i>LT300 Rev. A1.00 - A4.00</i>	7-13
7.13	Leg Assembly (#1 & #2)..... <i>LT300 Rev. A1.00 - A4.00</i>	7-14
7.14	Leg Assembly (#2 & #5)..... <i>LT300 Rev. B4.00+ (with Pantograph Cable Boom)</i>	7-16
7.15	Leg Assembly (#2 & #5)..... <i>LT300 Rev. A7.00 - B3.02</i> <i>LT300 Rev. B4.00+ (without Pantograph Cable Boom)</i>	7-17
7.16	Leg Assembly (#3 & #4)..... <i>LT300 Rev. B4.00+ (with Pantograph Cable Boom)</i>	7-18
7.17	Leg Assembly (#3 & #4)..... <i>LT300 Rev. A7.00 - B3.02</i> <i>LT300 Rev. B4.00+ (without Pantograph Cable Boom)</i>	7-19
7.18	Leg Assembly (#3 & #4)..... <i>LT300 Rev. A1.00 - A6.01</i>	7-20
7.19	Wireway..... <i>LT300 Rev. A7.00 - B3.02</i> <i>LT300 Rev. B4.00+ (without Pantograph Cable Boom)</i>	7-22
7.20	Wireway (LT300-BX6)..... <i>LT300-BX6 Rev. A7.00 - B3.02</i>	7-23

## Table of Contents

## Section-Page

7.21	Wireway .....	7-25
	<i>LT300 Rev. A5.00 - A6.01</i>	
7.22	Wireway .....	7-27
	<i>LT300 Rev. A1.00 - A4.00</i>	
7.23	Cable Carrier .....	7-29
	<i>LT300 Rev. A7.00 - B3.02</i>	
	<i>LT300 Rev. B4.00+ (without Pantograph Cable Boom)</i>	
7.24	Cable Carrier .....	7-30
	<i>LT300 Rev. A5.00 - A6.01</i>	
7.25	Cable Carrier .....	7-31
	<i>LT300 Rev. A1.00 - A4.00</i>	
<b>SECTION 8      HYDRAULICS</b>		<b>8-1</b>
8.1	Hydraulic Log Loader Option .....	8-1
	<i>LT300 Rev. B1.00+</i>	
8.2	Hydraulic Log Loader Option .....	8-3
	<i>LT300 Rev. A3.00 - A9.06</i>	
8.3	Hydraulic Log Loader .....	8-5
	<i>LT300 Rev. A1.00 - A2.01</i>	
8.4	Hydraulic Side Supports.....	8-6
8.5	Side Support (Optional Middle).....	8-8
8.6	Hydraulic Log Turner.....	8-10
	<i>LT300 Rev. B4.00+</i>	
8.7	Hydraulic Log Turner.....	8-12
	<i>Rev. A2.00 - B3.02</i>	
8.8	Hydraulic Log Turner.....	8-14
	<i>Rev. A1.00 - A1.01</i>	
8.9	Hydraulic Log Clamp .....	8-16
8.10	Hydraulic Toe Board (Front).....	8-18
8.11	Hydraulic Toe Board (Rear).....	8-19
8.12	Hydraulic Toe Board (Rear w/Ramp) .....	8-20
8.13	Hydraulic Pump & Tank .....	8-21
	<i>LT300 Rev. B2.00+</i>	
8.14	Hydraulic Pump & Tank .....	8-23
	<i>LT300 Rev. A5.00 - B1.01</i>	
8.15	Hydraulic Pump, Tank & Valve.....	8-25
	<i>LT300 Rev. A1.00 - A4.00</i>	
8.16	Hydraulic Valve.....	8-28
	<i>LT300 Retrofit</i>	
8.17	Hydraulic Valve.....	8-30
	<i>LT300 Rev. A9.00 - B4.01</i>	
8.18	Hydraulic Valve.....	8-32
	<i>LT300 Rev. A7.00 - A8.00</i>	

## Table of Contents

## Section-Page

8.19	Hydraulic Valve.....	8-34
	<i>LT300 Rev. A1.00 - A6.01</i>	
8.20	Power Taper Set Roller (Optional).....	8-37
	<i>LT300/WM3000/WM3500</i>	
8.21	Valve Assembly, Power Taper Set Roller (Optional).....	8-39
8.22	Hydraulic Hoses .....	8-40
	<i>LT300 Rev. A7.00+</i>	
8.23	Hydraulic Hoses .....	8-42
	<i>LT300 Rev. A5.00 - A6.01</i>	
8.24	Hydraulic Hoses .....	8-43
	<i>LT300 Rev. A1.00 - A4.00</i>	
<b>SECTION 9 MISCELLENEOUS</b>		<b>9-1</b>
9.1	Lube System .....	9-1
	<i>LT300 Rev. A9.05+</i>	
9.2	Lube System .....	9-3
	<i>LT300 Rev. A1.00 - A9.04</i>	
9.3	Tools.....	9-5
9.4	Manuals .....	9-6
9.5	Electrical Harnesses/Cables.....	9-7
	<i>LT300 Rev. B4.00+</i>	
9.6	Electrical Harnesses/Cables.....	9-9
	<i>LT300 Rev. B3.00 - B3.02</i>	
9.7	Electrical Harnesses/Cables.....	9-10
	<i>LT300 Rev. A1.00 - B2.02</i>	
9.8	Pantograph Assembly.....	9-11
9.9	Vacuum System (Optional).....	9-13
	<i>LT300 Rev. A1.00 - A4.00</i>	
9.10	Vacuum System Cable Carrier (Optional) .....	9-15
	<i>LT300 Rev. A1.00 - A4.00</i>	
<b>SECTION 10 OPERATOR STATION</b>		<b>10-1</b>
10.1	Frame, Rails & Ladder .....	10-1
	<i>LT300 Rev. B2.00+</i>	
10.2	Frame, Rails & Ladder .....	10-3
	<i>LT300 Rev. A7.00 - B1.01</i>	
10.3	Frame, Rails & Ladder .....	10-5
	<i>LT300 Rev. A1.00 - A6.01</i>	
10.4	Seat & Joystick Controls .....	10-7
	<i>LT300 Rev. B2.00+</i>	
10.5	Seat & Joystick Controls .....	10-9
	<i>LT300 Rev. A1.00 - B1.01</i>	
10.6	Air Supply .....	10-11
	<i>LT300 Rev. A2.00+</i>	

## Table of Contents

## Section-Page

10.7	Air Supply .....	10-13	
	<i>LT300 Rev. A1.00 - A1.01</i>		
<b>SECTION 11</b>	<b>PRESSURE LUBE OPTION</b>		<b>11-1</b>
11.1	Pressure Lube System.....	11-1	
	<i>LT300/WM3000/WM3500 Rev. A1.00+</i>		
<b>SECTION 12</b>	<b>CAB OPTION</b>		<b>12-1</b>
12.1	Cab.....	12-1	
	<i>CAB2 Rev. A1.00+</i>		
12.2	Cab.....	12-2	
	<i>CAB1 Rev. A1.00</i>		
12.3	Frame.....	12-3	
	<i>CAB1 Rev. A1.00</i>		
12.4	Rear Panel.....	12-5	
	<i>CAB2 Rev. A1.00+</i>		
12.5	Rear Panel.....	12-7	
	<i>CAB1 Rev. A1.00</i>		
12.6	Right Panel .....	12-9	
	<i>CAB2 Rev. A1.00</i>		
12.7	Right Panel .....	12-11	
	<i>CAB1 Rev. A1.00</i>		
12.8	Front Panel.....	12-13	
	<i>CAB2 Rev. A1.00</i>		
12.9	Front Panel.....	12-14	
	<i>CAB1 Rev. A1.00</i>		
12.10	Left Panel.....	12-15	
	<i>CAB2 Rev. A1.00</i>		
12.11	Left Panel.....	12-16	
	<i>CAB1 Rev. A1.00</i>		
12.12	Roof.....	12-17	
<b>SECTION 13</b>	<b>BED EXTENSION OPTION</b>		<b>13-1</b>
13.1	Bed Extension Complete (BX6).....	13-1	
	<i>LT300-BX6Rev. B3.02+</i>		
13.2	Bed Extension Complete (BX10).....	13-2	
	<i>LT300-BX10Rev. B4.00+</i>		
13.3	Bed Rails (BX6) .....	13-4	
13.4	Bed Rails (BX10) .....	13-5	
13.5	Side Support (BX6) .....	13-6	
13.6	Manual Clamp (BX6) .....	13-7	
13.7	Manual Clamp (BX10) .....	13-8	
13.8	Legs (BX6) .....	13-9	
13.9	Connection Hardware (BX6).....	13-10	

**Table of Contents**

**Section-Page**

13.10 Connection Hardware (BX10).....13-11  
13.11 Hydraulic Flow Control Valve (BX10).....13-12

**INDEX**

**I**

## SECTION 1 GENERAL INFORMATION

### 1.1 How To Use The Parts List

- Use the table of contents or index to locate the assembly that contains the part you need.
- Go to the appropriate section and locate the part in the illustration.
- Use the number pointing to the part to locate the correct part number and description in the table.
- Parts shown indented under another part are included with that part.
- Parts marked with a diamond (◆) are only available in the assembly listed above the part.

See the sample table below. Sample Part #A01111 includes part F02222-2 and subassembly A03333. Subassembly A03333 includes part S04444-4 and subassembly K05555. The diamond (◆) indicates that S04444-4 is not available except in subassembly A03333. Subassembly K05555 includes parts M06666 and F07777-77. The diamond (◆) indicates M06666 is not available except in subassembly K05555.

1.2 Sample Assembly				
REF	DESCRIPTION (◆ Indicates Parts Available In Assemblies Only)	PART #	QTY.	
	<b>SAMPLE ASSEMBLY, COMPLETE (INCLUDES ALL INDENTED PARTS BELOW)</b>	A01111	1	
1	Sample Part	F02222-22	1	
	Sample Subassembly (Includes All Indented Parts Below)	A03333	1	
2	Sample Part (◆ Indicates Part Is Only Available With A03333)	S04444-4	1	◆
	Sample Subassembly (Includes All Indented Parts Below)	K05555	1	
3	Sample Part (◆ Indicates Part Is Only Available With K05555)	M06666	2	◆
4	Sample Part	F07777-77	1	

#### To Order Parts:

- From the continental U.S., call **1-800-525-8100** to order parts. Have your customer number, vehicle identification number, and part numbers ready when you call.
- From other international locations, contact the Wood-Mizer distributor in your area for parts.

**2** **Blade Guides & Arm**  
*Blade Guide Kit (Roller/Block, Standard)*

**SECTION 2 BLADE GUIDES & ARM**

**2.1 Blade Guide Kit (Roller/Block, Standard)**

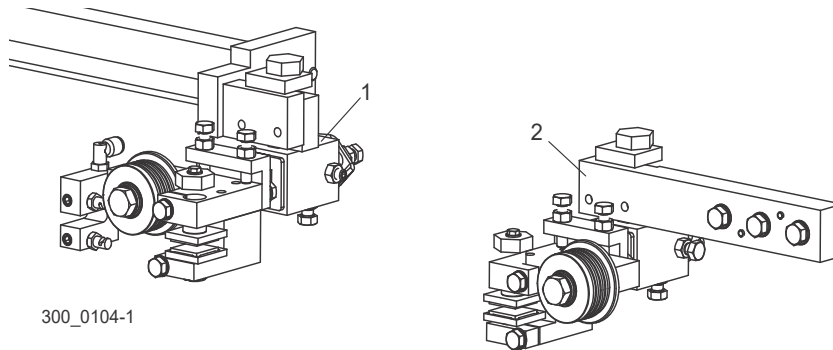

REF	DESCRIPTION (◆ Indicates Parts Available In Assemblies Only)	PART #	QTY.
	<b>GUIDE KIT, BLOCK/ROLLER BLADE <sup>1</sup></b>		
1	Idle Side Blade Guide Parts ( <a href="#">See Section 2.4</a> )		
2	Drive Side Blade Guide Parts ( <a href="#">See Section 2.8</a> )		

<sup>1</sup> Beginning with Rev. A8.00 (11/04), the LT300 was provided with block/roller blade guides as standard equipment. These guides are intended for use with the belted blade wheels supplied as standard equipment on LT300s ([See Section 3.5](#)). To convert to crowned steel wheels and all-block blade guides, use two 017814 crowned wheel assemblies and one 036706 block blade guide kit. Blade Guide Kit 036705 now includes 1 1/2" guide rollers (Rev. B4.01).



## 2.2 Blade Guide Kit (Block, Optional)

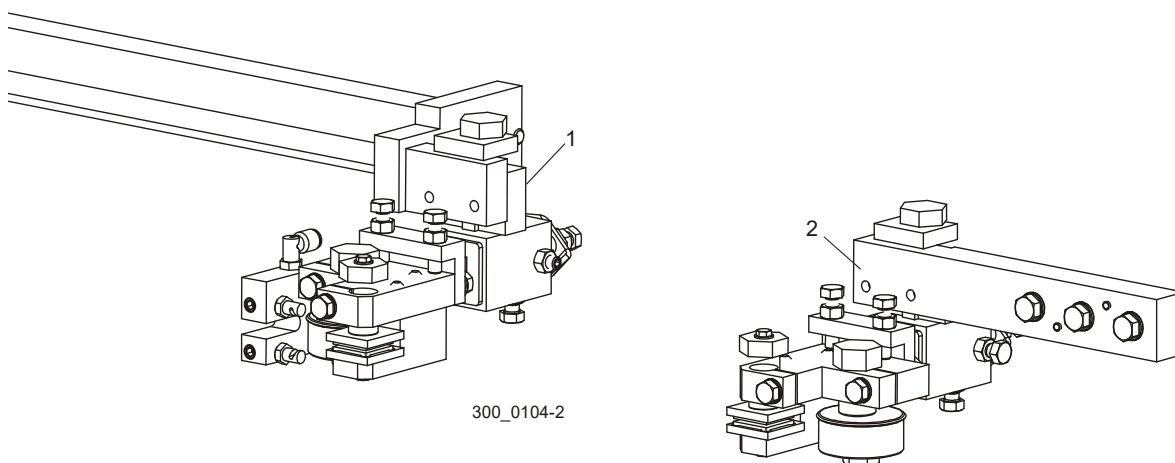

REF	DESCRIPTION (◆ Indicates Parts Available In Assemblies Only)	PART #	QTY.
	<b>GUIDE KIT, BLOCK BLADE <sup>1</sup></b>		
1	Idle Side Blade Guide Parts ( <a href="#">See Section 2.6</a> )		
2	Drive Side Blade Guide Parts ( <a href="#">See Section 2.10</a> )		

<sup>1</sup> Beginning with Rev. A8.00 (11/04), the LT300 was provided with block/roller blade guides as standard equipment. The all-block guides are intended for use with the optional crowned blade wheels ([See Section 3.6](#)). To convert to belted blade wheels and roller/block blade guides, use two 036632 belted wheel assemblies, one 036705 roller/block blade guide kit and one 036841 vibration dampening retrofit (rev. A1.00 - A8.00) or one 036840 vibration dampening kit (Rev. A9.00+).



## Blade Guides & Arm

Blade Guide Assembly, Idle Side (Roller/Block, Standard)

### 2.3 Blade Guide Assembly, Idle Side (Roller/Block, Standard)

LT300

Rev. B3.01

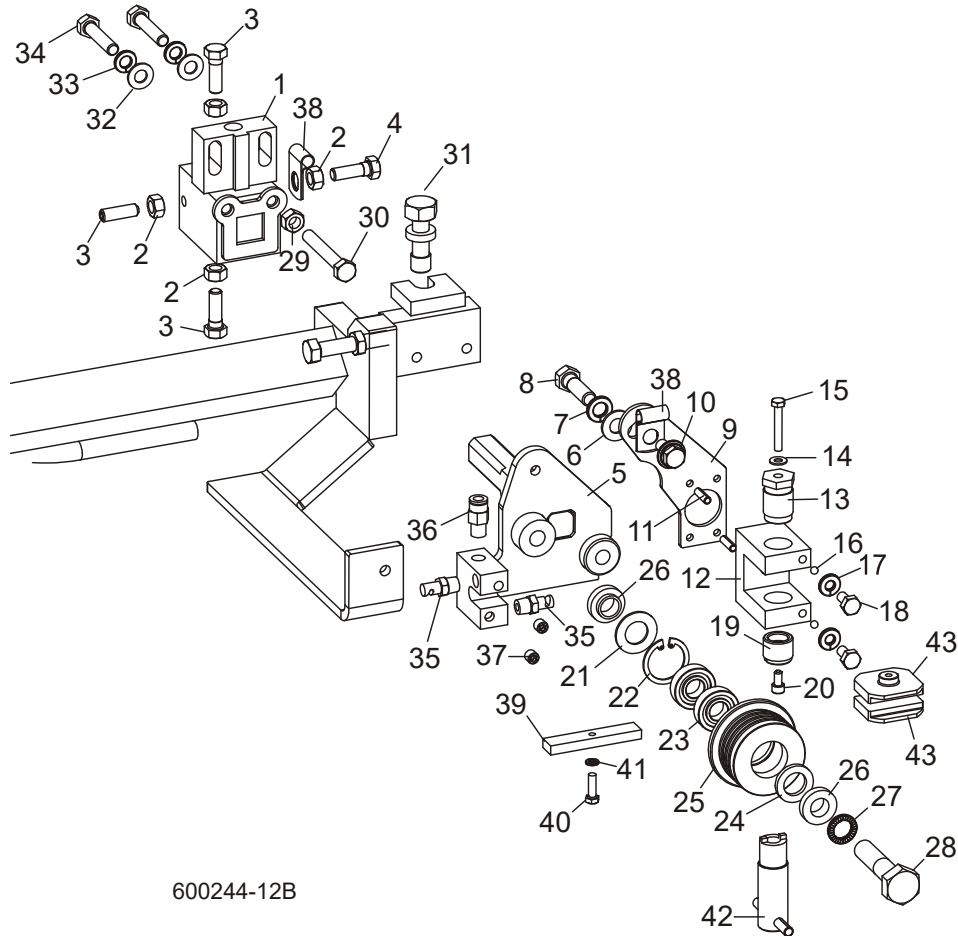

600244-12B

REF	DESCRIPTION (◆ Indicates Parts Available In Assemblies Only)	PART #	QTY.
	<b>ROLLER/BLOCK ASSEMBLY, IDLE SIDE (OUTER)</b>	003926 <sup>1</sup>	1
	Block Assembly, Blade Guide Mount	003910	1
1	Block Weldment, Blade Guide Mount	003911	1 ◆
2	Nut, 5/16-18 Hex	F05010-17	4
3	Bolt, 5/16-18 x 1" Hex Head Stainless Steel	F05006-88	3
4	Screw, 5/16-18 x 1" Socket Head Flat Point Stainless Steel Set	F05006-122	1
5	Shaft Weldment, Idle Side Guide	003924 <sup>2</sup>	1
	Mount Assembly, Blade Guide Block Idle	003928	1
6	Washer, 3/8" SAE Flat	F05011-3	1
7	Washer, 3/8" Split Lock	F05011-4	1
8	Bolt, 3/8-16 x 1 1/4" Hex Head Grade 5	F05007-123	1
9	Plate, Block Tilt Adjustment	003915	1

10	Bolt, 5/16-18 x 3/4" Hex Head w/Flat & Lock Washer	F05006-101	1	
11	Pin, 3/16" x 5/8" Roll	F05012-22	2	
12	Block, Guide Block Mount	003909	1	
13	Bolt, Blade Guide Block Mount	003994	1	
14	Washer, #10 Brass	042867	1	
15	Bolt, #10-32 x 1 1/4" Hex Head Stainless Steel	F05004-240	1	
16	Ball, 3/16" Dia. Nylon	003914	2	
17	Washer, 1/4" Split Lock	F05011-14	2	
18	Bolt, 1/4-20 x 1/2" Hex Head	F05005-15	2	
19	Screw, Lower Block Adjustment	044057	1	
20	Screw, #10-32 x 3/8" Socket Head Stainless Steel	F05004-200	1	
	Roller Assembly, Blade Guide (standard for use with 1 1/4" & 1 1/2" blades)	A04925 <sup>3</sup>	1	
	Roller Assembly, Extended Blade Guide (optional for use with 1 1/2" blades)	014299 <sup>3</sup>	1	
	Roller Assembly, Extended Blade Guide (optional for use with 1 3/4" blades)	057441 <sup>3</sup>	1	
	Bearing Kit, Blade Guide Rebuild	K07079 <sup>3</sup>	1	
21	Washer, 5/8" White Felt	P04252	1	
22	Ring, 1 1/8" Interior Retaining	F04254-1	1	
23	Bearing, R8-2RS Blade Guide	015975	2	◆
24	Washer, 5/8" Gray Felt	P06455	1	
	Screw, 1/4-28 x 1/4" Socket Head Cup Point Set Black Oxide	F05005-105	1	
	Instruction Sheet, Blade Guide Rebuild	057407-1507	1	
25	Roller, Flanged Blade Guide (1 1/4" & 1 1/2" blade)	S04250	1	◆
	Roller, Flanged Blade Guide (1 1/2" blade)	014243	1	◆
	Roller, Flanged Blade Guide (1 3/4" blade)	037598	1	◆
	Instruction Sheet, Blade Guide Roller Replacement	A04925-364	1	
26	Spacer, Blade Guide	S04253	2	
27	Washer, 1/2" Nord-Lock	F05011-125 <sup>4</sup>	1	
28	Bolt, 1/2-13 x 2 1/4" Hex Head Grade 5	F05008-10	1	
29	Nut, 5/16-18 Hex	F05010-17	1	
30	Bolt, 5/16-18 x 2 1/4" Hex Head Full Thread	F05006-16	1	
31	Bolt, Blade Guide Vertical Adjustment	035656	1	
32	Washer, 5/16" SAE Flat	F05011-17	2	
33	Washer, 5/16" Split Lock	F05011-13	2	
34	Bolt, 5/16-18 x 1 1/2" Hex Head Grade 5 Full Thread	F05006-76	2	
35	Fitting, Blade Lube Spray Nozzle	033479	2	
36	Fitting, 1/16" NPT Socket Pipe Plug	007734 <sup>2</sup>	2	
37	Fitting, 1/8" NPT x 1/4" Tube	P03078 <sup>5</sup>	1	
38	Clamp, 1/4" Wire 13/32" Mounting Hole	024155 <sup>5</sup>	2	
39	<b>BLOCK, BLADE GUIDE ALIGNMENT</b>	035799	1	
40	<b>SCREW, #10-32 X 5/8" HEX HEAD</b>	F05004-152	1	
41	<b>WASHER, #10 SPLIT LOCK</b>	F05011-20	1	
42	<b>TOOL, LOWER BLOCK ADJUSTMENT</b>	044064	1	

# 2

## Blade Guides & Arm

### *Blade Guide Assembly, Idle Side (Roller/Block, Standard)*

43	<b>BLOCK, BLADE GUIDE WEAR (STANDARD FOR 1 1/2" OR 1 3/4" BLADES)</b>	052309 <sup>6</sup>	2	
	<b>BLOCK, BLADE GUIDE WEAR (OPTIONAL FOR 1 1/4" BLADES)</b>	052355 <sup>6</sup>	2	
	<b>BLOCK ASSEMBLY, 1" SQ. EZ-GLIDE WEAR</b>	036347 <sup>6</sup>	2	
	<b>SHIM, .008" BLADE GUIDE BLOCK SPACER</b>	035248	1	

<sup>1</sup> Roller/Block Assembly 003926 no longer available. Use component parts to service or order Roller/Block Assembly 036818 for 1-1/4" blades or 065934 for 1-1/2 blades.

<sup>2</sup> Shaft Weldment 003924 modified to provide more clearance for adjustment bolts and to prevent water leaks (Rev. B4.01). New shaft requires two 1/16" NPT Pipe Plugs 007734.

<sup>3</sup> The sawmill is equipped standard with blade guide rollers that can be used with the standard 1 1/2" blade. The roller can also be used with 1 1/4" blades. Optional extended blade guide rollers are available for use with 1 1/2" blades or 1 3/4". The extended rollers may provide more stability during difficult sawing, but will reduce the total amount of times the blade can be reused after sharpening. Order one additional Blade Guide Bearing 015975 in addition to K07079 Rebuild Kit to service 1 3/4" roller.

<sup>4</sup> Nord-Lock Washer F05011-125 replaced Split Lock Washer F05011-9 to prevent loosening due to vibration (Rev. B4.01).

<sup>5</sup> Straight Tube Fitting P03078 replaced Swivel Hose Fitting P09736 and Clamps 024155 add to improve lube hose routing (Rev. B4.01).

<sup>6</sup> 052309 blocks for use with 1 1/2" blade provided as standard equipment or optional 1 3/4" blade. 052355 blocks available for optional use with 1 1/4" blades. EZ-Glide blocks 036347 are available for customers who prefer this block

## 2.4 Blade Guide Assembly, Idle Side (Roller/Block, Standard)

LT300

Rev. A9.04 - B3.00

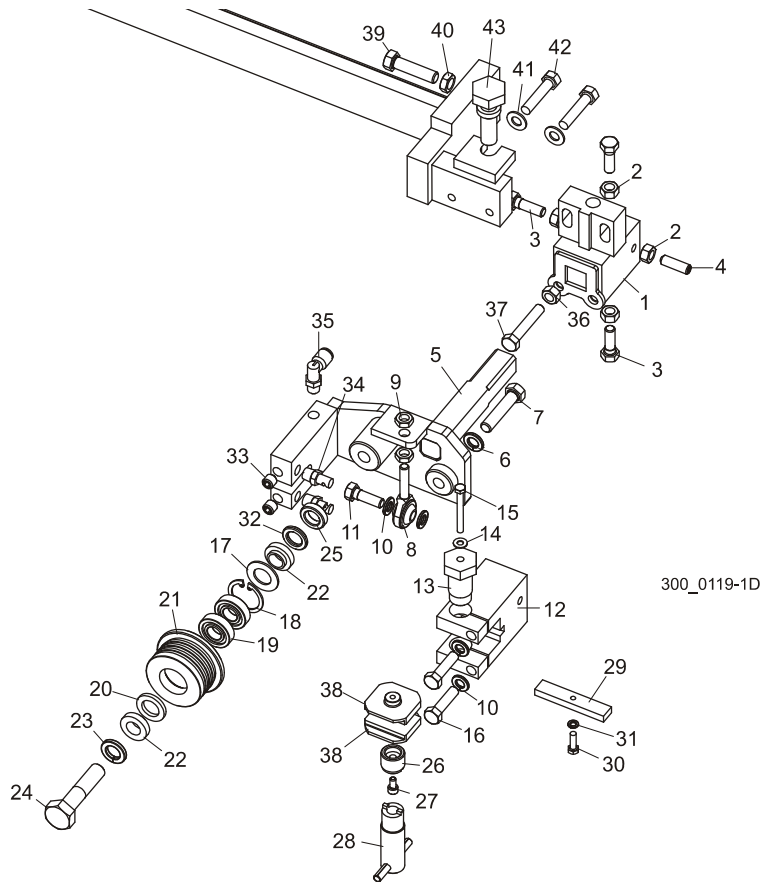

REF	DESCRIPTION (◆ Indicates Parts Available In Assemblies Only)	PART #	QTY.	
	<b>ROLLER/BLOCK ASSEMBLY, IDLE SIDE (OUTER)</b>	036818	1	◆
	Block Assembly, Blade Guide Mount	036872	1	
1	Block Weldment, Blade Guide Mount	036868	1	◆
2	Nut, 5/16-18 Hex	F05010-17	4	
3	Bolt, 5/16-18 x 1" Hex Head Stainless Steel	F05006-88	3	
4	Screw, 5/16-18 x 1" Socket Head Flat Point Stainless Steel Set	F05006-122	1	
5	Shaft Weldment, Idle Side Guide	036866	1	
6	Washer, 3/8" Split Lock	F05011-4	1	
7	Bolt, 3/8-16 x 1 3/4" Full Thread Hex Head Grade 5	F05007-129	1	
8	Rod End, 5/16-24 Male	P09814	1	
9	Nut, 5/16-24 Hex Jam	F05010-28	2	
10	Washer, 5/16" Split Lock	F05011-13	4	
11	Bolt, 5/16-18 x 1" Hex Head Stainless Steel	F05006-88	1	
12	Block, Guide Block Mount	036814	1	
13	Bolt, Blade Guide Block Mount	035216	1	

# 2

## Blade Guides & Arm

### Blade Guide Assembly, Idle Side (Roller/Block, Standard)

14	Washer, #10 Brass	042867	1	
15	Bolt, #10-32 x 1 3/4" Hex Head Stainless Steel	F05004-178	1	
16	Bolt, 5/16-18 x 1 1/4" Hex Head Stainless Steel	F05006-118	2	
	Roller Assembly, Blade Guide (standard for use with 1 1/4" & 1 1/2" blades)	A04925 <sup>1</sup>	1	
	Roller Assembly, Extended Blade Guide (optional for use with 1 1/2" blades)	014299 <sup>1</sup>	1	
	Roller Assembly, Extended Blade Guide (optional for use with 1 3/4" blades)	057441 <sup>1</sup>	1	
	Bearing Kit, Blade Guide Rebuild	K07079 <sup>1</sup>	1	
17	Washer, 5/8" White Felt	P04252	1	
18	Ring, 1 1/8" Interior Retaining	F04254-1	1	
19	Bearing, R8-2RS Blade Guide	015975	2	◆
20	Washer, 5/8" Gray Felt	P06455	1	
	Screw, 1/4-28 x 1/4" Socket Head Cup Point Set Black Oxide	F05005-105	1	
	Instruction Sheet, Blade Guide Rebuild	057407-1507	1	
21	Roller, Flanged Blade Guide (1 1/4" & 1 1/2" blade)	S04250	1	◆
	Roller, Flanged Blade Guide (1 1/2" blade)	014243	1	◆
	Roller, Flanged Blade Guide (1 3/4" blade)	037598	1	◆
	Instruction Sheet, Blade Guide Roller Replacement	A04925-364	1	
22	Spacer, Blade Guide	S04253	2	
23	Washer, 1/2" Split Lock	F05011-9 <sup>2</sup>	1	
24	Bolt, 1/2-13 x 2 1/4" Hex Head Grade 5	F05008-10	1	
25	Spacer, 1/2" ID x 7/8" OD x 1/4" (for 1 1/4" blades only)	041626 <sup>3</sup>	1	
26	Screw, Lower Block Adjustment	044057	1	
27	Screw, #10-32 x 3/8" Socket Head Stainless Steel	F05004-200	1	
28	Tool, Lower Block Adjustment	044064	1	
29	Block, Blade Guide Alignment	035799	1	
30	Screw, #10-32 x 5/8" Hex Head	F05004-152	1	
31	Washer, #10 Split Lock	F05011-20	1	
32	Spacer, 1/2" ID x 7/8" OD x 1/8" Thick (for 1 1/2" blades only)	052364 <sup>3</sup>	1	
33	Fitting, 1/8" NPT Socket Pipe Plug	P30127	2	
34	Fitting, Blade Lube Spray Nozzle	033479	2	
35	Fitting, 1/8" MPT x 1/4" Tube Swivel Elbow	P09736	1	
36	Nut, 5/16-18 Hex	F05010-17	1	
37	Bolt, 5/16-18 x 1 3/4" Hex Head Full Thread	F05006-17	1	
38	<b>BLOCK, BLADE GUIDE WEAR (STANDARD FOR 1 1/2" OR 1 3/4" BLADES)</b>	052309 <sup>4</sup>	2	
	<b>BLOCK, BLADE GUIDE WEAR (OPTIONAL FOR 1 1/4" BLADES)</b>	052355 <sup>4</sup>	2	
	<b>BLOCK ASSEMBLY, 1" SQ. EZ-GLIDE WEAR</b>	036347 <sup>4</sup>	2	
39	<b>BOLT, 3/8-16 X 1 1/2" HEX HEAD FULL THREAD</b>	F05007-17	1	
40	<b>NUT, 3/8-16 HEX JAM</b>	F05010-29	1	
41	<b>WASHER, 5/16" SAE FLAT</b>	F05011-17	2	
42	<b>BOLT, 5/16-18 X 1 1/2" HEX HEAD</b>	F05008-96	2	
43	<b>BOLT, BLADE GUIDE VERTICAL ADJUSTMENT</b>	035656	1	

<b>SHIM, .008" CERAMIC INSERT SPACER</b>	035248	1	
--	--------	---	--

- <sup>1</sup> The sawmill is equipped standard with blade guide rollers that can be used with the standard 1 1/2" blade. The roller can also be used with 1 1/4" blades. Optional extended blade guide rollers are available for use with 1 1/2" blades or 1 3/4". The extended rollers may provide more stability during difficult sawing, but will reduce the total amount of times the blade can be reused after sharpening. Order one additional Blade Guide Bearing 015975 in addition to K07079 Rebuild Kit to service 1 3/4" roller.
- <sup>2</sup> Nord-Lock Washer F05011-125 available to replace Split Lock Washer F05011-9 to prevent loosening due to vibration (12/09).
- <sup>3</sup> Use 1/8" spacer 052364 with 1 1/2" blade provided as standard equipment. Use 1/4" spacer 041626 for optional 1 1/4" blades.
- <sup>4</sup> 052309 blocks for use with 1 1/2" blade provided as standard equipment or optional 1 3/4" blade. 052355 blocks available for optional use with 1 1/4" blades. EZ-Glide blocks 036347 are available for customers who prefer this block (requires spacer 052364 for use with 1 1/4" blades). Blocks removed from blade guide assembly BOM to allow structuring of blade guide assembly in various equipment (11/05).



## Blade Guides & Arm

Blade Guide Assembly, Idle Side (Roller/Block, Standard)

### 2.5 Blade Guide Assembly, Idle Side (Roller/Block, Standard)

LT300

Rev. A1.00 - A9.03

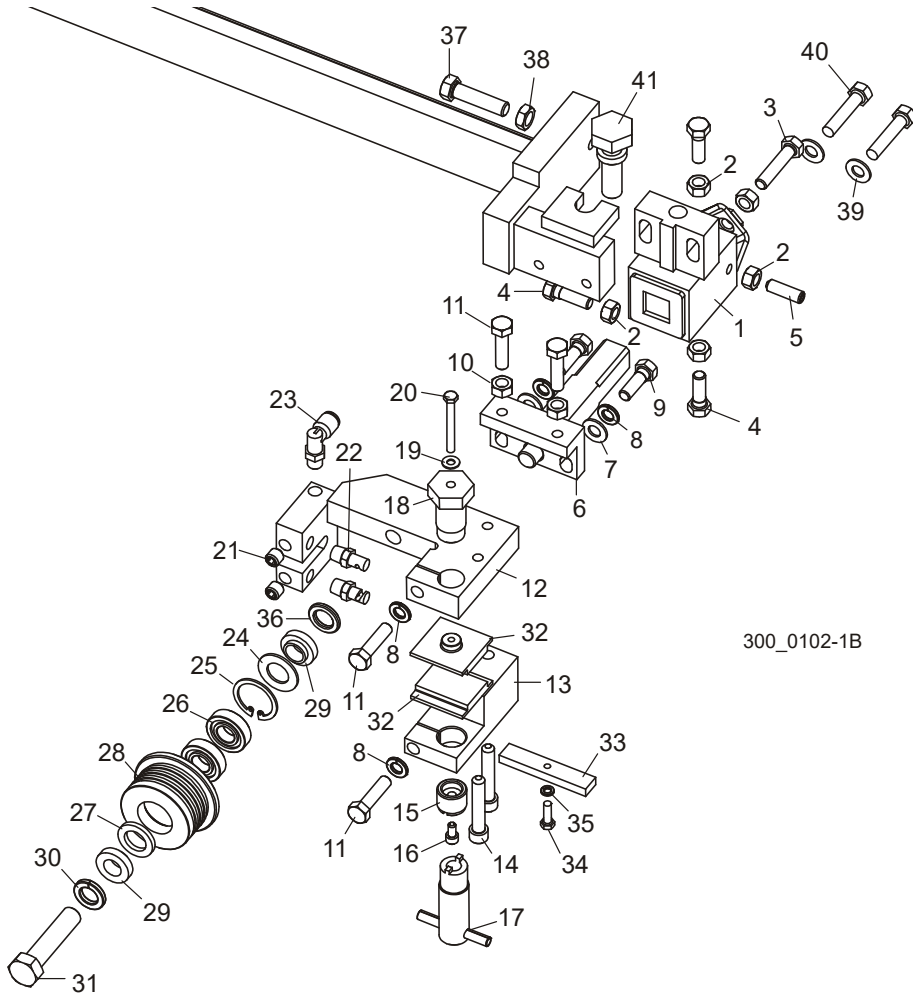

REF	DESCRIPTION (◆ Indicates Parts Available In Assemblies Only)	PART #	QTY.	
	<b>GUIDE ASSEMBLY, IDLE SIDE BLOCK/ROLLER</b>	044055 <sup>1</sup>	1	◆
	Block Assembly, Idle Side Blade Guide	036099	1	
1	Block Weldment, Blade Guide Mount	035219	1	◆
2	Nut, 5/16-18 Hex	F05010-17	5	
3	Bolt, 5/16-18 x 1 1/2" Hex Head Full Thread Stainless Steel	F05006-119	1	
4	Bolt, 5/16-18 x 1" Hex Head Stainless Steel	F05006-88	3	
5	Screw, 5/16-18 x 1" Socket Head Flat Point Stainless Steel	F05006-122	1	
6	Shaft Weldment, Block Guide Pivot	035209	1	
7	Washer, 5/16" SAE Flat	F05011-17	2	
8	Washer, 5/16" Split Lock	F05011-13	4	
9	Bolt, 5/16-18 x 1" Hex Head Stainless Steel	F05006-88	2	
10	Nut, 5/16-18 Hex	F05010-17	2	



11	Bolt, 5/16-18 x 1 1/4" Hex Head Stainless Steel	F05006-118	4	
12	Block Weldment, Upper Blade Guide	044054	1	
13	Block, Lower Blade Guide	044053	1	
14	Screw, 5/16-18 x 1 3/4" Socket Head	F05006-65	2	
15	Screw, Lower Block Adjustment	044057	1	
16	Screw, #10-32 x 3/8" Socket Head Stainless Steel	F05004-200	1	
17	Tool, Lower Block Adjustment	044064	1	
18	Bolt, Blade Guide Block Mount	035216	1	
19	Washer, #10 Brass	042867	1	
20	Bolt, #10-32 x 1 3/4" Hex Head Stainless Steel	F05004-178	1	
21	Fitting, 1/8" NPT Socket Pipe Plug	P30127	2	
22	Fitting, Blade Lube Spray Nozzle	033479	2	
23	Fitting, 1/8" MPT x 1/4" Tube Swivel Elbow	P09736	1	
	Roller Assembly, Blade Guide (standard for use with 1 1/4" & 1 1/2" blades)	A04925 <sup>2</sup>	1	
	Roller Assembly, Extended Blade Guide (optional for use with 1 1/2" blades)	014299 <sup>2</sup>	1	
	Roller Assembly, Extended Blade Guide (optional for use with 1 3/4" blades)	057441 <sup>2</sup>	1	
	Bearing Kit, Blade Guide Rebuild	K07079 <sup>2</sup>	1	
24	Washer, 5/8" White Felt	P04252	1	
25	Ring, 1 1/8" Interior Retaining	F04254-1	1	
26	Bearing, R8-2RS Blade Guide	015975	2	◆
27	Washer, 5/8" Gray Felt	P06455	1	
	Screw, 1/4-28 x 1/4" Socket Head Cup Point Set Black Oxide	F05005-105	1	
	Instruction Sheet, Blade Guide Rebuild	057407-1507	1	
28	Roller, Flanged Blade Guide (1 1/4" & 1 1/2" blade)	S04250	1	◆
	Roller, Flanged Blade Guide (1 1/2" blade)	014243	1	◆
	Roller, Flanged Blade Guide (1 3/4" blade)	037598	1	◆
	Instruction Sheet, Blade Guide Roller Replacement	A04925-364	1	
29	Spacer, Blade Guide	S04253	2	
30	Washer, 1/2" Split Lock	F05011-9 <sup>3</sup>	1	
31	Bolt, Blade Guide Roller Mount	036399	1	
32	Block, Blade Guide Wear (Standard for 1 1/2" or 1 3/4" Blades)	052309 <sup>4</sup>	2	
	Block, Blade Guide Wear (Optional for 1 1/4" Blades)	052355 <sup>4</sup>	2	
	Block Assembly, 1" Sq. EZ-Glide Wear	036347 <sup>4</sup>	2	
33	Block, Blade Guide Alignment	035799	1	
34	Screw, #10-32 x 5/8" Hex Head	F05004-152	1	
35	Washer, #10 Split Lock	F05011-20	1	
36	Spacer, 1/2" ID x 7/8" OD x 1/8" Thick (for 1 1/4" blades only)	052364 <sup>5</sup>	1	
37	<b>BOLT, 3/8-16 X 1 1/2" HEX HEAD FULL THREAD</b>	F05007-17	1	
38	<b>NUT, 3/8-16 HEX JAM</b>	F05010-29	1	
39	<b>WASHER, 5/16" SAE FLAT</b>	F05011-17	2	
40	<b>BOLT, 5/16-18 X 1 1/2" HEX HEAD</b>	F05008-96	2	
41	<b>BOLT, BLADE GUIDE VERTICAL ADJUSTMENT</b>	035656	1	

# 2

## Blade Guides & Arm

### Blade Guide Assembly, Idle Side (Roller/Block, Standard)

	<b>SHIM, .008" CERAMIC INSERT SPACER</b>	035248	1	
--	--	--------	---	--

- <sup>1</sup> 044055 Blade Guide Assembly replaced with 036818 Rev. A9.04 and no longer available. Use component parts to service or replace entire assembly with 036818. New assembly provides easier adjustment ([See Section 2.4](#)).
- <sup>2</sup> The sawmill is equipped standard with blade guide rollers that can be used with the standard 1 1/2" blade. The roller can also be used with 1 1/4" blades. Optional extended blade guide rollers are available for use with 1 1/2" blades or 1 3/4". The extended rollers may provide more stability during difficult sawing, but will reduce the total amount of times the blade can be reused after sharpening. Order one additional Blade Guide Bearing 015975 in addition to K07079 Rebuild Kit to service 1 3/4" roller.
- <sup>3</sup> Nord-Lock Washer F05011-125 available to replace Split Lock Washer F05011-9 to prevent loosening due to vibration (12/09).
- <sup>4</sup> Blade guide wear blocks 052309 & 052355 replace EZ-Glide block 036347 to improve wear life (Rev. A9.00). 052309 blocks for use with 1 1/2" blade provided as standard equipment or optional 1 3/4" blade. 052355 blocks available for optional use with 1 1/4" blades. EZ-Glide blocks 036347 are available for customers who prefer this block (requires spacer 052364 for use with 1 1/4" blades).
- <sup>5</sup> 1/8" thick spacer 052364 replaces 1/4" spacer 041626 to provide proper spacing of blade guide block when using 1 1/4" blades.

## 2.6 Blade Guide Assembly, Idle Side (Block, Optional)

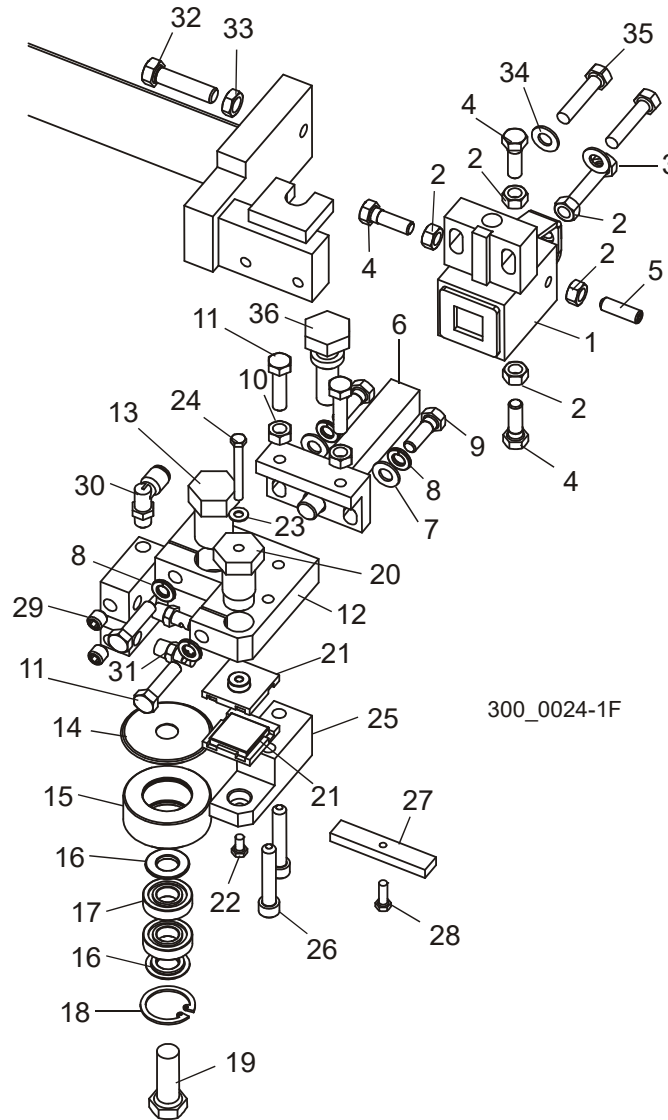

REF	DESCRIPTION (◆ Indicates Parts Available In Assemblies Only)	PART #	QTY.
	<b>GUIDE ASSEMBLY, IDLE SIDE BLOCK/ROLLER</b>	035200	1
	Block Assembly, Idle Side Blade Guide	036099 <sup>1</sup>	1
1	Block Weldment, Blade Guide Mount	035219 <sup>1</sup>	1 ◆
2	Nut, 5/16-18 Hex	F05010-17	5
3	Bolt, 5/16-18 x 1 1/2" Hex Head Full Thread Stainless Steel	F05006-119	1
4	Bolt, 5/16-18 x 1" Hex Head Stainless Steel	F05006-88	3
5	Screw, 5/16-18 x 1" Socket Head Flat Point Stainless Steel	F05006-122	1
6	Shaft Weldment, Block Guide Pivot	035209	1
7	Washer, 5/16" SAE Flat	F05011-17	2

# 2

## Blade Guides & Arm

### Blade Guide Assembly, Idle Side (Block, Optional)

8	Washer, 5/16" Split Lock	F05011-13	4	
9	Bolt, 5/16-18 x 1" Hex Head Stainless Steel	F05006-88	2	
10	Nut, 5/16-18 Hex	F05010-17	2	
11	Bolt, 5/16-18 x 1 1/4" Hex Head Stainless Steel	F05006-118	4	
12	Block Weldment, Upper Blade Guide	035206	1	
13	Bolt, Blade Guide Roller Mount	035215	1	
14	Hood, Blade Guide Back Roller	042848 <sup>2</sup>	1	
	Roller Assembly, Blade Guide	023977	1	
15	Housing, Blade Guide Roller	017223	1	◆
16	Spacer, Blade Guide Roller	018948	2	
17	Bearing, R8-2RS Blade Guide	015975	2	
18	Ring, 1 1/8" IR 3000x112 Retaining	F04254-1	1	
19	Bolt, 1/2-13 x 1 1/2" Hex Head	F05008-4	1	
20	Bolt, Blade Guide Block Mount	035216	1	
21	Block, Blade Guide Wear (Standard for 1 1/2" or 1 3/4" Blades)	052309 <sup>3</sup>	2	
	Block, Blade Guide Wear (Optional for 1 1/4" Blades)	052355 <sup>3</sup>	2	
	Disk Assembly, 1" Sq. EZ-Glide Wear	036347 <sup>3</sup>	2	
22	Screw, #10-32 x 3/8" Hex Head Stainless Steel	F05004-171	1	
23	Washer, #10 Brass	042867 <sup>4</sup>	1	
24	Bolt, #10-32 x 1 3/4" Hex Head Stainless Steel	F05004-178	1	
25	Block, Lower Blade Guide	035213	1	
26	Screw, 5/16-18 x 1 3/4" Socket Head	F05006-65	2	
27	Block, Blade Guide Alignment	035799	1	
28	Screw, #10-32 x 5/8" Hex Head	F05004-152	1	
29	Fitting, 1/8" NPT Socket Pipe Plug	P30127	2	
30	Fitting, 1/8" MPT x 1/4" Tube Swivel Elbow	P09736	1	
31	Fitting, Blade Lube Spray Nozzle	033479	2	
32	<b>BOLT, 3/8-16 X 1 1/2" HEX HEAD FULL THREAD</b>	F05007-17 <sup>5</sup>	1	
33	<b>NUT, 3/8-16 HEX JAM</b>	F05010-29	1	
34	<b>WASHER, 5/16" SAE FLAT</b>	F05011-17	2	
35	<b>BOLT, 5/16-18 X 1 1/2" HEX HEAD</b>	F05008-96	2	
36	<b>BOLT, BLADE GUIDE VERTICAL ADJUSTMENT</b>	035656	1	

<sup>1</sup> Mounting Block 035219 and adjustment hardware modified to be consistent with other models (Rev. A4.00). Use service assembly 036099 for block replacement.

<sup>2</sup> Hood added to prevent debris from entering roller assembly (Rev. A4.00).

<sup>3</sup> Blade guide wear blocks 052309 & 052355 replace EZ-Glide block 036347 to improve wear life (Rev. A9.00). 052309 blocks for use with 1 1/2" blades provided as standard equipment or optional 1 3/4" blades. 052355 blocks available for optional use with 1 1/4" blades. EZ-Glide blocks 036347 are available for customers who prefer this block. EZ-Glide pad assembly 036347 replaces Wear Pad assembly 042860 supplied prior to Rev. A6.00. New pad is cost effective and contributes to longer blade life. Square Disk Assembly replaces Round Disk Assembly 035222 (Rev. A4.00). Changing from round disks to square disks requires replacement of Item #25 bottom disk block 035213.

<sup>4</sup> Brass Washer 042867 added to improve guide disk adjustment.

<sup>5</sup> Replaces F05007-18 3/8-16 x 1 1/4" Oval Point Set Screw originally supplied (Rev. A7.02).

## 2.7 Blade Guide Assembly, Drive Side (Roller/Block, Standard)

LT300

Rev. B3.01

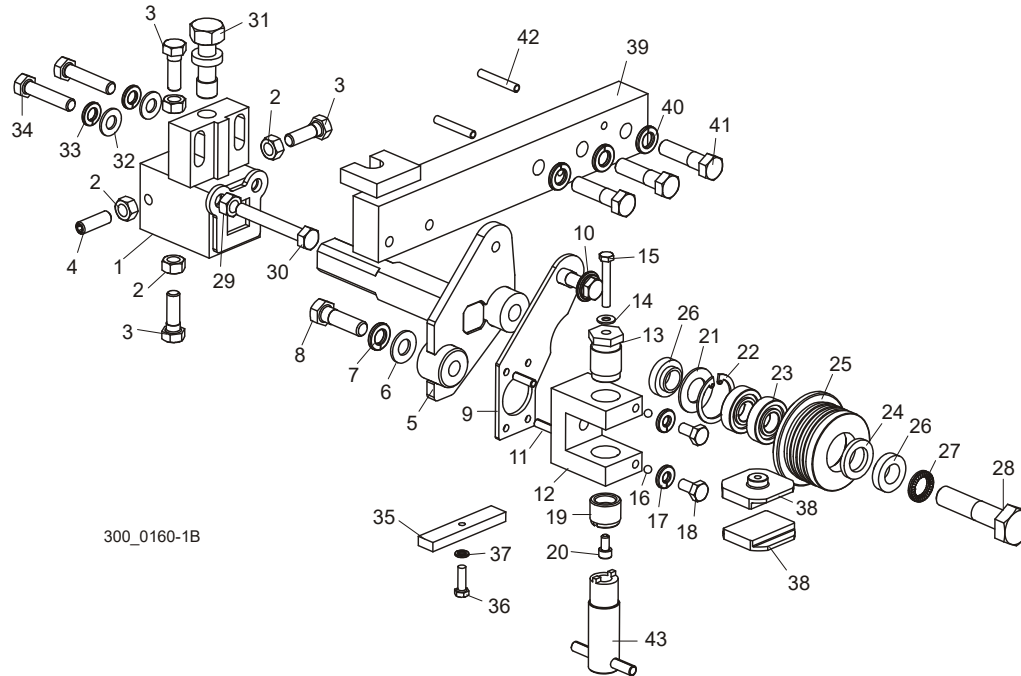

REF	DESCRIPTION (◆ Indicates Parts Available In Assemblies Only)	PART #	QTY.
	<b>ROLLER/BLOCK ASSEMBLY, DRIVE SIDE (INNER)</b>	003925 <sup>1</sup>	1
	Block Assembly, Blade Guide Mount	003910	1
1	Block Weldment, Blade Guide Mount	003911	1 ◆
2	Nut, 5/16-18 Hex	F05010-17	4
3	Bolt, 5/16-18 x 1" Hex Head Stainless Steel	F05006-88	3
4	Screw, 5/16-18 x 1" Socket Head Flat Point Stainless Steel Set	F05006-122	1
5	Shaft Weldment, Drive Side Guide	003913	1
	Mount Assembly, Blade Guide Block Drive	003927	1
6	Washer, 3/8" SAE Flat	F05011-3	1
7	Washer, 3/8" Split Lock	F05011-4	1
8	Bolt, 3/8-16 x 1 1/4" Hex Head Grade 5	F05007-123	1
9	Plate, Block Tilt Adjustment	003915	1
10	Bolt, 5/16-18 x 3/4" Hex Head w/Flat & Lock Washer	F05006-101	1
11	Pin, 3/16" x 5/8" Roll	F05012-22	2
12	Block, Guide Block Mount	003909	1
13	Bolt, Blade Guide Block Mount	003994	1
14	Washer, #10 Brass	042867	1
15	Bolt, #10-32 x 1 1/4" Hex Head Stainless Steel	F05004-240	1
16	Ball, 3/16" Dia. Nylon	003914	2
17	Washer, 1/4" Split Lock	F05011-14	2
18	Bolt, 1/4-20 x 1/2" Hex Head	F05005-15	2
19	Screw, Lower Block Adjustment	044057	1

## 2

**Blade Guides & Arm***Blade Guide Assembly, Drive Side (Roller/Block, Standard)*

20	Screw, #10-32 x 3/8" Socket Head Stainless Steel	F05004-200	1	
	Roller Assembly, Blade Guide (standard for use with 1 1/4" & 1 1/2" blades)	A04925 <sup>2</sup>	1	
	Roller Assembly, Extended Blade Guide (optional for use with 1 1/2" blades)	014299 <sup>2</sup>	1	
	Roller Assembly, Extended Blade Guide (optional for use with 1 3/4" blades)	057441 <sup>2</sup>	1	
	Bearing Kit, Blade Guide Rebuild	K07079 <sup>2</sup>	1	
21	Washer, 5/8" White Felt	P04252	1	
22	Ring, 1 1/8" Interior Retaining	F04254-1	1	
23	Bearing, R8-2RS Blade Guide	015975	2	◆
24	Washer, 5/8" Gray Felt	P06455	1	
	Screw, 1/4-28 x 1/4" Socket Head Cup Point Set Black Oxide	F05005-105	1	
	Instruction Sheet, Blade Guide Rebuild	057407-1507	1	
25	Roller, Flanged Blade Guide (1 1/4" & 1 1/2" blade)	S04250	1	◆
	Roller, Flanged Blade Guide (1 1/2" blade)	014243	1	◆
	Roller, Flanged Blade Guide (1 3/4" blade)	037598	1	◆
	Instruction Sheet, Blade Guide Roller Replacement	A04925-364	1	
26	Spacer, Blade Guide	S04253	2	
27	Washer, 1/2" Nord-Lock	F05011-125 <sup>3</sup>	1	
28	Bolt, 1/2-13 x 2 1/4" Hex Head Grade 5	F05008-10	1	
29	Nut, 5/16-18 Hex	F05010-17	1	
30	Bolt, 5/16-18 x 2 1/4" Hex Head Full Thread	F05006-16	1	
31	Bolt, Blade Guide Vertical Adjustment	035656	1	
32	Washer, 5/16" SAE Flat	F05011-17	2	
33	Washer, 5/16" Split Lock	F05011-13	2	
34	Bolt, 5/16-18 x 1 1/2" Hex Head	F05006-76	2	
35	<b>BLOCK, BLADE GUIDE ALIGNMENT</b>	035799	1	
36	<b>SCREW, #10-32 X 5/8" HEX HEAD</b>	F05004-152	1	
37	<b>WASHER, #10 SPLIT LOCK</b>	F05011-20	1	
38	<b>BLOCK, BLADE GUIDE WEAR (STANDARD FOR 1 1/2" OR 1 3/4" BLADES)</b>	052309 <sup>4</sup>	2	
	<b>BLOCK, BLADE GUIDE WEAR (OPTIONAL FOR 1 1/4" BLADES)</b>	052355 <sup>4</sup>	2	
	<b>BLOCK ASSEMBLY, 1" SQ. EZ-GLIDE WEAR</b>	036347 <sup>4</sup>	2	
39	<b>ARM WELDMENT, DRIVE SIDE BLADE GUIDE</b>	035658	1	
40	<b>WASHER, 3/8" SPLIT LOCK</b>	F05011-4	3	
41	<b>BOLT, 3/8-16 X 1 1/2" HEX HEAD GRADE 5</b>	F05007-78	3	
42	<b>PIN, 3/16" X 1 1/4" ROLL</b>	F05012-16	2	
43	<b>TOOL, LOWER BLOCK ADJUSTMENT</b>	044064	1	
	<b>SHIM, .008" BLADE GUIDE BLOCK SPACER</b>	035248	1	

<sup>1</sup> Roller/Block Assembly 003925 is no longer available. Use component parts to service or order Roller/Block Assembly 036812 for 1-1/4" blades or 065933 for 1-1/2" blades.

<sup>2</sup> The sawmill is equipped standard with blade guide rollers that can be used with the standard 1 1/2" blade. The roller can also be used with 1 1/4" blades. Optional extended blade guide rollers are available for use with 1 1/2" blades or 1 3/4". The extended rollers may provide more stability during difficult sawing, but will reduce the total amount of times the blade can be reused after sharpening. Order one additional Blade Guide Bearing 015975 in addition to K07079 Rebuild Kit to service 1 3/4" roller.

<sup>3</sup> Nord-Lock Washer F05011-125 replaced Split Lock Washer F05011-9 to prevent loosening due to vibration (Rev. B4.01).

## Blade Guides & Arm 2

*Blade Guide Assembly, Drive Side (Roller/Block, Standard)*

---

<sup>4</sup> 052309 blocks for use with 1 1/2" blade provided as standard equipment or optional 1 3/4" blade. 052355 blocks available for optional use with 1 1/4" blades. EZ-Glide blocks 036347 are available for customers who prefer this block.



## Blade Guides & Arm

Blade Guide Assembly, Drive Side (Roller/Block, Standard)

### 2.8 Blade Guide Assembly, Drive Side (Roller/Block, Standard)

LT300

Rev. A9.04 - B3.00

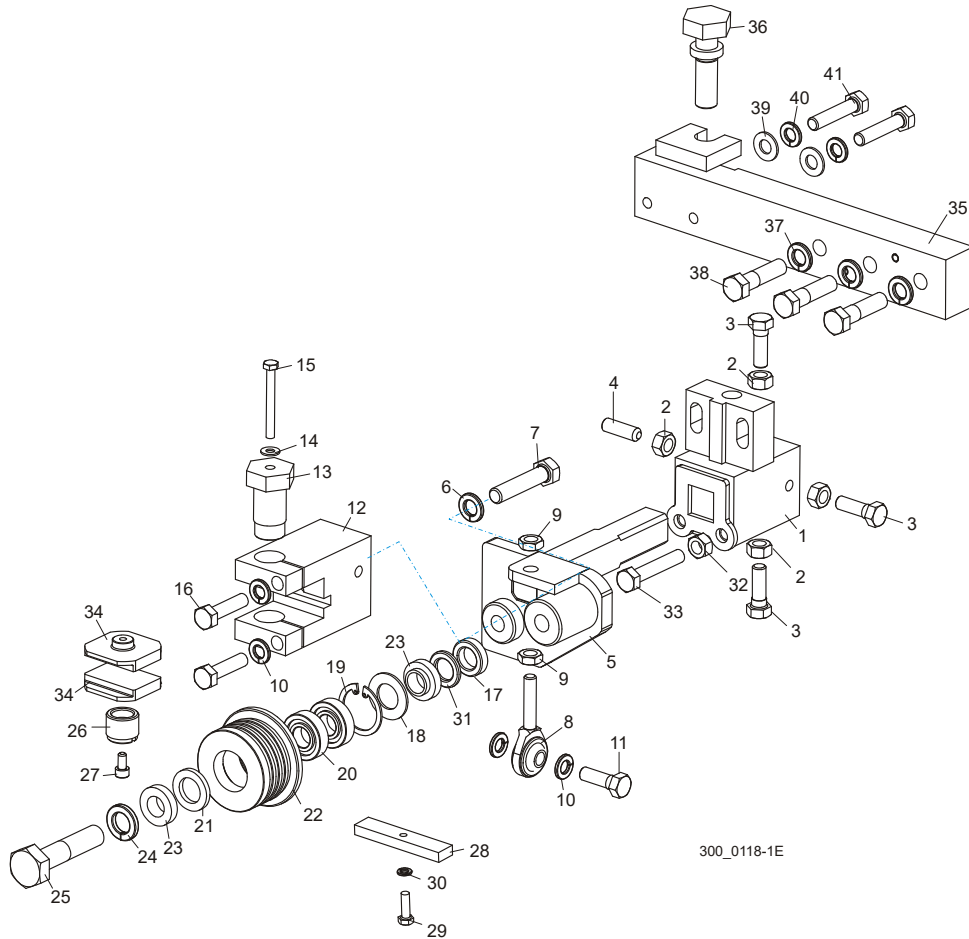

REF	DESCRIPTION (◆ Indicates Parts Available In Assemblies Only)	PART #	QTY.	
	<b>ROLLER/BLOCK ASSEMBLY, DRIVE SIDE (INNER)</b>	036812	1	◆
	Block Assembly, Blade Guide Mount	036867	1	
1	Block Weldment, Blade Guide Mount	036868	1	◆
2	Nut, 5/16-18 Hex	F05010-17	4	
3	Bolt, 5/16-18 x 1" Hex Head Stainless Steel	F05006-88	3	
4	Screw, 5/16-18 x 1" Socket Head Flat Point Stainless Steel Set	F05006-122	1	
5	Shaft Weldment, Drive Side Guide	036865	1	
6	Washer, 3/8" Split Lock	F05011-4	1	
7	Bolt, 3/8-16 x 1 3/4" Full Thread Hex Head Grade 5	F05007-129	1	
8	Rod End, 5/16-24 Male	P09814	1	
9	Nut, 5/16-24 Hex Jam	F05010-28	2	
10	Washer, 5/16" Split Lock	F05011-13	4	
11	Bolt, 5/16-18 x 1" Hex Head Stainless Steel	F05006-88	1	



12	Block, Guide Block Mount	036814	1	
13	Bolt, Blade Guide Block Mount	035216	1	
14	Washer, #10 Brass	042867	1	
15	Bolt, #10-32 x 1 3/4" Hex Head Stainless Steel	F05004-178	1	
16	Bolt, 5/16-18 x 1 1/4" Hex Head Stainless Steel	F05006-118	2	
17	Spacer, 1/2" ID x 7/8" OD x 1/4" (for 1 1/4" blades only)	041626 <sup>1</sup>	1	
	Roller Assembly, Blade Guide (standard for use with 1 1/4" & 1 1/2" blades)	A04925 <sup>2</sup>	1	
	Roller Assembly, Extended Blade Guide (optional for use with 1 1/2" blades)	014299 <sup>2</sup>	1	
	Roller Assembly, Extended Blade Guide (optional for use with 1 3/4" blades)	057441 <sup>2</sup>	1	
	Bearing Kit, Blade Guide Rebuild	K07079 <sup>2</sup>	1	
18	Washer, 5/8" White Felt	P04252	1	
19	Ring, 1 1/8" Interior Retaining	F04254-1	1	
20	Bearing, R8-2RS Blade Guide	015975	2	◆
21	Washer, 5/8" Gray Felt	P06455	1	
	Screw, 1/4-28 x 1/4" Socket Head Cup Point Set Black Oxide	F05005-105	1	
	Instruction Sheet, Blade Guide Rebuild	057407-1507	1	
22	Roller, Flanged Blade Guide (1 1/4" & 1 1/2" blade)	S04250	1	◆
	Roller, Flanged Blade Guide (1 1/2" blade)	014243	1	◆
	Roller, Flanged Blade Guide (1 3/4" blade)	037598	1	◆
	Instruction Sheet, Blade Guide Roller Replacement	A04925-364	1	
23	Spacer, Blade Guide	S04253	2	
24	Washer, 1/2" Split Lock	F05011-9 <sup>3</sup>	1	
25	Bolt, 1/2-13 x 2 1/4" Hex Head Grade 5	F05008-10	1	
26	Screw, Lower Block Adjustment	044057	1	
27	Screw, #10-32 x 3/8" Socket Head Stainless Steel	F05004-200	1	
28	Block, Blade Guide Alignment	035799	1	
29	Screw, #10-32 x 5/8" Hex Head	F05004-152	1	
30	Washer, #10 Split Lock	F05011-20	1	
31	Spacer, 1/2" ID x 7/8" OD x 1/8" Thick (for 1 1/2" blades only)	052364 <sup>1</sup>	1	
32	Nut, 5/16-18 Hex	F05010-17	1	
33	Bolt, 5/16-18 x 1 3/4" Hex Head Full Thread	F05006-17	1	
34	<b>BLOCK, BLADE GUIDE WEAR (STANDARD FOR 1 1/2" OR 1 3/4" BLADES)</b>	052309 <sup>4</sup>	2	
	<b>BLOCK, BLADE GUIDE WEAR (OPTIONAL FOR 1 1/4" BLADES)</b>	052355 <sup>4</sup>	2	
	<b>BLOCK ASSEMBLY, 1" SQ. EZ-GLIDE WEAR</b>	036347 <sup>4</sup>	2	
35	<b>ARM WELDMENT, DRIVE SIDE BLADE GUIDE</b>	035658	1	
36	<b>BOLT, BLADE GUIDE VERTICAL ADJUSTMENT</b>	035656	1	
37	<b>WASHER, 3/8" SPLIT LOCK</b>	F05011-4	3	
38	<b>BOLT, 3/8-16 X 1 1/2" HEX HEAD GRADE 5</b>	F05007-78	3	
	<b>SHIM, .008" CERAMIC INSERT SPACER</b>	035248	1	
39	<b>WASHER, 5/16" SAE FLAT</b>	F05011-17	2	
40	<b>WASHER, 5/16" SPLIT LOCK</b>	F05011-13	2	
41	<b>BOLT, 5/16-18 X 1 1/2" HEX HEAD STAINLESS STEEL</b>	F05006-119	2	

## 2

## Blade Guides & Arm

### *Blade Guide Assembly, Drive Side (Roller/Block, Standard)*

---

- <sup>1</sup> Use 1/8" spacer 052364 with 1 1/2" blade provided as standard equipment. Use 1/4" spacer 041626 for optional 1 1/4" blades.
- <sup>2</sup> The sawmill is equipped standard with blade guide rollers that can be used with the standard 1 1/2" blade. The roller can also be used with 1 1/4" blades. Optional extended blade guide rollers are available for use with 1 1/2" blades or 1 3/4". The extended rollers may provide more stability during difficult sawing, but will reduce the total amount of times the blade can be reused after sharpening. Order one additional Blade Guide Bearing 015975 in addition to K07079 Rebuild Kit to service 1 3/4" roller.
- <sup>3</sup> Nord-Lock Washer F05011-125 available to replace Split Lock Washer F05011-9 to prevent loosening due to vibration (12/09).
- <sup>4</sup> 052309 blocks for use with 1 1/2" blade provided as standard equipment or optional 1 3/4" blade. 052355 blocks available for optional use with 1 1/4" blades. EZ-Glide blocks 036347 are available for customers who prefer this block (requires spacer 052364 for use with 1 1/4" blades). Blocks removed from blade guide assembly BOM to allow structuring of blade guide assembly in various equipment (11/05).

## 2.9 Blade Guide Assembly, Drive Side (Roller/Block, Standard)

LT300

Rev. A1.00 - A9.03

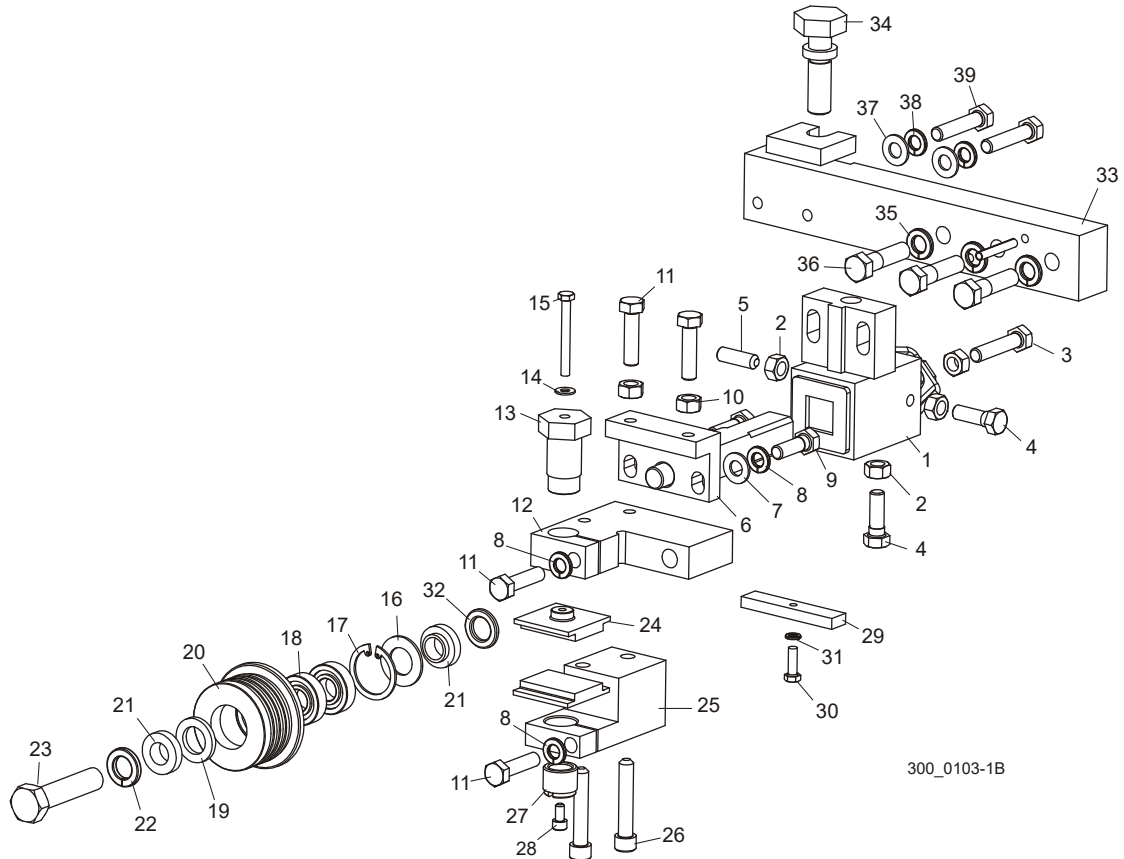

300\_0103-1B

REF	DESCRIPTION (◆ Indicates Parts Available In Assemblies Only)	PART #	QTY.	
	<b>ROLLER/BLOCK ASSEMBLY, DRIVE SIDE (INNER)</b>	044050 <sup>1</sup>	1	◆
	Block Assembly, Blade Guide Mount	036100	1	
1	Block Weldment, Blade Guide Mount	035219	1	◆
2	Nut, 5/16-18 Hex	F05010-17	5	
3	Bolt, 5/16-18 x 1 1/2" Hex Head Full Thread Stainless Steel	F05006-119	1	
4	Bolt, 5/16-18 x 1" Hex Head Stainless Steel	F05006-88	3	
5	Screw, 5/16-18 x 1" Socket Head Flat Point Stainless Steel Set	F05006-122	1	
6	Shaft Weldment, Block Guide Pivot	035209	1	
7	Washer, 5/16" SAE Flat	F05011-17	2	
8	Washer, 5/16" Split Lock	F05011-13	4	
9	Bolt, 5/16-18 x 1" Hex Head Stainless Steel	F05006-88	2	
10	Nut, 5/16-18 Hex	F05010-17	2	
11	Bolt, 5/16-18 x 1 1/4" Hex Head Stainless Steel	F05006-118	4	
12	Block, Upper Blade Guide	044051	1	
13	Bolt, Blade Guide Block Mount	035216	1	

## 2

**Blade Guides & Arm***Blade Guide Assembly, Drive Side (Roller/Block, Standard)*

14	Washer, #10 Brass	042867	1	
15	Bolt, #10-32 x 1 3/4" Hex Head Stainless Steel	F05004-178	1	
	Roller Assembly, Blade Guide (standard for use with 1 1/4" & 1 1/2" blades)	A04925 <sup>2</sup>	1	
	Roller Assembly, Extended Blade Guide (optional for use with 1 1/2" blades)	014299 <sup>2</sup>	1	
	Roller Assembly, Extended Blade Guide (optional for use with 1 3/4" blades)	057441 <sup>2</sup>	1	
	Bearing Kit, Blade Guide Rebuild	K07079 <sup>2</sup>	1	
16	Washer, 5/8" White Felt	P04252	1	
17	Ring, 1 1/8" Interior Retaining	F04254-1	1	
18	Bearing, R8-2RS Blade Guide	015975	2	◆
19	Washer, 5/8" Gray Felt	P06455	1	
	Screw, 1/4-28 x 1/4" Socket Head Cup Point Set Black Oxide	F05005-105	1	
	Instruction Sheet, Blade Guide Rebuild	057407-1507	1	
20	Roller, Flanged Blade Guide (1 1/4" & 1 1/2" blade)	S04250	1	◆
	Roller, Flanged Blade Guide (1 1/2" blade)	014243	1	◆
	Roller, Flanged Blade Guide (1 3/4" blade)	037598	1	◆
	Instruction Sheet, Blade Guide Roller Replacement	A04925-364	1	
21	Spacer, Blade Guide	S04253	2	
22	Washer, 1/2" Split Lock	F05011-9 <sup>3</sup>	1	
23	Bolt, Blade Guide Roller Mount	036399	1	
24	Block, Blade Guide Wear (Standard for 1 1/2" or 1 3/4" Blades)	052309 <sup>4</sup>	2	
	Block, Blade Guide Wear (Optional for 1 1/4" Blades)	052355 <sup>4</sup>	2	
	Block Assembly, 1" Sq. EZ-Glide Wear	036347 <sup>4</sup>	2	
25	Block, Lower Blade Guide	044052	1	
26	Screw, 5/16-18 x 1 3/4" Socket Head	F05006-65	2	
27	Screw, Lower Block Adjustment	044057	1	
28	Screw, #10-32 x 3/8" Socket Head Stainless Steel	F05004-200	1	
29	Block, Blade Guide Alignment	035799	1	
30	Screw, #10-32 x 5/8" Hex Head	F05004-152	1	
31	Washer, #10 Split Lock	F05011-20	1	
32	Spacer, 1/2" ID x 7/8" OD x 1/8" Thick (for 1 1/4" blades only)	052364 <sup>5</sup>	1	
33	<b>ARM WELDMENT, DRIVE SIDE BLADE GUIDE</b>	035658	1	
34	<b>BOLT, BLADE GUIDE VERTICAL ADJUSTMENT</b>	035656	1	
35	<b>WASHER, 3/8" SPLIT LOCK</b>	F05011-4	3	
36	<b>BOLT, 3/8-16 X 1 1/2" HEX HEAD GRADE 5</b>	F05007-78	3	
	<b>SHIM, .008" CERAMIC INSERT SPACER</b>	035248	1	
37	<b>WASHER, 5/16" SAE FLAT</b>	F05011-17	2	
38	<b>WASHER, 5/16" SPLIT LOCK</b>	F05011-13	2	
39	<b>BOLT, 5/16-18 X 1 1/2" HEX HEAD STAINLESS STEEL</b>	F05006-119	2	

<sup>1</sup> 044050 Blade Guide Assembly replaced with 036812 Rev. A9.04 and no longer available. Use component parts to service or replace entire assembly with 036812. New assembly provides easier adjustment ([See Section 2.8](#)).

- <sup>2</sup> The sawmill is equipped standard with blade guide rollers that can be used with the standard 1 1/2" blade. The roller can also be used with 1 1/4" blades. Optional extended blade guide rollers are available for use with 1 1/2" blades or 1 3/4". The extended rollers may provide more stability during difficult sawing, but will reduce the total amount of times the blade can be reused after sharpening. Order one additional Blade Guide Bearing 015975 in addition to K07079 Rebuild Kit to service 1 3/4" roller.
- <sup>3</sup> Nord-Lock Washer F05011-125 available to replace Split Lock Washer F05011-9 to prevent loosening due to vibration (12/09).
- <sup>4</sup> Blade guide wear blocks 052309 & 052355 replace EZ-Glide block 036347 to improve wear life (Rev. A9.00). 052309 blocks for use with 1 1/2" blade provided as standard equipment or optional 1 3/4" blade. 052355 blocks available for optional use with 1 1/4" blades. EZ-Glide blocks 036347 are available for customers who prefer this block (requires spacer 052364 for use with 1 1/4" blades).
- <sup>5</sup> 1/8" thick spacer 052364 replaces 1/4" spacer 041626 to provide proper spacing of blade guide block when using 1 1/4" blades.

# 2

## Blade Guides & Arm

Blade Guide Assembly, Drive Side (Block, Optional)

### 2.10 Blade Guide Assembly, Drive Side (Block, Optional)

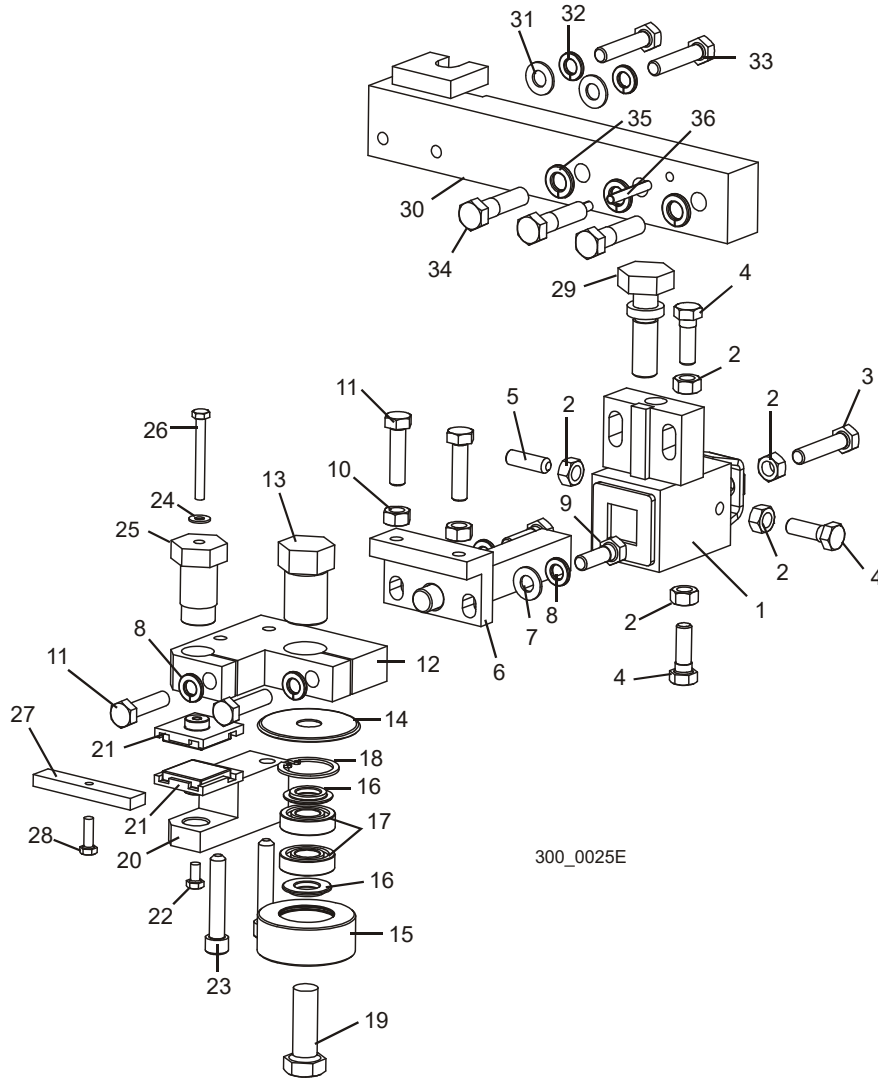

REF	DESCRIPTION (◆ Indicates Parts Available In Assemblies Only)	PART #	QTY.	
	<b>GUIDE ASSEMBLY, DRIVE SIDE BLOCK/ROLLER</b>	035201	1	
	Block Assembly, Blade Guide Mount	036100 <sup>1</sup>	1	
1	Block Weldment, Blade Guide Mount	035219 <sup>1</sup>	1	◆
2	Nut, 5/16-18 Hex	F05010-17	5	
3	Bolt, 5/16-18 x 1 1/2" Hex Head Full Thread Stainless Steel	F05006-119	1	
4	Bolt, 5/16-18 x 1" Hex Head Stainless Steel	F05006-88	3	
5	Screw, 5/16-18 x 1" Socket Head Flat Point Stainless Steel Set	F05006-122	1	
6	Shaft Weldment, Block Guide Pivot	035209	1	
7	Washer, 5/16" SAE Flat	F05011-17	2	
8	Washer, 5/16" Split Lock	F05011-13	4	

## Blade Guides & Arm 2

*Blade Guide Assembly, Drive Side (Block, Optional)*

9	Bolt, 5/16-18 x 1" Hex Head Stainless Steel	F05006-88	2	
10	Nut, 5/16-18 Hex	F05010-17	2	
11	Bolt, 5/16-18 x 1 1/4" Hex Head Stainless Steel	F05006-118	4	
12	Block Weldment, Upper Blade Guide	035207	1	
13	Bolt, Blade Guide Roller Mount	035215	1	
14	Hood, Blade Guide Back Roller	042848 <sup>2</sup>	1	
	Roller Assembly, Blade Guide	023977	1	
15	Housing, Blade Guide Roller	017223	1	◆
16	Spacer, Blade Guide Roller	018948	2	
17	Bearing, R8-2RS Blade Guide	015975	2	
18	Ring, 1 1/8" IR 3000x112 Retaining	F04254-1	1	
19	Bolt, 1/2-13 x 1 1/2" Hex Head	F05008-4	1	
20	Block, Lower Blade Guide	035214	1	
21	Block, Blade Guide Wear (Standard for 1 1/2" or 1 3/4" Blades)	052309 <sup>3</sup>	2	
	Block, Blade Guide Wear (Optional for 1 1/4" Blades)	052355 <sup>3</sup>	2	
	Disk Assembly, 1" Sq. EZ-Glide Wear	036347 <sup>3</sup>	2	
22	Screw, #10-32 x 3/8" Hex Head Stainless Steel	F05004-171	1	
23	Screw, 5/16-18 x 1 3/4" Socket Head	F05006-65	2	
24	Washer, #10 Brass	042867 <sup>4</sup>	1	
25	Bolt, Blade Guide Block Mount	035216	1	
26	Bolt, #10-32 x 1 3/4" Hex Head Stainless Steel	F05004-178	1	
27	Block, Blade Guide Alignment	035799	1	
28	Screw, #10-32 x 5/8" Hex Head	F05004-152	1	
29	<b>BOLT, BLADE GUIDE VERTICAL ADJUSTMENT</b>	035656	1	
30	<b>ARM WELDMENT, DRIVE SIDE BLADE GUIDE MOUNT</b>	074987	1	
31	<b>WASHER, 5/16" SAE FLAT</b>	F05011-17	2	
32	<b>WASHER, 5/16" SPLIT LOCK</b>	F05011-13	2	
33	<b>BOLT, 5/16-18 X 1 1/2" HEX HEAD FULL THREAD STAINLESS STEEL</b>	F05006-119	2	
34	<b>BOLT, 1/2-20 X 1 1/2" HEX HEAD GRADE 5</b>	F05008-53	3	
35	<b>WASHER, 1/2" SPLIT LOCK</b>	F05011-9	3	
36	<b>PIN, 3/16" X 1 1/4" ROLL</b>	F05012-16	2	

<sup>1</sup> Mounting Block 035219 and adjustment hardware modified to be consistent with other models (Rev. A4.00). Use service assembly 036100 for block replacement.

<sup>2</sup> Hood added to prevent debris from entering roller assembly (Rev. A4.00).

<sup>3</sup> Blade guide wear blocks 052309 & 052355 replace EZ-Glide block 036347 to improve wear life (Rev. A9.00). 052309 blocks for use with 1 1/2" blades provided as standard equipment or optional 1 3/4" blade. 052355 blocks available for optional use with 1 1/4" blades. EZ-Glide blocks 036347 are available for customers who prefer this block. EZ-Glide pad assembly 036347 replaces Wear Pad assembly 042860 supplied prior to Rev. A6.00. New pad is cost effective and contributes to longer blade life. Square Disk Assembly replaces Round Disk Assembly 035222 (Rev. A4.00). Changing from round disks to square disks requires replacement of Item #20 bottom disk block 035214.

<sup>4</sup> Brass Washer 042867 added to improve guide disk adjustment.

# 2 Blade Guide Rollers & Arm

## Blade Guide Arm

### 2.11 Blade Guide Arm

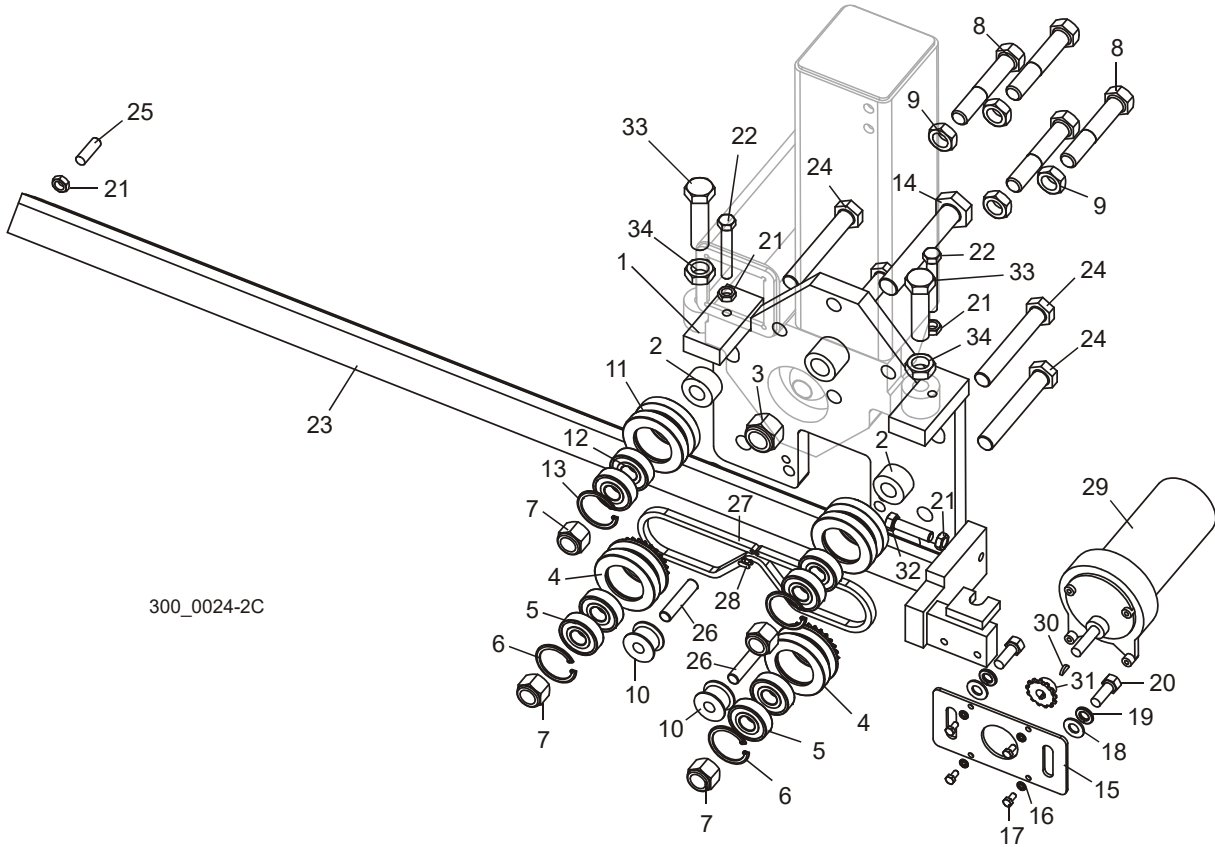

REF	DESCRIPTION (◆ Indicates Parts Available In Assemblies Only)	PART #	QTY.	
	<b>PLATE ASSEMBLY, BLADE GUIDE ARM (LT300/WM3000)</b>	042540	1	
	Blade Guide Parts ( <a href="#">See Section 2.6</a> )			
1	Plate Weldment, Blade Guide Arm	042539	1	
2	Spacer, .625" x .717" x 1 1/4"	042531	4	
3	Nut, 3/4-16 Hex Nylon Lock	F05010-157	1	
	Roller Assembly, Blade Guide Arm Drive	042542	2	
4	Roller, Blade Guide Arm W/Sprocket	042541	1	◆
5	Bearing, 5/8" x 1.5748" x .4724"	P06030-1	2	
6	Ring, 1.575" ID Beveled 5002-156 Retaining	F04254-8	1	
7	Nut, 5/8-18 Hex Nylon Lock	F05010-71	4	
8	Bolt, 5/8-16 x 3 1/2" Hex Head Full Thread	F05009-16	4	
9	Nut, 5/8-18 Hex Jam	F05010-11	4	
10	Roller, Chain Idler	S09999	2	
	Roller Assembly, Blade Guide Arm Idle	042543	2	
11	Roller, 2 1/2" V-Groove	042536	1	◆
12	Bearing, 5/8" x 1.5748" x .4724"	P06030-1	2	



13	Ring, 1.575" ID Beveled 5002-156 Retaining	F04254-8	1	
14	Bolt, 3/4-16 x 4 1/2" Hex Head Grade 8	F05009-97	1	
15	Plate, Blade Guide Arm Motor Mount	042519	1	
16	Washer, #10 Split Lock	F05011-20	4	
17	Screw, #10-32 x 1/2" Hex Head Machine	F05004-60	4	
18	Washer, 3/8" SAE Flat	F05011-3	2	
19	Washer, 3/8" Split Lock	F05011-4	2	
20	Bolt, 3/8-16 x 1" Hex Head	F05007-7	2	
21	Nut, 3/8-16 Hex Jam	F05010-29	3	
22	Bolt, 3/8-16 x 2 1/2" Hex Head Full Thread Grade 2	F05007-157	2	
23	Arm Weldment, Blade Guide	023962	1	
24	Bolt, 5/8-18 x 3 1/4" Hex Head Grade 5	F05009-98	4	
25	Screw, 3/8-16 x 1 1/4" Socket Head Oval Point Set	F05007-18	1	
26	Pin, 7/16" x 2" Dowel	F05012-110	2	
27	Chain, #25 x 92 Pitch	042443	1	
28	Link, #25 Master	P09983	1	
29	Motor Assembly, 24V 60RPM Gear	035659	1	
	Motor, 24V 1/15HP Gear	033119	1	
	Housing, Klauber Motor End	P12756	1	
	Shaft, Blade Guide Arm Gear Motor	036514	1	
	Gear Kit, Blade Guide Arm Gear Motor	036515	1	
30	Key, #304 Woodruff	036203	1	
31	Sprocket, 25B13x 3/8" w/Set Screw	033120	1	
32	Bolt, 3/8-16 x 1 1/2" Hex Head Full Thread	F05007-17	1	
33	<b>BOLT, 5/8-18 X 2 1/2" HEX HEAD FULL THREAD GRADE 5</b>	F05009-99	2	
34	<b>NUT, 5/8-18 HEX JAM</b>	F05010-11	2	

## SECTION 3 BLADE WHEELS & TENSIONER

### 3.1 Drive Shaft Assembly

LT300

Rev. A8.00+

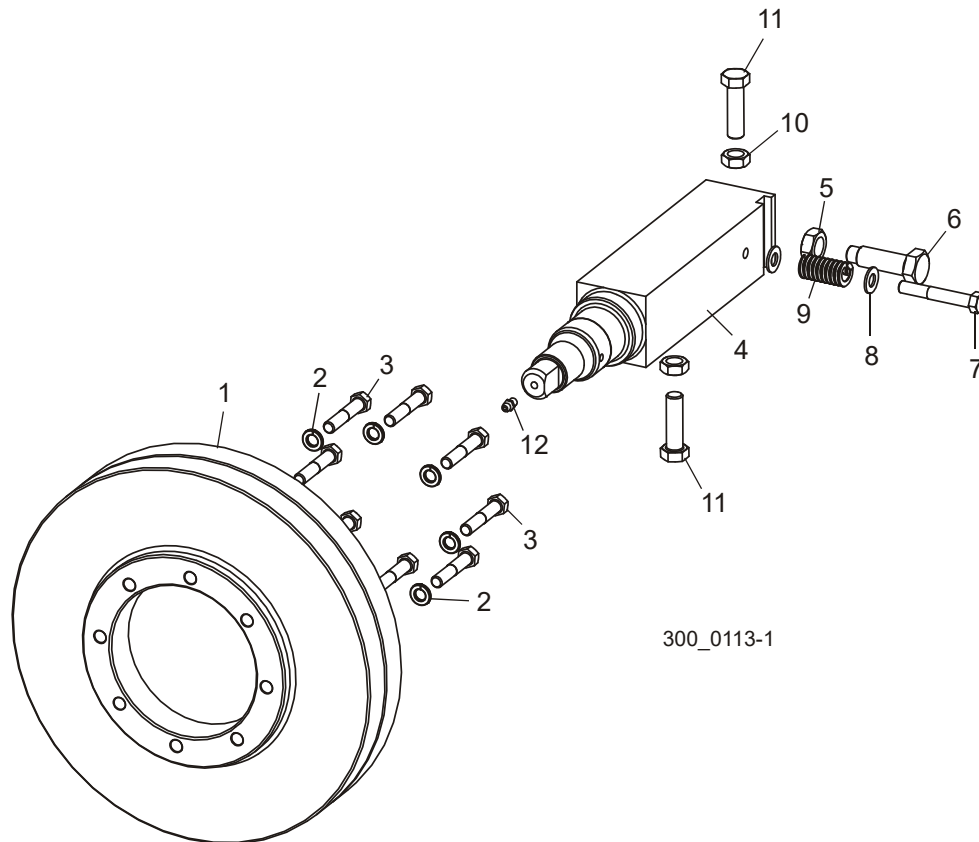

REF	DESCRIPTION (◆ Indicates Parts Available In Assemblies Only)	PART #	QTY.
1	SHEAVE, EAGLE PD DRIVE	046897 <sup>1</sup>	1
2	WASHER, 3/8" SPLIT LOCK	F05011-4	8
3	BOLT, 3/8-16 X 2" HEX HEAD GRADE 5	F05007-124	8
4	SHAFT, BLADE WHEEL	017824	1
5	BOLT, DRIVE WHEEL SHAFT RETAINING	034360	1
6	NUT, 5/8-18 HEX JAM	F05010-11	1
7	BOLT, 3/8-16 X 2 1/2" HEX HEAD	F05007-47	1
8	WASHER, 3/8" SAE FLAT	F05011-3	2
9	SPRING, 3/4" OD X 1 1/2" DIE	034430	1
10	BOLT, 1/2-20 X 1 3/4" HEX HEAD FULL THREAD	F05008-127	2
11	NUT, 1/2-20 HEX JAM	F05010-16	2
12	FITTING, 1/4-28 GREASE	P05060	1

<sup>1</sup> Drive Retrofit 036679 (60Hz) or 003233 (50Hz) includes parts to upgrade revisions prior to Rev. A8.00.

### 3.2 Drive Shaft Assembly

LT300

Rev. A4.00 - A7.02

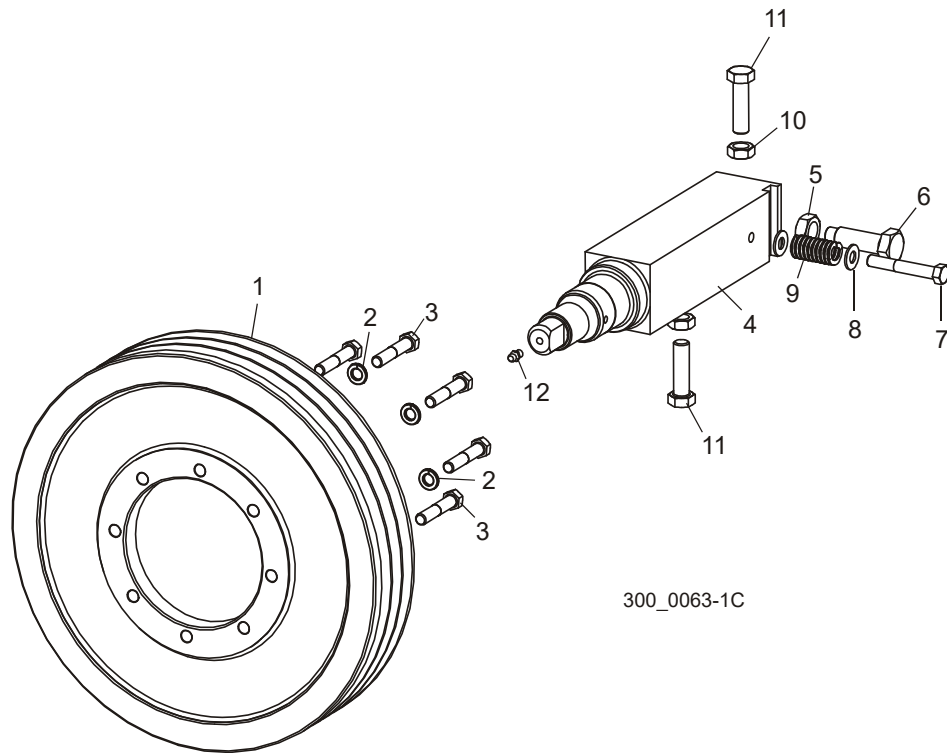

300\_0063-1C

REF	DESCRIPTION (◆ Indicates Parts Available In Assemblies Only)	PART #	QTY.	
1	SHEAVE, DRIVE	045098 <sup>1</sup>	1	◆
2	WASHER, 3/8" SPLIT LOCK	F05011-4	8	
3	BOLT, 3/8-16 X 2" HEX HEAD GRADE 5	F05007-124	8	
4	SHAFT, BLADE WHEEL	017824	1	
5	BOLT, DRIVE WHEEL SHAFT RETAINING	034360	1	
6	NUT, 5/8-18 HEX JAM	F05010-11	1	
7	BOLT, 3/8-16 X 2 1/2" HEX HEAD	F05007-47	1	
8	WASHER, 3/8" SAE FLAT	F05011-3	2	
9	SPRING, 3/4" OD X 1 1/2" DIE	034430	1	
10	BOLT, 1/2-20 X 1 3/4" HEX HEAD FULL THREAD	F05008-127	2	
11	NUT, 1/2-20 HEX JAM	F05010-16	2	
12	FITTING, 1/4-28 GREASE	P05060	1	

<sup>1</sup> Drive Sheave 045098 no longer available. Upgrade drive system to Eagle PD system to improve power transmission. Use retrofit kit 036679 (60Hz) or 003233 (50Hz) to upgrade LT300 prior to Rev. A8.00 ([See Section 3.1](#)).

# 3 Blade Wheels & Tensioner

## Drive Shaft Assembly

### 3.3 Drive Shaft Assembly

LT300

Rev. A1.00 - A3.00

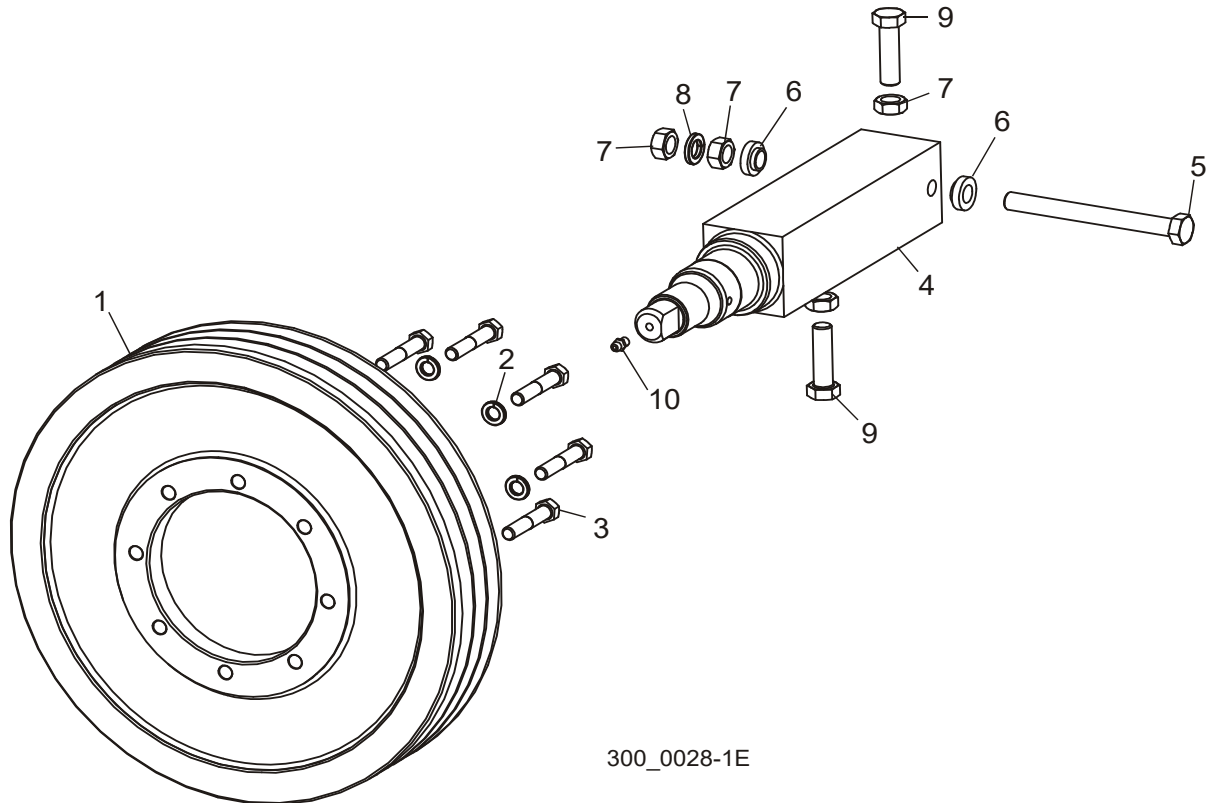

REF	DESCRIPTION (◆ Indicates Parts Available In Assemblies Only)	PART #	QTY.
1	SHEAVE, DRIVE	045098 <sup>1</sup>	1
2	WASHER, 3/8" SPLIT LOCK	F05011-4	8
3	BOLT, 3/8-16 X 2" HEX HEAD GRADE 5	F05007-124	8
4	SHAFT, BLADE WHEEL	033244 <sup>2</sup>	1
5	BOLT, 1/2-20 X 5" HEX HEAD FULL THREAD	F05008-125 <sup>2</sup>	1
6	SPACER, .510" X .937" X .34" FLANGED	S04253 <sup>2</sup>	2
7	NUT, 1/2-20 HEX JAM	F05010-16 <sup>2</sup>	4
8	WASHER, 1/2" SPLIT LOCK	F05011-9 <sup>2</sup>	1
9	BOLT, 1/2-20 X 1 3/4" HEX HEAD FULL THREAD	F05008-127 <sup>2</sup>	2
10	FITTING, 1/4-28 GREASE	P05060	1

<sup>1</sup> Drive Sheave 045098 no longer available. Upgrade drive system to Eagle PD system to improve power transmission. Use retrofit kit 036679 (60Hz) or 003233 (50Hz) to upgrade LT300 prior to Rev. A8.00 ([See Section 3.1](#)).

<sup>2</sup> Drive Shaft and Cant Adjust Hardware revised Rev. A4.00 ([See Section 3.2](#)).

### 3.4 Idle Shaft/Brake Drum

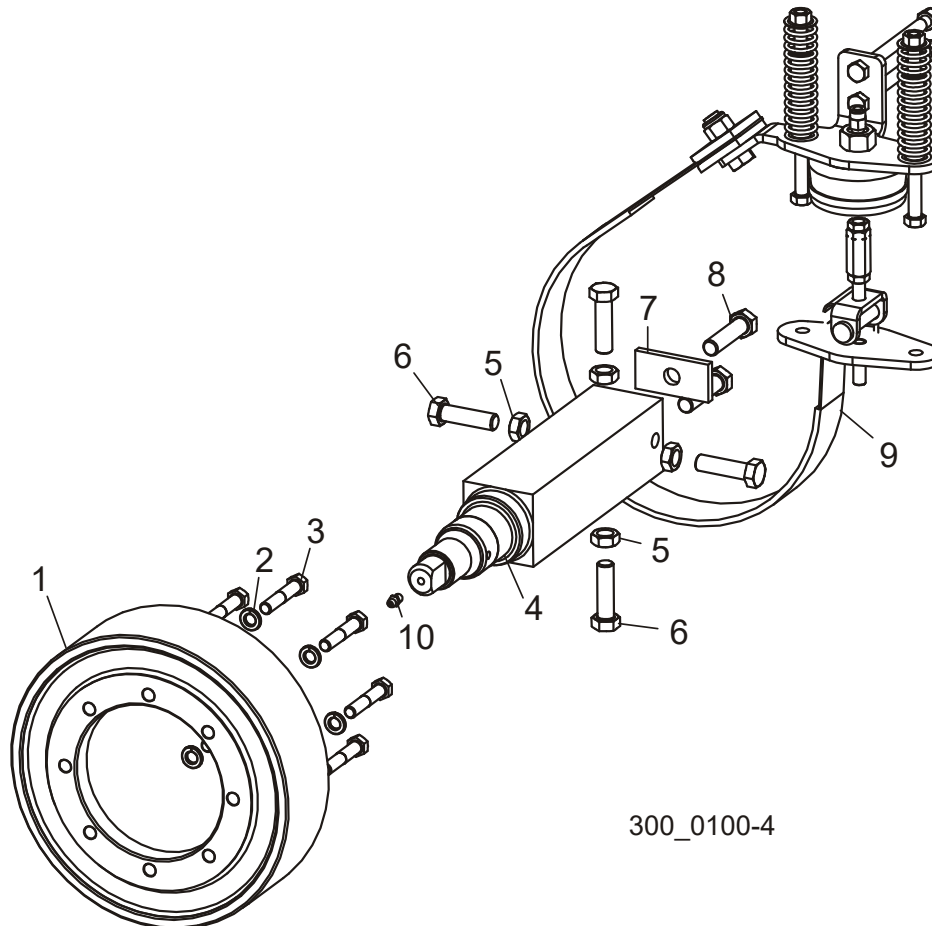

300\_0100-4

REF	DESCRIPTION (◆ Indicates Parts Available In Assemblies Only)	PART #	QTY.
1	DRUM, BRAKE	045004	1
2	WASHER, 3/8" SPLIT LOCK	F05011-4	8
3	BOLT, 3/8-16 X 1 3/4" HEX HEAD GRADE 5	F05007-119	8 <sup>1</sup>
4	SHAFT, BLADE WHEEL	033244	1
5	NUT, 1/2-20 HEX JAM	F05010-16	4
6	BOLT, 1/2-20 X 1 3/4" HEX HEAD FULL THREAD	F05008-127	4
7	PLATE, WASHER	042548	1
8	BOLT, 1/2-20 X 2" HEX HEAD FULL THREAD	F05008-126	2
9	BRAKE ACTUATOR & STRAP PARTS ( <a href="#">See Section 3.7</a> )		
10	FITTING, 1/4-28 GREASE	P05060	1

<sup>1</sup> 1 3/4" bolt F05007-119 replaces 2" bolts F05007-124 2/08. 2" bolts may bottom out before proper tightening torque achieved.

# 3 Blade Wheels & Tensioner

## Blade Wheel Kit, Belted (Standard)

### 3.5 Blade Wheel Kit, Belted (Standard)

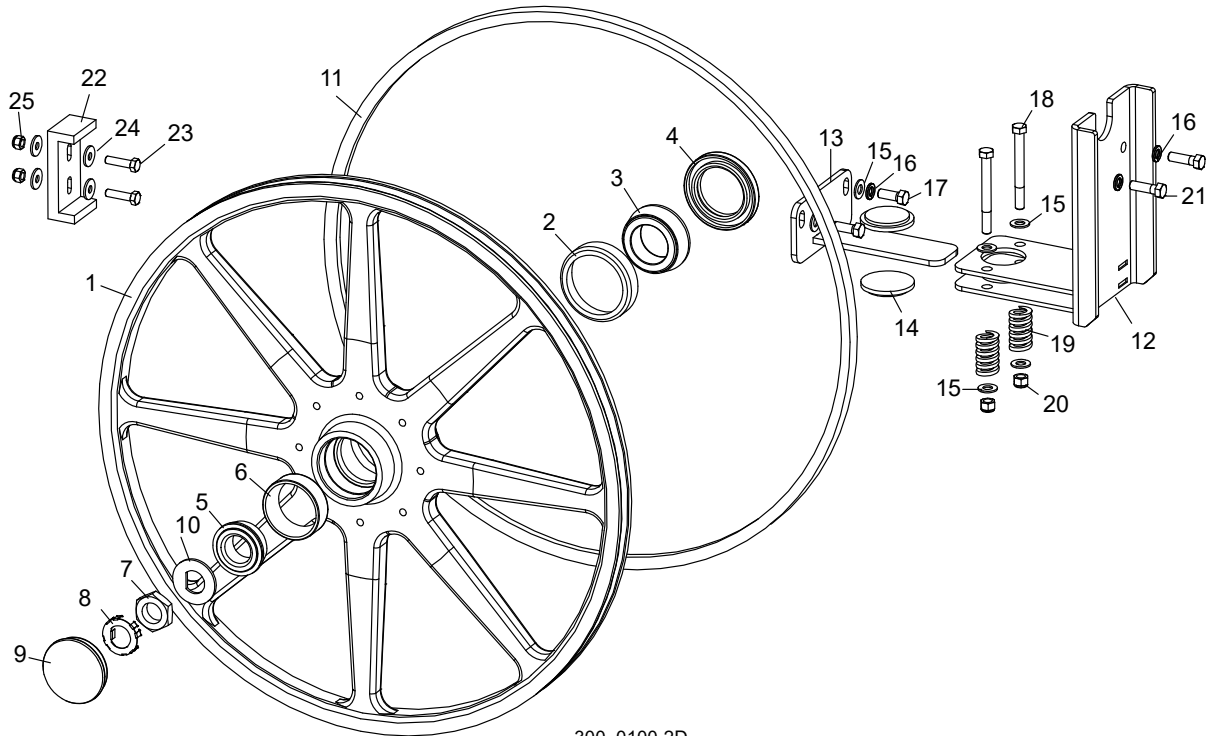

300\_0100-2D

REF	DESCRIPTION (◆ Indicates Parts Available In Assemblies Only)	PART #	QTY.	
	<b>WHEEL KIT, BELTED BLADE</b>	036704 <sup>1</sup>	1	◆
	Wheel Assembly, Belted Blade w/Bearings	036632	2	
1	Wheel, 25" Belted Blade	036619	1	◆
	Bearing Kit, Blade Wheel	061227	1	
2	Race, Inner Bearing	045209	1	
3	Bearing, Inner	045208	1	
4	Seal, Blade Wheel Bearing	045212	1	
5	Bearing, Outer	045210	1	
6	Race, Outer Bearing	045211	1	
	Nut Assembly, Spindle w/Retainer	007656 <sup>2</sup>	1	
7	Nut, 1-14 Spindle	007654	1	◆
8	Retainer, Spindle Nut	007655	1	◆
9	Cap, Hub Dust	033238	1	
10	Washer, Blade Wheel Shaft D	045214	1	
11	Belt, B75.5	035953-1 <sup>3</sup>	1	
	Dampener Kit, Anti-Vibration	036840 <sup>4</sup>	1	
12	Mount Weldment, Dampener Pad	036838	1	
13	Tab Weldment, Dampener	036839	1	

## Blade Wheels & Tensioner

### *Blade Wheel Kit, Belted (Standard)*

3

14	Pad, Dampener	036833	2	
15	Washer, 3/8" SAE Flat	F05011-3	6	
16	Washer, 3/8" Split Lock	F05011-4	4	
17	Bolt, 3/8-16 x 1" Hex Head Grade 5	F05007-87	2	
18	Bolt, 3/8-16 x 3 1/2" Hex Head Grade 5	F05004-123	2	
19	Spring, 1" OD x 1/2" ID x 1 3/4" Heavy Die	036849	2	
20	Nut, 3/8-16 Hex Nylon Lock	F05010-10	2	
21	Bolt, 3/8-16 x 1 1/4" Hex Head Grade 5	F05007-123	2	
	Support Kit, Middle Blade	038493 <sup>5</sup>	1	
22	Support Channel, Middle Blade	038491	1	
23	Bolt, 5/16-18 x 1 1/4" Stainless Steel hex Head	F05006-118	2	
24	Washer, 5/16" Flat	F05011-16	4	
25	Nut, 5/16-18 Hex Nylon Lock	F05010-58	2	

<sup>1</sup> Belted blade wheels and block/roller blade guides provided standard on LT300 Rev. A8.00. [See Section 3.6](#) for optional crowned blade wheels used with all-block blade guides. Blade wheels are too heavy to ship together in kit 036704. Order 036632 separately for service. To convert to crowned steel wheels and all-block blade guides, use two 017814 crowned wheel assemblies and one 036706 block blade guide kit.

<sup>2</sup> Nut Assembly 007656 replaces Castle Nut P22776 and Dexter Tang Washer P22686 (10/09). Old nut and retainer no longer available and are not interchangeable with the new nut or retainer. Replace nut and retainer with assembly 007656. Also use to replace Nut 045216 originally supplied prior to Rev. A9.05 discontinued by vendor.

<sup>3</sup> 035953-1 B75.5 Belt replaces 035953 supplied prior to 7/10. New belt provides longer service life. Belt 035953 changed from B76 to B75.5 with additional backing to prevent belt damage when blade breaks and improve belt life.

<sup>4</sup> Dampener Kit added for machines equipped with belted blade wheels to eliminate motor vibration. Requires new side guard and mount bracket ([See Section 4.7](#)). Use kit 036841 to upgrade previous revisions.

<sup>5</sup> Blade Support Kit 038493 added Rev. A9.03 for LT300 equipped with belted wheels to prevent blade from vibrating during operation and increase blade life.

# 3 Blade Wheels & Tensioner

Blade Wheel Kit, Crowned (Optional)

## 3.6 Blade Wheel Kit, Crowned (Optional)

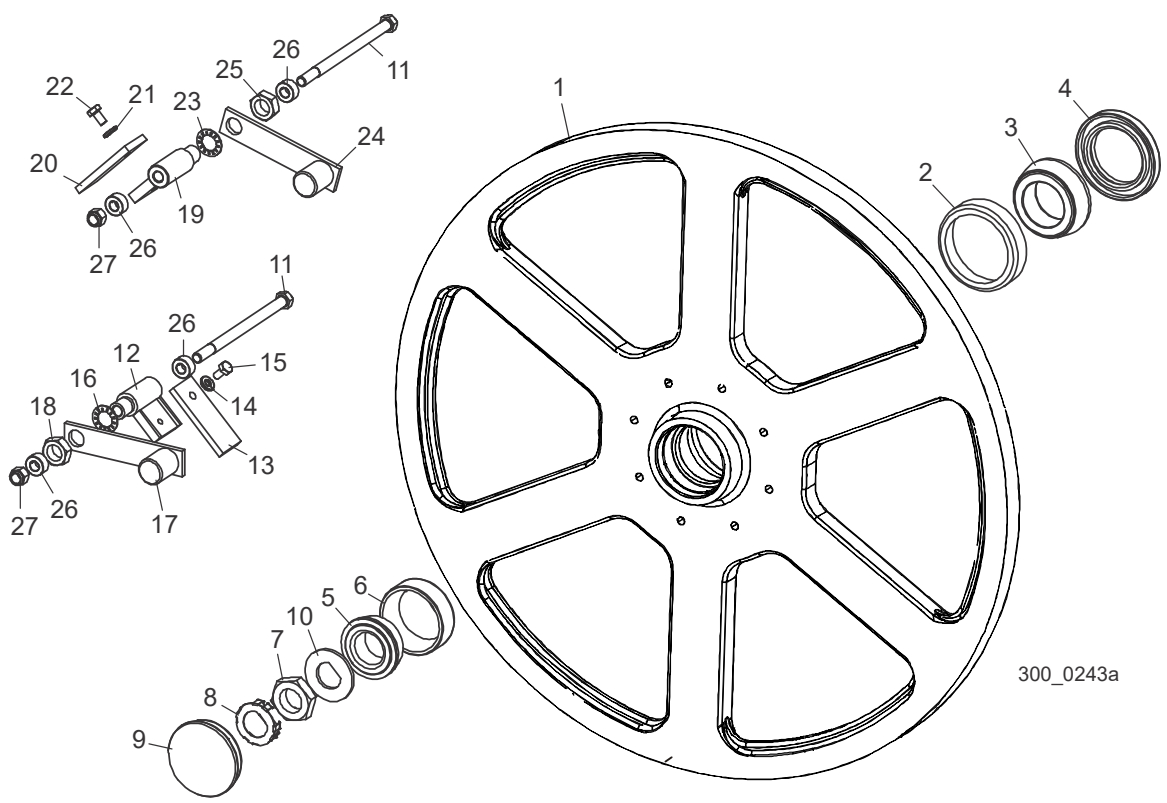

300\_0243a

REF	DESCRIPTION (◆ Indicates Parts Available In Assemblies Only)	PART #	QTY.	
	<b>WHEEL KIT, CROWNED BLADE (TWO COMPLETE BLADE WHEELS)</b>	036703 <sup>1</sup>	1	◆
	Wheel Assembly, Blade w/Bearings	017814 <sup>2</sup>	2	
1	Wheel, 25" Cast Blade	045000	1	◆
	Bearing Kit, Blade Wheel	061227	1	
2	Race, Inner Bearing	045209	1	
3	Bearing, Inner	045208	1	
4	Seal, Blade Wheel Bearing	045212	1	
5	Bearing, Outer	045210	1	
6	Race, Outer Bearing	045211	1	
	Nut Assembly, Spindle w/Retainer	007656 <sup>3</sup>	1	
7	Nut, 1-14 Spindle	007654	1	◆
8	Retainer, Spindle Nut	007655	1	◆
9	Cap, Hub Dust	033238	1	
10	Washer, Blade Wheel Shaft D	045214	1	
11	Bolt, 3/8-16 x 6" Hex Head	F05007-45	2	
	Scraper Assembly, Drive Side Blade Wheel	042247	1	
12	Pivot Weldment, Wheel Scraper	042240	1	



## Blade Wheels & Tensioner

### *Blade Wheel Kit, Crowned (Optional)*

3

13	Scraper, Brass Wheel	042245	1	
14	Washer, 1/4" Split Lock	F05011-14	1	
15	Bolt, 1/4-20 x 1/2" Hex Head	F05005-15	1	
16	Washer, 5/8" Interior Star Lock	F05011-25	1	
17	Weight Weldment, Wheel Scraper	042248	1	
18	Nut, 5/8-11 Hex Jam	F05010-82	1	
	Scraper Assembly, Idle Side Blade Wheel	042246	1	
19	Pivot Weldment, Wheel Scraper	042240	1	
20	Scraper, Brass Wheel	042245	1	
21	Washer, 1/4" Split Lock	F05011-14	1	
22	Bolt, 1/4-20 x 1/2" Hex Head	F05005-15	1	
23	Washer, 5/8" Interior Star Lock	F05011-25	1	
24	Weight Weldment, Wheel Scraper	042248	1	
25	Nut, 5/8-11 Hex Jam	F05010-82	1	
26	Collar, 3/8" ID	042249	4	
27	Nut, 3/8-16 Hex Nylon Lock	F05010-10	2	

<sup>1</sup> Belted blade wheels and block/roller blade guides provided standard on LT300 Rev. A8.00. [See Section 3.5](#) for standard belted blade wheels used with block/roller blade guides. Blade wheels are too heavy to ship together in kit 036703. Order 017814 separately for service. To convert to belted blade wheels and roller/block blade guides, use two 036632 belted wheel assemblies, one 036705 roller/block blade guide kit, one 038493 blade support kit and one 036841 vibration dampening retrofit (WM3000/WM3500 Rev. A1.00 - A8.00) or one 036840 vibration dampening kit (WM3000/WM3500 Rev. A9.00+ and WM4000 Rev. A1.00+).

<sup>2</sup> Dust Cap 033238, D Washer 045214 and Spindle Nut 045216 added to assembly 017814 (11/04).

<sup>3</sup> Nut Assembly 007656 replaces Castle Nut P22776 and Dexter Tang Washer P22686 (10/09). Old nut and retainer no longer available and are not interchangeable with the new nut or retainer. Replace nut and retainer with assembly 007656. Also use to replace Nut 045216 originally supplied prior to Rev. A9.05 discontinued by vendor.

### 3.7 Brake Assembly

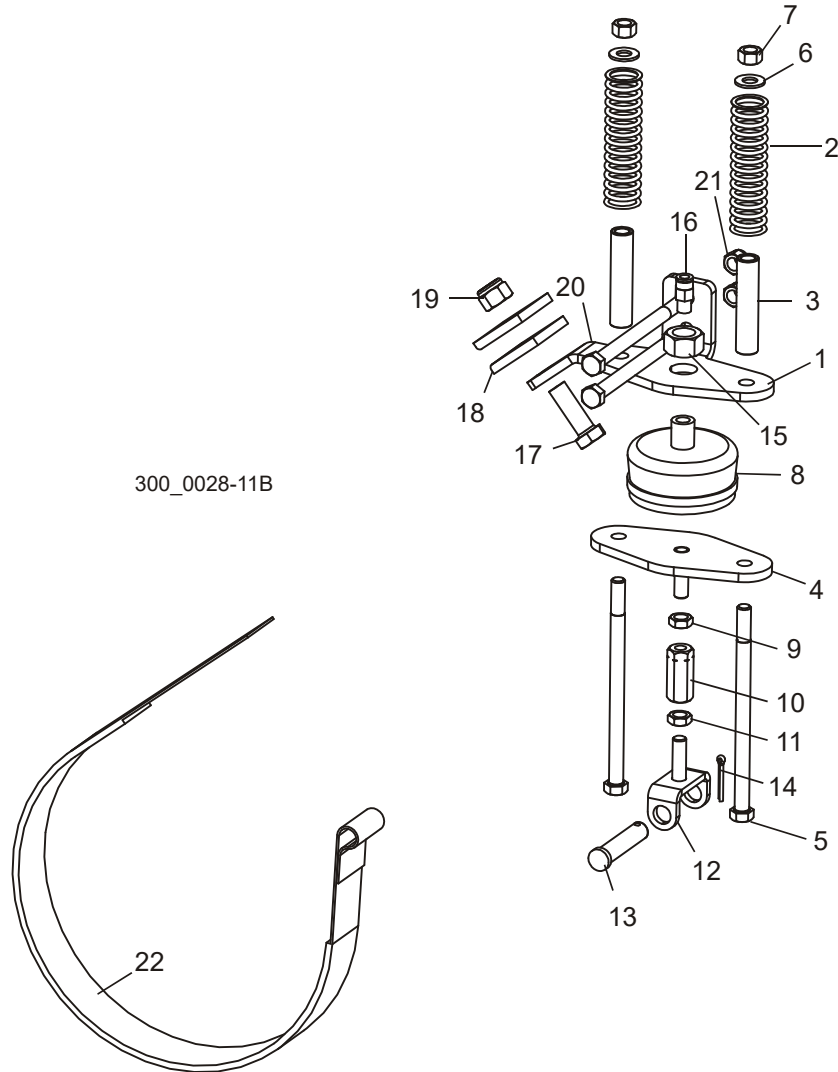

300\_0028-11B

REF	DESCRIPTION (◆ Indicates Parts Available In Assemblies Only)	PART #	QTY.
	<b>ACTUATOR ASSEMBLY, LT300 BRAKE</b>	033170	1
1	Bracket, Upper Brake Mount	033166	1
2	Spring, Brake	033171	2
3	Spacer, Brake Spring Travel	033169	2
4	Bracket Weldment, Lower Brake Mount	033172	1
5	Bolt, 3/8-16 x 6" Hex Head	F05007-45	2
6	Washer, 3/8" SAE Flat	F05011-3	2
7	Nut, 3/8-16 Hex Lock	F05010-25	2
8	Bag, Brake Air	033168	1
9	Nut, 3/8-24 Hex Jam (Left-Hand Thread)	F05010-166	1

## Blade Wheels & Tensioner

### *Brake Assembly*

**3**

<b>10</b>	Adjuster, Brake Link	033174	1	
<b>11</b>	Nut, 3/8-24 Hex Jam	F05010-22	1	
<b>12</b>	Bracket Weldment, Brake Link	033175	1	
<b>13</b>	Pin, 1/2" x 2 1/4" Clevis	F05012-81	1	
<b>14</b>	Pin, 1/8" x 1" Cotter	F05012-1	1	
<b>15</b>	Nut, 5/8-11 Hex	F05010-5	1	
<b>16</b>	Fitting, 1/8" NPT x 1/4" Tube	P03078	1	
<b>17</b>	Bolt, 1/2-13 x 1 1/2" Hex Head	F05008-4	1	
<b>18</b>	Plate, Brake Strap Clamp	S04195	2	
<b>19</b>	Nut, 1/2-13 Hex Nylon Lock	F05010-8	1	
<b>20</b>	Bolt, 3/8-16 x 5" Hex Head Grade 2	F05007-5	2	
<b>21</b>	Nut, 3/8-16 Hex Nylon Lock	F05010-10	2	
<b>22</b>	Strap, 9 1/2" Dia. Brake	033178	1	

# 3 Blade Wheels & Tensioner

## Blade Motor Drive Assembly

### 3.8 Blade Motor Drive Assembly

LT300

Rev. A8.00+

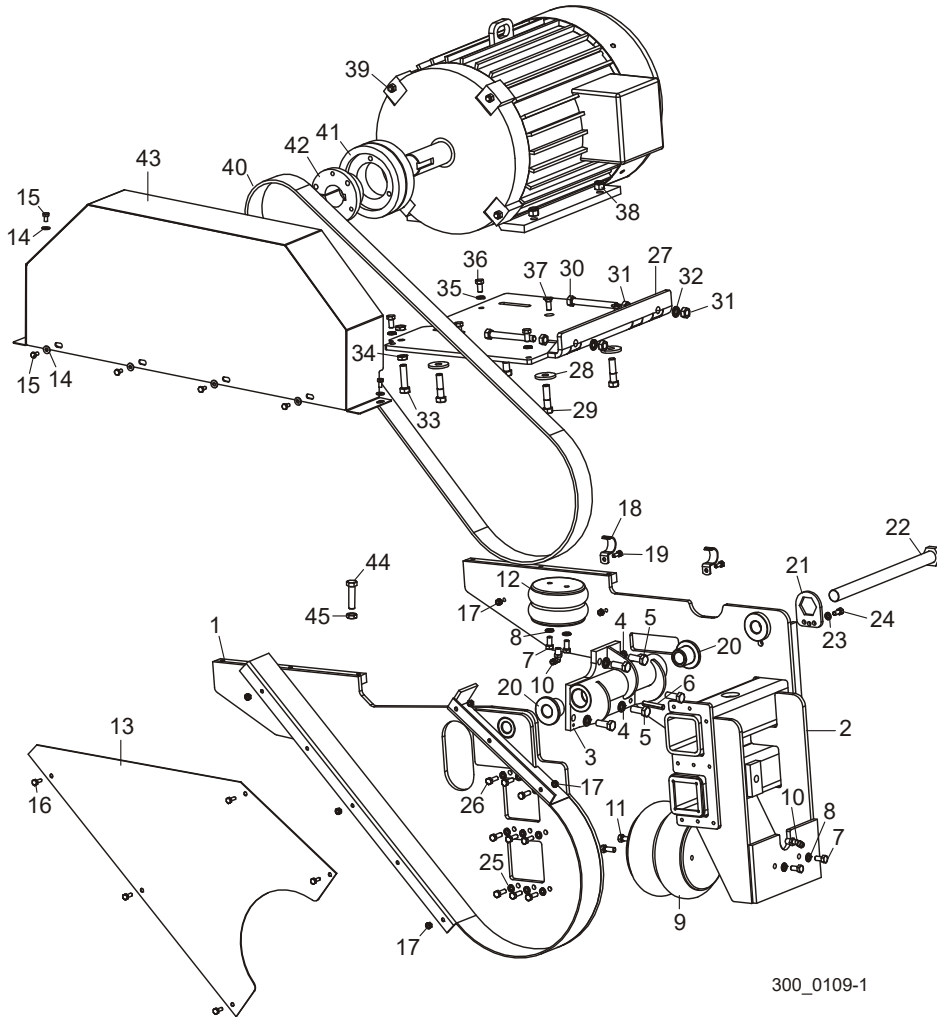

300\_0109-1

REF	DESCRIPTION (◆ Indicates Parts Available In Assemblies Only)	PART #	QTY.
1	BRACKET WELDMENT, FRONT MOTOR MOUNT	033211	1
2	BRACKET WELDMENT, REAR MOTOR MOUNT	033216	1
3	PIVOT WELDMENT, MOTOR MOUNT	033206	1
4	WASHER, 1/2" SPLIT LOCK	F05011-9	5
5	BOLT, 1/2-13 X 1 1/4" HEX HEAD GRADE 5	F05008-37	5
6	PIN, 3/8" X 2" ROLL	F05012-42	2
7	BOLT, 3/8-16 X 3/4" HEX HEAD GRADE 2	F05007-27	4
8	WASHER, 3/8" SPLIT LOCK	F050011-4	4
9	BAG, TENSIONER AIR	033229	1
10	FITTING, 1/4" NPT X 1/4" AIR 90 ELBOW	P21519	2
11	BOLT, 3/8-16 X 1" HEX HEAD GRADE 5	F05007-87	2

# Blade Wheels & Tensioner

## Blade Motor Drive Assembly

# 3

12	<b>BAG, MOTOR LIFT AIR</b>	033231	1	
13	<b>COVER, BELT</b>	036662	1	
14	<b>BOLT, 1/4-20 X 1/2" HEX HEAD</b>	F05005-15	5	
15	<b>WASHER, 1/4" SAE FLAT</b>	F05011-11	5	
16	<b>BOLT, 1/4-20 X 3/4" HEX HEAD</b>	F05005-129	5	
17	<b>NUT, 1/4-20 SELF-LOCKING HEX</b>	F05010-9	7	
18	<b>CLAMP, 1" EMT</b>	P05436	2	
19	<b>BOLT, 1/4-20 X 3/4" HEX HEAD FULL THREAD</b>	F05005-1	2	
20	<b>BEARING, MOTOR PIVOT</b>	033210	2	
21	<b>PLATE, PIVOT BOLT LOCK</b>	033230	1	
22	<b>BOLT WELDMENT, MOTOR PIVOT</b>	033225	1	
23	<b>WASHER, 5/16" SPLIT LOCK</b>	F05011-13	1	
24	<b>BOLT, 5/16-18 X 3/4" HEX HEAD</b>	F05006-5	1	
25	<b>WASHER, 5/16" SPLIT LOCK</b>	F05011-13	9	
26	<b>BOLT, 5/16-18 X 1" HEX HEAD GRADE 5</b>	F05006-48	9	
	<b>DRIVE ASSEMBLY, 30HP 480V/60HZ PD</b>	036638	1	
	<b>DRIVE ASSEMBLY, 30HP 480V/50HZ PD</b>	036640 <sup>1</sup>	1	
27	Plate Weldment, Motor Mount	042461	1	
28	Washer, .52" ID x 1.69" OD	014632	4	
29	Bolt, 1/2-13 x 2" Hex Head	F05008-76	4	
30	Bolt, 1/2-13 x 4 1/2" Hex Head Full Thread	F05008-16	2	
31	Nut, 1/2-13 Hex	F05010-35	4	
32	Washer, 1/2" Split Lock	F05011-9	2	
33	Bolt, 1/2-13 x 2" Hex Head Full Thread	F05008-8	1	
34	Nut, 1/2-13 Hex Jam	F05010-31	2	
35	Washer, 3/8" Split Lock	F05011-4	4	
36	Bolt, 3/8-16 x 3/4" Hex Head Grade 2	F05007-27	4	
37	Bolt, 3/8-16 x 1" Flat Socket Head	F05007-64	2	
38	Nut, 1/2-13 Hex Nylon Lock	F05010-8	4	
39	Motor, 30HP 1800RPM	042301	1	
40	Belt, Eagle PD G2380	036636 <sup>2</sup>	1	
41	Pulley, Eagle PD G36SSF	036634 <sup>2</sup>	1	
	Pulley, Eagle PD G45SE (50Hz)	036635	1	
42	Bushing, SF x 1 7/8"	039266 <sup>2</sup>	1	
	Bushing, E x 1 7/8" (50Hz)	036637 <sup>1</sup>	1	
43	Cover Weldment, Belt Guard	036678 <sup>3</sup>	1	
44	<b>BOLT, 1/2-13 X 2" HEX HEAD FULL THREAD</b>	F05008-8	1	
45	<b>NUT, 1/2-13 HEX JAM</b>	F05010-31	1	

<sup>1</sup> Alternate drive belt, motor pulley and bushing for 50Hz operation.

<sup>2</sup> Drive Retrofit 036679 includes parts to upgrade revisions prior to Rev. A8.00.

<sup>3</sup> Pulley Guard Weldment 036678 replaces 033165 supplied prior to Rev. A9.00. New guard will accommodate both 60Hz and 50Hz drive systems.

### 3.9 Blade Motor Drive Assembly

LT300

Rev. A7.00 - A7.03

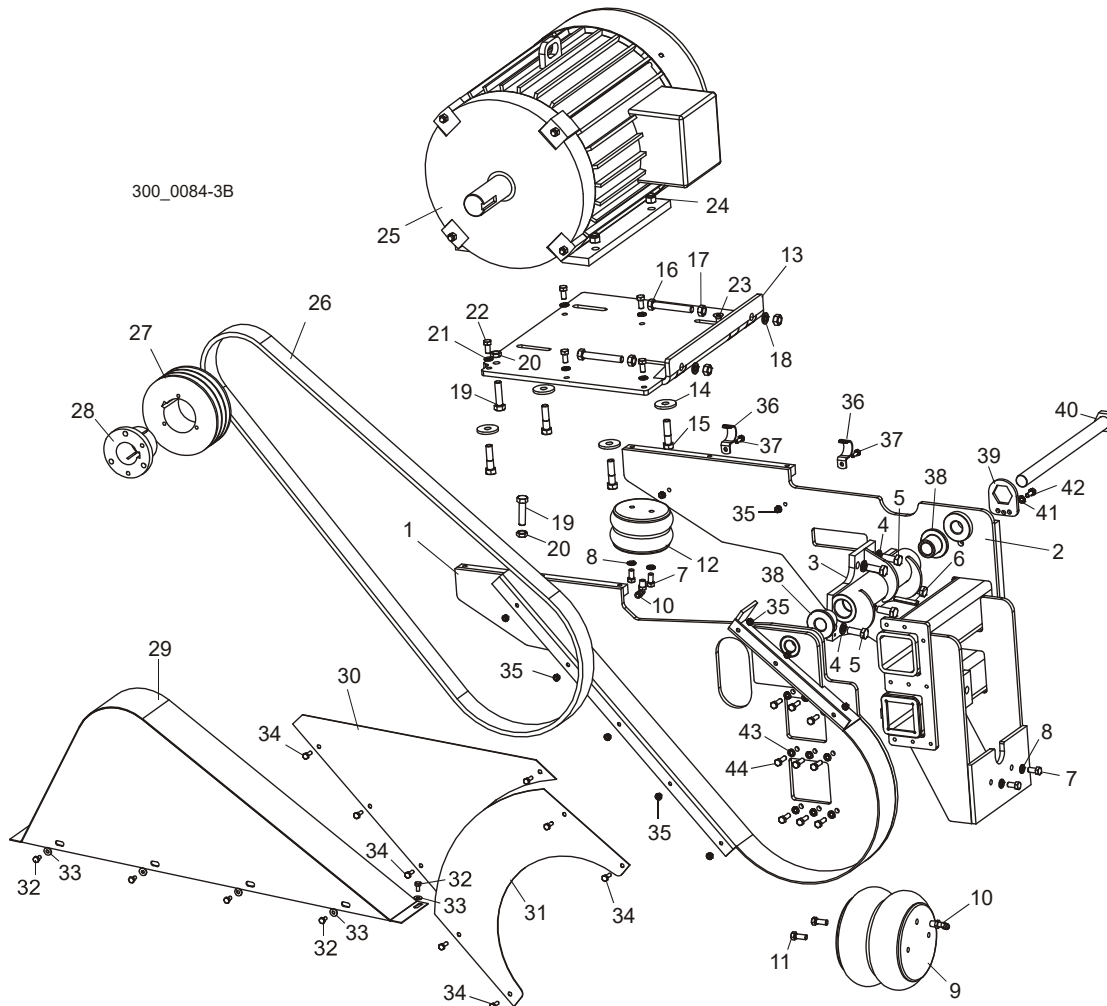

REF	DESCRIPTION (◆ Indicates Parts Available In Assemblies Only)	PART #	QTY.
1	BRACKET WELDMENT, FRONT MOTOR MOUNT	033211	1
2	BRACKET WELDMENT, REAR MOTOR MOUNT	033216	1
3	PIVOT WELDMENT, MOTOR MOUNT	033206	1
4	WASHER, 1/2" SPLIT LOCK	F05011-9	5
5	BOLT, 1/2-13 X 1 1/4" HEX HEAD GRADE 5	F05008-37	5
6	PIN, 3/8" X 2" ROLL	F05012-42	2
7	BOLT, 3/8-16 X 3/4" HEX HEAD GRADE 2	F05007-27	4
8	WASHER, 3/8" SPLIT LOCK	F050011-4	4
9	BAG, TENSIONER AIR	033229	1
10	FITTING, 1/4" NPT X 1/4" AIR 90 ELBOW	P21519	2
11	BOLT, 3/8-16 X 1" HEX HEAD GRADE 5	F05007-87	2
12	BAG, MOTOR LIFT AIR	033231	1

13	PLATE WELDMENT, MOTOR MOUNT	042461	1	
14	WASHER, .52" ID X 1.69" OD	014632	4	
15	BOLT, 1/2-13 X 2" HEX HEAD	F05008-76	4	
16	BOLT, 1/2-13 X 3 1/2" HEX HEAD	F05008-11	2	
17	NUT, 1/2-13 HEX	F05010-35	4	
18	WASHER, 1/2" SPLIT LOCK	F05011-9	2	
19	BOLT, 1/2-13 X 2" HEX HEAD FULL THREAD	F05008-8	2	
20	NUT, 1/2-13 HEX JAM	F05010-31	3	
21	WASHER, 3/8" SPLIT LOCK	F05011-4	5	
22	BOLT, 3/8-16 X 3/4" HEX HEAD GRADE 2	F05007-27	5	
23	BOLT, 3/8-16 X 1" FLAT SOCKET HEAD	F05007-64	1	
24	NUT, 1/2-13 HEX NYLON LOCK	F05010-8	4	
25	MOTOR, 30HP 1800RPM	042301	1	
26	BELT, 3/5VX950 DRIVE	045190 <sup>1</sup>	1	
	BELT, 3/5VXFL975 (50HZ)	036109 <sup>2</sup>	1	
27	PULLEY, 3/5V MOTOR DRIVE	045189 <sup>3</sup>	1	◆
	PULLEY, 3R5V80 MOTOR DRIVE (50HZ)	036110 <sup>4</sup>	1	◆
28	BUSHING, Q1 X 1 7/8"	042353	1	
	BUSHING, R1 X 1 7/8" (50HZ)	036111 <sup>2</sup>	1	
29	COVER WELDMENT, BELT GUARD	033165 <sup>5</sup>	1	◆
30	COVER, UPPER BELT	045050	1	
31	COVER, LOWER BELT	045034	1	
32	BOLT, 1/4-20 X 1/2" HEX HEAD	F05005-15	5	
33	WASHER, 1/4" SAE FLAT	F05011-11	5	
34	BOLT, 1/4-20 X 3/4" HEX HEAD	F05005-129	8	
35	NUT, 1/4-20 SELF-LOCKING HEX	F05010-9	10	
36	CLAMP, 1" EMT	P05436	2	
37	BOLT, 1/4-20 X 3/4" HEX HEAD FULL THREAD	F05005-1	2	
38	BEARING, MOTOR PIVOT	033210	2	
39	PLATE, PIVOT BOLT LOCK	033230	1	
40	BOLT WELDMENT, MOTOR PIVOT	033225	1	
41	WASHER, 5/16" SPLIT LOCK	F05011-13	1	
42	BOLT, 5/16-18 X 3/4" HEX HEAD	F05006-5	1	
43	WASHER, 5/16" SPLIT LOCK	F05011-13	9	
44	BOLT, 5/16-18 X 1" HEX HEAD GRADE 5	F05006-48	9	

<sup>1</sup> Drive may be retrofitted with Eagle PD system to improve power transmission. Use retrofit kit 036679 (60Hz) to upgrade LT300 prior to Rev. A8.00 ([See Section 3.8](#)).

<sup>2</sup> Alternate drive belt, motor pulley and bushing for 50Hz operation. All three parts included in kit 036108. Use retrofit kit 003233 (50Hz) to upgrade LT300 prior to Rev. A8.00 ([See Section 3.8](#)).

<sup>3</sup> Motor Pulley 045189 no longer available. Upgrade drive system to Eagle PD system to improve power transmission. Use retrofit kit 036679 (60Hz) to upgrade LT300 prior to Rev. A8.00 ([See Section 3.8](#)).

<sup>4</sup> Motor Pulley 036110 no longer available. Upgrade drive system to Eagle PD system to improve power transmission. Use retrofit kit 003233 (50Hz) to upgrade LT300 prior to Rev. A8.00 ([See Section 3.8](#)).

<sup>5</sup> Pulley Guard Weldment 033165 obsolete. Use new guard weldment 036678 to service all drive systems ([See Section 3.8](#)).

### 3.10 Blade Motor Drive Assembly

LT300 Rev. A1.00 - A6.01

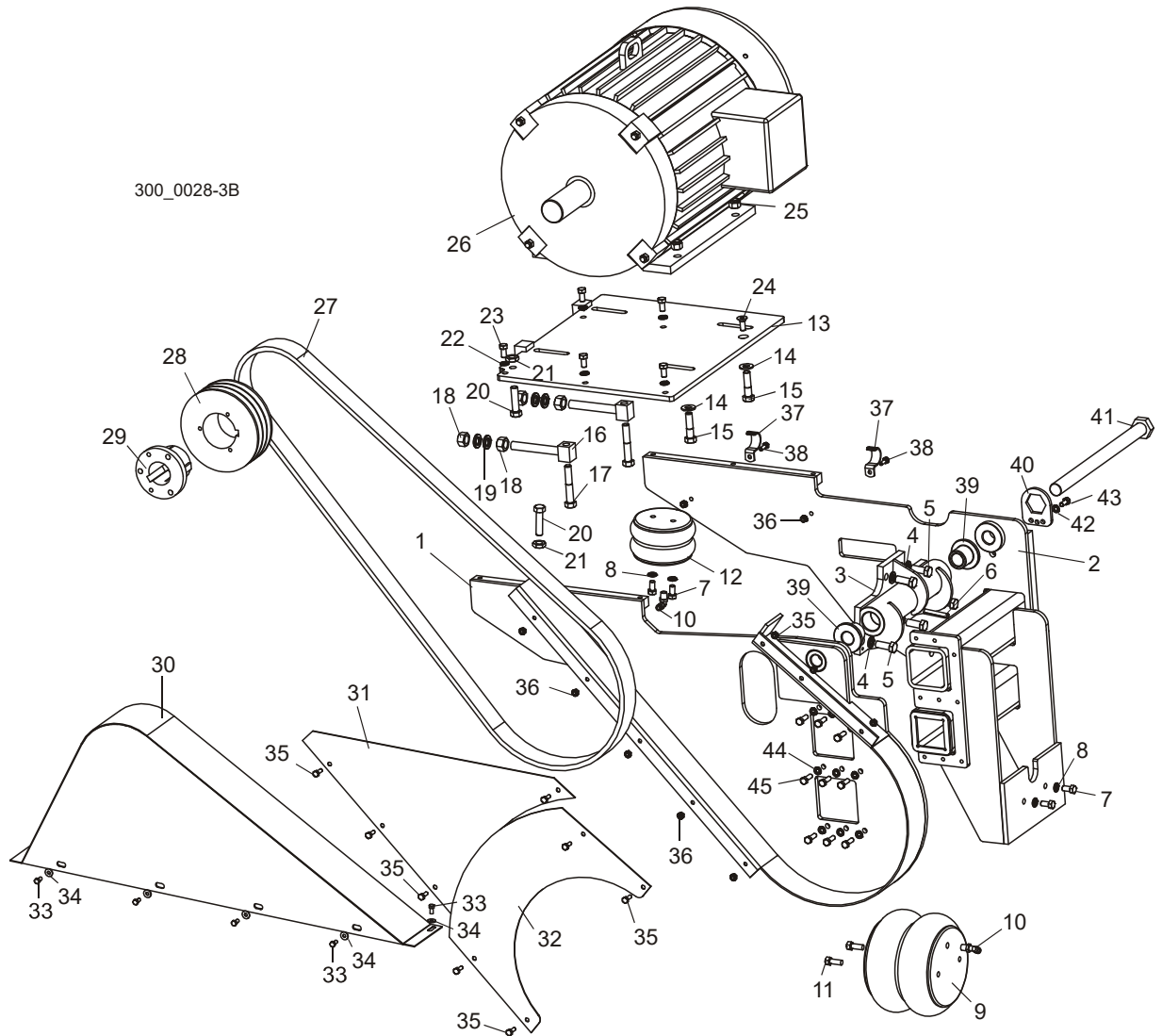

REF	DESCRIPTION (◆ Indicates Parts Available In Assemblies Only)	PART #	QTY.
1	BRACKET WELDMENT, FRONT MOTOR MOUNT	033211	1
2	BRACKET WELDMENT, REAR MOTOR MOUNT	033216	1
3	PIVOT WELDMENT, MOTOR MOUNT	033206	1
4	WASHER, 1/2" SPLIT LOCK	F05011-9	5
5	BOLT, 1/2-13 X 1 1/4" HEX HEAD GRADE 5	F05008-37	5
6	PIN, 3/8" X 2" ROLL	F05012-42	2
7	BOLT, 3/8-16 X 3/4" HEX HEAD GRADE 2	F05007-27	4
8	WASHER, 3/8" SPLIT LOCK	F050011-4	4



## Blade Wheels & Tensioner

*Blade Motor Drive Assembly*

3

9	BAG, TENSIONER AIR	033229	1	
10	FITTING, 1/4" NPT X 1/4" AIR 90 ELBOW	P21519	2	
11	BOLT, 3/8-16 X 1" HEX HEAD GRADE 5	F05007-87 <sup>1</sup>	2	
12	BAG, MOTOR LIFT AIR	033231	1	
13	PLATE WELDMENT, MOTOR MOUNT	042461 <sup>2</sup>	1	
14	WASHER, 1/2" SAE FLAT	F05011-2	2	
15	BOLT, 1/2-13 X 2" HEX HEAD	F05008-76	2	
16	ROD WELDMENT, BELT TENSIONER	016893 <sup>2</sup>	2	
17	BOLT, 1/2-13 X 3" HEX HEAD GRADE 5	F05008-23	2	
18	NUT, 5/8-11 HEX	F05010-5	4	
19	WASHER, 5/8" SPLIT LOCK	F05011-27	4	
20	BOLT, 1/2-13 X 2" HEX HEAD FULL THREAD	F05008-8	2	
21	NUT, 1/2-13 HEX JAM	F05010-31	3	
22	WASHER, 3/8" SPLIT LOCK	F05011-4	5	
23	BOLT, 3/8-16 X 3/4" HEX HEAD GRADE 2	F05007-27	5	
24	BOLT, 3/8-16 X 1" FLAT SOCKET HEAD	F05007-64 <sup>2</sup>	1	
25	NUT, 1/2-13 HEX NYLON LOCK	F05010-8	4	
26	MOTOR, 30HP 1800RPM	042301	1	
27	BELT, 3/5VX950 DRIVE	045190 <sup>3</sup>	1	
	BELT, 3/5VXFL975 (50HZ)	036109 <sup>4</sup>	1	
28	PULLEY, 3/5V MOTOR DRIVE	045189 <sup>5</sup>	1	◆
	PULLEY, 3R5V80 MOTOR DRIVE (50HZ)	036110 <sup>6</sup>	1	◆
29	BUSHING, Q1 X 1 7/8"	042353	1	
	BUSHING, R1 X 1 7/8" (50HZ)	036111 <sup>2</sup>	1	
30	COVER WELDMENT, BELT GUARD	033165 <sup>7</sup>	1	
31	COVER, UPPER BELT	045050	1	
32	COVER, LOWER BELT	045034	1	
33	BOLT, 1/4-20 X 1/2" HEX HEAD	F05005-15	5	
34	WASHER, 1/4" SAE FLAT	F05011-11	5	
35	BOLT, 1/4-20 X 3/4" HEX HEAD	F05005-129	8	
36	NUT, 1/4-20 SELF-LOCKING HEX	F05010-9	10	
37	CLAMP, 1" EMT	P05436	2	
38	BOLT, 1/4-20 X 3/4" HEX HEAD FULL THREAD	F05005-1	2	
39	BEARING, MOTOR PIVOT	033210	2	
40	PLATE, PIVOT BOLT LOCK	033230	1	
41	BOLT WELDMENT, MOTOR PIVOT	033225	1	
42	WASHER, 5/16" SPLIT LOCK	F05011-13	1	
43	BOLT, 5/16-18 X 3/4" HEX HEAD	F05006-5	1	
44	WASHER, 5/16" SPLIT LOCK	F05011-13	9	
45	BOLT, 5/16-18 X 1" HEX HEAD GRADE 5	F05006-48	9	

<sup>1</sup> 3/8-16 x 1" Hex Head Grade 5 Bolts F05007-87 replace 3/8-16 x 1 1/4" Oval Point Socket Set Screws F05007-18 to better secure air bag during blade tensioning (LT300 Rev. A2.00+). Bolt heads engage slotted keyways in bracket to hold air bag in place.

# 3

## Blade Wheels & Tensioner

### *Blade Motor Drive Assembly*

---

- <sup>2</sup> Motor Mount Plate Weldment 042421 revised to accept Flat Head Bolt F05007-64 to eliminate interference with drive belt adjustment and new Tension Rod Weldments 016893 to improve durability of belt tensioning system (LT300 Rev. A2.00+). Mount Weldment revised and Tensioning/Mounting Hardware replaced Rev. A7.00 to improve belt tension adjustment ([See Section 3.9](#)).
- <sup>3</sup> Drive may be retrofitted with Eagle PD system to improve power transmission. Use retrofit kit 036679 (60Hz) to upgrade LT300 prior to Rev. A8.00 ([See Section 3.8](#)).
- <sup>4</sup> Alternate drive belt, motor pulley and bushing for 50Hz operation. All three parts included in kit 036108. Drive may be retrofitted with Eagle PD system to improve power transmission. Use retrofit kit 003233 (50Hz) to upgrade LT300 prior to Rev. A8.00 ([See Section 3.8](#)).
- <sup>5</sup> Motor Pulley 045189 no longer available. Upgrade drive system to Eagle PD system to improve power transmission. Use retrofit kit 036679 (60Hz) to upgrade LT300 prior to Rev. A8.00 ([See Section 3.8](#)).
- <sup>6</sup> Motor Pulley 036110 no longer available. Upgrade drive system to Eagle PD system to improve power transmission. Use retrofit kit 003233 (50Hz) to upgrade LT300 prior to Rev. A8.00 ([See Section 3.8](#)).
- <sup>7</sup> Pulley Guard Weldment 033165 obsolete. Use new guard weldment 036678 to service all drive systems ([See Section 3.8](#)).

## SECTION 4 SAW HEAD

### 4.1 Board Return

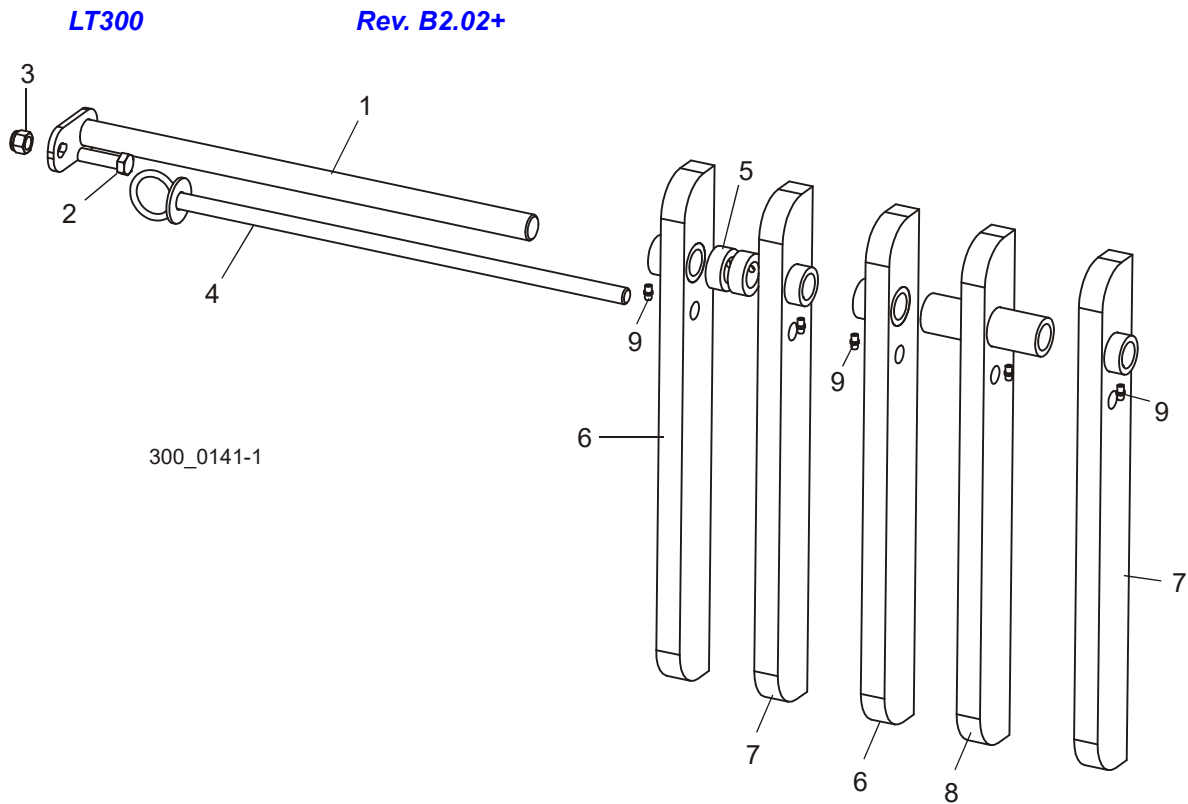

REF	DESCRIPTION (◆ Indicates Parts Available In Assemblies Only)	PART #	QTY.
1	PIN WELDMENT, BOARD RETURN PIVOT	042167	1
2	BOLT, 1/2-13 X 1 3/4" HEX HEAD GRADE 5	F05008-88	1
3	NUT, 1/2-13 HEX NYLON LOCK	F05010-8	1
4	PIN WELDMENT, SUPPORT	042168 <sup>1</sup>	1
5	COLLAR, 1" LOCK	038090	2
6	ARM WELDMENT, LEFT BOARD RETURN	003659	2
7	ARM WELDMENT, RIGHT BOARD RETURN	003660	2
8	ARM WELDMENT, MIDDLE BOARD RETURN	003661	1
9	FITTING, 1/4-28 GREASE	P05060	5

<sup>1</sup> Pin Weldment 042168 modified 2/10. Diameter decreased to provide easier assembly.

## 4.2 Board Return

LT300

Rev. A7.00 - B2.01

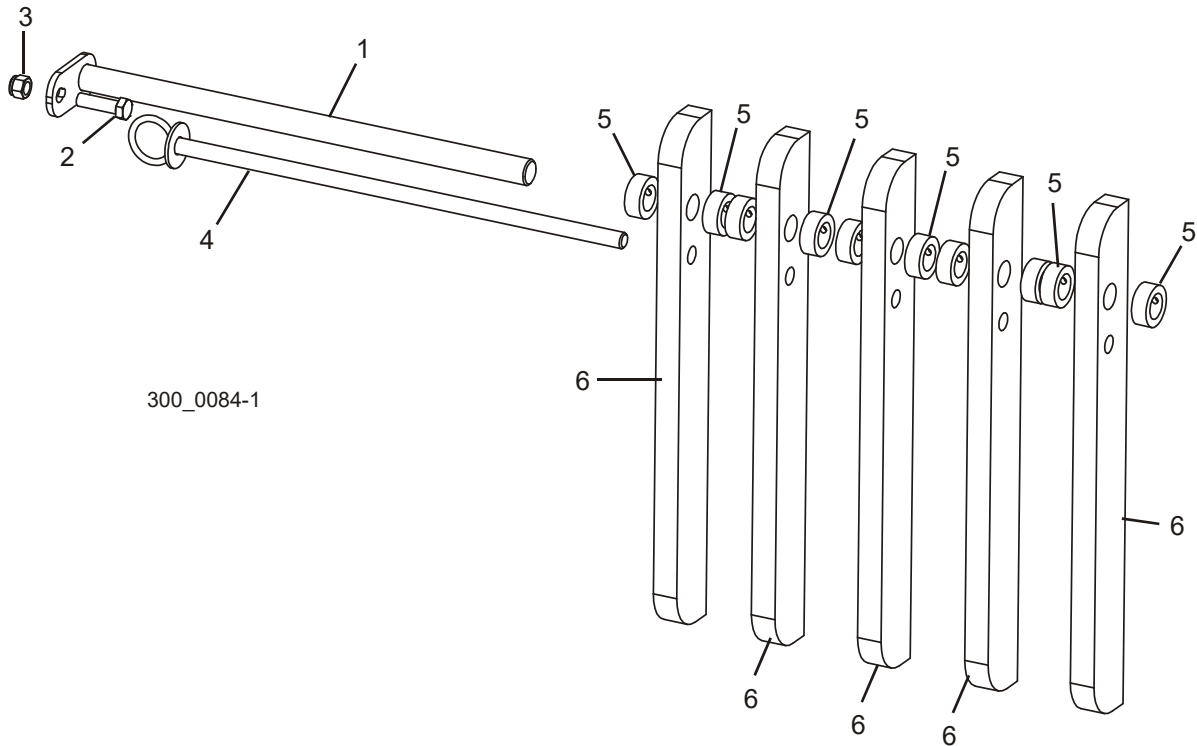

REF	DESCRIPTION (◆ Indicates Parts Available In Assemblies Only)	PART #	QTY.
1	PIN WELDMENT, BOARD RETURN PIVOT	042167 <sup>1</sup>	1
2	BOLT, 1/2-13 X 1 3/4" HEX HEAD GRADE 5	F05008-88 <sup>1</sup>	1
3	NUT, 1/2-13 HEX NYLON LOCK	F05010-8 <sup>1</sup>	1
4	PIN WELDMENT, SUPPORT	042168 <sup>2</sup>	1
5	COLLAR, 1" LOCK	038090	10
6	ARM, BOARD RETURN	036464 <sup>1</sup>	5

<sup>1</sup> Pivot Pin Weldment 042167 modified to accept new Board Return Arms, Bolt and Nut to reduce bounce (Rev. A7.00). [See Section 4.3](#) for previous revisions. Board Return Arms 036464 replaced with weldments Rev. B2.02 to improve durability ([See Section 4.1](#)).

<sup>2</sup> Pin Weldment 042168 modified 2/10. Diameter decreased to provide easier assembly.

### 4.3 Board Return

LT300

Rev. A1.00 - A6.01

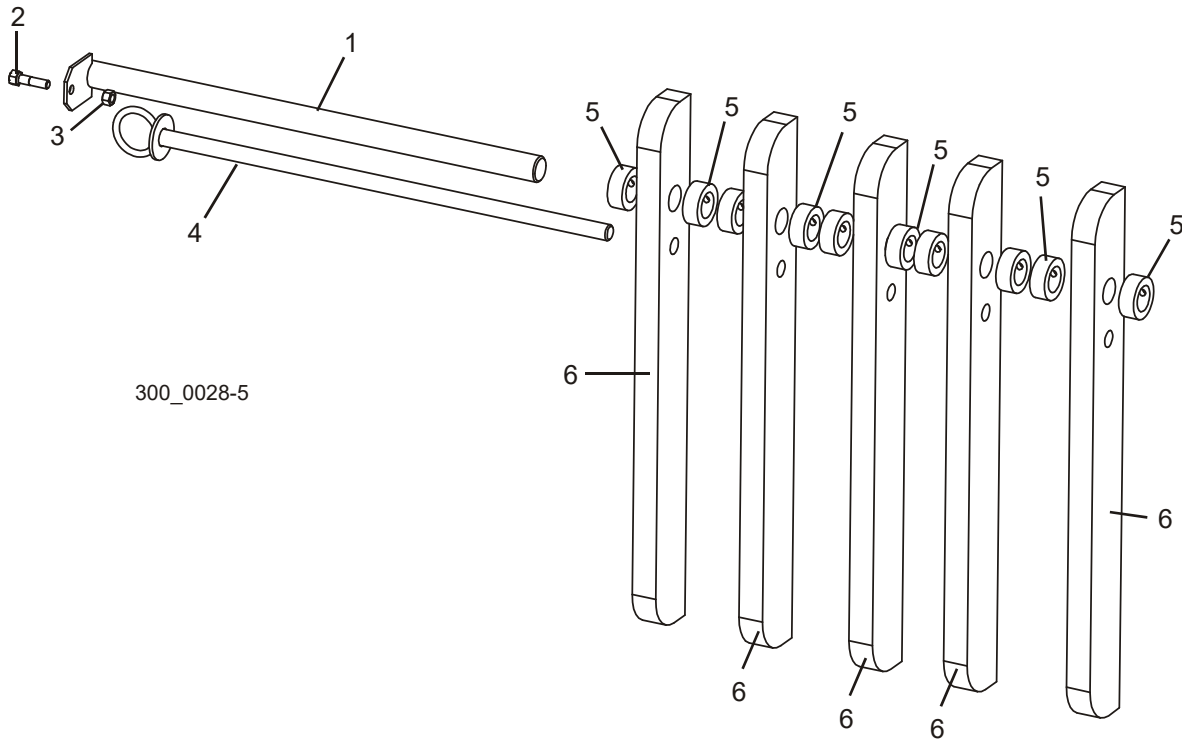

REF	DESCRIPTION (◆ Indicates Parts Available In Assemblies Only)	PART #	QTY.
1	PIN WELDMENT, BOARD RETURN PIVOT	042167	1
2	BOLT, 5/16-18 X 1 1/4" HEX HEAD	F05009-62	1
3	NUT, 5/16-18 HEX LOCK	F05010-6	1
4	PIN WELDMENT, SUPPORT	042168 <sup>1</sup>	1
5	COLLAR, 1" LOCK	038090	10
6	ARM, BOARD RETURN	042166	5

<sup>1</sup> Pin Weldment 042168 modified 2/10. Diameter decreased to provide easier assembly.

# 4 Saw Head

## Board Return Guide

### 4.4 Board Return Guide

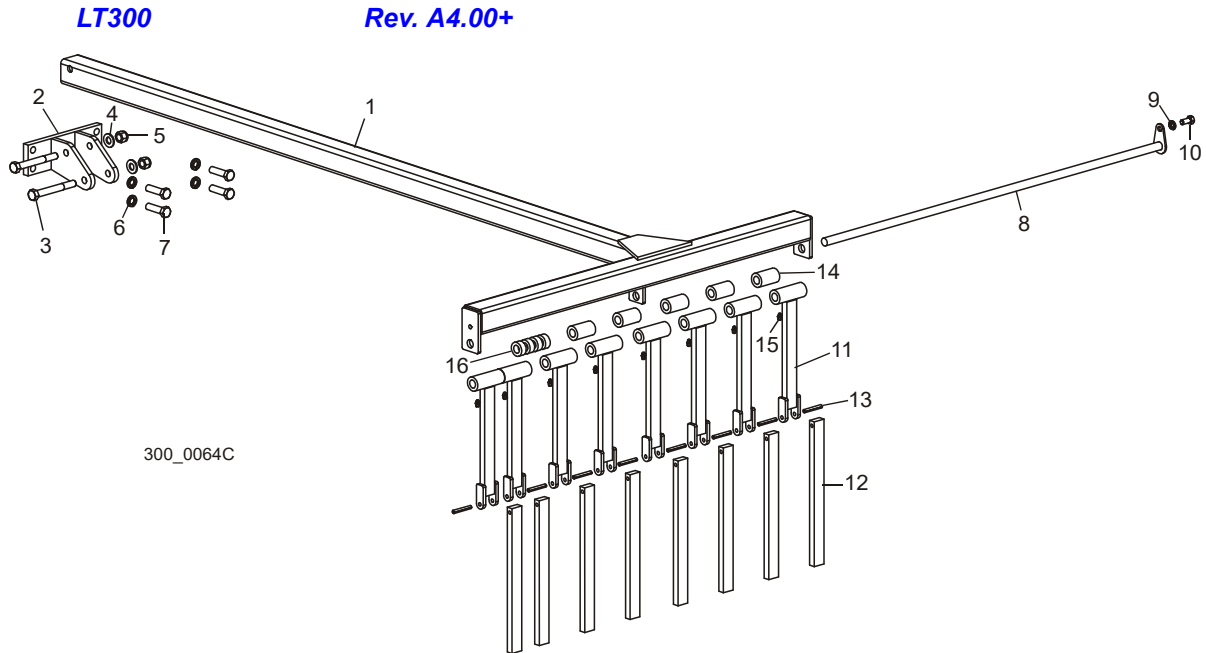

REF	DESCRIPTION (◆ Indicates Parts Available In Assemblies Only)	PART #	QTY.
	<b>GUIDE ASSEMBLY, BOARD RETURN</b>	017808 <sup>1</sup>	1
1	Guide Weldment, Board Return	017809 <sup>1</sup>	1
2	Bracket Weldment, Board Return Guide Mount	017811	1
3	Bolt, 1/2-13 x 4" Hex Head	F05008-26	2
4	Washer, 1/2" SAE Flat	F05011-2	2
5	Nut, 1/2-13 Hex Nylon Lock	F05010-8	2
6	Washer, 1/2" Split Lock	F05011-9	4
7	Bolt, 1/2-13 1 3/4" Hex Head Grade 5	F05008-88	4
8	Rod Weldment, Board Return Guide	034408	1
9	Washer, 3/8" Split Lock	F05011-4	1
10	Bolt, 3/8-16 x 3/4" Hex Head Grade 5	F05007-118	1
11	Bar Weldment, Board Guide Upper	017823	8
12	Bar, Board Guide Lower	017822	8
13	Pin, 1/4" x 1 3/4" Roll	F05012-53	8
14	Tube, Board Guide Spacer	017820 <sup>2</sup>	5
15	Fitting, 3/16" x 3/16" Straight Grease	P04107	8
16	Tube, Board Guide Spacer (.46")	003687 <sup>2</sup>	4

<sup>1</sup> Guide Weldment 017809 modified and Bar/Spacers rearranged to improve dragback of square cants during return (Rev. A7.02).  
<sup>2</sup> One 017820 spacer replaced by four shorter spacers 003687 to allow proper position of guide fingers to improve functionality (Rev. B2.02). Use any combination of short spacers to position last guide finger 1/2" from clamp stop.

## 4.5 Board Return Guide

LT300

Rev. A1.00 - A3.00

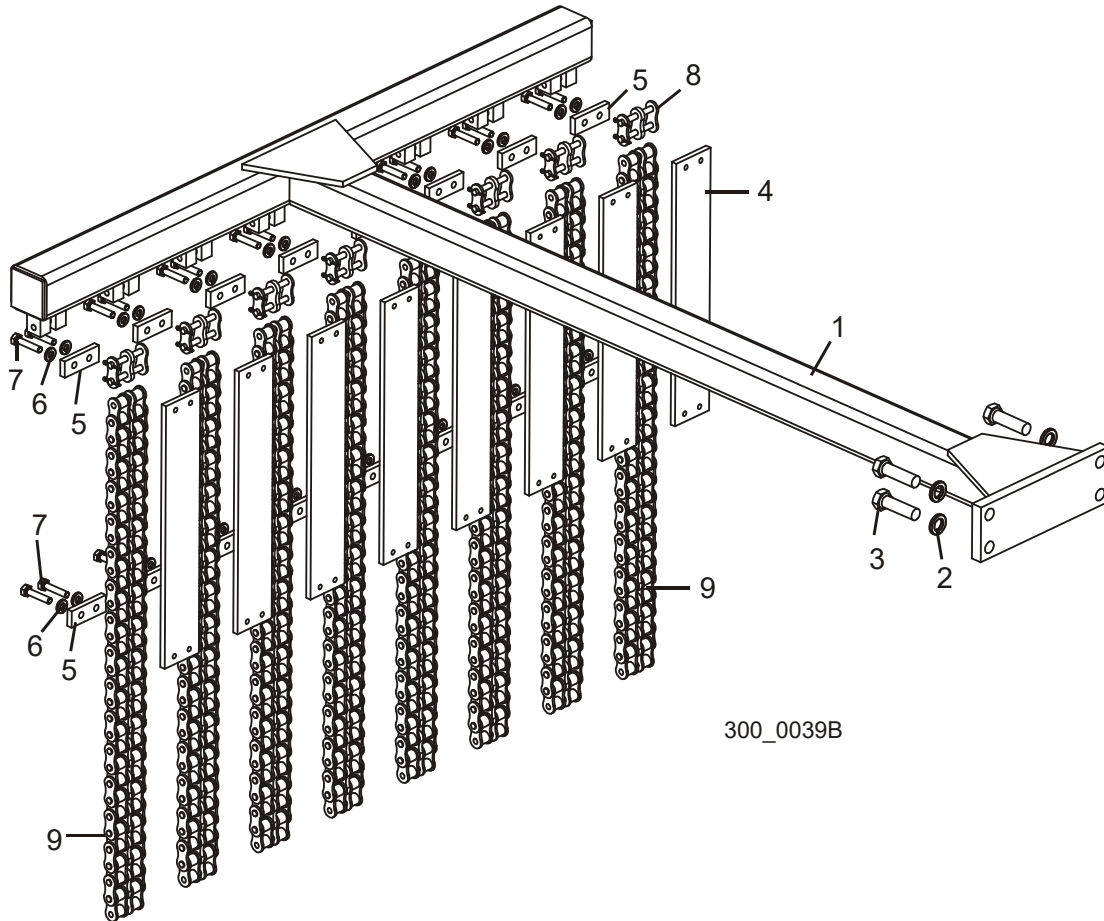

REF	DESCRIPTION (◆ Indicates Parts Available In Assemblies Only)	PART #	QTY.
	<b>GUIDE ASSEMBLY, BOARD RETURN</b>	042423	1
1	Guide Weldment, Board Return	042224	1
2	Washer, 1/2" Split Lock	F05011-9	4
3	Bolt, 1/2-13 x 1 3/4" Hex Head Grade 5	F05008-88	4
	Stiffener Retrofit, Board Return Guide Chain	016897 <sup>1</sup>	1
4	Plate, Board Return Guide Chain Stiffener	042741	8
5	Plate, Board Return Guide Chain Clamp	042742	16
6	Washer, 1/4" Split Lock	F05011-14	32
7	Bolt, 1/4-20 x 1 1/4 Hex Head Grade 5	F05005-116	32
8	Link, 60-2 Chain Connector	023873-ML	8
9	Chain, Board Return Guide	042424	8

<sup>1</sup> Chain Stiffener Retrofit 016897 available for LT300 prior to Rev. A2.00. Plates added to improve chain durability.

# 4 Saw Head Covers & Sawdust Chute

## 4.6 Covers & Sawdust Chute

LT300

Rev. B2.00+

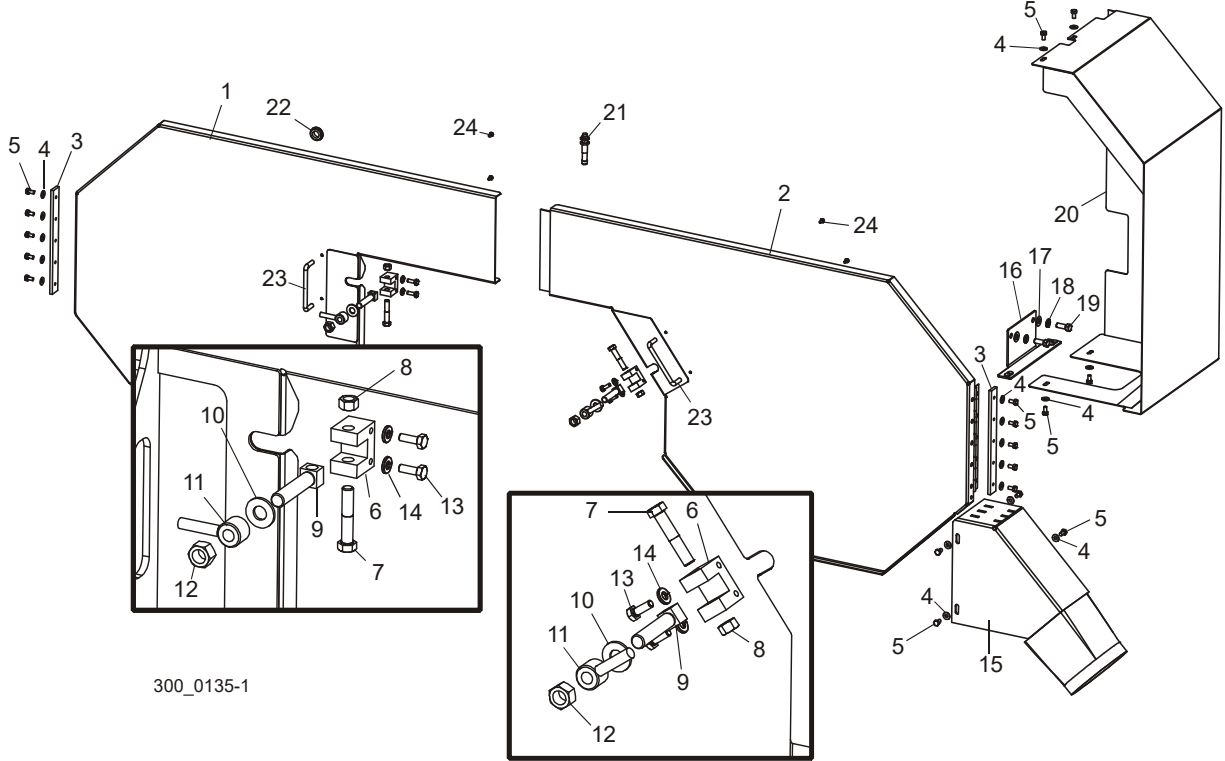

REF	DESCRIPTION (◆ Indicates Parts Available In Assemblies Only)	PART #	QTY.
1	COVER WELDMENT, IDLE SIDE BLADE HOUSING	038982	1
2	COVER WELDMENT, DRIVE SIDE BLADE HOUSING	038981	1
3	PLATE, COVER MOUNT	042435	2
4	WASHER, 1/4" SAE FLAT	F05011-11	18
5	BOLT, 1/4-20 X 1/2" HEX HEAD	F05005-15	18
	LATCH ASSEMBLY, BLADE HOUSING COVER	042440	2
6	Block, Cover Latch	042439	1
7	Bolt, 3/8-16 x 2" Hex Head	F05007-72	1
8	Nut, 3/8-16 Hex Lock	F05010-25	1
9	Bolt, Cover Latch	042438	1
10	Washer, 1/2" SAE Flat	F05011-2	1
11	Handle Weldment, Cover Latch	021145	1
12	Nut, 1/2-13 Hex Lock	F05010-3	1
13	BOLT, 1/4-20 X 3/4" HEX HEAD FULL THREAD	F05005-1	4
14	WASHER, 1/4" SPLIT LOCK	F05011-14	4
15	CHUTE WELDMENT, SAWDUST	045005	1
16	BRACKET WELDMENT, SIDE GUARD MOUNT	036847	1



17	WASHER, 3/8" SAE FLAT	F05011-3	2	
18	WASHER, 3/8" SPLIT LOCK	F05011-4	2	
19	BOLT, 3/8-16 X 1" HEX HEAD GRADE 5	F05007-87	2	
20	GUARD WELDMENT, SIDE	036845	1	
21	SENSOR, 12MM EXTENDED PROXIMITY	025041	1	
22	GROMMET, 5/8" ID RUBBER	P11764	1	
23	HANDLE, 4" DOOR	P08065	2	
24	SCREW, #8-32 X 3/8" SELF-TAPPING	F05015-8	4	

# 4 Saw Head

## Covers & Sawdust Chute

### 4.7 Covers & Sawdust Chute

LT300

Rev. A9.00 - B1.01

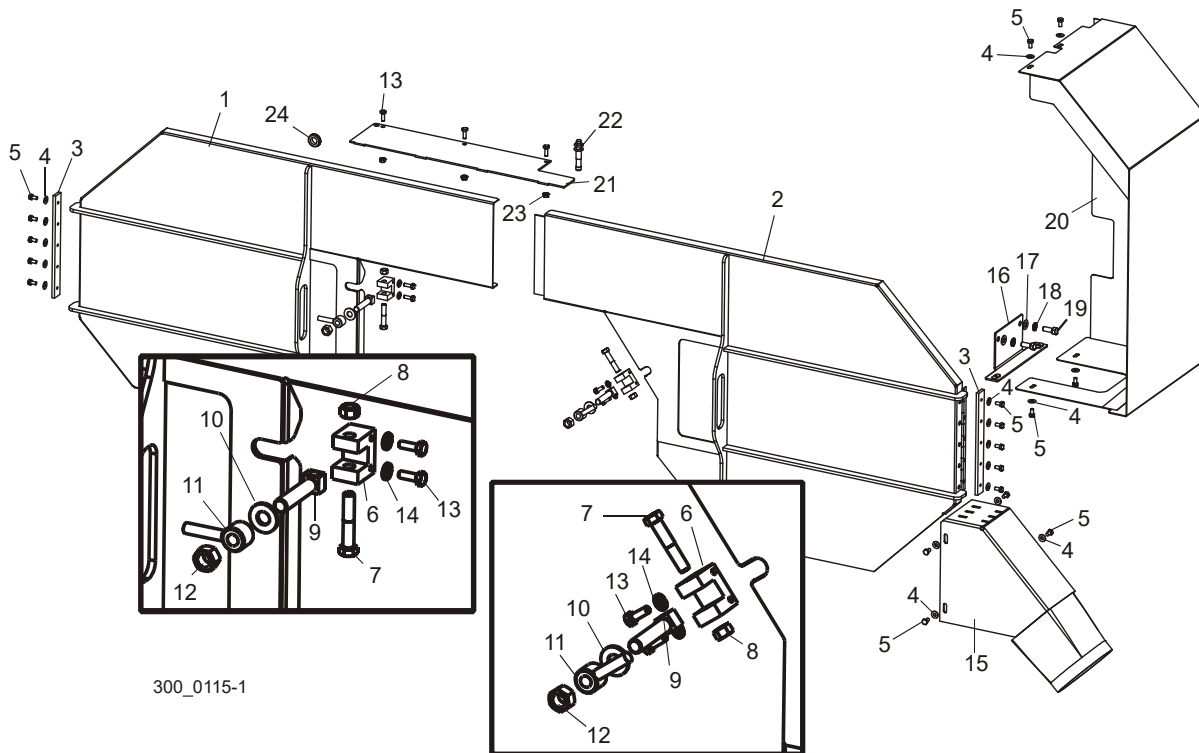

REF	DESCRIPTION (◆ Indicates Parts Available In Assemblies Only)	PART #	QTY.
1	COVER WELDMENT, IDLE SIDE BLADE HOUSING	042341	1
2	COVER WELDMENT, DRIVE SIDE BLADE HOUSING	042340	1
3	PLATE, COVER MOUNT	042435	2
4	WASHER, 1/4" SAE FLAT	F05011-11	18
5	BOLT, 1/4-20 X 1/2" HEX HEAD	F05005-15	18
	LATCH ASSEMBLY, BLADE HOUSING COVER	042440	2
6	Block, Cover Latch	042439	1
7	Bolt, 3/8-16 x 2" Hex Head	F05007-72	1
8	Nut, 3/8-16 Hex Lock	F05010-25	1
9	Bolt, Cover Latch	042438	1
10	Washer, 1/2" SAE Flat	F05011-2	1
11	Handle Weldment, Cover Latch	021145	1
12	Nut, 1/2-13 Hex Lock	F05010-3	1
13	BOLT, 1/4-20 X 3/4" HEX HEAD FULL THREAD	F05005-1	7
14	WASHER, 1/4" SPLIT LOCK	F05011-14	4
15	CHUTE WELDMENT, SAWDUST	045005	1
16	BRACKET WELDMENT, SIDE GUARD MOUNT	036847 <sup>1</sup>	1

17	WASHER, 3/8" SAE FLAT	F05011-3	2	
18	WASHER, 3/8" SPLIT LOCK	F05011-4	2	
19	BOLT, 3/8-16 X 1" HEX HEAD GRADE 5	F05007-87	2	
20	GUARD WELDMENT, SIDE	036845 <sup>1</sup>	1	
21	PLATE, BOTTOM SAW HEAD WIREWAY	042252	1	
22	SENSOR, 12MM EXTENDED PROXIMITY	025041	1	
23	NUT, 1/4-20 HEX SELF-LOCKING	F05010-9	3	
24	GROMMET, 5/8" ID RUBBER	P11764	1	

<sup>1</sup> Side Guard Mount 036847 and Side Guard 036845 replace old guards Rev. A9.00 to accommodate dampener assembly for machines equipped with belted blade wheels ([See Section 3.5](#)). Kit 036841 includes dampener assembly, side guard and guard mount.

# 4 Saw Head

## Covers & Sawdust Chute

### 4.8 Covers & Sawdust Chute

LT300

Rev. A7.00 - A8.00

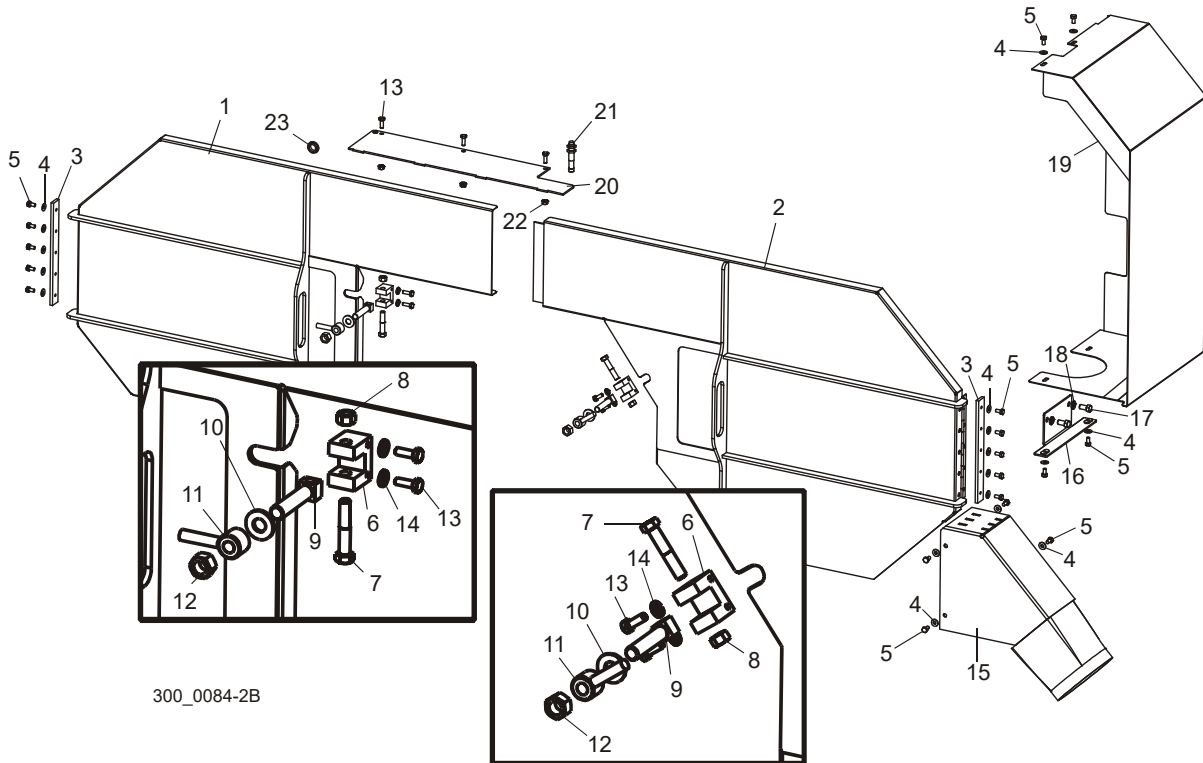

300\_0084-2B

REF	DESCRIPTION (◆ Indicates Parts Available In Assemblies Only)	PART #	QTY.
1	COVER WELDMENT, IDLE SIDE BLADE HOUSING	042341	1
2	COVER WELDMENT, DRIVE SIDE BLADE HOUSING	042340	1
3	PLATE, COVER MOUNT	042435	2
4	WASHER, 1/4" SAE FLAT	F05011-11	18
5	BOLT, 1/4-20 X 1/2" HEX HEAD	F05005-15	18
	LATCH ASSEMBLY, BLADE HOUSING COVER	042440	2
6	Block, Cover Latch	042439	1
7	Bolt, 3/8-16 x 2" Hex Head	F05007-72	1
8	Nut, 3/8-16 Hex Lock	F05010-25	1
9	Bolt, Cover Latch	042438	1
10	Washer, 1/2" SAE Flat	F05011-2	1
11	Handle Weldment, Cover Latch	021145	1
12	Nut, 1/2-13 Hex Lock	F05010-3	1
13	BOLT, 1/4-20 X 3/4" HEX HEAD FULL THREAD	F05005-1	7
14	WASHER, 1/4" SPLIT LOCK	F05011-14	4
15	CHUTE WELDMENT, SAWDUST	045005	1
16	BRACKET WELDMENT, SIDE GUARD MOUNT	042442	1

17	<b>BOLT, 3/8-16 X 3/4" HEX HEAD GRADE 2</b>	F05007-27	2	
18	<b>WASHER, 3/8" SPLIT LOCK</b>	F05011-4	2	
19	<b>GUARD WELDMENT, SIDE</b>	033184	1	
20	<b>PLATE, BOTTOM SAW HEAD WIREWAY</b>	042252	1	
21	<b>SENSOR, 12MM EXTENDED PROXIMITY</b>	025041	1	
22	<b>NUT, 1/4-20 HEX SELF-LOCKING</b>	F05010-9	3	
23	<b>GROMMET, 5/8" ID RUBBER</b>	P11764	1	

# 4 Saw Head

## Covers & Sawdust Chute

### 4.9 Covers & Sawdust Chute

LT300

Rev. A1.00 - A6.01

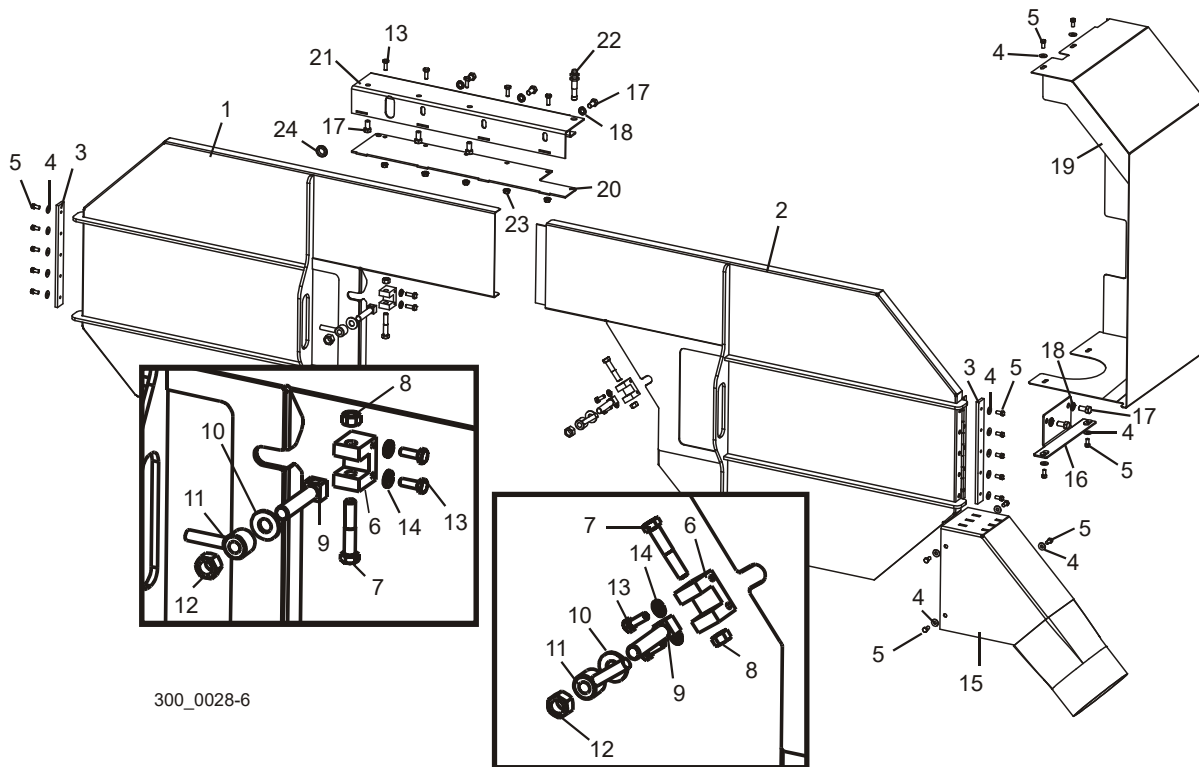

300\_0028-6

REF	DESCRIPTION (◆ Indicates Parts Available In Assemblies Only)	PART #	QTY.
1	COVER WELDMENT, IDLE SIDE BLADE HOUSING	042341 <sup>1</sup>	1
2	COVER WELDMENT, DRIVE SIDE BLADE HOUSING	042340 <sup>1</sup>	1
3	PLATE, COVER MOUNT	042435	2
4	WASHER, 1/4" SAE FLAT	F05011-11	18
5	BOLT, 1/4-20 X 1/2" HEX HEAD	F05005-15	18
	LATCH ASSEMBLY, BLADE HOUSING COVER	042440	2
6	Block, Cover Latch	042439	1
7	Bolt, 3/8-16 x 2" Hex Head	F05007-72	1
8	Nut, 3/8-16 Hex Lock	F05010-25	1
9	Bolt, Cover Latch	042438	1
10	Washer, 1/2" SAE Flat	F05011-2	1
11	Handle Weldment, Cover Latch	021145	1
12	Nut, 1/2-13 Hex Lock	F05010-3	1
13	BOLT, 1/4-20 X 3/4" HEX HEAD FULL THREAD	F05005-1	9
14	WASHER, 1/4" SPLIT LOCK	F05011-14	4
15	CHUTE WELDMENT, SAWDUST	045005	1
16	BRACKET WELDMENT, SIDE GUARD MOUNT	042442	1

17	<b>BOLT, 3/8-16 X 3/4" HEX HEAD GRADE 2</b>	F05007-27	8	
18	<b>WASHER, 3/8" SPLIT LOCK</b>	F05011-4	5	
19	<b>GUARD WELDMENT, SIDE</b>	033184	1	
20	<b>PLATE, BOTTOM SAW HEAD WIREWAY</b>	042252	1	
21	<b>CHANNEL, TOP SAW HEAD WIREWAY</b>	042251 <sup>2</sup>	1	
22	<b>SENSOR, 12MM EXTENDED PROXIMITY</b>	025041	1	
23	<b>NUT, 1/4-20 HEX SELF-LOCKING</b>	F05010-9	5	
24	<b>GROMMET, 5/8" ID RUBBER</b>	P11764	1	

<sup>1</sup> Stiffener plates added to blade housing cover weldments to eliminate distortion caused by door latches (LT300 Rev. A2.00). Use kit 042799 to retrofit earlier revisions.

<sup>2</sup> Channel welded to C-frame Rev. A7.00 to reduce assembly and fasteners ([See Section 4.8](#)).

# 4 Saw Head

## Blow-Off Assembly

### 4.10 Blow-Off Assembly

LT300

Rev. A2.00+

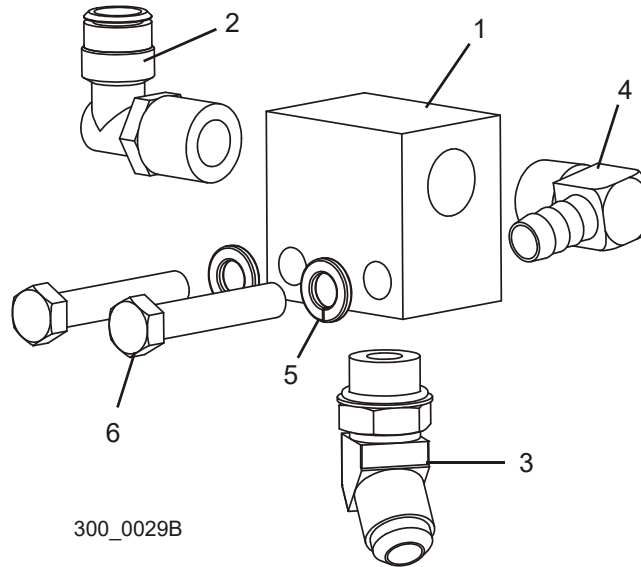

REF	DESCRIPTION (◆ Indicates Parts Available In Assemblies Only)	PART #	QTY.
	<b>BLOCK ASSEMBLY, BLOW-OFF</b>	016882	1
1	Block, Blow-Off	016879	1
2	Fitting, 1/2" NPT x 1/2" Tube 90° Swivel Elbow	016880	1
3	Fitting, #8 JIC x #8 SAE 45° Elbow	041161	1
4	Fitting, 1/2" NPT x 1/2" Hose Barb 90° Elbow	015997 <sup>1</sup>	1
5	Washer, 3/8" Split Lock	F05011-4	2
6	Bolt, 3/8-16 x 2" Hex Head Full Thread	F05007-16	2
	<b>TUBING, 1/2" CHAINFLEX AIR LINE</b>	R01869-5	54 Ft. <sup>2</sup>
	<b>TUBING, 1/2" CHAINFLEX AIR LINE</b>	R01869-5	4 Ft.

<sup>1</sup> Elbow Fitting 015997 replaces one Swivel Elbow Fitting 016880 to improve durability (Rev. A7.00).

<sup>2</sup> Additional 6 foot of hose supplied for LT300-BX6. Additional 10 foot hose supplied for LT300-BX10WM3000-BX10.



## 4.11 Blow-Off Assembly

Rev. A1.00 - A1.01

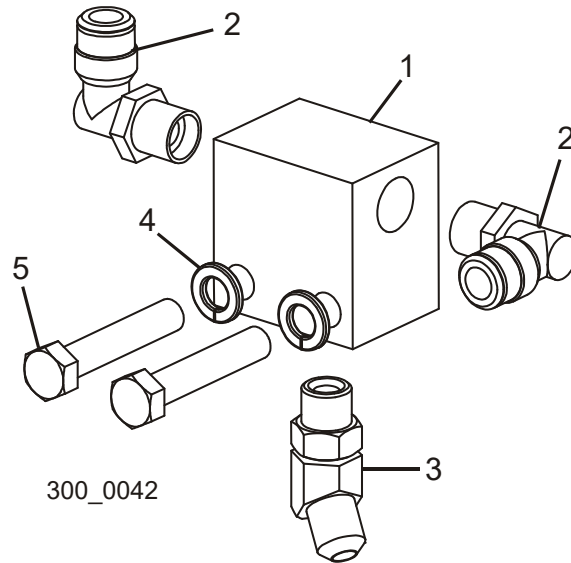

REF	DESCRIPTION (◆ Indicates Parts Available In Assemblies Only)	PART #	QTY.
	<b>BLOCK ASSEMBLY, BLOW-OFF</b>	042658 <sup>1</sup>	1
1	Block, Blow-Off	042656	1
2	Fitting, 3/8" NPT x 3/8" Tube 90° Elbow	P21526	2
3	Fitting, #6 SAE 45° Elbow	015489	1
4	Washer, 3/8" Split Lock	F05011-4	2
5	Bolt, 3/8-16 x 2" Hex Head Full Thread	F05007-16	2
	<b>TUBING, 3/8" AIR LINE</b>	005453	54 Ft.
	<b>TUBING, 3/8" AIR LINE</b>	005453	4 Ft.

<sup>1</sup> Blow-Off Assembly 042658 replaced by assembly 016882 with 1/2" plumbing on LT300 Rev. A2.00 ([See Section 4.10](#)).

# 4 Saw Head

## Laser Assembly

### 4.12 Laser Assembly

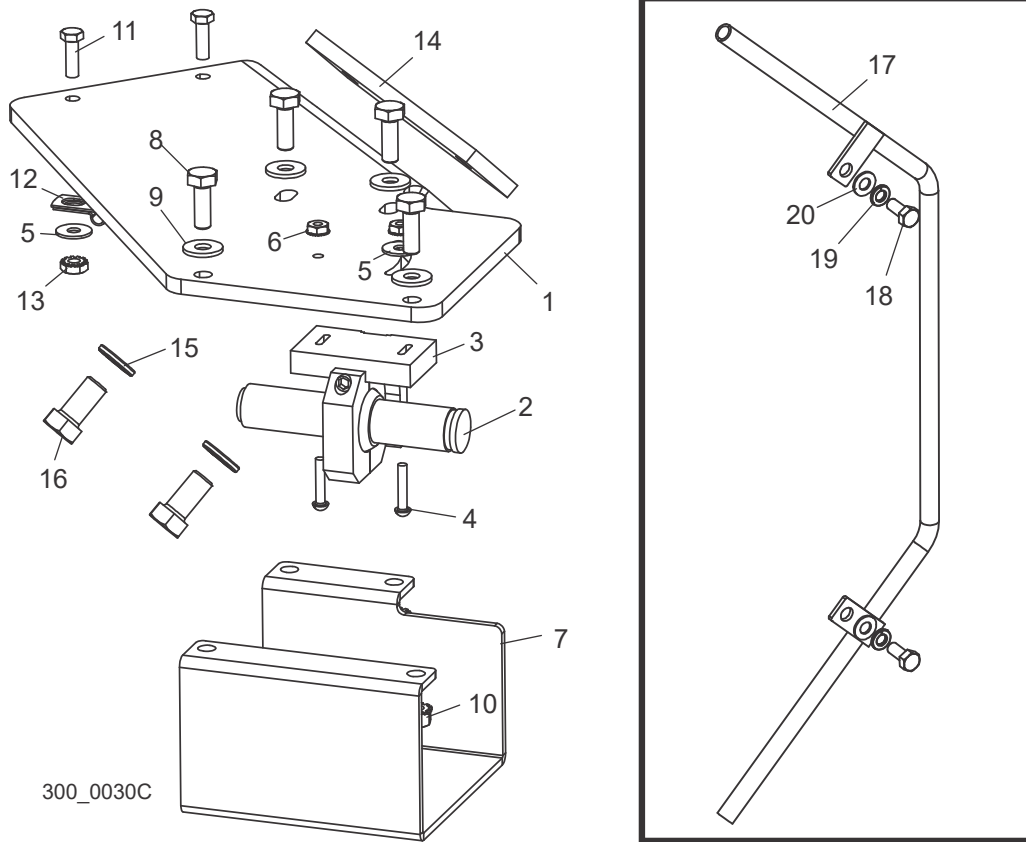

REF	DESCRIPTION (◆ Indicates Parts Available In Assemblies Only)	PART #	QTY.
	<b>LASER ASSEMBLY, LT300</b>	042169	1
1	Plate, Laser Mount	042744 <sup>1</sup>	1
2	Laser, 15mW 635nM 60° Line w/Mounting Bracket	025125	1
3	Bracket, Laser Mount	045250	1
4	Screw, #6-32 x 3/4" Slotted Round Head	F05004-21	2
5	Washer, #10 SAE Flat	F05011-18	3
6	Nut, #6 Hex Self-Locking	F05010-59	2
7	Cover, Laser Guard	042743 <sup>1</sup>	1
8	Bolt, 1/4-20 x 3/4" Hex Head Full Thread	F05005-1 <sup>1</sup>	4
9	Washer, 1/4" SAE Flat	F05011-11 <sup>1</sup>	4
10	Nut, 1/4-20 Hex Self-Locking	F05010-9 <sup>1</sup>	4
11	Bolt, #10-24 x 5/8" Hex Head	F05004-18	2
12	Clamp, .187 Cushioned Metal Cable	025196	2
13	Nut, #10-24 Hex Self-Locking	F05010-14	2
14	Plate, Laser Mount Nut	042452	1

<b>15</b>	Washer, 3/8" Split Lock	F05011-4	2	
<b>16</b>	Bolt, 3/8-16 x 3/4" Hex Head Grade 2	F05007-27	2	
<b>17</b>	<b>CONDUIT WELDMENT, LASER</b>	074784	1	
<b>18</b>	<b>BOLT, 5/16-18 X 3/4" HEX HEAD GRADE 5</b>	F05006-102	2	
<b>19</b>	<b>WASHER, 5/16" SPLIT LOCK</b>	F05011-13	2	
<b>20</b>	<b>WASHER, 5/16" SAE FLAT</b>	F05011-17	2	

<sup>1</sup> Laser Mount Plate 042744 replaces 042170 originally supplied prior to LT300 Rev. A2.00 to accommodate guard. Laser Guard Cover 042743 and mounting bolts, washers and nuts added to protect laser from damage.

### 4.13 Decals

### 4.14 Decals



REF	DESCRIPTION (◆ Indicates Parts Available In Assemblies Only)	PART #	QTY.
1	DECAL, RESHARP INFO	P12879	1
2	DECAL, TRANSDUCER ADJUSTMENT CAUTION	042674	1
3	DECAL, LT300 DOOR LOGO	052270 <sup>1</sup>	1
4	DECAL, SAWDUST CHUTE WARNING	P11754	1
5	DECAL, EYE/EAR PROTECTION WARNING	P12879	1
6	DECAL, MOVING PARTS DANGER	033254	2
7	DECAL, WARNING STRIPE	016834	7
8	DECAL, BLADE INSPECTION WARNING	034801 <sup>2</sup>	1
9	DECAL, LT300 BLADE GUIDE INFO (LARGE)	034803 <sup>2</sup>	1

<sup>1</sup> Logo Decal 052270 replaces Decal 016832 for AWMV (Rev. A9.00).

<sup>2</sup> Decals added Rev. A3.00.

# 4 Saw Head

## Head/Air Box Control Assembly

### 4.15 Head/Air Box Control Assembly

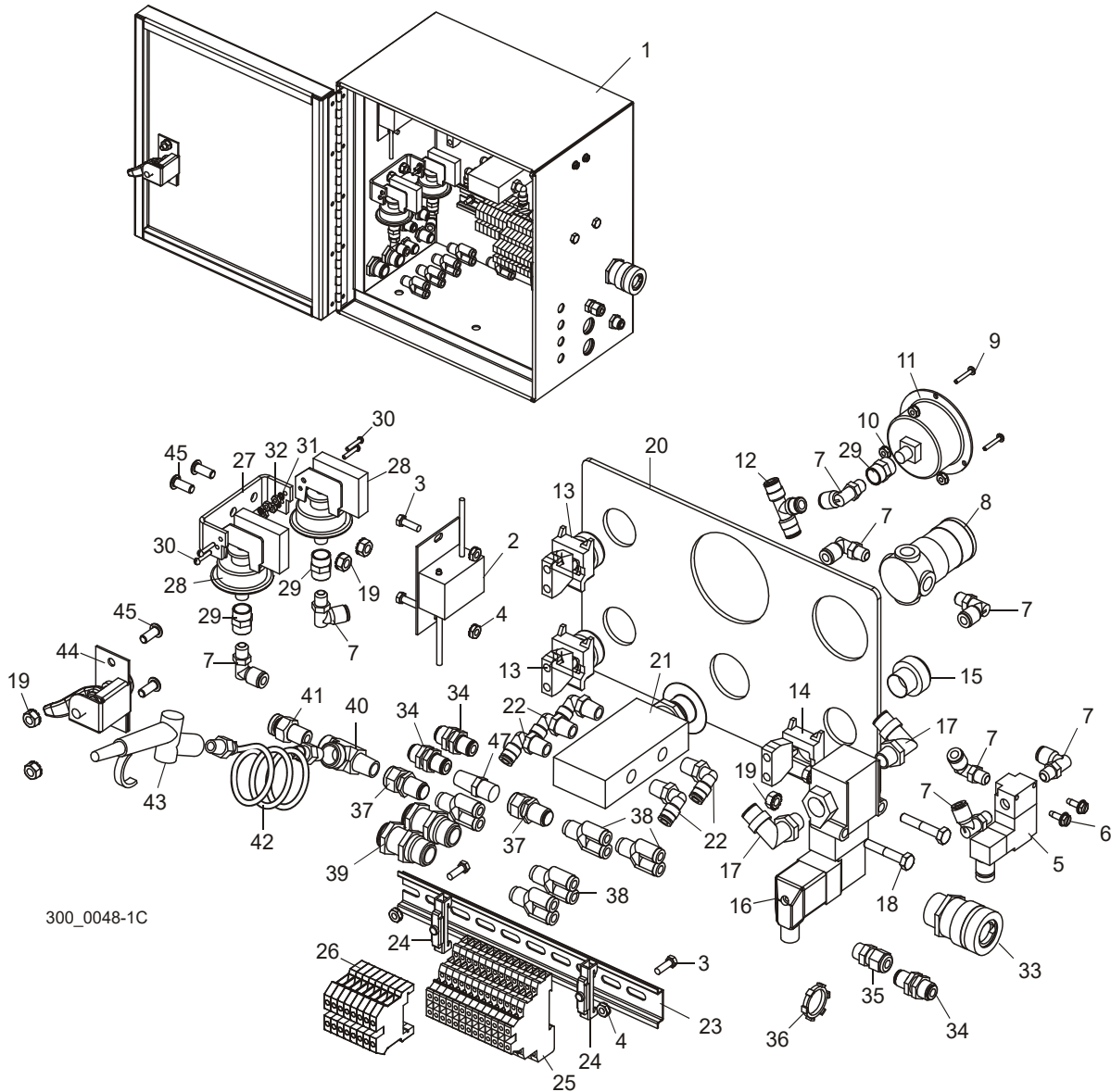

REF	DESCRIPTION (◆ Indicates Parts Available In Assemblies Only)	PART #	QTY.
	<b>CONTROL ASSEMBLY, HEAD/AIR BOX</b>	045244	1
1	Box Weldment, Head/Air	035569	1
2	Power Supply Assembly, Laser	052327 <sup>1</sup>	1
3	Screw, #10-24 x 5/8" Unslotted Indent Hex Head	F05004-18	4
4	Nut, #10-24 Hex Self-Locking	F05010-14	4
5	Valve, Air 3-Way 1/8" NPT DIN C Conn	045225	1
	Cable, 10M Form C DIN 24VDC w/LED	025233	1

6	Screw, #10-24 x 1/2" Self-Tapping Slotted Hex	F05015-7	2	
7	Fitting, 1/8" MPT x 1/4" Tube Swivel Elbow	P09736	8	
8	Regulator Kit, Air	045247 <sup>2</sup>	1	
	Regulator, 1/8" NPT Air	052509	1	
	Nut, Regulator Mount	052510	1	
	Plate, Regulator Mount Adaptor	049410	1	
9	Screw, #6-32 x 3/4" Socket Button Head Stainless	F05004-93	3	
10	Nut, #6-32 Hex Self-Locking	F05010-59	3	
11	Gauge, Air Pressure	042342	1	
12	Fitting, 1/4" Tube 'T'	P21544	1	
13	Light, Yellow 24V 22mm LED XB4 Pilot	024970-5	2	
14	Switch, 1NO 22mm XB4	025242	1	
15	Button, 22mm Mom Ext LED Yellow XB4 Switch	025237-53	1	
16	Valve Assembly, Blow-Off	042659	1	
	Cable, 5M Form A DIN 24VDC w/LED	024923	1	
17	Fitting, 3/8" NPT x 1/2" Tube Swivel Elbow	034009 <sup>3</sup>	2	
18	Bolt, 1/4-20 x 1 1/2" Hex Head Full Thread	F05005-31	2	
19	Nut, 1/4-20 Hex Self-Locking	F05010-9	6	
20	Decal, Head/Air Control Box	052274 <sup>4</sup>	1	
21	Valve, 4-Way Push/Pull 1/4" NPT	025301	1	
22	Fitting, 1/4" NPT x 1/4" Tube Elbow	P21519	5	
23	DIN Rail, 35mm x 7.5mm x 10" Steel Sym	024474-10	1	
24	Clamp, Metal DIN Rail	E22707	2	
25	Terminal Block, 3-Tier	024908	13	
26	Terminal Block, 1-Tier	024893	8	
27	Bracket, Pressure Switch Mount	042256	1	
28	Switch, Limit Pressure 60 PSI	045207	2	
29	Fitting, 1/8" FPT Coupling	P05748	3	
30	Screw, #4-40 x 5/8" Slotted Round Head	F05004-49	4	
31	Washer, #4 Split Lock	F05011-21	4	
32	Nut, #4 Hex	F05010-43	4	
33	Connector, .75 Hole x .63-.75 Cord Flex Strain	025186	1	
	Nut, 3/4" Conduit Lock	025198	1	
34	Fitting, 1/4" x 1/4" Tube Bulkhead	025234	1	
35	Connector, .5" Hole .064-.210 Cord	E23494	1	
36	Nut, 1/2" Conduit Lock	E20461	2	
37	Fitting, 1/4" Tube x 1/4" NPT Female Bulkhead	025235	2	
38	Fitting, 1/4" Tube "Y"	042546	5	
39	Fitting, 3/8" NPT x 1/2" Tube Bulkhead	034010 <sup>5</sup>	2	
40	Fitting, 1/4" Male Run Tee	P09141	1	
41	Fitting, 1/4" NPT x 3/8" Tube	P21559	1	
42	Hose, 1/4" x 6' Coiled Air	042453	1	
43	Nozzle, Air Spray	P02714	1	

# 4

## Saw Head

### Head/Air Box Control Assembly

44	Latch, Door	P20048	1	
45	Screw, 1/4-20 x 5/8" Button Socket Head	F05005-128	4	
	Washer, 7/8" SAE Flat	F05011-73	1	
	Harness Assembly, Blade Guide	025284	1	
	Harness Assembly, Motor Prox	025286	1	
	Harness Assembly, Start Prox	025287	1	
	Harness Assembly, Slow Prox	025288	1	
	Harness Assembly, Stop Prox	025289	1	
	Hose, 1/4" Chainflex Air	R01869-3	186"	
	Hose, 1/2" Chainflex Air	R01869-5	58"	
	Cable, Oiler	025233 <sup>6</sup>	1	

<sup>1</sup> Power Supply Assembly 052327 replaces 025124. Assembly includes power supply with installed wire terminals and installation instructions.

<sup>2</sup> Regulator Kit 045247 includes new Regulator 052509 (old regulator discontinued by vendor 10/05). Kit includes adaptor plate 049410 to allow installation of new regulator to box weldments built before change.

<sup>3</sup> 034009 3/8" NPT x 1/2" Tube Swivel Elbow Fitting added to accommodate blow-off assembly with 1/2" plumbing (Rev. A2.00)

<sup>4</sup> Head/Air Box Decal 052274 replaces Decal 042257 for AWMV (Rev. A9.00).

<sup>5</sup> 034010 3/8" NPT x 1/2" Tube Bulkhead Fitting replaces 042687 to accommodate blow-off assembly with 1/2" plumbing.

<sup>6</sup> Cable 025233 replaces Harness Assembly 050032 to accommodate new track rail oiler system (Rev. A3.00)



## SECTION 5 UP/DOWN SYSTEM

### 5.1 Mast Pads & Rollers

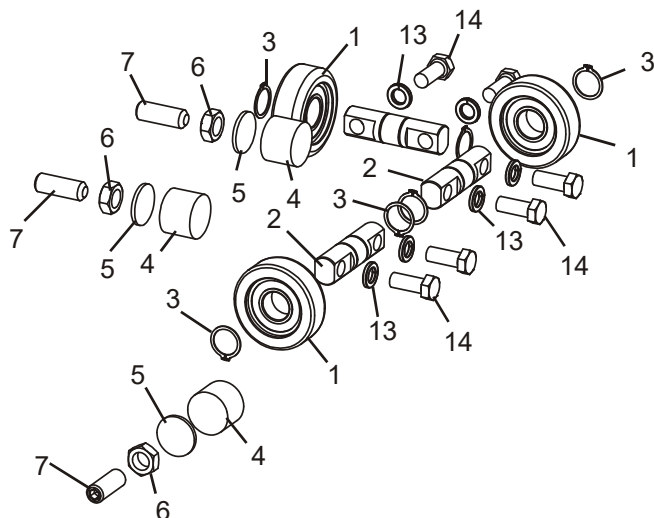

300\_0028-4

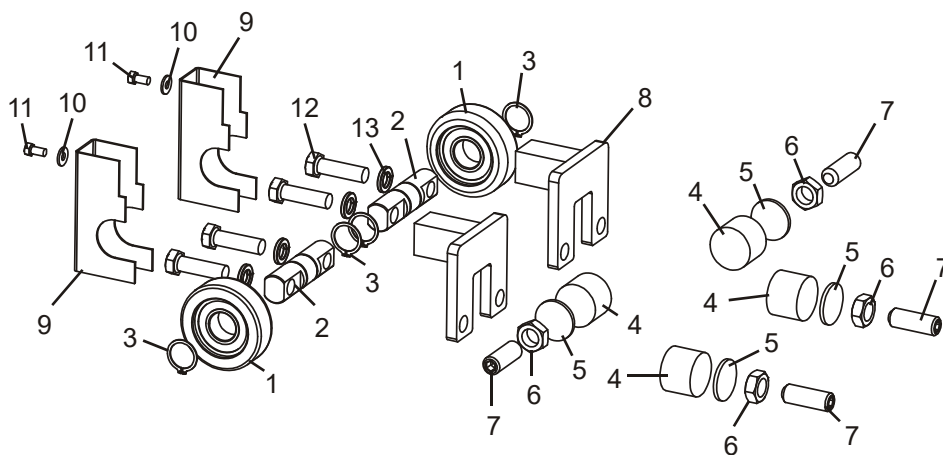

REF	DESCRIPTION (◆ Indicates Parts Available In Assemblies Only)	PART #	QTY.
1	BEARING, MG305DDA	023857	5
2	SHAFT, UP/DOWN MAST BEARING	023858	5
3	RING, 1" OUTSIDE RETAINING	F04254-15	10
4	PAD, ROUND NYLON	033098	7
5	PAD, NYLON BACKING	042432	7
6	NUT, 5/8-18 HEX JAM	F05010-11	7
7	SCREW, 5/8-18 X 1 3/4" SOCKET HEAD FLAT POINT SET	F05009-27	7
8	BRACKET WELDMENT, UP/DOWN BEARING MOUNT	045048	2
9	COVER, MAST BEARING	045047	2

# 5 Up/Down System

*Mast Pads & Rollers*

---

10	WASHER, 1/4" SAE FLAT	F05011-11	2	
11	BOLT, 1/4-20 X 1/2" HEX HEAD	F05005-15	2	
12	BOLT, 1/2-13 X 1 3/4" HEX HEAD GRADE 5	F05008-88	4	
13	WASHER, 1/2" SPLIT LOCK	F05011-9	10	
14	BOLT, 1/2-13 X 1 1/4" HEX HEAD GRADE 5	F05008-37	6	

## 5.2 Bearing Rails

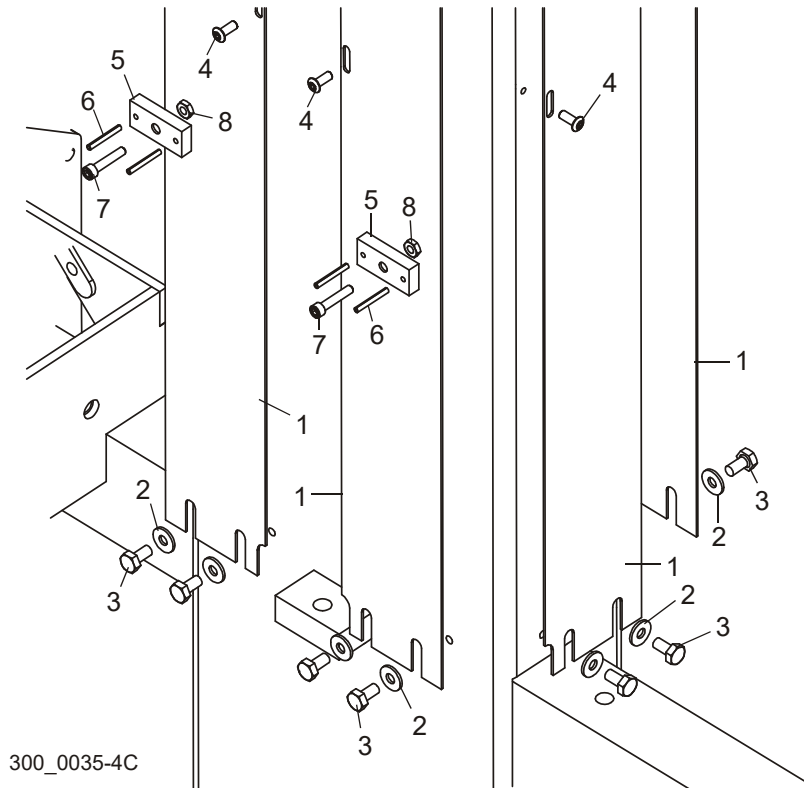

REF	DESCRIPTION (◆ Indicates Parts Available In Assemblies Only)	PART #	QTY.
	<b>RAIL KIT, UP/DOWN BEARING</b>	042788 <sup>1</sup>	1
1	Rail, Up/Down Bearing	042773	6
2	Washer, 1/4" SAE Flat	F05011-11	24
3	Bolt, 1/4-20 x 1/2" Hex Head	F05005-15	24
4	Screw, #10-24 x 1/2" Button Socket Head	F05004-35 <sup>1</sup>	18
5	<b>PAD, HEAD PLASTIC</b>	045056	2
6	<b>PIN, 1/8" X 1" ROLL</b>	F05012-34	4
7	<b>BOLT, #10-24 X 1" SOCKET HEAD</b>	F05004-2	2
8	<b>NUT, #10-24 HEX</b>	F05010-115	2

<sup>1</sup> Wider Bearing Rails 042773 replace 033139 Bearing Rails originally supplied before Rev. A3.00. All existing LT300 sawmills to be upfitted by Wood-Mizer (Kit #042788). Wider rails with additional mounting screws ensure rails are secured in position.

### 5.3 Up/Down Ballscrew Drive

LT300

Rev. B2.00+

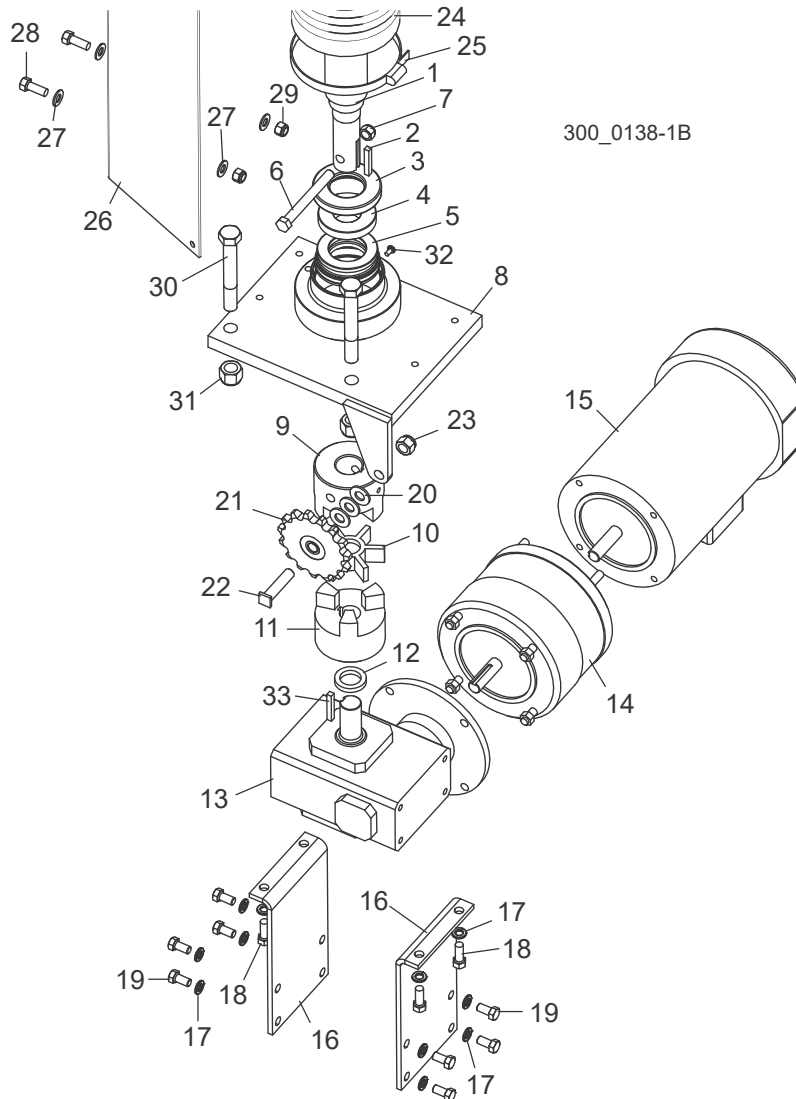

REF	DESCRIPTION (◆ Indicates Parts Available In Assemblies Only)	PART #	QTY.
	<b>DRIVE ASSEMBLY, BALLSCREW UP/DOWN</b>	042800	1
	Ballscrew Retrofit, Up/Down 30mm to 45mm	042901	1
	Ballscrew Assembly, Up/Down Service	036595	1
	Ballscrew Kit, Up/Down w/Nut	036596	1
1	Shaft, 2" x .5" Ballscrew	042858	1
	Nut, 2" BallScrew (Shown in <a href="#">Section 5.7</a> )	042791	1
	Grease, 10cc Syringe Up/Down Ballscrew	042399	1
2	Key, 1/4" Square x 1 5/8"	042810	1
3	Seal, 1 5/8" ID Thrust Bearing	042857	1

4	Spacer, Screw/Bearing Support	042856	1	
5	Spacer, 45 mm Thrust Bearing	110565	1	
6	Bolt, 7/16-14 x 4" Hex Head	F05007-180	1	
7	Nut, 7/16-14 Hex Nylon Lock	F05010-135	1	
Middle Ballscrew Mount Parts ( <a href="#">See Section 5.7</a> )				
8	Bracket Weldment, Up/Down 45mm Ballscrew Mount	017790	1	
9	Coupling, Modified L110 x 1 1/4" Body	017787	1	
10	Coupling, L110 Spider	042809	1	
11	Coupling, L110 x 1" Body	042820	1	
12	Spacer, 1" ID x 1 1/2" OD x .25" Thick	042805	1	
13	Gearbox, Up/Down Ballscrew IC60	042793	1	
14	Brake, Up/Down Electric 5/8-5/8 230/460V	042281	1	
15	Motor, 2HP 3P 230/460 56C Premium Efficiency	079197	1	
16	Plate, Up/Down Gearbox Mount	042794	2	
17	Washer, 3/8" Split Lock	F05011-4	14	
18	Bolt, 3/8-16 x 1" Hex Head	F05007-7	4	
19	Bolt, 3/8-16 x 3/4" Hex Head	F05007-27	8	
20	Washer, 1/2" SAE Flat	F05011-2	3	
21	Sprocket, Idler	042367	1	
22	Shaft, Idler Sprocket	016828	1	
23	Nut, 1/2-13 Hex Nylon Lock	F05010-8	1	
24	Bellows, 5" ID x 45" Ballscrew Protective	017777	1	
25	Clamp, Bellows Worm	042419	1	
26	Guard Weldment, Up/Down Bellows	017647	1	
27	Washer, 3/8" SAE Flat	F05011-3	4	
28	Bolt, 3/8-16 x 1" Hex Head	F05007-7	2	
29	Nut, 3/8-16 Hex Nylon Lock	F05010-10	2	
30	Bolt, 5/8-11 x 4 1/2" Hex Head Grade 5	F05009-10	2	
31	Nut, 5/8-11 Hex Nylon Lock	F05010-34	2	
32	Screw, #10-24 x 3/8" Phillips Pan Head	F05004-3	1	
33	Key, 1/4" Square x 1 5/8"	042810	1	
	Oil, 8 Oz. Mobil SHC634 Bottled Synthetic Gear	L04869-4	1 <sup>1</sup>	
Top Ballscrew Mount Parts ( <a href="#">See Section 5.9</a> )				

<sup>1</sup> 12 - 15 oz. required for complete oil replacement.

## 5.4 Up/Down Ballscrew Drive

LT300

Rev. A4.00 - B1.01

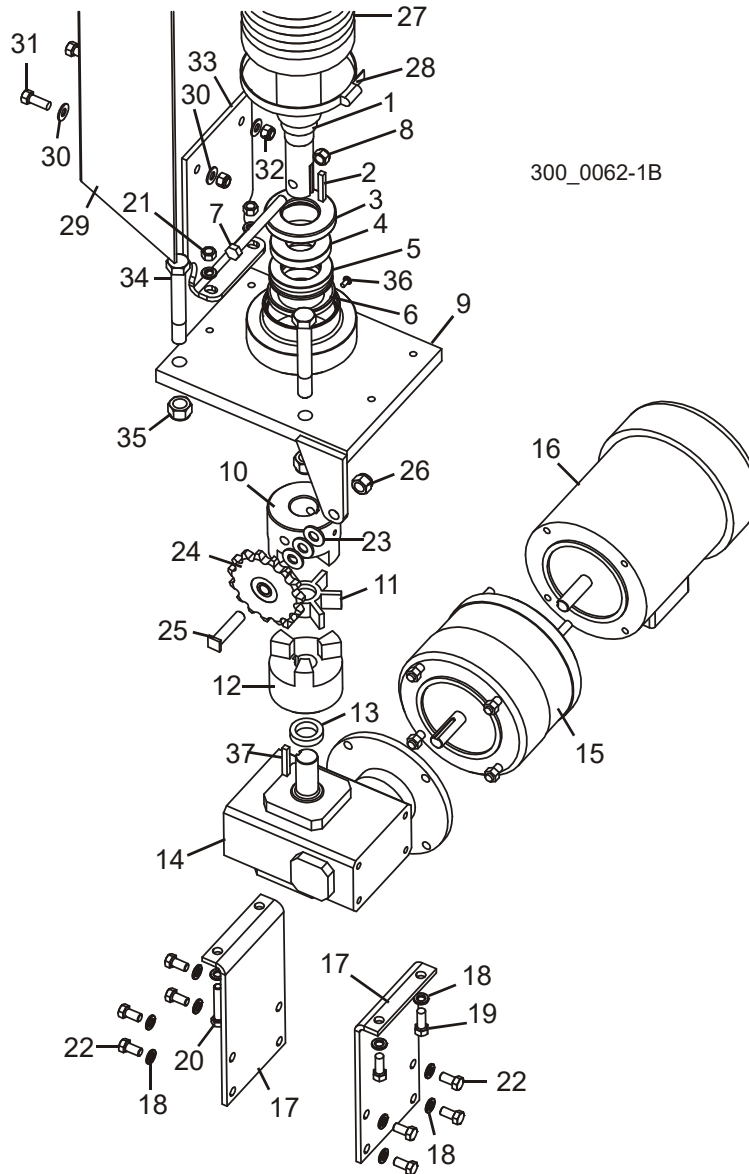

REF	DESCRIPTION (◆ Indicates Parts Available In Assemblies Only)	PART #	QTY.
	<b>DRIVE ASSEMBLY, BALLSCREW UP/DOWN</b>	042800	1
	Ballscrew Retrofit, Up/Down 30mm to 45mm	042901	1
	Ballscrew Assy, Up/Down Service	036595	1
	Ballscrew Kit, Up/Down w/Nut	036596	1
1	Shaft, 2" x .5" Ballscrew	042858	1
	Nut, 2" BallScrew (Shown in <a href="#">Section 5.7</a> )	042791	1
	Grease, 10cc Syringe Up/Down Ballscrew	042399	1

2	Key, 1/4" Square x 1 5/8"	042810	1	
3	Seal, 1 5/8" ID Thrust Bearing	042857	1	
4	Spacer, Screw/Bearing Support	042856	1	
5	Bearing, 45mm Self-Aligning Thrust Cone	042855-1	1	
6	Bearing, 45mm Self-Aligning Thrust Cup	042855-2	1	
7	Bolt, 7/16-14 x 4" Hex Head	F05007-180	1	
8	Nut, 7/16-14 Hex Nylon Lock	F05010-135	1	
Middle Ballscrew Mount Parts ( <a href="#">See Section 5.7</a> )				
9	Bracket Weldment, Up/Down 45mm Ballscrew Mount	017790	1	
10	Coupling, Modified L110 x 1 1/4" Body	017787	1	
11	Coupling, L110 Spider	042809	1	
12	Coupling, L110 x 1" Body	042820	1	
13	Spacer, 1" ID x 1 1/2" OD x .25" Thick	042805 <sup>1</sup>	1	
14	Gearbox, Up/Down Ballscrew IC60	042793	1	
15	Brake, Up/Down Electric 5/8-5/8 230/460V	042281	1	
16	Motor, 2HP 3PH 230/460V REFC 56C	042390	1	
17	Plate, Up/Down Gearbox Mount	042794	2	
18	Washer, 3/8" Split Lock	F05011-4	14	
19	Bolt, 3/8-16 x 1" Hex Head	F05007-7	2	
20	Bolt, 3/8-16 x 2" Hex Head Full Thread	F05007-16	2	
21	Nut, 3/8-16 Hex	F05010-1	2	
22	Bolt, 3/8-16 x 3/4" Hex Head	F05007-27	8	
23	Washer, 1/2" SAE Flat	F05011-2	3	
24	Sprocket, Idler	042367	1	
25	Shaft, Idler Sprocket	016828	1	
26	Nut, 1/2-13 Hex Nylon Lock	F05010-8	1	
27	Bellows, 5" ID x 45" Ballscrew Protective	017777	1	
28	Clamp, Bellows Worm	042419	1	
	Guard Assembly, Up/Down Bellows	042416	1	
29	Guard Weldment, Up/Down Bellows	017647	1	
30	Washer, 3/8" SAE Flat	F05011-3	4	
31	Bolt, 3/8-16 x 1" Hex Head	F05007-7	2	
32	Nut, 3/8-16 Hex Nylon Lock	F05010-10	2	
33	Plate, Bellows Guard Bottom	042417	1	
34	Bolt, 5/8-11 x 4 1/2" Hex Head Grade 5	F05009-10	2	
35	Nut, 5/8-11 Hex Nylon Lock	F05010-34	2	
36	Screw, #10-24 x 3/8" Phillips Pan Head	F05004-3	1	
37	Key, 1/4" Square x 1 5/8"	042810	1	
	Oil, 8 Oz. Mobil SHC634 Bottled Synthetic Gear	L04869-4	1 <sup>2</sup>	
Top Ballscrew Mount Parts ( <a href="#">See Section 5.9</a> )				

<sup>1</sup> 042805 spacer replaces 017778 .35" spacer originally supplied before 4/03. Thinner spacer provides proper clearance between gearbox and coupler.

<sup>2</sup> 12 - 15 oz. required for complete oil replacement.

### 5.5 Up/Down Ballscrew Drive

LT300

Rev. A3.00

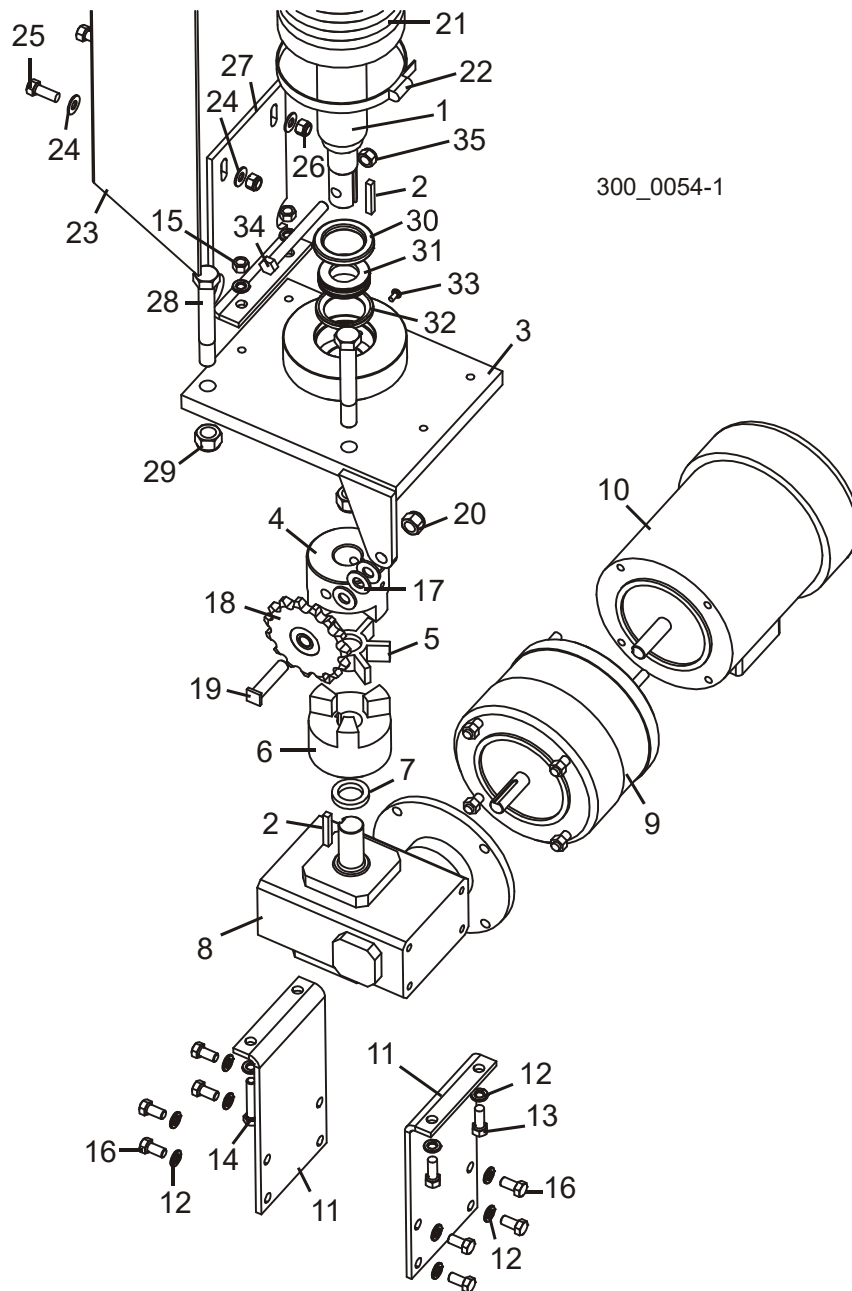

REF	DESCRIPTION (◆ Indicates Parts Available In Assemblies Only)	PART #	QTY.
	GREASE, 10CC SYRINGE UP/DOWN BALLSCREW	042399	1
	DRIVE ASSEMBLY, BALLSCREW UP/DOWN	042800 <sup>1</sup>	1
1	Shaft, 2" Ballscrew	042790 <sup>1</sup>	1



2	Key, 1/4" Square x 1 5/8"	042810	2	
3	Bracket Weldment, Up/Down Ballscrew Mount	042802 <sup>1</sup>	1	
4	Coupling, Modified L110 x 1 1/8" Body	042812 <sup>1</sup>	1	
5	Coupling, L110 Spider	042809	1	
6	Coupling, L110 x 1" Body	042820	1	
7	Spacer, 1" ID x 1 1/2" OD x 1/4" Thick	042805 <sup>1</sup>	1	
8	Gearbox, Up/Down Ballscrew IC60	042793	1	
9	Brake, Up/Down Electric 5/8-5/8 230/460V	042281	1	
10	Motor, 2HP 3PH 230/460V REFC 56C	042390	1	
11	Plate, Up/Down Gearbox Mount	042794	2	
12	Washer, 3/8" Split Lock	F05011-4	14	
13	Bolt, 3/8-16 x 1" Hex Head	F05007-7	2	
14	Bolt, 3/8-16 x 2" Hex Head Full Thread	F05007-16	2	
15	Nut, 3/8-16 Hex	F05010-1	2	
16	Bolt, 3/8-16 x 3/4" Hex Head	F05007-27	8	
17	Washer, 1/2" SAE Flat	F05011-2	3	
18	Sprocket, Idler	042367	1	
19	Shaft, Idler Sprocket	016828	1	
20	Nut, 1/2-13 Hex Nylon Lock	F05010-8	1	
21	Bellows, 5" ID x 45" Ballscrew Protective	017777	1	
22	Clamp, Bellows Worm	042419	1	
	Guard Assembly, Up/Down Bellows	042416	1	
23	Guard Weldment, Up/Down Bellows	017647	1	
24	Washer, 3/8" SAE Flat	F05011-3	4	
25	Bolt, 3/8-16 x 1" Hex Head	F05007-7	2	
26	Nut, 3/8-16 Hex Nylon Lock	F05010-10	2	
27	Plate, Bellows Guard Bottom	042417	1	
28	Bolt, 5/8-11 x 4 1/2" Hex Head Grade 5	F05009-10	2	
29	Nut, 5/8-11 Hex Nylon Lock	F05010-34	2	
30	Seal, 1 5/8" ID Thrust Bearing	017774 <sup>1</sup>	1	
31	Bearing, 30mm Self-Aligning Thrust Cone	042789-1 <sup>1</sup>	1	
32	Bearing, 30mm Self-Aligning Thrust Cup	042789-2 <sup>1</sup>	1	
33	Screw, #10-24 x 3/8" Phillips Pan Head	F05004-3	1	
34	Bolt, 7/16-14 x 4" Hex Head	F05007-180	1	
35	Nut, 7/16-14 Hex Nylon Lock	F05010-135	1	
	Oil, 8 Oz. Mobil SHC634 Bottled Synthetic Gear	L04869-4	1 <sup>2</sup>	
	Middle Ballscrew Mount Parts ( <a href="#">See Section 5.7</a> )			
	Top Ballscrew Mount Parts ( <a href="#">See Section 5.9</a> )			

<sup>1</sup> Up/Down Drive Assembly 042800 revised Rev. A4.00. Ballscrew, Mount Bracket Weldment, Bearings, Spacers, Seal and Coupling Body revised for 45mm Bearings. Use kit 042901 to retrofit previous revisions ([See Section 5.5](#)).

<sup>2</sup> 12 - 15 oz. required for complete oil replacement.

## 5.6 Up/Down Ballscrew Drive

LT300

Rev. A1.00 - A2.01

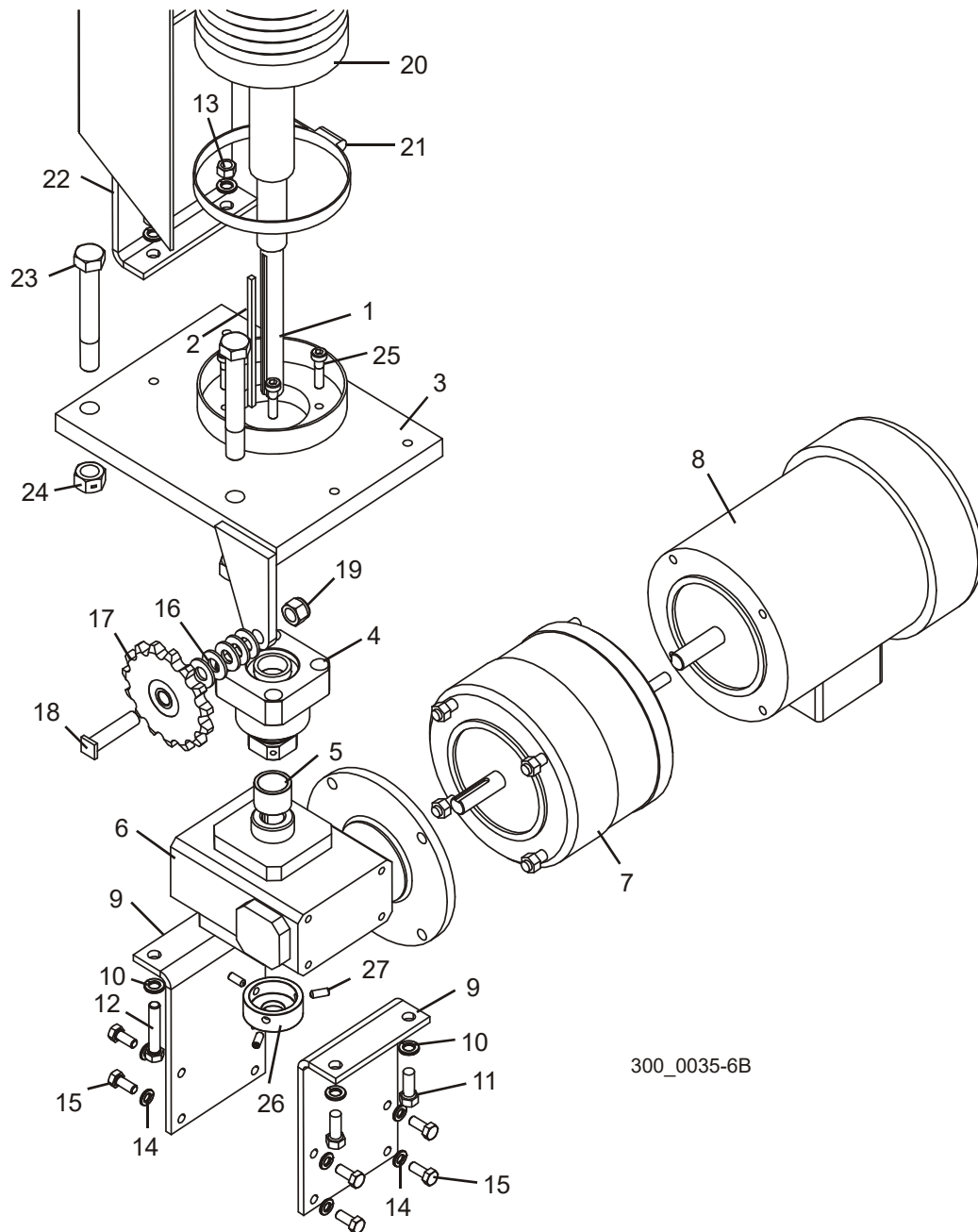

300\_0035-6B

REF	DESCRIPTION (◆ Indicates Parts Available In Assemblies Only)	PART #	QTY.	
	GREASE, 10CC SYRINGE UP/DOWN BALLSCREW	042399	1	
	DRIVE ASSEMBLY, BALLSCREW UP/DOWN	042410 <sup>1</sup>	1	◆
1	Shaft, 1 1/2" Ballscrew	042285 <sup>1</sup>	1	◆

2	Key, 3/16" Square x 5 1/2"	042275 <sup>1</sup>	1	◆
3	Bracket Weldment, Up/Down Ballscrew Mount	042402 <sup>1</sup>	1	◆
4	Bearing, Up/Down Ballscrew Thrust	042287 <sup>1</sup>	1	◆
5	Spacer, Up/Down Ballscrew	042547 <sup>1</sup>	1	◆
6	Gearbox, Up/Down Ballscrew	042283 <sup>1</sup>	1	◆
7	Brake, Up/Down Electric 5/8-5/8 230/460V	042281	1	
8	Motor, 2HP 3PH 230/460V REFC 56C	042390	1	
9	Plate, Up/Down Gearbox Mount	042401 <sup>1</sup>	2	◆
10	Washer, 3/8" Split Lock	F05011-4	6	
11	Bolt, 3/8-16 x 1" Hex Head	F05007-7	2	
12	Bolt, 3/8-16 x 2" Hex Head Full Thread	F05007-16	2	
13	Nut, 3/8-16 Hex	F05010-1	2	
14	Washer, 5/16" Split Lock	F05011-13	8	
15	Bolt, 5/16-18 x 3/4" Hex Head	F05006-5	8	
16	Washer, 1/2" SAE Flat	F05011-2	5	
17	Sprocket, Idler	042367	1	
18	Shaft, Idler Sprocket	016828	1	
19	Nut, 1/2-13 Hex Nylon Lock	F05010-8	1	
20	Bellows, Ballscrew Protective	042270	1	
21	Clamp, Bellows Worm	042419	1	
22	Guard Weldment, Up/Down Bellows	042416	1	
23	Bolt, 5/8-11 x 4 1/2" Hex Head Grade 5	F05009-10	2	
24	Nut, 5/8-11 Hex Lock	F05010-4	2	
25	Bolt, 8mm x 1.25 x 32mm Socket Head	F81002-12	4	
26	Collar, Up/Down Shaft Key Retaining	050211 <sup>2</sup>	1	◆
27	Screw, 1/4-28 x 5/8" Cup Point Socket Set	F05005-151 <sup>2</sup>	3	
	Oil, 8 Oz. Mobil SHC634 Bottled Synthetic Gear	L04869-4	1 <sup>3</sup>	
	Middle Ballscrew Mount Parts ( <a href="#">See Section 5.7</a> )			
	Top Ballscrew Mount Parts ( <a href="#">See Section 5.9</a> )			

<sup>1</sup> 1 1/2" Ballscrew Assembly 042410 replaced with 2" Ballscrew Assembly 042800 (Rev. A3.00). All LT300 sawmills to be upgraded to 2" system to improve durability. Component parts obsolete. Use kit 042901 to retrofit previous revisions ([See Section 5.4](#)).

<sup>2</sup> Collar and screws added to retain shaft key, preventing it from working loose and possibly damaging wires (9/01). Component parts obsolete. Upgrade to 2" ballscrew system

<sup>3</sup> 8 - 11 oz. required for complete oil replacement (original gearbox only; 12 - 15 oz. required for replacement gearbox).

**5** Up/Down System  
*Ballscrew Mount (Middle)*

**5.7** Ballscrew Mount (Middle)

LT300

Rev. A3.00+

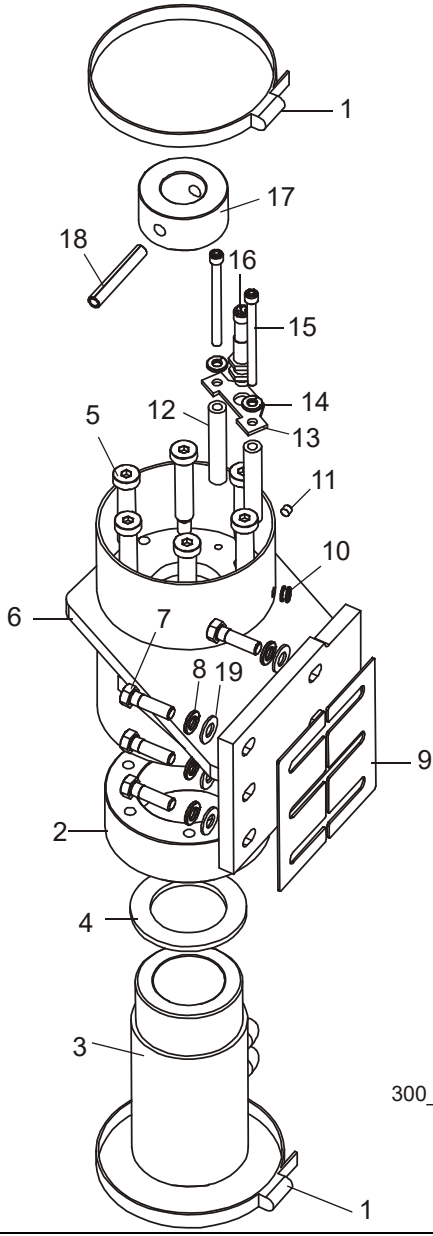

300\_0062-2

REF	DESCRIPTION (◆ Indicates Parts Available In Assemblies Only)	PART #	QTY.	
1	CLAMP, BALLSCREW BELLOWS	042419	2	
	<b>BALLSCREW ASSEMBLY, UP/DOWN SERVICE</b>	036595	1	
	Lower Ballscrew Mount Parts ( <a href="#">See Section 5.3</a> )			
2	Flange, 2" BallScrew Nut	042792	1	
	Ballscrew Kit, Up/Down w/Nut	036596	1	
	Shaft, 2" x .5" Ballscrew (Shown in <a href="#">Section 5.3</a> )	042858	1	

<b>3</b>	Nut, 2" BallScrew	042791	1	
	Grease, 10cc Syringe Up/Down Ballscrew	042399	1	
<b>4</b>	Plate, BallScrew Nut Wear	042816	1	
<b>5</b>	Bolt, 1/2" x 2 1/4" Shoulder	F05008-136	6	
<b>6</b>	Bracket Weldment, Middle Ballscrew Mount	042819	1	
<b>7</b>	Bolt, 3/8-16 x 1 1/4" Hex Head Grade 5	F05007-123	6	
<b>8</b>	Washer, 3/8" Split Lock	F05011-4	6	
<b>9</b>	Plate, Ballscrew Mount Shim	016800	2	
<b>10</b>	Grommet, 9/32" Hole x 3/16" ID x 7/16" OD	042825	1	
<b>11</b>	Screw, 1/4-28 x 1/4" Brass Tip Socket Set	F05005-42	1	
<b>12</b>	Spacer, 17/64" ID x 1/2" OD x 2 3/4" Long	042821	2	
<b>13</b>	Plate, BallScrew Sensor Mount	042815	1	
<b>14</b>	Washer. 1/4" Split Lock	F05011-14	2	
<b>15</b>	Bolt, 1/4-20 x 3 1/4" Socket head	F05005-154	2	
<b>16</b>	Sensor, 12mm Unshielded Extended w/connector Proximity	025041 <sup>1</sup>	1	
<b>17</b>	Collar, Ballscrew Nut Stop	042822	1	
<b>18</b>	Pin, 3/8" x 2 1/2" Roll	F05012-114	1	
<b>19</b>	Washer, 3/8" SAE Flat	F05011-3	6	

<sup>1</sup> Sensor 025041 included in service kit 036595 but not Up/Down Assembly 042800 (to accommodate European structure, 4/04).

## 5.8 Ballscrew Mount (Middle)

LT300

Rev. A1.00 - A2.01

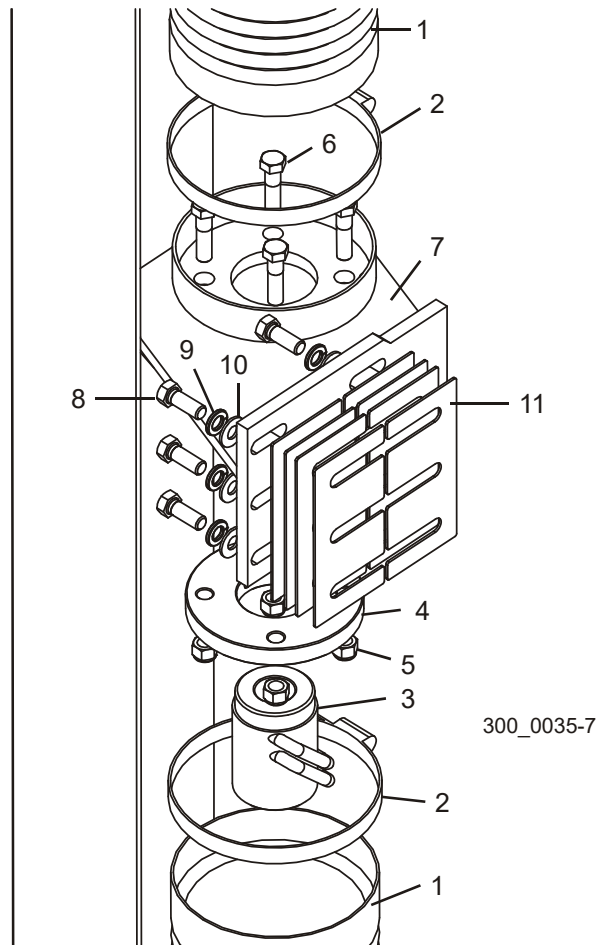

REF	DESCRIPTION (◆ Indicates Parts Available In Assemblies Only)	PART #	QTY.
1	<b>BELLOWS, BALL SCREW PROTECTIVE</b>	042270	2
2	<b>CLAMP, BALLSCREW BELLOWS</b>	042419	4
	<b>NUT ASSEMBLY, BALLSCREW FLANGED</b>	042277	1
3	Nut, Ballscrew	042286	1
4	Flange, Ballscrew Nut	042278	1
5	<b>NUT, 3/8-16 HEX NYLON LOCK</b>	F05010-10	4
6	<b>BOLT, 3/8-16 X 1 1/2" HEX HEAD GRADE 5</b>	F05007-78	4
7	<b>BRACKET WELDMENT, MIDDLE BALLSCREW MOUNT</b>	042273	1
8	<b>BOLT, 3/8-16 X 1" HEX HEAD GRADE 5</b>	F05007-87	6
9	<b>WASHER, 3/8" SPLIT LOCK</b>	F05011-4	6
10	<b>WASHER, 3/8" SAE FLAT</b>	F05011-3	6
11	<b>PLATE, BALLSCREW NUT SHIM</b>	016800	6

## 5.9 Ballscrew Mount (Top)

LT300

Rev. A3.00+

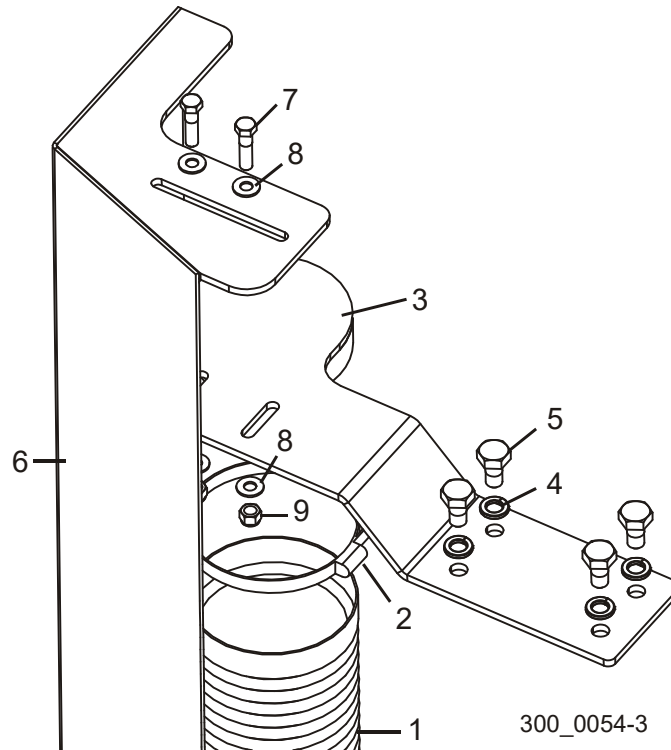

REF	DESCRIPTION (◆ Indicates Parts Available In Assemblies Only)	PART #	QTY.
1	BELLOWS, 5" ID X 62" BALLSCREW PROTECTIVE	042823	1
2	CLAMP, BALLSCREW BELLOWS	042419	1
3	MOUNT WELDMENT, TOP BELLOWS	042814	1
4	WASHER, 1/2" SPLIT LOCK	F05011-9	4
5	BOLT, 1/2-13 X 1" HEX HEAD	F05008-50	4
6	GUARD PARTS ( <a href="#">See Section 5.3</a> )		
7	BOLT, 3/8-16 X 1 1/2" HEX HEAD	F05007-3	2
8	WASHER, 3/8" SAE FLAT	F05011-3	4
9	NUT, 3/8-16 HEX NYLON LOCK	F05010-10	2

## 5.10 Ballscrew Mount (Top)

LT300

Rev. A1.00 - A2.01

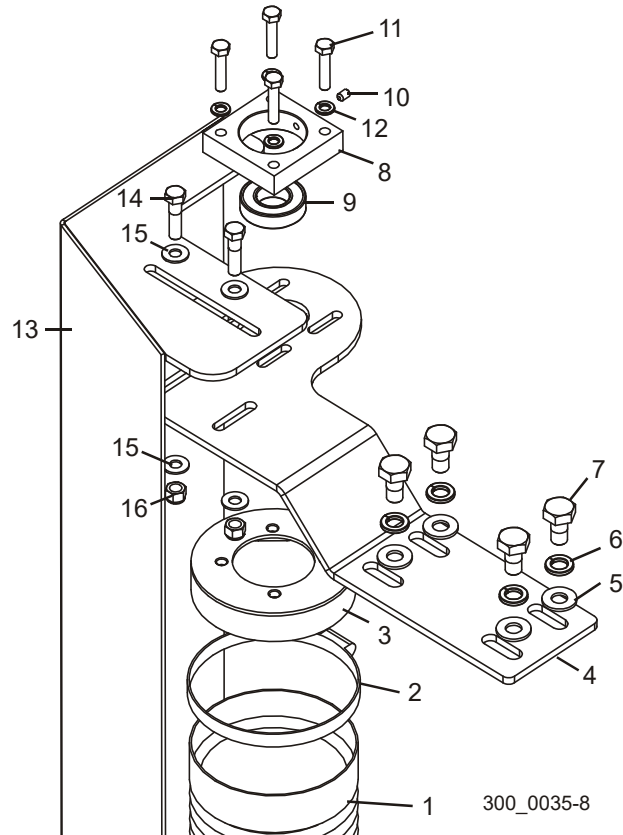

REF	DESCRIPTION (◆ Indicates Parts Available In Assemblies Only)	PART #	QTY.
1	BELLOWS, BALL SCREW PROTECTIVE	042270	2
2	CLAMP, BALLSCREW BELLOWS	042419	4
3	MOUNT WELDMENT, TOP BELLOWS	042265	1
4	PLATE, TOP BELLOWS MOUNT	042405	1
5	WASHER, 1/2" SAE FLAT	F05011-2	4
6	WASHER, 1/2" SPLIT LOCK	F05011-9	4
7	BOLT, 1/2-13 X 1" HEX HEAD	F05008-50	4
8	HOUSING, BALLSCREW TOP BEARING	042280	1
9	BEARING, R16 SEALED	042360	1
10	SCREW, 1/4-20 X 3/8" CUP POINT SOCKET SET	F05005-47	1
11	BOLT, 5/16-18 X 1 1/2" HEX HEAD FULL THREAD	F05006-2	4
12	WASHER, 5/16" SPLIT LOCK	F05011-13	4
13	GUARD PARTS ( <a href="#">See Section 5.6</a> )		
14	BOLT, 3/8-16 X 1 1/2" HEX HEAD	F05007-3	2
15	WASHER, 3/8" SAE FLAT	F05011-3	4
16	NUT, 3/8-16 HEX NYLON LOCK	F05010-10	2



## 5.11 Transducer & Head Stop

*LT300*

*Rev. B4.00+*

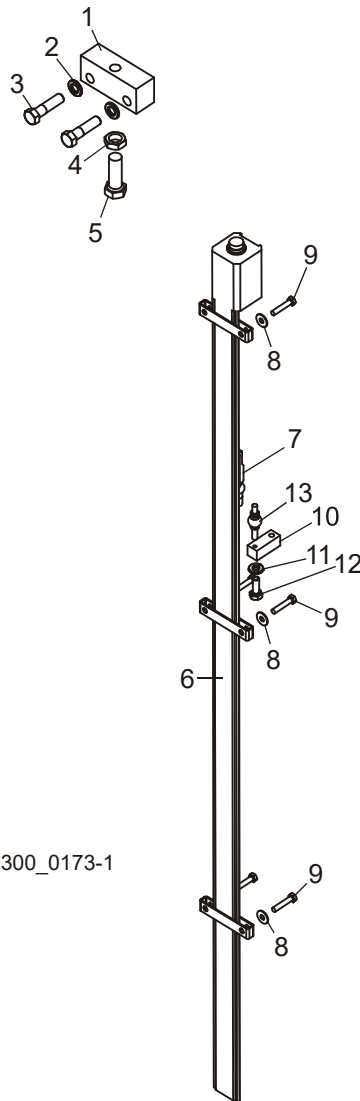

REF	DESCRIPTION (◆ Indicates Parts Available In Assemblies Only)	PART #	QTY.	
1	<b>BLOCK, HEAD STOP</b>	023886	1	
2	<b>WASHER, 3/8" SPLIT LOCK</b>	F05011-4	5	
3	<b>BOLT, 3/8-16 X 1 1/2 HEX HEAD GRADE 5</b>	F05007-78	5	
4	<b>NUT, 1/2-13 HEX JAM</b>	F05010-31	1	
5	<b>BOLT, 1/2-13 X 1 1/2" HEX HEAD GRADE 5</b>	F05008-33	1	
6	<b>SENSOR, 36" 4-20MA CAPTIVE SLIDE TRANSDUCER</b>	025042	1	
	Transducer Mounting Bracket	BAM0204	3	
7	Magnet, Captive Sliding Transducer (Balluff)	052470	1	

## 5 Up/Down System

### *Transducer & Head Stop*

---

	<b>CABLE ASSEMBLY, LT300 TRANSDUCER SENSOR</b>	050981 <sup>1</sup>	1	
<b>8</b>	<b>WASHER, #10 SAE FLAT</b>	F05011-18	6	
<b>9</b>	<b>BOLT, #10-24 X 1" UNSLOTTED HEX HEAD</b>	F05004-156	6	
<b>10</b>	<b>BLOCK, TRANSDUCER SLIDE</b>	042436	1	
<b>11</b>	<b>WASHER, 1/4" SPLIT LOCK</b>	F05011-14	1	
<b>12</b>	<b>BOLT, 1/4-20 X 3/4" HEX HEAD FULL THREAD</b>	F05005-1	1	
<b>13</b>	<b>PIVOT, BALL JOINTED ARM</b>	025197	1	

<sup>1</sup> Replaces 050974 used prior to 6/12 (Similar Parts)

## 5.12 Transducer & Head Stop

*LT300*

*Rev. B2.00 - B3.02*

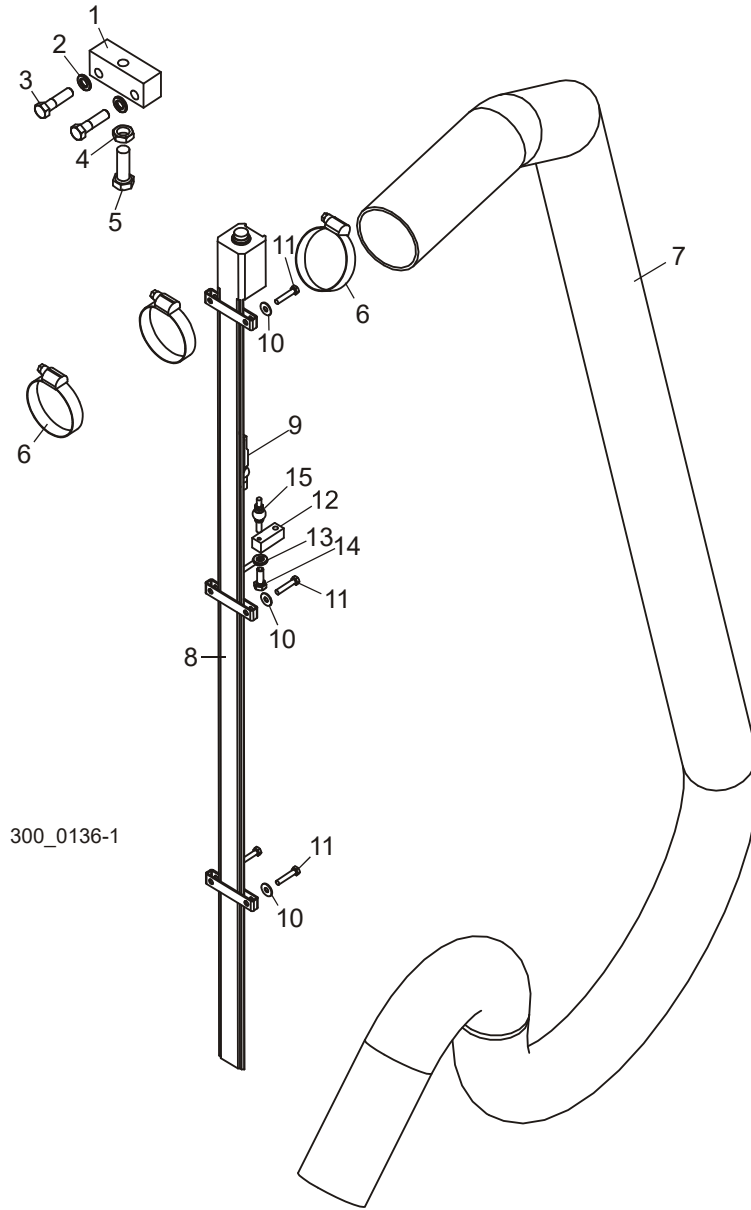

REF	DESCRIPTION (◆ Indicates Parts Available In Assemblies Only)	PART #	QTY.
1	<b>BLOCK, HEAD STOP</b>	023886	1
2	<b>WASHER, 3/8" SPLIT LOCK</b>	F05011-4	5
3	<b>BOLT, 3/8-16 X 1 1/2 HEX HEAD GRADE 5</b>	F05007-78	5
4	<b>NUT, 1/2-13 HEX JAM</b>	F05010-31	1
5	<b>BOLT, 1/2-13 X 1 1/2" HEX HEAD GRADE 5</b>	F05008-33	1
6	<b>CLAMP, 2 1/2" WORM</b>	P09895	3

## 5 Up/Down System

### Transducer & Head Stop

7	<b>SLEEVE, WIRE HARNESS</b>	042422	1	
8	<b>SENSOR, 36" 4-20MA CAPTIVE SLIDE TRANSDUCER</b>	025042	1	
	Transducer Mounting Bracket	BAM0204	3	
9	Magnet, Captive Sliding Transducer (Balluff)	052470	1	
	<b>CABLE ASSEMBLY, LT300 TRANSDUCER SENSOR</b>	050981 <sup>1</sup>	1	
10	<b>WASHER, #10 SAE FLAT</b>	F05011-18	6	
11	<b>BOLT, #10-24 X 1" UNSLOTTED HEX HEAD</b>	F05004-156	6	
12	<b>BLOCK, TRANSDUCER SLIDE</b>	042436	1	
13	<b>WASHER, 1/4" SPLIT LOCK</b>	F05011-14	1	
14	<b>BOLT, 1/4-20 X 3/4" HEX HEAD FULL THREAD</b>	F05005-1	1	
15	<b>PIVOT, BALL JOINTED ARM</b>	025197	1	

<sup>1</sup> Replaces 050974 used prior to 6/12 (Similar Parts)

### 5.13 Transducer & Head Stop

LT300

Rev. A9.02 - B1.01

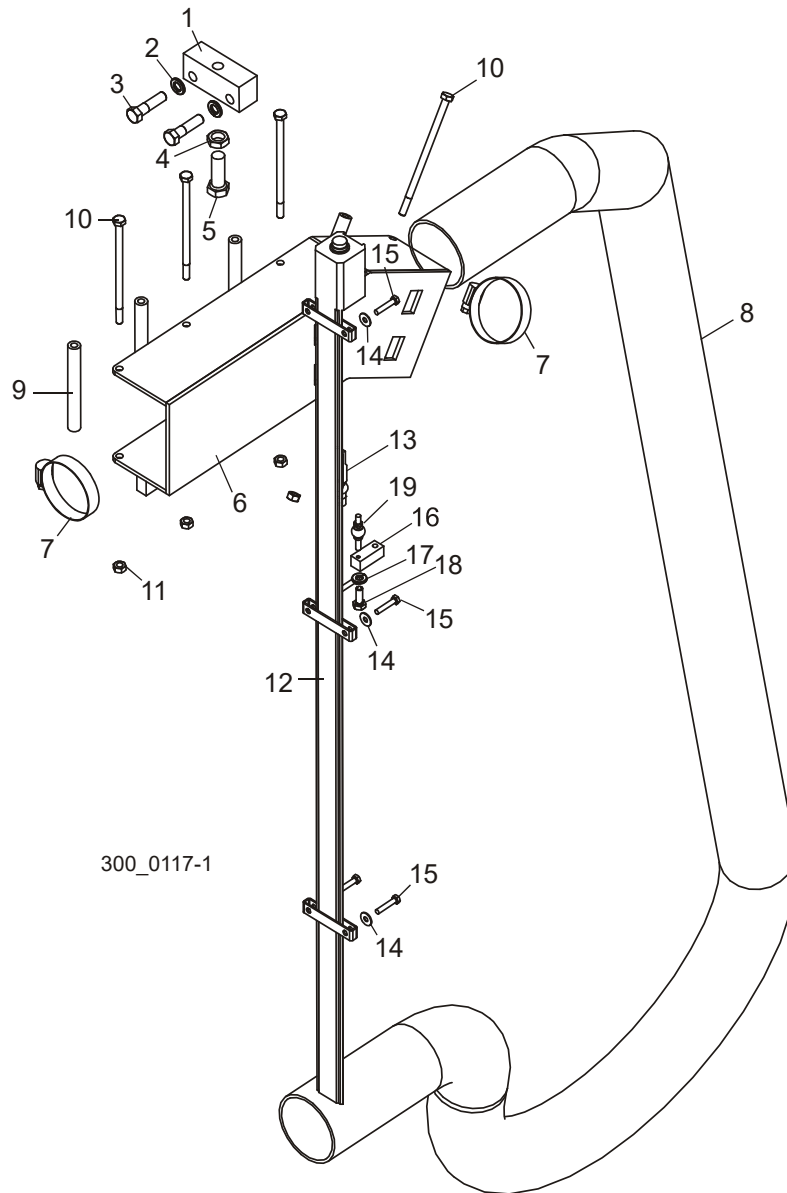

REF	DESCRIPTION (◆ Indicates Parts Available In Assemblies Only)	PART #	QTY.
1	BLOCK, HEAD STOP	023886	1
2	WASHER, 3/8" SPLIT LOCK	F05011-4	5
3	BOLT, 3/8-16 X 1 1/2 HEX HEAD GRADE 5	F05007-78	5
4	NUT, 1/2-13 HEX JAM	F05010-31	1
5	BOLT, 1/2-13 X 1 1/2" HEX HEAD GRADE 5	F05008-33	1
6	BRACKET WELDMENT, TOP WIREWAY	042148	1

## 5 Up/Down System Transducer & Head Stop

7	CLAMP, 2" WORM	P11633	2	
8	SLEEVE, WIRE HARNESS	042422	1	
9	SPACER, WIREWAY	042111	4	
10	BOLT, 1/4-20 X 5" HEX HEAD	F05005-146	4	
11	NUT, 1/4-20 HEX LOCK	F05010-21	4	
12	SENSOR, 36" 4-20MA CAPTIVE SLIDE TRANSDUCER	025042 <sup>1</sup>	1	
	Transducer Mounting Bracket	BAM0204	3	
13	Magnet, Captive Sliding Transducer (Balluff)	052470 <sup>1</sup>	1	
	CABLE ASSEMBLY, LT300 TRANSDUCER SENSOR	050981 <sup>2</sup>	1	
14	WASHER, #10 SAE FLAT	F05011-18 <sup>1</sup>	6	
15	BOLT, #10-24 X 1" UNSLOTTED HEX HEAD	F05004-156 <sup>1</sup>	6	
16	BLOCK, TRANSDUCER SLIDE	042436	1	
17	WASHER, 1/4" SPLIT LOCK	F05011-14	1	
18	BOLT, 1/4-20 X 3/4" HEX HEAD FULL THREAD	F05005-1	1	
19	PIVOT, BALL JOINTED ARM	025197	1	

<sup>1</sup> 025042 Sensor changed from MTS to Balluff Rev. A9.02 (Vendor discontinued). Requires new mounting bolts and washers.

<sup>2</sup> Replaces 050974 used prior to 6/12 (Similar Parts)

### 5.14 Transducer & Head Stop

LT300

Rev. A1.00 - A9.01

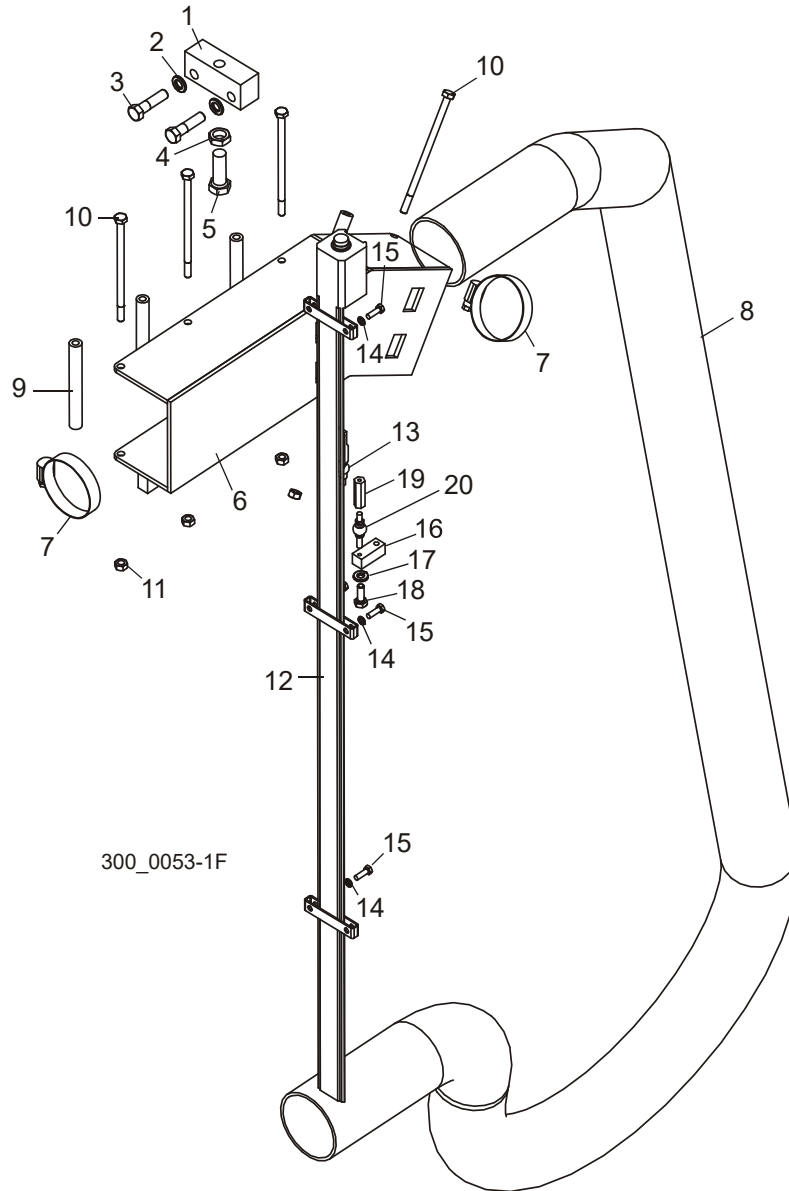

REF	DESCRIPTION (◆ Indicates Parts Available In Assemblies Only)	PART #	QTY.
1	BLOCK, HEAD STOP	023886	1
2	WASHER, 3/8" SPLIT LOCK	F05011-4	5
3	BOLT, 3/8-16 X 1 1/2 HEX HEAD GRADE 5	F05007-78	5
4	NUT, 1/2-13 HEX JAM	F05010-31	1
5	BOLT, 1/2-13 X 1 1/2" HEX HEAD GRADE 5	F05008-33	1
6	BRACKET WELDMENT, TOP WIREWAY	042148	1

## 5

## Up/Down System

### Transducer & Head Stop

7	CLAMP, 2" WORM	P11633	2	
8	SLEEVE, WIRE HARNESS	042422	1	
9	SPACER, WIREWAY	042111	4	
10	BOLT, 1/4-20 X 5" HEX HEAD	F05005-146	4	
11	NUT, 1/4-20 HEX LOCK	F05010-21	4	
12	SENSOR, 36" 4-20MA CAPTIVE SLIDE TRANSDUCER	025042 <sup>1</sup>	1	
	Transducer Mounting Bracket	BAM0204	3	
13	Magnet, Captive Sliding Transducer (MTS)	038431 <sup>1</sup>	1	
	CABLE ASSEMBLY, LT300 TRANSDUCER SENSOR	050981 <sup>2</sup>	1	
14	WASHER, #10 SPLIT LOCK	F05011-20 <sup>1</sup>	6	
15	BOLT, #10-24 X 5/8" HEX HEAD	F05004-18 <sup>1</sup>	6	
16	BLOCK, TRANSDUCER SLIDE	042436	1	
17	WASHER, 1/4" SPLIT LOCK	F05011-14	1	
18	BOLT, 1/4-20 X 3/4" HEX HEAD FULL THREAD	F05005-1	1	
19	NUT, TRANSDUCER COUPLING	042437	1	
20	PIVOT, BALL JOINTED ARM	025197	1	

<sup>1</sup> 025042 Sensor changed from MTS to Balluff Rev. A9.02 (Vendor discontinued). Use MTS mounting brackets and hardware to mount Balluff sensor or replace mounting hardware. Use Balluff magnet 052470 to service new transducer ([See Section 5.13](#)).

<sup>2</sup> Replaces 025285 supplied prior to 6/04 and 050974 supplied prior to 6/12 (Similar parts).



**SECTION 6 POWER FEED**

**6.1 Upper Track Rollers**

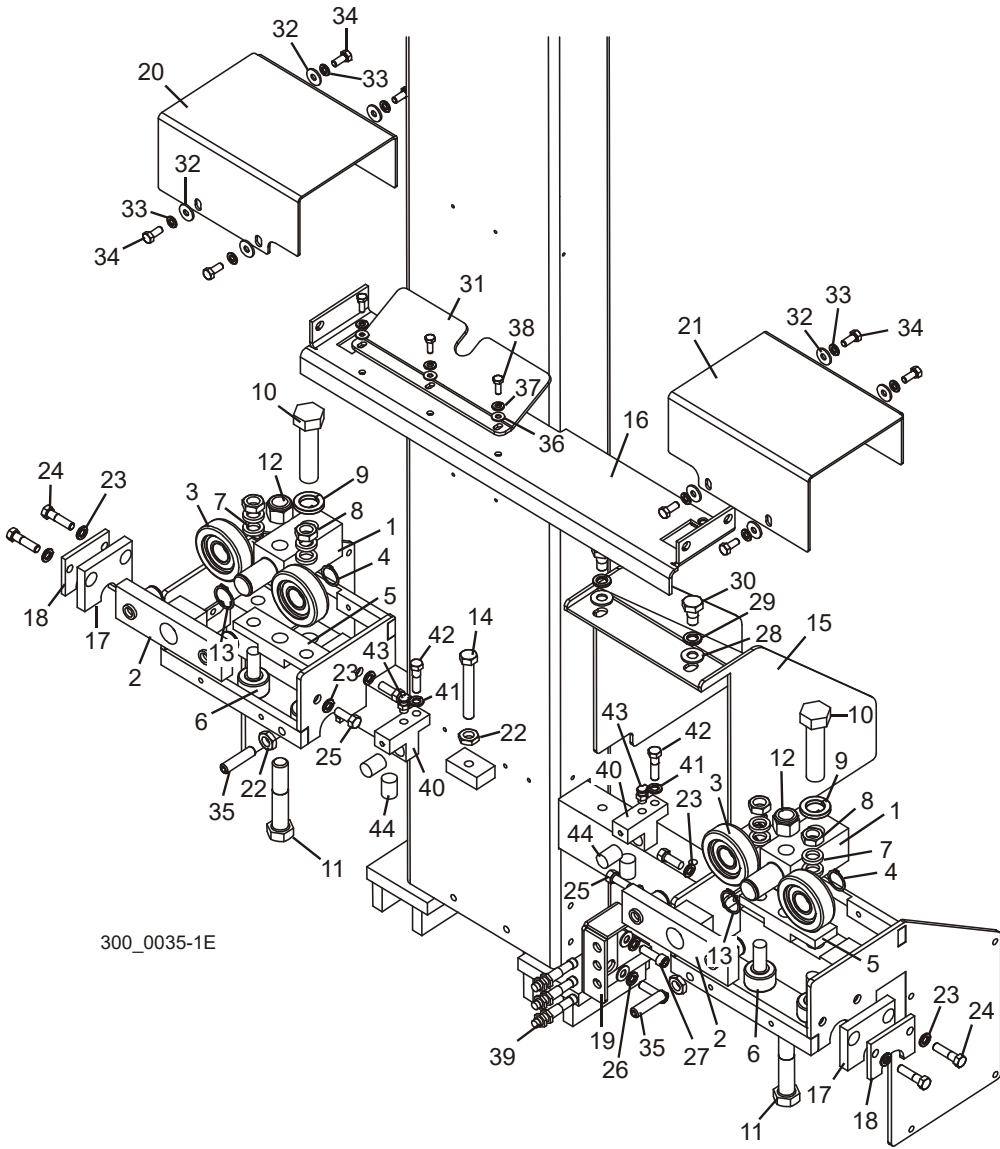

REF	DESCRIPTION (◆ Indicates Parts Available In Assemblies Only)	PART #	QTY.
	<b>BLOCK ASSEMBLY, UPPER TRACK ROLLER</b>	042506	2
1	Block, Upper Track Roller Mount	042505	1
2	Block Assembly, Upper Roller	042507	1
3	Bearing, MG305DDA	023857	2
4	Ring, 1" Outside Retaining	F04254-15	2
5	Block, Track Roller Mount	042500	1

## 6

## Power Feed

## Upper Track Rollers

6	Bearing, 1 1/2" Track Roller	012797	2	
7	Spacer, 41/64" x 1" x 3/16"	S12480	4	
8	Nut, 5/8-18 Hex Jam	F05010-11	2	
9	Washer, 7/8" Split Lock	F05011-46	1	
10	Bolt, 7/8-14 x 3 1/2" Hex Head Grade 5	F05014-1	1	
11	Bolt, 3/4-10 x 4" Hex Head Grade 5	F05013-3 <sup>1</sup>	1	
12	Nut, 3/4-10 Hex Nylon Lock	F05010-103	1	
13	Ring, 1 1/8" External Retaining Ring	F04254-36	1	
14	<b>BOLT, 1/2-13 X 3 1/2" HEX HEAD FULL THREAD</b>	F05008-11	1	
15	<b>RAMP WELDMENT, SAWDUST</b>	042379	1	
16	<b>COVER WELDMENT, UPPER TRACK ROLLER CENTER</b>	042391	1	
17	<b>PAD, PLASTIC WIPER</b>	045175	2	
18	<b>PLATE, WIPER PAD</b>	045176	2	
19	<b>BRACKET, PROXIMITY SENSOR MOUNT</b>	042112	1	
20	<b>COVER, RIGHT UPPER TRACK ROLLER</b>	042394 <sup>2</sup>	1	
21	<b>COVER, LEFT UPPER TRACK ROLLER</b>	042368 <sup>2</sup>	1	
22	<b>NUT, 1/2-13 HEX JAM</b>	F05010-31	3	
23	<b>WASHER, 3/8" SPLIT LOCK</b>	F05011-4	10	
24	<b>BOLT, 3/8-16 X 1 1/2" HEX HEAD</b>	F05007-3	4	
25	<b>BOLT, 3/8-16 X 1" HEX HEAD</b>	F05007-7	4	
26	<b>WASHER, 3/8" SAE FLAT</b>	F05011-3	2	
27	<b>BOLT, 3/8-16 X 1 1/4" SOCKET HEAD</b>	F05007-150	2	
28	<b>WASHER, 1/2" SAE FLAT</b>	F05011-2	2	
29	<b>WASHER, 1/2" SPLIT LOCK</b>	F05011-9	2	
30	<b>BOLT, 1/2-13 X 1" HEX HEAD</b>	F05008-50	2	
31	<b>PLATE, SAWDUST RAMP</b>	016801	1	
32	<b>WASHER, 5/16" STANDARD FLAT</b>	F05011-16	8	
33	<b>WASHER, 5/16" SPLIT LOCK</b>	F05011-13	8	
34	<b>BOLT, 5/16-18 X 3/4" HEX HEAD</b>	F05006-5	8	
35	<b>SCREW, 1/2-13 X 2" FLAT POINT SOCKET SET</b>	F05008-130	2	
36	<b>WASHER, 1/4" SAE FLAT</b>	F05011-11	3	
37	<b>WASHER, 1/4" SPLIT LOCK</b>	F05011-14	3	
38	<b>BOLT, 1/4-20 X 3/4" HEX HEAD</b>	F05005-129	3	
39	<b>SENSOR, 12MM PROXIMITY</b>	025041	3	
40	<b>BLOCK, UPPER TRACK OILER</b>	045045	2	
41	<b>WASHER, 3/8" SPLIT LOCK</b>	F05011-4	2	
42	<b>BOLT, 3/8-16 X 1 1/2" HEX HEAD</b>	F05007-3	2	
43	<b>FITTING, 1/8" NPT OIL W/COVER</b>	036333 <sup>3</sup>	2	
44	<b>PAD, ROUND FELT WIPER</b>	033375	4	

<sup>1</sup> Bolt reoriented so head is at bottom of assembly to eliminate interference with 2002 bedX connection hardware (1/02).

<sup>2</sup> Covers modified to fit inside of roller housings to prevent catching on boards (Rev. A6.00).

<sup>3</sup> Oil Fitting 036333 replaces track oiler system provided prior to Rev. A5.01. [See Section 6.6](#) for track oiler parts.

6.2 Lower Track Rollers

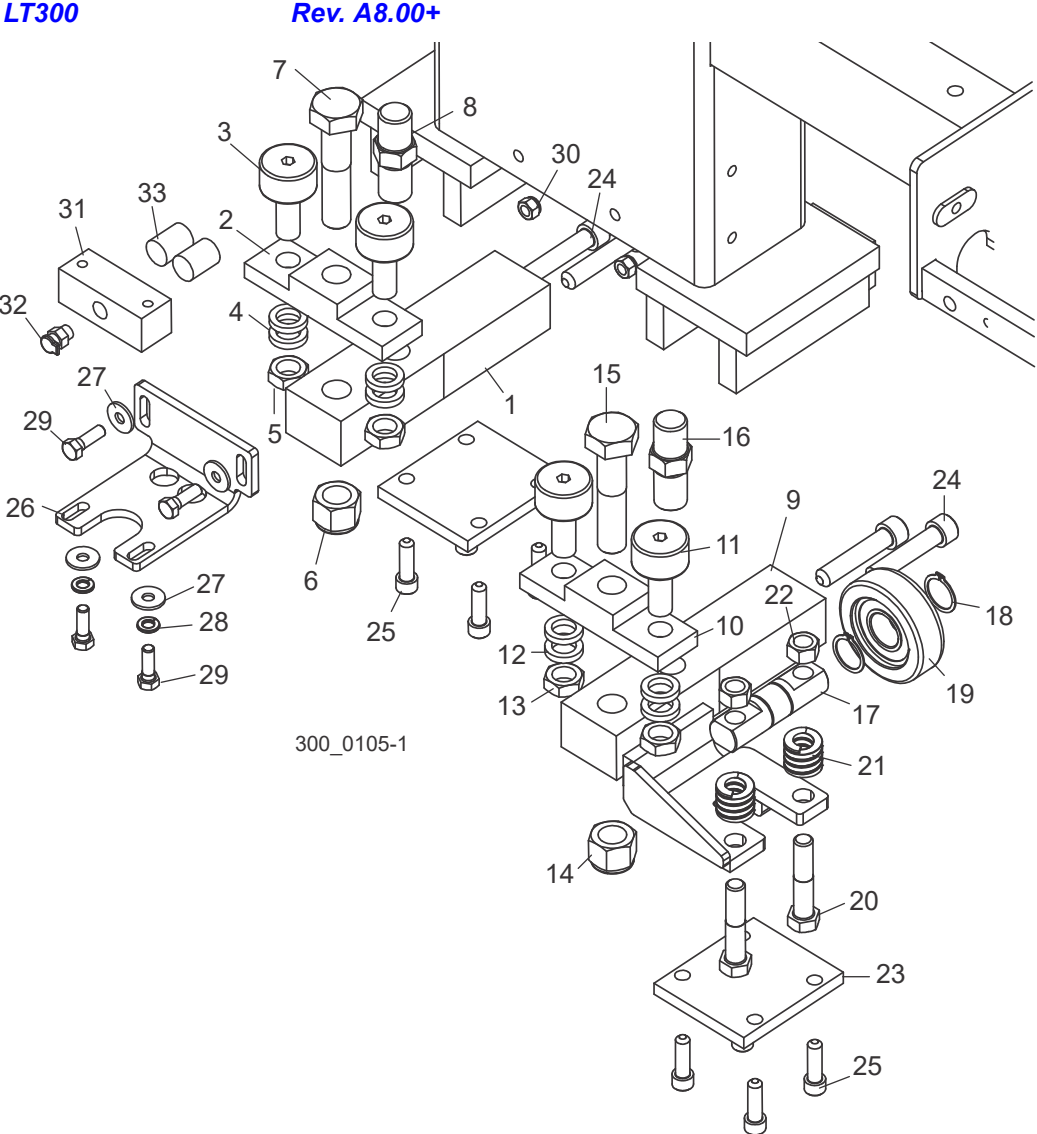

REF	DESCRIPTION (◆ Indicates Parts Available In Assemblies Only)	PART #	QTY.
	<b>BLOCK ASSEMBLY, LOWER TRACK ROLLER</b>	036345	1
1	Block Weldment, Lower Track Roller Mount	036326	1
2	Block, Track Roller Mount	042500	1
3	Bearing, 1 1/2" Track Roller	012797	2
4	Spacer, 41/64" x 1" x 3/16"	S12480	4
5	Nut, 5/8-18 Hex Jam	F05010-11	2
6	Nut, 3/4-10 Hex Nylon Lock	F05010-103	1
7	Bolt, 3/4-10 x 3 1/2" Hex Head	F05009-54	1
8	Pin, Head Safety Lock (Threaded)	036324	1

## 6

**Power Feed***Lower Track Rollers*

	<b>BLOCK ASSEMBLY, LOWER TRACK ROLLER W/BOTTOM ROLLER</b>	036701 <sup>1</sup>	1	
9	Block Weldment, Lower Track Roller Mount w/Bottom Roller	036700	1	
10	Block, Track Roller Mount	042500	1	
11	Bearing, 1 1/2" Track Roller	012797	2	
12	Spacer, 41/64" x 1" x 3/16"	S12480	4	
13	Nut, 5/8-18 Hex Jam	F05010-11	2	
14	Nut, 3/4-10 Hex Nylon Lock	F05010-103	1	
15	Bolt, 3/4-10 x 3 1/2" Hex Head	F05009-54	1	
16	Pin, Head Safety Lock (Threaded)	036324	1	
17	Shaft, Bottom Roller Mount	023858	1	
18	Ring, 1" Outside Retaining	F04254-15	2	
19	Bearing, MG305DDA	023857	1	
20	Bolt, 1/2-13 x 2 1/2" Hex Head Grade 5	F05008-74	2	
21	Spring, 1/2" ID x 1" OD x 1" Die	036713	2	
22	Nut, 1/2-13 Hex Lock	F05010-3	2	
23	<b>PLATE, LOWER ROLLER RETAINER</b>	045158	2	
24	<b>BOLT, 1/2-20 X 2 1/2" SOCKET HEAD</b>	F05008-45	4	
25	<b>BOLT, 3/8-16 X 1 1/4" SOCKET HEAD</b>	F05007-150	8	
26	<b>PLATE, LOWER TRACK OILER MOUNT</b>	042415	1	
27	<b>WASHER, 5/16" STANDARD FLAT</b>	F05011-16	4	
28	<b>WASHER, 5/16" SPLIT LOCK</b>	F05011-13	2	
29	<b>BOLT, 5/16-18 X 1" HEX HEAD</b>	F05006-1	4	
30	<b>NUT, 5/16-18 HEX NYLON LOCK</b>	F05010-58	2	
31	<b>BLOCK, LOWER TRACK OILER</b>	036334	1	
32	<b>FITTING, 1/8" NPT OIL W/COVER</b>	036333	1	
33	<b>PAD, ROUND FELT WIPER</b>	033375	2	

<sup>1</sup> 036701 Lower Roller Assembly with Bottom Roller replaces one 036375 Lower Roller Assembly (Rev. A8.00). Additional bottom roller prevents saw carriage from bouncing when changing feed directions.

### 6.3 Lower Track Rollers

LT300

Rev. A6.00 - A7.02

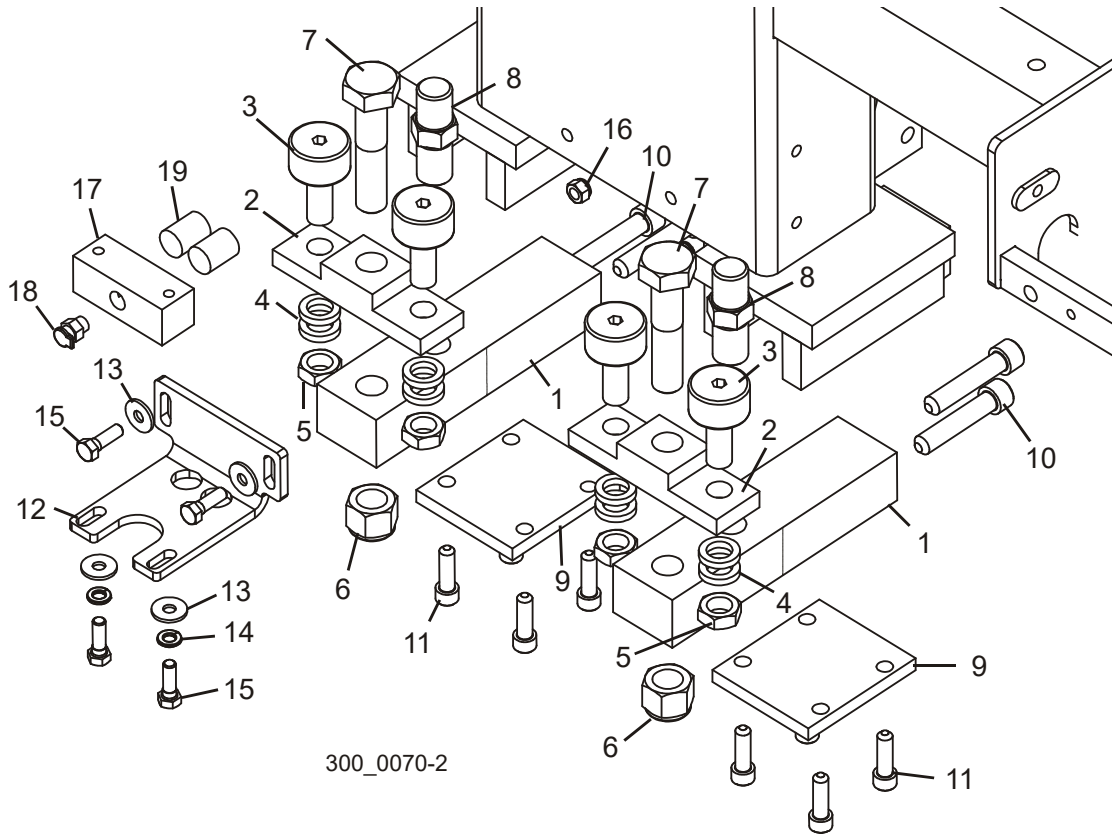

REF	DESCRIPTION (◆ Indicates Parts Available In Assemblies Only)	PART #	QTY.
	<b>BLOCK ASSEMBLY, LOWER TRACK ROLLER</b>	036345	2
1	Block, Lower Track Roller Mount	036326	1
2	Block, Track Roller Mount	042500	1
3	Bearing, 1 1/2" Track Roller	012797	2
4	Spacer, 41/64" x 1" x 3/16"	S12480	4
5	Nut, 5/8-18 Hex Jam	F05010-11	2
6	Nut, 3/4-10 Hex Nylon Lock	F05010-103	1
7	Bolt, 3/4-10 x 3 1/2" Hex Head	F05009-54	1
8	Pin, Head Safety Lock (Threaded)	036324	1
9	<b>PLATE, LOWER ROLLER RETAINER</b>	045158	2
10	<b>BOLT, 1/2-20 X 2 1/2" SOCKET HEAD</b>	F05008-45	4
11	<b>BOLT, 3/8-16 X 1 1/4" SOCKET HEAD</b>	F05007-150	8
12	<b>PLATE, LOWER TRACK OILER MOUNT</b>	042415	1
13	<b>WASHER, 5/16" STANDARD FLAT</b>	F05011-16	4
14	<b>WASHER, 5/16" SPLIT LOCK</b>	F05011-13	2

**6****Power Feed***Lower Track Rollers*

---

15	BOLT, 5/16-18 X 1" HEX HEAD	F05006-1	4	
16	NUT, 5/16-18 HEX NYLON LOCK	F05010-58	2	
17	BLOCK, LOWER TRACK OILER	036334	1	
18	FITTING, 1/8" NPT OIL W/COVER	036333	1	
19	PAD, ROUND FELT WIPER	033375	2	

## 6.4 Lower Track Rollers

LT300

Rev. A1.00 - A5.01

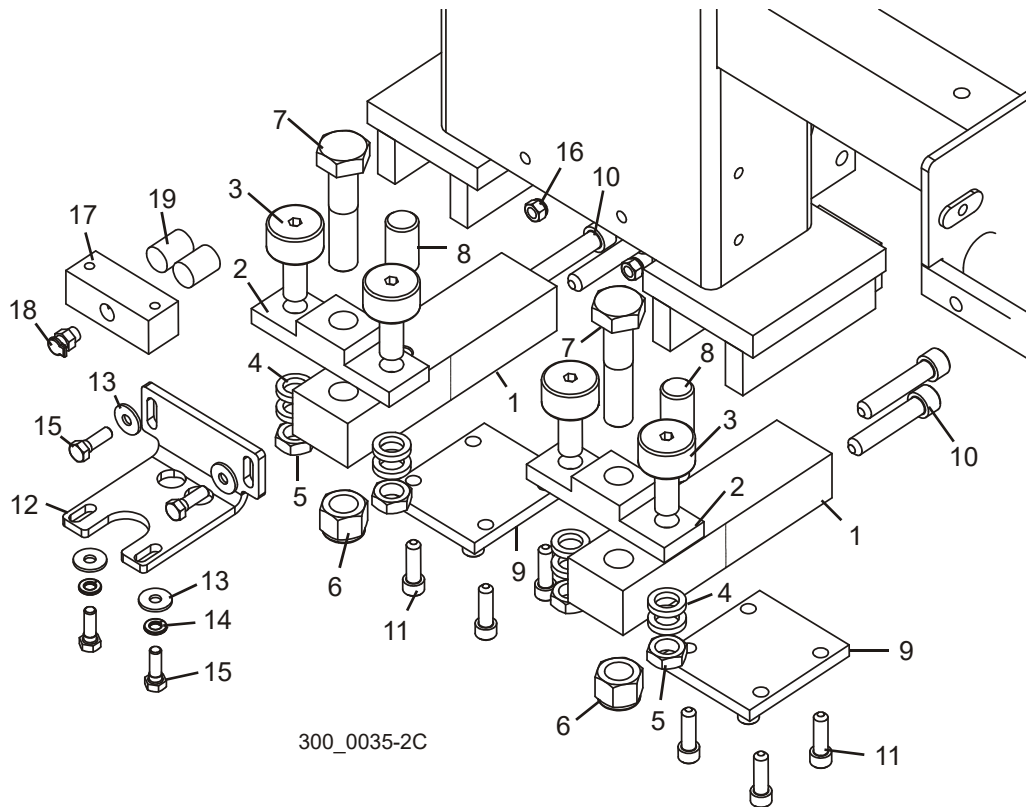

REF	DESCRIPTION (◆ Indicates Parts Available In Assemblies Only)	PART #	QTY.	
	<b>BLOCK ASSEMBLY, LOWER TRACK ROLLER</b>	042515 <sup>1</sup>	2	◆
1	Block, Lower Track Roller Mount	042514	1	
2	Block, Track Roller Mount	042500	1	
3	Bearing, 1 1/2" Track Roller	012797	2	
4	Spacer, 41/64" x 1" x 3/16"	S12480	4	
5	Nut, 5/8-18 Hex Jam	F05010-11	2	
6	Nut, 3/4-10 Hex Nylon Lock	F05010-103	1	
7	Bolt, 3/4-10 x 3 1/2" Hex Head	F05009-54	1	
8	Pin, Head Safety Lock	042516	1	
9	<b>PLATE, LOWER ROLLER RETAINER</b>	045158	2	
10	<b>BOLT, 1/2-20 X 2 1/2" SOCKET HEAD</b>	F05008-45	4	
11	<b>BOLT, 3/8-16 X 1 1/4" SOCKET HEAD</b>	F05007-150	8	
12	<b>PLATE, LOWER TRACK OILER MOUNT</b>	042415	1	
13	<b>WASHER, 5/16" STANDARD FLAT</b>	F05011-16	4	
14	<b>WASHER, 5/16" SPLIT LOCK</b>	F05011-13	2	

**6****Power Feed***Lower Track Rollers*

---

15	<b>BOLT, 5/16-18 X 1" HEX HEAD</b>	F05006-1	4	
16	<b>NUT, 5/16-18 HEX NYLON LOCK</b>	F05010-58	2	
17	<b>BLOCK, LOWER TRACK OILER</b>	036334 <sup>2</sup>	1	
18	<b>FITTING, 1/8" NPT OIL W/COVER</b>	036333 <sup>2</sup>	1	
19	<b>PAD, ROUND FELT WIPER</b>	033375	2	

<sup>1</sup> Roller Assembly 042515 obsolete. Service with component parts or replace with Roller Assembly 036345 with threaded safety lock pins ([See Section 6.3](#)).

<sup>2</sup> Oiler Block 036334 with Oil Fitting 036333 replaces track oiler system provided prior to Rev. A5.01. [See Section 6.6](#) for track oiler parts.



## 6.5 Power Feed Drive

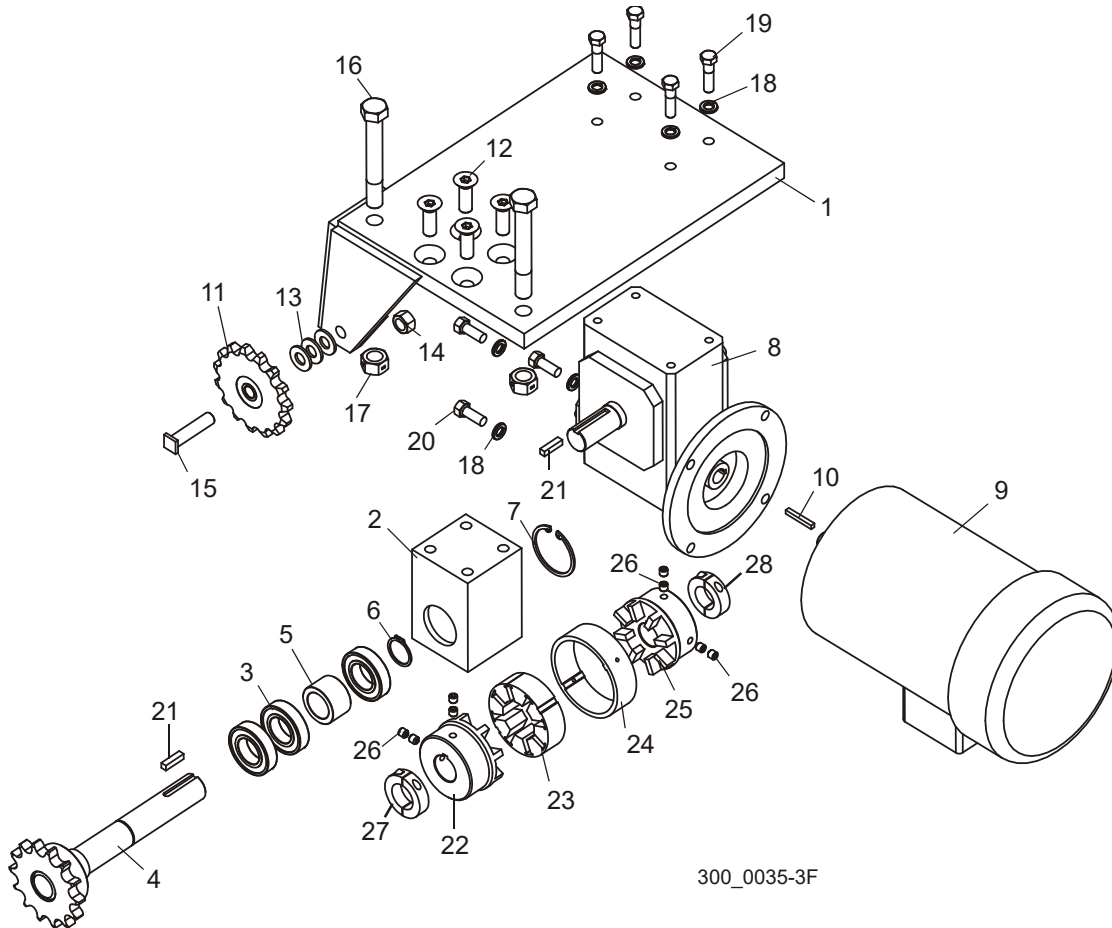

REF	DESCRIPTION (◆ Indicates Parts Available In Assemblies Only)	PART #	QTY.
	<b>DRIVE ASSEMBLY, POWER FEED</b>	042382 <sup>1</sup>	1
1	Bracket Weldment, Power Feed Drive Mount	042384 <sup>2</sup>	1
	Shaft Assembly, Power Feed Drive	042383 <sup>1</sup>	1
2	Block, Power Feed Drive Shaft Bearing	042381 <sup>1</sup>	1
3	Bearing, R18	066798 <sup>1</sup>	3
4	Shaft Weldment, Power Feed Drive	042365 <sup>1</sup>	1
5	Spacer, Power Feed Bearing	042387 <sup>1</sup>	1
6	Ring, 1 1/8" Outside Retaining	F04254-36 <sup>1</sup>	1
7	Ring, 2 1/8" Inside Retaining	F04254-38 <sup>1</sup>	1
8	Gearbox, WM3500 P/F IUC60-7.5:1-L-140TC	079195	1
9	Motor, 2HP 3P 230/460 145TC Premium Efficiency	079196	1
10	Key, 3/16" Square x 1 3/4" Long	074129	1
11	Sprocket, 6015 x 1/2" Idler	042367	1

## 6

## Power Feed

### Power Feed Drive

12	Screw, 1/2-13 x 1 1/2" Flat Socket Head	F05008-80	4	
13	Washer, 1/2" SAE Flat	F05011-2 <sup>2</sup>	3	
14	Nut, 1/2-13 Hex Lock	F05010-3 <sup>2</sup>	1	
15	Shaft, Power Feed Idler Sprocket	016828	1	
16	Bolt, 5/8-11 x 4 1/2" Hex Head Grade 5	F05009-10	2	
17	Nut, 5/8-11 Hex Lock	F05010-4	2	
18	Washer, 3/8" Split Lock	F05011-4	8	
19	Bolt, 3/8-16 x 1 1/2" Hex Head	F05007-3	4	
20	Bolt, 3/8-16 x 1" Hex Head	F05007-7	4	
21	Key, 1/4" x 1"	S21486	2	
	Coupling, Power Feed Shaft	042655 <sup>1</sup>	1	
22	Coupling Body, 10R x 1 1/8"	042655-4	1	
23	Coupling Spider, 10R Urethane	042655-2 <sup>3</sup>	1	
24	Coupling Ring, 10R Steel	042655-5	1	
25	Coupling Body, 10R x 1"	042655-1	1	
26	Screw, M8-1.25 x 8mm Socket Head Set	F05004-234 <sup>4</sup>	8	
27	Collar, 1 1/8" Shaft Clamp-On	038445 <sup>5</sup>	1	
28	Collar, 1" Shaft Clamp-On	038444 <sup>5</sup>	1	
	Oil, 8 Oz. Mobil SHC634 Bottled Synthetic Gear	L04869-4	1 <sup>6</sup>	

<sup>1</sup> Drive Assembly 042382 includes revised Drive Shaft Assembly 042383 and Coupling 042655 (Rev. A3.00). Parts revised to accommodate 1 1/8" drive shaft. Bearing Block 042381, Shaft Weldment 042365 & Spacer 042387 revised. R18 Bearings 034380 replace R16 Bearings 042360. 1 1/8" Outside Ring F04254-36 replaces 1" Outside Ring F04254-15. 2 1/8" Inside Ring F04254-38 replaces 2" Inside Ring F04254-35. Coupling 042655 revised from 1" to 1 1/8". Upgrade for revisions prior to A3.00 requires shaft assembly 042383 and coupling assembly 042655.

<sup>2</sup> Bracket modified with thicker sprocket mount and gusset to improve durability (Rev. A7.02). One F05011-2 washer removed and Nylon Lock Nut F05010-8 replaced with swaged Lock Nut F05010-3 to accommodate thicker bracket. Retrofit of Power Feed Bracket requires notched Sawdust Ramp 016081 ([See Section 6.1](#)).

<sup>3</sup> If replacing coupler spider on LT300 prior to Rev. A9.01, also add shaft collars (Items 26 & 27) to hold coupler in position and reduce wear.

<sup>4</sup> Two set screws used at each location. Second set screw locks first set screw in place. F05004-234 Replaces F05004-189 used prior to Rev. B2.00 due to change in set screw holes in coupler by vendor.

<sup>5</sup> Clamping collars 038445 and 038444 added Rev. A9.01 to hold coupling in position.

<sup>6</sup> 19 - 22 oz. required for complete oil replacement.

## 6.6 Track Oiler System

LT300

Rev. A1.00 - A5.00<sup>1</sup>

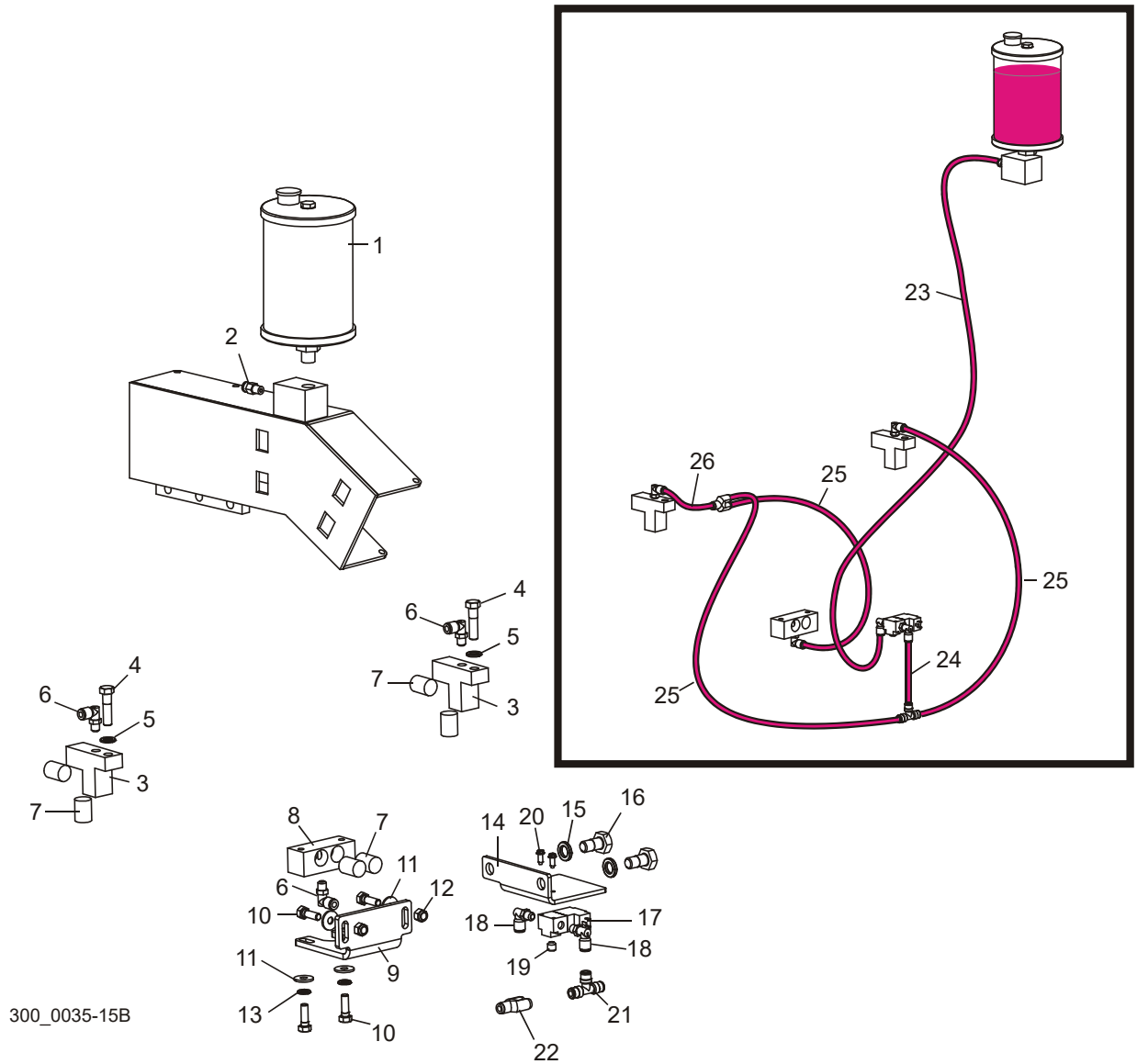

REF	DESCRIPTION (◆ Indicates Parts Available In Assemblies Only)	PART #	QTY.
1	TANK, LT300 OILER RESERVOIR	042740 <sup>1</sup>	1
2	FITTING, 1/8" NPT X 1/4" TUBE	F03078	1
3	BLOCK, UPPER TRACK OILER	045045	2
4	BOLT, 3/8-16 X 1 1/2" HEX HEAD	F05007-3	2
5	WASHER, 3/8" SPLIT LOCK	F05011-4	2

<sup>1</sup> Track oiler system removed to reduce cost (Rev. A5.01). [See Section 6.3](#) for manual track oiler parts.

## 6

## Power Feed

### Track Oiler System

6	<b>FITTING, 1/8" MPT X 1/4" TUBE 90° SWIVEL ELBOW</b>	P09736	3	
7	<b>PAD, ROUND FELT WIPER</b>	033375	6	
8	<b>BLOCK, LOWER TRACK OILER</b>	042414	1	
9	<b>PLATE, LOWER TRACK OILER MOUNT</b>	042415	1	
10	<b>BOLT, 5/16-18 X 1" HEX HEAD</b>	F05006-1	4	
11	<b>WASHER, 5/16" STANDARD FLAT</b>	F05011-16	4	
12	<b>NUT, 5/16-18 HEX NYLON LOCK</b>	F05010-58	2	
13	<b>WASHER, 5/16" SPLIT LOCK</b>	F05011-13	2	
	<b>VALVE ASSEMBLY, OILER</b>	042738 <sup>1</sup>	1	
14	Plate, Oiler Valve Mount	042737	1	
15	Washer, 1/2" Split Lock	F05011-9	2	
16	Bolt, 1/2-13 x 1" Hex Head	F05008-50	2	
17	Valve, Oiler	042739	1	
18	Fitting, 1/8" MPT x 1/4" Tube 90° Swivel Elbow	P09736	2	
19	Fitting, 1/8" NPT Socket Pipe Plug	P30127	1	
20	Screw, #8-32 x 1/2" Slotted Hex Head	F05015-18	2	
21	Fitting, 1/4" Tube Tee	P21544	1	
22	Fitting, 1/4" Tube Y	042546	1	
23	<b>TUBING, 1/4"</b>	R01869	16 ft.	
24	<b>TUBING, 1/4"</b>	R01869	.5 ft.	
25	<b>TUBING, 1/4"</b>	R01869	6 ft.	
26	<b>TUBING, 1/4"</b>	R01869	.125 ft.	

<sup>1</sup> Reservoir 042740 and oiler valve assembly 042738 replace 050015 to improve oil capacity, flow and distribution (Rev. A3.00). Use kit 017786 to retrofit previous revisions.

## 6.7 Feed Chain & Stops

LT300

Rev. A7.00+

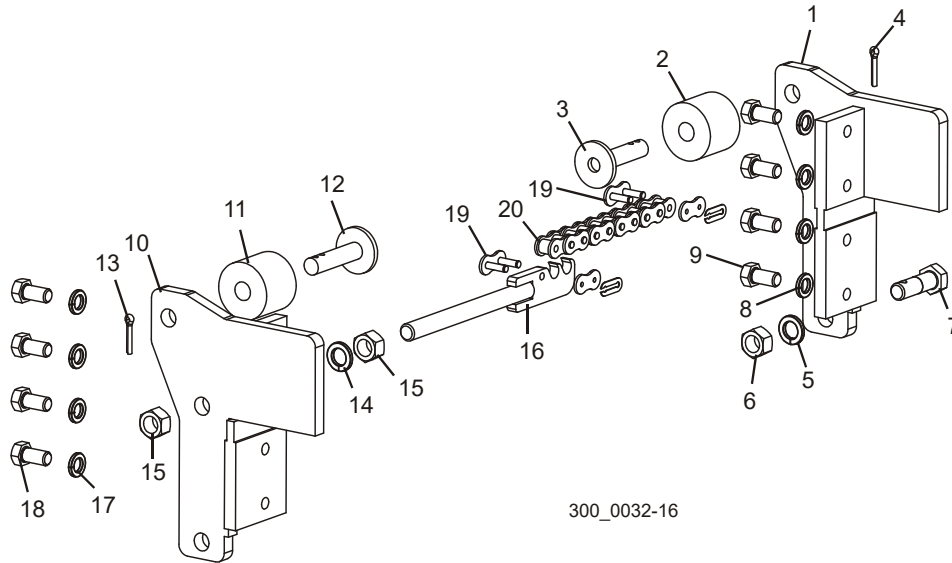

REF	DESCRIPTION (◆ Indicates Parts Available In Assemblies Only)	PART #	QTY.
	<b>STOP ASSEMBLY, FRONT SAW HEAD</b>	035646	1
1	Bracket Weldment, Front Saw Head Stop	042408	1
2	Bushing, 11/16" x 2 1/8" x 1 3/4" Rubber	P12165	1
3	Pin Weldment, Head Stop	W09293	1
4	Pin, 3/16" x 1" Cotter	F05012-21	1
5	Washer, 5/8" Split Lock	F05011-27	1
6	Nut, 5/8-18 Hex	F05010-50	1
7	Bolt, #60 Feed Chain Tensioner	035653	1
8	Washer, 1/2" Split Lock	F05011-9	4
9	Bolt, 1/2-13 x 1 Hex Head Grade 8	F05008-128	4
	<b>STOP ASSEMBLY, REAR HEAD</b>	036199	1
10	Stop Weldment, Right	042411	1
11	Bushing, 11/16" x 2 1/8" x 1 3/4" Rubber	P12165	1
12	Pin Weldment, Head Stop	W09293	1
13	Pin, 3/16" x 1" Cotter	F05012-21	1
14	Washer, 5/8" Split Lock	F05011-27	1
15	Nut, 5/8-18 Hex	F05010-50	2
16	Rod Weldment, #60 Feed Chain Tensioner	035652	1
17	Washer, 1/2" Split Lock	F05011-9	4
18	Bolt, 1/2-13 x 1 Hex Head Grade 8	F05008-128	4
19	Link, #60 Master	042398	2
20	Chain, #60 x 27' Power Feed	036200	1

## 6.8 Feed Chain & Stops

LT300

Rev. A5.00 - A6.01

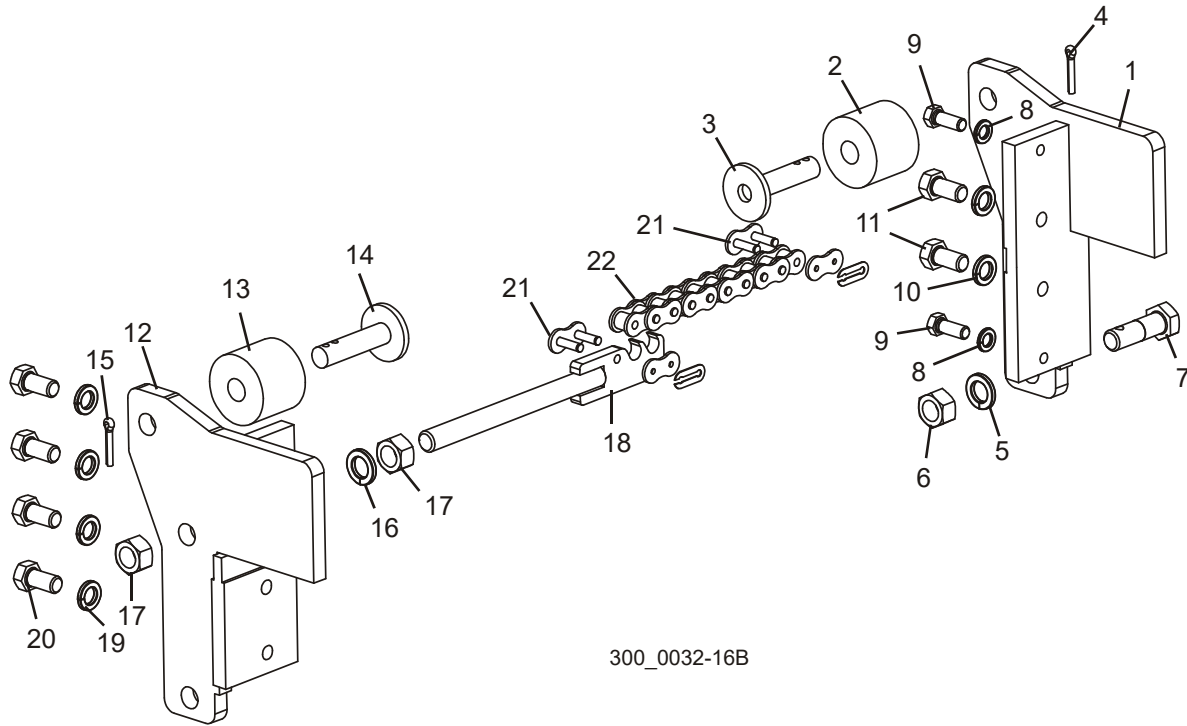

REF	DESCRIPTION (◆ Indicates Parts Available In Assemblies Only)	PART #	QTY.
	<b>STOP ASSEMBLY, FRONT HEAD</b>	036150	1
1	Stop Weldment, Left	036151	1
2	Bushing, 11/16" x 2 1/8" x 1 3/4" Rubber	P12165	1
3	Pin Weldment, Head Stop	W09293	1
4	Pin, 3/16" x 1" Cotter	F05012-21	1
5	Washer, 5/8" Split Lock	F05011-27	1
6	Nut, 5/8-18 Hex	F05010-50	1
7	Bolt, #60 Feed Chain Tensioner	035653	1
8	Washer, 3/8 Split Lock	F05011-4	2
9	Bolt, 3/8-16x1 Hex Head Grade 8	F05007-82	2
10	Washer, 1/2" Split Lock	F05011-9	2
11	Bolt, 1/2-13 x 1 Hex Head Grade 8	F05008-128	2
	<b>STOP ASSEMBLY, REAR HEAD</b>	036199	1
12	Stop Weldment, Right	042411	1
13	Bushing, 11/16" x 2 1/8" x 1 3/4" Rubber	P12165	1
14	Pin Weldment, Head Stop	W09293	1
15	Pin, 3/16" x 1" Cotter	F05012-21	1
16	Washer, 5/8" Split Lock	F05011-27	1

<b>17</b>	Nut, 5/8-18 Hex	F05010-50	2	
<b>18</b>	Rod Weldment, #60 Feed Chain Tensioner	035652	1	
<b>19</b>	Washer, 1/2" Split Lock	F05011-9	4	
<b>20</b>	Bolt, 1/2-13 x 1 Hex Head Grade 8	F05008-128	4	
<b>21</b>	Link, #60 Master	042398	2	
<b>22</b>	Chain, #60 x 27' Power Feed	036200	1	

## 6.9 Feed Chain & Stops

LT300

Rev. A1.00 - A4.00

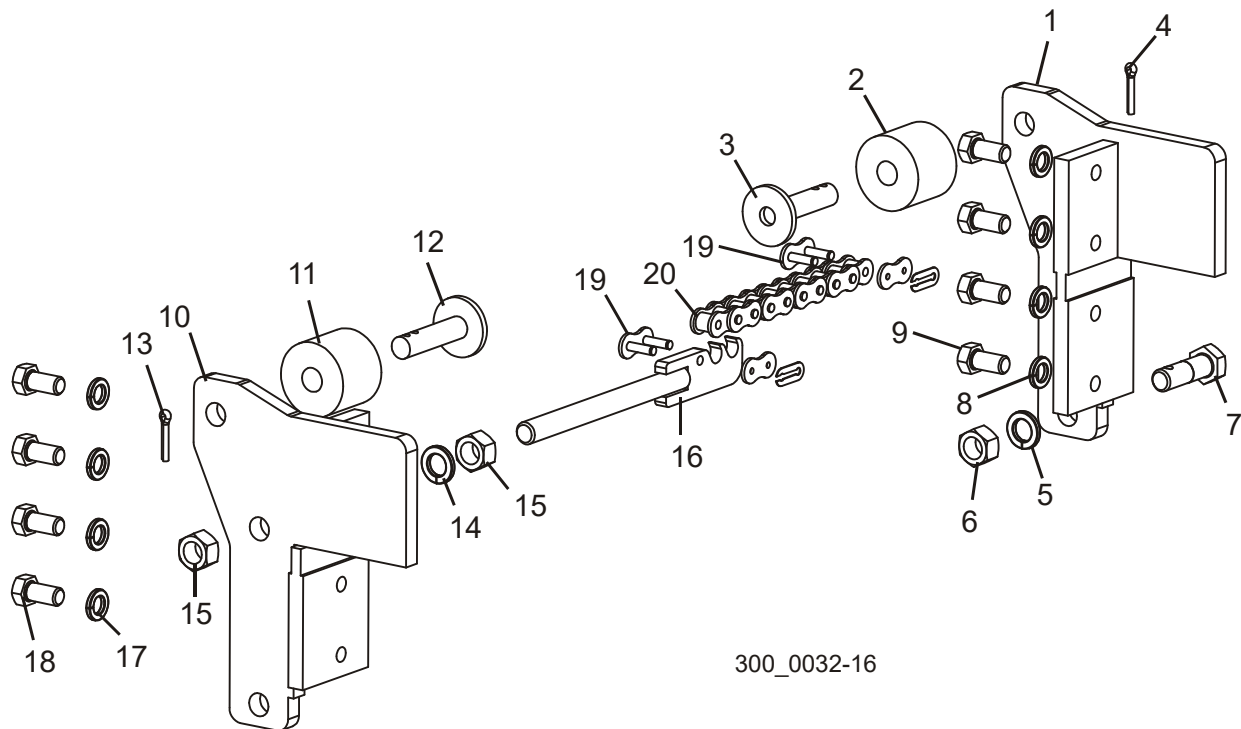

REF	DESCRIPTION (◆ Indicates Parts Available In Assemblies Only)	PART #	QTY.
	<b>STOP ASSEMBLY, FRONT SAW HEAD</b>	035646	1
1	Bracket Weldment, Front Saw Head Stop	042408	1
2	Bushing, 11/16" x 2 1/8" x 1 3/4" Rubber	P12165	1
3	Pin Weldment, Head Stop	W09293	1
4	Pin, 3/16" x 1" Cotter	F05012-21	1
5	Washer, 5/8" Split Lock	F05011-27	1
6	Nut, 5/8-18 Hex	F05010-50	1
7	Bolt, #60 Feed Chain Tensioner	035653	1
8	Washer, 1/2" Split Lock	F05011-9	4
9	Bolt, 1/2-13 x 1 Hex Head Grade 8	F05008-128	4
	<b>STOP ASSEMBLY, REAR SAW HEAD</b>	035647	1
10	Bracket Weldment, Rear Saw Head Stop	042411	1
11	Bushing, 11/16" x 2 1/8" x 1 3/4" Rubber	P12165	1
12	Pin Weldment, Head Stop	W09293	1
13	Pin, 3/16" x 1" Cotter	F05012-21	1
14	Washer, 5/8" Split Lock	F05011-27	1
15	Nut, 5/8-18 Hex	F05010-50	2



<b>16</b>	Rod Weldment, #60 Feed Chain Tensioner	035652	1	
<b>17</b>	Washer, 1/2" Split Lock	F05011-9	4	
<b>18</b>	Bolt, 1/2-13 x 1 Hex Head Grade 8	F05008-128	4	
<b>19</b>	Link, #60 Master	042398	2	
<b>20</b>	Chain, #60 Power Feed	042397	1	

## 6.10 Lower Wireway

LT300

Rev. B4.00+

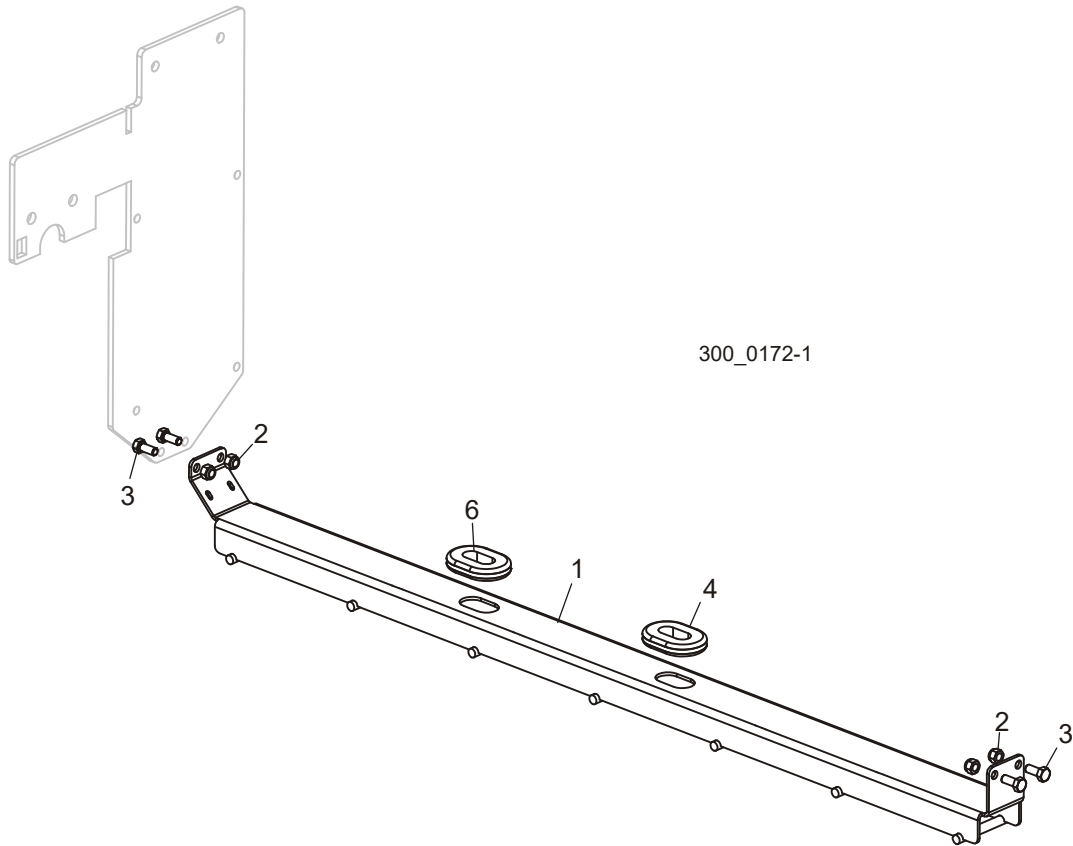

REF	DESCRIPTION (◆ Indicates Parts Available In Assemblies Only)	PART #	QTY.
1	CABLE CARRIER, LOWER	036341	1
2	NUT, 5/16-18 HEX NYLON LOCK	F05010-58	4
3	BOLT, 5/16-18 X 3/4" HEX HEAD	F05006-5	4
4	GROMMET, 1" X 1 3/4" OVAL RUBBER	085613	2

## 6.11 Lower Wireway

LT300

Rev. B2.00 - B3.02

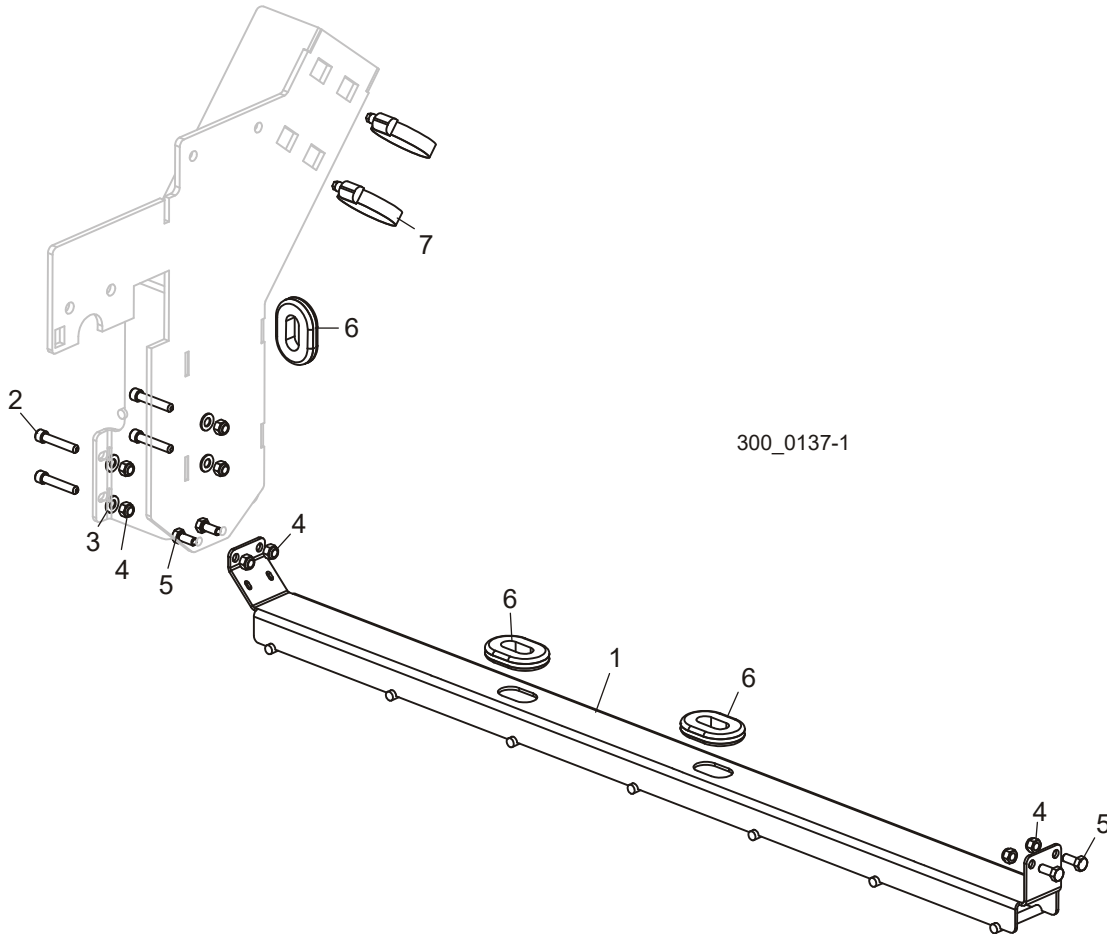

REF	DESCRIPTION (◆ Indicates Parts Available In Assemblies Only)	PART #	QTY.
1	CABLE CARRIER, LOWER	036341	1
2	BOLT, 5/16-18 X 1 3/4" SOCKET HEAD	F05006-65	4
3	WASHER, 5/16 SAE FLAT	F05011-17	4
4	NUT, 5/16-18 HEX NYLON LOCK	F05010-58	8
5	BOLT, 5/16-18 X 3/4" HEX HEAD	F05006-5	4
6	GROMMET, 1" X 1 3/4" OVAL RUBBER	085613	3
7	CLAMP, 2-1/2" WORM	P09895	2

## 6.12 Lower Wireway

LT300

Rev. A7.00 - B1.01

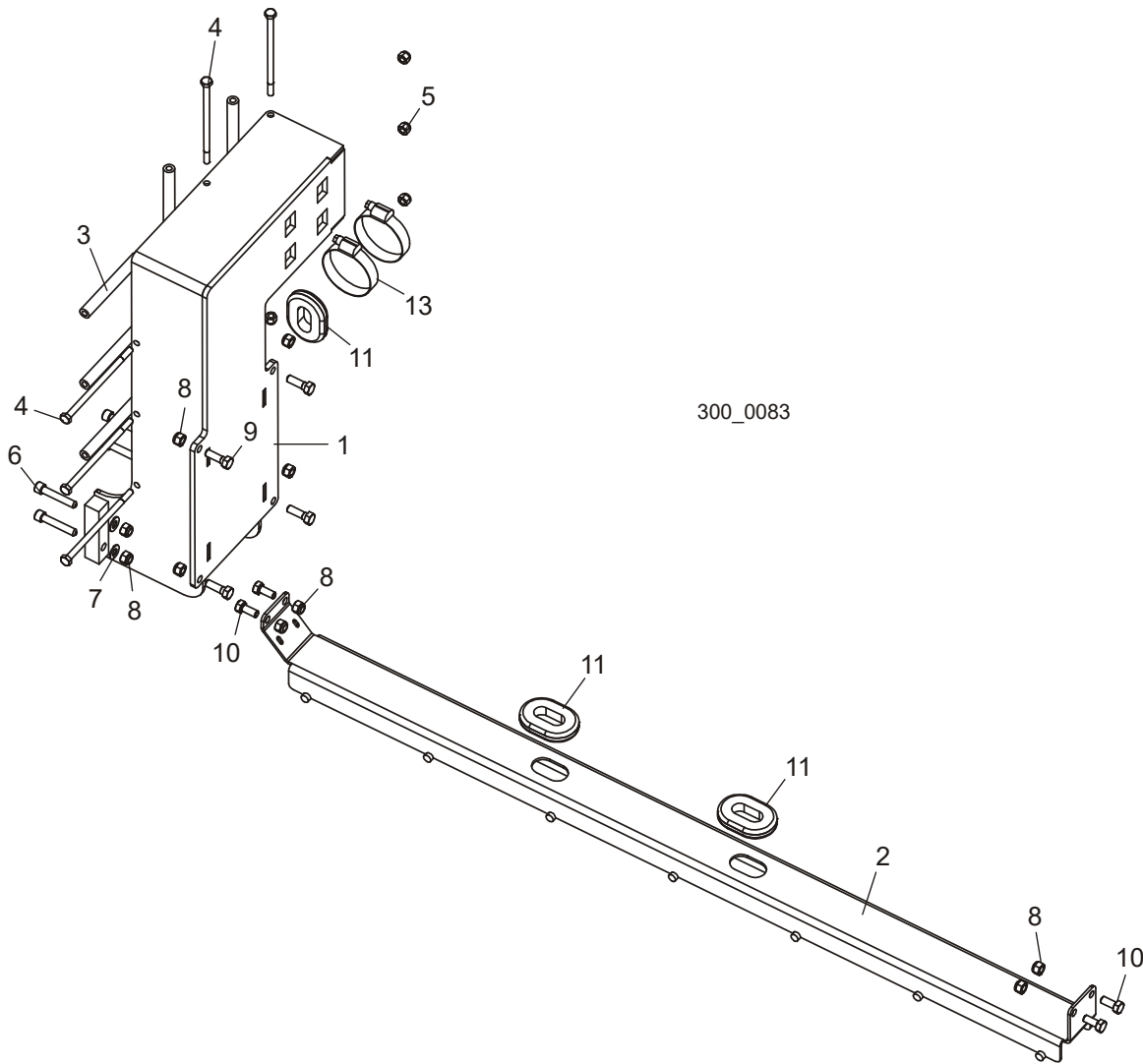

REF	DESCRIPTION (◆ Indicates Parts Available In Assemblies Only)	PART #	QTY.
	<b>CARRIER ASSEMBLY, LOWER MAST CABLE</b>	036342	1
1	Mount Weldment, Cable Carrier	036329	1
2	Cable Carrier, Lower	036341	1
3	Spacer, Wireway	042111	5

<b>4</b>	Bolt, 1/4-20 x 5" Hex Head	F05005-146	5	
<b>5</b>	Nut, 1/4-20 Hex Nylon Lock	F05010-69	5	
<b>6</b>	Bolt, 5/16-18 x 1 3/4" Socket Head	F05006-65	4	
<b>7</b>	Washer, 5/16 SAE Flat	F05011-17	4	
<b>8</b>	Nut, 5/16-18 Hex Nylon Lock	F05010-58	12	
<b>9</b>	Bolt, 5/16-18 x 1" Hex Head	F05006-1	4	
<b>10</b>	Bolt, 5/16-18 x 3/4" Hex Head	F05006-5	4	
<b>11</b>	Grommet, 1" x 1 3/4" Oval Rubber	085613	3	
<b>12</b>	Clamp, 2-1/2" Worm	P09895	2	

### 6.13 Lower Wireway

LT300

Rev. A6.00 - A6.01

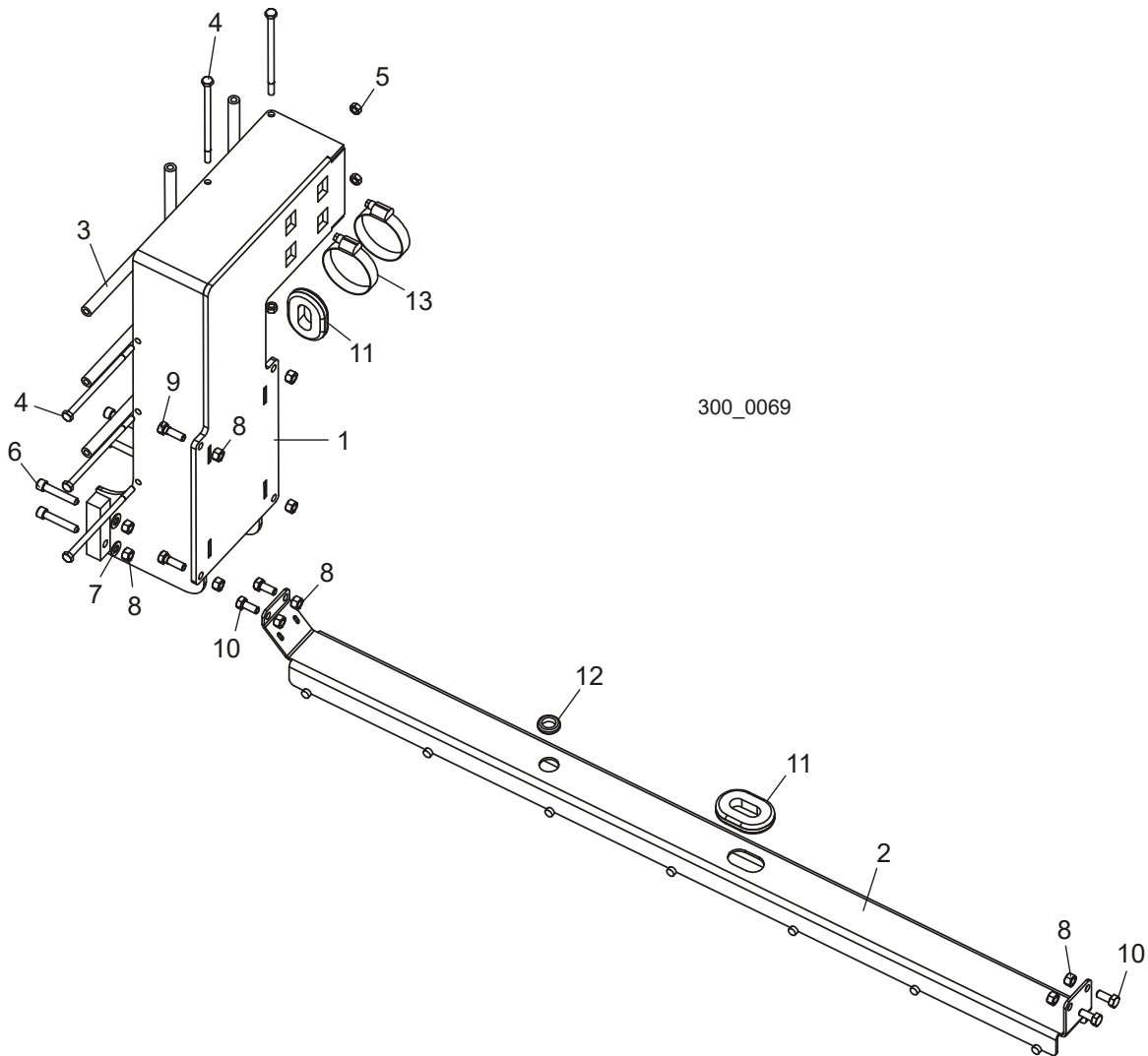

REF	DESCRIPTION (◆ Indicates Parts Available In Assemblies Only)	PART #	QTY.
	<b>CARRIER ASSEMBLY, LOWER MAST CABLE</b>	036342	1
1	Mount Weldment, Cable Carrier	036329	1
2	Cable Carrier, Lower	036341	1
3	Spacer, Wireway	042111	5

4	Bolt, 1/4-20 x 5" Hex Head	F05005-146	5	
5	Nut, 1/4-20 Hex Nylon Lock	F05010-69	5	
6	Bolt, 5/16-18 x 1 3/4" Socket Head	F05006-65	4	
7	Washer, 5/16 SAE Flat	F05011-17	4	
8	Nut, 5/16-18 Hex Nylon Lock	F05010-58	12	
9	Bolt, 5/16-18 x 1" Hex Head	F05006-1	4	
10	Bolt, 5/16-18 x 3/4" Hex Head	F05006-5	4	
11	Grommet, 1" x 1 3/4" Oval Rubber	085613	2	
12	Grommet, 5/8" ID Rubber	P11764	1	
13	Clamp, 2-1/2" Worm	P09895	2	

### 6.14 Lower Wireway

LT300

Rev. A5.00 - A5.01

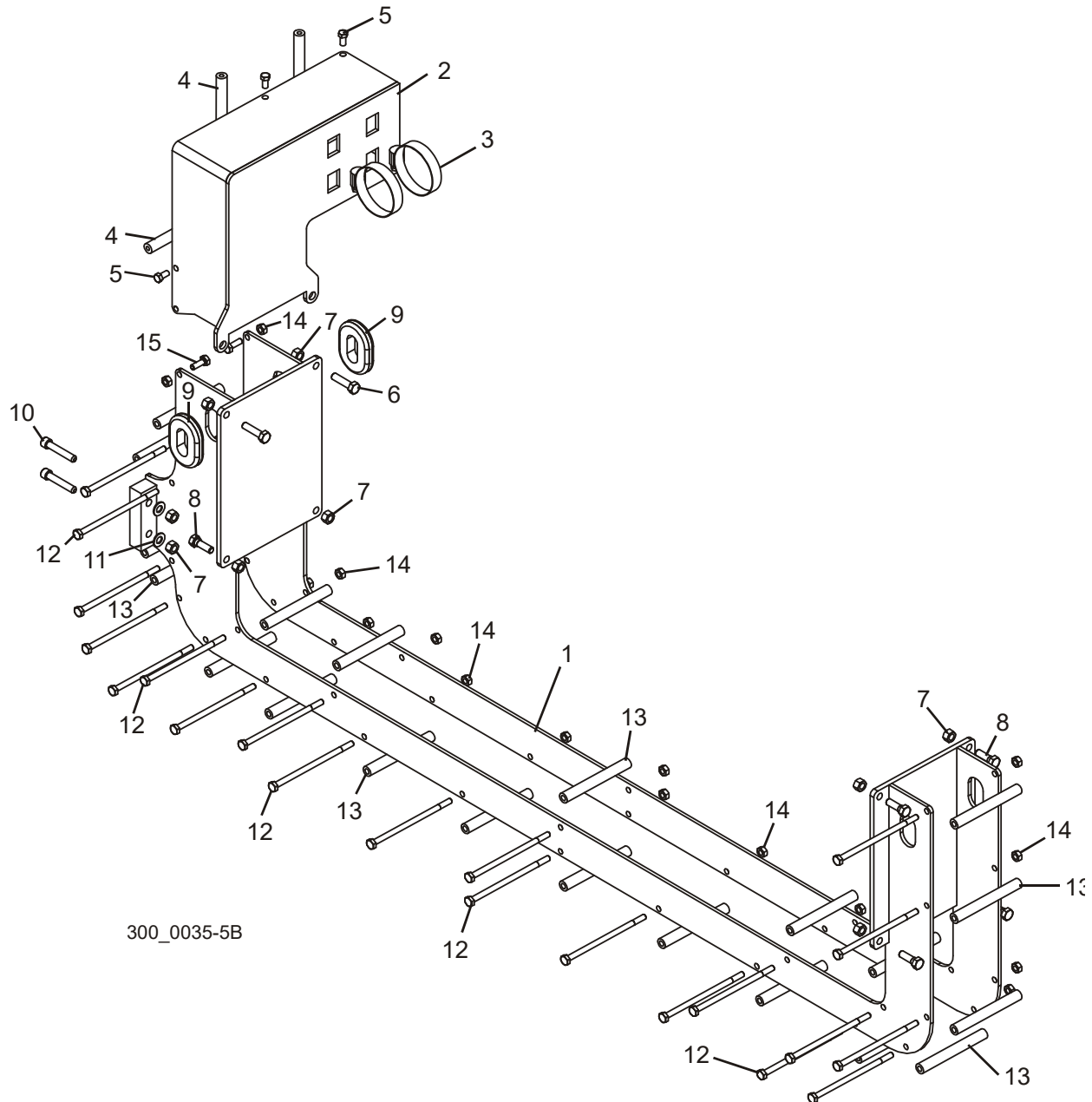

300\_0035-5B

REF	DESCRIPTION (◆ Indicates Parts Available In Assemblies Only)	PART #	QTY.
	<b>WIREWAY ASSEMBLY, LOWER MAST</b>	036144	1
1	Wireway Weldment, Lower Mast Main	036145	1
2	Wireway Weldment, Lower Mast Extension	042144	1
3	Clamp, 2-1/2" Worm	P09895	2



<b>4</b>	Spacer, Threaded Wireway	042229	3	
<b>5</b>	Bolt, 1/4-20 x 1/2" Hex Head	F05005-15	6	
<b>6</b>	Bolt, 5/16-18 x 1 1/4" Hex Head Full Thread Grade 5	F05006-93	2	
<b>7</b>	Nut, 5/16-18 Hex Lock	F05010-6	12	
<b>8</b>	Bolt, 5/16-18 x 1" Hex Head	F05006-1	6	
<b>9</b>	Grommet, 1" x 1 3/4" Oval Rubber	085613	2	
<b>10</b>	Screw, 5/16-18 x 1 3/4" Socket Head	F05006-65	4	
<b>11</b>	Washer, 5/16 SAE Flat	F05011-17	4	
<b>12</b>	Bolt, 1/4-20 x 5" Hex Head	F05005-146	20	
<b>13</b>	Spacer, Wireway	042111	20	
<b>14</b>	Nut, 1/4-20 Hex Lock	F05010-21	22	
<b>15</b>	Bolt, 1/4-20 x 3/4" Hex Head	F05005-129	2	

### 6.15 Lower Wireway

LT300

Rev. A1.00 - A4.00

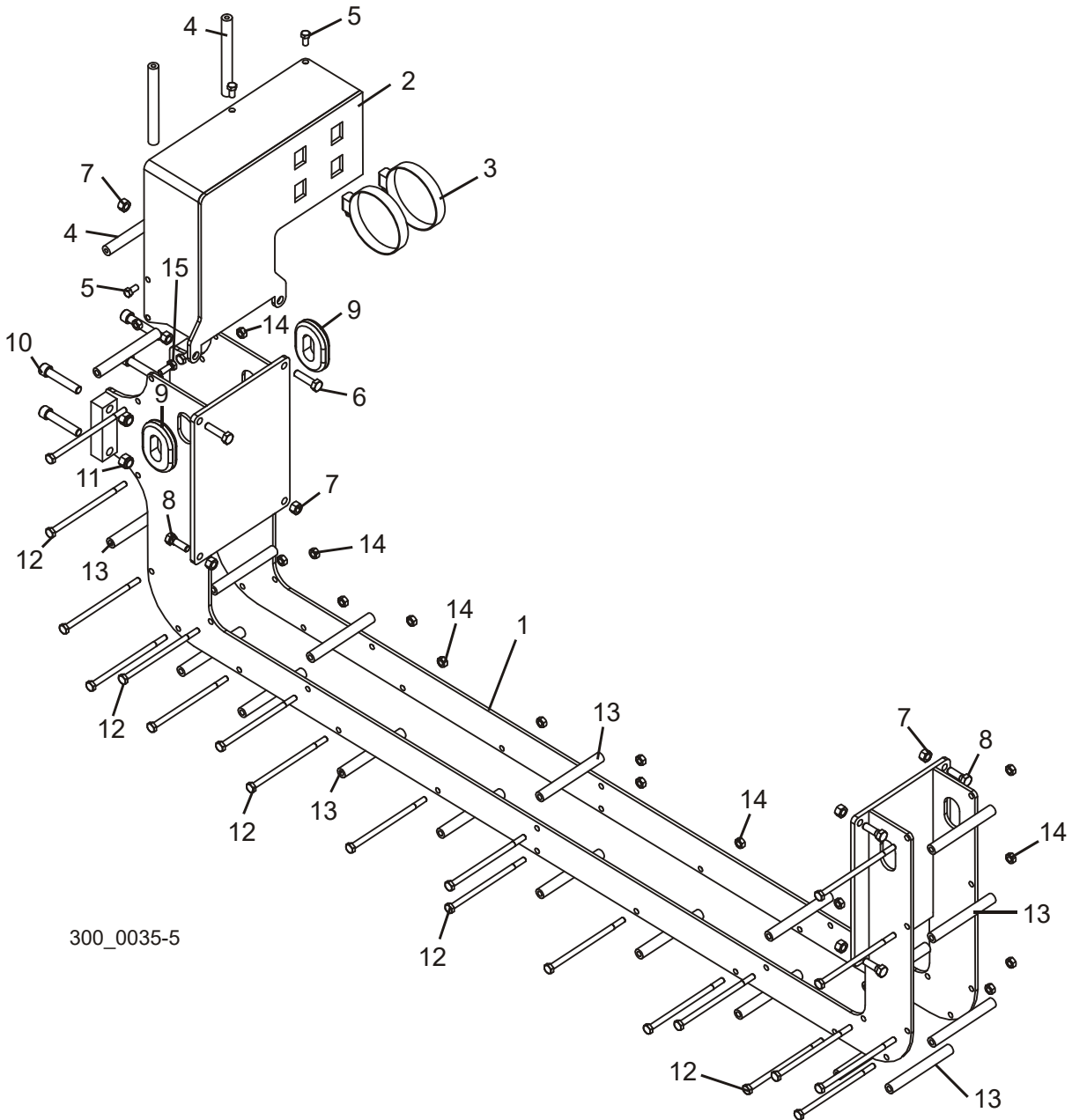

300\_0035-5

REF	DESCRIPTION (◆ Indicates Parts Available In Assemblies Only)	PART #	QTY.	
	<b>WIREWAY ASSEMBLY, LOWER MAST</b>	042240	1	◆
1	Wireway Weldment, Lower Mast Main	042110 <sup>1</sup>	1	
2	Wireway Weldment, Lower Mast Extension	042144	1	
3	Clamp, 3 3/4" Worm	P04921	2	

4	Spacer, Threaded Wireway	042229	3	
5	Bolt, 1/4-20 x 1/2" Hex Head	F05005-15	6	
6	Bolt, 5/16-18 x 1 1/4" Hex Head Full Thread Grade 5	F05006-93	2	
7	Nut, 5/16-18 Hex Lock	F05010-6	8	
8	Bolt, 5/16-18 x 1" Hex Head	F05006-1	6	
9	Grommet, 1" x 1 3/4" Oval Rubber	085613	2	
10	Bolt, 3/8-16 x 2" Socket Head	F05007-58	4	
11	Nut, 3/8-16 Hex Nylon Lock	F05010-10	4	
12	Bolt, 1/4-20 x 5" Hex Head	F05005-146	20	
13	Spacer, Wireway	042111	20	
14	Nut, 1/4-20 Hex Lock	F05010-21	22	
15	Bolt, 1/4-20 x 3/4" Hex Head	F05005-129	2	

<sup>1</sup> Wireway weldment 042110 reduced in size to increase clearance between cable carrier and up/down system.

# 7 Bed Frame

## Bed Rail #1 (Front)

### SECTION 7 BED FRAME

#### 7.1 Bed Rail #1 (Front)

LT300

Rev. A7.00+

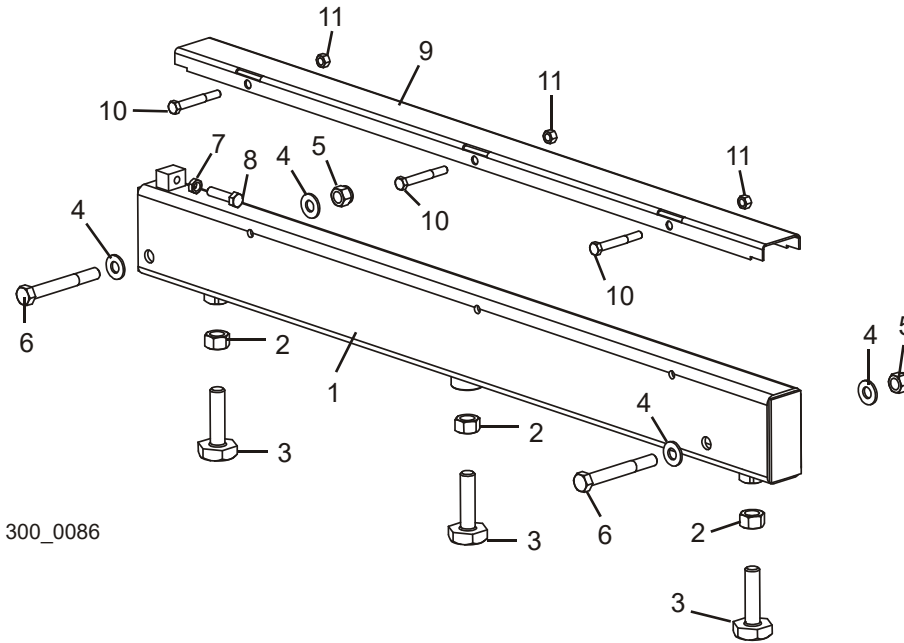

REF	DESCRIPTION (◆ Indicates Parts Available In Assemblies Only)	PART #	QTY.
	<b>RAIL ASSEMBLY, #1 BED (FRONT)</b>	036410	1
1	Rail Weldment, #1 Bed	036411	1
2	Nut, 5/8-11 Hex	F05010-5	3
3	Bolt, Bed Rail Adjustment	S13006	3
4	Washer, 1/2" SAE Flat	F05011-2	4
5	Nut, 1/2-13 Nylon Lock	F05010-8	2
6	Bolt, 1/2-13 x 4" Hex Head	F05008-26	2
7	Nut, 3/8-16 Hex Jam	F05010-29	1
8	Bolt, 3/8-16 x 1 1/2" Hex Head Full Thread	F05007-17	1
	Cover Kit, Front/Rear Bed Rail SS	079144	1
9	Cover, Stainless Steel Bed Rail	016898	1
10	Bolt, 5/16-18 x 2 1/2" Hex Head	F05006-10	3
11	Nut, 5/16-18 Hex Lock	F05010-6	3

## 7.2 Bed Rail #1

LT300

Rev. A1.00 - A6.01

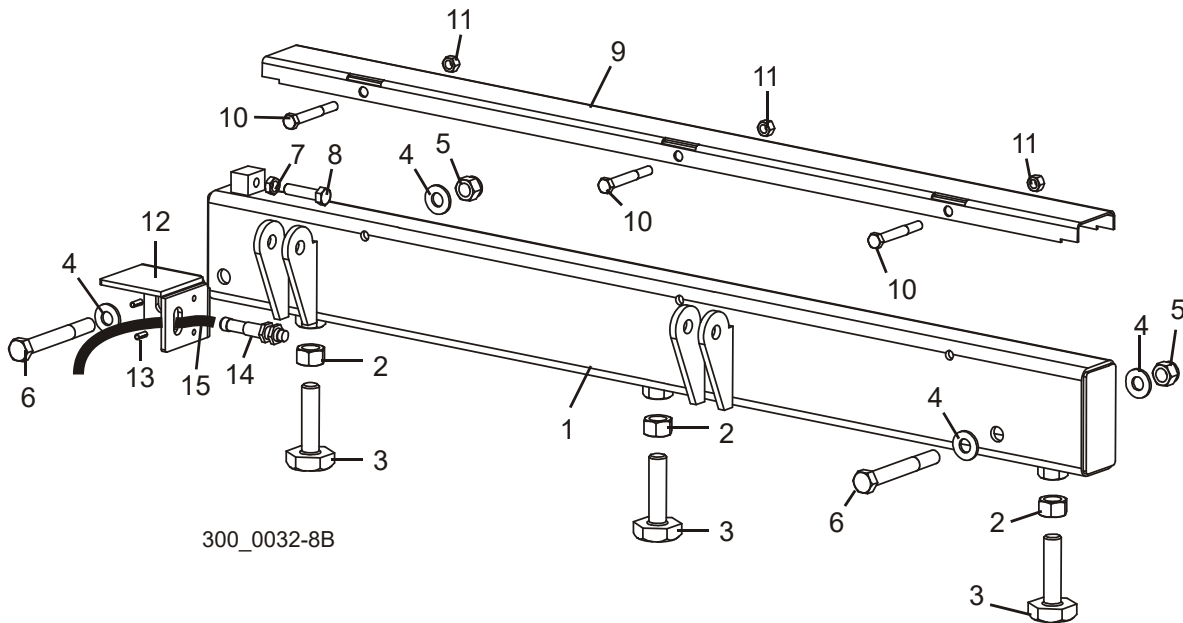

REF	DESCRIPTION (◆ Indicates Parts Available In Assemblies Only)	PART #	QTY.
	<b>RAIL ASSEMBLY, #1 BED</b>	035634 <sup>1</sup>	1
1	Rail Weldment, #1 Bed	035630 <sup>2</sup>	1
2	Nut, 5/8-11 Hex	F05010-5 <sup>3</sup>	3
3	Bolt, Bed Rail Adjustment	S13006 <sup>3</sup>	3
4	Washer, 1/2" SAE Flat	F05011-2	4
5	Nut, 1/2-13 Nylon Lock	F05010-8	2
6	Bolt, 1/2-13 x 4" Hex Head	F05008-26	2
7	Nut, 3/8-16 Hex Jam	F05010-29	1
8	Bolt, 3/8-16 x 1 1/2" Hex Head Full Thread	F05007-17	1
9	Cover, Stainless Steel Bed Rail	016898 <sup>4</sup>	1
10	Bolt, 5/16-18 x 2 1/2" Hex Head	F05006-10	3
11	Nut, 5/16-18 Hex Lock	F05010-6	3
12	Bracket, Proximity Sensor Guard	035419 <sup>1</sup>	1
13	Pin, 3/16 x 1/2" Roll	F05012-35 <sup>1</sup>	2
14	<b>SENSOR, 12MM PROXIMITY</b>	025041 <sup>1</sup>	1
15	<b>CABLE, 12MM X 7M RA PROXIMITY SENSOR</b>	025120 <sup>1</sup>	1

<sup>1</sup> Toe roller sensors and hardware removed from bed rail assembly Rev. A6.00. Toe Roller mounting hardware removed from bed rail Rev. A7.00 ([See Section 7.1](#)).

<sup>2</sup> Center adjustment nut on rail weldment replaced to make bed rail more durable (Rev. A6.00).

<sup>3</sup> Third adjustment bolt and nut added to support middle of bed rail when loading or turning heavy logs (Rev. A3.00).

<sup>4</sup> Longer bed rail cover replaces S09944 originally supplied prior to Rev. A3.00. Longer covers protect entire bed rail surface.

# 7 Bed Frame

## Bed Rail #2 (Middle Front)

### 7.3 Bed Rail #2 (Middle Front)

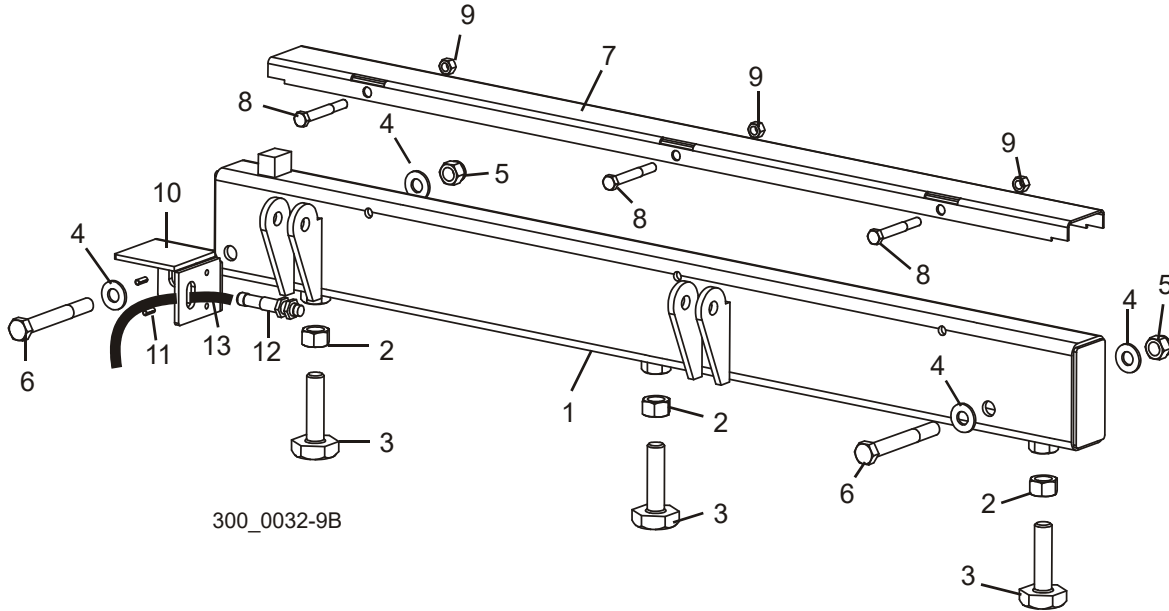

REF	DESCRIPTION (◆ Indicates Parts Available In Assemblies Only)	PART #	QTY.
	<b>RAIL ASSEMBLY, #2 BED (MIDDLE FRONT)</b>	035635 <sup>1</sup>	1
1	Rail Weldment, #2 Bed	035631 <sup>2</sup>	1
2	Nut, 5/8-11 Hex	F05010-5 <sup>3</sup>	3
3	Bolt, Bed Rail Adjustment	S13006 <sup>3</sup>	3
4	Washer, 1/2" SAE Flat	F05011-2	4
5	Nut, 1/2-13 Nylon Lock	F05010-8	2
6	Bolt, 1/2-13 x 4" Hex Head	F05008-26	2
7	Cover, Stainless Steel Bed Rail	016898 <sup>4</sup>	1
8	Bolt, 5/16-18 x 2 1/2" Hex Head	F05006-10	3
9	Nut, 5/16-18 Hex Lock	F05010-6	3
10	Bracket, Proximity Sensor Guard	035419 <sup>1</sup>	1
11	Pin, 3/16 x 1/2" Roll	F05012-35 <sup>1</sup>	2
12	<b>SENSOR, 12MM PROXIMITY</b>	025041 <sup>1</sup>	1
13	<b>CABLE, 12MM X 7M RA PROXIMITY SENSOR</b>	025120 <sup>1</sup>	1

<sup>1</sup> Toe roller sensors and hardware removed from bed rail assembly Rev. A6.00.

<sup>2</sup> Center adjustment nut on rail weldment replaced to make bed rail more durable (Rev. A6.00).

<sup>3</sup> Third adjustment bolt and nut added to support middle of bed rail when loading or turning heavy logs (Rev. A3.00).

<sup>4</sup> Longer bed rail cover replaces S09944 originally supplied prior to Rev. A3.00. Longer covers protect entire bed rail surface.

7.4 Bed Rail (Middle)

LT300

Rev. A7.00+

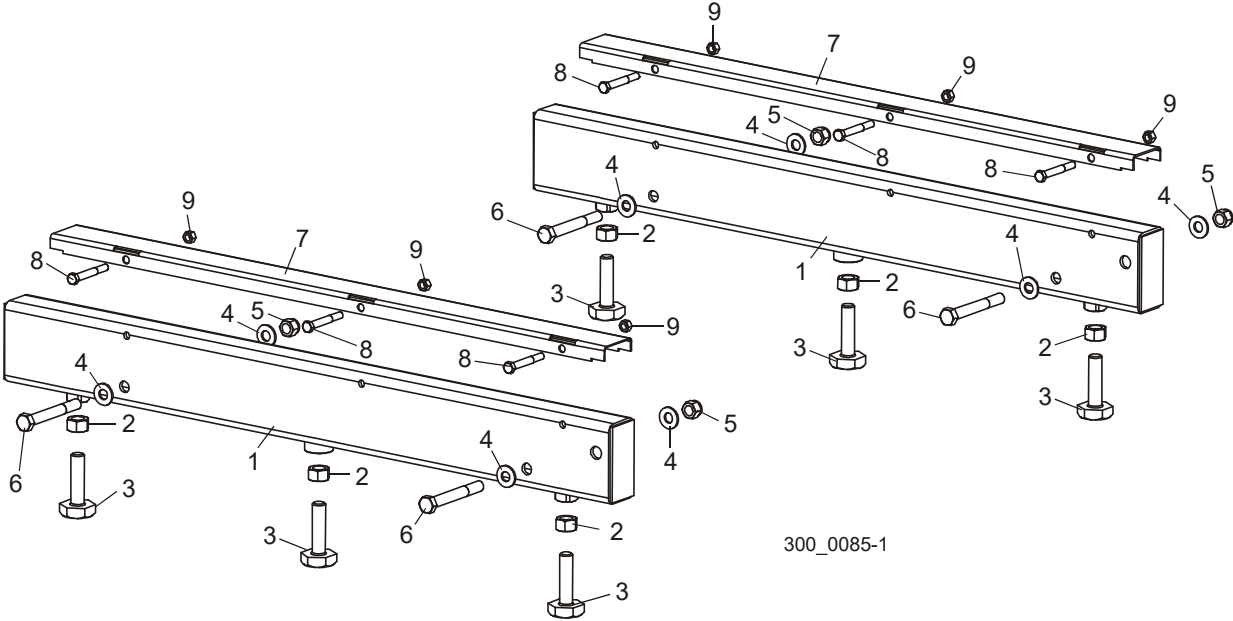

REF	DESCRIPTION (◆ Indicates Parts Available In Assemblies Only)	PART #	QTY.
	<b>RAIL ASSEMBLY, MIDDLE BED</b>	035639	2
1	Rail Weldment, Middle Bed	035638	1
2	Nut, 5/8-11 Hex	F05010-5	3
3	Bolt, Bed Rail Adjustment	S13006	3
4	Washer, 1/2" SAE Flat	F05011-2	4
5	Nut, 1/2-13 Nylon Lock	F05010-8	2
6	Bolt, 1/2-13 x 4" Hex Head	F05008-26	2
7	Cover, Stainless Steel Bed Rail	S09944	1
8	Bolt, 5/16-18 x 2 1/2" Hex Head	F05006-10	3
9	Nut, 5/16-18 Hex Lock	F05010-6	3

# 7 Bed Frame

## Bed Rail (Middle)

### 7.5 Bed Rail (Middle)

LT300

Rev. A1.00 - A6.01

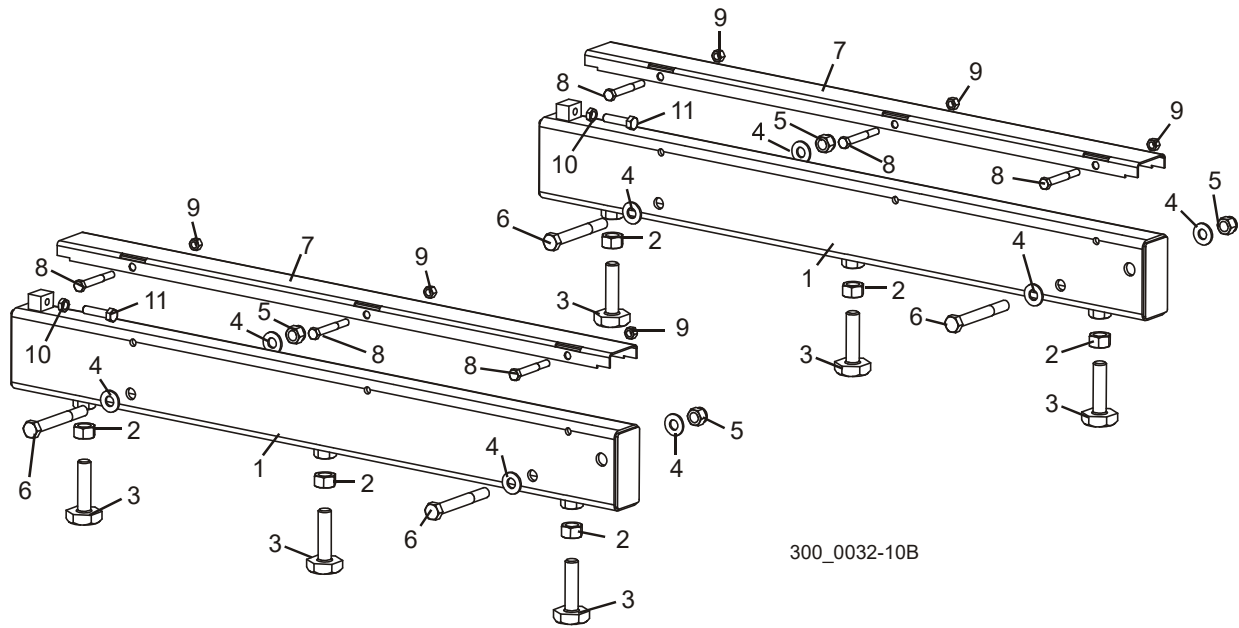

REF	DESCRIPTION (◆ Indicates Parts Available In Assemblies Only)	PART #	QTY.
	<b>RAIL ASSEMBLY, MIDDLE BED</b>	035639 <sup>1</sup>	2
1	Rail Weldment, Middle Bed	035638 <sup>2</sup>	1
2	Nut, 5/8-11 Hex	F05010-5 <sup>3</sup>	3
3	Bolt, Bed Rail Adjustment	S13006 <sup>3</sup>	3
4	Washer, 1/2" SAE Flat	F05011-2	4
5	Nut, 1/2-13 Nylon Lock	F05010-8	2
6	Bolt, 1/2-13 x 4" Hex Head	F05008-26	2
7	Cover, Stainless Steel Bed Rail	S09944	1
8	Bolt, 5/16-18 x 2 1/2" Hex Head	F05006-10	3
9	Nut, 5/16-18 Hex Lock	F05010-6	3
10	Nut, 3/8-16 Hex Jam	F05010-29 <sup>1</sup>	1
11	Bolt, 3/8-16 x 1 1/2" Hex Head Full Thread	F05007-17 <sup>1</sup>	1

<sup>1</sup> Stop bolt and jam nut removed Rev. A7.00 ([See Section 7.4](#))

<sup>2</sup> Center adjustment nut on rail weldment replaced to make bed rail more durable (Rev. A6.00).

<sup>3</sup> Third adjustment bolt and nut added to support middle of bed rail when loading or turning heavy logs (Rev. A3.00).



## 7.6 Bed Rail #4 (Middle Rear)

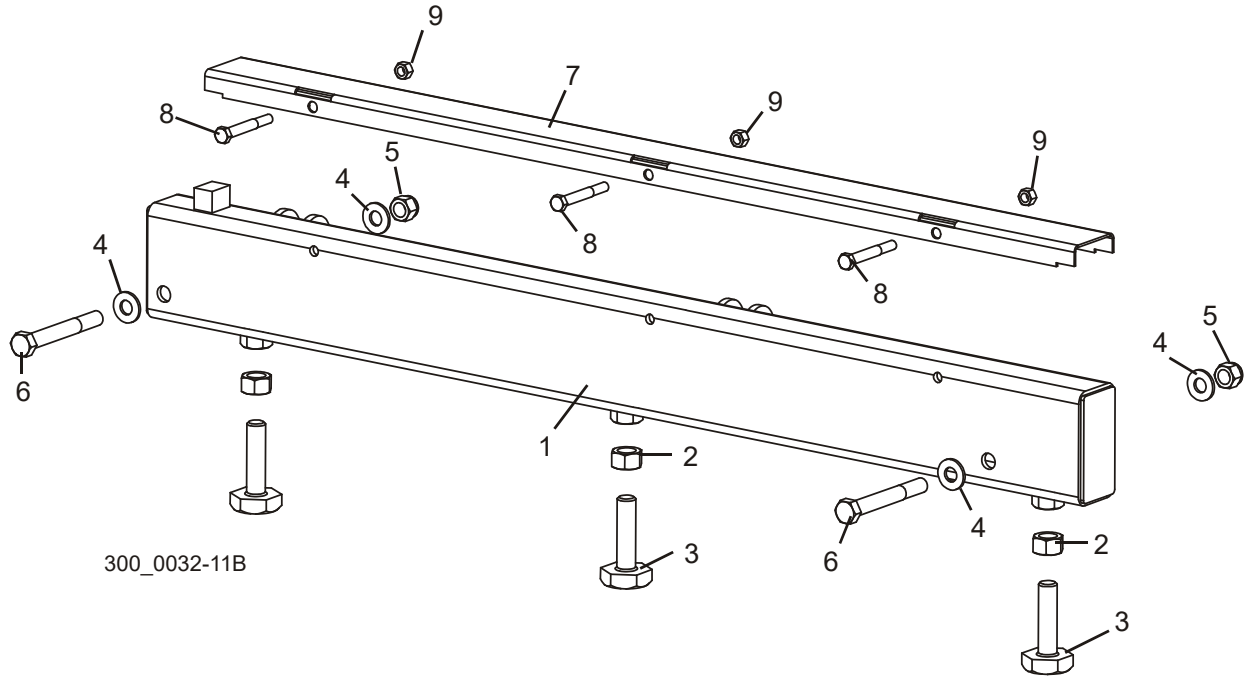

REF	DESCRIPTION (◆ Indicates Parts Available In Assemblies Only)	PART #	QTY.
	<b>RAIL ASSEMBLY, #4 BED (MIDDLE REAR)</b>	035636	1
1	Rail Weldment, #4 Bed	035632 <sup>1</sup>	1
2	Nut, 5/8-11 Hex	F05010-5 <sup>2</sup>	3
3	Bolt, Bed Rail Adjustment	S13006 <sup>2</sup>	3
4	Washer, 1/2" SAE Flat	F05011-2	4
5	Nut, 1/2-13 Nylon Lock	F05010-8	2
6	Bolt, 1/2-13 x 4" Hex Head	F05008-26	2
7	Cover, Stainless Steel Bed Rail	016898 <sup>3</sup>	1
8	Bolt, 5/16-18 x 2 1/2" Hex Head	F05006-10	3
9	Nut, 5/16-18 Hex Lock	F05010-6	3

<sup>1</sup> Center adjustment nut on rail weldment replaced to make bed rail more durable (Rev. A6.00).

<sup>2</sup> Third adjustment bolt and nut added to support middle of bed rail when loading or turning heavy logs (Rev. A3.00).

<sup>3</sup> Longer bed rail cover replaces S09944 originally supplied prior to Rev. A3.00. Longer covers protect entire bed rail surface.

# 7 Bed Frame

## Bed Rail #5 (Rear)

### 7.7 Bed Rail #5 (Rear)

LT300

Rev. A7.00+

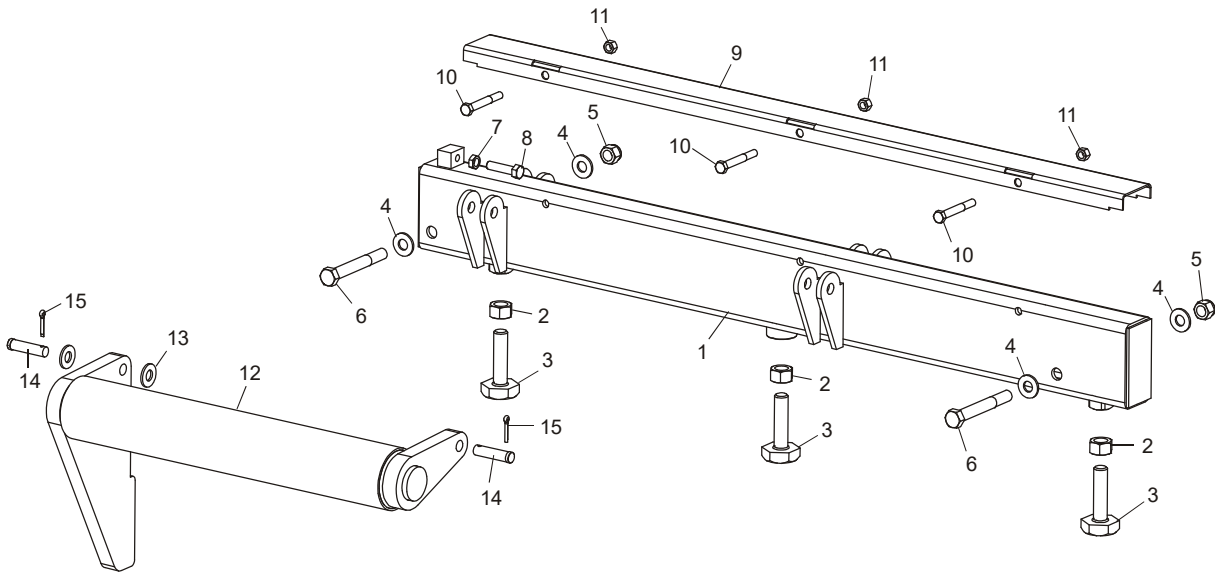

300\_0088-1

REF	DESCRIPTION (◆ Indicates Parts Available In Assemblies Only)	PART #	QTY.
	<b>RAIL ASSEMBLY, #5 BED (REAR)</b>	035637	1
1	Rail Weldment, #5 Bed	035633	1
2	Nut, 5/8-11 Hex	F05010-5	3
3	Bolt, Bed Rail Adjustment	S13006	3
4	Washer, 1/2" SAE Flat	F05011-2	4
5	Nut, 1/2-13 Nylon Lock	F05010-8	2
6	Bolt, 1/2-13 x 4" Hex Head	F05008-26	2
7	Nut, 3/8-16 Hex Jam	F05010-29	1
8	Bolt, 3/8-16 x 1 1/2" Hex Head Full Thread	F05007-17	1
9	Cover, Stainless Steel Bed Rail	016898	1
10	Bolt, 5/16-18 x 2 1/2" Hex Head	F05006-10	3
11	Nut, 5/16-18 Hex Lock	F05010-6	3
	<b>ROLLER ASSEMBLY, REAR BOARD</b>	036414	1
12	Roller Assembly, Toe Board	074852	1
13	Washer, 1/2" SAE Flat	F05011-2	2
14	Pin, 1/2" x 1 3/4" Clevis	F05012-82	2
15	Pin, 1/8" x 3/4" Cotter	F05012-3	2

## 7.8 Bed Rail #5

LT300

Rev. A1.00 - A6.01

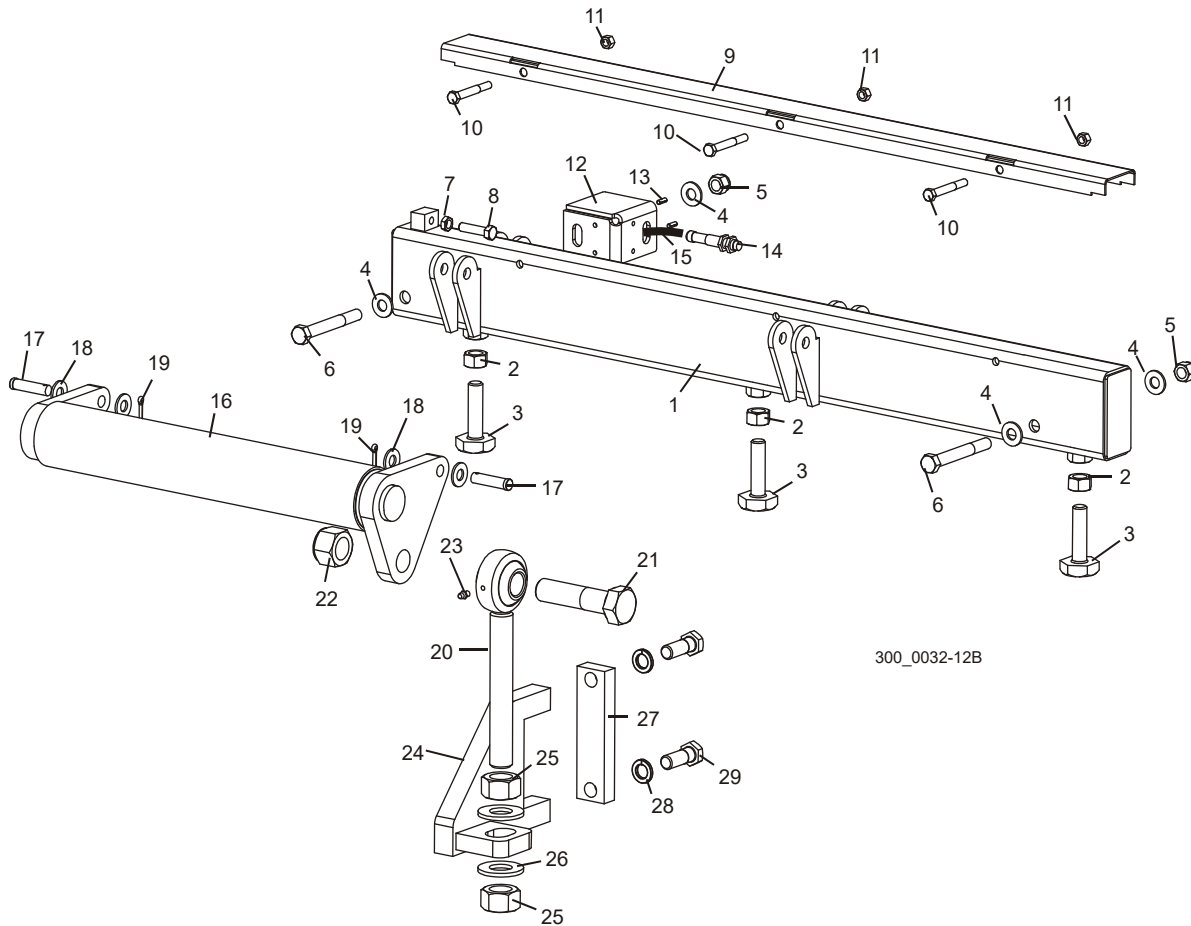

300\_0032-12B

REF	DESCRIPTION (◆ Indicates Parts Available In Assemblies Only)	PART #	QTY.
	<b>RAIL ASSEMBLY, #5 BED</b>	035637 <sup>1</sup>	1
1	Rail Weldment, #5 Bed	035633 <sup>2</sup>	1
2	Nut, 5/8-11 Hex	F05010-5 <sup>3</sup>	3
3	Bolt, Bed Rail Adjustment	S13006 <sup>3</sup>	3
4	Washer, 1/2" SAE Flat	F05011-2	4
5	Nut, 1/2-13 Nylon Lock	F05010-8	2
6	Bolt, 1/2-13 x 4" Hex Head	F05008-26	2
7	Nut, 3/8-16 Hex Jam	F05010-29	1
8	Bolt, 3/8-16 x 1 1/2" Hex Head Full Thread	F05007-17	1
9	Cover, Stainless Steel Bed Rail	016898 <sup>4</sup>	1
10	Bolt, 5/16-18 x 2 1/2" Hex Head	F05006-10	3
11	Nut, 5/16-18 Hex Lock	F05010-6	3
12	Bracket, Proximity Sensor Guard	035419 <sup>1</sup>	1

## 7

**Bed Frame***Bed Rail #5*

13	Pin, 3/16 x 1/2" Roll	F05012-35 <sup>1</sup>	2	
14	<b>SENSOR, 12MM PROXIMITY</b>	025041 <sup>1</sup>	1	
15	<b>CABLE, 12MM X 7M RA PROXIMITY SENSOR</b>	025120 <sup>1</sup>	1	
	<b>ROLLER ASSEMBLY, REAR BOARD</b>	017792 <sup>2</sup>	1	
16	Roller Weldment, Toe Board	W13025-1	1	
17	Pin, 1/2" x 1 3/4" Clevis	F05012-82	2	
18	Washer, 1/2" SAE Flat	F05011-2	2	
19	Pin, 1/8" x 3/4" Cotter	F05012-3	2	
20	Rod End Weldment, Board Roller	017794	1	
21	Bolt, 1-8 x 4" Hex Head	F05014-4	1	
22	Nut, 1-8 Hex Nylon Lock	F05010-109	1	
23	Fitting, 1/4-28 Grease	P05060	1	
24	Mount Weldment, Board Roller	017797	1	
25	Nut, 1-8 Hex	F05010-94	2	
26	Washer, 1" SAE Flat	F05011-28	2	
27	Plate, Toe Board Mount Strap	S13023	1	
28	Washer, 5/8" Split Lock	F05011-27	2	
29	Bolt, 5/8-11 x 1 3/4" Hex Head	F05009-33	2	

<sup>1</sup> Toe roller sensors and hardware removed from bed rail assembly Rev. A6.00.

<sup>2</sup> Center adjustment nut on rail weldment replaced to make bed rail more durable (Rev. A6.00). Bed rail modified to accept rear board roller assembly. Board roller added to prevent boards getting hung up on bed rail (Rev. A3.00). Board Roller replaced with fixed roller assembly Rev. A7.00 ([See Section 7.7](#)).

<sup>3</sup> Third adjustment bolt and nut added to support middle of bed rail when loading or turning heavy logs (Rev. A3.00).

<sup>4</sup> Longer bed rail cover replaces S09944 originally supplied prior to Rev. A3.00. Longer covers protect entire bed rail surface.

## 7.9 Leg Assembly (Front & Rear)

LT300

Rev. B4.00+ (with Pantograph Cable Boom)

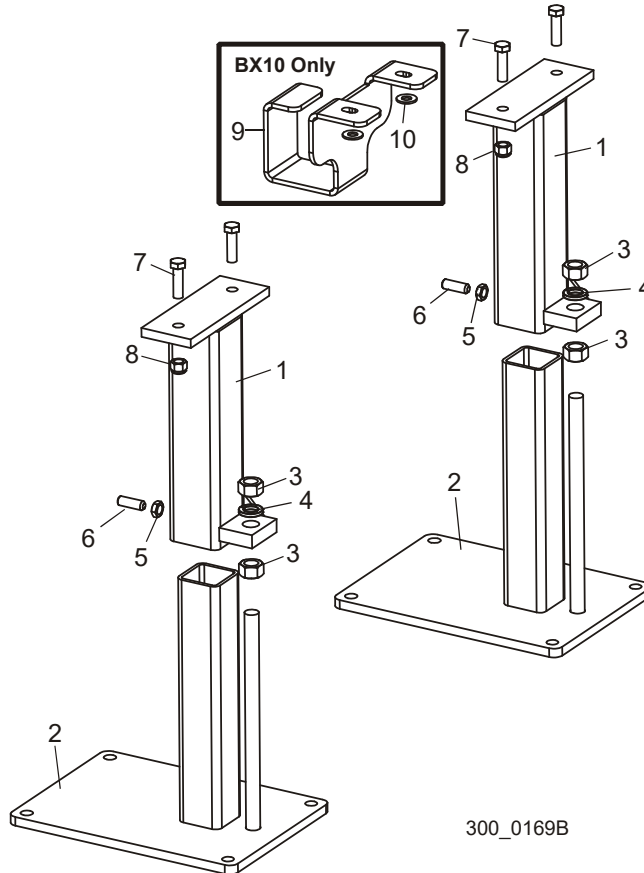

REF	DESCRIPTION (◆ Indicates Parts Available In Assemblies Only)	PART #	QTY.
	<b>LEG ASSEMBLY, FRONT/REAR</b>	006785	2
1	Leg Weldment, Front/Rear	006786	1
2	Plate Weldment, 10" x 13 3/4" Foot	006791	1
3	Nut, 3/4-16 Hex	F05010-92	2
4	Washer, 3/4" Split Lock	F05011-6	1
5	Nut, 1/2-13 Hex Jam	F05010-31	1
6	Screw, 1/2-13 x 1 1/2" Socket Head Flat Point Set	F05008-31	1
7	Bolt, 1/2-13 x 1 3/4" Hex Head Grade 5	F05008-88	2
8	Nut, 1/2-13 Hex Nylon Lock	F05010-8	2
9	<b>BRACKET, BX10 HYDRAULIC HOSE HANGER</b>	008750	1
10	<b>WASHER, 1/2" SAE FLAT</b>	F05011-2	2

# 7 Bed Frame

## Leg Assembly (Front & Rear)

### 7.10 Leg Assembly (Front & Rear)

LT300  
LT300

Rev. A7.00 - B3.02  
Rev. B4.00+ (without Pantograph Cable Boom)

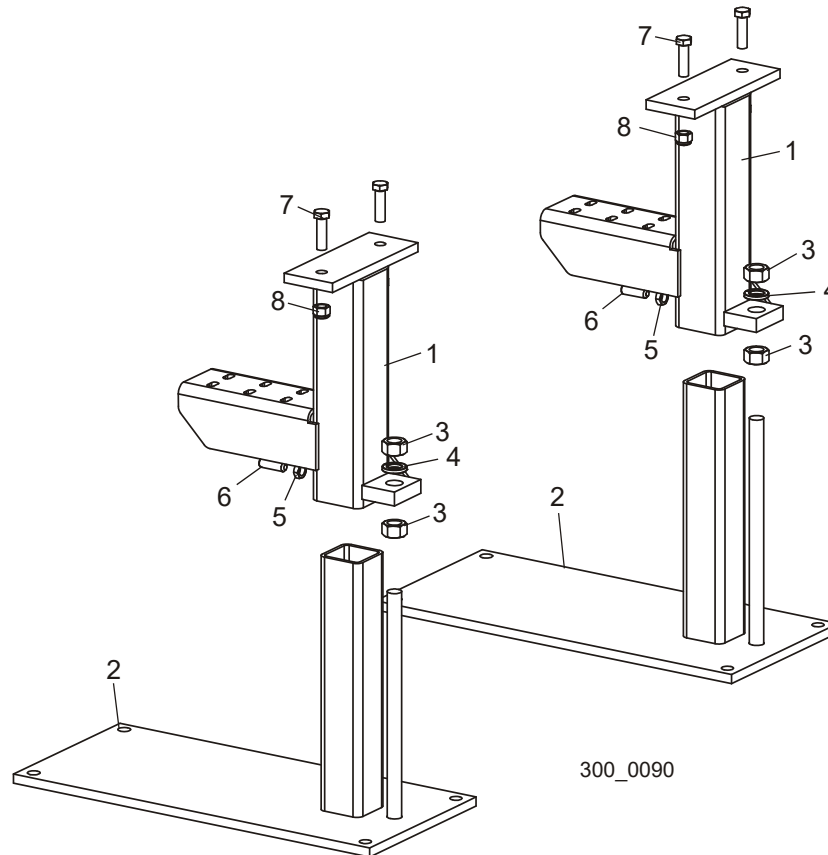

REF	DESCRIPTION (◆ Indicates Parts Available In Assemblies Only)	PART #	QTY.
	<b>LEG ASSEMBLY, FRONT/REAR</b>	036453 <sup>1</sup>	2
1	Leg Weldment, Front/Rear	036454 <sup>2</sup>	1
2	Plate Weldment, Front/Rear Leg Foot	051355	1
3	Nut, 3/4-16 Hex	F05010-92	2
4	Washer, 3/4" Split Lock	F05011-6	1
5	Nut, 1/2-13 Hex Jam	F05010-31	1
6	Screw, 1/2-13 x 1 1/2" Socket Head Flat Point Set	F05008-31	1
7	Bolt, 1/2-13 x 1 3/4" Hex Head Grade 5	F05008-88	2
8	Nut, 1/2-13 Hex Nylon Lock	F05010-8	2

<sup>1</sup> Legs with cable carrier supports and longer foot plates supplied in kit 006806 Rev. B4.00+ instead of Pantograph for customers with space constraints.

<sup>2</sup> Leg weldments modified for use with LT300-BX6 to mount wireway. Wireway mount brackets 036437 replaced with 038464. If replacement required, specify legs are for LT300-BX6.

## 7.11 Leg Assembly (Front & Rear)

LT300

Rev. A5.00 - A6.01

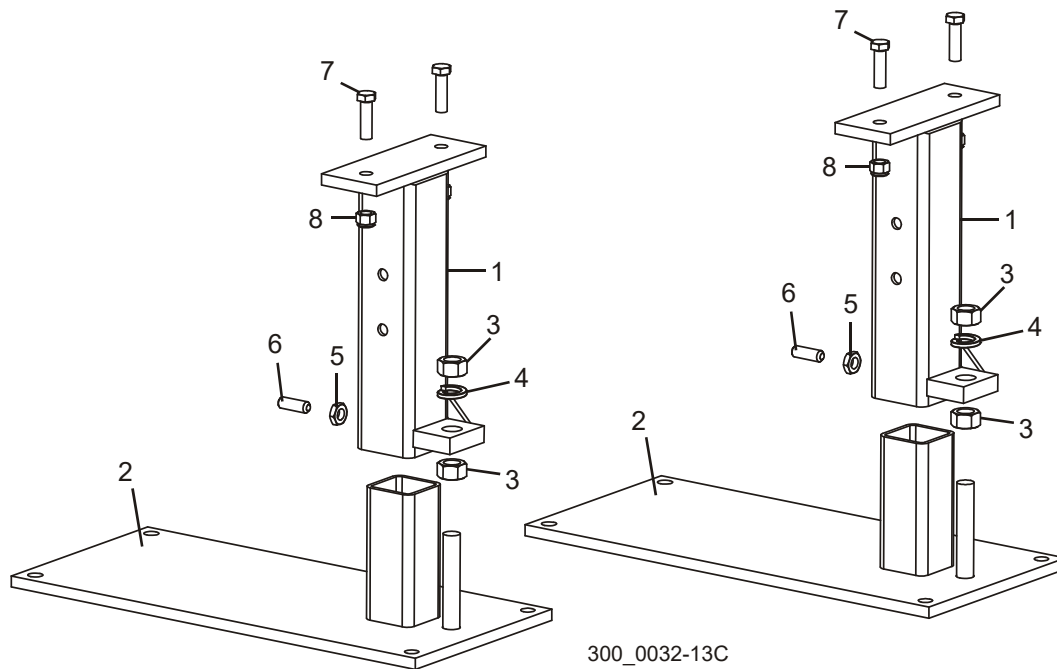

REF	DESCRIPTION (◆ Indicates Parts Available In Assemblies Only)	PART #	QTY.
	<b>LEG ASSEMBLY, FRONT/REAR</b>	016858	2
1	Leg Weldment, Front/Rear	035643	1
2	Plate Weldment, Front/Rear Leg Foot	016857	1
3	Nut, 3/4-16 Hex	F05010-92	2
4	Washer, 3/4" Split Lock	F05011-6	1
5	Nut, 1/2-13 Hex Jam	F05010-31	1
6	Screw, 1/2-13 x 1 1/2" Socket Head Flat Point Set	F05008-31	1
7	Bolt, 1/2-13 x 1 3/4" Hex Head Grade 5	F05008-88	2
8	Nut, 1/2-13 Hex Nylon Lock	F05010-8	2

# 7 Bed Frame

## Leg Assembly (Front & Rear)

### 7.12 Leg Assembly (Front & Rear)

LT300

Rev. A1.00 - A4.00

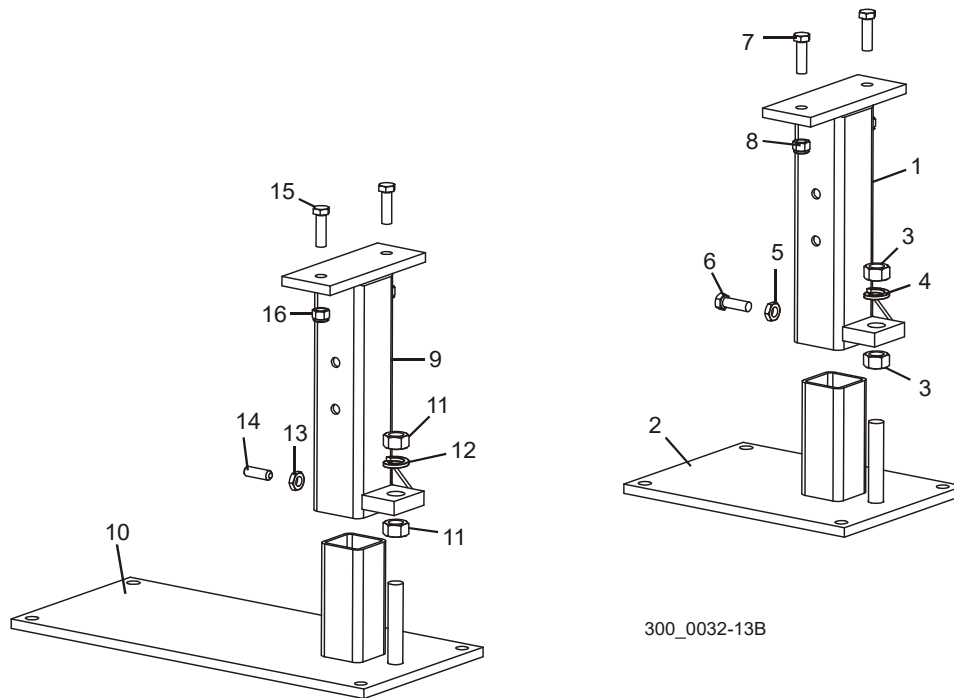

REF	DESCRIPTION (◆ Indicates Parts Available In Assemblies Only)	PART #	QTY.
	<b>LEG ASSEMBLY, FRONT</b>	035644	1
1	Leg Weldment, Front/Rear	035643	1
2	Plate Weldment, Front Leg Foot	016856	1
3	Nut, 3/4-16 Hex	F05010-92	2
4	Washer, 3/4" Split Lock	F05011-6	1
5	Nut, 1/2-13 Hex Jam	F05010-31	1
6	Bolt, 1/2-13 x 1 1/2" Hex Head Grade 5	F05008-33	1
7	Bolt, 1/2-13 x 1 3/4" Hex Head Grade 5	F05008-88	2
8	Nut, 1/2-13 Hex Nylon Lock	F05010-8	2
	<b>LEG ASSEMBLY, REAR</b>	016858	1
9	Leg Weldment, Front/Rear	035643	1
10	Plate Weldment, Rear Leg Foot	016857	1
11	Nut, 3/4-16 Hex	F05010-92	2
12	Washer, 3/4" Split Lock	F05011-6	1
13	Nut, 1/2-13 Hex Jam	F05010-31	1
14	Screw, 1/2-13 x 1 1/2" Socket Head Flat Point Set	F05008-31 <sup>1</sup>	1
15	Bolt, 1/2-13 x 1 3/4" Hex Head Grade 5	F05008-88	2
16	Nut, 1/2-13 Hex Nylon Lock	F05010-8	2

<sup>1</sup> Replaces hex head bolt F05008-33 supplied prior to Rev. A3.00. Set screw allows tightening of jam nut with socket wrench.



### 7.13 Leg Assembly (#1 & #2)

LT300

Rev. A1.00 - A4.00

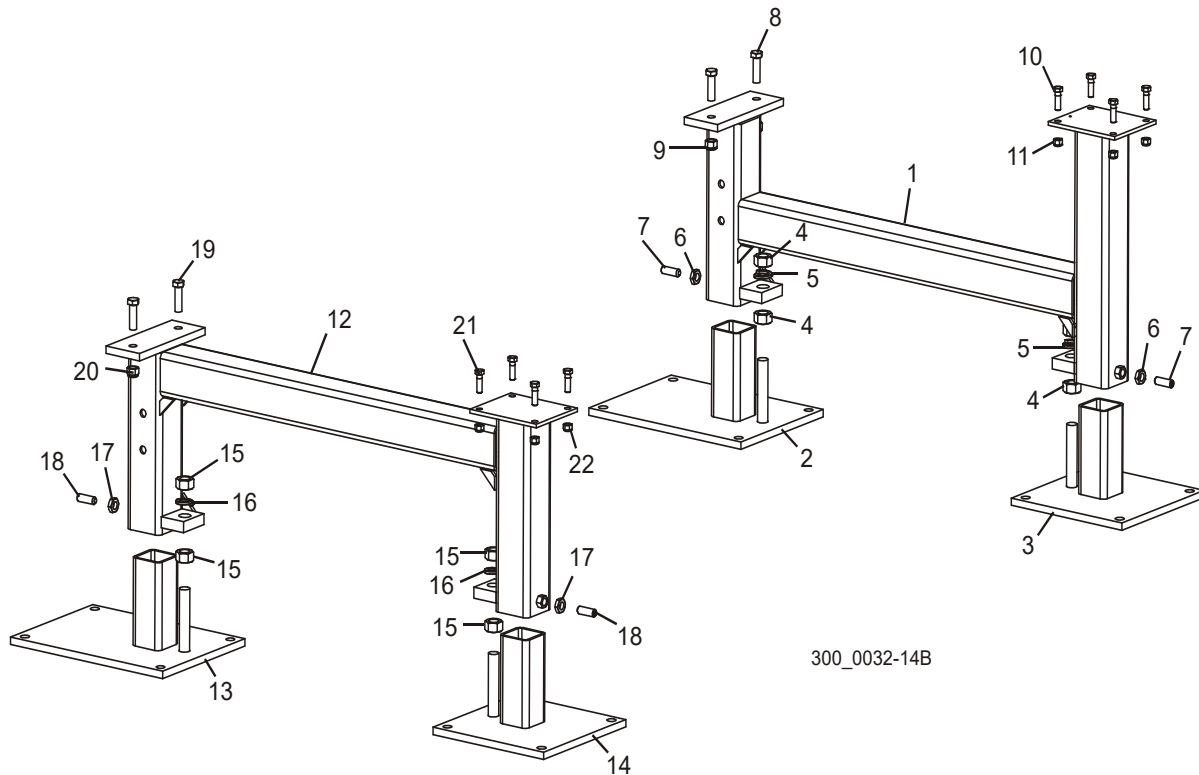

300\_0032-14B

REF	DESCRIPTION (◆ Indicates Parts Available In Assemblies Only)	PART #	QTY.
	<b>LEG ASSEMBLY, #1</b>	045082	1
1	Leg Weldment, Tall	045075	1
2	Plate Weldment, 10" x 13 3/4" Foot	016856	1
3	Plate Weldment, 10" x 10" Foot	045077	1
4	Nut, 3/4-16 Hex	F05010-92	4
5	Washer, 3/4" Split Lock	F05011-6	2
6	Nut, 1/2-13 Hex Jam	F05010-31	2
7	Screw, 1/2-13 x 1 1/2" Socket Head Flat Point Set	F05008-31 <sup>1</sup>	2
8	Bolt, 1/2-13 x 1 3/4" Hex Head Grade 5	F05008-88	2
9	Nut, 1/2-13 Hex Nylon Lock	F05010-8	2
10	Bolt, 3/8-16 x 1 1/4" Hex Head Grade 5	F05007-123	4
11	Nut, 3/8-16 Hex Nylon Lock	F05010-10	4
	<b>LEG ASSEMBLY, #2</b>	045081	1
12	Leg Weldment, Short	045071	1
13	Plate Weldment, 10" x 13 3/4" Foot	016856	1
14	Plate Weldment, 10" x 10" Foot	045077	1
15	Nut, 3/4-16 Hex	F05010-92	4

**7****Bed Frame***Leg Assembly (#1 & #2)*

---

<b>16</b>	Washer, 3/4" Split Lock	F05011-6	2	
<b>17</b>	Nut, 1/2-13 Hex Jam	F05010-31	2	
<b>18</b>	Screw, 1/2-13 x 1 1/2" Socket Head Flat Point Set	F05008-31 <sup>1</sup>	2	
<b>19</b>	Bolt, 1/2-13 x 1 3/4" Hex Head Grade 5	F05008-88	2	
<b>20</b>	Nut, 1/2-13 Hex Nylon Lock	F05010-8	2	
<b>21</b>	Bolt, 3/8-16 x 1 1/4" Hex Head Grade 5	F05007-123	4	
<b>22</b>	Nut, 3/8-16 Hex Nylon Lock	F05010-10	4	

<sup>1</sup> Replaces hex head bolt F05008-33 supplied prior to Rev. A3.00. Set screw allows tightening of jam nut with socket wrench.

### 7.14 Leg Assembly (#2 & #5)

LT300

Rev. B4.00+ (with Pantograph Cable Boom)

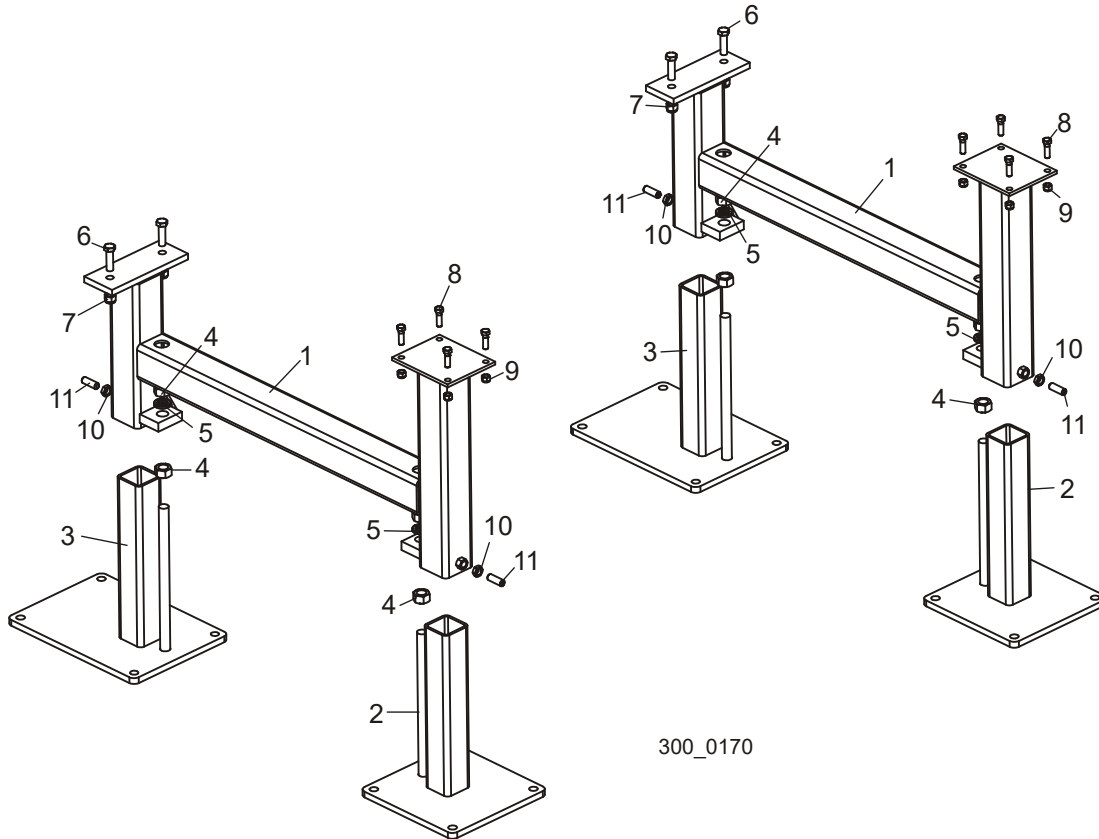

REF	DESCRIPTION (◆ Indicates Parts Available In Assemblies Only)	PART #	QTY.
	<b>LEG ASSEMBLY, #2 &amp; #5</b>	006787	2
1	Leg Weldment, Tall	006788	1
2	Plate Weldment, 10" x 10" Foot	051363	1
3	Plate Weldment, 10" x 13 3/4" Foot	006791	1
4	Nut, 3/4-16 Hex	F05010-92	4
5	Washer, 3/4" Split Lock	F05011-6	2
6	Bolt, 1/2-13 x 1 3/4" Hex Head Grade 5	F05008-88	2
7	Nut, 1/2-13 Hex Nylon Lock	F05010-8	2
8	Bolt, 3/8-16 x 1 1/4" Hex Head Grade 5	F05007-123	4
9	Nut, 3/8-16 Hex Nylon Lock	F05010-10	4
10	Nut, 1/2-13 Hex Jam	F05010-31	2
11	Screw, 1/2-13 x 1 1/2" Socket Head Flat Point Set	F05008-31	2

# 7 Bed Frame

## Leg Assembly (#2 & #5)

### 7.15 Leg Assembly (#2 & #5)

LT300  
LT300

Rev. A7.00 - B3.02  
Rev. B4.00+ (without Pantograph Cable Boom)

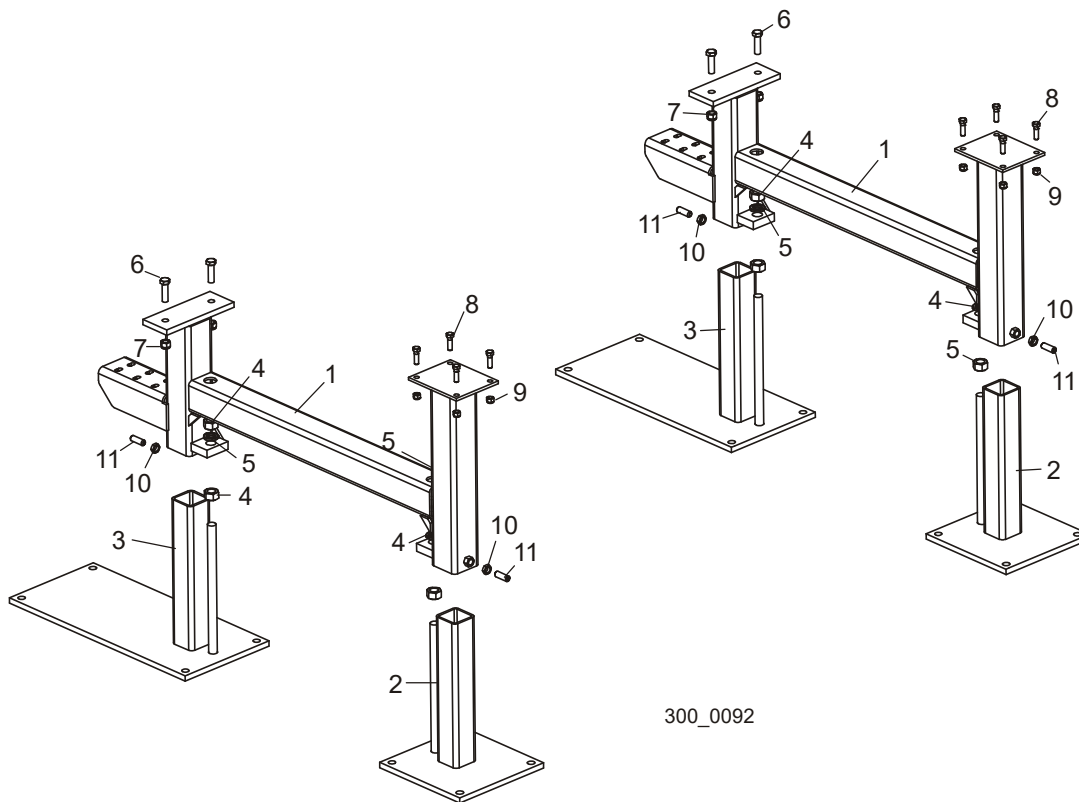

300\_0092

REF	DESCRIPTION (◆ Indicates Parts Available In Assemblies Only)	PART #	QTY.
	<b>LEG ASSEMBLY, #2 &amp; #5</b>	036456 <sup>1</sup>	2
1	Leg Weldment, Tall	036457 <sup>2</sup>	1
2	Plate Weldment, 10" x 10" Foot	051363	1
3	Plate Weldment, 10" x 22" Foot	051355	1
4	Nut, 3/4-16 Hex	F05010-92	4
5	Washer, 3/4" Split Lock	F05011-6	2
6	Bolt, 1/2-13 x 1 3/4" Hex Head Grade 5	F05008-88	2
7	Nut, 1/2-13 Hex Nylon Lock	F05010-8	2
8	Bolt, 3/8-16 x 1 1/4" Hex Head Grade 5	F05007-123	4
9	Nut, 3/8-16 Hex Nylon Lock	F05010-10	4
10	Nut, 1/2-13 Hex Jam	F05010-31	2
11	Screw, 1/2-13 x 1 1/2" Socket Head Flat Point Set	F05008-31	2

<sup>1</sup> Legs with cable carrier supports and longer foot plates supplied in kit 006806 Rev. B4.00+ instead of Pantograph for customers with space constraints.

<sup>2</sup> Leg weldments modified for use with LT300-BX6 to mount wireway. Wireway mount brackets 036437 replaced with 038464. If replacement required, specify legs are for LT300-BX6.

### 7.16 Leg Assembly (#3 & #4)

LT300

Rev. B4.00+ (with Pantograph Cable Boom)

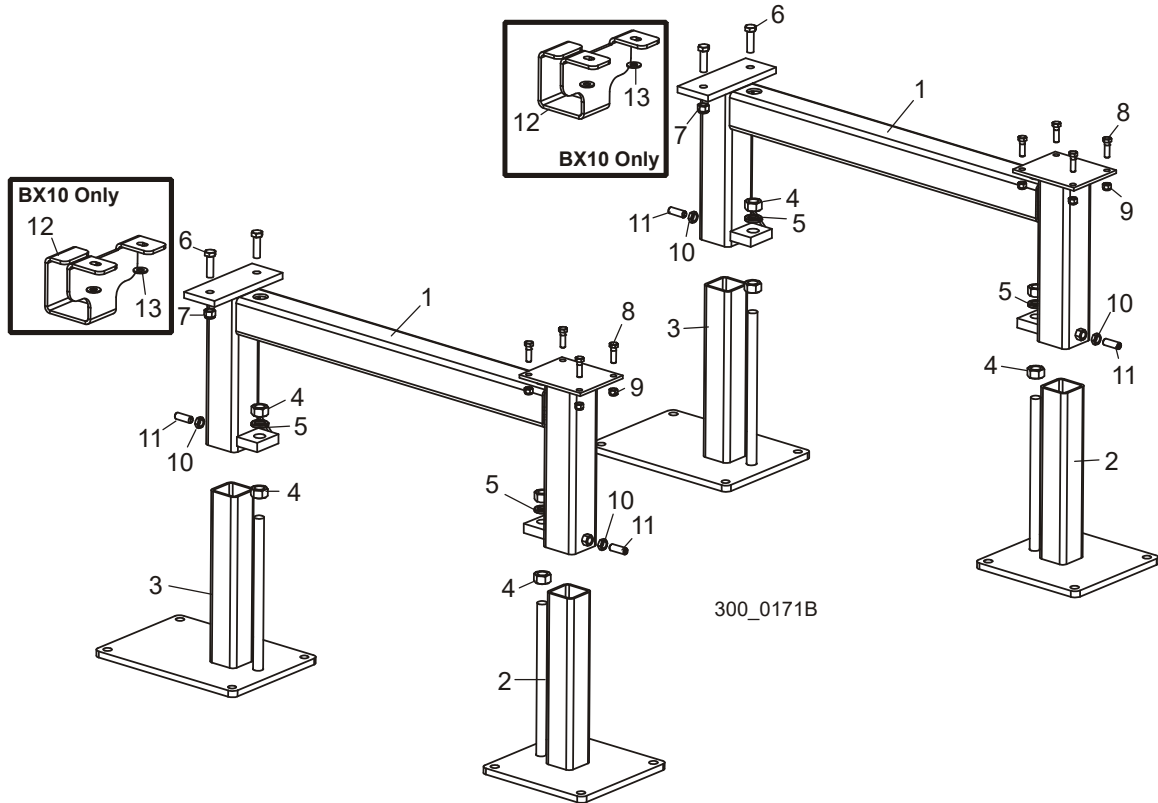

REF	DESCRIPTION (◆ Indicates Parts Available In Assemblies Only)	PART #	QTY.
	<b>LEG ASSEMBLY, #3 &amp; #4</b>	006789	2
1	Leg Weldment, Short	006790	1
2	Plate Weldment, 10" x 10" Foot	051363	1
3	Plate Weldment, 10" x 13 3/4" Foot	006791	1
4	Nut, 3/4-16 Hex	F05010-92	4
5	Washer, 3/4" Split Lock	F05011-6	2
6	Bolt, 1/2-13 x 1 3/4" Hex Head Grade 5	F05008-88	2
7	Nut, 1/2-13 Hex Nylon Lock	F05010-8	2
8	Bolt, 3/8-16 x 1 1/4" Hex Head Grade 5	F05007-123	4
9	Nut, 3/8-16 Hex Nylon Lock	F05010-10	4
10	Nut, 1/2-13 Hex Jam	F05010-31	2
11	Screw, 1/2-13 x 1 1/2" Socket Head Flat Point Set	F05008-31	2
12	<b>BRACKET, BX10 HYDRAULIC HOSE HANGER</b>	008750	2
13	<b>WASHER, 1/2" SAE FLAT</b>	F05011-2	4

# 7 Bed Frame

## Leg Assembly (#3 & #4)

### 7.17 Leg Assembly (#3 & #4)

LT300  
LT300

Rev. A7.00 - B3.02  
Rev. B4.00+ (without Pantograph Cable Boom)

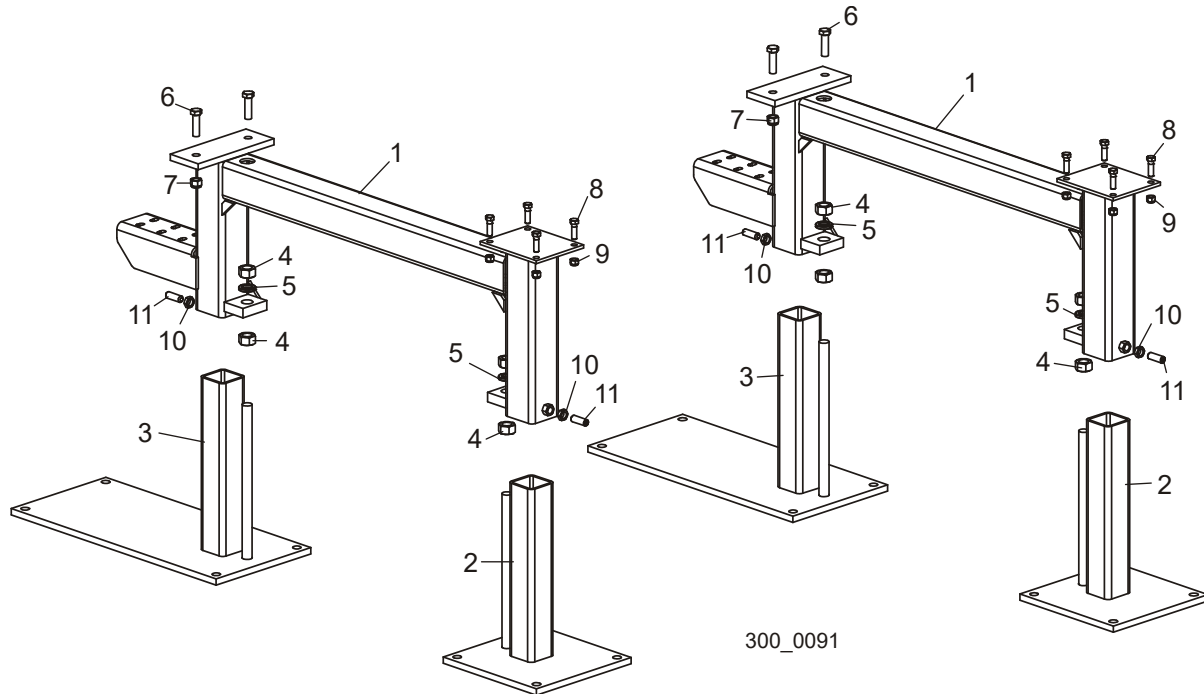

REF	DESCRIPTION (◆ Indicates Parts Available In Assemblies Only)	PART #	QTY.
	<b>LEG ASSEMBLY, #3 &amp; #4</b>	036459 <sup>1</sup>	2
1	Leg Weldment, Short	036460 <sup>2</sup>	1
2	Plate Weldment, 10" x 10" Foot	051363	1
3	Plate Weldment, 10" x 22" Foot	051355	1
4	Nut, 3/4-16 Hex	F05010-92	4
5	Washer, 3/4" Split Lock	F05011-6	2
6	Bolt, 1/2-13 x 1 3/4" Hex Head Grade 5	F05008-88	2
7	Nut, 1/2-13 Hex Nylon Lock	F05010-8	2
8	Bolt, 3/8-16 x 1 1/4" Hex Head Grade 5	F05007-123	4
9	Nut, 3/8-16 Hex Nylon Lock	F05010-10	4
10	Nut, 1/2-13 Hex Jam	F05010-31	2
11	Screw, 1/2-13 x 1 1/2" Socket Head Flat Point Set	F05008-31	2

<sup>1</sup> Legs with cable carrier supports and longer foot plates supplied in kit 006806 Rev. B4.00+ instead of Pantograph for customers with space constraints.

<sup>2</sup> Leg weldments modified for use with LT300-BX6 to mount wireway. Wireway mount brackets 036437 replaced with 038464. If replacement required, specify legs are for LT300-BX6.

## 7.18 Leg Assembly (#3 & #4)

LT300

Rev. A1.00 - A6.01

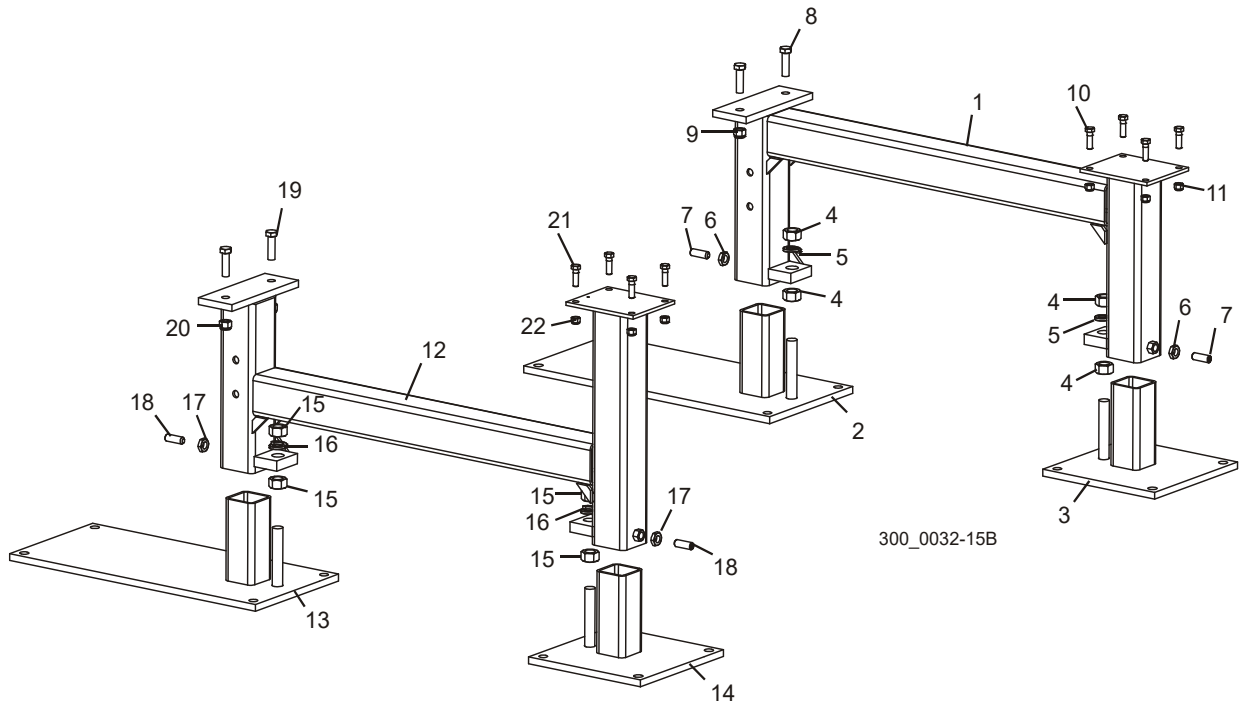

REF	DESCRIPTION (◆ Indicates Parts Available In Assemblies Only)	PART #	QTY.
	<b>LEG ASSEMBLY, #3</b>	016861	1
1	Leg Weldment, Short	045071	1
2	Plate Weldment, 10" x 22" Foot	016857	1
3	Plate Weldment, 10" x 10" Foot	045077	1
4	Nut, 3/4-16 Hex	F05010-92	4
5	Washer, 3/4" Split Lock	F05011-6	2
6	Nut, 1/2-13 Hex Jam	F05010-31	2
7	Screw, 1/2-13 x 1 1/2" Socket Head Flat Point Set	F05008-31 <sup>1</sup>	2
8	Bolt, 1/2-13 x 1 3/4" Hex Head Grade 5	F05008-88	2
9	Nut, 1/2-13 Hex Nylon Lock	F05010-8	2
10	Bolt, 3/8-16 x 1 1/4" Hex Head Grade 5	F05007-123	4
11	Nut, 3/8-16 Hex Nylon Lock	F05010-10	4
	<b>LEG ASSEMBLY, #4</b>	016859	1
12	Leg Weldment, Tall	045075	1
13	Plate Weldment, 10" x 22" Foot	016857	1
14	Plate Weldment, 10" x 10" Foot	045077	1
15	Nut, 3/4-16 Hex	F05010-92	4

**7****Bed Frame***Leg Assembly (#3 & #4)*

---

<b>16</b>	Washer, 3/4" Split Lock	F05011-6	2	
<b>17</b>	Nut, 1/2-13 Hex Jam	F05010-31	2	
<b>18</b>	Screw, 1/2-13 x 1 1/2" Socket Head Flat Point Set	F05008-31 <sup>1</sup>	2	
<b>19</b>	Bolt, 1/2-13 x 1 3/4" Hex Head Grade 5	F05008-88	2	
<b>20</b>	Nut, 1/2-13 Hex Nylon Lock	F05010-8	2	
<b>21</b>	Bolt, 3/8-16 x 1 1/4" Hex Head Grade 5	F05007-123	4	
<b>22</b>	Nut, 3/8-16 Hex Nylon Lock	F05010-10	4	

<sup>1</sup> Replaces hex head bolt F05008-33 supplied prior to Rev. A3.00. Set screw allows tightening of jam nut with socket wrench.



## 7.19 Wireway

LT300  
LT300

Rev. A7.00 - B3.02  
Rev. B4.00+ (without Pantograph Cable Boom)

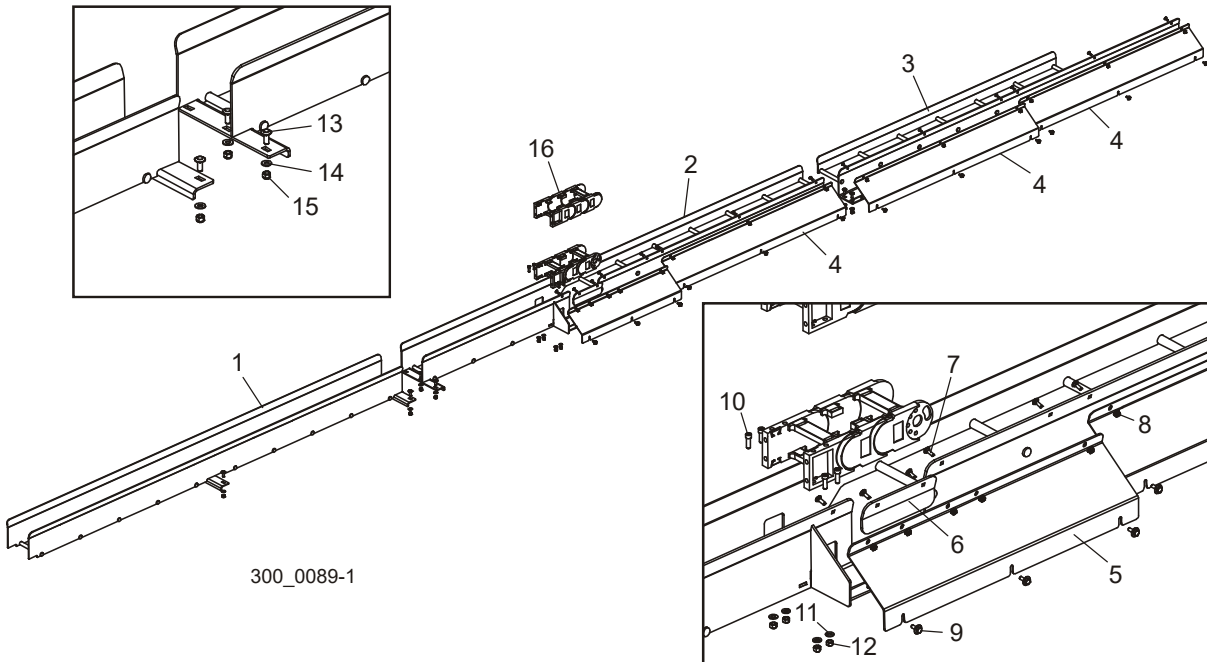

REF	DESCRIPTION (◆ Indicates Parts Available In Assemblies Only)	PART #	QTY.
	<b>WIREWAY ASSEMBLY, 26' LT300 BED</b>	036425 <sup>1</sup>	1
1	Wireway Weldment, 104.22" LT300	036430	1
2	Wireway Weldment, 111.90" LT300	036433	1
3	Wireway Weldment, 94.88" LT300	036427	1
4	Cover, LT300 Wireway 47.4"	036426	3
5	Cover, LT300 Wireway 27.66"	036446	1
6	Plate, LT300 Wireway Splice	036451	1
7	Bolt, 1/4-20 x 3/4" Carriage Head	F05005-113	14
8	Nut, 1/4-20 Self-Locking Hex	F05010-9	14
9	Bolt, 1/4-20 x 3/4" Hex Head w/Conical Washer	F05005-134	12
10	Bolt, 5/16-18 x 1" Socket Head	F05006-19	4
11	Washer, 5/16" SAE Flat	F05011-17	4
12	Nut, 5/16-18 Hex Lock	F05010-6	4
13	Bolt, 3/8-16 x 1" Carriage Head Grade 5	F05007-165	16
14	Washer, 3/8" SAE Flat	F05011-3	16
15	Nut, 3/8-16 Hex Nylon Lock	F05010-10	16
16	<b>CABLE CARRIER PARTS (See Section 7.23)</b>		

<sup>1</sup> Wireway supplied in kit 006806 Rev. B4.00+ instead of Pantograph for customers with space constraints.

# 7 Bed Frame

## Wireway (LT300-BX6)

### 7.20 Wireway (LT300-BX6)

LT300-BX6

Rev. A7.00 - B3.02

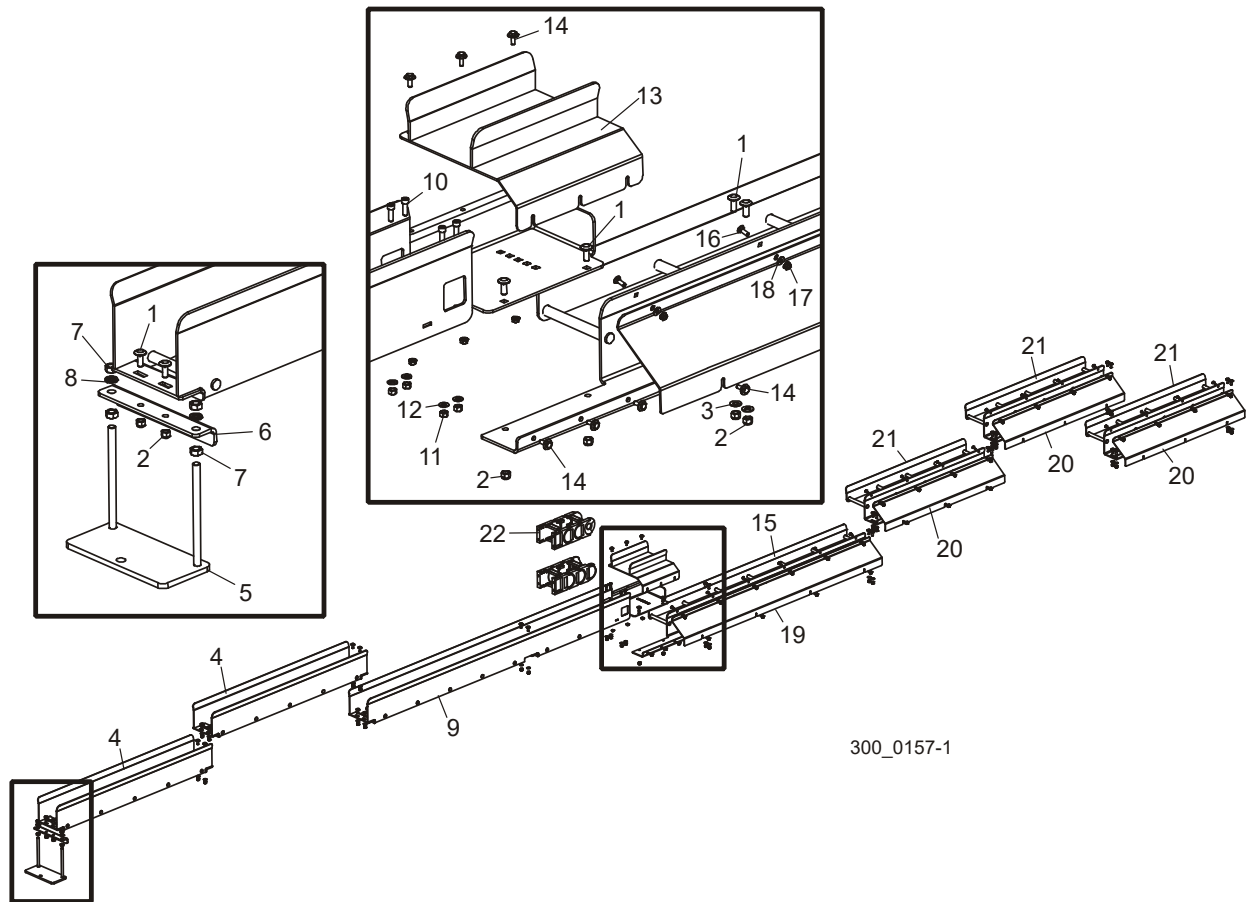

300\_0157-1

REF	DESCRIPTION (◆ Indicates Parts Available In Assemblies Only)	PART #	QTY.
	<b>WIREWAY ASSEMBLY, LT300-BX6</b>	038463	1
1	Bolt, 3/8-16 x 1 Carriage, Zinc Grade 5	F05007-165	28
2	Nut, 3/8-16 Hex Nylon Lock	F05010-10	28
3	Washer, 3/8 Flat SAE	F05011-3	26
4	Tray Weldment, 52.05	036131	2
	Support Assembly, Tray	036156	1
5	Support Weldment, Tray	036159	1
6	Angle, Tray Support	036158	1
7	Nut, 1/2-13 Hex	F05010-35	4
8	Washer, 1/2 Split Lock	F05011-9	2
9	Tray Weldment, 88.00	036128	1
10	Bolt, 5/16-18x1 Socket Head Cap B/O	F05006-19	4

11	Nut, 5/16-18 Swaged Hex	F05010-6	4	
12	Washer, 5/16 SAE Flat	F05011-17	4	
13	Cover Weldment, Wire Box	036140	1	
14	Bolt, 1/4-20x3/4 Hex Head w/Conical Washer	F05005-134	13	
15	Wireway/Tray Weldment, 78.74	036137	1	
16	Bolt, 1/4-20 x 3/4 Carriage	F05005-113	18	
17	Nut, 1/4-20 Keps	F05010-9	21	
18	Washer, 1/4 SAE Flat	F05011-11	18	
19	Wireway Cover, 66.41	036124	1	
20	Wireway Cover, 40.05	036122	3	
21	Wireway/Tray Weldment, 40.05	036130	3	
22	<b>CABLE CARRIER PARTS</b> ( <a href="#">See Section 7.23</a> )			

## 7.21 Wireway

LT300

Rev. A5.00 - A6.01

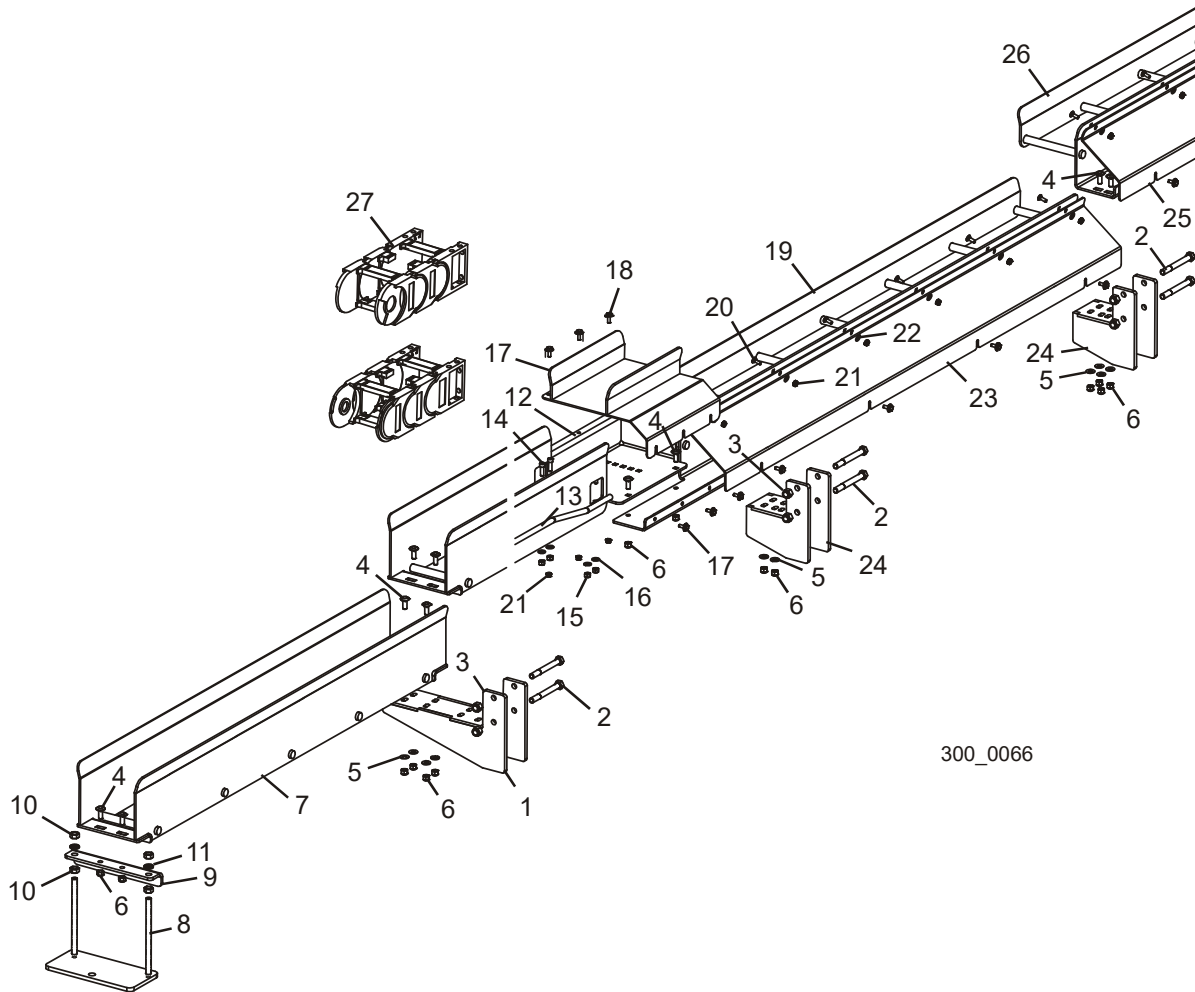

300\_0066

REF	DESCRIPTION (◆ Indicates Parts Available In Assemblies Only)	PART #	QTY.
	<b>WIREWAY ASSEMBLY, 26' LT300 BED</b>	036120	1
1	Hanger Weldment, Long	042115	3
2	Bolt, 1/2-13 x 4 1/2 Hex Head Grade 5	F05008-35	12
3	Nut, 1/2-13 Nylon Hex Lock	F05010-8	12
4	Bolt, 3/8-16 x 1 Carriage, Zinc Grade 5	F05007-165	23
5	Nut, 3/8-16 Hex Nylon Lock	F05010-10	23
6	Washer, 3/8 Flat SAE	F05011-3	21
7	Tray Weldment, 52.05	036131	2
	Support Assembly, Tray	036156	1
8	Support Weldment, Tray	036159	1
9	Angle, Tray Support	036158	1

10	Nut, 1/2-13 Hex	F05010-35	4	
11	Washer, 1/2 Split Lock	F05011-9	2	
12	Tray Weldment, 88.00	036128	1	
13	Conduit, Prox Wire	036201 <sup>1</sup>	1	
14	Bolt, 5/16-18x1 Socket Head Cap B/O	F05006-19	4	
15	Nut, 5/16-18 Swaged Hex	F05010-6	4	
16	Washer, 5/16 SAE Flat	F05011-17	4	
17	Cover Weldment, Wire Box	036140	1	
18	Bolt, 1/4-20x3/4 Hex Head w/Conical Washer	F05005-134	6	
19	Wireway/Tray Weldment, 78.74	036137	1	
20	Bolt, 1/4-20 x 3/4 Carriage	F05005-113	10	
21	Nut, 1/4-20 Keps	F05010-9	10	
22	Washer, 1/4 SAE Flat	F05011-11	10	
23	Wireway Cover, 66.41	036124	1	
24	Hanger Weldment, Short	042661	3	
25	Wireway Cover, 40.05	036122	1	
26	Wireway/Tray Weldment, 40.05	036130	1	
27	<b>CABLE CARRIER PARTS</b> ( <a href="#">See Section 7.23</a> )			

<sup>1</sup> Toe roller sensors removed Rev. A6.00.

## 7.22 Wireway

LT300

Rev. A1.00 - A4.00

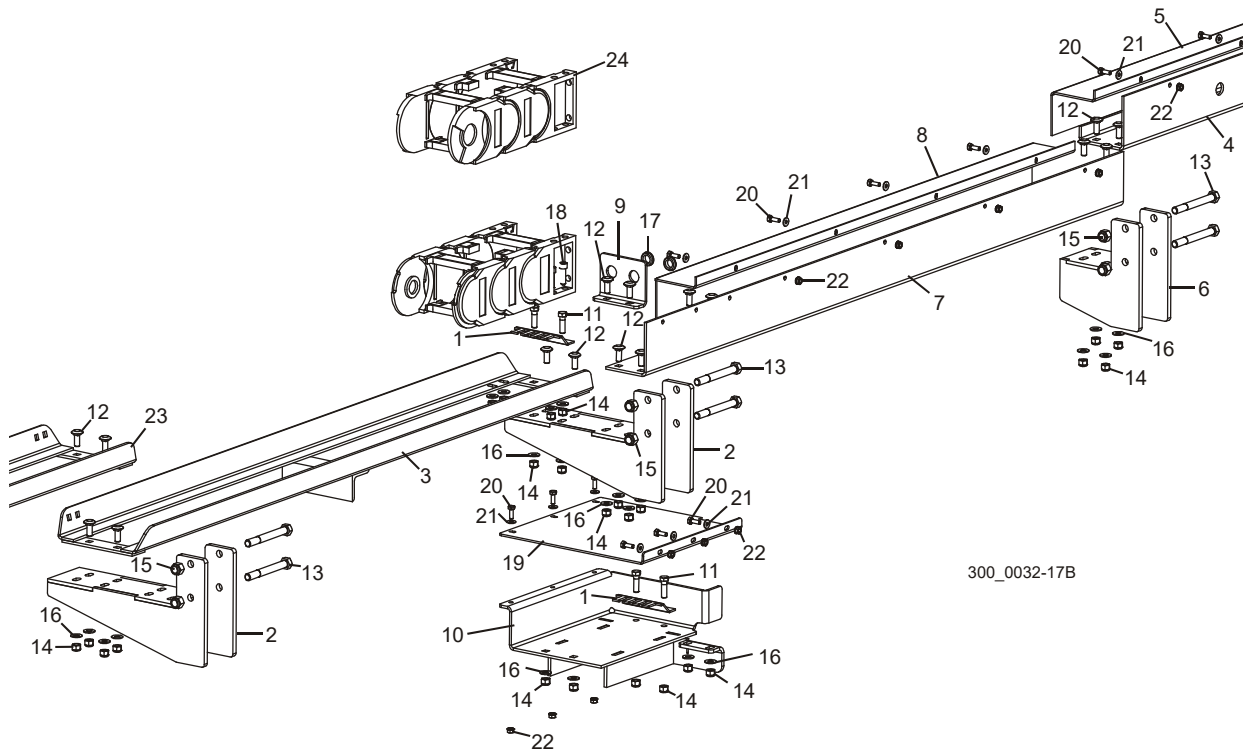

REF	DESCRIPTION (◆ Indicates Parts Available In Assemblies Only)	PART #	QTY.
	<b>WIREWAY ASSEMBLY, LT300</b>	042660	1
1	Plate, Conduit Clamp	023604	2
2	Hanger Weldment, Long Wireway	042115	3
3	Tray Weldment, 54 13/16" Cable Carrier	042833 <sup>1</sup>	1
4	Channel, Long Wireway Base	042119	1
5	Channel, Long Wireway Top	042120	1
6	Hanger Weldment, Short Wireway	042661	3
7	Channel, Short Wireway Base	042664	1
8	Channel, Short Wireway Top	042665	1
9	Plate, Short Wireway End Cap	042666	1
10	Box Weldment, Wireway Junction	042669	1
11	Bolt, 3/8-16 x 1 1/4" Hex Head Grade 5	F05007-123	4
12	Bolt, 3/8-16 x 1" Carriage Head Grade 5	F05007-165	22
13	Bolt, 1/2-13 x 4 1/2 Hex Head Grade 5	F05008-35	12
14	Nut, 3/8-16 Nylon Lock	F05010-10	30
15	Nut, 1/2-13 Nylon Lock	F05010-8	12
16	Washer, 3/8" SAE Flat	F05011-3	28

17	Grommet, 5/8" ID Rubber	P11764	3	
18	Bolt, 3/8-16 x 1 1/4" Hex Head Full Thread	F05007-150	4	
19	Cover, Wireway Box	042668	1	
20	Bolt, 1/4-20 x 3/4 Hex Head Full Thread	F05005-1	17	
21	Washer, 1/4" SAE Flat	F05011-11	17	
22	Nut, 1/4-20 Self-Locking	F05010-9	17	
23	Tray Weldment, 72 3/16" Cable Carrier	042836 <sup>1</sup>	1	
24	<b>CABLE CARRIER PARTS</b> ( <a href="#">See Section 7.25</a> )			

<sup>1</sup> Tray weldments 042833 and 042836 replace tray 014116 originally supplied prior to Rev. A3.00. Longer tray assembly provides additional support for cable carrier.

## 7.23 Cable Carrier

LT300  
LT300

Rev. A7.00 - B3.02  
Rev. B4.00+ (without Pantograph Cable Boom)

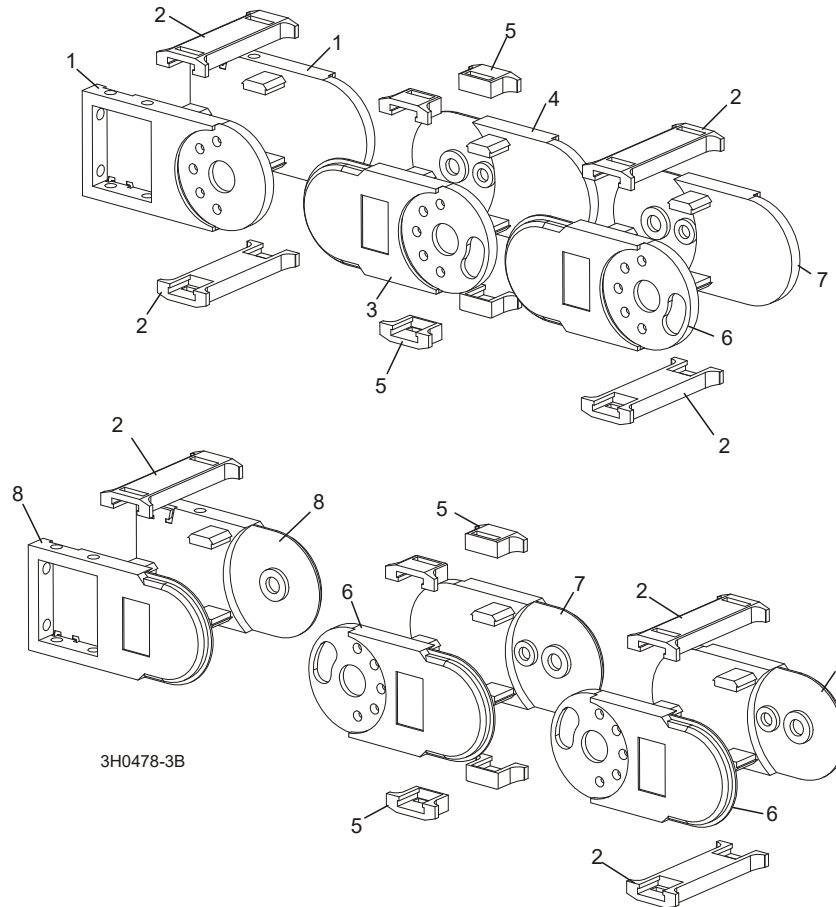

REF	DESCRIPTION (◆ Indicates Parts Available In Assemblies Only)	PART #	QTY.
	<b>CARRIER CABLE, 4140-11-150AA X 46 LINKS LT300</b>	036452 <sup>1</sup>	1
1	Link, Nylon Chain Top Mount	023612-3	2
2	Brace, Nylon Chain Long Cross	023612-4	46
3	Link, Nylon Chain Right Modified	036219-1 <sup>2</sup>	1
4	Link, Nylon Chain Left Modified	036220-1 <sup>2</sup>	1
5	Brace, Nylon Chain Short Cross	023612-5	92
6	Link, Nylon Chain Right Side #4040AA	036219 <sup>2</sup>	45
7	Link, Nylon Chain Left Side #4040AA	036220 <sup>2</sup>	45
8	Link, Nylon Chain Bottom Mount	023612-9	2

<sup>1</sup> Cable Carrier supplied in kit 006806 Rev. B4.00+ instead of Pantograph for customers with space constraints.

<sup>2</sup> Use 036219-1 (4040.01.150.AX) & 036220-1 (4040.02.150.AX) instead of 036219 & 036220 at top link position. Tab removed to allow assembly to top mount links plates (5/07).



## 7.24 Cable Carrier

LT300

Rev. A5.00 - A6.01

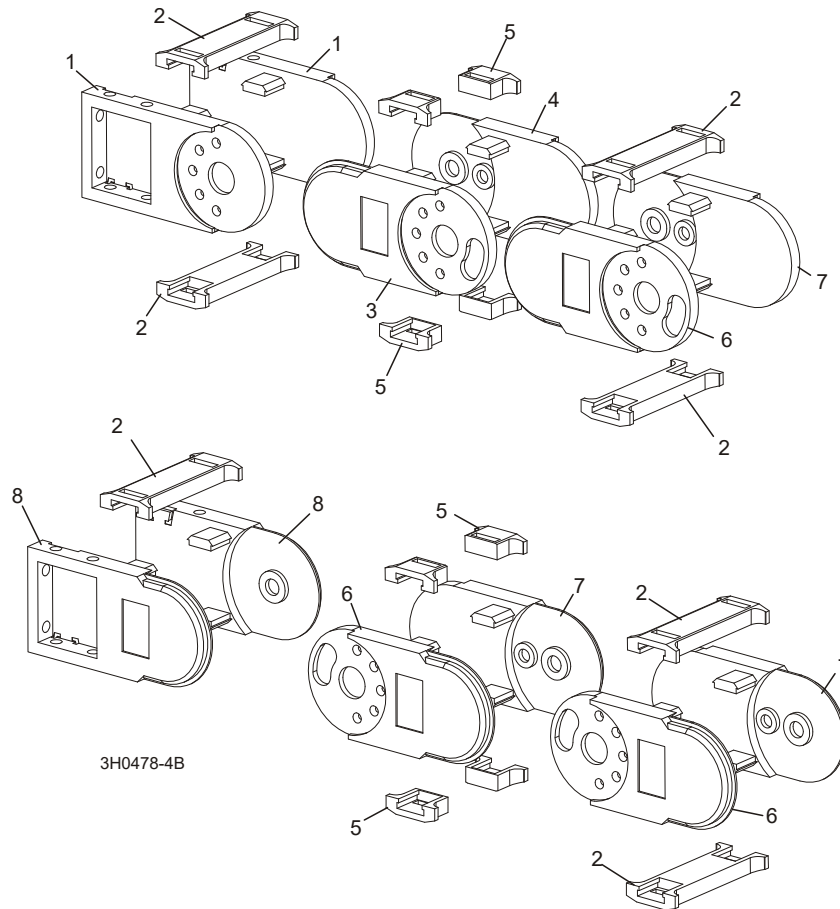

REF	DESCRIPTION (◆ Indicates Parts Available In Assemblies Only)	PART #	QTY.
	<b>CARRIER CABLE, 26' LT300</b>	036170	1
1	Link, Nylon Chain Top Mount	023612-3	2
2	Brace, Nylon Chain Long Cross	023612-4	60
3	Link, Nylon Chain Right Modified	036219-1 <sup>1</sup>	1
4	Link, Nylon Chain Left Modified	036220-1 <sup>1</sup>	1
5	Brace, Nylon Chain Short Cross	023612-5	120
6	Link, Nylon Chain Right Side #4040AA	036219 <sup>1</sup>	59
7	Link, Nylon Chain Left Side #4040AA	036220 <sup>1</sup>	59
8	Link, Nylon Chain Bottom Mount	023612-9	2

<sup>1</sup> Use 036219-1 (4040.01.150.AX) & 036220-1 (4040.02.150.AX) instead of 036219 & 036220 at top link position. Tab removed to allow assembly to top mount links plates (5/07).

## 7.25 Cable Carrier

LT300

Rev. A1.00 - A4.00

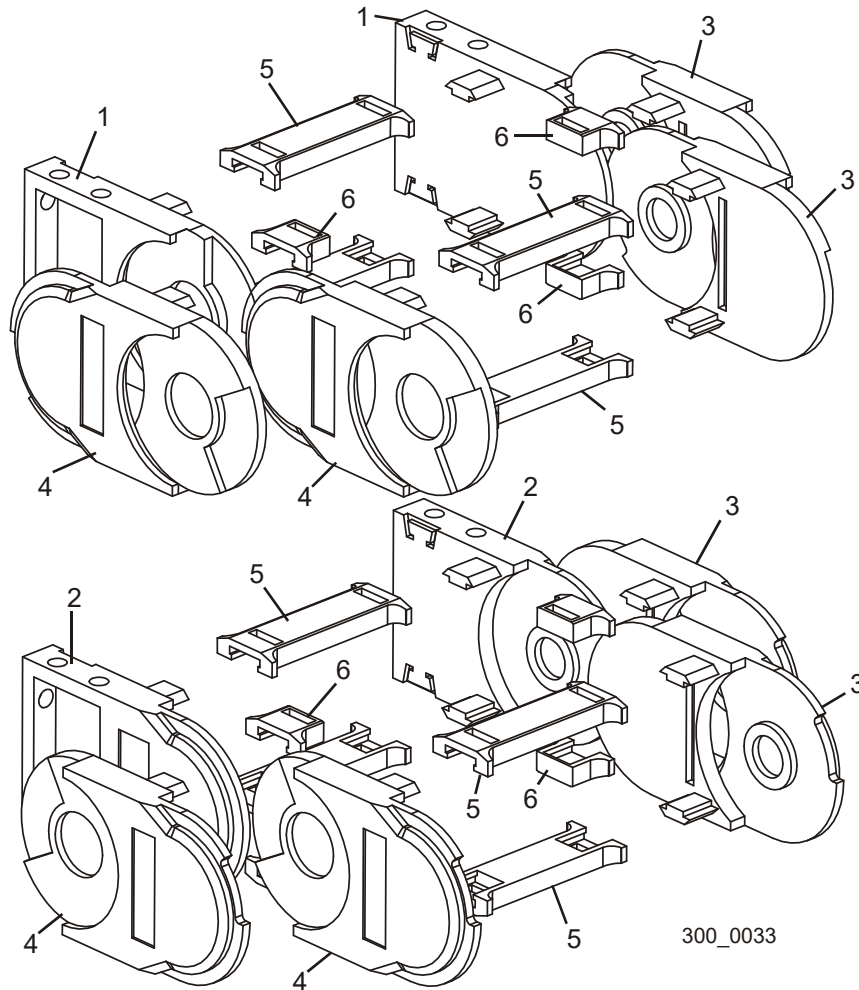

REF	DESCRIPTION (◆ Indicates Parts Available In Assemblies Only)	PART #	QTY.	
	<b>CABLE CARRIER, LT300 #5050</b>	042343 <sup>1</sup>	1	◆
1	Link, 5050 Cable Carrier Top Mount	042711	2	
2	Link, 5050 Cable Carrier Bottom Mount	042710	2	
3	Link, 5050 Cable Carrier Left Side	042719		
4	Link, 5050 Cable Carrier Right Side	042718		
5	Brace, Long Cross Link	023612-4		
6	Brace, Short Cross Link	023612-5		

<sup>1</sup> Cabel Carrier 042343 no longer available. Use kit 025901 to retrofit cable carrier to #4040 style cable carrier to reduce sawdust buildup. [See Section 7.24](#) for component service parts of #4040 style cable carrier.

## SECTION 8 HYDRAULICS

### 8.1 Hydraulic Log Loader Option

LT300

Rev. B1.00+

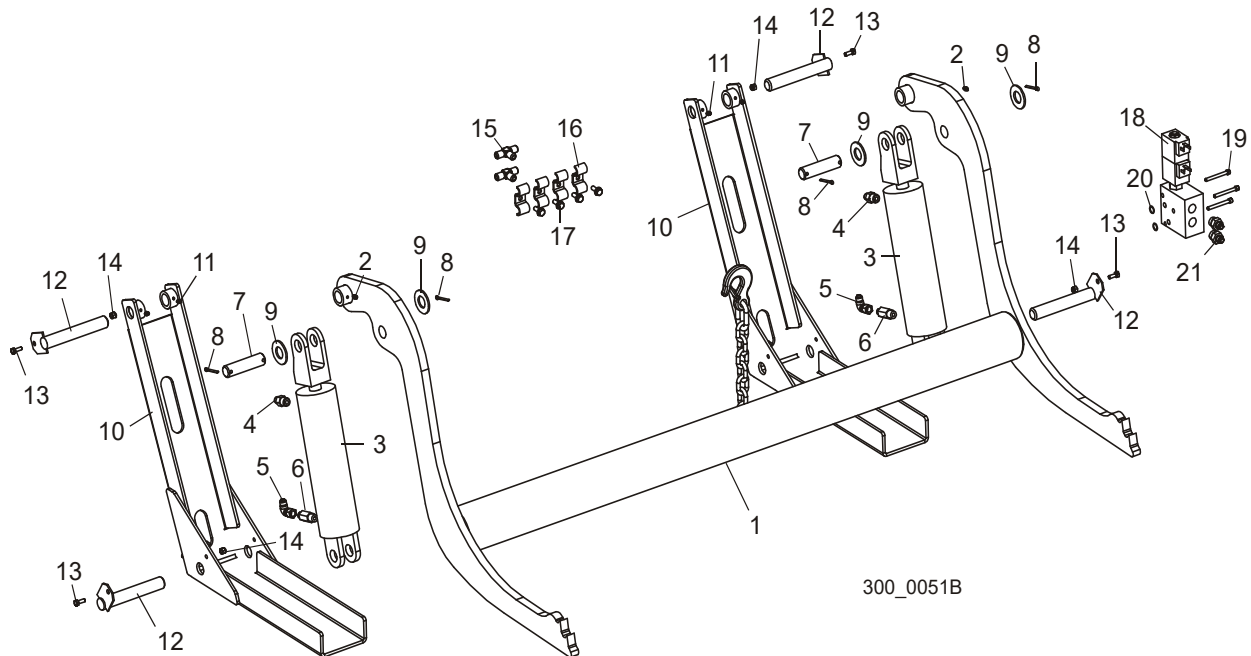

REF	DESCRIPTION (◆ Indicates Parts Available In Assemblies Only)	PART #	QTY.
	<b>ARM ASSEMBLY, HYDRAULIC LOG LOADER</b>	035613	1
1	Arm Weldment, Hydraulic Log Loader	036416-1	1
2	Fitting, 3/16" Straight Grease	P04107	2
	Cylinder Assembly, 3" x 8" x 3/8" NPT 9.5GPM Hydraulic Log Loader	074401 <sup>1</sup>	2
3	Cylinder, 8" X 3" Hydraulic (3/8" NPT Ports)	042754	1
	Seal Kit, 8" x 3" Hydraulic Cylinder	P12956	1
4	Fitting, 3/8" NPT x 3/8" JIC Male Connector	016819	1
5	Fitting, 3/8" JIC 90° Swivel Elbow	042756	1
6	Fuse, 9.5GPM Velocity	074400 <sup>1</sup>	1
7	Pin, Loading Arm Cylinder Mount	S09251	2
8	Pin, 3/16" X 1 1/2" Cotter	F05012-23	4
9	Washer, 1" SAE Flat	F05011-28	4
10	Channel, Hydraulic Log Loading Foot	W09444	2
11	Fitting, 3/16" Grease	P04107	2
12	Pin, Loading Arm Mount	W09446	4
13	Bolt, 1/4-20 x 3/4" Hex Head Full Thread	F05005-1	4
14	Nut, 1/4-20 Hex Lock	F05010-69	4
15	Fitting, 3/8" JIC T	015487	2
16	Clamp, 3/8" Hose	016041	4

## 8

## Hydraulics

### Hydraulic Log Loader Option

17	Bolt, 5/16-18 x 3/4" Self-Tapping Hex	F05015-30	4	
	Hose Kit, Log Loader Option ( <a href="#">See Section 8.22</a> for hose detail)	036552	1	
	Valve Assembly, Hydraulic Log Loader	036824	1	
18	Valve, 24V Hydraulic Add-On 4-Way Closed	025827 <sup>2</sup>	1	
	Valve, Hi-Flow Floating Center Hydraulic	045820 <sup>3</sup>	1	
	Valve, 4-Way Hydraulic	051556 <sup>3</sup>	1	
	Coil, 24V Hydraulic #CAP-024D	051558	2	
19	Screw, 1/4-20 x 2 1/4" Socket Head	F05005-170	3	
20	O-Ring, 1/16" Dia. x 5/8" OD	036808	2	
21	Fitting, #8 SAE x #6 JIC	P12703	2	

<sup>1</sup> Cylinder Assembly 074401 with 9.5GPM velocity fuse 074400 replaces Cylinder Assembly 038735 with 6.5GPM velocity fuse 038734 to improve hydraulic loading arm operation (6/14). Cylinder Assembly 038735 with 6.5GPM velocity fuse 038734 replaced Cylinder Assembly 017645 with 6.0GPM velocity fuse 042755 to maintain consistency with LT70 model sawmill (Rev. B1.00).

<sup>2</sup> Replaces 036724 valve used from 12/10 to 5/14. 036724 replaced 036733 check valve used prior to 12/10.

<sup>3</sup> Use 045820 to service Valve 036734 supplied after 12/10. Use 051556 to service 036733 valve supplied prior to 12/10.

## 8.2 Hydraulic Log Loader Option <sup>1</sup>

LT300

Rev. A3.00 - A9.06

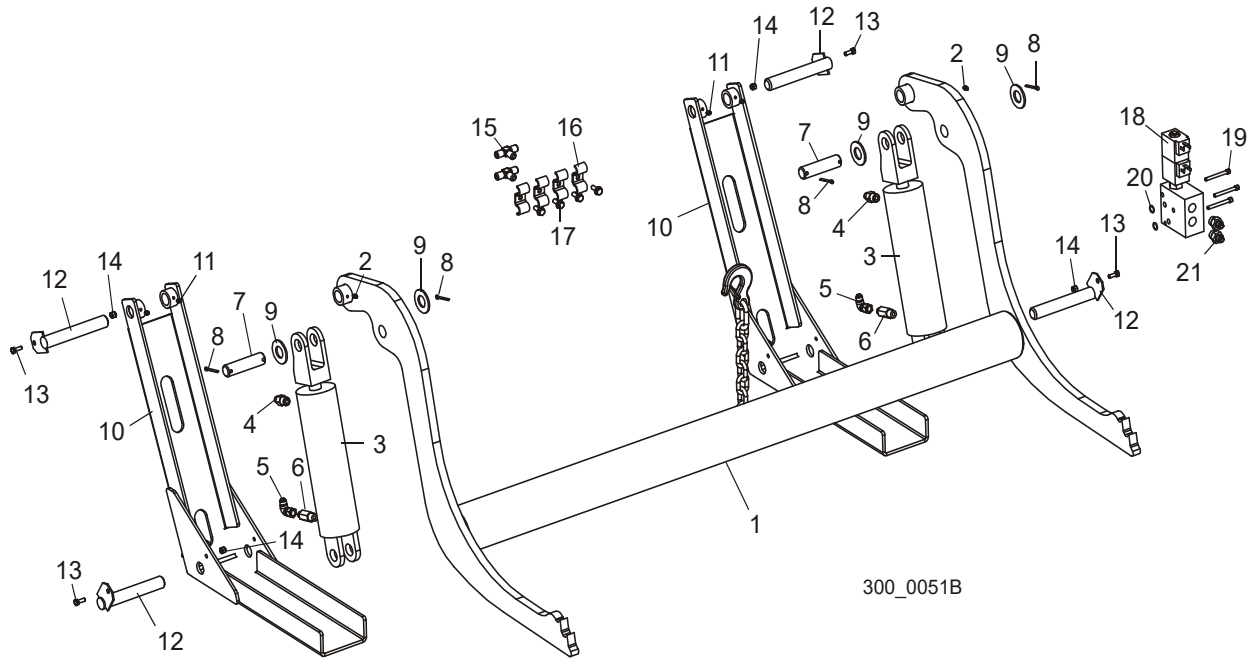

REF	DESCRIPTION (◆ Indicates Parts Available In Assemblies Only)	PART #	QTY.
	<b>ARM ASSEMBLY, HYDRAULIC LOG LOADER</b>	035613 <sup>1</sup>	1
1	Arm Weldment, Hydraulic Log Loader	036416-1 <sup>2</sup>	1
2	Fitting, 3/16" Straight Grease	P04107	2
3	Cylinder Assembly, Hydraulic Log Loader	017645 <sup>1</sup>	2
	Cylinder, 8" X 3" Hydraulic (3/8" NPT Ports)	042754 <sup>1</sup>	1
	Seal Kit, 8" x 3" Hydraulic Cylinder	P12956	1
4	Fitting, 3/8" NPT x 3/8" JIC Male Connector	016819 <sup>1</sup>	1
5	Fitting, 3/8" JIC 90° Swivel Elbow	042756 <sup>1</sup>	1
6	Fitting, 3/8NPT 6.5GPM Velocity Fuse	042755 <sup>1</sup>	1
7	Pin, Loading Arm Cylinder Mount	S09251	2
8	Pin, 3/16" X 1 1/2" Cotter	F05012-23	4
9	Washer, 1" SAE Flat	F05011-28	4
10	Channel, Hydraulic Log Loading Foot	W09444-1	2
11	Fitting, 3/16" Grease	P04107	2
12	Pin, Loading Arm Mount	W09446	4
13	Bolt, 1/4-20 x 3/4" Hex Head Full Thread	F05005-1	4
14	Nut, 1/4-20 Hex Lock	F05010-69	4

<sup>1</sup> Loading arms made optional with Rev. A3.00. Hoses supplied with option Rev. A7.00

## 8

## Hydraulics

### Hydraulic Log Loader Option

15	Fitting, 3/8" JIC T	015487	2	
16	Clamp, 3/8" Hose	016041	4	
17	Bolt, 5/16-18 x 3/4" Self-Tapping Hex	F05015-30	4	
	Hose Kit, Log Loader Option ( <a href="#">See Section 8.22</a> for hose detail)	036552	1	
	Valve Assembly, LT300 Loader	036824 <sup>3</sup>	1	
18	Valve, 24V Hydraulic Add-On PO Check	036734 <sup>4</sup>	1	
	Valve, Hi-Flow Floating Center Hydraulic	045820 <sup>5</sup>	1	
	Valve, 4-Way Hydraulic	051556 <sup>5</sup>	1	
	Coil, 24V Hydraulic #CAP-024D	051558	2	
19	Screw, 1/4-20 x 2 1/4" Socket Head	F05005-170	3	
20	O-Ring, 1/16" Dia. x 5/8" OD	036808	2	
21	Fitting, #8 SAE x #6 JIC	P12703	2	

<sup>1</sup> Loader Arm Assembly 035613 updated with hydraulic cylinders with 3/8" NPT ports and 3/8" fitting to accommodate 6 GPM velocity fuses (Rev. A3.00). 6 GPM velocity fuses match the flow of the LT300 hydraulic system and reduce the possibility of the loading arms locking up in the downward direction. [See Section 8.3](#) for previous revision parts.

<sup>2</sup> Loading Arm Weldment 036416-1 replaces W11805 originally supplied prior to Rev. A7.00. Redesigned arm provides easier loading of logs onto arm.

<sup>3</sup> Valve for Log Loader Option no longer supplied on LT300 (Rev. A9.00). Loader Valve Assembly 036824 added to Log Loader Option.

<sup>4</sup> Replaces 036733 check valve used prior to 12/10.

<sup>5</sup> Use 045820 to service Valve 036734 supplied after 12/10. Use 051556 to service 036733 valve supplied prior to 12/10.

## 8.3 Hydraulic Log Loader

LT300

Rev. A1.00 - A2.01

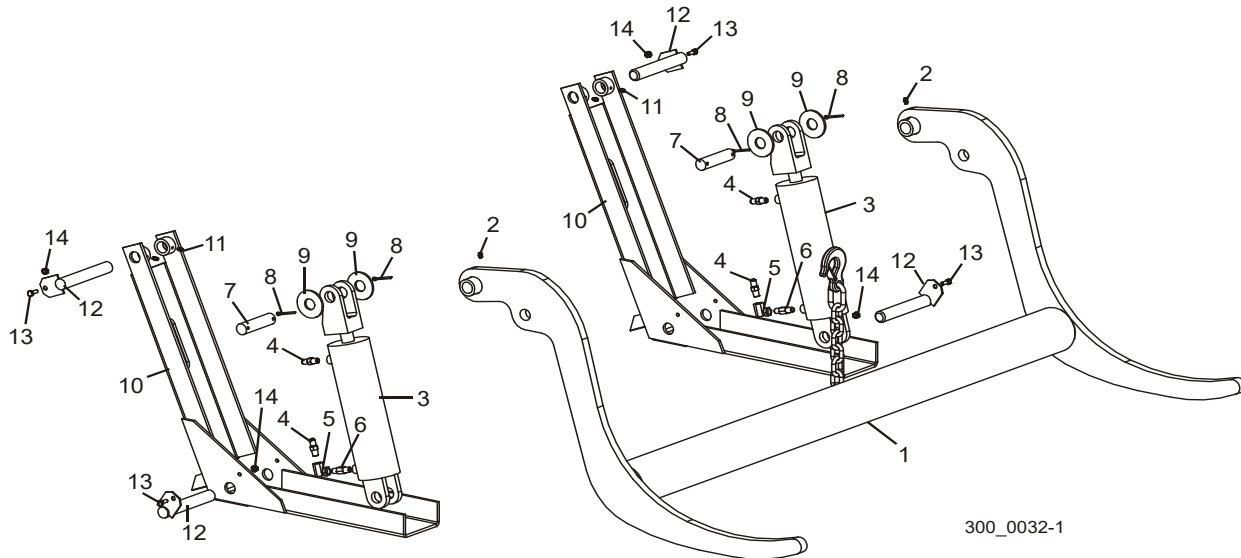

REF	DESCRIPTION (◆ Indicates Parts Available In Assemblies Only)	PART #	QTY.
	<b>ARM ASSEMBLY, HYDRAULIC LOG LOADER</b>	035613 <sup>1</sup>	1
1	Arm Weldment, Hydraulic Log Loader	W11805	1
2	Fitting, 3/16" Straight Grease	P04107	2
	Cylinder Assembly, Hydraulic Log Loader	A09284 <sup>1</sup>	2 ◆
3	Cylinder, 8" X 3" Hydraulic	P12847 <sup>1</sup>	1
	Seal Kit, 8" x 3" Hydraulic Cylinder	P12956	1
4	Fitting, C5205x4x4 Male Connector	P09143 <sup>1</sup>	2
5	Fitting, 0455x4x4 90° Swivel Elbow	P12199 <sup>1</sup>	1
	Fitting Kit, 1/4NPT 4.0GPM Velocity Fuse	015832	1
6	Fitting, 1/4NPT 4.0GPM Velocity Fuse	015750 <sup>1</sup>	2 ◆
	Instruction Sheet, Velocity Fuse Replacement	015832-255	1
7	Pin, Loading Arm Cylinder Mount	S09251	2
8	Pin, 3/16" X 1 1/2" Cotter	F05012-23	4
9	Washer, 1" SAE Flat	F05011-28	4
10	Channel, Hydraulic Log Loading Foot	W09444	2
11	Fitting, 3/16" Grease	P04107	2
12	Pin, Loading Arm Mount	W09446	4
13	Bolt, 1/4-20 x 3/4" Hex Head Full Thread	F05005-1	4
14	Nut, 1/4-20 Hex Lock	F05010-69	4

<sup>1</sup> Hydraulic cylinders and fittings replaced to accommodate 6GPM velocity fuses (Rev. A3.00). [See Section 8.2.](#)

### 8.4 Hydraulic Side Supports

[See Section 8.5](#) for optional middle side support.

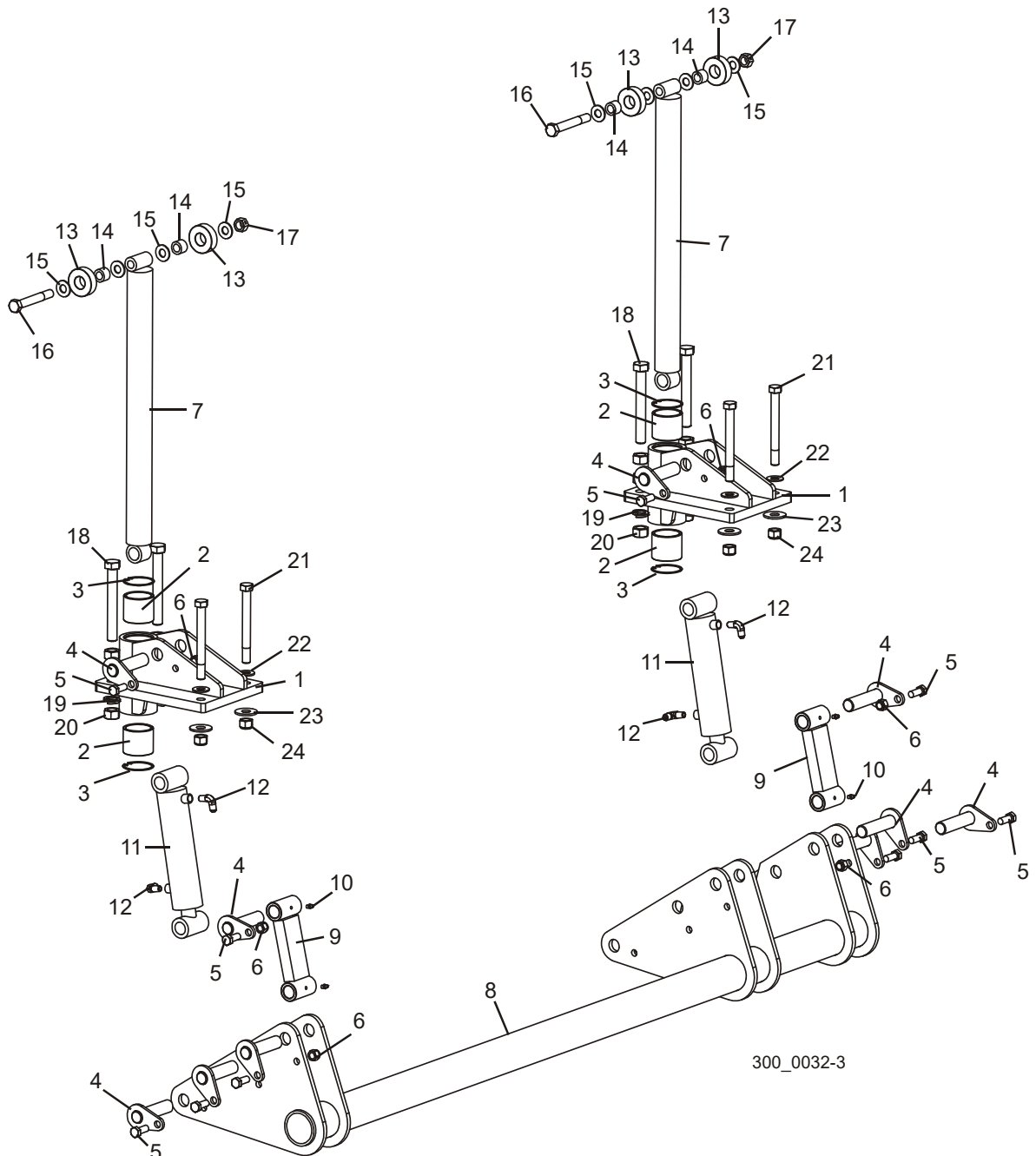

REF	DESCRIPTION (◆ Indicates Parts Available In Assemblies Only)	PART #	QTY.
	<b>SUPPORT ASSEMBLY, HYDRAULIC LOG SIDE</b>	042263	1
1	Bracket Weldment, Side Support Mount	042233	2
2	Bushing, Side Support	042262	4



3	Ring, 62mm DIN #472 Inside Retaining	F04254-12	4	
4	Pin Weldment, Side Support	042232	10	
5	Bolt, 1/2-13 x 1 1/4" Hex Head Grade 5	F05008-37	10	
6	Nut, 1/2-13 Hex Nylon Lock	F05010-8	10	
7	Rod Weldment, Side Support	042234	2	
8	Tube Weldment, Side Support Torque	042231	1	
9	Link Weldment, Side Support	042230	2	
10	Fitting, 1/4-28 Grease	P05060	4	
11	Cylinder, 2" x 6" Side Support	035625	2	
	Seal Kit, 2x6 Hydraulic Cylinder	003812	1	
12	Fitting, 3/8" JIC x 1/4" NPT 90° Elbow	015491	4	
	Roller Assembly, Side Support	035629	2	
13	Roller, Side Support	016561	2	
14	Bushing, 5/8" ID x 3/4" OD x 1" Long Bronze	016560	2	
15	Washer, 5/8" SAE Flat	F05011-5	4	
16	Bolt, 5/8-11 x 4 1/2" Hex Head Grade 5	F05009-10	1	
17	Nut, 5/8-11 Hex Lock	F05010-4	1	
18	Bolt, 3/4-10 x 6" Hex Head Full Thread	F05009-43	4	
19	Washer, 3/4" Split Lock	F05011-6	4	
20	Nut, 3/4-10 Hex	F05010-7	12	
21	Bolt, 5/8-11 x 6" Hex Head Grade 5	F05009-22	4	
22	Washer, 5/8" SAE Flat	F05011-5	4	
23	Washer, 5/8" Standard Flat	F05011-40	4	
24	Nut, 5/8-11 Hex Nylon Lock	F05010-34	4	

**8.5 Side Support (Optional Middle)**

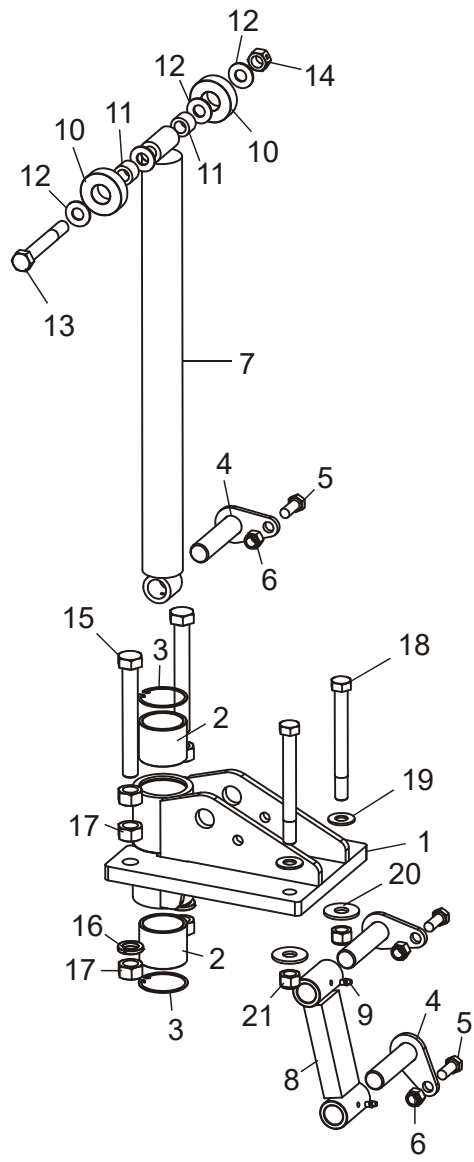

300\_0126

REF	DESCRIPTION (◆ Indicates Parts Available In Assemblies Only)	PART #	QTY.
	<b>SUPPORT ASSEMBLY, OPTIONAL 3RD SIDE</b>	038626	1
1	Bracket Weldment, Side Support Mount	042233	1
2	Bushing, Side Support	042262	2
3	Ring, 62mm DIN #472 Inside Retaining	F04254-12	2
4	Pin Weldment, Side Support	042232	3
5	Bolt, 1/2-13 x 1 1/4" Hex Head Grade 5	F05008-37	3
6	Nut, 1/2-13 Hex Nylon Lock	F05010-8	3
7	Rod Weldment, Side Support	042234	1

8	Link Weldment, Side Support	042230	1	
9	Fitting, 1/4-28 Grease	P05060	2	
	Roller Assembly, Side Support	035629	1	
10	Roller, Side Support	016561	2	
11	Bushing, 5/8" ID x 3/4" OD x 1" Long Bronze	016560	2	
12	Washer, 5/8" SAE Flat	F05011-5	4	
13	Bolt, 5/8-11 x 4 1/2" Hex Head Grade 5	F05009-10	1	
14	Nut, 5/8-11 Hex Lock	F05010-4	1	
15	Bolt, 3/4-10 x 6" Hex Head Full Thread	F05009-43	2	
16	Washer, 3/4" Split Lock	F05011-6	2	
17	Nut, 3/4-10 Hex	F05010-7	6	
18	Bolt, 5/8-11 x 6" Hex Head Grade 5	F05009-22	2	
19	Washer, 5/8" SAE Flat	F05011-5	2	
20	Washer, 5/8" Standard Flat	F05011-40	2	
21	Nut, 5/8-11 Hex Nylon Lock	F05010-34	2	

## 8.6 Hydraulic Log Turner

LT300

Rev. B4.00+

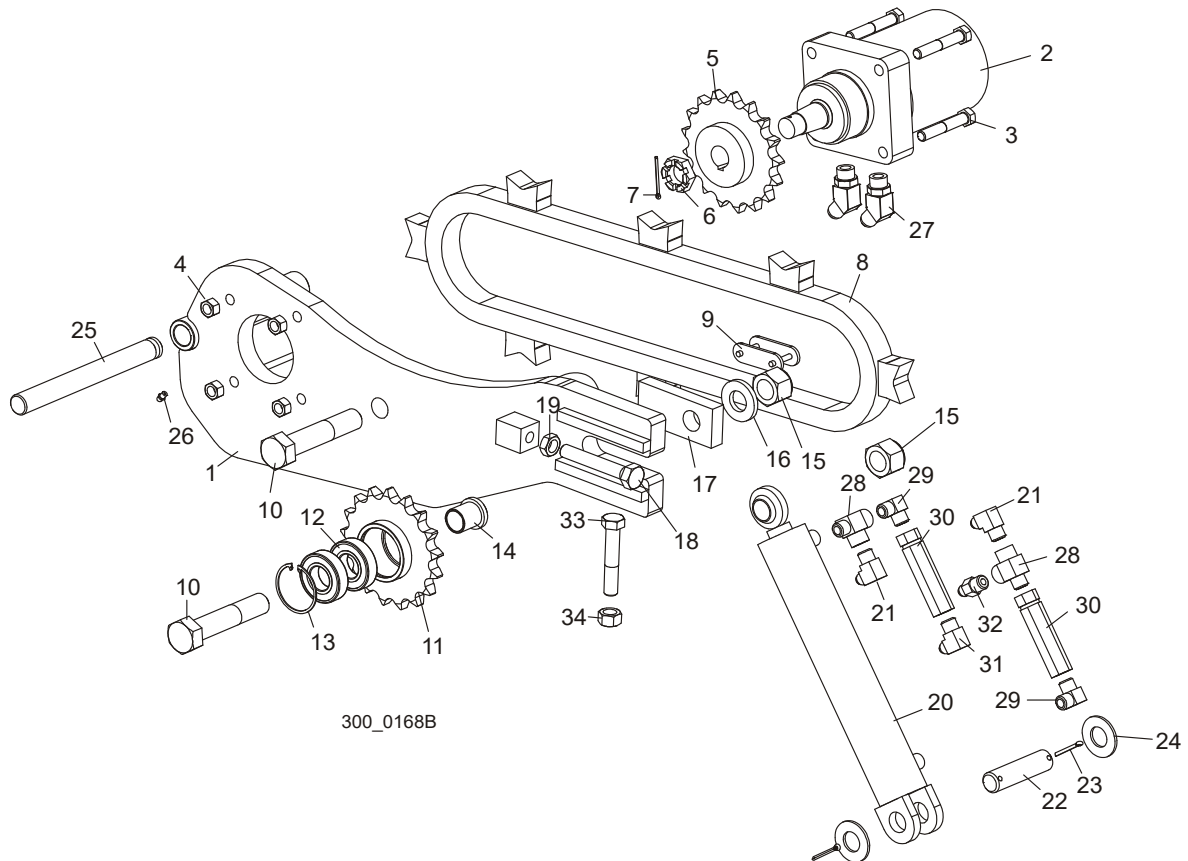

300\_0168B

REF	DESCRIPTION (◆ Indicates Parts Available In Assemblies Only)	PART #	QTY.
	<b>ARM ASSEMBLY, HYDRAULIC LOG TURNER</b>	006802	1
	Arm Assembly, Hydraulic Log Turner	006095	1
1	Arm Weldment, Hydraulic Log Turner	006471	1
2	Motor, Hydraulic Log Turner	007331 <sup>1</sup>	1
	Kit, Seal Rebuild	061427	1
3	Bolt, 1/2-13 x 3" Hex Head Grade 5	F05008-23	4
4	Nut, 1/2-13 Hex Lock	F05010-3	4
5	Sprocket Weldment, Log Turner Drive	042192	1
6	Nut, Hydraulic Motor Castle	018741-2	1
7	Pin, 1/8" x 1 3/4" Cotter	F05012-43	1
8	Chain Weldment, Log Turner	006097	1
9	Link, #2080H Master	016796	1
10	Bolt, 1-8 x 5" Hex Head Grade 8	F05004-132	2
	Sprocket Assembly, Idler	042193	1
11	Sprocket Weldment, Idler	042191	1

12	Bearing, 6206 25 Idler	P11035	2	
13	Ring, 62mm #472 DIN Inside Retaining	F04254-12	1	
14	Spacer, Idler Sprocket	042187	2	
15	Nut, 1-8 Hex Lock	F05010-109	2	
16	Washer, 1" ID x 2" OD x 1/4"	038749	1	
17	Plate, Log Turner Chain Tensioner	042188	1	
18	Bolt, 5/8-11 x 4" Hex Head Full Thread Grade 5	F05009-31	1	
19	Nut, 5/8-11 Hex Jam	F05010-82	1	
20	Cylinder, 2" x 10" Welded Rod End Hydraulic	034267	1	
	Seal Kit, 2x10 Hydraulic Cylinder	003814	1	
21	Fitting, 3/8" NPT x 3/8" JIC 90° Elbow	016820	2	
22	Pin, 1" x 3.88"	S09251	1	
23	Pin, 3/16" x 1 1/2" Cotter	F05012-23	2	
24	Washer, 1" SAE Flat	F05011-28	2	
25	Rod, Grooved Turner Mount	006722	1	
26	Fitting, 1/4-28 Grease	P05060	1	
27	Fitting, #10 SAE x 1/2" JIC 45° Elbow	016807	2	
28	Fitting, 3/8" NPT Male Run T	016822	2	
29	Fitting, 3/8" NPT 90° Elbow	016821	2	
30	Valve, 1000 PSI Sequence	042724	2	
31	Fitting, 3/8" NPT x 3/8" JIC 90° Elbow	016820	1	
32	Fitting, 3/8" NPT x 3/8" JIC Male Connector	016819	1	
33	<b>BOLT, 5/8-18 X 3 1/2" HEX HEAD BOLT FULL THREAD</b>	F05009-16	1	
34	<b>NUT, 5/8-18 HEX</b>	F05010-50	1	

<sup>1</sup> Hydraulic Motor 007331 replaces 018741 originally supplied prior to 6/09. 018741 was changed by the vendor and no longer fits the hole in the log turner arm.

## 8.7 Hydraulic Log Turner

Rev. A2.00 - B3.02

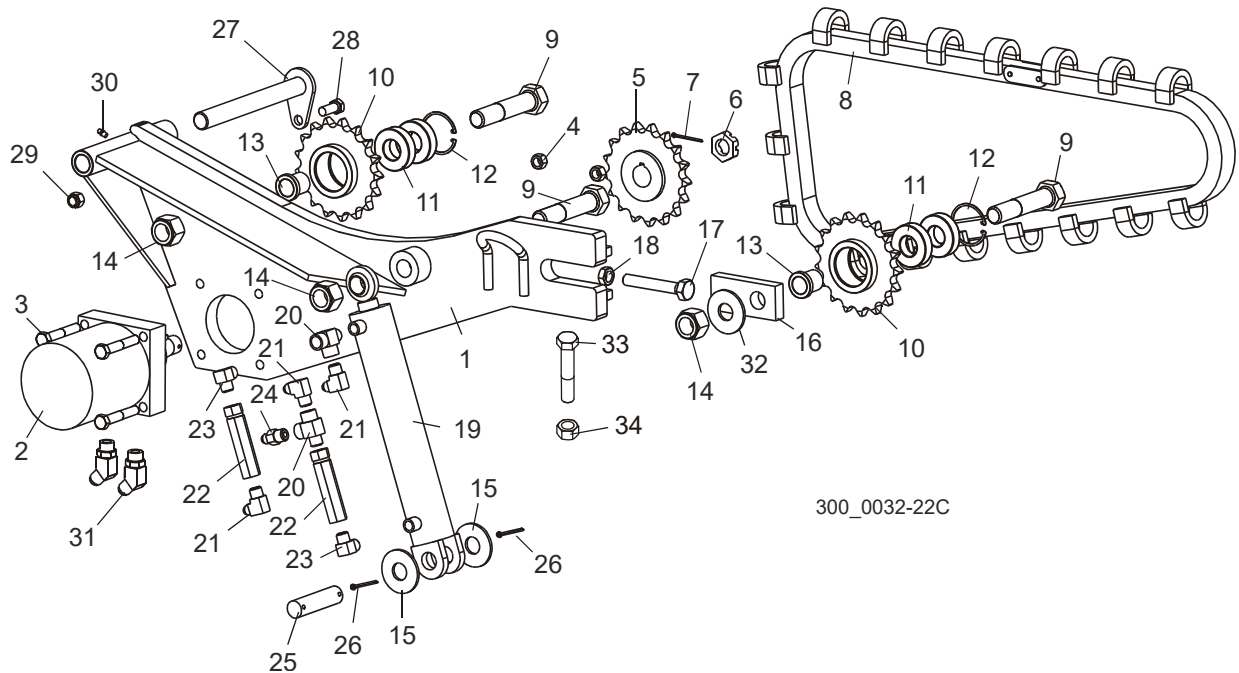

REF	DESCRIPTION (◆ Indicates Parts Available In Assemblies Only)	PART #	QTY.
	<b>ARM ASSEMBLY, HYDRAULIC LOG TURNER</b>	016874	1
1	Arm Weldment, Hydraulic Log Turner	016873	1
2	Motor, Hydraulic Log Turner	007331 <sup>1</sup>	1
	Kit, Seal Rebuild	061427	1
3	Bolt, 1/2-13 x 3" Hex Head Grade 5	F05008-23	4
4	Nut, 1/2-13 Hex Lock	F05010-3	4
5	Sprocket Weldment, Log Turner Drive	042192	1
6	Nut, Hydraulic Motor Castle	018741-2	1
7	Pin, 1/8" x 1 3/4" Cotter	F05012-43	1
8	Chain Weldment, Log Turner	025655 <sup>2</sup>	1
	Cog, Log Turner	042194 <sup>3</sup>	17
	Chain, #2080 Log Turner	042195	1
	Link, #2080H Master	016796	1
9	Bolt, 1-8 x 5" Hex Head Grade 8	F05004-132	3
	Sprocket Assembly, Idler	042193	2
10	Sprocket Weldment, Idler	042191	1
11	Bearing, 6206 25 Idler	P11035	2
12	Ring, 62mm #472 DIN Inside Retaining	F04254-12	1

13	Spacer, Idler Sprocket	042187	2	
14	Nut, 1-8 Hex Lock	F05010-109	3	
15	Washer, 1" SAE Flat	F05011-28	2	
16	Plate, Log Turner Chain Tensioner	042188	1	
17	Bolt, 5/8-11 x 4" Hex Head Full Thread Grade 5	F05009-31	1	
18	Nut, 5/8-11 Hex Jam	F05010-82	1	
19	Cylinder, 2" x 10" Welded Rod End Hydraulic	034267	1	
	Seal Kit, 2x10 Hydraulic Cylinder	003814	1	
20	Fitting, 3/8" NPT Male Run T	016822	2	
21	Fitting, 3/8" NPT x 3/8" JIC 90° Elbow	016820	3	
22	Valve, 1000 PSI Sequence	042724	2	
23	Fitting, 3/8" NPT 90° Elbow	016821	2	
24	Fitting, 3/8" NPT x 3/8" JIC Male Connector	016819	1	
25	Pin, 1" x 3.88"	S09251	1	
26	Pin, 3/16" x 1 1/2" Cotter	F05012-23	2	
27	Pin Weldment, Log Turner Mount	042331	1	
28	Bolt, 1/2-13 x 1 1/4" Hex Head Grade 5	F05008-37	1	
29	Nut, 1/2-13 Hex Nylon Lock	F05010-8	1	
30	Fitting, 1/4-28 Grease	P05060	1	
31	Fitting, #10 SAE x 1/2" JIC 45° Elbow	016807	2	
32	Washer, 1" ID x 2" OD x 1/4" Thick	038749 <sup>4</sup>	1	
33	<b>BOLT, 5/8-18 X 3 1/2" HEX HEAD BOLT FULL THREAD</b>	F05009-16	1	
34	<b>NUT, 5/8-18 HEX</b>	F05010-50	1	

<sup>1</sup> Hydraulic Motor 007331 replaces 018741 originally supplied prior to 6/09.

<sup>2</sup> Turner Chain 025655 replaces original chain 042196 supplied prior to 4/10. New chain provides more aggressive log turning.

<sup>3</sup> Applies to original Turner Chain 042196 only.

<sup>4</sup> Thicker Washer 038749 replaces 1" SAE Washer F05011-28 to prevent washer from pulling into slot when assembly is tightened (Rev. B1.00).

## 8.8 Hydraulic Log Turner

Rev. A1.00 - A1.01

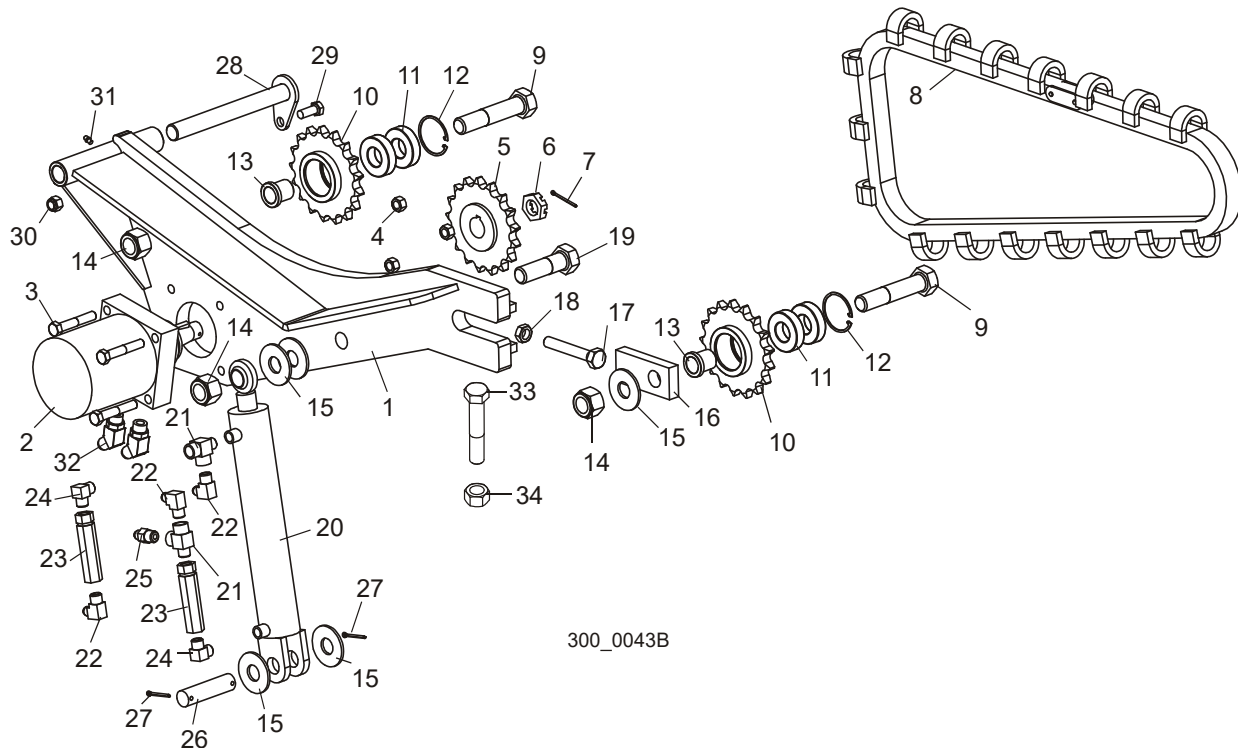

300\_0043B

REF	DESCRIPTION (◆ Indicates Parts Available In Assemblies Only)	PART #	QTY.
	<b>ARM ASSEMBLY, HYDRAULIC LOG TURNER</b>	042190 <sup>1</sup>	1
1	Arm Weldment, Hydraulic Log Turner	042185	1
2	Motor, Hydraulic Log Turner	007331 <sup>2</sup>	1
	Kit, Seal Rebuild	061427	1
3	Bolt, 1/2-13 x 3" Hex Head Grade 5	F05008-23	4
4	Nut, 1/2-13 Hex Lock	F05010-3	4
5	Sprocket Weldment, Log Turner Drive	042192	1
6	Nut, Hydraulic Motor Castle	018741-2	1
7	Pin, 1/8" x 1 3/4" Cotter	F05012-43	1
8	Chain Weldment, Log Turner	025655 <sup>3</sup>	1
	Cog, Log Turner	042194 <sup>4</sup>	17
	Chain, #2080 Log Turner	042195	1
	Link, #2080H Master	016796	1
9	Bolt, 1-8 x 5" Hex Head Grade 8	F05004-132	2
	Sprocket Assembly, Idler	042193	2
10	Sprocket Weldment, Idler	042191	1
11	Bearing, 6206 25 Idler	P11035	2



12	Ring, 62mm #472 DIN Inside Retaining	F04254-12	1	
13	Spacer, Idler Sprocket	042187	2	
14	Nut, 1-8 Hex Lock	F05010-109	3	
15	Washer, 1" SAE Flat	F05011-28	5	
16	Plate, Log Turner Chain Tensioner	042188	1	
17	Bolt, 5/8-11 x 4" Hex Head Full Thread Grade 5	F05009-31	1	
18	Nut, 5/8-11 Hex Jam	F05010-82	1	
19	Bolt, 1-8 x 3 1/2" Hex Head Grade 5	F05009-50	1	
20	Cylinder, 2" x 10" Welded Rod End Hydraulic	035624	1	
	Seal Kit, 2x10 Hydraulic Cylinder	003813	1	
21	Fitting, 3/8" NPT Male Run T	016822	2	
22	Fitting, 3/8" NPT x 3/8" JIC 90° Elbow	016820	3	
23	Valve, 700 PSI Sequence	015484 <sup>5</sup>	2	
24	Fitting, 3/8" NPT 90° Elbow	016821	2	
25	Fitting, 3/8" NPT x 3/8" JIC Male Connector	016819	1	
26	Pin, 1" x 3.88"	S09251	1	
27	Pin, 3/16" x 1 1/2" Cotter	F05012-23	2	
28	Pin Weldment, Log Turner Mount	042331	1	
29	Bolt, 1/2-13 x 1 1/4" Hex Head Grade 5	F05008-37	1	
30	Nut, 1/2-13 Hex Nylon Lock	F05010-8	1	
31	Fitting, 1/4-28 Grease	P05060	1	
32	Fitting, #10 SAE x 1/2" JIC 45° Elbow	016807	2	
33	<b>BOLT, 5/8-18 X 3 1/2" HEX HEAD BOLT FULL THREAD</b>	F05009-16	1	
34	<b>NUT, 5/8-18 HEX</b>	F05010-50	1	

<sup>1</sup> Log Turner Arm Assembly 042190 replaced with assembly 016874 on LT300 Rev. A2.00+ ([See Section 8.7](#)).

<sup>2</sup> Hydraulic Motor 007331 replaces 018741 originally supplied prior to 6/09. 018741 was changed by the vendor and no longer fits the hole in the log turner arm. 018741 MB29-02-08-AABP motor replaced 018181 MB15-02-08 motor to increase turner weight capacity (Rev. A3.00).

<sup>3</sup> Turner Chain 025655 replaces original chain 042196 supplied prior to 4/10. New chain provides more aggressive log turning.

<sup>4</sup> Applies to original Turner Chain 042196 only.

<sup>5</sup> 700 PSI Sequence Valve 015484 replaced with 1000 PSI Sequence Valve 042724 to increase pressure differential and improve turner/side support sequencing (LT300 Rev. A2.00+).

## 8.9 Hydraulic Log Clamp

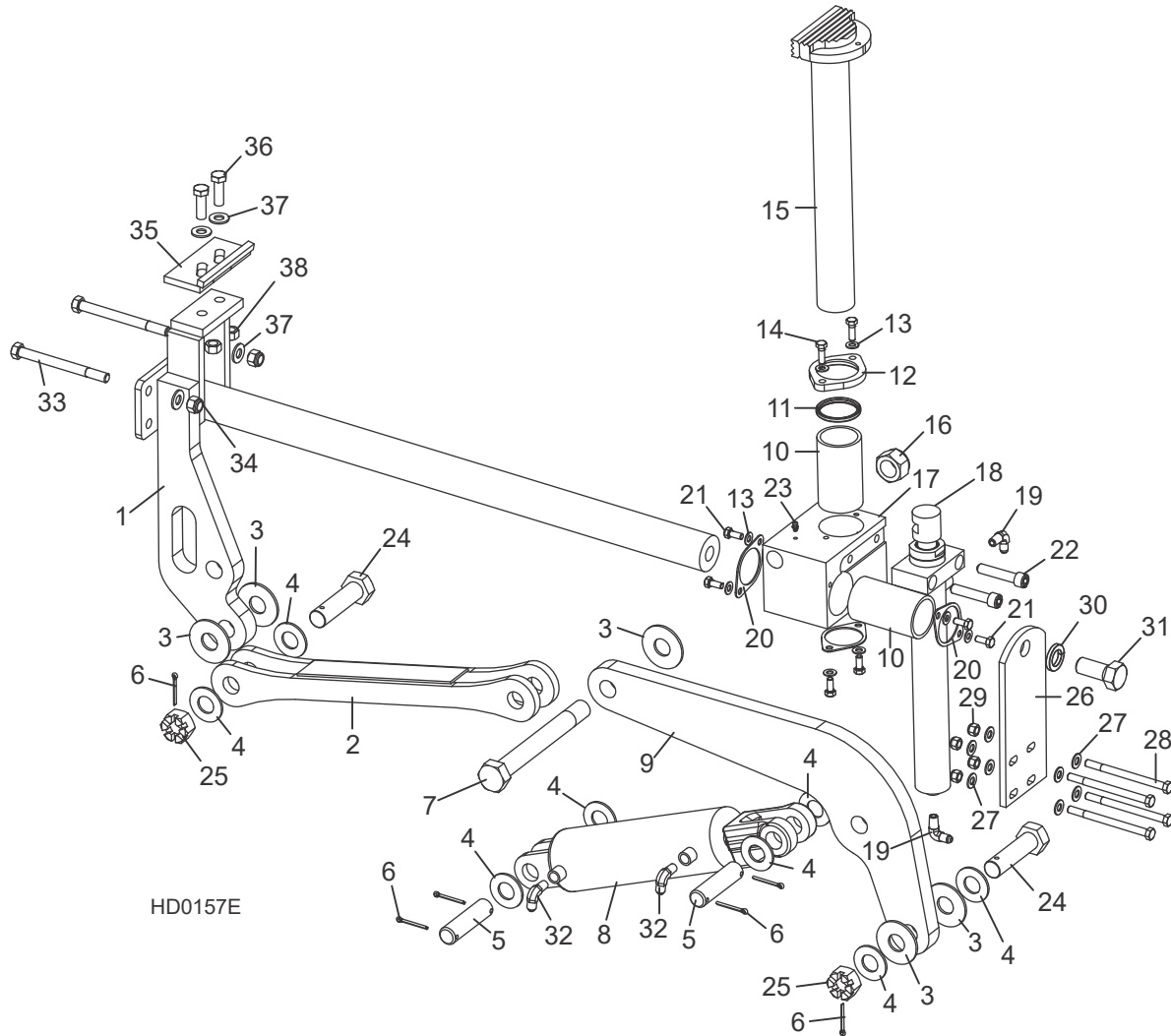

REF	DESCRIPTION (◆ Indicates Parts Available In Assemblies Only)	PART #	QTY.
	<b>CLAMP ASSEMBLY, HYDRAULIC 2-PLANE</b>	017264	1
1	Mount Weldment, Hydraulic Clamp Slide	017265	1
2	Link Weldment, Hydraulic Clamp	017267	1
3	Washer, 1/8" x 2 1/2" Hardened	015057	5
4	Washer, 1" SAE Flat	F05011-28	8
5	Pin, 1" x 3.88"	S09251	2
6	Pin, 3/16" x 1 1/2" Cotter	F05012-23	6
7	Bolt, 1-14 x 8 1/2" Hex Head Grade 8	015049	1
8	Cylinder, 3" x 7" Hydraulic	017275	1
	Seal Kit, Hydraulic Cylinder	P12956	1
9	Arm, Clamp Pivot	017274	1

10	Bushing, Clamp Slide	015088	2	
	Wiper Assembly, Vertical Clamp Rod	017271	1	
11	Wiper, Vertical Clamp Rod	017273	1	
12	Flange, Vertical Clamp Rod Wiper	017272	1	
13	Washer, 5/16" SAE Flat	F05011-17	8	
14	Bolt, 5/16-18 x 1" Hex Head	F05006-1	2	
15	Clamp Weldment, Vertical	015043	1	
16	Nut, 1-14 Nylon Lock	F05010-141	1	
17	Block, Hydraulic Clamp Slide	017270	1	
18	Cylinder Weldment, Vertical Clamp Hydraulic	015050	1	
	Seal Kit, Hydraulic Cylinder	016204	1	
	Instruction Sheet, Vertical Clamp Seal Replacement	016204-1009	1	
19	Fitting, 1/4" NPT x 1/4" JIC Elbow	P09142	2	
20	Retainer, Clamp Bushing	017242	3	
21	Bolt, 5/16-18 x 3/4" Hex Head	F05006-5	6	
22	Bolt, 1/2-13 x 2 1/2" Socket Head	F05008-39	2	
23	Fitting, 3/16" Straight Grease	P04107	1	
24	Bolt, 1-14 x 3 3/4" Hex Head Grade 8 w/Hole	015072	2	
25	Nut, 1-14 Slotted Hex	F05010-163	2	
26	Plate, Log Clamp Mount	015068	1	
27	Washer, 3/8" SAE Flat	F05011-3	8	
28	Bolt, 3/8-16 x 5" Hex Head	F05007-5	4	
29	Nut, 3/8-16 Hex Nylon Lock	F05010-10	4	
30	Washer, 7/8" Split Lock	F05011-46	1	
31	Bolt, 7/8-14 x 2" Hex Head Grade 5	F05014-2	1	
32	Fitting, 1/4" NPT - 3/8" JIC Elbow	015491	2	
33	Bolt, 1/2-13 x 5 1/2" Hex Head Grade 5	F05008-28	2	
34	Nut, 1/2-13 Hex Nylon Lock	F05010-8	2	
	Clamp Stop Kit, Hydraulic Log	K09485	1	
35	Plate, Clamp Stop	W09404	1	
36	Bolt, 1/2-13 X 1 1/2" Hex Head Grade 5	F05008-33	2	
37	Washer, 1/2" SAE Flat	F05011-2	2	
38	Nut, 1/2-13 Hex Lock	F05010-3	2	

### 8.10 Hydraulic Toe Board (Front)

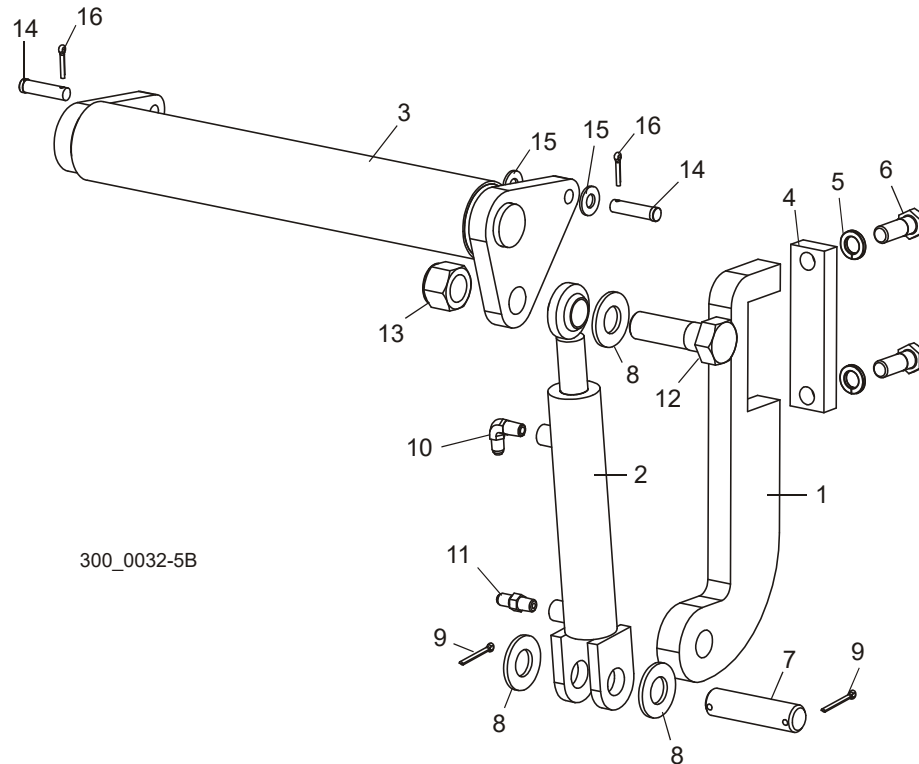

300\_0032-5B

REF	DESCRIPTION (◆ Indicates Parts Available In Assemblies Only)	PART #	QTY.
	<b>TOE BOARD ASSEMBLY, FRONT HYDRAULIC</b>	035640 <sup>1</sup>	1
1	Plate, Hydraulic Toe Board Mount	S13022	1
2	Cylinder, 1 1/2" x 6" Toe Board	014482	1
	Seal Kit, 1 1/2" x 6" Hydraulic Cylinder	014547	1
3	Roller Assembly, Hydraulic Toe Board	074842	1
4	Plate, Toe Board Strap	S13023	1
5	Washer, 5/8" Split Lock	F05011-27	2
6	Bolt, 5/8-11 x 1 3/4" Hex Head	F05009-33	2
7	Pin, 1" x 3.88"	S09251	1
8	Washer, 1" SAE Flat	F05011-28	3
9	Pin, 3/16" x 1 1/2" Cotter	F05012-23	2
10	Fitting, 1/4" NPT x 1/4" JIC 90° Male Elbow	P09142	1
11	Fitting, 1/4" NPT x 1/4" JIC Straight Male	P09143	1
12	Bolt, 1-8 x 3 1/4" Hex Head Grade 5	F05009-51	1
13	Nut, 1-8 Hex Lock	F05010-109	1
14	Pin, 1/2" x 1 3/4" Clevis	F05012-82	2
15	Washer, 1/2" SAE Flat	F05011-2 <sup>2</sup>	2
16	Pin, 1/8" x 3/4" Cotter	F05012-3	2

<sup>1</sup> One assembly removed Rev. A7.00. Not needed.

<sup>2</sup> Two washers removed from frame-side pivot to increase clearance for easier assembly.

### 8.11 Hydraulic Toe Board (Rear)

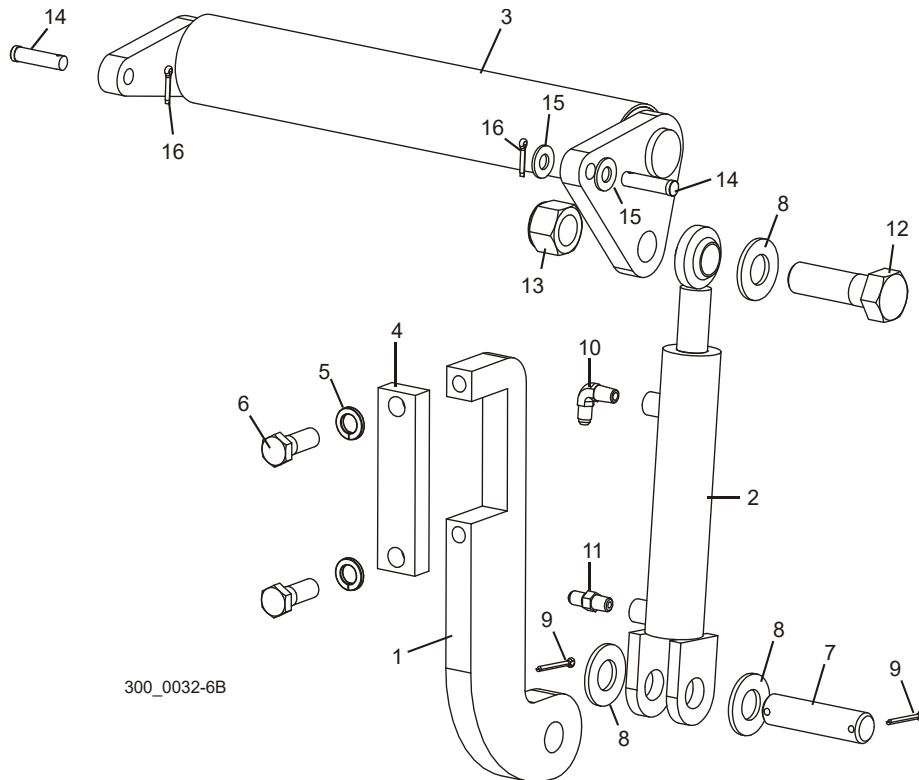

REF	DESCRIPTION (◆ Indicates Parts Available In Assemblies Only)	PART #	QTY.
	<b>TOE BOARD ASSEMBLY, REAR HYDRAULIC</b>	035642	1
1	Plate, Hydraulic Toe Board Mount	S13022	1
2	Cylinder, 1 1/2" x 6" Toe Board	014482	1
	Seal Kit, 1 1/2" x 6" Hydraulic Cylinder	014547	1
3	Roller Assembly, Hydraulic Toe Board	074851	1
4	Plate, Toe Board Strap	S13023	1
5	Washer, 5/8" Split Lock	F05011-27	2
6	Bolt, 5/8-11 x 1 3/4" Hex Head	F05009-33	2
7	Pin, 1" x 3.88"	S09251	1
8	Washer, 1" SAE Flat	F05011-28	3
9	Pin, 3/16" x 1 1/2" Cotter	F05012-23	2
10	Fitting, 1/4" NPT x 1/4" JIC 90° Male Elbow	P09142	1
11	Fitting, 1/4" NPT x 1/4" JIC Straight Male	P09143	1
12	Bolt, 1-8 x 3 1/4" Hex Head Grade 5	F05009-51	1
13	Nut, 1-8 Hex Lock	F05010-109	1
14	Pin, 1/2" x 1 3/4" Clevis	F05012-82	2
15	Washer, 1/2" SAE Flat	F05011-2 <sup>1</sup>	2
16	Pin, 1/8" x 3/4" Cotter	F05012-3	2

<sup>1</sup> Two washers removed from frame-side pivot to increase clearance for easier assembly.

# 8 Hydraulics

## Hydraulic Toe Board (Rear w/Ramp)

### 8.12 Hydraulic Toe Board (Rear w/Ramp)

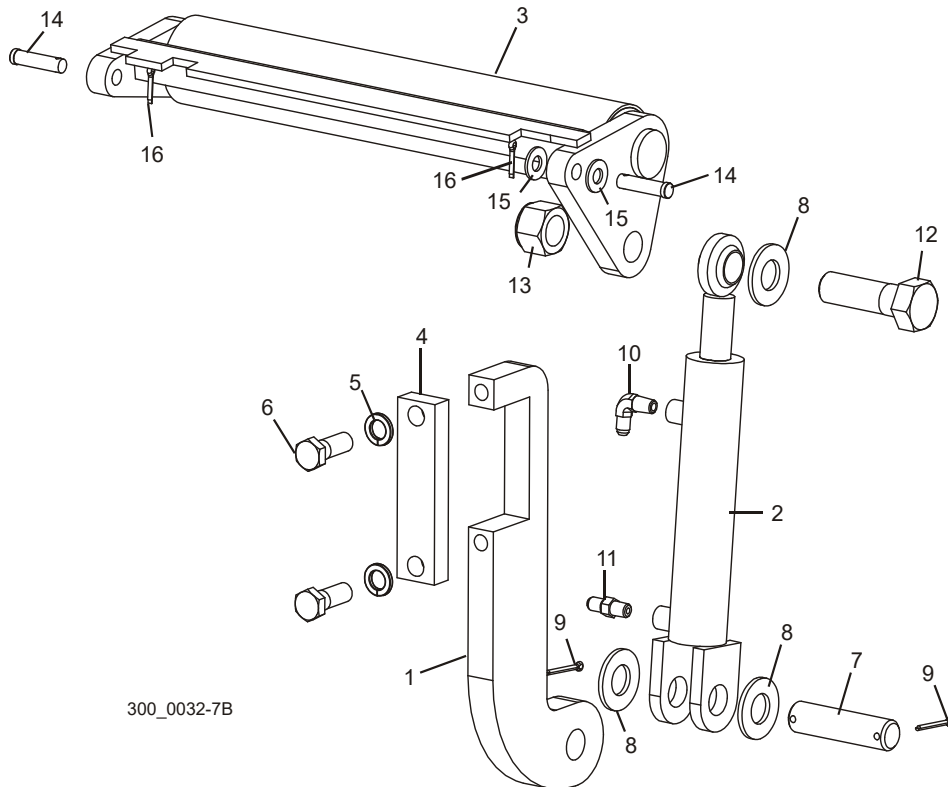

REF	DESCRIPTION (◆ Indicates Parts Available In Assemblies Only)	PART #	QTY.
	<b>TOE BOARD ASSEMBLY, REAR HYDRAULIC W/RAMP</b>	035564	1
1	Plate, Hydraulic Toe Board Mount	S13022	1
2	Cylinder, 1 1/2" x 6" Toe Board	014482	1
	Seal Kit, 1 1/2" x 6" Hydraulic Cylinder	014547	1
3	Roller Assembly, Hydraulic Toe Board (w/Ramp)	074857	1
4	Plate, Toe Board Strap	S13023	1
5	Washer, 5/8" Split Lock	F05011-27	2
6	Bolt, 5/8-11 x 1 3/4" Hex Head	F05009-33	2
7	Pin, 1" x 3.88"	S09251	1
8	Washer, 1" SAE Flat	F05011-28	3
9	Pin, 3/16" x 1 1/2" Cotter	F05012-23	2
10	Fitting, 1/4" NPT x 1/4" JIC 90° Male Elbow	P09142	1
11	Fitting, 1/4" NPT x 1/4" JIC Straight Male	P09143	1
12	Bolt, 1-8 x 3 1/4" Hex Head Grade 5	F05009-51	1
13	Nut, 1-8 Hex Lock	F05010-109	1
14	Pin, 1/2" x 1 3/4" Clevis	F05012-82	2
15	Washer, 1/2" SAE Flat	F05011-2 <sup>1</sup>	2
16	Pin, 1/8" x 3/4" Cotter	F05012-3	2

<sup>1</sup> Two washers removed from frame-side pivot to increase clearance for easier assembly.

## 8.13 Hydraulic Pump & Tank

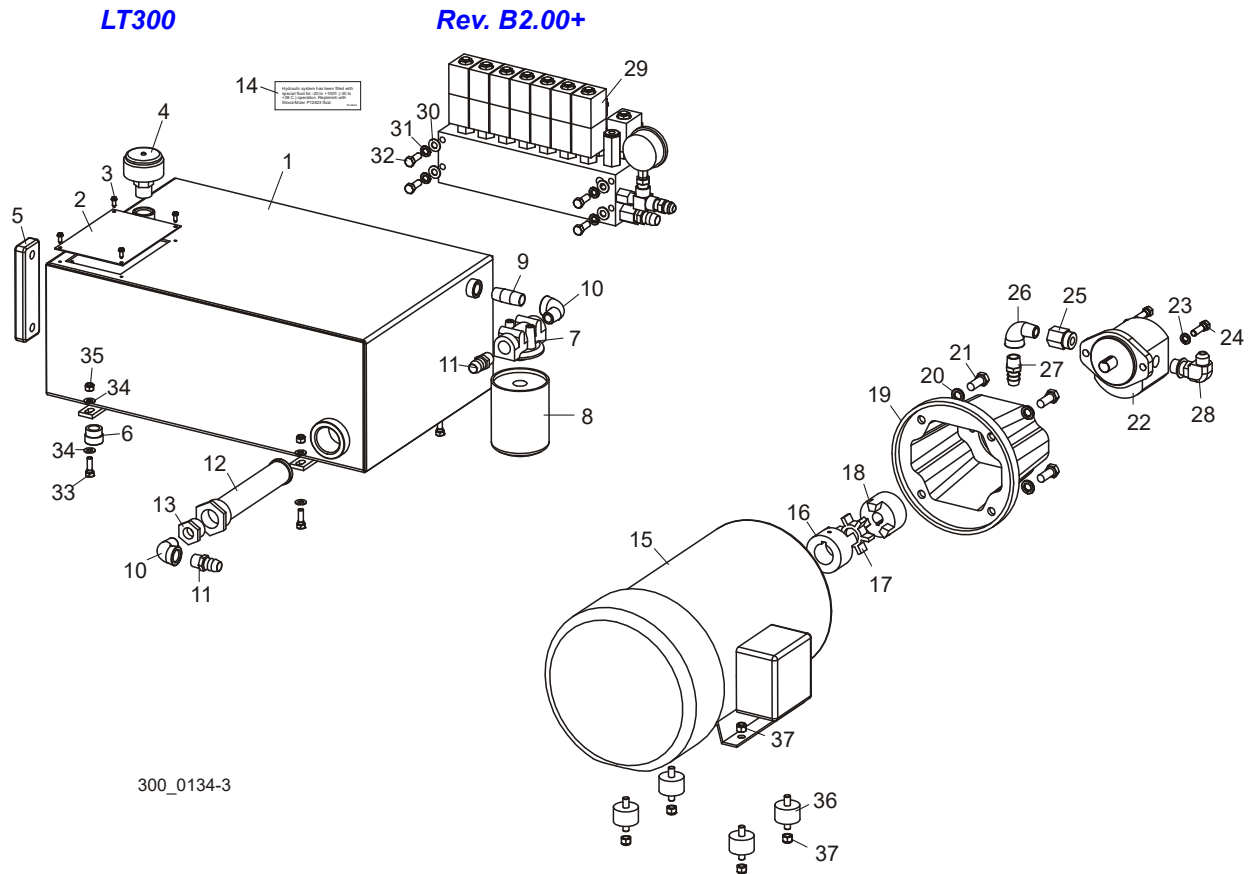

REF	DESCRIPTION (◆ Indicates Parts Available In Assemblies Only)	PART #	QTY.
	<b>TANK ASSEMBLY, HYDRAULIC 10 GALLON</b>	038885	1
1	Tank Weldment, 10 Gallon	038884	1
2	Cover, Hydraulic Tank Access	S20331	1
3	Bolt, #8-32 x 1/2" Slotted Hex Head	F05015-18	4
4	Cap, Hydraulic Breather/Filter	P20212	1
5	Guage, Hydraulic Fluid	P20211	1
6	Fitting, 1/2" NPT Pipe Plug	P26258	2
7	Filter Assembly, Hydraulic Manifold	P22683	1
8	Filter, S28 Hydraulic	P20301	1
9	Fitting, 1/2" NPT x 2" Black Pipe Nipple	016844	1
10	Fitting, 1/2" NPT ST Elbow	P22684	2
11	Fitting, 1/2" NPT Male x 3/4" Hose Barb	035621	2
12	Filter, Hydraulic Tank Suction	P20210	1
13	Fitting, 1/2" x 1" Reducer Bushing	P20239	1
14	Decal, Hydraulic Fluid Replacement	S12825	1

## 8

**Hydraulics***Hydraulic Pump & Tank*

	<b>PUMP ASSEMBLY, 50/60HZ HYDRAULIC</b>	042780	1	
15	Motor, 7 1/2 HP 213TC 50/60Hz 415/480V	042776	1	
16	Coupling, L100 x 1 3/8" Body	042777	1	
17	Coupling, L100 Spider	042779	1	
18	Coupling, L100 x 3/4" Body	042778	1	
19	Adaptor, Hydraulic Pump/50Hz Motor	042781	1	
20	Washer, 1/2" Split Lock	F05011-9	4	
21	Bolt, 1/-13 x 1 1/4" Hex Head Grade 5	F05008-37	4	
22	Pump, 6 GPM Hydraulic 50Hz	042782	1	
23	Washer, 3/8" Split Lock	F05011-4	2	
24	Bolt, 3/8-16 x 1 1/4" Hex Head Grade 5	F05007-123	2	
25	Fitting, 1/2" NPT x #12 SAE Female Adaptor	042785	1	
26	Fitting, 1/2" NPT Galvanized Elbow	P22684	1	
27	Fitting, 1/2" NPT x 3/4" Hose Barb	035621	1	
28	Fitting, #10 SAE x 1/2" JIC 90° Elbow	042784	1	
29	<b>VALVE PARTS</b> ( <a href="#">See Section 8.16</a> )			
30	<b>WASHER, 3/8" SAE FLAT</b>	F05011-3	4	
31	<b>WASHER, 3/8" SPLIT LOCK</b>	F05011-4	4	
32	<b>BOLT, 3/8-16 X 1" HEX HEAD GRADE 5</b>	F05007-87	4	
33	<b>BOLT, 5/16-18 X 1" HEX HEAD</b>	F05006-1	4	
34	<b>WASHER, 5/16" SAE FLAT</b>	F05011-17	8	
35	<b>NUT, 5/16-18 HEX NYLON LOCK</b>	F05010-58	4	
36	<b>MOUNT, RUBBER HYDRAULIC MOTOR</b>	035546	4	
37	<b>NUT, 3/8-16 HEX NYLON LOCK</b>	F05010-10	8	



## 8.14 Hydraulic Pump & Tank

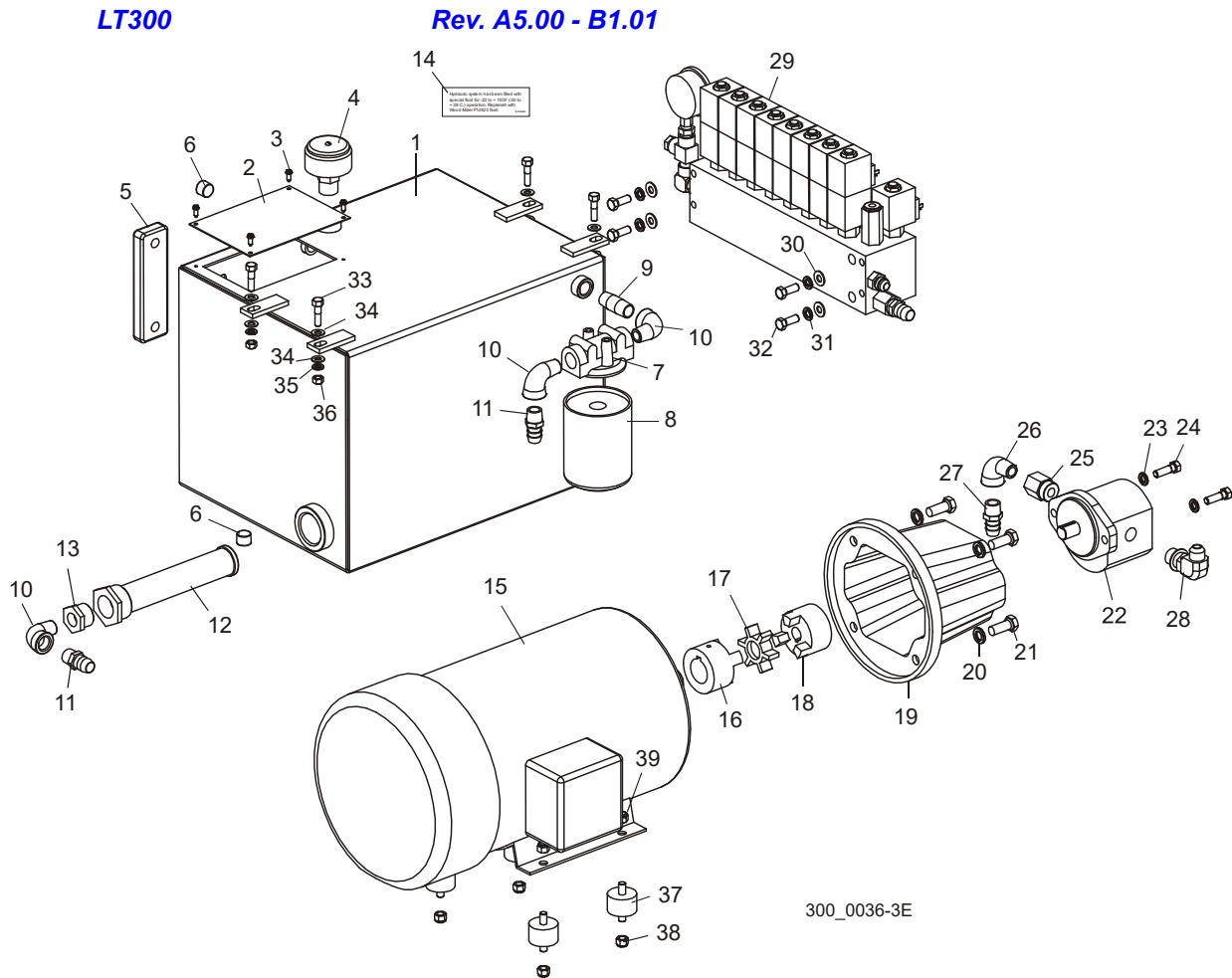

REF	DESCRIPTION (◆ Indicates Parts Available In Assemblies Only)	PART #	QTY.
	<b>TANK ASSEMBLY, HYDRAULIC 10 GALLON</b>	045093	1
1	Tank Weldment, 10 Gallon	045249	1
2	Cover, Hydraulic Tank Access	S20331	1
3	Bolt, #8-32 x 1/2" Slotted Hex Head	F05015-18	4
4	Cap, Hydraulic Breather/Filter	P20212	1
5	Guage, Hydraulic Fluid	P20211	1
6	Fitting, 1/2" NPT Pipe Plug	P26258	2
7	Filter Assembly, Hydraulic Manifold	P22683	1
8	Filter, S28 Hydraulic	P20301	1
9	Fitting, 1/2" NPT x 2" Black Pipe Nipple	016844	1
10	Fitting, 1/2" NPT ST Galvanized Elbow	P22684	3
11	Fitting, 1/2" NPT Male x 3/4" Hose Barb	035621	2
12	Filter, Hydraulic Tank Suction	P20210	1

## 8

## Hydraulics

## Hydraulic Pump &amp; Tank

13	Fitting, 1/2" x 1" Reducer Bushing	P20239	1	
14	Decal, Hydraulic Fluid Replacement	S12825	1	
	<b>PUMP ASSEMBLY, 50/60HZ HYDRAULIC</b>	042780	1	
15	Motor, 7 1/2 HP 213TC 50/60Hz 415/480V	042776	1	
16	Coupling, L100 x 1 3/8" Body	042777	1	
17	Coupling, L100 Spider	042779	1	
18	Coupling, L100 x 3/4" Body	042778	1	
19	Adaptor, Hydraulic Pump/50Hz Motor	042781	1	
20	Washer, 1/2" Split Lock	F05011-9	4	
21	Bolt, 1/13 x 1 1/4" Hex Head Grade 5	F05008-37	4	
22	Pump, 6 GPM Hydraulic 50Hz	042782	1	
23	Washer, 3/8" Split Lock	F05011-4	2	
24	Bolt, 3/8-16 x 1 1/4" Hex Head Grade 5	F05007-123	2	
25	Fitting, 1/2" NPT x #12 SAE Female Adaptor	042785	1	
26	Fitting, 1/2" NPT Galvanized Elbow	P22684	1	
27	Fitting, 1/2" NPT x 3/4" Hose Barb	035621	1	
28	Fitting, #10 SAE x 1/2" JIC 90° Elbow	042784	1	
29	<b>VALVE PARTS</b> ( <a href="#">See Section 8.17</a> )			
30	<b>WASHER, 3/8" SAE FLAT</b>	F05011-3	4	
31	<b>WASHER, 3/8" SPLIT LOCK</b>	F05011-4	4	
32	<b>BOLT, 3/8-16 X 1" HEX HEAD GRADE 5</b>	F05007-87	4	
33	<b>BOLT, 5/16-18 X 1 1/4" HEX HEAD</b>	F05009-62	4	
34	<b>WASHER, 5/16" SAE FLAT</b>	F05011-17	8	
35	<b>WASHER, 5/16" SPLIT LOCK</b>	F05011-13	4	
36	<b>NUT, 5/16-18 HEX</b>	F05010-17	4	
37	<b>MOUNT, RUBBER HYDRAULIC MOTOR</b>	035546	4	
38	<b>NUT, 3/8-16 HEX NYLON LOCK</b>	F05010-10	8	

## 8.15 Hydraulic Pump, Tank & Valve

LT300

Rev. A1.00 - A4.00

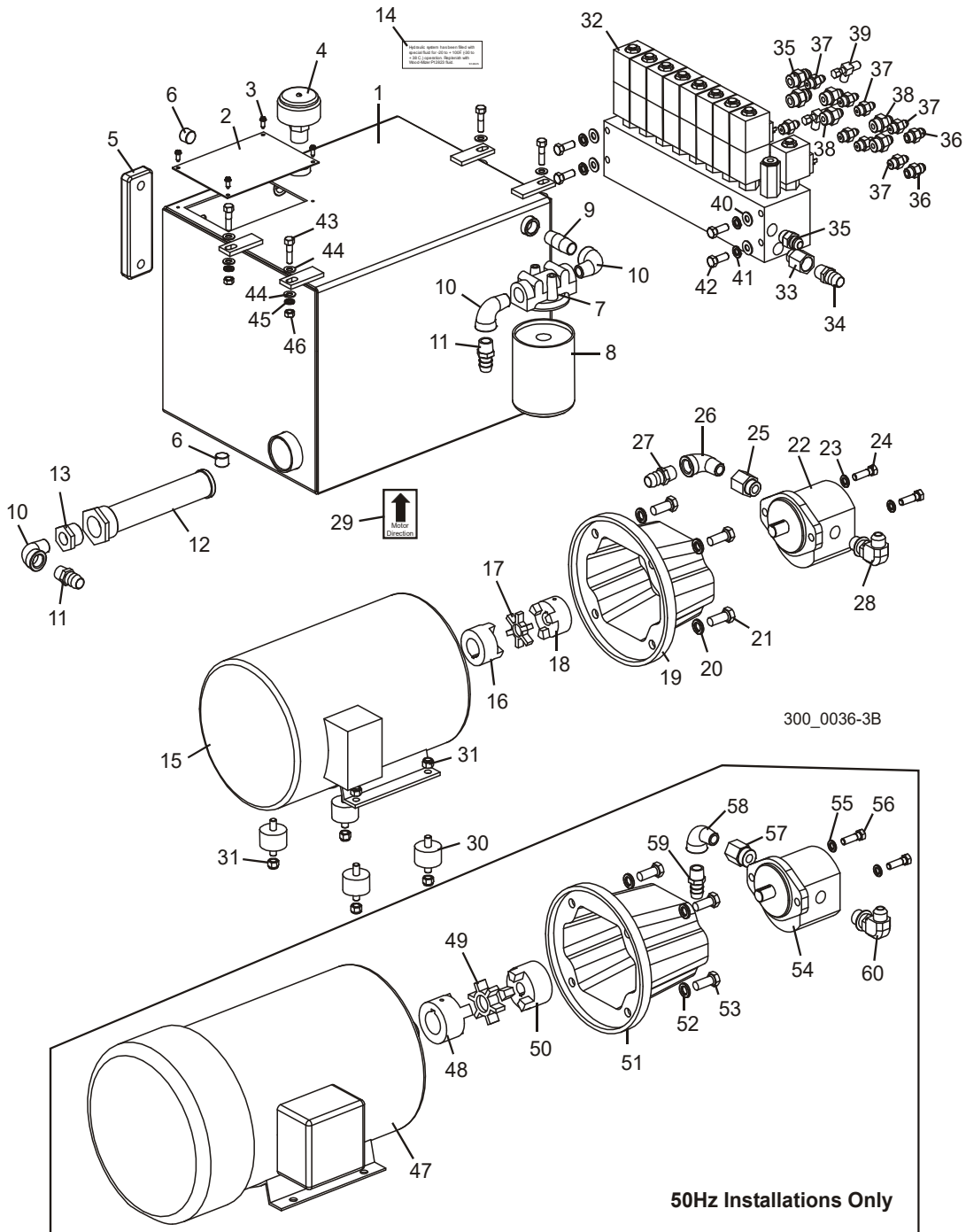

REF	DESCRIPTION (◆ Indicates Parts Available In Assemblies Only)	PART #	QTY.
	<b>TANK ASSEMBLY, HYDRAULIC 10 GALLON</b>	045093	1

## 8

**Hydraulics***Hydraulic Pump, Tank & Valve*

1	Tank Weldment, 10 Gallon	045249	1	
2	Cover, Hydraulic Tank Access	S20331	1	
3	Bolt, #8-32 x 1/2" Slotted Hex Head	F05015-18	4	
4	Cap, Hydraulic Breather/Filter	P20212	1	
5	Guage, Hydraulic Fluid	P20211	1	
6	Fitting, 1/2" NPT Pipe Plug	P26258	2	
7	Filter Assembly, Hydraulic Manifold	P22683	1	
8	Filter, S28 Hydraulic	P20301	1	
9	Fitting, 1/2" NPT x 2" Black Pipe Nipple	016844	1	
10	Fitting, 1/2" NPT ST Galvanized Elbow	P22684	3	
11	Fitting, 1/2" NPT Male x 3/4" Hose Barb	035621	2	
12	Filter, Hydraulic Tank Suction	P20210	1	
13	Fitting, 1/2" x 1" Reducer Bushing	P20239	1	
14	Decal, Hydraulic Fluid Replacement	S12825	1	
	<b>PUMP ASSEMBLY, HYDRAULIC</b>	035623 <sup>1</sup>	1	
15	Motor, 7 1/2 HP 184TC 3450 RPM	045233	1	
16	Coupling, 1 1/8" Body	045236	1	
17	Coupling, L095 Spider	045238	1	
18	Coupling, 3/4" Body	045237	1	
19	Adaptor, Hydraulic Pump/Motor	045234 <sup>2</sup>	1	
20	Washer, 1/2" Split Lock	F05011-9	4	
21	Bolt, 1/-13 x 1 1/4" Hex Head Grade 5	F05008-37	4	
22	Pump, 6 GPM Hydraulic	045235	1	
23	Washer, 3/8" Split Lock	F05011-4	2	
24	Bolt, 3/8-16 x 1 1/4" Hex Head Grade 5	F05007-123	2	
25	Fitting, 1/2" FP x 5/8" O-Ring Straight Adaptor	P26162	1	
26	Fitting, 1/2" NPT Galvanized Elbow	P22684	1	
27	Fitting, 1/2" NPT x 3/4" Hose Barb	035621	1	
28	Fitting, #8 SAE x 1/2" JIC 90° Elbow	016806	1	
29	Decal, Motor Direction	S20097	1	
30	<b>MOUNT, RUBBER HYDRAULIC MOTOR</b>	035546	4	
31	<b>NUT, 3/8-16 HEX NYLON LOCK</b>	F05010-10	8	
	<b>VALVE ASSEMBLY, LT300 HYDRAULIC</b>	035615 <sup>3</sup>	1	◆
32	Valve, 8 Spool Hydraulic ( <a href="#">See Section 8.18</a> for Valve Parts)	042329	1	
33	Fitting, #8 SAE x 1/2" NPT Female Adaptor	035620	1	
34	Fitting, 1/2" NPT x 3/4" Hose Barb	035621	1	
35	Fitting, #8 SAE x #8 JIC	028076	3	
36	Fitting, 3/8" O-Ring x 3/8" JIC	014687	2	
37	Fitting, 1/4" JIC x 3/8" O-Ring	P26284	8	
38	Fitting, #8 SAE x #6 JIC	P12703	4	
39	Fitting, 1/4" Swivel Nut Run Tee	016808	2	
40	<b>WASHER, 3/8" SAE FLAT</b>	F05011-3	4	
41	<b>WASHER, 3/8" SPLIT LOCK</b>	F05011-4	4	

42	<b>BOLT, 3/8-16 X 1" HEX HEAD GRADE 5</b>	F05007-87	4	
43	<b>BOLT, 5/16-18 X 1 1/4" HEX HEAD</b>	F05009-62	4	
44	<b>WASHER, 5/16" SAE FLAT</b>	F05011-17	8	
45	<b>WASHER, 5/16" SPLIT LOCK</b>	F05011-13	4	
46	<b>NUT, 5/16-18 HEX</b>	F05010-17	4	
	<b>PUMP ASSEMBLY, 50HZ HYDRAULIC</b>	042780 <sup>4</sup>	1	
47	Motor, 7 1/2 HP 213TC 50/60Hz 415/480V	042776	1	
48	Coupling, L100 x 1 3/8" Body	042777	1	
49	Coupling, L100 Spider	042779	1	
50	Coupling, L100 x 3/4" Body	042778	1	
51	Adaptor, Hydraulic Pump/50Hz Motor	042781	1	
52	Washer, 1/2" Split Lock	F05011-9	4	
53	Bolt, 1/-13 x 1 1/4" Hex Head Grade 5	F05008-37	4	
54	Pump, 6 GPM Hydraulic 50Hz	042782	1	
55	Washer, 3/8" Split Lock	F05011-4	2	
56	Bolt, 3/8-16 x 1 1/4" Hex Head Grade 5	F05007-123	2	
57	Fitting, 1/2" NPT x #12 SAE Female Adaptor	042785	1	
58	Fitting, 1/2" NPT Galvanized Elbow	P22684	1	
59	Fitting, 1/2" NPT x 3/4" Hose Barb	035621	1	
60	Fitting, #10 SAE x 1/2" JIC 90° Elbow	042784	1	

<sup>1</sup> See Items 47-57 for alternate items for 50Hz installations (Available after Rev. A3.00).

<sup>2</sup> Adaptor changed from Vescor part number 1960 to 6026 to provide additional coupler engagement (Rev. A3.00).

<sup>3</sup> Pressure gauge and fittings added Rev. A5.00. 8-Port valve assembly 035615 and valve 042329 obsolete. Valve assembly replaced with 7-port valve Rev. A9.00 ([See Section 8.17](#)). Use kit 036758 to replace valve on LT300 without optional loader or log deck. Use kit 036824 to replace valve on LT300 with optional log loader. Use kit 036825 to replace valve with optional log deck.

<sup>4</sup> Assembly replaces assembly 035623 for 50Hz installations.

## 8.16 Hydraulic Valve

LT300

Retrofit

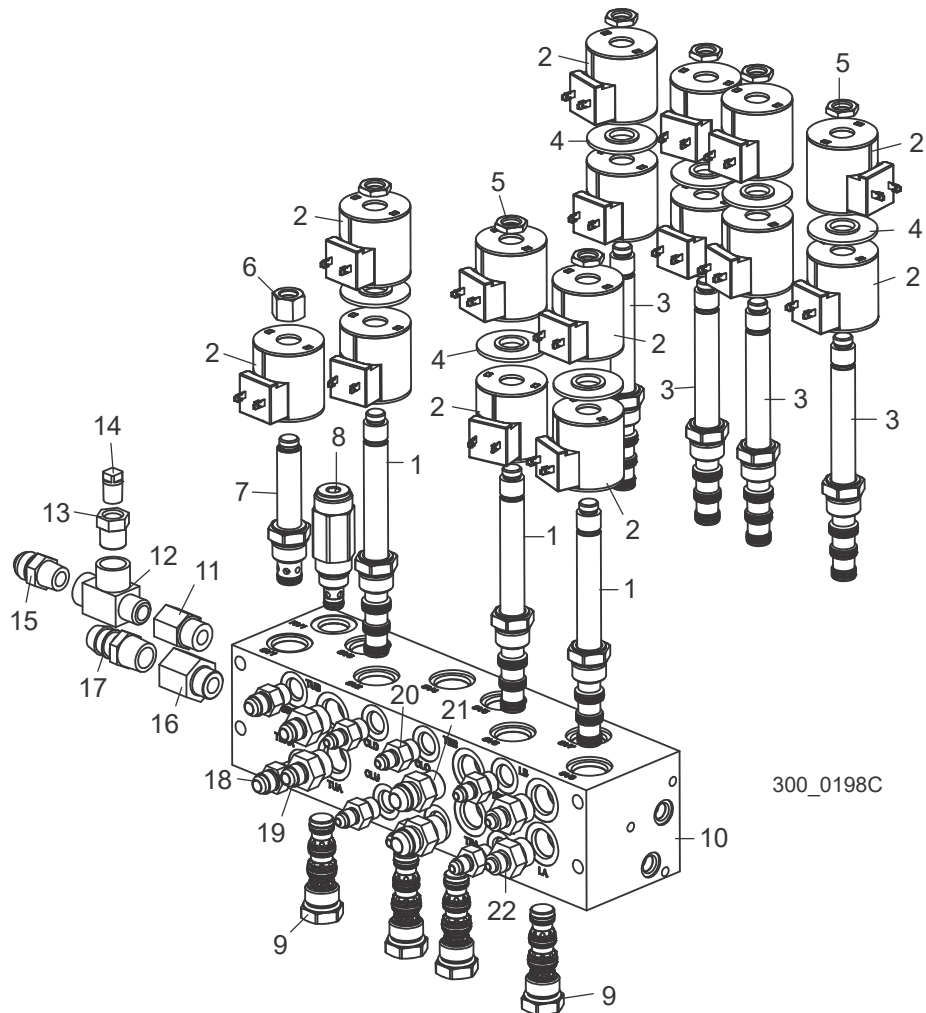

REF	DESCRIPTION (◆ Indicates Parts Available In Assemblies Only)	PART #	QTY.
	<b>VALVE ASSEMBLY, LT300 HYDRAULIC</b>	036758 <sup>1</sup>	1
	Valve, 7-Spool Expandable Hydraulic	025689	1
1	Valve, SV10-47C Hydraulic (Loader, Turner, Side Supports)	025830	3
	Kit, Seal SK10-4N-MMM One Per Spool	061104	1
2	Coil, 24VDC Hydraulic Valve	025835	15
3	Valve, SV10-47D Hydraulic (Clamp, Toe Boards)	025829	4
	Kit, Seal SK10-4N-MMM One Per Spool	061104	1
4	Spacer, SV10-47 Valve Coil	025838	7
5	Nut, SV10-47 Valve Coil	025837	7
6	Nut, SV10-21 Valve Coil	025836	1
7	Valve, SV10-21 Hydraulic (By-Pass)	025831	1

	Kit, Seal SK10-2N-T One Per Spool	061105	1	
<b>8</b>	Valve, Relief (SK08-2N-T)	025833	1	
	Kit, Seal SK08-2N-T Relief Valve	061107	1	
<b>9</b>	Valve, Dual PO Check (DC10-40)	025832	4	
	Kit, Seal SK10-4N-MMM One Per Spool	061104	1	
<b>10</b>	Manifold, M&W 07-0667 Black Anodized	061284	1	
<b>11</b>	Fitting, #8 SAE x 3/8" NPT Female Adapter	P12706	1	
<b>12</b>	Fitting, 3/8" NPT Male Run Tee	016822	1	
<b>13</b>	Fitting, 3/8" NPT-1/4 NPT Reducer	015490	1	
<b>14</b>	Plug, 1/4" NPT Pipe	P05498 <sup>2</sup>	1	
<b>15</b>	Fitting, 3/8" NPT x #8 JIC	036822	1	
<b>16</b>	Fitting, #8SAE x 1/2" NPT Female Adapter	035620	1	
<b>17</b>	Fitting, 1/2" NPT x 3/4" Hose Barb	035621	1	
<b>18</b>	Fitting, 3/8" O-Ring x 3/8" JIC	014687	2	
<b>19</b>	Fitting, #8 SAE x #6 JIC	P12703	2	
<b>20</b>	Fitting, 1/4" JIC x 3/8" O-Ring	P26284	6	
<b>21</b>	Fitting, #8 SAE x #8 JIC	028076	2	
<b>22</b>	Fitting, #8 SAE x 1/4" JIC	036759	2	

<sup>1</sup> Torque cartridge spools to 24-26 ft-lbs. Torque coil nuts to 7-10 ft-lbs.

<sup>2</sup> Replaces 5000 PSI Hydraulic Pressure Gauge P10052 (Rev. B5.02).

## 8.17 Hydraulic Valve

LT300

Rev. A9.00 - B4.01

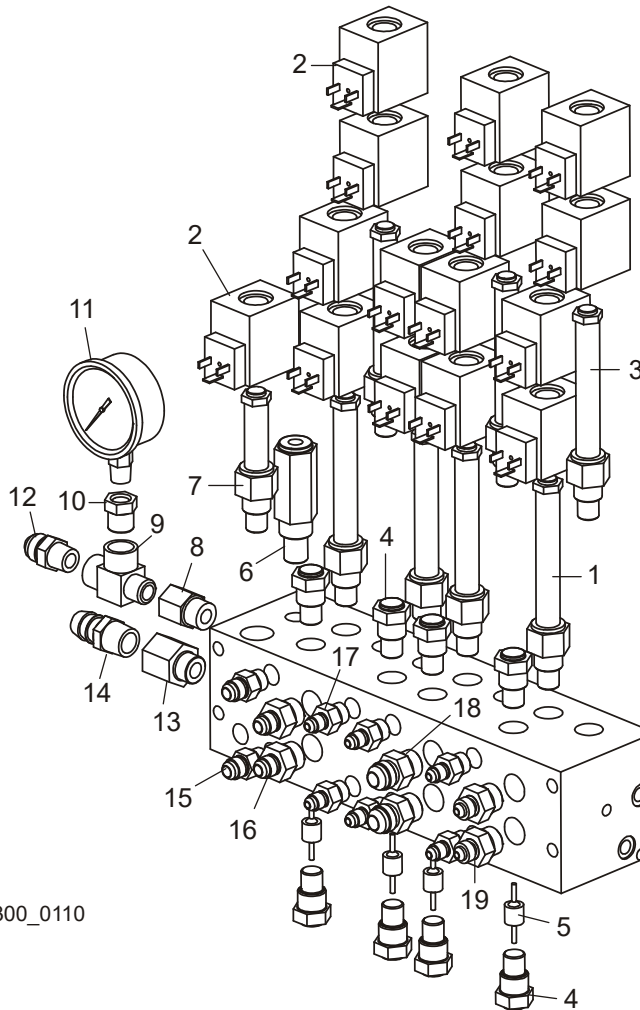

300\_0110

REF	DESCRIPTION (◆ Indicates Parts Available In Assemblies Only)	PART #	QTY.	
	<b>VALVE ASSEMBLY, LT300 HYDRAULIC</b>	036758 <sup>1</sup>	1	
	Valve, 7-Spool Expandable Hydraulic	036731 <sup>2</sup>	1	◆
1	4-Way Sterling #GS04-54-0-0-NC (Clamp & Toe Boards #1 & #2)	045820	4	
2	Coil, 24V Sterling #CAP-024D	051558	15	
3	Valve, 4-Way Sterling #GS04-52-0-0-NC (Turner, Side Supports & Toe Board #3)	051556	3	
4	Valve, Check Sterling #D02B2-2.1N	051559	8	
5	Piston, Pilot Sterling #PP02DP	051560	4	
6	Valve, Relief Sterling #208-1-B-0-A-C-200	051554	1	
7	Valve, 2-Way NO Sterling #GS04-26	051555	1	
	Seal Kit, 7-Section Hydraulic Valve #PPC302000	006940	1	



8	Fitting, #8 SAE x 3/8" NPT Female Adapter	P12706	1	
9	Fitting, 3/8" NPT Male Run Tee	016822	1	
10	Fitting, 3/8" NPT-1/4 NPT Reducer	015490	1	
11	Gauge, 5000 PSI Hydraulic	P10052	1	
12	Fitting, 3/8" NPT x #8 JIC	036822	1	
13	Fitting, #8SAE x 1/2" NPT Female Adapter	035620	1	
14	Fitting, 1/2" NPT x 3/4" Hose Barb	035621	1	
15	Fitting, 3/8" O-Ring x 3/8" JIC	014687	2	
16	Fitting, #8 SAE x #6 JIC	P12703	2	
17	Fitting, 1/4" JIC x 3/8" O-Ring	P26284	6	
18	Fitting, #8 SAE x #8 JIC	028076	2	
19	Fitting, #8 SAE x 1/4" JIC	036759	2	

<sup>1</sup> Valve Assembly 036758 revised 8/10. New assembly includes new valve that requires different internal service parts ([See Section 8.16](#)).

<sup>2</sup> Valve 036731 no longer available. Use component parts to service or replace with Valve 025689 ([See Section 8.16](#)).

## 8.18 Hydraulic Valve

LT300

Rev. A7.00 - A8.00

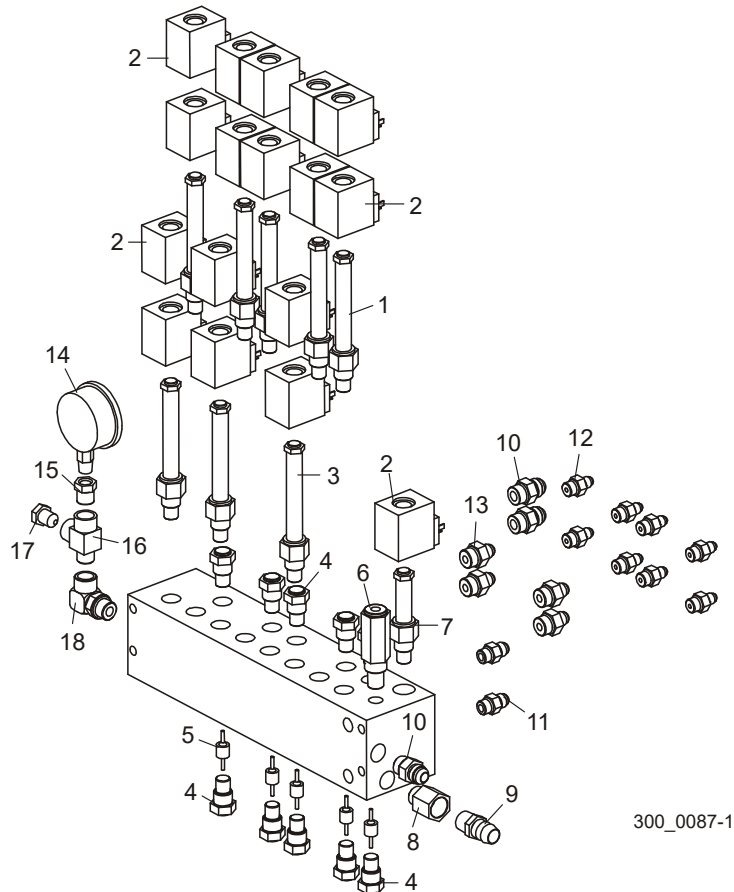

REF	DESCRIPTION (◆ Indicates Parts Available In Assemblies Only)	PART #	QTY.	
	<b>VALVE ASSEMBLY, LT300 HYDRAULIC</b>	035615 <sup>1</sup>	1	◆
	Valve, 8 Spool Hydraulic	042329 <sup>1</sup>	1	◆
1	Valve, Hi-Flow Floating Center Sterling #GS04-53 (Clamp & Toe Boards)	045820	5	
2	Coil, 24V Sterling #CAP-024D	051558	17	
3	Valve, 4-Way Sterling #GS04-51 (Turner, Side Supports & Loading Arm)	051556	3	
4	Valve, Check Sterling #D02B2-2.1N	051559	10	
5	Piston, Pilot Sterling #PP02DP	051560	5	
6	Valve, Relief Sterling #208-1-B-0-A-C-200	051554	1	
7	Valve, 2-Way NO Sterling #GS04-26	051555	1	
8	Fitting, #8 SAE x 1/2" NPT Female Adaptor	035620	1	
9	Fitting, 1/2" NPT x 3/4" Hose Barb	035621	1	
10	Fitting, #8 SAE x #8 JIC	028076	3	
11	Fitting, 3/8" O-Ring x 3/8" JIC	014687	2	
12	Fitting, 1/4" JIC x 3/8" O-Ring	P26284	8	

<b>13</b>	Fitting, #8 SAE x #6 JIC	P12703	4	
<b>14</b>	Gauge, 5000 PSI Hydraulic	P10052	1	
<b>15</b>	Fitting, 3/8" NPT-1/4 NPT Reducer	015490	1	
<b>16</b>	Fitting, 3/8" NPT Male Run Tee	016822	1	
<b>17</b>	Plug, 3/8" NPT Pipe Hex	P10367	1	
<b>18</b>	Fitting, #8 SAE 90° Elbow 3/8	036164	1	

<sup>1</sup> 8-Port valve assembly 035615 and valve 042329 obsolete. Valve assembly replaced with 7-port valve Rev. A9.00 ([See Section 8.17](#)). Use kit 036758 to replace valve on LT300. Add valve kit 036824 if LT300 equipped with optional log loader. Add valve kit 036825 if LT300 equipped with optional log deck.

## 8.19 Hydraulic Valve

LT300

Rev. A1.00 - A6.01

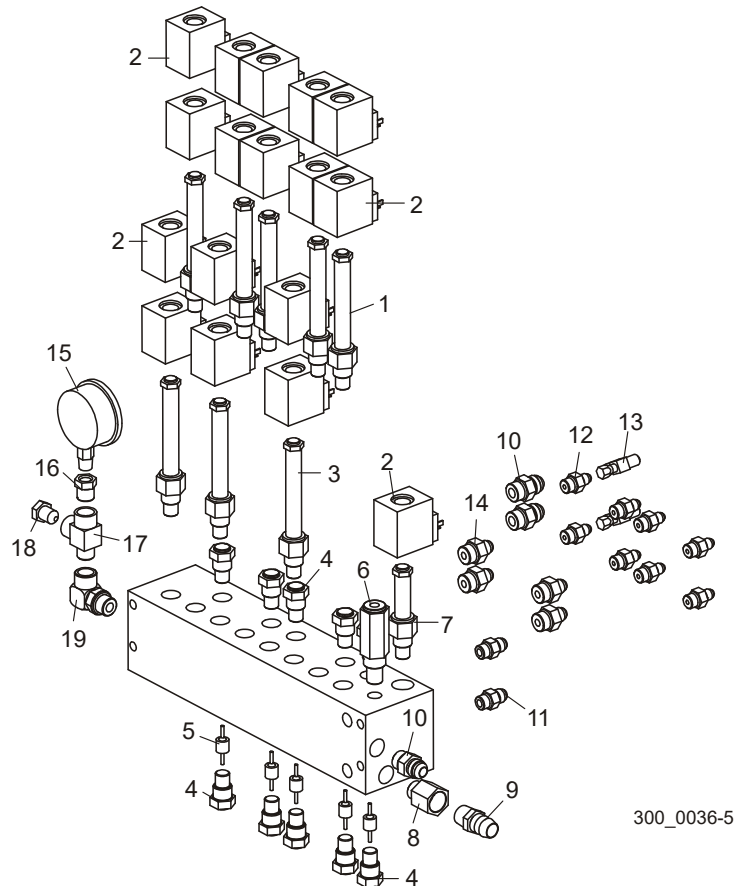

300\_0036-5

REF	DESCRIPTION (◆ Indicates Parts Available In Assemblies Only)	PART #	QTY.	
	<b>VALVE ASSEMBLY, LT300 HYDRAULIC</b>	035615 <sup>1</sup>	1	◆
	Valve, 8 Spool Hydraulic	042329 <sup>1</sup>	1	◆
1	Valve, Hi-Flow Floating Center Sterling #GS04-53 (Clamp & Toe Boards)	045820	5	
2	Coil, 24V Sterling #CAP-024D	051558	17	
3	Valve, 4-Way Sterling #GS04-51 (Turner, Side Supports & Loading Arm)	051556	3	
4	Valve, Check Sterling #D02B2-2.1N	051559	10	
5	Piston, Pilot Sterling #PP02DP	051560	5	
6	Valve, Relief Sterling #208-1-B-0-A-C-200	051554	1	
7	Valve, 2-Way NO Sterling #GS04-26	051555	1	
8	Fitting, #8 SAE x 1/2" NPT Female Adaptor	035620	1	
9	Fitting, 1/2" NPT x 3/4" Hose Barb	035621	1	
10	Fitting, #8 SAE x #8 JIC	028076	3	
11	Fitting, 3/8" O-Ring x 3/8" JIC	014687	2	
12	Fitting, 1/4" JIC x 3/8" O-Ring	P26284	8	

13	Fitting, 1/4" Swivel Nut Run Tee	016808 <sup>2</sup>	2	
14	Fitting, #8 SAE x #6 JIC	P12703	4	
15	Gauge, 5000 PSI Hydraulic	P10052 <sup>3</sup>	1	
16	Fitting, 3/8" NPT-1/4 NPT Reducer	015490	1	
17	Fitting, 3/8" NPT Male Run Tee	016822	1	
18	Plug, 3/8" NPT Pipe Hex	P10367	1	
19	Fitting, #8 SAE 90° Elbow 3/8	036164	1	

<sup>1</sup> 8-Port valve assembly 035615 and valve 042329 obsolete. Valve assembly replaced with 7-port valve Rev. A9.00 ([See Section 8.17](#)). Use kit 036758 to replace valve on LT300 without optional loader or log deck. Use kit 036824 to replace valve on LT300 with optional log loader. Use kit 036825 to replace valve with optional log deck.

<sup>2</sup> 'T' Fittings removed Rev. A7.00.

<sup>3</sup> Pressure gauge and fittings added Rev. A5.00.



**Hydraulics**  
*Hydraulic Valve*

---

## 8.20 Power Taper Set Roller (Optional)

LT300/WM3000/WM3500

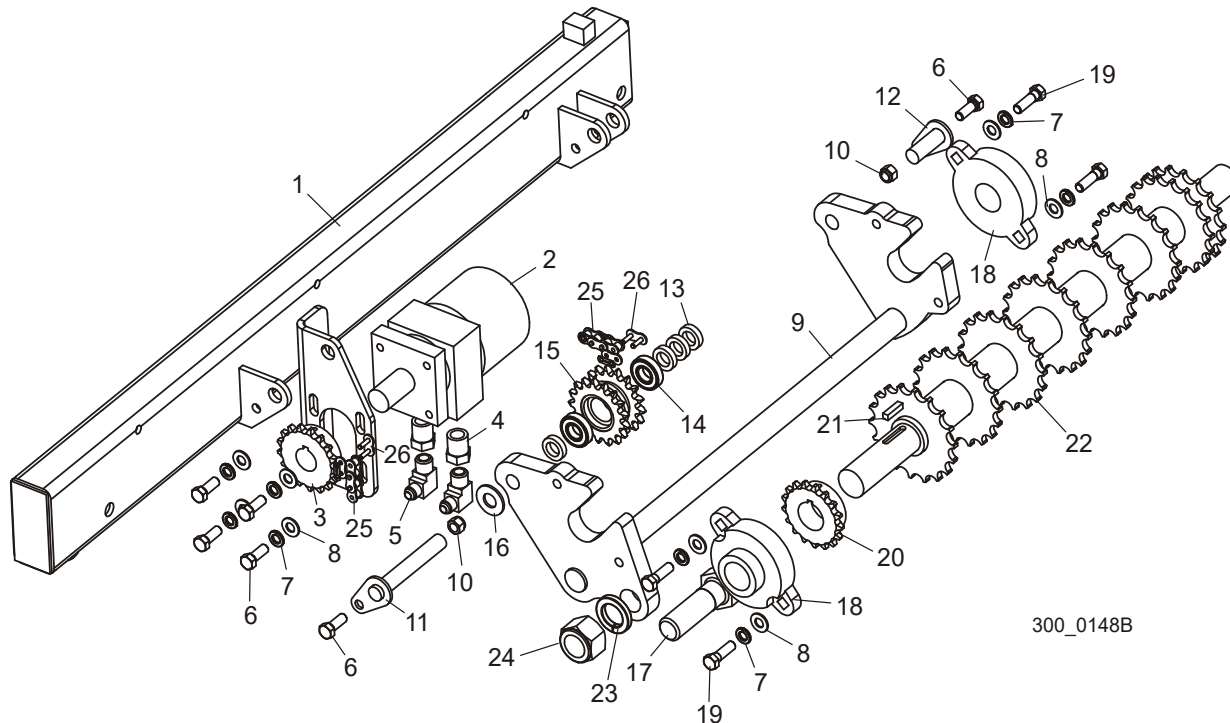

REF	DESCRIPTION (◆ Indicates Parts Available In Assemblies Only)	PART #	QTY.
	<b>TUBE ASSEMBLY, REAR POWER TAPER SET ROLLER</b>	003873 <sup>1</sup>	1
	<b>TUBE ASSEMBLY, FRONT POWER TAPER SET ROLLER</b>	006676 <sup>1</sup>	1
1	Tube Weldment, Rear Power Taper Set Roller	003875	1
	Tube Weldment, Front Power Taper Set Roller	006678	1
2	Motor, Hydraulic #MG06-13-13AAAB	P21506	1
	Seal Kit, Hydraulic Motor	061136	1
3	Sprocket, 40B17 x 1"	003883	1
4	Fitting, 1/2" NPT x 3/8" NPT Hex Reducer	028073	2
5	Fitting, 3/8" NPT-3/8" JIC 90 Elbow	016820	2
6	Bolt, 3/8-16 x 1" Hex Head Grade 5	F05007-87	7
7	Washer, 3/8" Split Lock	F05011-4	7
8	Washer, 3/8" Flat SAE	F05011-3	8
9	Roller Weldment, Rear Toe Board	003879	1
	Roller Weldment, Front Toe Board	006679	1
10	Nut, 3/8-16 Hex Nylon Lock	F05010-10	2
11	Pin Weldment, 5/8" x 4 1/16"	003886	1
12	Pin Weldment, 5/8" x 1 3/4"	003887	1

## 8

**Hydraulics***Power Taper Set Roller (Optional)*

13	Spacer, .63" x 1.00" x .25"	017719	4	
14	Bearing, R-10	P04156	2	
15	Sprocket Wedment, Dual 17/17T	W12474	1	
16	Washer, 5/8" SAE Flat	F05011-5	1	
17	Washer, 3/8" ID x 1 1/4" OD	S02779	1	
18	Bearing, 1 1/4" Flange, IPTCI	003896	1	
19	Bolt, 3/8-16 x 1 1/4" Hex Head Grade 5	F05007-123	4	
20	Sprocket, 40B17 x 1 1/4"	003884	1	
21	Key, 1/4" x 1"	S21486	1	
22	Roller, Powered Toeboard	003881	1	
23	Washer, 1" Split Lock	F05011-53	1	
24	Nut, 1-8 Self-Locking Hex	F05010-109	1	
25	Chain, #40 x 32 Pitch	003895	2	
26	Link, #40 Master	P04200	2	

<sup>1</sup> Front (4/09) and rear (12/07) power taper set roller option available (Rev. A9.00 and later only).



### 8.21 Valve Assembly, Power Taper Set Roller (Optional)

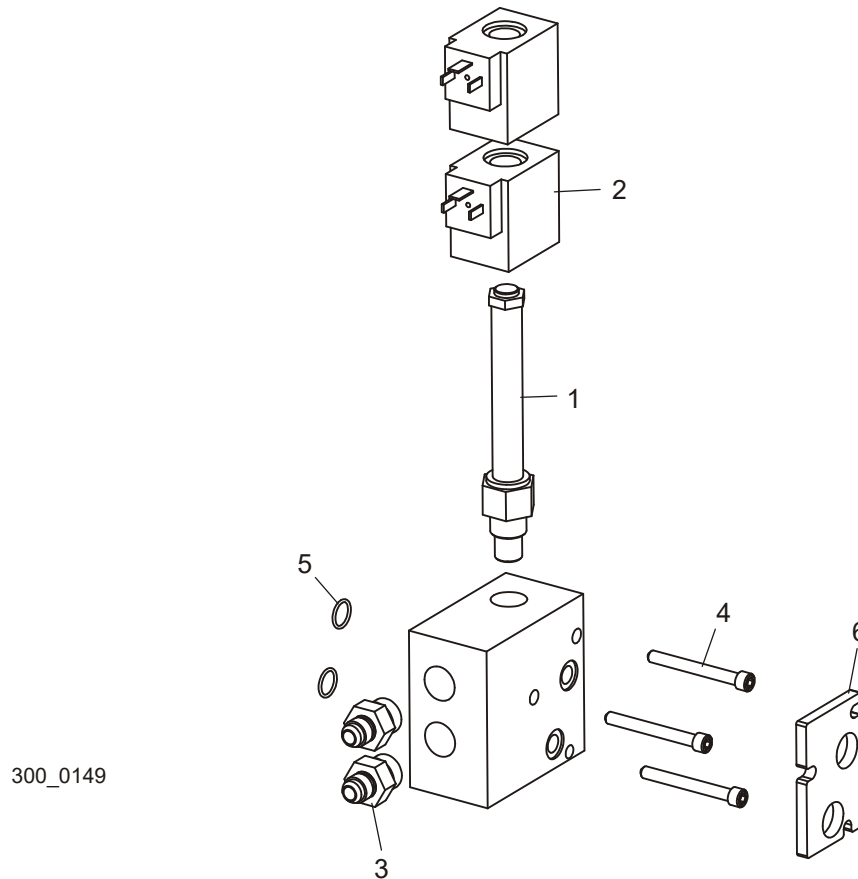

REF	DESCRIPTION (◆ Indicates Parts Available In Assemblies Only)	PART #	QTY.
	<b>VALVE ASSEMBLY, 300LA ADD-ON</b>	036824 <sup>1</sup>	1
	Valve, 24V Hydraulic Add-On 4-Way Closed	025827 <sup>2</sup>	1
<b>1</b>	Valve, Hi-Flow Floating Center Hydraulic	045820 <sup>3</sup>	1
	Valve, 4-Way Hydraulic	051556 <sup>3</sup>	1
<b>2</b>	Coil, 24V Hydraulic #CAP-024D	051558	2
<b>3</b>	Fitting, 8 SAE-3/8" JIC	P12703	2
<b>4</b>	Screw, 1/4-20 x 2 1/4" Socket Head Cap	F05005-170	3
<b>5</b>	O-Ring, .070" Dia. x 5/8" OD #2-014 Buna-N	036806	2
<b>6</b>	<b>PLATE, ADD-ON VALVE SPACER (W/ADDITIONAL VALVES ONLY)</b>	003929	1
	<b>SCREW, 1/4-20 X 6 1/2" SOCKET HEAD CAP (W/ADDITIONAL VALVES ONLY)</b>	F05005-182	3

<sup>1</sup> Valve for power taper set roller option available 12/07 for LT300 Rev. A9.00 and later only.

<sup>2</sup> Replaces 036724 valve used from 12/10 to 5/14. 036724 replaced 036733 check valve used prior to PTSR Rev. A.02 (12/10).

<sup>3</sup> Use 045820 to service Valve 036734 supplied after 12/10 (PTSR Rev. A.02+). Use 051556 to service 036733 valve supplied prior to 12/10.

## 8.22 Hydraulic Hoses

LT300

Rev. A7.00+

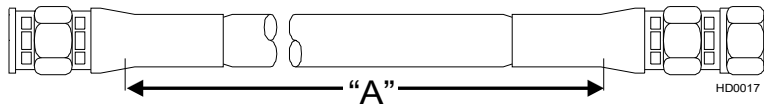

COLOR	LENGTH "A" LT300	LENGTH "A" LT300-BX6	LENGTH "A" LT300-BX10	DESCRIPTION	Part No. LT300	Part No. LT300-BX6	Part No. LT300-BX10
				GROMMET, 2 1/2" DIAMETER RUBBER		085614	
				GROMMET, 4 3/8" X 10" OVAL	N/A	085759	085759
<b>1/4" Hydraulic Hoses</b>							
Yellow	158"	230"	278"	1/4" TOE BOARD #1 TOP	036566		
Grey	158"	230"	278"	1/4" TOE BOARD #1 BASE	036566		
Purple	247"	319"	367"	1/4" TOE BOARD #2 TOP	036067		
Black	243"	315"	363"	1/4" TOE BOARD #2 BASE	036567		
Red	283"	355"	411"	1/4" TOE BOARD #3 TOP	036568		
Blue	281"	353"	409"	1/4" TOE BOARD #3 BASE	036569		
Yellow	256"	328"	376"	1/4" CLAMP UP/DOWN BASE	036560		
Green	268"	340"	388"	1/4" CLAMP UP/DOWN TOP	036066		
<b>3/8" Hydraulic Hoses</b>							
Pink	224"	296"	344"	3/8" LOG TURNER IN/OUT BASE	036561		
Plain	224"	296"	344"	3/8" LOG TURNER IN/OUT TOP	036561		
White	220"	292"	340"	3/8" CLAMP IN/OUT TOP	036563		
Orange	211"	283"	331"	3/8" CLAMP IN/OUT BASE	036069		
Plain	23"			3/8" SIDE SUPPORT BRANCH 'T' (TURNER)		036073	
Plain			23"	3/8" BX SIDE SUPPORT BRANCH 'T' (TURNER)			036073
Plain	29"			3/8" SIDE SUPPORT BRANCH 'T' (FRONT TOP)		036074	
Plain			29"	3/8" BX SIDE SUPPT BRANCH 'T' (FRONT TOP)			036074
Plain	39"			3/8" SIDE SUPPORT BRANCH 'T' (REAR TOP)		036075	
Plain	39"			3/8" SIDE SUPPORT BRANCH 'T' (FRONT BASE)		036075	
Plain			39"	3/8" BX SIDE SUPPT BRANCH 'T' (REAR TOP)			036075
Plain			39"	3/8" BX SIDE SUPPT BRANCH 'T' (FRONT BASE)			036075
Plain	43"			3/8" SIDE SUPPORT BRANCH 'T' (REAR BASE)		036077	
Plain			43"	3/8" BX SIDE SUPPORT BRANCH			036077
Pink			43"	3/8" BX MAIN VALVE TO FLOW DIVIDER #3			036077
Plain			48"	3/8" BX MAIN VALVE TO FLOW DIVIDER #3			
Pink			26"	3/8" BX FLOW DIVIDER #4 TO DIVERter #2			
Plain			26"	3/8" BX FLOW DIVIDER #4 TO DIVERter #2			
Pink			6"	3/8" BX FLOW DIVIDER #2 TO T FITTING			
Plain			6"	3/8" BX FLOW DIVIDER #2 TO T FITTING			

Pink			18"	3/8" BX DIVERTER #3 TO T FITTING			
Plain			18"	3/8" BX DIVERTER #3 TO T FITTING			
Pink			160"	3/8" BX TURNER UP/DOWN BASE			
Plain			160"	3/8" BX TURNER UP/DOWN TOP			
<b>3/8" Hydraulic Hoses (Loading Arm Option) <sup>2</sup></b>							
Blue	230"		302"	3/8" LOADING ARM TOP	036565		
Red	230"		302"	3/8" LOADING ARM BOTTOM	036565		
Green			88"	3/8" LOADING ARM BRANCH TOP		036080	
Green			56"	3/8" LOADING ARM BRANCH TOP		036081	
Yellow			86"	3/8" LOADING ARM BRANCH BASE		036082	
Yellow			54"	3/8" LOADING ARM BRANCH BASE		036083	
<b>1/2" Hydraulic Hoses</b>							
Purple	188"	260"	320"	1/2" TURNER MOTOR	036564 <sup>3</sup>		
Black	188"	260"	120"	1/2" TURNER MOTOR (BX TURNER ON BX10)	036564 <sup>3</sup>		
Plain			24"	1/2" MOTOR TO VALVE		036079	
Purple/Black			236"	1/2" TURNER MOTOR TO BX TURNER MOTOR			
<b>3/4" Low Pressure Hydraulic Hoses</b>							
Plain	35"	44"	35"	3/4" LOW PRESSURE VALVE TO FILTER			
Plain	35"	44"	35"	3/4" LOW PRESSURE TANK TO PUMP			

<sup>1</sup> Rev. A7.00: Toe Board hose lengths shortened to accommodate routing outside of frame. Toe Board #1 and hoses removed. Log Loader hoses removed and structured with option.

<sup>2</sup> Loading Arm became optional after Rev. A3.00. Hoses supplied with option.

<sup>3</sup> Turner motor hoses 036564 lengthened 6" to accommodate 7-section valve (Rev. A9.00).

## 8.23 Hydraulic Hoses

LT300

Rev. A5.00 - A6.01

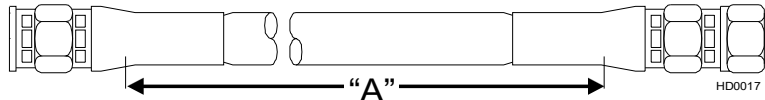

COLOR	LENGTH "A" <sup>1</sup>	DESCRIPTION	Part No.
		GROMMET, 2 1/2" DIAMETER RUBBER	085614
<b>1/4" Hydraulic Hoses</b>			
Orange	136"	1/4" TOE BOARD #1 TOP	036553
White	129"	1/4" TOE BOARD #1 BASE	036554
Yellow	172"	1/4" TOE BOARD #2 TOP	036555
Gray	172"	1/4" TOE BOARD #2 BASE	036555
Purple	249"	1/4" TOE BOARD #3 TOP	036556
Black	249"	1/4" TOE BOARD #3 BASE	036556
Red	293"	1/4" TOE BOARD #4 TOP	036557
Blue	289"	1/4" TOE BOARD #4 BASE	036558
Yellow	256"	1/4" CLAMP UP/DOWN BASE	036560
Green	269"	1/4" CLAMP UP/DOWN TOP	036066
<b>3/8" Hydraulic Hoses</b>			
Blue	230"	3/8" LOADING ARM TOP	036565
Red	230"	3/8" LOADING ARM BOTTOM	036565
Pink	224"	3/8" LOG TURNER IN/OUT BASE	036561
Plain	224"	3/8" LOG TURNER IN/OUT TOP	036561
White	220"	3/8" CLAMP IN/OUT TOP	036563
Dark Orange	210"	3/8" CLAMP IN/OUT BASE	036069
Green	88"	3/8" LOADING ARM BRANCH TOP	036080
Green	56"	3/8" LOADING ARM BRANCH TOP	036081
Yellow	86"	3/8" LOADING ARM BRANCH BASE	036082
Yellow	54"	3/8" LOADING ARM BRANCH BASE	036083
Plain	23"	3/8" SIDE SUPPORT BRANCH 'T' (TURNER)	036073
Plain	29"	3/8" SIDE SUPPORT BRANCH 'T' (FRONT TOP)	036074
Plain	39"	3/8" SIDE SUPPORT BRANCH 'T' (REAR TOP)	036075
Plain	39"	3/8" SIDE SUPPORT BRANCH 'T' (FRONT BASE)	036075
Plain	43"	3/8" SIDE SUPPORT BRANCH 'T' (REAR BASE)	036077
<b>1/2" Hydraulic Hoses</b>			
Purple	188"	1/2" TURNER MOTOR	036564 <sup>2</sup>
Black	188"	1/2" TURNER MOTOR	036564 <sup>2</sup>
Plain	24"	1/2" MOTOR TO VALVE	036079
<b>3/4" Low Pressure Hydraulic Hoses</b>			
Plain	44"	3/4" LOW PRESSURE VALVE TO FILTER	
Plain	44"	3/4" LOW PRESSURE TANK TO PUMP	

<sup>1</sup> Hose lengths increased 20" to accommodate 26' LT300 bed (Rev. A5.00).

<sup>2</sup> Turner motor hoses 036564 lengthened 6" to accommodate 7-section valve (Rev. A9.00).

## 8.24 Hydraulic Hoses

LT300

Rev. A1.00 - A4.00

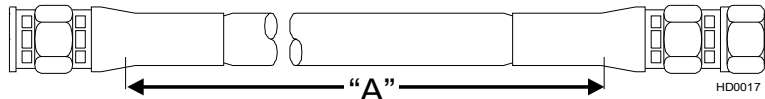

COLOR	LENGTH "A"	DESCRIPTION	Part No.
		GROMMET, 2 1/2" DIAMETER RUBBER	085614
<b>1/4" Hydraulic Hoses <sup>1</sup></b>			
	116"	1/4" TOE BOARD #1 TOP	036061
	109"	1/4" TOE BOARD #1 BASE	036062
Yellow	152"	1/4" TOE BOARD #2 TOP	036063
Gray	152"	1/4" TOE BOARD #2 BASE	036063
Purple	229"	1/4" TOE BOARD #3 TOP	036064
Black	229"	1/4" TOE BOARD #3 BASE	036064
	273"	1/4" TOE BOARD #4 TOP	036065
	269"	1/4" TOE BOARD #4 BASE	036066
Yellow	235"	1/4" CLAMP UP/DOWN BASE	036068
Green	247"	1/4" CLAMP UP/DOWN TOP	036067
<b>3/8" Hydraulic Hoses <sup>1</sup></b>			
Blue	210"	3/8" LOADING ARM TOP	036069
Red	210"	3/8" LOADING ARM BOTTOM	036069
Pink	204"	3/8" LOG TURNER IN/OUT BASE	036070
Plain	204"	3/8" LOG TURNER IN/OUT TOP	036070
White	200"	3/8" CLAMP IN/OUT TOP	036072
Orange	191"	3/8" CLAMP IN/OUT BASE	036071
Green	88"	3/8" LOADING ARM BRANCH TOP	036080
Green	56"	3/8" LOADING ARM BRANCH TOP	036081
Yellow	86"	3/8" LOADING ARM BRANCH BASE	036082
Yellow	54"	3/8" LOADING ARM BRANCH BASE	036083
	23"	3/8" SIDE SUPPORT BRANCH 'T' (TURNER)	038073
	29"	3/8" SIDE SUPPORT BRANCH 'T' (FRONT TOP)	036074
	39"	3/8" SIDE SUPPORT BRANCH 'T' (REAR TOP)	036075
	37"	3/8" SIDE SUPPORT BRANCH 'T' (FRONT BASE)	036076
	43"	3/8" SIDE SUPPORT BRANCH 'T' (REAR BASE)	036077
<b>1/2" Hydraulic Hoses <sup>1</sup></b>			
Purple	162"	1/2" TURNER MOTOR	036078
Black	162"	1/2" TURNER MOTOR	036078
	24"	1/2" MOTOR TO VALVE	036079
<b>3/4" Low Pressure Hydraulic Hoses</b>			
	44"	3/4" LOW PRESSURE VALVE TO FILTER	
	44"	3/4" LOW PRESSURE TANK TO PUMP	

<sup>1</sup> Double-braided hoses replace all hydraulic hoses previously supplied prior to Rev. A3.00.

## SECTION 9 MISCELLANEOUS

### 9.1 Lube System

LT300Rev. A9.05+

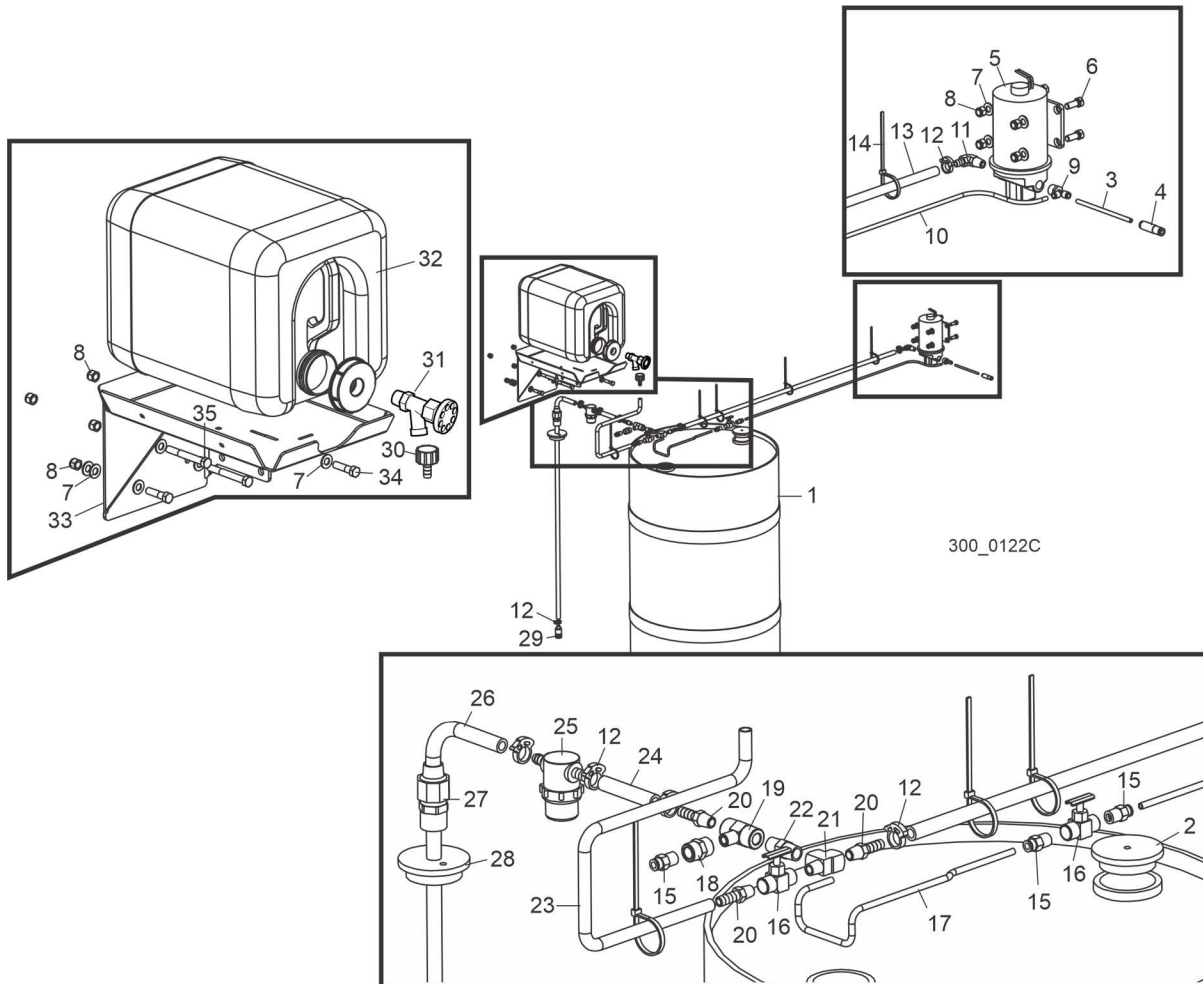

REF	PART #	DESCRIPTION	COMMENTS	QTY.
	016926	<b>LUBE SYSTEM, BLADE</b>		1
<b>1</b>	016784	Barrel, Plastic		1
<b>2</b>	016786	Cap, Barrel Vent		1

**9** **Miscellaneous**  
Lube System

REF	PART #	DESCRIPTION	COMMENTS	QTY.
3	074018	Tube, 1/4" x 100 Ft. Chainflex Pressure	Replaces 016944 1/4" x 107 Ft. Hose (WM3500 Rev. B7.00+). Additional 6 foot of hose supplied for LT300-BX6WM3000-BX6WM3500-BX6. Additional 10 foot of hose supplied for LT300-BX10WM3000-BX10.	1
4	016827	Fitting, 1/4" Tube 6 PSI Check Valve		1
	025249	Cable Assembly, Lube Power		1
	016883	Pump Assembly, Lube		1
5	050029	Pump Assembly, Lube w/Wires		1
6	F05007-87	Bolt, 3/8-16 x 1" Hex Head Grade 5		4
7	F05011-3	Washer, 3/8" Flat		10
8	F05010-10	Nut, 3/8-16 Hex Nylon Lock		8
9	016961	Fitting, 3/8" NPT x 1/4" Tube Male Run Tee		1
10	016885	Hose, 1/4" x 40"		1
11	P12708	Fitting, 3/8" NPT x 3/8" Hose Barb Elbow		1
12	016845	Clamp, Single Snap Grip #38		6
13	016829	Hose, 3/8" x 44"		1
14	F05089-3	Tie Wrap, 3/16" x 5 1/2" UV Black		6
15	P20903	Fitting, 1/4" NPT x 1/4" Tube Straight		3
16	051392	Valve, 1/4" NPT Female Needle		2
17	016886	Hose, 1/4" x 24"		1
18	P03420	Fitting, 1/4" NPT Coupling		1
19	015486	Fitting, 1/4" NPT Branch Tee		1
20	014685	Fitting, 1/4" NPT x 3/8" Hose Barb		3
21	P05382	Fitting, 1/4" NPT Male x 1/4" Female x 2		1
22	P21524	Fitting, 1/4" NPT Nipple		1
23	038495	Hose, 3/8" ID x 25" Tygothane		1
24	038494	Hose, 3/8" x 3"		1
25	033447	Filter, 3/8" Hose Barb Lube		1
	033441	Screen Kit, Mesh Filter		1
	061768	Gasket, Filter Bowl		1
	003198	Bowl, LubeMizer Filter Replacement		1
26	016884	Hose, 3/8" x 40"		1
27	016935	Fitting, 1/2" x 1/2" Compression Coupler		1
28	016785	Cap, Barrel Vent		1
29	016939	Fitting, 3/8" Barb Foot Check Valve		1
30	014113	Fitting, 5/8" NPT x 3/8" Hose Barb		1
31	133320	Valve, 3/4 NPT Elbow 3/4 Male GHT Outlet	Replaced 014100 after 9/19/2024 per ECN 38718.	1
	014100	Valve, 3/4" NPT Elbow PVC		1
	014636	Fitting, 3/4" FPT x 3/4" MPT	Deleted after 9/19/2024 per ECN 38718.	1

REF	PART #	DESCRIPTION	COMMENTS	QTY.
32	014642	Bottle Assembly, Water Lube w/Cap	Use Water Bottle Assembly w/Cap 014642 to service all bottle/cap combinations previously supplied. Bottle 014367, 61mm Cap 014773 and 70mm Cap 036744 no longer available separately.	1
	061372	O-ring, Water Bottle Cap	If the water bottle cap keeps leaking, add this o-ring to the cap. Leave the existing o-ring installed.	1
33	038498	Bracket, Auxiliary Tank Mount		1
34	F05007-78	Bolt, 3/8-16 x 1 1/2" Hex Head Grade 5		2
35	F05007-73	Bolt, 3/16 x 3" Hex Head Grade 5		2



## 9.2 Lube System

LT300Rev. A1.00 - A9.04

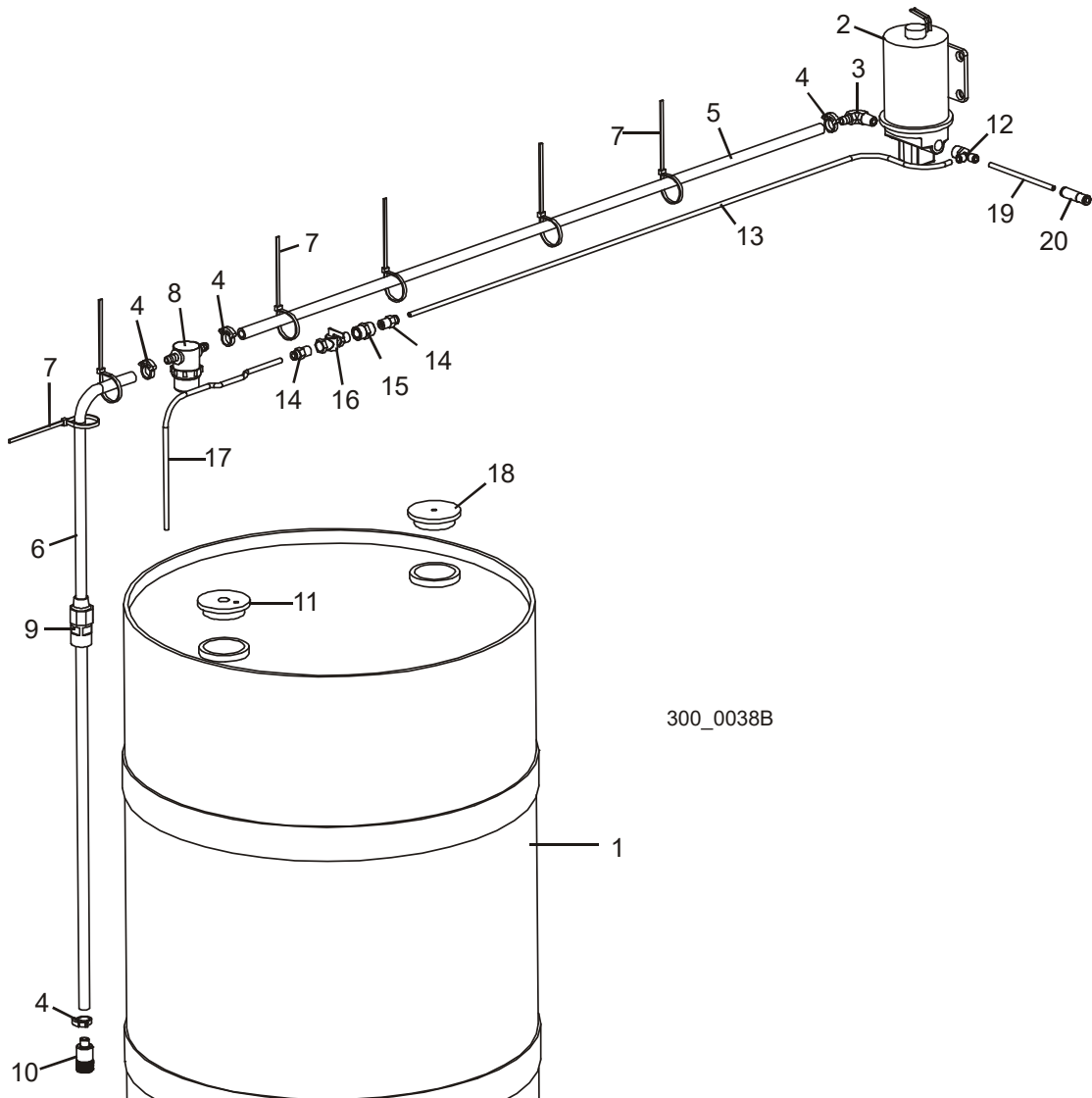

300\_0038B

REF	PART #	DESCRIPTION	COMMENTS	QTY.
	016853	LUBE, 5 GALLON #9 BLADE	Lube replaced with vegetable oil in current lube systems (See Section 9.1 or Section 11.1).	1

REF	PART #	DESCRIPTION	COMMENTS	QTY.
	016926	<b>LUBE SYSTEM, LT300 BLADE</b>	Lube system modified Rev. A9.05 to include auxiliary oil bottle and plumbing to improve blade life and performance. Use retrofit kit 038558 to upgrade previous revisions (See Section 9.1).	1
<b>1</b>	016784	Barrel, Plastic		1
	016883	Pump Assembly, LT300 Lube	Lube system modified Rev. A9.05 to include auxiliary oil bottle and plumbing to improve blade life and performance. Use retrofit kit 038558 to upgrade previous revisions (See Section 9.1).	1
<b>2</b>	050029	Pump Assembly, Lube w/Wires		1
<b>3</b>	P12709	Fitting, 3/8" NPT x 3/8" Hose Barb Elbow		1
<b>4</b>	016845	Clamp, Single Snap Grip #38		4
<b>5</b>	016829	Hose, 3/8" x 44"		1
<b>6</b>	016884	Hose, 3/8" x 40"		1
<b>7</b>	F05089-3	Tie Wrap, 3/16" x 5 1/2" UV Black		6
<b>8</b>	033447	Filter, 3/8" Hose Barb Lube		1
	033441	Screen Kit, Mesh Filter		1
	061768	Gasket, Filter Bowl		1
	003198	Bowl, LubeMizer Filter Replacement		1
<b>9</b>	016935	Fitting, 1/2" x 1/2" Compression Coupler		1
<b>10</b>	016939	Fitting, 3/8" Barb Foot Check Valve		1
<b>11</b>	016785	Cap, Barrel Vent		1
<b>12</b>	016961	Fitting, 3/8" NPT x 1/4" Tube Male Run Tee		1
<b>13</b>	016885	Hose, 1/4" x 40"		1
<b>14</b>	P20903	Fitting, 1/4" NPT x 1/4" Tube Straight		2
<b>15</b>	P03420	Fitting, 1/4" NPT Coupling		1
<b>16</b>	P04669	Fitting, Petcock Valve		1
<b>17</b>	016886	Hose, 1/4" x 24"		1
<b>18</b>	016786	Cap, Barrel Vent		1
<b>19</b>	016944	Hose, 1/4" x 100 Foot	Hose length changed from 60' to 100' to allow remote installation of lube system (2/02). Additional 6 foot of hose supplied for LT300-BX6.	1
<b>20</b>	016827	Fitting, 1/4" Tube 6 PSI Check Valve	Fitting moved from idle side blade guide assembly to lube assembly (Rev. A3.00).	1
	025249	Cable Assembly, Lube Power		1

**9.3 Tools**

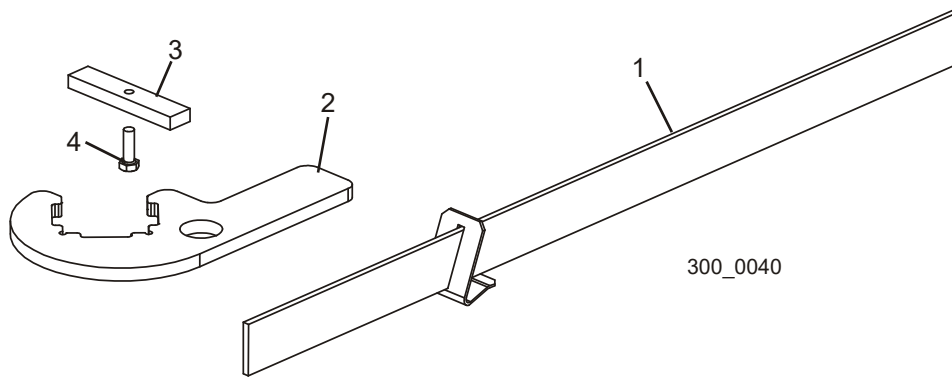

REF	DESCRIPTION (◆ Indicates Parts Available In Assemblies Only)	PART #	QTY.
1	ALIGNMENT TOOL, BLADE GUIDE	LTBGAT	1
2	ALIGNMENT TOOL, BLADE GUIDE ARM	042700	1
3	BLOCK, BLADE GUIDE ALIGNMENT	035799	2
4	BOLT, #10-32 X 5/8" HEX HEAD	F05004-152	2
	HONE, 6" COURSE DIAMOND BENCH SHARPENING (NOT SHOWN)	017813	1

## 9.4 Manuals



REF	DESCRIPTION (◆ Indicates Parts Available In Assemblies Only)	PART #	QTY.	
<b>LT300 Manuals</b>				
1	MANUAL, LT300 OPERATOR'S	M989	1	
2	MANUAL, LT300 PARTS	M991	1	
<b>Option Manuals</b>				
3	MANUAL, INCLINE CONVEYOR OPTION	M1121	1	
4	MANUAL, TD1 TRANSFER DECK OPTION	M1062	1	
5	MANUAL, TD2 TRANSFER DECK OPTION	M1192	1	
6	MANUAL, LD12/LD20 LOG INFEED DECK OPTION	M1120	1	
7	MANUAL, THREE-WAY DECK OPTION	M1208	1	
8	MANUAL, DEBARKER OPTION	M1264	1	
<b>Schematics</b>				
9	SCHEMATIC, LT300 ELECTRICAL	M1014	1	
10	SCHEMATIC, LT300 AIR	M1015	1	

## 9.5 Electrical Harnesses/Cables

LT300

Rev. B4.00+

Description	Model	Part No.	Qty.
<b>Main Electrical Box</b>			
Harness Assembly, Power Feed	w/o Pantograph	050975-1-BXP	1
	w/Pantograph	050975-1-BXP	1
	BX6 w/o Pantograph	050975-1-BXP	1
	BX6 w/Pantograph	050975-1-BXP	1
	BX10 w/Pantograph	050975-BXP	1
Harness Assembly, Up/Down	w/o Pantograph	050976-1-BXP	1
	w/Pantograph	050976-1-BXP	1
	BX6 w/o Pantograph	050976-1-BXP	1
	BX6 w/Pantograph	050976-1-BXP	1
	BX10 w/Pantograph	050976-BXP	1
Harness Assembly, Up/Dn Brake	w/o Pantograph	050977-BXP	1
	w/Pantograph	050977-BXP	1
	BX6 w/o Pantograph	050977-BXP	1
	BX6 w/Pantograph	050977-BXP	1
	BX10 w/Pantograph	050977-BXP	1
Harness Assembly, 25HP Motor	w/o Pantograph	052914-BXP	1
	w/Pantograph	052914-BXP	1
	BX6 w/o Pantograph	052914-BX	1
	BX6 w/Pantograph	052914-BXP	1
	BX10 w/Pantograph	052914-BXP	1
Harness Kit, Blade Motor Therm	All	068202	1
Harness Assembly, Hydraulic Pump	All	052915	1
Cable, Hydraulic Valve Solenoid	All	024923	17
Cable Assembly, Right Joystick	All	025184	1
Cable Assembly, Left Joystick	All	025185	1
Harness Assembly, Head Box	w/o Pantograph	052913-BXP	1
	w/Pantograph	052913-BXP	1
	BX6 w/o Pantograph	052913-BX	1
	BX6 w/Pantograph	052913-BXP	1
	BX10 w/Pantograph	052913-BXP	1
<b>Head Box</b>			
Cable, Blade Brake Release Solenoid	All	025233	1
Cable, Blowoff Valve Solenoid	All	024923	1
Harness Assembly, Blade Guide	All	025284	1
Harness Assembly, Blade Break Prox	All	025286	1
Harness Assembly, Feed Start Prox	All	025287	1
Harness Assembly, Feed Slow Prox	All	025288	1
Harness Assembly, Feed Stop Prox	All	025289	1

LT300 Bed			
Cable Assembly, Transducer	w/o Pantograph	050974	1
	w/Pantograph	050974	1
	BX6 w/o Pantograph	050981	1
	BX6 w/Pantograph	078192	1
	BX10 w/Pantograph	050981-BXP	1
Cable, Up/Down Ballscrew Prox	All	025120	1

## 9.6 Electrical Harnesses/Cables

LT300

Rev. B3.00 - B3.02

Description	Model	Part No.	Qty.
<b>Main Electrical Box</b>			
Harness Assembly, LT300 Power Feed	LT300	050968	1
	LT300-BX6	050975	1
Harness Assembly, LT300 Up/Down	LT300	050969	1
	LT300-BX6	050976	1
Harness Assembly, LT300 Up/Dn Brake	LT300	050970	1
	LT300-BX6	050977	1
Harness Assembly, LT300 25HP Motor	LT300	052914	1
	LT300-BX6	052914-BX	1
Harness Assembly, LT300 Hydraulic Pump	All	052915	1
Cable, Hydraulic Valve Solenoid	All	024923	17
Cable Assembly, Right Joystick	All	025184	1
Cable Assembly, Left Joystick	All	025185	1
Harness Assembly, LT300 Head Box	LT300	052913	1
	LT300-BX6	052913-BX	1
<b>Head Box</b>			
Cable, Blade Brake Release Solenoid	All	025233	1
Cable, Blowoff Valve Solenoid	All	024923	1
Harness Assembly, LT300 Blade Guide	All	025284	1
Harness Assembly, LT300 Blade Break Prox	All	025286	1
Harness Assembly, LT300 Feed Start Prox	All	025287	1
Harness Assembly, LT300 Feed Slow Prox	All	025288	1
Harness Assembly, LT300 Feed Stop Prox	All	025289	1
<b>LT300 Bed</b>			
Cable Assembly, LT300 Transducer	LT300	050974	1
	LT300-BX6	050981	1
Cable, Up/Down Ballscrew Prox	All	025120	1

## 9.7 Electrical Harnesses/Cables

LT300

Rev. A1.00 - B2.02

Description	Model	Part No.	Qty.
<b>Main Electrical Box</b>			
Harness Assembly, LT300 Power Feed	LT300	050968 <sup>1</sup>	1
	LT300-BX6	050975	1
Harness Assembly, LT300 Up/Down	LT300	050969 <sup>1</sup>	1
	LT300-BX6	050976	1
Harness Assembly, LT300 Up/Dn Brake	LT300	050970 <sup>1</sup>	1
	LT300-BX6	050977	1
Harness Assembly, LT300 25HP Motor	LT300	050972 <sup>1</sup>	1
	LT300-BX6	050979	1
Harness Assembly, LT300 Hydraulic Pump	All	025282	1
Cable, Hydraulic Valve Solenoid	All	024923	17
Cable Assembly, Right Joystick	All	025184	1
Cable Assembly, Left Joystick	All	025185	1
Harness Assembly, LT300 Head Box	LT300	050971 <sup>1</sup>	1
	LT300-BX6	050978	1
Harness Assembly, LT300 Bed Wire	LT300	050973 <sup>2</sup>	1
	LT300-BX6	050980 <sup>2</sup>	1
<b>Head Box</b>			
Cable, Blade Brake Release Solenoid	All	025233	1
Cable, Blowoff Valve Solenoid	All	024923	1
Harness Assembly, LT300 Blade Guide	All	025284	1
Harness Assembly, LT300 Blade Break Prox	All	025286	1
Harness Assembly, LT300 Feed Start Prox	All	025287	1
Harness Assembly, LT300 Feed Slow Prox	All	025288	1
Harness Assembly, LT300 Feed Stop Prox	All	025289	1
<b>LT300 Bed</b>			
Cable Assembly, LT300 Transducer	LT300	050974 <sup>1</sup>	1
	LT300-BX6	050981	1
Cable, Up/Down Ballscrew Prox	All	025120 <sup>3</sup>	1

<sup>1</sup> Cable length may be longer than originally supplied on Rev. A1.00 - A4.00 and shorter than originally supplied on Rev. A5.00 - A6.01. Part listed will work for all applications.

<sup>2</sup> Removed with Toe Board Prox Sensors Rev. A6.00. Cable length may be longer than originally supplied on Rev. A1.00 - A4.00 and shorter than originally supplied on Rev. A5.00 - A6.00.

<sup>3</sup> Added with Ballscrew Upgrade Rev. A3.00.



### 9.8 Pantograph Assembly

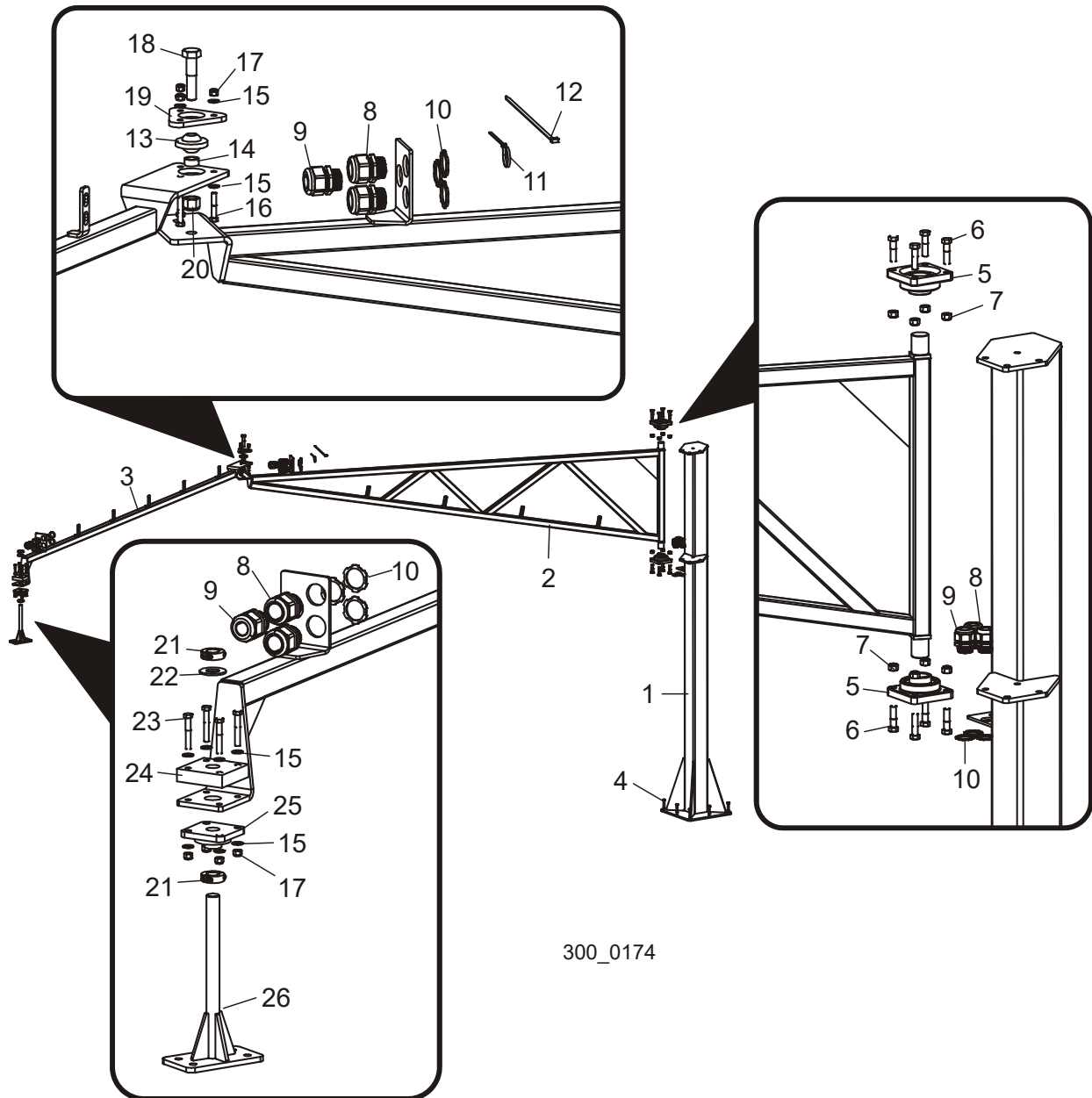

300\_0174

REF	DESCRIPTION (◆ Indicates Parts Available In Assemblies Only)	PART #	QTY.
	<b>PANTOGRAPH RETROFIT, OVERHEAD CABLE</b>	006767 <sup>1</sup>	1
	Pantograph Assembly, Overhead Cable	057475	1
<b>1</b>	Tube Weldment, LT300 Pantograph	057930	1
<b>2</b>	Arm Weldment, LT300 Pantograph A-Frame	057463	1

3	Arm Weldment, LT300 Pantograph Connector	057472	1	
4	Bolt, 1/2" x 5 1/2" Concrete Wedge Anchor	F05008-131	8	
5	Bearing, 1 15/16" 4-Bolt Flange	033712	2	
6	Bolt, 5/8-11 x 2 1/2" Hex Head Grade 5	F05009-20	8	
7	Nut, 5/8-11 Hex Nylon Lock	F05010-34	8	
8	Fitting, .88-1.26" 1 1/4" NPT Cordgrip	057953	6	
9	Fitting, .79-1.00" 1 1/4" NPT Cordgrip	057952	3	
10	Nut, 1 1/4" NPT Conduit Lock	025199	9	
11	Tie Wrap, 3/16" x 6" UV Black	F05089-3	10	
12	Tie Wrap, 5/16" x 15" UV Black	F05089-5	20	
13	Ball Joint, 3/4" ID x 2 1/2" OD	042538	1	
14	Spacer, 25/32" 1 1/8" x 1/2"	057913	1	
15	Washer, 3/8" SAE Flat	F05011-3	14	
16	Bolt, 3/8-16 x 2" Hex Head Grade 8	F05007-124	3	
17	Nut, 3/8-16 Hex Nylon Lock	F05010-10	7	
18	Bolt, 3/4-10 x 3 1/2" Hex Head Grade 5	F05009-54	1	
19	Plate, Ball Joint Retainer	057912	1	
20	Nut, 3/4-10 Hex Nylon Lock	F05010-103	1	
21	Collar, 1" Lock	038444	2	
22	Washer, 1" SAE Flat	F05011-28	1	
23	Bolt, 3/8-16 x 2 1/2" Hex Head Grade 5	F05007-125	4	
24	Block, Bearing Mount	057910	1	
25	Bearing, VF4S-216 Flanged	014090	1	
26	Bracket Weldment, LT300 Pantograph Pivot	057481	1	
	Harness Kit, Pantograph Retrofit	053298	1	
	Harness Assembly, Power Feed	050975-BXP	1	
	Harness Assembly, Up/Down	050976-BXP	1	
	Harness Assembly, Up/Down Brake	050977-BXP	1	
	Bolt, 1/2-13 x 1 1/2" Hex Head Grade 5	F05008-33	4	
	Instructions, Pantograph Retrofit	006767-1579	1	

<sup>1</sup> Pantograph supplied as standard equipment with LT300 beginning with Rev. B4.00. Kit 006806 available to supply wireway/cable carrier previously supplied for customers with space constraints. Use retrofit kit 006767 to add pantograph to LT300 prior to Rev. B4.00 (includes required harnesses).

## 9.9 Vacuum System (Optional) <sup>1</sup>

LT300

Rev. A1.00 - A4.00

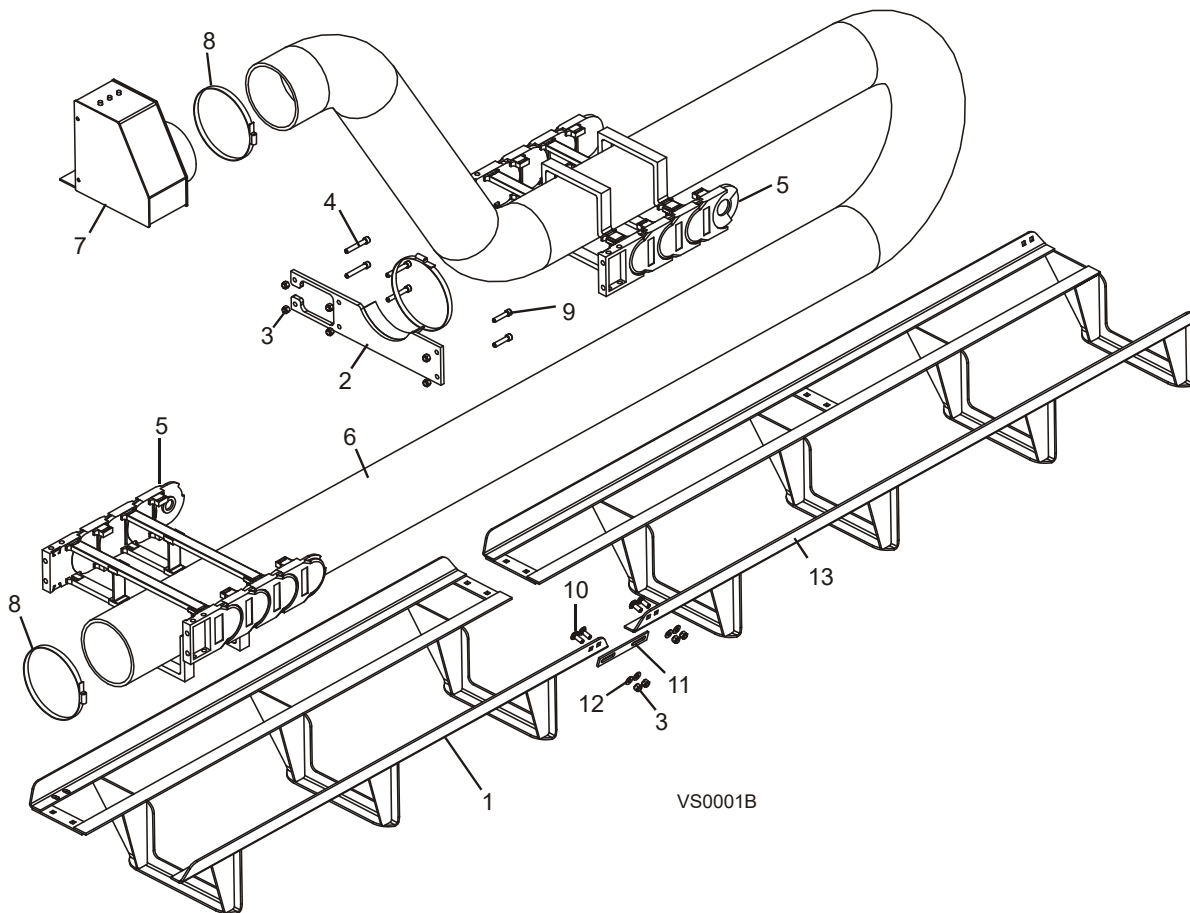

REF	DESCRIPTION (◆ Indicates Parts Available In Assemblies Only)	PART #	QTY.
	<b>VACUUM ASSEMBLY, LT300</b>	VS1 <sup>1</sup>	1
1	Tray Weldment, Vacuum Hose Support 54 13/16"	042849	1
2	Plate Weldment, Vacuum Carrier Adapter	042769	1
3	Nut, 3/8-16 Hex Nylon Lock	F05010-10	10
4	Bolt, 3/8-16 x 2 1/2" Socket Head	F05007-24	4
5	Cable Carrier Parts ( <a href="#">See Section 9.10</a> )		
6	Hose, 6" Vacuum	042704	1
7	Chute Weldment, Vacuum Sawdust	042290	1
8	Clamp, 7" Hose	042767 <sup>2</sup>	3
9	Bolt, 3/8-16 x 1 3/4" Socket Head	F05007-53	2
10	Bolt, 3/8-16 x 1" Carriage Head Grade 5	F05007-165	4

<sup>1</sup> VS1 Vacuum System option discontinued with LT300 Rev. A5.00

<b>11</b>	Plate, Tray Mount	042853	1	
<b>12</b>	Washer, 3/8" SAE Flat	F05011-3	4	
<b>13</b>	Tray Weldment, Vacuum Hose Support 72 3/16"	042851	1	

<sup>1</sup> VS1 Rev. A2.00: Tray weldments 042849 and 042851 replace tray weldment 042299 and Adapter plate weldment 042769 replaces adaptor plate 042288. Longer tray assembly provides additional support for vacuum hose. New adaptor with additional hose clamp prevent hose from working back into mount assembly.

<sup>2</sup> Replaces 042419 supplied prior to VS1 Rev. A1.01. Longer hose clamps required for 6" hose.

**9.10 Vacuum System Cable Carrier (Optional) <sup>1</sup>**

LT300 Rev. A1.00 - A4.00

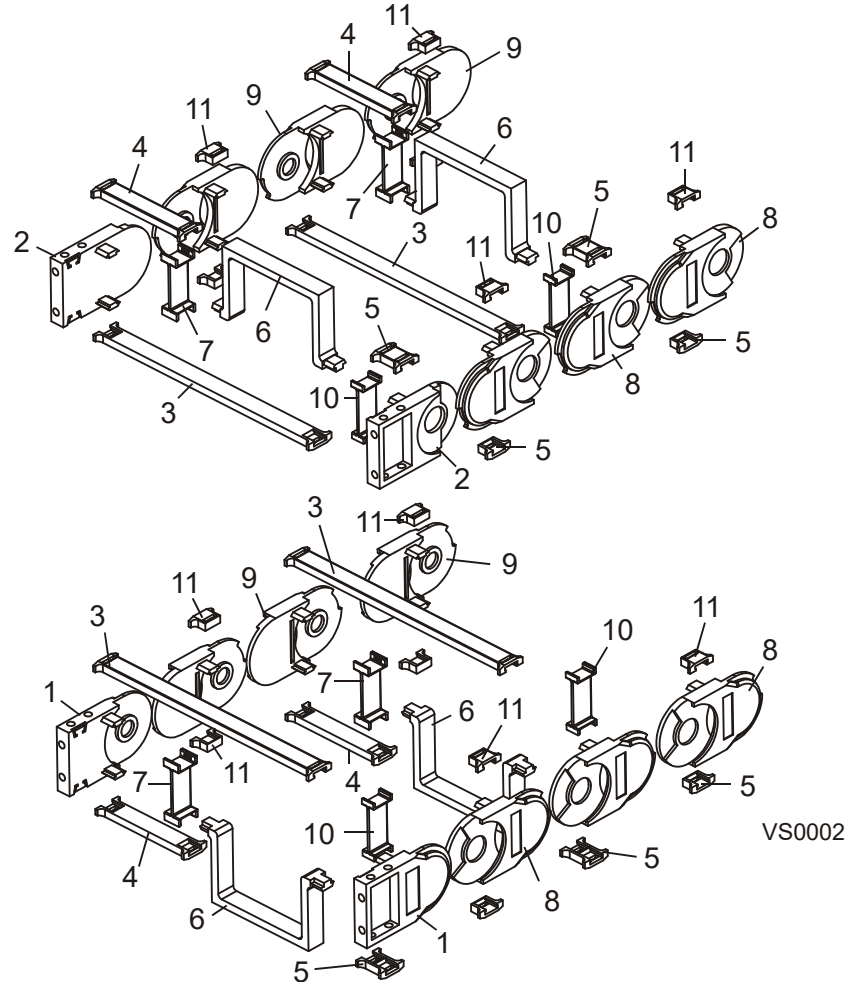

REF	DESCRIPTION (◆ Indicates Parts Available In Assemblies Only)	PART #	QTY.
	<b>CABLE CARRIER, LT300 VACUUM</b>	042703	1
1	Link, 5050 Fixed Side	042710	2
2	Link, 5050 Free Side	042711	2
3	Crossbar, 5050 Long	042712	A/R
4	Crossbar, 5050 Medium	042713	A/R
5	Crossbar, 5050 Short	042714	A/R
6	Crossbar, 5050 Hose	042716	A/R
7	Bar, 5050 Locking Separator	042717	A/R
8	Link, 5050 Right Side	042718	A/R

<sup>1</sup> VS1 Vacuum System option discontinued with LT300 Rev. A5.00

**Miscellaneous** 9  
*Vacuum System Cable Carrier (Optional)*

---

<b>9</b>	Link, 5050 Left Side	042719	A/R	
<b>10</b>	Bar, 5050 Separator	042720	A/R	
<b>11</b>	Bar, Short	023612-5	A/R	

## SECTION 10 OPERATOR STATION

### 10.1 Frame, Rails & Ladder

LT300

Rev. B2.00+

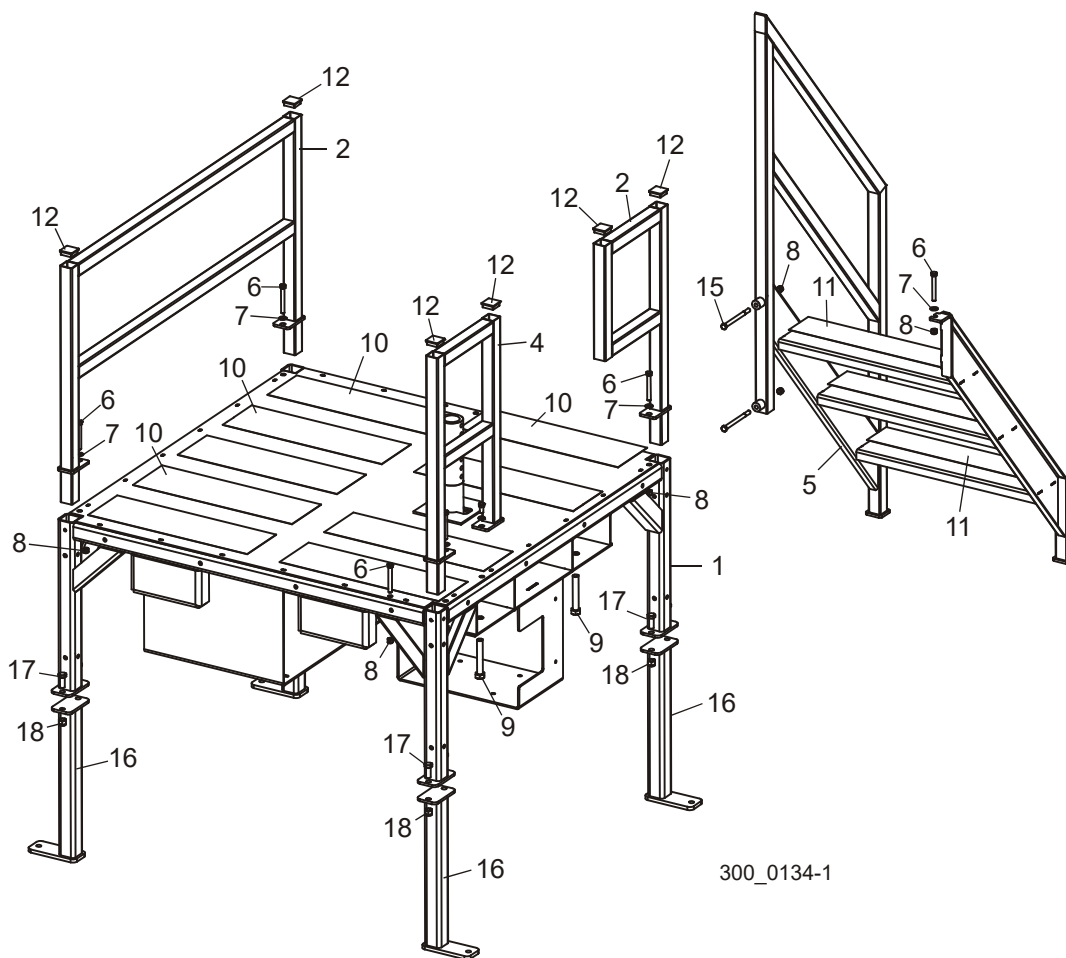

REF	DESCRIPTION (◆ Indicates Parts Available In Assemblies Only)	PART #	QTY.
1	FRAME WELDMENT, OPERATOR STATION	038893	1
2	RAIL WELDMENT, LONG	045118	1
3	RAIL WELDMENT, SHORT	045119	1
4	RAIL WELDMENT, LEFT REAR	036360	1
5	LADDER WELDMENT, OPERATOR STATION	036474	1
6	BOLT, 3/8-16 X 3" HEX HEAD FULL THREAD	F05007-1	6
7	WASHER, 3/8" SAE FLAT	F05011-3	5
8	NUT, 3/8-16 HEX NYLON LOCK	F05010-10	8
9	BOLT, 5/8-11 X 4" HEX HEAD FULL THREAD GRADE 5	F05009-8	2

10	<b>PAD, NON-SKID</b>	045149	15 Ft.	
11	<b>PAD, NON-SKID STEP</b>	016895	3	
12	<b>PLUG, 1 1/2" SQUARE 14 GA. WALL CAP</b>	016843	6	
13	<b>WASHER, 3/8" SPLIT LOCK</b>	F05011-4	1	
14	<b>BOLT, 3/8-16 X 3/4" HEX HEAD GRADE 5</b>	F05007-118	1	
15	<b>BOLT, 3/8-16 X 5" HEX HEAD GRADE 5</b>	F05007-86	2	
	<b>LEG ASSEMBLY, 18" EXTENSION</b>	036461	4	
16	Leg Weldment, Operator Station 18" Extension	051353	1	
17	Bolt, 1/2-13 x 1 1/4" Hex Head Grade 5	F05008-37	2	
18	Nut, 1/2-13 Hex Nylon Lock	F05010-8	2	



### 10.2 Frame, Rails & Ladder

LT300

Rev. A7.00 - B1.01

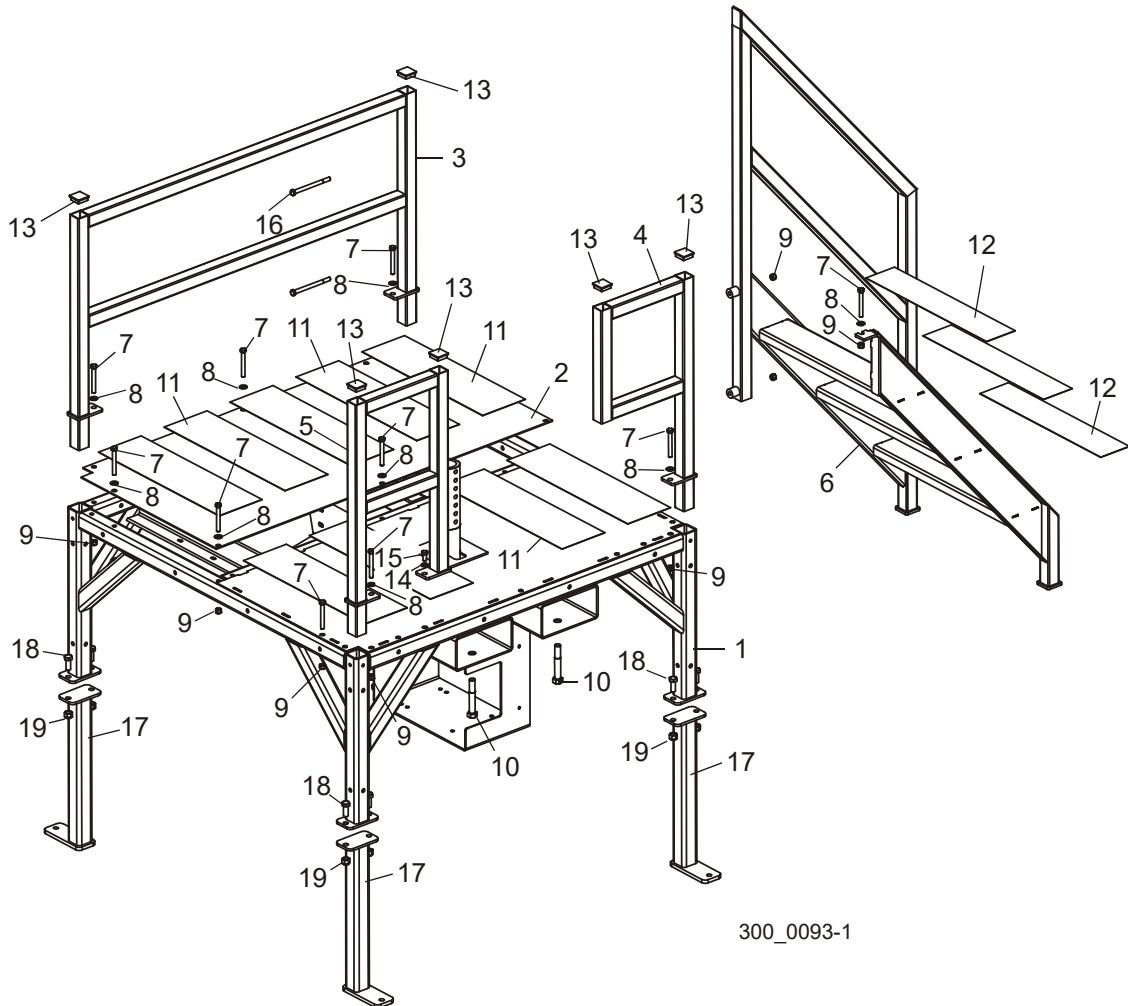

300\_0093-1

REF	DESCRIPTION (◆ Indicates Parts Available In Assemblies Only)	PART #	QTY.
1	FRAME WELDMENT, OPERATOR STATION	045110	1
2	PLATE, WALKWAY	045114	1
3	RAIL WELDMENT, LONG	045118	1
4	RAIL WELDMENT, SHORT	045119	1
5	RAIL WELDMENT, LEFT REAR	036360	1
6	LADDER WELDMENT, OPERATOR STATION	036474	1
7	BOLT, 3/8-16 X 3" HEX HEAD FULL THREAD	F05007-1	10
8	WASHER, 3/8" SAE FLAT	F05011-3	9
9	NUT, 3/8-16 HEX NYLON LOCK	F05010-10	12
10	BOLT, 5/8-11 X 4" HEX HEAD FULL THREAD GRADE 5	F05009-8	2
11	PAD, NON-SKID	045149	15 Ft.

12	<b>PAD, NON-SKID STEP</b>	016895	3	
13	<b>PLUG, 1 1/2" SQUARE 14 GA. WALL CAP</b>	016843	6	
14	<b>WASHER, 3/8" SPLIT LOCK</b>	F05011-4	1	
15	<b>BOLT, 3/8-16 X 3/4" HEX HEAD GRADE 5</b>	F05007-118	1	
16	<b>BOLT, 3/8-16 X 5" HEX HEAD GRADE 5</b>	F05007-86	2	
	<b>LEG ASSEMBLY, 18" EXTENSION</b>	036461	4	
17	Leg Weldment, Operator Station 18" Extension	051353	1	
18	Bolt, 1/2-13 x 1 1/4" Hex Head Grade 5	F05008-37	2	
19	Nut, 1/2-13 Hex Nylon Lock	F05010-8	2	

### 10.3 Frame, Rails & Ladder

LT300

Rev. A1.00 - A6.01

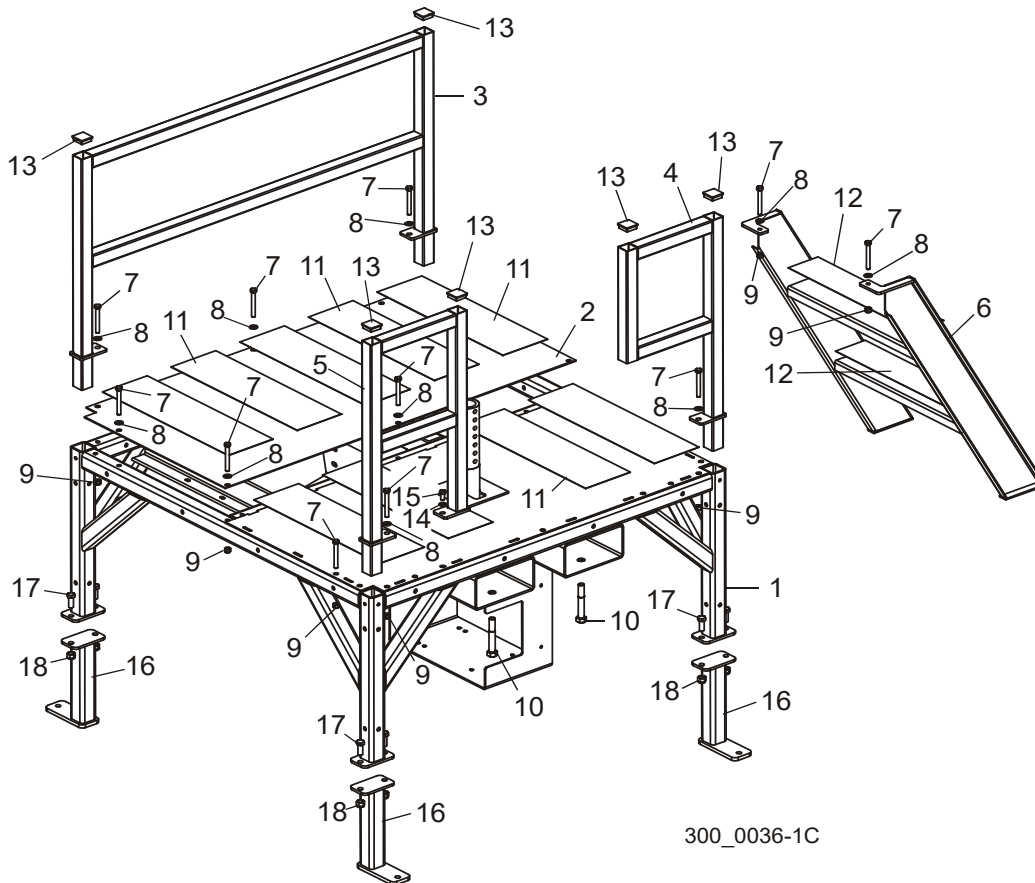

REF	DESCRIPTION (◆ Indicates Parts Available In Assemblies Only)	PART #	QTY.
1	FRAME WELDMENT, OPERATOR STATION	045110	1
2	PLATE, WALKWAY	045114	1
3	RAIL WELDMENT, LONG	045118	1
4	RAIL WELDMENT, SHORT	045119	1
5	RAIL WELDMENT, LEFT REAR	036360 <sup>1</sup>	1
6	LADDER WELDMENT, OPERATOR STATION	045130	1
7	BOLT, 3/8-16 X 3" HEX HEAD FULL THREAD	F05007-1	11
8	WASHER, 3/8" SAE FLAT	F05011-3	10
9	NUT, 3/8-16 HEX NYLON LOCK	F05010-10	11
10	BOLT, 5/8-11 X 4" HEX HEAD FULL THREAD GRADE 5	F05009-8	2
11	PAD, NON-SKID	045149	15 Ft.
12	PAD, NON-SKID STEP	016895	2
13	PLUG, 1 1/2" SQUARE 14 GA. WALL CAP	016843	6

<b>14</b>	<b>WASHER, 3/8" SPLIT LOCK</b>	F05011-4	1	
<b>15</b>	<b>BOLT, 3/8-16 X 3/4" HEX HEAD GRADE 5</b>	F05007-118	1	
	<b>LEG ASSEMBLY, 10" EXTENSION</b>	017783 <sup>2</sup>	4	
<b>16</b>	Leg Weldment, Operator Station 10" Extension	017782	1	
<b>17</b>	Bolt, 1/2-13 x 1 1/4" Hex Head Grade 5	F05008-37	2	
<b>18</b>	Nut, 1/2-13 Hex Nylon Lock	F05010-8	2	

<sup>1</sup> Rail Weldment 036360 replaces one Short Rail Weldment 045119 to accommodate European control box (Rev. A6.01).

<sup>2</sup> Legs changed to two-piece assembly for easier shipping. Foot plates modified to allow drilling of anchor holes with operator station in position.

### 10.4 Seat & Joystick Controls

LT300

Rev. B2.00+

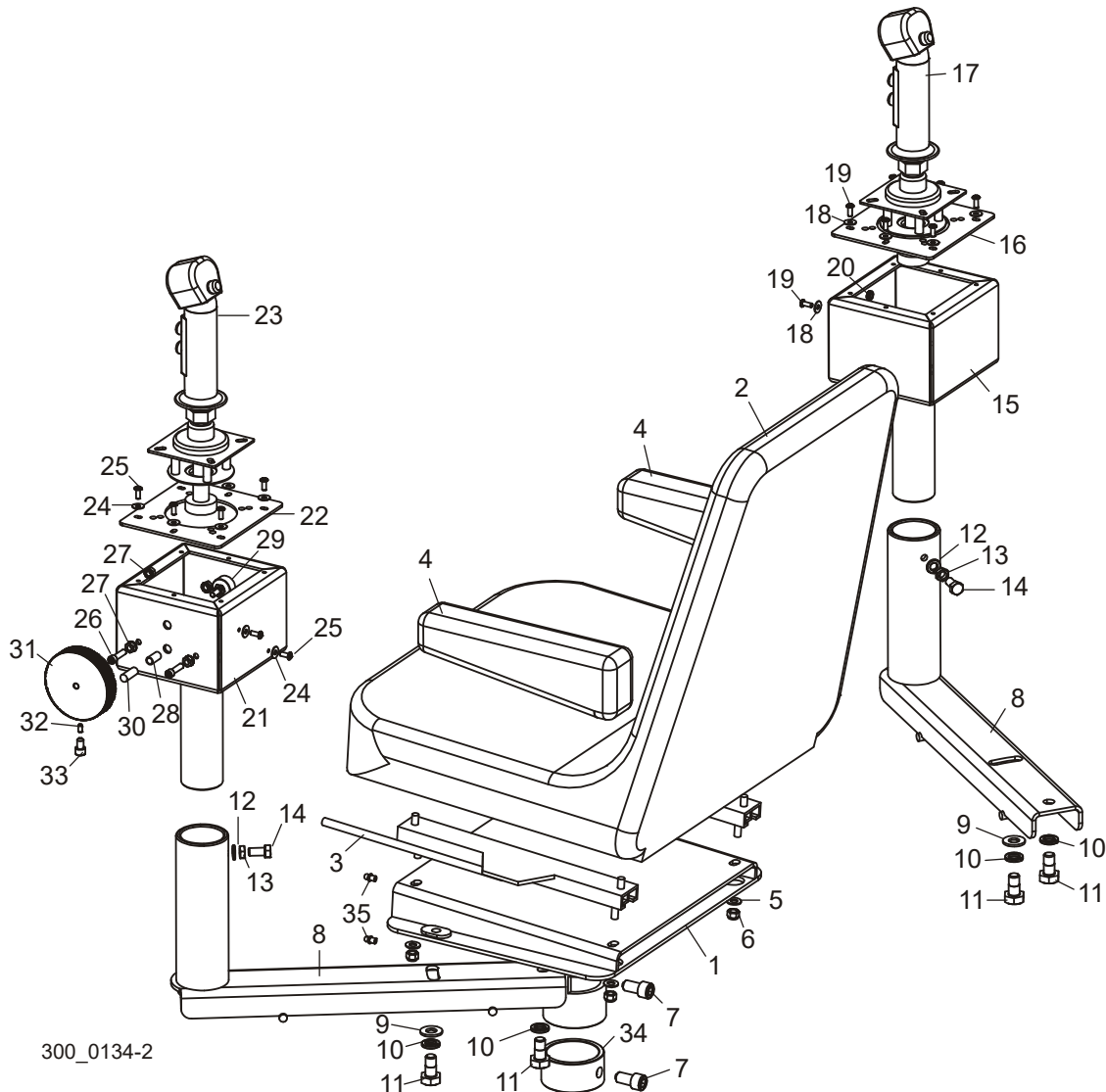

300\_0134-2

REF	DESCRIPTION (◆ Indicates Parts Available In Assemblies Only)	PART #	QTY.
1	MOUNT WELDMENT, OPERATOR SEAT	045134	1
2	SEAT, OPERATOR	038719	1
3	ADJUSTER ASSEMBLY, OPERATOR SEAT (MILSCO)	038720	1
4	ARMREST, OPERATOR SEAT (PAIR, MILSCO)	038721	1
5	WASHER, 5/16" SAE FLAT	F05011-17	4
6	NUT, 5/16-18 NYLON LOCK	F05010-58	4
7	BOLT, 1/2-20 X 1" SOCKET HEAD	F05008-57	2
8	ARM WELDMENT, CONTROL	038857	2

9	<b>WASHER, 1/2" SAE FLAT</b>	F05011-2	2	
10	<b>WASHER, 1/2" SPLIT LOCK</b>	F05011-9	4	
11	<b>BOLT, 1/2-13 X 1" HEX HEAD</b>	F05008-50	4	
12	<b>WASHER, 3/8" SPLIT LOCK</b>	F05011-4	2	
13	<b>NUT, 3/8-16 HEX JAM</b>	F05010-29	2	
14	<b>BOLT, 3/8-16 X 3/4" HEX HEAD GRADE 5</b>	F05007-118	2	
	<b>CONTROL ASSEMBLY, RIGHT JOYSTICK</b>	038865	1	
15	Box Weldment, Right Joystick	038863	1	
16	Cover, Joystick Control Box	038861	1	
17	Joystick, 3-Button Control	036757	1	
	Button, Joystick Press	061192	1	
18	Washer, #10 SAE Flat	F05011-18	7	
19	Screw, #10-24 x 1/2" Socket Button Head	F05004-35	7	
20	Nut, #10-24 Self-Locking Hex	F05010-14	1	
	<b>CONTROL ASSEMBLY, LEFT JOYSTICK</b>	038864	1	
21	Box Weldment, Left Joystick	038862	1	
22	Cover, Joystick Control Box	038861	1	
23	Joystick, 3-Button Control	036757	1	
	Button, Joystick Press	061192	1	
24	Washer, #10 SAE Flat	F05011-18	8	
25	Screw, #10-24 x 1/2" Socket Button Head	F05004-35	8	
26	Bolt, 1/4-20 x 1" Socket Head	F05005-84	2	
27	Nut, 1/4-20 Self-Locking Hex	F05010-9	4	
28	Spring, LC-040E-10SS	P06460	1	
29	Potentiometer Assembly, 4-20mA 24V w/Connectors	025200	1	
30	Pin, Cam Brake	S10663	1	
31	Knob, Speed Control	035559	1	
32	Screw, #10-32 x 3/8" Cup Point Socket Set	F05004-188	1	
33	Bolt, 5/16-18 x 1/2" Socket Head	F05006-39	1	
34	<b>COLLAR, SEAT POST MOUNT</b>	045135	1	
35	<b>FITTING, 1/4-28 GREASE</b>	P05060	2	

### 10.5 Seat & Joystick Controls

LT300

Rev. A1.00 - B1.01

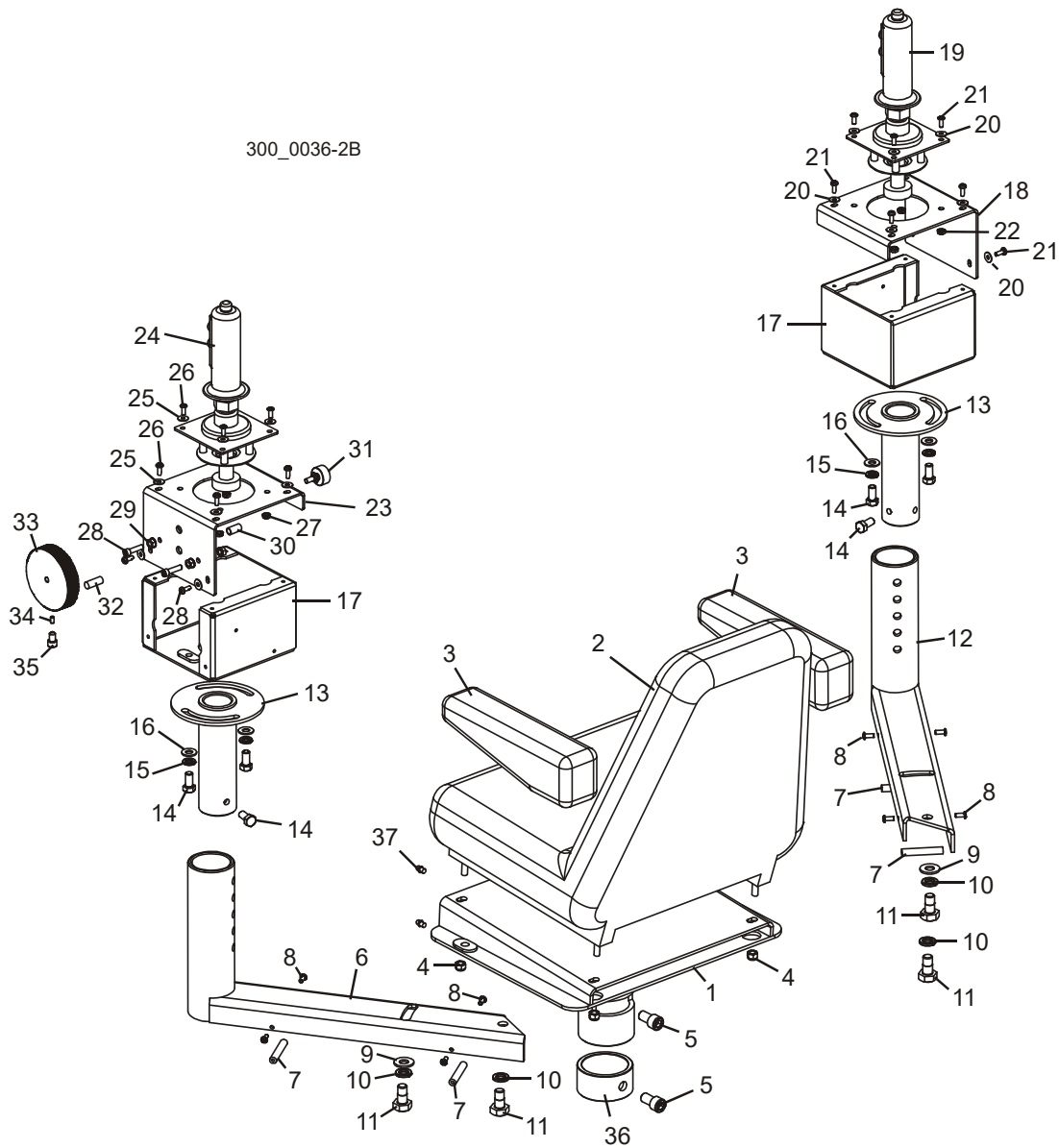

REF	DESCRIPTION (◆ Indicates Parts Available In Assemblies Only)	PART #	QTY.
1	MOUNT WELDMENT, OPERATOR SEAT	045134	1
2	SEAT, OPERATOR	038719 ◆	1
	ADJUSTER ASSEMBLY, OPERATOR SEAT (MILSCO)	038720 ◆	1
	ADJUSTER ASSEMBLY, OPERATOR SEAT	036754 ◆	1
3	ARMREST, OPERATOR SEAT (PAIR, MILSCO)	038721 ◆	1
	ARMREST, OPERATOR SEAT (PAIR)	P26247 ◆	1

4	<b>NUT, 5/16-18 NYLON LOCK</b>	F05010-58	4	
5	<b>BOLT, 1/2-20 X 1" SOCKET HEAD</b>	F05008-57	2	
6	<b>ARM WELDMENT, LEFT CONTROL</b>	045144	1	
7	<b>PIN, HARNESS SUPPORT</b>	045148	4	
8	<b>SCREW, #10-24 X 1/2" SOCKET BUTTON HEAD</b>	F05004-35	8	
9	<b>WASHER, 1/2" SAE FLAT</b>	F05011-2	2	
10	<b>WASHER, 1/2" SPLIT LOCK</b>	F05011-9	4	
11	<b>BOLT, 1/2-13 X 1" HEX HEAD</b>	F05008-50	4	
12	<b>ARM WELDMENT, RIGHT CONTROL</b>	045145	1	
13	<b>TUBE WELDMENT, JOYSTICK MOUNT</b>	042105	2	
14	<b>BOLT, 3/8-16 X 3/4" HEX HEAD GRADE 5</b>	F05007-118	6	
15	<b>WASHER, 3/8" SPLIT LOCK</b>	F05011-4	4	
16	<b>WASHER, 3/8" SAE FLAT</b>	F05011-3	4	
17	<b>BOX WELDMENT, JOYSTICK</b>	042103	2	
	<b>CONTROL ASSEMBLY, RIGHT JOYSTICK</b>	035541 <sup>2</sup>	1	
18	Cover, Joystick Control Box	035542 <sup>2</sup>	1	
19	Joystick, 3-Button Control	036757 <sup>2</sup>	1	
20	Washer, #10 SAE Flat	F05011-18	10	
21	Screw, #10-24 x 1/2" Phillips Head	F05015-17	6	
22	Nut, #10-24 Self-Locking Hex	F05010-14	4	
	<b>CONTROL ASSEMBLY, LEFT JOYSTICK</b>	035547 <sup>2</sup>	1	
23	Cover Weldment, Joystick Control Box	035543 <sup>2</sup>	1	
24	Joystick, 3-Button Control	036757 <sup>2</sup>	1	
25	Washer, #10 SAE Flat	F05011-18	10	
26	Screw, #10-24 x 1/2" Socket Button Head	F05004-35	10	
27	Nut, #10-24 Self-Locking Hex	F05010-14	4	
28	Bolt, 1/4-20 x 1" Socket Head	F05005-84	2	
29	Nut, 1/4-20 Self-Locking Hex	F05010-9	4	
30	Spring, LC-040E-10SS	P06460	1	
31	Potentiometer Assembly, 4-20mA 24V w/Connectors	025200	1	
32	Pin, Cam Brake	S10663	1	
33	Knob, Speed Control	035559	1	
34	Screw, #10-32 x 3/8" Cup Point Socket Set	F05004-118	1	
35	Bolt, 5/16-18 x 1/2" Socket Head	F05006-39	1	
36	<b>COLLAR, SEAT POST MOUNT</b>	045135	1	
37	<b>FITTING, 1/4-28 GREASE</b>	P05060	2	

<sup>1</sup> Replaces P26206 originally supplied before Rev. B1.00 (new vendor). New seat requires adjuster assembly 038720 and arm rest pair 038721. Use 036754 adjuster assembly and P26247 arm rest pair for previous seat.

<sup>2</sup> Joystick assembly modified Rev. A9.03 and then again Rev. A9.05. New joystick 036757 replaced 024942 originally supplied prior to Rev. A9.03 to improve durability. Modified cover required to retrofit previous revisions. Due to failures in the field, joystick was returned to 024942 (Rev. A9.05) until problem can be resolved. Joystick problem resolved Rev. A9.06 and 036757 again replaces 024942.



## 10.6 Air Supply

LT300

Rev. A2.00+

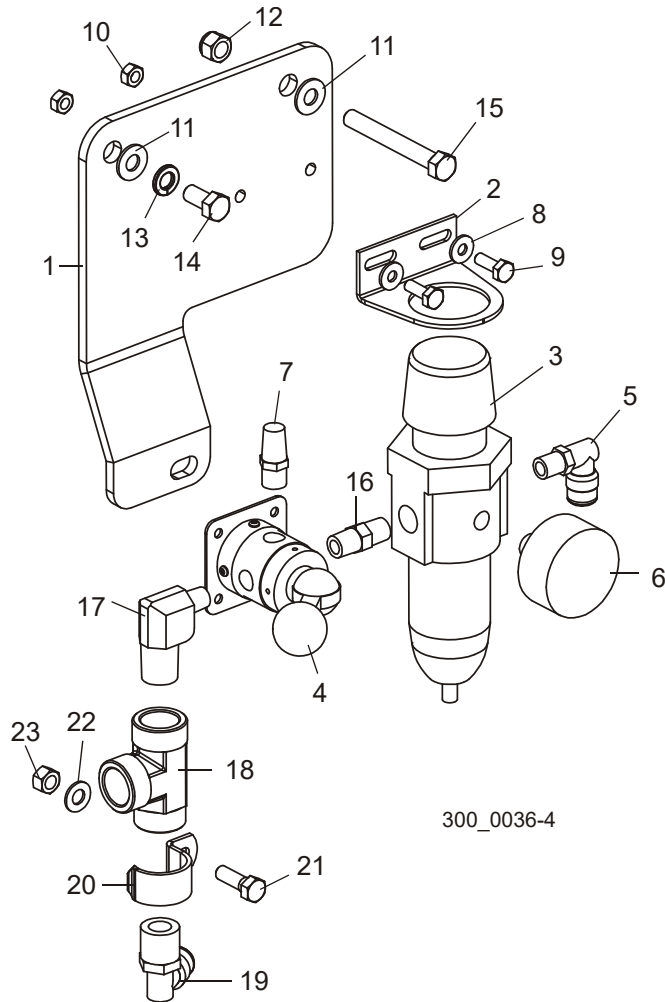

300\_0036-4

REF	DESCRIPTION (◆ Indicates Parts Available In Assemblies Only)	PART #	QTY.
	<b>AIR SUPPLY, LT300</b>	016887	1
1	Plate, Air Supply Mount	016888	1
2	Bracket, Air Filter Mount	P21511	1
3	Filter, B11-02 WJC Regulator	P21510	1
4	Valve, 250V3 Air	P21513	1
5	Fitting, 1/4" NPT x 3/8" Air 90° Elbow	P21521	1
6	Gauge, Air Pressure	P21512	1
7	Fitting, 1/4" NPT Air Muffler	P20904	1
8	Washer, 1/4" SAE Flat	F05011-11	2
9	Bolt, 1/4-20 x 3/4" Hex Head Full Thread	F05005-1	2
10	Nut, 1/4-20 Hex Lock	F05010-21	2

11	Washer, 3/8" SAE Flat	F05011-3	2	
12	Nut, 3/8-16 Nylon Lock	F05010-10	1	
13	Washer, 3/8" Split Lock	F05011-4	1	
14	Bolt, 3/8-16 x 3/4" Hex Head Grade 5	F05007-118	1	
15	Bolt, 3/8-16 x 3" Hex Head Full Thread	F05007-1	1	
16	Fitting, 1/4" Hex Pipe Nipple	P05389	1	
17	Fitting, 1/2" NPT x 1/4" NPT 90° Elbow	016881	1	
18	Fitting, 1/2" NPT Female Tee	016793	1	
19	Fitting, 1/2" NPT x 1/2" Air 90° Elbow	016880	1	
20	Clamp, 1" EMT	P05436	1	
21	Bolt, 5/16-18 x 1" Hex Head	F05006-1	1	
22	Washer, 5/16" SAE Flat	F05011-17	1	
23	Nut, 5/16-18 Hex Lock	F05010-6	1	

### 10.7 Air Supply

LT300

Rev. A1.00 - A1.01

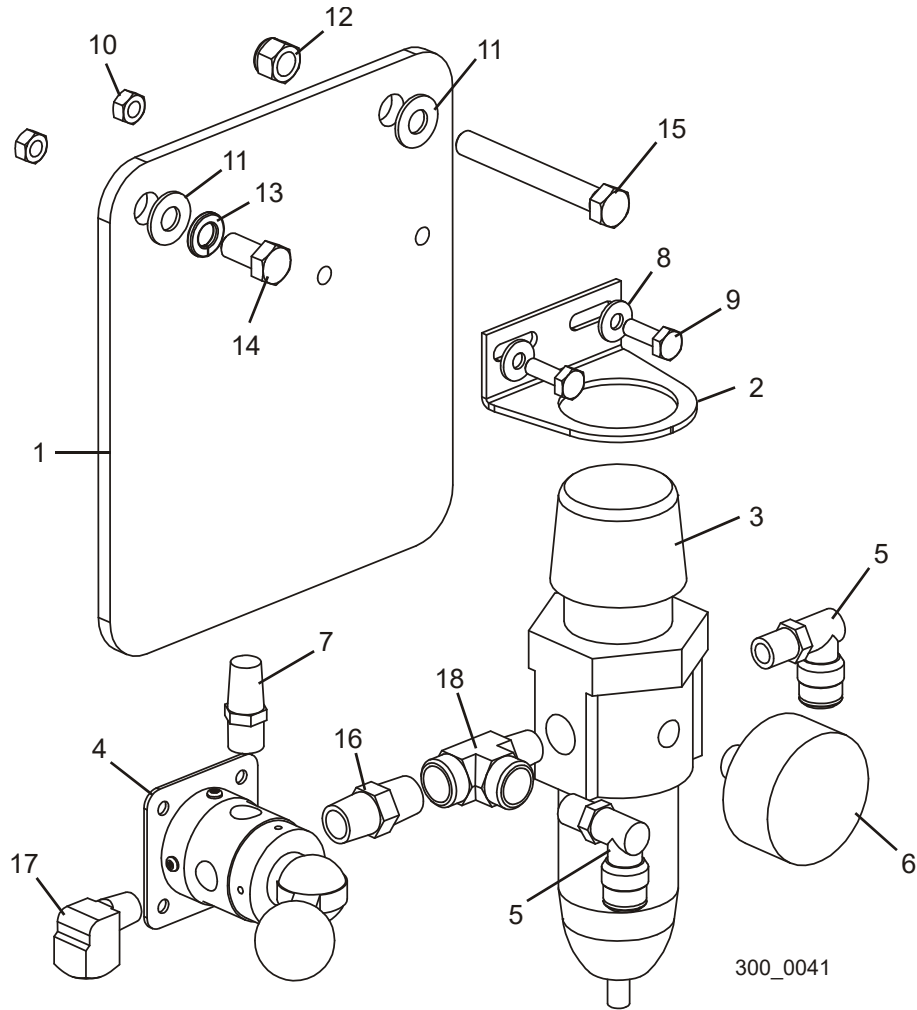

REF	DESCRIPTION (◆ Indicates Parts Available In Assemblies Only)	PART #	QTY.
	<b>AIR SUPPLY, LT300</b>	042572 <sup>1</sup>	1
1	Plate, Air Supply Mount	042571	1
2	Bracket, Air Filter Mount	P21511	1
3	Filter, B11-02 WJC Regulator	P21510	1
4	Valve, 250V3 Air	P21513	1
5	Fitting, 1/4" NPT x 3/8" Air 90° Elbow	P21521	2
6	Gauge, Air Pressure	P21512	1
7	Fitting, 1/4" NPT Air Muffler	P20904	1
8	Washer, 1/4" SAE Flat	F05011-11	2
9	Bolt, 1/4-20 x 3/4" Hex Head Full Thread	F05005-1	2
10	Nut, 1/4-20 Hex Lock	F05010-21	2

11	Washer, 3/8" SAE Flat	F05011-3	2	
12	Nut, 3/8-16 Nylon Lock	F05010-10	1	
13	Washer, 3/8" Split Lock	F05011-4	1	
14	Bolt, 3/8-16 x 3/4" Hex Head Grade 5	F05007-118	1	
15	Bolt, 3/8-16 x 3" Hex Head Full Thread	F05007-1	1	
16	Fitting, 1/4" Hex Nipple	P21524	1	
17	Fitting, 1/4 Brass Street 90° Elbow	P05383	1	
18	Fitting, 1/4" NPT x 1/4" JIC Male Run Tee	P09141	1	

<sup>1</sup> 042572 Air Supply Assembly replaced with 016887 assembly with 1/2" plumbing for blow-off system on LT300 Rev. A2.00+ ([See Section 10.6](#)).

## SECTION 11 PRESSURE LUBE OPTION

### 11.1 Pressure Lube System

LT300/WM3000/WM3500 Rev. A1.00+

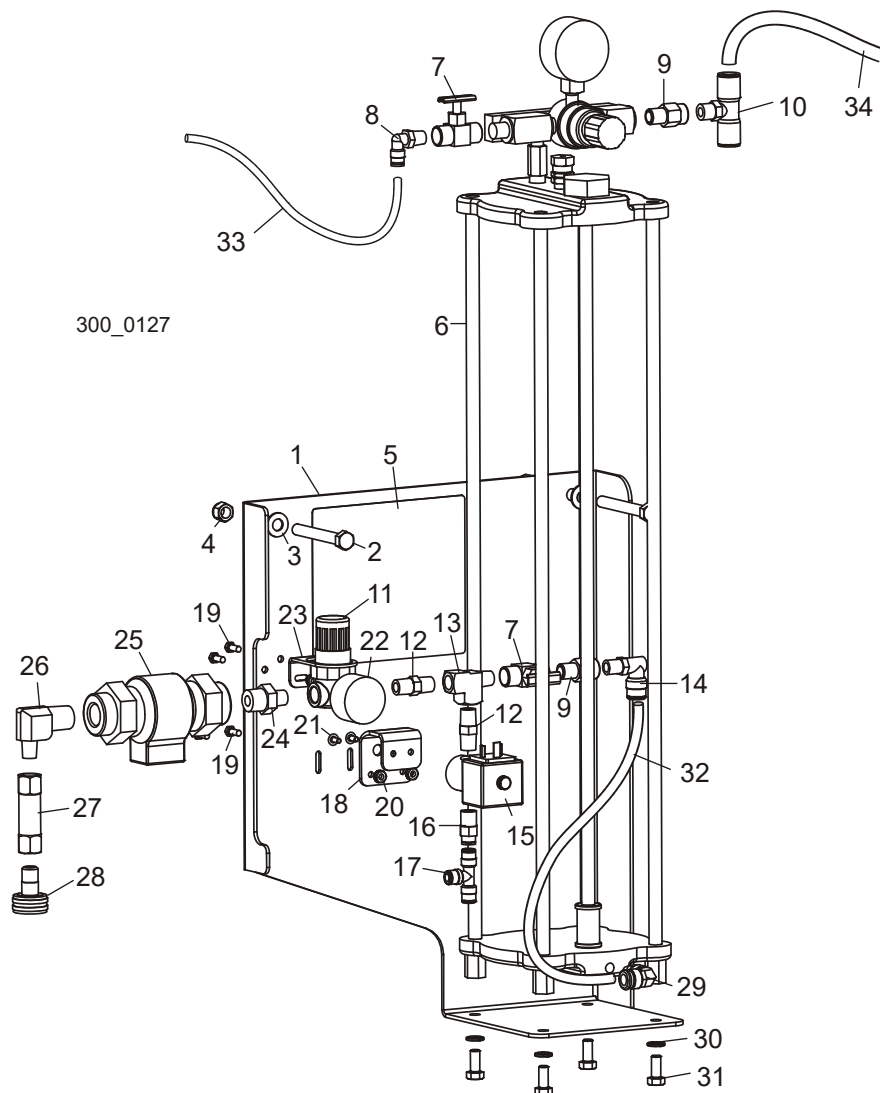

REF	DESCRIPTION (◆ Indicates Parts Available In Assemblies Only)	PART #	QTY.
	<b>LUBE SYSTEM, LT300 OPTIONAL PRESSURE BLADE</b>	051431-A	1
1	Bracket, Pressure Lube Mount	036685	1
2	Bolt, 3/8-16 x 3" Hex Head Full Thread	F05007-1	2
3	Washer, 3/8" SAE Flat	F05011-3	2
4	Nut, 3/8-16 Hex Nylon Lock	F05010-10	2
5	Decal, Pressure Lube Layout	036747	1
6	Reservoir Assembly, Pressure Lube	051434	1

7	Valve, 1/4" NPT Brass Female Needle	051392	2	
8	Fitting, 1/4" NPT x 1/4" Tube 90° Elbow Air	P21519	1	
9	Valve, 1/4" NPT Male-Female Check	051394	2	
10	Fitting, 1/4" NPT x 1/2" Tube Tee	038737	1	
11	Regulator, 1/4" NPT 125 PSI Water	051427	1	
12	Fitting, 1/4" NPT Hex Pipe Nipple	P05389	2	
13	Fitting, 1/4" NPT Female-Male-Female Tee	P05382	1	
14	Fitting, 1/4" NPT x 3/8" Tube 90° Elbow Air	P21521	1	
15	Valve, 1/4" NPT Water NC 2-Way Solenoid	051432	1	
	Cable Assembly, LT300 Lube Pump	052222	1	
16	Fitting, 1/4" NPT x 1/4" Tube Straight Air	P20903	1	
17	Fitting, 1/4" Tube Air Tee	P21544	1	
18	Bracket, Solenoid Mount	036688	1	
19	Screw, #10-24 x 1/2" Unslotted Hex Stainless Steel	F05004-27	4	
20	Nut, #10-24 Self-Locking Hex	F05010-14	4	
21	Screw, #8-32 x 3/8" Round Head Grade 5	F05004-157	2	
22	Gauge, 160 PSI	P02766	1	
23	Bracket, Regulator Mount	051429	1	
24	Fitting, 1/2" NPT x 1/4" NPT Hex Nipple	038484	1	
25	Valve, 1/2" NPT Vacuum Break Dual Check	038483	1	
26	Fitting, 1/2" NPT x 1/4" NPT 90° Elbow	016881	1	
27	Strainer, 1/4" NPT 100 Mesh Inline	051882	1	
28	Fitting, 1/4" NPT x Female Water Hose	051433	1	
29	Fitting, 1/8" NPT x 3/8" Tube 90° Elbow	P21552	1	
30	Washer, 5/16" Split Lock	F05011-13	4	
31	Bolt, 5/16-24 x 3/4" Hex Head Grade 5 Full Thread	F05006-105	4	
32	Tubing, 3/8" Chainflex Air	R01869-4	3 ft.	
33	Tubing, 1/4" Chainflex Air	R01869-3	2 ft.	
34	Tubing, 1/2" Chainflex Air	R01869-5	3 ft.	

## SECTION 12 CAB OPTION

### 12.1 Cab

CAB2

Rev. A1.00+

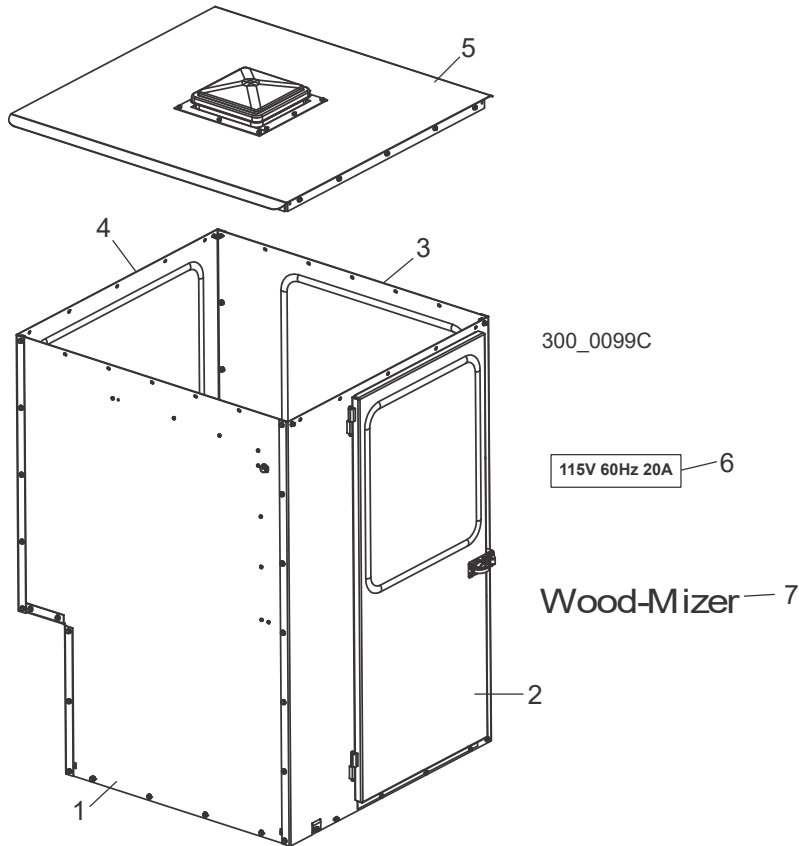

REF	DESCRIPTION (◆ Indicates Parts Available In Assemblies Only)	PART #	QTY.
	<b>CAB OPTION, LT300</b>	CAB2	1
1	Rear Panel Parts ( <a href="#">See Section 12.4</a> )		
2	Right Panel Parts ( <a href="#">See Section 12.6</a> )		
3	Front Panel Parts ( <a href="#">See Section 12.8</a> )		
4	Left Panel Parts ( <a href="#">See Section 12.10</a> )		
5	Roof Parts ( <a href="#">See Section 12.12</a> )		
6	Decal, Cab Voltage	042676	1
7	Decal, Wood-Mizer Logo 15"	052281 <sup>1</sup>	1

<sup>1</sup> Wood-Mizer Logo Decal replaces 052269 AWMV Logo Decal (1/14). 052269 replaces LT300 Logo Decal 016833 (Rev. A1.01)

## 12.2 Cab

CAB1

Rev. A1.00

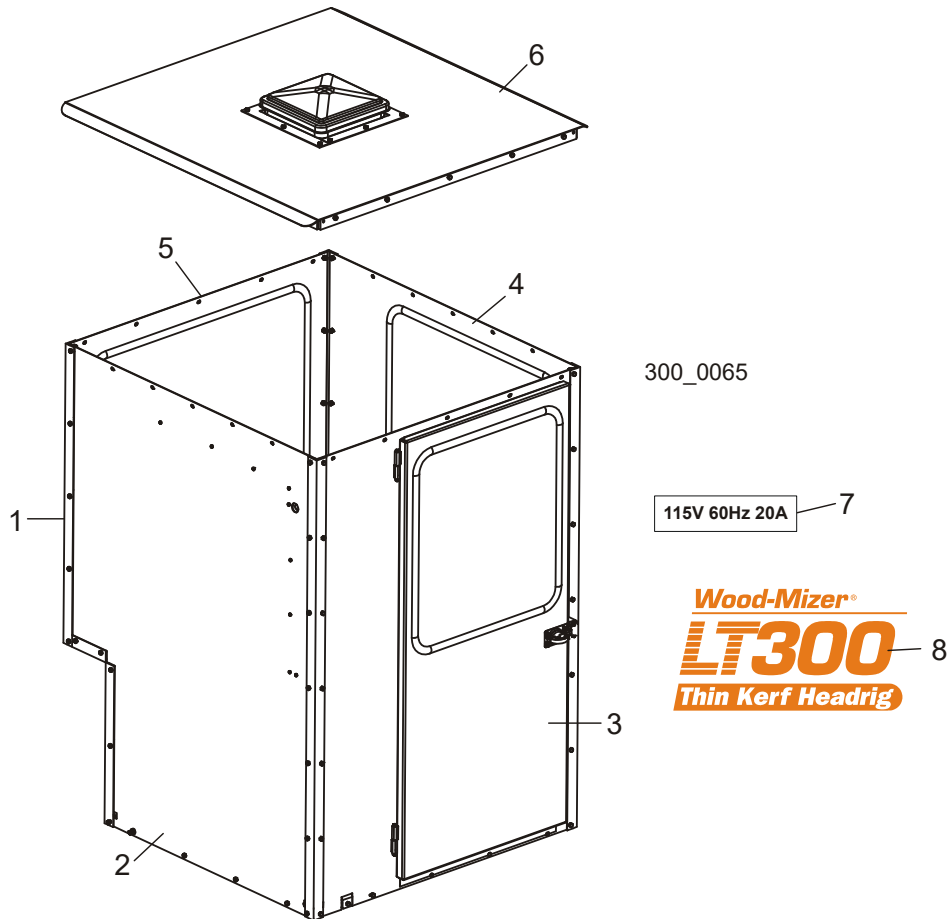

REF	DESCRIPTION (◆ Indicates Parts Available In Assemblies Only)	PART #	QTY.	
	<b>CAB OPTION, LT300</b>	CAB1 <sup>1</sup>	1	◆
1	Frame Parts ( <a href="#">See Section 12.3</a> )			
2	Rear Panel Parts ( <a href="#">See Section 12.5</a> )			
3	Right Panel Parts ( <a href="#">See Section 12.7</a> )			
4	Front Panel Parts ( <a href="#">See Section 12.9</a> )			
5	Left Panel Parts ( <a href="#">See Section 12.11</a> )			
6	Roof Parts ( <a href="#">See Section 12.12</a> )			
7	DECAL, CAB VOLTAGE	042676	1	
8	DECAL, LT300 CAB LOGO	016833	1	

<sup>1</sup> CAB1 obsolete Rev. A8.00. Use CAB2 ([See Section 12.1](#)).



12.3 Frame

CAB1

Rev. A1.00

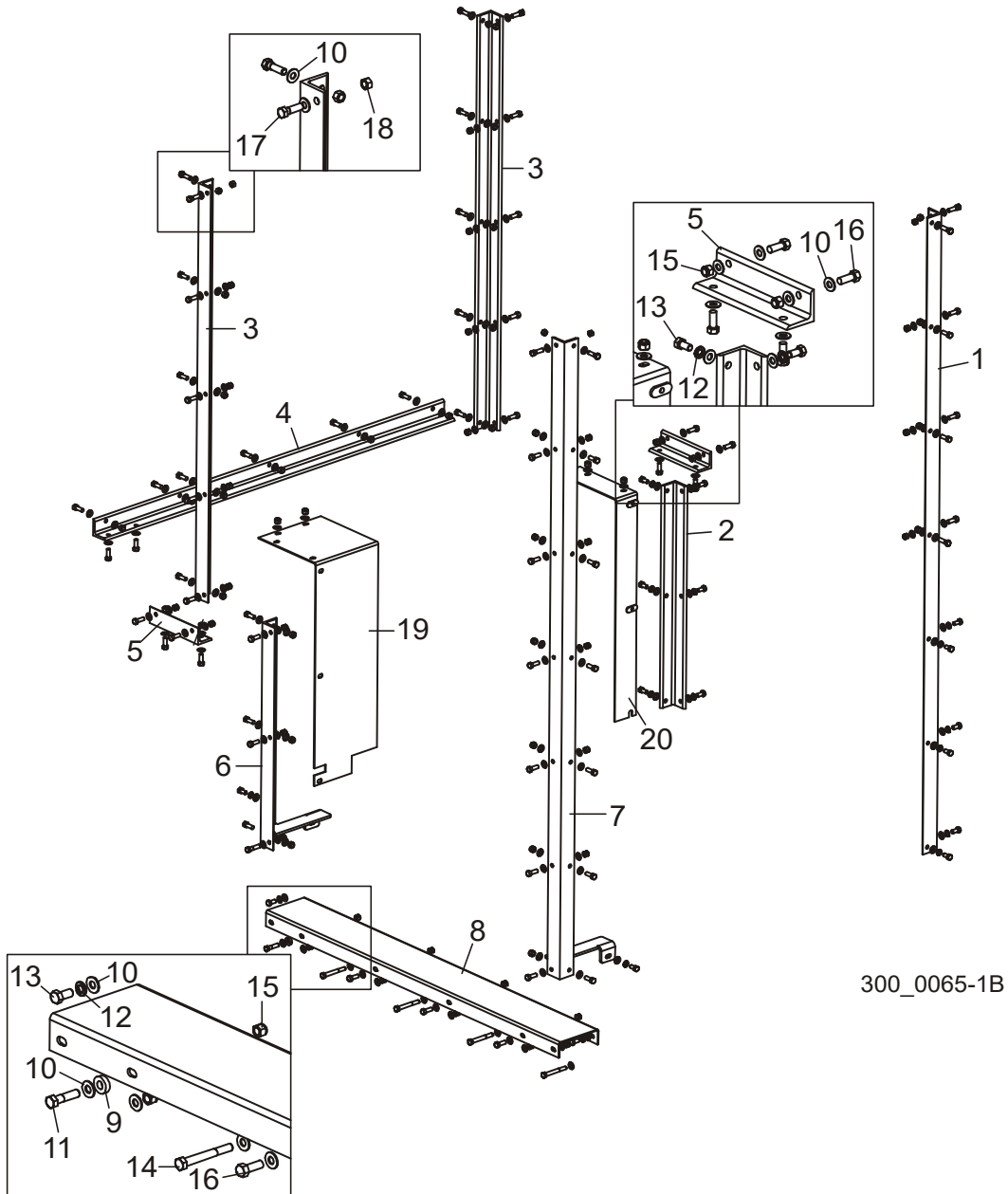

300\_0065-1B

REF	DESCRIPTION (◆ Indicates Parts Available In Assemblies Only)	PART #	QTY.
	<b>FRAME ASSEMBLY, CAB</b>	042605	1
1	Angle, Front Right Frame	042606	1
2	Angle, Front Left Lower Frame	042607	1
3	Angle, Left Upper Frame	042615	2

4	Angle, Left Lower Frame	042617	1	
5	Angle, Left Short Frame	042618	2	
6	Angle Weldment, Rear Left Frame	042610	1	
7	Angle Weldment, Rear Right Frame	042611	1	
8	Channel Weldment, Rear Floor	042628	1	
9	Spacer, 7/8" Diameter	S12284	1	
10	Washer, 3/8" SAE Flat	F05011-3	145	
11	Bolt, 3/8-16 x 1 1/2" Hex Head Grade 5	F05007-78	2	
12	Washer, 3/8" Split Lock	F05011-4	16	
13	Bolt, 3/8-16 x 3/4" Hex Head	F05007-27	16	
14	Bolt, 3/8-16 x 3" Hex Head Grade 5	F05007-73	4	
15	Nut, 3/8-16 Hex Nylon Lock	F05010-10	63	
16	Bolt, 3/8-16 x 1" Hex Head	F05007-7	56	
17	Bolt, 3/8-16 x 1 1/4" Hex Head Grade 5	F05007-123	9	
18	Nut, 3/8-16 Hex Lock	F05010-25	8	
19	<b>PLATE, LOWER LEFT REAR FRAME</b>	042626	1	
20	<b>PLATE WELDMENT, LOWER LEFT FRONT FRAME</b>	042642	1	
	<b>BULB SEAL, C POSITION PEBBLE FINISH</b>	041050	14.79 ft.	
	<b>FOAM, 1/2" X 1" ADHESIVE BACK</b>	R02306	17.5 ft.	

## 12.4 Rear Panel

CAB2

Rev. A1.00+

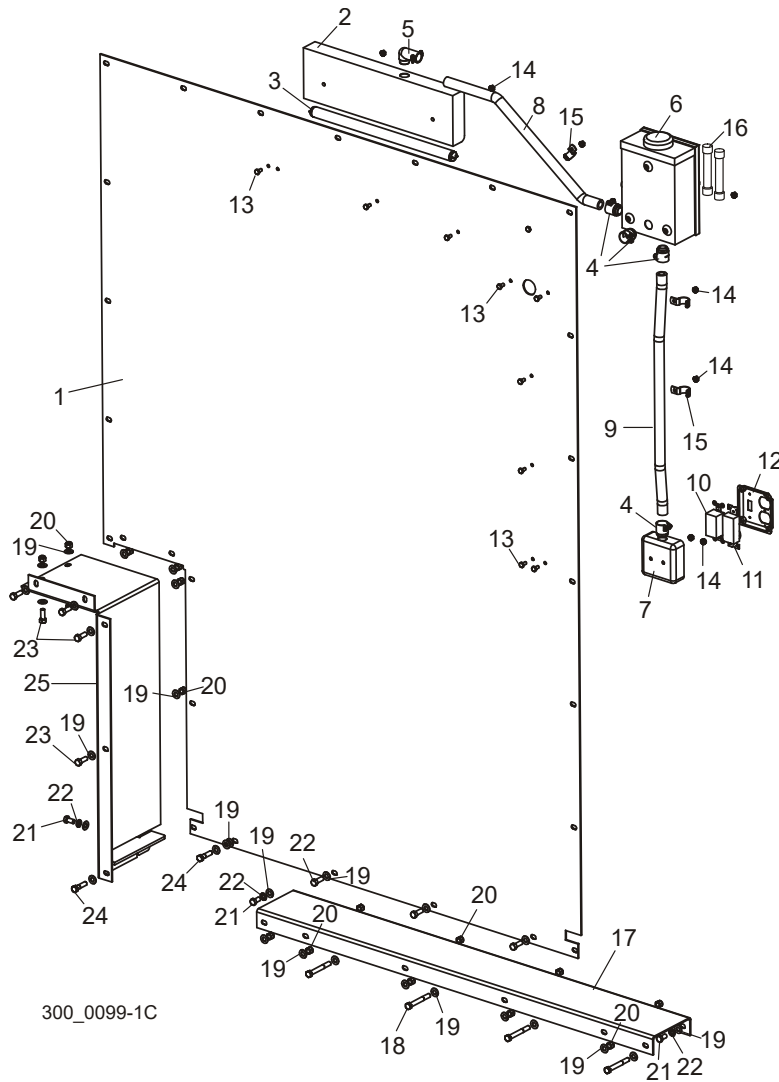

REF	DESCRIPTION (◆ Indicates Parts Available In Assemblies Only)	PART #	QTY.
	<b>PANEL ASSEMBLY, CAB2 REAR</b>	036602	1
1	Panel, Cab2 Rear	036601	1
2	Fixture, Flourescent Uncer-Cabinet Light	042590	1
3	Bulb, 15 Watt Flourescent	016876	1
4	Clamp, 1/2" Flex Conduit	042595	5
5	Clamp, 1/2" 90° Flex Conduit	017801 <sup>1</sup>	1
6	Disconnect Switch, 30A Nema 3R Safety	069553	1
	Ground Bar Kit, Safety Switch (Optional)	069554	1
7	Box, 4" Electrical Utility	042591	1

8	Conduit, 1/2" x 21" Steel Flex	042597 <sup>1</sup>	1	
9	Conduit, 1/2" x 25" Steel Flex	042596	1	
10	Switch, 120VAC 20 Amp Single Pole	042592	1	
11	Receptacle, 120VAC 20 Amp Duplex	042593	1	
12	Cover, Stainless Steel Switch/Plug	042594	1	
13	Bolt, 1/4-20 x 1/2" Hex Head	F05005-15	9	
14	Nut, 1/4-20 Self-Locking Hex	F05010-9	9	
	Wire Nut, Yellow	016863	6	
15	Clamp, 3/4" EMT	P04851	3	
16	Fuse, 20 Amp 250 Volt	E03743	2	
17	<b>CHANNEL WELDMENT, REAR FLOOR</b>	042628	1	
18	<b>BOLT, 3/8-16 X 3" HEX HEAD GRADE 5</b>	F05007-73	4	
19	<b>WASHER, 3/8" SAE FLAT</b>	F05011-3	31	
20	<b>NUT, 3/8-16 HEX NYLON LOCK</b>	F05010-10	15	
21	<b>BOLT, 3/8-16 X 3/4" HEX HEAD</b>	F05007-27	3	
22	<b>WASHER, 3/16" SPLIT LOCK</b>	F05011-4	3	
23	<b>BOLT, 3/8-16 X 1" HEX HEAD</b>	F05007-7	9	
24	<b>BOLT, 3/8-16 X 1 1/2" HEX HEAD GRADE 5</b>	F05007-78	2	
25	<b>PLATE WELDMENT, LOWER LEFT</b>	036591	1	

<sup>1</sup> 017801 clamp replaces one 042595 clamp and conduit 042597 lengthened to improve routing to light fixture (12/04). Conduit length corrected from 22" to 21" (11/05).

### 12.5 Rear Panel

CAB1

Rev. A1.00

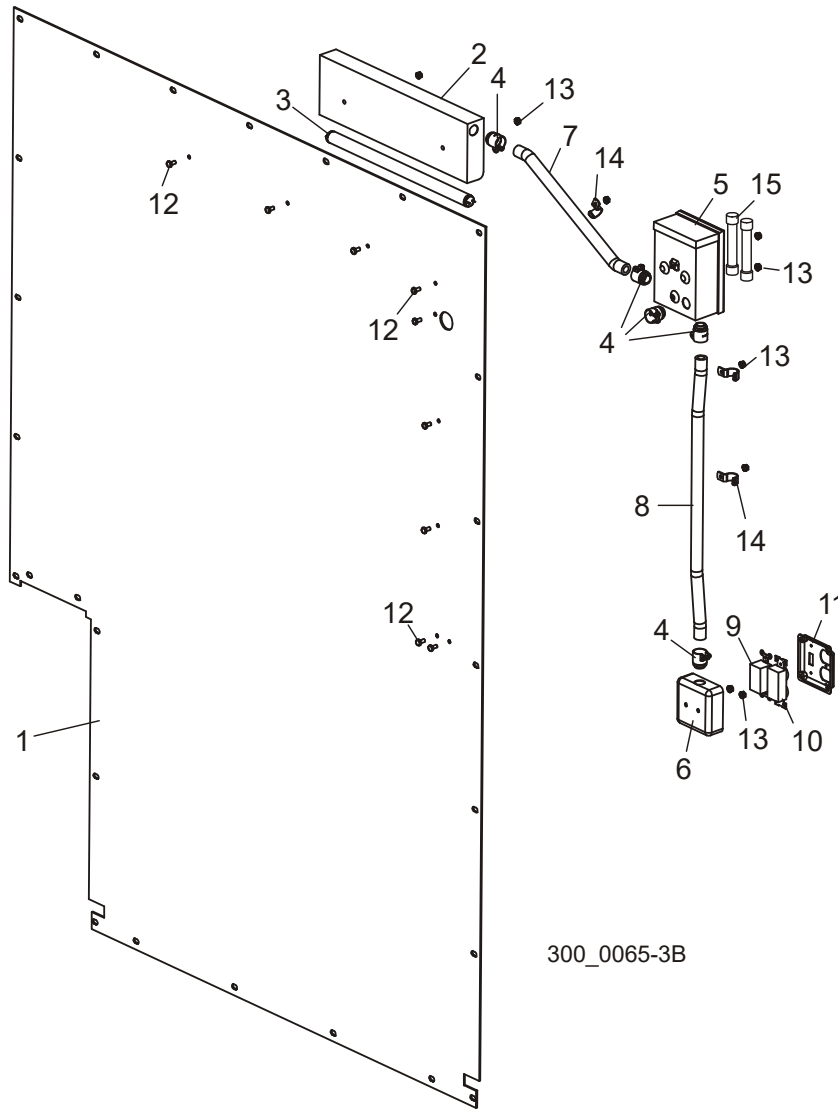

300\_0065-3B

REF	DESCRIPTION (◆ Indicates Parts Available In Assemblies Only)	PART #	QTY.
	<b>PANEL ASSEMBLY, CAB REAR</b>	042604	1
1	Panel, Cab Rear	042613	1
2	Fixture, Flourescent Uncer-Cabinet Light	042590	1
3	Bulb, 15 Watt Flourescent	016876	1
4	Clamp, 1/2" Flex Conduit	042595	5
5	Disconnect Box, Fusible 2-Wire 240V 30A	042589	1
6	Box, 4" Electrical Utility	042591	1
7	Conduit, 1/2" x 16" Steel Flex	042597	1

<b>8</b>	Conduit, 1/2" x 25" Steel Flex	042596	1	
<b>9</b>	Switch, 120VAC 20 Amp Single Pole	042592	1	
<b>10</b>	Receptacle, 120VAC 20 Amp Duplex	042593	1	
<b>11</b>	Cover, Stainless Steel Switch/Plug	042594	1	
<b>12</b>	Bolt, 1/4-20 x 1/2" Hex Head	F05005-15	9	
<b>13</b>	Nut, 1/4-20 Self-Locking Hex	F05010-9	9	
	Wire Nut, Yellow	016863	4	
<b>14</b>	Clamp, 3/4" EMT	P04851	3	
<b>15</b>	Fuse, 20 Amp 250 Volt	E03743	2	

### 12.6 Right Panel

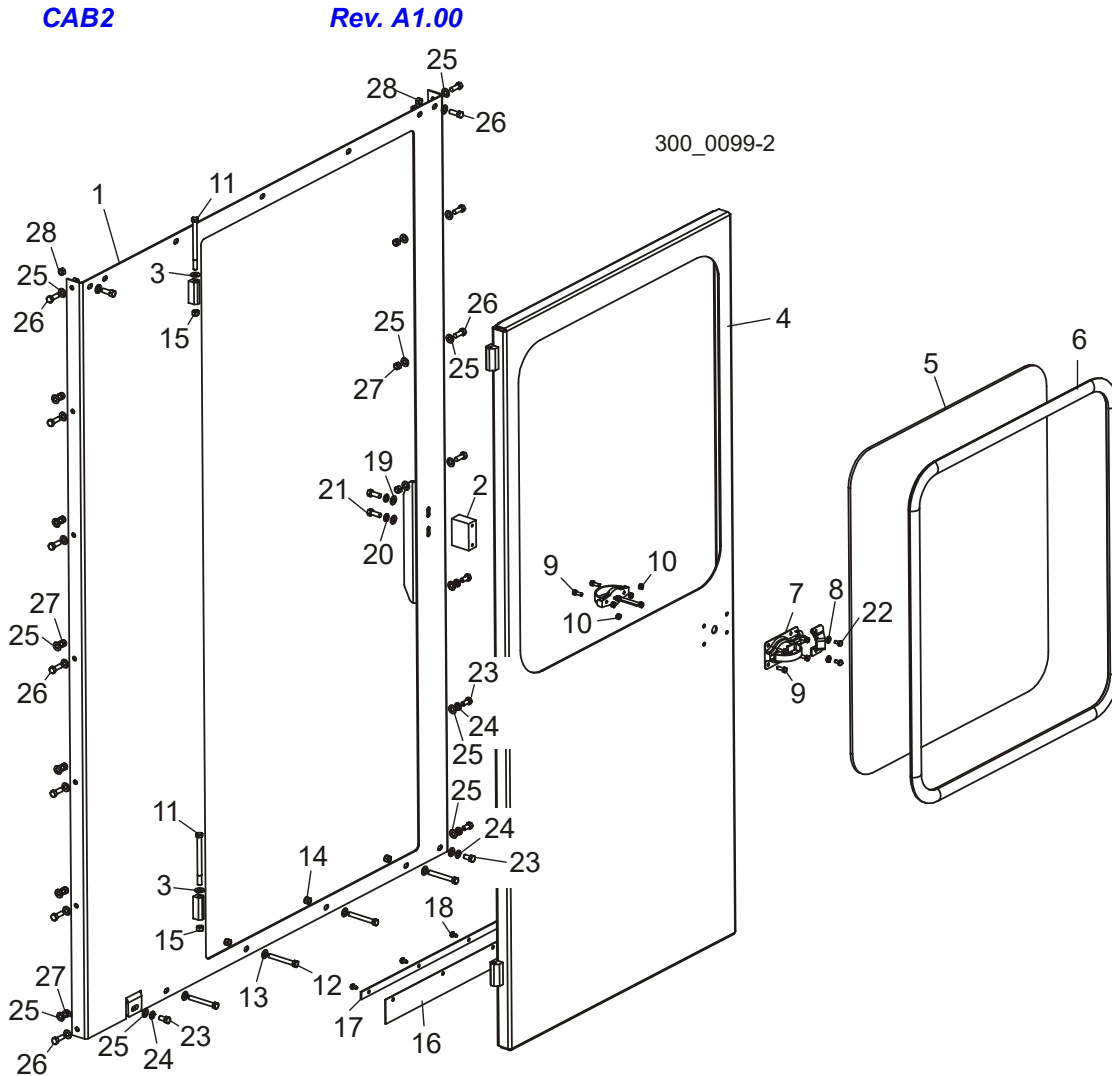

REF	DESCRIPTION (◆ Indicates Parts Available In Assemblies Only)	PART #	QTY.
	<b>PANEL ASSEMBLY, CAB2 RIGHT</b>	036586	1
1	Panel Weldment, Cab2 Right	036585	1
2	Block, Latch Mount	042634	1
3	Washer, Door Hinge	042578	1
4	Door Weldment, Cab	042632	1
5	Window, Cab Door	042576	1
6	Seal, Cab Door Window	042575	1
7	Latch, Door	042587	1
8	Washer, 1/4" Split Lock	F05011-14	2
9	Bolt, 1/4-20 x 3/4" Hex Head Full Thread	F05005-1	6
10	Nut, 1/4-20 Hex Lock	F05010-21	6

11	Bolt, 3/8-16 x 5" Hex Head Grade 5	F05007-86	2	
12	Bolt, 3/8-16 x 3" Hex Head Full Thread	F05007-1	4	
13	Washer, 3/8" SAE Flat	F05011-3	4	
14	Nut, 3/8-16 Hex Nylon Lock	F05010-10	4	
15	Nut, 3/8-16 Hex Lock	F05010-25	2	
16	Flap, Rubber Door	042638	1	
17	Plate, Rubber Door Flap	042637	1	
18	Screw, 1/4-20 x 1/2" Self-Tapping	F05015-1	5	
19	Washer, 3/8" SAE Flat	F05011-3	2	
20	Washer, 3/8" Split Lock	F05011-4	2	
21	Bolt, 3/8-16 x 1" Hex Head	F05007-7	2	
22	Bolt, 1/4-20 x 1/2" Hex Head	F05005-15	2	
23	<b>BOLT, 3/8-16 X 3/4" HEX HEAD</b>	F05007-27	5	
24	<b>WASHER, 3/8" SPLIT LOCK</b>	F05011-4	5	
25	<b>WASHER, 3/8" SAE FLAT</b>	F05011-3	27	
26	<b>BOLT, 3/8-16 X 1" HEX HEAD</b>	F05007-7	13	
27	<b>NUT, 3/8-16 HEX NYLON LOCK</b>	F05010-10	9	
28	<b>NUT, 3/8-16 HEX LOCK</b>	F05010-25	4	



### 12.7 Right Panel

CAB1

Rev. A1.00

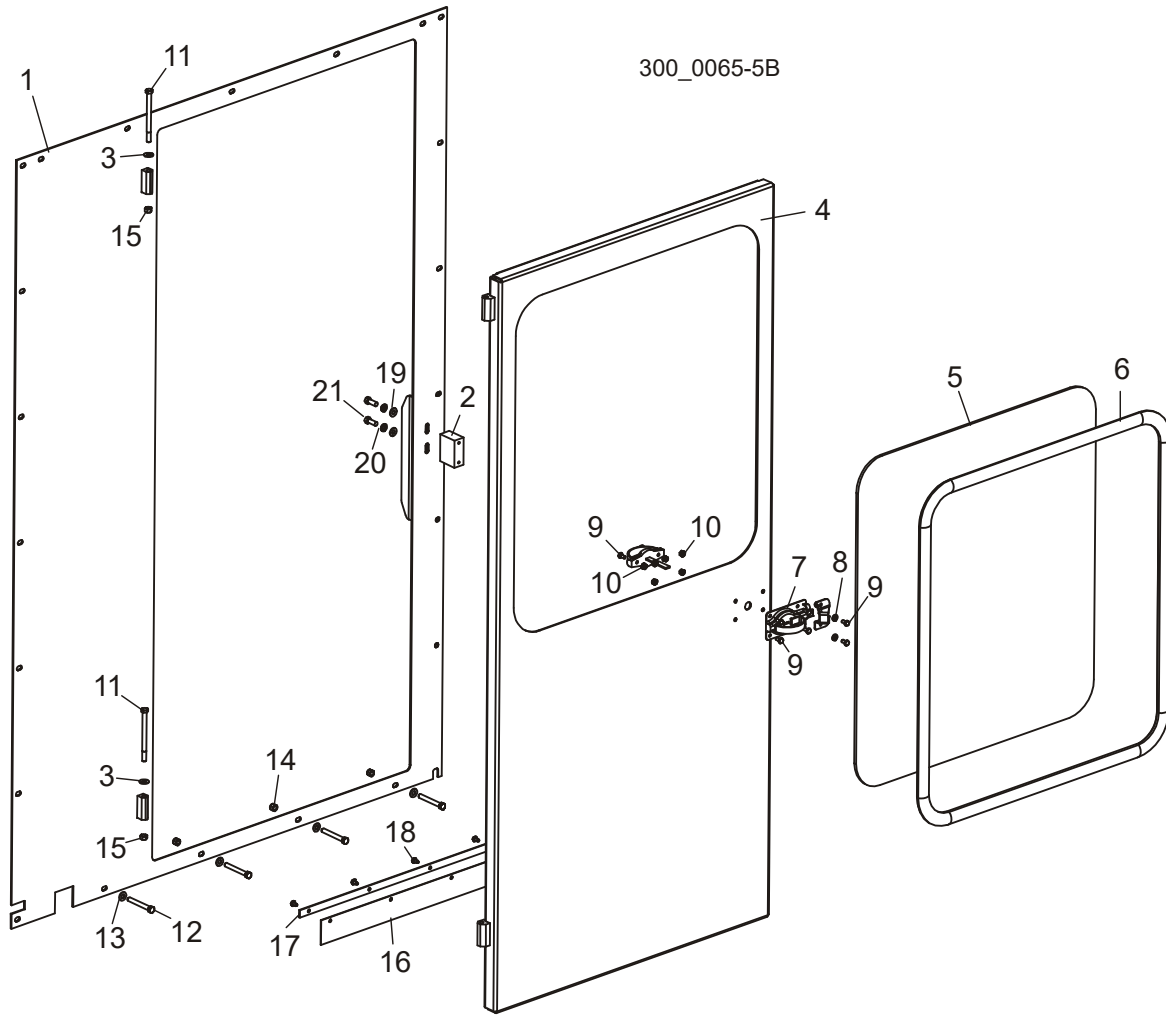

REF	DESCRIPTION (◆ Indicates Parts Available In Assemblies Only)	PART #	QTY.
	<b>PANEL ASSEMBLY, CAB RIGHT</b>	042602	1
1	Panel Weldment, Cab Right	042633	1
2	Block, Latch Mount	042634	1
3	Washer, Door Hinge	042578	1
4	Door Weldment, Cab	042632	1
5	Window, Cab Door	042576	1
6	Seal, Cab Door Window	042575	1
7	Latch, Door	042587	1
8	Washer, 1/4" Split Lock	F05011-14	2
9	Bolt, 1/4-20 x 1/2" Hex Head	F05005-15	8
10	Nut, 1/4-20 Self-Locking Hex	F05010-9	6

11	Bolt, 3/8-16 x 5" Hex Head Grade 5	F05007-86	2	
12	Bolt, 3/8-16 x 3" Hex Head Full Thread	F05007-1	4	
13	Washer, 3/8" SAE Flat	F05011-3	4	
14	Nut, 3/8-16 Hex Nylon Lock	F05010-10	4	
15	Nut, 3/8-16 Hex Lock	F05010-25	2	
16	Flap, Rubber Door	042638	1	
17	Plate, Rubber Door Flap	042637	1	
18	Screw, 1/4-20 x 1/2" Self-Tapping	F05015-1	5	
19	Washer, 3/8" SAE Flat	F05011-3	2	
20	Washer, 3/8" Split Lock	F05011-4	2	
21	Bolt, 3/8-16 x 1" Hex Head	F05007-7	2	

## 12.8 Front Panel

CAB2

Rev. A1.00

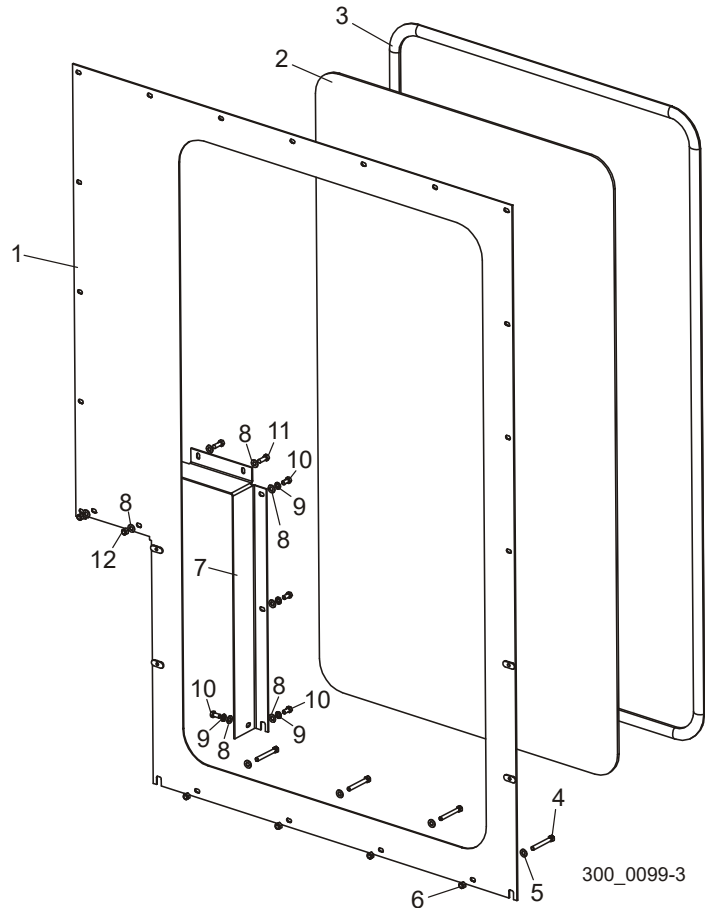

REF	DESCRIPTION (◆ Indicates Parts Available In Assemblies Only)	PART #	QTY.
	<b>PANEL ASSEMBLY, CAB2 FRONT</b>	036605	1
1	Panel Weldment, Cab2 Front	036604	1
2	Window, Cab Front	042631	1
3	Seal, Cab Front Window	042630	1
4	Bolt, 3/8-16 x 3" Hex Head Full Thread	F05007-1	4
5	Washer, 3/8" SAE Flat	F05011-3	4
6	Nut, 3/8-16 Hex Nylon Lock	F05010-10	4
7	<b>PANEL, RIGHT LOWER</b>	036590	1
8	<b>WASHER, 3/8" SAE FLAT</b>	F05011-3	8
9	<b>WASHER, 3/8" SPLIT LOCK</b>	F05011-4	4
10	<b>BOLT, 3/8-16 X 3/4" HEX HEAD</b>	F05007-27	4
11	<b>BOLT, 3/8-16 X 1" HEX HEAD</b>	F05007-7	2
12	<b>NUT, 3/8-16 HEX NYLON LOCK</b>	F05010-10	2

## 12.9 Front Panel

CAB1

Rev. A1.00

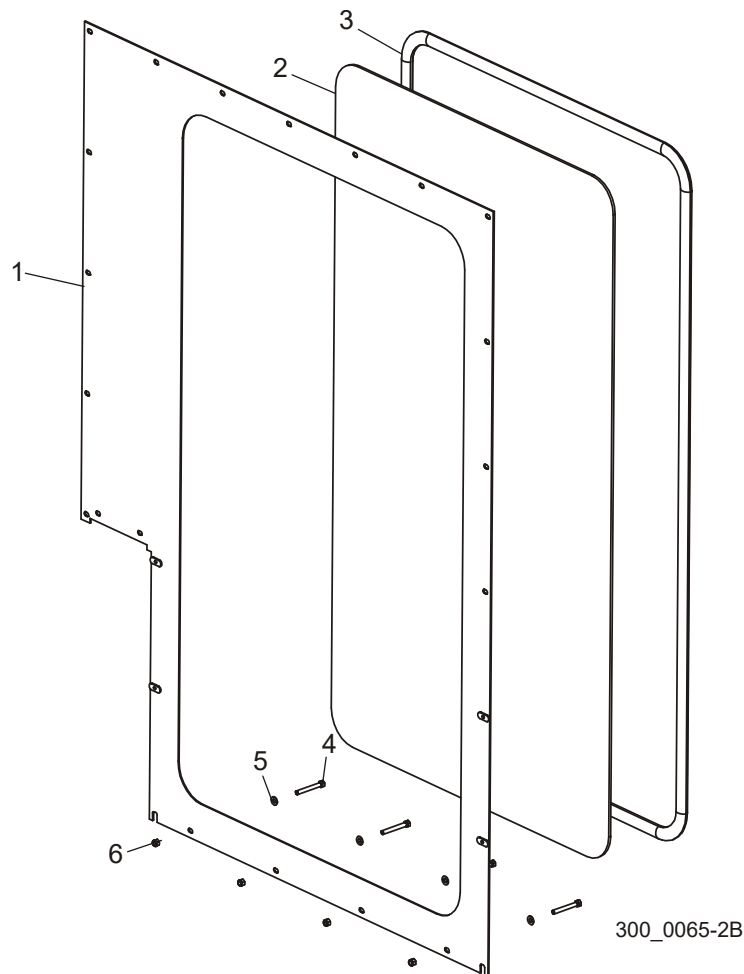

REF	DESCRIPTION (◆ Indicates Parts Available In Assemblies Only)	PART #	QTY.
	<b>PANEL ASSEMBLY, CAB FRONT</b>	042601	1
1	Panel Weldment, Cab Front	042641	1
2	Window, Cab Front	042631	1
3	Seal, Cab Front Window	042630	1
4	Bolt, 3/8-16 x 3" Hex Head Full Thread	F05007-1	4
5	Washer, 3/8" SAE Flat	F05011-3	4
6	Nut, 3/8-16 Hex Nylon Lock	F05010-10	4

## 12.10 Left Panel

CAB2

Rev. A1.00

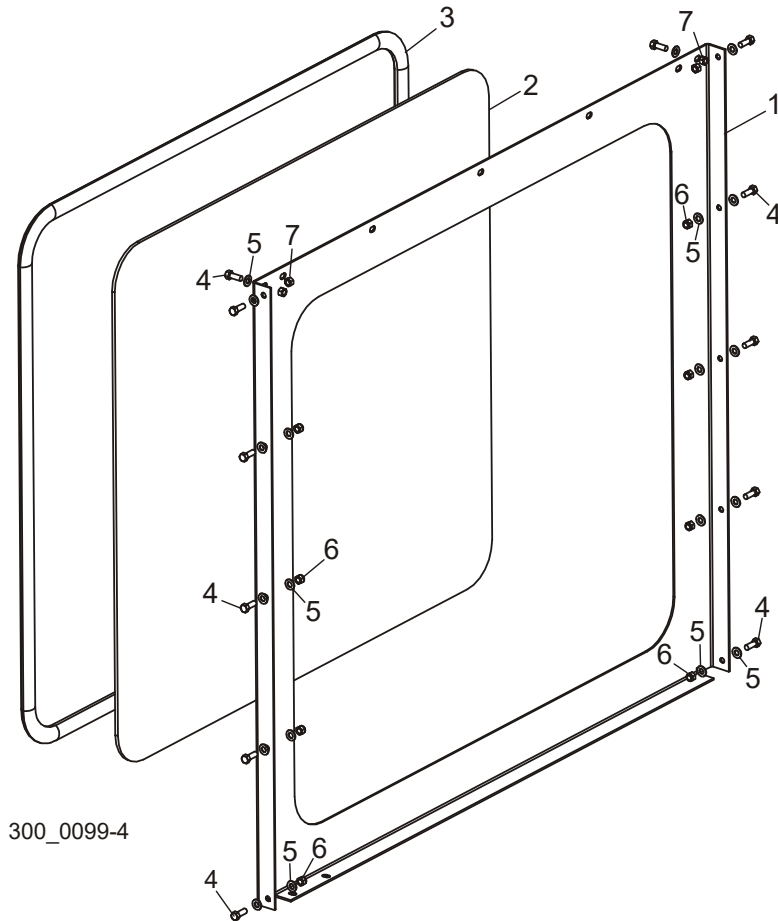

REF	DESCRIPTION (◆ Indicates Parts Available In Assemblies Only)	PART #	QTY.
	<b>PANEL ASSEMBLY, CAB2 LEFT</b>	036588	1
1	Panel, Cab2 Left	036587	1
2	Window, Cab Left	042574	1
3	Seal, Cab Side Window	042573	1
4	<b>BOLT, 3/8-16 X 1" HEX HEAD</b>	F05007-7	12
5	<b>WASHER, 3/8" SAE FLAT</b>	F05011-3	20
6	<b>NUT, 3/8-16 HEX NYLON LOCK</b>	F05010-10	8
7	<b>NUT, 3/8-16 HEX LOCK</b>	F05010-25	4

## 12.11 Left Panel

CAB1

Rev. A1.00

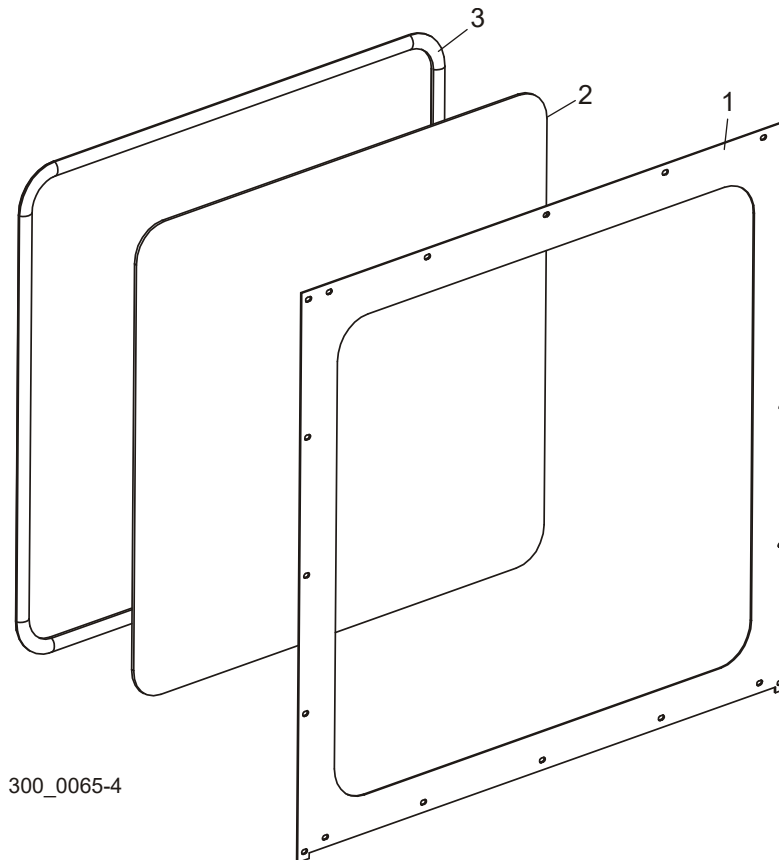

REF	DESCRIPTION (◆ Indicates Parts Available In Assemblies Only)	PART #	QTY.
	<b>PANEL ASSEMBLY, CAB LEFT</b>	042603	1
1	Panel, Cab Left	042616	1
2	Window, Cab Left	042574	1
3	Seal, Cab Side Window	042573	1

**12.12Roof**

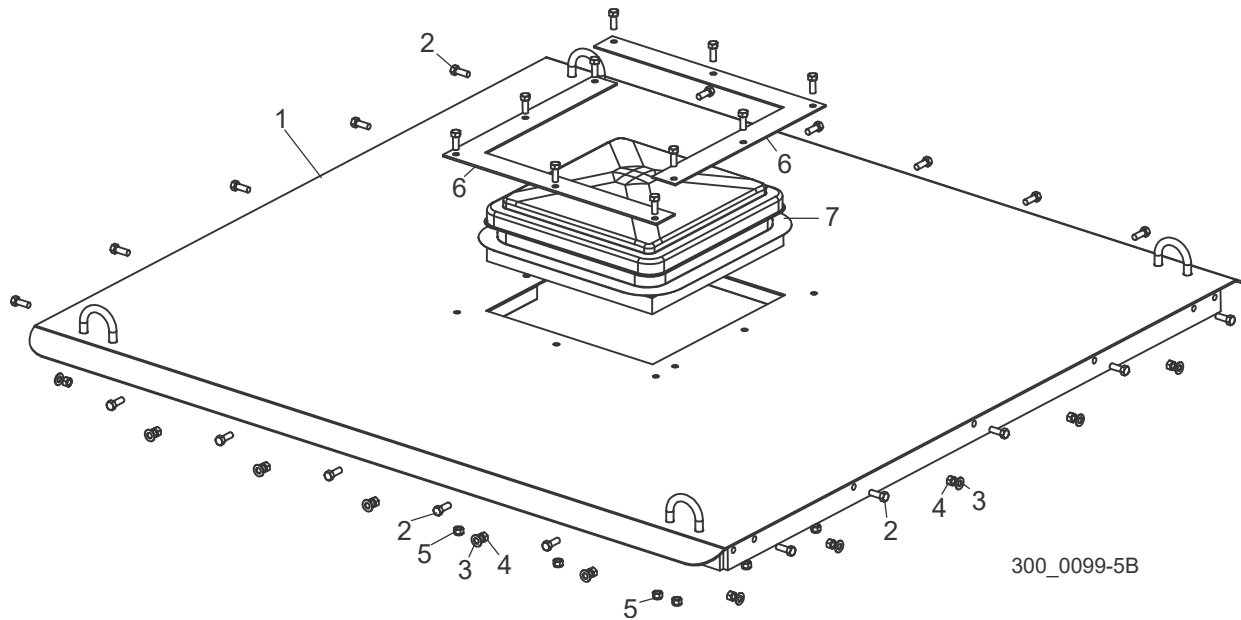

REF	DESCRIPTION (◆ Indicates Parts Available In Assemblies Only)	PART #	QTY.
	<b>ROOF ASSEMBLY, CAB</b>	042635 <sup>1</sup>	1
1	Roof Weldment, Cab	042623 <sup>2</sup>	1
2	Bolt, 3/8-16 x 1" Hex Head	F05007-7	30
3	Washer, 3/8" SAE Flat	F05011-3	20
4	Nut, 3/8-16 Hex Lock	F05010-25	20
5	Nut, 3/8-16 Hex Nylon Lock	F05010-10	10
6	Plate, Vent Mount	016866	2
7	Vent, Plastic Dome	016867	1

<sup>1</sup> Assembly BOM corrected 11/03. Added Flat Washers F05011-3 and changed twenty Nylon Lock Nut F05010-10 to Hex Lock Nut F05010-25.

<sup>2</sup> Lifting Hooks added 4/05 for easier shipping/assembly. Added spacers 1/09 to accommodate new AC unit.

## SECTION 13 BED EXTENSION OPTION

### 13.1 Bed Extension Complete (BX6)<sup>1</sup>

LT300-BX6

Rev. B3.02+

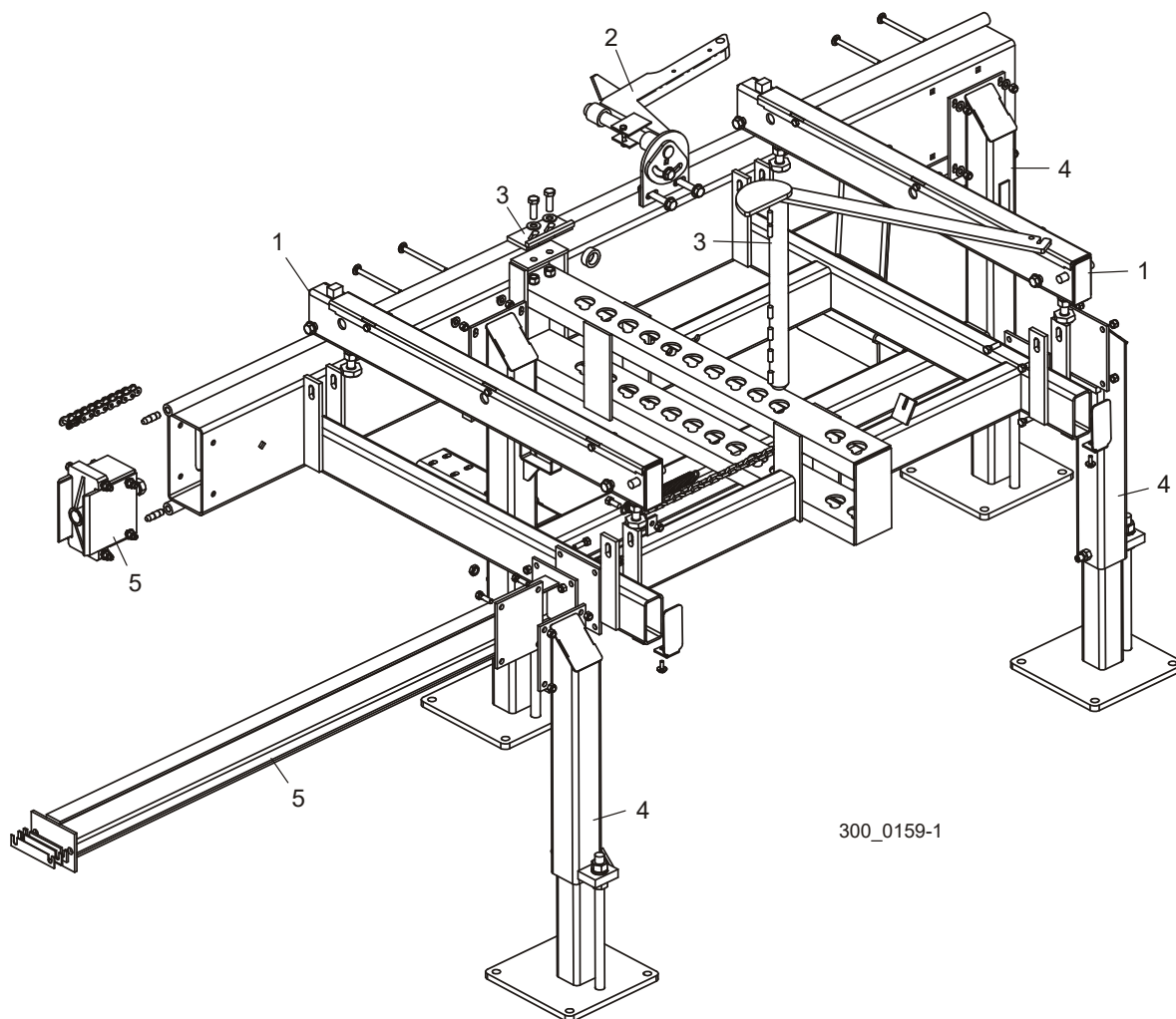

REF	DESCRIPTION (◆ Indicates Parts Available In Assemblies Only)	PART #	QTY.
1	BED RAIL PARTS ( <a href="#">See Section 13.3</a> )		
2	SIDE SUPPORT PARTS ( <a href="#">See Section 13.5</a> )		
3	MANUAL LOG CLAMP PARTS ( <a href="#">See Section 13.6</a> )		
4	LEG PARTS ( <a href="#">See Section 13.8</a> )		
5	CONNECTION PARTS ( <a href="#">See Section 13.9</a> )		

**1. IMPORTANT!** Bed Extension Option can only be purchased with the purchase of a new sawmill and may not be added later.



### 13.2 Bed Extension Complete (BX10)<sup>1</sup>

LT300-BX10

Rev. B4.00+

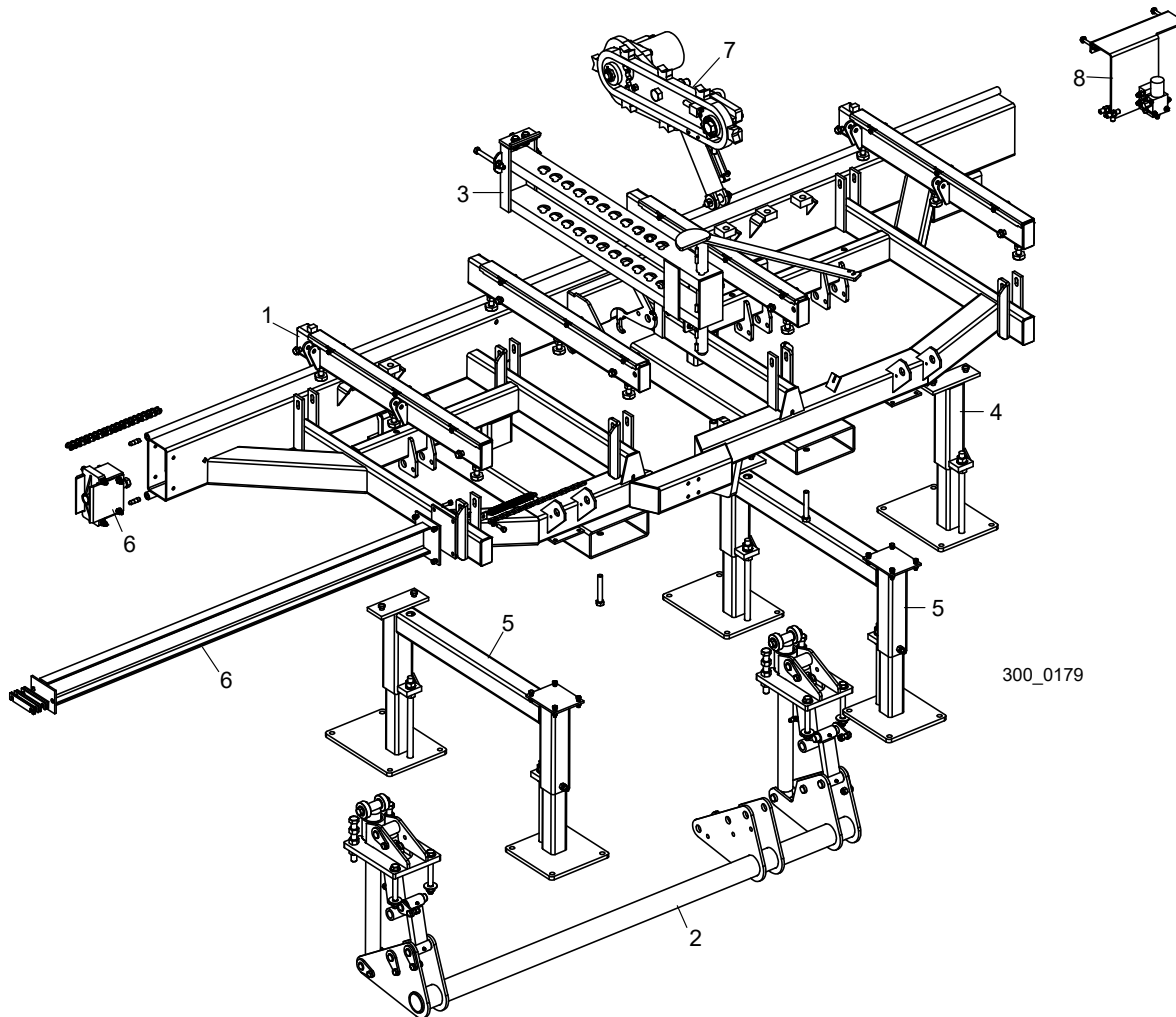

REF	DESCRIPTION (◆ Indicates Parts Available In Assemblies Only)	PART #	QTY.
1	BED RAIL PARTS ( <a href="#">See Section 13.4</a> )		
2	SIDE SUPPORT PARTS ( <a href="#">See Section 8.4</a> )		
3	MANUAL LOG CLAMP PARTS ( <a href="#">See Section 13.7</a> )		
4	REAR LEG PARTS ( <a href="#">See Section 7.9</a> )		
5	FRONT/MIDDLE LEG PARTS ( <a href="#">See Section 7.16</a> )		
6	CONNECTION PARTS ( <a href="#">See Section 13.10</a> )		
7	HYDRAULIC LOG TURNER PARTS ( <a href="#">See Section 8.6</a> )		

**1. IMPORTANT!** Bed Extension Option can only be purchased with the purchase of a new sawmill and may not be added later.

8	HYDRAULIC FLOW CONTROL VALVE PARTS ( <a href="#">See Section 13.11</a> )
---	--

# 13 Bed Extension

## Bed Rails (BX6)

### 13.3 Bed Rails (BX6)

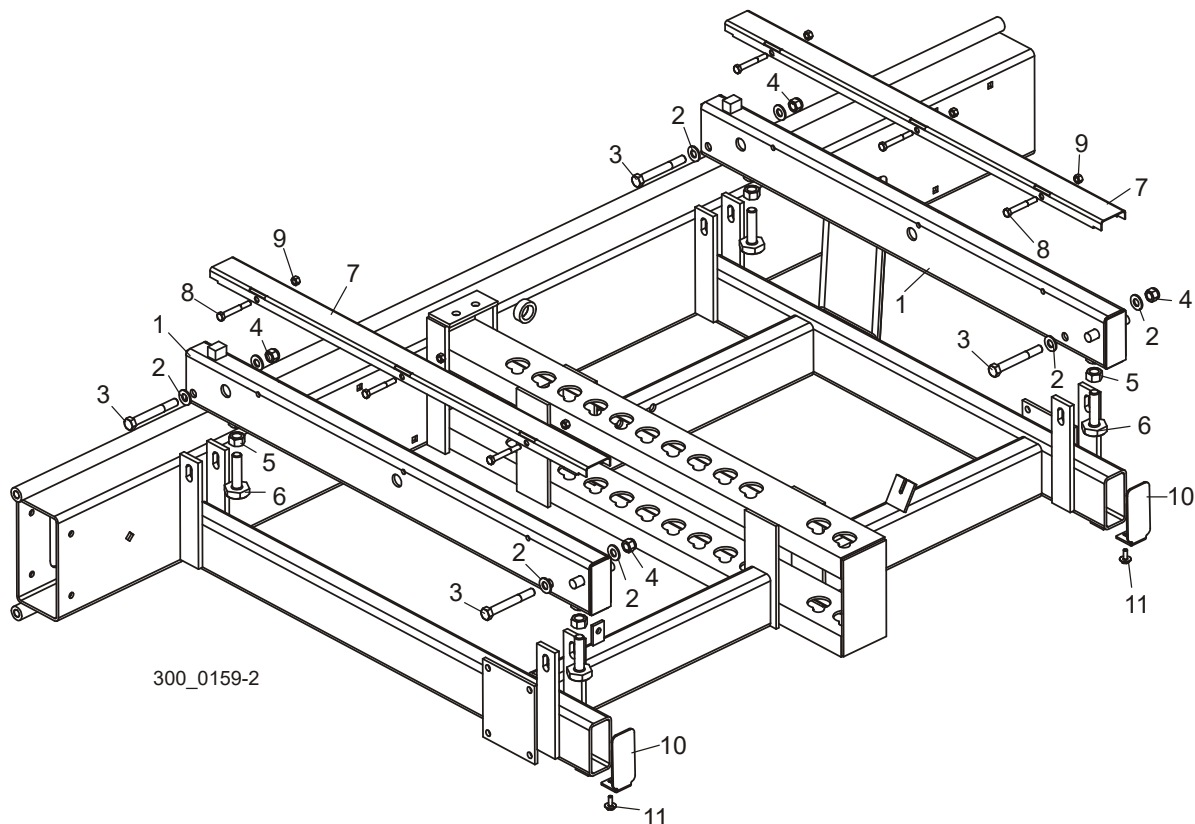

REF	DESCRIPTION (◆ Indicates Parts Available In Assemblies Only)	PART #	QTY.
	<b>RAIL ASSEMBLY, EXTENSION BED</b>	017760	2
1	Tube Weldment, Bed Rail	017759	1
2	Washer, 1/2" SAE Flat	F05011-2	4
3	Bolt, 1/2-13 x 4" Hex Head Grade 5	F05008-78	2
4	Nut, 1/2-13 Hex Nylon Lock	F05010-8	2
5	Nut, 5/8-11 Hex	F05010-5	2
6	Bolt, Bed Rail Adjustment	S13006	2
7	Cover, 36 1/4" Stainless Bed Rail	016898	1
8	Bolt, 5/16-18 x 2 1/2" Hex Head	F05006-10	3
9	Nut, 5/16-18 Hex Lock	F05010-6	3
10	<b>PLATE, 2X4 BED RAIL CAP</b>	038843	2
11	<b>BOLT, 1/4-20 X 3/4" W/CONICAL WASHER HEAD</b>	F05005-134	2

### 13.4 Bed Rails (BX10)

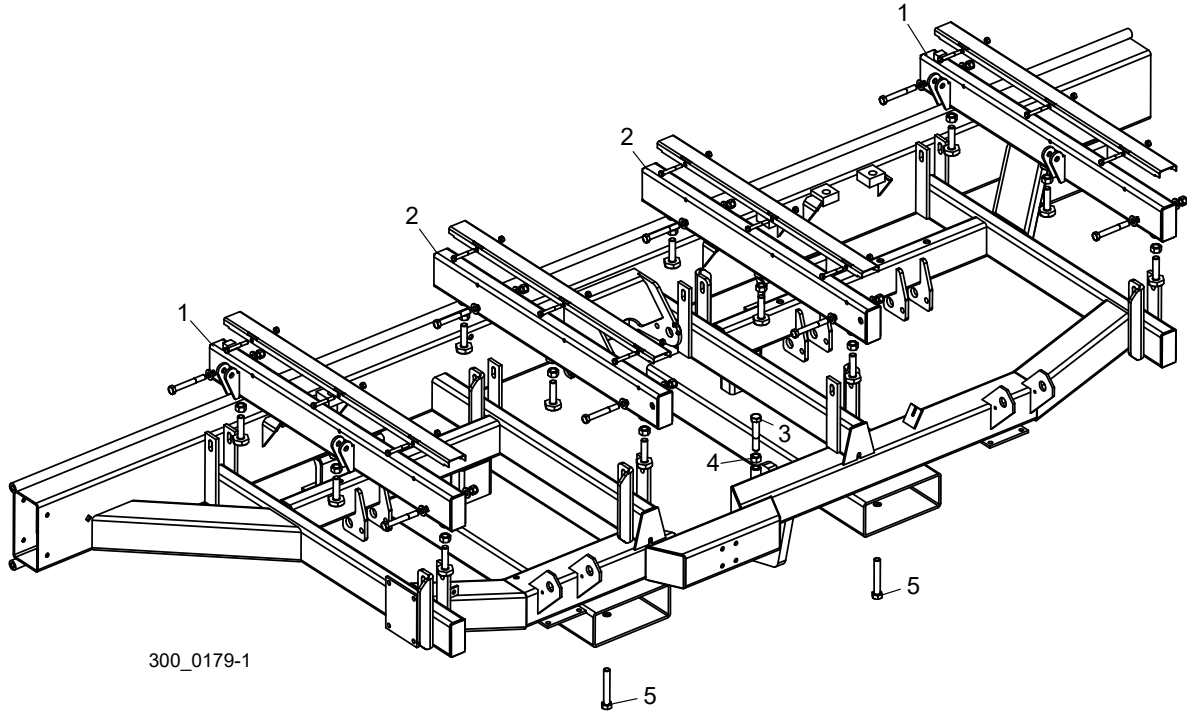

REF	DESCRIPTION (◆ Indicates Parts Available In Assemblies Only)	PART #	QTY.	
1	FRONT/REAR BED RAIL PARTS ( <a href="#">See Section 7.3</a> )			
2	MIDDLE BED RAIL PARTS ( <a href="#">See Section 7.4</a> )			
3	BOLT, 5/8-18 X 3 1/2" HEX HEAD FULL THREAD	F05009-16	1	
4	NUT, 5/8-18 HEX	F05010-50	1	
5	BOLT, 5/8-11 X 4" HEX HEAD FULL THREAD	F05009-8	2	

# 13 Bed Extension

## Side Support (BX6)

### 13.5 Side Support (BX6)

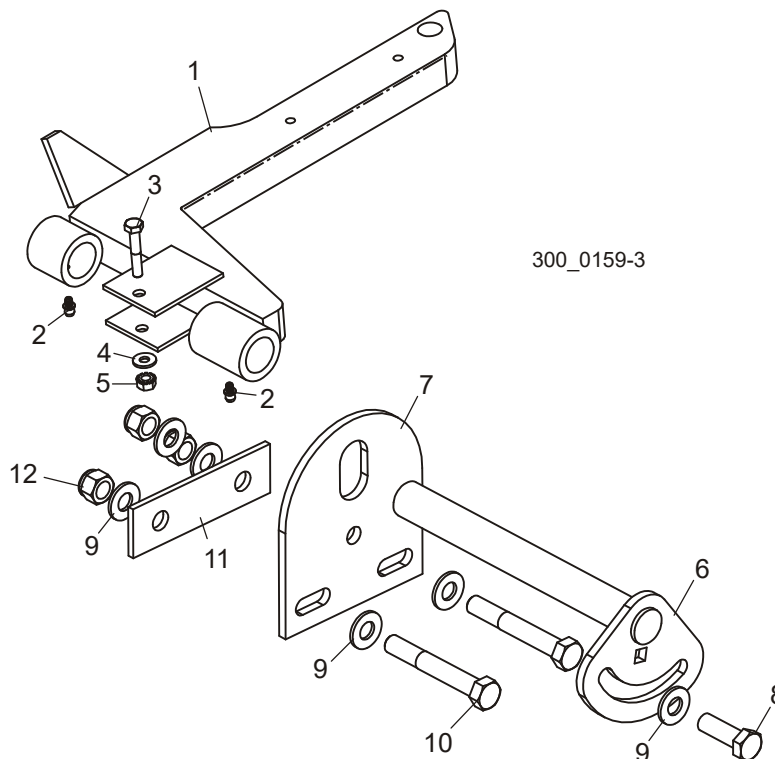

REF	DESCRIPTION (◆ Indicates Parts Available In Assemblies Only)	PART #	QTY.
	<b>SUPPORT ASSEMBLY, MANUAL LOG</b>	034554	1
1	Support Weldment, Manual Log	015235	1
2	Fitting, 3/16" x 3/16" Grease	P04107	2
3	Bolt, 1/4-20 x 1 1/2" Hex Head	F05005-5	1
4	Washer, 1/4" SAE Flat	F05011-11	1
5	Nut, 1/4-20 Self-Locking Hex	F05010-9	1
6	Shaft Weldment, Side Support Mount	016544	1
7	Plate, Side Support Mount	016555	1
8	Bolt, 1/2-13 x 1 1/2" Hex Head Grade 5	F05008-33	1
9	Washer, 1/2" SAE Flat	F05011-2	6
10	Bolt, 1/2-13 x 3 1/2" Hex Head	F05008-15	2
11	Plate, Side Support Clamp	016558	1
12	Nut, 1/2-13 Hex Nylon Lock	F05010-8	3

### 13.6 Manual Clamp (BX6)

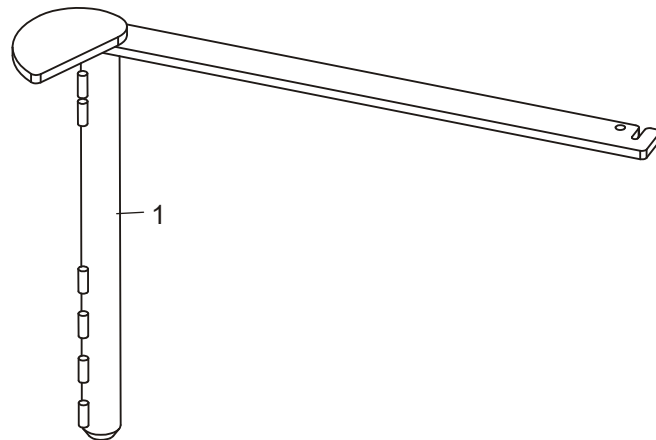
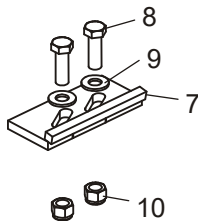

300\_0159-4

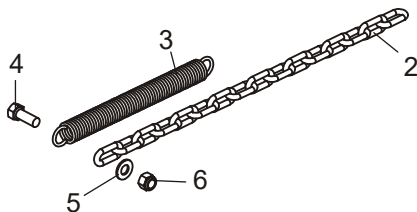

REF	DESCRIPTION (◆ Indicates Parts Available In Assemblies Only)	PART #	QTY.
1	CLAMP WELDMENT, MANUAL LOG	W09412	1
2	CHAIN, 3/16" X 67" ZINC PLATED	M04311	1
3	SPRING, 7/8" X 8 1/2" X 1/8" EXTENSION	P09135	1
4	BOLT, 3/8-16 X 1" HEX HEAD	F05007-7	1
5	WASHER, 3/8" SAE FLAT	F05011-3	1
6	NUT, 3/8-16 HEX NYLON LOCK	F05010-10	1
7	STOP WELDMENT, CLAMP	W09404	1
8	BOLT, 1/2-13 X 1 1/2" HEX HEAD GRADE 5	F05008-33	2
9	WASHER, 1/2" SAE FLAT	F05011-2	2
10	NUT, 1/2-13 HEX NYLON LOCK	F05010-8	2

### 13.7 Manual Clamp (BX10)

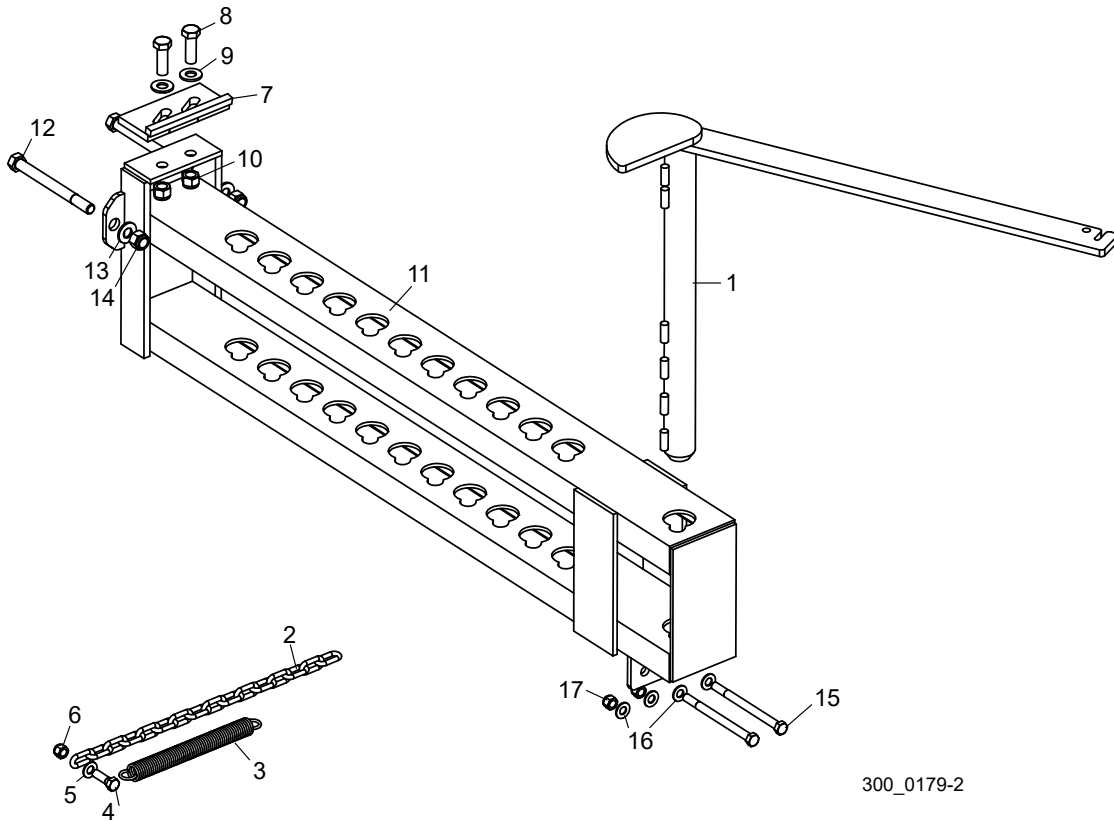

300\_0179-2

REF	DESCRIPTION (◆ Indicates Parts Available In Assemblies Only)	PART #	QTY.
1	CLAMP WELDMENT, MANUAL LOG	W09412	1
2	CHAIN, 3/16" X 67" ZINC PLATED	M04311	1
3	SPRING, 7/8" X 8 1/2" X 1/8" EXTENSION	P09135	1
4	BOLT, 3/8-16 X 1" HEX HEAD	F05007-7	1
5	WASHER, 3/8" SAE FLAT	F05011-3	1
6	NUT, 3/8-16 HEX NYLON LOCK	F05010-10	1
7	STOP WELDMENT, CLAMP	W09404	1
8	BOLT, 1/2-13 X 1 1/2" HEX HEAD GRADE 5	F05008-33	2
9	WASHER, 1/2" SAE FLAT	F05011-2	2
10	NUT, 1/2-13 HEX NYLON LOCK	F05010-8	2
11	CHANNEL WELDMENT, LOG CLAMP BOLT-ON	007122	1
12	BOLT, 1/2-13 X 5 1/2" HEX HEAD GRADE 5	F05008-28	2
13	WASHER, 1/2" SAE FLAT	F05011-2	2
14	NUT, 1/2-13 HEX NYLON LOCK	F05010-8	2
15	BOLT, 3/8-16 X 5" HEX HEAD	F05007-5	2
16	WASHER, 3/8" SAE FLAT	F05011-3	4
17	NUT, 3/8-16 HEX NYLON LOCK	F05010-10	2

13.8 Legs (BX6)

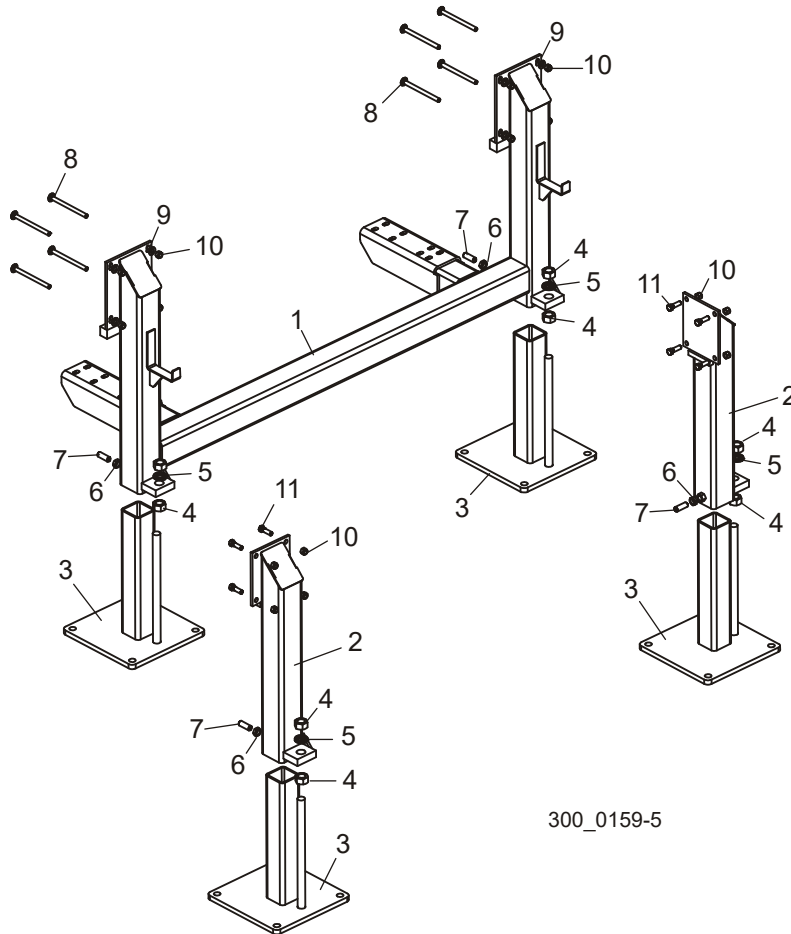

300\_0159-5

REF	DESCRIPTION (◆ Indicates Parts Available In Assemblies Only)	PART #	QTY.
1	LEG WELDMENT, REAR	038757	1
2	LEG WELDMENT, FRONT	038765	2
3	FOOT WLEMDNT, 10" X 10"	051363	4
4	NUT, 3/4-16 HEX	F05010-92	8
5	WASHER, 3/4" SPLIT LOCK	F05011-6	4
6	NUT, 1/2-13 HEX JAM	F05010-31	4
7	SCREW, 1/2-13 SOCKET HEAD FLAP POINT SET	F05008-31	4
8	BOLT, 3/8-16 X 5" CARRIAGE HEAD	F05007-113	8
9	WASHER, 3/8" SAE FLAT	F05011-3	8
10	NUT, 3/8-16 HEX NYLON LOCK	F05010-10	16
11	BOLT, 3/8-16 X 1 1/4" HEX HEAD	F05007-2	8



### 13.9 Connection Hardware (BX6)

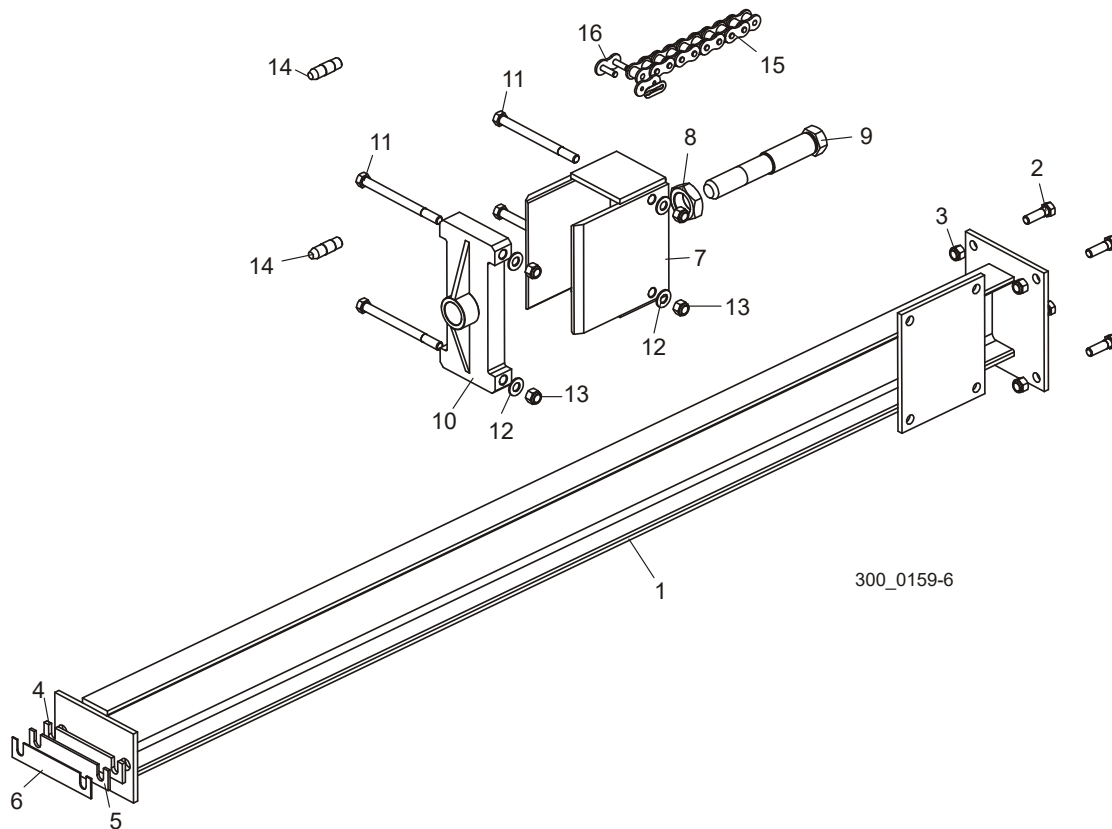

REF	DESCRIPTION (◆ Indicates Parts Available In Assemblies Only)	PART #	QTY.
1	<b>BRACE WELDMENT, BX6</b>	006596	1
2	<b>BOLT, 3/8-16 X 1 1/4" HEX HEAD</b>	F05007-2	4
3	<b>NUT, 3/8-16 HEX NYLON LOCK</b>	F05010-10	4
4	<b>SHIM, 7 GAUGE BEDX</b>	S12025-7	2
5	<b>SHIM, 11 GAUGE BEDX</b>	S12025-11	2
6	<b>SHIM, 16 GAUGE BEDX</b>	S12025-16	2
	<b>BOX ASSEMBLY, BEDX CONNECTION</b>	017700	1
7	Box Weldment, BedX Connection	017695	1
8	Nut, 1-14 Left Hand Hex Jam	F05010-172	1
9	Screw, BedX Connection	017690	1
10	Plate Weldment, BedX Connection	017699	1
11	Bolt, 3/8-16 x 4 3/4" Hex Head Grade 5	F05007-109	4
12	Washer, 3/8" SAE Flat	F05011-13	4
13	Nut, 3/8-16 Hex Nylon Lock	F05010-10	4
14	<b>PIN, BEDX CONNECTING</b>	017689	2
15	<b>CHAIN, #60 X 70 1/2"</b>	017840	1
16	<b>LINK, #60 MASTER</b>	042398	1

### 13.10 Connection Hardware (BX10)

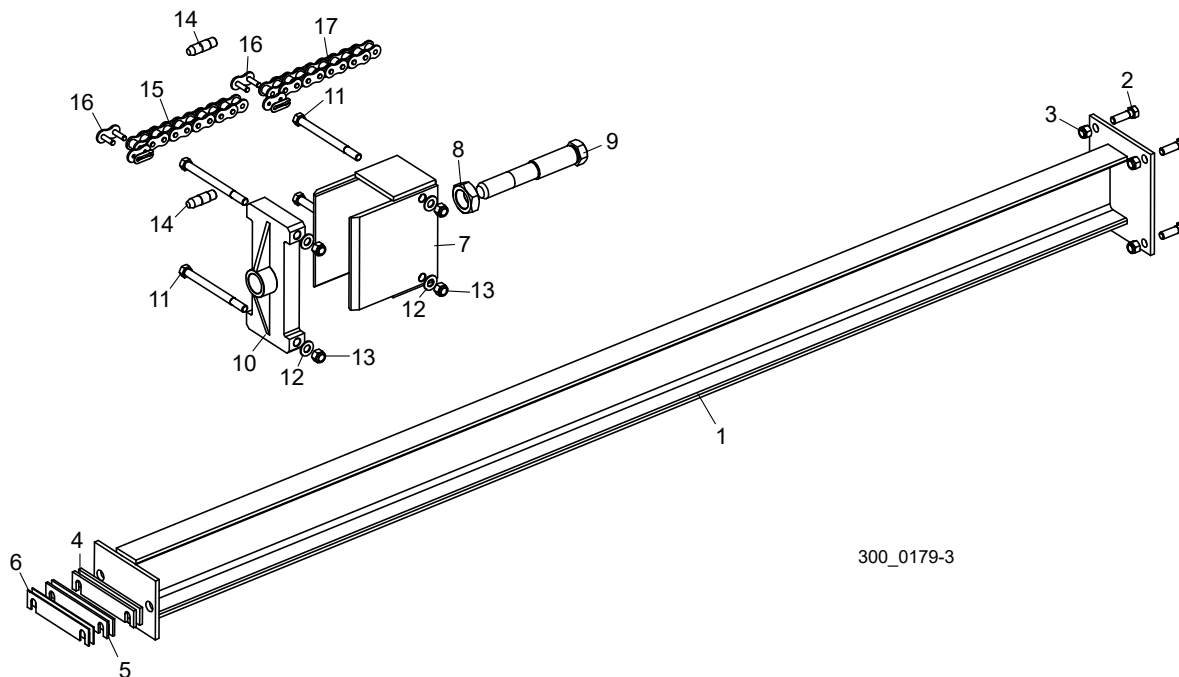

300\_0179-3

REF	DESCRIPTION (◆ Indicates Parts Available In Assemblies Only)	PART #	QTY.
1	<b>BRACE WELDMENT, BX10</b>	007130	1
2	<b>BOLT, 3/8-16 X 1 1/4" HEX HEAD</b>	F05007-2	4
3	<b>NUT, 3/8-16 HEX NYLON LOCK</b>	F05010-10	4
4	<b>SHIM, 7 GAUGE BEDX</b>	S12025-7	2
5	<b>SHIM, 11 GAUGE BEDX</b>	S12025-11	2
6	<b>SHIM, 16 GAUGE BEDX</b>	S12025-16	2
	<b>BOX ASSEMBLY, BEDX CONNECTION</b>	017700	1
7	Box Weldment, BedX Connection	017695	1
8	Nut, 1-14 Left Hand Hex Jam	F05010-172	1
9	Screw, BedX Connection	017690	1
10	Plate Weldment, BedX Connection	017699	1
11	Bolt, 3/8-16 x 4 3/4" Hex Head Grade 5	F05007-109	4
12	Washer, 3/8" SAE Flat	F05011-13	4
13	Nut, 3/8-16 Hex Nylon Lock	F05010-10	4
14	<b>PIN, BEDX CONNECTING</b>	017689	2
15	<b>CHAIN, #60 X 70 1/2"</b>	017840	1
16	<b>LINK, #60 MASTER</b>	042398	2
17	<b>CHAIN, #60 X 49 1/2"</b>	017641	1

# 13

## Bed Extension Hydraulic Flow Control Valve (BX10)

### 13.11 Hydraulic Flow Control Valve (BX10)

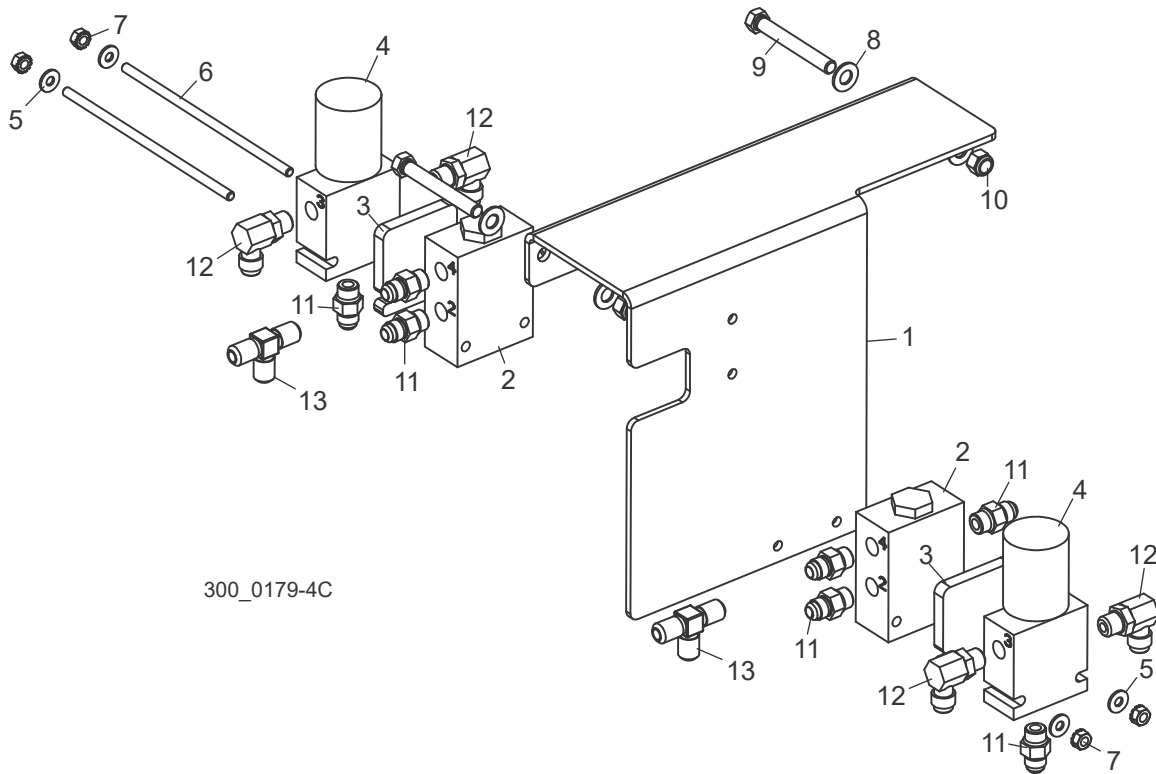

REF	DESCRIPTION (◆ Indicates Parts Available In Assemblies Only)	PART #	QTY.
	<b>VALVE ASSEMBLY, HYDRAULIC BX10 FLOW CONTROL</b>	007501	1
1	Plate, Flow Divider Valve Mount	007272	1
2	Valve, Hydraulic Flow Divider	007588 <sup>1</sup>	2
3	Plate, Flow Divider Valve Spacer	007271	2
4	Valve, 24VDC Hydraulic Flow Diverter	007589	2
5	Washer, 1/4" SAE Flat	F05011-11	4
6	Screw, 1/4-20 x 6 1/2" Socket Head	008950 <sup>1</sup>	2
7	Nut, 1/4-20 Hex Nylon Lock	F05010-9 <sup>1</sup>	4
8	Washer, 3/8" SAE Flat	F05011-3	4
9	Bolt, 3/8-16 x 3" Hex Head Full Thread	F05007-1	2
10	Nut, 3/8-16 Hex Nylon Lock	F05010-10	2
11	Fitting, 3/8" O-Ring x 3/8" JIC	014687	8
12	Fitting, #6 SAE x 3/8" JIC Elbow	P12704	4
13	Fitting, 3/8" JIC Tee	015487	2

<sup>1</sup> Flow Divider 007588 changed by vendor 3/10. New valve requires two new Threaded Studs 008950, Flat Washers F05011-11 and four Self-Locking Hex Nuts F05010-9 (replaces 1/4-20 x 6 1/2" Hex Bolt F05005-182 and Lock Nuts F05010-69).

# INDEX

## B

- bed extension
  - bed rails (BX10) 13-5
  - bed rails (BX6) 13-4
  - complete BX10 13-2
  - complete BX6 13-1
  - connection hardware (BX10) 13-11
  - connection hardware (BX6) 13-10
  - hydraulic flow control (BX10) 13-12
  - legs (BX6) 13-9
  - manual clamp (BX10) 13-8
  - manual clamp (BX6) 13-7
  - side support (BX6) 13-6
- bed frame
  - bed rail (middle) 7-4, 7-5
  - bed rail #1 7-1, 7-2
  - bed rail #2 7-3
  - bed rail #4 7-6
  - bed rail #5 7-7, 7-8
  - cable carrier 7-29, 7-30, 7-31
  - leg (#1 & #2) 7-14
  - leg (#2 & #5) 7-16, 7-17
  - leg (#3 & #4) 7-18, 7-19, 7-20
  - leg (front & rear) 7-10, 7-11, 7-12, 7-13
  - wireway 7-22, 7-25, 7-27
  - wireway (LT300-BX6) 7-23
- blade guide arm 2-25
- blade guides
  - block kit 2-2
  - drive side assembly 2-14, 2-17, 2-20, 2-23
  - idle side assembly 2-3, 2-6, 2-9, 2-12
  - idle side roller 2-1, 2-2
  - roller/block kit 2-1
- blade wheels
  - brake actuator & strap 3-9
  - drive side 3-5, 3-7
  - idle side w/brake 3-4

## C

- cab option 12-1, 12-2
  - frame 12-3
  - front panel 12-13, 12-14
  - left panel 12-15, 12-16
  - rear panel 12-5, 12-7
  - right panel 12-9, 12-11
  - roof 12-17

## D

- drive assembly
  - blade motor 3-11, 3-13, 3-15
- drive shaft 3-1, 3-2, 3-3

## E

- electrical harnesses & cables 9-7, 9-9, 9-10

## H

- hydraulics
  - hoses 8-40, 8-42, 8-43
  - log clamp 8-16
  - log loader 8-1, 8-3, 8-5
  - log turner 8-10, 8-12, 8-14
  - pump & tank 8-21, 8-23
  - pump/valve/tank 8-25
  - side support (middle) 8-8
  - side supports 8-6
  - taper set roller 8-37
  - taper set roller valve 8-39
  - toe board (front) 8-18
  - toe board (rear w/ramp) 8-20
  - toe board (rear) 8-19
  - valve 8-28, 8-30, 8-32, 8-34

## L

- lube system 9-1, 9-3

lube system (optional pressure) 11-1

---

## M

manuals 9-6

---

## O

operator station

air supply 10-11, 10-13

frame/rails/ladder 10-1, 10-3, 10-5

seat/joystick controls 10-7, 10-9

---

## P

pantograph 9-11

parts list

how to use 1-1

power feed

drive 6-9

feed chain/stops 6-13, 6-14, 6-16

lower track rollers 6-3, 6-5, 6-7

lower wireway 6-18, 6-19, 6-20, 6-22, 6-24, 6-26

track oiler 6-11

upper track rollers 6-1

---

## S

saw head

blow-off assembly 4-14, 4-15

board return 4-1, 4-2, 4-3

board return guide 4-4, 4-5

covers 4-6, 4-8, 4-10, 4-12

decals 4-18, 4-19

head/air box 4-20

laser assembly 4-16

---

## T

tools 9-5

---

## U

up/down

ballscrew mount (middle) 5-12, 5-14

ballscrew mount (top) 5-15, 5-16

bearing rails 5-3

drive 5-4, 5-6, 5-8, 5-10

head stop 5-17, 5-19, 5-21, 5-23

mast pads/rollers 5-1

transducer 5-17, 5-19, 5-21, 5-23

---

## V

vacuum system (optional) 9-13

vacuum system cable carrier (optional) 9-15