

Parts Manual

WM3500 & WM3500-BX6

rev. B8.01



Safety is our #1 concern! Read and understand all safety information and instructions before operating, setting up or maintaining this machine.

Form #1637

California
Proposition 65 Warning



WARNING: Breathing gas/diesel engine exhaust exposes you to chemicals known to the State of California to cause cancer and birth defects or other reproductive harm.

Always start and operate the engine in a well-ventilated area.
If in an enclosed area, vent the exhaust to the outside.
Do not modify or tamper with the exhaust system.
Do not idle the engine except as necessary.

For more information go to **www.P65warnings.ca.gov**.



WARNING: Drilling, sawing, sanding or machining wood products can expose you to wood dust, a substance known to the State of California to cause cancer. Avoid inhaling wood dust or use a dust mask or other safeguards for personal protection.

For more information go to **www.P65Warnings.ca.gov/wood**.

©2019

Printed in the United States of America, all rights reserved. No part of this manual may be reproduced in any form by any photographic, electronic, mechanical or other means or used in any information storage and retrieval system without written permission from

Wood-Mizer
8180 West 10th Street
Indianapolis, Indiana 46214

Table of Contents

Section-Page

SECTION 1	GENERAL INFORMATION	1-1
1.1	How To Use The Parts List	1-1
1.2	Sample Assembly	1-1
SECTION 2	BLADE GUIDES & ARM	2-1
2.1	Blade Guides (Roller/Block, Standard).....	2-1
2.2	Blade Guide Kit (Block, Optional).....	2-2
2.3	Blade Guide Assembly, Idle Side (Roller/Block, Standard)	2-3
2.4	Blade Guide Assembly, Idle Side (Block, Optional)	2-5
2.5	Blade Guide Assembly, Drive Side (Roller/Block, Standard)	2-7
2.6	Blade Guide Assembly, Drive Side (Block, Optional).....	2-9
2.7	Blade Guide Arm.....	2-11
SECTION 3	BLADE WHEELS & TENSIONER	3-1
3.1	Drive Shaft Assembly.....	3-1
3.2	Idle Shaft/Brake Drum	3-2
3.3	Blade Wheel Kit, Belted (Standard).....	3-3
3.4	Blade Wheel Kit, Crowned (Optional).....	3-5
3.5	Brake Assembly.....	3-7
SECTION 4	SAW HEAD	4-1
4.1	Board Return	4-1
4.2	Board Return Guide.....	4-2
4.3	Covers & Sawdust Chute.....	4-3
4.4	Blow-Off Assembly.....	4-5
4.5	Laser Assembly	4-6
4.6	Decals	4-8
4.7	Head/Air Box Control Assembly	4-9
4.8	Blade Motor Drive Assembly.....	4-12
SECTION 5	UP/DOWN SYSTEM	5-1
5.1	Mast Pads & Rollers	5-1
5.2	Bearing Rails	5-3
5.3	Up/Down Ballscrew Drive	5-4
5.4	Ballscrew Mount (Middle)	5-6
5.5	Ballscrew Mount (Top)	5-8
5.6	Transducer & Head Stop	5-9
5.7	Up/Down Energy Chain Assembly	5-11

Table of Contents

Section-Page

SECTION 6	POWER FEED	6-1
6.1	Upper Track Rollers	6-1
6.2	Lower Track Rollers.....	6-3
6.3	Power Feed Drive	6-5
6.4	Feed Chain & Stops.....	6-7
6.5	Lower Wireway	6-8
SECTION 7	BED FRAME	7-1
7.1	Bed Rail #1 (Front).....	7-1
7.2	Bed Rail #2 (Middle Front).....	7-2
7.3	Bed Rail (Middle).....	7-3
7.4	Bed Rail #4 (Middle Rear).....	7-4
7.5	Bed Rail #5 (Rear).....	7-5
7.6	Leg Assembly (Front & Rear).....	7-6
	<i>WM3500 (with Pantograph Cable Boom)</i>	
7.7	Leg Assembly (Front & Rear).....	7-7
	<i>WM3500 (without Pantograph Cable Boom)</i>	
7.8	Leg Assembly (#2 & #5).....	7-8
	<i>WM3500 (with Pantograph Cable Boom)</i>	
7.9	Leg Assembly (#2 & #5).....	7-9
	<i>WM3500 (without Pantograph Cable Boom)</i>	
7.10	Leg Assembly (#3 & #4).....	7-10
	<i>WM3500 (with Pantograph Cable Boom)</i>	
7.11	Leg Assembly (#3 & #4).....	7-11
	<i>WM3500 (without Pantograph Cable Boom)</i>	
7.12	Wireway	7-12
	<i>WM3500 (without Pantograph Cable Boom)</i>	
7.13	Cable Carrier	7-13
	<i>WM3500 (without Pantograph Cable Boom)</i>	
SECTION 8	HYDRAULICS	8-1
8.1	Hydraulic Log Loader Option	8-1
8.2	Hydraulic Side Supports.....	8-3
8.3	Side Support (Middle).....	8-5
8.4	Hydraulic Log Turner.....	8-7
8.5	Hydraulic Log Clamp	8-9
8.6	Hydraulic Toe Board (Front).....	8-11
8.7	Hydraulic Toe Board (Rear).....	8-12
8.8	Hydraulic Pump & Tank	8-13
8.9	Hydraulic Toe Board (Rear w/Ramp)	8-15
8.10	Hydraulic Valve.....	8-16
8.11	Hydraulic Turner Sequence Valve	8-18
8.12	Power Taper Set Roller (Optional).....	8-19
8.13	Valve Assembly, Power Taper Set Roller (Optional)	8-21
8.14	Hydraulic Hoses	8-22

Table of Contents

Section-Page

SECTION 9	MISCELLENEOUS	9-1
9.1	Lube System	9-1
9.2	Tools	9-3
9.3	Manuals	9-4
9.4	Electrical Harnesses/Cables.....	9-5
9.5	Pantograph Assembly.....	9-7
SECTION 10	OPERATOR STATION	10-1
10.1	Frame, Rails & Ladder	10-1
10.2	Seat & Joystick Controls	10-3
10.3	Electrical Box Assembly	10-5
10.4	Air Supply	10-7
SECTION 11	PRESSURE LUBE OPTION	11-1
11.1	Pressure Lube System.....	11-1
SECTION 12	CAB OPTION	12-1
12.1	Cab.....	12-1
12.2	Rear Panel.....	12-2
12.3	Right Panel	12-4
12.4	Front Panel.....	12-6
12.5	Left Panel.....	12-7
12.6	Roof.....	12-8
SECTION 13	BED EXTENSION OPTION	13-1
13.1	Bed Extension Complete (BX6).....	13-1
13.2	Bed Rails (BX6)	13-2
13.3	Manual Clamp (BX6).....	13-3
13.4	Connection Hardware (BX6).....	13-4
13.5	Hydraulic Flow Control Valve (BX10).....	13-5
	INDEX	I

SECTION 1 GENERAL INFORMATION

1.1 How To Use The Parts List

- Use the table of contents or index to locate the assembly that contains the part you need.
- Go to the appropriate section and locate the part in the illustration.
- Use the number pointing to the part to locate the correct part number and description in the table.
- Parts shown indented under another part are included with that part.
- Parts marked with a diamond (◆) are only available in the assembly listed above the part.

See the sample table below. Sample Part #A01111 includes part F02222-2 and subassembly A03333. Subassembly A03333 includes part S04444-4 and subassembly K05555. The diamond (◆) indicates that S04444-4 is not available except in subassembly A03333. Subassembly K05555 includes parts M06666 and F07777-77. The diamond (◆) indicates M06666 is not available except in subassembly K05555.

1.2 Sample Assembly				
REF	DESCRIPTION (◆ Indicates Parts Available In Assemblies Only)	PART #	QTY.	
	SAMPLE ASSEMBLY, COMPLETE (INCLUDES ALL INDENTED PARTS BELOW)	A01111	1	
1	Sample Part	F02222-22	1	
	Sample Subassembly (Includes All Indented Parts Below)	A03333	1	
2	Sample Part (◆ Indicates Part Is Only Available With A03333)	S04444-4	1	◆
	Sample Subassembly (Includes All Indented Parts Below)	K05555	1	
3	Sample Part (◆ Indicates Part Is Only Available With K05555)	M06666	2	◆
4	Sample Part	F07777-77	1	

To Order Parts:

- From the continental U.S., call **1-800-525-8100** to order parts. Have your customer number, vehicle identification number, and part numbers ready when you call.
- From other international locations, contact the Wood-Mizer distributor in your area for parts.

SECTION 2 BLADE GUIDES & ARM

2.1 Blade Guides (Roller/Block, Standard)

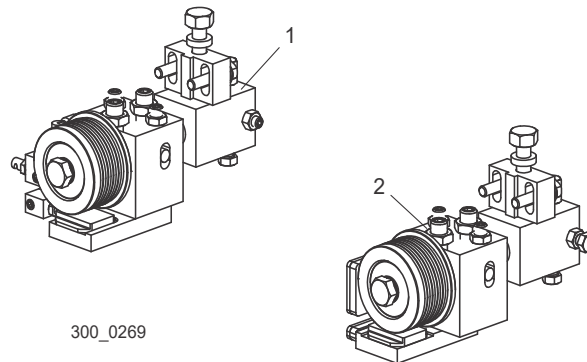

REF	DESCRIPTION (◆ Indicates Parts Available In Assemblies Only)	PART #	QTY.
1	INDUSTRIAL MILL IDLE SIDE BLADE GUIDE PARTS (See Section 2.3)		
2	INDUSTRIAL MILL DRIVE SIDE BLADE GUIDE PARTS (See Section 2.5)		

2 **Blade Guides & Arm**
Blade Guide Kit (Block, Optional)

2.2 Blade Guide Kit (Block, Optional)

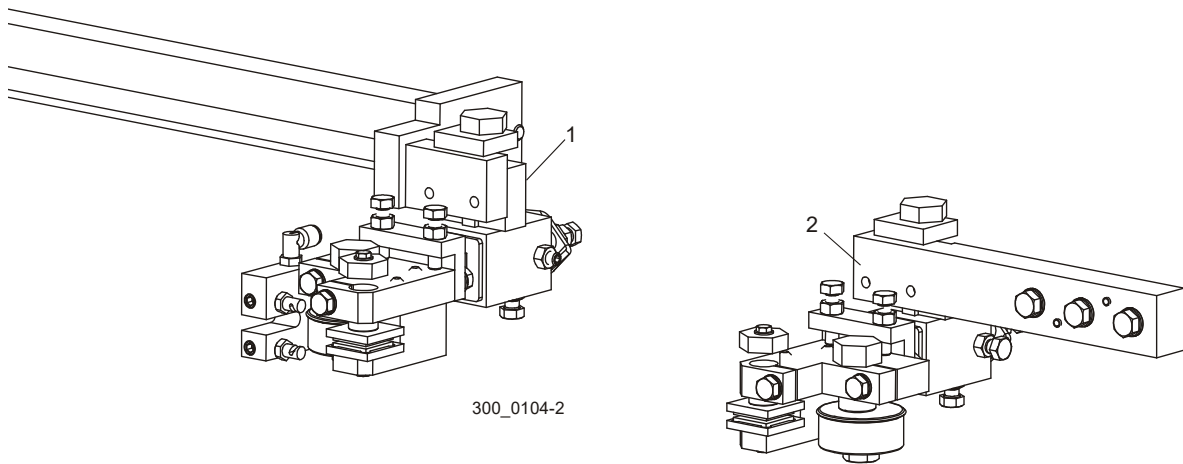

REF	DESCRIPTION (◆ Indicates Parts Available In Assemblies Only)	PART #	QTY.
	GUIDE KIT, BLOCK BLADE		
1	Idle Side Blade Guide Parts (See Section 2.4)		
2	Drive Side Blade Guide Parts (See Section 2.6)		

2.3 Blade Guide Assembly, Idle Side (Roller/Block, Standard)

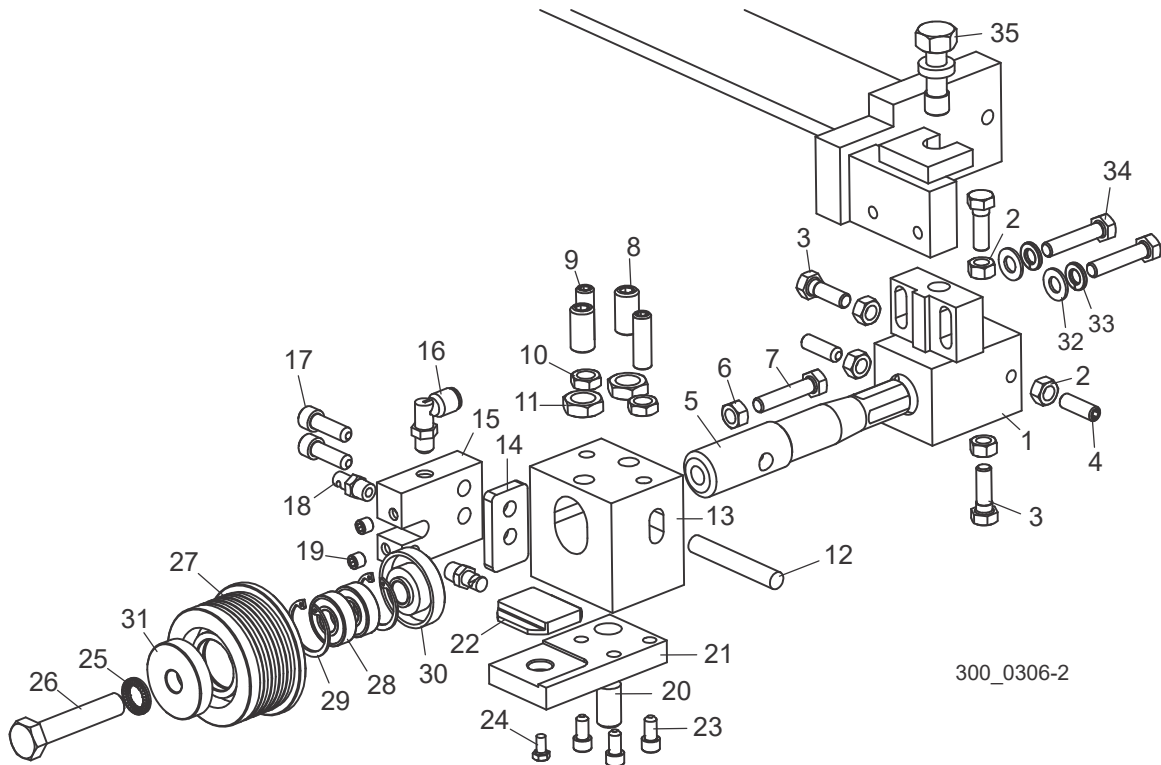

REF	DESCRIPTION (◆ Indicates Parts Available In Assemblies Only)	PART #	QTY.
	ROLLER/BLOCK ASSEMBLY, INDUSTRIAL MILL IDLE SIDE (OUTER)	071355	1
	Block Assembly, Industrial Mill Idle Blade Guide Mount	074095	1
1	Block Weldment, Industrial Mill Blade Guide Mount	062789	1
2	Nut, 5/16-18 Hex	F05010-17	5
3	Bolt, 5/16-18 x 1" Hex Head Stainless Steel	F05006-88	3
4	Screw, 5/16-18 x 1" Socket Head Flat Point Stainless Steel Set	F05006-122	2
5	Shaft, Blade Guide Roller Mount	062777	1
6	Nut, 5/16-18 Hex	F05010-17	1
7	Bolt, 5/16-18 x 1 1/2" Hex Head Full Thread Grade 5	F05006-76	1
8	Screw, 1/2-13 x 1" SS Set	F05008-186	3
9	Screw, 3/8-16 x 1 1/4" SS Set	F05007-239	2
10	Nut, 3/8-16 Jam	F05010-29	2
11	Nut, 1/2-13 Jam	F05010-31	2
12	Pin, 3/8" x 2 1-2" Harden Dowel	F05012-143	1
13	Block, Wear Pad Adjustment	062778	1
14	Block, Nozzle Spacer	062785	1
15	Block, Waterlube	062781	1

2

Blade Guides & Arm

Blade Guide Assembly, Idle Side (Roller/Block, Standard)

16	Fitting, 1/8" MPT x 1/4" Tube Swivel Elbow	P09736	1	
17	Bolt, 5/16-18 x 1" SHC	F05006-19	2	
18	Fitting, Blade Lube Spray Nozzle	033479	2	
19	Plug, 1/16" NPT	007734	2	
20	Screw, 1/2-13 x 1" SS Set	F05008-186	3	
21	Bloc, Idle Side Pad Holder	071064	1	
22	Wear Pad, 1.5 Blade Guide	052309	1	
23	Screw, 1/4-20 x 1/2" SHC	F05005-39	3	
24	Bolt, #10-32 x 3/8" HH SS	F05004-171	1	
25	Washer, 1/2" Nord-Lock	F05011-125	1	
26	Bolt, M12-1.75 x 60 HH CL10.9	F05023-8	1	
	Roller, TVS Blade Guide	500561	1	
27	Roller, TVS Blade Guide Wide	500560	1	
28	Bearing, 6001 2RSR	087893	2	
29	Ring, W28 Inside Retaining	F81090-9	2	
30	Ring, Zinc-Plated Spacer (For Ext. Roll)	087892-1	1	
31	Ring, Zinc-Plated Spacer (For Ext. Roll)	087891-1	1	
32	Washer, 5/16" SAE Flat	F05011-17	2	
33	Washer, 5/16" Split Lock	F05011-13	2	
34	Bolt, 5/16-18 x 1 1/2" Hex Head Full Thread Grade 5	F05006-76	2	
35	Bolt, Blade Guide Vertical Adjustment	035656	1	

2.4 Blade Guide Assembly, Idle Side (Block, Optional)

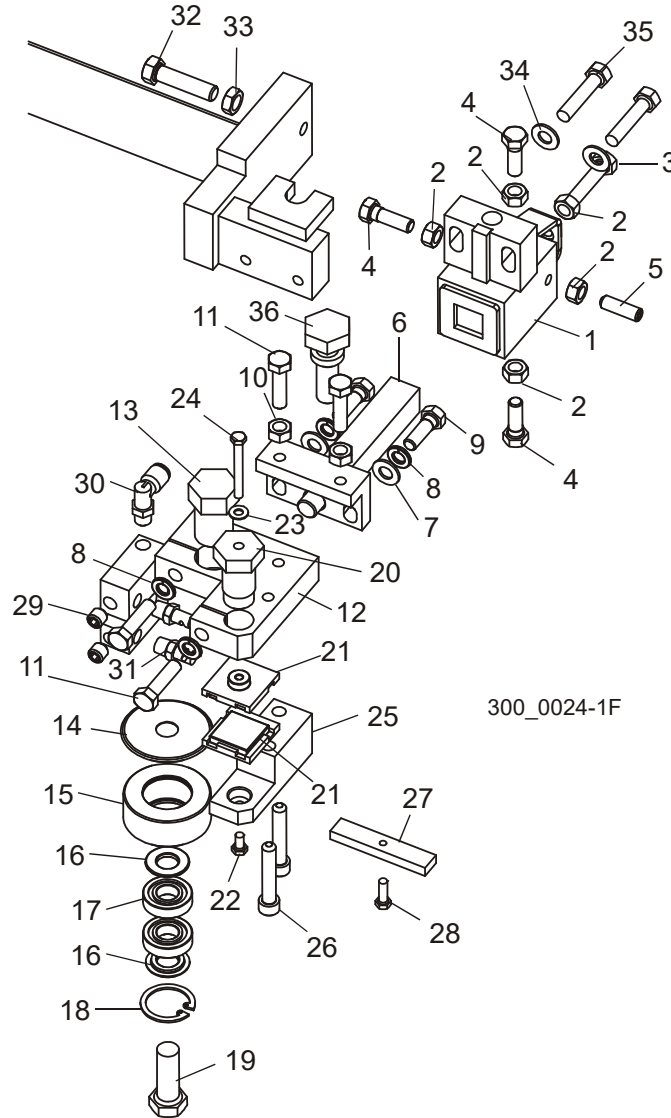

REF	DESCRIPTION (◆ Indicates Parts Available In Assemblies Only)	PART #	QTY.
	GUIDE ASSEMBLY, IDLE SIDE BLOCK/ROLLER	035200	1
	Block Assembly, Idle Side Blade Guide	036099	1
1	Block Weldment, Blade Guide Mount	035219	1 ◆
2	Nut, 5/16-18 Hex	F05010-17	5
3	Bolt, 5/16-18 x 1 1/2" Hex Head Full Thread Stainless Steel	F05006-119	1
4	Bolt, 5/16-18 x 1" Hex Head Stainless Steel	F05006-88	3
5	Screw, 5/16-18 x 1" Socket Head Flat Point Stainless Steel	F05006-122	1
6	Shaft Weldment, Block Guide Pivot	035209	1
7	Washer, 5/16" SAE Flat	F05011-17	2

2

Blade Guides & Arm

Blade Guide Assembly, Idle Side (Block, Optional)

8	Washer, 5/16" Split Lock	F05011-13	4	
9	Bolt, 5/16-18 x 1" Hex Head Stainless Steel	F05006-88	2	
10	Nut, 5/16-18 Hex	F05010-17	2	
11	Bolt, 5/16-18 x 1 1/4" Hex Head Stainless Steel	F05006-118	4	
12	Block Weldment, Upper Blade Guide	035206	1	
13	Bolt, Blade Guide Roller Mount	035215	1	
14	Hood, Blade Guide Back Roller	042848	1	
	Roller Assembly, Blade Guide	023977	1	
15	Housing, Blade Guide Roller	017223	1	◆
16	Spacer, Blade Guide Roller	018948	2	
17	Bearing, R8-2RS Blade Guide	015975	2	
18	Ring, 1 1/8" IR 3000x112 Retaining	F04254-1	1	
19	Bolt, 1/2-13 x 1 1/2" Hex Head	F05008-4	1	
20	Bolt, Blade Guide Block Mount	035216	1	
21	Block, Blade Guide Wear (Standard for 1 1/2" or 1 3/4" Blades)	052309 ¹	2	
	Block, Blade Guide Wear (Optional for 1 1/4" Blades)	052355 ¹	2	
	Disk Assembly, 1" Sq. EZ-Glide Wear	036347 ¹	2	
22	Bolt, #10-32x1/2 HH	F05004-60 ²	1	
	Screw, #10-32 x 3/8" Hex Head Stainless Steel	F05004-171	1	
23	Washer, #10 Brass	042867	1	
24	Bolt, #10-32 x 1 3/4" Hex Head Stainless Steel	F05004-178	1	
25	Block, Lower Blade Guide	035213	1	
26	Screw, 5/16-18 x 1 3/4" Socket Head	F05006-65	2	
27	Block, Blade Guide Alignment	035799	1	
28	Screw, #10-32 x 5/8" Hex Head	F05004-152	1	
29	Fitting, 1/8" NPT Socket Pipe Plug	P30127	2	
30	Fitting, 1/8" MPT x 1/4" Tube Swivel Elbow	P09736	1	
31	Fitting, Blade Lube Spray Nozzle	033479	2	
32	BOLT, 3/8-16 X 1 1/2" HEX HEAD FULL THREAD	F05007-17	1	
33	NUT, 3/8-16 HEX JAM	F05010-29	1	
34	WASHER, 5/16" SAE FLAT	F05011-17	2	
35	BOLT, 5/16-18 X 1 1/2" HEX HEAD	F05008-96	2	
36	BOLT, BLADE GUIDE VERTICAL ADJUSTMENT	035656	1	

¹ 052309 blocks for use with 1 1/2" blades provided as standard equipment or optional 1 3/4" blades. 052355 blocks available for optional use with 1 1/4" blades. EZ-Glide blocks 036347 are available for customers who prefer this block.

² F05004-60 replaced F05004-171 after 12/14/2021 per ECN 38285.

2.5 Blade Guide Assembly, Drive Side (Roller/Block, Standard)

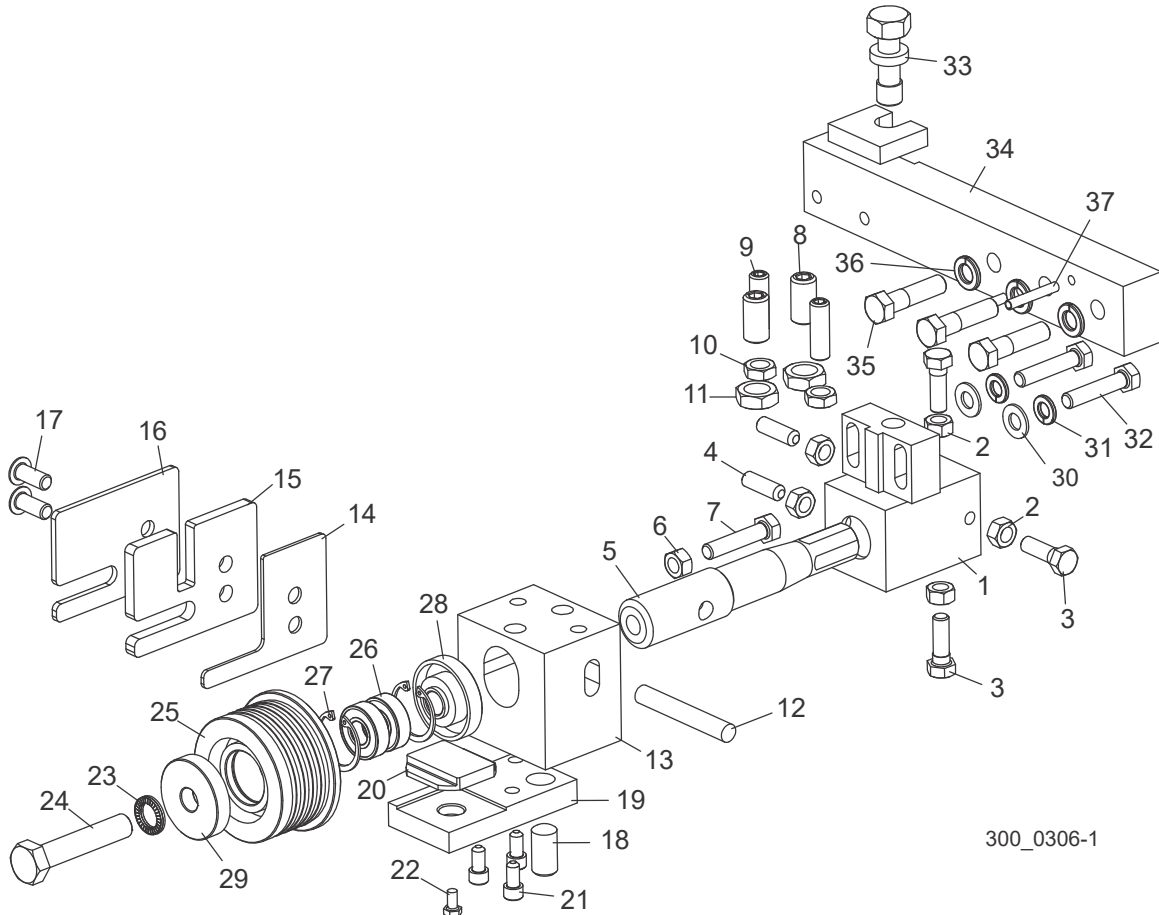

300_0306-1

REF	DESCRIPTION (◆ Indicates Parts Available In Assemblies Only)	PART #	QTY.
	ROLLER/BLOCK ASSEMBLY, INDUSTRIAL MILL DRIVE SIDE (INNER)	071354	1
	Block Assembly, Industrial Mill Blade Guide Mount	074094	1
1	Block Weldment, Industrial Mill Blade Guide Mount	062789	1
2	Nut, 5/16-18 Hex	F05010-17	5
3	Bolt, 5/16-18 x 1" Hex Head Stainless Steel	F05006-88	3
4	Screw, 5/16-18 x 1" Socket Head Flat Point Stainless Steel Set	F05006-122	1
5	Shaft, Blade Guide Roller Mount	062777	1
6	Nut, 5/16-18 Hex	F05010-17	2
7	Bolt, 5/16-18 x 1 1/2" Hex Head Full Thread Grade 5	F05006-76	3
8	Screw, 1/2-13 x 1" SS Set	F05008-186	3
9	Screw, 3/8-16 x 1 1/4" SS Set	F05007-239	2
10	Nut, 3/8-16 Jam	F05010-29	2
11	Nut, 1/2-13 Jam	F05010-31	2
12	Pin, 3/8" x 2 1-2" Harden Dowel	F05012-143	1
13	Block, Wear Pad Adjustment	062778	1

2

Blade Guides & Arm

Blade Guide Assembly, Drive Side (Roller/Block, Standard)

14	Plate, Inside Blade Shield	071356	1	
15	Plate, Middle Blade Shield	062787	1	
16	Plate, Outside Blade Shield	062788	1	
17	Screw, 5/16-18 x 3/4" BHSC SS	F05006-84	2	
18	Screw, 1/2-13 x 1" SS Set	F05008-186	3	
19	Bloc, Drive Side Pad Holder	062791	1	
20	Wear Pad, 1.5 Blade Guide	052309	1	
21	Screw, 1/4-20 x 1/2" SHC	F05005-39	3	
22	Bolt, #10-32 x 3/8" HH SS	F05004-171	1	
23	Washer, 1/2" Nord-Lock	F05011-125	1	
24	Bolt, M12-1.75 x 60 HH CL10.9	F05023-8	1	
	Roller, TVS Blade Guide	500561	1	
25	Roller, TVS Blade Guide Wide	500560	1	
26	Bearing, 6001 2RSR	087893	2	
27	Ring, W28 Inside Retaining	F81090-9	2	
28	Ring, Zinc-Plated Spacer (For Ext. Roll)	087892-1	1	
29	Ring, Zinc-Plated Spacer (For Ext. Roll)	087891-1	1	
30	Washer, 5/16" SAE Flat	F05011-17	2	
31	Washer, 5/16" Split Lock	F05011-13	2	
32	Bolt, 5/16-18 x 1 1/2" Hex Head Full Thread Grade 5	F05006-76	2	
33	Bolt, Blade Guide Vertical Adjustment	035656	1	
34	ARM WELDMENT, DRIVE SIDE BLADE GUIDE	074987	1	
35	BOLT, 1/2-20 X 1 1/2" HEX HEAD GRADE 5	F05008-53	3	
36	WASHER, 1/2" SPLIT LOCK	F05011-9	3	
37	PIN, 3/16X1 1/4 ROLL	F05012-16	2	

2.6 Blade Guide Assembly, Drive Side (Block, Optional)

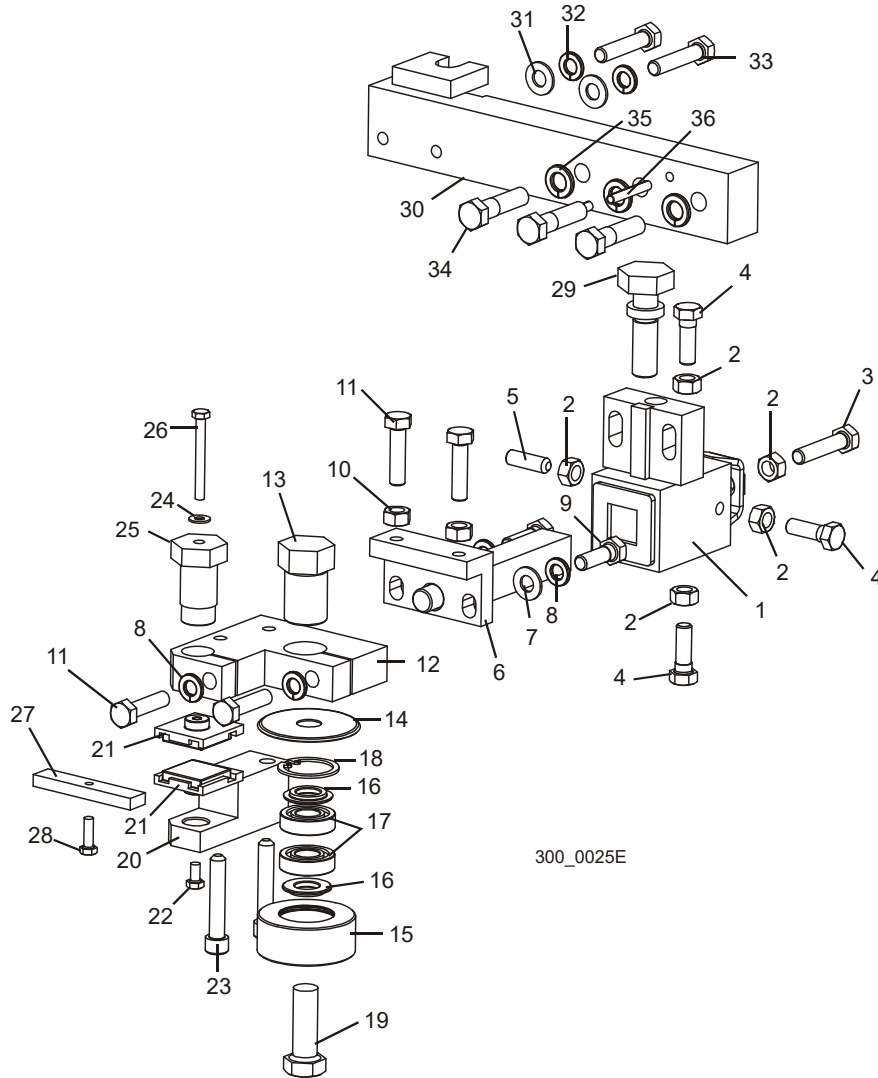

REF	DESCRIPTION (◆ Indicates Parts Available In Assemblies Only)	PART #	QTY.
	GUIDE ASSEMBLY, DRIVE SIDE BLOCK/ROLLER	035201	1
	Block Assembly, Blade Guide Mount	036100	1
1	Block Weldment, Blade Guide Mount	035219	1 ◆
2	Nut, 5/16-18 Hex	F05010-17	5
3	Bolt, 5/16-18 x 1 1/2" Hex Head Full Thread Stainless Steel	F05006-119	1
4	Bolt, 5/16-18 x 1" Hex Head Stainless Steel	F05006-88	3
5	Screw, 5/16-18 x 1" Socket Head Flat Point Stainless Steel Set	F05006-122	1
6	Shaft Weldment, Block Guide Pivot	035209	1
7	Washer, 5/16" SAE Flat	F05011-17	2
8	Washer, 5/16" Split Lock	F05011-13	4

2

Blade Guides & Arm*Blade Guide Assembly, Drive Side (Block, Optional)*

9	Bolt, 5/16-18 x 1" Hex Head Stainless Steel	F05006-88	2	
10	Nut, 5/16-18 Hex	F05010-17	2	
11	Bolt, 5/16-18 x 1 1/4" Hex Head Stainless Steel	F05006-118	4	
12	Block Weldment, Upper Blade Guide	035207	1	
13	Bolt, Blade Guide Roller Mount	035215	1	
14	Hood, Blade Guide Back Roller	042848	1	
	Roller Assembly, Blade Guide	023977	1	
15	Housing, Blade Guide Roller	017223	1	◆
16	Spacer, Blade Guide Roller	018948	2	
17	Bearing, R8-2RS Blade Guide	015975	2	
18	Ring, 1 1/8" IR 3000x112 Retaining	F04254-1	1	
19	Bolt, 1/2-13 x 1 1/2" Hex Head	F05008-4	1	
20	Block, Lower Blade Guide	035214	1	
21	Block, Blade Guide Wear (Standard for 1 1/2" or 1 3/4" Blades)	052309 ¹	2	
	Block, Blade Guide Wear (Optional for 1 1/4" Blades)	052355 ¹	2	
	Disk Assembly, 1" Sq. EZ-Glide Wear	036347 ¹	2	
22	Screw, #10-32 x 3/8" Hex Head Stainless Steel	F05004-171	1	
23	Screw, 5/16-18 x 1 3/4" Socket Head	F05006-65	2	
24	Washer, #10 Brass	042867	1	
25	Bolt, Blade Guide Block Mount	035216	1	
26	Bolt, #10-32 x 1 3/4" Hex Head Stainless Steel	F05004-178	1	
27	Block, Blade Guide Alignment	035799	1	
28	Screw, #10-32 x 5/8" Hex Head	F05004-152	1	
29	BOLT, BLADE GUIDE VERTICAL ADJUSTMENT	035656	1	
30	ARM WELDMENT, DRIVE SIDE BLADE GUIDE MOUNT	074987	1	
31	WASHER, 5/16" SAE FLAT	F05011-17	2	
32	WASHER, 5/16" SPLIT LOCK	F05011-13	2	
33	BOLT, 5/16-18 X 1 1/2" HEX HEAD FULL THREAD STAINLESS STEEL	F05006-119	2	
34	BOLT, 1/2-20 X 1 1/2" HEX HEAD GRADE 5	F05008-53	3	
35	WASHER, 1/2" SPLIT LOCK	F05011-9	3	
36	PIN, 3/16" X 1 1/4" ROLL	F05012-16	2	

¹ 052309 blocks for use with 1 1/2" blades provided as standard equipment or optional 1 3/4" blade. 052355 blocks available for optional use with 1 1/4" blades. EZ-Glide blocks 036347 are available for customers who prefer this block.

2.7 Blade Guide Arm

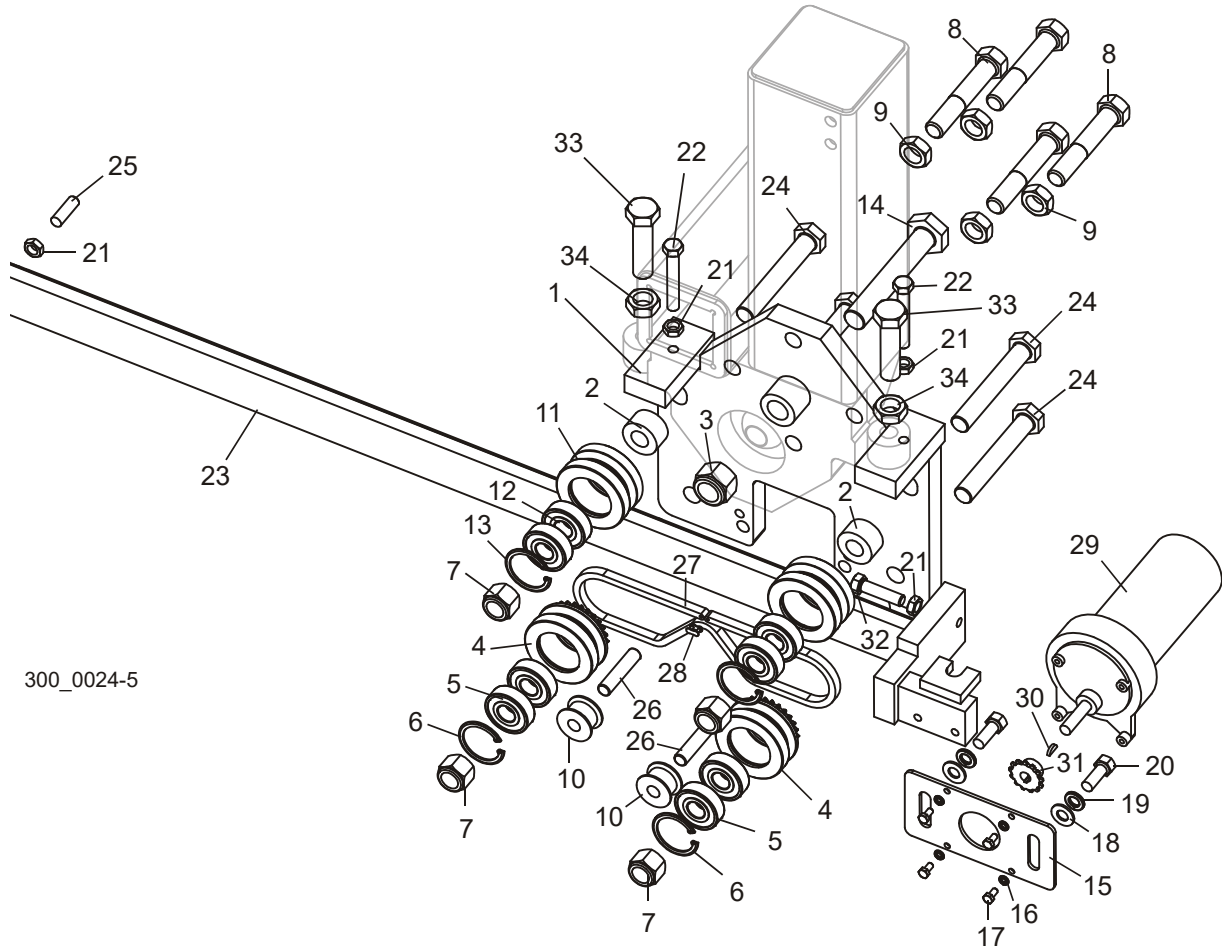

REF	DESCRIPTION (◆ Indicates Parts Available In Assemblies Only)	PART #	QTY.
	PLATE ASSEMBLY, BLADE GUIDE ARM (WM3500/WM4000/WM4500)	006703	1
	Blade Guide Parts (See Section 2.4)		
1	Plate Weldment, Blade Guide Arm	042539	1
2	Spacer, .625" x .717" x 1 1/4"	042531	4
3	Nut, 3/4-16 Hex Nylon Lock	F05010-157	1
	Roller Assembly, Blade Guide Arm Drive	042542	2
4	Roller, Blade Guide Arm W/Sprocket	042541	1
5	Bearing, 5/8" x 1.5748" x .4724"	P06030-1	2
6	Ring, 1.575" ID Beveled 5002-156 Retaining	F04254-8	1
7	Nut, 5/8-18 Hex Nylon Lock	F05010-71	4
8	Bolt, 5/8-16 x 3 1/2" Hex Head Full Thread	F05009-16	4
9	Nut, 5/8-18 Hex Jam	F05010-11	4
10	Roller, Chain Idler	S09999	2
	Roller Assembly, Blade Guide Arm Idle	042543	2

2

Blade Guide Rollers & Arm*Blade Guide Arm*

11	Roller, 2 1/2" V-Groove	042536	1	◆
12	Bearing, 5/8" x 1.5748" x .4724"	P06030-1	2	
13	Ring, 1.575" ID Beveled 5002-156 Retaining	F04254-8	1	
14	Bolt, 3/4-16 x 4 1/2" Hex Head Grade 8	F05009-97	1	
15	Plate, Blade Guide Arm Motor Mount	042519	1	
16	Washer, #10 Split Lock	F05011-20	4	
17	Screw, #10-32 x 1/2" Hex Head Machine	F05004-60	4	
18	Washer, 3/8" SAE Flat	F05011-3	2	
19	Washer, 3/8" Split Lock	F05011-4	2	
20	Bolt, 3/8-16 x 1" Hex Head	F05007-7	2	
21	Nut, 3/8-16 Hex Jam	F05010-29	3	
22	Bolt, 3/8-16 x 2 1/2" Hex Head Full Thread Grade 2	F05007-157	2	
23	Arm Weldment, WM3500 Blade Guide	006704	1	
24	Bolt, 5/8-18 x 3 1/4" Hex Head Grade 5	F05009-98	4	
25	Screw, 3/8-16 x 1 1/4" Socket Head Oval Point Set	F05007-18	1	
26	Pin, 7/16" x 2" Dowel	F05012-110	2	
27	Chain, #25 x 92 Pitch	042443	1	
28	Link, #25 Master	P09983	1	
29	Motor Assembly, 24V 60RPM Gear	035659	1	
	Motor, 24V 1/15HP Gear	033119	1	
	Housing, Klauber Motor End	P12756	1	
	Shaft, Blade Guide Arm Gear Motor	036514	1	
	Gear Kit, Blade Guide Arm Gear Motor	036515	1	
30	Key, #304 Woodruff	036203	1	
31	Sprocket, 25B13x 3/8" w/Set Screw	033120	1	
32	Bolt, 3/8-16 x 1 1/2" Hex Head Full Thread	F05007-17	1	
33	BOLT, 5/8-18 X 2 1/2" HEX HEAD FULL THREAD GRADE 5	F05009-99	2	
34	NUT, 5/8-18 HEX JAM	F05010-11	2	

SECTION 3 BLADE WHEELS & TENSIONER

3.1 Drive Shaft Assembly

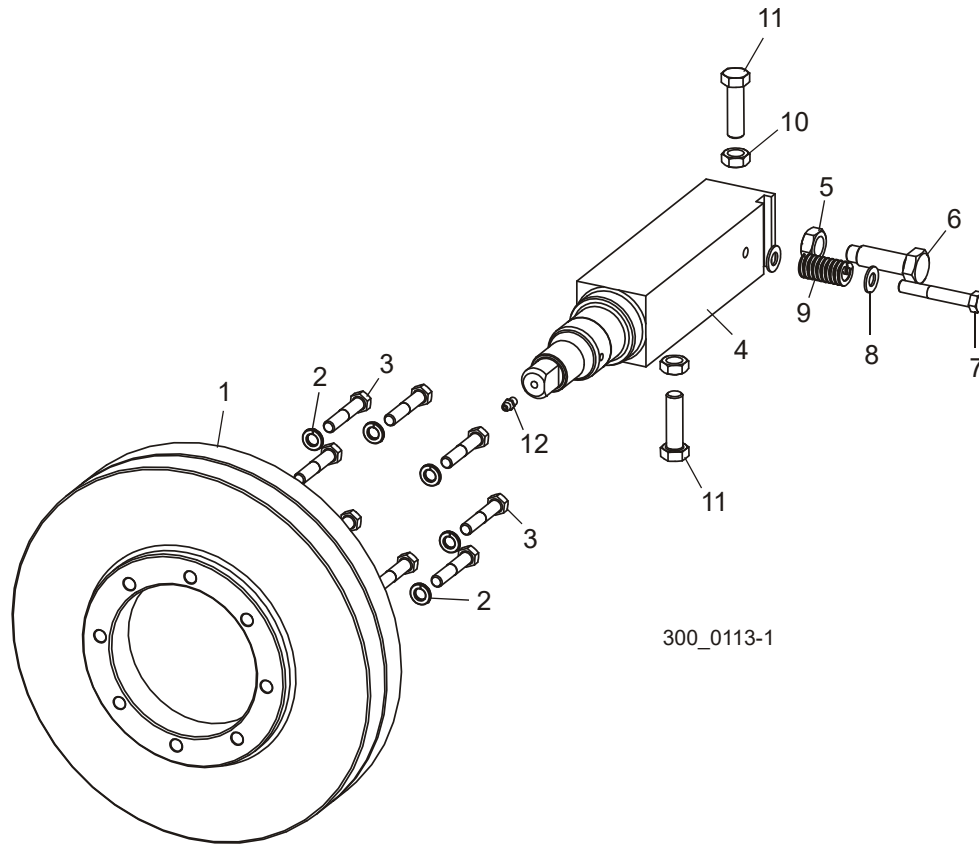

300_0113-1

REF	DESCRIPTION (◆ Indicates Parts Available In Assemblies Only)	PART #	QTY.
1	SHEAVE, EAGLE PD DRIVE	046897	1
2	WASHER, 3/8" SPLIT LOCK	F05011-4	8
3	BOLT, 3/8-16 X 2" HEX HEAD GRADE 5	F05007-124	8
4	SHAFT, BLADE WHEEL	017824	1
5	BOLT, DRIVE WHEEL SHAFT RETAINING	034360	1
6	NUT, 5/8-18 HEX JAM	F05010-11	1
7	BOLT, 3/8-16 X 2 1/2" HEX HEAD	F05007-47	1
8	WASHER, 3/8" SAE FLAT	F05011-3	2
9	SPRING, 3/4" OD X 1 1/2" DIE	034430	1
10	BOLT, 1/2-20 X 1 3/4" HEX HEAD FULL THREAD	F05008-127	2
11	NUT, 1/2-20 HEX JAM	F05010-16	2
12	FITTING, 1/4-28 GREASE	P05060	1

3 Blade Wheels & Tensioner

Idle Shaft/Brake Drum

3.2 Idle Shaft/Brake Drum

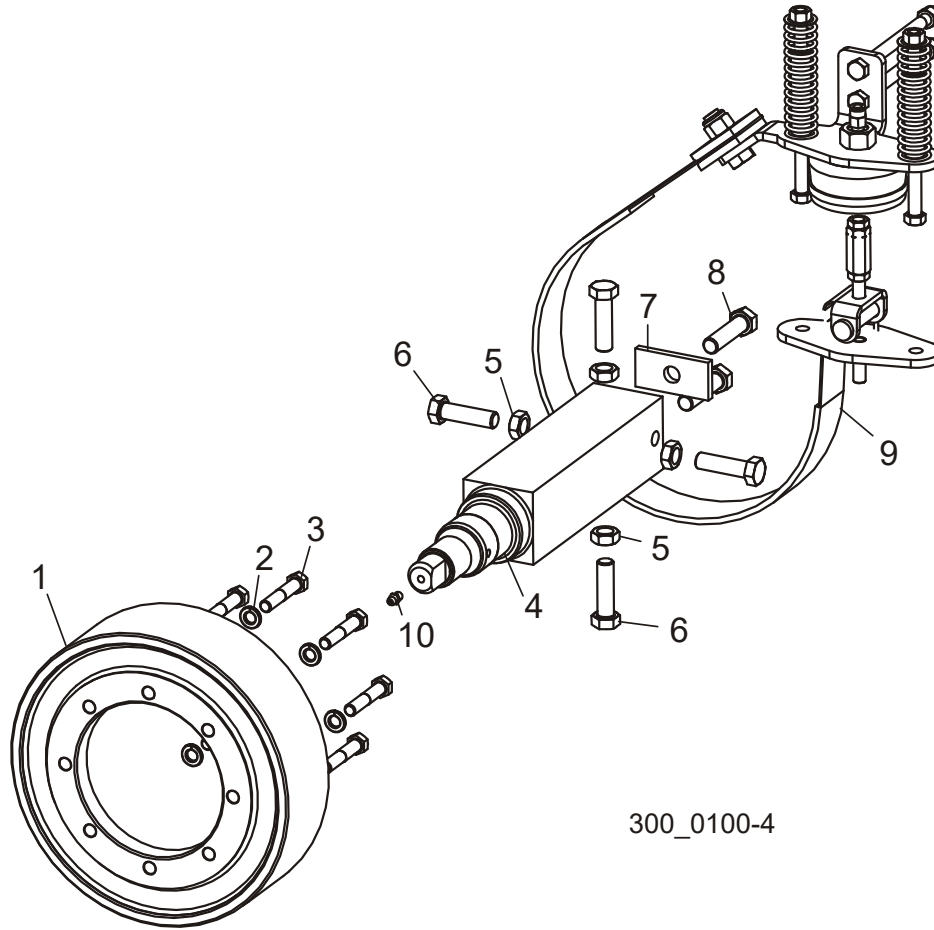

300_0100-4

REF	DESCRIPTION (◆ Indicates Parts Available In Assemblies Only)	PART #	QTY.
1	DRUM, BRAKE	045004	1
2	WASHER, 3/8" SPLIT LOCK	F05011-4	8
3	BOLT, 3/8-16 X 1 3/4" HEX HEAD GRADE 5	F05007-119	8
4	SHAFT, BLADE WHEEL	033244	1
5	NUT, 1/2-20 HEX JAM	F05010-16	4
6	BOLT, 1/2-20 X 1 3/4" HEX HEAD FULL THREAD	F05008-127	4
7	PLATE, WASHER	042548	1
8	BOLT, 1/2-20 X 2" HEX HEAD FULL THREAD	F05008-126	2
9	BRAKE ACTUATOR & STRAP PARTS (See Section 3.5)		
10	FITTING, 1/4-28 GREASE	P05060	1

3.3 Blade Wheel Kit, Belted (Standard)

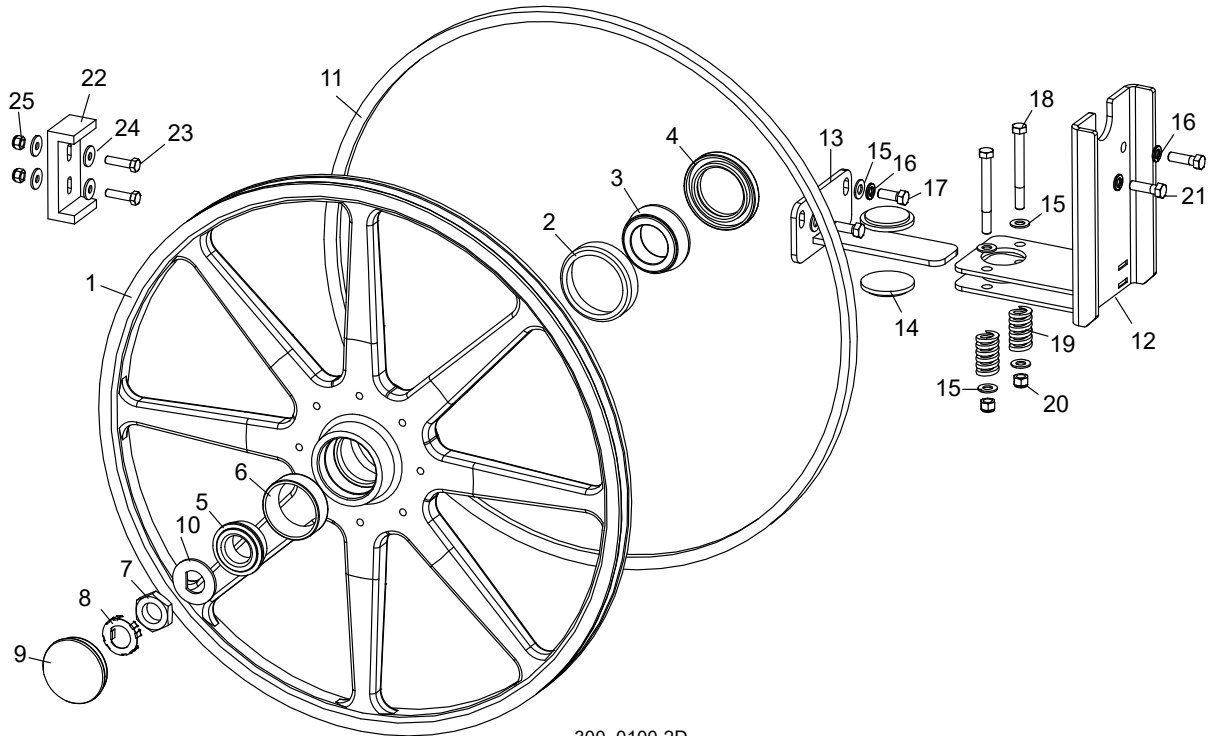

300_0100-2D

REF	DESCRIPTION (◆ Indicates Parts Available In Assemblies Only)	PART #	QTY.	
	WHEEL KIT, BELTED BLADE	036704 ¹	1	◆
	Wheel Assembly, Belted Blade w/Bearings	036632	2	
1	Wheel, 25" Belted Blade	036619	1	◆
	Bearing Kit, Blade Wheel	061227	1	
2	Race, Inner Bearing	045209	1	
3	Bearing, Inner	045208	1	
4	Seal, Blade Wheel Bearing	045212	1	
5	Bearing, Outer	045210	1	
6	Race, Outer Bearing	045211	1	
	Nut Assembly, Spindle w/Retainer	007656	1	
7	Nut, 1-14 Spindle	007654	1	◆
8	Retainer, Spindle Nut	007655	1	◆
9	Cap, Hub Dust	033238	1	
10	Washer, Blade Wheel Shaft D	045214	1	
11	Belt, B75.5	035953-1	1	
	Dampener Kit, Anti-Vibration	036840	1	
12	Mount Weldment, Dampener Pad	036838	1	
13	Tab Weldment, Dampener	036839	1	
14	Pad, Dampener	036833	2	

3

Blade Wheels & Tensioner

Blade Wheel Kit, Belted (Standard)

15	Washer, 3/8" SAE Flat	F05011-3	6	
16	Washer, 3/8" Split Lock	F05011-4	4	
17	Bolt, 3/8-16 x 1" Hex Head Grade 5	F05007-87	2	
18	Bolt, 3/8-16 x 3 1/2" Hex Head Grade 5	F05004-123	2	
19	Spring, 1" OD x 1/2" ID x 1 3/4" Heavy Die	036849	2	
20	Nut, 3/8-16 Hex Nylon Lock	F05010-10	2	
21	Bolt, 3/8-16 x 1 1/4" Hex Head Grade 5	F05007-123	2	
	Support Kit, Middle Blade	038493	1	
22	Support Channel, Middle Blade	038491	1	
23	Bolt, 5/16-18 x 1 1/4" Stainless Steel hex Head	F05006-118	2	
24	Washer, 5/16" Flat	F05011-16	4	
25	Nut, 5/16-18 Hex Nylon Lock	F05010-58	2	

¹ Belted blade wheels and block/roller blade guides provided standard. [See Section 3.4](#) for optional crowned blade wheels used with all-block blade guides. Blade wheels are too heavy to ship together in kit 036704. Order 036632 separately for service. To convert to crowned steel wheels and all-block blade guides, use two 017814 crowned wheel assemblies and one 036706 block blade guide kit.

3.4 Blade Wheel Kit, Crowned (Optional)

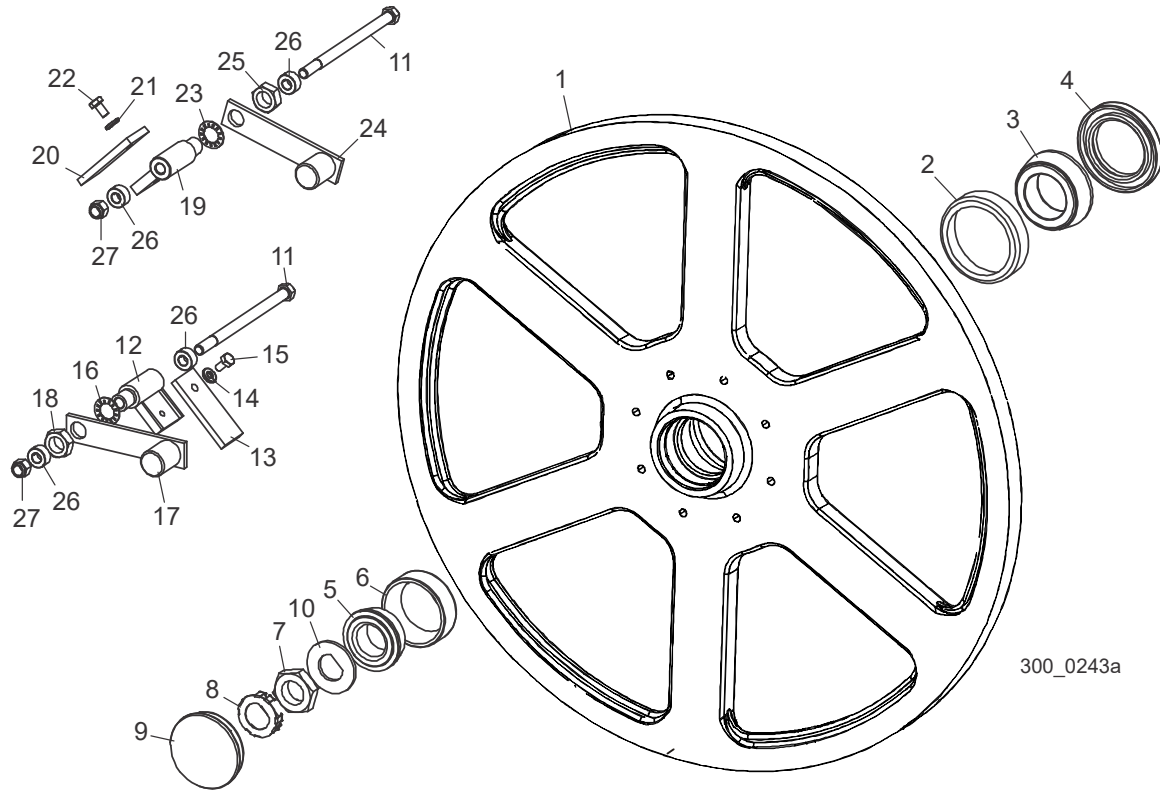

REF	DESCRIPTION (◆ Indicates Parts Available In Assemblies Only)	PART #	QTY.	
	WHEEL KIT, CROWNED BLADE (TWO COMPLETE BLADE WHEELS)	036703 ¹	1	◆
	Wheel Assembly, Blade w/Bearings	017814 ²	2	
1	Wheel, 25" Cast Blade	045000	1	◆
	Bearing Kit, Blade Wheel	061227	1	
2	Race, Inner Bearing	045209	1	
3	Bearing, Inner	045208	1	
4	Seal, Blade Wheel Bearing	045212	1	
5	Bearing, Outer	045210	1	
6	Race, Outer Bearing	045211	1	
	Nut Assembly, Spindle w/Retainer	007656	1	
7	Nut, 1-14 Spindle	007654	1	◆
8	Retainer, Spindle Nut	007655	1	◆
9	Cap, Hub Dust	033238	1	
10	Washer, Blade Wheel Shaft D	045214	1	
11	Bolt, 3/8-16 x 6" Hex Head	F05007-45	2	
	Scraper Assembly, Drive Side Blade Wheel	042247	1	
12	Pivot Weldment, Wheel Scraper	042240	1	

3

Blade Wheels & Tensioner

Blade Wheel Kit, Crowned (Optional)

13	Scraper, Brass Wheel	042245	1	
14	Washer, 1/4" Split Lock	F05011-14	1	
15	Bolt, 1/4-20 x 1/2" Hex Head	F05005-15	1	
16	Washer, 5/8" Interior Star Lock	F05011-25	1	
17	Weight Weldment, Wheel Scraper	042248	1	
18	Nut, 5/8-11 Hex Jam	F05010-82	1	
	Scraper Assembly, Idle Side Blade Wheel	042246	1	
19	Pivot Weldment, Wheel Scraper	042240	1	
20	Scraper, Brass Wheel	042245	1	
21	Washer, 1/4" Split Lock	F05011-14	1	
22	Bolt, 1/4-20 x 1/2" Hex Head	F05005-15	1	
23	Washer, 5/8" Interior Star Lock	F05011-25	1	
24	Weight Weldment, Wheel Scraper	042248	1	
25	Nut, 5/8-11 Hex Jam	F05010-82	1	
26	Collar, 3/8" ID	042249	4	
27	Nut, 3/8-16 Hex Nylon Lock	F05010-10	2	

¹ Belted blade wheels and block/roller blade guides provided standard. [See Section 3.3](#) for standard belted blade wheels used with block/roller blade guides. Blade wheels are too heavy to ship together in kit 036703. Order 017814 separately for service. To convert to belted blade wheels and roller/block blade guides, use two 036632 belted wheel assemblies, one 036705 roller/block blade guide kit, one 038493 blade support kit and one 036841 vibration dampening retrofit (WM3000/WM3500 Rev. A1.00 - A8.00) or one 036840 vibration dampening kit (WM3000/WM3500 Rev. A9.00+ and WM4000 Rev. A1.00+).

² Dust Cap 033238, D Washer 045214 and Spindle Nut 045216 added to assembly 017814 (11/04).

3.5 Brake Assembly

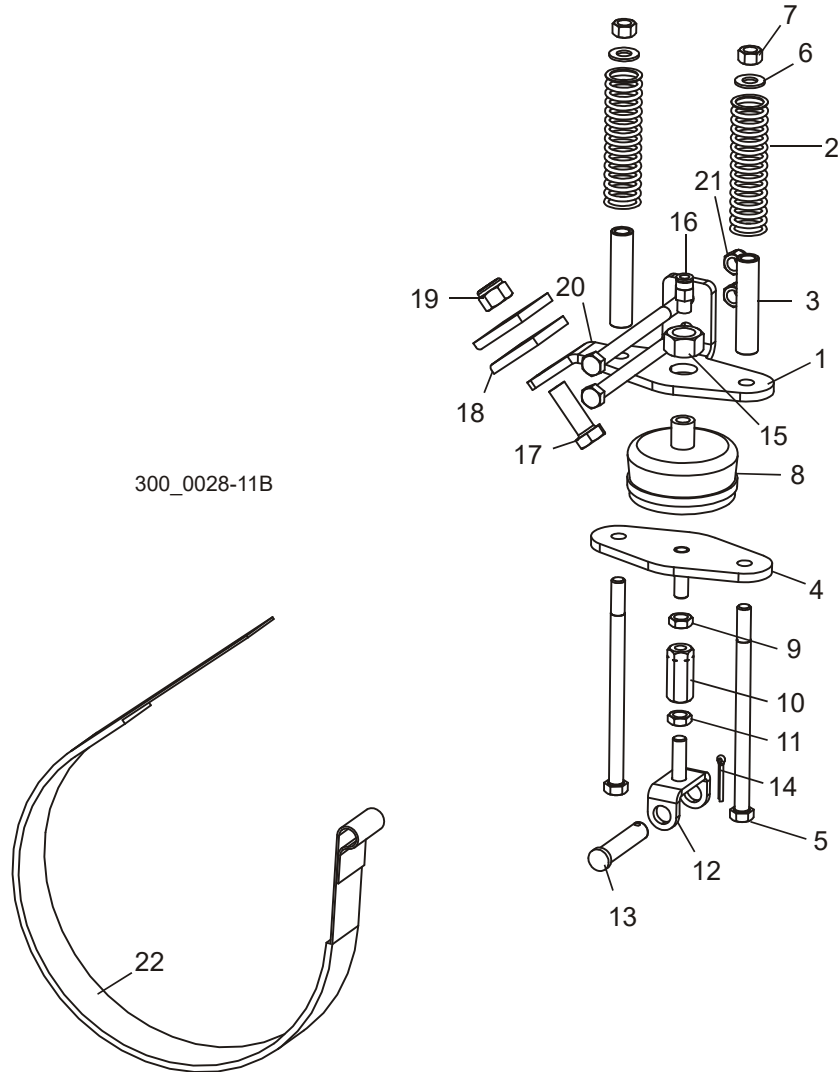

REF	DESCRIPTION (◆ Indicates Parts Available In Assemblies Only)	PART #	QTY.
	ACTUATOR ASSEMBLY, LT300 BRAKE	033170	1
1	Bracket, Upper Brake Mount	033166	1
2	Spring, Brake	033171	2
3	Spacer, Brake Spring Travel	033169	2
4	Bracket Weldment, Lower Brake Mount	033172	1
5	Bolt, 3/8-16 x 6" Hex Head	F05007-45	2
6	Washer, 3/8" SAE Flat	F05011-3	2
7	Nut, 3/8-16 Hex Lock	F05010-25	2
8	Bag, Brake Air	033168	1
9	Nut, 3/8-24 Hex Jam (Left-Hand Thread)	F05010-166	1

3**Blade Wheels & Tensioner***Brake Assembly*

10	Adjuster, Brake Link	033174	1	
11	Nut, 3/8-24 Hex Jam	F05010-22	1	
12	Bracket Weldment, Brake Link	033175	1	
13	Pin, 1/2" x 2 1/4" Clevis	F05012-81	1	
14	Pin, 1/8" x 1" Cotter	F05012-1	1	
15	Nut, 5/8-11 Hex	F05010-5	1	
16	Fitting, 1/8" NPT x 1/4" Tube	P03078	1	
17	Bolt, 1/2-13 x 1 1/2" Hex Head	F05008-4	1	
18	Plate, Brake Strap Clamp	S04195	2	
19	Nut, 1/2-13 Hex Nylon Lock	F05010-8	1	
20	Bolt, 3/8-16 x 5" Hex Head Grade 2	F05007-5	2	
21	Nut, 3/8-16 Hex Nylon Lock	F05010-10	2	
22	Strap, 9 1/2" Dia. Brake	033178	1	

SECTION 4 SAW HEAD

4.1 Board Return

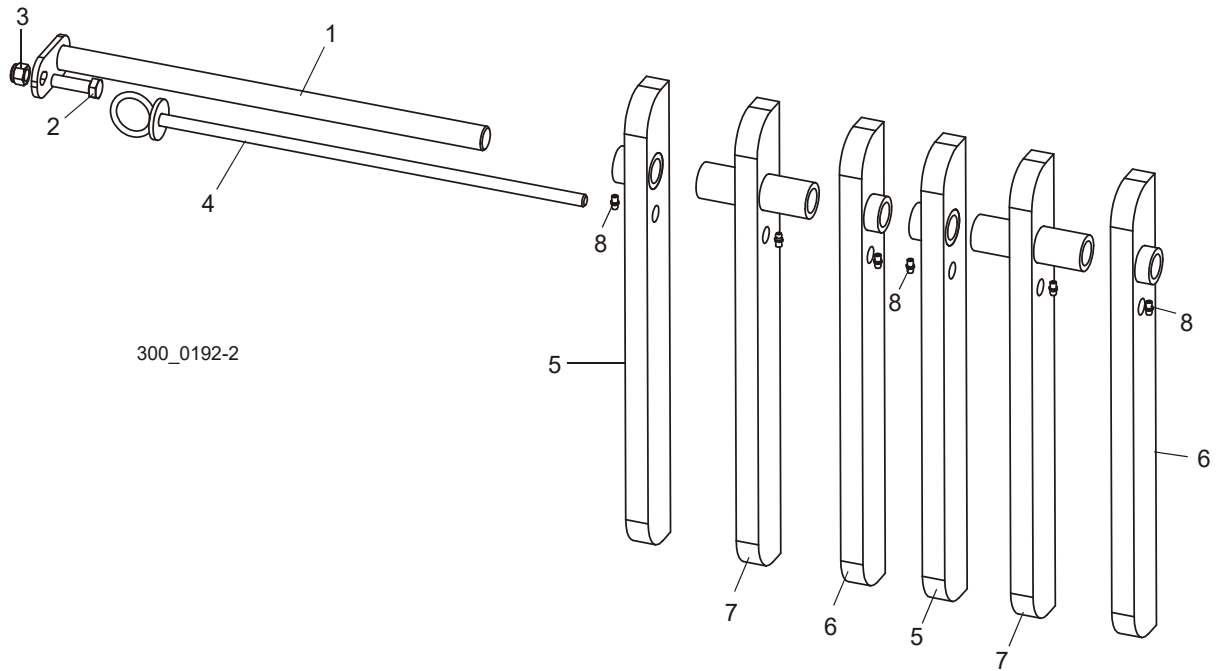

REF	DESCRIPTION (◆ Indicates Parts Available In Assemblies Only)	PART #	QTY.	
1	PIN WELDMENT, BOARD RETURN PIVOT	042167	1	
2	BOLT, 1/2-13 X 1 3/4" HEX HEAD GRADE 5	F05008-88	1	
3	NUT, 1/2-13 HEX NYLON LOCK	F05010-8	1	
4	PIN WELDMENT, SUPPORT	042168	1	
5	ARM WELDMENT, LEFT BOARD RETURN	003659	2	
6	ARM WELDMENT, RIGHT BOARD RETURN	003660	2	
7	ARM WELDMENT, MIDDLE BOARD RETURN	003661	2	
8	FITTING, 1/4-28 GREASE	P05060	6	

4 Saw Head

Board Return Guide

4.2 Board Return Guide

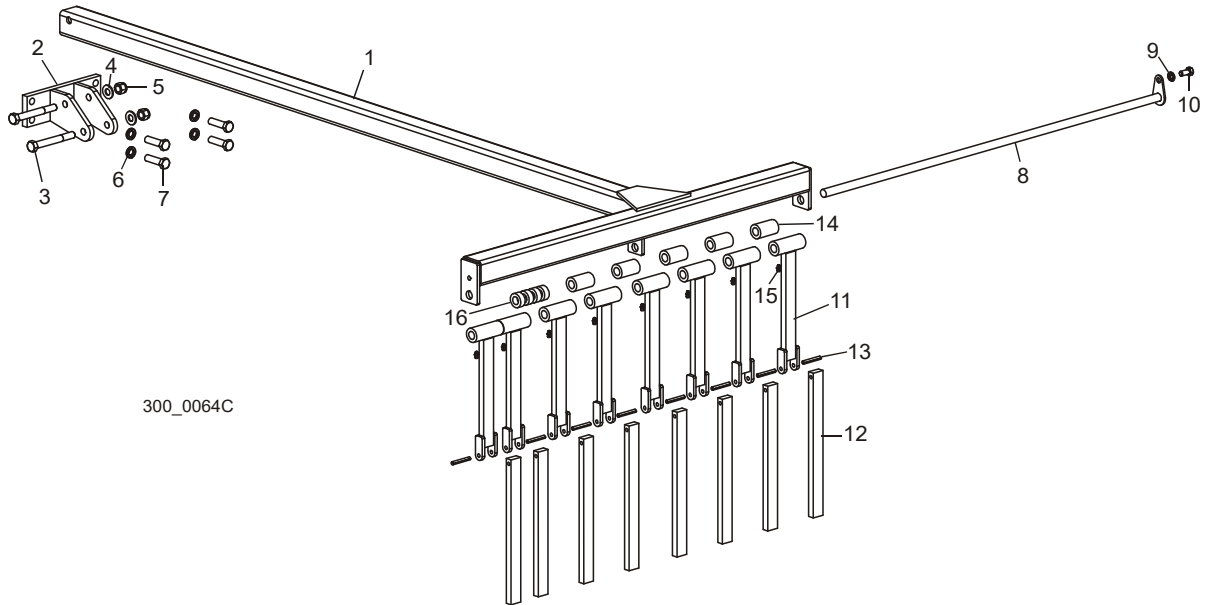

REF	DESCRIPTION (◆ Indicates Parts Available In Assemblies Only)	PART #	QTY.
	GUIDE ASSEMBLY, BOARD RETURN	017808	1
1	Guide Weldment, Board Return	017809	1
2	Bracket Weldment, Board Return Guide Mount	017811	1
3	Bolt, 1/2-13 x 4" Hex Head	F05008-26	2
4	Washer, 1/2" SAE Flat	F05011-2	2
5	Nut, 1/2-13 Hex Nylon Lock	F05010-8	2
6	Washer, 1/2" Split Lock	F05011-9	4
7	Bolt, 1/2-13 1 3/4" Hex Head Grade 5	F05008-88	4
8	Rod Weldment, Board Return Guide	034408	1
9	Washer, 3/8" Split Lock	F05011-4	1
10	Bolt, 3/8-16 x 3/4" Hex Head Grade 5	F05007-118	1
11	Bar Weldment, Board Guide Upper	017823	8
12	Bar, Board Guide Lower	017822	8
13	Pin, 1/4" x 1 3/4" Roll	F05012-53	8
14	Tube, Board Guide Spacer	017820	5
15	Fitting, 3/16" x 3/16" Straight Grease	P04107	8
16	Tube, Board Guide Spacer (.46")	003687	4

4.3 Covers & Sawdust Chute

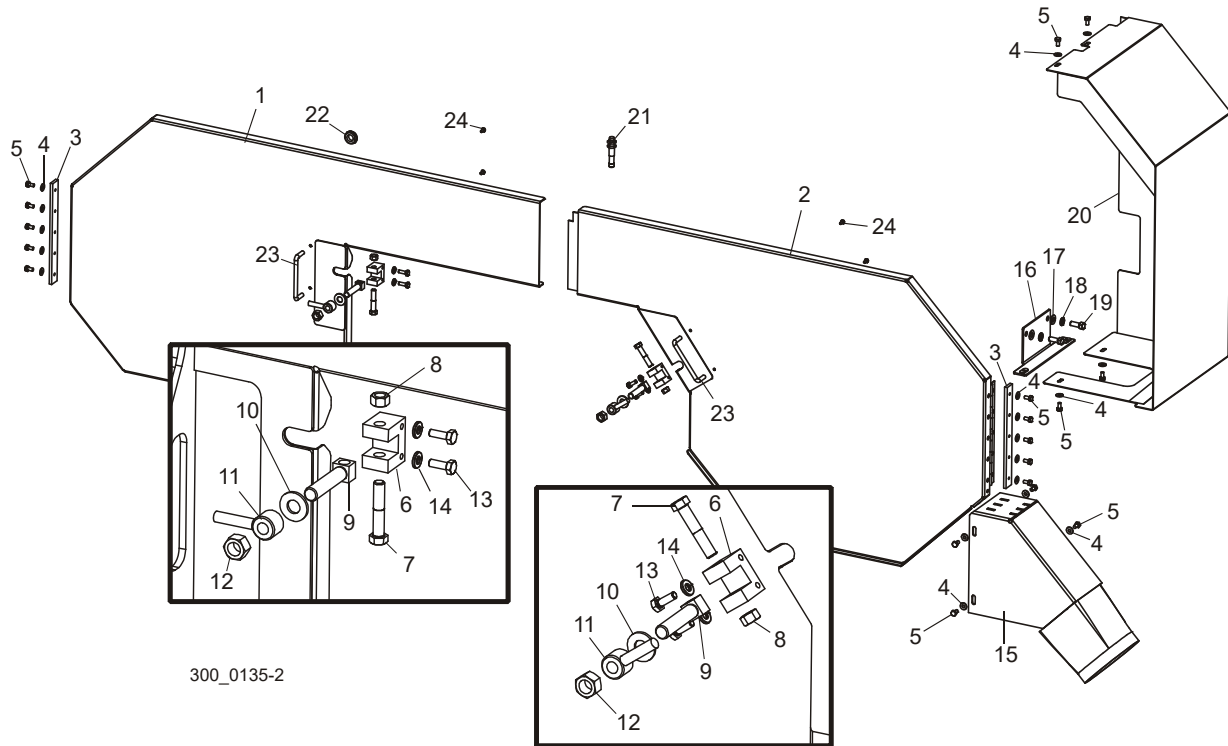

300_0135-2

REF	DESCRIPTION (◆ Indicates Parts Available In Assemblies Only)	PART #	QTY.
1	COVER WELDMENT, IDLE SIDE BLADE HOUSING	006638	1
2	COVER WELDMENT, DRIVE SIDE BLADE HOUSING	038981	1
3	PLATE, COVER MOUNT	042435	2
4	WASHER, 1/4" SAE FLAT	F05011-11	18
5	BOLT, 1/4-20 X 1/2" HEX HEAD	F05005-15	18
	LATCH ASSEMBLY, BLADE HOUSING COVER	042440	2
6	Block, Cover Latch	042439	1
7	Bolt, 3/8-16 x 2" Hex Head	F05007-72	1
8	Nut, 3/8-16 Hex Lock	F05010-25	1
9	Bolt, Cover Latch	042438	1
10	Washer, 1/2" SAE Flat	F05011-2	1
11	Handle Weldment, Cover Latch	021145	1
12	Nut, 1/2-13 Hex Lock	F05010-3	1
13	BOLT, 1/4-20 X 3/4" HEX HEAD FULL THREAD	F05005-1	4
14	WASHER, 1/4" SPLIT LOCK	F05011-14	4
15	CHUTE WELDMENT, SAWDUST	045005	1
16	BRACKET WELDMENT, SIDE GUARD MOUNT	036847	1

4**Saw Head***Covers & Sawdust Chute*

17	WASHER, 3/8" SAE FLAT	F05011-3	2	
18	WASHER, 3/8" SPLIT LOCK	F05011-4	2	
19	BOLT, 3/8-16 X 1" HEX HEAD GRADE 5	F05007-87	2	
20	GUARD WELDMENT, SIDE	036845	1	
21	SENSOR, 12MM EXTENDED PROXIMITY (FOR WM3500 ONLY)	025041	1	
	SENSOR, IND PROX M12 PNP NS EX (FOR WM4000 ONLY)	051439	1	
22	GROMMET, 5/8" ID RUBBER	P11764	1	
23	HANDLE, 4" DOOR	P08065	2	
24	SCREW, #8-32 X 3/8" SELF-TAPPING	F05015-8	4	

4.4 Blow-Off Assembly

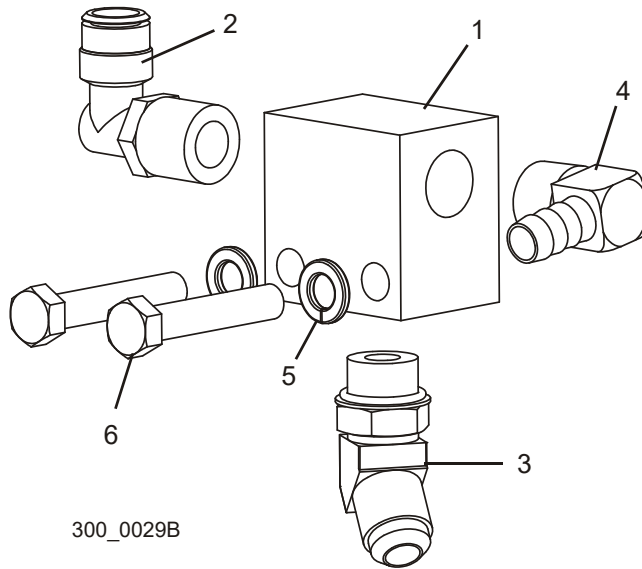

REF	DESCRIPTION (◆ Indicates Parts Available In Assemblies Only)	PART #	QTY.
	BLOCK ASSEMBLY, BLOW-OFF	016882	1
1	Block, Blow-Off	016879	1
2	Fitting, 1/2" NPT x 1/2" Tube 90° Swivel Elbow	016880	1
3	Fitting, #8 JIC x #8 SAE 45° Elbow	041161	1
4	Fitting, 1/2" NPT x 1/2" Hose Barb 90° Elbow	015997	1
5	Washer, 3/8" Split Lock	F05011-4	2
6	Bolt, 3/8-16 x 2" Hex Head Full Thread	F05007-16	2
	TUBING, 1/2" CHAINFLEX AIR LINE	R01869-5	54 Ft. ¹
	TUBING, 1/2" CHAINFLEX AIR LINE	R01869-5	4 Ft.

¹ Additional 6 foot of hose supplied for WM3500-BX6

4 Saw Head

Laser Assembly

4.5 Laser Assembly

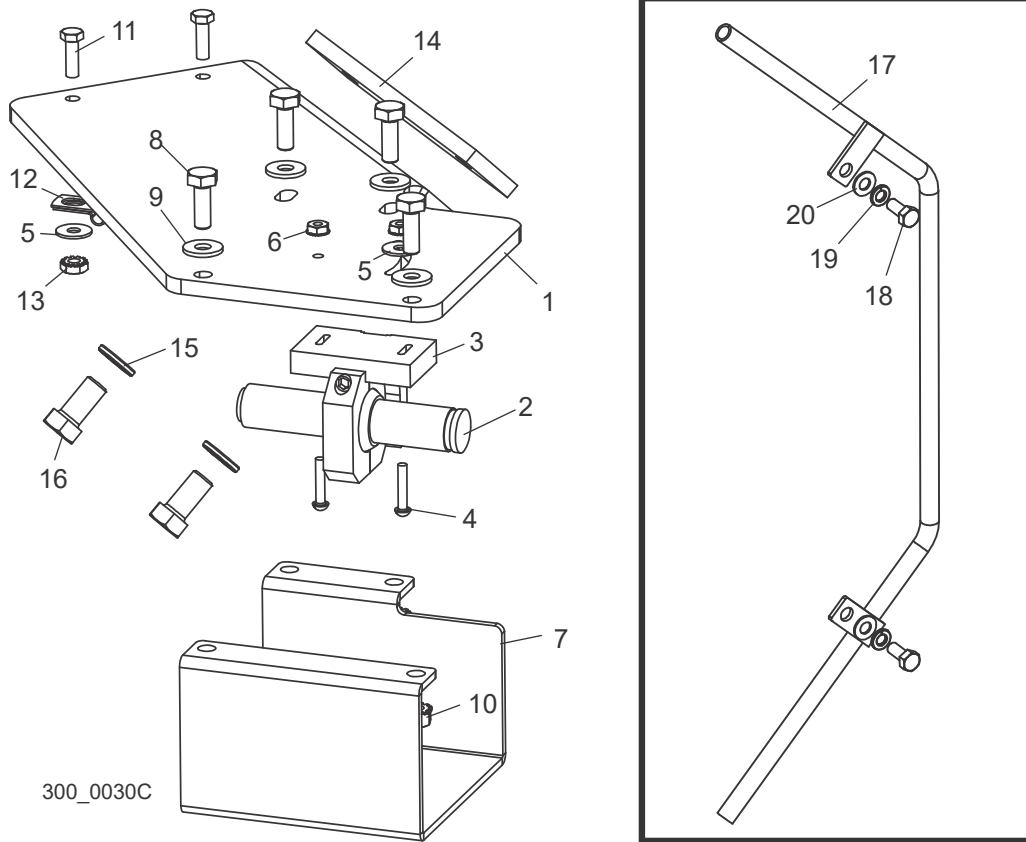

REF	DESCRIPTION (◆ Indicates Parts Available In Assemblies Only)	PART #	QTY.
	LASER ASSEMBLY, WM3500	042169	1
1	Plate, Laser Mount	042744	1
2	Laser, 15mW 635nM 60° Line w/Mounting Bracket	025125	1
3	Bracket, Laser Mount	045250	1
4	Screw, #6-32 x 3/4" Slotted Round Head	F05004-21	2
5	Washer, #10 SAE Flat	F05011-18	3
6	Nut, #6 Hex Self-Locking	F05010-59	2
7	Cover, Laser Guard	042743	1
8	Bolt, 1/4-20 x 3/4" Hex Head Full Thread	F05005-1	4
9	Washer, 1/4" SAE Flat	F05011-11	4
10	Nut, 1/4-20 Hex Self-Locking	F05010-9	4
11	Bolt, #10-24 x 5/8" Hex Head	F05004-18	2
12	Clamp, .187 Cushioned Metal Cable	025196	2
13	Nut, #10-24 Hex Self-Locking	F05010-14	2
14	Plate, Laser Mount Nut	042452	1
15	Washer, 3/8" Split Lock	F05011-4	2

16	Bolt, 3/8-16 x 3/4" Hex Head Grade 2	F05007-27	2	
17	CONDUIT WELDMENT, LASER	074784	1	
18	BOLT, 5/16-18 X 3/4" HEX HEAD GRADE 5	F05006-102	2	
19	WASHER, 5/16" SPLIT LOCK	F05011-13	2	
20	WASHER, 5/16" SAE FLAT	F05011-17	2	

4 Saw Head Decals

4.6 Decals

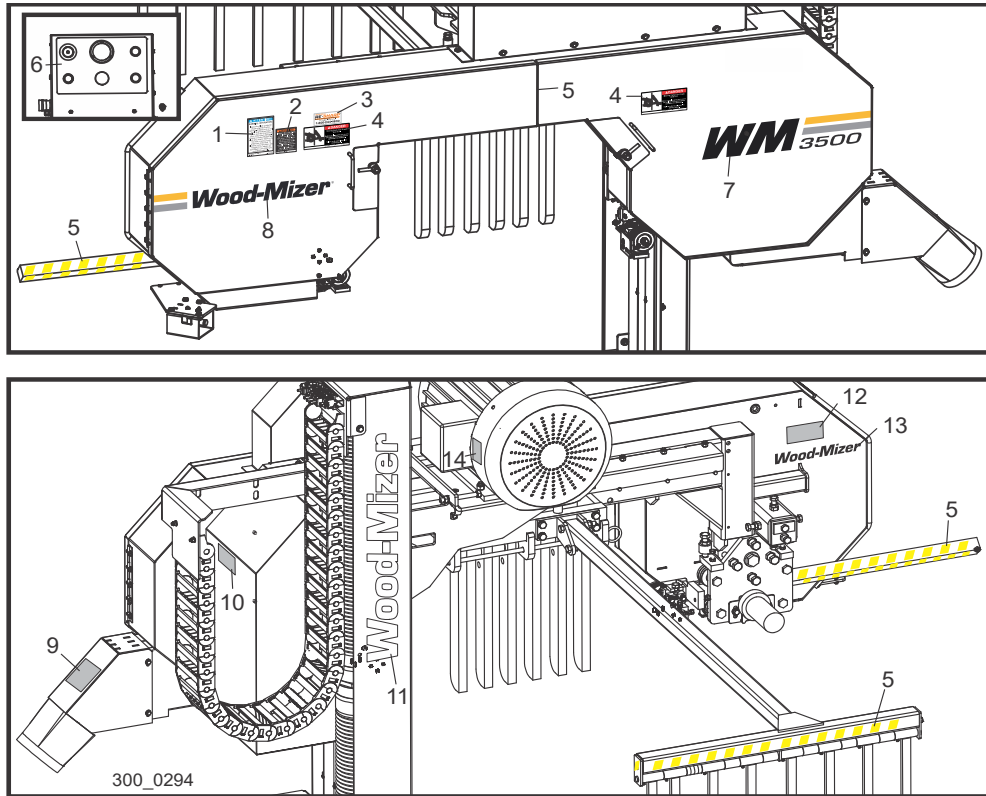

REF	DESCRIPTION (◆ Indicates Parts Available In Assemblies Only)	PART #	QTY.
1	DECAL, BLADE GUIDE INFO (LARGE)	034803	1
2	DECAL, BLADE INSPECTION WARNING	034801	1
3	DECAL, RE-SHARP	P12879	1
4	DECAL, MOVING PARTS DANGER	033254	2
5	DECAL, WARNING STRIPE	016834	7
6	DECAL, LT300 2005 HEAD/AIR BOX	052274	1
7	DECAL, WM3500 LOGO	076275	1
8	DECAL, WOOD-MIZER LOGO W/STRIPES	076273	1
9	DECAL, EYE/EAR PROTECTION WARNING	S11753	1
10	DECAL, TRANSDUCER ADJUSTMENT CAUTION	042674	1
11	DECAL, 27" WHITE WOOD-MIZER LOGO	074077	1
12	PLATE, NAME	S20038	1
13	DECAL, WOOD-MIZER LOGO 10.25"	052287	1
14	DECAL, MOTOR DIRECTION	S20097	1

4.7 Head/Air Box Control Assembly

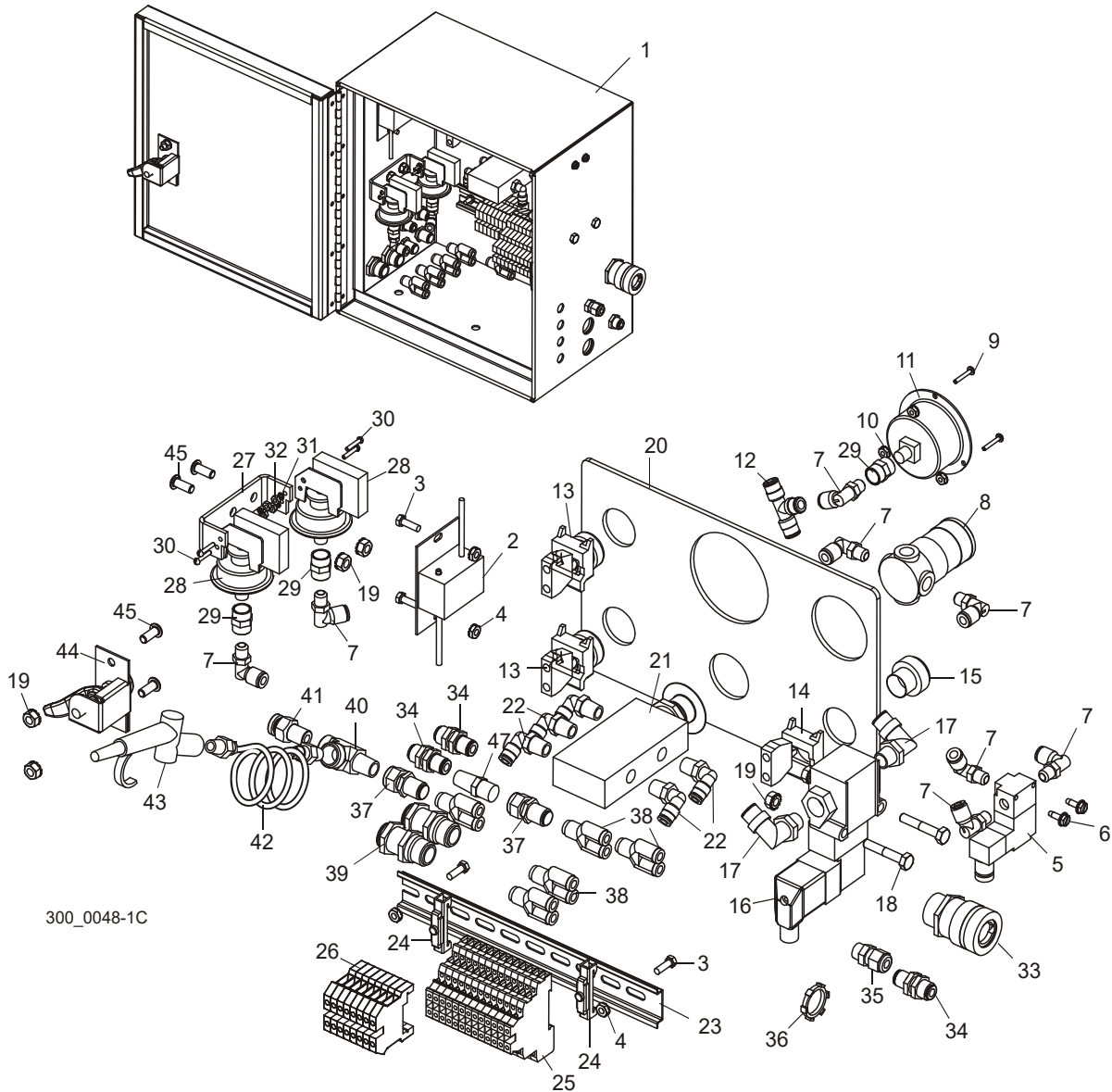

300_0048-1C

REF	DESCRIPTION (◆ Indicates Parts Available In Assemblies Only)	PART #	QTY.
	CONTROL ASSEMBLY, HEAD/AIR BOX	045244	1
1	Box Weldment, Head/Air	035569	1
2	Power Supply Assembly, Laser	052327	1
3	Screw, #10-24 x 5/8" Unslotted Indent Hex Head	F05004-18	4
4	Nut, #10-24 Hex Self-Locking	F05010-14	4
5	Valve, Air 3-Way 1/8" NPT DIN C Conn	045225	1
	Cable, 10M Form C DIN 24VDC w/LED	025233	1

4

Saw Head*Head/Air Box Control Assembly*

6	Screw, #10-24 x 1/2" Self-Tapping Slotted Hex	F05015-7	2	
7	Fitting, 1/8" MPT x 1/4" Tube Swivel Elbow	P09736	8	
8	Regulator Kit, Air	045247	1	
	Regulator, 1/8" NPT Air	052509	1	
	Nut, Regulator Mount	052510	1	
9	Screw, #6-32 x 3/4" Socket Button Head Stainless	F05004-93	3	
10	Nut, #6-32 Hex Self-Locking	F05010-59	3	
11	Gauge, Air Pressure	042342	1	
12	Fitting, 1/4" Tube 'T'	P21544	1	
13	Light, Yellow 24V 22mm LED XB4 Pilot	024970-5	2	
14	Switch, 1NO 22mm XB4	025242	1	
15	Button, 22mm Mom Ext LED Yellow XB4 Switch	025237-53	1	
16	Valve Assembly, Blow-Off	042659	1	
	Cable, 5M Form A DIN 24VDC w/LED	024923	1	
17	Fitting, 3/8" NPT x 1/2" Tube Swivel Elbow	034009	2	
18	Bolt, 1/4-20 x 1 1/2" Hex Head Full Thread	F05005-31	2	
19	Nut, 1/4-20 Hex Self-Locking	F05010-9	6	
20	Decal, Head/Air Control Box	052274	1	
21	Valve, 4-Way Push/Pull 1/4" NPT	025301	1	
22	Fitting, 1/4" NPT x 1/4" Tube Elbow	P21519	5	
23	DIN Rail, 35mm x 7.5mm x 10" Steel Sym	024474-10	1	
24	Clamp, Metal DIN Rail	E22707	2	
25	Terminal Block, 3-Tier	024908	13	
26	Terminal Block, 1-Tier	024893	8	
27	Bracket, Pressure Switch Mount	042256	1	
28	Switch, Limit Pressure 60 PSI	045207	2	
29	Fitting, 1/8" FPT Coupling	P05748	3	
30	Screw, #4-40 x 5/8" Slotted Round Head	F05004-49	4	
31	Washer, #4 Split Lock	F05011-21	4	
32	Nut, #4 Hex	F05010-43	4	
33	Connector, .75 Hole x .63-.75 Cord Flex Strain	025186	1	
	Nut, 3/4" Conduit Lock	025198	1	
34	Fitting, 1/4" x 1/4" Tube Bulkhead	025234	1	
35	Connector, .5" Hole .064-.210 Cord	E23494	1	
36	Nut, 1/2" Conduit Lock	E20461	2	
37	Fitting, 1/4" Tube x 1/4" NPT Female Bulkhead	025235	2	
38	Fitting, 1/4" Tube "Y"	042546	5	
39	Fitting, 3/8" NPT x 1/2" Tube Bulkhead	034010	2	
40	Fitting, 1/4" Male Run Tee	P09141	1	
41	Fitting, 1/4" NPT x 3/8" Tube	P21559	1	
42	Hose, 1/4" x 6' Coiled Air	042453	1	
43	Nozzle, Air Spray	P02714	1	
44	Latch, Door	P20048	1	

45	Screw, 1/4-20 x 5/8" Button Socket Head	F05005-128	4	
	Washer, 7/8" SAE Flat	F05011-73	1	
	Harness Assembly, Blade Guide	025284	1	
	Harness Assembly, Motor Prox	025286	1	
	Harness Assembly, Start Prox	025287	1	
	Harness Assembly, Slow Prox	025288	1	
	Harness Assembly, Stop Prox	025289	1	
	Hose, 1/4" Chainflex Air	R01869-3	186"	
	Hose, 1/2" Chainflex Air	R01869-5	58"	
	Cable, Oiler	025233	1	

4 Saw Head

Blade Motor Drive Assembly

4.8 Blade Motor Drive Assembly

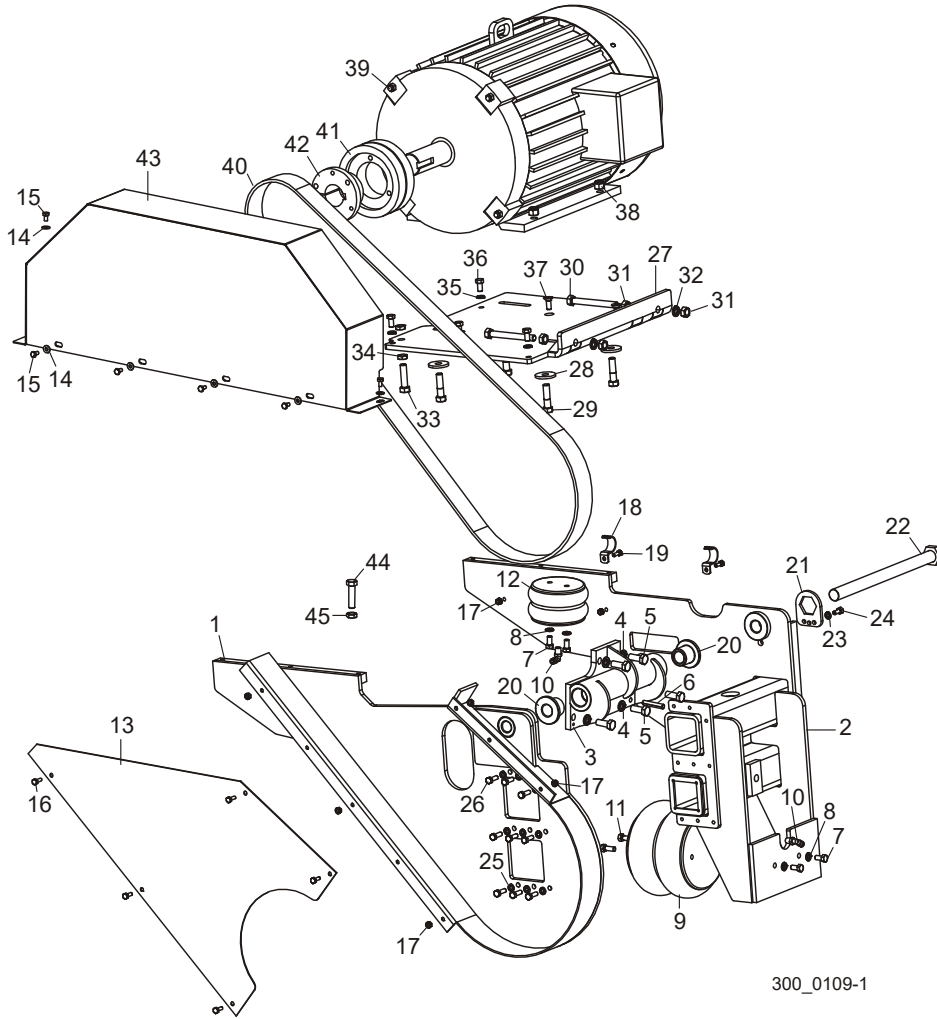

REF	DESCRIPTION (◆ Indicates Parts Available In Assemblies Only)	PART #	QTY.
1	BRACKET WELDMENT, FRONT MOTOR MOUNT	033211	1
2	BRACKET WELDMENT, REAR MOTOR MOUNT	033216	1
3	PIVOT WELDMENT, MOTOR MOUNT	033206	1
4	WASHER, 1/2" SPLIT LOCK	F05011-9	5
5	BOLT, 1/2-13 X 1 1/4" HEX HEAD GRADE 5	F05008-37	5
6	PIN, 3/8" X 2" ROLL	F05012-42	2
7	BOLT, 3/8-16 X 3/4" HEX HEAD GRADE 2	F05007-27	4
8	WASHER, 3/8" SPLIT LOCK	F050011-4	4
9	BAG, TENSIONER AIR	033229	1
10	FITTING, 1/4" NPT X 1/4" AIR 90 ELBOW	P21519	2
11	BOLT, 3/8-16 X 1" HEX HEAD GRADE 5	F05007-87	2
12	BAG, MOTOR LIFT AIR	033231	1

13	COVER, BELT	036662	1	
14	BOLT, 1/4-20 X 1/2" HEX HEAD	F05005-15	5	
15	WASHER, 1/4" SAE FLAT	F05011-11	5	
16	BOLT, 1/4-20 X 3/4" HEX HEAD	F05005-129	5	
17	NUT, 1/4-20 SELF-LOCKING HEX	F05010-9	7	
18	CLAMP, 1" EMT	P05436	2	
19	BOLT, 1/4-20 X 3/4" HEX HEAD FULL THREAD	F05005-1	2	
20	BEARING, MOTOR PIVOT	033210	2	
21	PLATE, PIVOT BOLT LOCK	033230	1	
22	BOLT WELDMENT, MOTOR PIVOT	033225	1	
23	WASHER, 5/16" SPLIT LOCK	F05011-13	1	
24	BOLT, 5/16-18 X 3/4" HEX HEAD	F05006-5	1	
25	WASHER, 5/16" SPLIT LOCK	F05011-13	9	
26	BOLT, 5/16-18 X 1" HEX HEAD GRADE 5	F05006-48	9	
	DRIVE ASSEMBLY, 30HP 480V/60HZ PD	036638	1	
	DRIVE ASSEMBLY, 30HP 480V/50HZ PD	036640 ¹	1	
27	Plate Weldment, Motor Mount	042461	1	
28	Washer, .52" ID x 1.69" OD	014632	4	
29	Bolt, 1/2-13 x 2" Hex Head	F05008-76	4	
30	Bolt, 1/2-13 x 4 1/2" Hex Head Full Thread	F05008-16	2	
31	Nut, 1/2-13 Hex	F05010-35	4	
32	Washer, 1/2" Split Lock	F05011-9	2	
33	Bolt, 1/2-13 x 2" Hex Head Full Thread	F05008-8	1	
34	Nut, 1/2-13 Hex Jam	F05010-31	2	
35	Washer, 3/8" Split Lock	F05011-4	4	
36	Bolt, 3/8-16 x 3/4" Hex Head Grade 2	F05007-27	4	
37	Bolt, 3/8-16 x 1" Flat Socket Head	F05007-64	2	
38	Nut, 1/2-13 Hex Nylon Lock	F05010-8	4	
39	Motor, 30HP 1800RPM	042301	1	
40	Belt, Eagle PD G2380	036636	1	
41	Pulley, Eagle PD G36SSF	036634	1	
	Pulley, Eagle PD G45SE (50Hz)	036635	1	
42	Bushing, SF x 1 7/8"	039266	1	
	Bushing, E x 1 7/8" (50Hz)	036637 ¹	1	
43	Cover Weldment, Belt Guard	036678	1	
44	BOLT, 1/2-13 X 2" HEX HEAD FULL THREAD	F05008-8	1	
45	NUT, 1/2-13 HEX JAM	F05010-31	1	

¹ Alternate drive belt, motor pulley and bushing for 50Hz operation.

SECTION 5 UP/DOWN SYSTEM

5.1 Mast Pads & Rollers

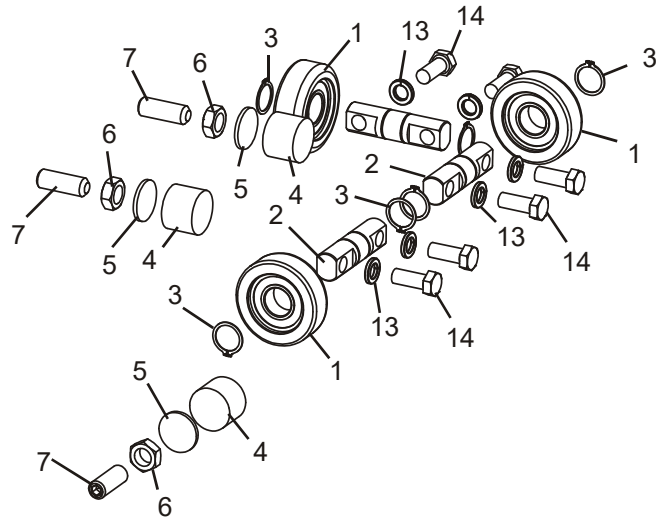

300_0028-4

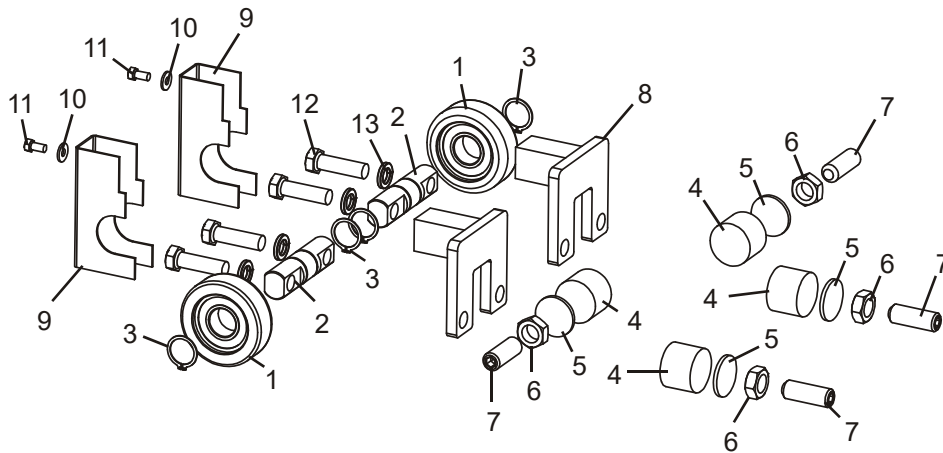

REF	DESCRIPTION (◆ Indicates Parts Available In Assemblies Only)	PART #	QTY.
1	BEARING, MG305DDA	023857	5
2	SHAFT, UP/DOWN MAST BEARING	023858	5
3	RING, 1" OUTSIDE RETAINING	F04254-15	10
4	PAD, ROUND NYLON	033098	7
5	PAD, NYLON BACKING	042432	7
6	NUT, 5/8-18 HEX JAM	F05010-11	7
7	SCREW, 5/8-18 X 1 3/4" SOCKET HEAD FLAT POINT SET	F05009-27	7
8	BRACKET WELDMENT, UP/DOWN BEARING MOUNT	045048	2
9	COVER, MAST BEARING	045047	2

10	WASHER, 1/4" SAE FLAT	F05011-11	2	
11	BOLT, 1/4-20 X 1/2" HEX HEAD	F05005-15	2	
12	BOLT, 1/2-13 X 1 3/4" HEX HEAD GRADE 5	F05008-88	4	
13	WASHER, 1/2" SPLIT LOCK	F05011-9	10	
14	BOLT, 1/2-13 X 1 1/4" HEX HEAD GRADE 5	F05008-37	6	

5.2 Bearing Rails

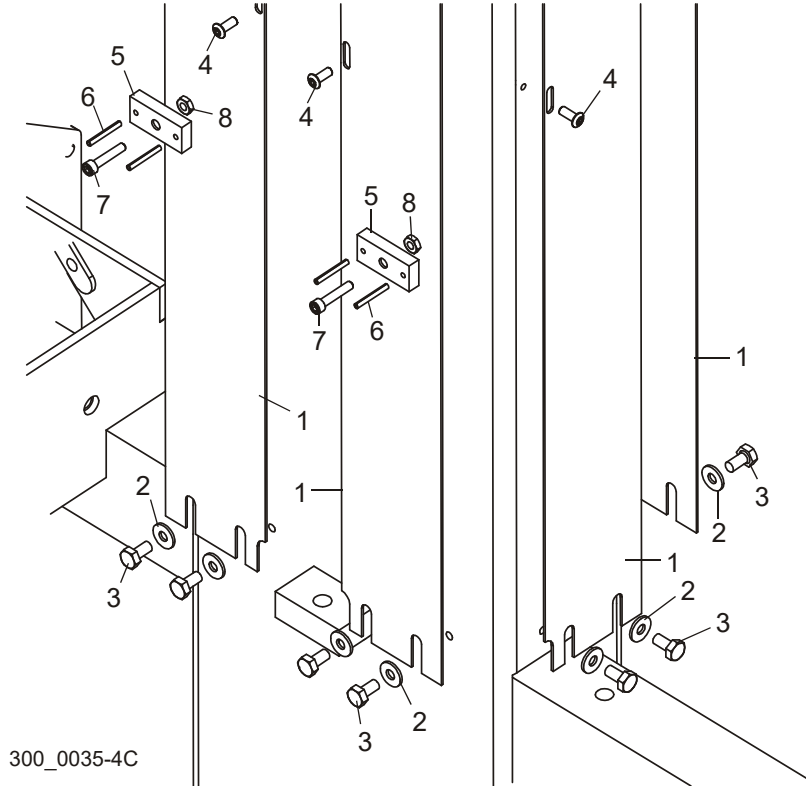

REF	DESCRIPTION (◆ Indicates Parts Available In Assemblies Only)	PART #	QTY.
	RAIL KIT, UP/DOWN BEARING	042788	1
1	Rail, Up/Down Bearing	042773	6
2	Washer, 1/4" SAE Flat	F05011-11	24
3	Bolt, 1/4-20 x 1/2" Hex Head	F05005-15	24
4	Screw, #10-24 x 1/2" Button Socket Head	F05004-35	18
5	PAD, HEAD PLASTIC	045056	2
6	PIN, 1/8" X 1" ROLL	F05012-34	4
7	BOLT, #10-24 X 1" SOCKET HEAD	F05004-2	2
8	NUT, #10-24 HEX	F05010-115	2

5.3 Up/Down Ballscrew Drive

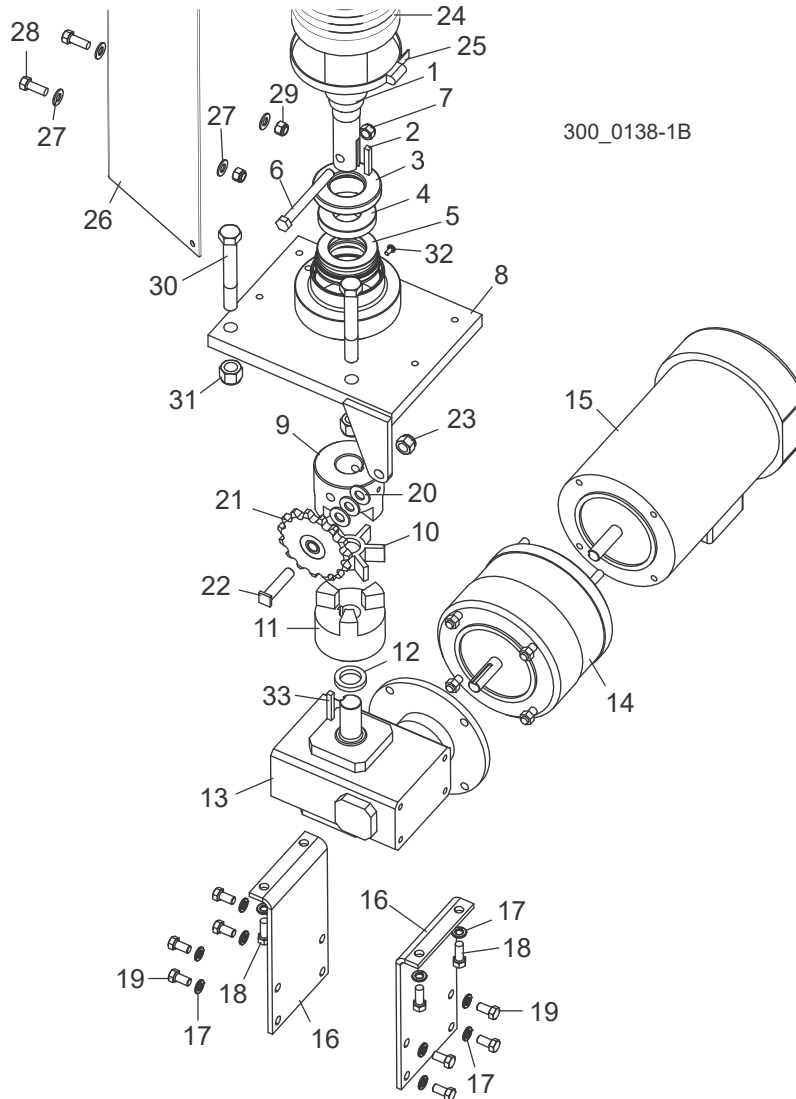

REF	DESCRIPTION (◆ Indicates Parts Available In Assemblies Only)	PART #	QTY.
	DRIVE ASSEMBLY, BALLSCREW UP/DOWN	042800	1
	Ballscrew Retrofit, Up/Down 30mm to 45mm	042901	1
	Ballscrew Assembly, Up/Down Service	036595	1
	Ballscrew Kit, Up/Down w/Nut	036596	1
1	Shaft, 2" x .5" Ballscrew	042858	1
	Nut, 2" BallScrew (Shown in Section 5.4)	042791	1
	Grease, 10cc Syringe Up/Down Ballscrew	042399	1
2	Key, 1/4" Square x 1 5/8"	042810	1
3	Seal, 1 5/8" ID Thrust Bearing	042857	1

5 Up/Down System

Up/Down Ballscrew Drive

4	Spacer, Screw/Bearing Support	042856	1	
5	Bearing Assy, 45 mm Thrust	110569	1	
	Spacer, 45 mm Thrust Bearing	110565	1	
	Bearing, 45 mm Thrust, 53209	110567	1	
	Seating Washer, 45 mm Thrust Bearing	110568	1	
6	Bolt, 7/16-14 x 4" Hex Head	F05007-180	1	
7	Nut, 7/16-14 Hex Nylon Lock	F05010-135	1	
	Middle Ballscrew Mount Parts (See Section 5.4)			
8	Bracket Weldment, Up/Down 45mm Ballscrew Mount	017790	1	
9	Coupling, Modified L110 x 1 1/4" Body	017787	1	
10	Coupling, L110 Spider	042809	1	
11	Coupling, L110 x 1" Body	042820	1	
12	Spacer, 1" ID x 1 1/2" OD x .25" Thick	042805	1	
13	Gearbox, Up/Down Ballscrew IC60	042793	1	
14	Brake, Up/Down Electric 5/8-5/8 230/460V	042281	1	
15	Motor, 2HP 3P 230/460 56C Premium Efficiency	079197	1	
16	Plate, Up/Down Gearbox Mount	042794	2	
17	Washer, 3/8" Split Lock	F05011-4	14	
18	Bolt, 3/8-16 x 1" Hex Head	F05007-7	4	
19	Bolt, 3/8-16 x 3/4" Hex Head	F05007-27	8	
20	Washer, 1/2" SAE Flat	F05011-2	3	
21	Sprocket, Idler	042367	1	
22	Shaft, Idler Sprocket	016828	1	
23	Nut, 1/2-13 Hex Nylon Lock	F05010-8	1	
24	Bellows, 5" ID x 45" Ballscrew Protective	017777	1	
25	Clamp, Bellows Worm	042419	1	
26	Guard Weldment, Up/Down Bellows	017647	1	
27	Washer, 3/8" SAE Flat	F05011-3	4	
28	Bolt, 3/8-16 x 1" Hex Head	F05007-7	2	
29	Nut, 3/8-16 Hex Nylon Lock	F05010-10	2	
30	Bolt, 5/8-11 x 4 1/2" Hex Head Grade 5	F05009-10	2	
31	Nut, 5/8-11 Hex Nylon Lock	F05010-34	2	
32	Screw, #10-24 x 3/8" Phillips Pan Head	F05004-3	1	
33	Key, 1/4" Square x 1 5/8"	042810	1	
	Oil, 8 Oz. Mobil SHC634 Bottled Synthetic Gear	L04869-4	1 ¹	
	Top Ballscrew Mount Parts (See Section 5.5)			

¹ 12 - 15 oz. required for complete oil replacement.

5.4 Ballscrew Mount (Middle)

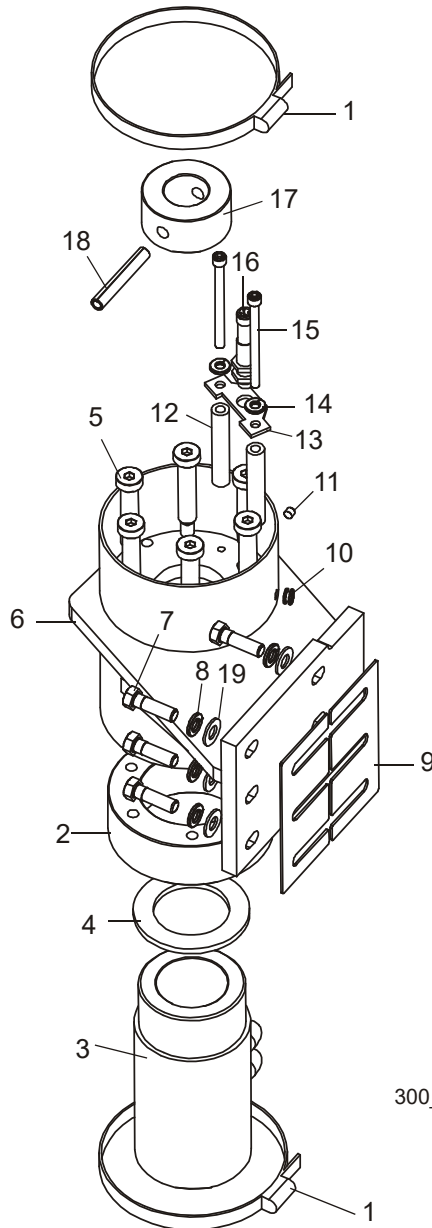

300_0062-2

REF	DESCRIPTION (◆ Indicates Parts Available In Assemblies Only)	PART #	QTY.
1	CLAMP, BALLSCREW BELLOWS	042419	2
	BALLSCREW ASSEMBLY, UP/DOWN SERVICE	036595	1
	Lower Ballscrew Mount Parts (See Section 5.3)		
2	Flange, 2" BallScrew Nut	042792	1
	Ballscrew Kit, Up/Down w/Nut	036596	1
	Shaft, 2" x .5" Ballscrew (Shown in Section 5.3)	042858	1

5 Up/Down System Ballscrew Mount (Middle)

3	Nut, 2" BallScrew	042791	1	
	Grease, 10cc Syringe Up/Down Ballscrew	042399	1	
4	Plate, BallScrew Nut Wear	042816	1	
5	Bolt, 1/2" x 2 1/4" Shoulder	F05008-136	6	
6	Bracket Weldment, Middle Ballscrew Mount	042819	1	
7	Bolt, 3/8-16 x 1 1/4" Hex Head Grade 5	F05007-123	6	
8	Washer, 3/8" Split Lock	F05011-4	6	
9	Plate, Ballscrew Mount Shim	016800	2	
10	Grommet, 9/32" Hole x 3/16" ID x 7/16" OD	042825	1	
11	Screw, 1/4-28 x 1/4" Brass Tip Socket Set	F05005-42	1	
12	Spacer, 17/64" ID x 1/2" OD x 2 3/4" Long	042821	2	
13	Plate, BallScrew Sensor Mount	042815	1	
14	Washer. 1/4" Split Lock	F05011-14	2	
15	Bolt, 1/4-20 x 3 1/4" Socket head	F05005-154	2	
16	Sensor, 12mm Unshielded Extended w/connector Proximity	025041 ¹	1	
17	Collar, Ballscrew Nut Stop	042822	1	
18	Pin, 3/8" x 2 1/2" Roll	F05012-114	1	
19	Washer, 3/8" SAE Flat	F05011-3	6	

¹ Sensor 025041 included in service kit 036595 but not Up/Down Assembly 042800 (to accommodate European structure, 4/04).

5.5 Ballscrew Mount (Top)

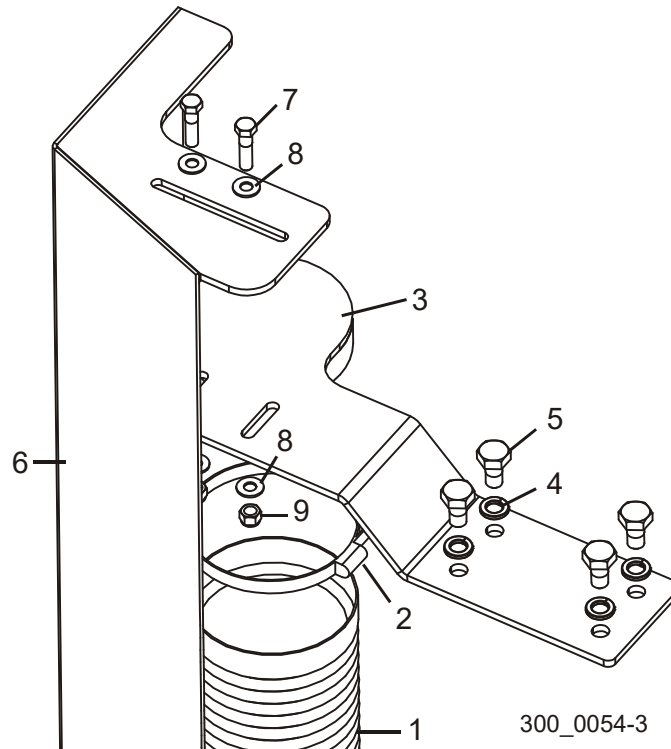

REF	DESCRIPTION (◆ Indicates Parts Available In Assemblies Only)	PART #	QTY.
1	BELLOWS, 5" ID X 62" BALLSCREW PROTECTIVE	042823	1
2	CLAMP, BALLSCREW BELLOWS	042419	1
3	MOUNT WELDMENT, TOP BELLOWS	042814	1
4	WASHER, 1/2" SPLIT LOCK	F05011-9	4
5	BOLT, 1/2-13 X 1" HEX HEAD	F05008-50	4
6	GUARD PARTS (See Section 5.3)		
7	BOLT, 3/8-16 X 1 1/2" HEX HEAD	F05007-3	2
8	WASHER, 3/8" SAE FLAT	F05011-3	4
9	NUT, 3/8-16 HEX NYLON LOCK	F05010-10	2

5.6 Transducer & Head Stop

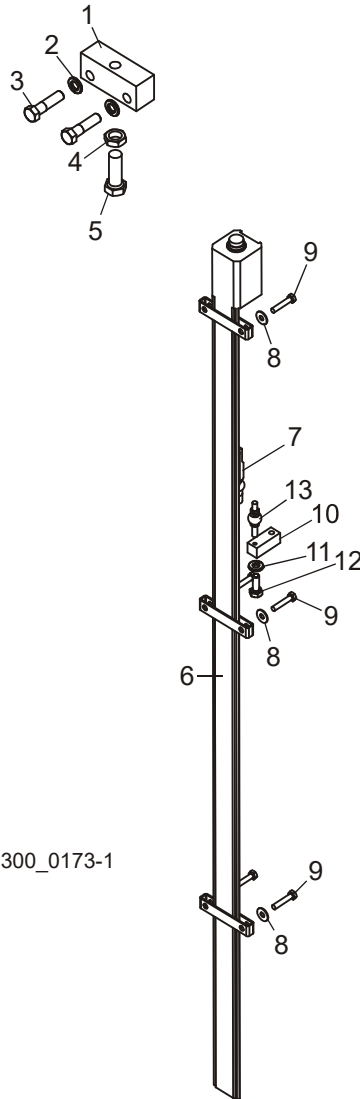

300_0173-1

REF	DESCRIPTION (◆ Indicates Parts Available In Assemblies Only)	PART #	QTY.
1	BLOCK, HEAD STOP	023886	1
2	WASHER, 3/8" SPLIT LOCK	F05011-4	5
3	BOLT, 3/8-16 X 1 1/2 HEX HEAD GRADE 5	F05007-78	5
4	NUT, 1/2-13 HEX JAM	F05010-31	1
5	BOLT, 1/2-13 X 1 1/2" HEX HEAD GRADE 5	F05008-33	1
6	SENSOR, 36" 4-20MA CAPTIVE SLIDE TRANSDUCER	025042	1
	Transducer Mounting Bracket	BAM0204	3
7	Magnet, Captive Sliding Transducer (Balluff)	052470	1
	CABLE ASSEMBLY, LT300 TRANSDUCER SENSOR	050981	1

8	WASHER, #10 SAE FLAT	F05011-18	6	
9	BOLT, #10-24 X 1" UNSLOTTED HEX HEAD	F05004-156	6	
10	BLOCK, TRANSDUCER SLIDE	042436	1	
11	WASHER, 1/4" SPLIT LOCK	F05011-14	1	
12	BOLT, 1/4-20 X 3/4" HEX HEAD FULL THREAD	F05005-1	1	
13	PIVOT, BALL JOINTED ARM	025197	1	

5.7 Up/Down Energy Chain Assembly

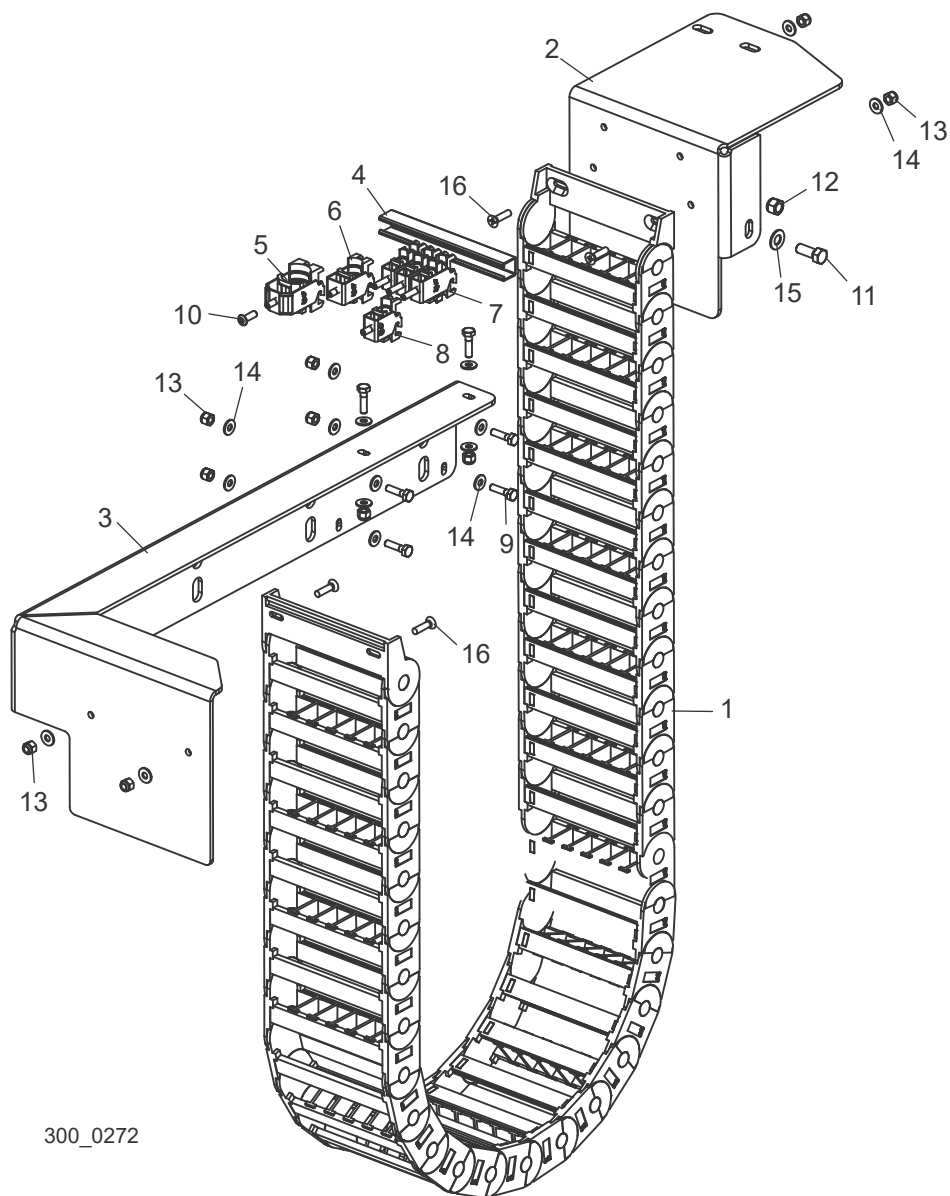

300_0272

REF	DESCRIPTION (◆ Indicates Parts Available In Assemblies Only)	PART #	QTY.
	CHAIN ASSEMBLY, UP/DOWN ENERGY (WM3500)	074154	1
1	Chain Assembly, Industrial Mill Up/down Energy	068207	1
2	Plate, Energy Chain Upper Mount	071310	1
3	Plate, Energy Chain Lower Mount	071313	1
	Relief Assembly, WM3000/3500 Strain	074148	1
4	Rail, CFX Strain Relief Profile	065979	1
5	Strain Relief, CFX 26-30mm Single Cable	074147	1

6	Strain Relief, CFX 18-20mm Single Cable	065976	1	
7	Strain Relief, CFX 6-12mm Double Cable	065977	3	
8	Strain Relief, CFX 12-14mm Single Cable	065978	1	
9	Bolt, 1/4-20 x 1" Hex Head Grade 5	F05005-101	6	
10	Screw, 1/4-20 x 3/4" SBHC	F05005-60	1	
11	Bolt, 3/8-16 x 1" Hex Head Grade 5	F05007-87	1	
12	Nut, 3/8-16 Hex Nylon Lock	F05010-10	1	
13	Nut, 1/4-20 Nylon Lock	F05010-69	12	
14	Washer, 1/4" SAE Flat	F05011-11	18	
15	Washer, 3/8" SAE Flat	F05011-3	1	
16	Bolt, 1/4-20 x 1" Flat Head	F05015-26	4	

SECTION 6 POWER FEED

6.1 Upper Track Rollers

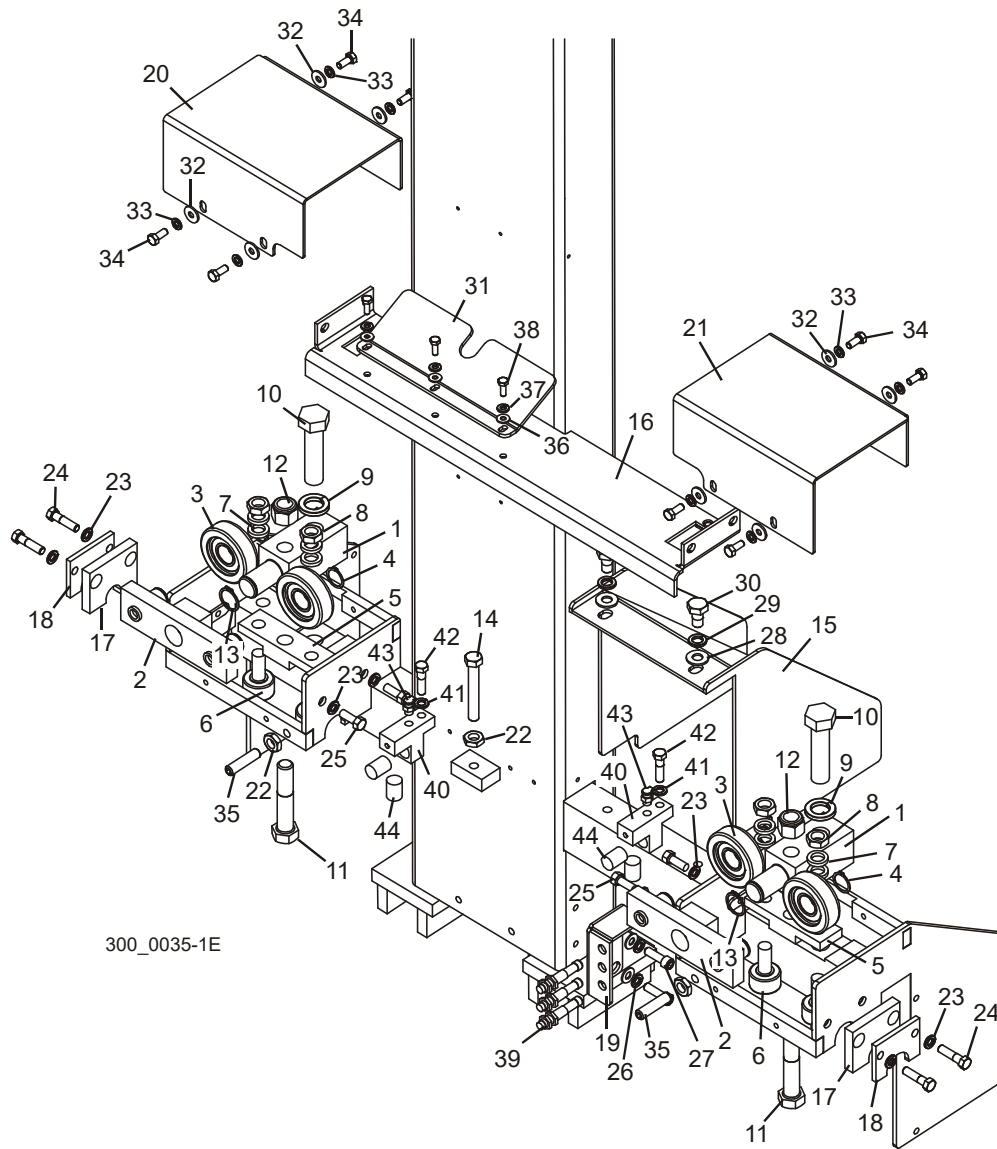

REF	DESCRIPTION (◆ Indicates Parts Available In Assemblies Only)	PART #	QTY.	
	BLOCK ASSEMBLY, UPPER TRACK ROLLER	042506	2	
1	Block, Upper Track Roller Mount	042505	1	
2	Block Assembly, Upper Roller	042507	1	
3	Bearing, MG305DDA	023857	2	
4	Ring, 1" Outside Retaining	F04254-15	2	
5	Block, Track Roller Mount	042500	1	

6	Bearing, 1 1/2" Track Roller	012797	2	
7	Spacer, 41/64" x 1" x 3/16"	S12480	4	
8	Nut, 5/8-18 Hex Jam	F05010-11	2	
9	Washer, 7/8" Split Lock	F05011-46	1	
10	Bolt, 7/8-14 x 3 1/2" Hex Head Grade 5	F05014-1	1	
11	Bolt, 3/4-10 x 4" Hex Head Grade 5	F05013-3	1	
12	Nut, 3/4-10 Hex Nylon Lock	F05010-103	1	
13	Ring, 1 1/8" External Retaining Ring	F04254-36	1	
14	BOLT, 1/2-13 X 3 1/2" HEX HEAD FULL THREAD	F05008-11	1	
15	RAMP WELDMENT, SAWDUST	042379	1	
16	COVER WELDMENT, UPPER TRACK ROLLER CENTER	042391	1	
17	PAD, PLASTIC WIPER	045175	2	
18	PLATE, WIPER PAD	045176	2	
19	BRACKET, PROXIMITY SENSOR MOUNT	042112	1	
20	COVER, RIGHT UPPER TRACK ROLLER	042394	1	
21	COVER, LEFT UPPER TRACK ROLLER	042368	1	
22	NUT, 1/2-13 HEX JAM	F05010-31	3	
23	WASHER, 3/8" SPLIT LOCK	F05011-4	10	
24	BOLT, 3/8-16 X 1 1/2" HEX HEAD	F05007-3	4	
25	BOLT, 3/8-16 X 1" HEX HEAD	F05007-7	4	
26	WASHER, 3/8" SAE FLAT	F05011-3	2	
27	BOLT, 3/8-16 X 1 1/4" SOCKET HEAD	F05007-150	2	
28	WASHER, 1/2" SAE FLAT	F05011-2	2	
29	WASHER, 1/2" SPLIT LOCK	F05011-9	2	
30	BOLT, 1/2-13 X 1" HEX HEAD	F05008-50	2	
31	PLATE, SAWDUST RAMP	016801	1	
32	WASHER, 5/16" STANDARD FLAT	F05011-16	8	
33	WASHER, 5/16" SPLIT LOCK	F05011-13	8	
34	BOLT, 5/16-18 X 3/4" HEX HEAD	F05006-5	8	
35	SCREW, 1/2-13 X 2" FLAT POINT SOCKET SET	F05008-130	2	
36	WASHER, 1/4" SAE FLAT	F05011-11	3	
37	WASHER, 1/4" SPLIT LOCK	F05011-14	3	
38	BOLT, 1/4-20 X 3/4" HEX HEAD	F05005-129	3	
39	SENSOR, 12MM PROXIMITY	025041	3	
40	BLOCK, UPPER TRACK OILER	045045	2	
41	WASHER, 3/8" SPLIT LOCK	F05011-4	2	
42	BOLT, 3/8-16 X 1 1/2" HEX HEAD	F05007-3	2	
43	FITTING, 1/8" NPT OIL W/COVER	036333	2	
44	PAD, ROUND FELT WIPER	033375	4	

6.2 Lower Track Rollers

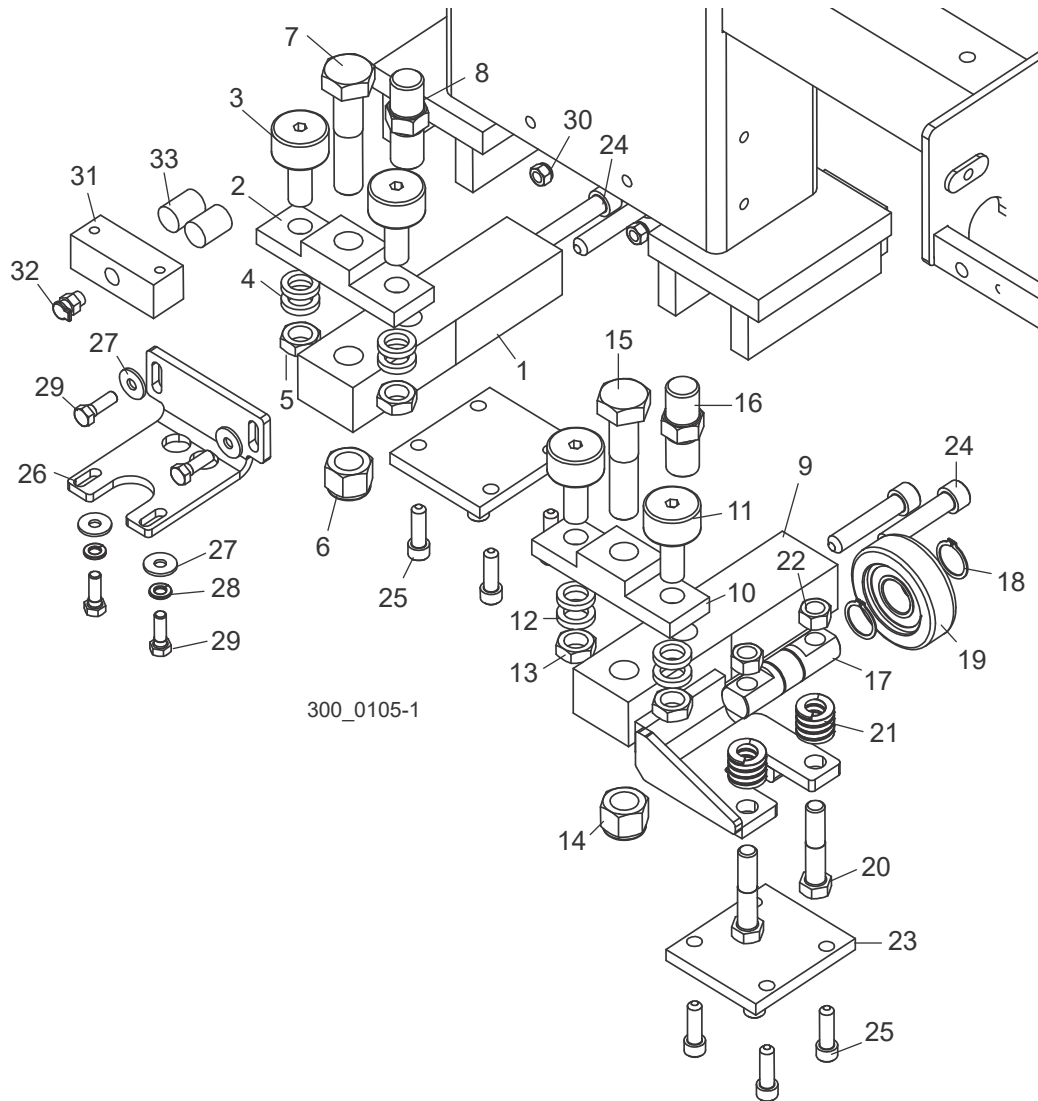

REF	DESCRIPTION (◆ Indicates Parts Available In Assemblies Only)	PART #	QTY.
	BLOCK ASSEMBLY, LOWER TRACK ROLLER	036345	1
1	Block Weldment, Lower Track Roller Mount	036326	1
2	Block, Track Roller Mount	042500	1
3	Bearing, 1 1/2" Track Roller	012797	2
4	Spacer, 41/64" x 1" x 3/16"	S12480	4
5	Nut, 5/8-18 Hex Jam	F05010-11	2
6	Nut, 3/4-10 Hex Nylon Lock	F05010-103	1
7	Bolt, 3/4-10 x 3 1/2" Hex Head	F05009-54	1
8	Pin, Head Safety Lock (Threaded)	036324	1

	BLOCK ASSEMBLY, LOWER TRACK ROLLER W/BOTTOM ROLLER	036701	1	
9	Block Weldment, Lower Track Roller Mount w/Bottom Roller	036700	1	
10	Block, Track Roller Mount	042500	1	
11	Bearing, 1 1/2" Track Roller	012797	2	
12	Spacer, 41/64" x 1" x 3/16"	S12480	4	
13	Nut, 5/8-18 Hex Jam	F05010-11	2	
14	Nut, 3/4-10 Hex Nylon Lock	F05010-103	1	
15	Bolt, 3/4-10 x 3 1/2" Hex Head	F05009-54	1	
16	Pin, Head Safety Lock (Threaded)	036324	1	
17	Shaft, Bottom Roller Mount	023858	1	
18	Ring, 1" Outside Retaining	F04254-15	2	
19	Bearing, MG305DDA	023857	1	
20	Bolt, 1/2-13 x 2 1/2" Hex Head Grade 5	F05008-74	2	
21	Spring, 1/2" ID x 1" OD x 1" Die	036713	2	
22	Nut, 1/2-13 Hex Lock	F05010-3	2	
23	PLATE, LOWER ROLLER RETAINER	045158	2	
24	BOLT, 1/2-20 X 2 1/2" SOCKET HEAD	F05008-45	4	
25	BOLT, 3/8-16 X 1 1/4" SOCKET HEAD	F05007-150	8	
26	PLATE, LOWER TRACK OILER MOUNT	042415	1	
27	WASHER, 5/16" STANDARD FLAT	F05011-16	4	
28	WASHER, 5/16" SPLIT LOCK	F05011-13	2	
29	BOLT, 5/16-18 X 1" HEX HEAD	F05006-1	4	
30	NUT, 5/16-18 HEX NYLON LOCK	F05010-58	2	
31	BLOCK, LOWER TRACK OILER	036334	1	
32	FITTING, 1/8" NPT OIL W/COVER	036333	1	
33	PAD, ROUND FELT WIPER	033375	2	

6.3 Power Feed Drive

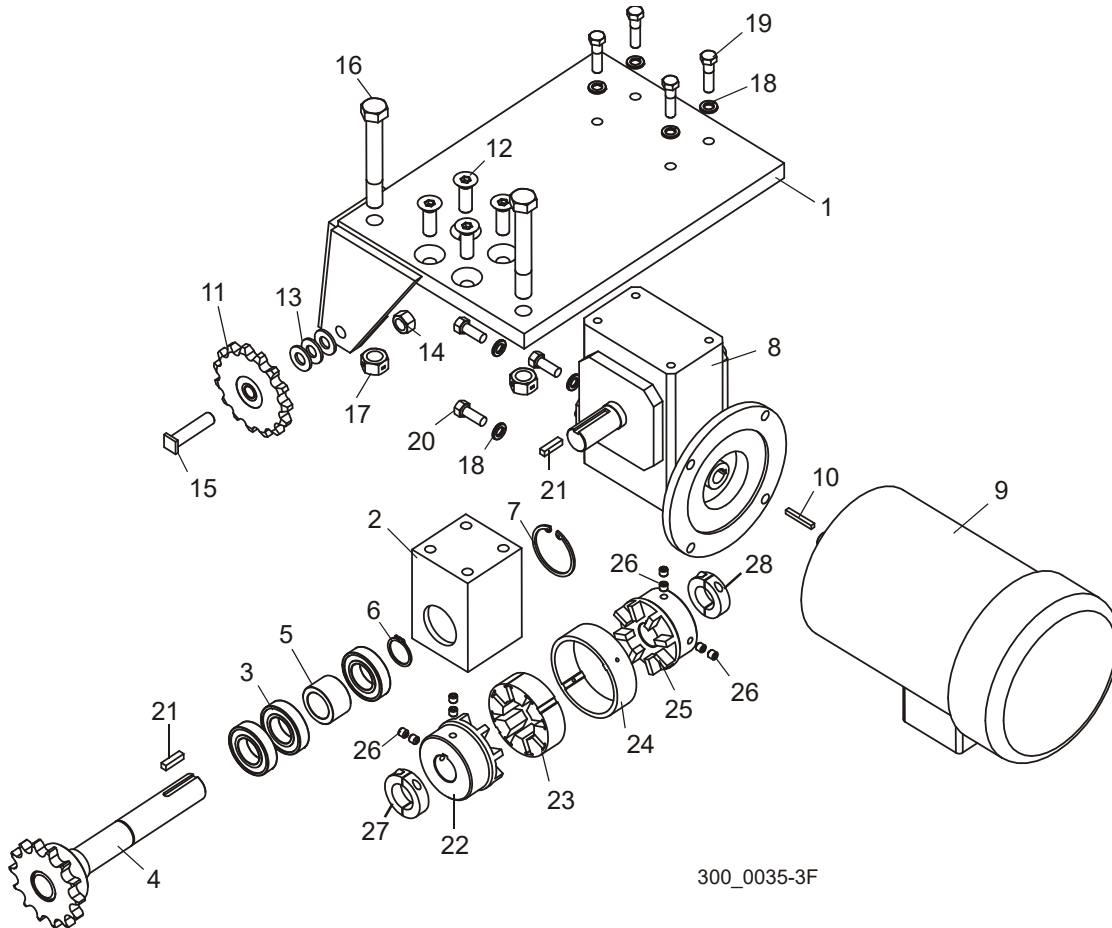

REF	DESCRIPTION (◆ Indicates Parts Available In Assemblies Only)	PART #	QTY.
	DRIVE ASSEMBLY, POWER FEED	042382	1
1	Bracket Weldment, Power Feed Drive Mount	042384	1
	Shaft Assembly, Power Feed Drive	042383	1
2	Block, Power Feed Drive Shaft Bearing	042381	1
3	Bearing, R18	066798	3
4	Shaft Weldment, Power Feed Drive	042365	1
5	Spacer, Power Feed Bearing	042387	1
6	Ring, 1 1/8" Outside Retaining	F04254-36	1
7	Ring, 2 1/8" Inside Retaining	F04254-38	1
8	Gearbox, WM3500 P/F IUC60-7.5:1-L-140TC	079195	1
9	Motor, 2HP 3P 230/460 145TC Premium Efficiency	079196	1
10	Key, 3/16" Square x 1 3/4" Long	074129	1
11	Sprocket, 6015 x 1/2" Idler	042367	1
12	Screw, 1/2-13 x 1 1/2" Flat Socket Head	F05008-80	4

13	Washer, 1/2" SAE Flat	F05011-2	3	
14	Nut, 1/2-13 Hex Lock	F05010-3	1	
15	Shaft, Power Feed Idler Sprocket	016828	1	
16	Bolt, 5/8-11 x 4 1/2" Hex Head Grade 5	F05009-10	2	
17	Nut, 5/8-11 Hex Lock	F05010-4	2	
18	Washer, 3/8" Split Lock	F05011-4	8	
19	Bolt, 3/8-16 x 1 1/2" Hex Head	F05007-3	4	
20	Bolt, 3/8-16 x 1" Hex Head	F05007-7	4	
21	Key, 1/4" x 1"	S21486	2	
	Coupling, Power Feed Shaft	042655	1	
22	Coupling Body, 10R x 1 1/8"	042655-4	1	
23	Coupling Spider, 10R Urethane	042655-2	1	
24	Coupling Ring, 10R Steel	042655-5	1	
25	Coupling Body, 10R x 1"	042655-1	1	
26	Screw, M8-1.25 x 8mm Socket Head Set	F05004-234	8	
27	Collar, 1 1/8" Shaft Clamp-On	038445	1	
28	Collar, 1" Shaft Clamp-On	038444	1	
	Oil, 8 Oz. Mobil SHC634 Bottled Synthetic Gear	L04869-4	1 ¹	

¹ 19 - 22 oz. required for complete oil replacement.

6.4 Feed Chain & Stops

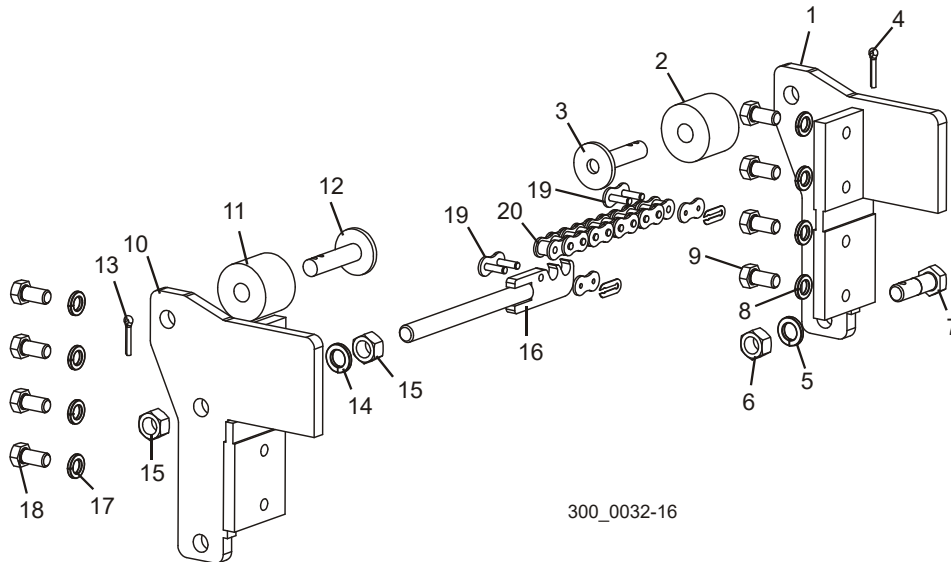

REF	DESCRIPTION (◆ Indicates Parts Available In Assemblies Only)	PART #	QTY.
	STOP ASSEMBLY, FRONT SAW HEAD	035646	1
1	Bracket Weldment, Front Saw Head Stop	042408	1
2	Bushing, 11/16" x 2 1/8" x 1 3/4" Rubber	P12165	1
3	Pin Weldment, Head Stop	W09293	1
4	Pin, 3/16" x 1" Cotter	F05012-21	1
5	Washer, 5/8" Split Lock	F05011-27	1
6	Nut, 5/8-18 Hex	F05010-50	1
7	Bolt, #60 Feed Chain Tensioner	035653	1
8	Washer, 1/2" Split Lock	F05011-9	4
9	Bolt, 1/2-13 x 1 Hex Head Grade 8	F05008-128	4
	STOP ASSEMBLY, REAR HEAD	036199	1
10	Stop Weldment, Right	042411	1
11	Bushing, 11/16" x 2 1/8" x 1 3/4" Rubber	P12165	1
12	Pin Weldment, Head Stop	W09293	1
13	Pin, 3/16" x 1" Cotter	F05012-21	1
14	Washer, 5/8" Split Lock	F05011-27	1
15	Nut, 5/8-18 Hex	F05010-50	2
16	Rod Weldment, #60 Feed Chain Tensioner	035652	1
17	Washer, 1/2" Split Lock	F05011-9	4
18	Bolt, 1/2-13 x 1 Hex Head Grade 8	F05008-128	4
19	Link, #60 Master	042398	2
20	Chain, #60 x 27' Power Feed	036200	1

6.5 Lower Wireway

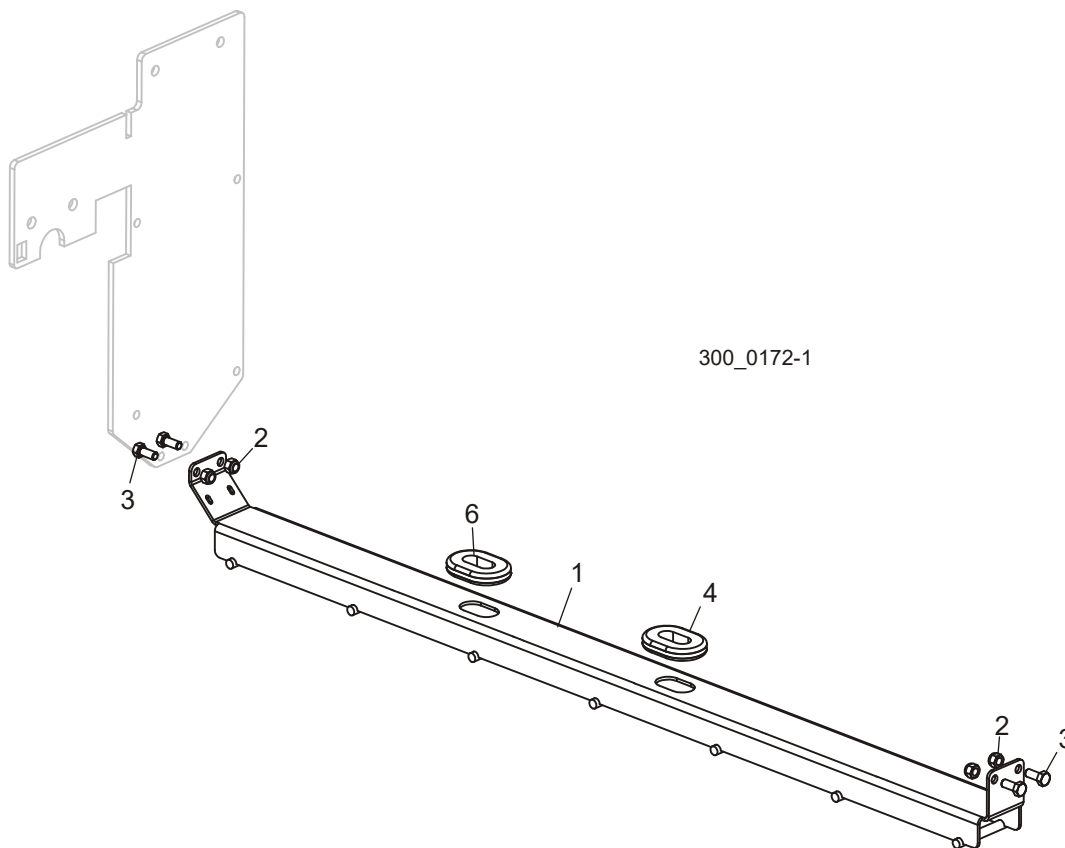

REF	DESCRIPTION (◆ Indicates Parts Available In Assemblies Only)	PART #	QTY.
1	CABLE CARRIER, LOWER	036341	1
2	NUT, 5/16-18 HEX NYLON LOCK	F05010-58	4
3	BOLT, 5/16-18 X 3/4" HEX HEAD	F05006-5	4
4	GROMMET, 1" X 1 3/4" OVAL RUBBER	085613	2

7 Bed Frame
Bed Rail #1 (Front)

SECTION 7 BED FRAME

7.1 Bed Rail #1 (Front)

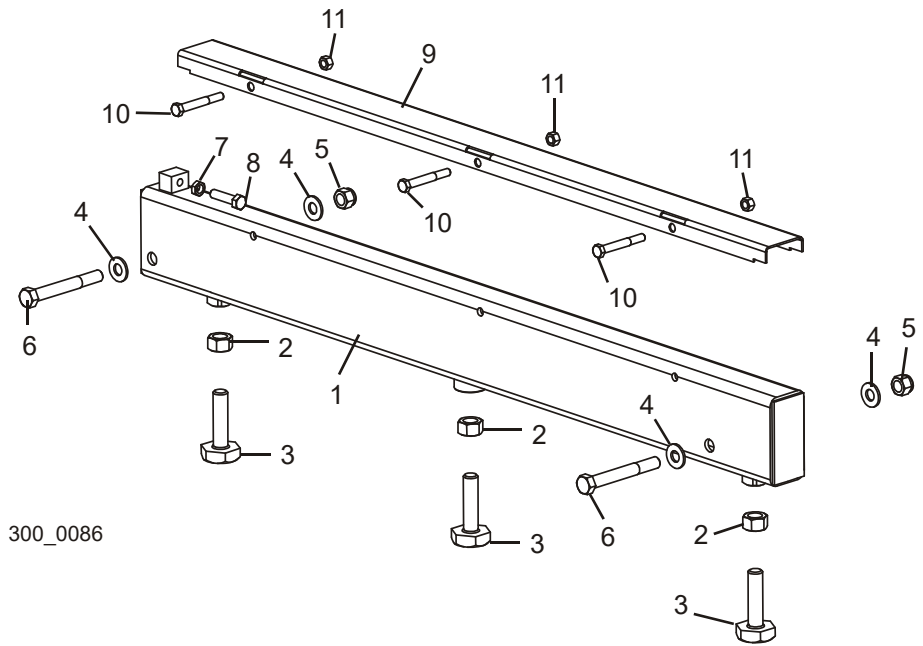

REF	DESCRIPTION (◆ Indicates Parts Available In Assemblies Only)	PART #	QTY.
	RAIL ASSEMBLY, #1 BED (FRONT)	036410	1
1	Rail Weldment, #1 Bed	036411	1
2	Nut, 5/8-11 Hex	F05010-5	3
3	Bolt, Bed Rail Adjustment	S13006	3
4	Washer, 1/2" SAE Flat	F05011-2	4
5	Nut, 1/2-13 Nylon Lock	F05010-8	2
6	Bolt, 1/2-13 x 4" Hex Head	F05008-26	2
7	Nut, 3/8-16 Hex Jam	F05010-29	1
8	Bolt, 3/8-16 x 1 1/2" Hex Head Full Thread	F05007-17	1
	Cover Kit, Front/Rear Bed Rail SS	079144	1
9	Cover, Stainless Steel Bed Rail	016898	1
10	Bolt, 5/16-18 x 2 1/2" Hex Head	F05006-10	3
11	Nut, 5/16-18 Hex Lock	F05010-6	3

7.2 Bed Rail #2 (Middle Front)

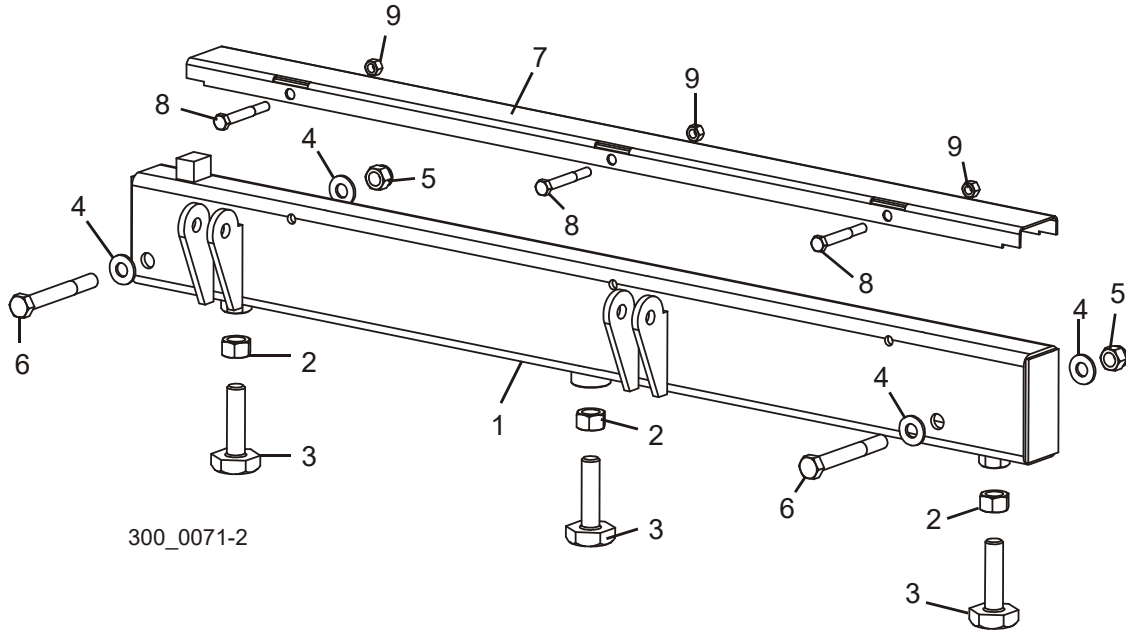

REF	DESCRIPTION (◆ Indicates Parts Available In Assemblies Only)	PART #	QTY.
	RAIL ASSEMBLY, #2 BED (MIDDLE FRONT)	035635	1
1	Rail Weldment, #2 Bed	035631	1
2	Nut, 5/8-11 Hex	F05010-5	3
3	Bolt, Bed Rail Adjustment	S13006	3
4	Washer, 1/2" SAE Flat	F05011-2	4
5	Nut, 1/2-13 Nylon Lock	F05010-8	2
6	Bolt, 1/2-13 x 4" Hex Head	F05008-26	2
7	Cover, Stainless Steel Bed Rail	016898	1
8	Bolt, 5/16-18 x 2 1/2" Hex Head	F05006-10	3
9	Nut, 5/16-18 Hex Lock	F05010-6	3

7 Bed Frame

Bed Rail (Middle)

7.3 Bed Rail (Middle)

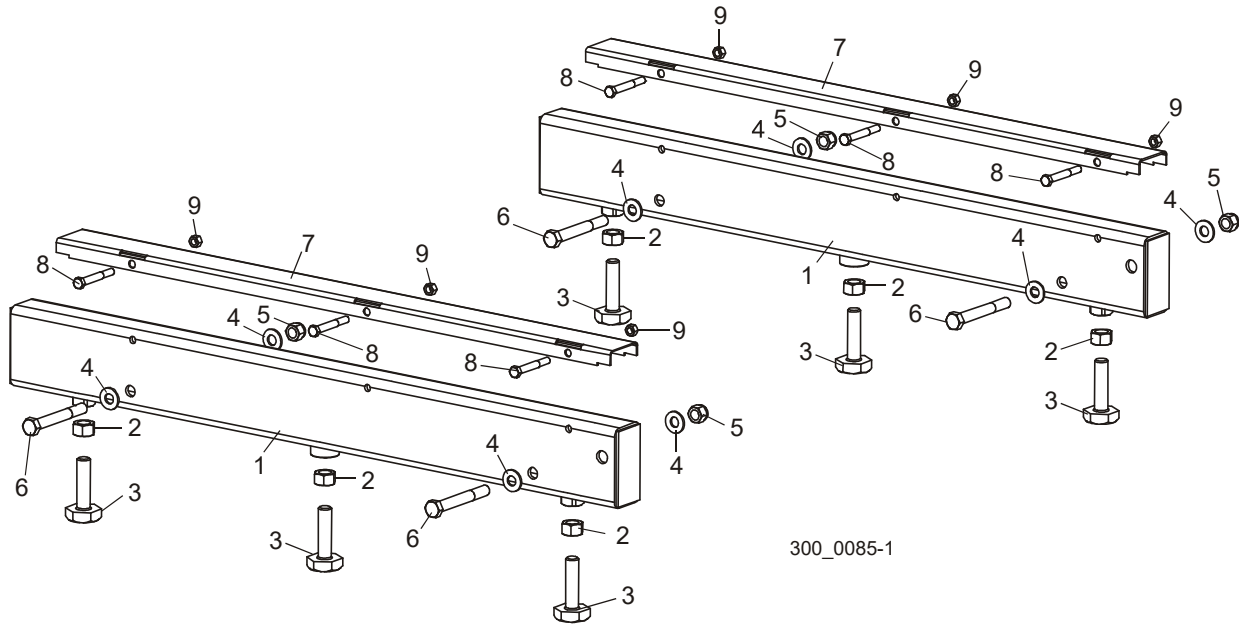

REF	DESCRIPTION (◆ Indicates Parts Available In Assemblies Only)	PART #	QTY.
	RAIL ASSEMBLY, MIDDLE BED	035639	2
1	Rail Weldment, Middle Bed	035638	1
2	Nut, 5/8-11 Hex	F05010-5	3
3	Bolt, Bed Rail Adjustment	S13006	3
4	Washer, 1/2" SAE Flat	F05011-2	4
5	Nut, 1/2-13 Nylon Lock	F05010-8	2
6	Bolt, 1/2-13 x 4" Hex Head	F05008-26	2
7	Cover, Stainless Steel Bed Rail	S09944	1
8	Bolt, 5/16-18 x 2 1/2" Hex Head	F05006-10	3
9	Nut, 5/16-18 Hex Lock	F05010-6	3

7.4 Bed Rail #4 (Middle Rear)

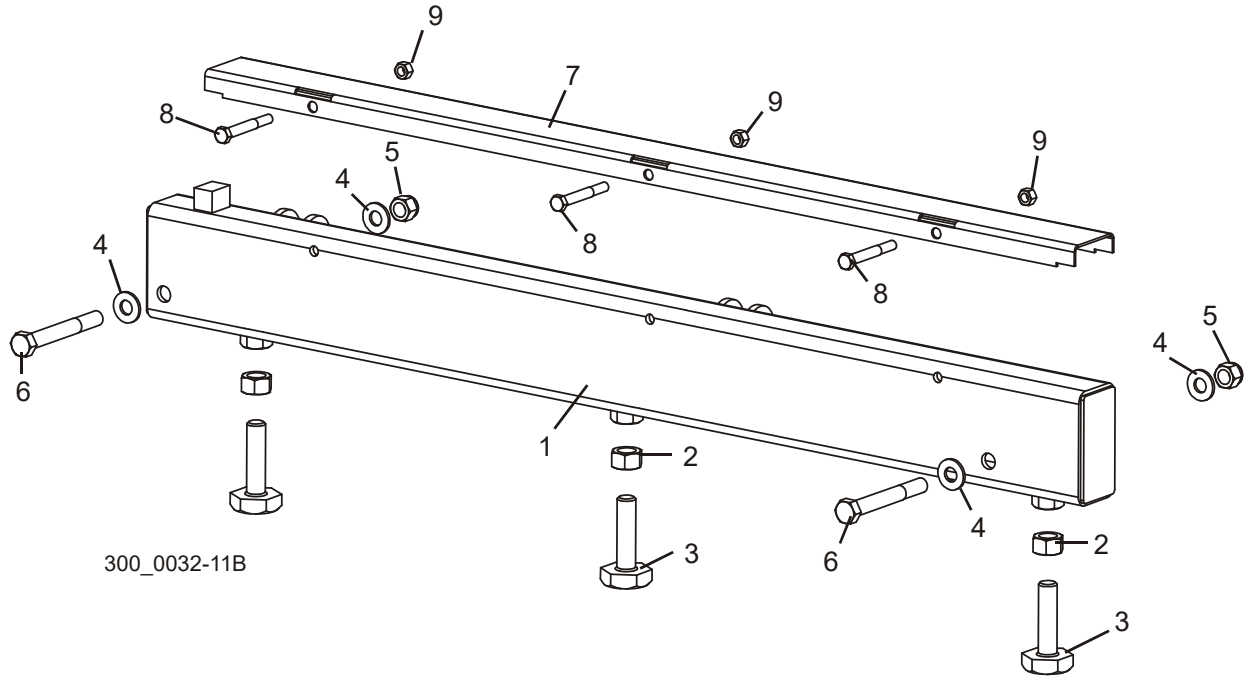

REF	DESCRIPTION (◆ Indicates Parts Available In Assemblies Only)	PART #	QTY.
	RAIL ASSEMBLY, #4 BED (MIDDLE REAR)	035636	1
1	Rail Weldment, #4 Bed	035632	1
2	Nut, 5/8-11 Hex	F05010-5	3
3	Bolt, Bed Rail Adjustment	S13006	3
4	Washer, 1/2" SAE Flat	F05011-2	4
5	Nut, 1/2-13 Nylon Lock	F05010-8	2
6	Bolt, 1/2-13 x 4" Hex Head	F05008-26	2
7	Cover, Stainless Steel Bed Rail	016898	1
8	Bolt, 5/16-18 x 2 1/2" Hex Head	F05006-10	3
9	Nut, 5/16-18 Hex Lock	F05010-6	3

7 Bed Frame

Bed Rail #5 (Rear)

7.5 Bed Rail #5 (Rear)

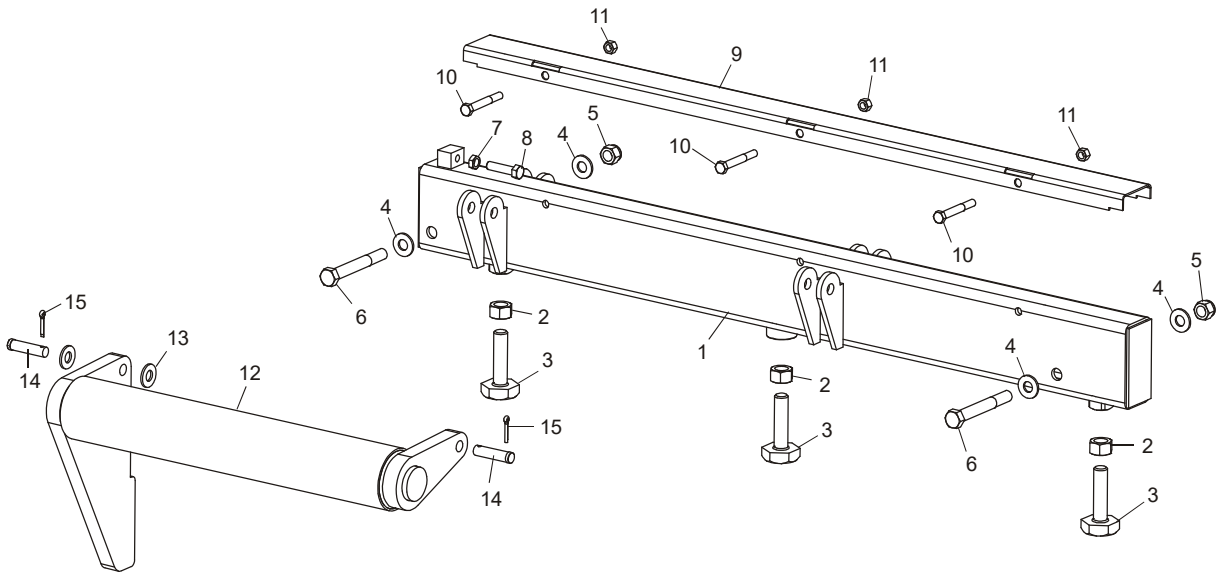

300_0088-1

REF	DESCRIPTION (◆ Indicates Parts Available In Assemblies Only)	PART #	QTY.
	RAIL ASSEMBLY, #5 BED (REAR)	035637	1
1	Rail Weldment, #5 Bed	035633	1
2	Nut, 5/8-11 Hex	F05010-5	3
3	Bolt, Bed Rail Adjustment	S13006	3
4	Washer, 1/2" SAE Flat	F05011-2	4
5	Nut, 1/2-13 Nylon Lock	F05010-8	2
6	Bolt, 1/2-13 x 4" Hex Head	F05008-26	2
7	Nut, 3/8-16 Hex Jam	F05010-29	1
8	Bolt, 3/8-16 x 1 1/2" Hex Head Full Thread	F05007-17	1
9	Cover, Stainless Steel Bed Rail	016898	1
10	Bolt, 5/16-18 x 2 1/2" Hex Head	F05006-10	3
11	Nut, 5/16-18 Hex Lock	F05010-6	3
	ROLLER ASSEMBLY, REAR BOARD	036414	1
12	Roller Assembly, Toe Board	074852	1
13	Washer, 1/2" SAE Flat	F05011-2	2
14	Pin, 1/2" x 1 3/4" Clevis	F05012-82	2
15	Pin, 1/8" x 3/4" Cotter	F05012-3	2

7.6 Leg Assembly (Front & Rear)

WM3500 (with Pantograph Cable Boom)

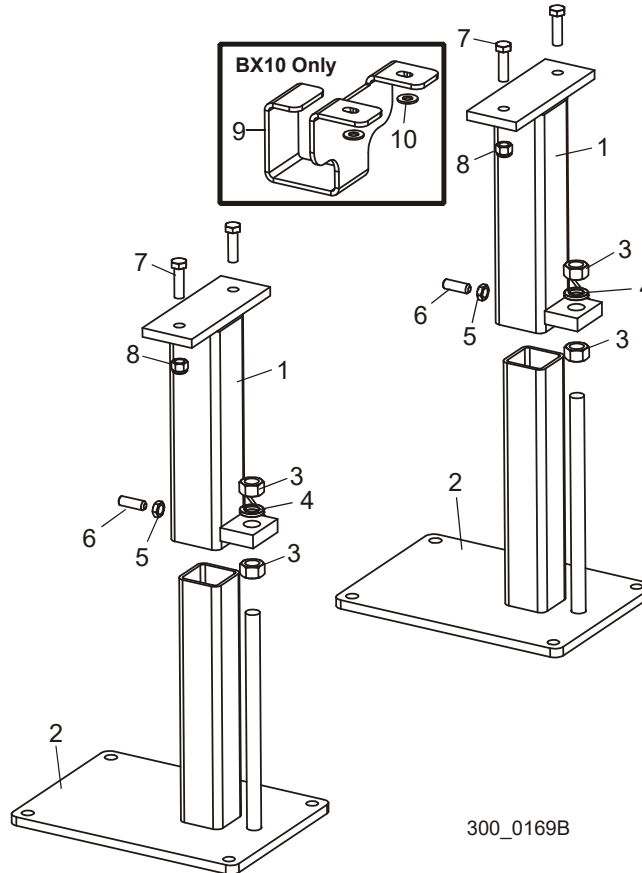

REF	DESCRIPTION (◆ Indicates Parts Available In Assemblies Only)	PART #	QTY.
	LEG ASSEMBLY, FRONT/REAR	006785	2
1	Leg Weldment, Front/Rear	006786	1
2	Plate Weldment, 10" x 13 3/4" Foot	006791	1
3	Nut, 3/4-16 Hex	F05010-92	2
4	Washer, 3/4" Split Lock	F05011-6	1
5	Nut, 1/2-13 Hex Jam	F05010-31	1
6	Screw, 1/2-13 x 1 1/2" Socket Head Flat Point Set	F05008-31	1
7	Bolt, 1/2-13 x 1 3/4" Hex Head Grade 5	F05008-88	2
8	Nut, 1/2-13 Hex Nylon Lock	F05010-8	2
9	BRACKET, BX10 HYDRAULIC HOSE HANGER	008750	1
10	WASHER, 1/2" SAE FLAT	F05011-2	2

7 Bed Frame

Leg Assembly (Front & Rear)

7.7 Leg Assembly (Front & Rear)

WM3500 (without Pantograph Cable Boom)

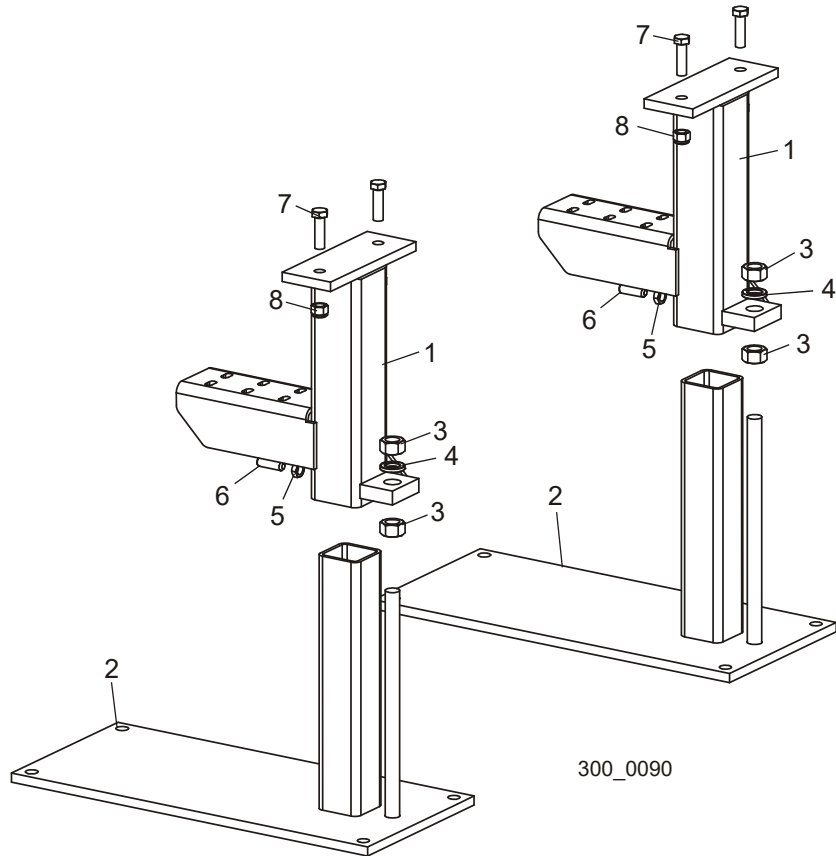

REF	DESCRIPTION (◆ Indicates Parts Available In Assemblies Only)	PART #	QTY.
	LEG ASSEMBLY, FRONT/REAR	036453 ¹	2
1	Leg Weldment, Front/Rear	036454	1
2	Plate Weldment, Front/Rear Leg Foot	051355	1
3	Nut, 3/4-16 Hex	F05010-92	2
4	Washer, 3/4" Split Lock	F05011-6	1
5	Nut, 1/2-13 Hex Jam	F05010-31	1
6	Screw, 1/2-13 x 1 1/2" Socket Head Flat Point Set	F05008-31	1
7	Bolt, 1/2-13 x 1 3/4" Hex Head Grade 5	F05008-88	2
8	Nut, 1/2-13 Hex Nylon Lock	F05010-8	2

¹ Legs with cable carrier supports and longer foot plates supplied in kit 006806 instead of Pantograph for customers with space constraints.

7.8 Leg Assembly (#2 & #5)

WM3500 (with Pantograph Cable Boom)

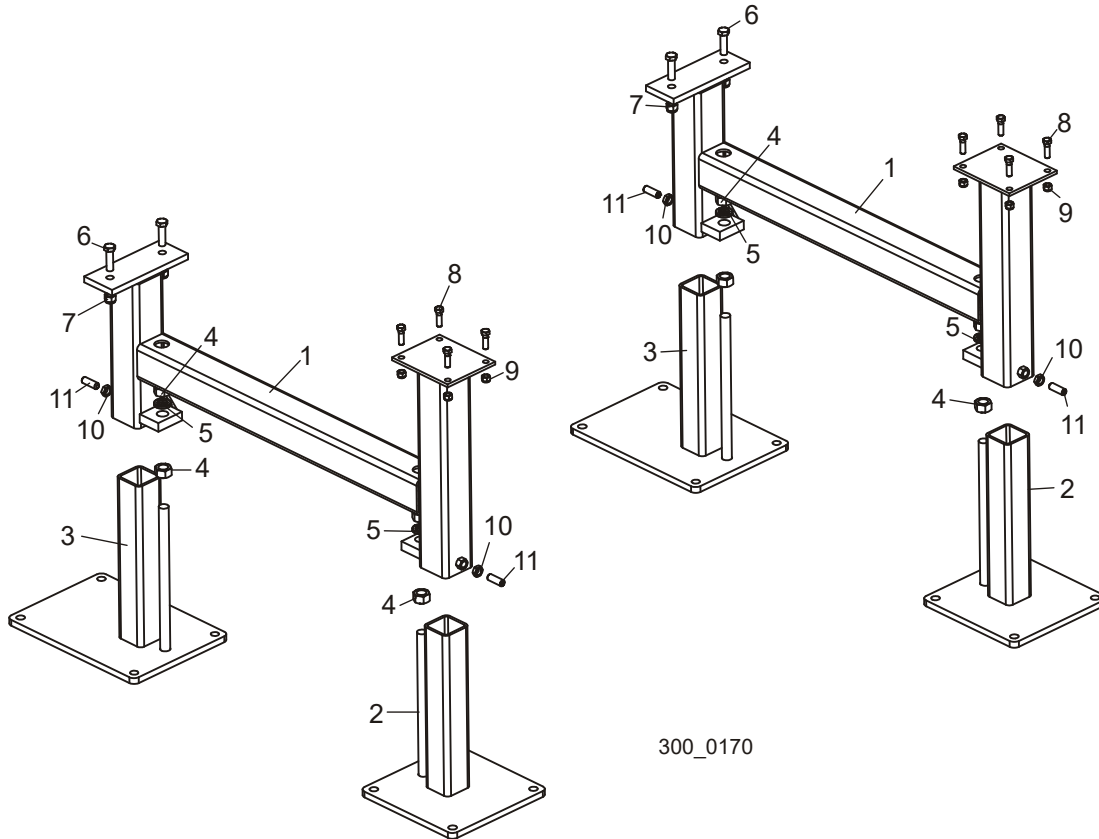

REF	DESCRIPTION (◆ Indicates Parts Available In Assemblies Only)	PART #	QTY.
	LEG ASSEMBLY, #2 & #5	006787	2
1	Leg Weldment, Tall	006788	1
2	Plate Weldment, 10" x 10" Foot	051363	1
3	Plate Weldment, 10" x 13 3/4" Foot	006791	1
4	Nut, 3/4-16 Hex	F05010-92	4
5	Washer, 3/4" Split Lock	F05011-6	2
6	Bolt, 1/2-13 x 1 3/4" Hex Head Grade 5	F05008-88	2
7	Nut, 1/2-13 Hex Nylon Lock	F05010-8	2
8	Bolt, 3/8-16 x 1 1/4" Hex Head Grade 5	F05007-123	4
9	Nut, 3/8-16 Hex Nylon Lock	F05010-10	4
10	Nut, 1/2-13 Hex Jam	F05010-31	2
11	Screw, 1/2-13 x 1 1/2" Socket Head Flat Point Set	F05008-31	2

7 Bed Frame

Leg Assembly (#2 & #5)

7.9 Leg Assembly (#2 & #5)

WM3500 (without Pantograph Cable Boom)

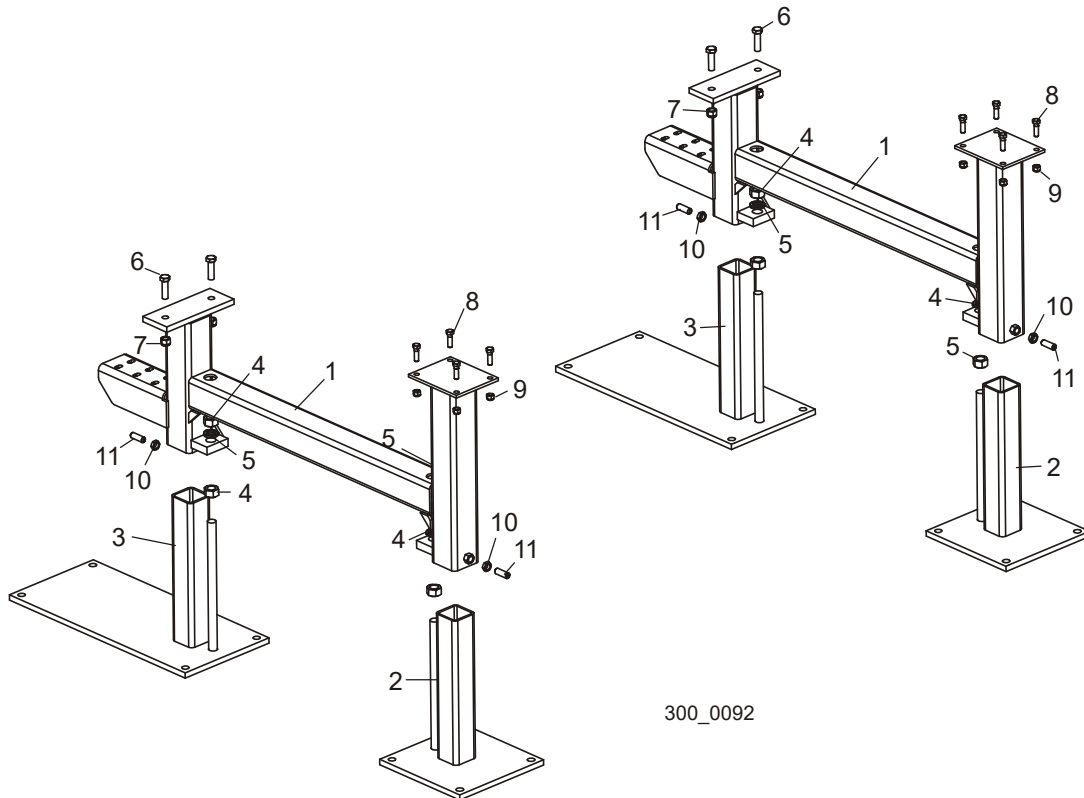

REF	DESCRIPTION (◆ Indicates Parts Available In Assemblies Only)	PART #	QTY.
	LEG ASSEMBLY, #2 & #5	036456 ¹	2
1	Leg Weldment, Tall	036457	1
2	Plate Weldment, 10" x 10" Foot	051363	1
3	Plate Weldment, 10" x 22" Foot	051355	1
4	Nut, 3/4-16 Hex	F05010-92	4
5	Washer, 3/4" Split Lock	F05011-6	2
6	Bolt, 1/2-13 x 1 3/4" Hex Head Grade 5	F05008-88	2
7	Nut, 1/2-13 Hex Nylon Lock	F05010-8	2
8	Bolt, 3/8-16 x 1 1/4" Hex Head Grade 5	F05007-123	4
9	Nut, 3/8-16 Hex Nylon Lock	F05010-10	4
10	Nut, 1/2-13 Hex Jam	F05010-31	2
11	Screw, 1/2-13 x 1 1/2" Socket Head Flat Point Set	F05008-31	2

¹ Legs with cable carrier supports and longer foot plates supplied in kit 006806 instead of Pantograph for customers with space constraints.

7.10 Leg Assembly (#3 & #4)

WM3500 (with Pantograph Cable Boom)

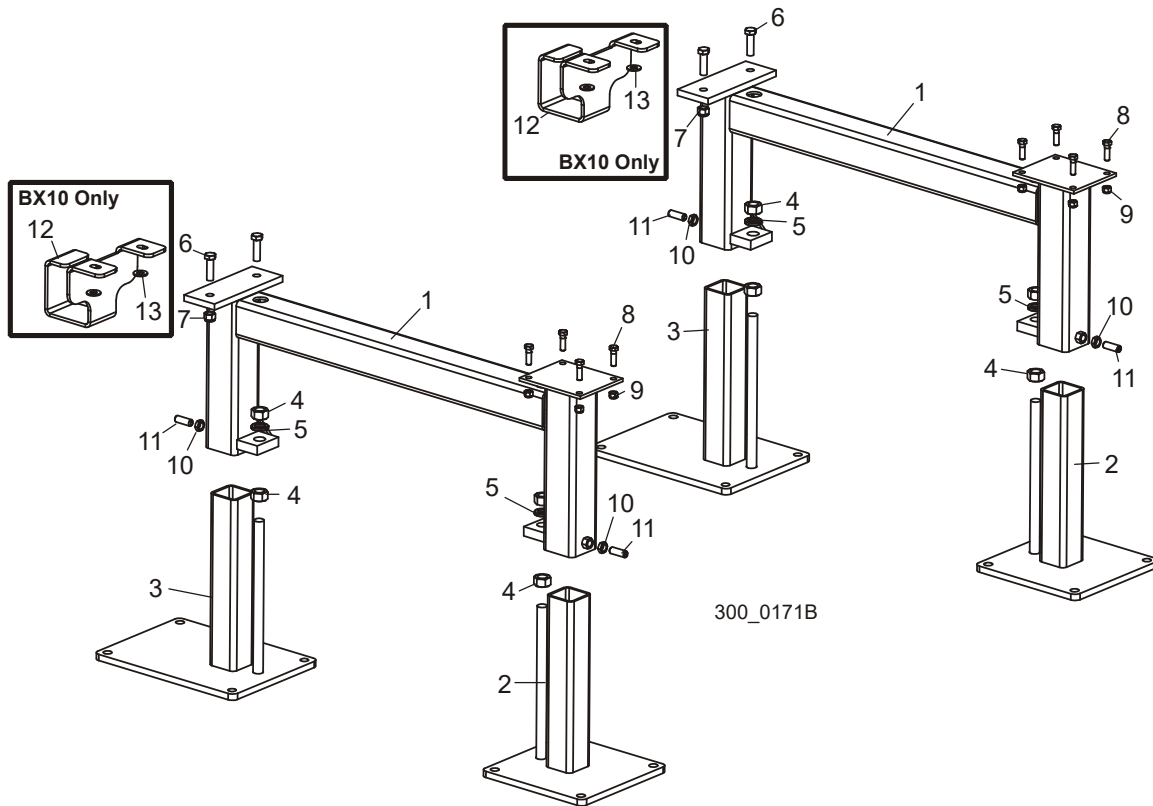

REF	DESCRIPTION (◆ Indicates Parts Available In Assemblies Only)	PART #	QTY.
	LEG ASSEMBLY, #3 & #4	006789	2
1	Leg Weldment, Short	006790	1
2	Plate Weldment, 10" x 10" Foot	051363	1
3	Plate Weldment, 10" x 13 3/4" Foot	006791	1
4	Nut, 3/4-16 Hex	F05010-92	4
5	Washer, 3/4" Split Lock	F05011-6	2
6	Bolt, 1/2-13 x 1 3/4" Hex Head Grade 5	F05008-88	2
7	Nut, 1/2-13 Hex Nylon Lock	F05010-8	2
8	Bolt, 3/8-16 x 1 1/4" Hex Head Grade 5	F05007-123	4
9	Nut, 3/8-16 Hex Nylon Lock	F05010-10	4
10	Nut, 1/2-13 Hex Jam	F05010-31	2
11	Screw, 1/2-13 x 1 1/2" Socket Head Flat Point Set	F05008-31	2
12	BRACKET, BX10 HYDRAULIC HOSE HANGER	008750	2
13	WASHER, 1/2" SAE FLAT	F05011-2	4

7 Bed Frame

Leg Assembly (#3 & #4)

7.11 Leg Assembly (#3 & #4)

WM3500 (without Pantograph Cable Boom)

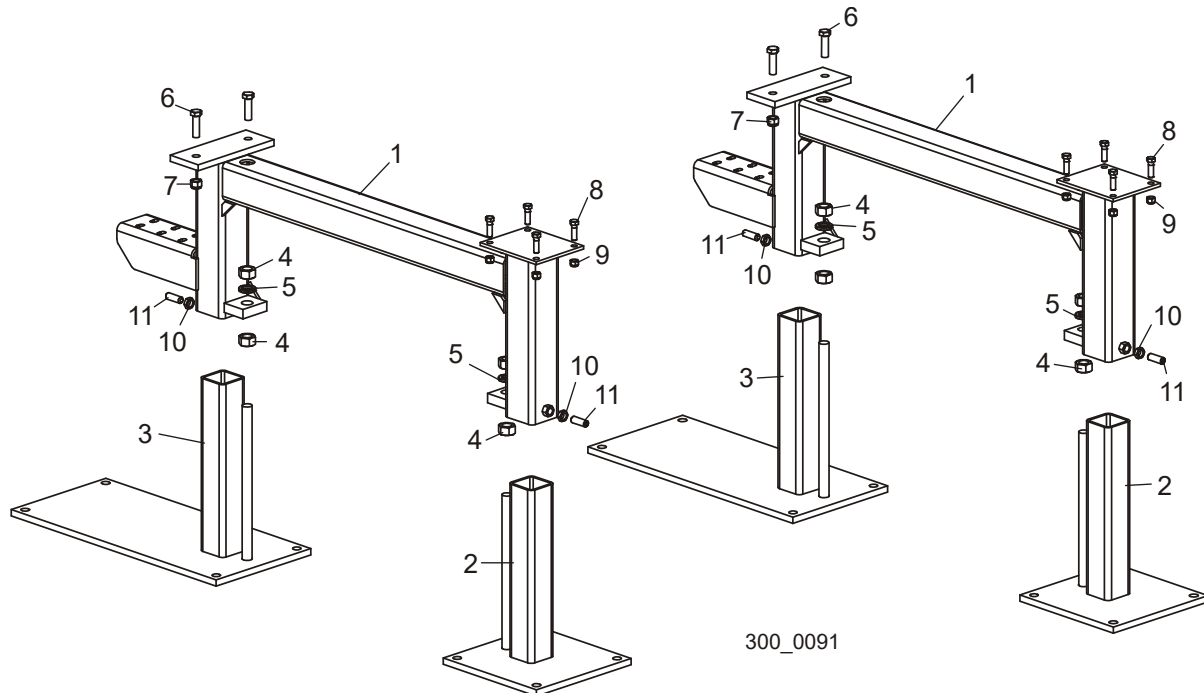

REF	DESCRIPTION (◆ Indicates Parts Available In Assemblies Only)	PART #	QTY.
	LEG ASSEMBLY, #3 & #4	036459 ¹	2
1	Leg Weldment, Short	036460	1
2	Plate Weldment, 10" x 10" Foot	051363	1
3	Plate Weldment, 10" x 22" Foot	051355	1
4	Nut, 3/4-16 Hex	F05010-92	4
5	Washer, 3/4" Split Lock	F05011-6	2
6	Bolt, 1/2-13 x 1 3/4" Hex Head Grade 5	F05008-88	2
7	Nut, 1/2-13 Hex Nylon Lock	F05010-8	2
8	Bolt, 3/8-16 x 1 1/4" Hex Head Grade 5	F05007-123	4
9	Nut, 3/8-16 Hex Nylon Lock	F05010-10	4
10	Nut, 1/2-13 Hex Jam	F05010-31	2
11	Screw, 1/2-13 x 1 1/2" Socket Head Flat Point Set	F05008-31	2

¹ Legs with cable carrier supports and longer foot plates supplied in kit 006806 instead of Pantograph for customers with space constraints.

7.12 Wireway

WM3500 (without Pantograph Cable Boom)

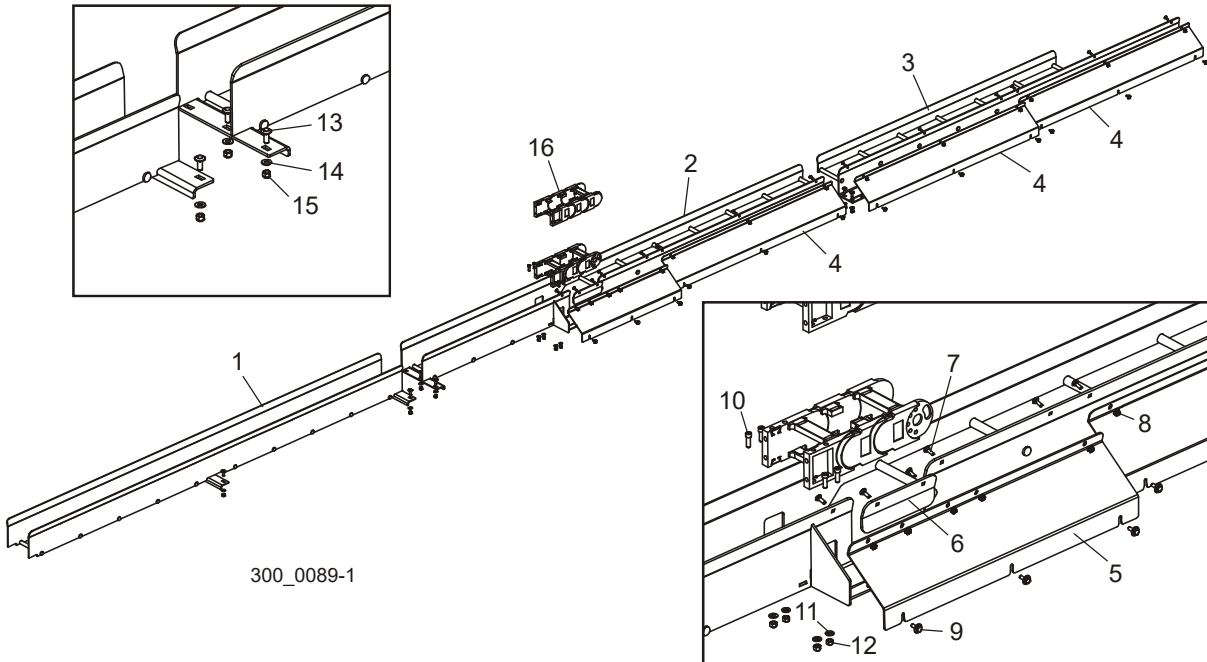

REF	DESCRIPTION (◆ Indicates Parts Available In Assemblies Only)	PART #	QTY.
	WIREWAY ASSEMBLY, 26' LT300 BED	036425 ¹	1
1	Wireway Weldment, 104.22" LT300	036430	1
2	Wireway Weldment, 111.90" LT300	036433	1
3	Wireway Weldment, 94.88" LT300	036427	1
4	Cover, LT300 Wireway 47.4"	036426	3
5	Cover, LT300 Wireway 27.66"	036446	1
6	Plate, LT300 Wireway Splice	036451	1
7	Bolt, 1/4-20 x 3/4" Carriage Head	F05005-113	14
8	Nut, 1/4-20 Self-Locking Hex	F05010-9	14
9	Bolt, 1/4-20 x 3/4" Hex Head w/Conical Washer	F05005-134	12
10	Bolt, 5/16-18 x 1" Socket Head	F05006-19	4
11	Washer, 5/16" SAE Flat	F05011-17	4
12	Nut, 5/16-18 Hex Lock	F05010-6	4
13	Bolt, 3/8-16 x 1" Carriage Head Grade 5	F05007-165	16
14	Washer, 3/8" SAE Flat	F05011-3	16
15	Nut, 3/8-16 Hex Nylon Lock	F05010-10	16
16	CABLE CARRIER PARTS (See Section 7.13)		

¹ Wireway supplied in kit 006806 instead of Pantograph for customers with space constraints.

7.13 Cable Carrier

WM3500 (without Pantograph Cable Boom)

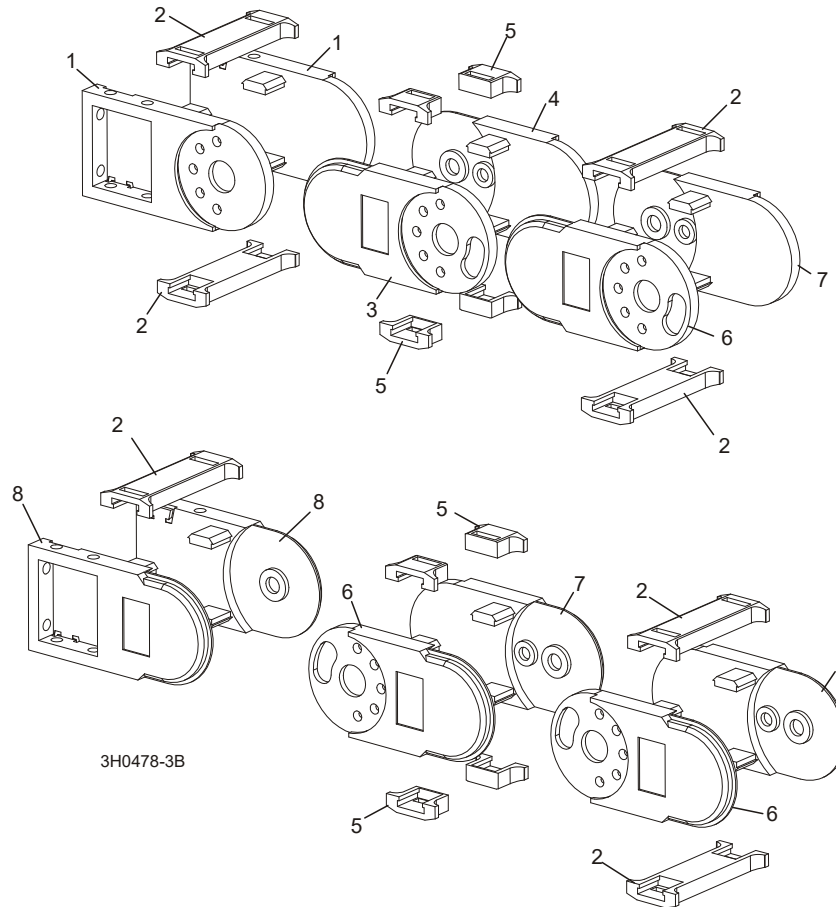

REF	DESCRIPTION (◆ Indicates Parts Available In Assemblies Only)	PART #	QTY.
	CARRIER CABLE, 4140-11-150AA X 46 LINKS LT300	036452 ¹	1
1	Link, Nylon Chain Top Mount	023612-3	2
2	Brace, Nylon Chain Long Cross	023612-4	46
3	Link, Nylon Chain Right Modified	036219-1	1
4	Link, Nylon Chain Left Modified	036220-1	1
5	Brace, Nylon Chain Short Cross	023612-5	92
6	Link, Nylon Chain Right Side #4040AA	036219	45
7	Link, Nylon Chain Left Side #4040AA	036220	45
8	Link, Nylon Chain Bottom Mount	023612-9	2

¹ Cable Carrier supplied in kit 006806 Rev. B4.00+ instead of Pantograph for customers with space constraints.

SECTION 8 HYDRAULICS

8.1 Hydraulic Log Loader Option

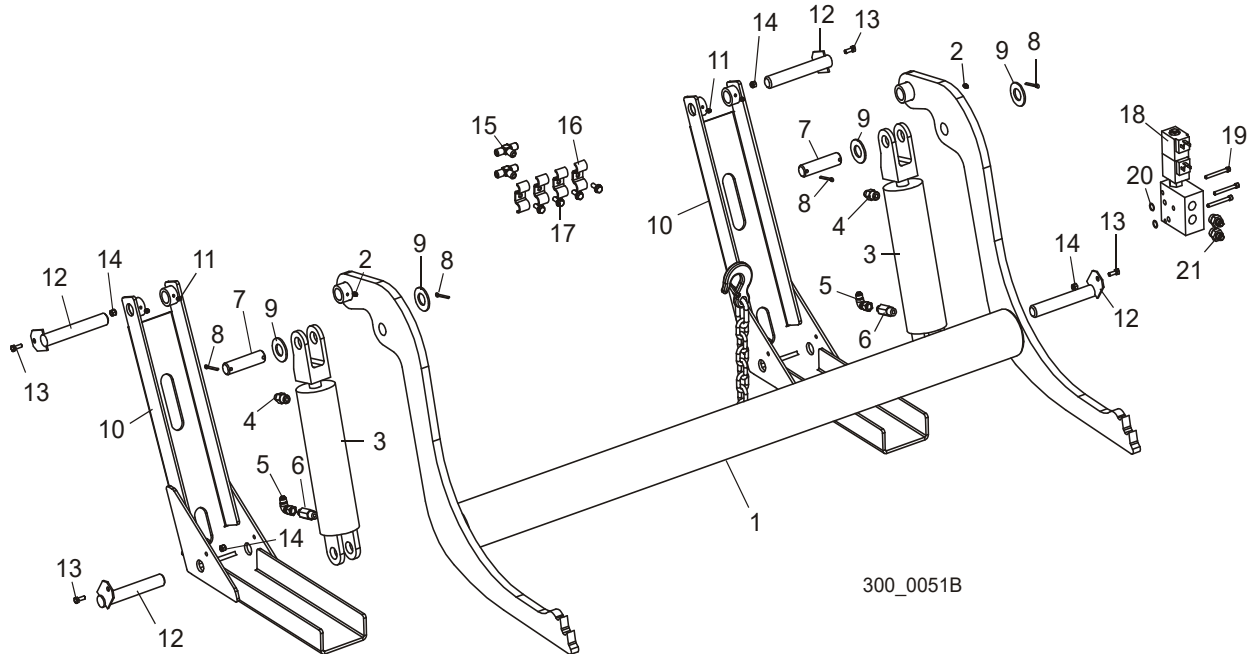

REF	DESCRIPTION (◆ Indicates Parts Available In Assemblies Only)	PART #	QTY.
	ARM ASSEMBLY, HYDRAULIC LOG LOADER	035613	1
1	Arm Weldment, Hydraulic Log Loader	036416-1	1
2	Fitting, 3/16" Straight Grease	P04107	2
3	Cylinder Assembly, 3" x 8" x 3/8" NPT 9.5GPM Hydraulic Log Loader	074401	2
3	Cylinder, 8" X 3" Hydraulic (3/8" NPT Ports)	042754	1
	Seal Kit, 8" x 3" Hydraulic Cylinder	P12956	1
4	Fitting, 3/8" NPT x 3/8" JIC Male Connector	016819	1
5	Fitting, 3/8" JIC 90° Swivel Elbow	042756	1
6	Fuse, 9.5GPM Velocity	074400	1
7	Pin, Loading Arm Cylinder Mount	S09251	2
8	Pin, 3/16" X 1 1/2" Cotter	F05012-23	4
9	Washer, 1" SAE Flat	F05011-28	4
10	Channel, Hydraulic Log Loading Foot	W09444	2
11	Fitting, 3/16" Grease	P04107	2
12	Pin, Loading Arm Mount	W09446	4
13	Bolt, 1/4-20 x 3/4" Hex Head Full Thread	F05005-1	4
14	Nut, 1/4-20 Hex Lock	F05010-69	4
15	Fitting, 3/8" JIC T	015487	2
16	Clamp, 3/8" Hose	016041	4
17	Bolt, 5/16-18 x 3/4" Self-Tapping Hex	F05015-30	4

8**Hydraulics***Hydraulic Log Loader Option*

	Hose Kit, Log Loader Option (See Section 8.14 for hose detail)	036552	1	
	Valve Assembly, Hydraulic Log Loader	036824	1	
18	Valve, 24V Hydraulic Add-On 4-Way Closed	025827	1	
	Valve, Hi-Flow Floating Center Hydraulic	045820	1	
	Coil, 24V Hydraulic #CAP-024D	051558	2	
19	Screw, 1/4-20 x 2 1/4" Socket Head	F05005-170	3	
20	O-Ring, 1/16" Dia. x 5/8" OD	036808	2	
21	Fitting, #8 SAE x #6 JIC	P12703	2	

8.2 Hydraulic Side Supports

[See Section 8.3](#) for middle side support.

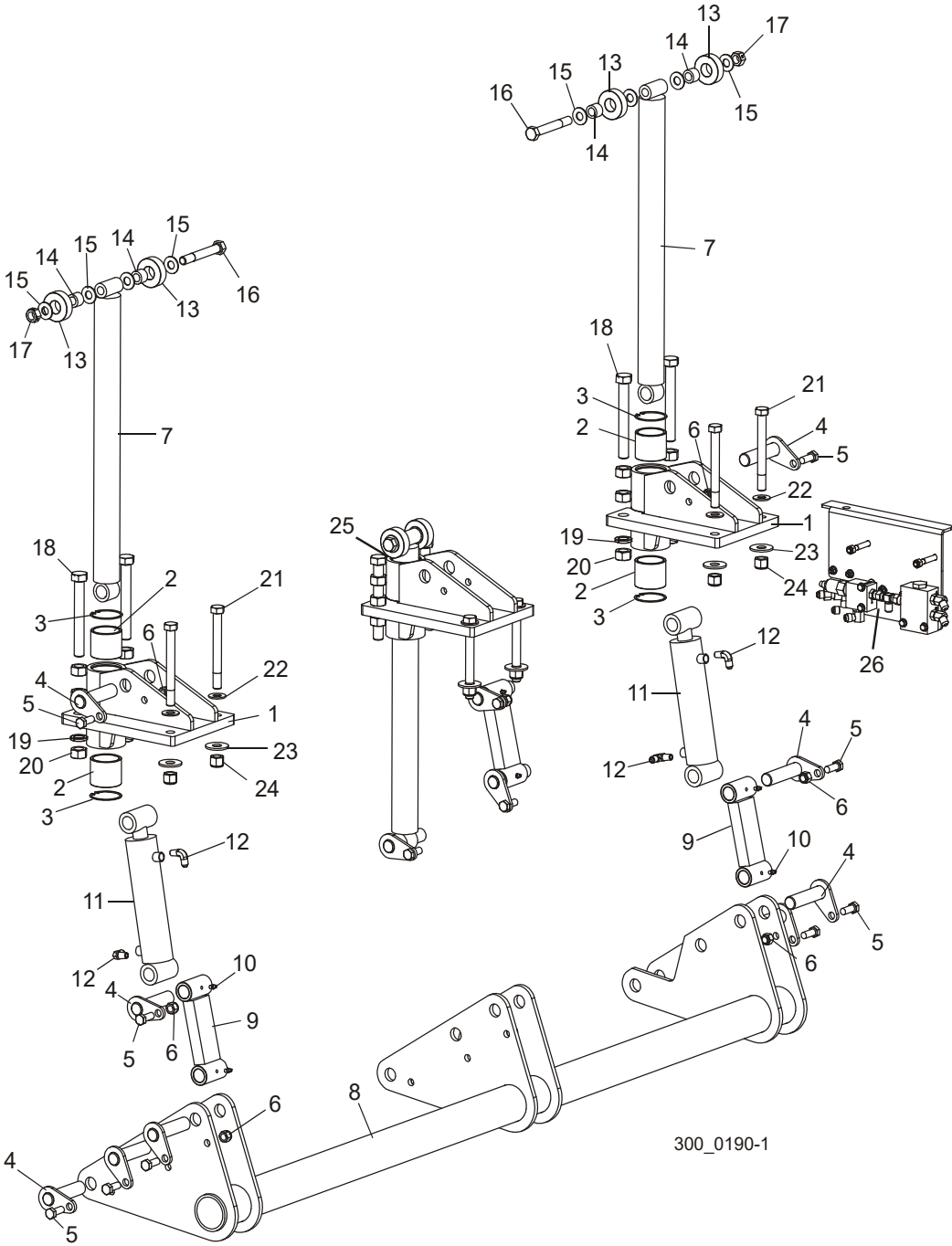

REF	DESCRIPTION (◆ Indicates Parts Available In Assemblies Only)	PART #	QTY.
	SUPPORT ASSEMBLY, HYDRAULIC LOG SIDE	063513	1
1	Bracket Weldment, Side Support Mount	042233	2

8

Hydraulics

Hydraulic Side Supports

2	Bushing, Side Support	042262	4	
3	Ring, 62mm DIN #472 Inside Retaining	F04254-12	4	
4	Pin Weldment, Side Support	042232	10	
5	Bolt, 1/2-13 x 1 1/4" Hex Head Grade 5	F05008-37	10	
6	Nut, 1/2-13 Hex Nylon Lock	F05010-8	10	
7	Rod Weldment, Side Support	042234	2	
8	Tube Weldment, Side Support Torque	063514	1	
9	Link Weldment, Side Support	042230	2	
10	Fitting, 1/4-28 Grease	P05060	4	
11	Cylinder, 2" x 6" Side Support	035625	2	
	Seal Kit, 2x6 Hydraulic Cylinder	003812	1	
12	Fitting, 3/8" JIC x 1/4" NPT 90° Elbow	015491	4	
	Roller Assembly, Side Support	035629	2	
13	Roller, Side Support	016561	2	
14	Bushing, 5/8" ID x 3/4" OD x 1" Long Bronze	016560	2	
15	Washer, 5/8" SAE Flat	F05011-5	4	
16	Bolt, 5/8-11 x 4 1/2" Hex Head Grade 5	F05009-10	1	
17	Nut, 5/8-11 Hex Lock	F05010-4	1	
18	Bolt, 3/4-10 x 6" Hex Head Full Thread	F05009-43	4	
19	Washer, 3/4" Split Lock	F05011-6	4	
20	Nut, 3/4-10 Hex	F05010-7	12	
21	Bolt, 5/8-11 x 6" Hex Head Grade 5	F05009-22	4	
22	Washer, 5/8" SAE Flat	F05011-5	4	
23	Washer, 5/8" Standard Flat	F05011-40	4	
24	Nut, 5/8-11 Hex Nylon Lock	F05010-34	4	
25	Middle Side Support Parts (See Section 8.3)			
26	Turner Sequence Valve Parts (See Section 8.11)			

8.3 Side Support (Middle)

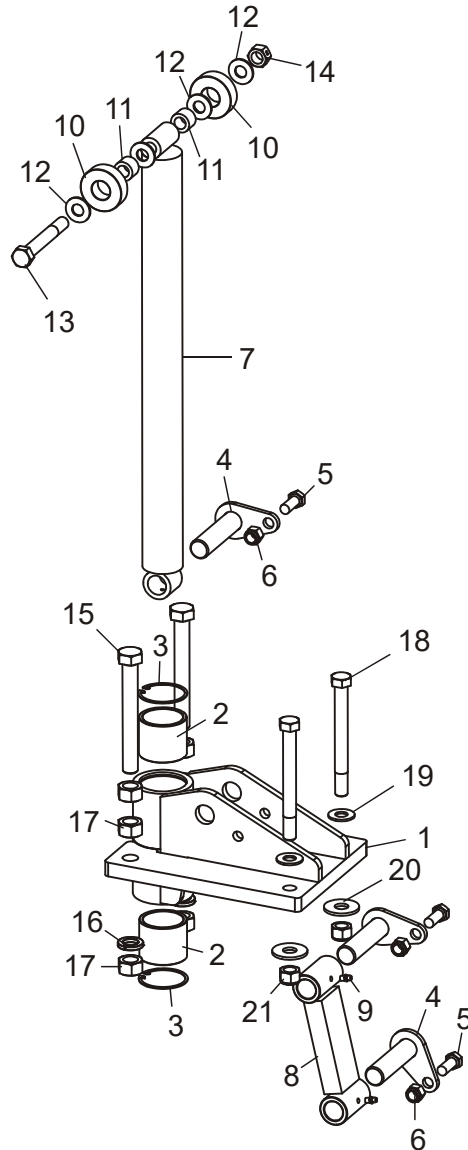

300_0126

REF	DESCRIPTION (◆ Indicates Parts Available In Assemblies Only)	PART #	QTY.
	SUPPORT ASSEMBLY, 3RD SIDE	038626	1
1	Bracket Weldment, Side Support Mount	042233	1
2	Bushing, Side Support	042262	2
3	Ring, 62mm DIN #472 Inside Retaining	F04254-12	2
4	Pin Weldment, Side Support	042232	3
5	Bolt, 1/2-13 x 1 1/4" Hex Head Grade 5	F05008-37	3
6	Nut, 1/2-13 Hex Nylon Lock	F05010-8	3
7	Rod Weldment, Side Support	042234	1

8**Hydraulics***Side Support (Middle)*

8	Link Weldment, Side Support	042230	1	
9	Fitting, 1/4-28 Grease	P05060	2	
	Roller Assembly, Side Support	035629	1	
10	Roller, Side Support	016561	2	
11	Bushing, 5/8" ID x 3/4" OD x 1" Long Bronze	016560	2	
12	Washer, 5/8" SAE Flat	F05011-5	4	
13	Bolt, 5/8-11 x 4 1/2" Hex Head Grade 5	F05009-10	1	
14	Nut, 5/8-11 Hex Lock	F05010-4	1	
15	Bolt, 3/4-10 x 6" Hex Head Full Thread	F05009-43	2	
16	Washer, 3/4" Split Lock	F05011-6	2	
17	Nut, 3/4-10 Hex	F05010-7	6	
18	Bolt, 5/8-11 x 6" Hex Head Grade 5	F05009-22	2	
19	Washer, 5/8" SAE Flat	F05011-5	2	
20	Washer, 5/8" Standard Flat	F05011-40	2	
21	Nut, 5/8-11 Hex Nylon Lock	F05010-34	2	

8.4 Hydraulic Log Turner

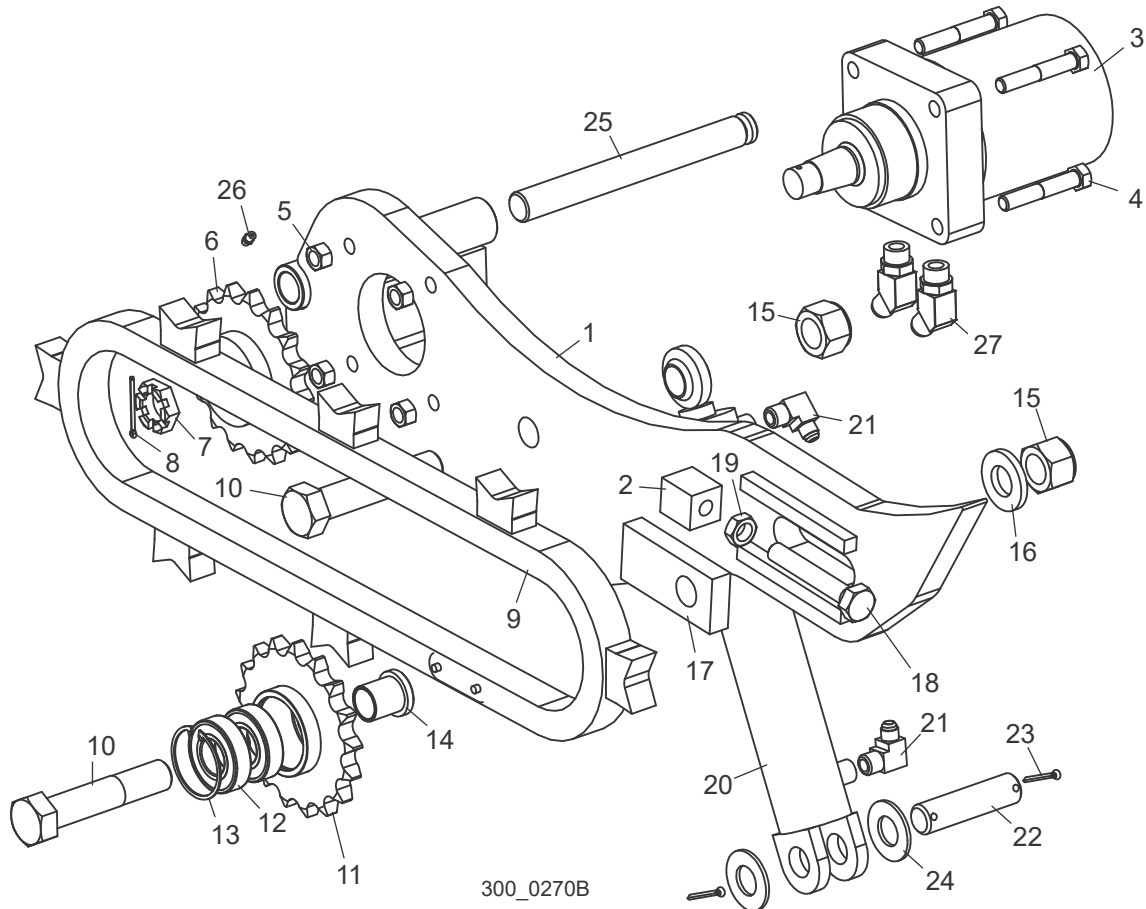

REF	DESCRIPTION (◆ Indicates Parts Available In Assemblies Only)	PART #	QTY.
	TURNER ASSEMBLY, WM3500 2-POINT CHAIN HYDRAULIC LOG	074161	2
1	Turner Weldment, 2-Point Chain Hydraulic Log	074027	1
2	Block, Turner Tensioner	042177	1
3	Motor, Hydraulic Log Turner	007331	1
	Kit, Seal Rebuild	061427	1
4	Bolt, 1/2-13 x 3" Hex Head Grade 5	F05008-23	4
5	Nut, 1/2-13 Hex Lock	F05010-3	4
6	Sprocket Weldment, Log Turner Drive	042192	1
7	Nut, Hydraulic Motor Castle	018741-2	1
8	Pin, 1/8" x 1 3/4" Cotter	F05012-43	1
9	Chain Weldment, Log Turner	006097	1
	Link, #2080H Master	016796	1
10	Bolt, 1-8 x 5" Hex Head Grade 8	F05004-132	2

8

Hydraulics

Hydraulic Log Turner

	Sprocket Assembly, Idler	042193	1	
11	Sprocket Weldment, Idler	042191	1	
12	Bearing, 6206 25 Idler	P11035	2	
13	Ring, 62mm #472 DIN Inside Retaining	F04254-12	1	
14	Spacer, Idler Sprocket	042187	2	
15	Nut, 1-8 Hex Lock	F05010-109	2	
16	Washer, 1" ID x 2" OD x 1/4"	038749	1	
17	Plate, Log Turner Chain Tensioner	042188	1	
18	Bolt, 5/8-11 x 4" Hex Head Full Thread Grade 5	F05009-31	1	
19	Nut, 5/8-11 Hex Jam	F05010-82	1	
20	Cylinder, 2" x 10" Welded Rod End Hydraulic	034267	1	
	Seal Kit, 2x10 Hydraulic Cylinder	003814	1	
21	Fitting, 3/8" NPT x 3/8" JIC 90° Elbow	016820	2	
22	Pin, 1" x 3.88"	S09251	1	
23	Pin, 3/16" x 1 1/2" Cotter	F05012-23	2	
24	Washer, 1" SAE Flat	F05011-28	2	
25	Rod, Grooved Turner Mount	006722	1	
26	Fitting, 1/4-28 Grease	P05060	1	
27	Fitting, #10SAE -1/2JIC 45 Elbow	016807	2	
	BOLT, 5/8-18 X 3 1/2" HEX HEAD BOLT FULL THREAD	F05009-16	1	
	NUT, 5/8-18 HEX	F05010-50	1	

8.5 Hydraulic Log Clamp

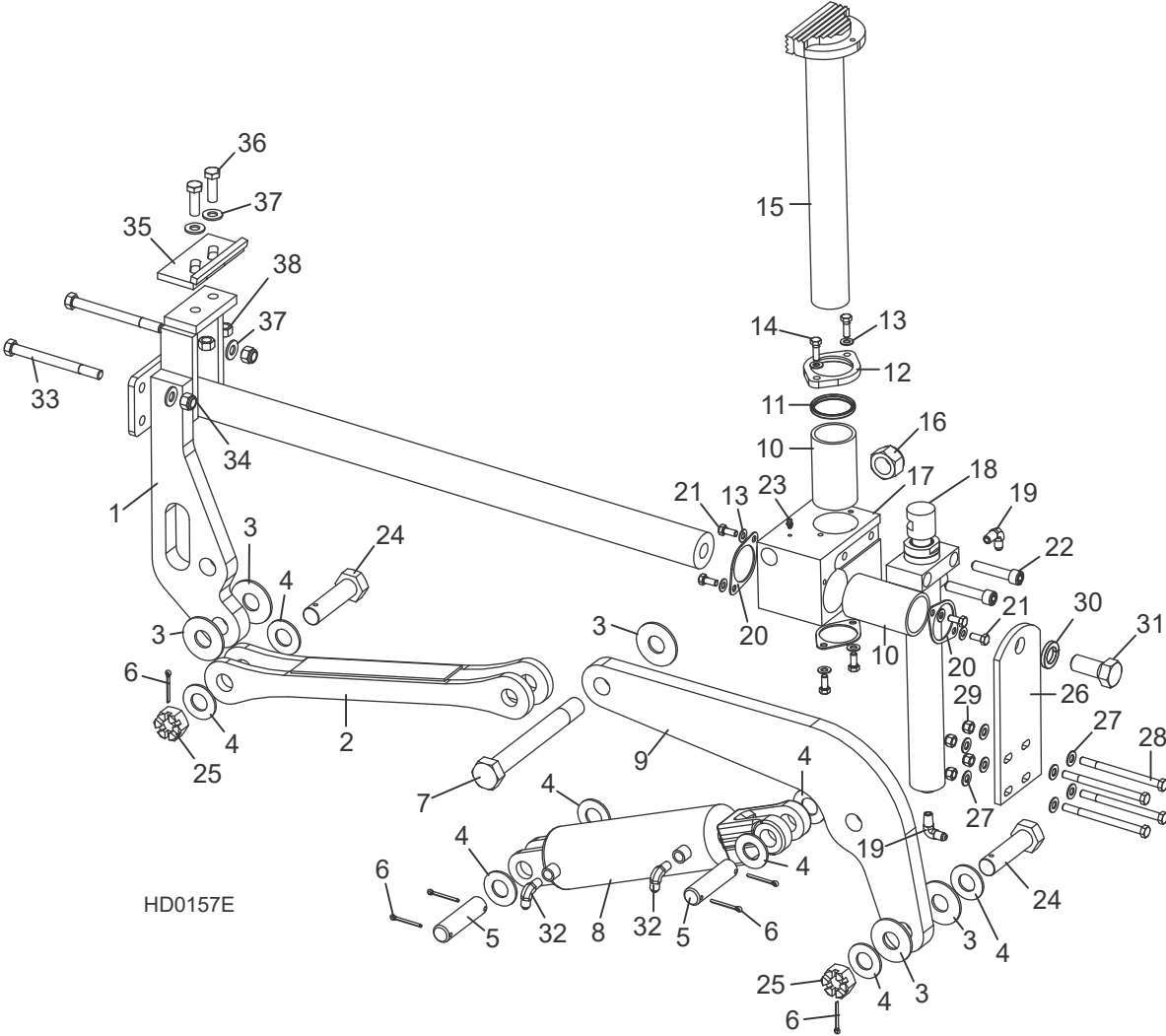

REF	DESCRIPTION (◆ Indicates Parts Available In Assemblies Only)	PART #	QTY.
	CLAMP ASSEMBLY, HYDRAULIC 2-PLANE	017264	1
1	Mount Weldment, Hydraulic Clamp Slide	017265	1
2	Link Weldment, Hydraulic Clamp	017267	1
3	Washer, 1/8" x 2 1/2" Hardened	015057	5
4	Washer, 1" SAE Flat	F05011-28	8
5	Pin, 1" x 3.88"	S09251	2
6	Pin, 3/16" x 1 1/2" Cotter	F05012-23	6
7	Bolt, 1-14 x 8 1/2" Hex Head Grade 8	015049	1
8	Cylinder, 3" x 7" Hydraulic	017275	1
	Seal Kit, Hydraulic Cylinder	P12956	1
9	Arm, Clamp Pivot	017274	1

8

Hydraulics

Hydraulic Log Clamp

10	Bushing, Clamp Slide	015088	2	
	Wiper Assembly, Vertical Clamp Rod	017271	1	
11	Wiper, Vertical Clamp Rod	017273	1	
12	Flange, Vertical Clamp Rod Wiper	017272	1	
13	Washer, 5/16" SAE Flat	F05011-17	8	
14	Bolt, 5/16-18 x 1" Hex Head	F05006-1	2	
15	Clamp Weldment, Vertical	015043	1	
16	Nut, 1-14 Nylon Lock	F05010-141	1	
17	Block, Hydraulic Clamp Slide	017270	1	
18	Cylinder Weldment, Vertical Clamp Hydraulic	015050	1	
	Seal Kit, Hydraulic Cylinder	016204	1	
	Instruction Sheet, Vertical Clamp Seal Replacement	016204-1009	1	
19	Fitting, 1/4" NPT x 1/4" JIC Elbow	P09142	2	
20	Retainer, Clamp Bushing	017242	3	
21	Bolt, 5/16-18 x 3/4" Hex Head	F05006-5	6	
22	Bolt, 1/2-13 x 2 1/2" Socket Head	F05008-39	2	
23	Fitting, 3/16" Straight Grease	P04107	1	
24	Bolt, 1-14 x 3 3/4" Hex Head Grade 8 w/Hole	015072	2	
25	Nut, 1-14 Slotted Hex	F05010-163	2	
26	Plate, Log Clamp Mount	015068	1	
27	Washer, 3/8" SAE Flat	F05011-3	8	
28	Bolt, 3/8-16 x 5" Hex Head	F05007-5	4	
29	Nut, 3/8-16 Hex Nylon Lock	F05010-10	4	
30	Washer, 7/8" Split Lock	F05011-46	1	
31	Bolt, 7/8-14 x 2" Hex Head Grade 5	F05014-2	1	
32	Fitting, 1/4" NPT - 3/8" JIC Elbow	015491	2	
33	Bolt, 1/2-13 x 5 1/2" Hex Head Grade 5	F05008-28	2	
34	Nut, 1/2-13 Hex Nylon Lock	F05010-8	2	
	Clamp Stop Kit, Hydraulic Log	K09485	1	
35	Plate, Clamp Stop	W09404	1	
36	Bolt, 1/2-13 X 1 1/2" Hex Head Grade 5	F05008-33	2	
37	Washer, 1/2" SAE Flat	F05011-2	2	
38	Nut, 1/2-13 Hex Lock	F05010-3	2	

8.6 Hydraulic Toe Board (Front)

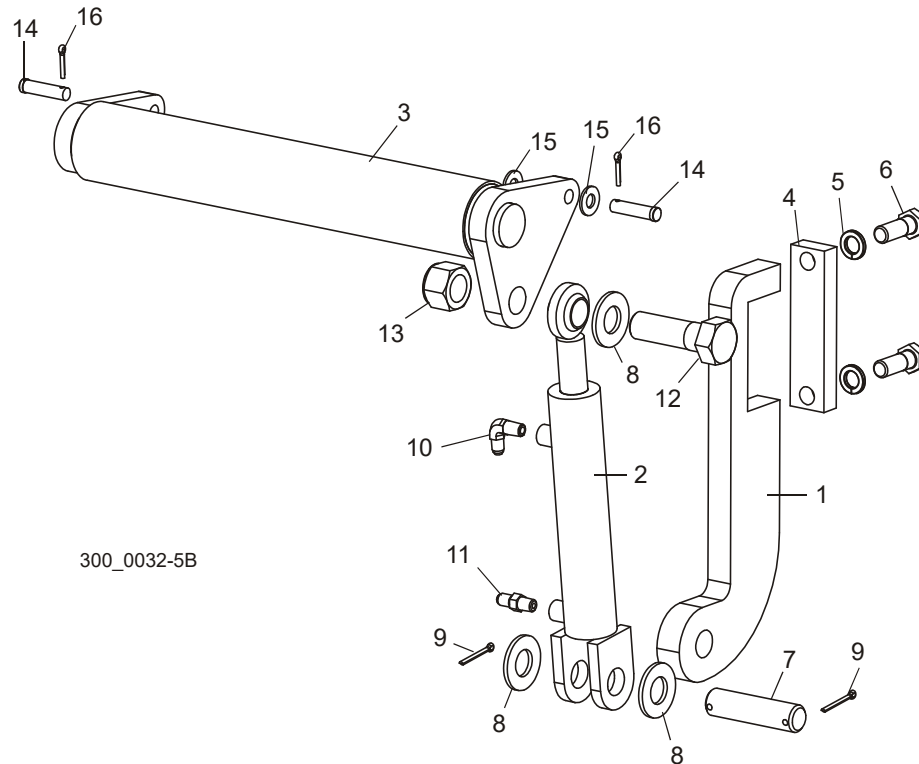

REF	DESCRIPTION (◆ Indicates Parts Available In Assemblies Only)	PART #	QTY.
	TOE BOARD ASSEMBLY, FRONT HYDRAULIC	035640	1
1	Plate, Hydraulic Toe Board Mount	S13022	1
2	Cylinder, 1 1/2" x 6" Toe Board	014482	1
	Seal Kit, 1 1/2" x 6" Hydraulic Cylinder	014547	1
3	Roller Assembly, Hydraulic Toe Board	074842	1
4	Plate, Toe Board Strap	S13023	1
5	Washer, 5/8" Split Lock	F05011-27	2
6	Bolt, 5/8-11 x 1 3/4" Hex Head	F05009-33	2
7	Pin, 1" x 3.88"	S09251	1
8	Washer, 1" SAE Flat	F05011-28	3
9	Pin, 3/16" x 1 1/2" Cotter	F05012-23	2
10	Fitting, 1/4" NPT x 1/4" JIC 90° Male Elbow	P09142	1
11	Fitting, 1/4" NPT x 1/4" JIC Straight Male	P09143	1
12	Bolt, 1-8 x 3 1/4" Hex Head Grade 5	F05009-51	1
13	Nut, 1-8 Hex Lock	F05010-109	1
14	Pin, 1/2" x 1 3/4" Clevis	F05012-82	2
15	Washer, 1/2" SAE Flat	F05011-2	2
16	Pin, 1/8" x 3/4" Cotter	F05012-3	2

8.7 Hydraulic Toe Board (Rear)

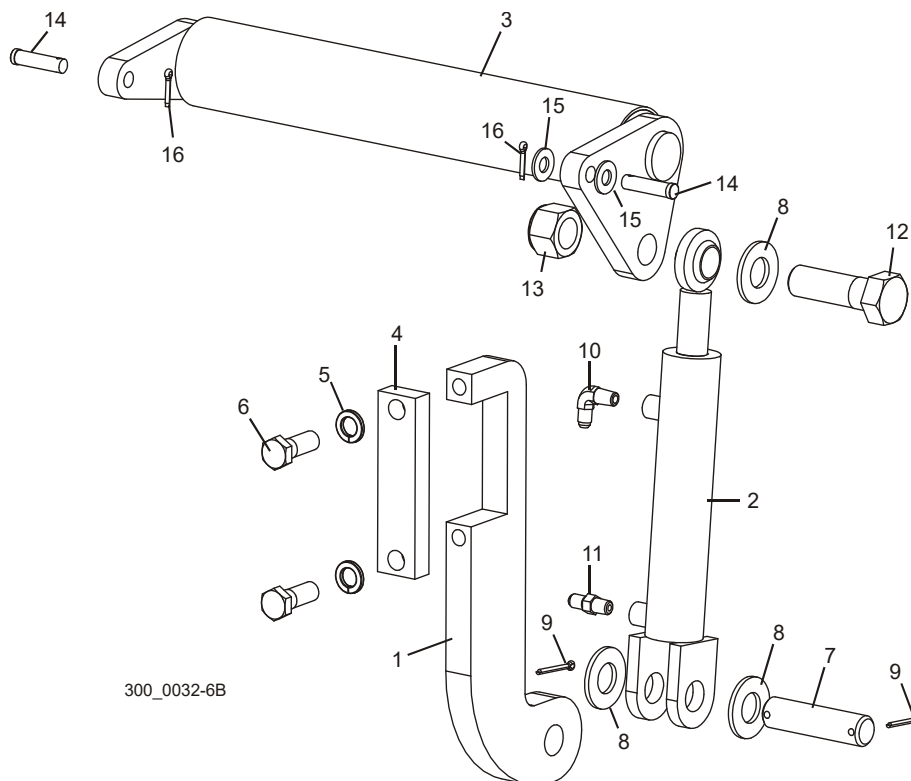

300_0032-6B

REF	DESCRIPTION (◆ Indicates Parts Available In Assemblies Only)	PART #	QTY.
	TOE BOARD ASSEMBLY, REAR HYDRAULIC	035642	1
1	Plate, Hydraulic Toe Board Mount	S13022	1
2	Cylinder, 1 1/2" x 6" Toe Board	014482	1
	Seal Kit, 1 1/2" x 6" Hydraulic Cylinder	014547	1
3	Roller Assembly, Hydraulic Toe Board	074851	1
4	Plate, Toe Board Strap	S13023	1
5	Washer, 5/8" Split Lock	F05011-27	2
6	Bolt, 5/8-11 x 1 3/4" Hex Head	F05009-33	2
7	Pin, 1" x 3.88"	S09251	1
8	Washer, 1" SAE Flat	F05011-28	3
9	Pin, 3/16" x 1 1/2" Cotter	F05012-23	2
10	Fitting, 1/4" NPT x 1/4" JIC 90° Male Elbow	P09142	1
11	Fitting, 1/4" NPT x 1/4" JIC Straight Male	P09143	1
12	Bolt, 1-8 x 3 1/4" Hex Head Grade 5	F05009-51	1
13	Nut, 1-8 Hex Lock	F05010-109	1
14	Pin, 1/2" x 1 3/4" Clevis	F05012-82	2
15	Washer, 1/2" SAE Flat	F05011-2	2
16	Pin, 1/8" x 3/4" Cotter	F05012-3	2

8.8 Hydraulic Pump & Tank

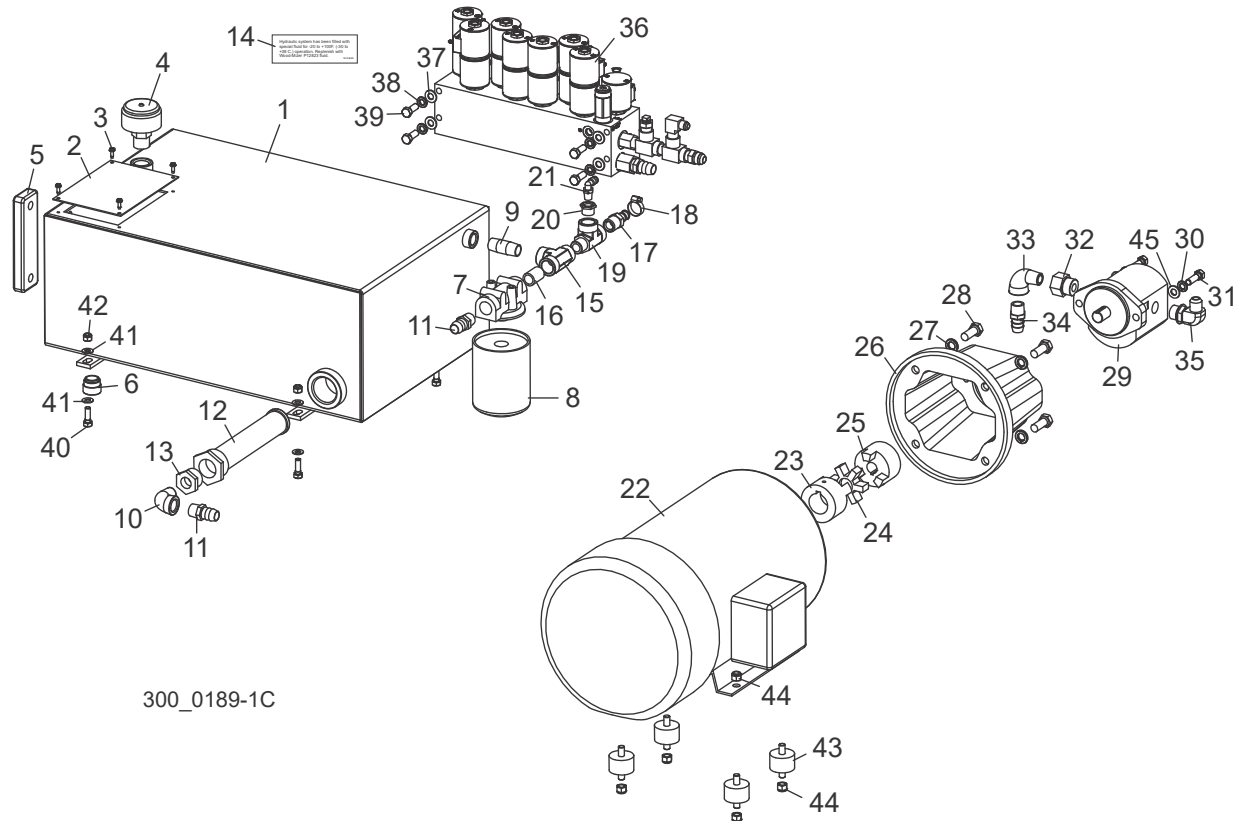

REF	DESCRIPTION (◆ Indicates Parts Available In Assemblies Only)	PART #	QTY.
	TANK ASSEMBLY, HYDRAULIC 10 GALLON	008933	1
1	Tank Weldment, 10 Gallon	038884	1
2	Cover, Hydraulic Tank Access	S20331	1
3	Bolt, #8-32 x 1/2" Slotted Hex Head	F05015-18	4
4	Cap, Hydraulic Breather/Filter	P20212	1
5	Guage, Hydraulic Fluid	P20211	1
6	Fitting, 1/2" NPT Pipe Plug	P26258	2
7	Filter Assembly, Hydraulic Manifold	P22683	1
8	Filter, S28 Hydraulic	P20301	1
9	Fitting, 1/2" NPT x 2" Black Pipe Nipple	016844	1
10	Fitting, 1/2" NPT ST Elbow	P22684	1
11	Fitting, 1/2" NPT Male x 3/4" Hose Barb	035621	2
12	Filter, Hydraulic Tank Suction	P20210	1
13	Fitting, 1/2" x 1" Reducer Bushing	P20239	1
14	Decal, Hydraulic Fluid Replacement	S12825	1
15	Fitting, 1/2" NPT Female Tee	016793	1

8

Hydraulics*Hydraulic Pump & Tank*

16	Fitting, 1/2" NPT Close Brass Nipple	016795	1	
17	Fitting, 1/2" NPT Male x 1/2" Hose Barb	016794	1	
18	Clamp, 11/16" Worm	P12739	1	
19	Fitting, 1/2" NPT Male Run Tee	003674	1	
20	Fitting, 1/2" NPT x 1/4" NPT Reducer Hex Bushing	P31321	1	
21	Fitting, 1/4" NPT x 1/4" Tube 90° Elbow	P21519	1	
	PUMP ASSEMBLY, 10HP HYDRAULIC	008743	1	
22	Motor, 10 HP 2525RPM	008737	1	
23	Coupling, L100 x 1 3/8" Body	042777	1	
24	Coupling, L100 Spider	042779	1	
25	Coupling, L100 x 3/4" Body	042778	1	
26	Adaptor, Hydraulic Pump/50Hz Motor	042781	1	
27	Washer, 1/2" Split Lock	F05011-9	4	
28	Bolt, 1/-13 x 1 1/4" Hex Head Grade 5	F05008-37	4	
29	Pump, 9 GPM Hydraulic	008738	1	
30	Washer, 3/8" Split Lock	F05011-4	2	
31	Bolt, 3/8-16 x 1 1/4" Hex Head Grade 5	F05007-123	2	
32	Fitting, 1/2" NPT x #12 SAE Female Adaptor	042785	1	
33	Fitting, 1/2" NPT Galvanized Elbow	P22684	1	
34	Fitting, 1/2" NPT x 3/4" Hose Barb	035621	1	
35	Fitting, #10 SAE x 1/2" JIC 90° Elbow	042784	1	
36	VALVE PARTS (See Section 8.10)			
37	WASHER, 3/8" SAE FLAT	F05011-3	4	
38	WASHER, 3/8" SPLIT LOCK	F05011-4	4	
39	BOLT, 3/8-16 X 1" HEX HEAD GRADE 5	F05007-87	4	
40	BOLT, 5/16-18 X 1" HEX HEAD	F05006-1	4	
41	WASHER, 5/16" SAE FLAT	F05011-17	8	
42	NUT, 5/16-18 HEX NYLON LOCK	F05010-58	4	
43	MOUNT, RUBBER HYDRAULIC MOTOR	035546	4	
44	NUT, 3/8-16 HEX NYLON LOCK	F05010-10	8	
45	WASHER, 3/8 FLAT SAE	F05011-3	2	

8.9 Hydraulic Toe Board (Rear w/Ramp)

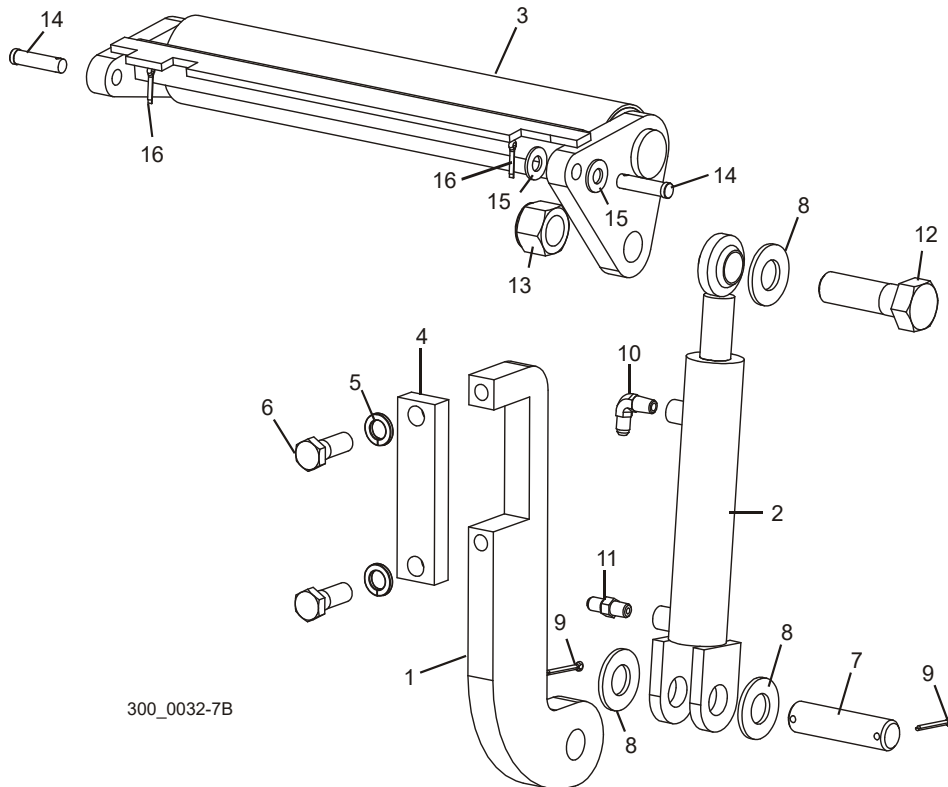

REF	DESCRIPTION (◆ Indicates Parts Available In Assemblies Only)	PART #	QTY.
	TOE BOARD ASSEMBLY, REAR HYDRAULIC W/RAMP	035564	1
1	Plate, Hydraulic Toe Board Mount	S13022	1
2	Cylinder, 1 1/2" x 6" Toe Board	014482	1
	Seal Kit, 1 1/2" x 6" Hydraulic Cylinder	014547	1
3	Roller Assembly, Hydraulic Toe Board (w/Ramp)	074857	1
4	Plate, Toe Board Strap	S13023	1
5	Washer, 5/8" Split Lock	F05011-27	2
6	Bolt, 5/8-11 x 1 3/4" Hex Head	F05009-33	2
7	Pin, 1" x 3.88"	S09251	1
8	Washer, 1" SAE Flat	F05011-28	3
9	Pin, 3/16" x 1 1/2" Cotter	F05012-23	2
10	Fitting, 1/4" NPT x 1/4" JIC 90° Male Elbow	P09142	1
11	Fitting, 1/4" NPT x 1/4" JIC Straight Male	P09143	1
12	Bolt, 1-8 x 3 1/4" Hex Head Grade 5	F05009-51	1
13	Nut, 1-8 Hex Lock	F05010-109	1
14	Pin, 1/2" x 1 3/4" Clevis	F05012-82	2
15	Washer, 1/2" SAE Flat	F05011-2	2
16	Pin, 1/8" x 3/4" Cotter	F05012-3	2

8.10 Hydraulic Valve

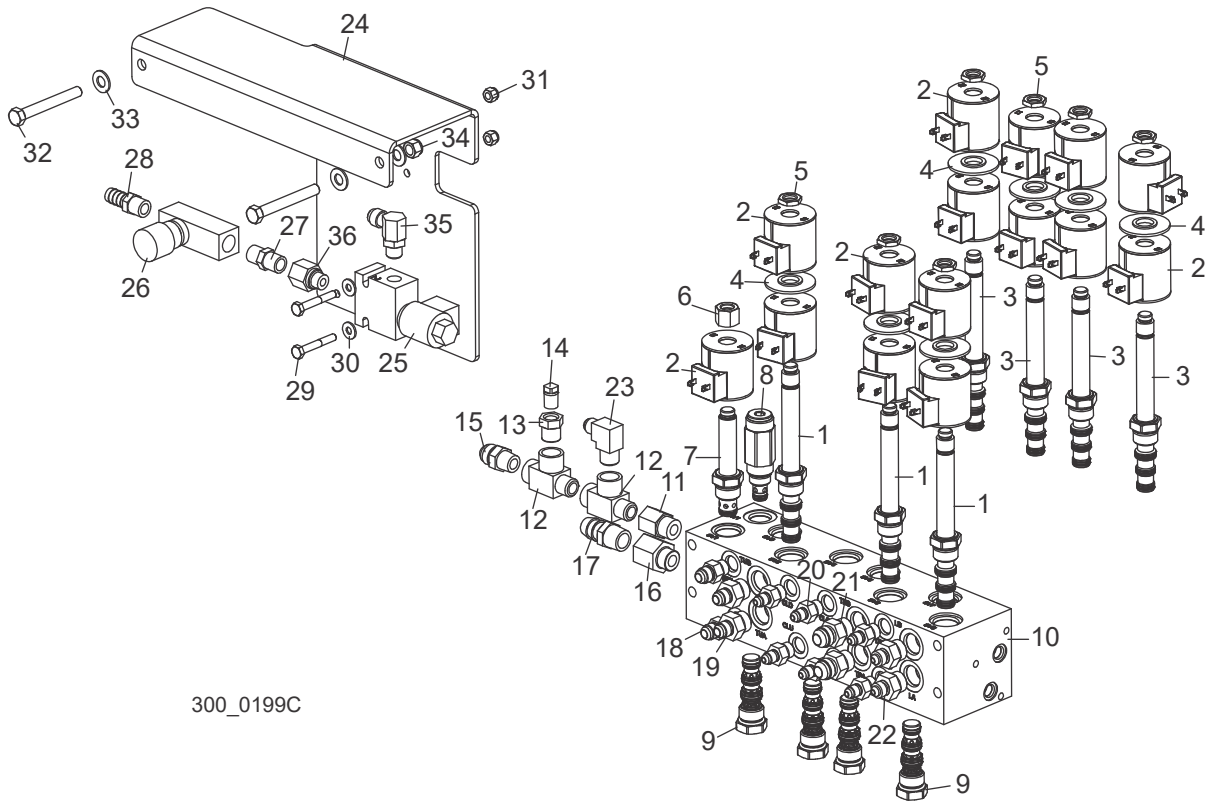

300_0199C

REF	DESCRIPTION (◆ Indicates Parts Available In Assemblies Only)	PART #	QTY.
	VALVE ASSEMBLY, WM3500 HYDRAULIC	008932 ¹	1
	Valve, 7-Spool Expandable Hydraulic	025689	1
1	Valve, SV10-47C Hydraulic (Loader, Turner, Side Supports)	025830	3
	Kit, Seal SK10-4N-MMM One Per Spool	061104	1
2	Coil, 24VDC Hydraulic Valve	025835	15
3	Valve, SV10-47D Hydraulic (Clamp, Toe Boards)	025829	4
	Kit, Seal SK10-4N-MMM One Per Spool	061104	1
4	Spacer, SV10-47 Valve Coil	025838	7
5	Nut, SV10-47 Valve Coil	025837	7
6	Nut, SV10-21 Valve Coil	025836	1
7	Valve, SV10-21 Hydraulic (By-Pass)	025831	1
	Kit, Seal SK10-2N-T One Per Spool	061105	1
8	Valve, Relief (SK08-2N-T)	025833	1
	Kit, Seal SK08-2N-T Relief Valve	061107	1
9	Valve, Dual PO Check (DC10-40)	025832	4
	Kit, Seal SK10-4N-MMM One Per Spool	061104	1
10	Manifold, M&W 07-0667 Black Anodized	061284	1

11	Fitting, #8 SAE x 3/8" NPT Female Adapter	P12706	1	
12	Fitting, 3/8" NPT Male Run Tee	016822	2	
13	Fitting, 3/8" NPT-1/4 NPT Reducer	015490	1	
14	Plug, 1/4" NPT Pipe	P05498	1	
15	Fitting, 3/8" NPT x #8 JIC	036822	1	
16	Fitting, #8SAE x 1/2" NPT Female Adapter	035620	1	
17	Fitting, 1/2" NPT x 3/4" Hose Barb	035621	1	
18	Fitting, 3/8" O-Ring x 3/8" JIC	014687	2	
19	Fitting, #8 SAE x #6 JIC	P12703	2	
20	Fitting, 1/4" JIC x 3/8" O-Ring	P26284	6	
21	Fitting, #8 SAE x #8 JIC	028076	2	
22	Fitting, #8 SAE x 1/4" JIC	036759	2	
23	Fitting, 3/8" NPT x 3/8" JIC 90° Elbow	016820	1	
	VALVE ASSEMBLY, FLOW CONTROL	008926	1	
24	Plate, Diverter Valve Mount	007272	1	
25	Valve, Solenoid Poppet 2-Way Normally Open	008739	1	
26	Valve, Hydraulic Flow Control	008740	1	
27	Fitting, 3/8" NPT Hex Nipple	008928	1	
28	Fitting, 3/8" NPT Male x 1/2" Hose Barb	008929	1	
29	Bolt, 1/4-20 x 1 3/4" Hex Head Grade 5	F05005-68	2	
30	Washer, 1/4" SAE Flat	F05011-11	2	
31	Nut, 1/4-20 Hex Nylon Lock	F05010-69	2	
32	Bolt, 3/8-16 x 3" Hex Head Full Thread	F05007-1	2	
33	Washer, 3/8" SAE Flat	F05011-3	4	
34	Nut, 3/8-16 Hex Nylon Lock	F05010-10	2	
35	Fitting, #6 SAE x 3/8" JIC Elbow	P12704	1	
36	Fitting, 3/8" SAE x 3/8" NPT Adaptor	006487	1	

¹ Torque cartridge spools to 24-26 ft-lbs. Torque coil nuts to 7-10 ft-lbs.

8.11 Hydraulic Turner Sequence Valve

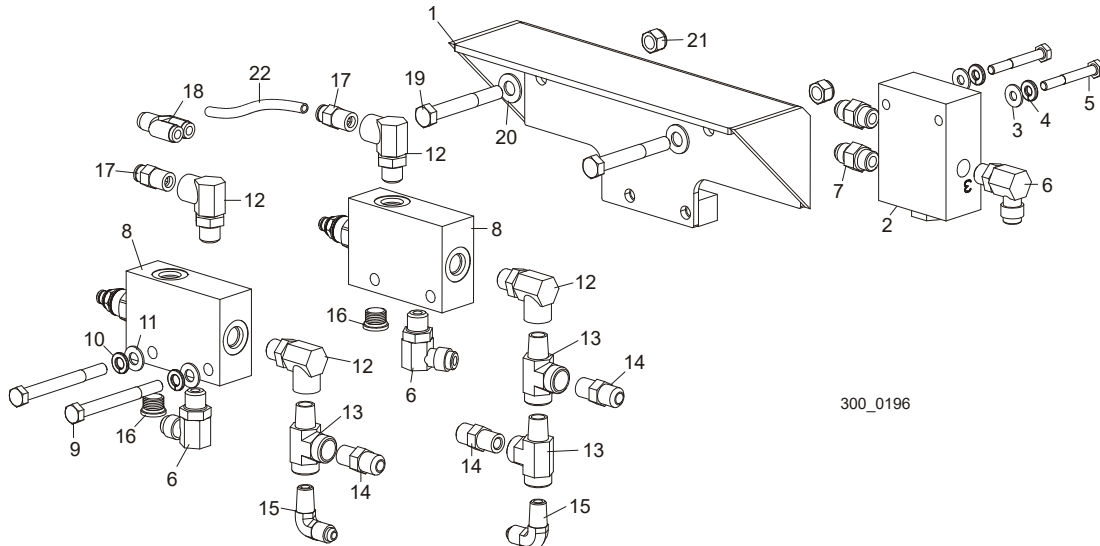

REF	DESCRIPTION (◆ Indicates Parts Available In Assemblies Only)	PART #	QTY.
	VALVE ASSEMBLY, WM3500 HYDRAULIC TURNER SEQUENCE	025720	1
1	Mount Weldment, 2-Turner Sequence Valve	025723	1
2	Valve, Hydraulic Flow Divider	025742	1
3	Washer, 1/4" SAE Flat	F05011-11	2
4	Washer, 1/4" Split Lock	F05011-14	2
5	Bolt, 1/4-20 x 2" Hex Head Grade 5	F05005-125	2
6	Fitting, #6 SAE x 3/8" JIC Elbow	P12704	3
7	Fitting, 3/8" O-Ring x 3/8" JIC	014687	2
8	Valve, Vented Hydraulic Sequence	025718	2
9	Bolt, 5/16-18 x 3 1/4" Hex Head Grade 5	F05006-133	2
10	Washer, 5/16" Split Lock	F05011-13	2
11	Washer, 5/16" SAE Flat	F05011-17	2
12	Fitting, #6 SAE x 1/4" NPT Elbow	025744	4
13	Fitting, 1/4" NPT Male Run Tee	P09141	3
14	Fitting, 3/8" JIC x 1/4" NPT	015560	3
15	Fitting, 3/8" JIC x 1/4" NPT 90° Elbow	015491	2
16	Fitting, #6 SAE Plug	025743	2
17	Fitting, 1/4" NPT x 1/4" Tube	P20903	2
18	Fitting, 1/4" Tube 'Y'	042546	1
19	Bolt, 3/8-16 x 2 3/4" Hex Head Grade 5	F05007-206	2
20	Washer, 3/8" SAE Flat	F05011-3	2
21	Nut, 3/8-16 Hex Nylon Lock	F05010-10	2
22	Tube, 1/4" Chainflex Air Line	R01869-3	16 Ft.

8.12 Power Taper Set Roller (Optional)

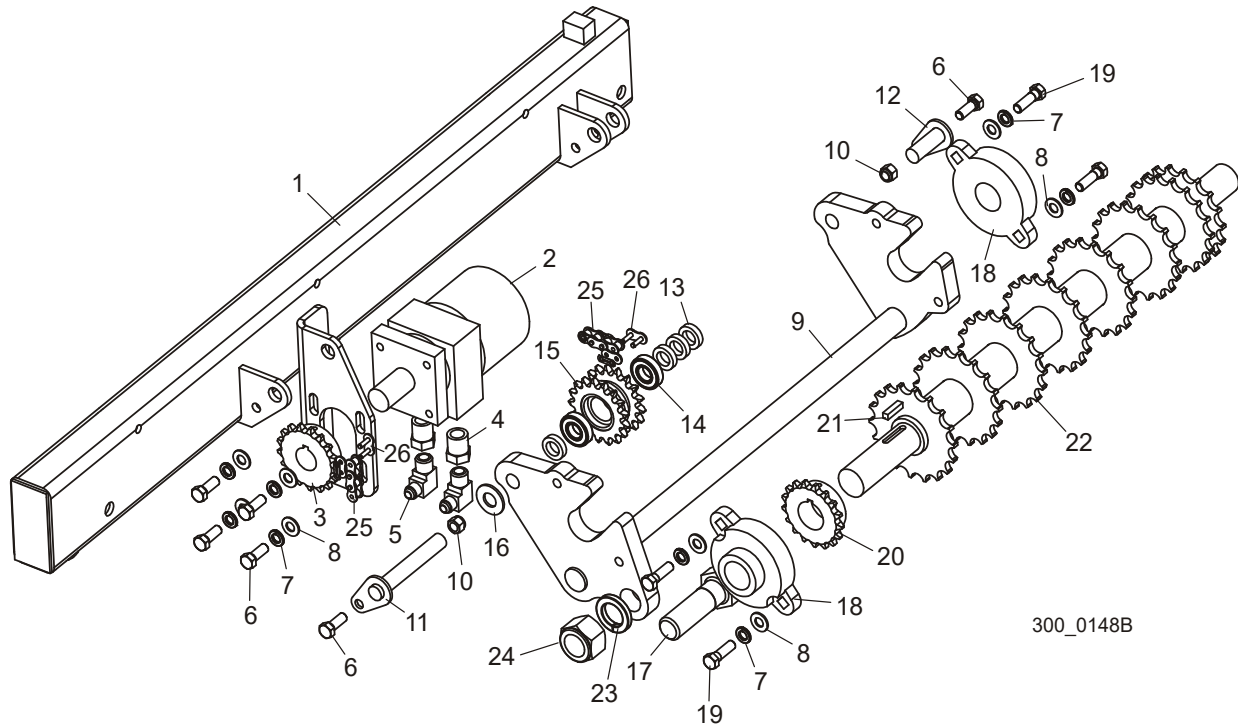

REF	DESCRIPTION (◆ Indicates Parts Available In Assemblies Only)	PART #	QTY.
	TUBE ASSEMBLY, REAR POWER TAPER SET ROLLER	003873	1
	TUBE ASSEMBLY, FRONT POWER TAPER SET ROLLER	006676	1
1	Tube Weldment, Rear Power Taper Set Roller	003875	1
	Tube Weldment, Front Power Taper Set Roller	006678	1
2	Motor, Hydraulic #MG06-13-13AAAB	P21506	1
	Seal Kit, Hydraulic Motor	061136	1
3	Sprocket, 40B17 x 1"	003883	1
4	Fitting, 1/2" NPT x 3/8" NPT Hex Reducer	028073	2
5	Fitting, 3/8" NPT-3/8" JIC 90 Elbow	016820	2
6	Bolt, 3/8-16 x 1" Hex Head Grade 5	F05007-87	7
7	Washer, 3/8" Split Lock	F05011-4	7
8	Washer, 3/8" Flat SAE	F05011-3	8
9	Roller Weldment, Rear Toe Board	003879	1
	Roller Weldment, Front Toe Board	006679	1
10	Nut, 3/8-16 Hex Nylon Lock	F05010-10	2
11	Pin Weldment, 5/8" x 4 1/16"	003886	1
12	Pin Weldment, 5/8" x 1 3/4"	003887	1

8

Hydraulics*Power Taper Set Roller (Optional)*

13	Spacer, .63" x 1.00" x .25"	017719	4	
14	Bearing, R-10	P04156	2	
15	Sprocket Wedment, Dual 17/17T	W12474	1	
16	Washer, 5/8" SAE Flat	F05011-5	1	
17	Washer, 3/8" ID x 1 1/4" OD	S02779	1	
18	Bearing, 1 1/4" Flange, IPTCI	003896	1	
19	Bolt, 3/8-16 x 1 1/4" Hex Head Grade 5	F05007-123	4	
20	Sprocket, 40B17 x 1 1/4"	003884	1	
21	Key, 1/4" x 1"	S21486	1	
22	Roller, Powered Toeboard	003881	1	
23	Washer, 1" Split Lock	F05011-53	1	
24	Nut, 1-8 Self-Locking Hex	F05010-109	1	
25	Chain, #40 x 32 Pitch	003895	2	
26	Link, #40 Master	P04200	2	

8.13 Valve Assembly, Power Taper Set Roller (Optional)

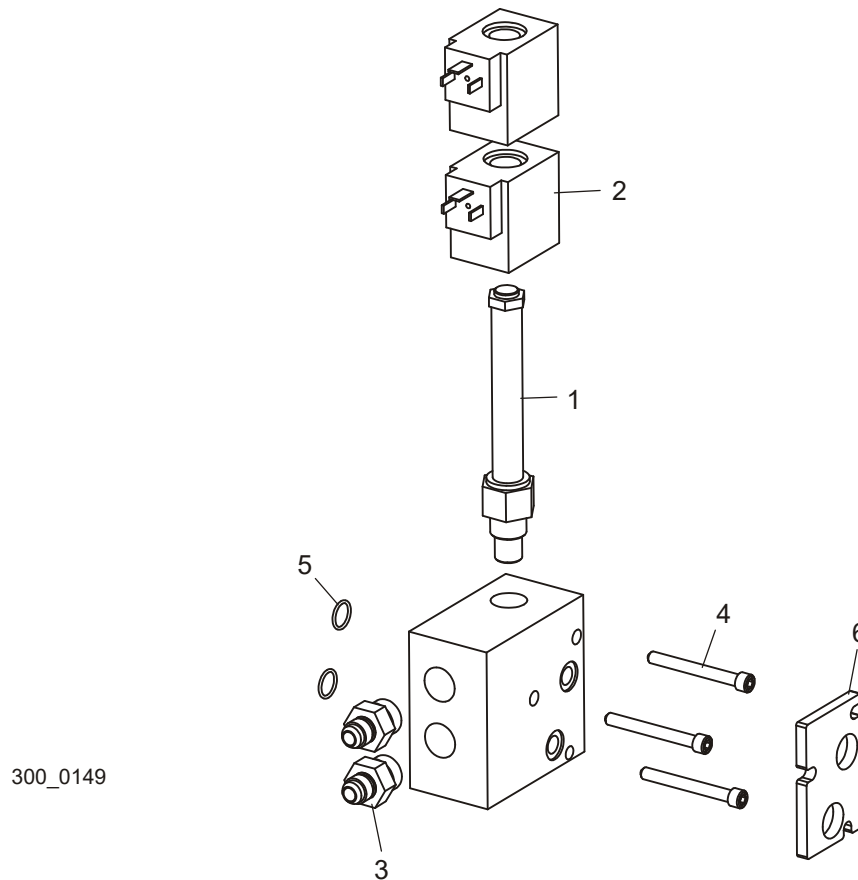

REF	DESCRIPTION (◆ Indicates Parts Available In Assemblies Only)	PART #	QTY.
	VALVE ASSEMBLY, 300LA ADD-ON	036824	1
	Valve, 24V Hydraulic Add-On 4-Way Closed	025827	1
1	Valve, Hi-Flow Floating Center Hydraulic	045820	1
2	Coil, 24V Hydraulic #CAP-024D	051558	2
3	Fitting, 8 SAE-3/8" JIC	P12703	2
4	Screw, 1/4-20 x 2 1/4" Socket Head Cap	F05005-170	3
5	O-Ring, .070" Dia. x 5/8" OD #2-014 Buna-N	036806	2
6	PLATE, ADD-ON VALVE SPACER (W/ADDITIONAL VALVES ONLY)	003929	1
	SCREW, 1/4-20 X 6 1/2" SOCKET HEAD CAP (W/ADDITIONAL VALVES ONLY)	F05005-182	3

8.14 Hydraulic Hoses

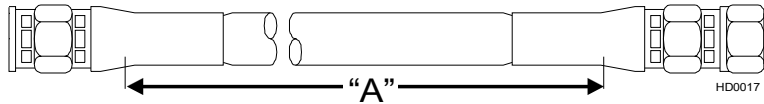

COLOR	LENGTH "A" WM3500	LENGTH "A" WM3500-BX6	DESCRIPTION	Part No. WM3500	LENGTH "A" WM3500-BX6
			GROMMET, 2 1/2" DIAMETER RUBBER	085614	
			GROMMET, 4 3/8" X 10" OVAL	N/A	085759
1/4" Hydraulic Hoses					
Yellow	158"	230"	1/4" TOE BOARD #1 TOP	036566	
Grey	158"	230"	1/4" TOE BOARD #1 BASE	036566	
Purple	247"	319"	1/4" TOE BOARD #2 TOP	036067	
Black	243"	315"	1/4" TOE BOARD #2 BASE	036567	
Red	283"	355"	1/4" TOE BOARD #3 TOP	036568	
Blue	281"	353"	1/4" TOE BOARD #3 BASE	036569	
Yellow	256"	328"	1/4" CLAMP UP/DOWN BASE	036560	
Green	268"	340"	1/4" CLAMP UP/DOWN TOP	036066	
3/8" Hydraulic Hoses					
Pink	208"	296"	3/8" LOG TURNER IN/OUT BASE		
Plain	208"	296"	3/8" LOG TURNER IN/OUT TOP		
White	220"	292"	3/8" CLAMP IN/OUT TOP	036563	
Orange	211"	283"	3/8" CLAMP IN/OUT BASE	036069	
Plain		42"	3/8" 2-SPEED FLOW CONTROL		
Plain		27"	3/8" SIDE SUPPORT #1 BASE BRANCH 'T'		
Plain		19"	3/8" SIDE SUPPORT #1 ROD BRANCH 'T'		
Plain		64"	3/8" SIDE SUPPORT #2 BASE BRANCH 'T'		
Plain		56"	3/8" SIDE SUPPORT #2 ROD BRANCH 'T'		
Plain		21"	3/8" SIDE SUPPORT T-VALVE		
Plain		21"	3/8" SIDE SUPPORT T-VALVE		
Plain		25"	3/8" LOG TURNER CYLINDER		
Plain		35"	3/8" LOG TURNER CYLINDER		
Plain		71"	3/8" LOG TURNER CYLINDER		
Plain		75"	3/8" LOG TURNER CYLINDER		
Plain			3/8" BX SIDE SUPPT BRANCH (TURNER 'T')		
Plain			3/8" BX SIDE SUPPT BRANCH (TURNER 'T')		
Plain			3/8" BX SIDE SUPPT BRANCH ('T' FRONT TOP)		

Plain			3/8" BX SIDE SUPPT BRANCH ('T' REAR TOP)		
Plain			3/8" BX SIDE SUPPT BRANCH ('T' FRONT BASE)		
Plain			3/8" BX SIDE SUPPT BRANCH ('T' REAR BASE)		
Pink			3/8" VALVE TO INSIDE FLOW DIVIDER #3		
Plain			3/8" VALVE TO OUTSIDE FLOW DIVIDER #3		
Pink			3/8" FLOW DIVIDER #2 TO DIVERTER VALVE #2		
Plain			3/8" FLOW DIVIDER #2 TO DIVERTER VALVE #2		
Pink			3/8" FLOW DIVIDER #4 TO T-FITTING		
Plain			3/8" FLOW DIVIDER #4 TO T-FITTING		
Pink			3/8" DIVERTER VALVE #3 TO T-FITTING		
Plain			3/8" DIVERTER VALVE #3 TO T-FITTING		
Pink			3/8" DIVERTER VALVE #1 TO BX TURNER BASE		
Plain			3/8" DIVERTER VALVE #1 TO BX TURNER TOP		
1/2" Hydraulic Hoses					
Black	231"	303"	1/2" TURNER MOTOR #2		
Purple	184"	256"	1/2" TURNER MOTOR #1		
Plain	75"		1/2" TURNER #1 TO TURNER #2		
Plain	24"		1/2" MOTOR TO VALVE		036079
Purple/Black			1/2" TURNER MOTOR TO BX TURNER MOTOR		
1/2" Low Pressure Hydraulic Hoses					
Plain			1/2" 2-SPEED FLOW CONTROL TO TANK		
3/4" Low Pressure Hydraulic Hoses					
Plain	35"	35"	3/4" LOW PRESSURE VALVE TO FILTER		
Plain	35"	35"	3/4" LOW PRESSURE TANK TO PUMP		

SECTION 9 MISCELLENEOUS

9.1 Lube System

LT300Rev. A9.05+

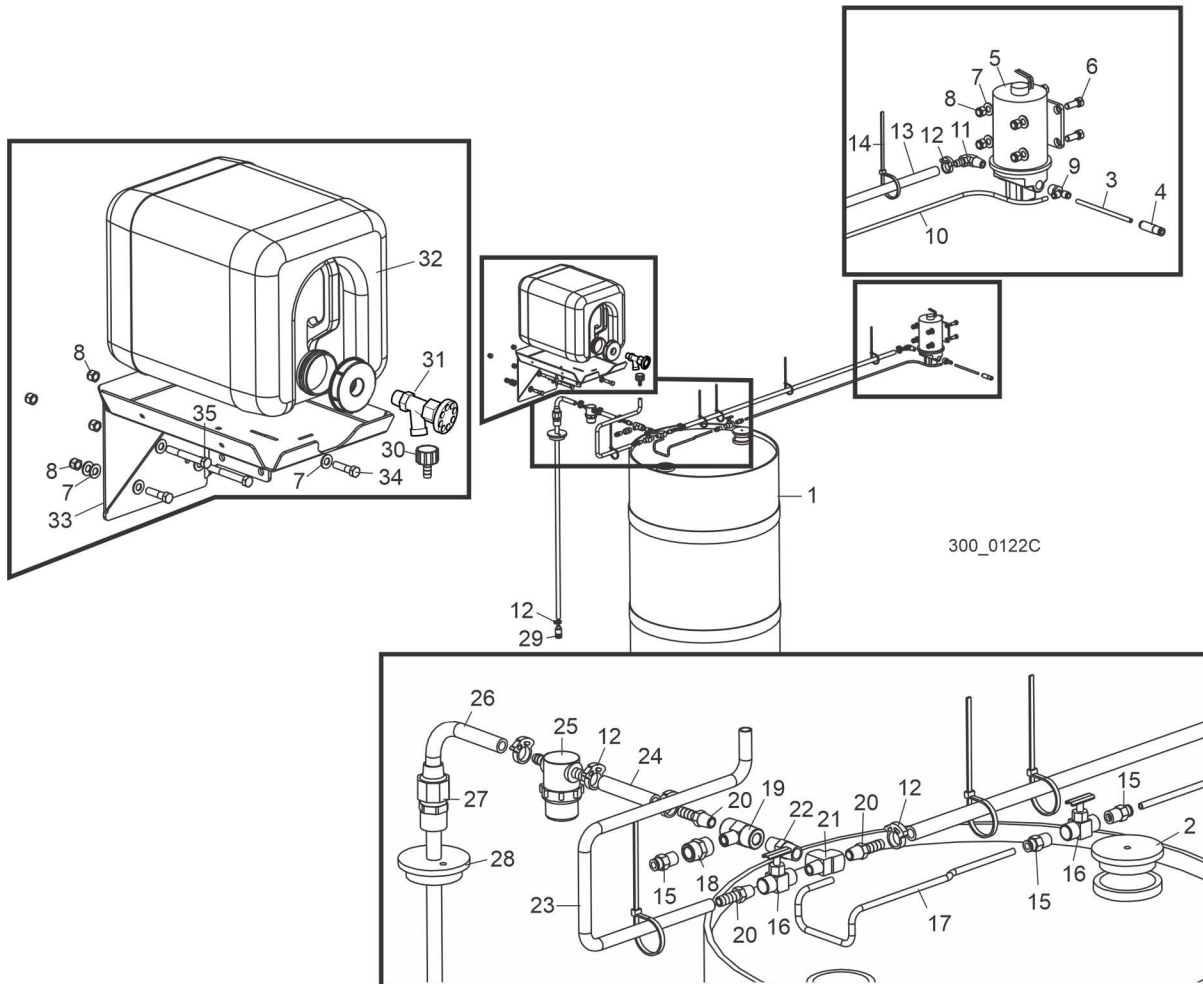

REF	PART #	DESCRIPTION	COMMENTS	QTY.
	016926	LUBE SYSTEM, BLADE		1
1	016784	Barrel, Plastic		1
2	016786	Cap, Barrel Vent		1

9 **Miscellaneous**
Lube System

REF	PART #	DESCRIPTION	COMMENTS	QTY.
3	074018	Tube, 1/4" x 100 Ft. Chainflex Pressure	Replaces 016944 1/4" x 107 Ft. Hose (WM3500 Rev. B7.00+). Additional 6 foot of hose supplied for LT300-BX6WM3000-BX6WM3500-BX6. Additional 10 foot of hose supplied for LT300-BX10WM3000-BX10.	1
4	016827	Fitting, 1/4" Tube 6 PSI Check Valve		1
	025249	Cable Assembly, Lube Power		1
	016883	Pump Assembly, Lube		1
5	050029	Pump Assembly, Lube w/Wires		1
6	F05007-87	Bolt, 3/8-16 x 1" Hex Head Grade 5		4
7	F05011-3	Washer, 3/8" Flat		10
8	F05010-10	Nut, 3/8-16 Hex Nylon Lock		8
9	016961	Fitting, 3/8" NPT x 1/4" Tube Male Run Tee		1
10	016885	Hose, 1/4" x 40"		1
11	P12708	Fitting, 3/8" NPT x 3/8" Hose Barb Elbow		1
12	016845	Clamp, Single Snap Grip #38		6
13	016829	Hose, 3/8" x 44"		1
14	F05089-3	Tie Wrap, 3/16" x 5 1/2" UV Black		6
15	P20903	Fitting, 1/4" NPT x 1/4" Tube Straight		3
16	051392	Valve, 1/4" NPT Female Needle		2
17	016886	Hose, 1/4" x 24"		1
18	P03420	Fitting, 1/4" NPT Coupling		1
19	015486	Fitting, 1/4" NPT Branch Tee		1
20	014685	Fitting, 1/4" NPT x 3/8" Hose Barb		3
21	P05382	Fitting, 1/4" NPT Male x 1/4" Female x 2		1
22	P21524	Fitting, 1/4" NPT Nipple		1
23	038495	Hose, 3/8" ID x 25" Tygothane		1
24	038494	Hose, 3/8" x 3"		1
25	033447	Filter, 3/8" Hose Barb Lube		1
	033441	Screen Kit, Mesh Filter		1
	061768	Gasket, Filter Bowl		1
	003198	Bowl, LubeMizer Filter Replacement		1
26	016884	Hose, 3/8" x 40"		1
27	016935	Fitting, 1/2" x 1/2" Compression Coupler		1
28	016785	Cap, Barrel Vent		1
29	016939	Fitting, 3/8" Barb Foot Check Valve		1
30	014113	Fitting, 5/8" NPT x 3/8" Hose Barb		1
31	133320	Valve, 3/4 NPT Elbow 3/4 Male GHT Outlet	Replaced 014100 after 9/19/2024 per ECN 38718.	1
	014100	Valve, 3/4" NPT Elbow PVC		1
	014636	Fitting, 3/4" FPT x 3/4" MPT	Deleted after 9/19/2024 per ECN 38718.	1

REF	PART #	DESCRIPTION	COMMENTS	QTY.
32	014642	Bottle Assembly, Water Lube w/Cap	Use Water Bottle Assembly w/Cap 014642 to service all bottle/cap combinations previously supplied. Bottle 014367, 61mm Cap 014773 and 70mm Cap 036744 no longer available separately.	1
	061372	O-ring, Water Bottle Cap	If the water bottle cap keeps leaking, add this o-ring to the cap. Leave the existing o-ring installed.	1
33	038498	Bracket, Auxiliary Tank Mount		1
34	F05007-78	Bolt, 3/8-16 x 1 1/2" Hex Head Grade 5		2
35	F05007-73	Bolt, 3/16 x 3" Hex Head Grade 5		2

9.2 Tools

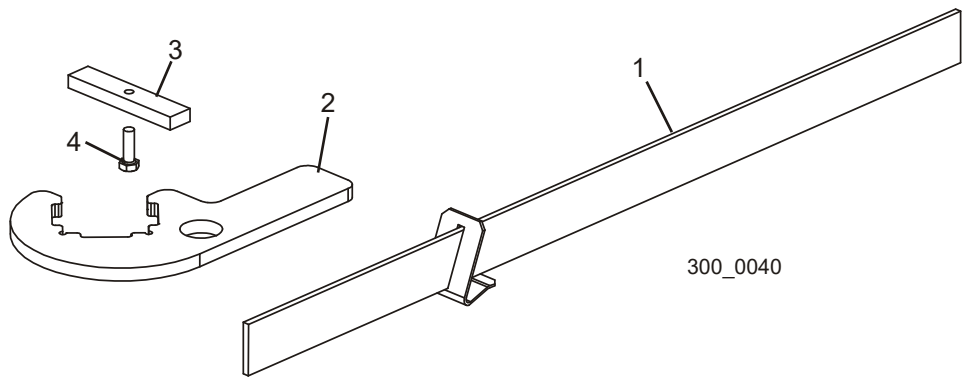

REF	DESCRIPTION (◆ Indicates Parts Available In Assemblies Only)	PART #	QTY.
1	ALIGNMENT TOOL, BLADE GUIDE	LTBGAT	1
2	ALIGNMENT TOOL, BLADE GUIDE ARM	042700	1
3	BLOCK, BLADE GUIDE ALIGNMENT	035799	2
4	BOLT, #10-32 X 5/8" HEX HEAD	F05004-152	2
	HONE, 6" COURSE DIAMOND BENCH SHARPENING (NOT SHOWN)	017813	1

9.3 Manuals



REF	DESCRIPTION (◆ Indicates Parts Available In Assemblies Only)	PART #	QTY.	
WM3500 Manuals				
1	MANUAL, WM3500 OPERATOR'S	M1637	1	
2	MANUAL, WM3500 PARTS	M1639	1	
Option Manuals				
3	MANUAL, INCLINE CONVEYOR OPTION	M1121	1	
4	MANUAL, TD2 TRANSFER DECK OPTION	M1192	1	
5	MANUAL, LD12/LD20 LOG INFEED DECK OPTION	M1120	1	
6	MANUAL, THREE-WAY DECK OPTION	M1208	1	
7	MANUAL, DEBARKER OPTION	M1264	1	
Schematics				
8	SCHEMATIC, WM3000 ELECTRICAL	M1014	1	
9	SCHEMATIC, WM3500 AIR	M1015	1	

9.4 Electrical Harnesses/Cables

Description	Model	Part No.	Qty.
Main Electrical Box			
Harness Assembly, Power Feed	w/o Pantograph	050975-1-BXP	1
	w/Pantograph	050975-1-BXP	1
	BX6 w/o Pantograph	050975-1-BXP	1
	BX6 w/Pantograph	050975-1-BXP	1
Harness Assembly, Up/Down	w/o Pantograph	050976-1-BXP	1
	w/Pantograph	050976-1-BXP	1
	BX6 w/o Pantograph	050976-1-BXP	1
	BX6 w/Pantograph	050976-1-BXP	1
Harness Assembly, Up/Dn Brake	w/o Pantograph	050977-BXP	1
	w/Pantograph	050977-BXP	1
	BX6 w/o Pantograph	050977-BXP	1
	BX6 w/Pantograph	050977-BXP	1
Harness Assembly, 25HP Motor	w/o Pantograph	052914-BXP	1
	w/Pantograph	052914-BXP	1
	BX6 w/o Pantograph	052914-BX	1
	BX6 w/Pantograph	052914-BXP	1
Harness Kit, Blade Motor Therm	All	068202	1
Harness Assembly, Hydraulic Pump	All	053685	1
Cable, Hydraulic Valve Solenoid	All	024923	17
Cable Assembly, Right Joystick	All	025184	1
Cable Assembly, Left Joystick	All	025185	1
Harness Assembly, Head Box	w/o Pantograph	052913-BXP	1
	w/Pantograph	052913-BXP	1
	BX6 w/o Pantograph	052913-BX	1
	BX6 w/Pantograph	052913-BXP	1
Head Box			
Cable, Blade Brake Release Solenoid	All	025233	1
Cable, Blowoff Valve Solenoid	All	024923	1
Harness Assembly, Blade Guide	All	025284	1
Harness Assembly, Blade Break Prox	All	025286	1
Harness Assembly, Feed Start Prox	All	025287	1
Harness Assembly, Feed Slow Prox	All	025288	1
Harness Assembly, Feed Stop Prox	All	025289	1

WM3500 Bed			
Cable Assembly, Transducer	w/o Pantograph	050974	1
	w/Pantograph	050974	1
	BX6 w/o Pantograph	050981	1
	BX6 w/Pantograph	078192	1
Cable, Up/Down Ballscrew Prox	All	025120	1

9.5 Pantograph Assembly

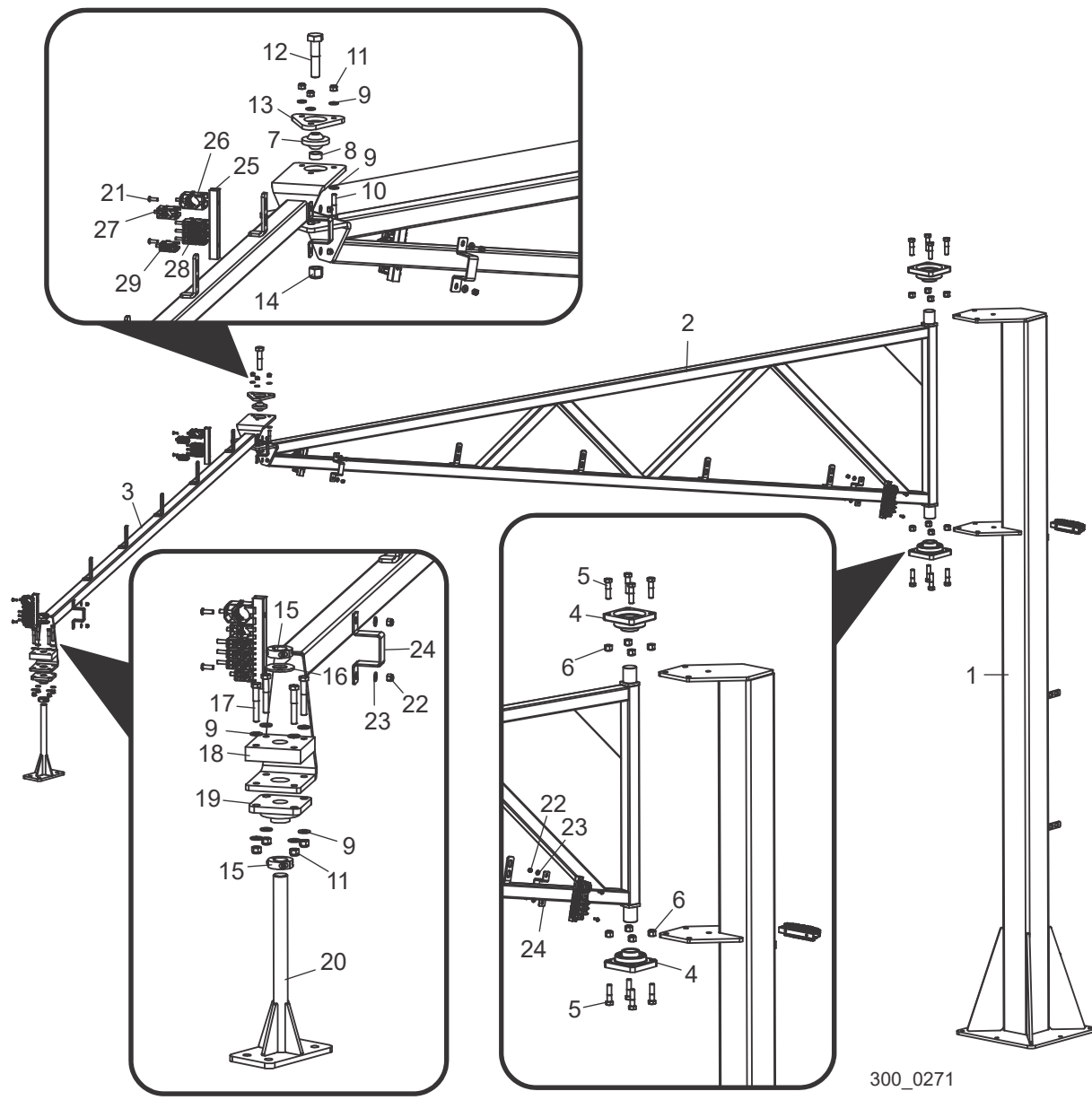

REF	DESCRIPTION (◆ Indicates Parts Available In Assemblies Only)	PART #	QTY.
	PANTOGRAPH RETROFIT, OVERHEAD CABLE	006767	1
	Pantograph Assembly, Overhead Cable	074149	1
1	Post Weldment, Pantograph Main	074002	1
2	Arm Weldment, Pantograph A-Frame Swing	074000	1
3	Arm Weldment, Pantograph Connector	074001	1
	Bolt, 1/2" x 5 1/2" Concrete Wedge Anchor	F05008-131	8

4	Bearing, 1 15/16" 4-Bolt Flange	033712	2
5	Bolt, 5/8-11 x 2 1/2" Hex Head Grade 5	F05009-20	8
6	Nut, 5/8-11 Hex Nylon Lock	F05010-34	8
7	Ball Joint, 3/4" ID x 2 1/2" OD	042538	1
8	Spacer, 25/32" 1 1/8" x 1/2"	057913	1
9	Washer, 3/8" SAE Flat	F05011-3	14
10	Bolt, 3/8-16 x 2" Hex Head Grade 8	F05007-124	3
11	Nut, 3/8-16 Hex Nylon Lock	F05010-10	7
12	Bolt, 3/4-10 x 3 1/2" Hex Head Grade 5	F05009-54	1
13	Plate, Ball Joint Retainer	057912	1
14	Nut, 3/4-10 Hex Nylon Lock	F05010-103	1
15	Collar, 1" Lock	038444	2
16	Washer, 1" SAE Flat	F05011-28	1
17	Bolt, 3/8-16 x 2 1/2" Hex Head Grade 5	F05007-125	4
18	Block, Bearing Mount	057910	1
19	Bearing, VF4S-216 Flanged	014090	1
20	Bracket Weldment, LT300 Pantograph Pivot	057481	1
21	Screw, 1/4-20 x 3/4" SBHC	F05005-60	8
22	Nut, 1/4-20 Nylock	F05010-69	8
23	Washer, 1/4" SAE Flat	F05011-11	8
24	Plate, Strain Relief Mount	074004	4
	Relief Assembly, WM3000/3500 Strain	074148	5
25	Rail, CFX Strain Relief Profile	065979	1
26	Strain Relief, CFX 26-30mm Single Cable	074147	1
27	Strain Relief, CFX 18-20mm Single Cable	065976	1
28	Strain Relief, CFX 6-12mm Double Cable	065977	3
29	Strain Relief, CFX 12-14mm Single Cable	065978	1
	Tie Wrap, 5/16" x 15" UV Black	F05089-5	20
	Tie Wrap, 3/16" x 6" UV Black	F05089-3	10
	Harness Kit, Pantograph Retrofit	053298	1
	Harness Assembly, Power Feed	050975-1-BXP	1
	Harness Assembly, Up/Down	050976-1-BXP	1
	Harness Assembly, Up/Down Brake	050977-BXP	1
	Bolt, 1/2-13 x 1 1/2" Hex Head Grade 5	F05008-33	4
	Instructions, Pantograph Retrofit	006767-1579	1

SECTION 10 OPERATOR STATION

10.1 Frame, Rails & Ladder

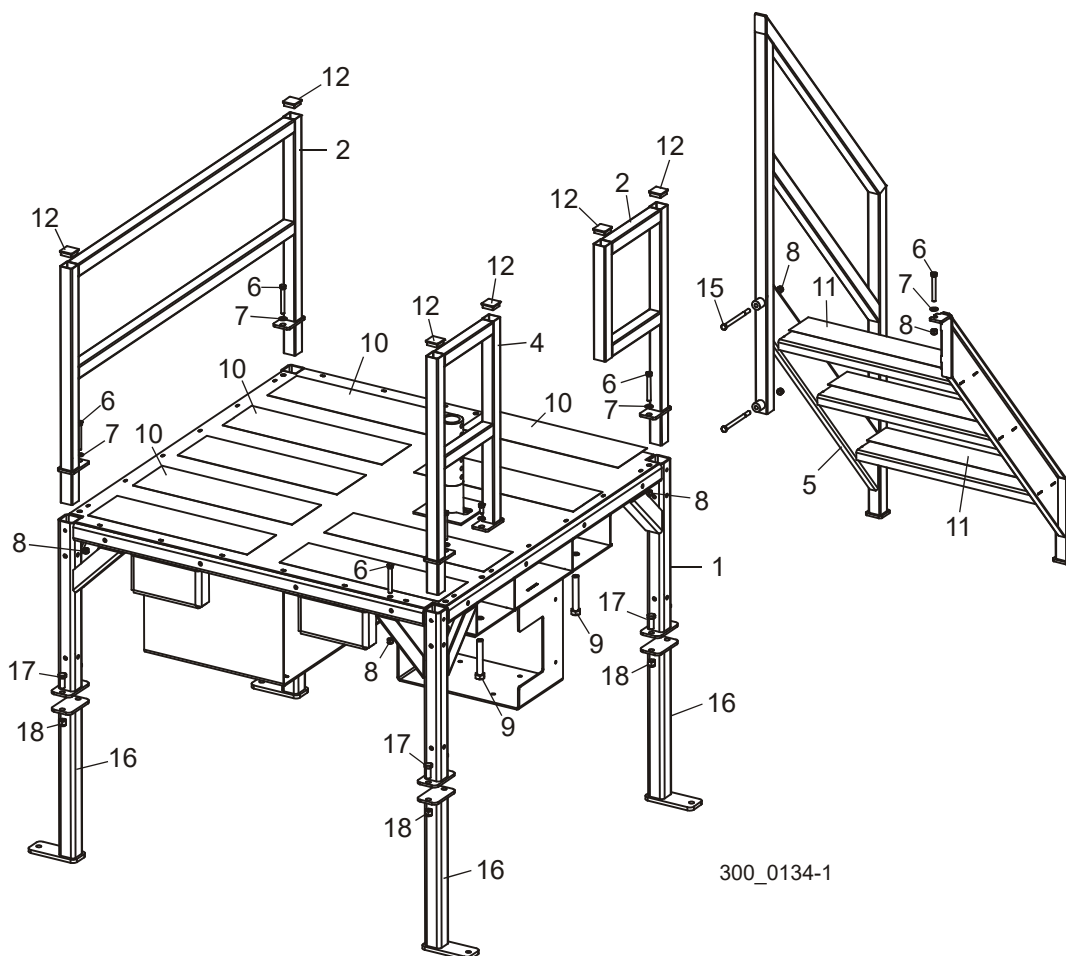

REF	DESCRIPTION (◆ Indicates Parts Available In Assemblies Only)	PART #	QTY.
1	FRAME WELDMENT, OPERATOR STATION	038893	1
2	RAIL WELDMENT, LONG	045118	1
3	RAIL WELDMENT, SHORT	045119	1
4	RAIL WELDMENT, LEFT REAR	036360	1
5	LADDER WELDMENT, OPERATOR STATION	036474	1
6	BOLT, 3/8-16 X 3" HEX HEAD FULL THREAD	F05007-1	6
7	WASHER, 3/8" SAE FLAT	F05011-3	5
8	NUT, 3/8-16 HEX NYLON LOCK	F05010-10	8
9	BOLT, 5/8-11 X 4" HEX HEAD FULL THREAD GRADE 5	F05009-8	2

10	PAD, NON-SKID	045149	15 Ft.	
11	PAD, NON-SKID STEP	016895	3	
12	PLUG, 1 1/2" SQUARE 14 GA. WALL CAP	016843	6	
13	WASHER, 3/8" SPLIT LOCK	F05011-4	1	
14	BOLT, 3/8-16 X 3/4" HEX HEAD GRADE 5	F05007-118	1	
15	BOLT, 3/8-16 X 5" HEX HEAD GRADE 5	F05007-86	2	
	LEG ASSEMBLY, 18" EXTENSION	036461	4	
16	Leg Weldment, Operator Station 18" Extension	051353	1	
17	Bolt, 1/2-13 x 1 1/4" Hex Head Grade 5	F05008-37	2	
18	Nut, 1/2-13 Hex Nylon Lock	F05010-8	2	

10.2 Seat & Joystick Controls

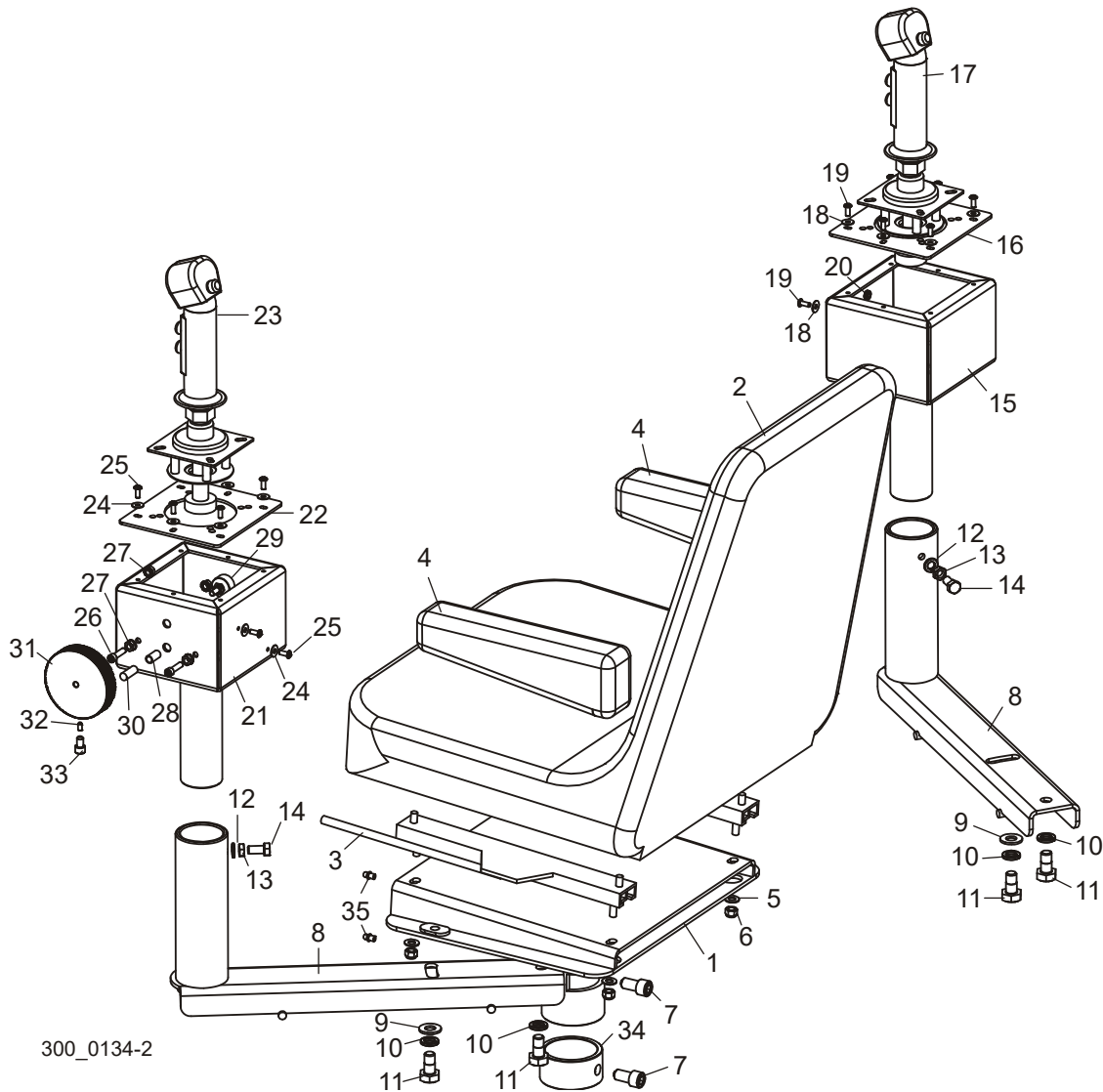

REF	DESCRIPTION (◆ Indicates Parts Available In Assemblies Only)	PART #	QTY.
1	MOUNT WELDMENT, OPERATOR SEAT	045134	1
2	SEAT, OPERATOR	038719	1
3	ADJUSTER ASSEMBLY, OPERATOR SEAT (MILSCO)	038720	1
4	ARMREST, OPERATOR SEAT (PAIR, MILSCO)	038721	1
5	WASHER, 5/16" SAE FLAT	F05011-17	4
6	NUT, 5/16-18 NYLON LOCK	F05010-58	4
7	BOLT, 1/2-20 X 1" SOCKET HEAD	F05008-57	2
8	ARM WELDMENT, CONTROL	038857	2
9	WASHER, 1/2" SAE FLAT	F05011-2	2

10	WASHER, 1/2" SPLIT LOCK	F05011-9	4	
11	BOLT, 1/2-13 X 1" HEX HEAD	F05008-50	4	
12	WASHER, 3/8" SPLIT LOCK	F05011-4	2	
13	NUT, 3/8-16 HEX JAM	F05010-29	2	
14	BOLT, 3/8-16 X 3/4" HEX HEAD GRADE 5	F05007-118	2	
	CONTROL ASSEMBLY, RIGHT JOYSTICK	038865	1	
15	Box Weldment, Right Joystick	038863	1	
16	Cover, Joystick Control Box	038861	1	
17	Joystick, 3-Button Control	036757	1	
	Button, Joystick Press	061192	1	
18	Washer, #10 SAE Flat	F05011-18	7	
19	Screw, #10-24 x 1/2" Socket Button Head	F05004-35	7	
20	Nut, #10-24 Self-Locking Hex	F05010-14	1	
	CONTROL ASSEMBLY, LEFT JOYSTICK	038864	1	
21	Box Weldment, Left Joystick	038862	1	
22	Cover, Joystick Control Box	038861	1	
23	Joystick, 3-Button Control	036757	1	
	Button, Joystick Press	061192	1	
24	Washer, #10 SAE Flat	F05011-18	8	
25	Screw, #10-24 x 1/2" Socket Button Head	F05004-35	8	
26	Bolt, 1/4-20 x 1" Socket Head	F05005-84	2	
27	Nut, 1/4-20 Self-Locking Hex	F05010-9	4	
28	Spring, LC-040E-10SS	P06460	1	
29	Potentiometer Assembly, 4-20mA 24V w/Connectors	025200	1	
30	Pin, Cam Brake	S10663	1	
31	Knob, Speed Control	035559	1	
32	Screw, #10-32 x 3/8" Cup Point Socket Set	F05004-188	1	
33	Bolt, 5/16-18 x 1/2" Socket Head	F05006-39	1	
34	COLLAR, SEAT POST MOUNT	045135	1	
35	FITTING, 1/4-28 GREASE	P05060	2	

10.3 Electrical Box Assembly

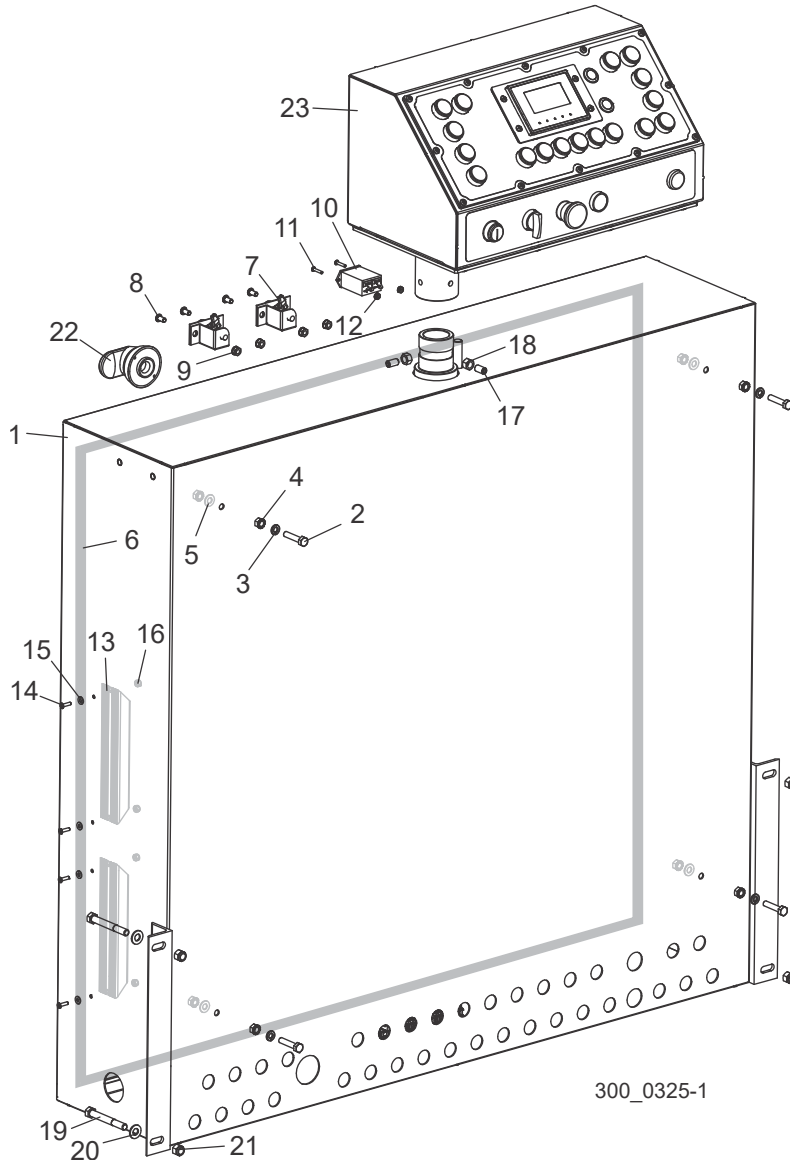

REF	DESCRIPTION (◆ Indicates Parts Available In Assemblies Only)	PART #	QTY.
	ELECTRICAL BOX ASSEMBLY, WM3500 BX	053687-BX	1
1	Box Weldment, Electrical	035358	1
2	Bolt, 5/16-18x1 1/2 HH GR5 FT	F05006-76	4
3	Washer, 5/16 Split Lock	F05011-13	4
4	Nut, 5/16-18 Keps	F05010-20	8
	Panel Assembly, WM3500 Insert (<i>See Form #1639 WM3500 Electrical Information for parts</i>)	053686	1
5	Washer, 5/16 SAE Flat	F05011-17	4

6	Foam, 3/16x1/2 Adhesive Back Rubber (ft.)	R02309	18	
7	Latch, Electric Box Door	P20048	4	
8	Screw, 1/4-20x1/2 BHSC SS Gr2	F05005-112	8	
9	Nut, 1/4-20 Keps	F05010-9	8	
10	Digital Meter, Hour Rect Mount w/ Gasket	015401	1	
11	Screw, 6-32x3/4 SBHC SS	F05004-93	2	
12	Nut, #6-32 Keps	F05010-59	2	
13	Resistor, 150ohm 150W 5% Non-Ind Cement	052098	2	
14	Screw, 8-32x5/8 SBHC, Stainless Steel	F05004-98	4	
15	Washer, #8 SAE Flat	F05011-41	4	
16	Nut, #8-32 Hex Nylock	F05010-169	4	
17	Screw, 3/8-16x3/4 SHFP Set SS	F05007-166	2	
18	Nut, 3/8-16 Hex	F05010-1	2	
19	Bolt, 3/8-16x3 HH Gr5	F05007-73	4	
20	Washer, 3/8 Flat SAE	F05011-3	4	
21	Nut, 3/8-16 Hex Nyloc	F05010-10	4	
22	Handle, Disconnect RED/TEL Pistol-6mm	050907-1	1	
23	Operator Interface Box Assembly (<i>See Form #1639 WM3500 Electrical Information for parts</i>)	024967	1	
	Harness Assembly, BX Pantograph PF	050975-1-BXP	1	
	Harness Assembly, BX Pantograph UD	050976-1-BXP	1	
	Harness Assembly, BX Pantograph UD Brk	050977-BXP	1	
	Harness Assembly, BXP 25HP Motor 2007	052914-BXP	1	
	Harness Assembly, WM3500 Hyd Pump Rev1	053685	1	
	Cable, 5M Form A Din 24Vdc W/LED PUR	024923	18	
	Cable Assembly, Right Joystick	025184	1	
	Cable Assembly, Left Joystick	025185	1	
	Harness Assembly, BXP Head Box 2007	052913-BXP	1	
	Foot Switch Assembly, WM3500 2-Spd Hyd	053689	1	

10.4 Air Supply

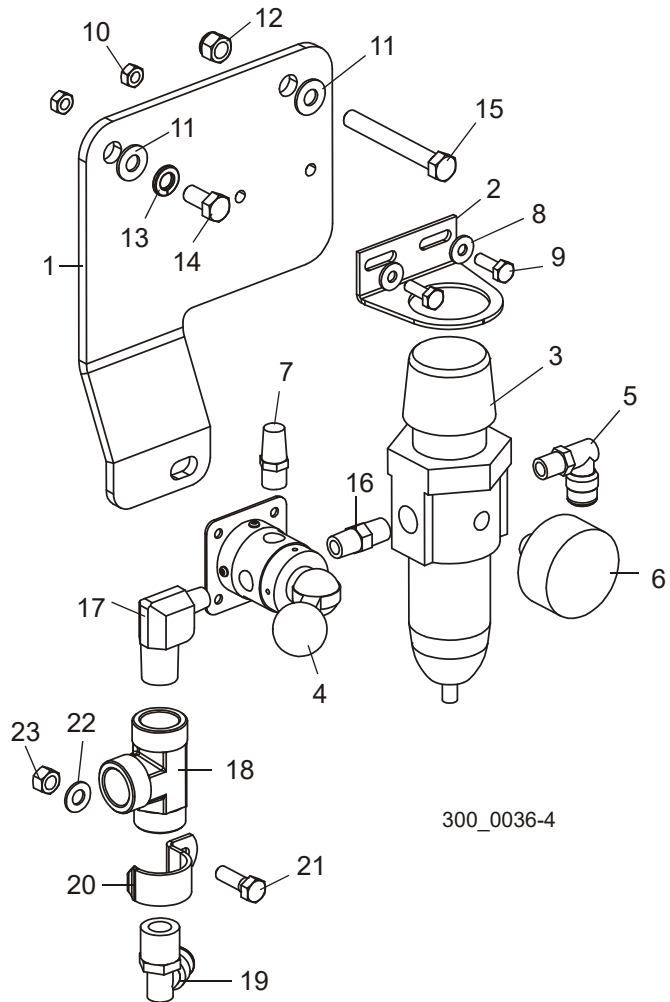

REF	DESCRIPTION (◆ Indicates Parts Available In Assemblies Only)	PART #	QTY.
	AIR SUPPLY, WM3500	016887	1
1	Plate, Air Supply Mount	016888	1
2	Bracket, Air Filter Mount	P21511	1
3	Filter, B11-02 WJC Regulator	P21510	1
4	Valve, 250V3 Air	P21513	1
5	Fitting, 1/4" NPT x 3/8" Air 90° Elbow	P21521	1
6	Gauge, Air Pressure	P21512	1
7	Fitting, 1/4" NPT Air Muffler	P20904	1
8	Washer, 1/4" SAE Flat	F05011-11	2
9	Bolt, 1/4-20 x 3/4" Hex Head Full Thread	F05005-1	2
10	Nut, 1/4-20 Hex Lock	F05010-21	2
11	Washer, 3/8" SAE Flat	F05011-3	2

12	Nut, 3/8-16 Nylon Lock	F05010-10	1	
13	Washer, 3/8" Split Lock	F05011-4	1	
14	Bolt, 3/8-16 x 3/4" Hex Head Grade 5	F05007-118	1	
15	Bolt, 3/8-16 x 3" Hex Head Full Thread	F05007-1	1	
16	Fitting, 1/4" Hex Pipe Nipple	P05389	1	
17	Fitting, 1/2" NPT x 1/4" NPT 90° Elbow	016881	1	
18	Fitting, 1/2" NPT Female Tee	016793	1	
19	Fitting, 1/2" NPT x 1/2" Air 90° Elbow	016880	1	
20	Clamp, 1" EMT	P05436	1	
21	Bolt, 5/16-18 x 1" Hex Head	F05006-1	1	
22	Washer, 5/16" SAE Flat	F05011-17	1	
23	Nut, 5/16-18 Hex Lock	F05010-6	1	

SECTION 11 PRESSURE LUBE OPTION

11.1 Pressure Lube System

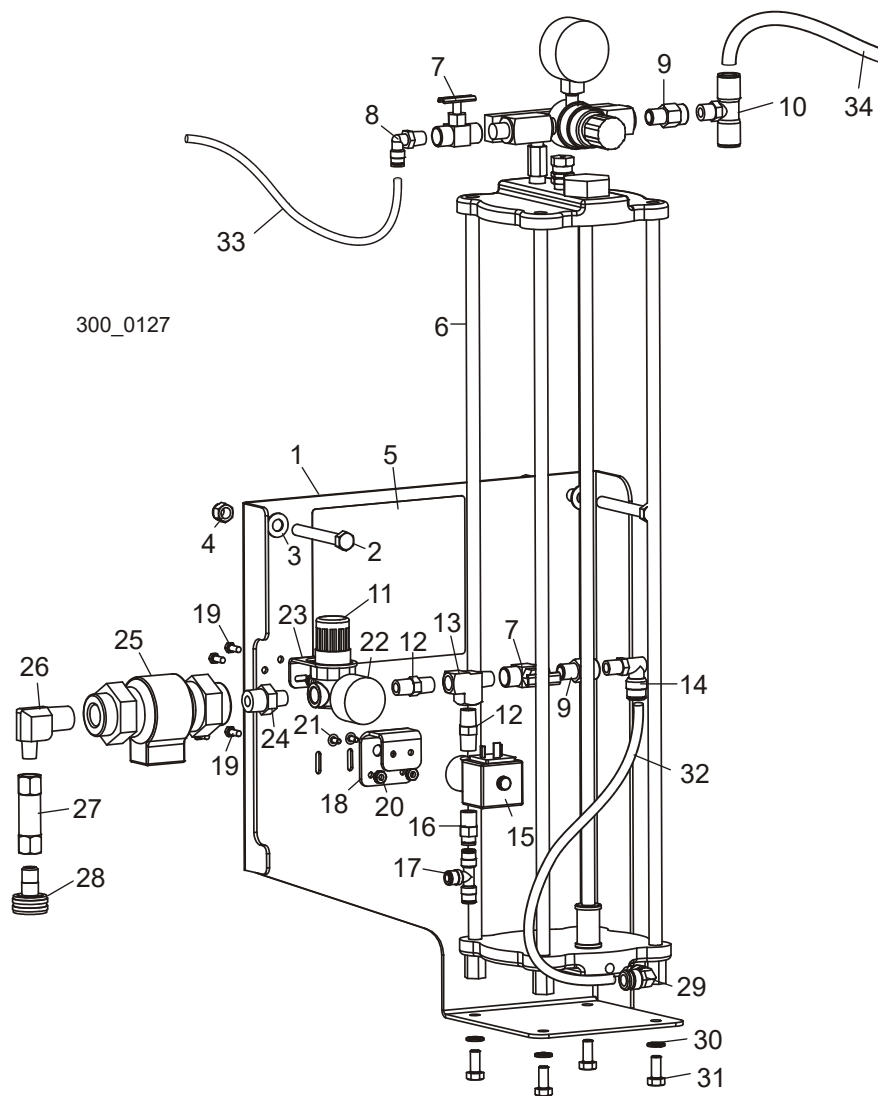

REF	DESCRIPTION (◆ Indicates Parts Available In Assemblies Only)	PART #	QTY.
	LUBE SYSTEM, LT300 OPTIONAL PRESSURE BLADE	051431-A	1
1	Bracket, Pressure Lube Mount	036685	1
2	Bolt, 3/8-16 x 3" Hex Head Full Thread	F05007-1	2
3	Washer, 3/8" SAE Flat	F05011-3	2
4	Nut, 3/8-16 Hex Nylon Lock	F05010-10	2
5	Decal, Pressure Lube Layout	036747	1
6	Reservoir Assembly, Pressure Lube	051434	1

7	Valve, 1/4" NPT Brass Female Needle	051392	2	
8	Fitting, 1/4" NPT x 1/4" Tube 90° Elbow Air	P21519	1	
9	Valve, 1/4" NPT Male-Female Check	051394	2	
10	Fitting, 1/4" NPT x 1/2" Tube Tee	038737	1	
11	Regulator, 1/4" NPT 125 PSI Water	051427	1	
12	Fitting, 1/4" NPT Hex Pipe Nipple	P05389	2	
13	Fitting, 1/4" NPT Female-Male-Female Tee	P05382	1	
14	Fitting, 1/4" NPT x 3/8" Tube 90° Elbow Air	P21521	1	
15	Valve, 1/4" NPT Water NC 2-Way Solenoid	051432	1	
	Cable Assembly, LT300 Lube Pump	052222	1	
16	Fitting, 1/4" NPT x 1/4" Tube Straight Air	P20903	1	
17	Fitting, 1/4" Tube Air Tee	P21544	1	
18	Bracket, Solenoid Mount	036688	1	
19	Screw, #10-24 x 1/2" Unslotted Hex Stainless Steel	F05004-27	4	
20	Nut, #10-24 Self-Locking Hex	F05010-14	4	
21	Screw, #8-32 x 3/8" Round Head Grade 5	F05004-157	2	
22	Gauge, 160 PSI	P02766	1	
23	Bracket, Regulator Mount	051429	1	
24	Fitting, 1/2" NPT x 1/4" NPT Hex Nipple	038484	1	
25	Valve, 1/2" NPT Vacuum Break Dual Check	038483	1	
26	Fitting, 1/2" NPT x 1/4" NPT 90° Elbow	016881	1	
27	Strainer, 1/4" NPT 100 Mesh Inline	051882	1	
28	Fitting, 1/4" NPT x Female Water Hose	051433	1	
29	Fitting, 1/8" NPT x 3/8" Tube 90° Elbow	P21552	1	
30	Washer, 5/16" Split Lock	F05011-13	4	
31	Bolt, 5/16-24 x 3/4" Hex Head Grade 5 Full Thread	F05006-105	4	
32	Tubing, 3/8" Chainflex Air	R01869-4	3 ft.	
33	Tubing, 1/4" Chainflex Air	R01869-3	2 ft.	
34	Tubing, 1/2" Chainflex Air	R01869-5	3 ft.	

SECTION 12 CAB OPTION

12.1 Cab

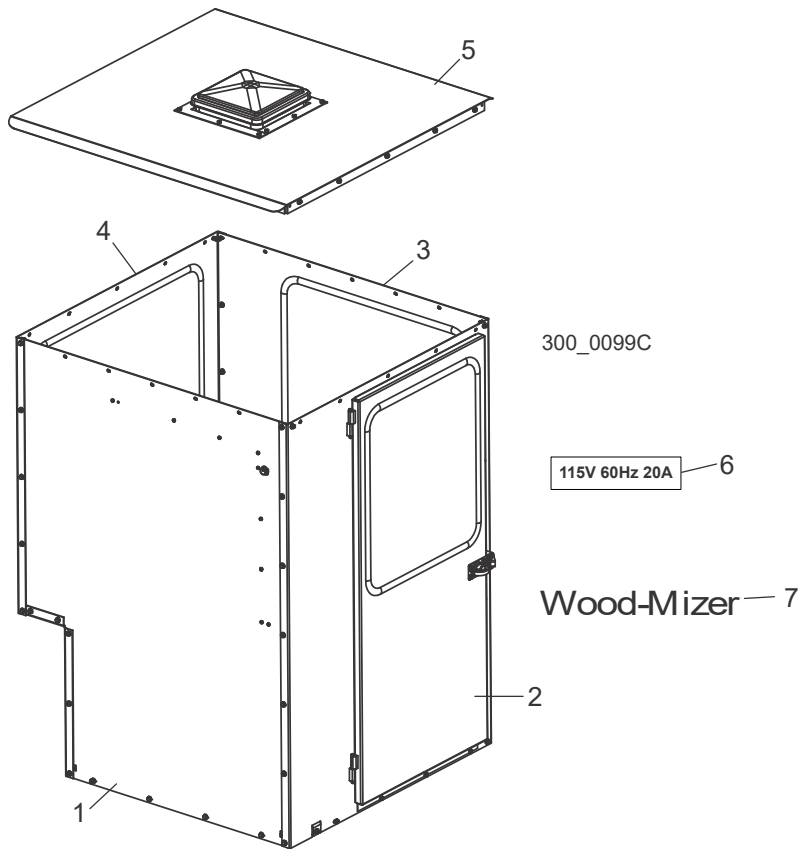

REF	DESCRIPTION (◆ Indicates Parts Available In Assemblies Only)	PART #	QTY.
	CAB OPTION, WM3500	CAB2	1
1	Rear Panel Parts (See Section 12.2)		
2	Right Panel Parts (See Section 12.3)		
3	Front Panel Parts (See Section 12.4)		
4	Left Panel Parts (See Section 12.5)		
5	Roof Parts (See Section 12.6)		
6	Decal, Cab Voltage	042676	1
7	Decal, Wood-Mizer Logo 15"	052281	1

12.2 Rear Panel

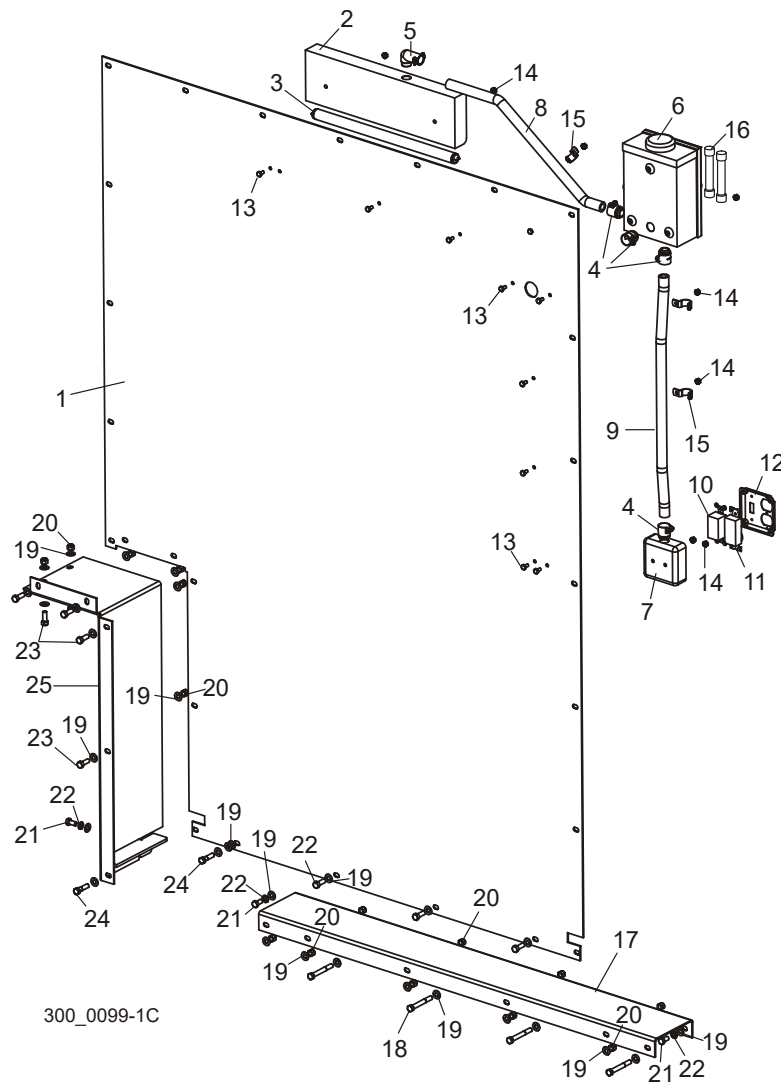

REF	DESCRIPTION (◆ Indicates Parts Available In Assemblies Only)	PART #	QTY.	
	PANEL ASSEMBLY, CAB2 REAR	036602	1	
1	Panel, Cab2 Rear	036601	1	
2	Fixture, Flourescent Uncer-Cabinet Light	042590	1	
3	Bulb, 15 Watt Flourescent	016876	1	
4	Clamp, 1/2" Flex Conduit	042595	5	
5	Clamp, 1/2" 90° Flex Conduit	017801	1	
6	Disconnect Switch, 30A Nema 3R Safety	069553	1	
	Ground Bar Kit, Safety Switch (Optional)	069554	1	
7	Box, 4" Electrical Utility	042591	1	
8	Conduit, 1/2" x 21" Steel Flex	042597	1	

12

Cab Option

Rear Panel

9	Conduit, 1/2" x 25" Steel Flex	042596	1	
10	Switch, 120VAC 20 Amp Single Pole	042592	1	
11	Receptacle, 120VAC 20 Amp Duplex	042593	1	
12	Cover, Stainless Steel Switch/Plug	042594	1	
13	Bolt, 1/4-20 x 1/2" Hex Head	F05005-15	9	
14	Nut, 1/4-20 Self-Locking Hex	F05010-9	9	
	Wire Nut, Yellow	016863	6	
15	Clamp, 3/4" EMT	P04851	3	
16	Fuse, 20 Amp 250 Volt	E03743	2	
17	CHANNEL WELDMENT, REAR FLOOR	042628	1	
18	BOLT, 3/8-16 X 3" HEX HEAD GRADE 5	F05007-73	4	
19	WASHER, 3/8" SAE FLAT	F05011-3	31	
20	NUT, 3/8-16 HEX NYLON LOCK	F05010-10	15	
21	BOLT, 3/8-16 X 3/4" HEX HEAD	F05007-27	3	
22	WASHER, 3/16" SPLIT LOCK	F05011-4	3	
23	BOLT, 3/8-16 X 1" HEX HEAD	F05007-7	9	
24	BOLT, 3/8-16 X 1 1/2" HEX HEAD GRADE 5	F05007-78	2	
25	PLATE WELDMENT, LOWER LEFT	036591	1	

12.3 Right Panel

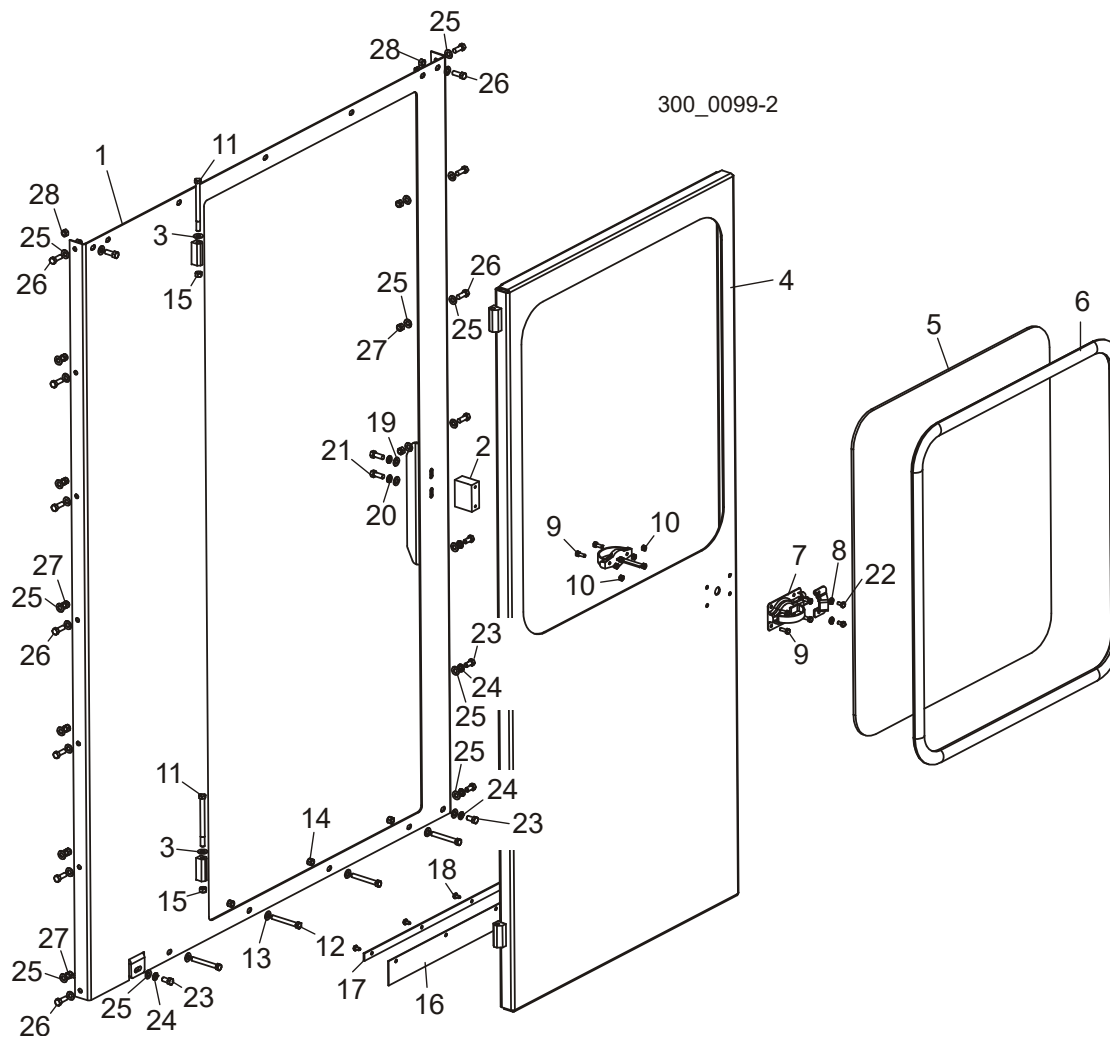

REF	DESCRIPTION (◆ Indicates Parts Available In Assemblies Only)	PART #	QTY.
	PANEL ASSEMBLY, CAB2 RIGHT	036586	1
1	Panel Weldment, Cab2 Right	036585	1
2	Block, Latch Mount	042634	1
3	Washer, Door Hinge	042578	1
4	Door Weldment, Cab	042632	1
5	Window, Cab Door	042576	1
6	Seal, Cab Door Window	042575	1
7	Latch, Door	042587	1
8	Washer, 1/4" Split Lock	F05011-14	2
9	Bolt, 1/4-20 x 3/4" Hex Head Full Thread	F05005-1	6
10	Nut, 1/4-20 Hex Lock	F05010-21	6

12

Cab Option Right Panel

11	Bolt, 3/8-16 x 5" Hex Head Grade 5	F05007-86	2	
12	Bolt, 3/8-16 x 3" Hex Head Full Thread	F05007-1	4	
13	Washer, 3/8" SAE Flat	F05011-3	4	
14	Nut, 3/8-16 Hex Nylon Lock	F05010-10	4	
15	Nut, 3/8-16 Hex Lock	F05010-25	2	
16	Flap, Rubber Door	042638	1	
17	Plate, Rubber Door Flap	042637	1	
18	Screw, 1/4-20 x 1/2" Self-Tapping	F05015-1	5	
19	Washer, 3/8" SAE Flat	F05011-3	2	
20	Washer, 3/8" Split Lock	F05011-4	2	
21	Bolt, 3/8-16 x 1" Hex Head	F05007-7	2	
22	Bolt, 1/4-20 x 1/2" Hex Head	F05005-15	2	
23	BOLT, 3/8-16 X 3/4" HEX HEAD	F05007-27	5	
24	WASHER, 3/8" SPLIT LOCK	F05011-4	5	
25	WASHER, 3/8" SAE FLAT	F05011-3	27	
26	BOLT, 3/8-16 X 1" HEX HEAD	F05007-7	13	
27	NUT, 3/8-16 HEX NYLON LOCK	F05010-10	9	
28	NUT, 3/8-16 HEX LOCK	F05010-25	4	

12.4 Front Panel

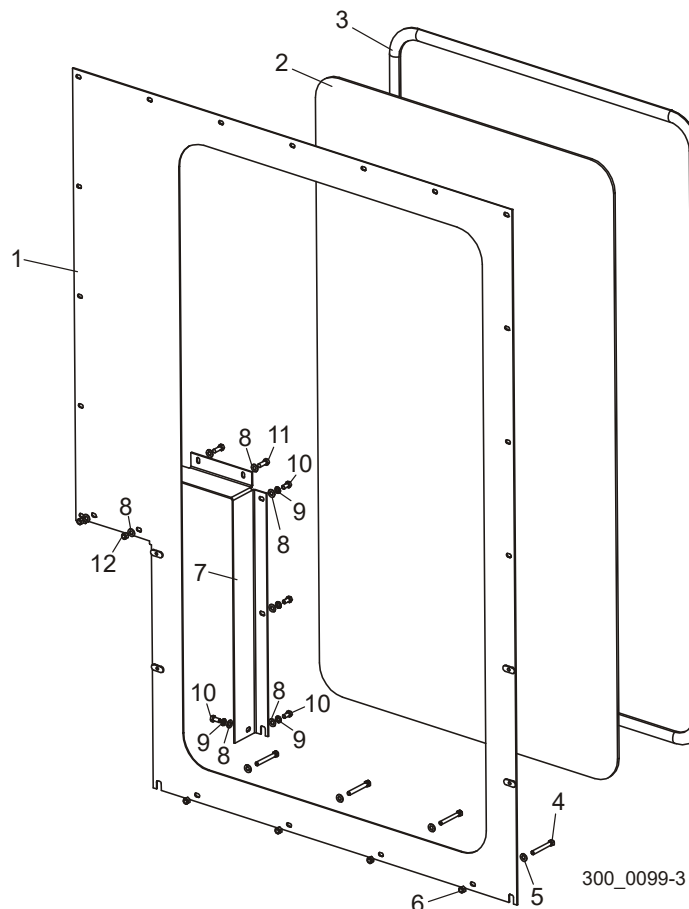

REF	DESCRIPTION (◆ Indicates Parts Available In Assemblies Only)	PART #	QTY.
	PANEL ASSEMBLY, CAB2 FRONT	036605	1
1	Panel Weldment, Cab2 Front	036604	1
2	Window, Cab Front	042631	1
3	Seal, Cab Front Window	042630	1
4	Bolt, 3/8-16 x 3" Hex Head Full Thread	F05007-1	4
5	Washer, 3/8" SAE Flat	F05011-3	4
6	Nut, 3/8-16 Hex Nylon Lock	F05010-10	4
7	PANEL, RIGHT LOWER	036590	1
8	WASHER, 3/8" SAE FLAT	F05011-3	8
9	WASHER, 3/8" SPLIT LOCK	F05011-4	4
10	BOLT, 3/8-16 X 3/4" HEX HEAD	F05007-27	4
11	BOLT, 3/8-16 X 1" HEX HEAD	F05007-7	2
12	NUT, 3/8-16 HEX NYLON LOCK	F05010-10	2

12 Cab Option

Left Panel

12.5 Left Panel

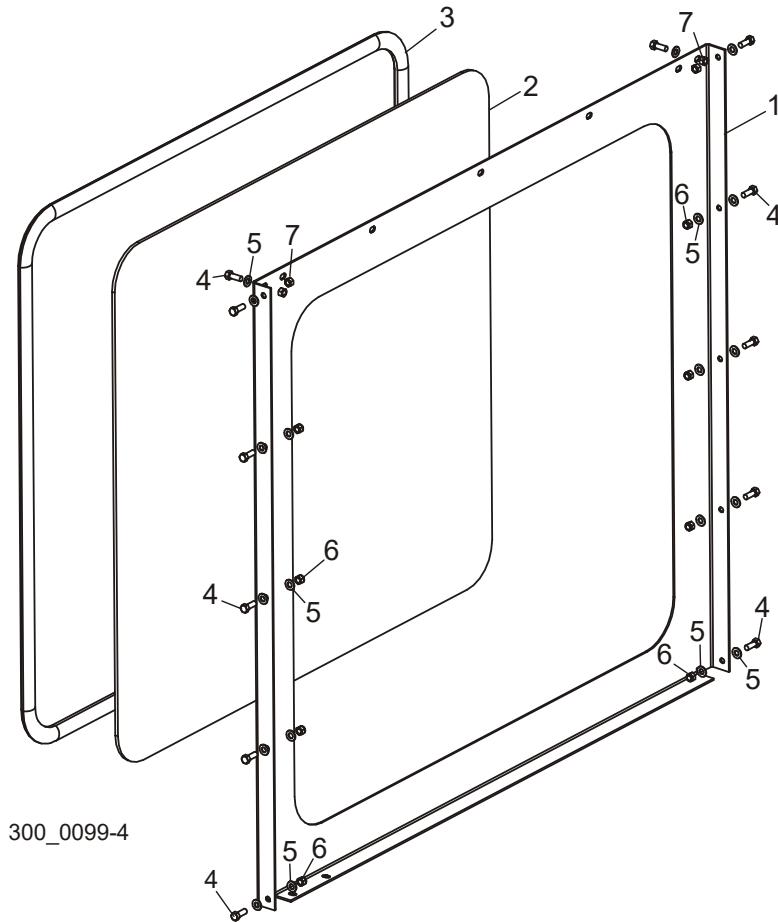

REF	DESCRIPTION (◆ Indicates Parts Available In Assemblies Only)	PART #	QTY.
	PANEL ASSEMBLY, CAB2 LEFT	036588	1
1	Panel, Cab2 Left	036587	1
2	Window, Cab Left	042574	1
3	Seal, Cab Side Window	042573	1
4	BOLT, 3/8-16 X 1" HEX HEAD	F05007-7	12
5	WASHER, 3/8" SAE FLAT	F05011-3	20
6	NUT, 3/8-16 HEX NYLON LOCK	F05010-10	8
7	NUT, 3/8-16 HEX LOCK	F05010-25	4

12.6 Roof

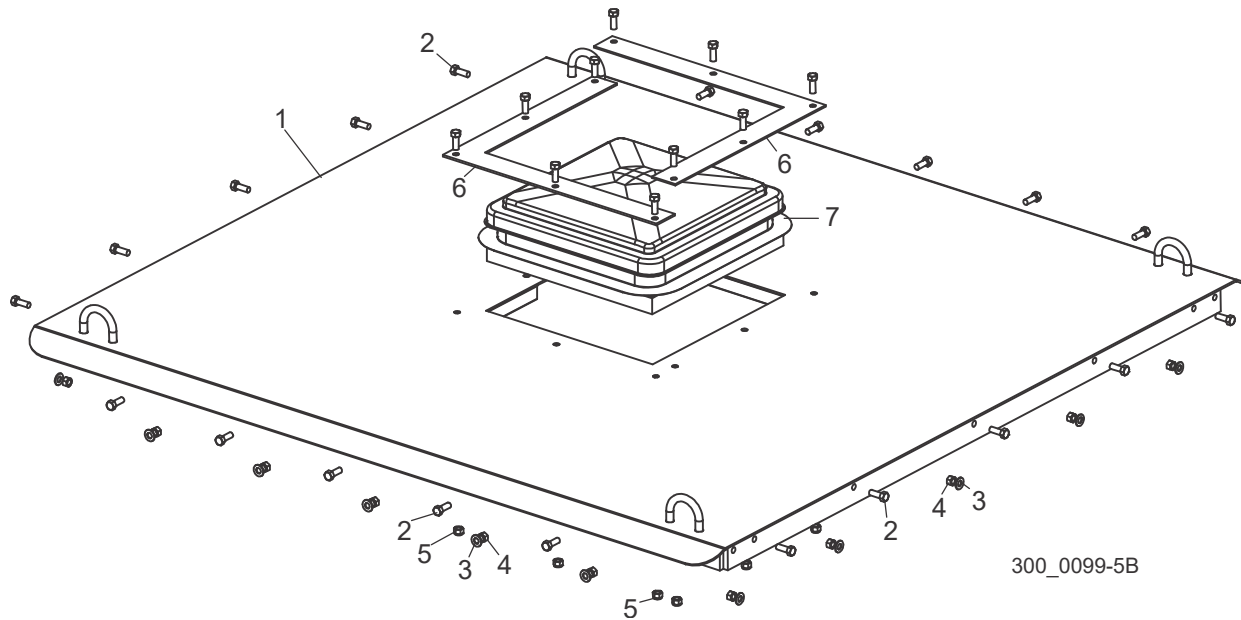

REF	DESCRIPTION (◆ Indicates Parts Available In Assemblies Only)	PART #	QTY.
	ROOF ASSEMBLY, CAB	042635	1
1	Roof Weldment, Cab	042623	1
2	Bolt, 3/8-16 x 1" Hex Head	F05007-7	30
3	Washer, 3/8" SAE Flat	F05011-3	20
4	Nut, 3/8-16 Hex Lock	F05010-25	20
5	Nut, 3/8-16 Hex Nylon Lock	F05010-10	10
6	Plate, Vent Mount	016866	2
7	Vent, Plastic Dome	016867	1

13 Bed Extension

Bed Extension Complete (BX6)

SECTION 13 BED EXTENSION OPTION

13.1 Bed Extension Complete (BX6)¹

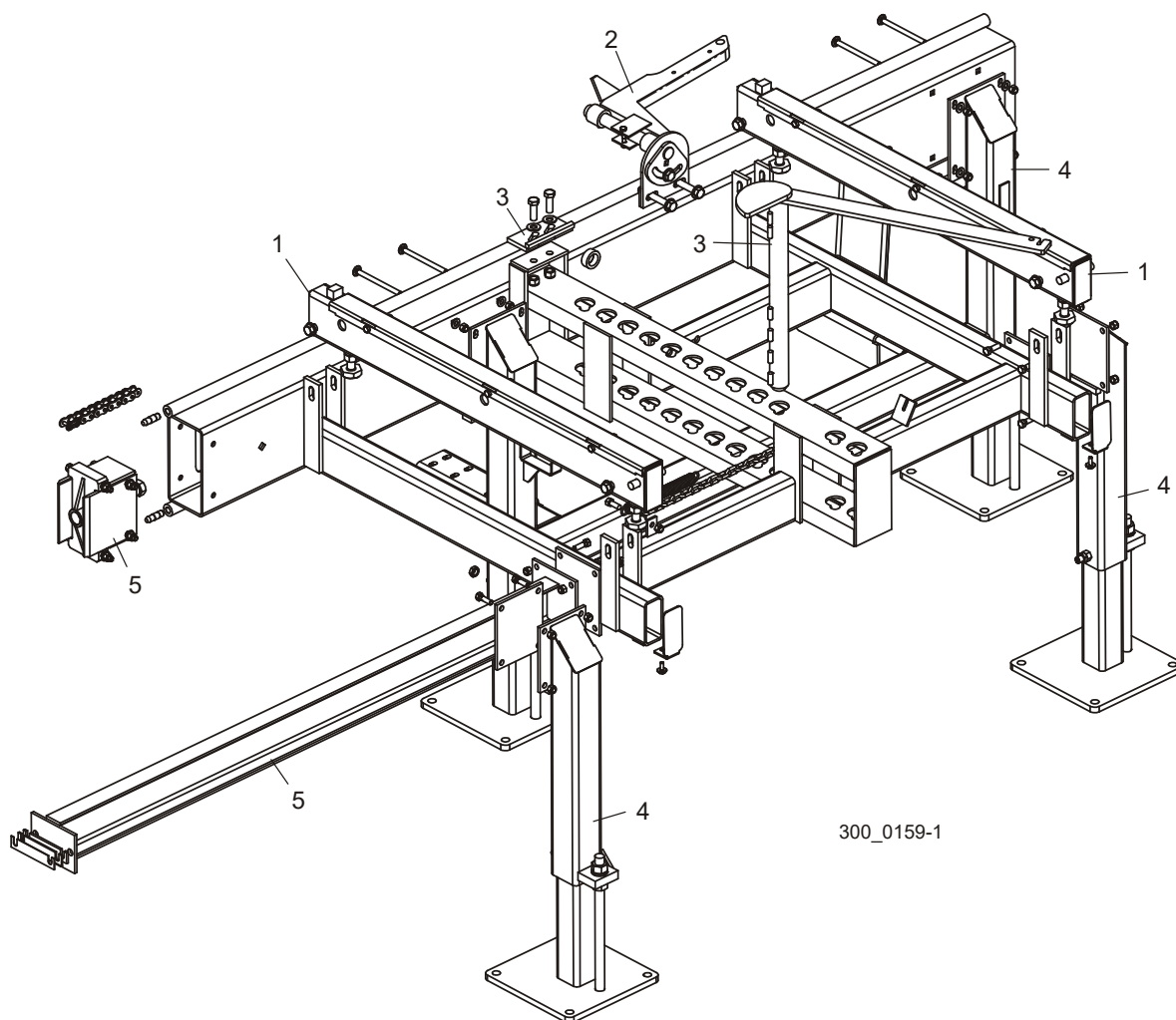

REF	DESCRIPTION (◆ Indicates Parts Available In Assemblies Only)	PART #	QTY.
1	BED RAIL PARTS (See Section 13.2)		
2	SIDE SUPPORT PARTS (See Section 13.5)		
3	MANUAL LOG CLAMP PARTS (See Section 13.3)		
4	LEG PARTS (See Section 13.8)		
5	CONNECTION PARTS (See Section 13.4)		

1. IMPORTANT! Bed Extension Option can only be purchased with the purchase of a new sawmill and may not be added later.

13.2 Bed Rails (BX6)

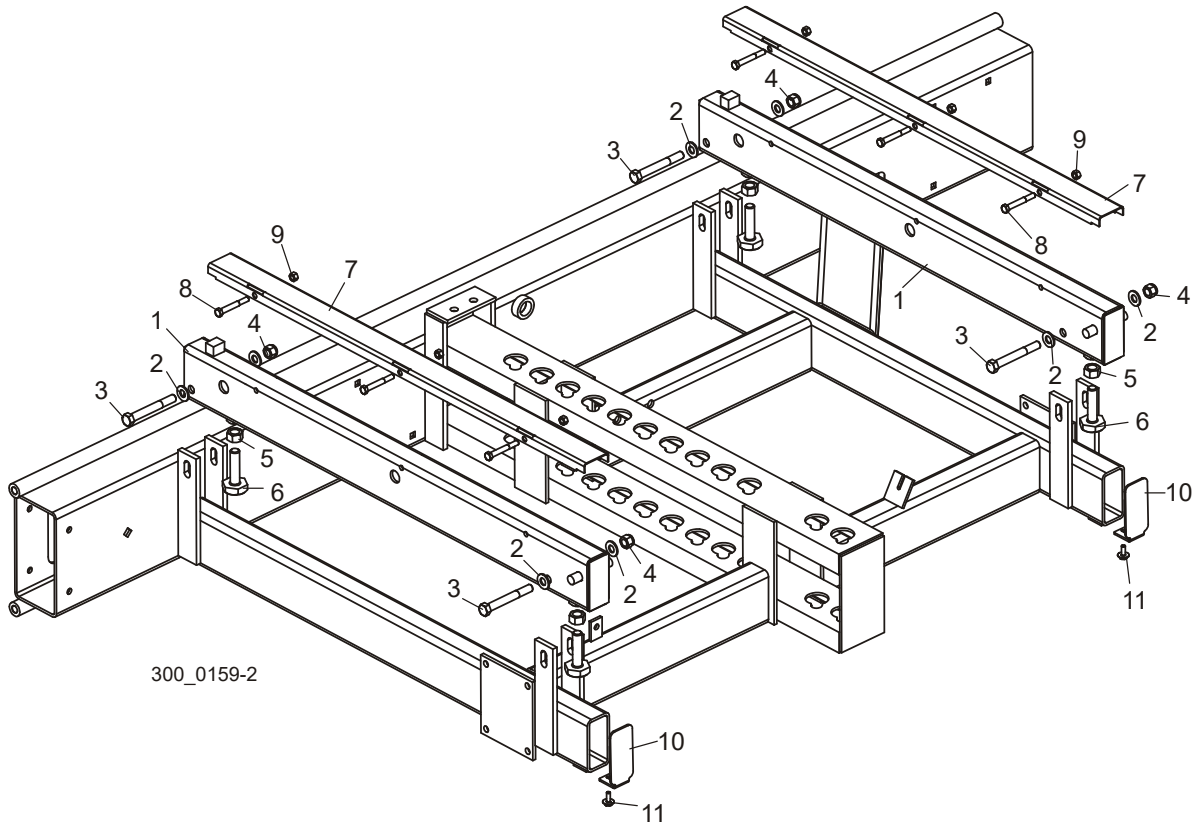

300_0159-2

REF	DESCRIPTION (◆ Indicates Parts Available In Assemblies Only)	PART #	QTY.
	RAIL ASSEMBLY, EXTENSION BED	017760	2
1	Tube Weldment, Bed Rail	017759	1
2	Washer, 1/2" SAE Flat	F05011-2	4
3	Bolt, 1/2-13 x 4" Hex Head Grade 5	F05008-78	2
4	Nut, 1/2-13 Hex Nylon Lock	F05010-8	2
5	Nut, 5/8-11 Hex	F05010-5	2
6	Bolt, Bed Rail Adjustment	S13006	2
7	Cover, 36 1/4" Stainless Bed Rail	016898	1
8	Bolt, 5/16-18 x 2 1/2" Hex Head	F05006-10	3
9	Nut, 5/16-18 Hex Lock	F05010-6	3
10	PLATE, 2X4 BED RAIL CAP	038843	2
11	BOLT, 1/4-20 X 3/4" W/CONICAL WASHER HEAD	F05005-134	2

13 Bed Extension

Manual Clamp (BX6)

13.3 Manual Clamp (BX6)

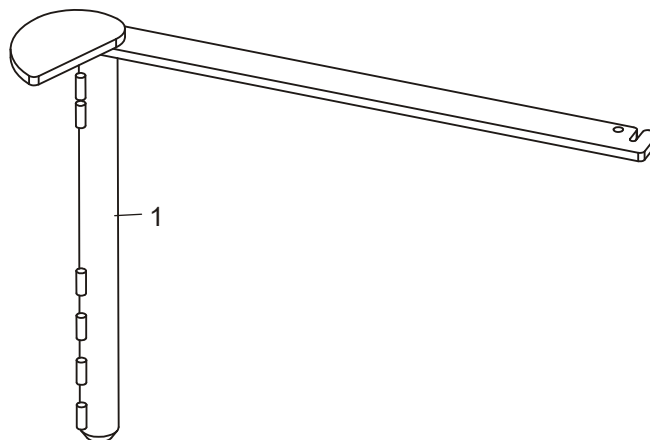
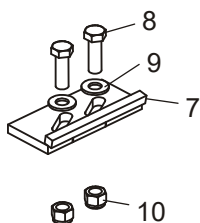

300_0159-4

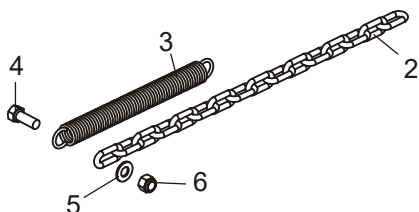

REF	DESCRIPTION (◆ Indicates Parts Available In Assemblies Only)	PART #	QTY.
1	CLAMP WELDMENT, MANUAL LOG	W09412	1
2	CHAIN, 3/16" X 67" ZINC PLATED	M04311	1
3	SPRING, 7/8" X 8 1/2" X 1/8" EXTENSION	P09135	1
4	BOLT, 3/8-16 X 1" HEX HEAD	F05007-7	1
5	WASHER, 3/8" SAE FLAT	F05011-3	1
6	NUT, 3/8-16 HEX NYLON LOCK	F05010-10	1
7	STOP WELDMENT, CLAMP	W09404	1
8	BOLT, 1/2-13 X 1 1/2" HEX HEAD GRADE 5	F05008-33	2
9	WASHER, 1/2" SAE FLAT	F05011-2	2
10	NUT, 1/2-13 HEX NYLON LOCK	F05010-8	2

13.4 Connection Hardware (BX6)

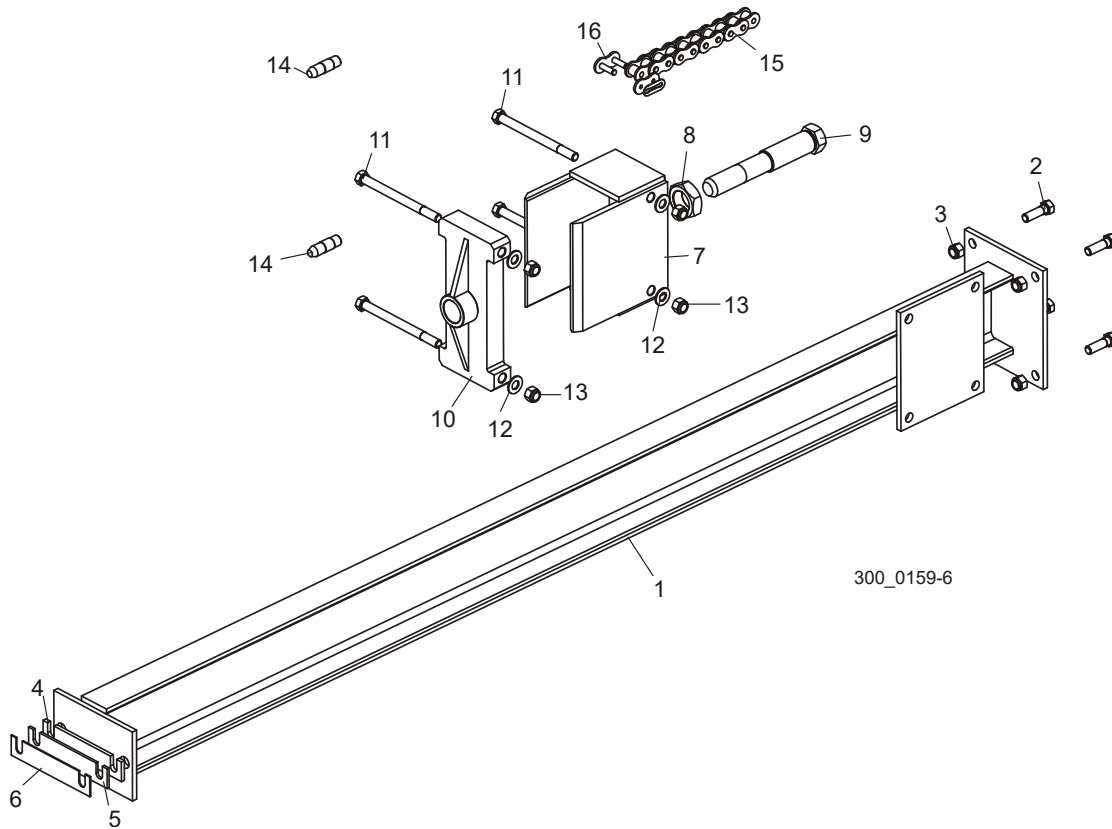

REF	DESCRIPTION (◆ Indicates Parts Available In Assemblies Only)	PART #	QTY.
1	BRACE WELDMENT, BX6	006596	1
2	BOLT, 3/8-16 X 1 1/4" HEX HEAD	F05007-2	4
3	NUT, 3/8-16 HEX NYLON LOCK	F05010-10	4
4	SHIM, 7 GAUGE BEDX	S12025-7	2
5	SHIM, 11 GAUGE BEDX	S12025-11	2
6	SHIM, 16 GAUGE BEDX	S12025-16	2
	BOX ASSEMBLY, BEDX CONNECTION	017700	1
7	Box Weldment, BedX Connection	017695	1
8	Nut, 1-14 Left Hand Hex Jam	F05010-172	1
9	Screw, BedX Connection	017690	1
10	Plate Weldment, BedX Connection	017699	1
11	Bolt, 3/8-16 x 4 3/4" Hex Head Grade 5	F05007-109	4
12	Washer, 3/8" SAE Flat	F05011-13	4
13	Nut, 3/8-16 Hex Nylon Lock	F05010-10	4
14	PIN, BEDX CONNECTING	017689	2
15	CHAIN, #60 X 70 1/2"	017840	1
16	LINK, #60 MASTER	042398	1

13 Bed Extension

Hydraulic Flow Control Valve (BX10)

13.5 Hydraulic Flow Control Valve (BX10)

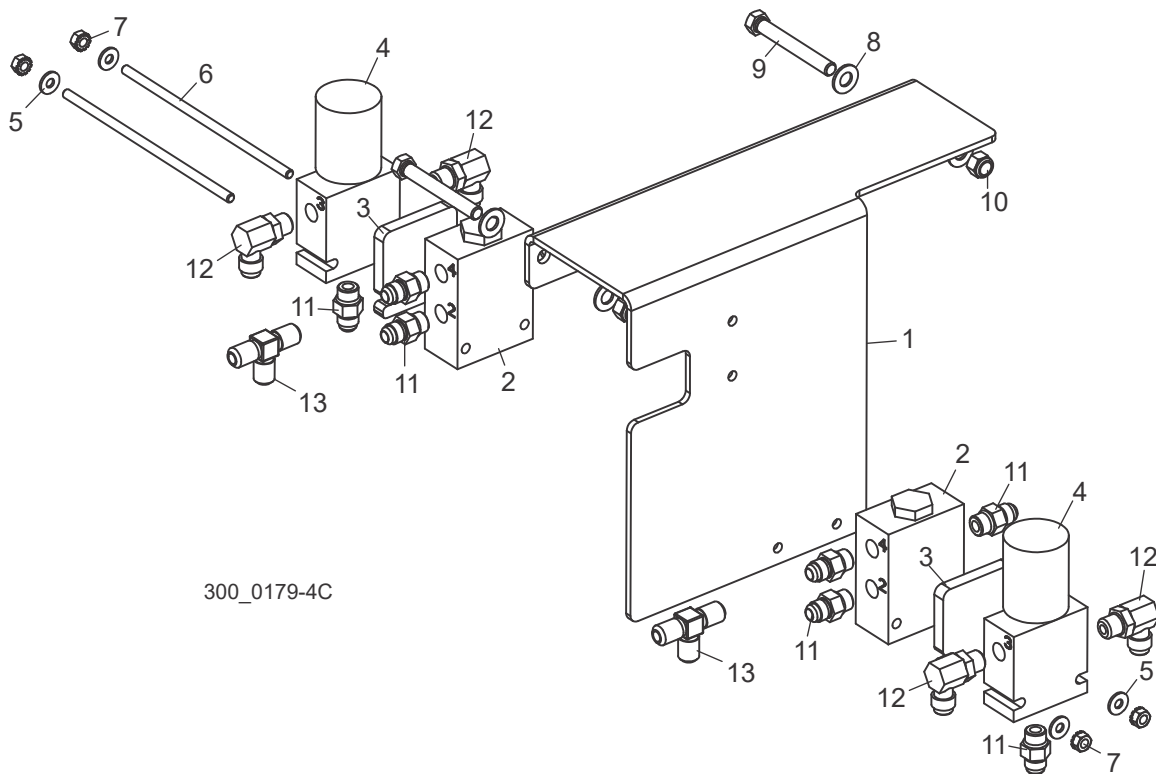

REF	DESCRIPTION (◆ Indicates Parts Available In Assemblies Only)	PART #	QTY.
	VALVE ASSEMBLY, HYDRAULIC BX10 FLOW CONTROL	007501	1
1	Plate, Flow Divider Valve Mount	007272	1
2	Valve, Hydraulic Flow Divider	007588	2
3	Plate, Flow Divider Valve Spacer	007271	2
4	Valve, 24VDC Hydraulic Flow Diverter	007589	2
5	Washer, 1/4" SAE Flat	F05011-11	4
6	Screw, 1/4-20 x 6 1/2" Socket Head	008950	2
7	Nut, 1/4-20 Hex Nylon Lock	F05010-9	4
8	Washer, 3/8" SAE Flat	F05011-3	4
9	Bolt, 3/8-16 x 3" Hex Head Full Thread	F05007-1	2
10	Nut, 3/8-16 Hex Nylon Lock	F05010-10	2
11	Fitting, 3/8" O-Ring x 3/8" JIC	014687	8
12	Fitting, #6 SAE x 3/8" JIC Elbow	P12704	4
13	Fitting, 3/8" JIC Tee	015487	2

INDEX

B

bed extension
 bed rails (BX6) 13-2
 complete BX6 13-1
 connection hardware (BX6) 13-4
 hydraulic flow control (BX10) 13-5
 manual clamp (BX6) 13-3

bed frame
 bed rail (middle) 7-3
 bed rail #1 7-1
 bed rail #2 7-2
 bed rail #4 7-4
 bed rail #5 7-5
 cable carrier 7-13
 leg (#2 & #5) 7-8, 7-9
 leg (#3 & #4) 7-10, 7-11
 leg (front & rear) 7-6, 7-7
 wireway 7-12

blade guide arm 2-11

blade guides
 block kit 2-2
 drive side assembly 2-7, 2-9
 idle side assembly 2-3, 2-5
 idle side roller 2-1, 2-2
 roller/block kit 2-1

blade wheels
 brake actuator & strap 3-7
 drive side 3-3, 3-5
 idle side w/brake 3-2

C

cab option 12-1
 front panel 12-6
 left panel 12-7
 rear panel 12-2
 right panel 12-4
 roof 12-8

D

drive assembly
 blade motor 4-12

drive shaft 3-1

E

electrical harnesses & cables 9-5

H

hydraulics
 hoses 8-22
 log clamp 8-9
 log loader 8-1
 log turner 8-7
 pump & tank 8-13
 side support (middle) 8-5
 side supports 8-3
 taper set roller 8-19
 taper set roller valve 8-21
 toe board (front) 8-11
 toe board (rear w/ramp) 8-15
 toe board (rear) 8-12
 turner sequence valve 8-18
 valve 8-16

L

lube system 9-1

lube system (optional pressure) 11-1

M

manuals 9-4

O

operator station
 air supply 10-7
 frame/rails/ladder 10-1
 seat/joystick controls 10-3, 10-5

P

pantograph 9-7

parts list
 how to use 1-1

power feed
 drive 6-5
 feed chain/stops 6-7
 lower track rollers 6-3
 lower wireway 6-8
 upper track rollers 6-1

S

saw head
 blow-off assembly 4-5
 board return 4-1
 board return guide 4-2
 covers 4-3
 decals 4-8
 head/air box 4-9
 laser assembly 4-6

T

tools 9-3

U

up/down
 ballscrew mount (middle) 5-6
 ballscrew mount (top) 5-8
 bearing rails 5-3, 5-11
 drive 5-4
 head stop 5-9
 mast pads/rollers 5-1
 transducer 5-9