



## **Safety, Setup & Operation Manual**

---

**LT300, LT300-BX6 &  
LT300-BX10            rev. A1.00 - B4.01**

---



**Safety is our #1 concern!** Read and understand all safety information and instructions before operating, setting up or maintaining this machine.

*April 2005*

*Form #989*

# Table of Contents

# Section-Page

<b>ABOUT THIS MANUAL</b>		<b>VI</b>
<b>SECTION 1</b>	<b>SAFETY</b>	<b>1-1</b>
1.1	Safety Symbols.....	1-1
1.2	Safety Instructions.....	1-2
<b>SECTION 2</b>	<b>SERVICING THE SAWMILL</b>	<b>2-1</b>
2.1	If You Need To Order Parts .....	2-1
2.2	If You Need Service .....	2-1
2.3	Customer and Sawmill Identification.....	2-2
<b>SECTION 3</b>	<b>SETUP</b>	<b>3-1</b>
3.1	Site Preparation .....	3-1
3.2	Operator Station Installation.....	3-3
3.3	Sawmill Installation.....	3-5
3.4	Bed Extension Installation (Optional).....	3-6
	3.4.1 Leg Installation (BX6) .....	3-6
	3.4.2 Leg Installation (BX10) .....	3-7
	3.4.3 Extension Frame Installation (BX6/BX10).....	3-8
3.5	Pantograph Cable Boom.....	3-13
3.6	Lube Installation.....	3-21
	3.6.1 Standard Lube System (Rev. A9.05+).....	3-21
	3.6.2 Standard Lube System (Rev. A1.00 - A9.04).....	3-24
	3.6.3 Optional Pressure Lube System.....	3-25
3.7	Electrical Installation.....	3-27
	3.7.1 LT300 Rev. B3.00+.....	3-27
	Electrical Requirements .....	3-27
	Installation.....	3-28
	3.7.1 Power Feed & Up/Down Cables .....	3-33
	3.7.2 Up/Down Brake Cable.....	3-34
	3.7.3 Blade Motor Cable .....	3-35
	3.7.4 Head Box Cable.....	3-36
	3.7.5 Transducer Cable .....	3-38
	3.7.6 Lube System Cable.....	3-39
	3.7.7 Debarker Option Foot Switch.....	3-40
	3.7.8 Debarker Option Motor.....	3-41

## Table of Contents

## Section-Page

3.8	Electrical Installation.....	3-42
	3.8.1 <i>LT300 Rev. A9.00 - B2.02.....</i>	3-42
	3.8.2 <i>Power Feed &amp; Up/Down Cables.....</i>	3-47
	3.8.3 <i>Up/Down Brake Cable.....</i>	3-48
	3.8.4 <i>Blade Motor Cable.....</i>	3-49
	3.8.5 <i>Head Box Cable.....</i>	3-50
	3.8.6 <i>Transducer Cable.....</i>	3-52
	3.8.7 <i>Lube System Cable.....</i>	3-53
	3.8.8 <i>Debarker Option Foot Switch.....</i>	3-54
	3.8.9 <i>Debarker Option Motor.....</i>	3-55
3.9	Electrical Installation.....	3-56
	3.9.1 <i>LT300 Rev. A1.00 - A8.00.....</i>	3-56
	3.9.2 <i>Power Feed &amp; Up/Down Cables.....</i>	3-61
	3.9.3 <i>Up/Down Brake Cable.....</i>	3-62
	3.9.4 <i>Blade Motor Cable.....</i>	3-63
	3.9.5 <i>Head Box Cable.....</i>	3-64
	3.9.6 <i>Transducer Cable.....</i>	3-66
	3.9.7 <i>Lube System Cable.....</i>	3-67
	3.9.8 <i>Bed Sensor Cable (Rev. A1.00 - A5.01 Only).....</i>	3-68
3.10	Hydraulic Installation.....	3-69
3.11	Air Installation.....	3-75
3.12	Sawmill Installation Setup.....	3-77
	3.12.1 <i>Level Sub-Frame.....</i>	3-77
	3.12.2 <i>Level Saw Head.....</i>	3-80
	3.12.3 <i>Level Bed Rails.....</i>	3-84
	3.12.4 <i>Level Blade Guide Arm.....</i>	3-85
	3.12.5 <i>Side Support Setup.....</i>	3-88
3.13	Initial Control Programming.....	3-89
	3.13.1 <i>Blade Height Calibration.....</i>	3-89
	3.13.2 <i>Upper Saw Head Travel Limit.....</i>	3-91
	3.13.3 <i>Power Feed Calibration.....</i>	3-91
	3.13.4 <i>Kerf.....</i>	3-91

# Table of Contents

# Section-Page

<b>SECTION 4</b>	<b>OPERATION</b>	<b>4-1</b>
4.1	Control Overview .....	4-1
4.2	Distribution Box Overview .....	4-5
4.3	Joystick Control Overview .....	4-7
4.4	Cruise Control .....	4-12
4.5	Programming The Control.....	4-13
	4.5.1 Board Thickness .....	4-13
	4.5.2 Cant Size .....	4-14
	4.5.3 Max HP, Max PF & Lube.....	4-15
	4.5.4 Calibration.....	4-16
	4.5.5 Upper Saw Head Travel Limit.....	4-16
	4.5.6 Other Settings (Software Versions 4.5+ Only).....	4-17
4.6	Starting The Machine .....	4-18
4.7	Installing A Blade.....	4-19
4.8	Loading, Turning And Clamping Logs .....	4-22
4.9	Setworks Overview .....	4-28
	4.9.1 Temporary Reference Mode .....	4-29
	4.9.2 Pattern Mode .....	4-35
4.10	Sawing Logs .....	4-38
	4.10.1 Prepare the sawmill for loading a log.....	4-38
	4.10.2 Load the log.....	4-38
	4.10.3 Turn the log .....	4-39
	4.10.4 Clamp the log.....	4-39
	4.10.5 Level the log.....	4-39
	4.10.6 Saw the log.....	4-39
<b>SECTION 5</b>	<b>MAINTENANCE</b>	<b>5-1</b>
5.1	Blade Guides (Standard Block/Roller Guides).....	5-1
5.2	Sawdust Removal .....	5-5
5.3	Track Rails & Scrapers.....	5-6
5.4	Miscellaneous .....	5-9
5.5	Proximity Sensors.....	5-10
	5.5.2 Toe Board Sensors (Rev. A1.00 - A5.01 Only) .....	5-10
	5.5.3 Broken Blade Sensor .....	5-11
	5.5.4 Up/Down Ball Screw Sensor (Rev. A3.00+).....	5-12
5.6	Hydraulic System Maintenance.....	5-13
5.7	Blade Wheel Bearings & Scrapers .....	5-14
5.8	Up/Down System.....	5-15
5.9	Power Feed .....	5-17
5.10	Drive Belt Tension & Alignment .....	5-20
5.11	Turner Chain Tension.....	5-24
<b>SECTION 6</b>	<b>TROUBLESHOOTING</b>	<b>6-1</b>
6.1	Error Codes.....	6-1



# Table of Contents

# Section-Page

6.2	Blade Guides .....	6-5	
<b>SECTION 7</b>	<b>ALIGNMENT</b>		<b>7-1</b>
7.1	Bed Frame .....	7-1	
	7.1.1 Level Bed Frame In Length Direction .....	7-1	
	7.1.2 Level Bed Frame In Width Direction .....	7-2	
	7.1.3 Level Saw Head .....	7-3	
	7.1.4 Level Bed Rails .....	7-5	
	7.1.5 Align Side Supports .....	7-6	
7.2	Blade Guides (Standard Block/Roller Guides).....	7-7	
	7.2.1 Blade Guide Adjustment Overview.....	7-7	
	7.2.2 Preparing For Blade Guide Alignment .....	7-17	
	7.2.3 Blade Wheel Vertical Alignment.....	7-18	
	7.2.4 Blade Guide Arm Alignment.....	7-20	
	7.2.5 Blade Guide Alignment.....	7-22	
<b>SECTION 8</b>	<b>HYDRAULIC INFORMATION</b>		<b>8-1</b>
8.1	Hydraulic Schematics.....	8-1	
	LT300 Rev. A9.00+ .....		
	LT300-BX6 Rev. B3.02+.....	8-1	
8.2	Hydraulic Schematic .....	8-2	
	LT300 Rev. A7.00 - A8.00.....	8-2	
8.3	Hydraulic Schematic .....	8-3	
	LT300 Rev. A1.00 - A6.01.....	8-3	
8.4	Hydraulic Schematic .....	8-4	
	LT300-BX10 .....	8-4	
8.5	Hydraulic Hoses .....	8-5	
	LT300 Rev. A7.00+.....	8-5	
8.6	Hydraulic Hoses .....	8-7	
	LT300 Rev. A5.00 - A6.01.....	8-7	
8.7	Hydraulic Hoses .....	8-8	
	LT300 Rev. A1.00 - A4.00.....	8-8	
8.8	Hydraulic Components.....	8-9	

## INDEX

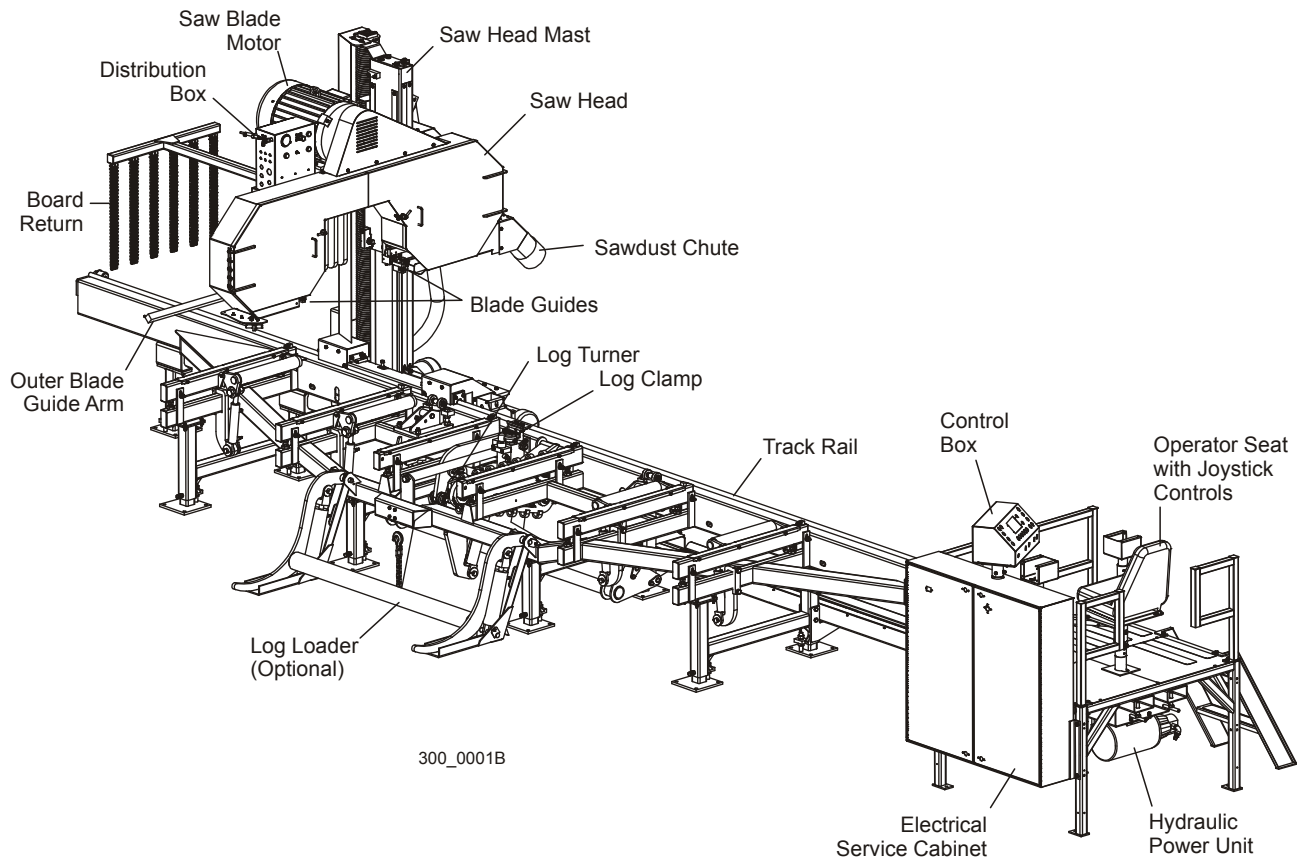
I

# ABOUT THIS MANUAL

This manual is to replace or to be used with all previous information received on the Wood-Mizer sawmill. All future mailings will be an addition to or a revision of individual sections of this manual as we obtain new information.

The information and instructions given in this manual do not amend or extend the limited warranties for the equipment given at the time of purchase.

For general information regarding Wood-Mizer and our “Forest to Final Form” products, please refer to the All Products Catalog in your support package.



**MILL COMPONENTS**

## SECTION 1 SAFETY

### 1.1 Safety Symbols

The following symbols and signal words call your attention to instructions concerning your personal safety. Be sure to observe and follow these instructions.



**DANGER!** indicates an imminently hazardous situation which, if not avoided, will result in death or serious injury.



**WARNING!** suggests a potentially hazardous situation which, if not avoided, could result in death or serious injury.



**CAUTION!** refers to potentially hazardous situations which, if not avoided, may result in minor or moderate injury or damage to equipment.



**IMPORTANT!** indicates vital information.

**NOTE:** gives helpful information.



Warning stripes are placed on areas where a single decal would be insufficient. To avoid serious injury, keep out of the path of any equipment marked with warning stripes.

### 1.2 Safety Instructions

**NOTE:** ONLY safety instructions regarding personal injury are listed in this section. Caution statements regarding only equipment damage appear where applicable throughout the manual.

#### OBSERVE SAFETY INSTRUCTIONS



**IMPORTANT!** Read the entire Operator's Manual before operating the sawmill. Take notice of all safety warnings throughout this manual and those posted on the machine. Keep this manual with this machine at all times, regardless of ownership.

Also read any additional manufacturer's manuals and observe any applicable safety instructions including dangers, warnings, and cautions.

Only persons who have read and understood the entire operator's manual should operate the sawmill. The sawmill is not intended for use by or around children.

**IMPORTANT!** It is always the owner's responsibility to comply with all applicable federal, state and local laws, rules and regulations regarding the ownership and operation of your Wood-Mizer sawmill. All Wood-Mizer mill owners are encouraged to become thoroughly familiar with these applicable laws and comply with them fully while using the mill.

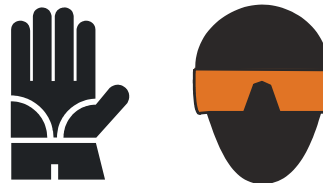


#### WEAR SAFETY CLOTHING



**WARNING!** Secure all loose clothing and jewelry before operating the sawmill. Failure to do so may result in serious injury or death.

**WARNING!** Always wear gloves and eye protection when handling band-saw blades. Changing blades is safest when done by one person! Keep all other persons away from area when coiling, carrying or changing a blade. Failure to do so may result in serious injury.



**WARNING!** Always wear eye, ear, respiration, and foot protection when operating or servicing the sawmill.



### KEEP SAWMILL AND AREA AROUND SAWMILL CLEAN



**DANGER!** Maintain a clean and clear path for all necessary movement around the mill and lumber stacking areas. Failure to do so will result in serious injury.

### HANDLE FUEL/LUBRICANTS SAFELY



**WARNING!** Use ONLY water or approved additives with the lube system. Never use flammable fuels or liquids. If these types of liquids are necessary to clean the blade, remove it and clean with a rag. Failure to do so may result in serious injury or death.



### DISPOSE OF SAWING BY-PRODUCTS PROPERLY



**IMPORTANT!** Always properly dispose of all sawing by-products, including sawdust and other debris.

### CAUTIONS FOR SAWMILL SETUP



**WARNING!** Securely fasten the feet of the sawmill to the floor before operating the sawmill. Failure to do so may result in serious injury or death.

### CHECK SAWMILL/BLADES BEFORE OPERATION



**DANGER!** Make sure all guards and covers are in place and secured before operating the sawmill. Failure to do so may result in serious injury.



**WARNING!** Blade guide alignment is essential for optimal cutting performance, blade life and safety. Failure to check and maintain proper blade guide alignment will result in stress cracks forming in the blade. These cracks will lead to premature blade breakage. If the blade breaks during operation and the blade has multiple stress cracks, the blade could shatter into several pieces and escape from the protective guards of the



# 1 Safety

## Safety Instructions

---

sawmill. Small blade pieces projected into the area around the sawmill creates a safety hazard for the operator and any bystanders surrounding the mill.

**WARNING!** DO NOT use blades with stress cracks. Blades with stress cracks can shatter causing bodily injury and/or machine damage.

### KEEP PERSONS AWAY



**DANGER!** Keep all persons out of the path of moving equipment and logs when operating sawmill or loading and turning logs. Failure to do so will result in serious injury.

**DANGER!** Always be sure all persons are out of the path of the blade before starting the motor. Failure to do so will result in serious injury.

### KEEP HANDS AWAY



**DANGER!** Always shut off the sawmill and wait until the blade wheels have come to a complete stop before changing the blade. Failure to do so will result in serious injury.

**DANGER!** Always keep hands away from moving bandsaw blade. Failure to do so will result in serious injury.

**DANGER!** Always be aware of and take proper protective measures against rotating shafts, pulleys, fans, etc. Always stay a safe distance from rotating members and make sure that loose clothing or long hair does not engage rotating members resulting in possible injury.



**WARNING!** Do not spin the blade wheels by hand. Spinning the blade wheels by hand may result in serious injury.

**WARNING!** Always stop the blades when the sawmill is not cutting. Failure to do so may result in serious injury.

**WARNING!** Do not for any reason adjust the drive belts with the motor running. Doing so may result in serious injury.

**WARNING!** Always keep clear of exiting sawdust. Keep hands,

feet and any other objects away from the sawdust chute when operating sawmill. Failure to do so may result in serious injury.

## USE PROPER PROCEDURE WHEN CONDUCTING ELECTRICAL SAFETY CHECKS AND MAINTENANCE



**DANGER!** Make sure all electrical installation, service and/or maintenance work is performed by a qualified electrician and is in accordance with applicable electrical codes.

**DANGER!** HARC FLASH AND SHOCK HAZARD! Hazardous voltage inside the electric sawmill disconnect box, starter box, and at the motor can cause shock, burns, or death. Disconnect and lock out power supply before servicing! Keep all electrical component covers closed and securely fastened during mill operation. Wear appropriate Personal Protection Equipment.

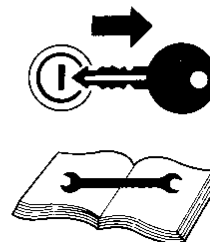


**WARNING!** Consider all electrical circuits energized and dangerous.

**WARNING!** Never assume or take the word of another person that the power is off; check it out and lock it out.

**WARNING!** Do not wear rings, watches, or other jewelry while working around an open electrical circuit.

**WARNING!** Before performing service near moving parts such as blades, pulleys, motors, belts and chains, first turn the key switch to the OFF (#0) position and remove the key. If the key is turned on and moving parts activated, serious injury may result.



**WARNING!** Remove the blade before performing any service to the engine or sawmill. Failure to do so may result in serious injury.

**DANGER!** Lockout procedures must be used during:

- Changing or adjusting blades
- Unjamming operations
- Cleaning
- Mechanical repair
- Electrical maintenance

Retrieval of tools/parts from work area  
Activities where guards or electrical panel guard is open or removed

**Maintenance hazards include:**

Blade contact  
Pinch points  
Kickbacks  
Missiles (thrown blades/wood chips)  
Electrical

Failure to lockout may result in:

Cut  
Crush  
Blindness  
Puncture  
Serious injury and death  
Amputation  
Burn  
Shock  
Electrocution

**To control maintenance dangers:**

Lockout procedures must be followed (see ANSI Standard Z244.1-1982 and OSHA regulation 1910.147).

Never rely on machine stop control for maintenance safety (emergency stops, on/off buttons, interlocks).

Do not reach into moving blades or feed systems. Allow all coasting parts to come to a complete stop.

Electrical power supply and air supply must both be locked out.

Where established lockout procedures cannot be used (electrical troubleshooting or mechanical dynamic troubleshooting), alternative effective protective techniques shall be employed which may require special skills and planning.

Always follow safe operations practices in the workplace.

**LOCKOUT PROCEDURE**

Lockout procedures must be followed (see ANSI Standard Z244.1-1982 and OSHA regulation 1910.147).

**Purpose:**

This procedure establishes the minimum requirements for lockout of energy sources that



could cause injury.

**Responsibility:**

The responsibility for seeing that this procedure is followed is binding upon all workers. All workers shall be instructed in the safety significance of the lockout procedure. It is your responsibility to ensure safe operation of the machine.

**Preparation For Lockout:**

The saw must be locked out both electrically and pneumatically (lockout air valve).

**Sequence of Lockout Procedure:**

1. Notify all persons that a lockout is required and the reason therefore.
2. If the saw is operating, shut it down by the normal stopping procedure.
3. Operate the switch and valve so that the energy sources are disconnected or isolated from the saw. Stored energy such as moving blades, feed system and air pressure shall be dissipated.
4. Lockout the energy isolating devices with assigned individual locks.
5. After ensuring that no persons are exposed and as a check on having disconnected the energy sources, operate the push button or other normal operating controls to make certain the saw will not operate. Caution: Return operating controls to neutral position after the test.
6. The saw is now locked out.

**Restoring Equipment to Service**

1. When the job is complete and the saw is ready for testing or normal service, check the saw area to see that no one is exposed.
2. When the saw is all clear, remove all locks. The energy isolating devices may be operated to restore energy to the saw.

**Procedure Involving More Than One Person**

In the preceding steps, if more than one individual is required to lock out the saw, each shall place his own personal lock on the energy isolating devices.

**Rules for Using Lockout Procedure**

The saw shall be locked out to protect against accidental or inadvertent operation when such operation could cause injury to personnel. Do not attempt to operate any switch or valve bearing a lock.

### Owner's Responsibility

The procedures listed in this manual may not include all ANSI, OSHA, or locally required safety procedures. It is the owner/operator's responsibility and not Wood-Mizer Products to ensure all operators are properly trained and informed of all safety protocols. Owner/Operators are responsible for following all safety procedures when operating and performing maintenance to the saw.

### KEEP SAFETY LABELS IN GOOD CONDITION



**IMPORTANT!** Always be sure that all safety decals are clean and readable. Replace all damaged safety decals to prevent personal injury or damage to the equipment. Contact your local distributor, or call your Customer Service Representative to order more decals.



**IMPORTANT!** If replacing a component which has a safety decal affixed to it, make sure the new component also has the safety decal affixed.

### USE CAUTION WHEN WORKING WITH HEAVY LOGS



**WARNING!** Always make sure log is clamped securely before sawing. Failure to do so may result in serious injury or death.

### AUTOMATIC BOARD RETURN SAFETY



**DANGER!** Keep all persons out of the path of returning boards. Failure to do so will result in serious injury.

### POWER FEED AND UP/DOWN SYSTEM SAFETY



**DANGER!** If leaving the blade engaged for maximum production rates, make sure the off-bearer stays out of the path of the blade. Failure to do so will result in serious injury or death.



**CAUTION!** Be sure the transducer sensor is adjusted properly before raising or lowering the saw head against the upper or lower travel limits. Failure to do so may result in damage to the machine.

## **SECTION 2    SERVICING THE SAWMILL**

Wood-Mizer is committed to providing you with the latest technology, best quality and strongest customer service available on the market today. We continually evaluate our customers' needs to ensure we're meeting current wood-processing demands. Your comments and suggestions are welcome.

### **2.1    If You Need To Order Parts**

From the continental U.S., call our toll-free Parts hotline at **1-800-525-8100**. Please have the vehicle identification number and your customer number ready when you call. Wood-Mizer will accept these methods of payment:

- Visa, Mastercard, or Discover
- COD
- Prepayment
- Net 15 (with approved credit)

Be aware that shipping and handling charges may apply. Handling charges are based on size and quantity of order. In most cases, items will ship on the day they are ordered. Second Day and Next Day shipping are available at additional cost.

If your sawmill was purchased outside of the United States, contact your distributor for replacement parts.

### **2.2    If You Need Service**

From the continental U.S., call us toll-free at **1-800-525-8100**. Ask to speak with a Customer Service Representative. Please have your vehicle identification number and your customer number ready when you call. The Service Representative can help you with questions about alignment of your mill, blade sharpening, or cutting a particular species of wood. He also can schedule you for a service call.

**Office Hours:** All times are Eastern Standard Time.

<b>Monday - Friday</b>	<b>Saturday</b>	<b>Sunday</b>
8 a.m. to 5 p.m.	8 a.m. to 12 p.m.	Closed

If your sawmill was purchased outside the United States, contact the distributor for service.

## 2 Servicing The Sawmill

### Customer and Sawmill Identification

### 2.3 Customer and Sawmill Identification

Each Wood-Mizer sawmill is identified with a serial number, revision, and electrical information (see the figure below).

MFG BY: WOOD-MIZER LLC, 8180 W. 10th St. Indianapolis, IN 46214-2400 317/271-1542 or 800/553-0182						
SERIAL #	LT300 0103002A1.00			FLA OF LARGEST LOAD	39	
FLA	63	IR	2kA	SCCR	VOLTS	460
<i>(Base unit only)</i>						
HZ	60	PH	3	ELECTRICAL DIAGRAM # 1014		
PATENTS				S20038		
300_0003C						

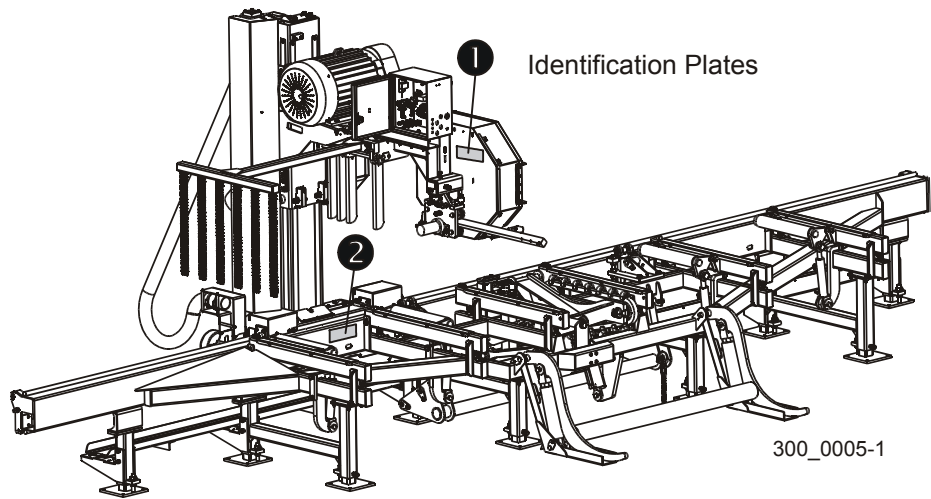
**LT300 IDENTIFICATION PLATE**

The serial number contains the year and month of manufacture and a sequence number. The revision number helps identify the exact design of the equipment. See the table for a description of the serial and revision numbers as shown in the example above.

Model No.	Date Of Manufacture		Machine No.	Revision
	Year	Month		
LT300	01	03	002	A1.00

**SERIAL NUMBER DESCRIPTION**

See the figure below for locations of the identification plates.



**IDENTIFICATION PLATE LOCATIONS**

## SECTION 3 SETUP

### 3.1 Site Preparation



**IMPORTANT!** This information is provided so that you may have your site prepared for installation of your electric sawmill. In order to properly install your sawmill, you need to:

1. **Prepare a firm, level area where the sawmill can be anchored.** There should be enough room around the sawmill for operators, sawdust removal, log loading and board removal. A cement pad with a minimum thickness of 6" and rebar spacing of 24" is recommended. The cement pad should be rated to support 6350 lbs./sq.ft. at each sawmill foot position. 1/2" diameter anchor should be used to secure the equipment to the slab.

The design of your site layout should be determined at the time of purchase. Wood-Mizer can provide detailed plans based on the requirements of your operation and the equipment you plan to install.

The sawmill is designed for indoor operation and should be fully protected from outdoor elements.

2. **Have a qualified electrician install the power supply before receipt of your sawmill.** The power supply must meet the enclosed specifications concerning wire size, fused disconnect, and voltage. The electrical installation must also meet local codes.

**See Table 3-1.** Install a fused disconnect switch within sight of the machine. Typical minimum switch, fuse, and wire sizes are shown. All electrical installation must meet local electrical codes. Fuses are sized for short-circuit protection only. The motor is configured with internal thermostats for overload protection. If an overload condition does occur, the thermostats shut the motor down and the motor cannot be restarted until it cools to a safe operating temperature.

3-Phase Volts	Fuse Disconnect	Time Delay Fuse	Suggested Wire Size
460 VAC	100 Amps	70 Amps	4AWG up to 50'

**TABLE 3-1**

3. **Have a qualified electrician present when the sawmill is to be installed.** All relevant motor specifications and wiring information is provided. When scheduling an electrician for the day of installation, please confirm that they have enough of the proper size cable (wiring), as shown above. Many electricians may not stock this cable, which could seriously delay installation and training.

**See Table 3-2.** This table lists the 30 horsepower motor specifications for your reference.

<b>30hp Electric Motor Specifications</b>	
<b>Horsepower</b>	30
<b>RPM</b>	1765
<b>Volts</b>	460
<b>Amps</b>	39
<b>SF</b>	125
<b>SF Amps</b>	49
<b>NOM EFF</b>	92.4
<b>Frame</b>	286T
<b>Design</b>	B & C
<b>AMB</b>	40° C
<b>INS</b>	F
<b>PH</b>	3
<b>ENCL</b>	TEFC
<b>Code</b>	G
<b>Duty</b>	Continuous

**TABLE 3-2**

### 3.2 Operator Station Installation

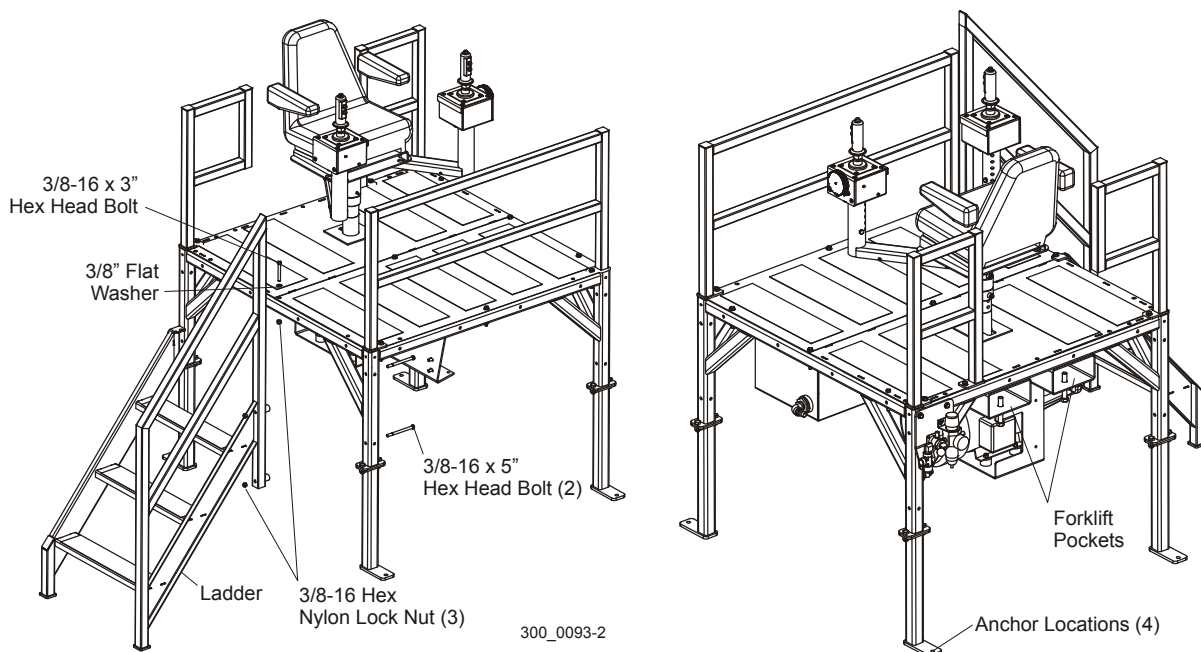
The operator station is equipped with forklift pockets. Use a forklift rated for at least 8,000 lbs. Insert the forks into the pockets and secure with the pocket bolts.

Place the operator station in position. Anchoring the operator station is optional. If the operator station is to be anchored, it is recommended it be anchored after placement of the sawmill. This will allow for repositioning of the operator station relative to the sawmill for your desired operator position. Use 1/2" anchor bolts and nuts at each of the four foot locations to anchor the operator station to the floor if desired.

**Rev. A7.00+:** Install the ladder to the station deck using the provided 3/8-16 x 3" hex head bolt, flat washer, two 3/8-16 x 5" hex head bolts and nylon lock nuts.

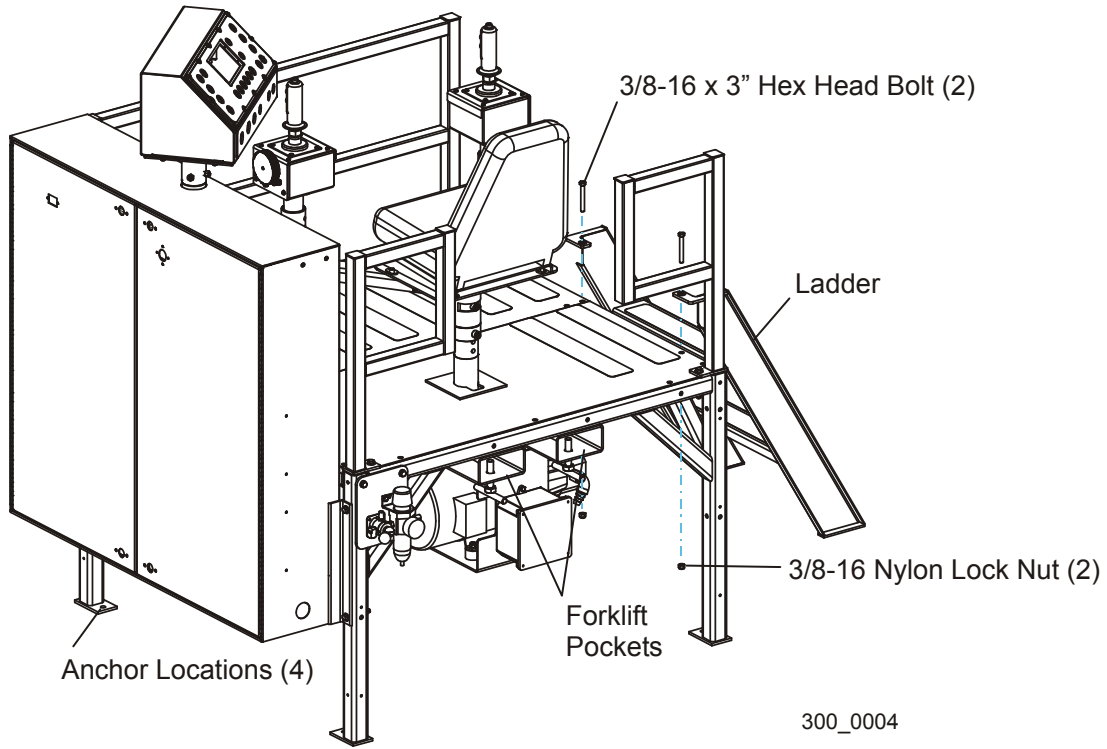
**Rev. A1.00 - A6.01:** Install the ladder to the station deck using the provided 3/8-16 x 3" hex head bolts and nylon lock nuts.

See Figure 3-1.



**FIG. 3-1 REV. A7.00+**





**FIG. 3-1 REV. A1.00 - A6.01**

### 3.3 Sawmill Installation

Position the sawmill approximately 10" from the operator station (if sawmill is equipped with a bed extension option, place the sawmill 6'-10" (BX6) or 10'-10" (BX10) from the operator station). Position the sawmill horizontally so the outside of the main frame tube is aligned with the inside of the operator station leg. Check the position of the operator station in relation to the sawmill. Sit in the operator seat and check the view of the log clamp and side supports. The operator station may be moved in the horizontal direction slightly to obtain the desired view of the sawmill.

After the sawmill is positioned, make sure the horizontal locking bolt and top adjustment nut on each leg is loose. Anchor the sawmill to the floor with 1/2" anchor bolts and nuts. At some foot locations, you may not be able to drill all four anchor bolt holes. Use at least two holes at each foot location.

Remove the saw head rest assembly located under the outer side of the saw head and the saw head rest block located under the inner side of the saw head.

See Figure 3-2.

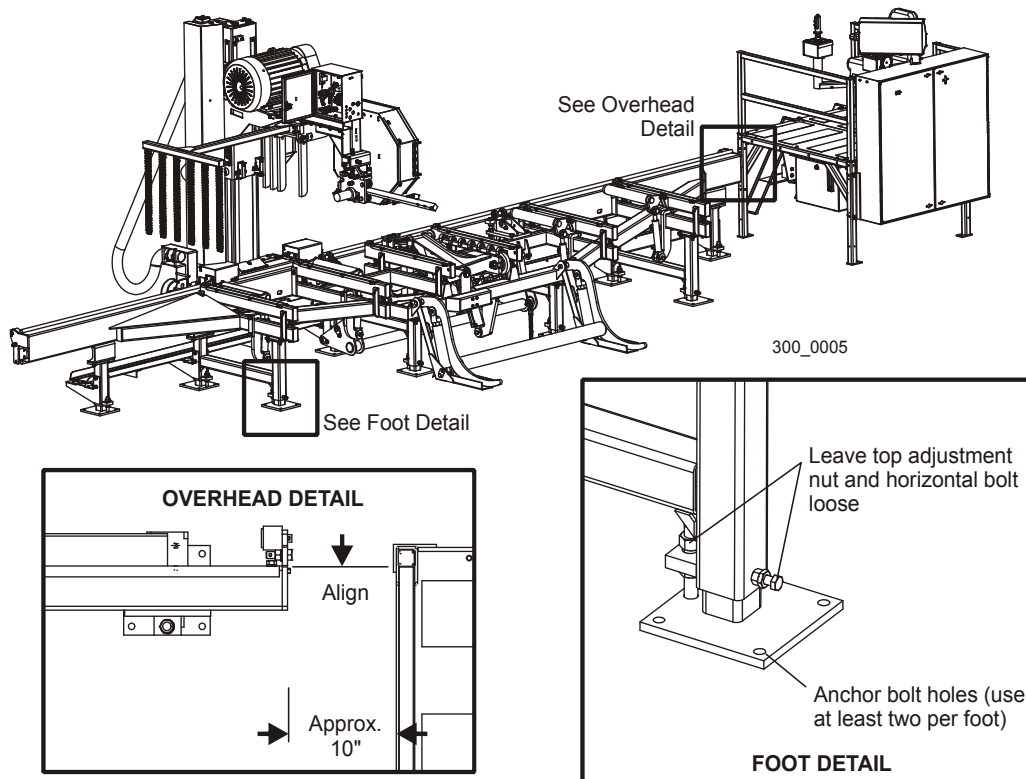


FIG. 3-2

## 3.4 Bed Extension Installation (Optional)

### 3.4.1 Leg Installation (BX6)

See Figure 3-3.

1. Use eight 3/8-16 x 5" carriage head bolts, flat washers and nylon lock nuts to secure the double leg mount to the extension frame. Insert the bolts from the outside of the frame tube and attach the washers and nuts on the leg side of the tube.

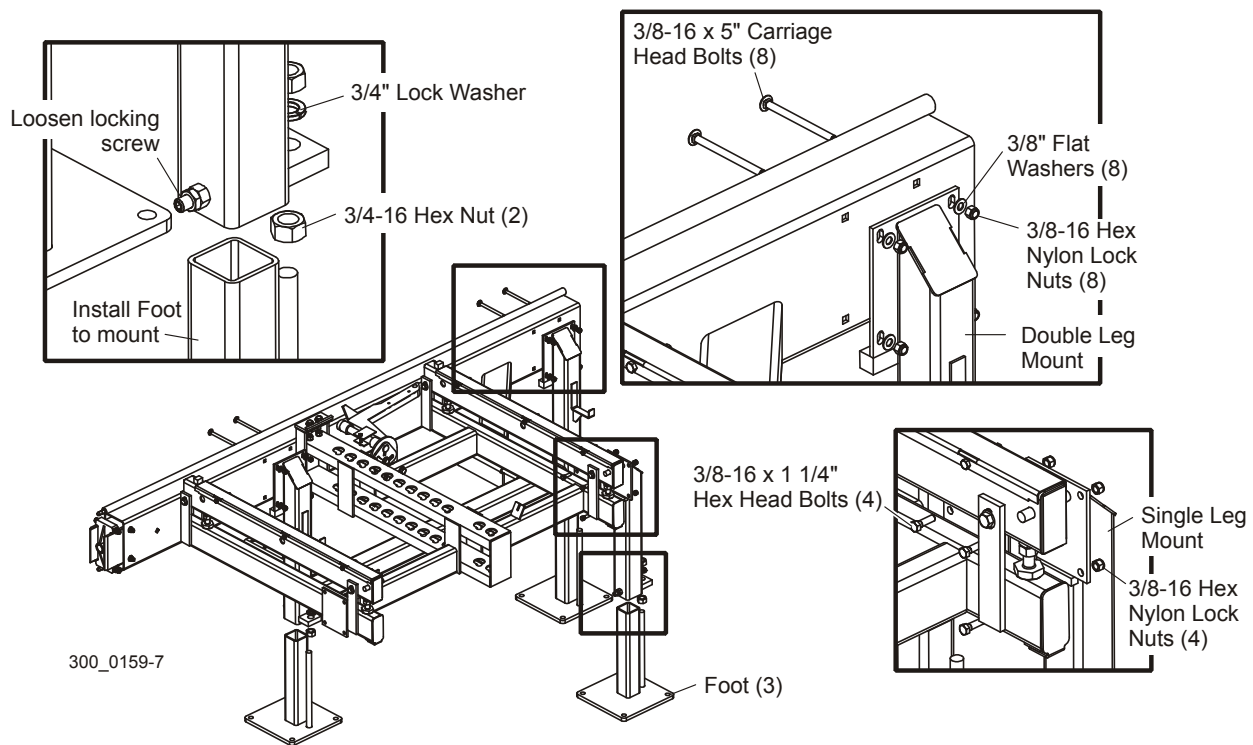


FIG. 3-3

2. Install the single leg mount to the pad located behind the rear extension bed rail using four 3/8-16 x 1 1/4" hex head bolts and lock nuts.
3. Install a 3/4-16 hex nut to the threaded rod on each foot. Install a foot to each mount location. Loosen the locking screw and slide the foot tube up into the mount tube. Install a 3/4" lock washer and second hex nut to the threaded rod on the foot.

# 3 Setup

## Leg Installation (BX10)

### 3.4.2 Leg Installation (BX10)

See Figure 3-4.

1. Use two 1/2-13 x 1 3/4" and four 3/8-16 x 1 1/4" hex head bolts and nylon lock nuts to secure the double leg mounts to the extension frame. Insert the bolts from the top side of the frame tube mount plates and attach the nuts on the bottom side of the leg mount plates.

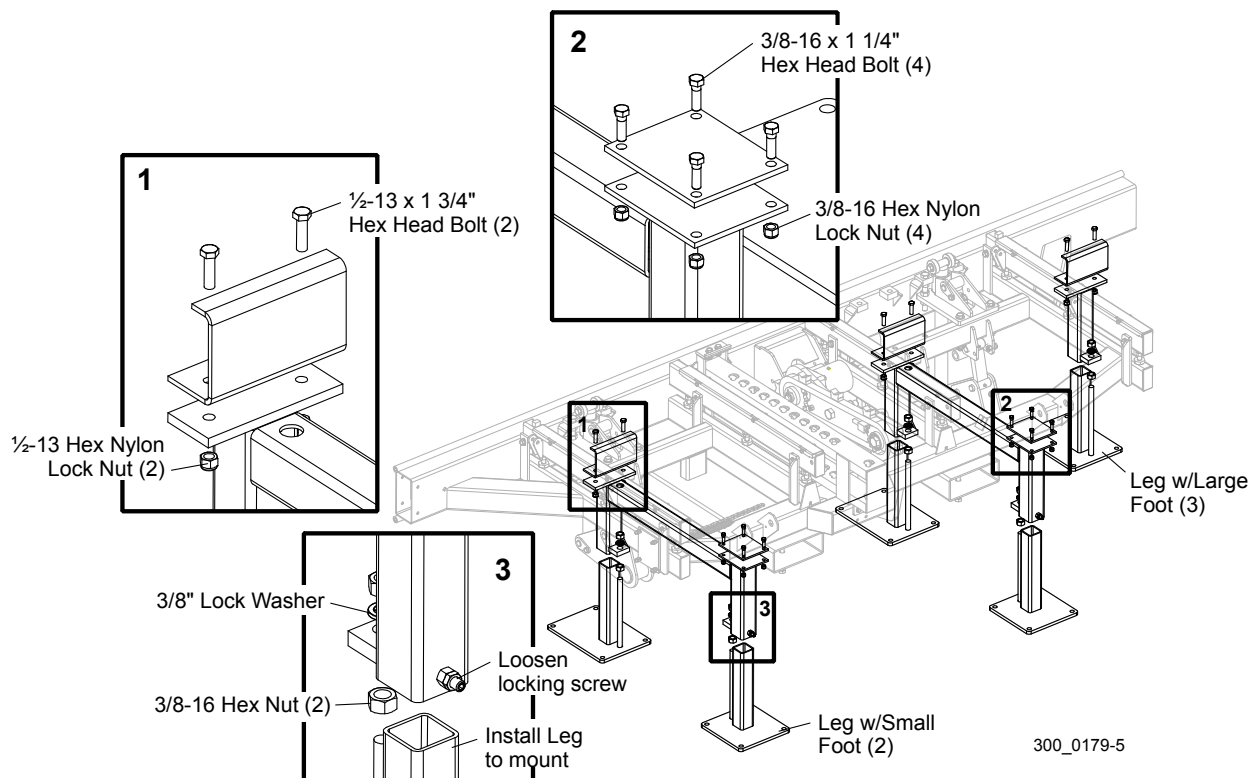


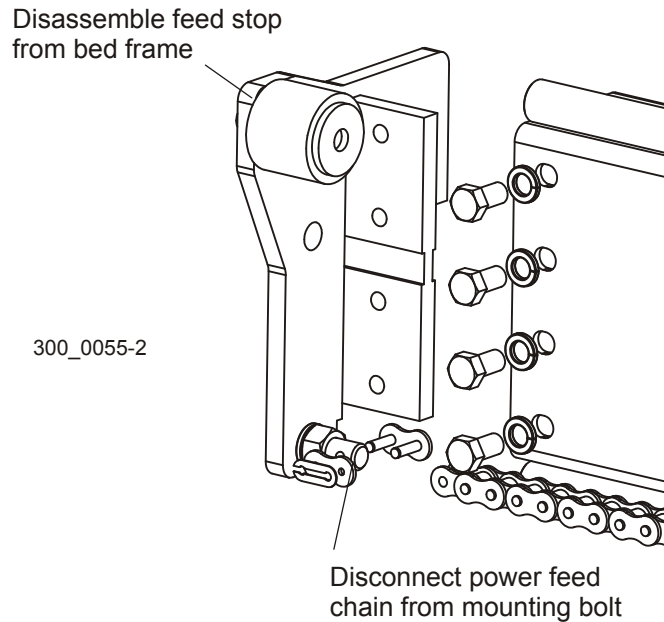
FIG. 3-4

2. Install the single leg mount to the pad located behind the rear extension bed rail using two 1/2-13 x 1 3/4" hex head bolts and lock nuts.
3. Install a 3/4-16 hex nut to the threaded rod on each foot. Install a leg with small foot pad to two front mount locations. Install a leg with large foot pad to three rear mount locations. Loosen the locking screw and slide the foot tube up into the mount tube. Install a 3/4" lock washer and second hex nut to the threaded rod on the foot.

**3.4.3 Extension Frame Installation (BX6/BX10)**

1. Disconnect the feed chain from the feed stop bracket at the front end of the sawmill frame. Break apart the master link to disconnect the chain from the bolt.

See Figure 3-5.



**FIG. 3-5**

2. Remove the bolts and hardware holding the feed stop bracket to the sawmill frame. Remove the entire assembly from the sawmill frame. Use the same bolts and hardware to remount the feed stop bracket assembly to the end of the extension frame.

# 3

## Setup

### Extension Frame Installation (BX6/BX10)

See Figure 3-6.

3. Remove the four mounting bolts from the connecting assembly. Install the adjustment bolt and jam nut to the connecting assembly and into the connection plate. Turn the adjusting bolt counterclockwise until it bottoms against the jam nut to extend the assembly as far as possible. Install the assembly to the bed extension frame tube and secure with two of the mounting bolts, flat washers and nylon lock nuts. Insert a connecting pin into the top and bottom rails of the extension.

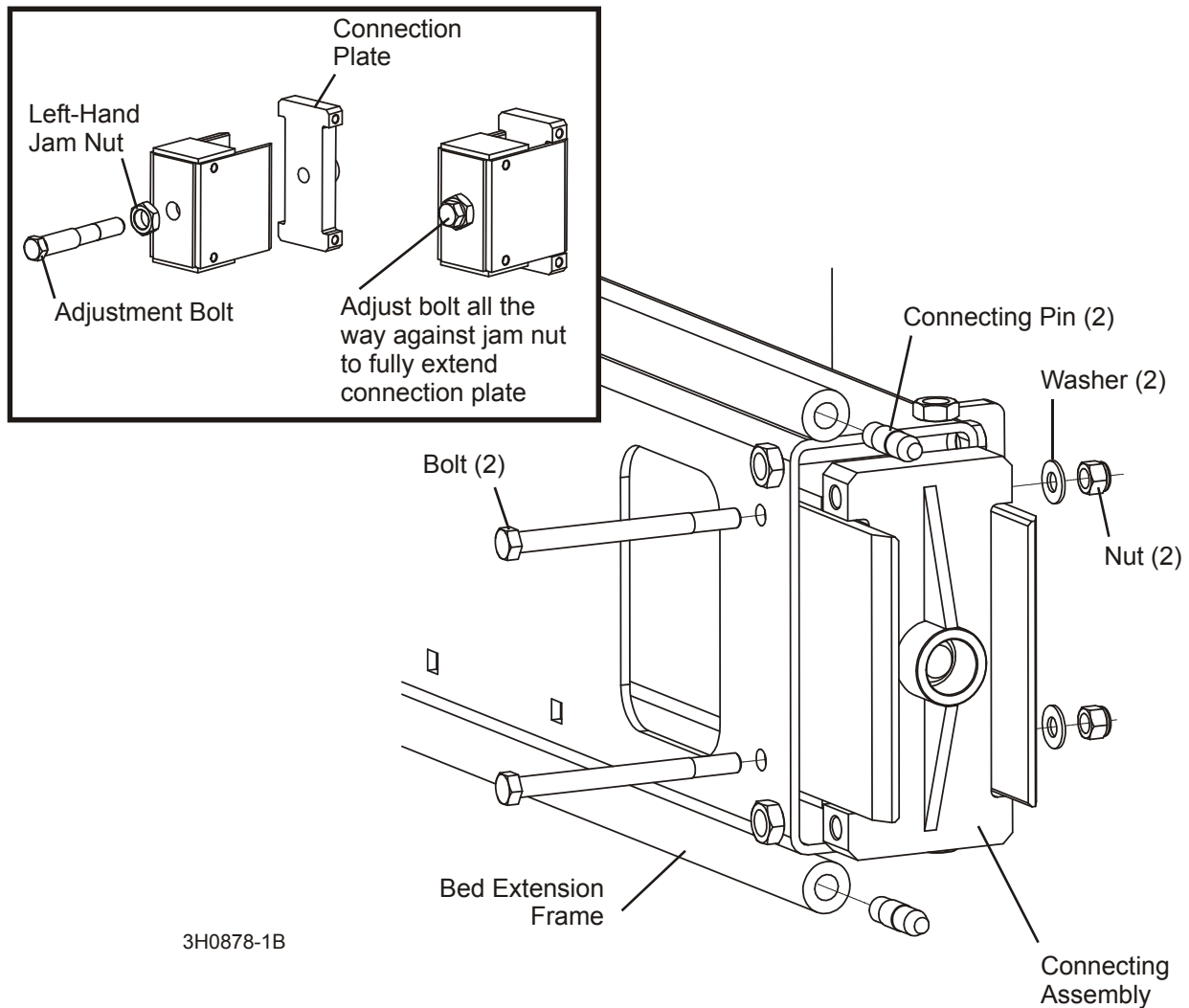


FIG. 3-6

See Figure 3-7.

- Slide the extension frame and sawmill frame together and align the connecting pins to the holes in the sawmill track rails. Shim under the feet of the extension and/or sawmill so the pins align with the holes if necessary. Push the frames together until the mounting holes in the connecting assembly align with the holes in the sawmill frame tube. Secure with the remaining two mounting bolts, flat washers and lock nuts.

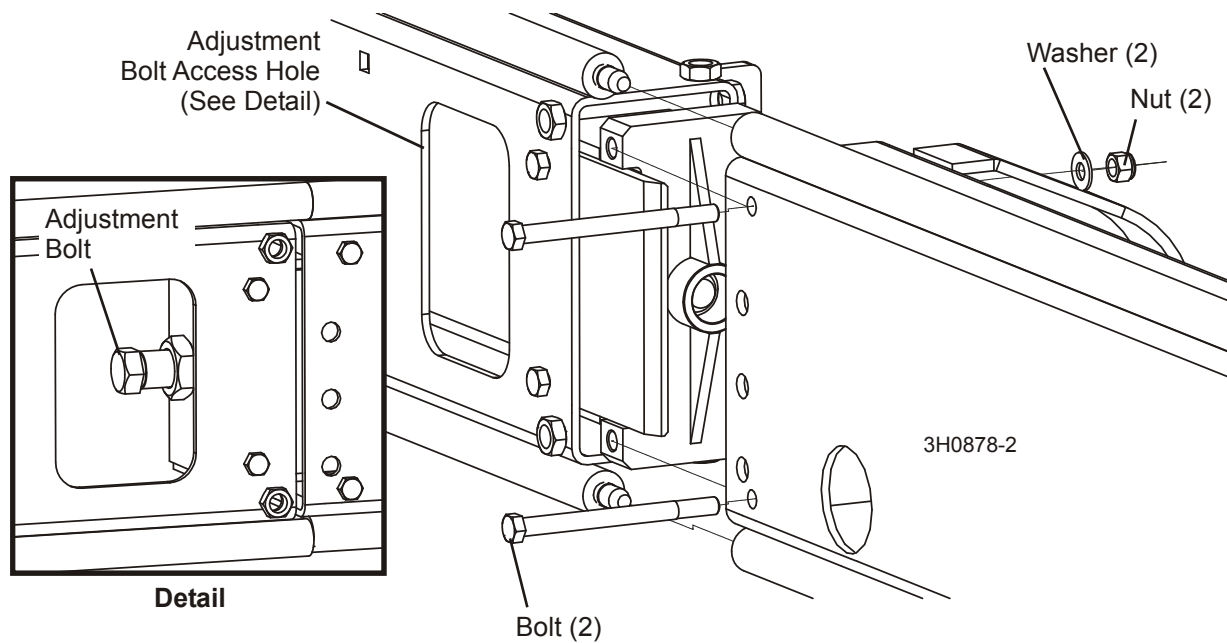


FIG. 3-7

Turn the adjustment bolt clockwise to draw the extension and sawmill frames together until the track rails are touching snugly. Tighten the adjustment bolt jam nut.

# 3

## Setup

### Extension Frame Installation (BX6/BX10)

See Figure 3-8.

5. Mount the support brace tube between the sawmill and extension frame. Use four 3/8-16 x 1 1/4" bolts and lock nuts to secure the brace to the extension frame.
6. Attach the brace to the sawmill frame using two bolts and lock nuts. Place the appropriate combination of shims between the brace and frame to fill any gap between the two.
7. **BX6 Only:** Install a single leg mount to the brace using four 3/8-16 x 1 1/4" hex head bolts and lock nuts. Install a foot to the leg mount as described above.

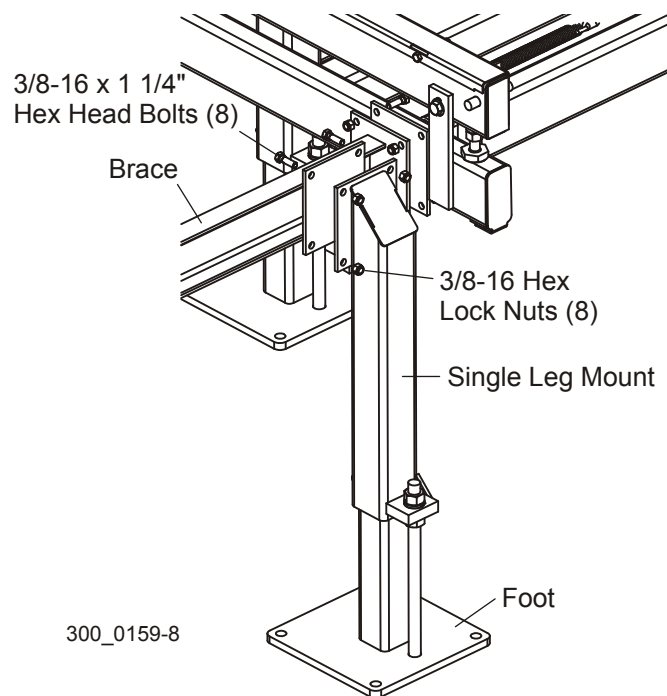


FIG. 3-8

8. Attach the supplied length(s) of feed chain to the existing feed chain with the master link(s) provided. Connect the feed chain to the feed stop bracket at the end of the extension frame. Adjust the feed chain tensioner so that the chain is positioned 12 1/2" - 13 1/2" from the top track rail at its lowest point. Make sure the feed chain is not twisted or kinked.
9. Place two equal height objects on top of the track rail (wrench sockets work well). Pull a string tight over the objects and clamp so there is no sag in the string. Measure from the string to the track at one end, the middle, and the other end of the track. The track should be 1/16 to 1/8" (1.5 to 3.0 mm) higher in the middle than at the ends. This will compensate for any sag that occurs as the cutting head reaches the middle of the track. If more bow in the middle is needed, shim the middle track-mounted legs. If the middle is bowed up too much, shim the track-mounted legs at each end of the frame. Shim under any feet that do not touch the ground.



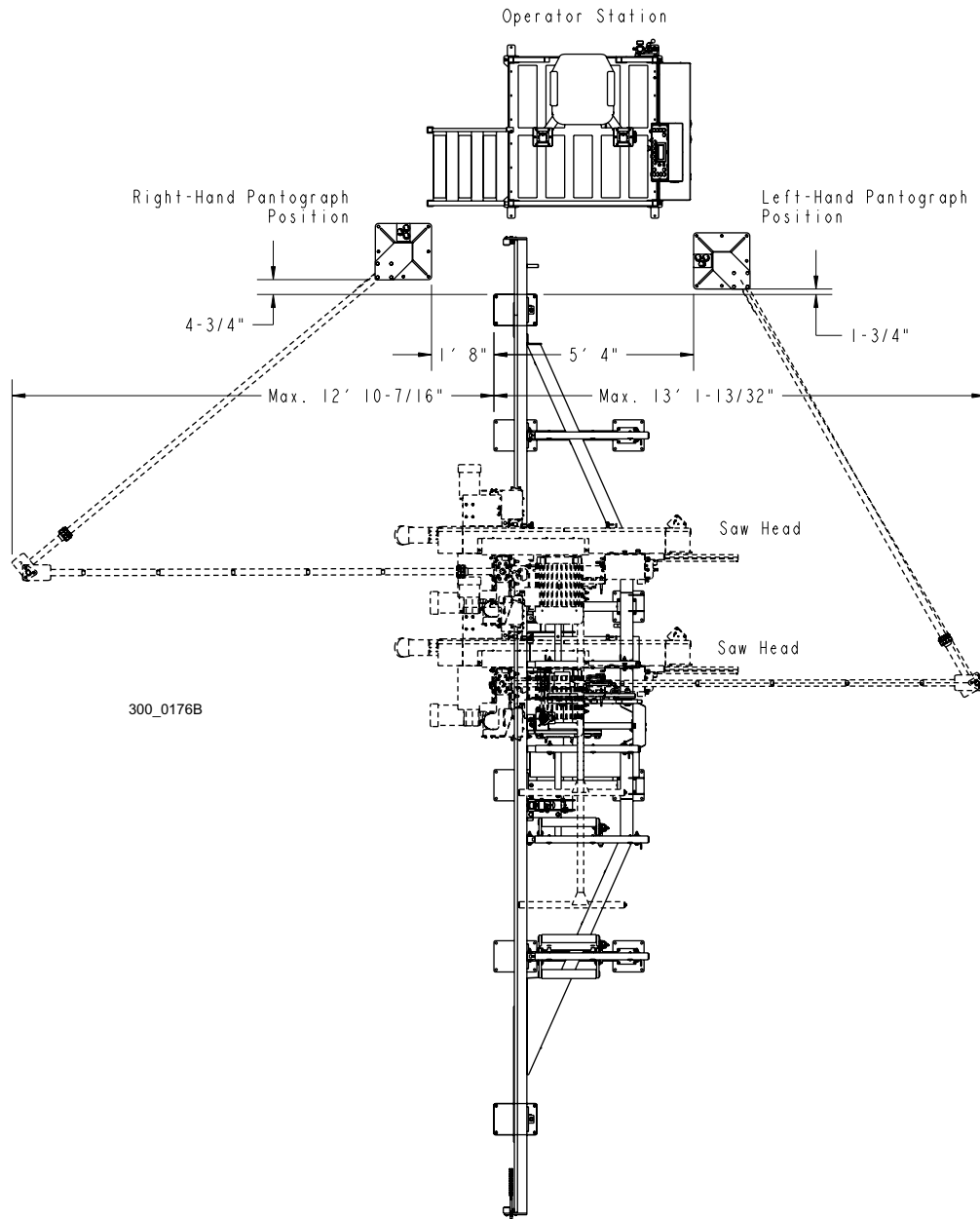
A manual log clamp is supplied with the bed extension to help clamp long logs against the side supports.

1. Insert the log clamp post in the slotted channel between the middle bed rails of the extension. Choose a hole close to the log.
2. Pull the clamp handle to spin the cam against the log and clamp the log firmly against the side supports.
3. Lock the clamp in place with the chain mounted to the extension frame. Stretch the chain up to the clamp and slip the chain through the slot on the clamp handle. Use a link in the chain that holds the clamp firmly against the log.

### 3.5 Pantograph Cable Boom

**IMPORTANT!** Make sure there is enough room around the sawmill for the pantograph movement after the pantograph assembly installation is complete.

See **Figure 3-9**. Position the pantograph in position. For LT300 sawmills without bed extension option, select one of the right-hand or left-hand alternate positions for the pantograph main tube installation. (NOTE: The assembled pantograph is shown below.)



**FIG. 3-9 LT300**

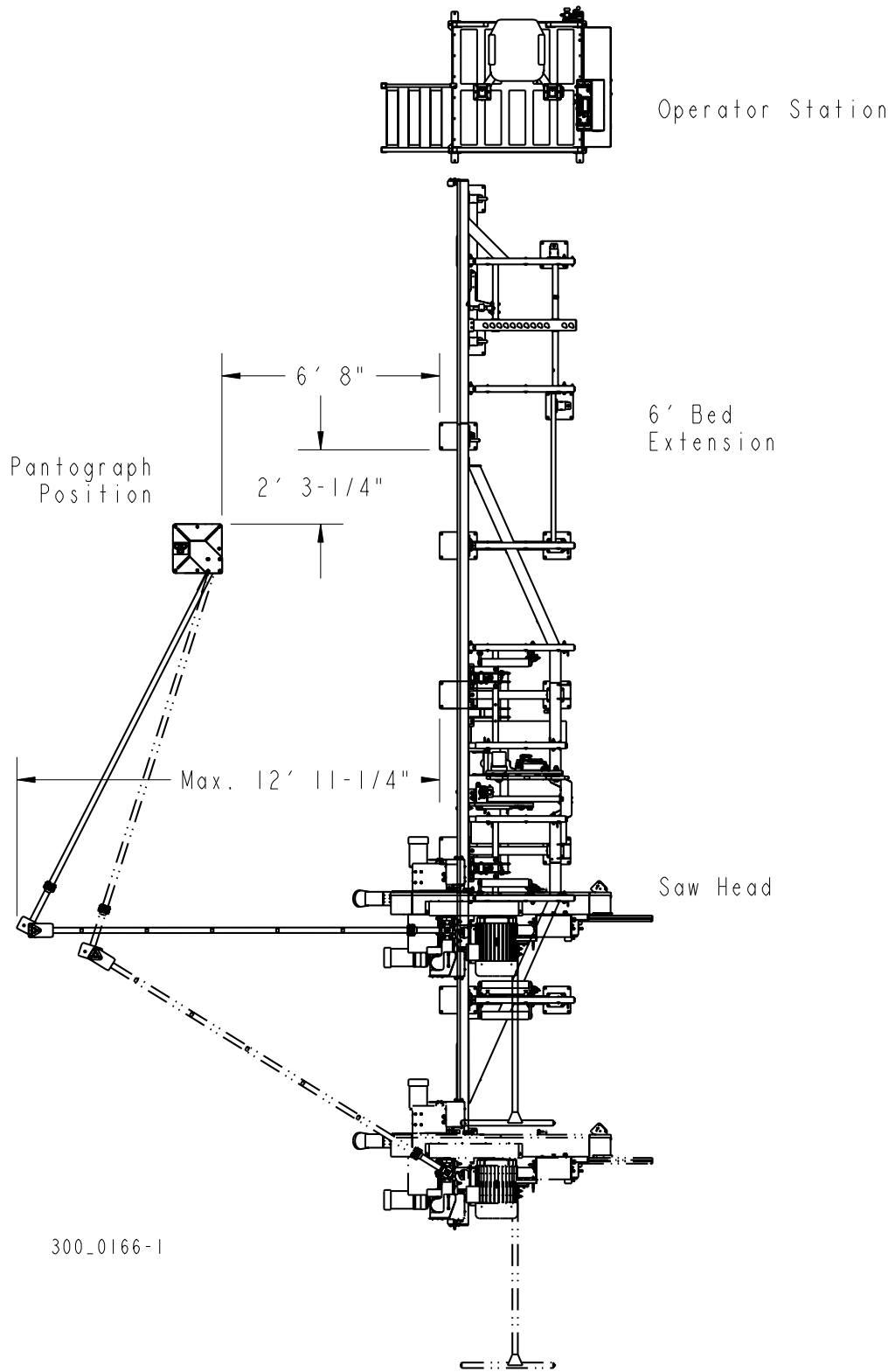
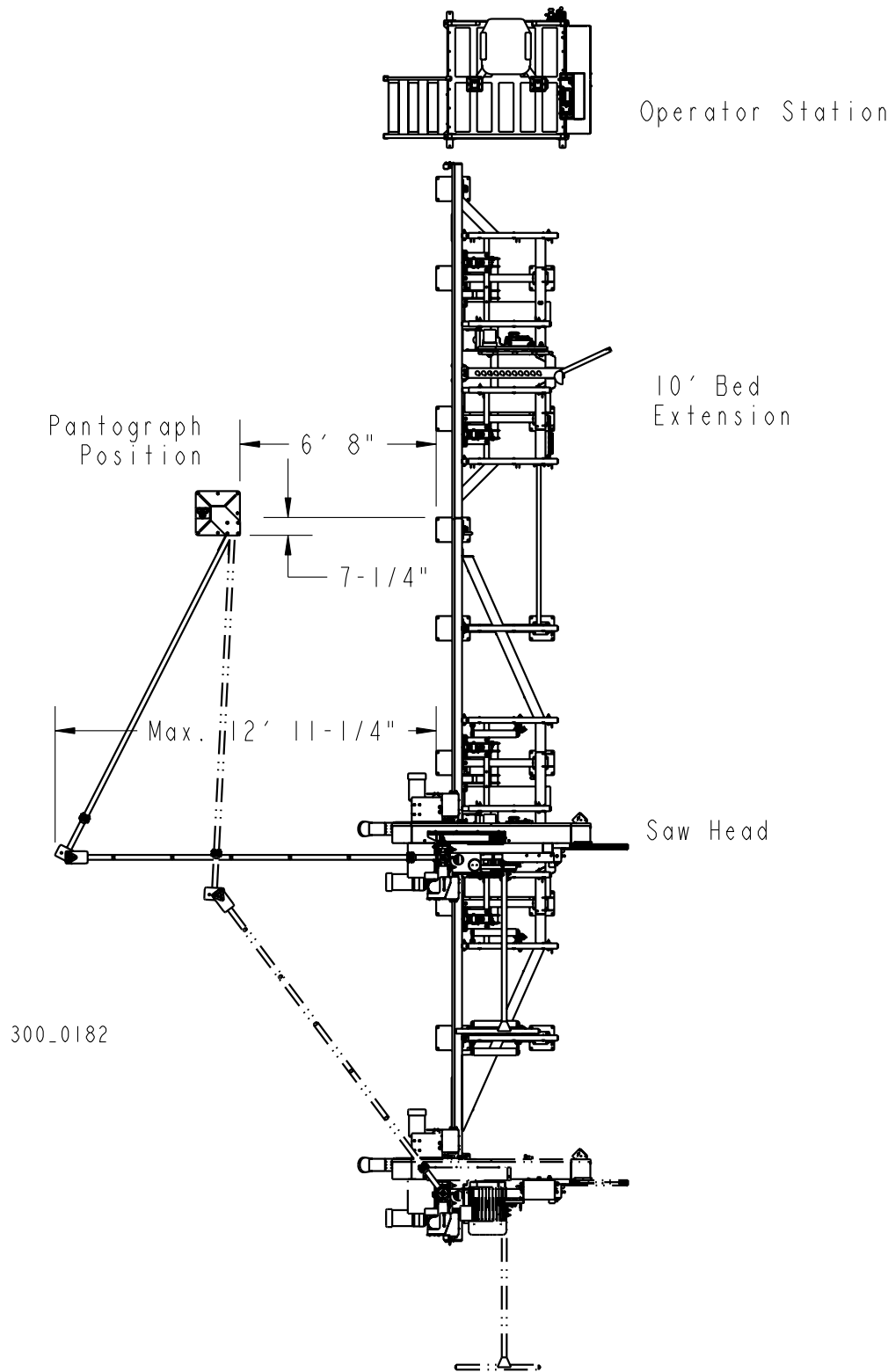


FIG. 3-9 LT300-BX6

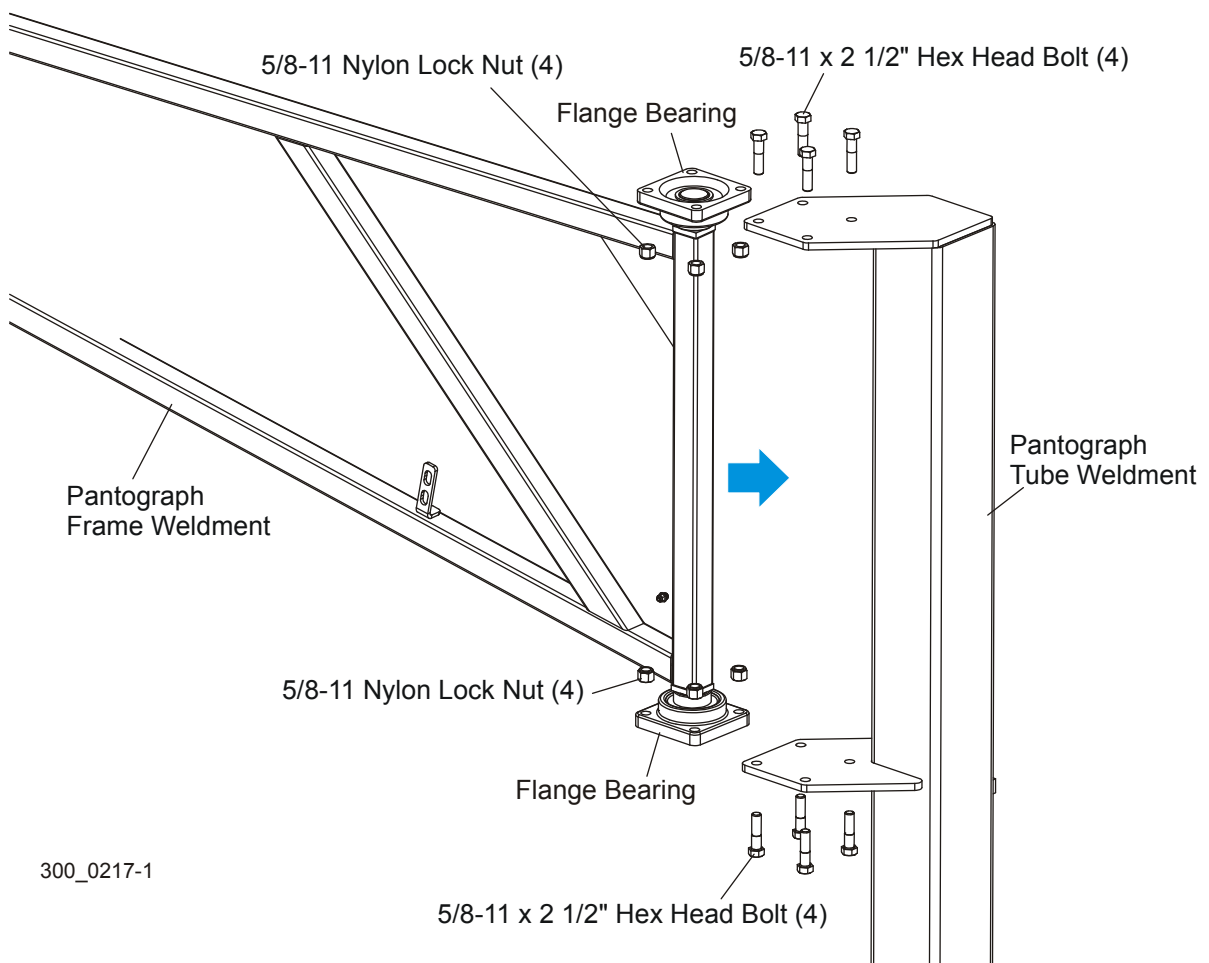
**3** Setup  
*Pantograph Cable Boom*



**FIG. 3-9 LT300-BX10**

4. Secure the pantograph main tube weldment to the ground with eight anchor bolts. A cement pad with 1/2" diameter anchor bolts is recommended.
5. Install the pantograph frame weldment to the main tube. Install the two provided flange bearings to the upper and lower pivot ends on the frame weldment. Use the provided 5/8-11 x 2 1/2" hex head bolts and 5/8-11 nylon lock nuts to secure the frame weldment to the main tube.

**See Figure 3-10.**



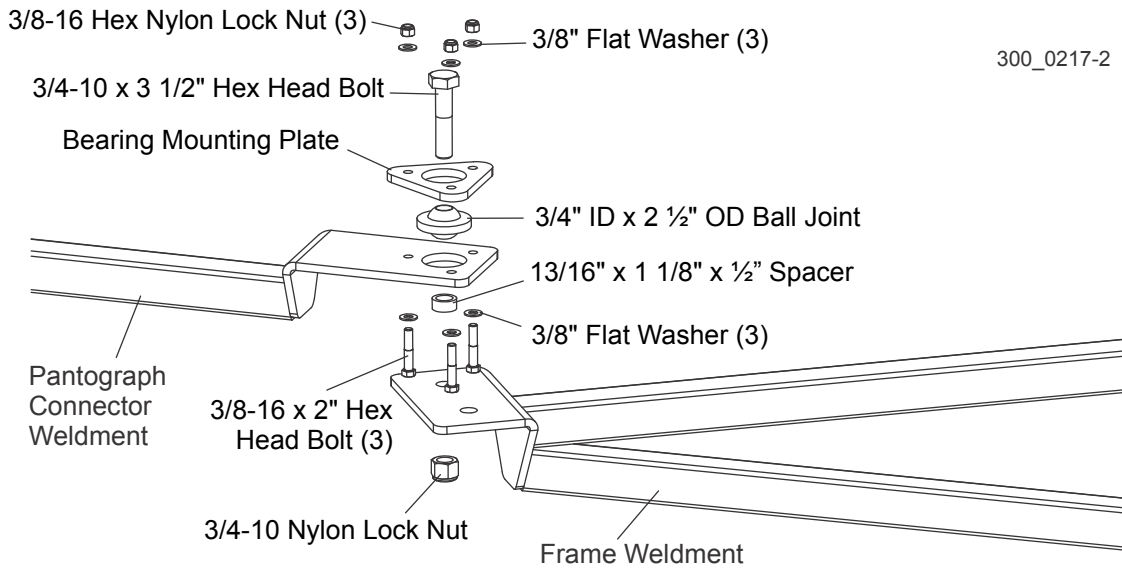
**FIG. 3-10**

# 3 Setup

## Pantograph Cable Boom

6. Install the connector weldment to the end of the frame weldment as shown below. Use the provided parts to make the required connection.

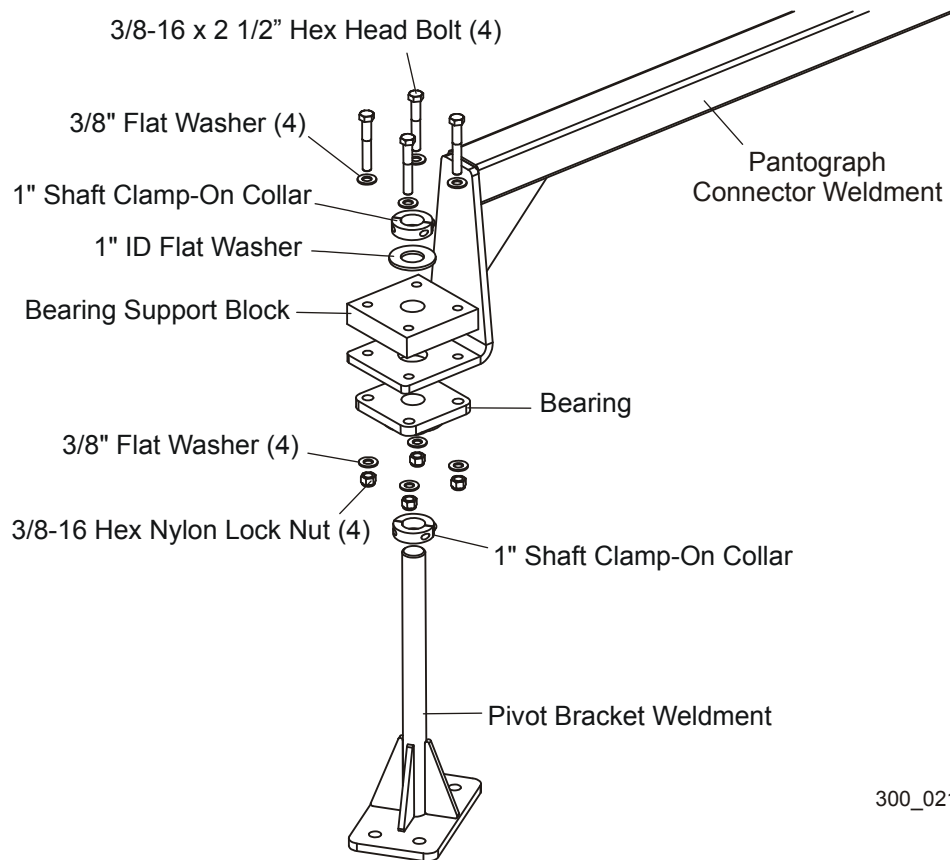
See Figure 3-11.



**FIG. 3-11**

7. Install the pantograph pivot bracket to the end of the connector weldment. Use the provided parts as shown below.

See Figure 3-12.



**FIG. 3-12**

### 3 Setup

#### Pantograph Cable Boom

8. Move the pantograph connector weldment so that the pivot bracket is located directly above the sawmill mast. Remove the four bolts and lock washers securing the top bellow mount plate to the sawmill mast assembly. Use the provided 1/2-13 x 1 1/2" hex head bolts and the existing lock washers to secure the pivot bracket to the mast.

See Figure 3-13.

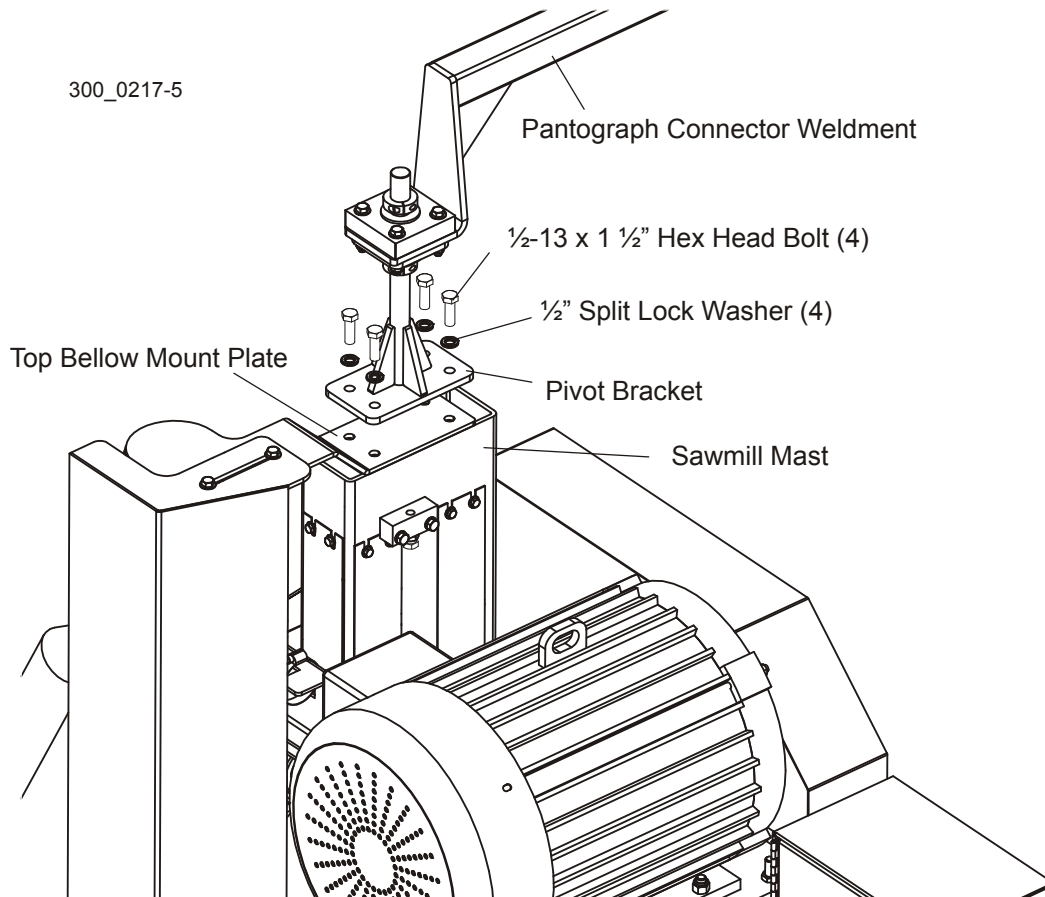
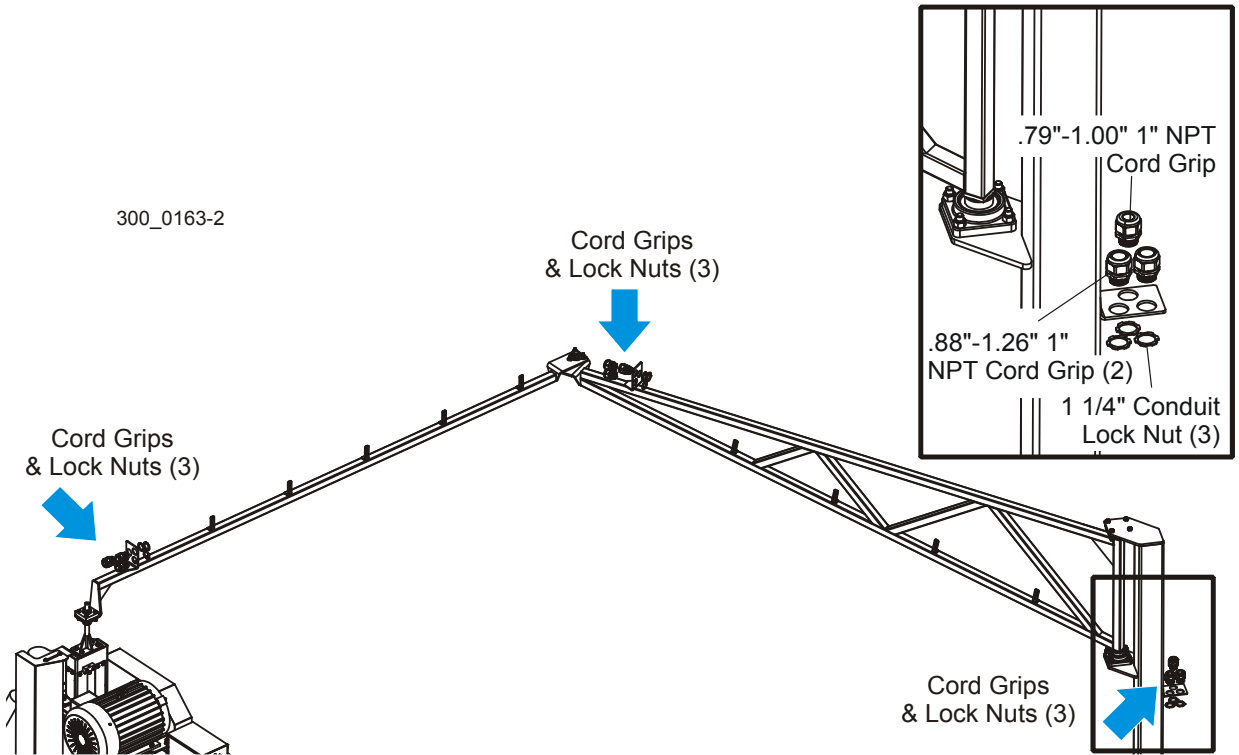


FIG. 3-13



See **Figure 3-14**. Install the provided cord grips to the three brackets located on the pantograph assembly. Secure the cord grips with the conduit lock nuts as shown.



**FIG. 3-14**

9. Route all the cables, air line and lube hose from the operator station through the cord grips on the pantograph toward the sawmill mast. **NOTE:** Route all the electrical cables through the larger cord grips. Route the air line and lube hose through the smaller cord grips.
10. Use the provided tie wraps to secure the cables, air line and lube hose to the pantograph assembly.

**IMPORTANT!** Make sure the cables, air line and lube hose are looped at each end of the pantograph weldment to avoid damage when operating the sawmill. Make a larger loop between the pantograph assembly and the saw head for the saw head up/down movement. When pantograph electrical installation is finished, move the saw head to test the pantograph movement. Readjust the loop sizes as necessary.

## 3.6 Lube Installation

### 3.6.1 Standard Lube System (Rev. A9.05+)

**NOTE:** If your LT300 is equipped with the optional Pressure Lube System, [See Section 3.6.3](#).

The blade lubrication system consists of a 55-gallon drum, filter, pump and all necessary fittings and hoses. A 5-gallon auxiliary tank is included that allows you to add vegetable oil to the lube water during operation. Using vegetable oil in the lube increases blade life and performance.

**See Figure 3-15.** The auxiliary tank can be mounted to the back of the operator's station using the hardware provided:

**Without cab option:** Use two 3" bolts, flat washers and lock nuts and one 1 1/2" bolt to mount the tank tray to the operator's station frame.

**With cab option:** Use two 1 1/2" bolts to mount the tank tray to the operator's station frame. Use two flat washers as spacers between the left bolt and cab wall.

The lube pump may be relocated to the auxiliary tank tray. Four 1" bolts, flat washers and lock nuts are provided for this purpose.

The lube system can also be positioned in a remote location up to 90' away from the saw-mill. If a remote position is desired, use your own hardware to mount the auxiliary tank on

a wall approximately 20" above the drum and mount the pump to the tray.

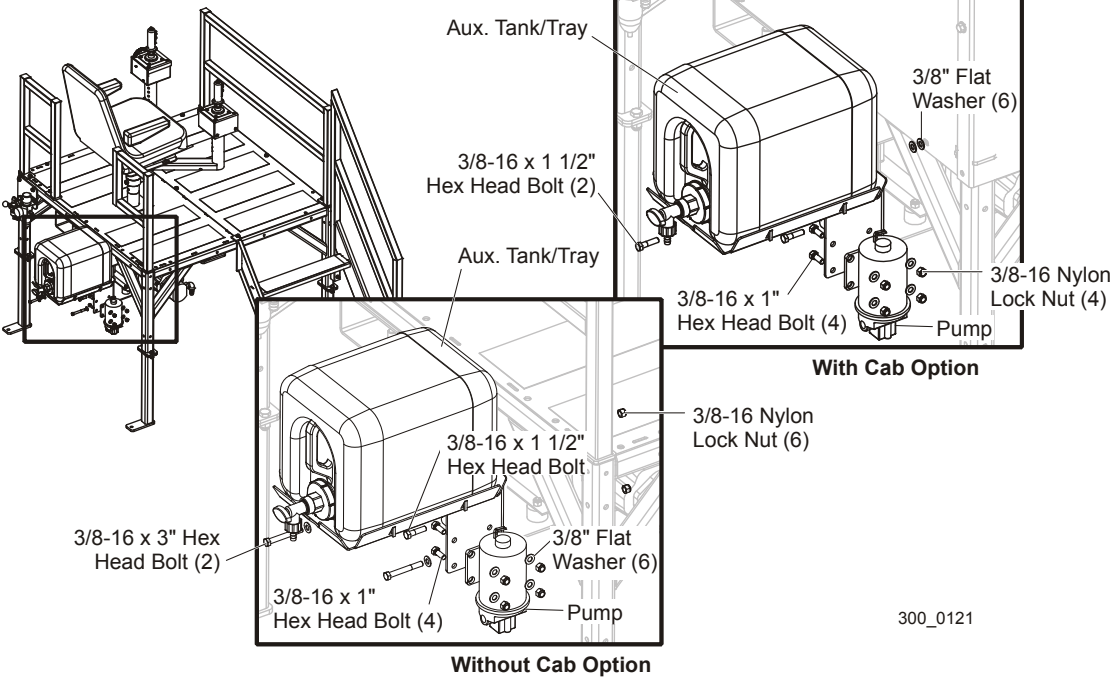


FIG. 3-15

# 3

## Setup

Standard Lube System (Rev. A9.05+)

**See Figure 3-16.** Connect the large hose from the filter to the large fitting on the pump and secure with the provided hose clamp. Connect the small hose from the valve to the small 'T' fitting on the pump. Push the fitting collar in, insert the hose and release the collar. Connect the electric cable to the pump harness, route it to the electrical cabinet at the operator station and connect the wires ([See Section 3.7.6](#)). Connect the lube hose from the sawmill blade guides to the 'T' fitting on the pump.

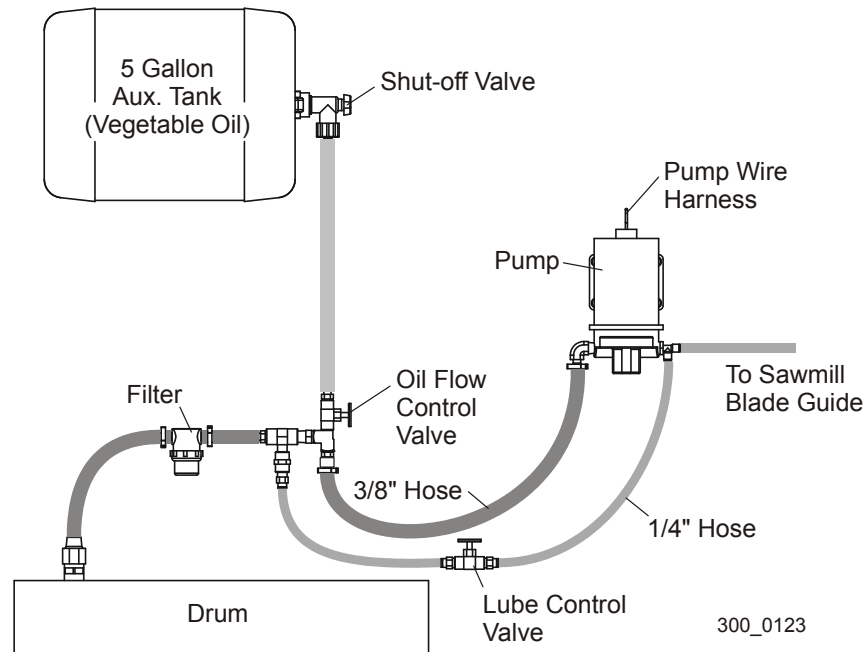
Remove the fill cap from the drum and fill with water. Replace the fill cap.

Fill the auxiliary tank with any inexpensive cooking/vegetable oil. Wood-Mizer has found soybean oil to be inexpensive and performs well. In cold temperatures, vegetable oil tends to gel. If temperatures are cold enough to cause the oil to thicken, dilute the oil at a ratio of 50:1 with a pour point depressant such as EverFlow #107671A.

Open the shut-off valve on the auxiliary tank all the way. Open the oil flow control valve 1/4-turn. Use the lube control valve to control volume of water/oil solution to the blade guides. Experiment with different valve settings to achieve the best performance depending on species being cut. Oil usage should be approximately 2-4 qts. per 8 hour shift.

When finished sawing, close the shut-off valve on the auxiliary tank and run the blade for 30 seconds with water only to flush the system and prevent oil from gumming the nozzles when not operating.

Immediately fix any leaks and wipe up any oil spills. Oil will collect sawdust and will be difficult to cleanup after it gels.



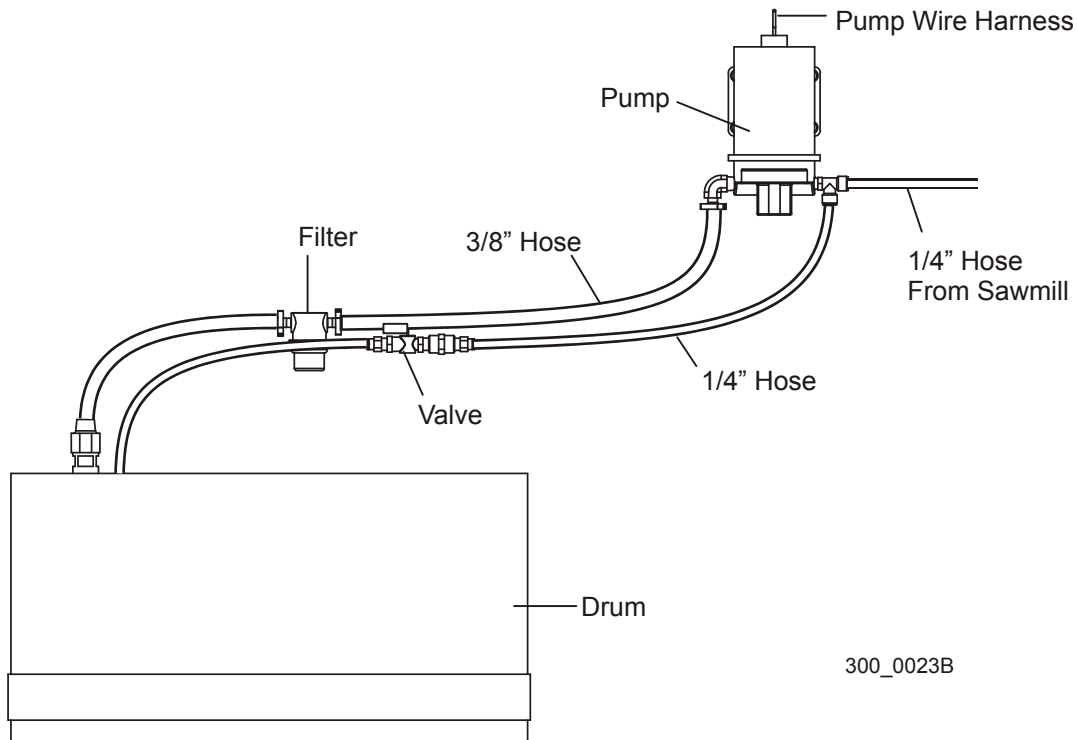
**FIG. 3-16**

**3.6.2 Standard Lube System (Rev. A1.00 - A9.04)**

**NOTE:** An auxiliary 5-gallon tank was added after this revision to allow the operator to mix vegetable oil into the lube water to increase blade life and performance. To retrofit previous revisions, use kit #038558 ([See Section 3.6.1](#)).

**See Figure 3-17.** The blade lubrication system consists of a 55-gallon drum, filter, pump and all necessary fittings and hoses. The drum may be placed at any convenient location around the sawmill within 90 feet of the operator station. Mount the filter to the wall above the drum. Connect the large hose from the filter to the large fitting on the pump and secure with the provided hose clamp. Connect the small hose from the valve to the small 'T' fitting on the pump. Push the fitting collar in, insert the hose and release the collar. Connect the electric cable to the pump harness, route it to the electrical cabinet at the operator station and connect the wires ([See Section 3.9.7](#)). Connect the lube hose from the sawmill blade guides to the 'T' fitting on the pump.

Remove the fill cap from the drum and fill with water. Add 2 1/2 gallons of AWMV lube additive. Replace the fill cap and open the valve.



**FIG. 3-17**

# 3 Setup

## Optional Pressure Lube System

### 3.6.3 Optional Pressure Lube System

**NOTE:** If your LT300 is equipped with the standard Lube System, [See Section 3.6.1.](#)

The optional pressure lube system consists of a unit mounted at the back of the operator station where a water supply line can be connected. A 2-gallon reservoir is included that allows you to add vegetable oil to the lube water during operation. Using vegetable oil in the lube increases blade life and performance.

**See Figure 3-18.** Connect a water supply hose to the water line fitting. Connect the 1/4" hose from the sawmill blade guide to the 1/4" 'T' fitting below the solenoid. Connect the 1/2" hose from the blow-off assembly to the 1/2" 'T' fitting at the top of the reservoir. Route the cable from the solenoid valve to the electrical cabinet at the operator station and connect the wires ([See Section 3.7.6.](#)).

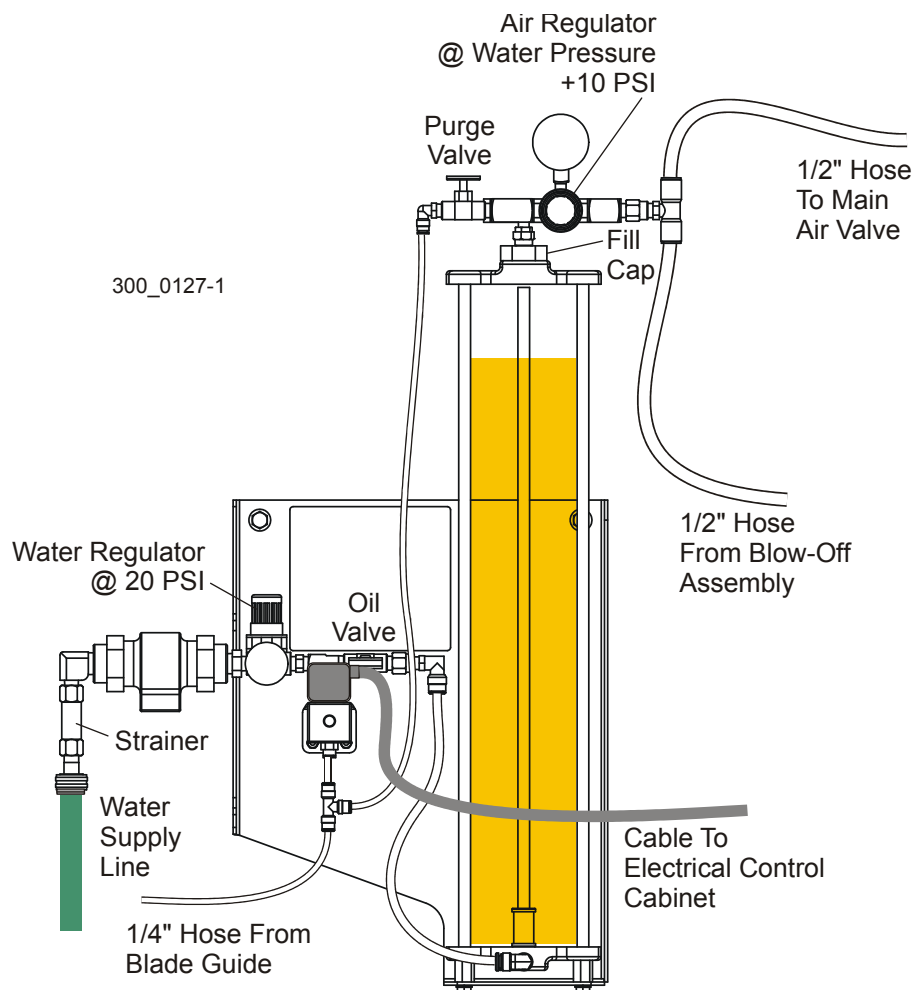


FIG. 3-18

Be sure the main air valve is closed and open the purge valve to relieve any pressure in the tank. Close the purge valve and open the fill cap. Fill the reservoir tank with any inexpensive cooking/vegetable oil. Wood-Mizer has found soybean oil to be inexpensive and performs well. In cold temperatures, vegetable oil tends to gel. If temperatures are cold enough to cause the oil to thicken, dilute the oil at a ratio of 50:1 with a pour point depressant such as EverFlow #107671A.

Turn on the water and air supply. The water regulator valve should be set at 20 PSI and can be adjusted up to 35 PSI if necessary due to water pressure. Set the air regulator valve 10 PSI higher than the water valve. Be sure the purge valve is closed during operation. Open the oil valve 1/4" turn.

Experiment with different valve settings to achieve the best performance depending on species being cut. Oil usage should be approximately 2-4 qts. per 8 hour shift.

When finished sawing, close the oil valve and open the purge valve. Run the blade for 30 seconds with water only to flush the system and prevent oil from gumming the nozzles when not operating.

Immediately fix any leaks and wipe up any oil spills. Oil will collect sawdust and will be difficult to cleanup after it gels.

Periodically clean the water strainer. With the water supply off, unscrew the strainer housing, clean the strainer and reassemble.

### 3.7 Electrical Installation

#### 3.7.1 LT300 Rev. B3.00+



**DANGER!** Make sure all electrical installation, service and/or maintenance work is performed by a qualified electrician and is in accordance with applicable electrical codes.

#### Electrical Requirements

The sawmill identification plate including the required electrical information is shown below:

MFG BY: WOOD-MIZER LLC, 8180 W. 10th St. Indianapolis, IN 46214-2400 317/271-1542 or 800/553-0182											
SERIAL #	<b>LT300 0103002A1.00</b>	FLA OF LARGEST LOAD	<b>39</b>								
FLA	<b>63</b>	IR	<b>2kA</b>	SCCR	<input type="text"/>	VOLTS	<b>480</b>	HZ	<b>60</b>	PH	<b>3</b>
	<small>(Base unit only)</small>										
ELECTRICAL DIAGRAM #	<b>1014</b>	PATENTS	<input type="text"/>			<small>S20038</small>					
<small>300_0003C</small>											

#### LT300 IDENTIFICATION PLATE

**IMPORTANT!** The sawmill is wired for use with a 480 volt power supply. To operate the sawmill with 240V, 400V or 600V power supplies an additional transformer is required. See the table below for transformers available from Wood-Mizer. All transformers are manufactured by Square D.

See Table 3-1.

Conversion From/To	240 to 480 volts	400 to 480 volts	600 to 480 volts
Wood-Mizer Part No.	068057	068055	078214

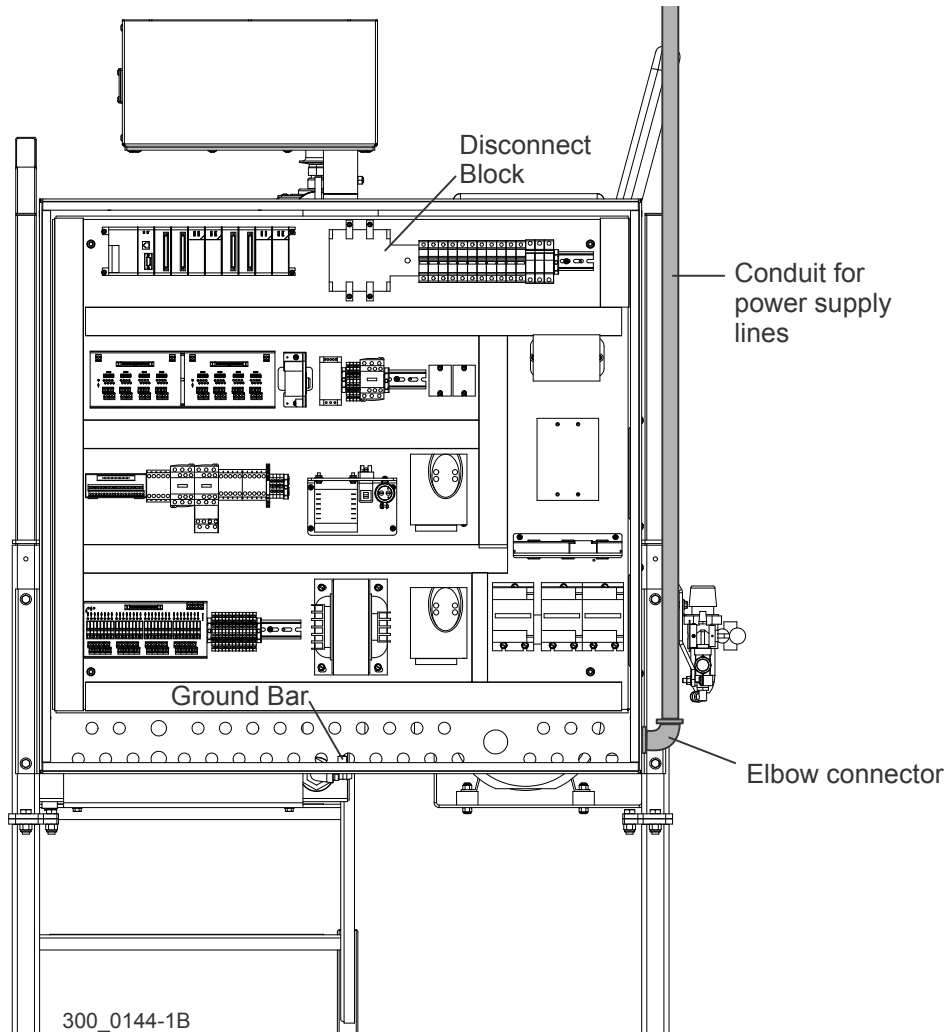
**TABLE 3-1**

**IMPORTANT!** Wood-Mizer also offers two phase generators: a phase generator without a motor starter (Part No. RPCNC40-230) and a phase generator with a motor starter (Part No. RPCNC40-230WS). These are the only supported phase generators as standard phase generators have known issues with Variable Frequency Drives. The 068057 transformer is required with the phase generator as the generator is 240VAC and has to be stepped up to 480VAC for the mill.



**Installation**

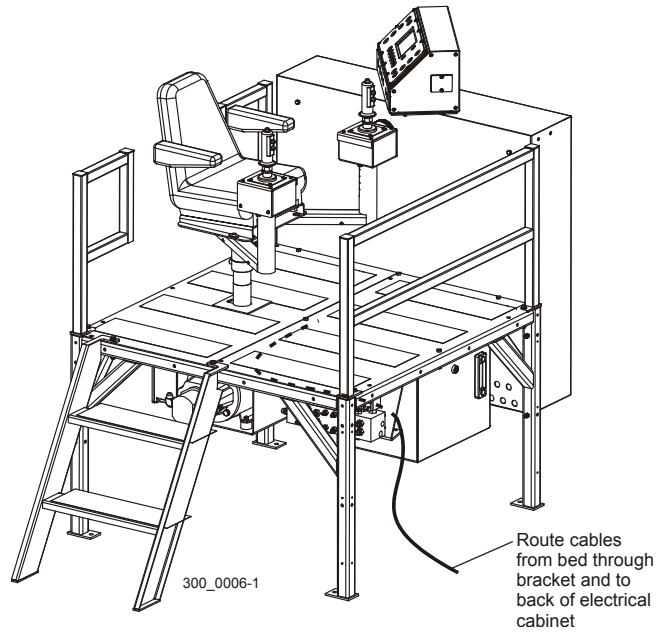
**See Figure 3-1.** Route the incoming power supply from the disconnect switch to the electrical cabinet. One recommended method is to drop conduit from the ceiling down to the hole in the right side of the cabinet, near the bottom. Install an elbow connector to secure the conduit to the cabinet. Connect the ground wire to the ground bar at the bottom of the cabinet. Route the three power lines to the disconnect block at the top of the cabinet.



**FIG. 3-1**

# 3 Setup Installation

See **Figure 3-2**. Several cables connect the sawmill controls to the components in the electrical cabinet. Route the cables under the operator station and tie wrap to the bracket as shown.



**FIG. 3-2**

See Table 3-1. Locate and identify each cable as shown in the table below.

Cable	Function	Box Entry Location <a href="#">See fig. 3-3</a>	Wire Terminal Number	Termination Location (Component ID.Terminal ID)
1	Power Feed <a href="#">See fig. 3-5</a>	P/F	500	U1.T1
			501	U1.T2
			502	U1.T3
			Ground	U1 Ground
2	Up/Down <a href="#">See fig. 3-5</a>	U/D	503	U2.T1
			504	U2.T2
			505	U2.T3
			Ground	U2 Ground
3	Up/Down Brake <a href="#">See fig. 3-6</a>	Brk	506	X4.A2
			334	X3.A2
4	Blade Motor <a href="#">See fig. 3-7</a>	25hp Mtr	1	K12.T1
			2	K12.T2
			3	K12.T3
			10	K10.T3
			11	K10.T1
			12	K10.T2
			53	X15.A2
			146	X9.2
			Ground	Grounding Bar
5	Transducer <a href="#">See fig. 3-9</a>	Trans	51	X22.B2
			52	X22.C2
			510	X21.A2
			511	X22.A2
7	Lube System <a href="#">See fig. 3-10</a>	Lube	70	K3.2
			69	Q4.2

TABLE 3-1

### 3 Setup Installation

8	Head Box <a href="#">See fig. 3-8</a>	20/16	381 (for Debarker Option)	X20.A2
			26	K7.2
			27	K7.4
			53	X17.A2
			56	X10.B2
			68	X16.B2
			132	PCB2.A0
			133	PCB2.A1
			134	PCB2.A2
			135	PCB3.D4
			139	PCB2.A7
			140	PCB2.B0
			141	PCB2.B1
			149	PCB2.B7
			200	X5.A0
			201	X5.A1
			253	PCB3.D5
254	PCB3.D6			
278	Not Used			
9	Debarker Option Foot Switch <a href="#">See fig. 3-11</a>	DBS	53	X19.B2
			378	PCB2.A5
			Ground	Grounding Bar
10	Debarker Option Motor <a href="#">See fig. 3-12</a>	DBM	21	K13.T1
			22	K13.T2
			23	K13.T3
			53	X19.A2
			379	PCB2.A6
			Ground	Grounding Bar

**TABLE 3-1**

**See Figure 3-3.** Insert each cable to the appropriate entry point in the electrical cabinet as show below. Secure each cable to the box with the provided cable connectors.

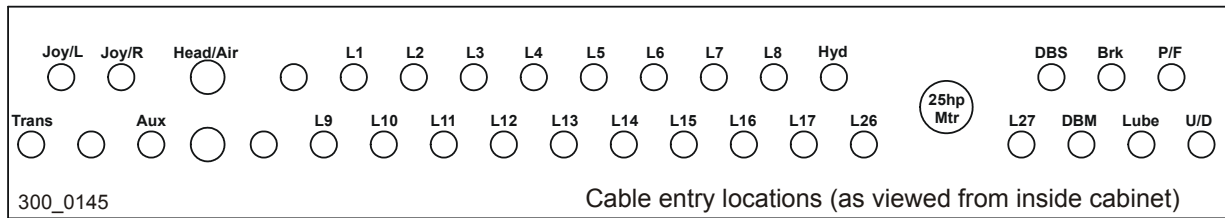


FIG. 3-3

See Figure 3-4. Route each cable to the appropriate components as described in the following instructions.

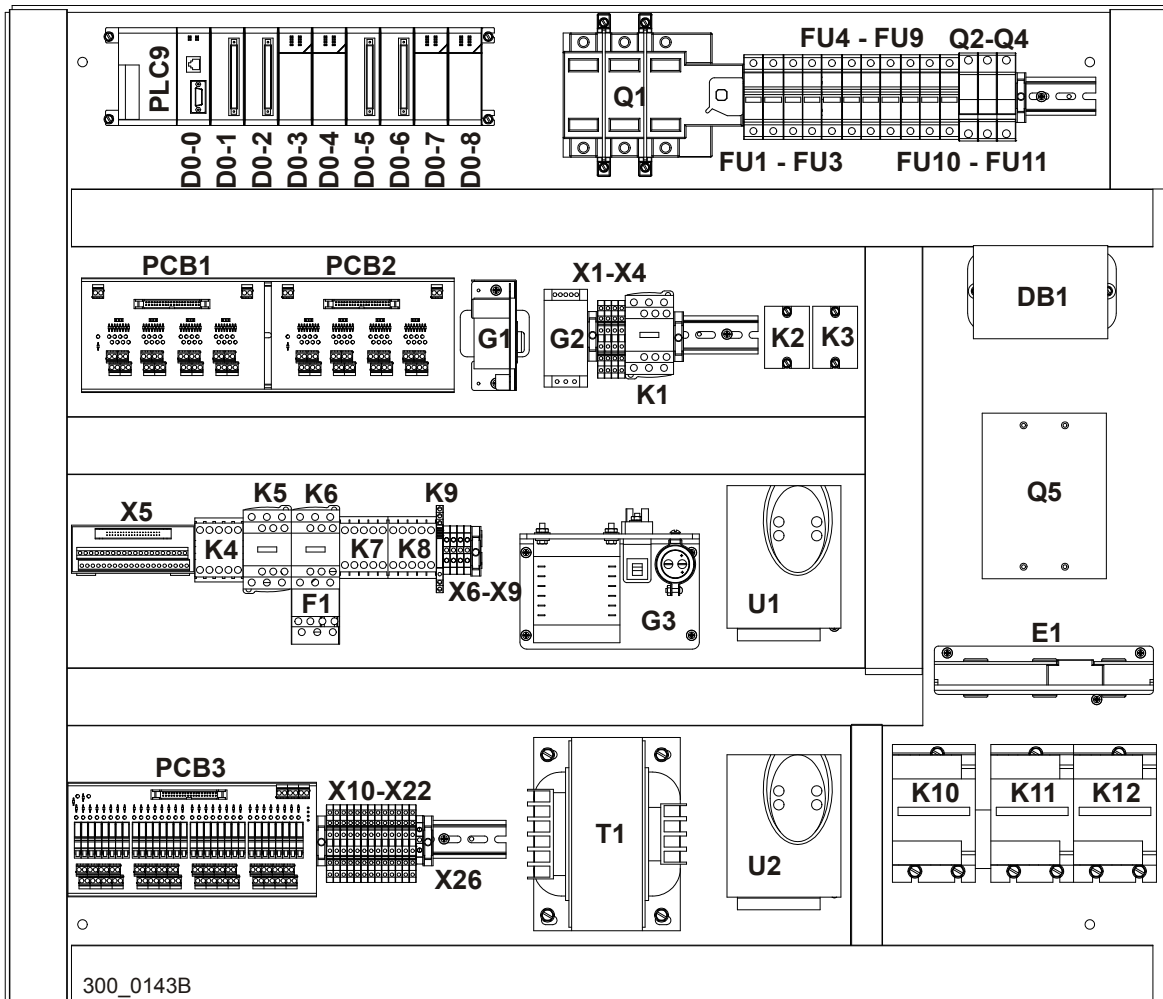


FIG. 3-4

# 3 Setup

## Power Feed & Up/Down Cables

### 3.7.1 Power Feed & Up/Down Cables

See **Figure 3-5**. Route the power feed cable through the wireways to the clamp located under A/C drive labeled U1. Fold the metal shielding over the end of the cable and insert into the clamp. Tighten the clamp to secure the cable. Repeat for the up/down cable to the A/C drive labeled U2.

Connect the power feed cable wires to A/C drive labeled U1: Connect wire #500 to terminal #T1, wire #501 to terminal #T2, and wire #502 to terminal #T3. Connect the green ground wire to the ground terminal.

Connect the up/down cable wires to the A/C drive labeled U2: Connect wire #503 to terminal #T1, wire #504 to terminal #T2 and wire #505 to terminal T3. Connect the green ground wire to the ground terminal.

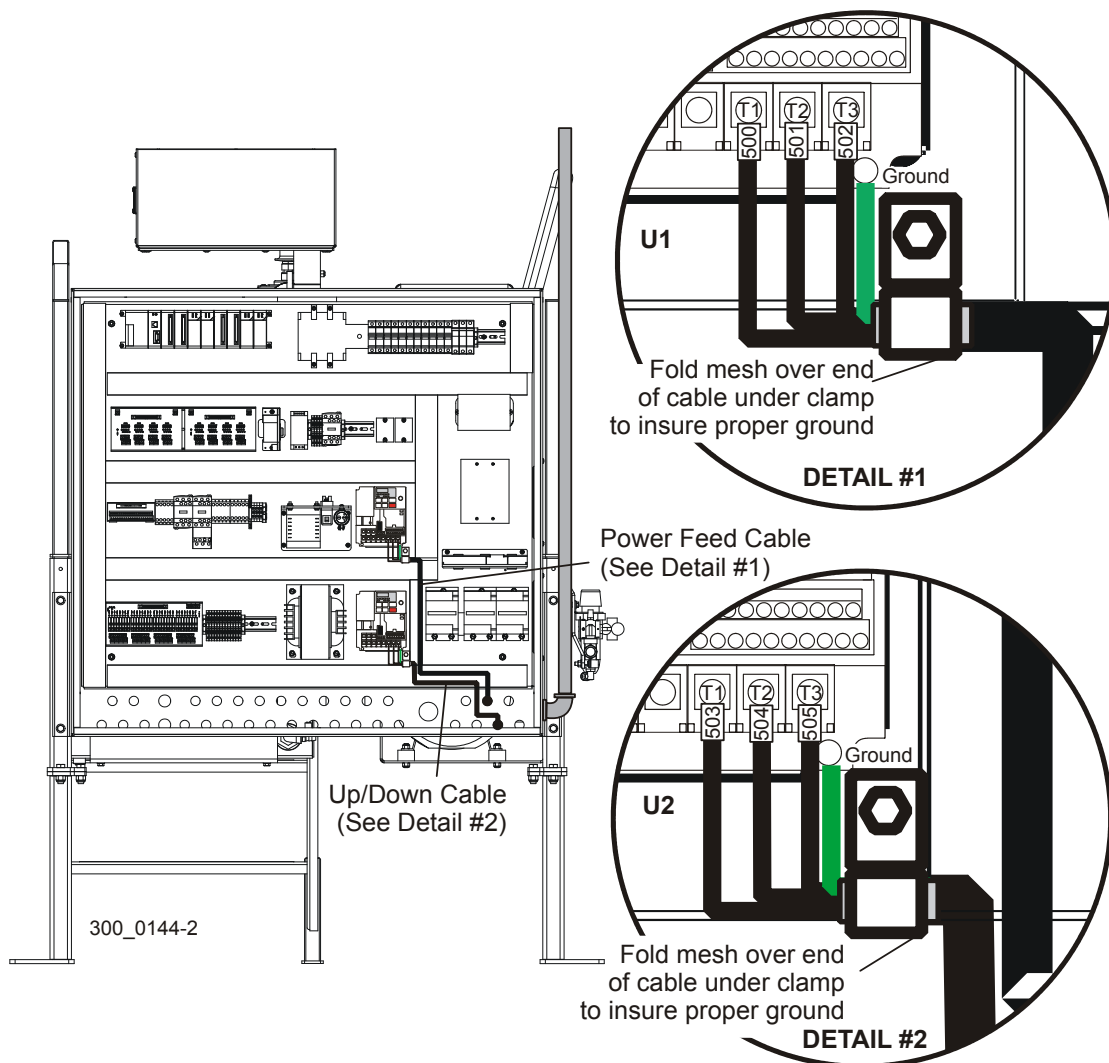
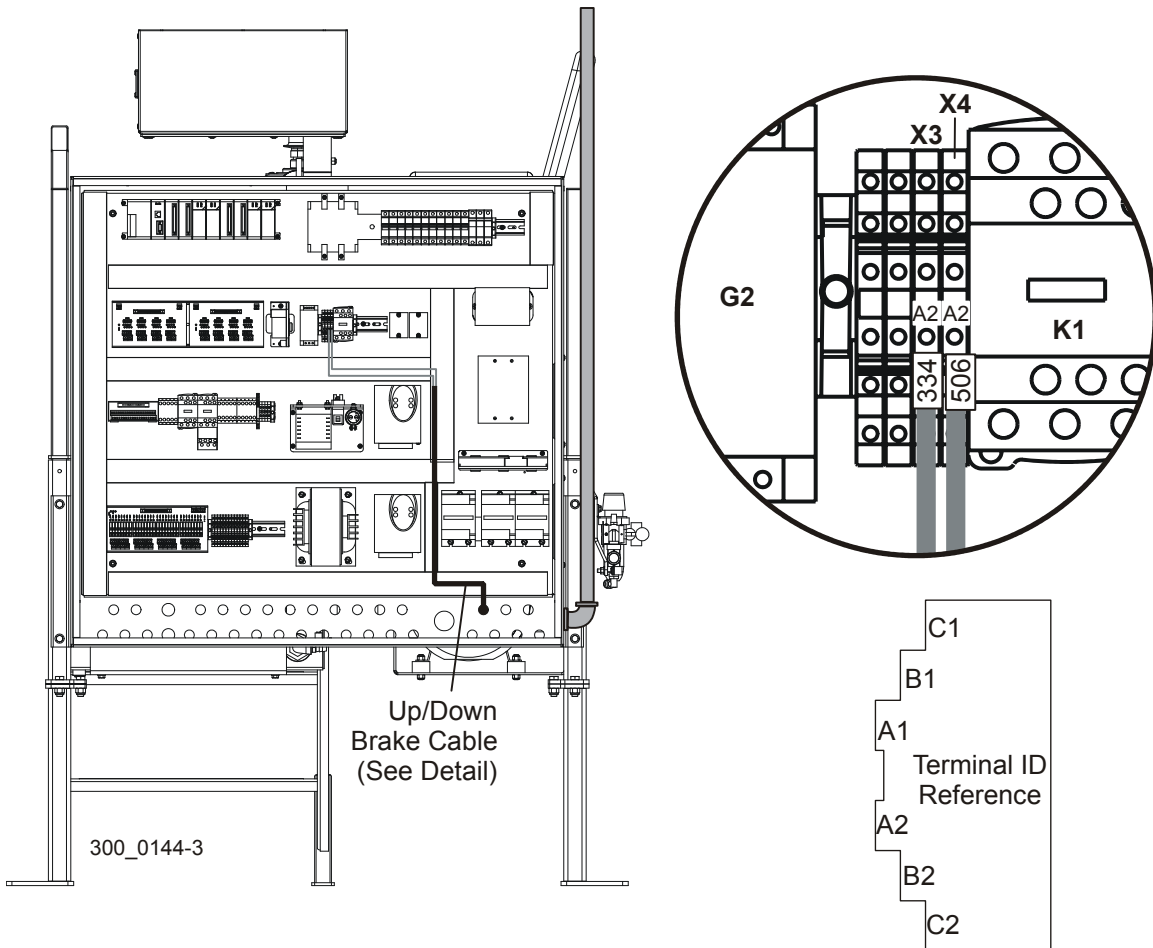


FIG. 3-5

**3.7.2 Up/Down Brake Cable**

See **Figure 3-6**. Route the up/down brake cable through the wireways to the terminal blocks X3 and X4 as shown. Connect wire #334 to terminal A2 of the terminal block labeled X3. Connect wire #506 to terminal A2 of the terminal block labeled X4.



**FIG. 3-6**

# 3 Setup

## Blade Motor Cable

### 3.7.3 Blade Motor Cable

See Figure 3-7. Route the motor cable wires with terminals labeled #1, #2 & #3 to the contactor labeled K12. Route wires with terminals labeled #10, 11 & 12 to the contactor labeled K10. Route the green/yellow striped wire to the grounding bar. Route wire with terminal labeled #53 to the terminal block labeled X15. Route wire with terminal labeled #146 to the terminal block labeled X9.

At contactor K12, connect wire #1 to terminal T1, wire #2 to terminal T2, and wire #3 to terminal T3. At contactor K10, connect wire #10 to terminal T3, wire #11 to terminal T1, and wire #12 to terminal T2. Connect wire #53 to terminal A2 of the terminal block X15. Connect wire #146 to terminal #2 of terminal block X9. Connect the ground wire to one of the ports in the grounding bar and secure with a screw.

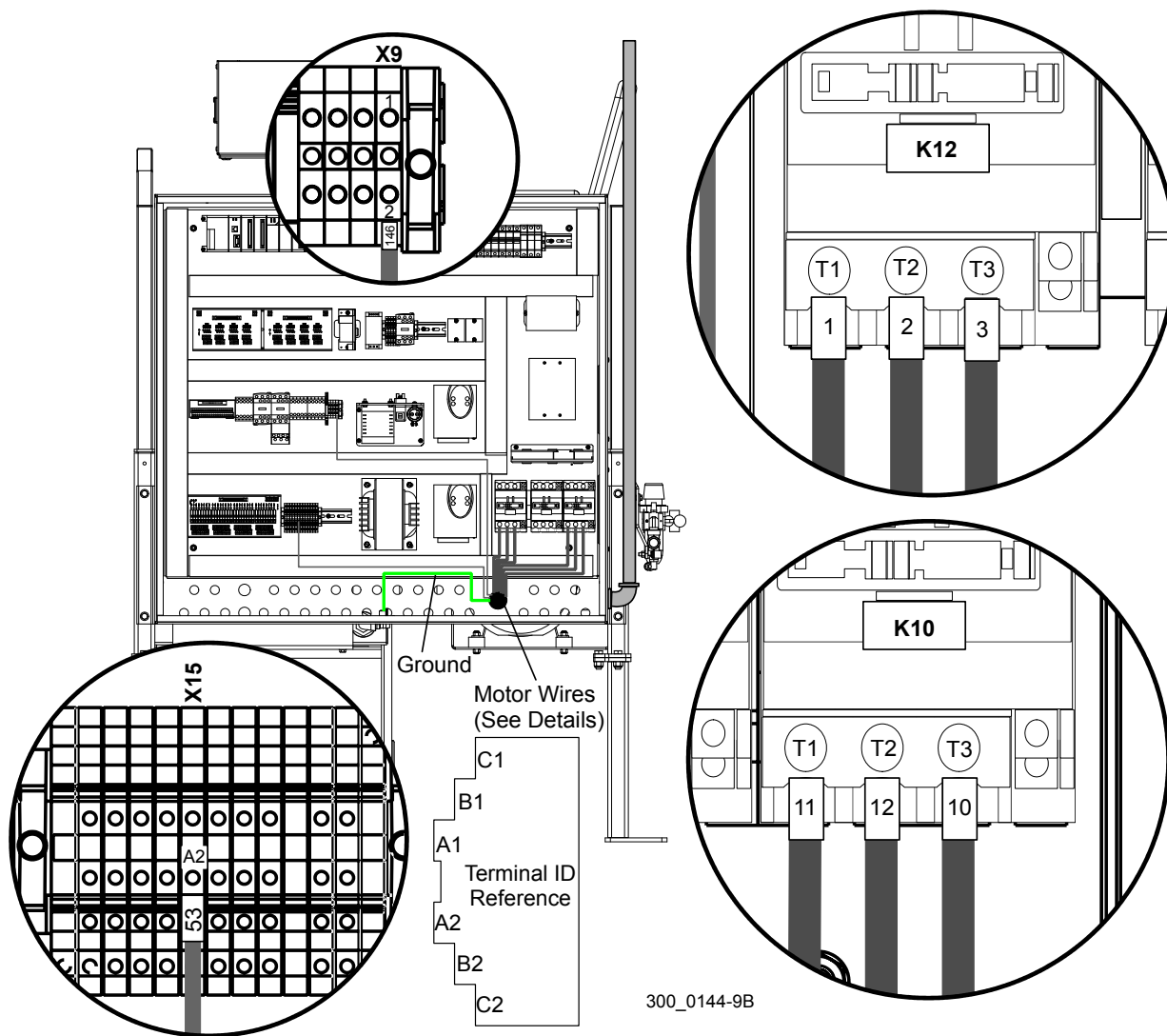


FIG. 3-7



### 3.7.4 Head Box Cable

**See Figure 3-8.** Route the head box cable wires through the wireways to the appropriate components. Route wires with terminals labeled #132, #133, #134, #139, #140, #141 & #149 to PCB2 module. Route wires with terminals labeled #53 and #56 to the terminal blocks labeled X10-X22. Route the wires with terminals labeled #200 and #201 to the terminal module labeled X5. Route the wire with terminal labeled #68 to the terminal block labeled X16. Route the wires with terminals labeled #135, #253, #254 and #278 to PCB3 module. Route the wire with terminal labeled #26 and #27 to the relay labeled K7.

At PCB2 module, connect wire #132 to terminal #A0, wire #133 to terminal #A1, wire #134 to terminal #A2, wire #139 to terminal #A7, wire #140 to terminal #B0, wire #141 to terminal #B1 and wire #149 to terminal #B7.

At block X10, connect wire #56 to terminal #B2. At block X17, connect wire #53 to terminal #A2. At PCB3, connect wire #253 to terminal D5. At block X16, connect wire #68 to terminal B2.

At connector module X5, connect wire #200 to terminal #A0 and wire #201 to terminal #A1.

At PCB3, connect wire #254 to terminal D6. At PCB3, connect wire #135 to terminal D4. At relay K7, connect wire #26 to terminal #2 and wire #27 to terminal #4 (leave existing wires connected).

### 3 Setup Head Box Cable

**Debarcker Option Only:** Route wire #381 to terminal block X20 and connect to terminal A2.

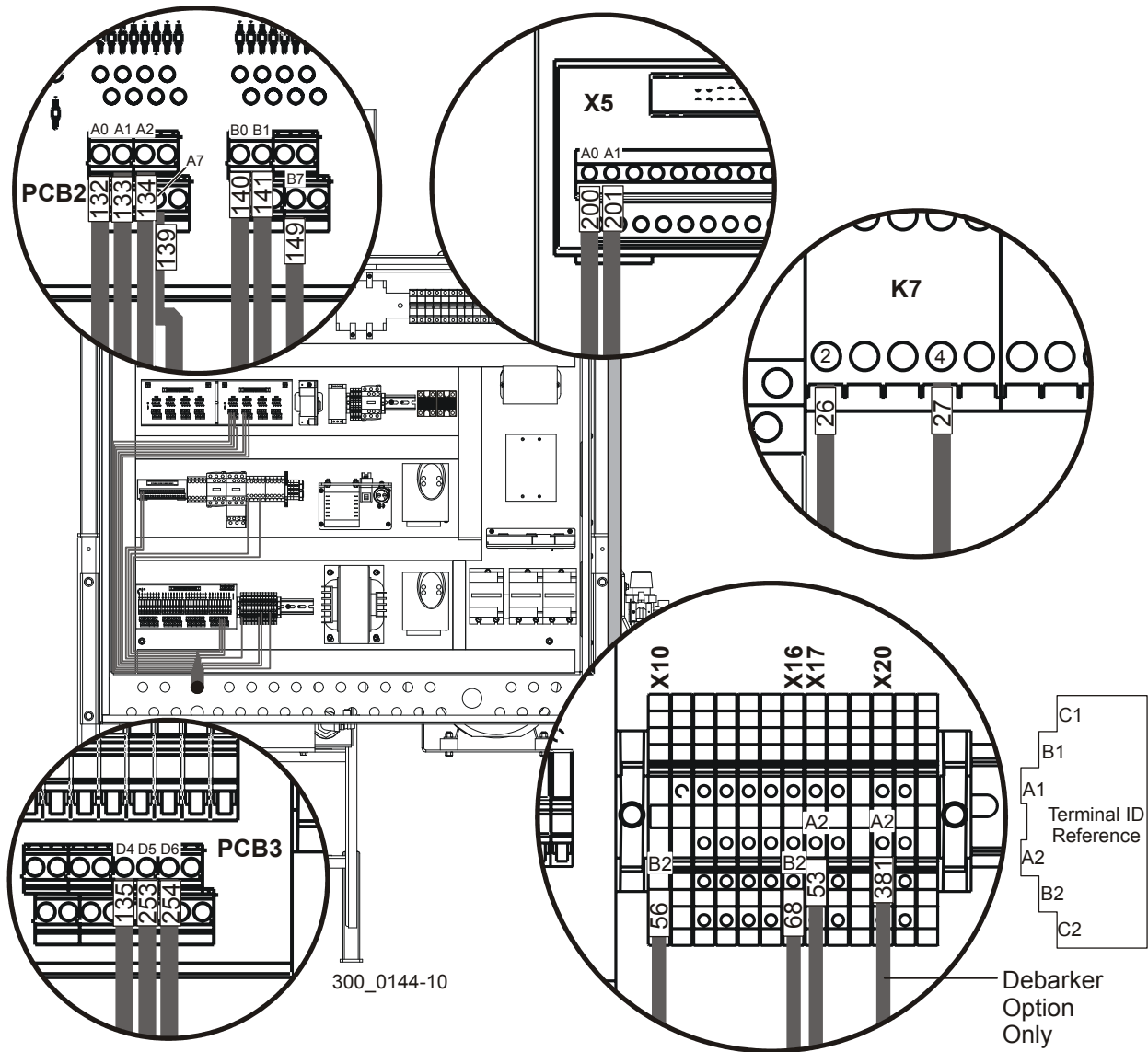
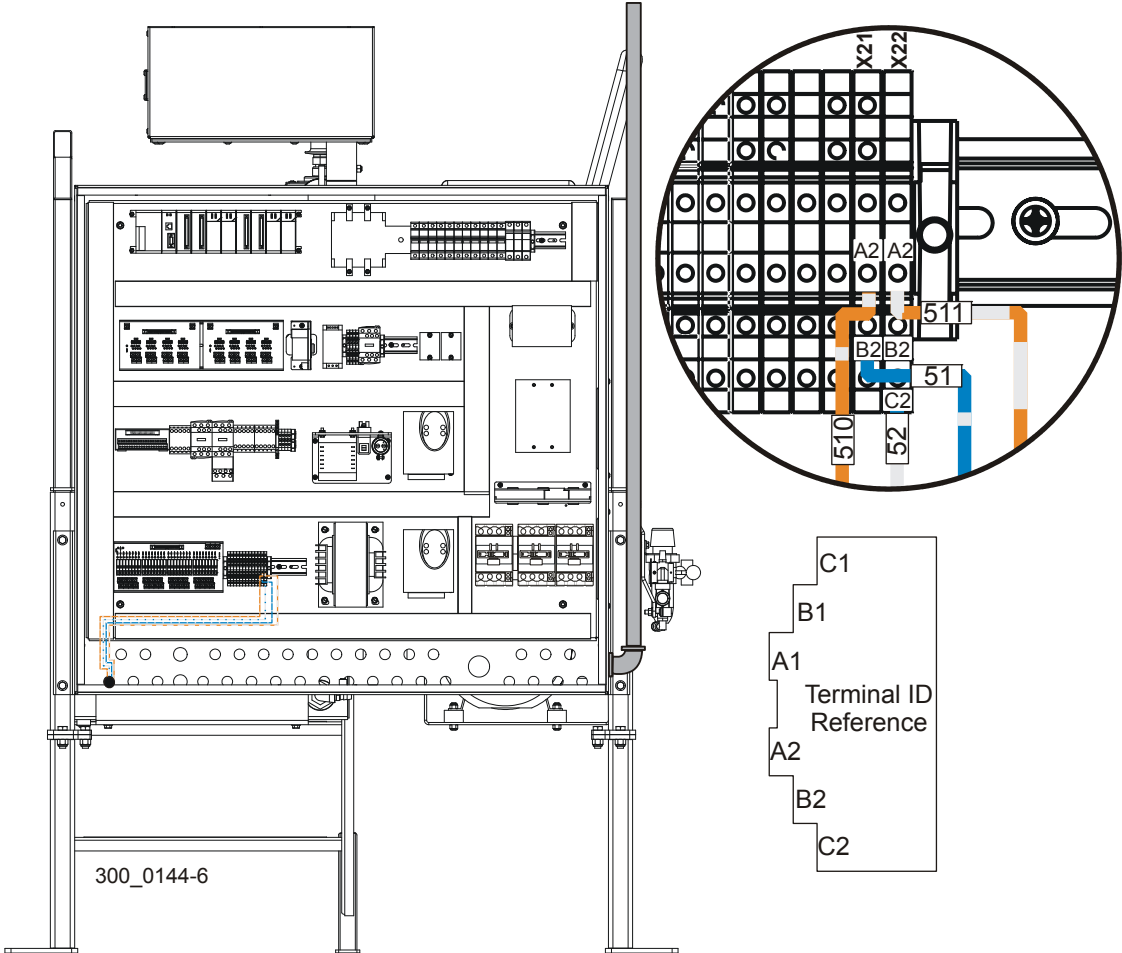


FIG. 3-8

**3.7.5 Transducer Cable**

See **Figure 3-9**. Route the transducer cable through the wireways to the terminal blocks labeled X21 and X22.

At block X21, connect wire with terminal labeled #51 to terminal #B2 and wire #510 to terminal #A2. At block X22, connect the wire with terminal labeled #52 to terminal #C2 and wire #511 to terminal #A2.



**FIG. 3-9**

# 3 Setup

## Lube System Cable

### 3.7.6 Lube System Cable

See **Figure 3-10**. Route the lube system cable wires through the wireways to the relay labeled K3 and the breaker labeled Q4.

Connect wire #70 to relay K3, terminal #2. Connect wire #69 to breaker Q4, terminal #2.

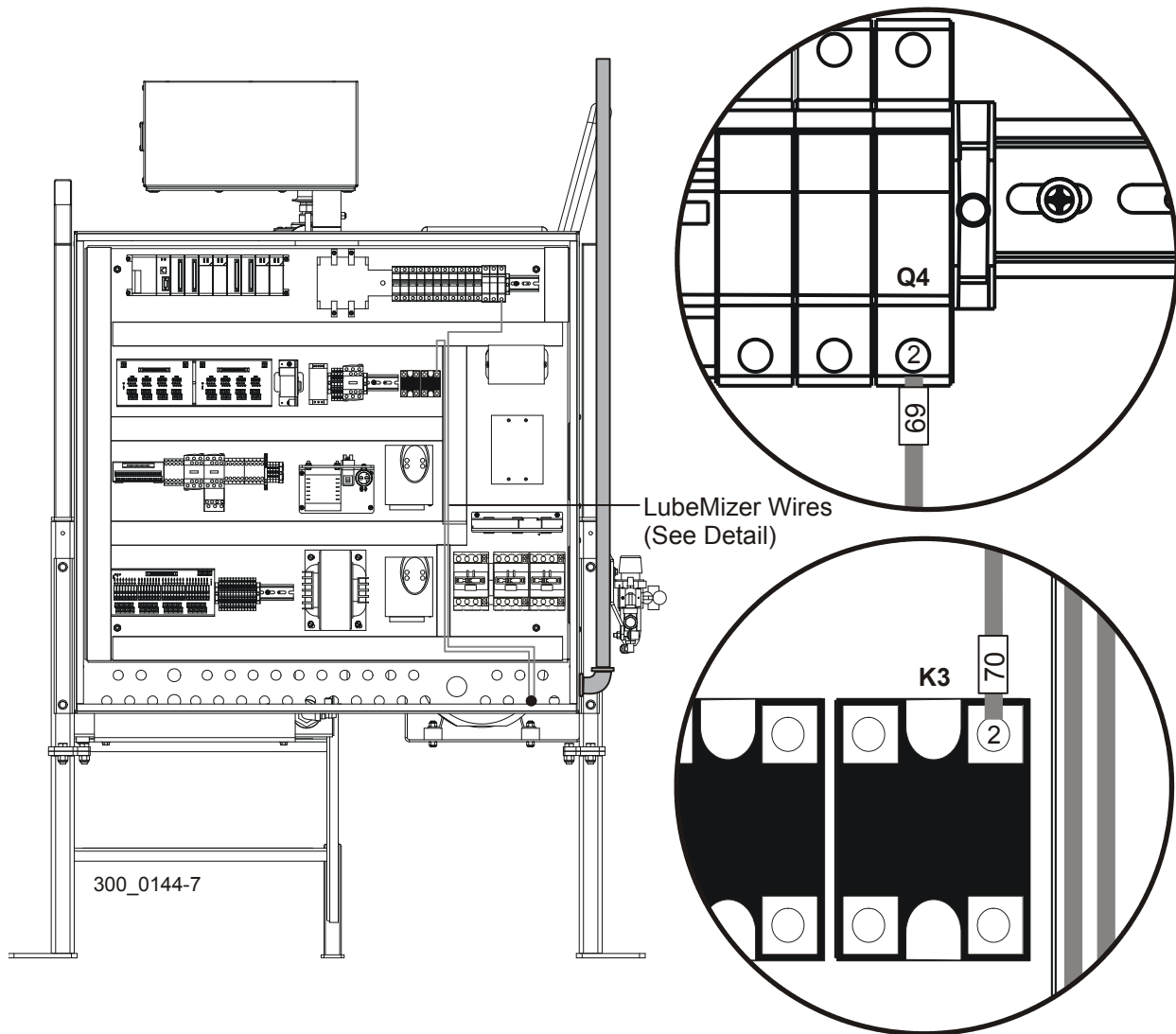
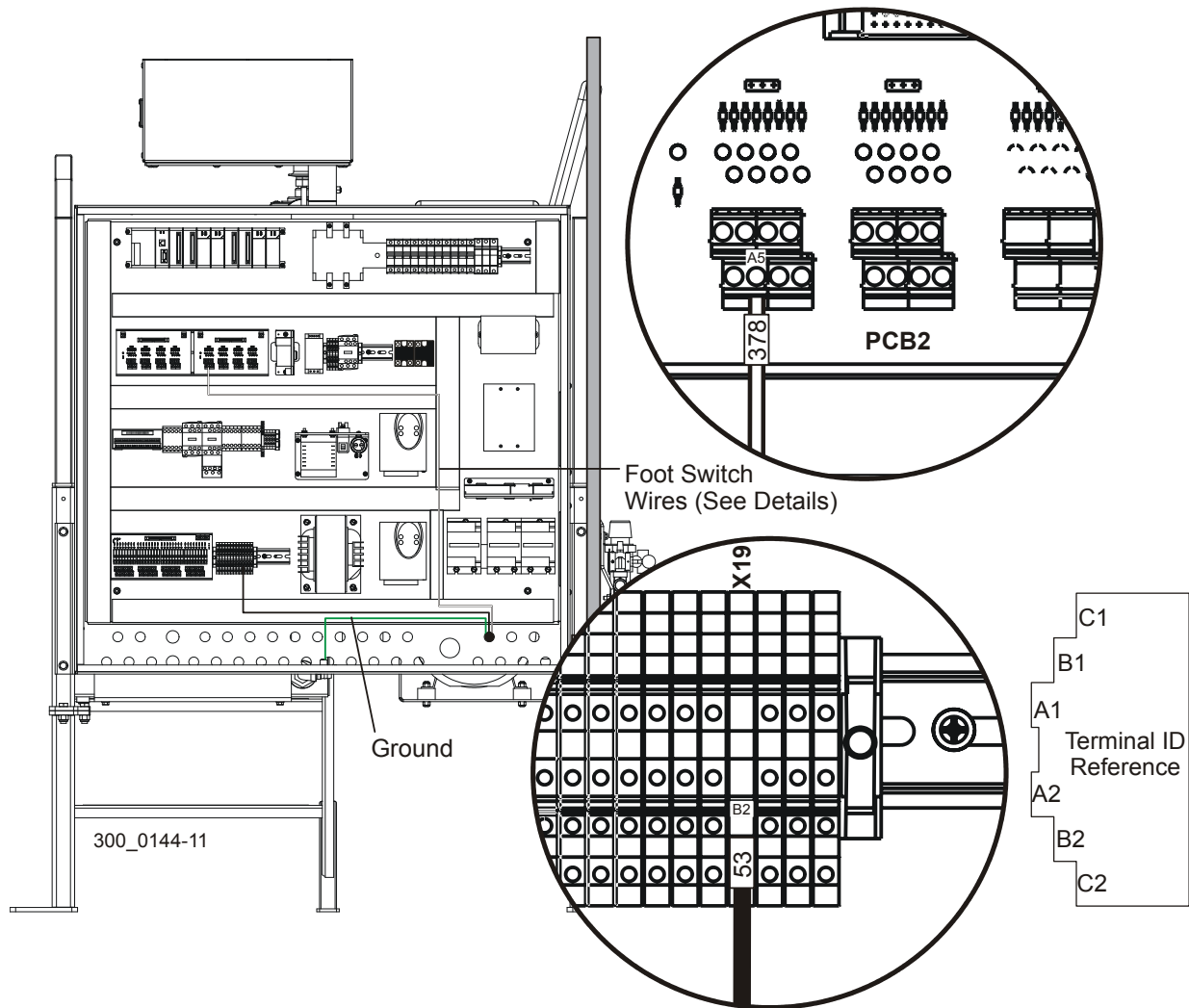


FIG. 3-10

**3.7.7 Debarker Option Foot Switch**

See **Figure 3-11**. Place the foot switch on the floor of the operator station and route the cable to the electrical cabinet. Insert the cable through one of the holes in the bottom of the cabinet and secure with the cable connector provided. Connect the green ground wire to the grounding bar in the bottom of the cabinet. Route black wire #378 to PCB2 module and connect to terminal A5. Route white wire #53 to terminal block X19 and connect to terminal B2.



**FIG. 3-11**

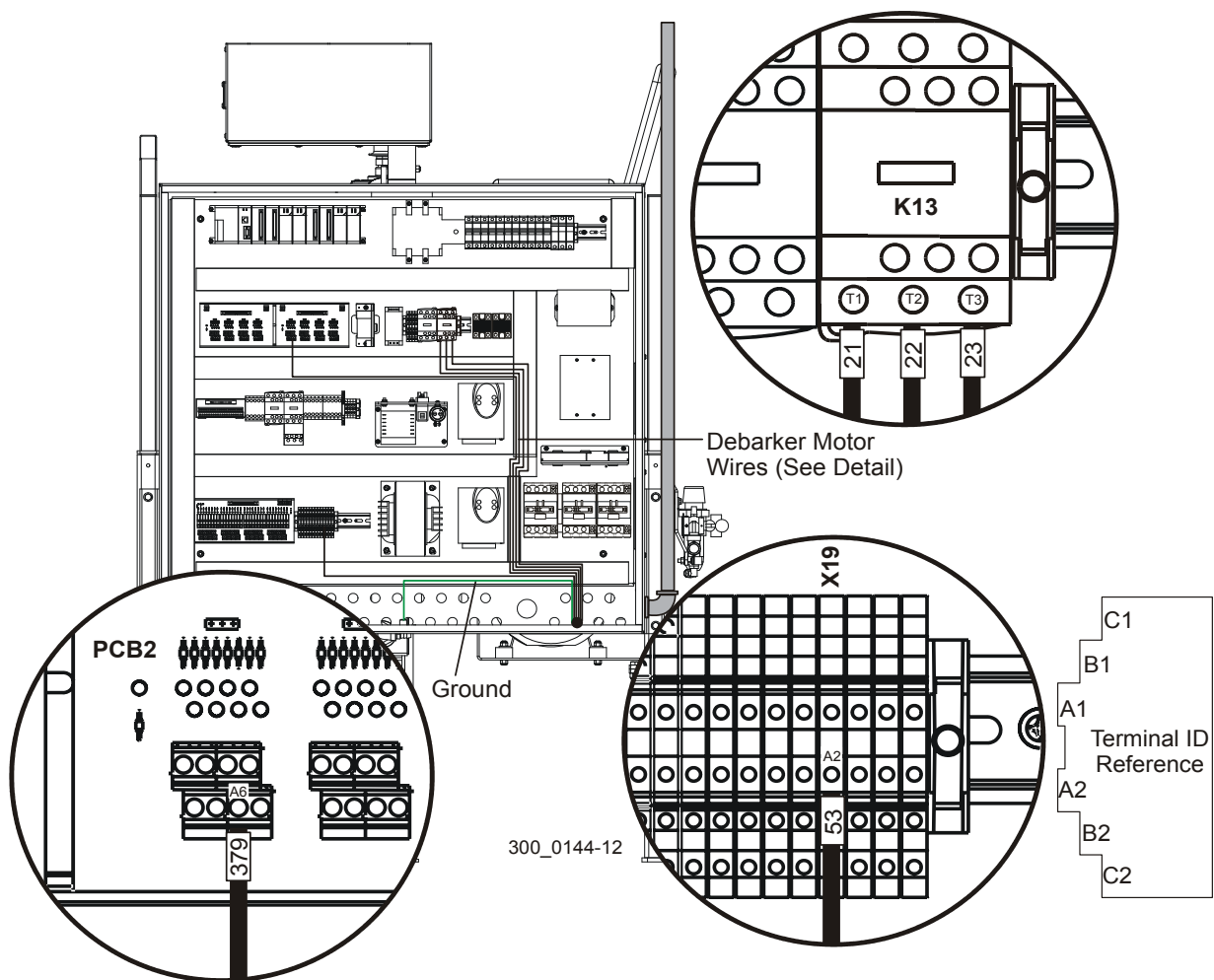
# 3 Setup

## Debarker Option Motor

### 3.7.8 Debarker Option Motor

See **Figure 3-12**. Install the debarker motor harness to the remaining hole at the bottom of the electrical cabinet and secure with the connector provided. Connect the green ground wire to the grounding bar at the bottom of the cabinet. Route wires #21, 22 & 23 to contactor K13. Connect wire #21 to K13 terminal T1, wire #22 to K13 terminal T2 and wire #23 to K13 terminal T3.

Route wire #53 to contactor X19 and connect to terminal A2. Route wire #379 to PCB2 and connect to terminal A6.



**FIG. 3-12**

Install the wireway covers after electrical installation is complete.

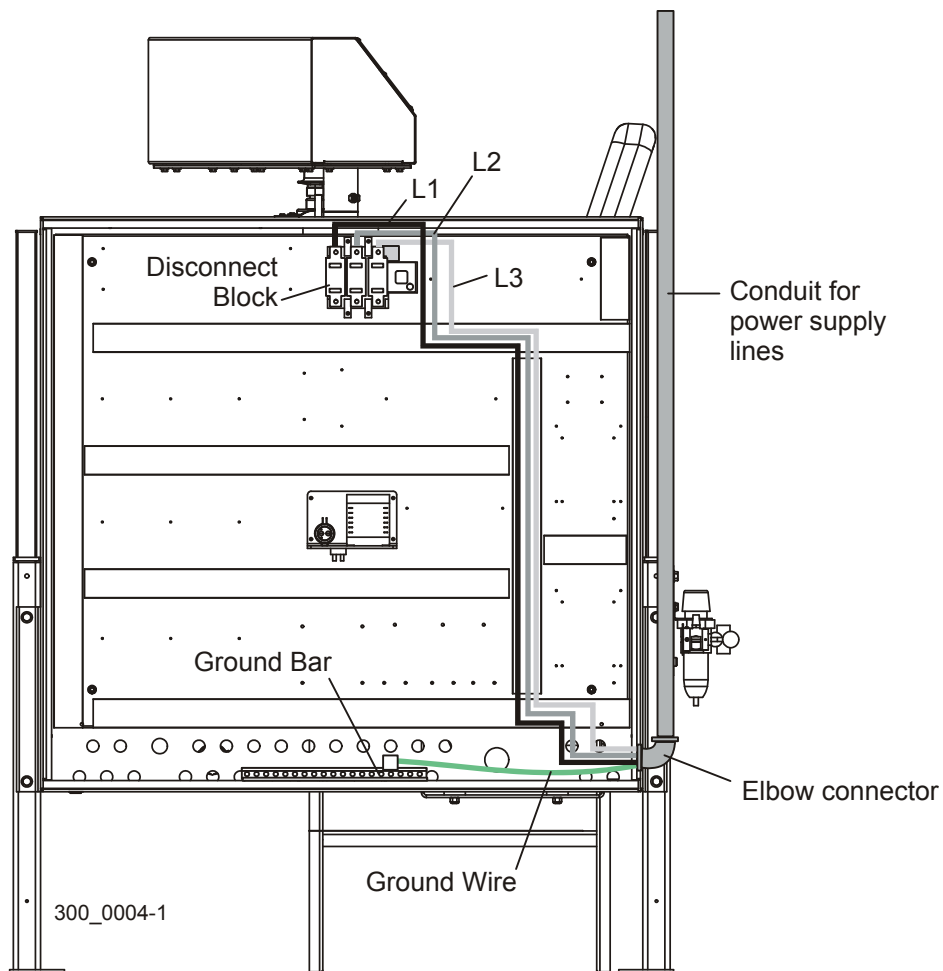
### 3.8 Electrical Installation

#### 3.8.1 LT300 Rev. A9.00 - B2.02



**DANGER!** Make sure all electrical installation, service and/or maintenance work is performed by a qualified electrician and is in accordance with applicable electrical codes.

See **Figure 3-13**. Route the incoming power supply from the disconnect switch to the electrical cabinet. One recommended method is to drop conduit from the ceiling down to the hole in the right side of the cabinet, near the bottom. Install an elbow connector to secure the conduit to the cabinet. Connect the ground wire to the ground bar at the bottom of the cabinet. Remove the wireway covers and route the three power lines through the wireways to the disconnect block at the top of the cabinet.

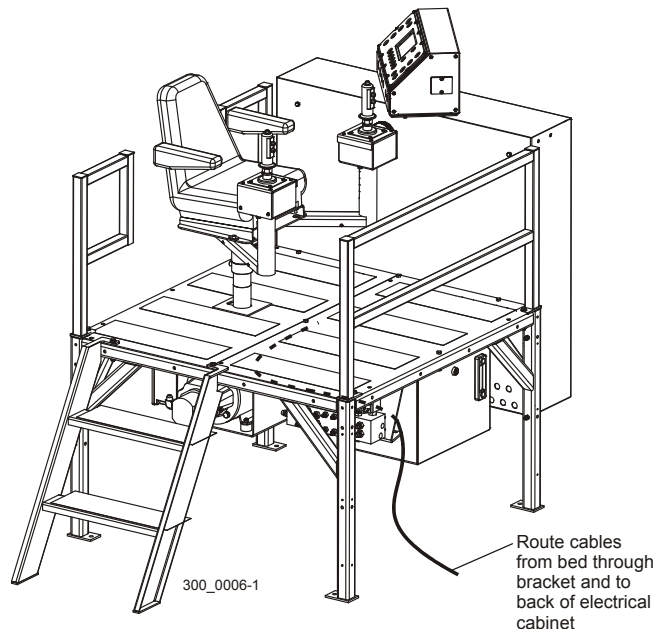


**FIG. 3-13**

### 3 Setup

LT300 Rev. A9.00 - B2.02

See **Figure 3-14**. Several cables connect the sawmill controls to the components in the electrical cabinet. Route the cables under the operator station and tie wrap to the bracket as shown.



**FIG. 3-14**



See Table 3-2. Locate and identify each cable as shown in the table below.

Cable	Function	Box Entry Location <a href="#">See fig. 3-15</a>	Wire Terminal Number	Termination Location (Component ID.Terminal ID)
1	Power Feed <a href="#">See fig. 3-17</a>	P/F	500	U1.T1
			501	U1.T2
			502	U1.T3
			Ground	U1 Ground
2	Up/Down <a href="#">See fig. 3-17</a>	U/D	503	U2.T1
			504	U2.T2
			505	U2.T3
			Ground	U2 Ground
3	Up/Down Brake <a href="#">See fig. 3-18</a>	Brk	506	K5.2
			334	K4.T2
4	Blade Motor <a href="#">See fig. 3-19</a>	25hp Mtr	1	K35.T1
			2	K35.T2
			3	K35.T3
			10	K33.T3
			11	K33.T1
			12	K33.T2
			53	X41.2
			146	X42.2
			Ground	Grounding Bar
5	Transducer <a href="#">See fig. 3-21</a>	Trans	51	X31.B2
			52	X32.C2
			510	X31.A2
			511	X32.A2
7	Lube System <a href="#">See fig. 3-22</a>	Lube	70	K6.2
			69	Q10.2

**TABLE 3-2**

# 3

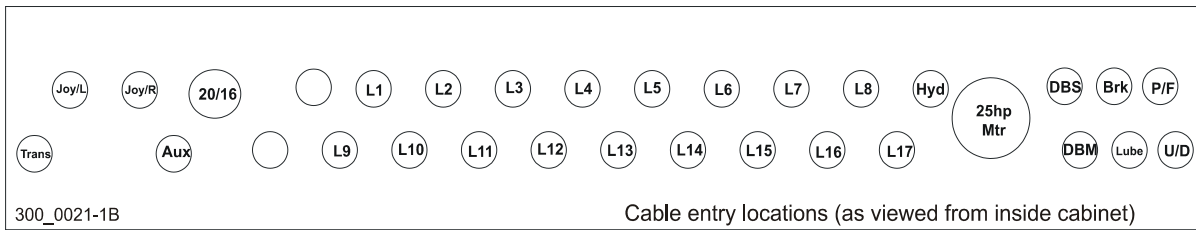
## Setup

LT300 Rev. A9.00 - B2.02

8	Head Box <a href="#">See fig. 3-20</a>	20/16	4 (for Debarker Option)	X29.A2
			26	K31.2
			27	K31.4
			53	X26.A2
			56	X19.B2
			68	X40.A2
			132	X5.A0
			133	X5.A1
			134	X5.A2
			135	K10.11
			139	X5.A7
			140	X5.B0
			141	X5.B1
			149	X5.B7
			200	X14.A0
			201	X14.A1
			9	Debarker Option Foot Switch <a href="#">See fig. 3-23</a>
378	X5.A5			
Ground	Grounding Bar			
10	Debarker Option Motor <a href="#">See fig. 3-24</a>	DBM	21	DB1.T1
			22	DB1.T2
			23	DB1.T3
			53	K1.44
			379	X5.A6
			Ground	Grounding Bar

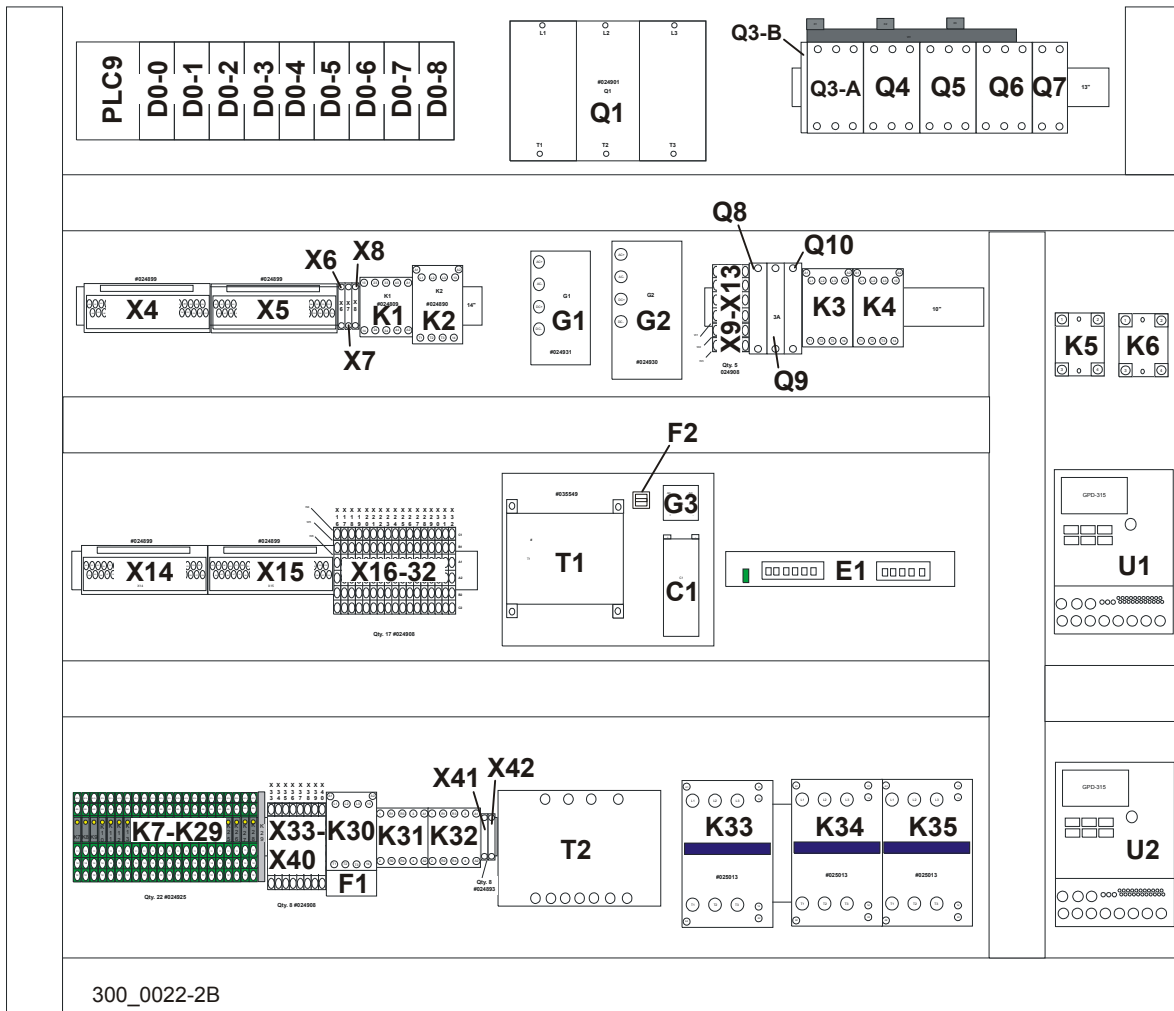
**TABLE 3-2**

**See Figure 3-15.** Insert each cable to the appropriate entry point in the electrical cabinet as show below. Secure each cable to the box with the provided cable connectors.



**FIG. 3-15**

See Figure 3-16. Route each cable to the appropriate components as described in the following instructions.



**FIG. 3-16 REV. A9.00 - B2.02**

### 3.8.2 Power Feed & Up/Down Cables

See **Figure 3-17**. Route the power feed cable through the wireways to the clamp located under A/C drive labeled U1. Fold the metal shielding over the end of the cable and insert into the clamp. Tighten the clamp to secure the cable. Repeat for the up/down cable to the A/C drive labeled U2.

Connect the power feed cable wires to A/C drive labeled U1: Connect wire #500 to terminal #T1, wire #501 to terminal #T2, and wire #502 to terminal #T3. Connect the green ground wire to the ground terminal.

Connect the up/down cable wires to the A/C drive labeled U2: Connect wire #503 to terminal #T1, wire #504 to terminal #T2 and wire #505 to terminal T3. Connect the green ground wire to the ground terminal.

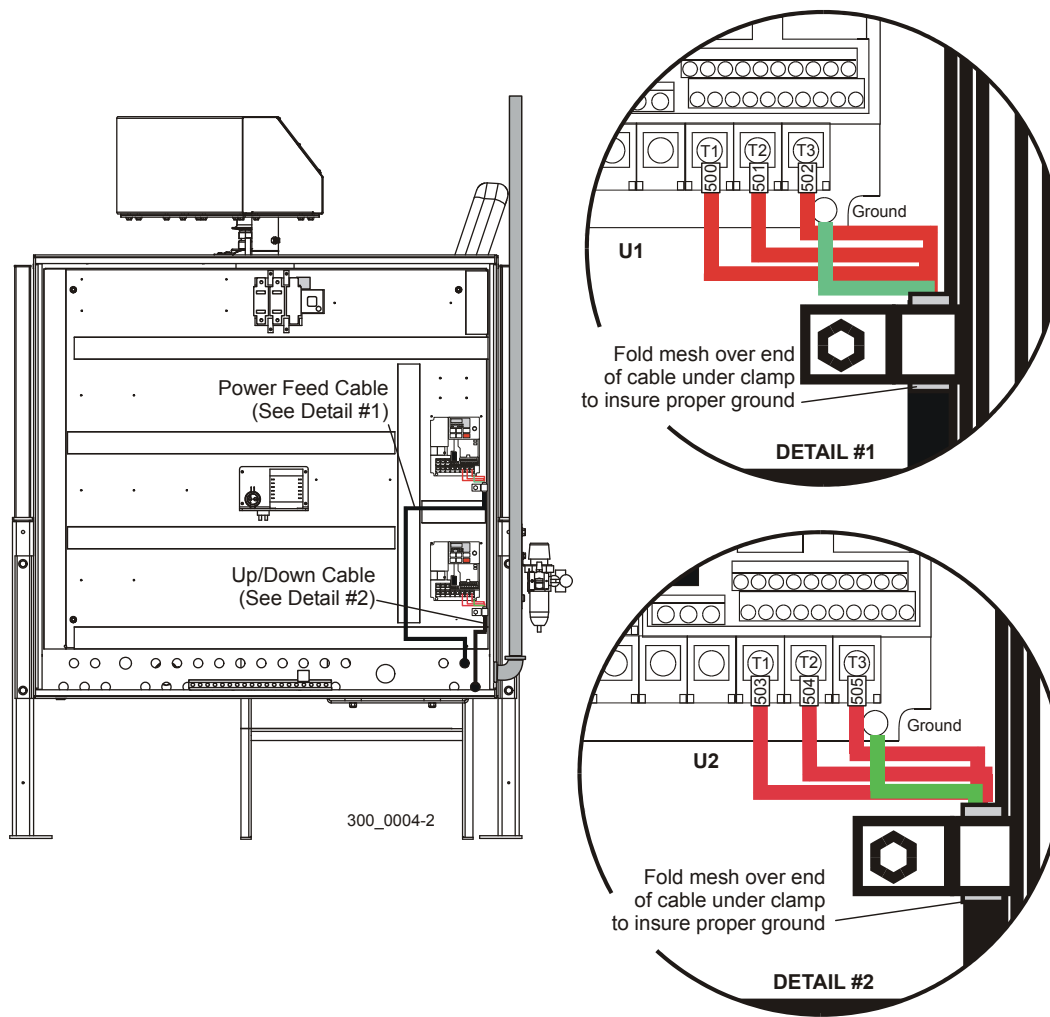
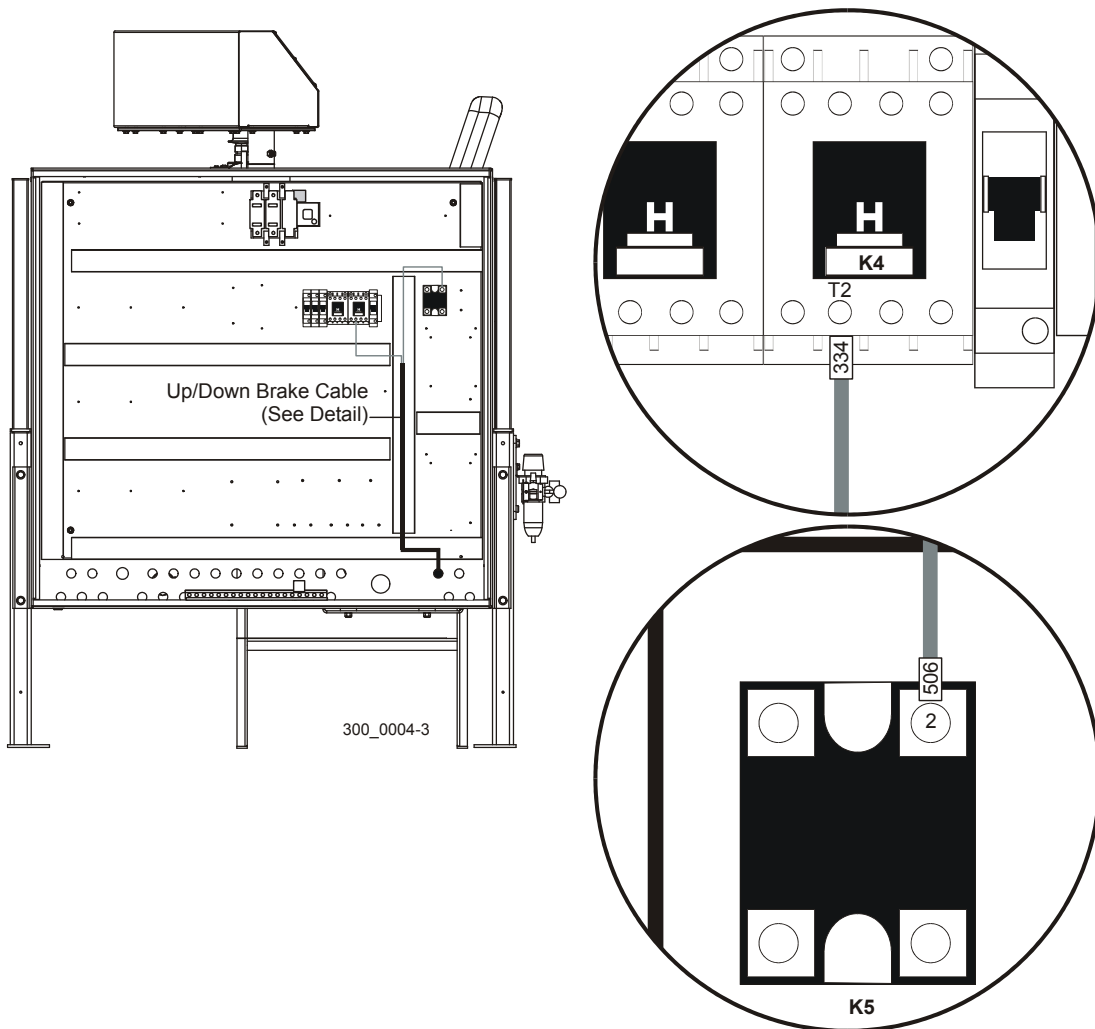


FIG. 3-17

### 3.8.3 Up/Down Brake Cable

See **Figure 3-18**. Route the up/down brake cable through the wireways to the contactor and relay as shown. Connect wire #334 to terminal #T2 of the contactor labeled K4. Connect wire #506 to terminal #2 of the relay labeled K5.



**FIG. 3-18**

# 3 Setup

## Blade Motor Cable

### 3.8.4 Blade Motor Cable

See **Figure 3-19**. Route the motor cable wires with terminals labeled #1, #2 & #3 to the contactor labeled K35. Route wires with terminals labeled #10, 11 & 12 to the contactor labeled K33. Route the green/yellow striped wire to the grounding bar. Route wires with terminals labeled #53 & #146 to the terminal blocks labeled X41 and X42.

At contactor K35, connect wire #1 to terminal T1, wire #2 to terminal T2, and wire #3 to terminal T3. At contactor K33, connect wire #10 to terminal T3, wire #11 to terminal T1, and wire #12 to terminal T2. Connect wire #53 to the bottom terminal of block X41. Connect wire #146 to the bottom terminal of block X42. Connect the ground wire to one of the ports in the grounding bar and secure with a screw.

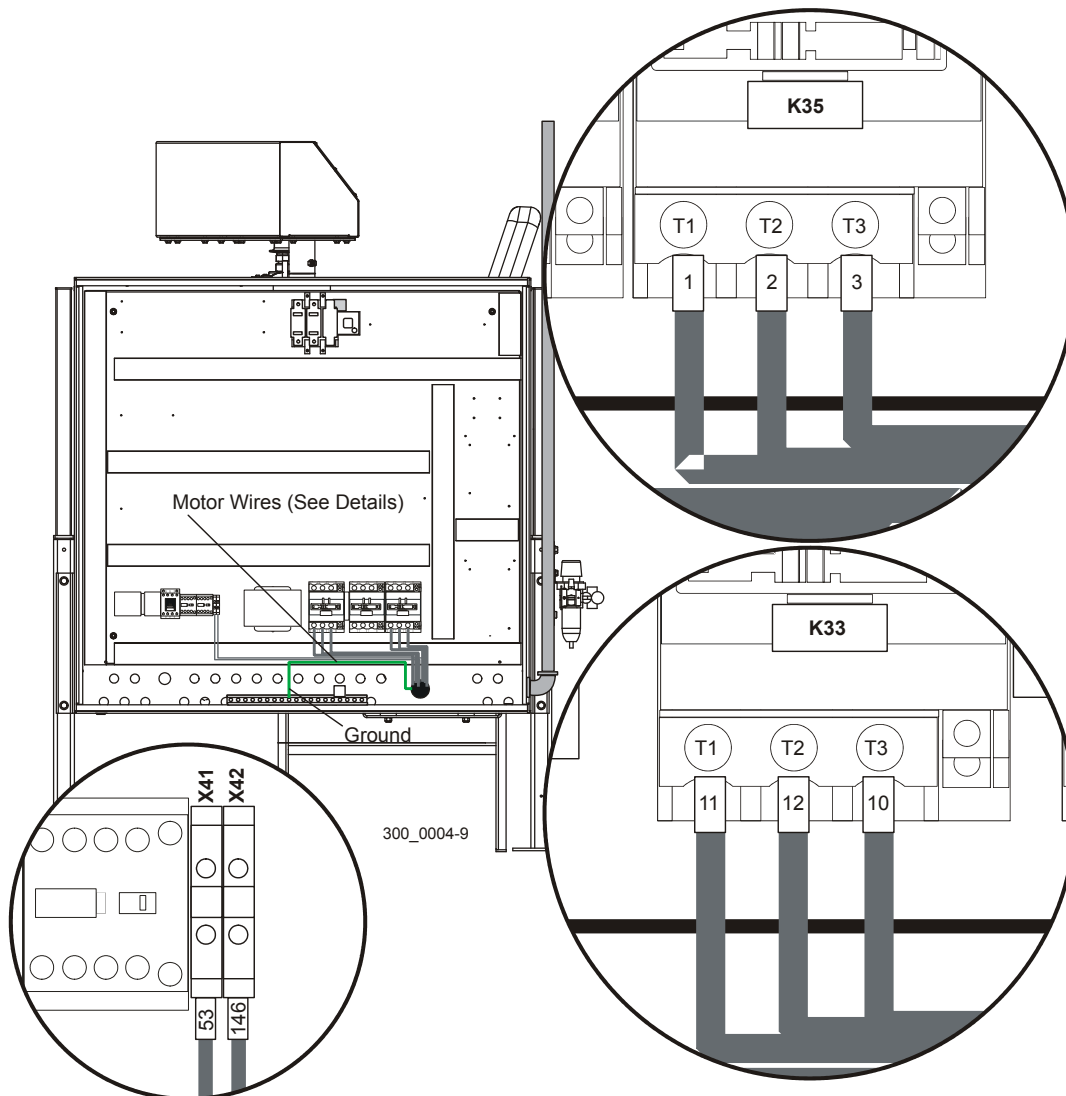


FIG. 3-19

### 3.8.5 Head Box Cable

**See Figure 3-20.** Route the head box cable wires through the wireways to the appropriate components. Route wires with terminals labeled #132, #133, #134, #139, #140, #141 & #149 to the terminal module labeled X5. Route wires with terminals labeled #53 and #56 to the terminal blocks labeled X16-X32. Route the wires with terminals labeled #164, #165 & #166 to the wireway located above the bank of contactors labeled X16-32. These wires are not used. Route the wires with terminals labeled #200 and #201 to the terminal module labeled X14. Route the wire with terminal labeled #68 to the terminal block labeled X40. Route the wires with terminals labeled #135, #253, #254 and #278 to the components labeled K7-K30. Route the wire with terminal labeled #26 and #27 to the relay labeled K31.

At terminal module X5, connect wire #132 to terminal #A0, wire #133 to terminal #A1, wire #134 to terminal #A2, wire #139 to terminal #A7, wire #140 to terminal #B0, wire #141 to terminal #B1 and wire #149 to terminal #B7.

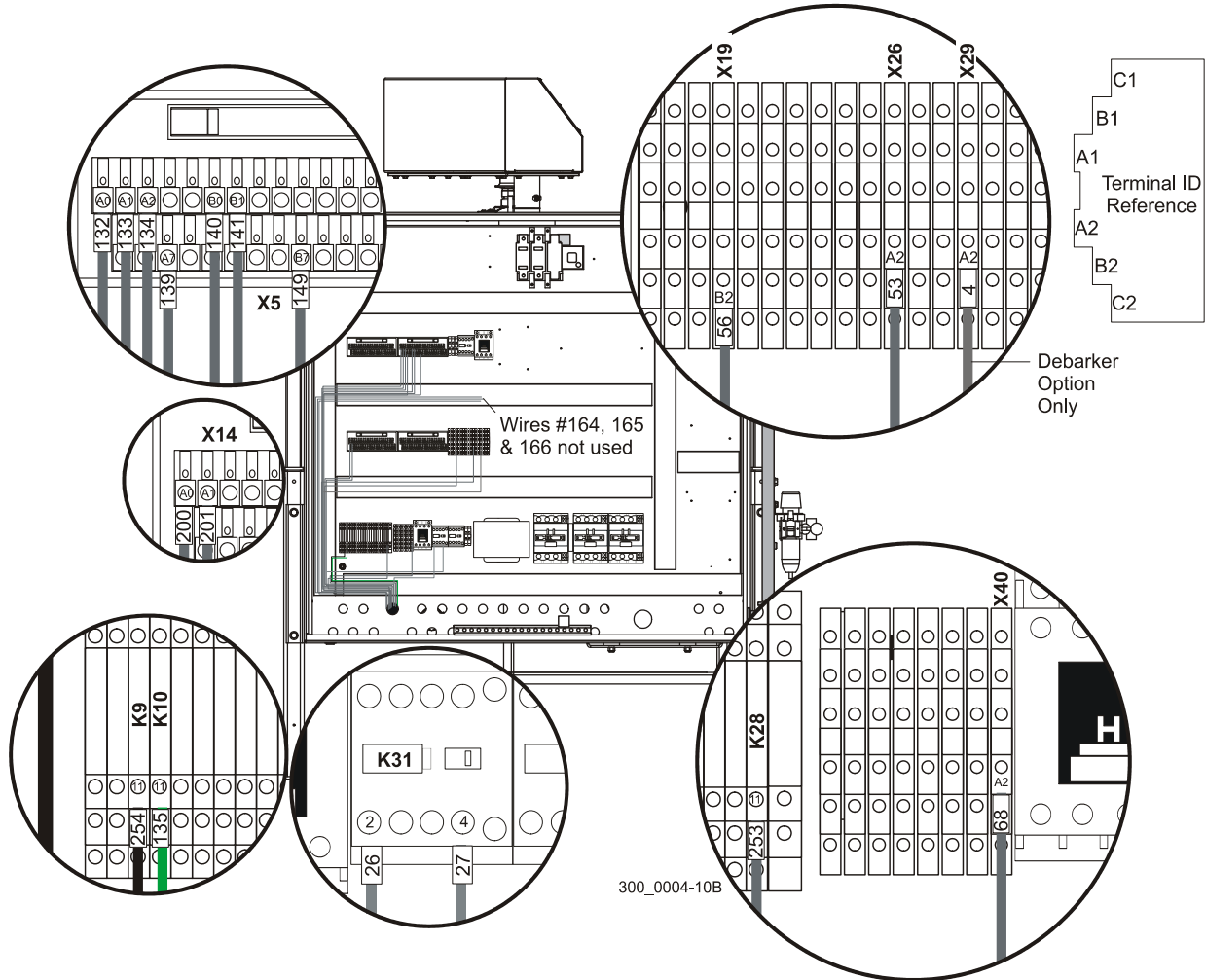
At block X19, connect wire #56 to terminal #B2. At block X26, connect wire #53 to terminal #A2. At relay K28, connect wire #253 to terminal #11. At block #X40, connect wire #68 to terminal #A2.

At connector module X14, connect wire #200 to terminal #A0 and wire #201 to terminal #A1.

At relay K9, connect wire #254 to terminal #11. At relay K10, connect wire #135 to terminal #11. At relay K31, connect wire #26 to terminal #2 and wire #27 to terminal #4 (leave existing wires connected).

### 3 Setup Head Box Cable

**Debarcker Option Only:** Route wire #4 to terminal block X29 and connect to terminal A2.



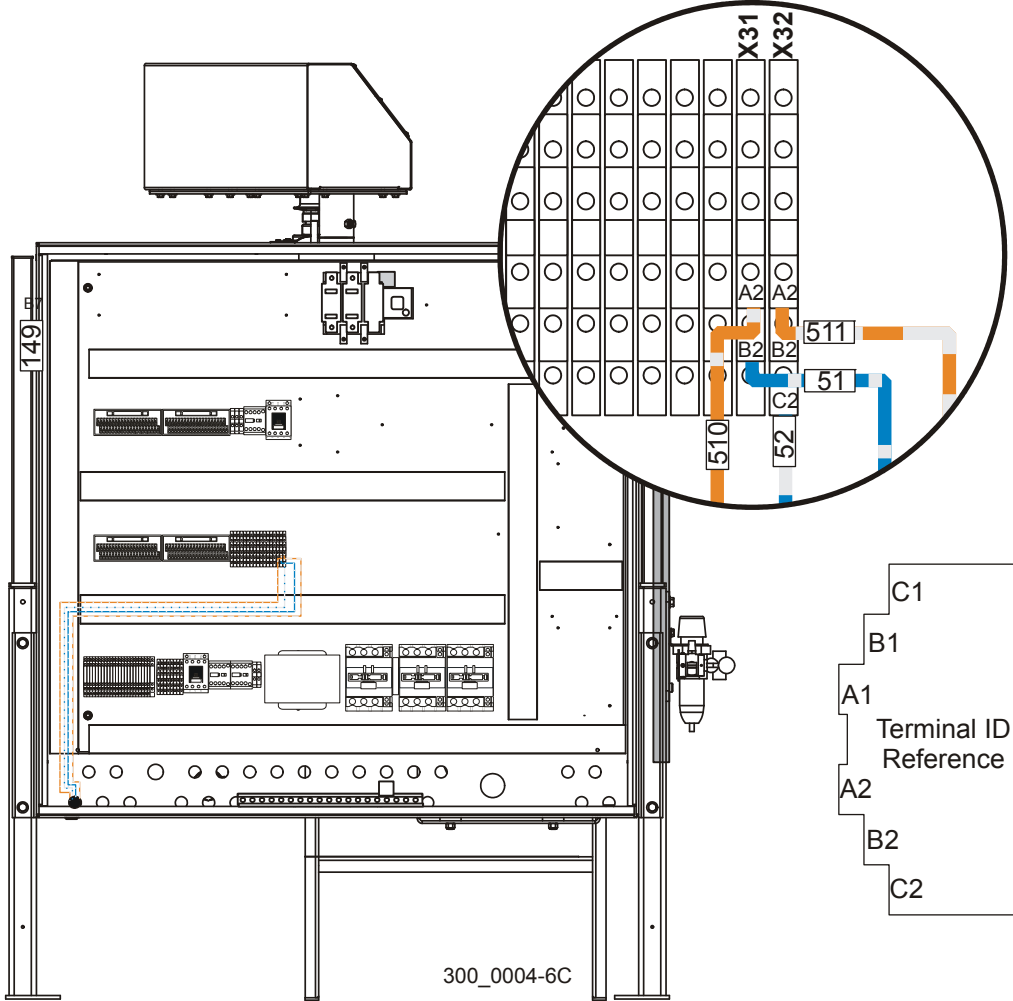
**FIG. 3-20**



**3.8.6 Transducer Cable**

See **Figure 3-21**. Route the transducer cable through the wireways to the terminal blocks labeled X31 and X32.

At block X31, connect wire with terminal labeled #510 to terminal #A2 and wire #51 to terminal #B2. At block X32, connect the wire with terminal labeled #52 to terminal #C2 and wire #511 to terminal #A2.



**FIG. 3-21**

# 3 Setup

## Lube System Cable

### 3.8.7 Lube System Cable

See **Figure 3-22**. Route the lube system cable wires through the wireways to the relay labeled K6 and the breaker labeled Q10.

Connect wire #70 to relay K6, terminal #2. Connect wire #69 to breaker Q10, terminal #2.

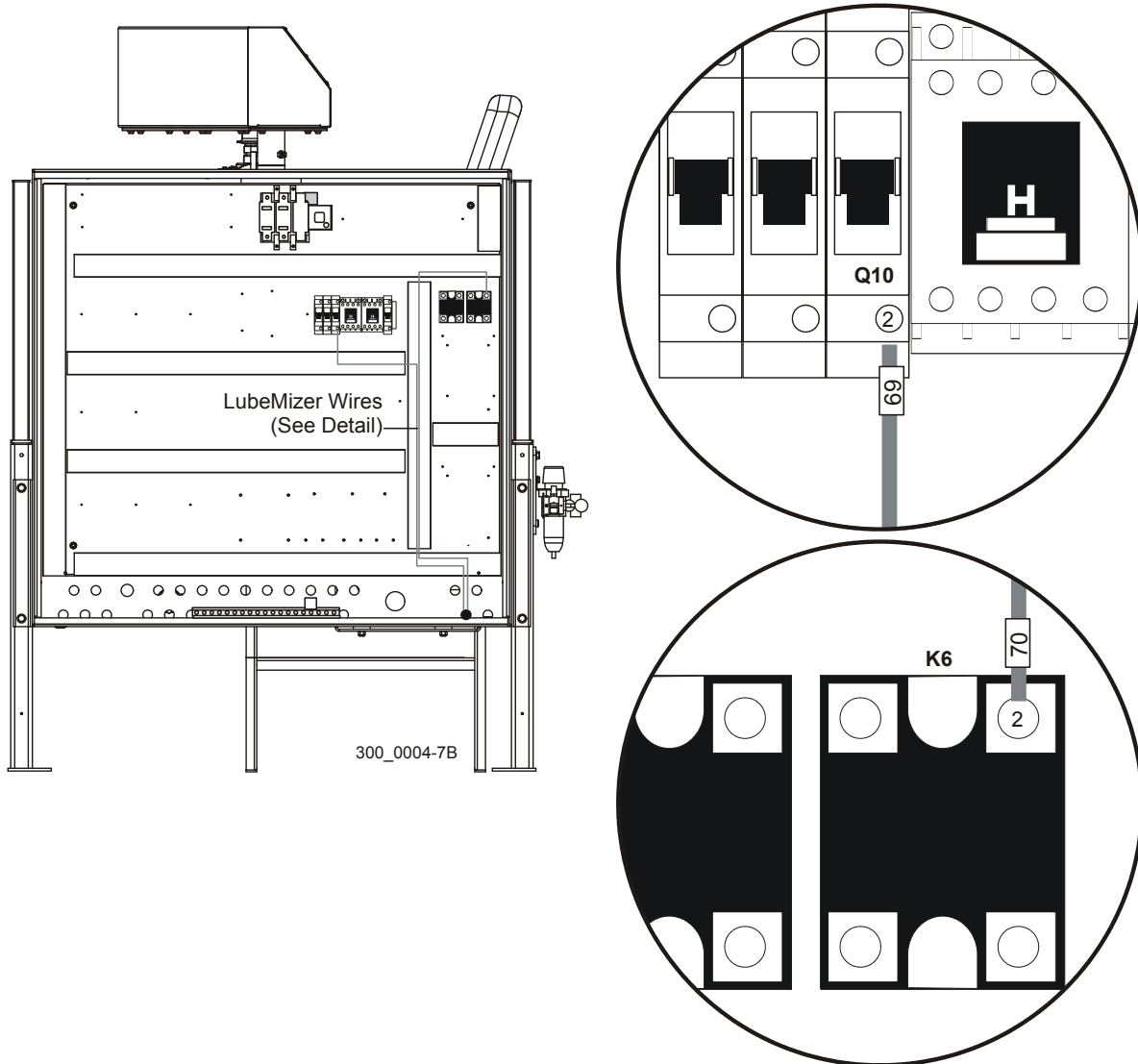
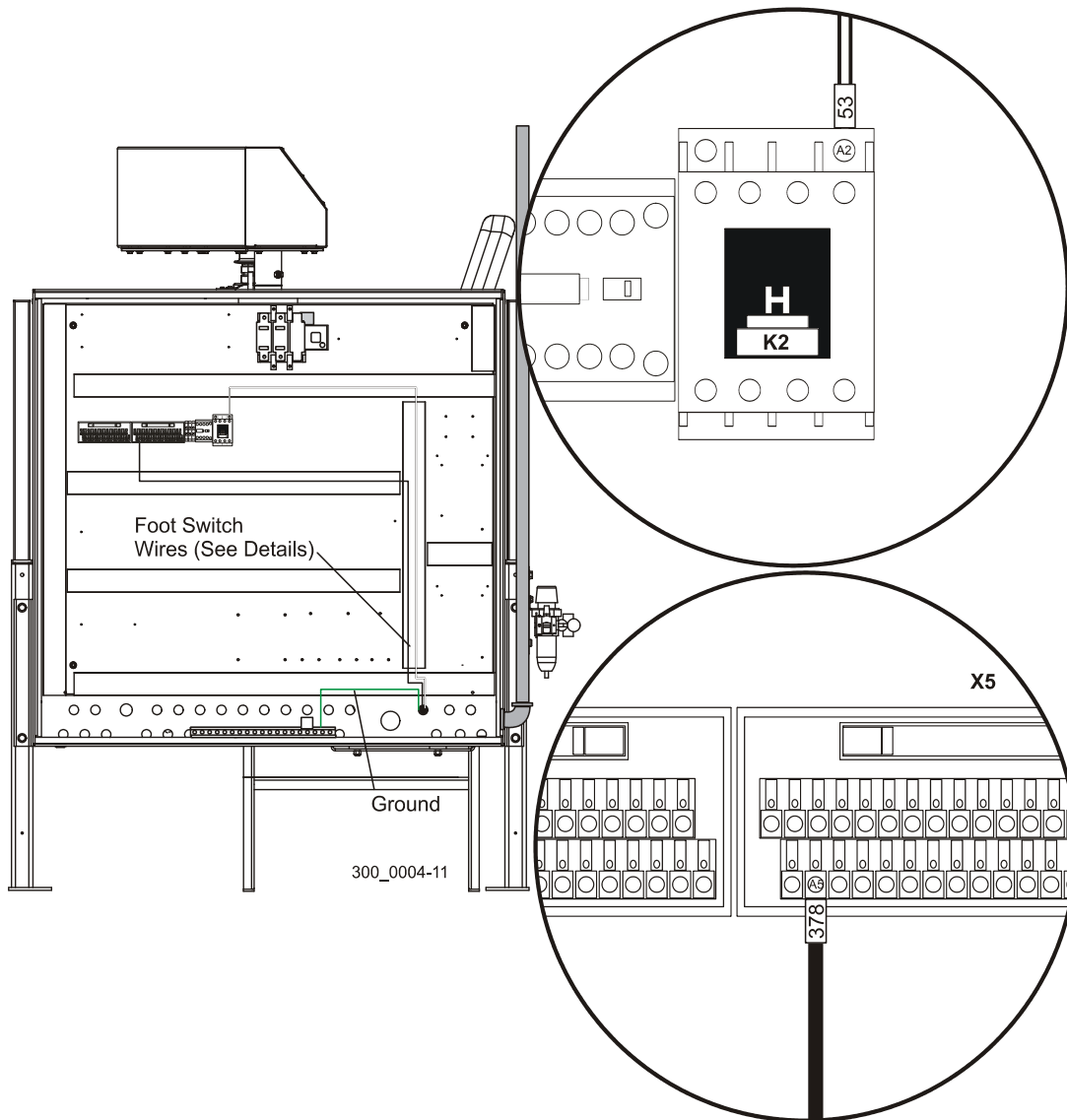


FIG. 3-22

**3.8.8 Debarker Option Foot Switch**

See **Figure 3-23**. Place the foot switch on the floor of the operator station and route the cable to the electrical cabinet. Insert the cable through one of the holes in the bottom of the cabinet and secure with the cable connector provided. Connect the green ground wire to the grounding bar in the bottom of the cabinet. Route black wire #378 to PLC module X5 and connect to terminal A5. Route white wire #53 to contactor K2 and connect to terminal A2.



**FIG. 3-23**

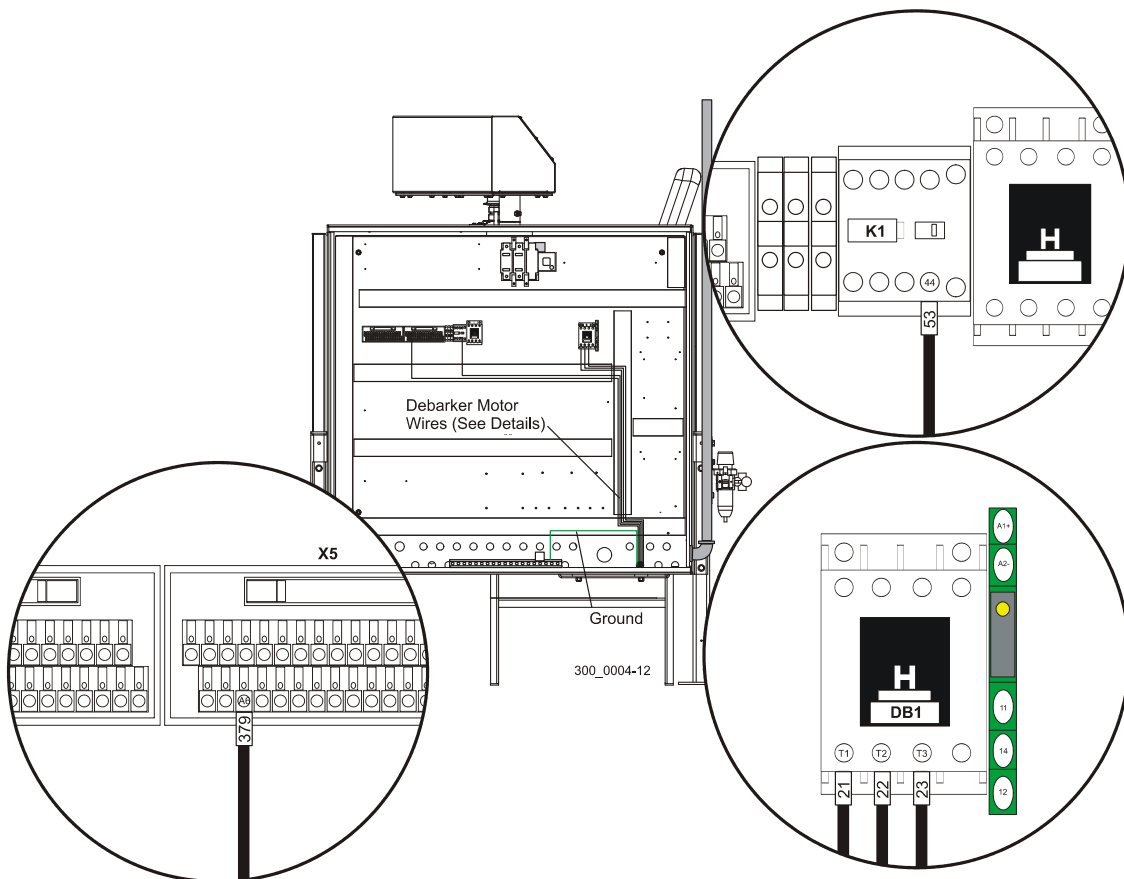
# 3 Setup

## Debarker Option Motor

### 3.8.9 Debarker Option Motor

See **Figure 3-24**. Install the debarker motor harness to the remaining hole at the bottom of the electrical cabinet and secure with the connector provided. Connect the green ground wire to the grounding bar at the bottom of the cabinet. Route wires #21, 22 & 23 to contactor DB1. Connect wire #21 to DB1 terminal T1, wire #22 to DB1 terminal T2 and wire #23 to DB1 terminal T3.

Route wire #53 to contactor K1 and connect to terminal 44. Route wire #379 to PLC module X5 and connect to terminal A6.



**FIG. 3-24**

Install the wireway covers after electrical installation is complete.

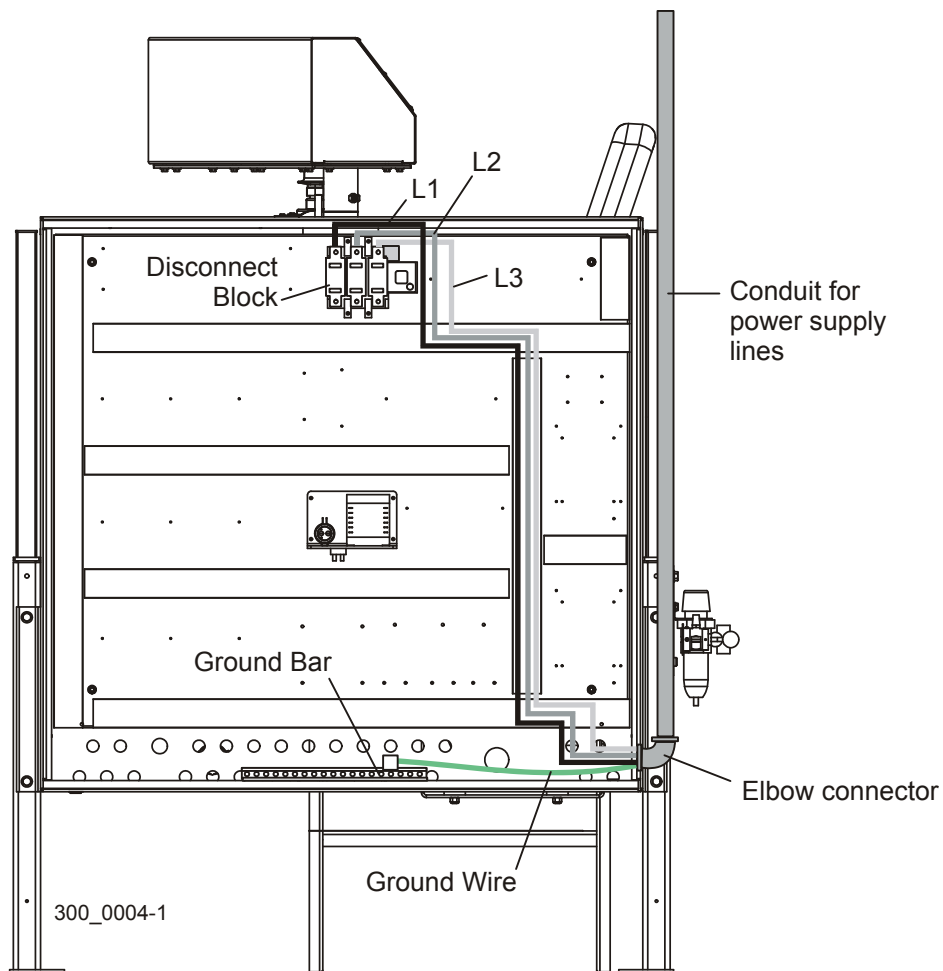
### 3.9 Electrical Installation

#### 3.9.1 LT300 Rev. A1.00 - A8.00



**DANGER!** Make sure all electrical installation, service and/or maintenance work is performed by a qualified electrician and is in accordance with applicable electrical codes.

See **Figure 3-25**. Route the incoming power supply from the disconnect switch to the electrical cabinet. One recommended method is to drop conduit from the ceiling down to the hole in the right side of the cabinet, near the bottom. Install an elbow connector to secure the conduit to the cabinet. Connect the ground wire to the ground bar at the bottom of the cabinet. Remove the wireway covers and route the three power lines through the wireways to the disconnect block at the top of the cabinet.

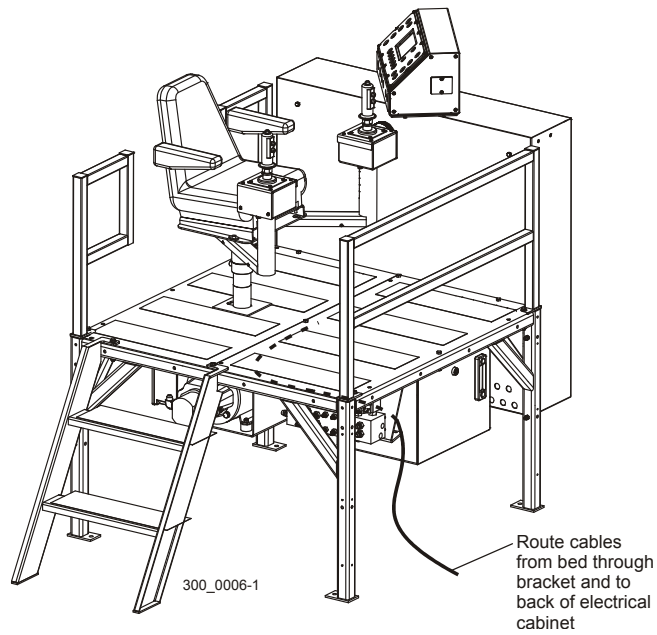


**FIG. 3-25**

### 3 Setup

LT300 Rev. A1.00 - A8.00

See **Figure 3-26**. Several cables connect the sawmill controls to the components in the electrical cabinet. Route the cables under the operator station and tie wrap to the bracket as shown.



**FIG. 3-26**

See Table 3-3. Locate and identify each cable as shown in the table below.

Cable	Function	Box Entry Location <a href="#">See fig. 3-27A</a> or <a href="#">See fig. 3-27B</a>	Wire Terminal Number	Termination Location (Component ID.Terminal ID)
1	Power Feed <a href="#">See fig. 3-29</a>	P/F	500	U1.T1
			501	U1.T2
			502	U1.T3
			Ground	U1 Ground
2	Up/Down <a href="#">See fig. 3-29</a>	U/D	503	U2.T1
			504	U2.T2
			505	U2.T3
			Ground	U2 Ground
3	Up/Down Brake <a href="#">See fig. 3-30</a>	Brk	506	K5.2
			334	K4.T2
4	Blade Motor <a href="#">See fig. 3-31</a>	25hp Mtr	1	K36.T1
			2	K36.T2
			3	K36.T3
			10	K34.T3
			11	K34.T1
			12	K34.T2
			53	X41.2
			146	X42.2
			Ground	Grounding Bar
5	Transducer <a href="#">See fig. 3-33</a>	Trans	51	X32.B2
			52	X32.C2
			510	X31.A2
			511	X32.A2
6	Bed Sensors <a href="#">See fig. 3-35</a>	Bed Rev. A1.00 - A5.01 Only	53	X28.A1
			56	X20.B2
			136	X5.A4
			137	X5.A5
			138	X5.A6
			No terminal	Not Used
No terminal	Not Used			
7	Lube System <a href="#">See fig. 3-34</a>	Lube	N/A	K6.2
			N/A	Q10.2

**TABLE 3-3**

# 3 Setup

LT300 Rev. A1.00 - A8.00

8	Head Box <a href="#">See fig. 3-32</a>	20/16	26	K32.2
			27	K32.4
			53	X26.A2
			56	X19.B2
			68	X40.A2
			132	X5.A0
			133	X5.A1
			134	X5.A2
			135	K10.11
			139	X5.A7
			140	X5.B0
			141	X5.B1
			164	Not Used
			165	Not Used
			166	Not Used
			149	X5.B7
			200	X14.A0
			201	X14.A1
			253	K29.11
			254	K9.11
278	K11.11			

TABLE 3-3

See Figure 3-27. Insert each cable to the appropriate entry point in the electrical cabinet as show below. Secure each cable to the box with the provided cable connectors.

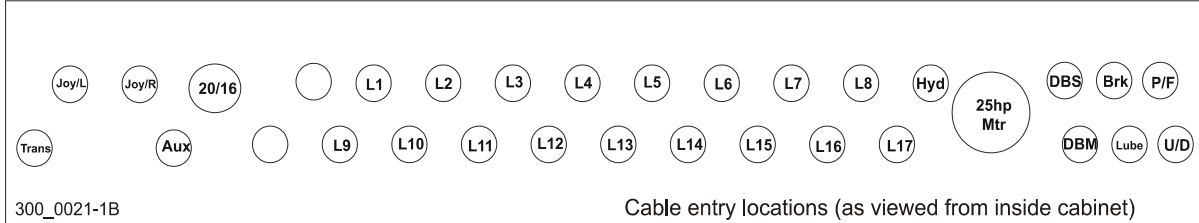


FIG. 3-27A REV. A6.00+

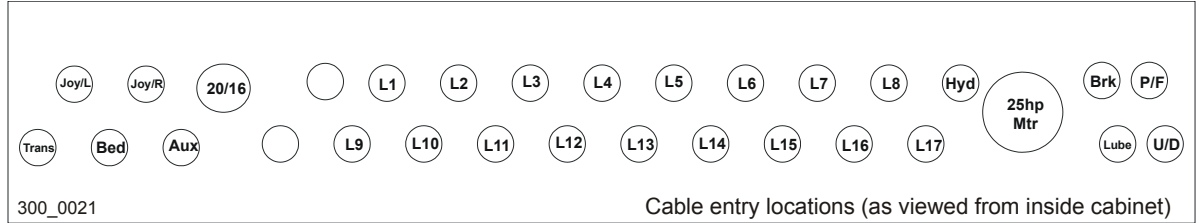
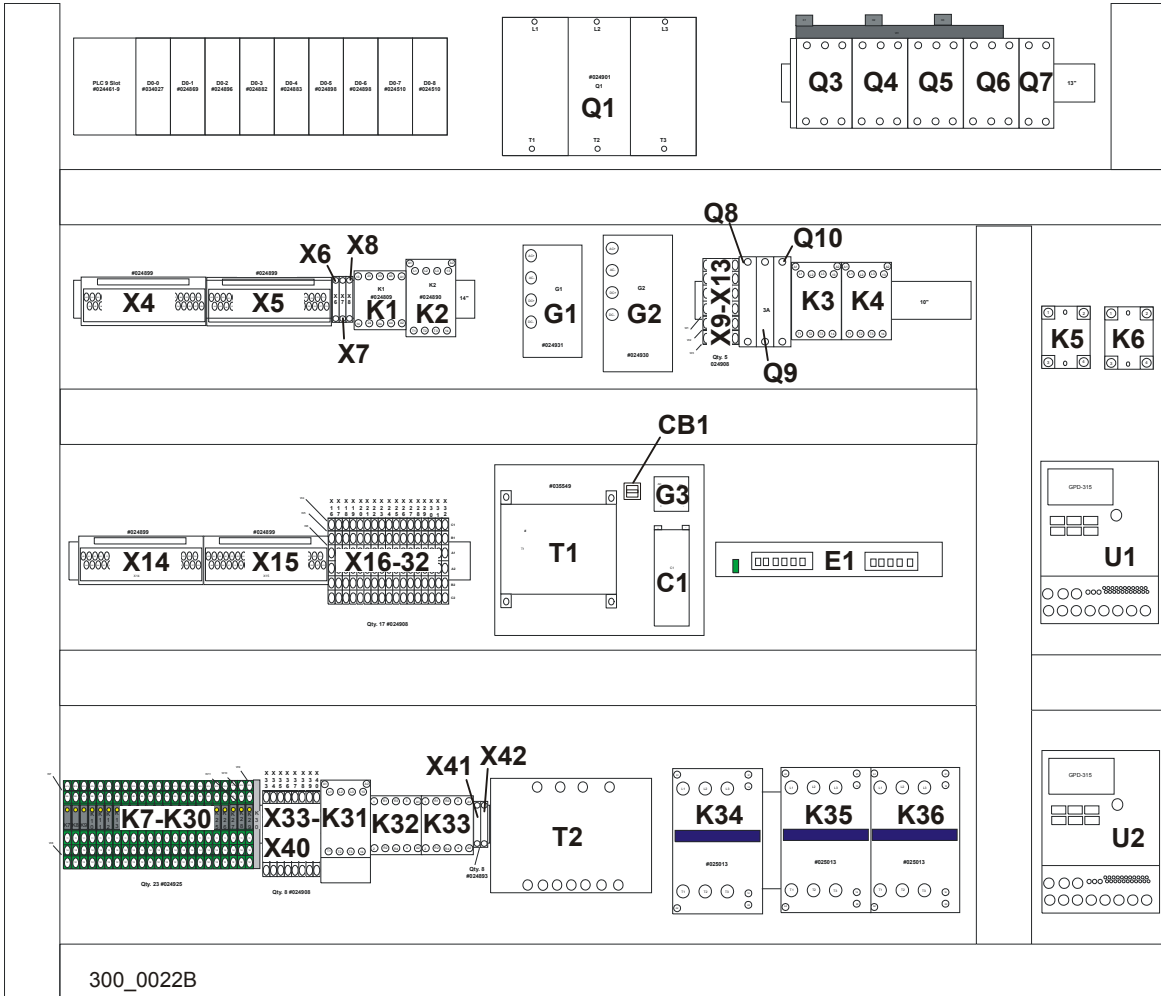


FIG. 3-27B REV. A1.00 - A1.05 (WITH BED SENSOR CABLE)



See **Figure 3-28**. Route each cable to the appropriate components as described in the following instructions.



**FIG. 3-28**

# 3 Setup

## Power Feed & Up/Down Cables

### 3.9.2 Power Feed & Up/Down Cables

See **Figure 3-29**. Route the power feed cable through the wireways to the clamp located under A/C drive labeled U1. Fold the metal shielding over the end of the cable and insert into the clamp. Tighten the clamp to secure the cable. Repeat for the up/down cable to the A/C drive labeled U2.

Connect the power feed cable wires to A/C drive labeled U1: Connect wire #500 to terminal #T1, wire #501 to terminal #T2, and wire #502 to terminal #T3. Connect the green ground wire to the ground terminal.

Connect the up/down cable wires to the A/C drive labeled U2: Connect wire #503 to terminal #T1, wire #504 to terminal #T2 and wire #505 to terminal T3. Connect the green ground wire to the ground terminal.

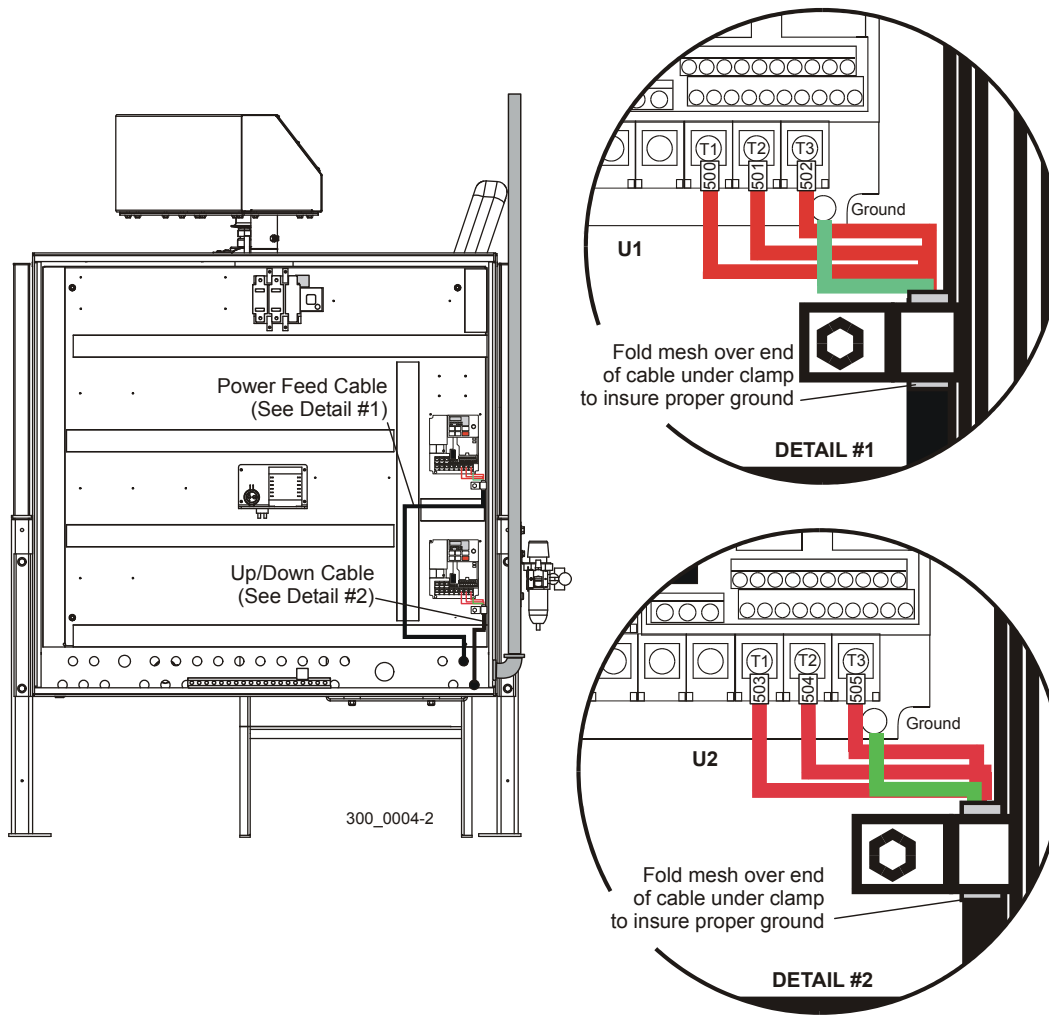
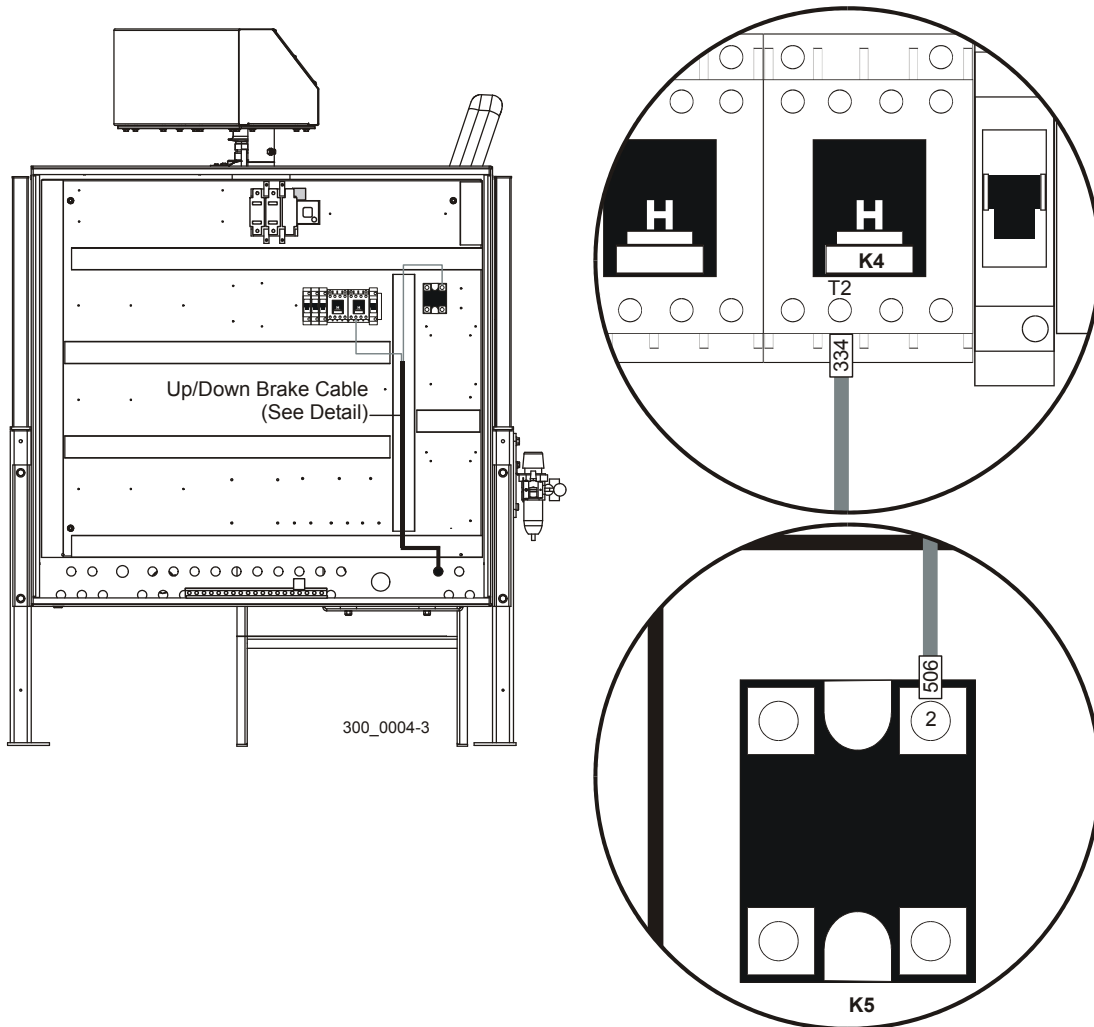


FIG. 3-29

### 3.9.3 Up/Down Brake Cable

See **Figure 3-30**. Route the up/down brake cable through the wireways to the contactor and relay as shown. Connect wire #334 to terminal #T2 of the contactor labeled K4. Connect wire #506 to terminal #2 of the relay labeled K5.



**FIG. 3-30**

# 3 Setup

## Blade Motor Cable

### 3.9.4 Blade Motor Cable

See **Figure 3-31**. Route the motor cable wires with terminals labeled #1, #2 & #3 to the contactor labeled K36. Route wires with terminals labeled #10, 11 & 12 to the contactor labeled K34. Route the green/yellow striped wire to the grounding bar. Route wires with terminals labeled #53 & #146 to the terminal blocks labeled X41 and X42.

At contactor K36, connect wire #1 to terminal T1, wire #2 to terminal T2, and wire #3 to terminal T3. At contactor K34, connect wire #10 to terminal T3, wire #11 to terminal T1, and wire #12 to terminal T2. Connect wire #53 to the bottom terminal of block X41. Connect wire #146 to the bottom terminal of block X42. Connect the ground wire to one of the ports in the grounding bar and secure with a screw.

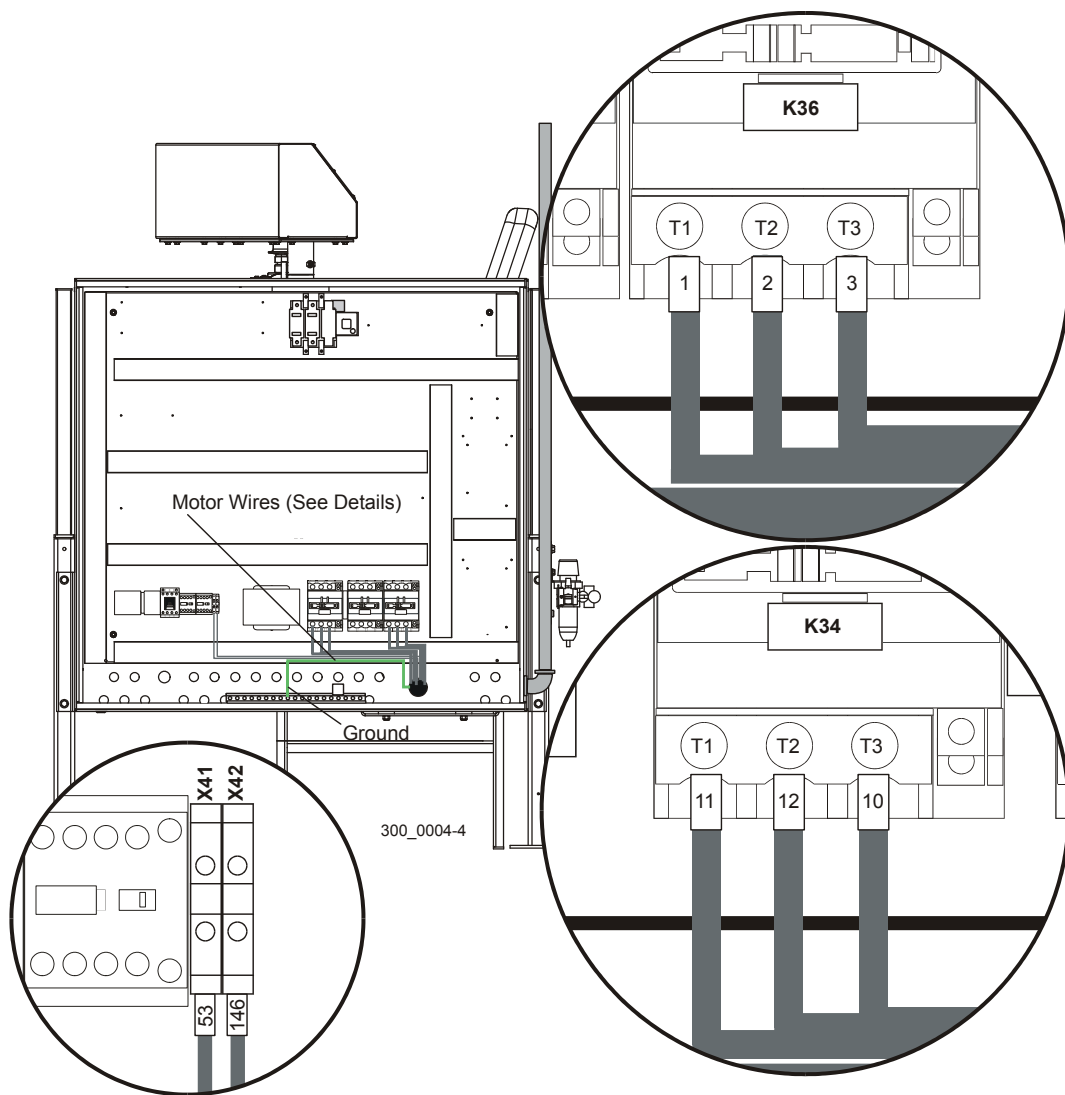


FIG. 3-31

### 3.9.5 Head Box Cable

**See Figure 3-32.** Route the head box cable wires through the wireways to the appropriate components. Route wires with terminals labeled #132, #133, #134, #139, #140, #141 & #149 to the terminal module labeled X5. Route wires with terminals labeled #53 and #56 to the terminal blocks labeled X16-X32. Route the wires with terminals labeled #164, #165 & #166 to the wireway located above the bank of contactors labeled X16-32. These wires are not used. Route the wires with terminals labeled #200 and #201 to the terminal module labeled X14. Route the wire with terminal labeled #68 to the terminal block labeled X40. Route the wires with terminals labeled #135, #253, #254 and #278 to the relays labeled K7-K30. Route the wire with terminal labeled #26 and #27 to the relay labeled K32.

At terminal module X5, connect wire #132 to terminal #A0, wire #133 to terminal #A1, wire #134 to terminal #A2, wire #139 to terminal #A7 (Rev. A3.00+ Only), wire #140 to terminal #B0, wire #141 to terminal #B1 and wire #149 to terminal #B7.

At block X19, connect wire #56 to terminal #B2. At block X26, connect wire #53 to terminal #A2. At relay K29, connect wire #253 to terminal #11. At block #X40, connect wire #68 to terminal #A2.

At connector module X14, connect wire #200 to terminal #A0 and wire #201 to terminal #A1.

At relay K9, connect wire #254 to terminal #11. At relay K10, connect wire #135 to terminal #11. At contactor K11, connect wire #278 to terminal #11. At relay K32, connect wire

### 3 Setup Head Box Cable

#26 to terminal #2 and wire #27 to terminal #4 (leave existing wires connected).

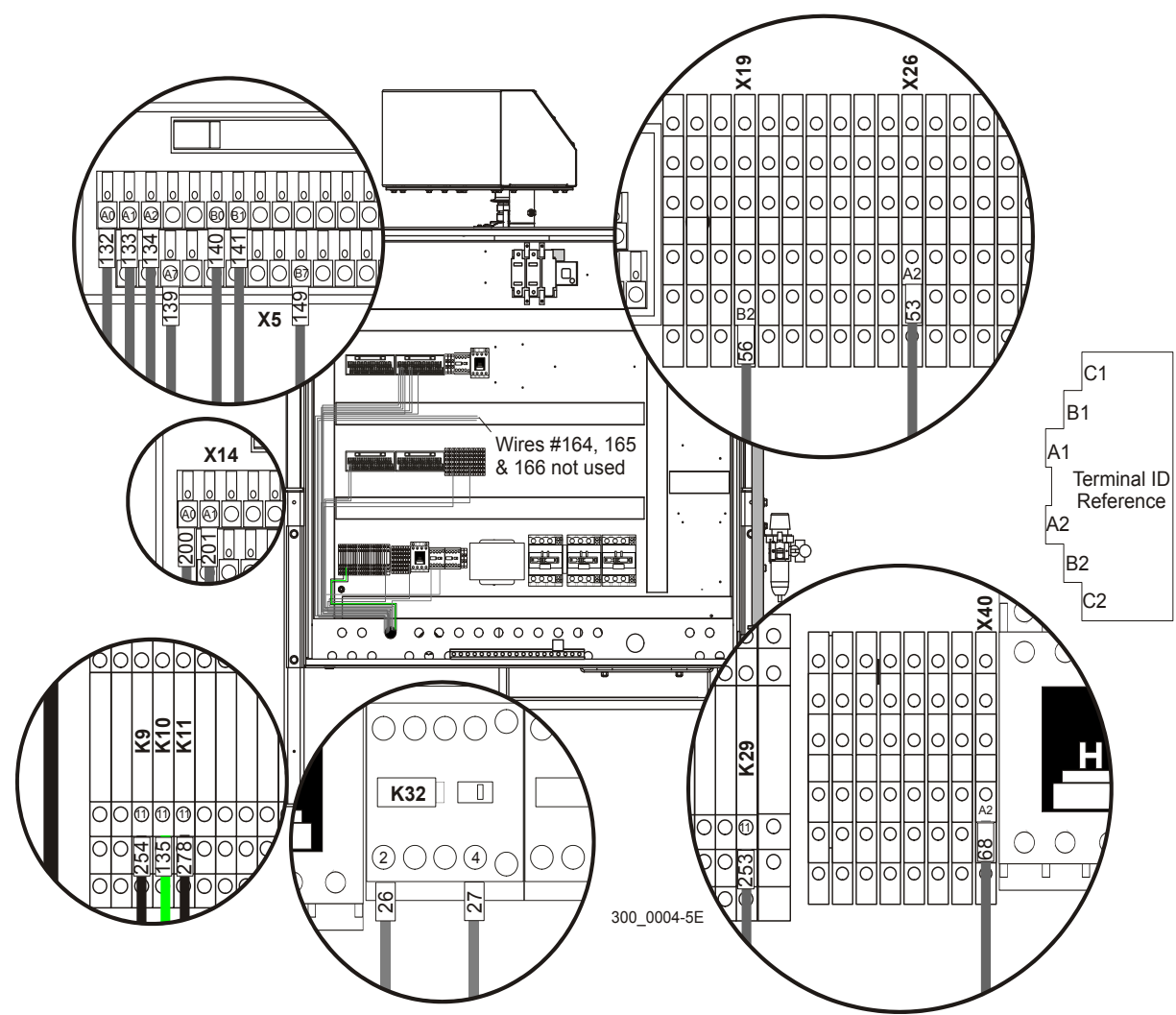
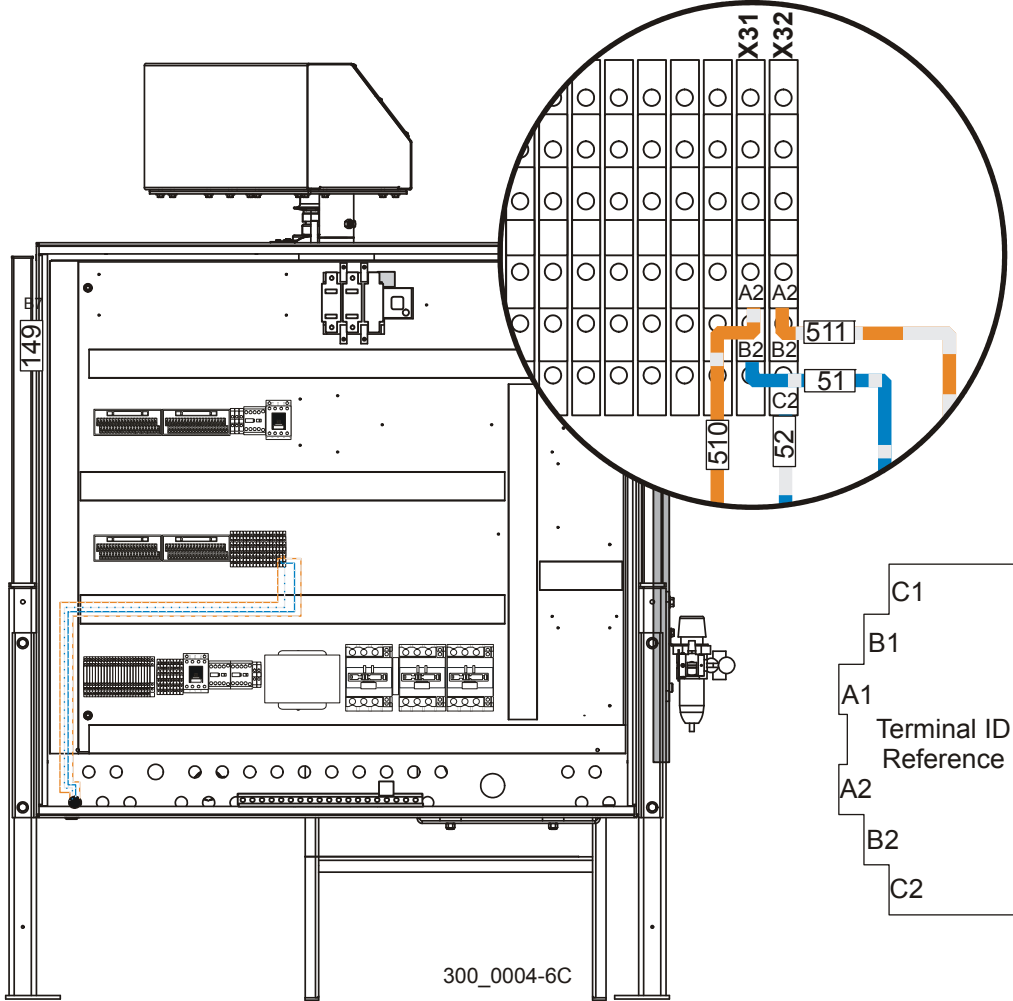


FIG. 3-32

**3.9.6 Transducer Cable**

See **Figure 3-33**. Route the transducer cable through the wireways to the terminal blocks labeled X31 and X32.

At block X31, connect wire with terminal labeled #510 to terminal #A2 and wire #51 to terminal #B2. At block X32, connect the wire with terminal labeled #52 to terminal #C2 and wire #511 to terminal #A2.



**FIG. 3-33**

# 3 Setup

## Lube System Cable

### 3.9.7 Lube System Cable

See **Figure 3-34**. Route the lube system cable wires through the wireways to the relay labeled K6 and the breaker labeled Q10.

Connect wire #70 to relay K6, terminal #2. Connect wire #69 to breaker Q10, terminal #2.

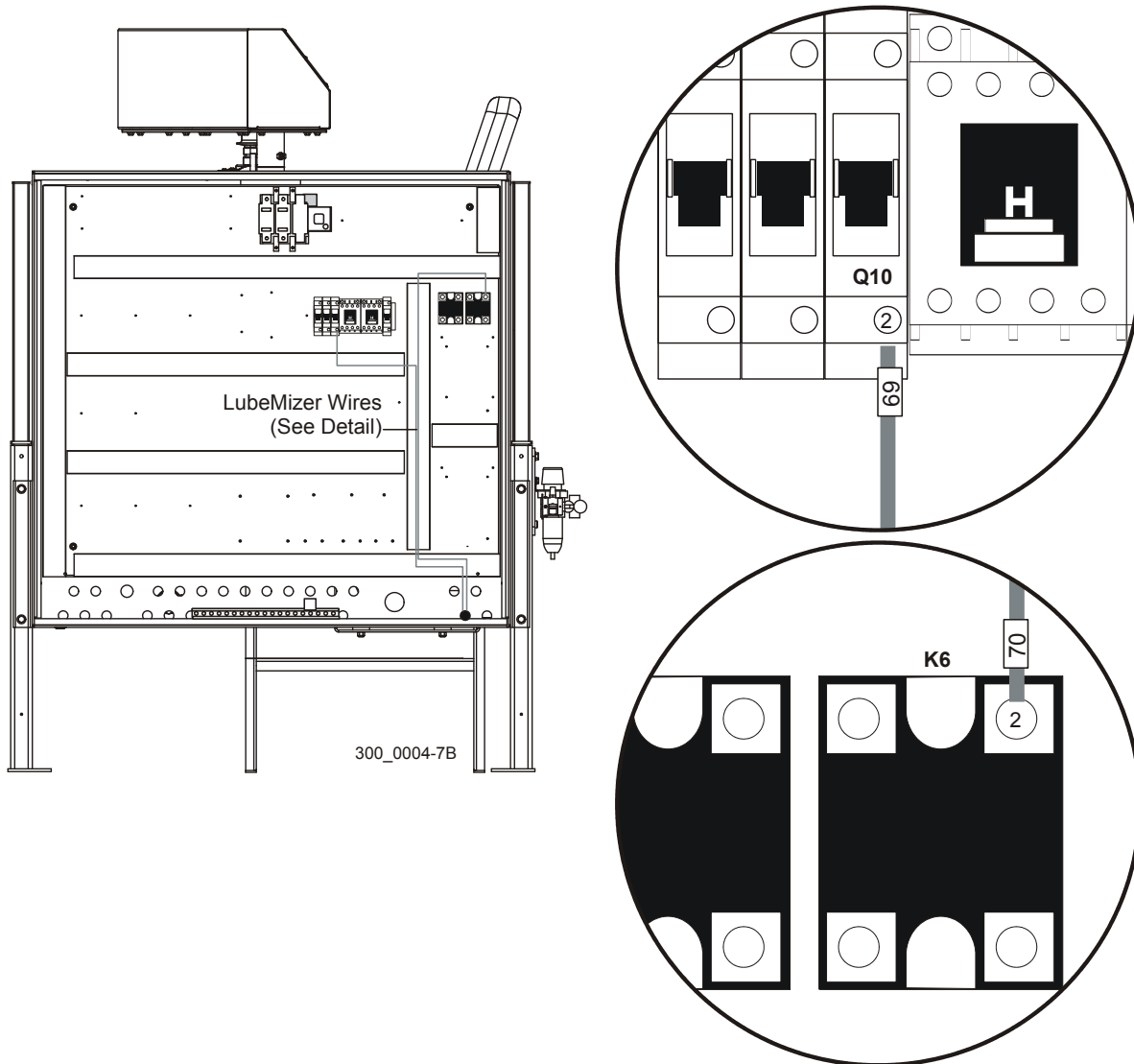


FIG. 3-34

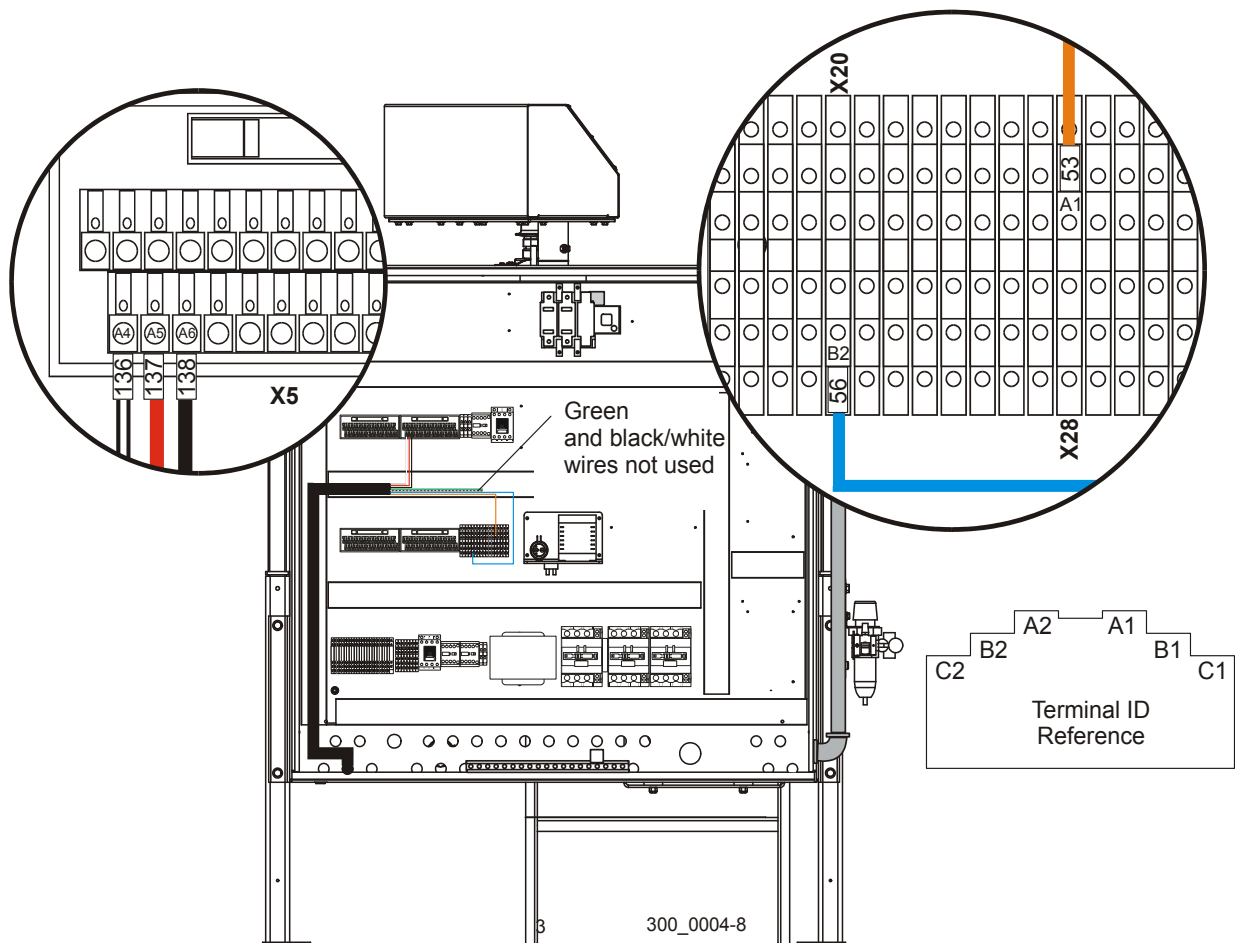


**3.9.8 Bed Sensor Cable (Rev. A1.00 - A5.01 Only)**

See **Figure 3-35**. Route the bed sensor cable wires through the wireways to the appropriate components. Route wires with terminals labeled #136, #137, & #138 to the terminal module labeled X5. Route wires with terminals labeled #53 and #56 to the terminal blocks labeled X16-X32. Route the two wires without terminals to the wireway located above the bank of contactors labeled X16-32. These wires are not used.

At terminal module X5, connect wire #136 to terminal #A4, wire #137 to terminal #A5, wire #138 to terminal #A6.

At block X20, connect wire #56 to terminal #B2. At block X28, connect wire #53 to terminal #A1.

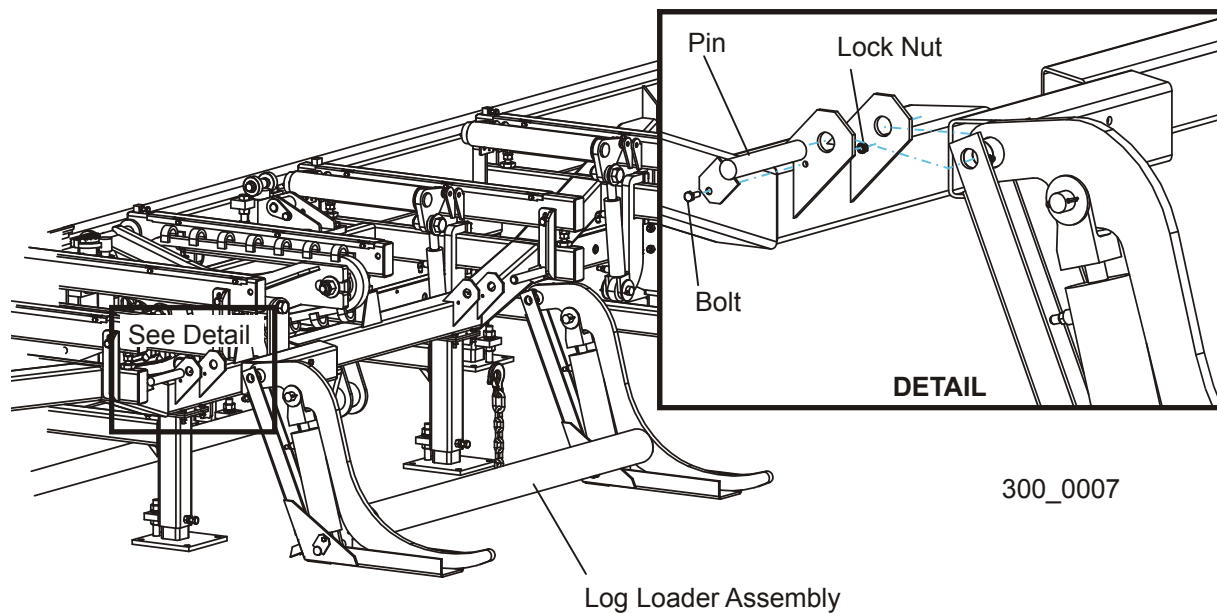


**FIG. 3-35**

Install the wireway covers after electrical installation is complete.

### 3.10 Hydraulic Installation

See **Figure 3-36**. The optional log loader assembly is disassembled from the sawmill for shipment. To install the loader, remove the two pivot pins located at the top of the assembly. Place the assembly in position between the brackets on the sawmill frame and secure with the pivot pins. Bolt the pins to the frame brackets with the supplied bolts and lock nuts.



**FIG. 3-36**

Remove the plugs from the loader hydraulic hoses and connect to the fittings on each cylinder (two hoses per cylinder).

See Figure 3-37. The hydraulic manifold is located under the operator station floor. Remove the plugs from the manifold fittings and identify the color-coded hoses extending from the sawmill frame. Remove the plugs from the hoses and connect each hose to the appropriate fitting on the manifold.

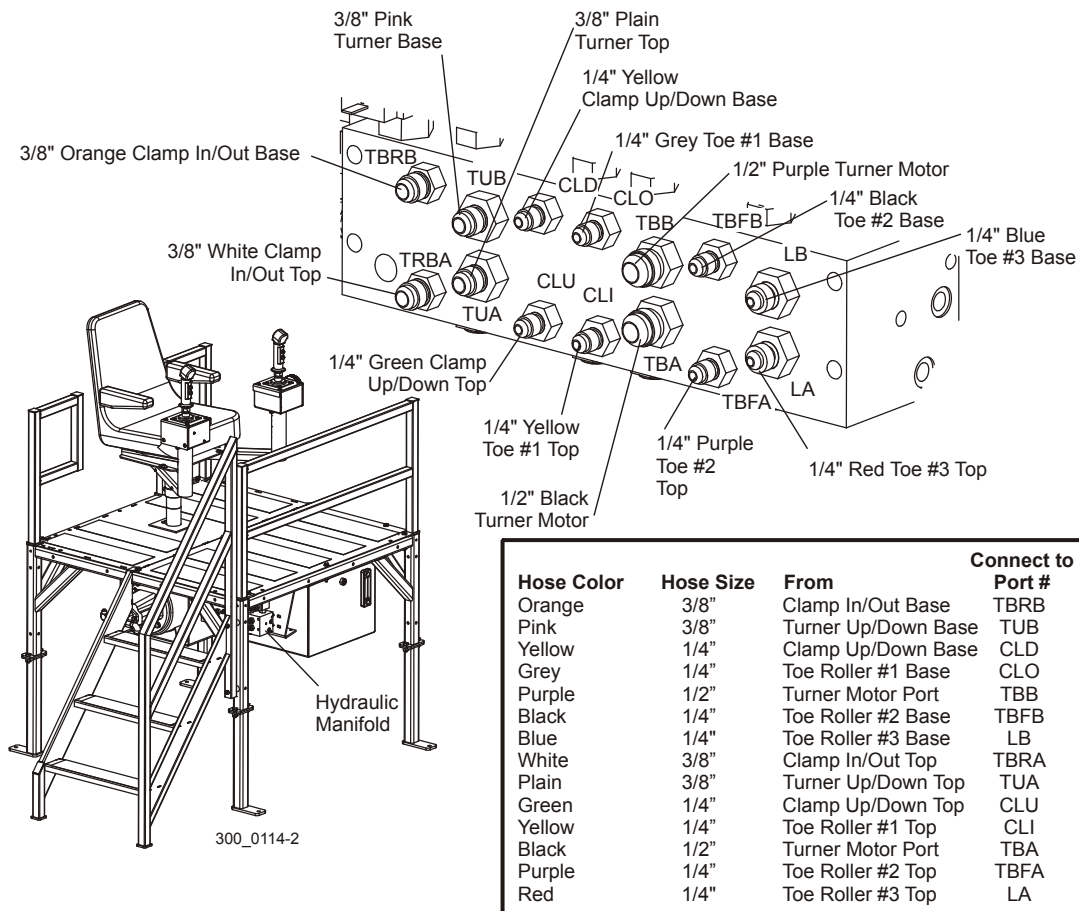


FIG. 3-37 LT300 & LT300-BX6 RETROFIT

# 3 Setup

## Hydraulic Installation

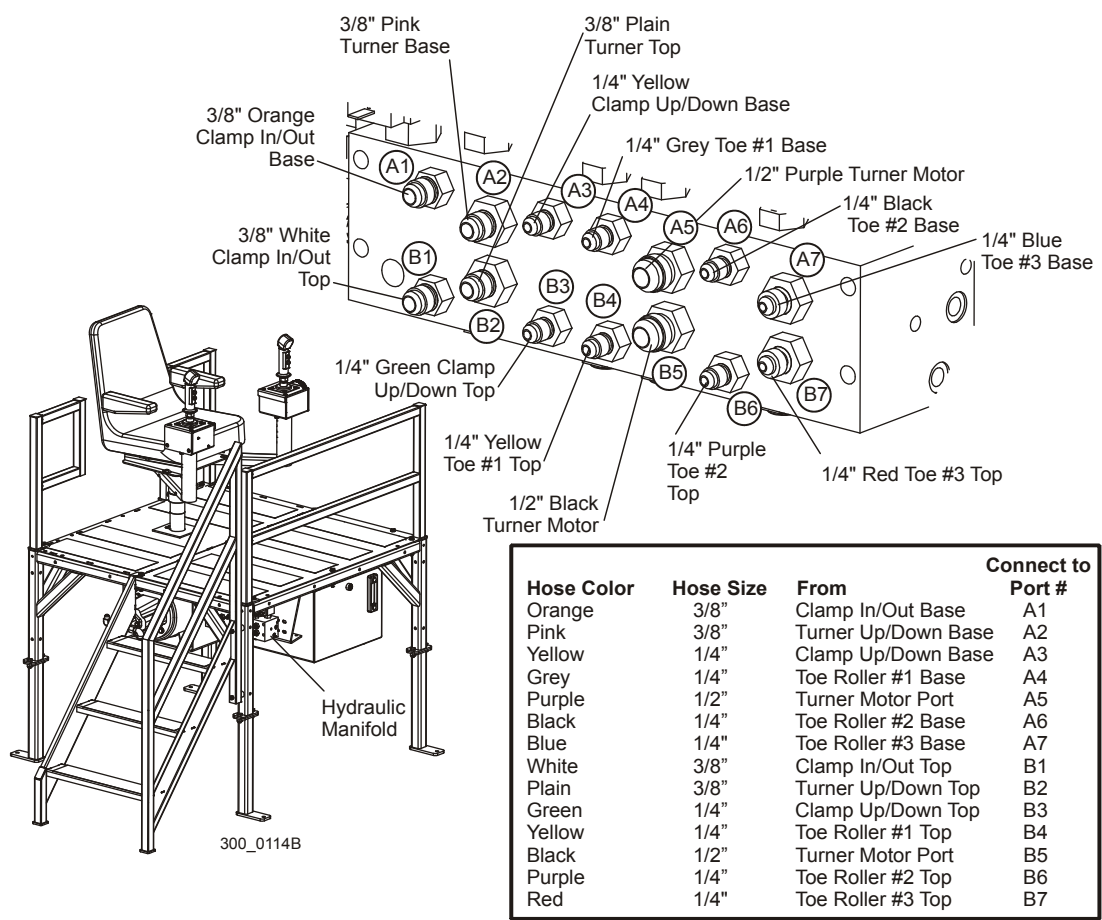
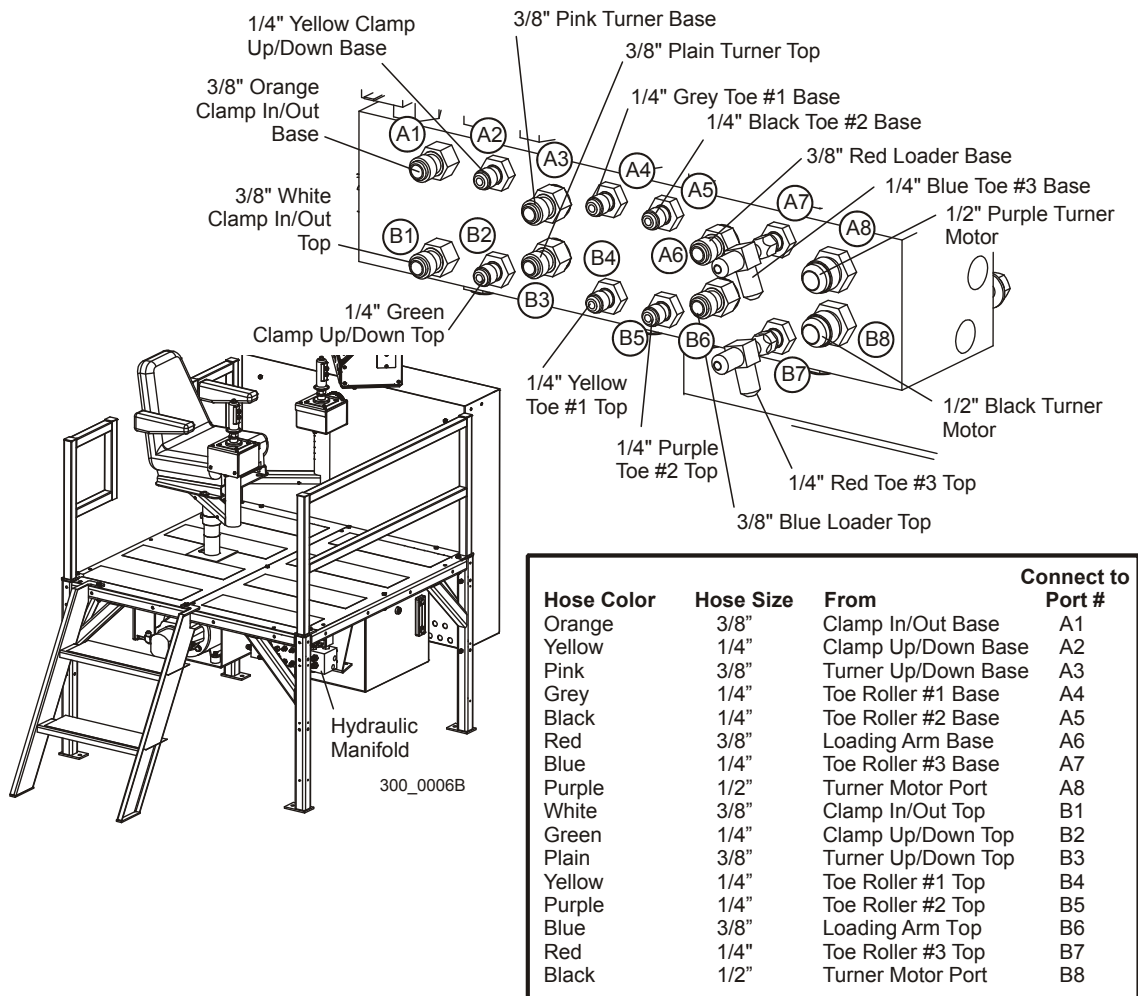


FIG. 3-37 LT300 & LT300-BX6 REV. A9.00 - B4.01



**FIG. 3-37 LT300 & LT300-BX6 REV. A1.00 - A8.00**

# 3 Setup Hydraulic Installation

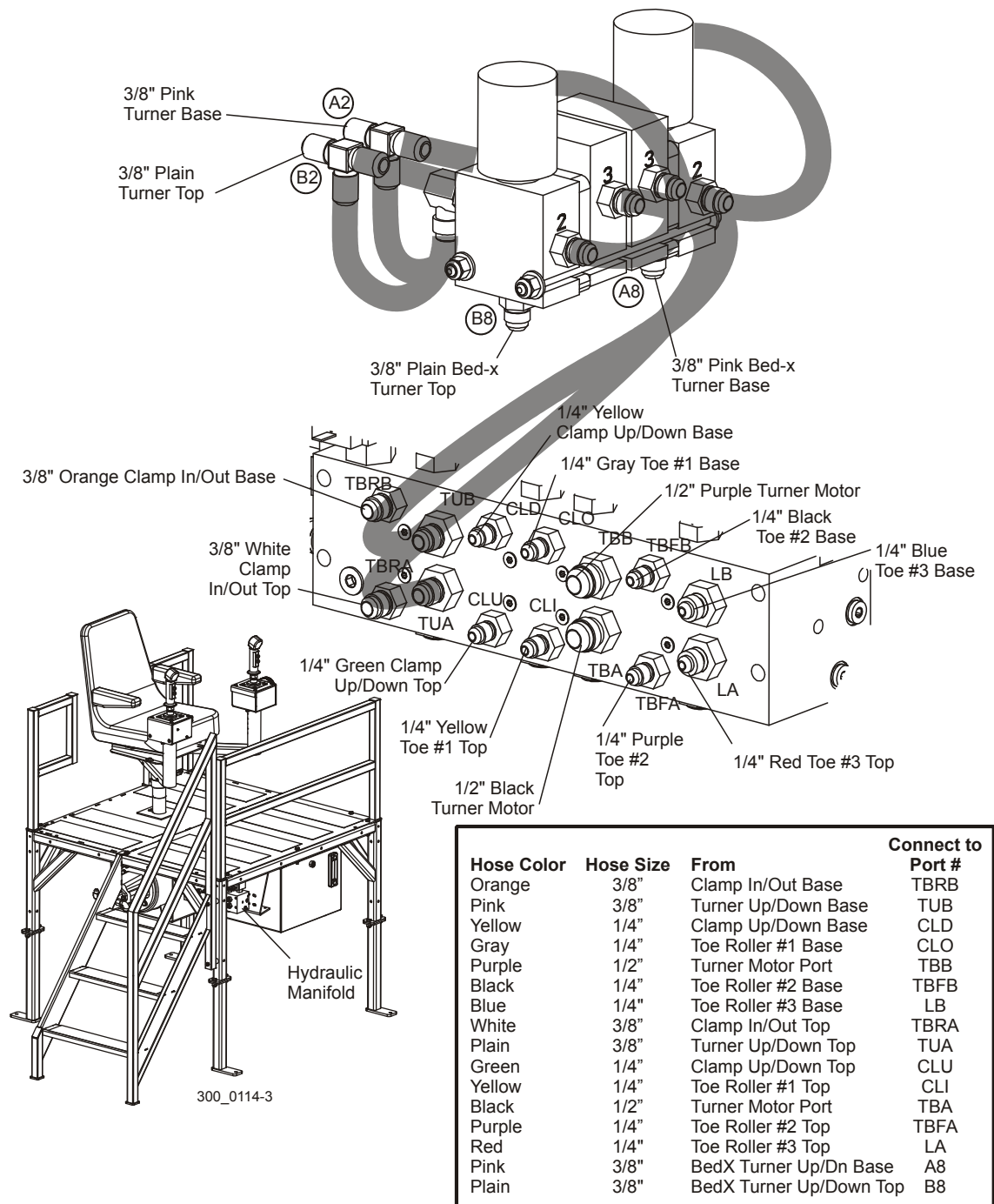


FIG. 3-37 LT300-BX10 RETROFIT

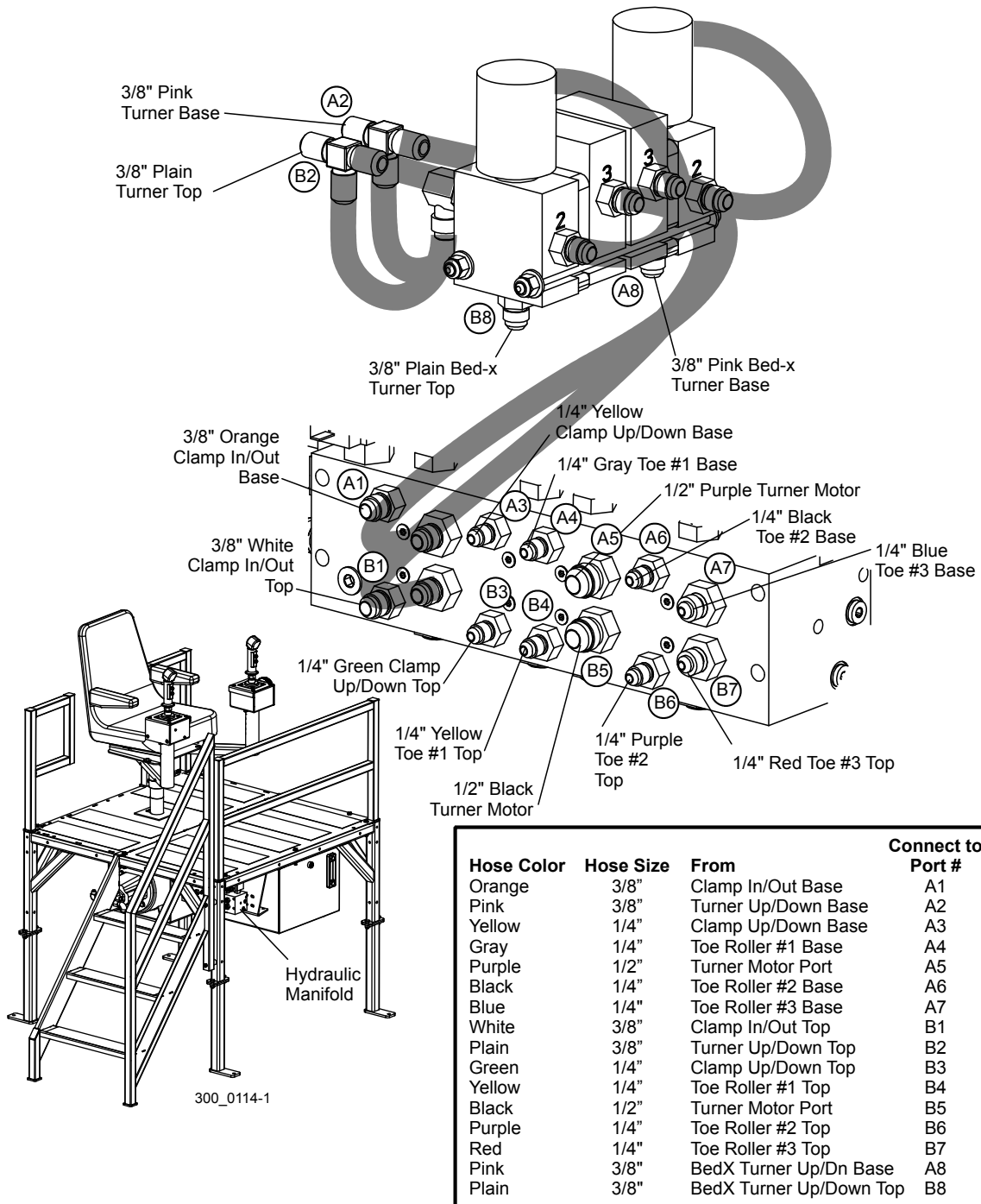


FIG. 3-37 LT300-BX10 REV. B4.01

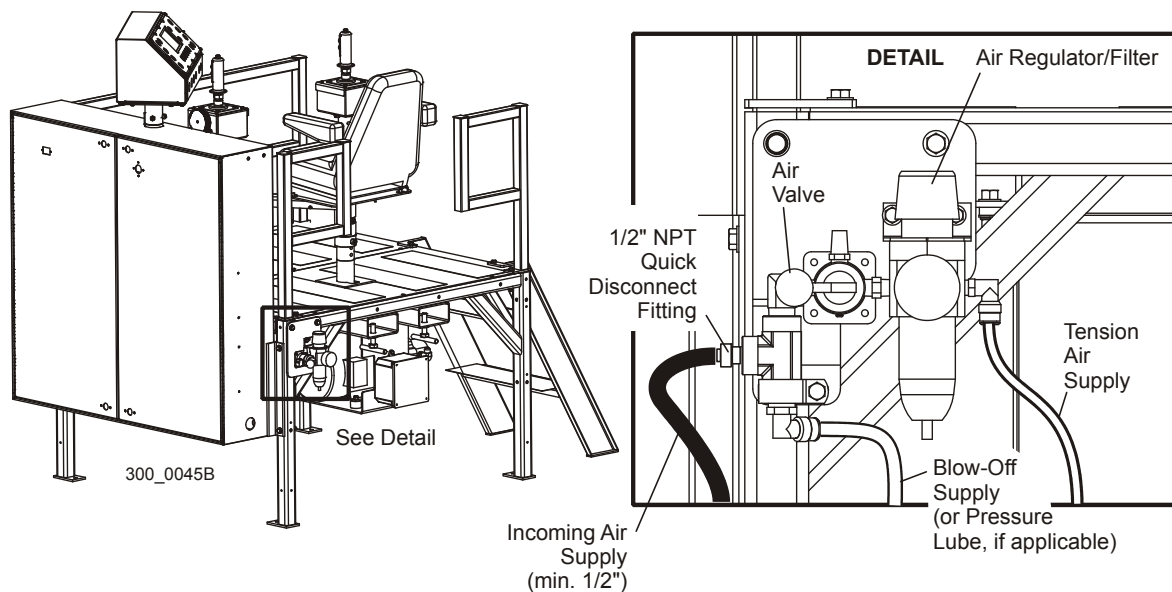
**LT300-BX10 Only:** Connect the hose from the sawmill log turner motor to the empty fitting on the extension log turner motor.



### 3.11 Air Installation

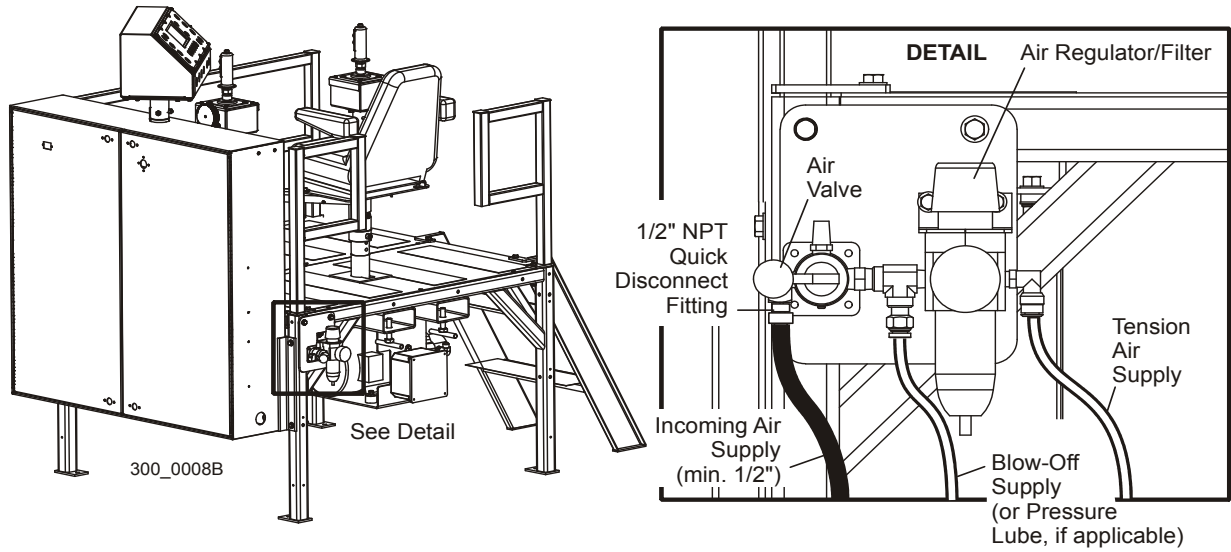
See **Figure 3-38**. Locate the air service assembly at the rear of the operator station. Install a 1/2" NPT quick disconnect fitting to the fitting supplied in the air valve. Connect the incoming air supply line (minimum 1/2" air hose) to the quick disconnect fitting. Connect the two air lines from the sawmill to the tube fittings supplied on either side of the air regulator/filter. Install the line labeled "Blow-Off Supply" to the fitting to the left of the air valve and regulator. Install the line labeled "Tension Air Supply" to the elbow fitting on the regulator. To install each line, push the fitting collar in, insert the hose and release the collar.

**NOTE:** If the sawmill is equipped with the optional Pressure Lube System, connect the 1/2" Blow-Off Supply line to the lube system fitting and connect the 1/2" hose from the lube system to the fitting to the left of the air valve ([See Section 3.6.3](#)).



**FIG. 3-38 (REV. A2.00+)**





**FIG. 3-38 (REV. A1.00 - A1.02)**

### 3.12 Sawmill Installation Setup

Once the sawmill is in place and anchored to the floor, you are ready to setup the sawmill for operation. The first step should be aligning the sawmill bed sub-frame. A transit maybe used for this procedure, however a laser-style level is recommended because it is easier and more accurate.

**NOTE:** This procedure is intended to be performed by factory personnel during initial installation using the appropriate equipment. Refer to the alignment section for subsequent adjustments to sawmill ([See SECTION 7 Alignment](#)).

#### 3.12.1 Level Sub-Frame

Set the laser level at a location so the beam is positioned five inches above the top track rail. Move the saw head so it positioned over the log clamp tube at the middle of the bed frame.



**CAUTION!** Avoid raising or lowering the saw head against the upper or lower travel limits until after the transducer has been properly adjusted ([See Section 3.13.1](#)). Failure to do so may result in damage to the machine.

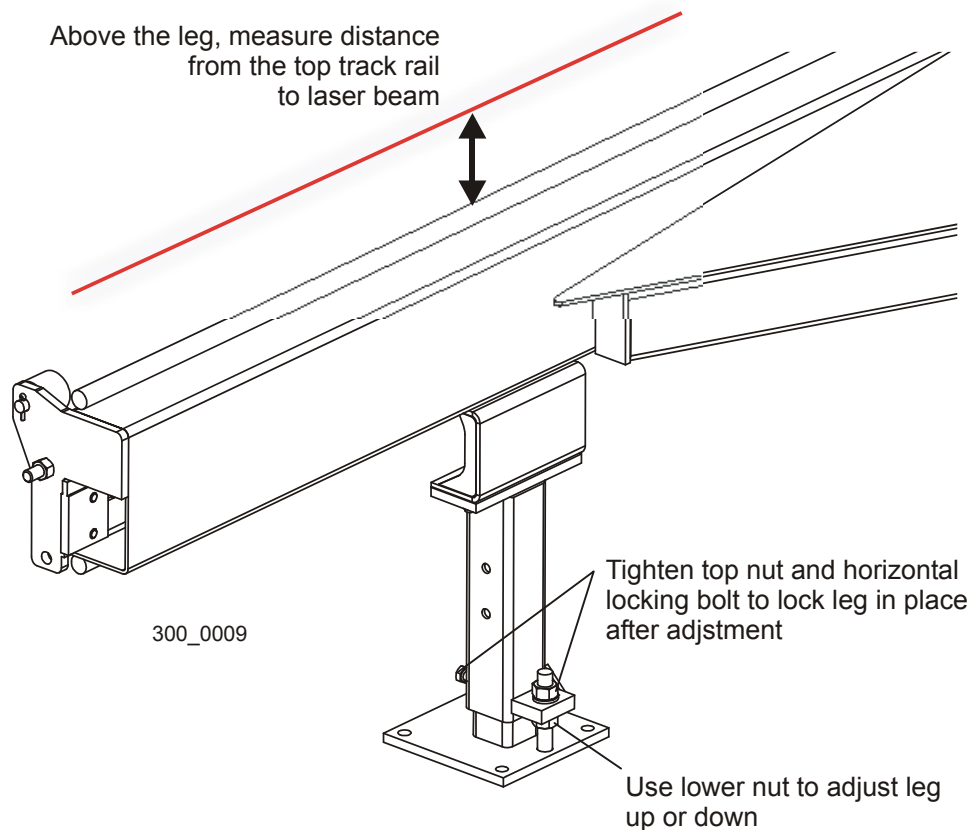
Measure the distance from the top track rail to the laser beam at four locations along the tube. Once you have four measurements, determine a target dimension that splits the difference of the four dimensions taken.

**See Table 3-4.** Suppose the four dimensions from track rail to the laser beam are as shown below. The 5 1/4" dimension should be the target as this will require the least adjustment at each location.

Front	Front Middle	Rear Middle	Rear	Target
5 1/4"	5"	5 1/2"	5 1/4"	5 1/4"

**TABLE 3-4**

**See Figure 3-39.** To level the main bed tube, measure the distance from the top track rail to the laser beam at one of the leg locations. Move the saw head if necessary to remove weight from the leg. Use the lower adjustment nut to raise or lower the appropriate leg until the target dimension is obtained ( $\pm 1/16''$ ). Lock the leg in position by tightening the top nut and the horizontal locking bolt. Repeat at each leg location along the length of the main bed tube.



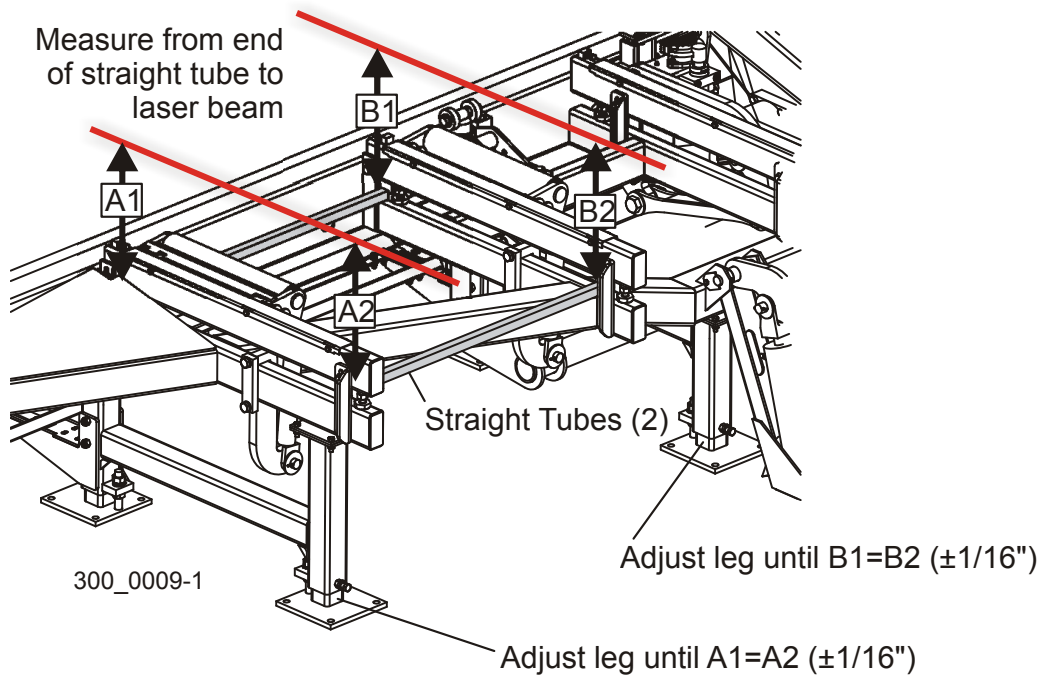
**FIG. 3-39**

After all of the legs have been adjusted and locked, move the saw head back to the rear of the bed (furthest from operator station). Measure the distance from the top track rail to the laser beam at the log clamp tube location. If the measurement is more than  $1/16''$  more or less than the target dimension determined above, adjust one of the two middle inside legs to push or pull the tube until it is level. Loosen the horizontal locking bolt and upper adjustment nut on the leg and adjust the leg using the lower adjustment nut. Retighten the top nut and horizontal locking bolt after adjustment is complete.

### 3 Setup

#### Level Sub-Frame


See **Figure 3-40**. To level the bed sub-frame in the other direction, place two pieces of straight tubing between the front two bed rail supports. Measure from the front end of each tube to the laser beam. Adjust the outer front leg to level the bed so both measurements to the tubes are the same ( $\pm 1/16$ " ). Leave the horizontal locking bolt and top adjustment nut loose for now. Repeat at the other end of the tubes using the second outer leg to adjust. Move the straight tubes to the rear two bed rail supports and adjust the two outer rear legs until the bed is level ( $\pm 1/16$  ).



**FIG. 3-40**

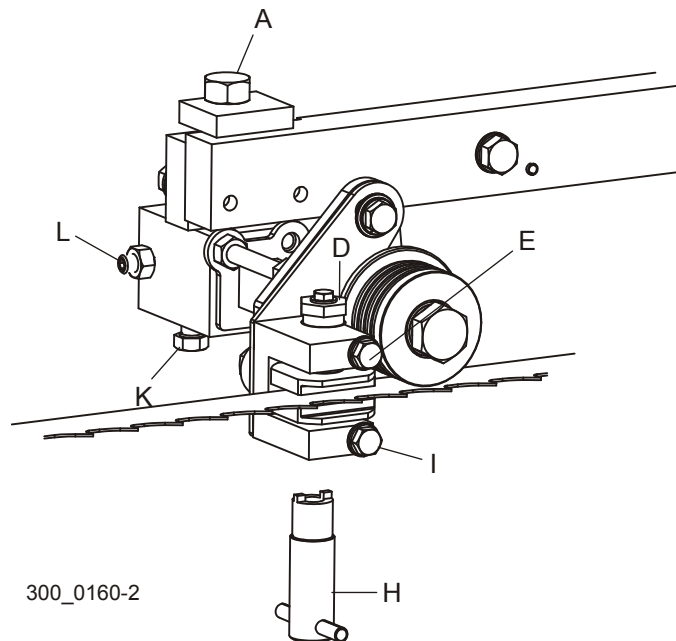
### 3.12.2 Level Saw Head

Install a blade around the blade wheels. Tension and track the blade. Move the saw carriage so the blade is positioned over the log clamp tube. Adjust the blade guide arm all the way out.

 **WARNING!** DO NOT use blades with stress cracks. Blades with stress cracks can shatter causing bodily injury and/or machine damage.

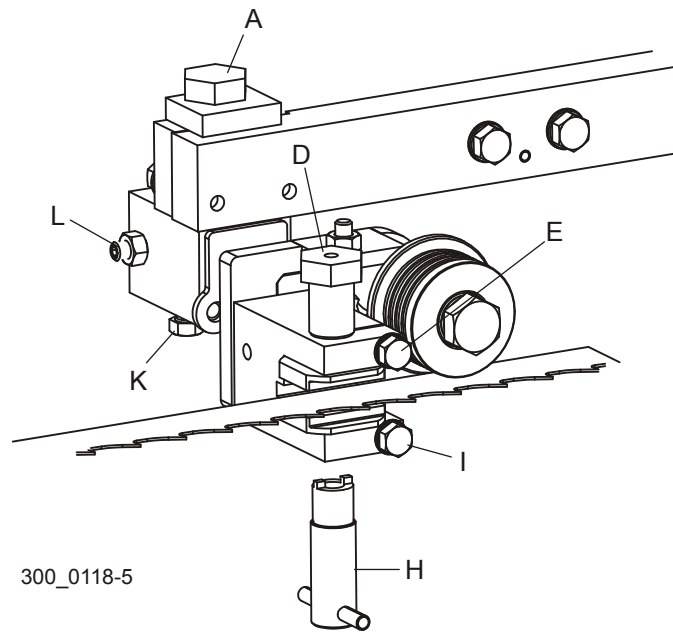
Adjust the blade guides so they do not touch the blade in any way.

**See Figure 3-41. Standard Roller/Block Guides:** Loosen clamp bolt (E) and turn the top guide block bolt (D) counterclockwise to raise the top guide block off the blade. Turn blade guide assembly bolt (A) clockwise to move the guide roller up off the blade. Loosen clamp bolt (I) and use tool (H) to turn the bottom guide block adjustment screw counterclockwise to lower block away from blade. Loosen screws (K) and (L) and move the guide assembly back away from blade.



**FIG. 3-41 LT300/WM3000 REV. B3.01+/WM3500 REV. B3.01-B6.00**

**3** Setup  
Level Saw Head

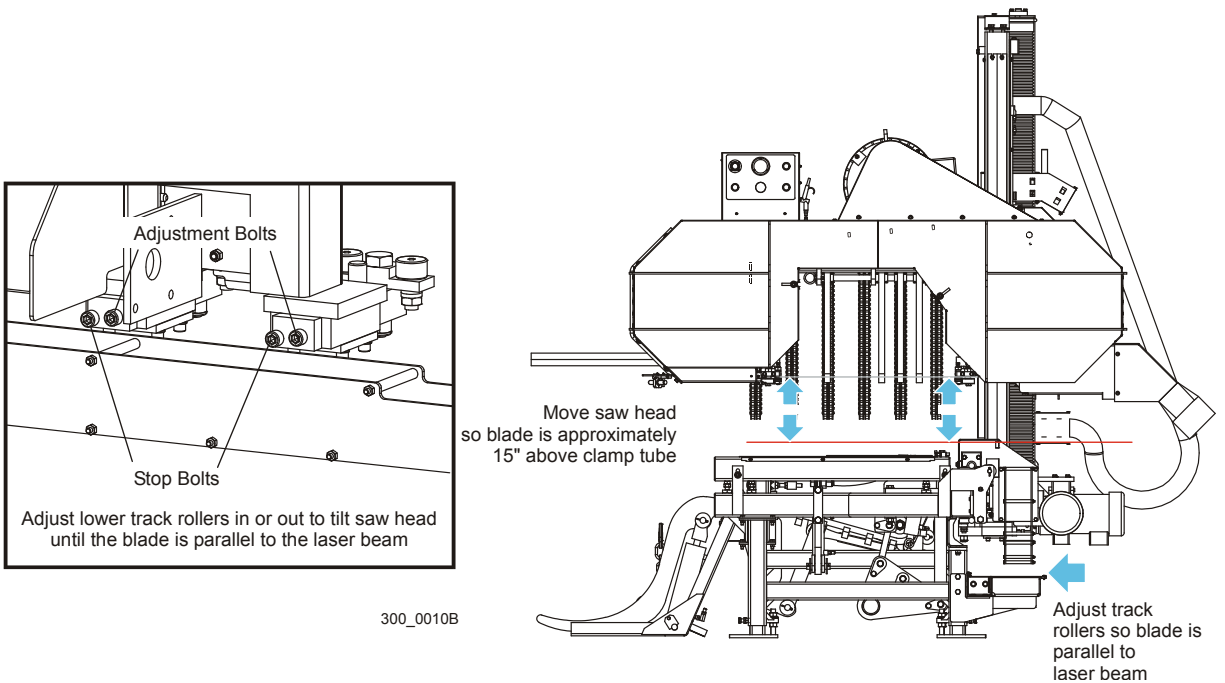


**FIG. 3-41 REV. A1.00 - B3.00**

**See Figure 3-42.** Raise the saw head until the blade is approximately 15" above the clamp tube. Hang a tape rule from the blade near the inner blade guide assembly. Make sure the tape does not contact an upward set tooth. Check the measurement from the blade to the laser beam. Move the tape rule near the outer blade guide assembly and measure to the laser beam. The two measurements should be equal. If necessary, adjust the lower track rollers to tilt the saw head so the blade is parallel to the laser beam.

To tilt the outer side of the saw head down toward the bed, loosen the adjustment bolts. Turn each adjustment bolt equally, one revolution at a time and remeasure the distance from the blade to the laser beam. Once the blade is parallel to the laser beam, tighten the stop bolts until they stop against the roller mount block.

To tilt the outer side of the saw head up, loosen the stop bolts and tighten the adjustment bolts. Turn each adjustment bolt equally, one revolution at a time and remeasure the distance from the blade to the laser beam. Once the blade is parallel to the laser beam, tighten the stop bolts until they stop against the roller mount block.

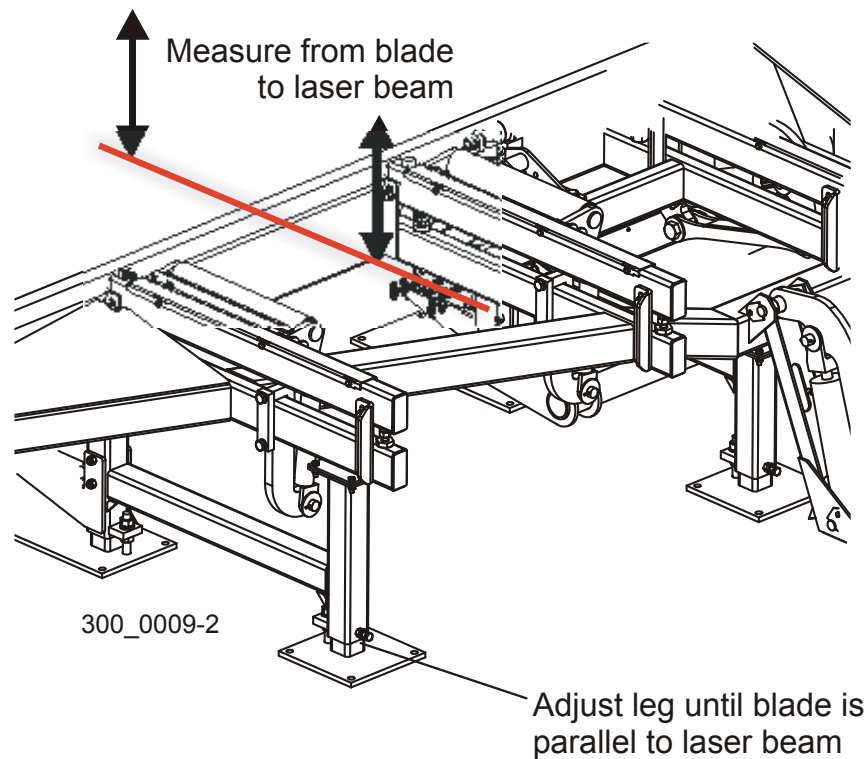


**FIG. 3-42**

# 3

## Setup Level Saw Head

**See Figure 3-43.** Now that the blade is parallel to the laser beam at the clamp location, check the alignment at each leg location along the main frame tube. Move the saw head to the first leg location and measure from the blade to the laser beam at both blade guide assemblies. If the measurements are not the same, adjust the outer leg. Turn the bottom adjusting nut to raise or lower the leg until the blade is parallel to the laser beam. Lock the leg in position by tightening the horizontal locking bolt and top adjustment nut. Repeat adjustment at each leg location down the length of the frame tube. Return to the first leg, recheck the blade alignment, fine-tune if necessary and retighten the horizontal locking bolt and top adjustment nut.

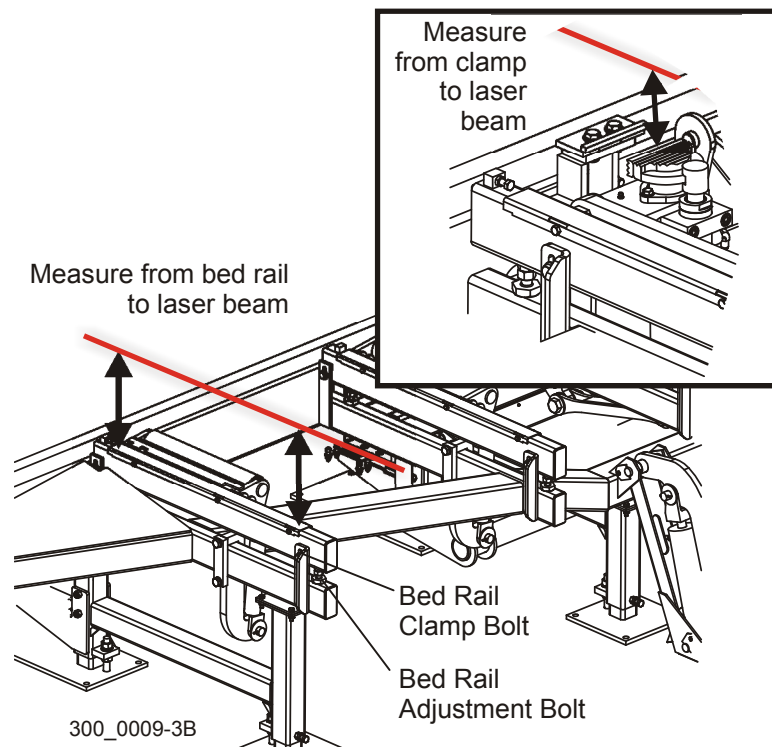


**FIG. 3-43**



### 3.12.3 Level Bed Rails

**See Figure 3-44.** Adjust the bed rails to  $5/16$ " above the log clamp. Move the log clamp in until it is 10" from the clamp stop. Adjust the clamp down to its lowest position. Measure the distance from the laser beam to the clamp (i.e. 5"). Measure the distance from the first bed rail to the laser beam at both ends of the bed rail. If necessary, loosen the bed rail clamp bolts and turn the adjustment bolt to raise or lower the end of the bed rail so it is  $5/16$ " above the clamp (i.e.  $4 \frac{11}{16}$ " [ $\pm 1/16$ "]). Retighten the bed rail clamp bolts. Repeat adjustment as necessary at each bed rail.



**FIG. 3-44**

Move the saw head so the blade is positioned over the first bed rail. Open the blade guide arm all the way open. Measure from the bottom of the blade to the bed rail at each end of the rail. If the two measurements differ by more than  $1/16$ ", recheck the measurement from the bed rail to the laser beam and adjust the bed rail as necessary. Move the saw head to each bed rail and repeat procedure until all bed rails are parallel to the blade and laser beam within  $1/16$ ".

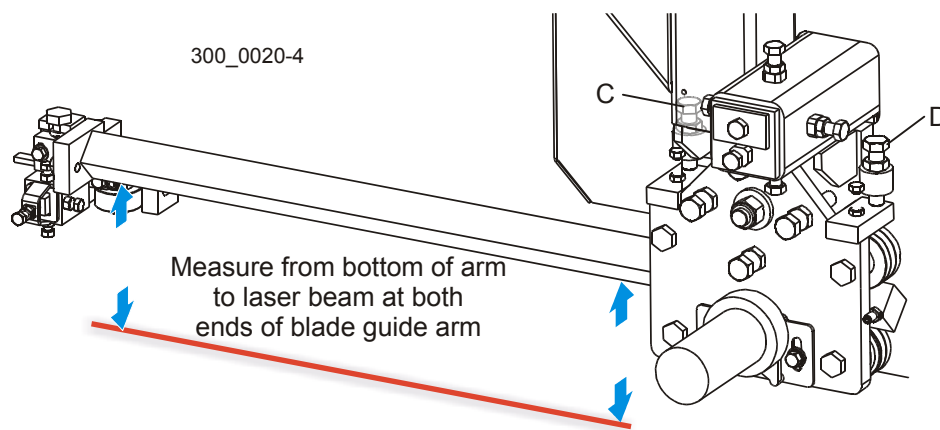
# 3

## Setup

### Level Blade Guide Arm

#### 3.12.4 Level Blade Guide Arm

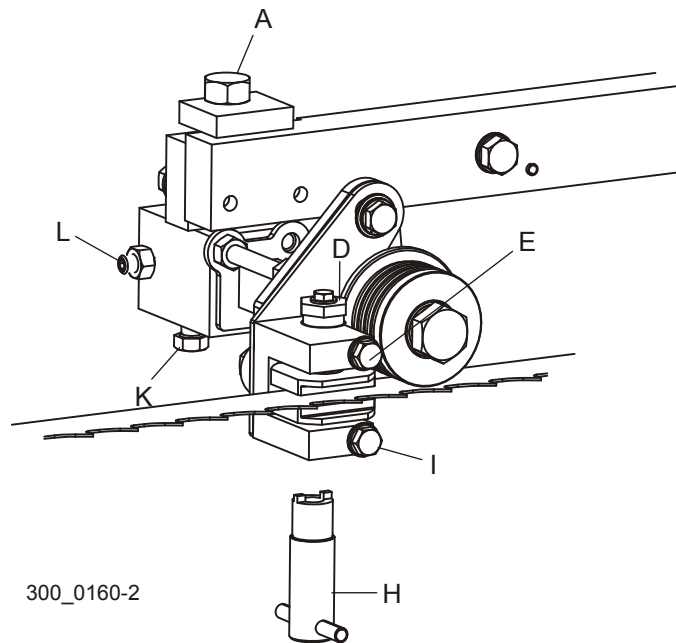
See **Figure 3-45**. Adjust the blade guide arm all the way in. Measure from the bottom of the arm to the laser beam at both ends of the arm. The two measurements at each end of the arm should be the same within  $1/32''$ . To adjust the vertical tilt of the arm, adjust the bolts (C & D) on the blade guide arm mounting plate. Loosen the jam nuts. Adjust bolt (C) up and bolt (D) down to tilt the arm up. Adjust bolt (D) up and bolt (C) in to move the arm toward the blade. Recheck the distance from the arm to the laser beam at both ends of the arm. Readjust if necessary. Tighten the jam nuts.



**FIG. 3-45**

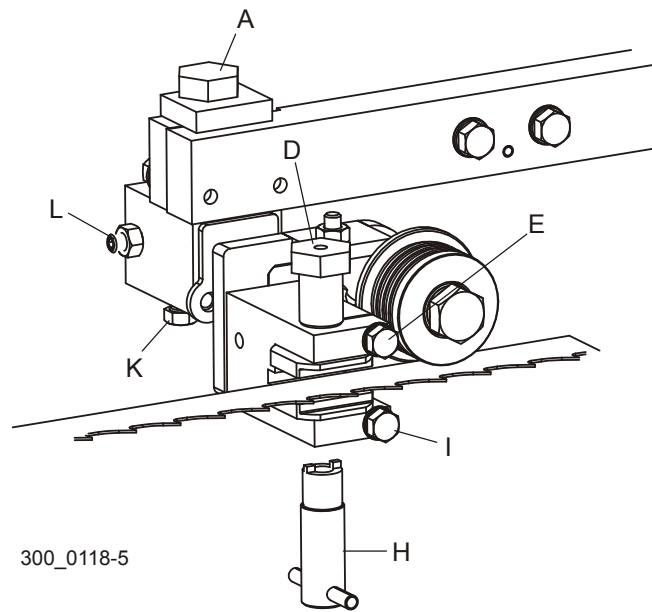
**Adjust the blade guides for sawing.**

**See Figure 3-46.** Standard Roller/Block Guides: Move the guide assembly forward until the roller flange is 1/16"-1/8" from the back edge of the blade and tighten clamp bolts (L) and (K). Turn blade guide assembly bolt (A) counterclockwise to lower the guide roller until it deflects the blade down 1/4". Turn top guide block bolt (D) clockwise to move top block down to **.008" - .010" from top of blade (use provided shim to set distance)**. Tighten clamp bolt (E). Use tool (H) to turn lower block adjustment screw clockwise to raise bottom block to **.008" - .010" from bottom of blade**. Tighten clamp bolt (I). Repeat for other blade guide assembly.



**FIG. 3-46 LT300/WM3000 REV. B3.01+/WM3500 REV. B3.01-B6.00**

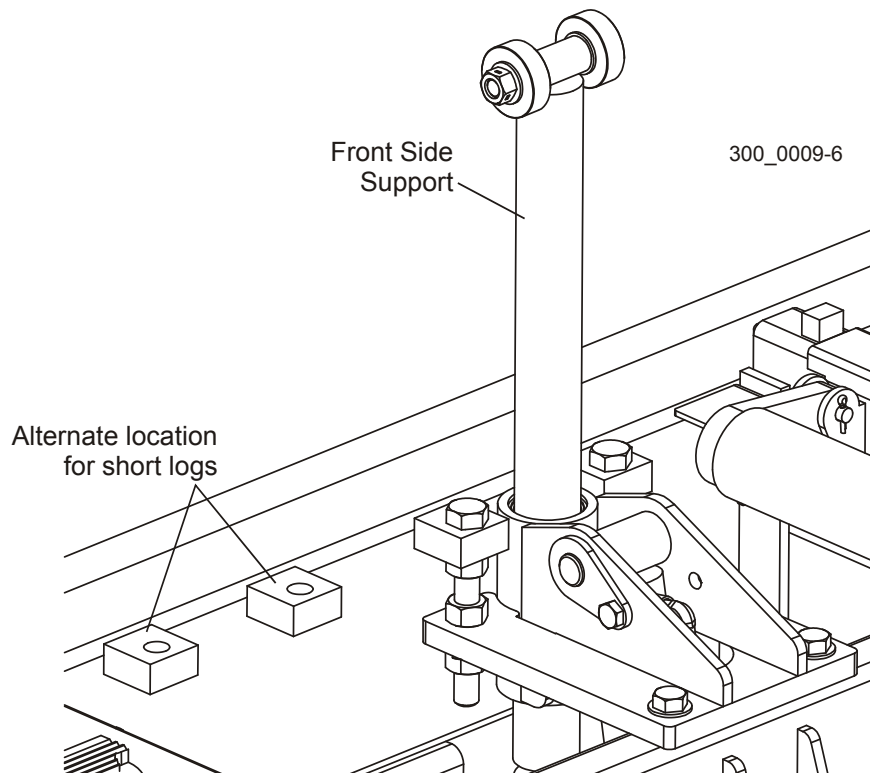
**3** Setup  
Level Blade Guide Arm



**FIG. 3-46 REV. A1.00 - B3.00**

**3.12.5 Side Support Setup**

**See Figure 3-47.** An alternate location for the front side support is available to use if you handle short logs (less than 8 feet long). Unfasten the front side support from the link bar and unbolt the assembly from the bed frame. Relocate the assembly to the alternate position and secure with the previously removed hardware. Check the side support alignment ([See Section 7.1.5](#)).



**FIG. 3-5**

### 3.13 Initial Control Programming

After the sawmill is installed and ready to operate, the control should be programmed. Reprogramming will also be required if the control CPU or transducer sensor is replaced.


#### 3.13.1 Blade Height Calibration

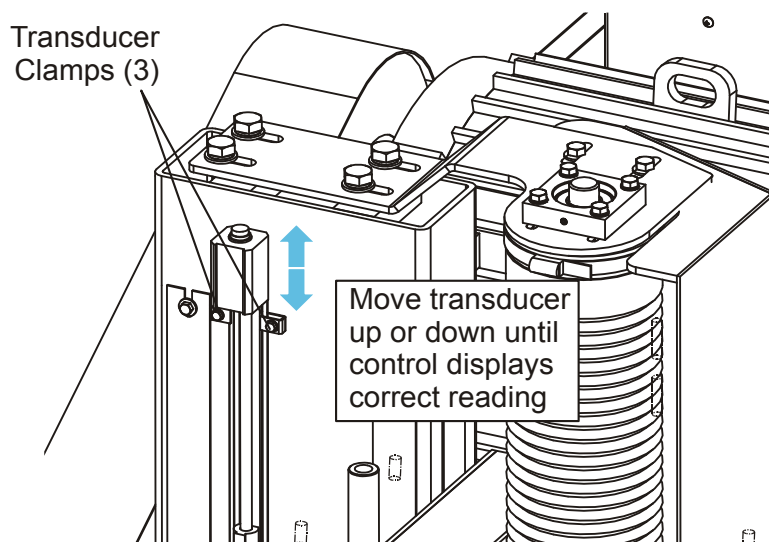
Perform the three procedures described below to ensure that the control accurately displays the position of the blade above the bed rails. Push the green START button to activate the machine.

##### Sensor Calibration

1. Move the saw head so the blade is positioned 1" - 1 1/2" from a bed rail.
2. Use a tape rule to measure the actual distance from a bed rail to a down-set tooth on the blade (measure at a point over the bed rail closest to the saw head mast).
3. Check the display reading on the sawmill control. If the reading does not match the actual measurement, adjust the transducer located on the saw head mast.

**See Figure 3-48.** Loosen the three transducer clamp brackets and slide the transducer up or down until the control displays the correct reading. This is easiest done with a second person sitting at the control as you adjust the transducer. Tighten the clamp brackets to secure the transducer in position.

 **CAUTION!** Do not overtighten the sensor bracket screws. Damage to the sensor may result.



**FIG. 3-48**

### Sensor Linearity Adjustment

**NOTE:** Perform the Sensor Calibration procedure described above prior to checking and adjusting the Sensor Linearity.

1. Raise the saw head so the blade is positioned approximately 1" below the top stop.
2. Measure the distance from the same down-set tooth to the bed rail and compare to the reading on the display. If the measurement and display reading differ more than  $1/32$ ", adjust the sensor Cal Value as described in the next steps.

**NOTE:** The Calibration value is recorded on the transducer sensor housing located at the top of the saw head mast. In most cases, this value is what should be entered into the control.

3. Turn the key switch to the Program position and push the Ref Lock button to display the Cal Value. The value is displayed in whole numbers. Each increment of 5 is equal to approximately  $1/32$ ".
4. Use the Up or Down buttons to adjust the value. If the actual measurement from the blade to the bed rail was greater than the displayed height value, increase the Cal Value. If the actual measurement was less than the displayed height value, decrease the Cal Value.
5. Press the Select button to store the new value. Record the value for future reference: Cal Value \_\_\_\_\_.
6. Turn the key switch to the Off position and verify that the displayed height value is now the same as the actual distance from the blade to the bed rail (within  $1/32$ "). Repeat the Linearity Value adjustment as necessary.
7. Repeat the Sensor Calibration and Sensor Linearity adjustments until the correct height value is displayed with the saw head at the lower and upper ends of the mast.

### Final Sensor Check

1. Move the saw head so the blade is between 17" and 18" from the bed rail.
2. Measure the distance from a downset tooth on the blade (measure at a point over the bed rail closest to the saw head mast).
3. Verify that the displayed height value is the same as the actual measurement from the blade to the bed rail (within  $1/32$ "). If not, repeat the Sensor Linearity Adjustment procedure above, then repeat the Final Sensor Check.

### **3.13.2 Upper Saw Head Travel Limit**

This option is available if the area where the sawmill is installed does not have enough height clearance to allow the saw head to travel to the top of the mast. To set the Upper Saw Head Travel Limit, first position the saw head at the height where you want it to automatically stop. Turn the key to the Program position and push the Ref 2 button. Push the Select button to set the limit at the current saw head position.

### **3.13.3 Power Feed Calibration**

Calibrate the power feed dial. With the key switch still in the Program position, push the Next Cut (or Last Cut) button. Turn the power feed dial in one direction until it stops. Push the Select button. Turn the power feed dial the other direction until it stops and push Select again.

### **3.13.4 Kerf**

The kerf value is automatically added to the board thickness setting to compensate for the thickness of the blade. The default factory value is .19. Adjustment of this value may be necessary if you use different thicknesses of blades or unusual tooth set configurations. Push the Up or Down buttons to adjust the value and push Select to store the new value.



## SECTION 4 OPERATION

### 4.1 Control Overview

The LT300 control was designed to allow the operator to control the sawing operation with minimal effort and movement.

**See Figure 4-1.** The control includes several sets of buttons for controlling how the sawmill is programmed to cut a log. The control box also includes controls to start and stop the machine. A description of each control component is provided below.

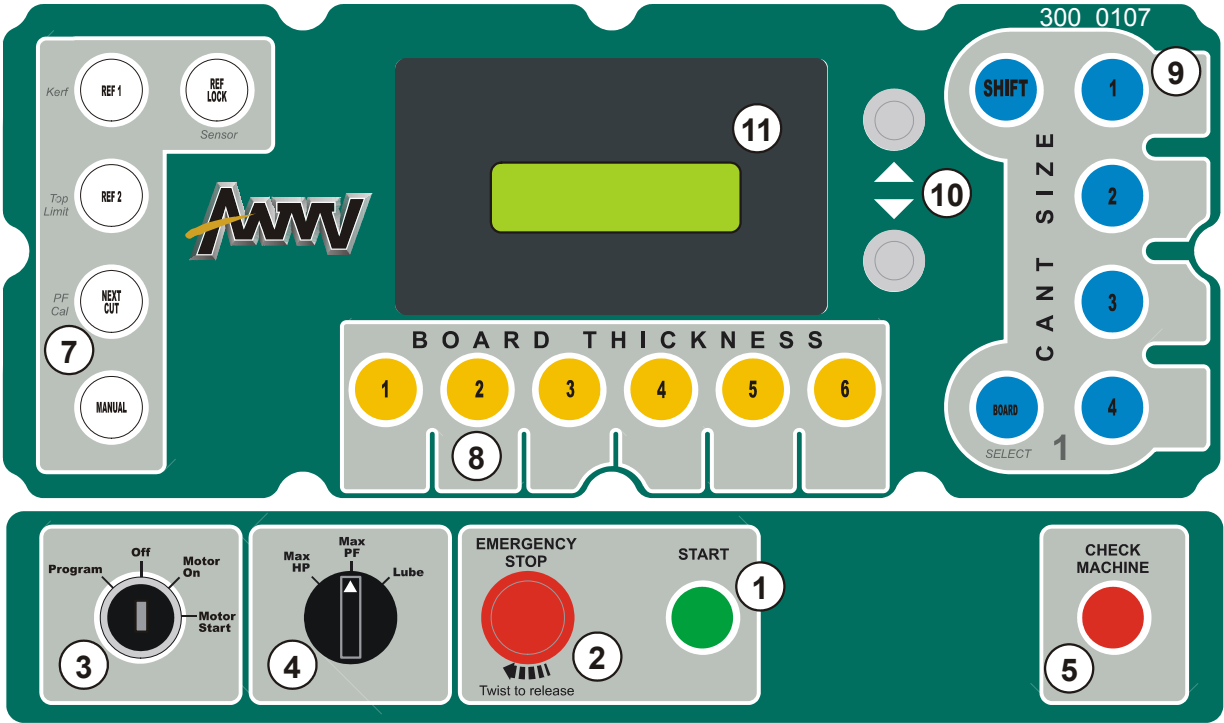


FIG. 4-1 REV. A9.00+

# 4 Operation

## Control Overview

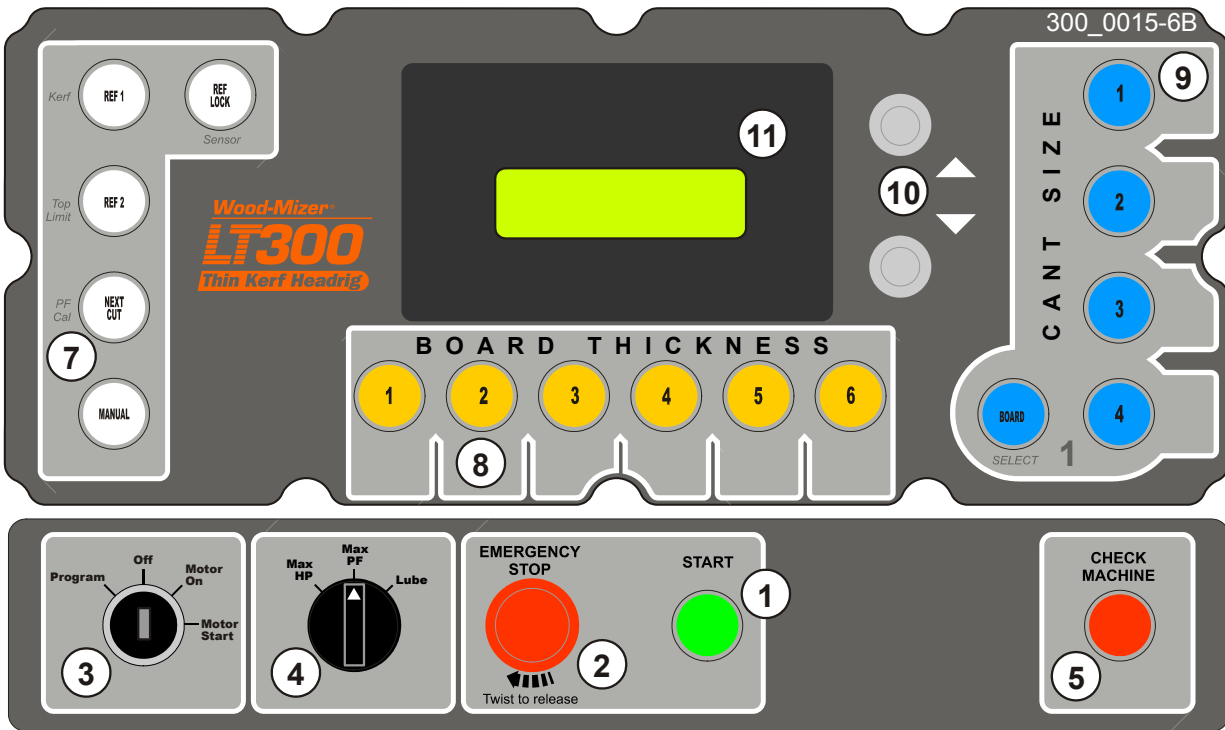


FIG. 4-1 REV. A6.00 - A8.00

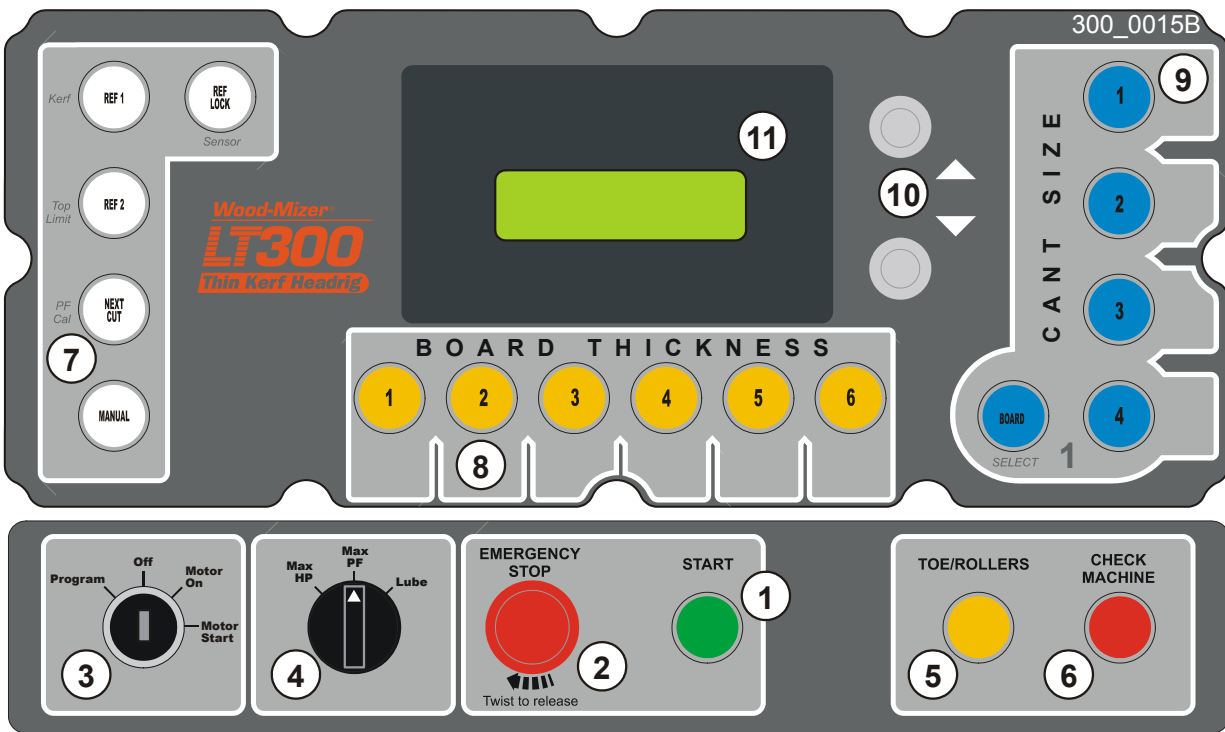


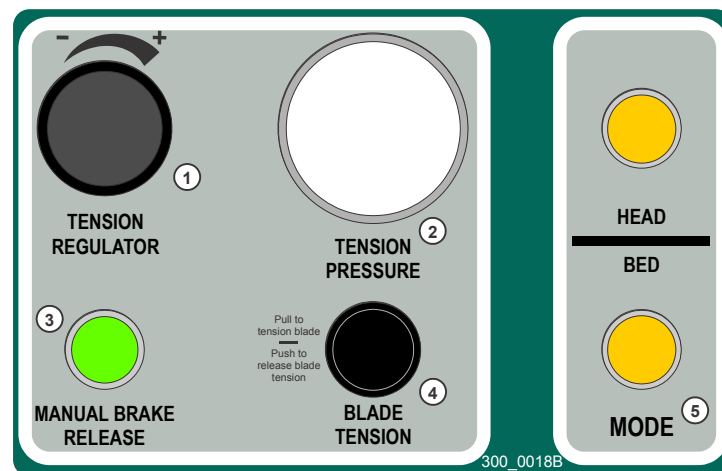
FIG. 4-1 REV. A1.00 - A5.01

1. START - Push the START button to turn on electrical power to the machine.
2. EMERGENCY STOP - Push this button to turn off electrical power to the machine. To release the stop, turn the button clockwise and release so the button pops up.
3. Key Switch - Turn the key switch to MOTOR START to start the blade motor. Release the key to the MOTOR ON position to allow the blade motor to continue running. Turn the key switch to OFF to stop the blade motor. Use the PROGRAM position of the key switch to reprogram certain controls described later.
4. Selector Switch - Allows the operator to specify values for the MAX HP, MAX PF, and LUBE pulse. These options will be explained later in the manual.
5. TOE/ROLLERS - **Rev. A1.00 - A5.01 Only:** This light warns the operator that one or more bed rollers are up when pattern cutting.
6. CHECK MACHINE - This light warns the operator that a problem has occurred. The specific problem will be indicated on the display.
7. Temporary Reference Buttons - Programmable buttons used to store a location of the blade and reference from that position (not the bed). Mostly used when sawing for grade where the outer perimeter of the log contains the highest-quality boards.

- REF LOCK (Sensor)
  - REF 1 (Kerf)
  - REF 2 (Top Limit)
  - NEXT CUT (PF Cal). Was "LAST CUT" before 3/04.
  - MANUAL
8. BOARD THICKNESS - Six programmable buttons the operator can use to automatically drop the blade a pre-determined distance. A dry-erase marker can be used to temporarily label the area below each button with its value.
9. CANT SIZE (Pattern Mode) - Four programmable buttons that allow the networks to reference the blade to the bed. Typically used when dimensional sawing or finishing a hardwood log to a finish sized cant. A dry-erase marker can be used to temporarily label the area to the right of each button with its value.
- Rev. A9.00+:** The SHIFT button allows twelve settings for the four pattern buttons. Push the SHIFT button once. The SHIFT button will illuminate indicating pattern settings 5-8 are active. Push the SHIFT button a second time. The SHIFT button will flash indicating pattern settings 9-12 are active. Push the SHIFT button again to turn off and return to pattern settings 1-4.
10. Up/Down Buttons - Used to increase or decrease values when programming the control.
11. Display - During the sawing operation, the display shows the current blade height location and the board thickness values currently being used. The display also displays error messages or values of certain features when the control is being programmed.

## 4.2 Distribution Box Overview

See **Figure 4-2**. The distribution box on the saw head contains controls for the blade tension. The box also includes lights that indicate which mode (head or bed) the joystick controls are currently set to. The control box also includes controls to start and stop the machine. A description of each box component is provided below.



**FIG. 4-2**

1. **TENSION REGULATOR** - Turning this knob adjusts the blade tension pressure. Pull the knob out to unlock it and turn the knob clockwise to increase blade tension, counterclockwise to reduce blade tension. When finished changing the pressure, push the knob back into to lock it.
2. **TENSION PRESSURE** - Gauge indicates current blade tension pressure.
3. **MANUAL BRAKE RELEASE** - Push in and hold to release the blade wheel brake. **NOTE:** When control power is off the blade brake is engaged. When changing blades it is sometimes necessary to spin the blade wheels. To manually release the blade brake, press and hold the button. Release the button to engage the brake again.
4. **BLADE TENSION** - Pull out to tension the blade tension, push in to release the tension.
5. **MODE** - Two lights indicate the current mode of the joystick controls. The top button on the left joystick toggles the joystick controls between head and bed functions.
  - **HEAD** - When lit, the joystick controls are in head mode. The joysticks can be used to operate saw head functions (saw head up, down, forward, reverse, cruise control, board blow-off and blade guide arm in or out).
  - **BED** - When lit, the joystick controls are in bed mode. The joysticks can be used for

# 4

## Operation

### *Distribution Box Overview*

---

log handling functions (loader, clamp, turner, side supports and rollers).

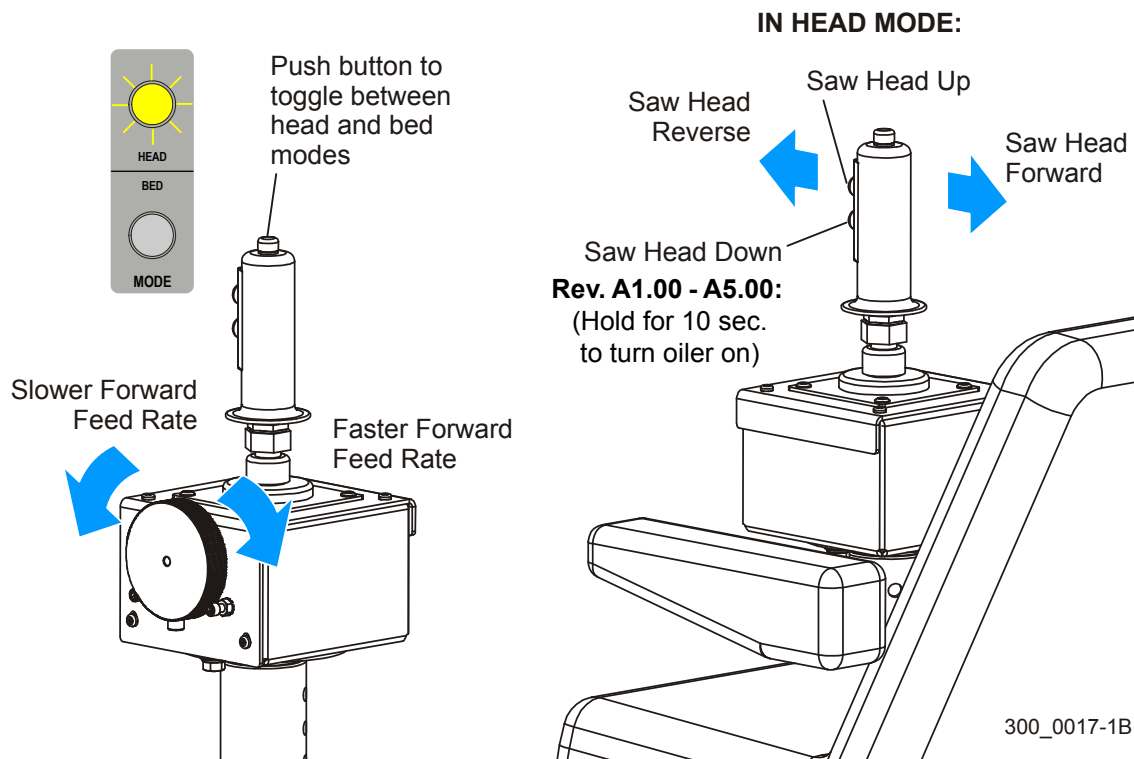
### 4.3 Joystick Control Overview

The joysticks located at the operator seat control all of the saw head and bed functions. Each joystick can be moved forward, backward, left and right to perform various functions. Each joystick also has three buttons to perform additional functions. One button is located at the top of the joystick and two on the side of the joystick.

To toggle between head and bed functions, push the button at the top of the left joystick. The MODE light on the saw head distribution box will indicate if the controls are in bed mode or head mode.

**See Figure 4-3.** In HEAD mode, push the right joystick forward to move the saw head away from the operator station. **Rev. A1.00 - A5.00 only:** Hold the joystick forward for 10 seconds to turn on the oiler. Pull the right joystick back to bring the saw head forward toward the operator station (cutting direction). Rotate the feed rate dial next to the left joystick to adjust the speed of the saw head in the cutting direction. Rotate the dial toward you to speed up the feed rate, away from you to slow the feed rate down. The saw head automatically moves in reverse at full speed.

Push the top side button on the right joystick to raise the saw head and push the bottom side button to lower the saw head.



**FIG. 4-3**

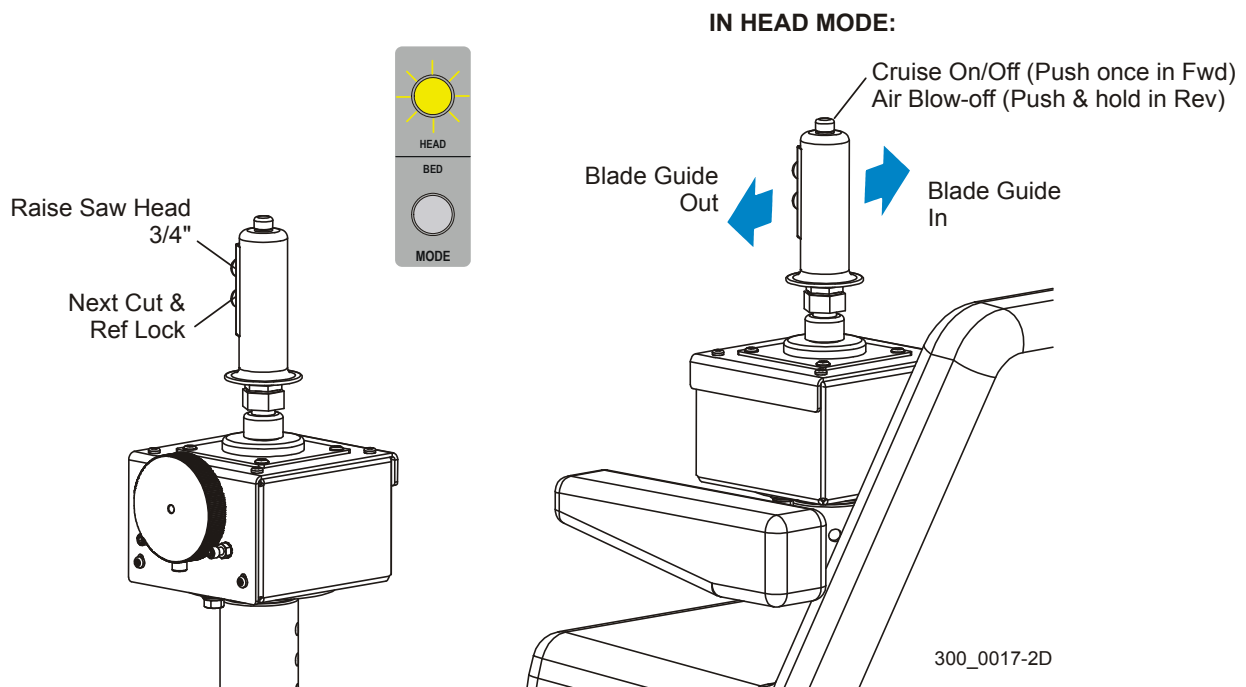
## 4 Operation

### Joystick Control Overview

**See Figure 4-4.** The right joystick also adjusts the outer blade guide arm in and out. Push the joystick to the right to move the blade guide in toward the log. Push the joystick to the left to move the blade guide out away from the log.

Pushing the top button on the right joystick once with the saw head moving forward turns the cruise on and off. Pushing and holding the button with the saw head moving in reverse turns the air blow-off on to blow sawdust off the wood.

The top side button on the left joystick raises the saw head 3/4" so you can return the saw head after a cut without dragging the blade. The bottom side button enables the NEXT CUT (or LAST CUT) and REF LOCK networks controls. These functions are described later in the manual.

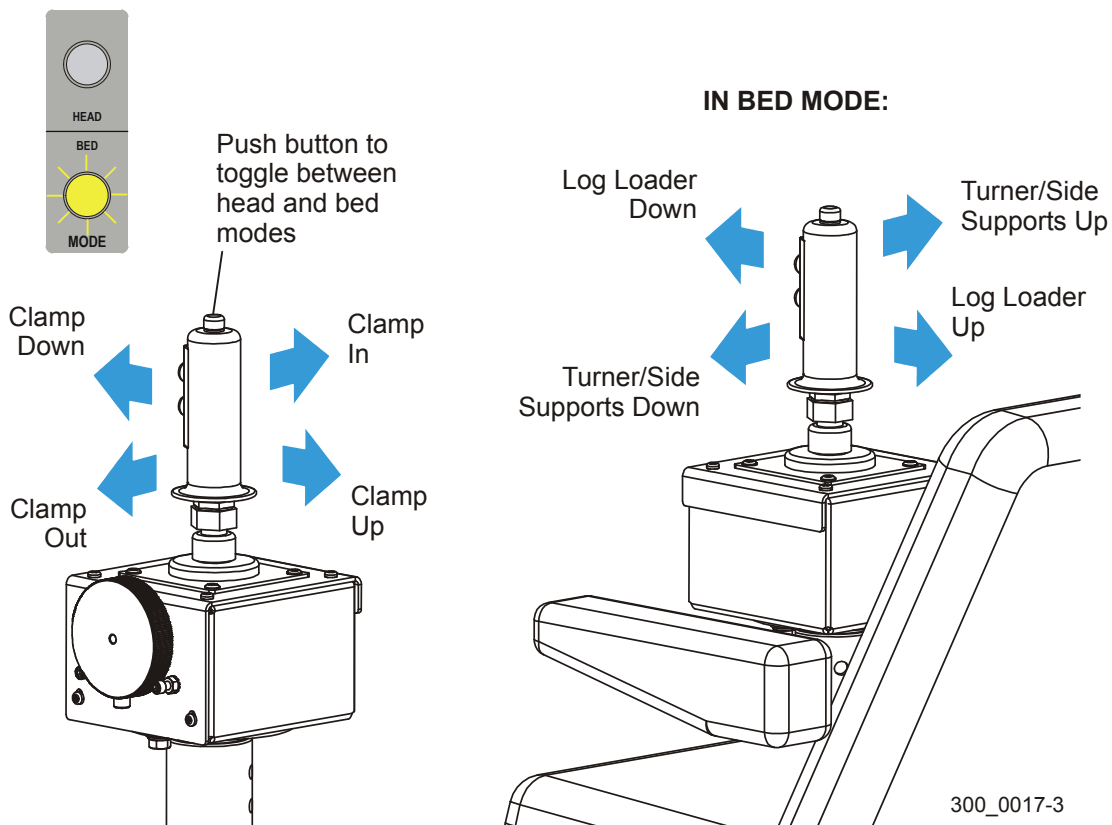


**FIG. 4-4**



**See Figure 4-5.** In BED mode, the joysticks control the log handling functions. Push the top button on the left joystick to change to bed mode. Push the right joystick forward to lower the log loader, pull it back to raise the log loader. Push the right joystick right to raise the log turner and side supports. Push it to the left to lower the turner and side supports.

The left joystick controls the log clamp in BED mode. Push it right to move the clamp in toward the log, left to move the clamp away from the log. Push the left joystick forward to lower the clamp and pull it back to raise the clamp.



**FIG. 4-5**

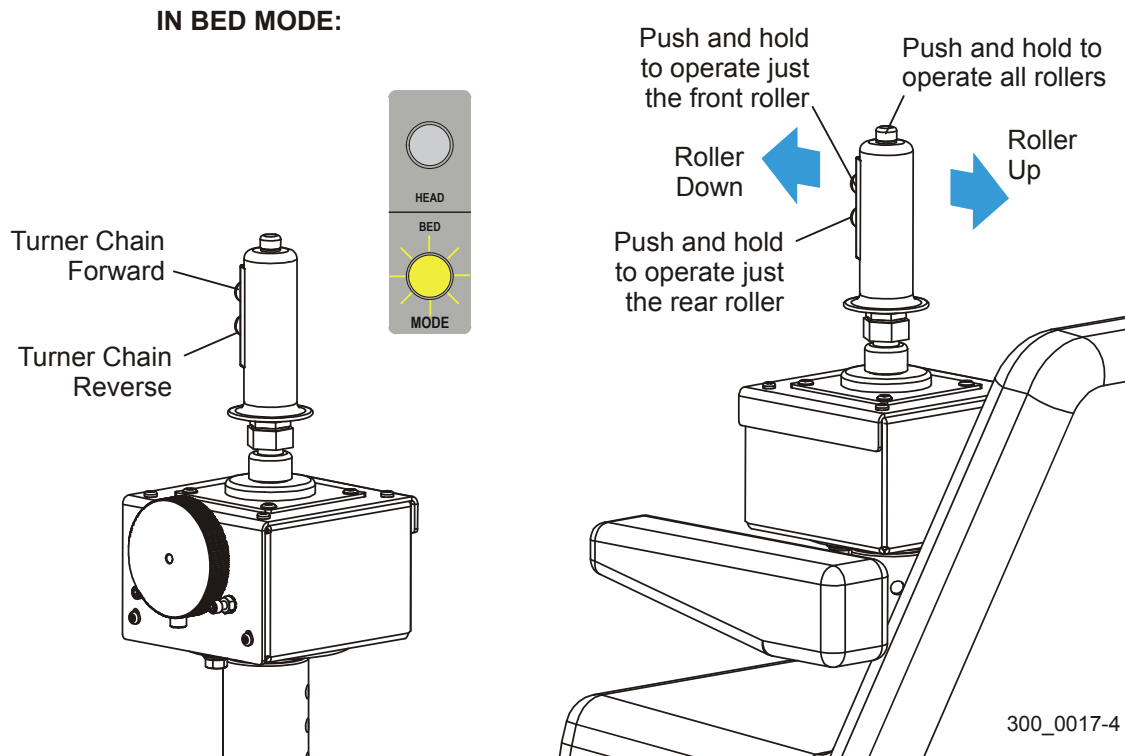
# 4

## Operation

### Joystick Control Overview

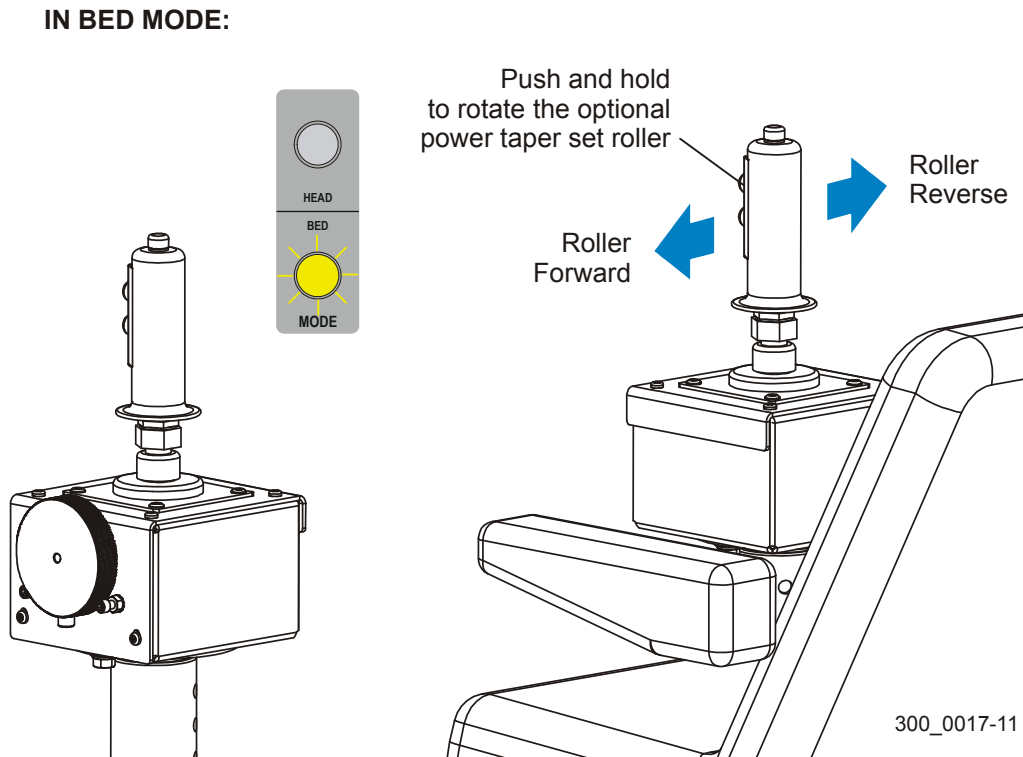
**See Figure 4-6.** Push the top side button on the left joystick to rotate the turner chain forward. Push the bottom side button to reverse the turner chain.

To operate all the bed rollers, push and hold the top button of the right joystick. Push the right joystick forward to lower all the rollers, back to raise all the rollers. To operate just the front or rear roller, push and hold the top or bottom side button to select the front or rear roller. Push the right joystick forward to lower the selected roller, back to raise the selected roller.



**FIG. 4-6**

**See Figure 4-7.** To operate the optional power taper set roller, push and hold the top side button of the right joystick. Push the right joystick to the right to rotate the roller forward, to the left to rotate the roller reverse.



**FIG. 4-7**

## 4.4 Cruise Control

The cruise control feature of the LT300 allows the operator to let the machine choose the maximum cutting speed based on the amount of horsepower required by the blade motor. This feature is especially helpful for new operators who are not familiar with the cutting speeds of the LT300.

Cruise control should only be used when the logs being cut allow for consistent cutting speeds. Avoid using cruise control when sawing various size logs, logs with excessive knots, or logs that are tapered from one end to the other. Cruise control should not be engaged when sawing through the outer (cadmium) layer or rotten portions of wood, frozen timber, or difficult to saw species.

The Max HP and Max PF setting are used together to control the function of the cruise control. These settings are adjusted by moving the selector switch on the front of the control to the desired function and using the up/down arrows to adjust each value.

The Max HP setting represents the target horsepower of the blade motor the cruise control will attempt to maintain. As conditions such as the width of cut, denseness of the wood or condition of the blade change, the cruise control will adjust the power feed speed to maintain the Max HP that you select. To determine where to set the Max HP, observe the horsepower value on the display while making a straight, clean cut controlling the power feed manually. Use this value minus 5 to set the Max HP. You can adjust this value once you make a few cuts using the cruise control.

**Example:** You have trimmed a typical log to a square cant. As you manually use the power feed to saw the cant into boards as fast as you can while maintaining a straight cut, you observe the horsepower value displayed on the control. If the maximum value during the cut is 55, set the cruise control Max HP value to 50 (55 - 5).

The Max HP value can be adjusted to a minimum of 10 and a maximum of 60. The Max HP value cannot be adjusted while cruise control is engaged. Any changes to the Max HP value will not take effect until cruise control is turned off and back on again.

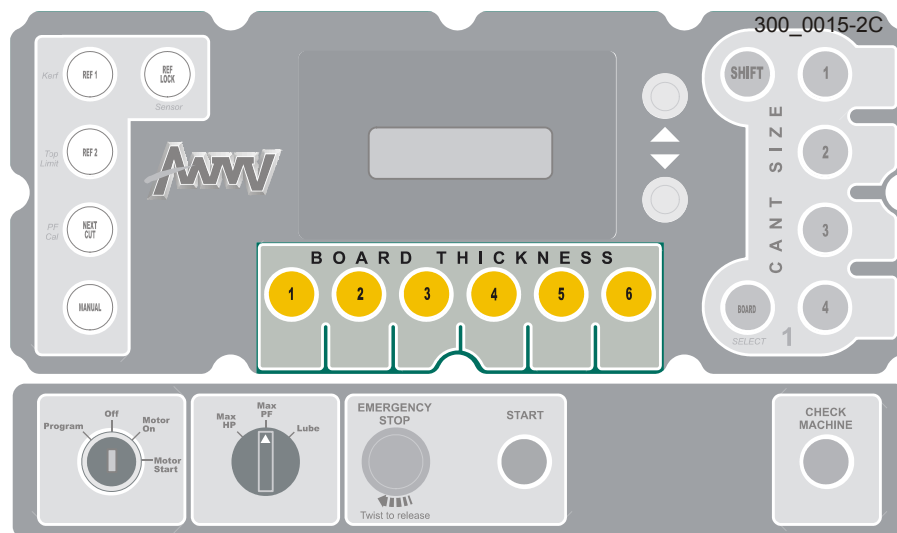
## 4.5 Programming The Control

Several features of the control can be adjusted by the operator.

### 4.5.1 Board Thickness

The six Board Thickness buttons control the distance the saw head drops for each cut. To display the current Board Thickness settings for each button, push the Start button. Push the Cant Size #1 button to enter pattern mode. Push the Board Thickness #1 button. The value for the Board Thickness #1 button will appear on the display (top value of the two shown). Push the other Board Thickness buttons to display their values.

See Figure 4-8.



**FIG. 4-8**

To reprogram any Board Thickness button value, turn the key switch to the Program position. Push the Board Thickness button you wish to reprogram. Use the Up and Down buttons to adjust the value as desired. Push any Board Thickness button to enter the new value. Repeat this procedure for other Board Thickness button values you want to reprogram. Use a dry-erase marker to label each button as a quick reference for the operator.

# 4 Operation

## Cant Size

### 4.5.2 Cant Size

The four Cant Size buttons are used in conjunction with the Board Thickness buttons in pattern mode to control the size of the cant leftover after boards are sawn from the log. To display the current Cant Size settings for each button, push the Start button. Push the Cant Size #1 button to enter pattern mode. Push the Cant Size #1 button again. The value for the Cant Size #1 button will appear on the display (bottom value of the two shown). Push the other Cant Size buttons to display their values.

**Rev. A9.00+:** The SHIFT button allows twelve settings for the four pattern buttons. Push the SHIFT button once. The SHIFT button will illuminate indicating pattern settings 5-8 are active. Push the SHIFT button a second time. The SHIFT button will flash indicating pattern settings 9-12 are active. Push the SHIFT button again to turn off and return to pattern settings 1-4.

See Figure 4-9.

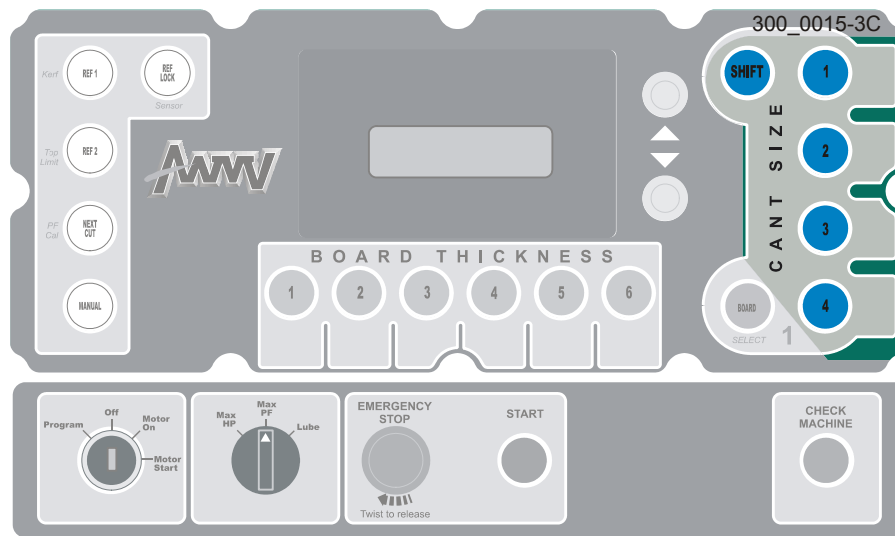


FIG. 4-9

To reprogram any Cant Size button value, turn the key switch to the Program position. Push the Shift/Cant Size button you wish to reprogram. Use the Up and Down buttons to adjust the value as desired. Push any Cant Size button to enter the new value. Repeat this procedure for other Cant Size button values you want to reprogram. Use a dry-erase marker to label each button as a quick reference for the operator.

### 4.5.3 Max HP, Max PF & Lube

These settings are controlled with the selector switch at the front of the control box and can be adjusted during the sawing operation.

See Figure 4-10.

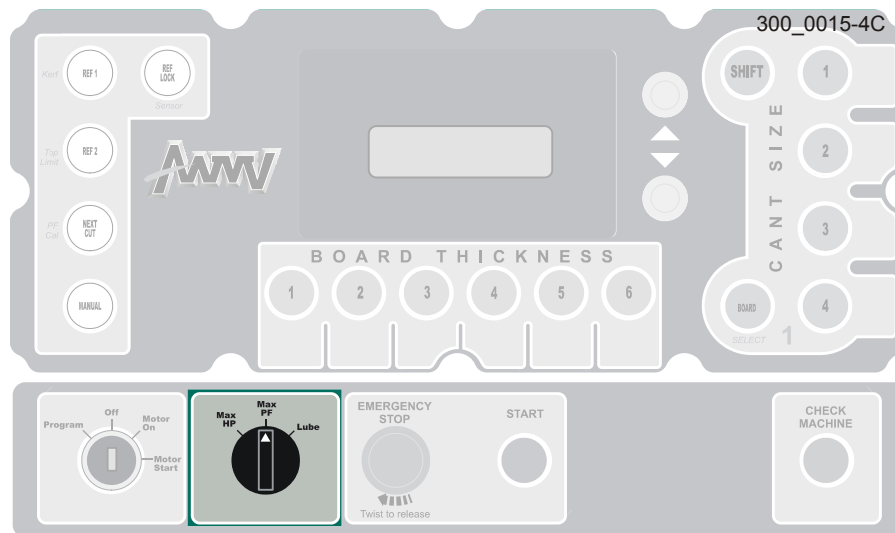


FIG. 4-10

The **Max HP** setting allows the operator to determine the maximum horsepower delivered from the blade motor. To adjust the Max HP value, turn the selector switch to Max HP and use the Up or Down buttons until the desired value is shown on the display.

The **Max PF** setting controls the maximum speed the carriage moves in the cutting direction. To adjust the Max PF value, turn the selector switch to Max PF and use the Up or Down buttons until the desired value is shown on the display.

**NOTE:** The Max HP and Max PF settings are used together to control the function of the cruise control feature. [See Section 4.4](#) for details.

The **Lube** setting controls the amount of lubricant applied to the blade while sawing. Some types of wood require more or less lubrication to prevent sap buildup on the blade. To adjust the Lube setting, turn the selector switch to Lube and use the Up or Down buttons to adjust the setting as desired.

#### **4.5.4**     *Calibration*

The Calibration setting is used to synchronize the control with the transducer sensor so the control displays the blade position accurately. The setting only needs to be changed if the CPU module or transducer sensor is replaced. To view the Calibration setting, turn the key switch to the Program position and push the Ref Lock button. To change the value, use the Up or Down buttons. **NOTE:** The Calibration value is recorded on the transducer sensor housing located at the top of the saw head mast.

#### **4.5.5**     *Upper Saw Head Travel Limit*

This option is available if the area where the sawmill is installed does not have enough height clearance to allow the saw head to travel to the top of the mast. To set the Upper Saw Head Travel Limit, first position the saw head at the height where you want it to automatically stop. Turn the key to the Program position and push the Ref 2 button. Push the Select button to set the limit at the current saw head position.



**4.5.6 Other Settings (Software Versions 4.5+ Only)**

Other settings can be adjusted to fine tune the control to your specific operating conditions. To display the menu for these settings, turn the key switch to the Program position and push the Manual button. Use the Up or Down buttons to scroll through the menu. To adjust any of the menu values, push the Select button and use the Up or Down buttons to adjust the value. Push the Select button to enter the new value and return to the scrolling menu.

The **Autoup Height** setting is used to control the distance the blade moves up after each cut. The default value is 12/32 (3/8"). This setting can be adjusted as necessary.

The **Head Home Position** provides a reference position that can be used to automatically move the saw head to a specific location. The default value is 21". To move the blade to the Head Home Position, push and hold the Manual button and push the Next Cut (or Last Cut) button. This setting can be adjusted if you prefer a different "home" position for the saw head.

The **Max HP Limit** setting allows the operator to determine the maximum horsepower delivered from the blade motor. The default value is 75. This setting can also be adjusted with the selector switch ([See Section 4.5.3](#)).

The **Oiler On Seconds** setting (*Software Versions 4.5 - 5.0 Only*)

The **Oiler Off Minutes** setting (*Software Versions 4.5 - 5.0 Only*)

The **PF A to D** and **PF Range** settings (*Software Versions 5.5+ Only*) show values useful in troubleshooting power feed errors by a qualified technician. These values should not be adjusted by the operator.

The **X64 Drive Selection** setting (*Software Versions 5.5+ Only*) indicates the type of AC drive used in the electrical system and is provided for diagnostic purposes only.

# 4 Operation

## Starting The Machine

### 4.6 Starting The Machine



**DANGER!** Make sure all guards and covers are in place and secured before operating the sawmill. Failure to do so may result in serious injury. Be sure the blade housing and pulley covers are in place and secure.

**DANGER!** Always be sure all persons are out of the path of the blade before starting the motor. Failure to do so will result in serious injury.



**WARNING!** Always wear eye, ear, respiration, and foot protection when operating the sawmill. Failure to do so may result in serious injury.

1. If necessary, release the EMERGENCY STOP button by turning it clockwise until it pops out.

See Figure 4-11.

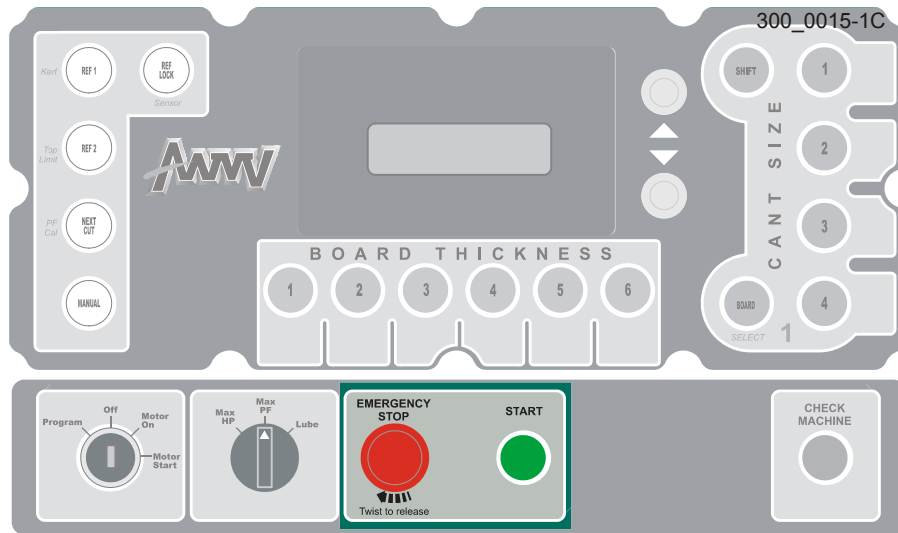





FIG. 4-11


2. To turn the sawmill power on, push the green START button on the control box.

## 4.7 Installing A Blade

 **DANGER!** Always shut off the sawmill and wait until the blade wheels have come to a complete stop before changing the blade. Failure to do so will result in serious injury.

 **WARNING!** Always turn the key switch to OFF and remove the key before changing the blade. Failure to do so may result in serious injury.

 **WARNING!** Always wear gloves and eye protection when handling bandsaw blades. Changing blades is safest when done by one person! Keep all other persons away from area when coiling, carrying or changing a blade. Failure to do so may result in serious injury.

 **WARNING!** DO NOT use blades with stress cracks. Blades with stress cracks can shatter causing bodily injury and/or machine damage.

1. At the operator station control box, turn the key switch to OFF and remove the key.
2. At the saw head distribution box, push the BLADE TENSION button in. This will release the tension on the existing blade (if applicable).
3. Unscrew and pivot the cover lock handles and open the blade housing covers.

See Figure 4-12.

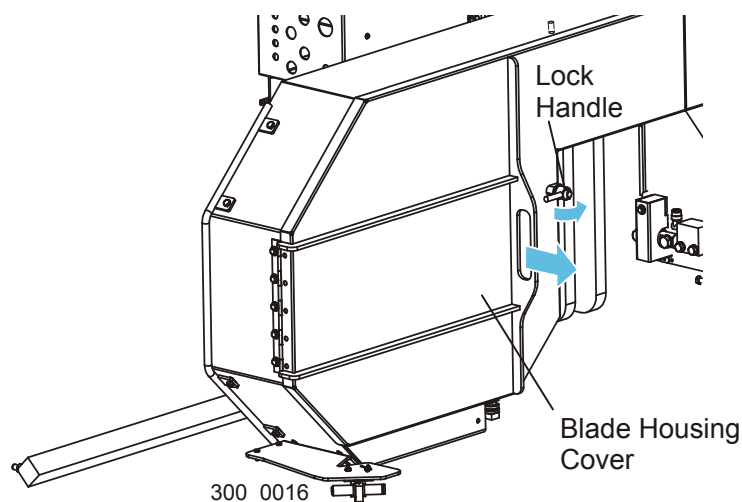


FIG. 4-12

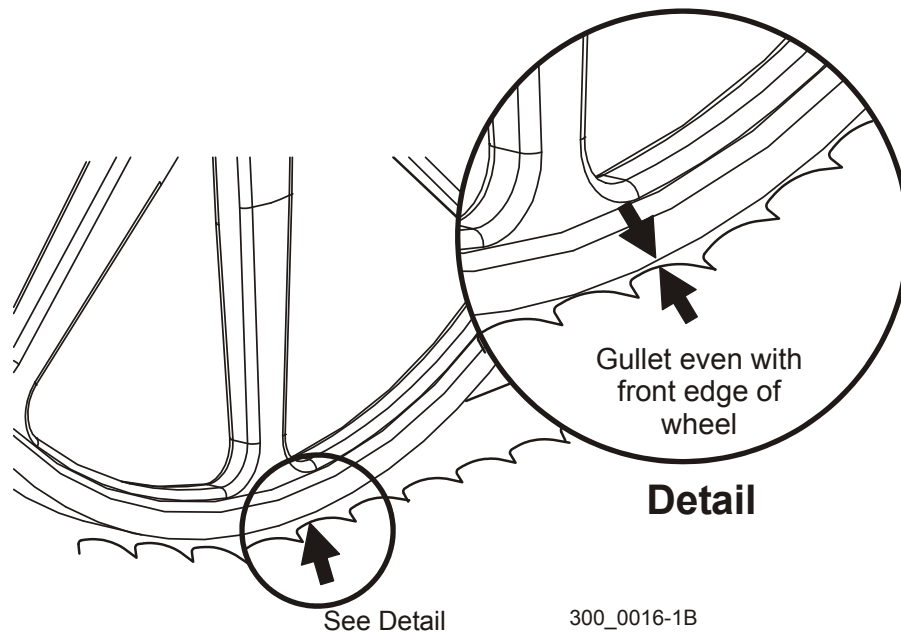
# 4

## Operation

### Installing A Blade

4. Remove the blade if necessary.
5. Install the blade around both blade wheels and between the blade guides. Make sure the teeth are pointing the correct direction. The teeth on the portion of the blade between the blade guides should be pointing toward the motor side of the sawmill.

**See Figure 4-13.** Position the blade on the wheels so the gullet is even with the front edge of the wheel (+1/16", -0).



**FIG. 4-13**

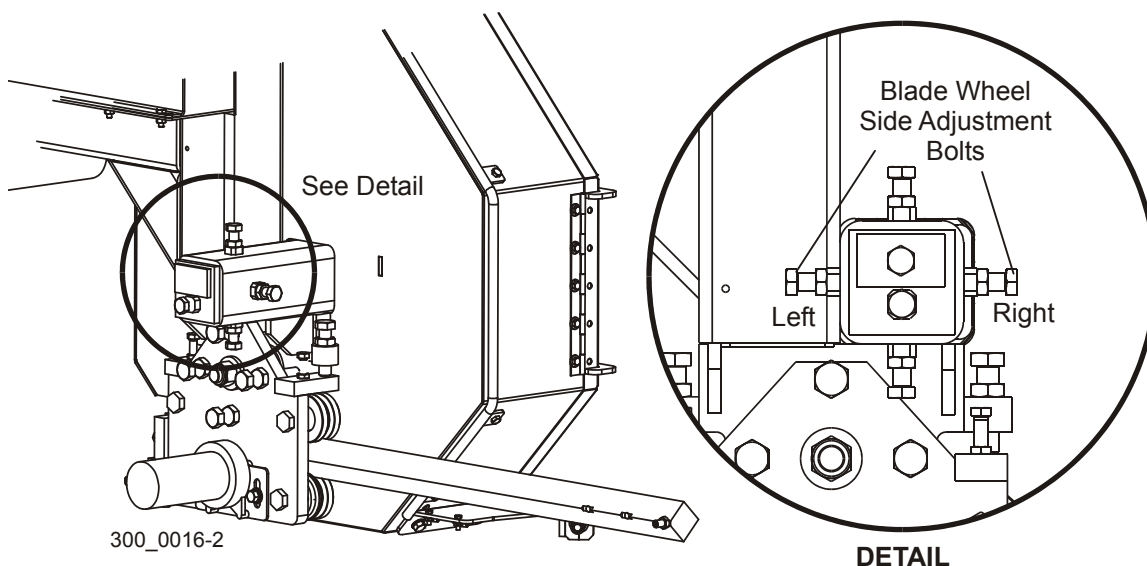
6. Pull the BLADE TENSION button. The TENSION PRESSURE gauge should read 60 psi for 1 1/4" blades, 80 psi for 1 1/2" blades or 100 psi for 1 3/4" blades. To adjust the blade tension pressure, use the TENSION REGULATOR knob. Push the BLADE TENSION button to release the blade tension. Turn the TENSION REGULATOR knob counterclockwise to reduce blade tension, clockwise to increase blade tension. Pull the BLADE TENSION button to retension the blade.
7. Close the blade housing covers, secure with the lock handles and make sure all persons are clear of the saw head.
8. Insert the key and turn the key switch to the MOTOR START position and release, leaving the key switch in the MOTOR ON position. Let the motor spin the blade for a few seconds, turn the key switch to OFF and remove the key.



**WARNING!** Do not spin the blade wheels by hand. Spinning the blade wheels by hand may result in serious injury.

9. Open the blade housing covers and recheck the position of the blade on the blade wheels. Make sure the blade has maintained the proper position on the blade wheels as described above. If adjustment is needed, push the BLADE TENSION button to release the blade tension and adjust the wheel as described below.

**See Figure 4-14.** To adjust the position of the blade on the blade wheels, loosen the jam nuts on the side adjustment bolts located at the end of the blade wheel shaft housing.




**FIG. 4-14**


To move the blade out on the blade wheel, loosen the right bolt and tighten the left bolt. To move the blade in on the blade wheel, loosen the left bolt and tighten the right bolt.


**NOTE:** Slight adjustments of the side bolts on the outer blade wheel are usually all that is necessary to track the blade properly. [See Section 7.2](#) for complete blade wheel alignment instructions.

10. Tighten the side adjustment bolt jam nuts, close the blade housing covers, retension the blade and spin the blade again. Repeat this procedure until the blade tracks on the blade wheels properly.

## 4.8 Loading, Turning And Clamping Logs

 **DANGER!** Keep all persons out of the path of moving equipment and logs when operating sawmill or loading and turning logs. Failure to do so will result in serious injury.

 **CAUTION!** Before loading a log, be sure the cutting head is moved far enough back so the log does not hit it. Failure to do so may result in machine damage.

 **CAUTION!** Be sure the log clamp, turning arm and rollers are adjusted out of the path of the log before loading a log onto the bed. Failure to do so may result in machine damage or cause misalignment.

1. Move the saw head to the rear of the sawmill before loading a log. Push the top button on the left joystick to toggle the MODE function to HEAD, if necessary. Push the top side button on the right joystick to raise the saw head to clear any obstructions and push the right joystick forward to move the saw head to the rear of the sawmill.

See Figure 4-15.

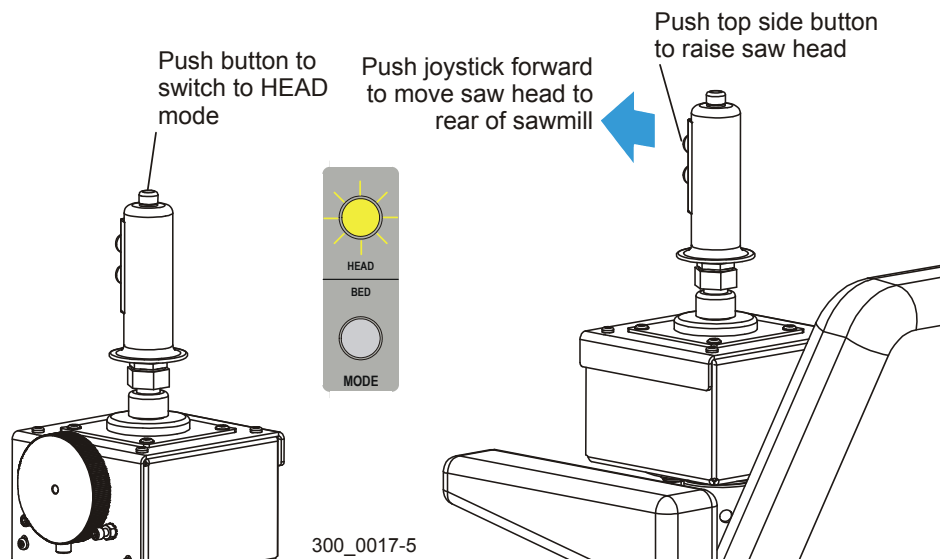


FIG. 4-15

2. Push the top button on the left joystick to toggle the MODE function to BED. Push the right joystick to the right to raise the side supports. Stop when the side supports are fully vertical, before the turner starts up.

See Figure 4-16.

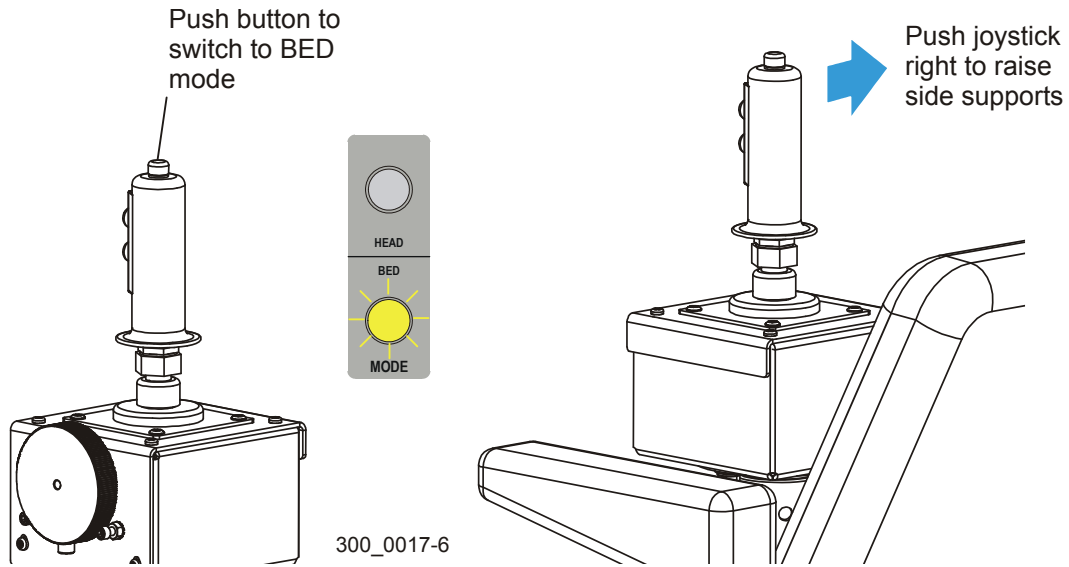


FIG. 4-16

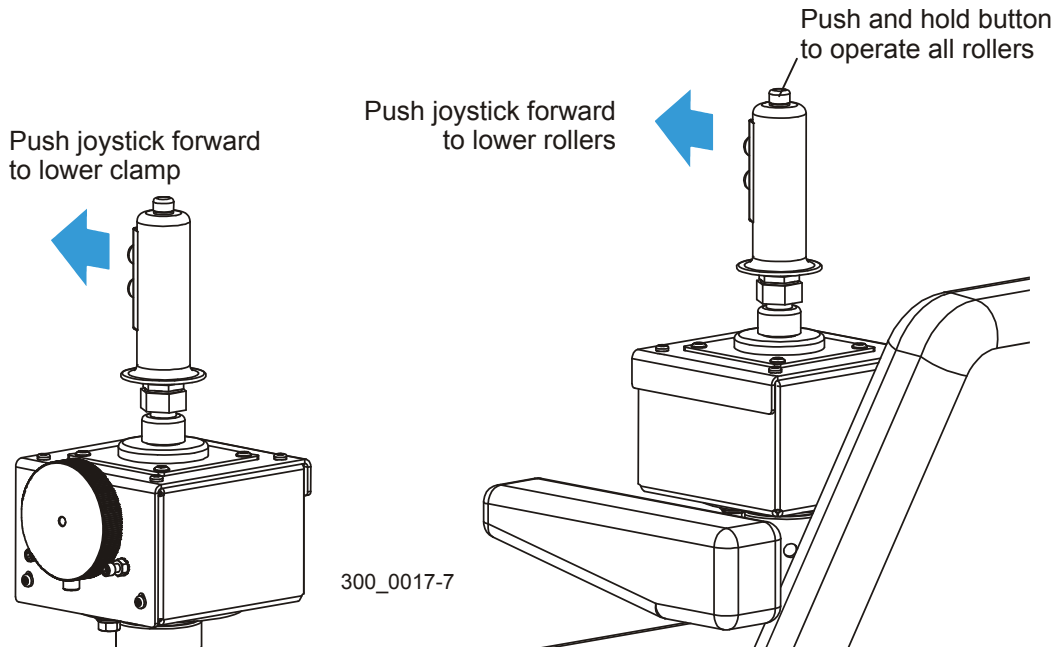
# 4

## Operation

### *Loading, Turning And Clamping Logs*

3. If necessary, lower the clamp and rollers so they are below bed level. Push the left joystick forward to lower the clamp. Push and hold the top button on the right joystick. Push the right joystick forward to lower the rollers.

See Figure 4-17.



**FIG. 4-17**



4. Push the right joystick forward to lower the log loader, if necessary.
5. Use cant hooks or loading equipment to move the log to the foot of the loading arms. Roll the log onto the loader so that it is approximately centered with the sawmill bed. The log turner will operate much easier if the log is centered on the sawmill bed.

See Figure 4-18.

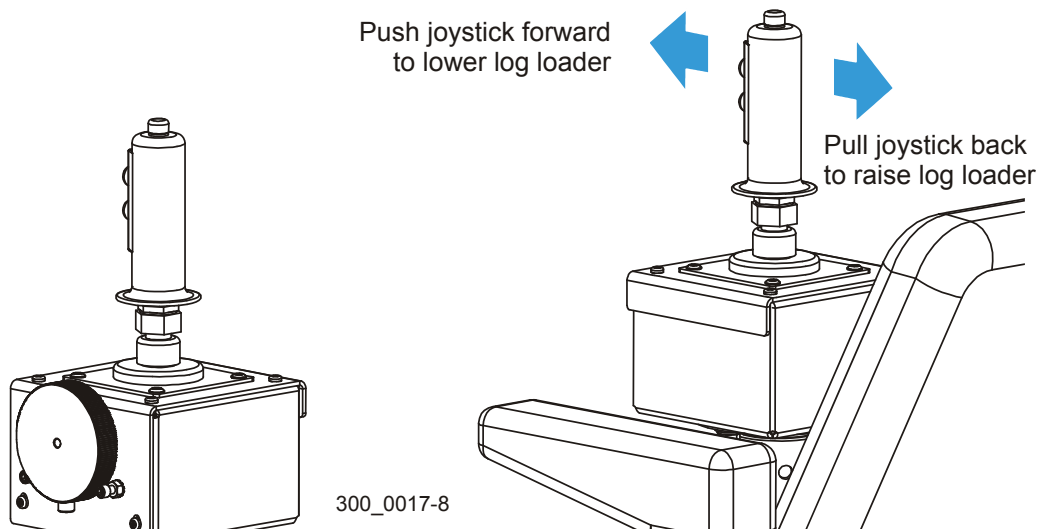


FIG. 4-18

6. Pull the right joystick back to raise the log loader. Raise the loader until the log rolls onto the mill bed.

**! DANGER!** Keep all persons out of the path of moving equipment and logs when operating sawmill or loading and turning logs. Failure to do so will result in serious injury.

7. Push the right joystick forward to lower the loading arm. Leave the loading arm about halfway up while squaring the log. This will stop the log from rolling off the side of the sawmill.

**! WARNING!** Always leave loading arm halfway up while log is on sawmill bed. Failure to do so may result in serious injury or death.

**NOTE:** Logs also may be loaded onto the mill with a tractor or other equipment specifically designed for that purpose.

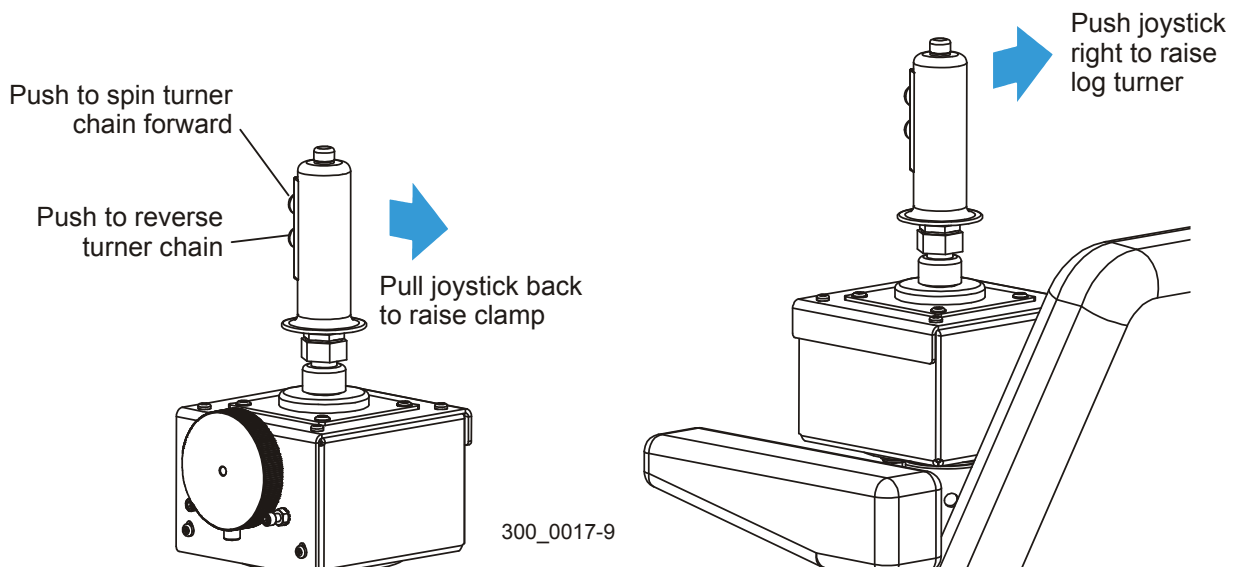
# 4

## Operation

### *Loading, Turning And Clamping Logs*

8. Pull the left joystick back to raise the clamp to prevent the log from rolling off the bed.
9. Push the right joystick to the right to raise the log turner until it contacts the log. Hold the joystick to the right so the turner maintains contact with the log. Push the top and bottom side buttons on the left joystick to rotate the turner chain until the log is positioned as desired for the first cut.

See Figure 4-19.

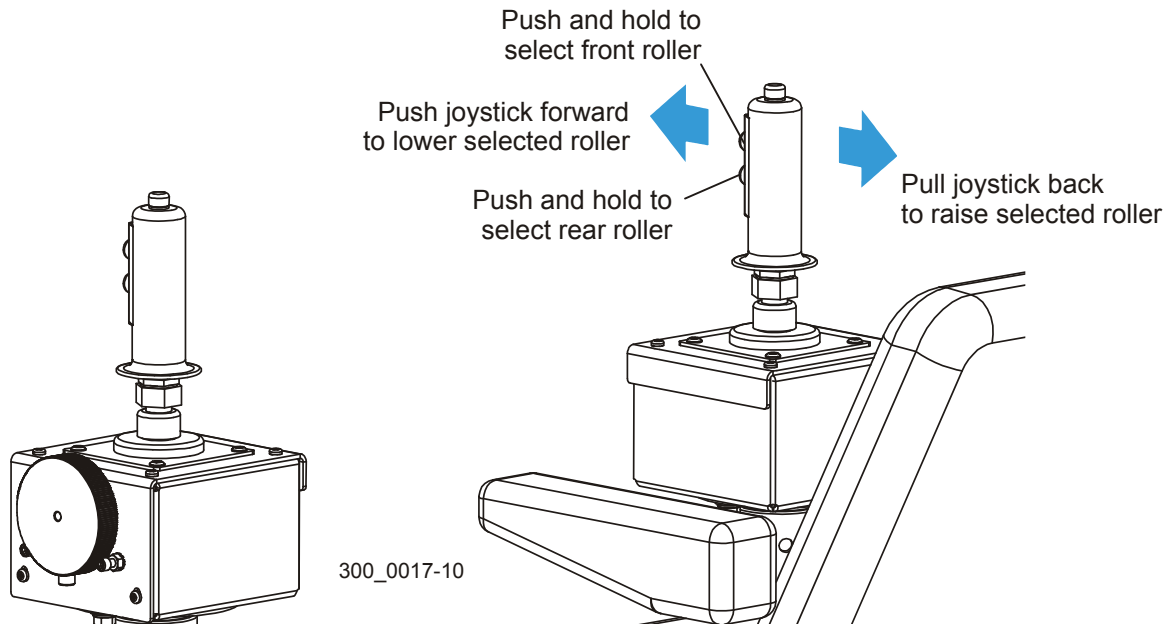


**FIG. 4-19**

10. Push the left joystick to the right to move the clamp toward the log. Before the clamp contacts the log, push or pull the left joystick to raise or lower the clamp as desired. Push the right joystick to the left to lower the turner. Continue until the side supports are lowered to the desired position.

11. Use the front or rear roller to raise the small end of a tapered log until the heart of the log is parallel to the bed. Push and hold the top side button on the right joystick to select the front roller, or the bottom side button to select the rear roller. Push the right joystick forward to raise the selected roller, back to lower the selected roller.

See Figure 4-20.

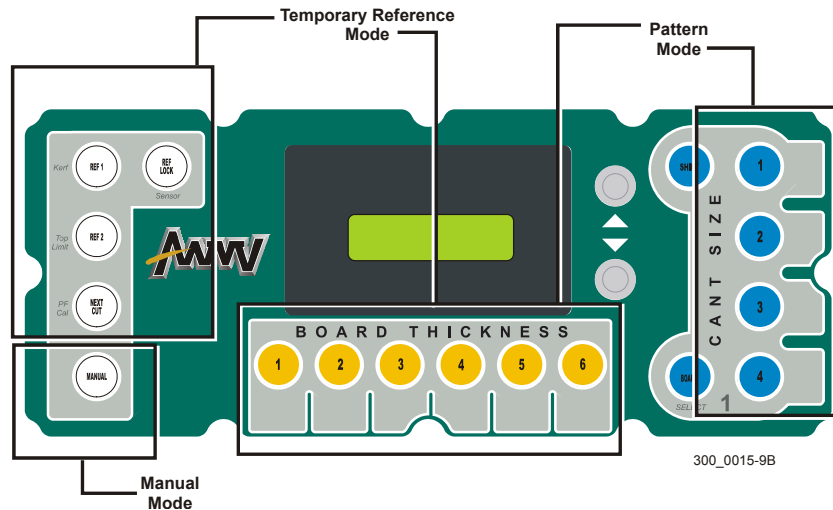


**FIG. 4-20**

12. Push the left joystick to the right until the log is clamped firmly against the side supports.
13. Push the top button on the left joystick to switch to HEAD mode to begin sawing the log.

## 4.9 Networks Overview

See Figure 4-21. There are three sawing methods that can be used to saw logs:



**FIG. 4-21**



**MANUAL mode:** the joystick controls will move the saw head up or down to any position until the joystick control is released.



**TEMPORARY REFERENCE mode:** the control references a temporary position of the blade (not the bed) and automatically moves the blade the distance determined by the selected BOARD THICKNESS button. Mostly used when sawing for grade where the outer perimeter of the log contains the highest-quality boards.



**PATTERN mode:** the control references the position of the blade from the bed rails determined by the selected CANT SIZE button. The control will automatically move the blade the distance determined by selected BOARD THICKNESS button starting at the distance from the bed determined by the selected CANT SIZE button. Typically used when dimensional sawing or finishing a hardwood log to a finish sized cant.

**4.9.1 Temporary Reference Mode**

**See Figure 4-22.** Temporary Reference Mode utilizes the group of white buttons at the left of the control. This mode allows the operator to temporarily set any position of the blade (not the bed) as a reference for subsequent cuts. Temporary Reference Mode is best used when sawing for grade where the outer perimeter of the log contains the highest-quality boards.



**FIG. 4-22**

Use the white buttons in combination with the yellow BOARD THICKNESS buttons when sawing in Temporary Reference Mode:

1. When you first turn on the machine, the control defaults to Manual Mode (the white MANUAL button will be on).
2. With a new log loaded and clamped in position on the bed, push the REF 1 button to enter Temporary Reference Mode. The MANUAL light will go out. The saw head will still operate as if in Manual Mode until the reference position is locked by using the REF LOCK button as described later.
3. When REF 1 is activated, one of the yellow BOARD THICKNESS buttons will illuminate. By default, the last thickness used in REF 1 will be selected. Choose another BOARD THICKNESS button as desired. [See Section 4.5.1](#) for instructions to program the BOARD THICKNESS buttons.
4. Raise or lower the saw head using the joystick Up/Down buttons until the blade is positioned where you want to make the first cut.



## 4

## Operation

## Temporary Reference Mode

5. Push the REF LOCK and NEXT CUT (or LAST CUT before 3/04) buttons.

**SHORTCUT:** Press the bottom-left joystick button to enable REF LOCK and NEXT CUT (or LAST CUT) simultaneously. After the reference is locked, the joystick button will toggle NEXT CUT (or LAST CUT) on and off.

**See Figure 4-23.** With the position of the blade now stored and locked as REF 1, when you push the Up or Down joystick button, networks will move the blade up or down the distance determined by the selected BOARD THICKNESS button. With NEXT CUT (or LAST CUT) enabled, Networks will automatically position for the next cut below the last set position of the blade.

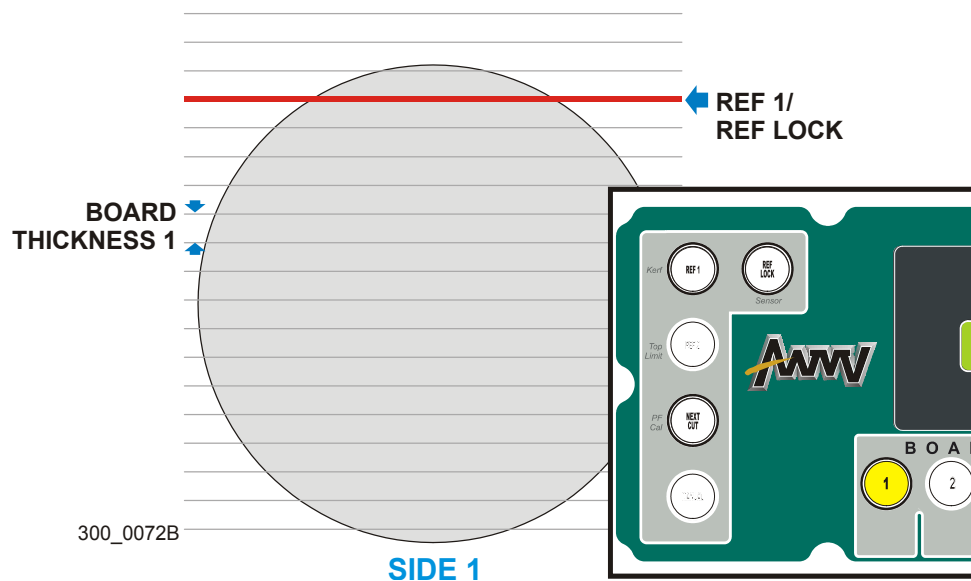


FIG. 4-23

6. After making the first cut, raise and return the saw head. There are two methods of raising the saw head that can be used when sawing in Temporary Reference Mode:

**Auto Bump-up:** Use the top side button on the left joystick to slightly raise the blade and drag the board/slab off when you return the saw head. Auto Bump-up does not affect the stored position of the blade during the last cut.

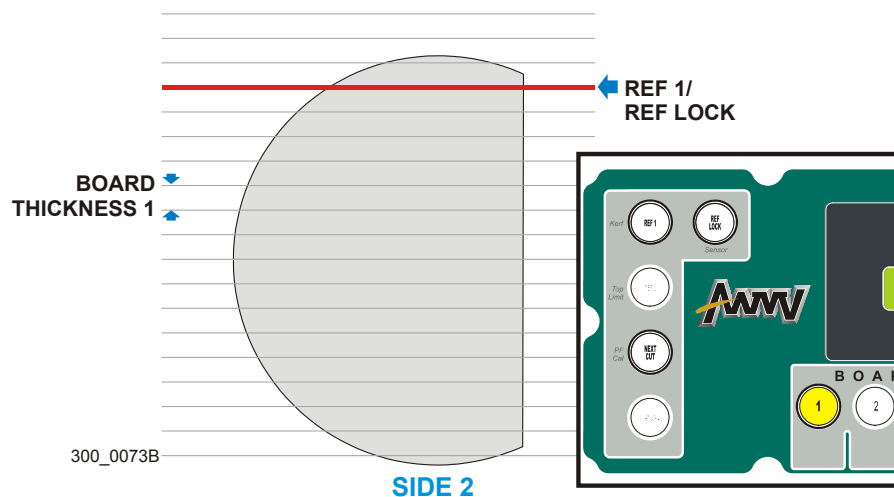
**Saw Head Up:** If the slab is too small to drag back, use the top side button on the right joystick to raise the blade over the slab. Hold the button until the blade is above the slab then quickly press the button a second time. This will abort the Networks control before it reaches the next programmed target, preventing it from replacing the stored position of the blade during the last cut.

7. Return the saw head. Push the joystick Down button momentarily and setworks will automatically position the blade for the next cut.
8. Make cuts as desired until you are ready to turn the log.
9. Return the saw head and push the REF LOCK button to disable the lock.

**NOTE:** Since the log was resting on a round, REF 1 is a throw-away reference. You don't need to keep the REF 1 value until the log is resting on a flat.

10. Turn the log. Raise or lower the saw head until the blade is positioned as desired. Enable REF LOCK and NEXT CUT.

**See Figure 4-24.** With the position of the blade now stored and locked as REF 1, when you push the Up or Down joystick button, setworks will move the blade up or down the distance determined by the selected BOARD THICKNESS button. With NEXT CUT enabled, Setworks will automatically position for the next cut below the last set position of the blade.



**FIG. 4-24**

11. Make the cut and return the saw head. Push the joystick Down button momentarily and setworks will automatically position the blade for the next cut.
12. Make cuts as desired until you are ready to turn the log.
13. Return the saw head and push the REF LOCK button to disable the lock.
14. Turn the log. Raise or lower the saw head until the blade is positioned as desired. Enable REF LOCK and NEXT CUT.

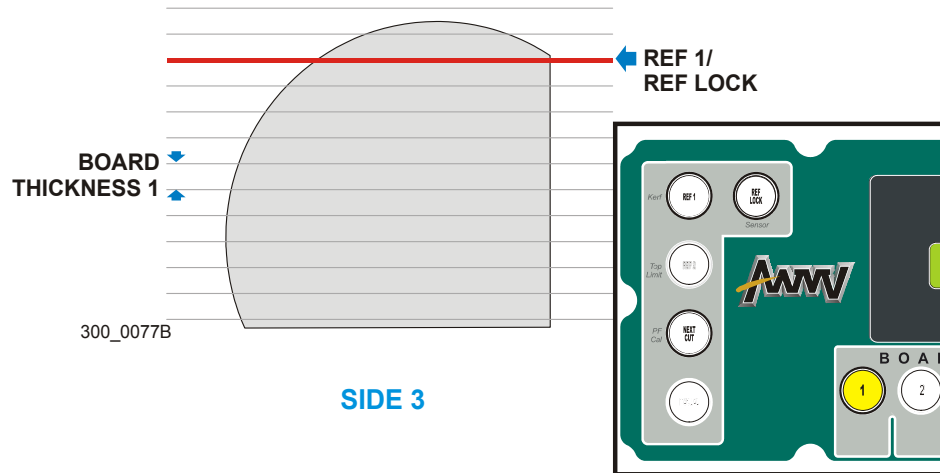


## 4

## Operation

## Temporary Reference Mode

See **Figure 4-25**. With the position of the blade now stored and locked as REF 1, when you push the Up or Down joystick button, networks will move the blade up or down the distance determined by the selected BOARD THICKNESS button. With NEXT CUT enabled, Setworks will automatically position for the next cut below the last set position of the blade. Since the log was resting on a flat, the REF 1 value should be kept and REF 2 used for the next side of the log.



**FIG. 4-25**

15. Make the cut and return the saw head. Push the joystick Down button momentarily and networks will automatically position the blade for the next cut.
16. Make cuts as desired until you are ready to turn the log.
17. Return the saw head. Now that three sides of the log are flat, you can retain REF 1 to cut sides 1 and 3. DO NOT push the REF LOCK button or you will lose the REF 1 setting. Push the REF 2 button to leave REF 1 and enable REF 2. REF 1 dimensions will remain 'locked' until you unlock it by pushing REF LOCK or MANUAL buttons.
18. Turn the log. Raise or lower the saw head until the blade is positioned as desired. Enable REF LOCK and NEXT CUT.





**See Figure 4-26.** With the position of the blade now stored and locked as REF 2, when you push the Up or Down joystick button, setworks will move the blade up or down the distance determined by the selected BOARD THICKNESS button. With NEXT CUT enabled, Setworks will automatically position for the next cut below the last set position of the blade.



**FIG. 4-26**

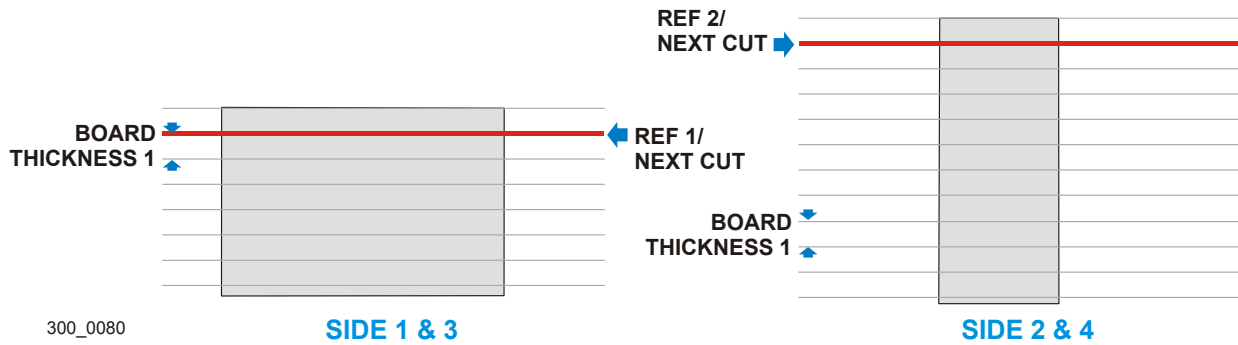
19. Make the cut and return the saw head. Push the joystick Down button momentarily and setworks will automatically position the blade for the next cut.
20. Make cuts as desired until you are ready to turn the log. Now that all four sides of the log are flat, you can simply toggle between REF 1 and REF 2 as you turn the log.
21. Return the saw head and turn the log. Push the REF 1 button and push the joystick Down button momentarily. Setworks will position the blade for the next cut referenced from the last cut made in REF 1.

**NOTE:** With NEXT CUT (or LAST CUT) enabled, the saw head will move to the next sawing position if you press the UP or DOWN joystick button. If the blade needs to move up to reach the NEXT CUT (or LAST CUT), even if you push the DOWN button, the saw head will move up.

## 4 Operation

### Temporary Reference Mode

See **Figure 4-27**. When you push the Up or Down joystick button, networks will move the blade up or down the distance determined by the selected BOARD THICKNESS button.



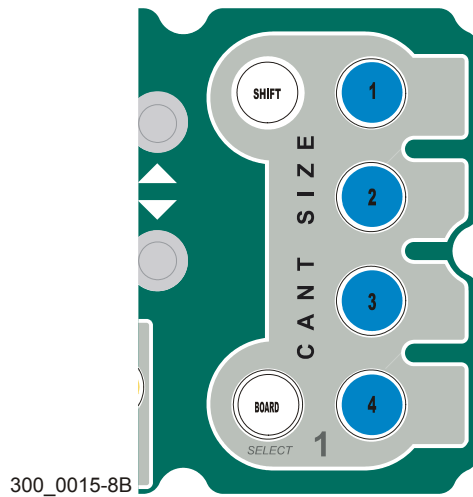
**FIG. 4-27**

22. Continue turning and sawing the log, using REF 1, REF 2 and NEXT CUT. You can switch BOARD THICKNESS buttons or change to Pattern Mode ([See Section 4.9.2](#)) at any time.

**4.9.2 Pattern Mode**

**See Figure 4-28.** Pattern Mode utilizes the blue CANT SIZE buttons at the right of the control. This mode allows the operator to position the blade referenced from the bed rails. Pattern Mode is best used when sawing dimensional lumber or finishing a cant to size when grade sawing.

**Rev. A9.00+:** The SHIFT button allows twelve settings for the four pattern buttons. Push the SHIFT button once. The SHIFT button will illuminate indicating pattern settings 5-8 are active. Push the SHIFT button a second time. The SHIFT button will flash indicating pattern settings 9-12 are active. Push the SHIFT button again to turn off and return to pattern settings 1-4.

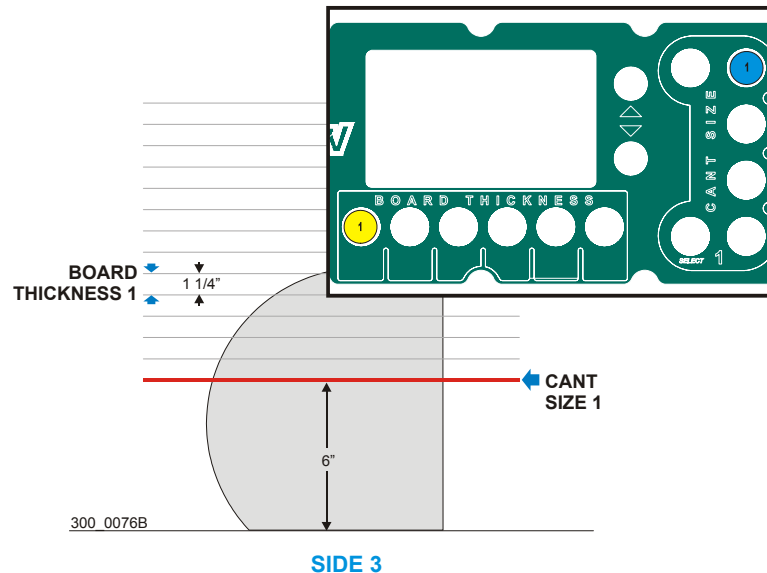


**FIG. 4-28**

Use the blue buttons in combination with the yellow BOARD THICKNESS buttons when sawing in Pattern Mode:

1. Use Temporary Reference Mode until at least two adjacent sides of the log are flat ([See Section 4.9.1](#)).
2. With the log resting on a flat, push the desired CANT SIZE button. Networks is now in Pattern Mode. [See Section 4.5.2](#) for instructions to program the CANT SIZE buttons.
3. When a CANT SIZE button is activated, one of the yellow BOARD THICKNESS buttons will illuminate. By default, the last thickness used with the selected CANT SIZE setting will be selected. Choose another BOARD THICKNESS button as desired. [See Section 4.5.1](#) for instructions to program the BOARD THICKNESS buttons.
4. In Pattern Mode, networks calculates the blade position in increments defined by the BOARD THICKNESS setting, starting at the position determined by the CANT SIZE setting.

See **Figure 4-29**. With CANT SIZE button #1 programmed for 6" and BOARD THICKNESS button #1 programmed for 1 1/4", setworks calculates the blade position as shown.



**FIG. 4-29**

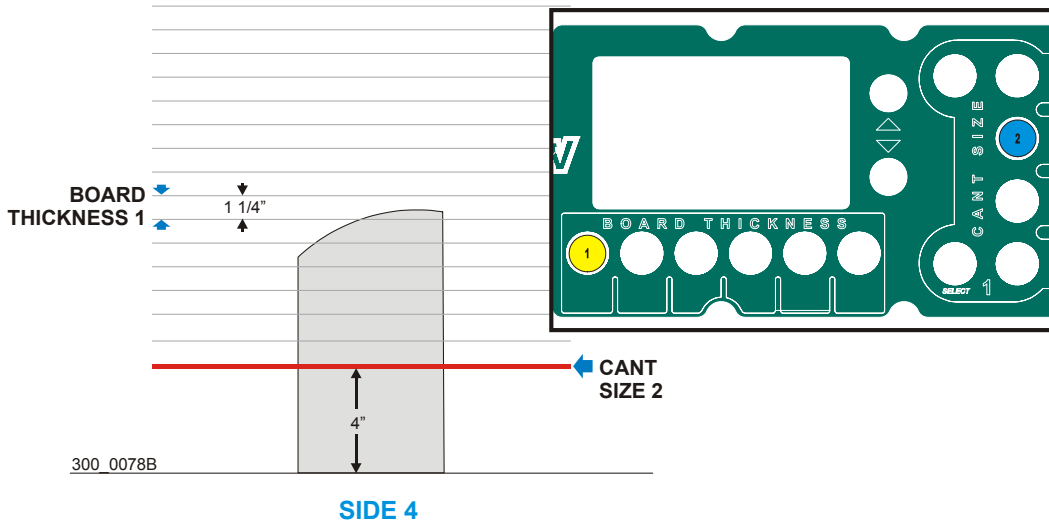
5. Press the Up or Down joystick button momentarily to position the blade for the first cut. Push the NEXT CUT button.
6. After making the first cut, raise and return the saw head. There are two methods of raising the saw head that can be used when sawing in Pattern Mode:

**Auto Bump-up:** Use the top side button on the left joystick to slightly raise the blade and drag the board/slab off when you return the saw head. Auto Bump-up does not affect the stored position of the blade during the last cut.

**Saw Head Up:** If the slab is too small to drag back, use the top side button on the right joystick to raise the blade over the slab. Hold the button until the blade is above the slab then quickly press the button a second time. This will abort the Setworks control before it reaches the next programmed target, preventing it from replacing the stored position of the blade during the last cut.

7. Return the saw head. Push the joystick Down button momentarily and setworks will automatically position the blade for the next cut.
8. Make cuts as desired until you are ready to turn the log.
9. You can choose a different CANT SIZE setting for the second side of the log.

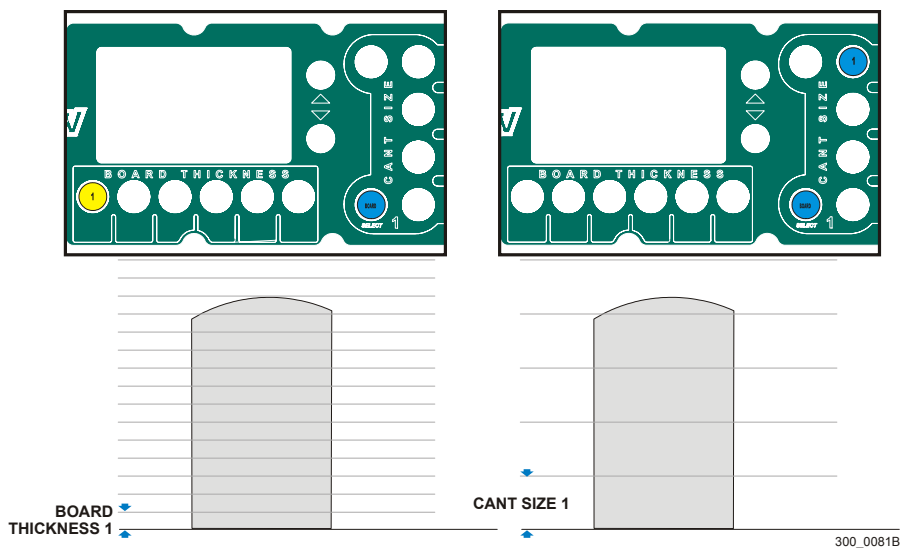
See **Figure 4-30**. With CANT SIZE button #2 programmed for 4" and BOARD THICKNESS button #1 programmed for 1 1/4", setworks calculates the blade position as shown.



**FIG. 4-30**

Use the CANT SIZE and BOARD THICKNESS buttons in combination to continue sawing the rest of the log. In this example, you are left with a 4x6 cant.

See **Figure 4-31**. The BOARD button provides ten pre-programmed board thicknesses calculated from the bed rails. With the BOARD button enabled, Setworks will calculate the blade position using any one of the BOARD THICKNESS or CANT SIZE buttons.



**FIG. 4-31**

## 4.10 Sawing Logs



**DANGER!** Keep all persons out of the path of moving equipment and logs when operating sawmill or loading and turning logs. Failure to do so will result in serious injury.

The following is a general procedure for sawing a log. See the previous sections of this manual for details concerning the operations listed.

### **4.10.1 Prepare the sawmill for loading a log**

1. Push the START button on the control panel to turn the machine on.
2. Push the MODE button (top-left joystick) to enter HEAD MODE.
3. Push the right joystick forward to move the saw carriage to the rear of the machine. Be sure the saw head is clear of the log to be loaded.
4. Rotate the feed rate dial all the way away from you to set the feed to zero.
5. Push the MANUAL and NEXT CUT (or LAST CUT) buttons simultaneously to move the blade to the “home” position.
6. Push the MODE button to enter BED mode.
7. Push the right joystick to the left to raise the side supports. Release the joystick before the turner rises above the bed rails.
8. Push the left joystick to the left until the clamp is all the way out. Push the left joystick forward to lower the clamp below the bed rails.
9. Push and hold the top-right joystick button and push the right joystick forward to lower all toe rollers below the bed rails.

### **4.10.2 Load the log**

1. If using the standard log loader, push the right joystick forward to lower the loader if necessary. Roll a log onto the loader. Pull the right joystick back to raise the loader until the log rolls onto the bed rails.

If using the optional log infeed deck, push the right joystick forward to lower the log deck until the log rolls onto the bed rails.

2. Pull the left joystick back to raise the clamp to prevent the log from rolling off the bed rails.
3. If using the standard log loader, push the right joystick forward to lower the loader halfway

down.



**WARNING!** Always leave loading arm halfway up while log is on sawmill bed. Failure to do so may result in serious injury or death.

If using the optional log infeed deck, pull the right joystick back to raise the log deck all the way up.

#### **4.10.3 Turn the log**

1. Push the right joystick to the right to raise the log turner until the chain engages the log. Push the left joystick side buttons to rotate the log as desired.
2. Push the right joystick to the left to lower the log turner. When the turner is all the way down, the side supports will start to go down.
3. Release the joystick when the side supports are positioned as desired. Be sure the side supports are positioned below the path of the blade.

#### **4.10.4 Clamp the log**

1. Push the left joystick forward to lower the clamp. Be sure the clamp is positioned below the path of the blade.
2. Push the left joystick to the right to move the clamp toward the log.
3. Release the left joystick when the log is clamped securely against the side supports. Double-check the clamp and side supports are positioned below the path of the blade.

#### **4.10.5 Level the log**

1. If the log is tapered on one end, use the toe rollers to lift the small end up. Move the clamp out slightly.
2. To raise the front toe rollers, press and hold the top-right joystick button and pull the right joystick back.

To raise the rear toe roller, press and hold the bottom-right joystick button and pull the right joystick back.

3. Reclamp the log.

#### **4.10.6 Saw the log**

1. Push the top-left joystick button to enter HEAD mode.

**4****Operation***Saw the log*

---

2. Turn the key switch to MOTOR START and release.
3. With the feed rate dial adjusted all the way down, pull the right joystick back. Slowly rotate the feed rate dial toward you until the blade is close to the end of the log. Release the joystick to stop the saw head. Rotate the feed rate dial away from you to return the feed rate to zero.
4. Push the top and bottom buttons on the right joystick to raise or lower the saw head until the blade is positioned for the first cut. Use the laser sight to help you determine the best location for the cut. The laser beam indicates the path of the blade down the entire log.
5. Push the right joystick left or right to move the outer blade guide close to the log.
6. Select the networks mode and push the bottom-left joystick to enable REF LOCK and/or NEXT CUT (or LAST CUT).
7. Pull the right joystick back and slowly turn the feed rate dial toward you. When the blade is completely in the log, turn the feed rate dial toward you until the desired cutting speed is reached.
8. As you make the cut, watch the position of the outer blade guide and adjust in or out as necessary.
9. When the blade exits the log, increase the feed rate until the board return fingers drop down at the end of the log. Release the right joystick and turn the feed rate dial all the way down.
10. Push the top-left joystick button to raise the blade slightly.
11. Push the right joystick forward to return the saw head and remove the board/slab. Hold the top-right joystick button down as you return the saw head to blowoff sawdust from the last cut so you clearly see the grade of the wood.
12. Push the bottom-right joystick to lower the blade for the next cut or turn the log.



## SECTION 5 MAINTENANCE

This section lists the maintenance procedures that need to be performed.

See the [Maintenance Log](#) located after this section for a complete list of maintenance procedures and intervals. Keep track of machine maintenance by filling in the machine hours and the date you perform each procedure.



**This symbol** identifies the interval (hours of operation) at which each maintenance procedure should be performed. Procedures that should be performed “as required” are indicated by “A/R”.

Be sure to refer to option and engine manuals for other maintenance procedures.

### 5.1 Blade Guides (Standard Block/Roller Guides)

**NOTE:** Block/Roller Guides are standard on the LT300 (Rev. A8.00 and later).

1. Check the rollers for performance and wear every blade change. Make sure the rollers are clean and spinning freely. If not, replace them. Replace any rollers which have worn smooth or have become cone shaped.
2. Inspect the blocks at every blade change for damage or wear. If the block housing is bent or damaged, replace the block assembly. Also, replace the block assemblies before the blocks are worn to a point the blade may contact the block housing.
3. Check the guide blocks are properly spaced from the blade every 25 hours of operation. Use the provided shim or a feeler gauge to check the blocks are adjusted .008” - .010” from the blade.



As the blocks wear, the front inside corner will wear more than the body of the block. When the corner wears far enough, sawing performance will be affected even if the body of the block is adjusted properly to the blade. At this point, the block should be replaced. If you have access to the appropriate equipment, you can grind or mill the blocks to a new flat surface and reuse them. It is recommended you develop a routine schedule for replacing the blade guide blocks based on your sawing conditions and experience.

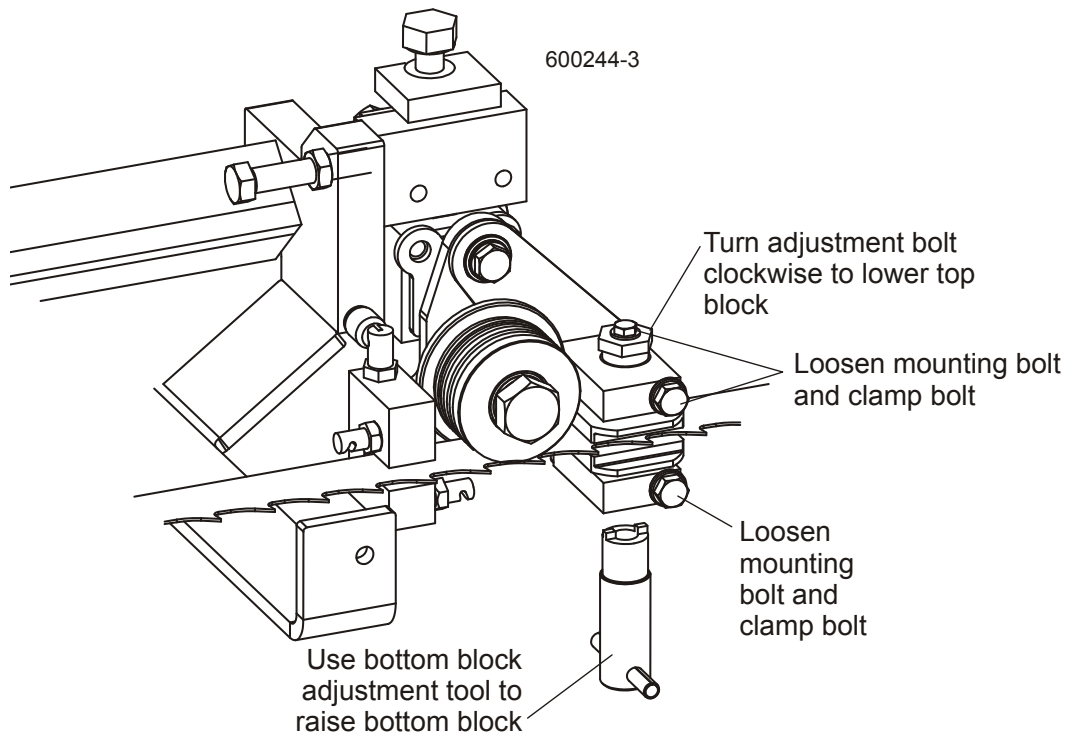
**See Figure 5-1.**

To adjust the top block up, loosen the clamp bolt and mounting bolt. Turn the adjustment bolt counterclockwise. Retighten the mounting bolt and clamp bolt.

To adjust the bottom block up, loosen the clamp bolt and mounting bolt. Use the provided adjustment tool to turn the adjustment screw clockwise. Retighten the mounting bolt and clamp bolt.



**IMPORTANT!** The blocks should be parallel to the blade.  
[See Section 7.2.5](#) for instructions about checking and adjusting the assembly level with the blade.



**FIG. 5-1 LT300 REV. B3.01 AND WM3000/WM3500 REV. B4.01 - B5.01**

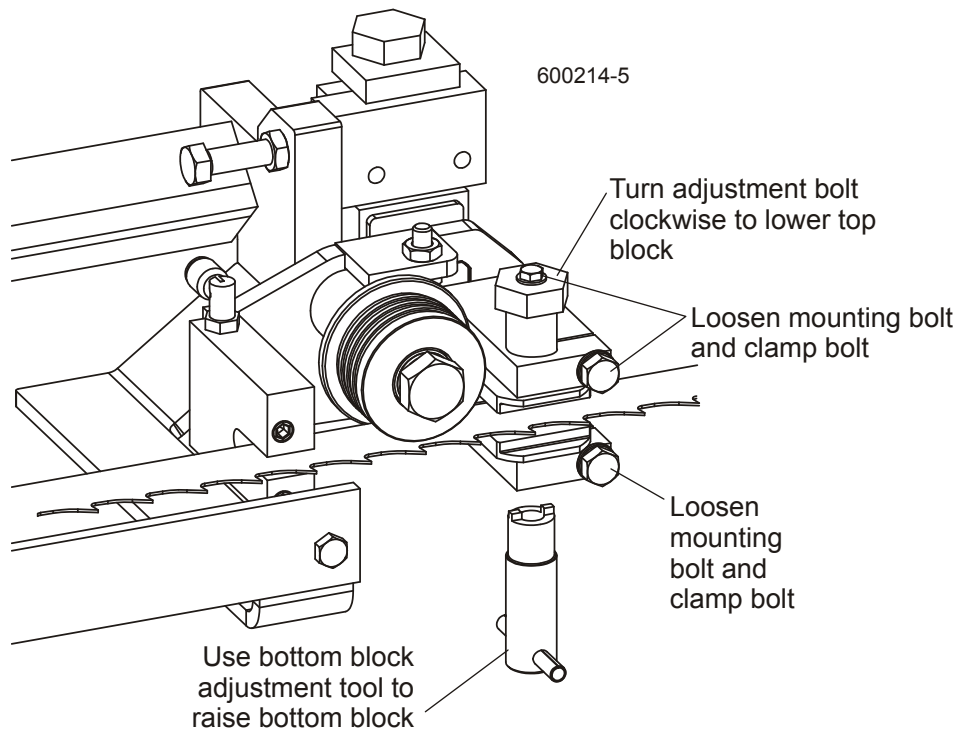


FIG. 5-1 A9.04 - B3.00

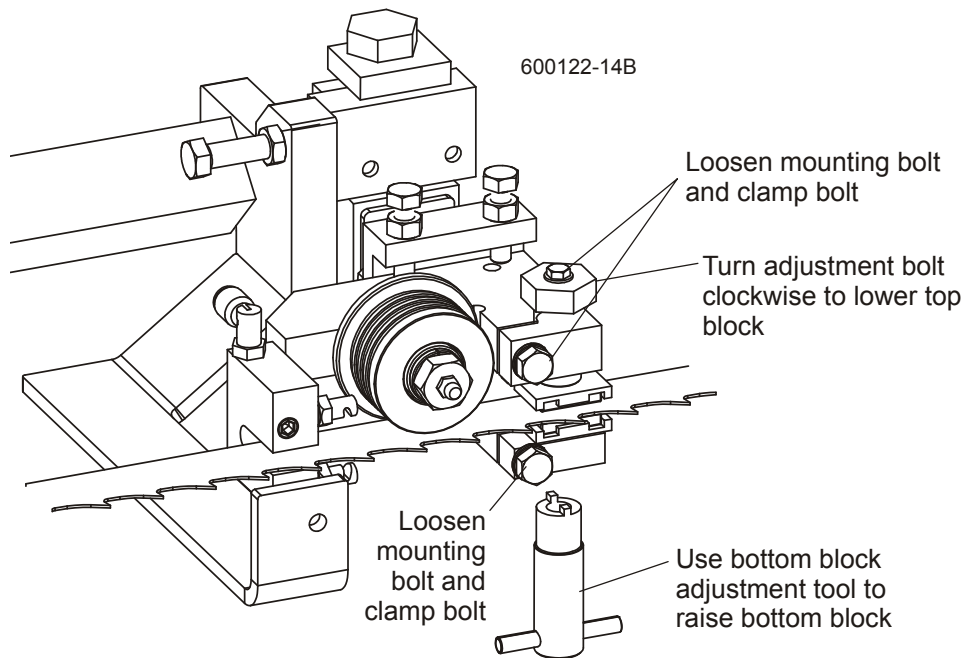


FIG. 5-1 REV. A1.00 - A9.03

# 5

## Maintenance

### Blade Guides (Standard Block/Roller Guides)

---

Preventing sap buildup on the blade is critical when using the high-performance blade guide system. If the wood you are sawing leaves sap buildup on the blade, increase the amount of oil mixed with the lube water.

4. **Rev. A9.03+:** Make sure the blade support channel in the center of the C-frame is 1/16" (1.5 mm) away from the blade. If not, loosen the mounting bolts and adjust the channel as necessary. Check the channel every blade change. Failing to maintain this adjustment will lead to early blade breakage.

See Figure 5-2.

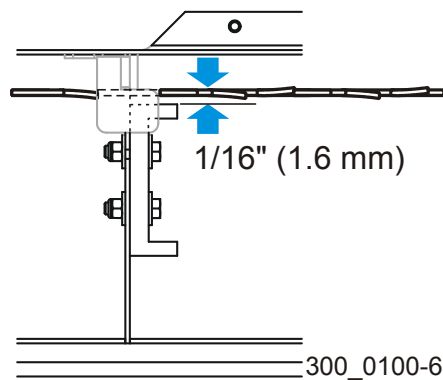


FIG. 5-2

## 5.2 Sawdust Removal



Remove the excess sawdust from the blade guide assemblies, blade wheel housings, throat and sawdust chute every blade change.



**WARNING!** Always keep clear of exiting sawdust. Keep hands, feet and any other objects away from the sawdust chute when operating sawmill. Failure to do so may result in serious injury.

**WARNING!** Always check to ensure the steel fingers inside the sawdust chute are in place before operating the sawmill. The steel fingers have been designed to help prevent a broken blade or some other object from becoming a projectile and exiting the sawdust chute. Failure to have these fingers in place may result in serious injury.



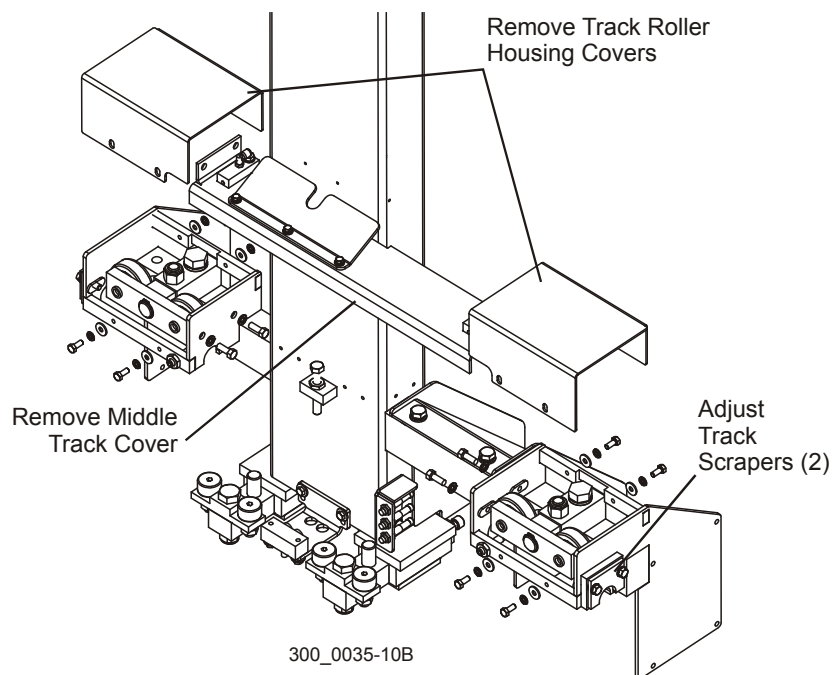
Remove all sawdust and debris from around the velocity fuse valves on the bottom of the log loader cylinders every 8 hours of operation.

Remove sawdust buildup from the area around the bottom up/down screw bellows. Also remove sawdust from the cable carrier tray.

### 5.3 Track Rails & Scrapers

Properly maintaining the sawmill carriage track is critical in preventing corrosion that can cause pitting and scaling on the rail surfaces. Pitted and scaled surfaces can, in turn, cause rough cuts or jerky power feed movement.

See Figure 5-1.



**FIG. 5-1**

1. Clean track rails to remove any sawdust and sap buildup every fifty hours of operation.

50

Use a light-grade sandpaper or emery cloth to sand off any rust or other adhering particles from the rails.



**CAUTION!** Keep track rails free of rust. Formation of rust on the track rail in the areas where the cam bearings roll can cause rapid deterioration of the track rail surface.

- 8 2. **Rev. A5.01 Only:** Lubricate the track rails with Dexron III ATF transmission fluid. Oil lubrication will help protect the rails from corrosive elements such as acid rain and/or moisture from nearby bodies of saltwater (if applicable). This lubrication is essential to maintain the integrity of the track rails and track rollers and to achieve long service life.

Locate the three oil fittings and open the covers. Use an oil can to apply Dexron III until the oiler pads are soaked. Repeat this procedure every eight hours of operation.

See Figure 5-3.

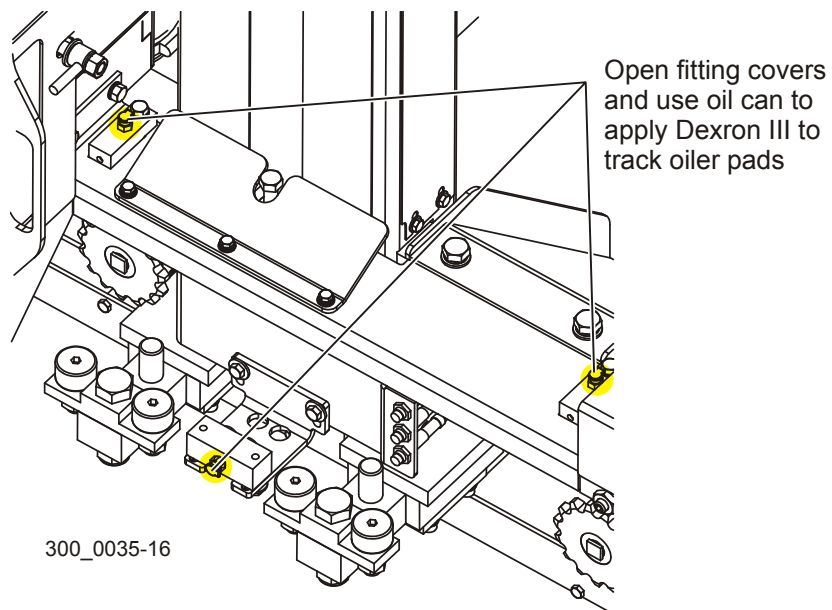


FIG. 5-3

- 50 **3. Rev. A1.00 - A5.00 Only:** The LT300 features an automatic track lubrication system that constantly keeps the top rail lubricated. Check the oil level in the reservoir at the top of the saw head mast every 50 hours of operation. Add Dexron III ATF transmission fluid, 10W30 motor oil, or 3-in-1 turbine oil as necessary. Oil lubrication will help protect the rails from corrosive elements such as acid rain and/or moisture from nearby bodies of saltwater (if applicable). This lubrication is essential to maintain the integrity of the track rails and track rollers and to achieve long service life.

See Figure 5-4.

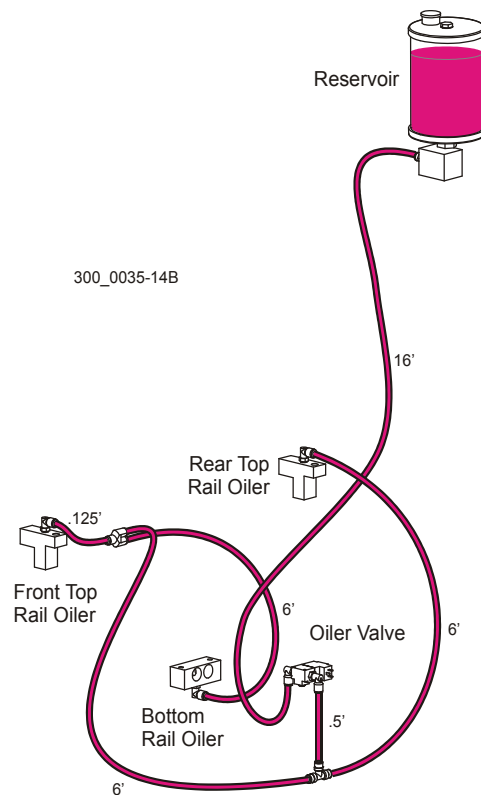


FIG. 5-4

- AR **4.** Check the track scrapers as needed. Make sure the scrapers fit firmly against the rail. To adjust each scraper, loosen the two mounting bolts and push the scraper downward until it fits firmly against the rail. Retighten the mounting bolts.



## 5.4 Miscellaneous

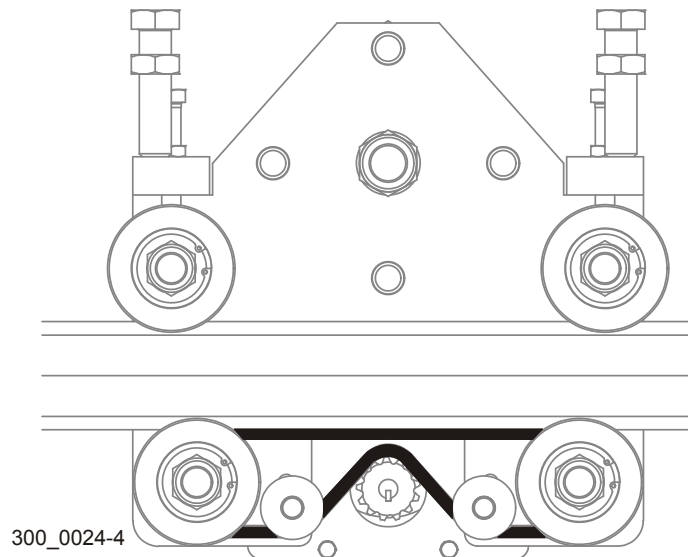
1. Oil all chains with Dexron III ATF every fifty hours of operation.



**CAUTION!** Do not use chain lube. It causes sawdust buildup in chain links.

2. Apply a thin film of a Dexron III ATF to the blade guide arm every fifty hours of operation to help prevent it from rusting.
3. Adjust the blade guide arm drive chain as necessary to prevent the arm from slipping. To adjust the chain, loosen the blade guide arm motor mounting plate bolts and slide the motor to take slack out of the chain. To adjust the chain, loosen the blade guide arm motor mounting plate bolts and slide the motor to take slack out of the chain.

See **Figure 5-5**. The routing of the blade guide arm chain is provided for your reference.



**FIG. 5-5**

4. Grease the pivot points of the operator seat (2), log clamp (1), log loader (6), log turner (1), rear toe board (1), board return arm pivots (5) and side supports (6) with a NLGI No. 2 grade lithium grease every fifty hours of operation.
5. Make sure all safety warning decals are readable. Remove sawdust and dirt. Replace any damaged or unreadable decals immediately. Order decals from your Customer Service Representative.

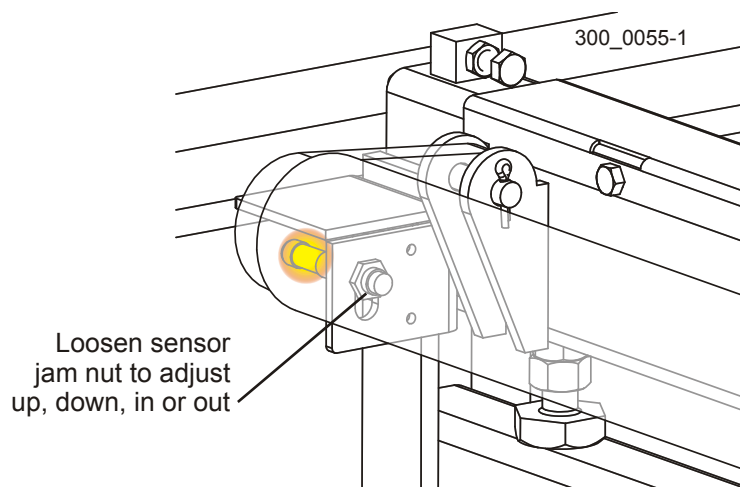
## 5.5 Proximity Sensors

Proximity sensors are used in various locations to ensure proper operation of the sawmill. Check the sensors periodically or when errors in operation occur with the following systems.

### 5.5.2 Toe Board Sensors (Rev. A1.00 - A5.01 Only)

See **Figure 5-6**. Three sensors are used to detect if the toe board rollers are up. The Toe/Rollers light on the control box indicates that the toe boards are up. If the toe boards are up while using the automatic board or pattern sawing programs and the saw carriage is moved forward, the Check Machine light will come on and the message “Toe/Roller Up” will appear on the display. Lower the toe boards before proceeding. The warning message will automatically clear after 3 seconds.

Check that the areas between the sensors and the toe boards are clear of sawdust buildup or obstructions that could result in false sensor readings. Be sure each sensor is lit when the corresponding toe board is down. Loosen the jam nut and adjust the sensor up or down so it is positioned over the toe board. Adjust the sensor away from the toe board until the sensor light goes out. Then adjust back in until the sensor light comes on plus one full turn. Tighten the jam nut.

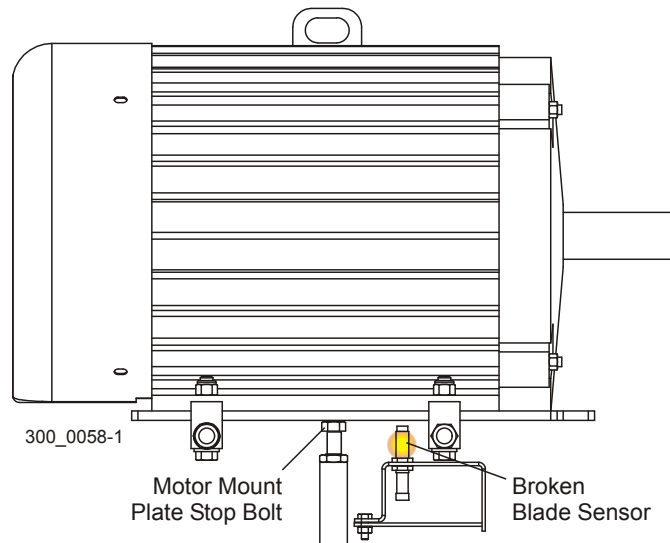


**FIG. 5-6**

### 5.5.3 Broken Blade Sensor

**See Figure 5-7.** A sensor located under the blade motor mounting plate detects when a blade breaks and stops the saw. When a blade breaks, the saw motor drops to its idle position, activating the sensor and alerting the operator with the Check Machine light and the message “Broken Blade Shutdwn” on the control display.

Check that the area between the sensor and the motor mount plate are clear of sawdust buildup and/or obstructions that could result in false sensor readings. Remove the blade tension and check that the sensor is lit when the motor is resting on the stop bolt. Loosen the jam nut and adjust the sensor away from the motor mount plate until the sensor light goes out. Then adjust back in until the sensor light comes on plus one 1/4 turn. Tighten the jam nut.



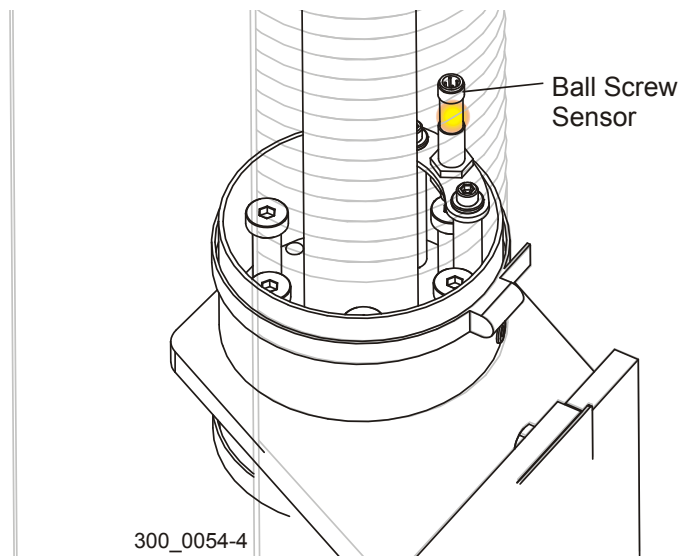
**FIG. 5-7**

**5.5.4 Up/Down Ball Screw Sensor (Rev. A3.00+)**


**See Figure 5-8.** A sensor located at the middle up/down ball screw mount is activated if the saw head hits an obstruction or lower travel limit as the head is being lowered. A break-away nut separates from the mount and the sensor alerts the operator with the Check Machine light and the message “Head Down Obstructed” on the control display.

Remove the obstruction and move the saw head up to re-engage the ball screw nut. If the error occurs at the bottom of the saw head travel limit, clear sawdust or obstructions from the area around the bottom of the ball screw bellows that might cause the nut to break-away before reaching the actual lower travel limit.




Check that the areas between the sensor and the ball screw nut are clear of sawdust buildup or obstructions that could result in false sensor readings. Be sure the sensor is lit when positioned over the ball screw nut. Loosen the jam nut and adjust the sensor away from the nut until the sensor light goes out. Then adjust back in until the sensor light comes on plus one full turn. Tighten the jam nut.

**FIG. 5-8**

## 5.6 Hydraulic System Maintenance

1.  Check the hydraulic tank fluid every fifty hours of operation. The sight gauge on the tank should indicate a fluid level between LOW and HIGH. Add an all-season hydraulic fluid such as Conoco HVI32 (previously Exxon Unavis HVI 26 formerly named J26) as needed to maintain proper fluid level.

If the fluid appears brown or cloudy, has an unusual 'burnt' odor, or if there is a sudden rise in oil temperature above 160°, completely drain the hydraulic tank and refill with new fluid. Also, remove and clean the suction strainer from the end of the hydraulic tank. Blow out any debris from the strainer and clean with a non-petroleum solvent before reinstalling to the tank.

2.  Inspect the hydraulic lines and fittings for leaks every fifty hours of operation or as fluid appears around the machine.
3.  Replace the S28 cartridge filter on the back of the hydraulic fluid tank every 500 hours of operation.
4.  Completely drain the reservoir and refill with new fluid every 2000 hours of operation. Also, remove and clean the suction strainer from the end of the hydraulic tank. Blow out any debris from the strainer and clean with a non-petroleum solvent before reinstalling to the tank.

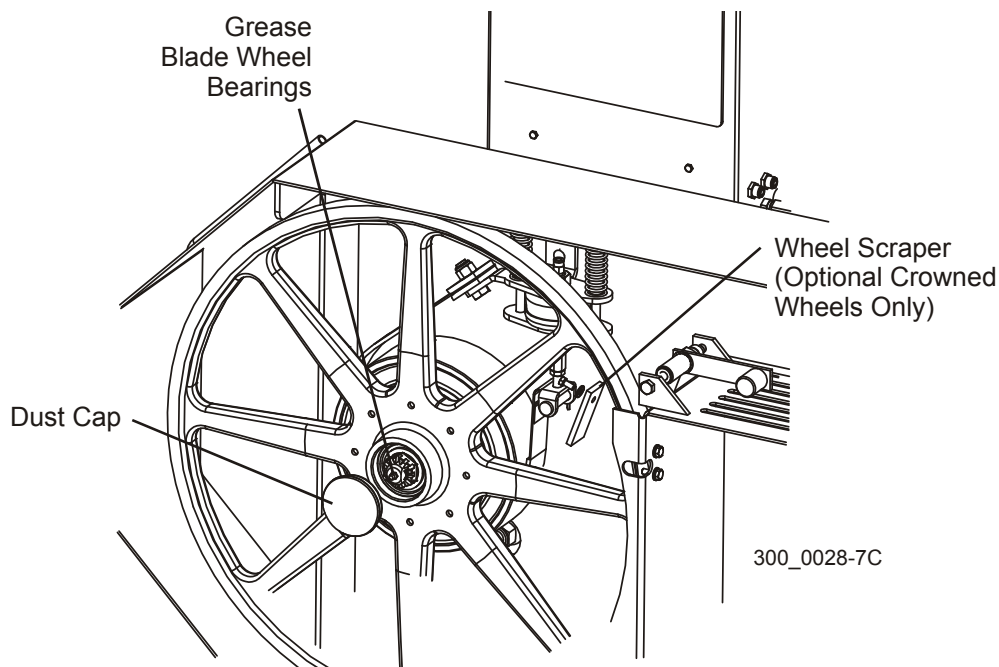
## 5.7 Blade Wheel Bearings & Scrapers

**50** **Standard Belted Blade Wheels Only:** Rotate the blade wheel belts and check them for wear. Rotating the belts every 50 hours will provide longer belt life. Replace belts as necessary. Use only B76 belts manufactured by Goodyear or Browning.

**A/R** **Optional Crowned Blade Wheels Only:** Inspect the blade wheel scrapers at every blade change. The scrapers are self-adjusting and only need replaced when they no longer contact the blade wheel. When one side of the scraper is worn, remove it and flip it over to use the other side.

**750** **See Figure 5-5.** Lubricate the blade wheel hub bearings every 750 hours of operation with a high-quality synthetic grease such as Amoco Rycon #2 or Chevron SRI #2.

1. Remove the dust cap from the hub.
2. Pump grease from a grease gun into the grease fitting until the new grease is seen exiting the hub bearings.
3. Replace the dust cap.

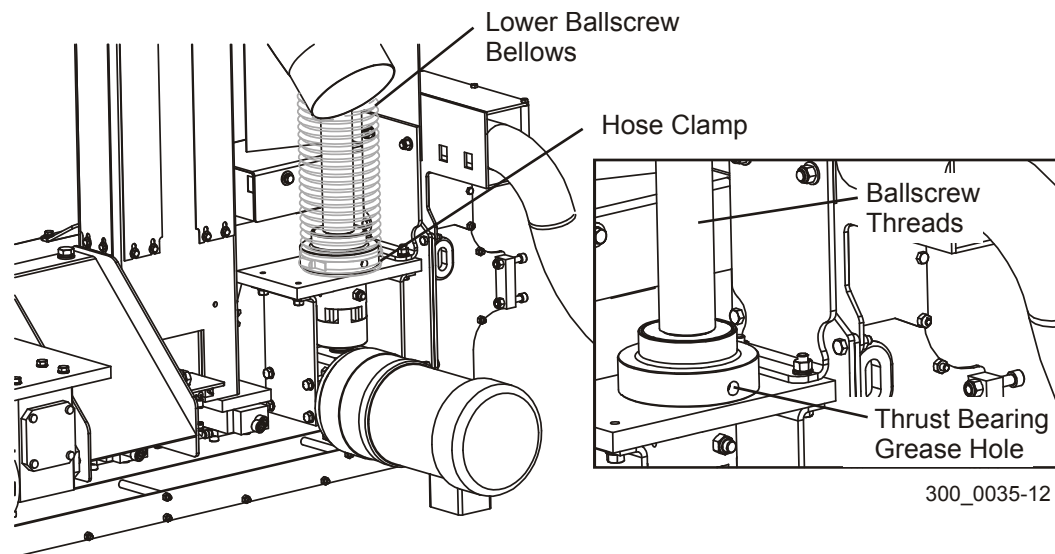


**FIG. 5-5**

## 5.8 Up/Down System

**NOTE:** The up/down ballscrew was replaced with a 2" ballscrew system with LT300 Rev. A3.00. All previous revision machines should be retrofitted with this system. Follow the maintenance routine described below.

**500** See **Figure 5-6.** Lubricate the up/down ballscrew with TriGEL-450R grease every 500 hours of operation. Wood-Mizer provides ballscrew grease in 10cc syringes for convenient application. Lubrication may be required sooner if environmental conditions require it. If the lubricant appears to have dispersed or is dry or crusted, reduce the maintenance interval.



**FIG. 5-6**

1. Lower the saw head all the way down and blow off sawdust from around the upper ballscrew bellows.
2. Raise the saw head all the way up and blow off sawdust from around the lower ballscrew bellows. Remove the top hose clamp from the lower bellows to access the ballscrew.
3. Inspect the condition of the ballscrew lubricant. If the lubricant appears to have dispersed or is dry or crusted, reduce the maintenance interval. Remove any old grease and/or particle buildup from the screw.
4. Apply 10cc of lubricant directly to the ballscrew threads. Start just below the ballscrew nut and lubricate the threads down as far as the lower bellows will allow.

5. Remove the bottom hose clamp from the lower bellows. Lift the bellows up and continue applying lubricant to the ballscrew threads down to the thrust bearing housing.
6. Remove the screw plugging the hole in the thrust bearing mount. Apply 5cc of lubricant through the hole to lubricate the thrust bearing. Replace the plug screw.
7. Reattach the lower ballscrew bellows and secure with the hose clamps. Raise and lower the saw head to work the grease along the entire length of the ballscrew.



Check the up/down gearbox oil level. Add a synthetic gear oil such as Mobil SHC 634 as needed.



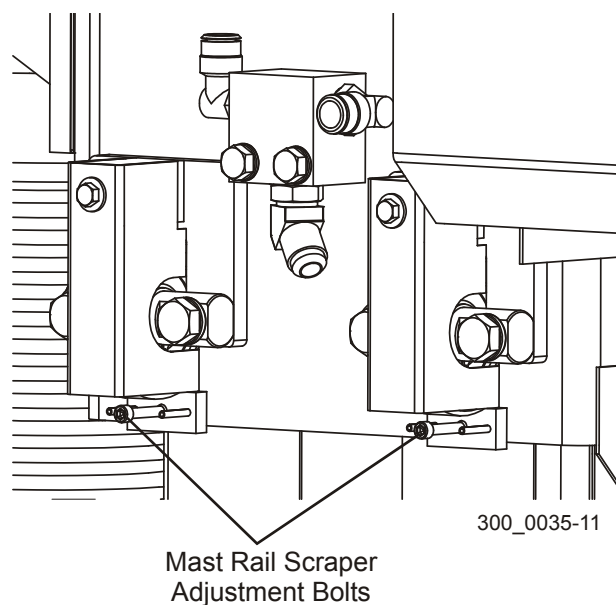
Drain and refill the gearbox with 8 - 11 ounces (Rev. A1.00 - A2.01) or 12 - 15 ounces (Rev. A3.00+) of oil after the first 100 hours of sawmill operation. Repeat every 5000 hours or once a year, whichever comes first.

Wood-Mizer offers replacement gear oil in 8 ounce bottles.



Check the up/down mast rails for excessive sawdust buildup every 50 hours of operation. Adjust the mast rail scrapers if necessary. Turn the adjustment bolts clockwise to tighten the scrapers. The scrapers should just be snug against the mast rails; do not overtighten.

**See Figure 5-9.**



**FIG. 5-6**



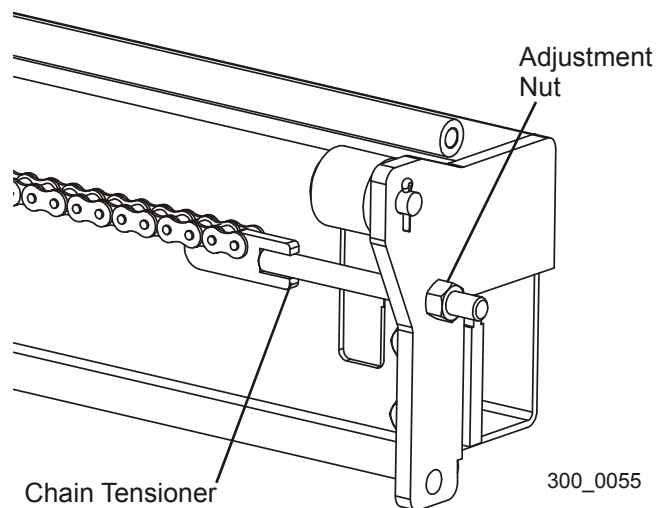
## 5.9 Power Feed

- 50 1. Check the feed chain tension every 50 hours of operation and adjust as needed. Measure the power feed chain tension with the saw head all the way toward the front of the mill (furthest from control station). Use the adjustment nut on the feed tensioner at the rear of the mill to tighten or loosen the power feed chain. Adjust the chain until it measures 13 inches ( $\pm 1/2$ " ) from the top of the top rail at its lowest point.



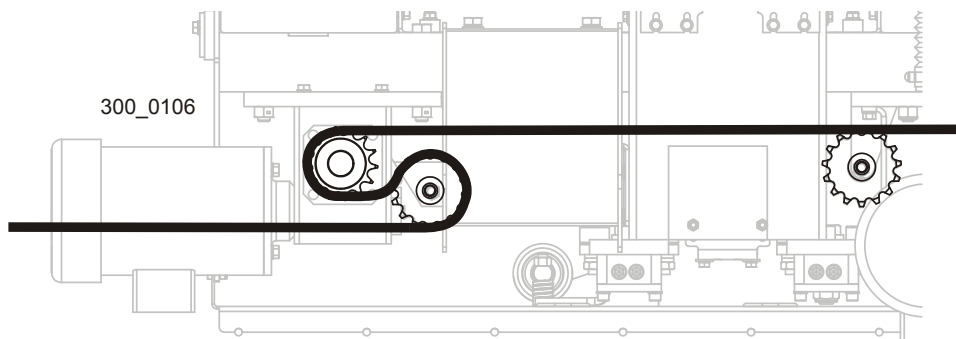
**CAUTION!** Do not overtighten the feed chain. Damage to the power feed motor may result.

See Figure 5-7.



**FIG. 5-9**

See Figure 5-8. Refer to this figure for feed chain routing instructions.



**FIG. 5-9**

2. Lubricate the feed chain with Dexron III ATF every fifty hours of operation.

50



**CAUTION!** Do not use chain lube. It causes sawdust buildup in chain links.

A/R

Check the power feed gearbox oil level. Add a synthetic gear oil such as Mobil SHC 634 as needed.

5000

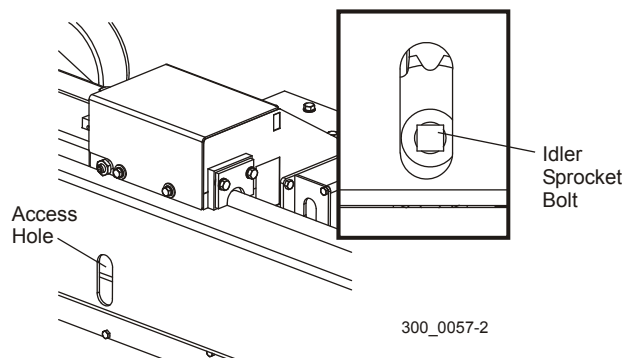
Drain and refill the gearbox with 19 - 22 ounces of oil after the first 100 hours of sawmill operation. Repeat every 5000 hours or once a year, whichever comes first.

Wood-Mizer offers replacement gear oil in 8 ounce bottles.

3. Inspect the power feed drive system for worn sprockets, chain links, etc... every 500 hours of operation. Replace or repair components as necessary.

500

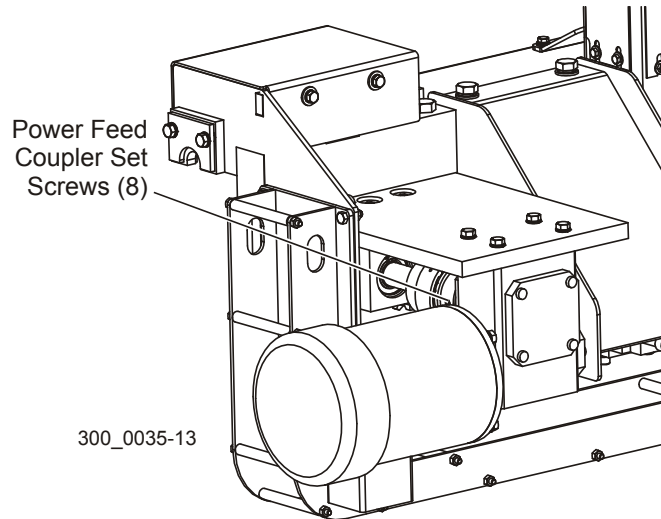
**See Figure 5-10.** An access hole is provided in the bed frame tube to allow removal of the feed chain idler sprocket without disassembling the entire power feed unit. Move the saw carriage forward or backward until the sprocket bolt can be seen through the access hole.



**FIG. 5-8**

**See Figure 5-11.** Check that the feed drive shaft coupler set screws are tight.

**Note:** Earlier models may not have 8 set screws securing the coupler to the shaft. A second set screw should be added at each of the 4 locations to hold the first set screw in position.



**FIG. 5-8**

## 5.10 Drive Belt Tension & Alignment



Check the drive belt tension and alignment after the first 5 hours of operation, then every 50 hours thereafter.



**WARNING!** Do not for any reason adjust the drive belt with the motor running. Doing so may result in serious injury.

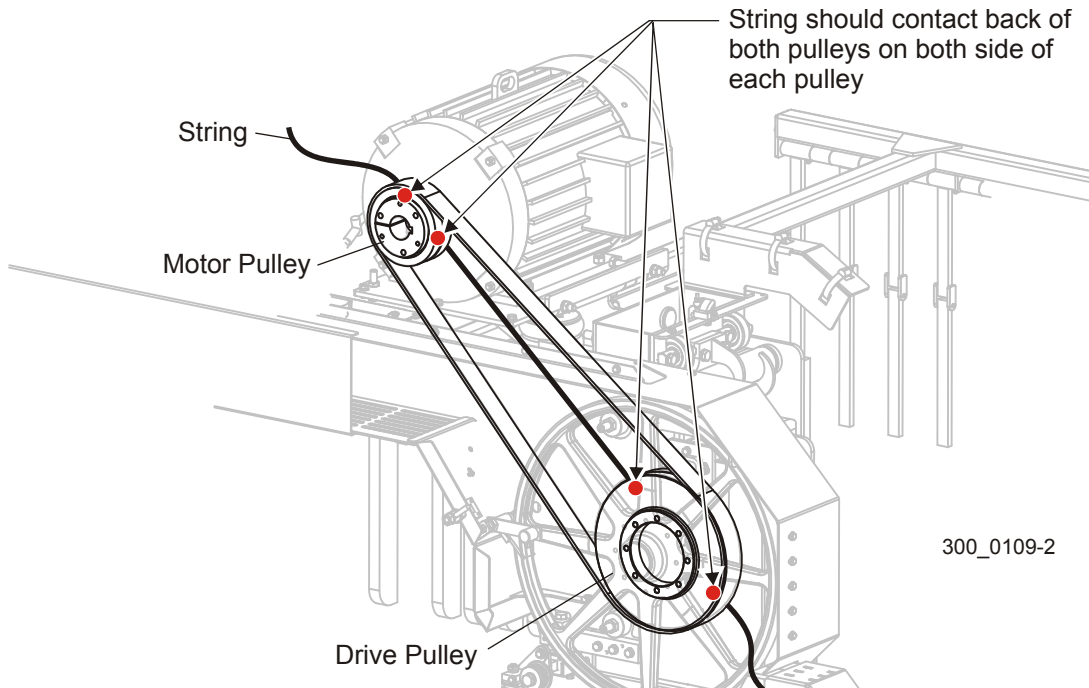


**CAUTION!** Always keep proper tension on the drive belt. Improper tension can ruin the belt. A loose drive belt can also cause wavy cuts, the blade to slow or stop in the cut or the cruise control to not operate properly.

Before tensioning the belt, check the alignment of the motor and drive pulleys. Misaligned pulleys will result in reduced belt life.

1. Install, tension and track a blade. Turn the machine off, disconnect and lock out the power supply.
2. Remove belt covers as necessary and place a string across the back of the drive pulley. Pull the string tight and position it contacts the pulley on each side of the pulley.
3. Check the position of the motor pulley against the sting. When the pulleys are properly aligned the string will contact both sides of each pulley.
4. If necessary, adjust the motor pulley so it is aligned with the drive pulley. To move the motor pulley straight in or out, loosen the pulley bushing and move the pulley in or out on the motor shaft. To adjust the angle of the motor pulley, loosen the motor mount bolts and tilt the motor as necessary. Retighten the motor pulley bushing and/or mounting bolts and recheck the alignment with the string.

See Figure 5-12.



**FIG. 5-12**

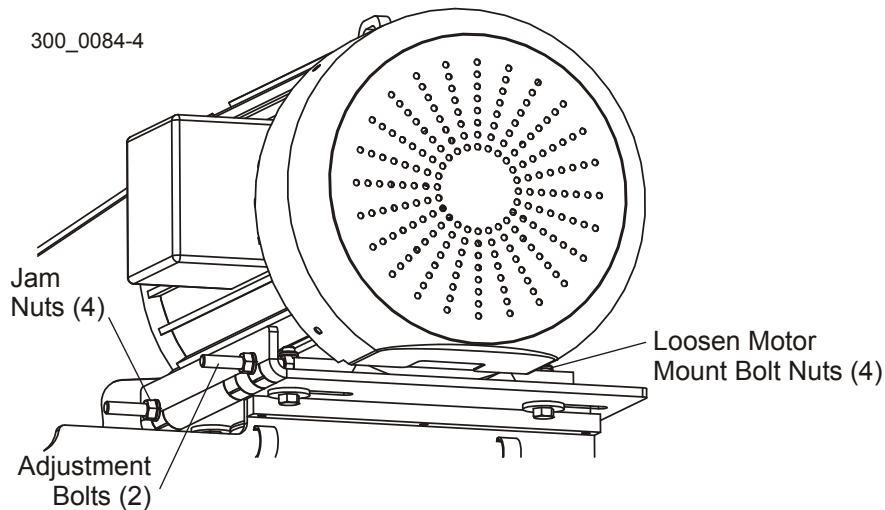
5. Check that the belt is properly tensioned.

See the table below for drive belt tension specifications.

Belt Type	After First	Then Every	Belt Tension
PD (after Rev. A8.00)	5 hrs	50 hrs	1/2" (12.5mm) deflection with 34 lbs. (15.4kg) of deflection force
V (before Rev. A8.00)	5 hrs	50 hrs	1/2" (12.5mm) deflection with 24 lbs. (10.9kg) of deflection force

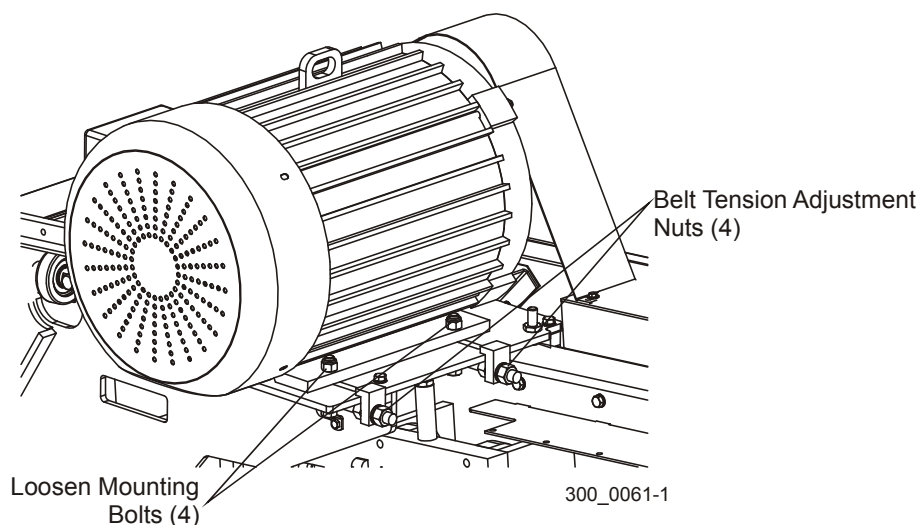
See Figure 5-13.

**Rev. A7.00+:** To adjust the belt, loosen the four motor mount bolt nuts. Loosen the adjustment bolt jam nuts and turn both adjustment bolts to move the motor and tension the belt. Recheck belt tension, adjust as necessary and retighten the adjustment bolt jam nuts and motor mount bolt nuts.



**FIG. 5-13 REV. A7.00+**

**See Figure 5-14. Rev. A1.00 - A6.01:** To adjust the belt, loosen the nuts on the four motor mount bolts. Locate the adjusting nuts underneath the motor. Turn the inside nuts clockwise down the threaded rod about 1/2" (13 mm). Turn the outside nuts until they are tight. Recheck belt tension and adjust as necessary.



**FIG. 5-14 REV. A1.00 - A6.01**

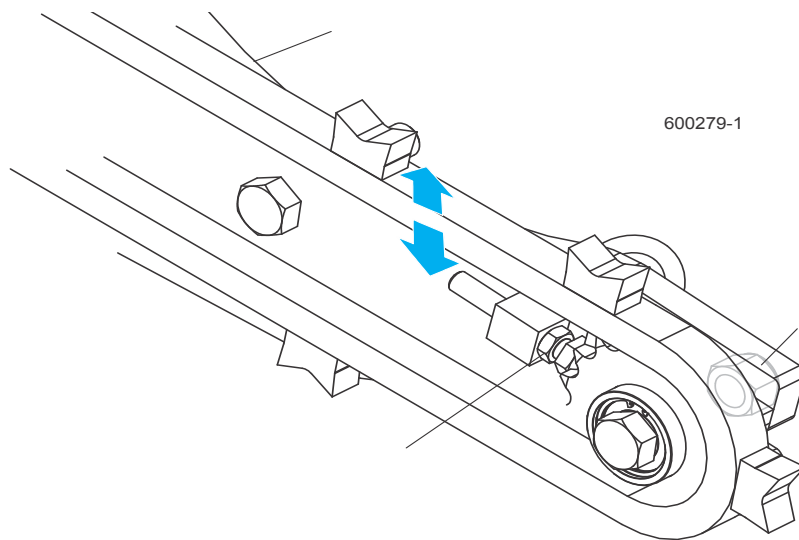


## 5.11 Turner Chain Tension

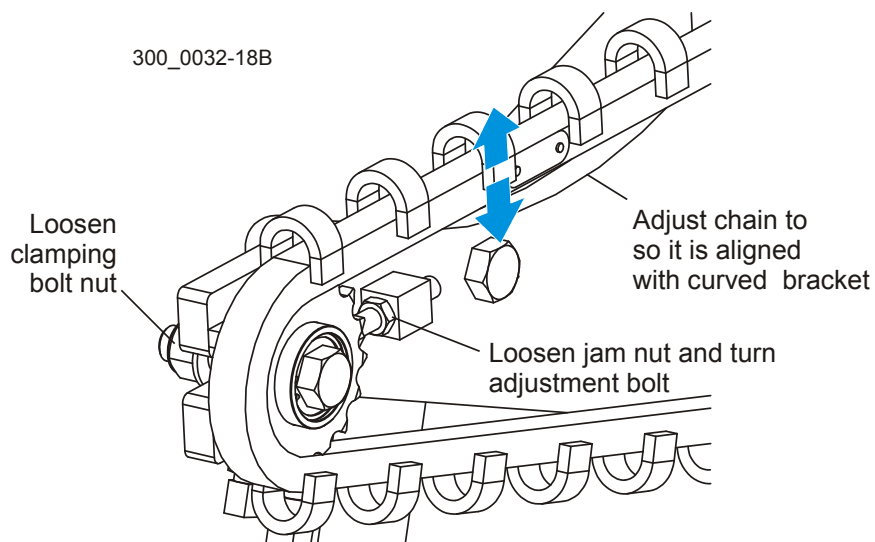


Adjust the turner chain tension the log turner(s) as necessary to keep the turner(s) operating properly. If the chain(s) become too loose, the log will catch on the support bracket and not turn.

See **Figure 5-15**. To adjust the chain tension, loosen the clamping bolt nut and the jam nut on the adjustment bolt. Turn the adjustment bolt counterclockwise to tighten the chain until it is aligned with the curved portion of the support bracket. Retighten the jam nut and the clamping bolt nut.



**FIG. 5-15 REV. B4.00+**



**FIG. 5-15 REV. A1.00 - B3.02**





# MAINTENANCE LOG

PROCEDURE	REFERENCE	TOTAL HOURS OF OPERATION																		
		550 HRS	600 HRS	650 HRS	700 HRS	750 HRS	800 HRS	850 HRS	900 HRS	950 HRS	1000 HRS									
Clean and lubricate track, check track scrapers	<a href="#">See Section 5.3</a>																			
Check mast rails and adjust scrapers	<a href="#">See Section 5.8</a>																			
Grease pivot points and bearings/Oil chains	<a href="#">See Section 5.4</a>																			
Check drive belt tension	<a href="#">See Section 5.10</a>																			
Rotate drive/idle blade wheel belts/Check for wear (Standard Belted Blade Wheels Only)	<a href="#">See Section 5.7</a>																			
Lubricate blade wheel bearings	<a href="#">See Section 5.7</a>																			
Lubricate feed chain and check chain tension	<a href="#">See Section 5.9</a>																			
Lubricate up/down ballscrew & thrust bearing	<a href="#">See Section 5.8</a>																			
Replace up/down and power feed gearbox oil	<a href="#">See Section 5.8</a> <a href="#">See Section 5.9</a>																			
Inspect feed chain, sprockets and coupler	<a href="#">See Section 5.9</a>																			
Inspect hydraulic lines & fittings	<a href="#">See Section 5.6</a>																			
Check hydraulic fluid level	<a href="#">See Section 5.6</a>																			
Replace hydraulic system filter	<a href="#">See Section 5.6</a>																			
Inspect hydraulic pump motor brushes	<a href="#">See Section 5.6</a>																			

FILL IN THE DATE AND THE MACHINE HOURS AS YOU PERFORM EACH PROCEDURE.  
A SHADED BOX INDICATES MAINTENANCE IS NOT NEEDED AT THIS TIME.

# MAINTENANCE LOG

TOTAL HOURS OF OPERATION  
 FILL IN THE DATE AND THE MACHINE HOURS AS YOU PERFORM EACH PROCEDURE.  
 A SHADED BOX INDICATES MAINTENANCE IS NOT NEEDED AT THIS TIME.

PROCEDURE	REFERENCE	TOTAL HOURS OF OPERATION																	
		1050 HRS	1100 HRS	1150 HRS	1200 HRS	1250 HRS	1300 HRS	1350 HRS	1400 HRS	1450 HRS	1500 HRS								
Clean and lubricate track, check track scrapers	<a href="#">See Section 5.3</a>																		
Check mast rails and adjust scrapers	<a href="#">See Section 5.8</a>																		
Grease pivot points and bearings/Oil chains	<a href="#">See Section 5.4</a>																		
Check drive belt tension	<a href="#">See Section 5.10</a>																		
Rotate drive/idle blade wheel belts/Check for wear (Standard Belted Blade Wheels Only)	<a href="#">See Section 5.7</a>																		
Lubricate blade wheel bearings	<a href="#">See Section 5.7</a>																		
Lubricate feed chain and check chain tension	<a href="#">See Section 5.9</a>																		
Lubricate up/down ballscrew & thrust bearing	<a href="#">See Section 5.8</a>																		
Replace up/down and power feed gearbox oil	<a href="#">See Section 5.8</a> <a href="#">See Section 5.9</a>																		
Inspect feed chain, sprockets and coupler	<a href="#">See Section 5.9</a>																		
Inspect hydraulic lines & fittings	<a href="#">See Section 5.6</a>																		
Check hydraulic fluid level	<a href="#">See Section 5.6</a>																		
Replace hydraulic system filter	<a href="#">See Section 5.6</a>																		
Inspect hydraulic pump motor brushes	<a href="#">See Section 5.6</a>																		

# MAINTENANCE LOG

**TOTAL HOURS OF OPERATION**

FILL IN THE DATE AND THE MACHINE HOURS AS YOU PERFORM EACH PROCEDURE.  
A SHADED BOX INDICATES MAINTENANCE IS NOT NEEDED AT THIS TIME.

PROCEDURE	REFERENCE	TOTAL HOURS OF OPERATION																		
		1550 HRS	1600 HRS	1650 HRS	1700 HRS	1750 HRS	1800 HRS	1850 HRS	1900 HRS	1950 HRS	2000 HRS									
Clean and lubricate track, check track scrapers	<a href="#">See Section 5.3</a>																			
Check mast rails and adjust scrapers	<a href="#">See Section 5.8</a>																			
Grease pivot points and bearings/Oil chains	<a href="#">See Section 5.4</a>																			
Check drive belt tension	<a href="#">See Section 5.10</a>																			
Rotate drive/idle blade wheel belts/Check for wear (Standard Belted Blade Wheels Only)	<a href="#">See Section 5.7</a>																			
Lubricate blade wheel bearings	<a href="#">See Section 5.7</a>																			
Lubricate feed chain and check chain tension	<a href="#">See Section 5.9</a>																			
Lubricate up/down ballscrew & thrust bearing	<a href="#">See Section 5.8</a>																			
Replace up/down and power feed gearbox oil	<a href="#">See Section 5.8</a> <a href="#">See Section 5.9</a>																			
Inspect feed chain, sprockets and coupler	<a href="#">See Section 5.9</a>																			
Inspect hydraulic lines & fittings	<a href="#">See Section 5.6</a>																			
Check hydraulic fluid level	<a href="#">See Section 5.6</a>																			
Replace hydraulic system filter	<a href="#">See Section 5.6</a>																			
Inspect hydraulic pump motor brushes	<a href="#">See Section 5.6</a>																			

# MAINTENANCE LOG

## TOTAL HOURS OF OPERATION

FILL IN THE DATE AND THE MACHINE HOURS AS YOU PERFORM EACH PROCEDURE.  
A SHADED BOX INDICATES MAINTENANCE IS NOT NEEDED AT THIS TIME.

PROCEDURE	REFERENCE	2050 HRS	2100 HRS	2150 HRS	2200 HRS	2250 HRS	2300 HRS	2350 HRS	2400 HRS	2450 HRS	2500 HRS
Clean and lubricate track, check track scrapers	<a href="#">See Section 5.3</a>										
Check mast rails and adjust scrapers	<a href="#">See Section 5.8</a>										
Grease pivot points and bearings/Oil chains	<a href="#">See Section 5.4</a>										
Check drive belt tension	<a href="#">See Section 5.10</a>										
Rotate drive/idle blade wheel belts/Check for wear (Standard Belted Blade Wheels Only)	<a href="#">See Section 5.7</a>										
Lubricate blade wheel bearings	<a href="#">See Section 5.7</a>										
Lubricate feed chain and check chain tension	<a href="#">See Section 5.9</a>										
Lubricate up/down ballscrew & thrust bearing	<a href="#">See Section 5.8</a>										
Replace up/down and power feed gearbox oil	<a href="#">See Section 5.8</a> <a href="#">See Section 5.9</a>										
Inspect feed chain, sprockets and coupler	<a href="#">See Section 5.9</a>										
Inspect hydraulic lines & fittings	<a href="#">See Section 5.6</a>										
Check hydraulic fluid level	<a href="#">See Section 5.6</a>										
Replace hydraulic system filter	<a href="#">See Section 5.6</a>										
Inspect hydraulic pump motor brushes	<a href="#">See Section 5.6</a>										

# MAINTENANCE LOG

**TOTAL HOURS OF OPERATION**

FILL IN THE DATE AND THE MACHINE HOURS AS YOU PERFORM EACH PROCEDURE.  
A SHADED BOX INDICATES MAINTENANCE IS NOT NEEDED AT THIS TIME.

PROCEDURE	REFERENCE	2550 HRS	2600 HRS	2650 HRS	2700 HRS	2750 HRS	2800 HRS	2850 HRS	2900 HRS	2950 HRS	3000 HRS
		Clean and lubricate track, check track scrapers	<a href="#">See Section 5.3</a>								
Check mast rails and adjust scrapers	<a href="#">See Section 5.8</a>										
Grease pivot points and bearings/Oil chains	<a href="#">See Section 5.4</a>										
Check drive belt tension	<a href="#">See Section 5.10</a>										
Rotate drive/idle blade wheel belts/Check for wear (Standard Belted Blade Wheels Only)	<a href="#">See Section 5.7</a>										
Lubricate blade wheel bearings	<a href="#">See Section 5.7</a>										
Lubricate feed chain and check chain tension	<a href="#">See Section 5.9</a>										
Lubricate up/down ballscrew & thrust bearing	<a href="#">See Section 5.8</a>										
Replace up/down and power feed gearbox oil	<a href="#">See Section 5.8</a> <a href="#">See Section 5.9</a>										
Inspect feed chain, sprockets and coupler	<a href="#">See Section 5.9</a>										
Inspect hydraulic lines & fittings	<a href="#">See Section 5.6</a>										
Check hydraulic fluid level	<a href="#">See Section 5.6</a>										
Replace hydraulic system filter	<a href="#">See Section 5.6</a>										
Inspect hydraulic pump motor brushes	<a href="#">See Section 5.6</a>										

## SECTION 6 TROUBLESHOOTING

### 6.1 Error Codes

Err. #	Msg on Display	Err	Wrn	3 Sec	Cause	Cleared by	Msg #
1	Toe/Roller Up Rev. A1.00 - A5.01 Only		x	x	Toe or Roller up and - 1) Pattern mode, head fwd 2) Board mode, head fwd. This error will only occur once per head fwd for 3 seconds.	3 Sec Timer	101
2	Blade not tensioned	x			1) Mtr key to start and blade not tensioned 2) Loss of air pressure when mtr is running.	Key Swt to OFF, tension blade, air pressure restored	102
3	Broken Blade Shutdwn	x			1) Blade breaks 2) No blade on mill and Key Swt to Start	Key Swt to OFF	103
4	Hyd Pump Overload	x			Hyd. Motor bad, shorted etc. that trips overload and the hyd. Pump is requested	Reset overload, Hyd pump turns off	104
5	U/D Invertor Drive	x			Various errors, see invertor drive manual	Press E-Stop and wait for the display to no longer show the error message. Reset drive by pressing the rst button (not recommend for normal operation)	105

## 6

## Troubleshooting

## Error Codes

Err. #	Msg on Display	Err	Wrn	3 Sec	Cause	Cleared by	Msg #
6	PF Invertor Drive	x			Various errors, see invertor drive manual	Press E-Stop and wait for the display to no longer show the error message. Reset drive by pressing the rst button (not recommend for normal operation)	106
7	Blade Mtr Over-temp	x			Heavy use of motor	Let motor rest until internal thermostats close. Turning OFF the key switch will clear the error even if the thermostats are still open. Turning the key to ON will show the error is the themostats are open.	107
8	Target Not Reached		x	x	An automatic drop was initiated but the head failed to reach the target in 5 seconds	3 Sec Timer	108



Err. #	Msg on Display	Err	Wrn	3 Sec	Cause	Cleared by	Msg #
9	Blade Brake Engaged	x			Malfunction of brake air solenoid.	Key OFF, correct problem. This error will not occur until the motor contactors switch from start to run so the operator will see the motor run for 4 seconds then turn off.	109
10	Head at Lower Limit		x	x	Head within 1" of bed	3 Sec Timer	110
11	Head at Upper Limit		x	x	Head within 1" of top of mast	3 Sec Timer	111
12	Invalid PF Cal Value		x	x	Head PF not calibrated	3 Sec Timer	112
13	PF Range Error		x	x	Failed to move speed control when instructed during calibration or error in feed control	3 Sec Timer	113
14	!!! A/D Failure !!!	x			System failure	Correction of A/D	124
15	Head Down Obstructed (Added Rev. A3.00)	x			Obstruction with saw head during downward travel.	Remove obstruction and raise saw head to re-engage ballscrew nut.	119
16	Not Used						125
17	Head Travel Sensor Err	x		x	Stop prox was detected but not the slow down prox. (invalid condition).	3 sec timer. Readjust the head travel prox.'s, move the head off sensing strips	126

**6****Troubleshooting***Error Codes*

---

<b>Err. #</b>	<b>Msg on Display</b>	<b>Err</b>	<b>Wrn</b>	<b>3 Sec</b>	<b>Cause</b>	<b>Cleared by</b>	<b>Msg #</b>
<b>18</b>	Exceeded HP limit	x		x	HP exceeded 75HP for 150ms	3 sec timer. Note: the PF will stop and will not work until the operator releases the right joystick.	150

## 6.2 Blade Guides

PROBLEM	CAUSE	SOLUTION
<b>Heat In Blade</b>	Blade guide blocks not properly aligned.	Align blade guides ( <a href="#">See Section 7.2</a> ).
	Groove in blade guide roller not aligned with gap between blade guide blocks.	Adjust roller to start a new groove.
<b>Slow Or Wavy Sawing</b>	Blade guides not properly aligned.	Align blade guides ( <a href="#">See Section 7.2</a> ).
	Buildup on blade.	Use or increase blade lube.
<b>Sparks From Blade Guide Inserts</b>	Weld in a new blade contacting guide blocks.	Continue using blade until weld eventually wears.
	Chipped blade guide block.	Replace.
	Rough surface on blade guide block (Ceramic Only).	Send block for grinding/honing or replace.



## SECTION 7 ALIGNMENT

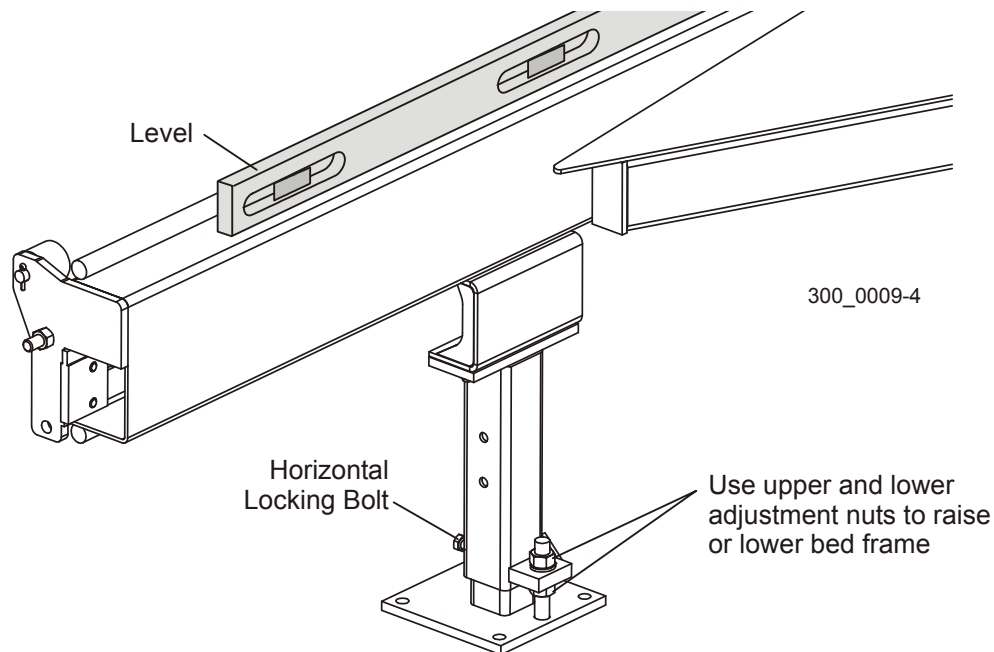
### 7.1 Bed Frame

#### 7.1.1 Level Bed Frame In Length Direction

**NOTE:** If the floor is extremely unlevel, the sawmill legs may not provide enough adjustment to level the bed frame in the length direction. This is not critical to maintain sawing accuracy. Level the sawmill in the length direction as closely as possible.

Move the saw head so it is positioned over the log clamp tube at the middle of the bed frame. Place a level on the main frame tube, near the front end of the sawmill. Adjust the front leg if necessary until the tube is level at that location.

**See Figure 7-1.** Loosen the horizontal locking bolt before adjusting the leg. Use the bottom and top adjusting nuts to raise or lower the frame tube until it is level. Tighten the adjustment nuts and the horizontal locking bolt to secure the leg in position.



**FIG. 7-1**

Move the level to the center of the tube and adjust the middle legs if necessary. Move the level to the rear of the tube and adjust the rear leg if necessary.

# 7 Alignment

## Level Bed Frame In Width Direction

### 7.1.2 Level Bed Frame In Width Direction

See Figure 7-2. To level the bed in the width direction, place two pieces of straight tubing between the front two bed rail supports. Place a level across both tubes, near the front bed rail ('A'). Adjust the outer front leg to level the bed. Move the level to the other end of the tubes ('B') and use the second outer leg to adjust level. Move the straight tubes to the rear two bed rail supports and adjust the two outer rear legs until the bed is level.

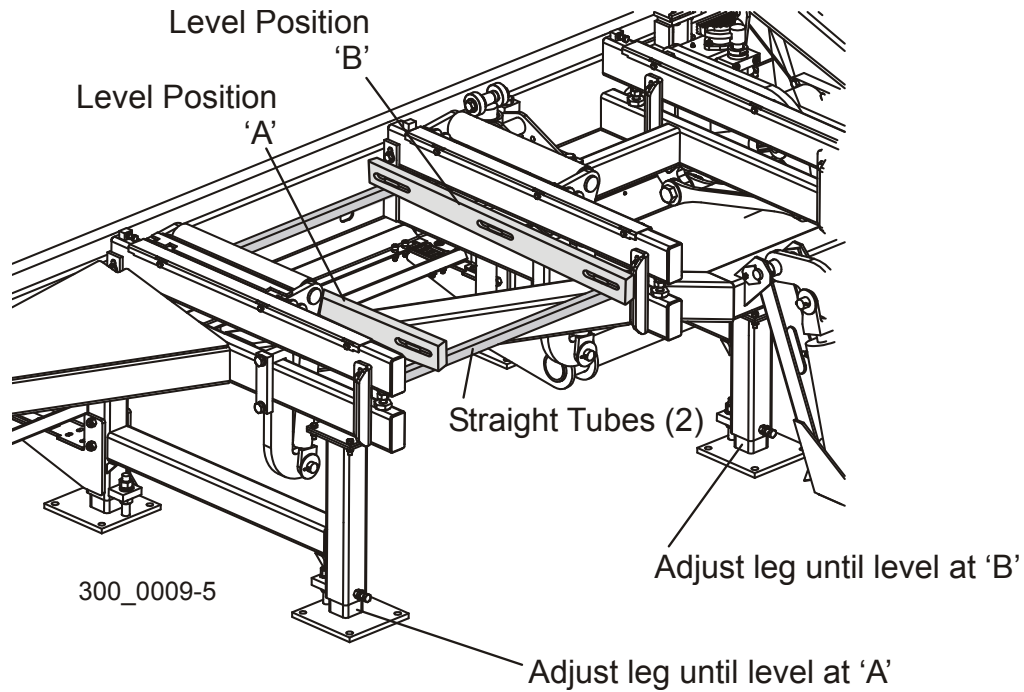
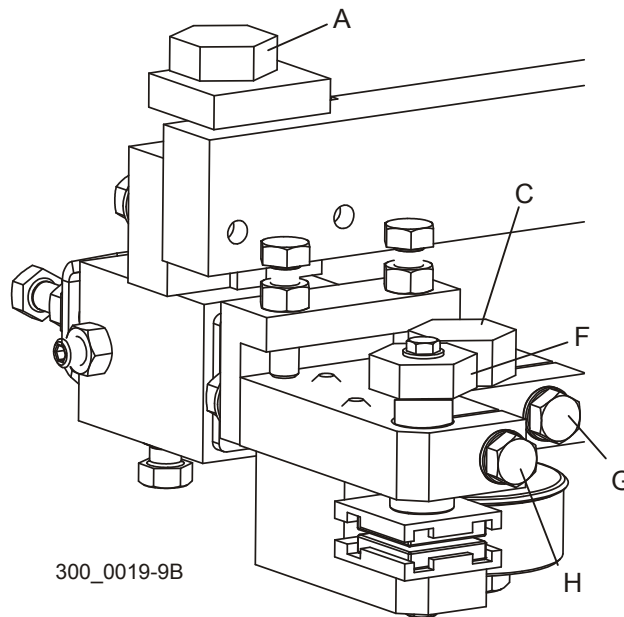


FIG. 7-2

**7.1.3**    *Level Saw Head*

Install a blade around the blade wheels. Tension and track the blade. Move the saw carriage so the blade is positioned over the log clamp tube. Adjust the blade guide arm all the way out.

**See Figure 7-3.** Adjust the blade guides so they do not touch the blade in any way. Loosen clamp bolt (H) and turn the top guide block bolt (F) counterclockwise to raise the top guide block off the blade. Turn blade guide assembly bolt (A) counterclockwise to move the bottom guide block down off the blade. Check that the blade guide roller does not touch the blade. Loosen clamp bolt (G) and turn roller bolt (C) if necessary to move roller away from blade.



**FIG. 7-3**

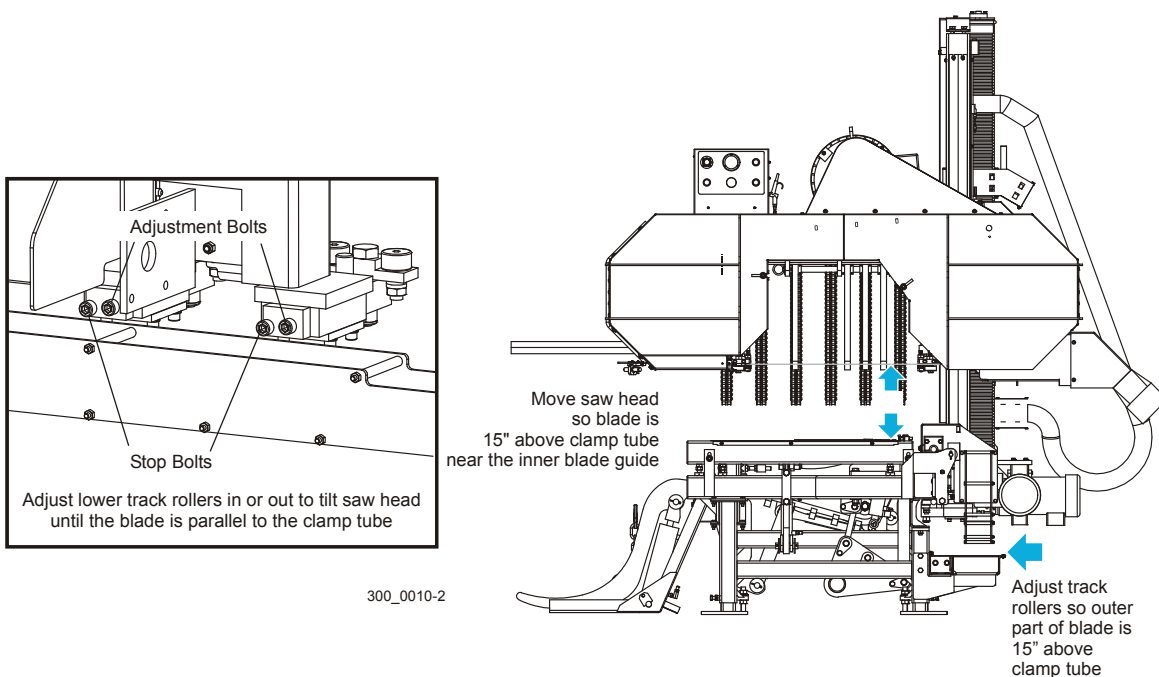
# 7 Alignment

## Level Saw Head

**See Figure 7-4.** Raise the saw head until the blade measures 15" above the clamp tube by actual measurement with a tape or rule from the bottom of the blade to the clamp tube near the inner blade guide. Measure the distance to the blade at the outer end of the clamp tube. The two measurements should be equal. If necessary, adjust the lower track rollers to tilt the saw head so the blade is parallel to the clamp tube.

To tilt the outer side of the saw head down toward the bed, loosen the adjustment bolts. Turn each adjustment bolt equally, one revolution at a time and remeasure the distance from the blade to the clamp tube. Once the blade is parallel to the clamp tube, tighten the stop bolts until they stop against the roller mount block.

To tilt the outer side of the saw head up, loosen the stop bolts and tighten the adjustment bolts. Turn each adjustment bolt equally, one revolution at a time and remeasure the distance from the blade to the clamp tube. Once the blade is parallel to the clamp tube, tighten the stop bolts until they stop against the roller mount block.

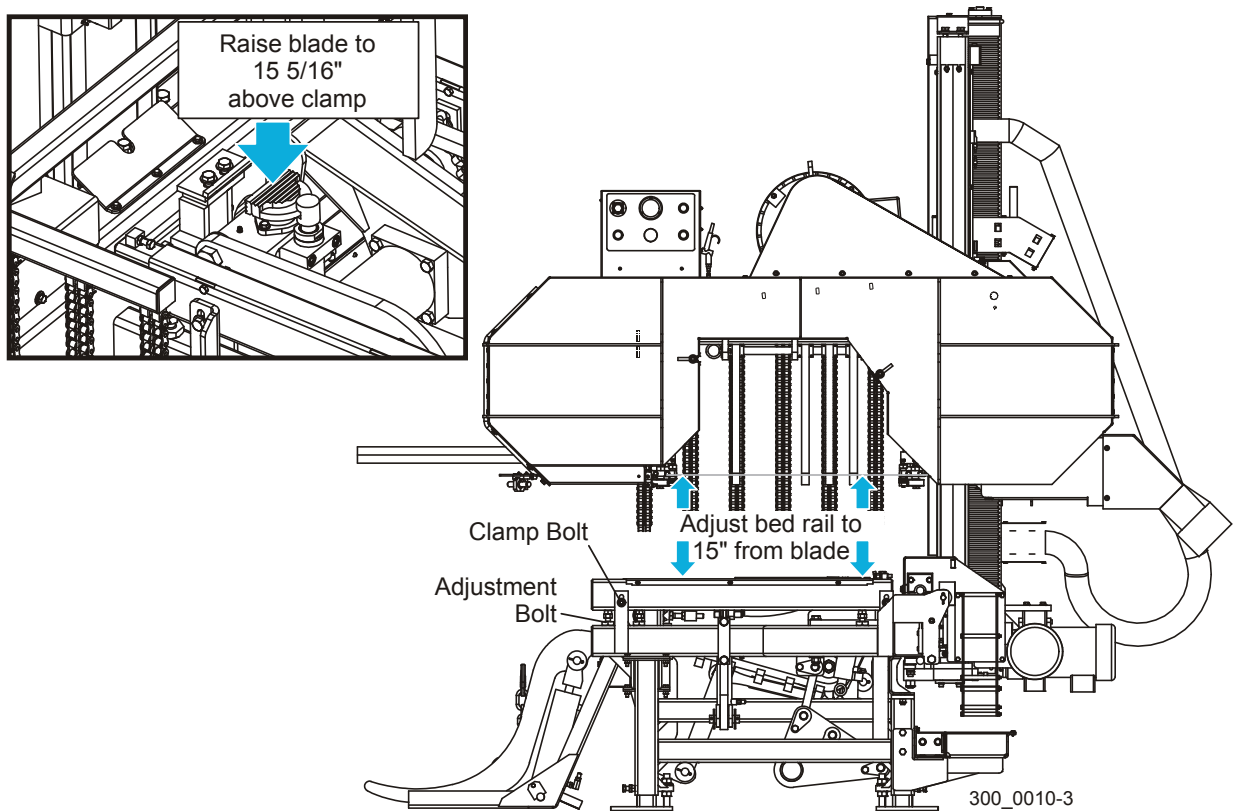


**FIG. 7-4**



**7.1.4 Level Bed Rails**

See Figure 7-5. Move the log clamp in until it is 10" from the clamp stop. Adjust the clamp down to its lowest position. Raise the saw head until the blade measures 15 5/16" above the top of the clamp. Move the saw carriage so the blade is positioned over the front bed rail. Measure the distance from the bottom of the blade to the bed rail cover at each end of the bed rail. Both measurements should be 15" (5/16" above the clamp [ $\pm 1/16"$ ]). Loosen the bed rail clamp bolts and turn the bed rail adjustment bolts to raise or lower the bed rail, if necessary. Retighten the clamp bolts and repeat for the remaining bed rails.



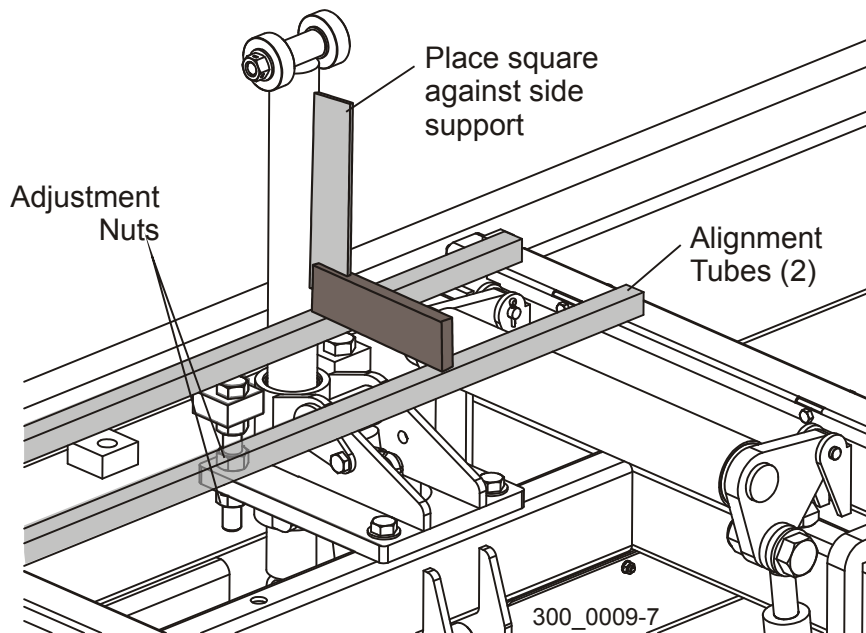
**FIG. 7-5**

# 7 Alignment

## Align Side Supports

### 7.1.5 Align Side Supports

**See Figure 7-6.** Place square alignment tubes (Part No. S12831 - 2 required) across the bed rails in front of one of the side supports. Use the controls to raise the side supports all the way up. Set a square on the tubes and place against the side support. The side support should be square to the bed or tilted slightly forward  $1/32''$  (0.8 mm). Adjust the tilt of the side support if necessary.



**FIG. 7-6**

To tilt the side support forward, loosen the top adjustment nuts and tighten the lower adjustment nuts. Adjust both sets of adjustment nuts on each side of the side support evenly. To tilt the side support back, loosen the bottom adjustment nuts and tighten the top adjustment nuts.

## 7.2 Blade Guides (Standard Block/Roller Guides)

**NOTE:** Block/Roller Guides are standard on the LT300 (Rev. A8.00 and later).



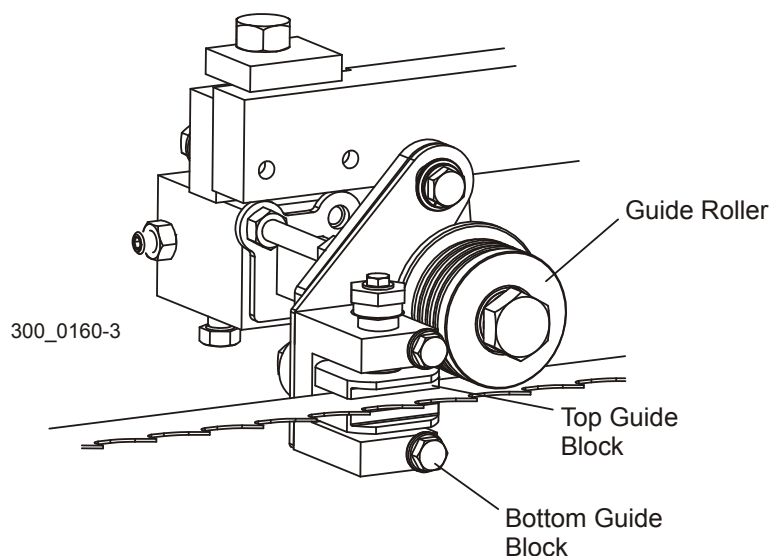
**WARNING!** Blade guide alignment is essential for optimal cutting performance, blade life and safety. Failure to check and maintain proper blade guide alignment will result in stress cracks forming in the blade. These cracks will lead to premature blade breakage. If the blade breaks during operation and the blade has multiple stress cracks, the blade could shatter into several pieces and escape from the protective guards of the sawmill. Small blade pieces projected into the area around the sawmill creates a safety hazard for the operator and any bystanders surrounding the mill.

**WARNING!** DO NOT use blades with stress cracks. Blades with stress cracks can shatter causing bodily injury and/or machine damage.

### 7.2.1 Blade Guide Adjustment Overview

Proper blade guide alignment is critical to optimum machine performance. It is important to understand and follow the procedures in this section to properly align the blade guides.

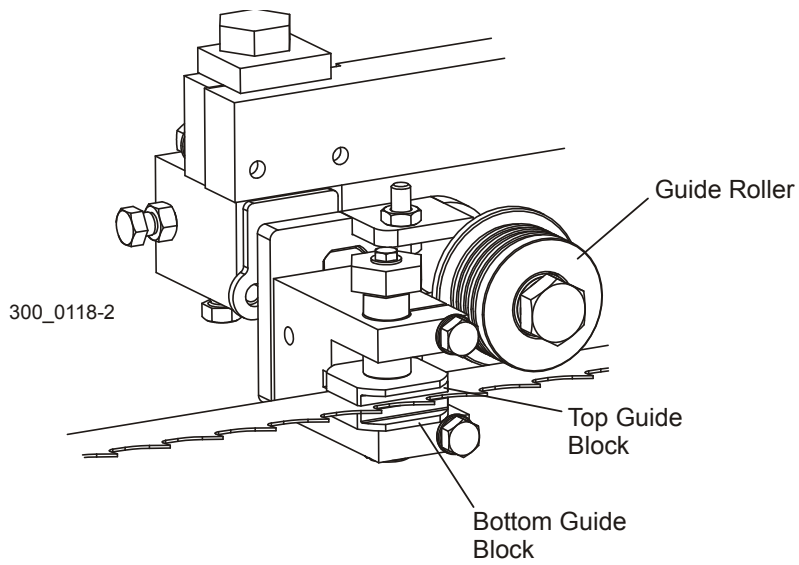
**See Figure 7-7.** The major components of the blade guide assemblies are the top and bottom guide blocks and guide roller.



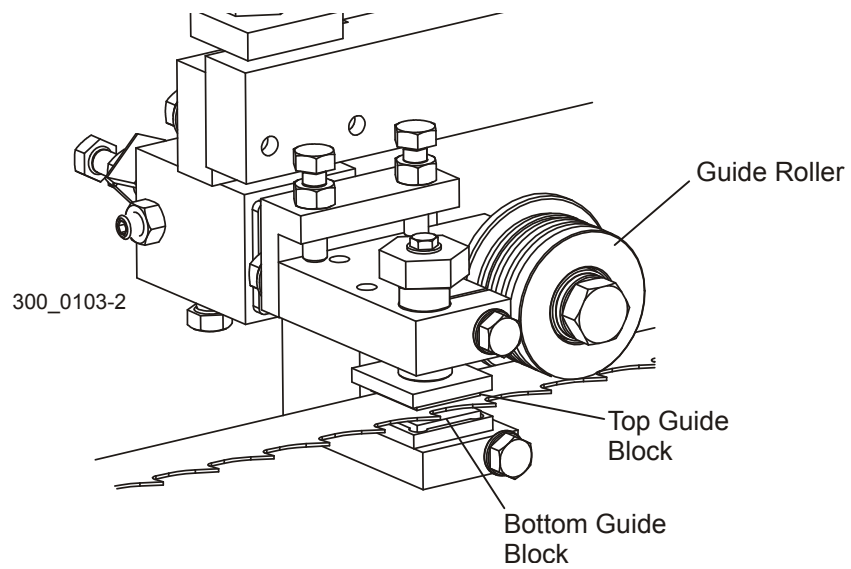
**FIG. 7-7 LT300 REV. B3.01 AND WM3000/WM3500 REV. B4.01 - B5.01**

# 7 Alignment

## Blade Guide Adjustment Overview

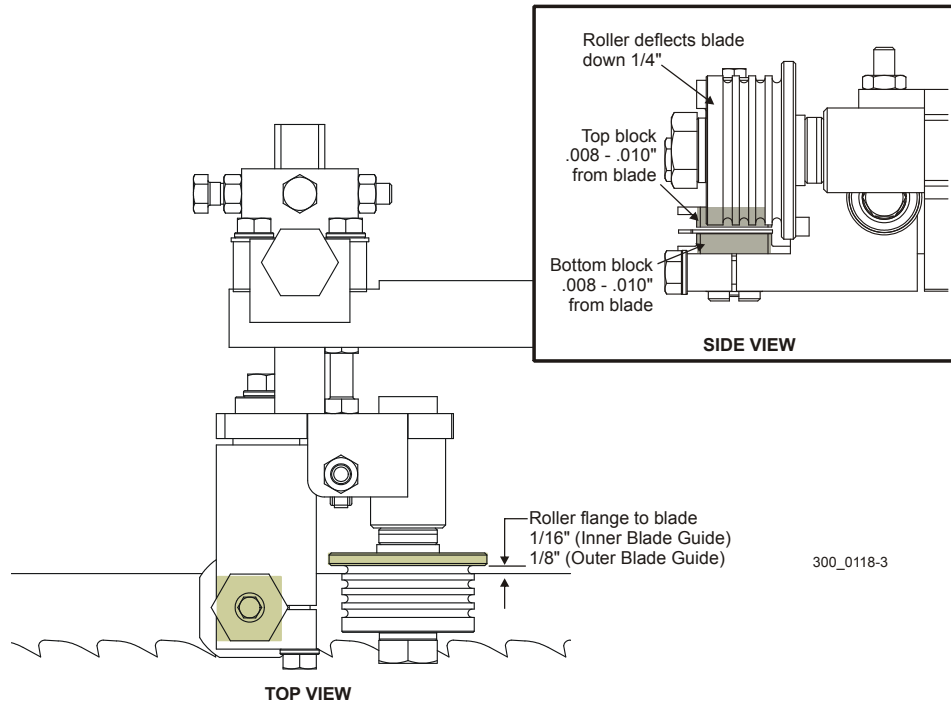


**FIG. 7-7 REV. A9.04 - B3.00**



**FIG. 7-7 REV. A1.00 - A9.03**

**See Figure 7-8.** The objective to aligning the blades guides is to properly position the guide blocks and guide roller in relation to the blade. The roller should deflect the blade down 1/4". The flange of the roller should be positioned 1/16" from the back edge of the blade at the inner guide assembly and 1/8" from the blade at the outer guide assembly. The blocks should be adjusted to .008" - .010" from the blade.



**FIG. 7-8**

## 7 Alignment

### Blade Guide Adjustment Overview

See Figure 7-9. LT300/WM3000 Rev. B5.02+: Adjustment bolts are provided to obtain the proper blade guide alignment. The various blade guide adjustments are described below.

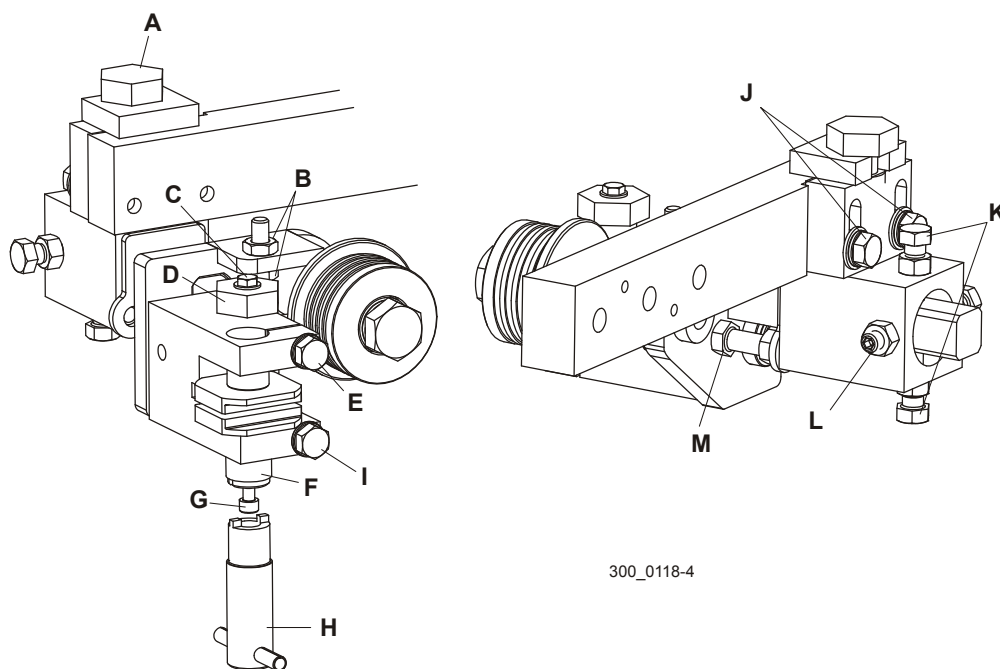


FIG. 7-9

<b>A</b>	<b>Vertical Adjustment Bolt</b> - Use to adjust entire blade guide assembly up or down. Use a 1" wrench to turn the bolt. Turning clockwise will raise assembly; counterclockwise will lower assembly. This adjustment may be made without loosening clamp bolts (K) if assembly is properly lubricated.
<b>B</b>	<b>Block Pivot Adjustment Jam Nuts</b> - Use a 1/2" wrench to adjust jam nuts up or down to block assembly so blocks are parallel to the blade.
<b>C</b>	<b>Top Guide Block Bolt</b> - Use to disassemble top guide block. Use 5/16" nut driver to remove bolt.
<b>D</b>	<b>Top Guide Block Adjustment Bolt</b> - Use to raise or lower top guide block. Use a 1/2" wrench to loosen clamp bolt (E). Turn adjustment bolt by hand counterclockwise to raise top guide block; clockwise to lower top guide block.
<b>E</b>	<b>Top Guide Block Clamp Bolt</b> - Loosen with 1/2" wrench to allow adjustment of top guide block adjustment bolt (D).
<b>F</b>	<b>Bottom Block Adjustment Bolt</b> - Use to adjust bottom guide block. Loosen clamp bolt (I) and use supplied tool (H) to turn bolt.
<b>G</b>	<b>Bottom Guide Block Bolt</b> - Use to disassemble bottom guide block. Use 5/32" hex wrench to remove bolt.
<b>H</b>	<b>Bottom Block Adjustment Tool</b> - Use to adjust bottom guide block bolt (F).

<b>I</b>	<b>Bottom Guide Block Clamp Bolt</b> - Loosen with 1/2" wrench to allow adjustment of bottom guide block adjustment bolt (F).
<b>J</b>	<b>Blade Guide Assembly Clamp Bolts</b> - Used to secure vertical adjustment of entire blade guide assembly. Loosening these bolts is not normally required when adjusting the vertical adjustment bolt (A). Make sure these bolts are tight after making vertical adjustment.
<b>K</b>	<b>Vertical Tilt Adjustment Bolts</b> - Use the bolts to tilt the entire blade so it is parallel to the bed rails. Use a 1/2" wrench to loosen the jam nuts. Adjust the bolts up to tilt the blade down; adjust bolts down to tilt blade up. Retighten the jam nuts.
<b>L</b>	<b>Blade Guide Clamp Bolt</b> - Holds blade guide assembly securely in mounting bracket. Loosen this bolt and one tilt bolt (L) to allow movement of the blade guide assembly in or out. Use a 1/2" wrench to loosen the jam nut and adjust the clamp bolt.
<b>M</b>	<b>Blade Guide Stop Bolt</b> - Provides a stop to prevent the guide assembly from getting pushed back during operation. Use a 9/16" wrench to loosen the jam nut and adjust the bolt until it touches the end of the blade guide shaft after adjusting blade guide assembly in/out. Retighten the jam nut.

## 7 Alignment

### Blade Guide Adjustment Overview

See Figure 7-10. Rev. B3.01 - B5.01: Adjustment bolts are provided to obtain the proper blade guide alignment. The various blade guide adjustments are described below.

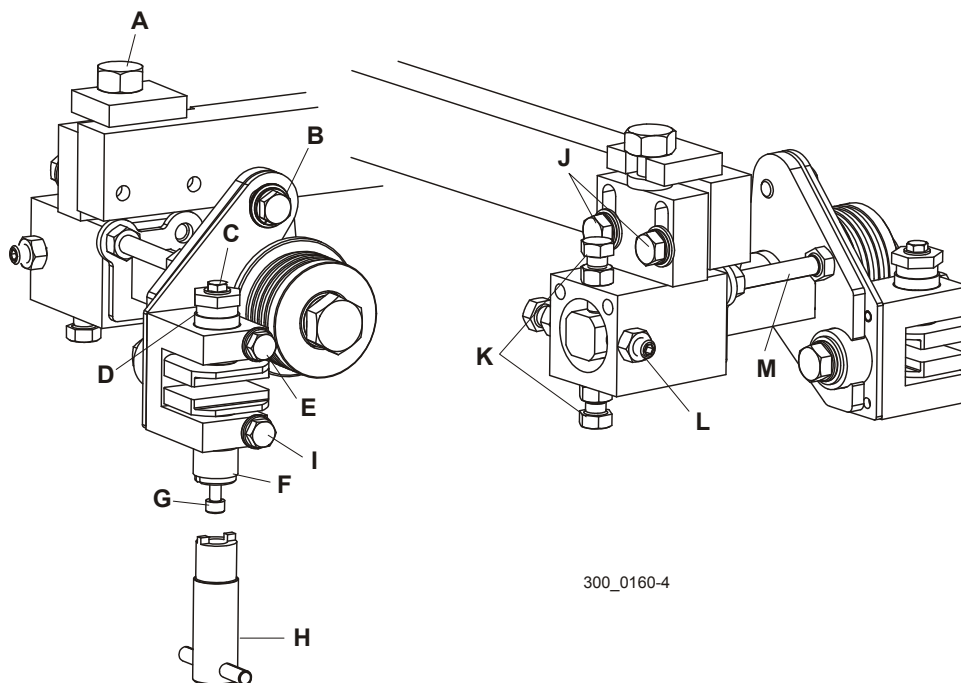


FIG. 7-10

<b>A</b>	<b>Vertical Adjustment Bolt</b> - Use to adjust entire blade guide assembly up or down. Use a 1" wrench to turn the bolt. Turning clockwise will raise assembly; counterclockwise will lower assembly. This adjustment may be made without loosening clamp bolts (K) if assembly is properly lubricated.
<b>B</b>	<b>Block Pivot Adjustment Bolt</b> - Use a 1/2" wrench to loosen bolt and pivot block assembly so blocks are parallel to the blade.
<b>C</b>	<b>Top Guide Block Bolt</b> - Use to disassemble top guide block. Use 5/16" nut driver to remove bolt.
<b>D</b>	<b>Top Guide Block Adjustment Bolt</b> - Use to raise or lower top guide block. Use a 1/2" wrench to loosen clamp bolt (E). Turn adjustment bolt by hand counterclockwise to raise top guide block; clockwise to lower top guide block.
<b>E</b>	<b>Top Guide Block Clamp Bolt</b> - Loosen with 1/2" wrench to allow adjustment of top guide block adjustment bolt (D).
<b>F</b>	<b>Bottom Block Adjustment Bolt</b> - Use to adjust bottom guide block. Loosen clamp bolt (I) and use supplied tool (H) to turn bolt.
<b>G</b>	<b>Bottom Guide Block Bolt</b> - Use to disassemble bottom guide block. Use 5/32" hex wrench to remove bolt.
<b>H</b>	<b>Bottom Block Adjustment Tool</b> - Use to adjust bottom guide block bolt (F).
<b>I</b>	<b>Bottom Guide Block Clamp Bolt</b> - Loosen with 1/2" wrench to allow adjustment of bottom guide block adjustment bolt (F).



<b>J</b>	<b>Blade Guide Assembly Clamp Bolts</b> - Used to secure vertical adjustment of entire blade guide assembly. Loosening these bolts is not normally required when adjusting the vertical adjustment bolt (A). Make sure these bolts are tight after making vertical adjustment.
<b>K</b>	<b>Vertical Tilt Adjustment Bolts</b> - Use the bolts to tilt the entire blade so it is parallel to the bed rails. Use a 1/2" wrench to loosen the jam nuts. Adjust the bolts up to tilt the blade down; adjust bolts down to tilt blade up. Retighten the jam nuts.
<b>L</b>	<b>Blade Guide Clamp Bolt</b> - Holds blade guide assembly securely in mounting bracket. Loosen this bolt and one tilt bolt (L) to allow movement of the blade guide assembly in or out. Use a 1/2" wrench to loosen the jam nut and adjust the clamp bolt.
<b>M</b>	<b>Blade Guide Stop Bolt</b> - Provides a stop to prevent the guide assembly from getting pushed back during operation. Use a 9/16" wrench to loosen the jam nut and adjust the bolt until it touches the end of the blade guide shaft after adjusting blade guide assembly in/out. Retighten the jam nut.

# 7 Alignment

## Blade Guide Adjustment Overview

See Figure 7-11. Rev. A9.04 - B3.00: Adjustment bolts are provided to obtain the proper blade guide alignment. The various blade guide adjustments are described below.

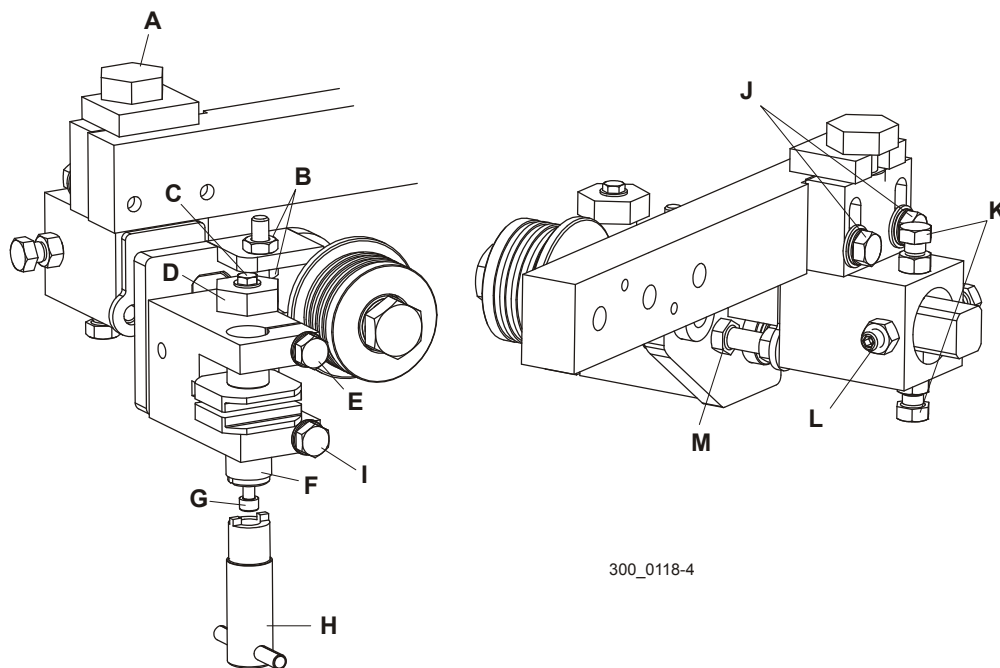


FIG. 7-11

<b>A</b>	<b>Vertical Adjustment Bolt</b> - Use to adjust entire blade guide assembly up or down. Use a 1" wrench to turn the bolt. Turning clockwise will raise assembly; counterclockwise will lower assembly. This adjustment may be made without loosening clamp bolts (K) if assembly is properly lubricated.
<b>B</b>	<b>Block Pivot Adjustment Jam Nuts</b> - Use a 1/2" wrench to adjust jam nuts up or down to block assembly so blocks are parallel to the blade.
<b>C</b>	<b>Top Guide Block Bolt</b> - Use to disassemble top guide block. Use 5/16" nut driver to remove bolt.
<b>D</b>	<b>Top Guide Block Adjustment Bolt</b> - Use to raise or lower top guide block. Use a 1/2" wrench to loosen clamp bolt (E). Turn adjustment bolt by hand counterclockwise to raise top guide block; clockwise to lower top guide block.
<b>E</b>	<b>Top Guide Block Clamp Bolt</b> - Loosen with 1/2" wrench to allow adjustment of top guide block adjustment bolt (D).
<b>F</b>	<b>Bottom Block Adjustment Bolt</b> - Use to adjust bottom guide block. Loosen clamp bolt (I) and use supplied tool (H) to turn bolt.
<b>G</b>	<b>Bottom Guide Block Bolt</b> - Use to disassemble bottom guide block. Use 5/32" hex wrench to remove bolt.
<b>H</b>	<b>Bottom Block Adjustment Tool</b> - Use to adjust bottom guide block bolt (F).
<b>I</b>	<b>Bottom Guide Block Clamp Bolt</b> - Loosen with 1/2" wrench to allow adjustment of bottom guide block adjustment bolt (F).

<b>J</b>	<b>Blade Guide Assembly Clamp Bolts</b> - Used to secure vertical adjustment of entire blade guide assembly. Loosening these bolts is not normally required when adjusting the vertical adjustment bolt (A). Make sure these bolts are tight after making vertical adjustment.
<b>K</b>	<b>Vertical Tilt Adjustment Bolts</b> - Use the bolts to tilt the entire blade so it is parallel to the bed rails. Use a 1/2" wrench to loosen the jam nuts. Adjust the bolts up to tilt the blade down; adjust bolts down to tilt blade up. Retighten the jam nuts.
<b>L</b>	<b>Blade Guide Clamp Bolt</b> - Holds blade guide assembly securely in mounting bracket. Loosen this bolt and one tilt bolt (L) to allow movement of the blade guide assembly in or out. Use a 1/2" wrench to loosen the jam nut and adjust the clamp bolt.
<b>M</b>	<b>Blade Guide Stop Bolt</b> - Provides a stop to prevent the guide assembly from getting pushed back during operation. Use a 9/16" wrench to loosen the jam nut and adjust the bolt until it touches the end of the blade guide shaft after adjusting blade guide assembly in/out. Retighten the jam nut.

## 7 Alignment

### Blade Guide Adjustment Overview

See Figure 7-12. Rev. A1.00 - A9.03: Adjustment bolts are provided to obtain the proper blade guide alignment. The various blade guide adjustments are described below.

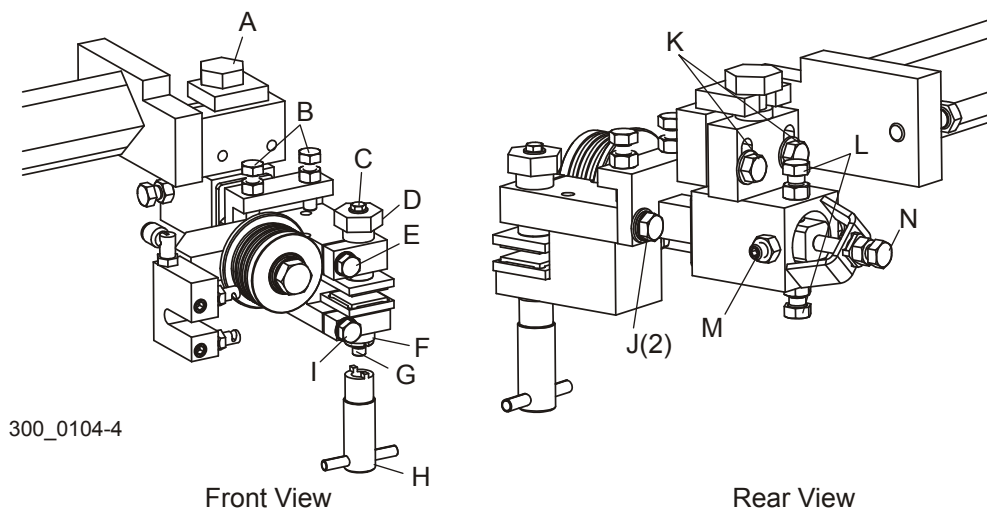


FIG. 7-12

<b>A</b>	<b>Vertical Adjustment Bolt</b> - Use to adjust entire blade guide assembly up or down. Use a 1" wrench to turn the bolt. Turning clockwise will raise assembly; counterclockwise will lower assembly. This adjustment may be made without loosening clamp bolts (K) if assembly is properly lubricated.
<b>B</b>	<b>Guide Tilt Bolts</b> - Use to adjust the bolts to tilt the blade guides so the guide blocks are parallel to the blade. Loosen clamp bolts (J), but leave them snug. To adjust each bolt, use a 1/2" wrench to loosen the jam nut, adjust the bolt and retighten the jam nut. Retighten clamp bolts (J).
<b>C</b>	<b>Top Guide Block Bolt</b> - Use to disassemble top guide block. Use 5/16" nut driver to remove bolt.
<b>D</b>	<b>Top Guide Block Adjustment Bolt</b> - Use to raise or lower top guide block. Use a 1/2" wrench to loosen clamp bolt (E) and turn by hand. Turn adjustment bolt by hand counterclockwise to raise top guide block; clockwise to lower top guide block.
<b>E</b>	<b>Top Guide Block Clamp Bolt</b> - Loosen with 1/2" wrench to allow adjustment of top guide block adjustment bolt (D).
<b>F</b>	<b>Bottom Block Adjustment Bolt</b> - Use to adjust bottom guide block. Loosen clamp bolt (I) and use supplied tool (H) to turn bolt.
<b>G</b>	<b>Bottom Guide Block Bolt</b> - Use to disassemble bottom guide block. Use 5/32" hex wrench to remove bolt.
<b>H</b>	<b>Bottom Block Adjustment Tool</b> - Use to adjust bottom guide block bolt (F).
<b>I</b>	<b>Bottom Guide Block Clamp Bolt</b> - Loosen with 1/2" wrench to allow adjustment of bottom guide block adjustment bolt (F).
<b>J</b>	<b>Guide Block Clamp Bolts</b> - Loosen both bolts but leave snug with 1/2" wrench to allow adjustment of guide tilt bolts (B).

<b>K</b>	<b>Blade Guide Assembly Clamp Bolts</b> - Used to secure vertical adjustment of entire blade guide assembly. Loosening these bolts is not normally required when adjusting the vertical adjustment bolt (A). Make sure these bolts are tight after making vertical adjustment.
<b>L</b>	<b>Vertical Tilt Adjustment Bolts</b> - Use the bolts to tilt the entire blade so it is parallel to the bed rails. Use a 1/2" wrench to loosen the jam nuts. Adjust the bolts up to tilt the blade down; adjust bolts down to tilt blade up. Retighten the jam nuts.
<b>M</b>	<b>Blade Guide Clamp Bolt</b> - Holds blade guide assembly securely in mounting bracket. Loosen this bolt and one tilt bolt (L) to allow movement of the blade guide assembly in or out. Use a 1/2" wrench to loosen the jam nut and adjust the clamp bolt.
<b>N</b>	<b>Blade Guide Stop Bolt</b> - Provides a stop to prevent the guide assembly from getting pushed back during operation. Use a 1/2" wrench to loosen the jam nut and adjust the bolt until it touches the end of the blade guide shaft after adjusting blade guide assembly in/out. Retighten the jam nut.

### 7.2.2 Preparing For Blade Guide Alignment

Recommended tools:

- Wrenches: 1/2", 9/16", 3/4", & 1"
  - 5/16" Nut Driver
  - 5/32" Hex Wrench
  - Blade Guide Alignment Blocks
  - Bottom Guide Block Adjustment Tool
  - Blade Guide Alignment Tool
  - Blade Guide Arm Alignment Tool
  - Flashlight
1. Remove the blade and replace the blade wheel belts. New blade wheel belts are required to perform the complete alignment procedure.
  2. Blow sawdust off of the blade guide assemblies. Remove sawdust from the blade housings.
  3. Remove the blade guide assemblies.
 

**NOTE:** To remove the blade guide assemblies and maintain the tilt adjustments, only loosen one side screw and the top screw. Leaving the other side screw and bottom screw in position will insure you will return the rollers to their original tilt adjustment.
  4. Adjust the outer blade guide arm in or out until the outer blade guide is approximately 24" from the inner blade guide.

# 7

## Alignment

### Blade Wheel Vertical Alignment

5. Install a new blade and apply the appropriate tension ([See Section 4.7](#)).
6. Close the blade housing covers and make sure all persons are clear of the saw head.
7. Start the engine (or motor).
8. Engage the blade, rotating the blade until the blade positions itself on the wheels.



**WARNING!** Do not spin the blade wheels by hand. Spinning the blade wheels by hand may result in serious injury.

9. Disengage the blade. Turn the engine off and remove the key.

#### 7.2.3 Blade Wheel Vertical Alignment

1. Use the blade guide alignment tool to check the vertical alignment of each blade wheel. Attach the tool to the blade near the inner blade guide. Be sure the tool does not rest on a tooth or burr, and is lying flat on the bottom of the blade.

See Figure 7-13.

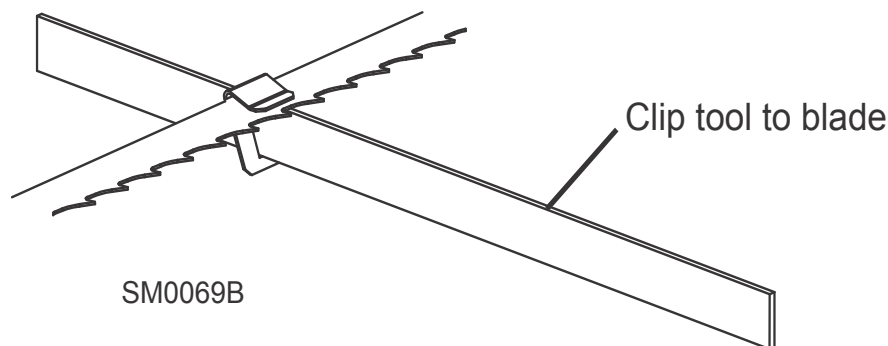
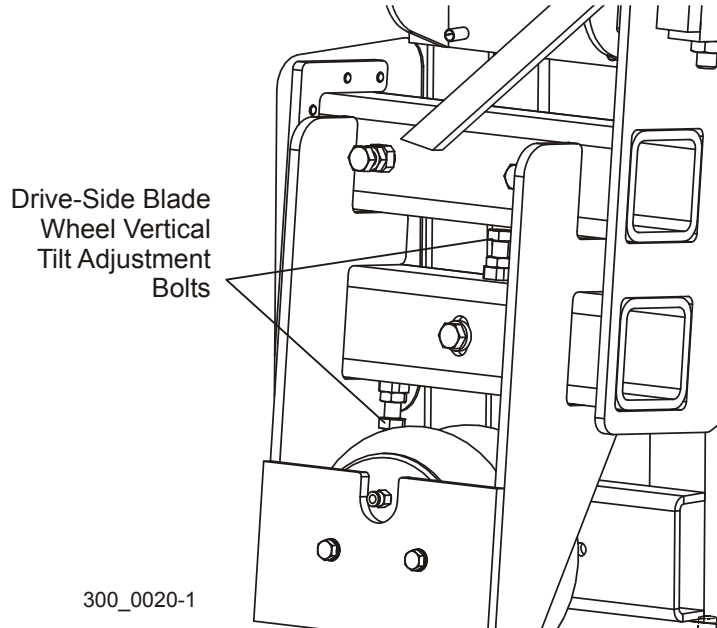


FIG. 7-13

2. Move the saw carriage so the front end of the tool is positioned over the first bed rail. Measure from the bottom of the tool to the top surface of the bed rail.
3. Move the saw carriage so the rear of the tool is positioned over the bed rail. Again, measure from the bottom of the tool to the bed rail.
4. If the two measurements are not equal within 1/16", adjust the vertical tilt of the drive-side blade wheel. Remove the drive-side cover and locate the vertical tilt adjustment bolts. Loosen the jam nuts on each bolt. Adjust the bolts down to tilt the blade up. Adjust the bolts up to tilt the blade down. Retighten the jam nuts and recheck the tilt of the blade with the blade guide alignment tool.

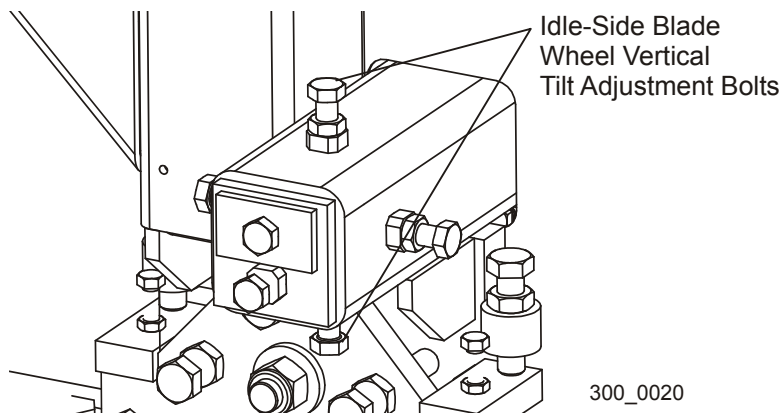
See Figure 7-14.



**FIG. 7-14**

5. Remove the tool from the blade and reattach it near the outer blade guide assembly.
6. Measure from the tool to the bed rail at both ends of the tool. If the measurements at the front and rear ends of the tool are not equal within 1/16", adjust the vertical tilt of the idle-side blade wheel. Loosen the jam nuts on each bolt. Adjust the bolts down to tilt the blade up. Adjust the bolts up to tilt the blade down. Retighten the jam nuts and recheck the tilt of the blade with the blade guide alignment tool.

See Figure 7-15.



**FIG. 7-15**

# 7 Alignment

## Blade Guide Arm Alignment

### 7.2.4 Blade Guide Arm Alignment

Adjust the blade guide arm all the way in toward the inner blade guide assembly.

**See Figure 7-16.** Attach the blade guide arm alignment tool to the blade guide arm, near the outer blade housing. Measure the distance from the back edge of the blade to the tool. Move the tool to the end of the arm near the blade guide. Measure again from the back edge of the blade to the tool. The two measurements at each end of the arm should be the same within 1/32". To adjust the horizontal tilt of the arm parallel to the blade, adjust the bolts (A & B) on the blade guide arm mounting plate. Loosen the jam nuts. Adjust bolt (A) out and bolt (B) in to move the arm away from the blade. Adjust bolt (B) out and bolt (A) in to move the arm toward the blade. Recheck the distance from the back edge of the blade to the tool at both ends of the arm. Readjust if necessary. Tighten the jam nuts.

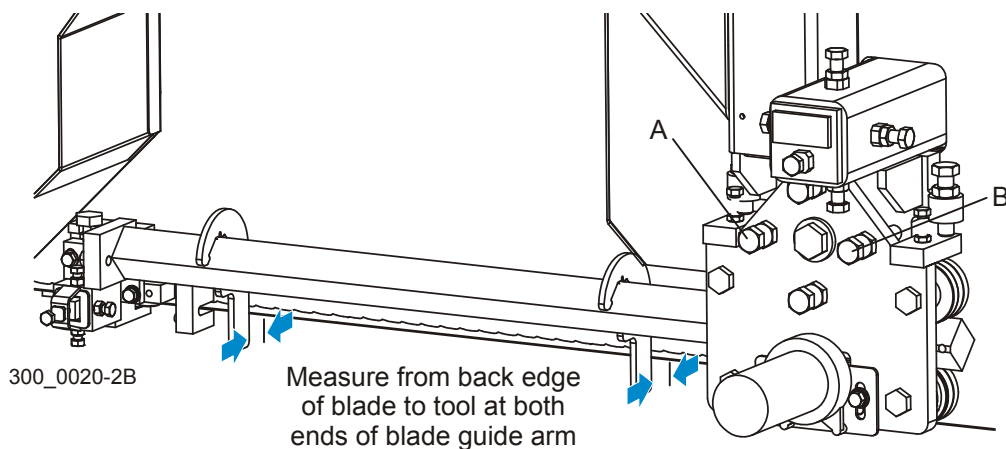
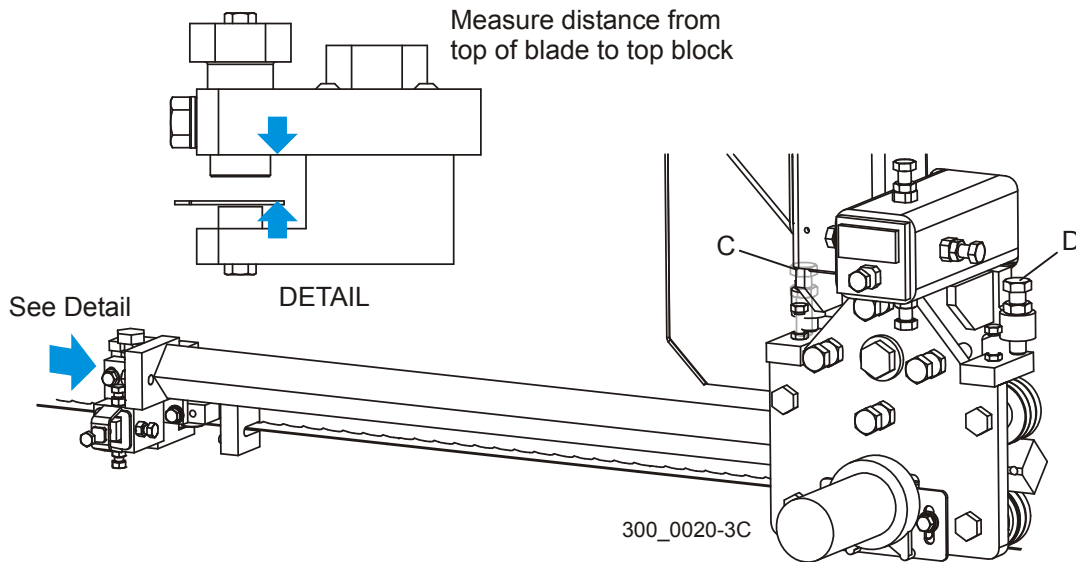


FIG. 7-16



**See Figure 7-17.** With the blade guide arm adjusted in near the inner blade guide, measure the distance from the top of the blade to the top blade guide block. Adjust the blade guide arm all the way out and measure again. If the two measurements are not equal with  $1/32$ ", adjust the vertical tilt of the blade guide arm. To adjust the vertical tilt of the arm, adjust the bolts (C & D) on the blade guide arm mounting plate. Loosen the jam nuts. Adjust bolt (C) up and bolt (D) down to tilt the arm up. Adjust bolt (D) up and bolt (C) in to move the arm toward the blade. Recheck the distance from the blade to the top block at both ends of the arm. Readjust if necessary. Tighten the jam nuts.



**FIG. 7-17**

7.

### 7.2.5 Blade Guide Alignment

Each Wood-Mizer sawmill has two blade guide assemblies that help the blade maintain a straight cut. The two blade guide assemblies are positioned on the saw head to guide the blade on each side of the material being cut.

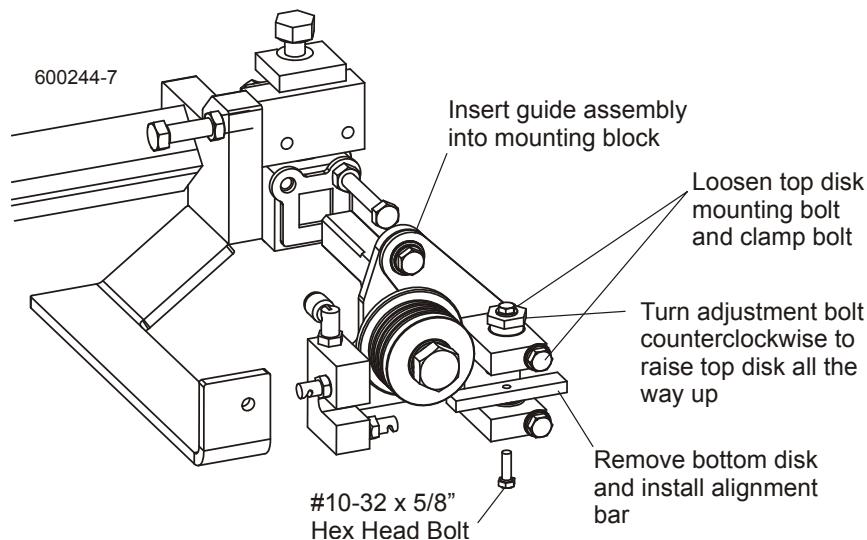
One blade guide assembly is mounted in a stationary position on the drive side of the saw head. This assembly is referred to as the "inner" blade guide assembly.

The other blade guide assembly is mounted on the idle side of the saw head. It is referred to as the "outer" assembly and is adjustable for various widths of materials to be processed.

**NOTE:** Before installing the blade guide assemblies, remove the blade guide adjusting screws and apply a lubricating oil such as 10W30 or Dexron III to each screw. This will prevent the screws and threaded holes from corroding and make screw adjustments easier.

1. Inspect the guide blocks and repair or replace as necessary. Remove the blade from the sawmill.

See Figure 7-6.



**FIG. 7-6**

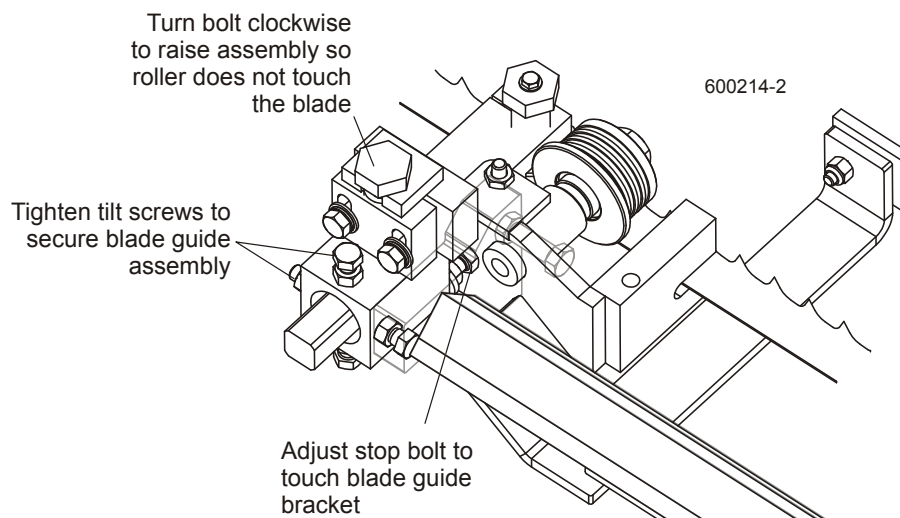
2. Loosen the top block clamp bolt and mounting bolt. Turn the adjustment bolt counterclockwise to raise the top block all the way up. Remove the bottom guide block from each blade guide assembly and install the provided alignment bar.
3. Install each blade guide assembly to the mounting blocks and push all the way back.

4. Install, tension and track a new blade. Adjust the outer blade guide assembly so the roller flange is 1/8" from the back of the blade. Adjust the inner blade guide assembly so the roller flange is 1/16" from the blade.

**See Figure 7-7.** Tighten the two previously-loosened tilt adjustment screws to secure the blade guide assembly. Turn the top adjustment bolt clockwise to raise the blade guide assembly so the roller does not contact the blade.

**NOTE:** Before adjusting the top bolt, unload pressure on the bolt by turning 1/2 turn in the opposite direction it was last adjusted.

**Rev. A9.04+:** With the roller flange positioned properly from the back of the blade, adjust the stop bolt so it touches the blade guide bracket.

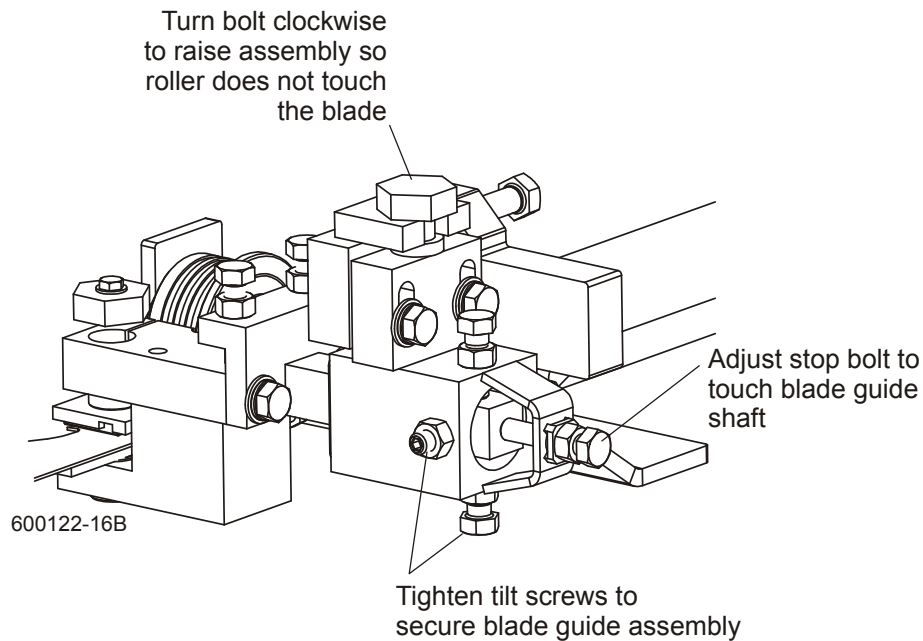


**FIG. 7-7**

## 7 Alignment

### Blade Guide Alignment

**Rev. A1.00 - A9.03:** With the roller flange positioned properly from the back of the blade, adjust the stop bolt so it touches the end of the blade guide mounting shaft.



**FIG. 7-7**

Adjust the blade guide assemblies so the rollers deflect the blade down 1/4"

5. Raise the saw head until the blade is 15" (375 mm) above a bed rail. Measure the actual distance with a tape from the top of the rail to the bottom of the blade.

See Figure 7-8.

Turn the top adjustment bolt counterclockwise to lower the assembly until the blade guide roller deflects the blade down until the bottom of the blade measures 14 3/4" (370 mm) from the bed rail.

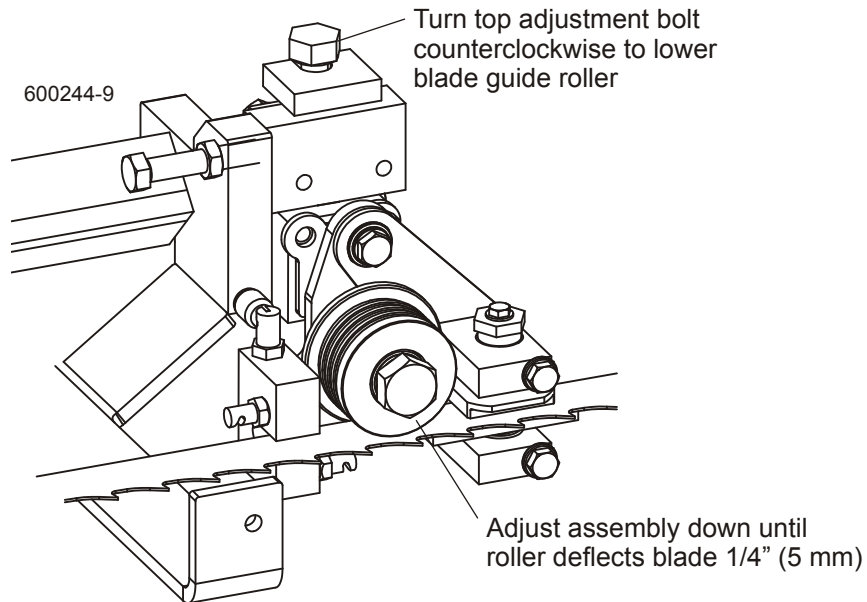


FIG. 7-8

**NOTE:** Before adjusting the top bolt, unload pressure on the bolt by turning 1/2 turn in the opposite direction it was last adjusted.

6. Repeat for the other blade guide.

# 7

## Alignment

### Blade Guide Alignment

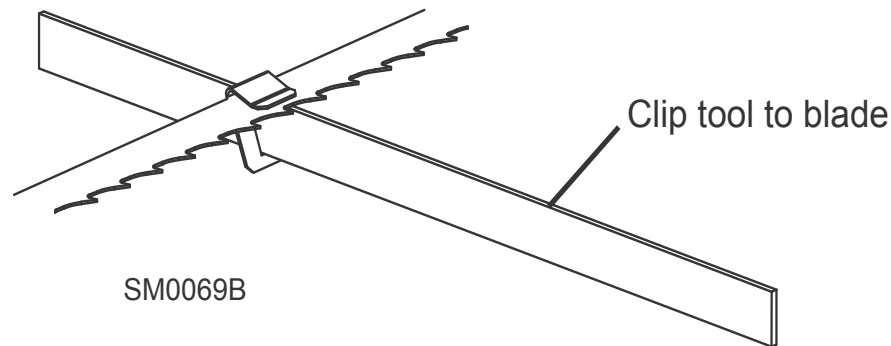
---

Check the blade guides are adjusted properly in the vertical plane. If the blade guides are tilted vertically, the blade will try to travel in the tilted direction.

A Blade Guide Alignment Tool (BGAT) is provided to help you measure the vertical tilt of the blade.

7. Open the adjustable blade guide arm 1/2" (15 mm) from full open.
8. Clamp the alignment tool on the blade. Position the tool close to the outer blade guide roller. Be sure the tool does not rest on a tooth or burr, and is lying flat on the blade.

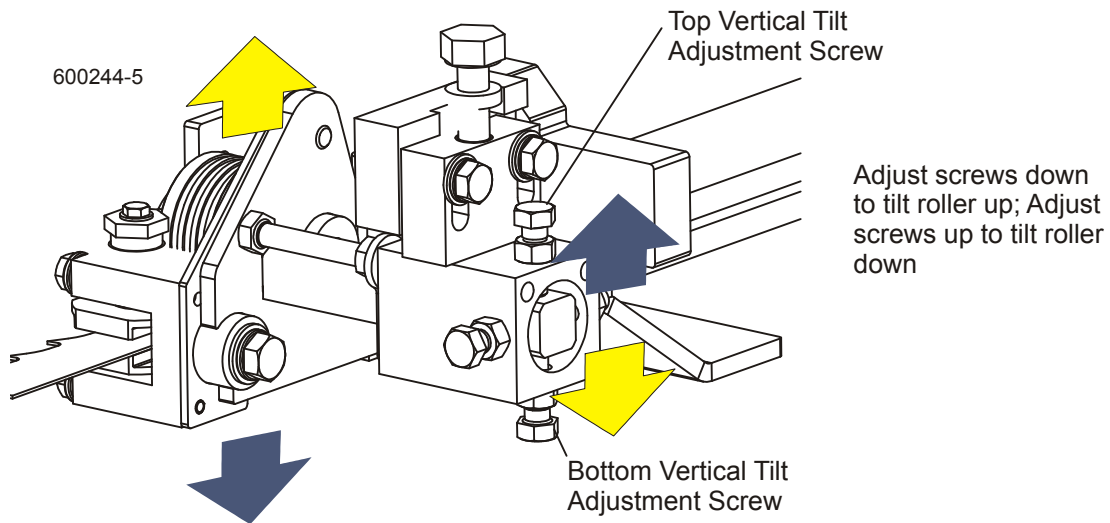
See Figure 7-9.



**FIG. 7-9**

9. Move the carriage so that the front end of the tool is positioned above the bed rail. Measure the distance from the bed rail to the bottom edge of the tool.
10. Move the carriage so that the back end of the tool is positioned above the bed rail. Measure the distance from the bed rail to the bottom edge of the tool.
11. If the measurement from the tool to the bed rail is not equal within 1/32" (.75 mm), adjust the vertical tilt of the outer blade guide roller.
12. Loosen one set screw at the side of the blade guide assembly.

**See Figure 7-10.** Loosen the jam nuts on the top and bottom vertical tilt adjustment screws. To tilt the roller up, loosen the bottom screw and tighten top screw. To tilt the roller down, loosen the top screw and tighten the bottom screw. Tighten the jam nuts and recheck the tilt of the blade.



**FIG. 7-10**

- 13.** Move the blade guide alignment tool close to the inner blade guide roller assembly and repeat the above steps. Adjust the vertical tilt of the inner blade guide if necessary.
- 14.** After adjusting the vertical tilt of the blade guides, recheck the blade deflection and adjust if necessary.

# 7

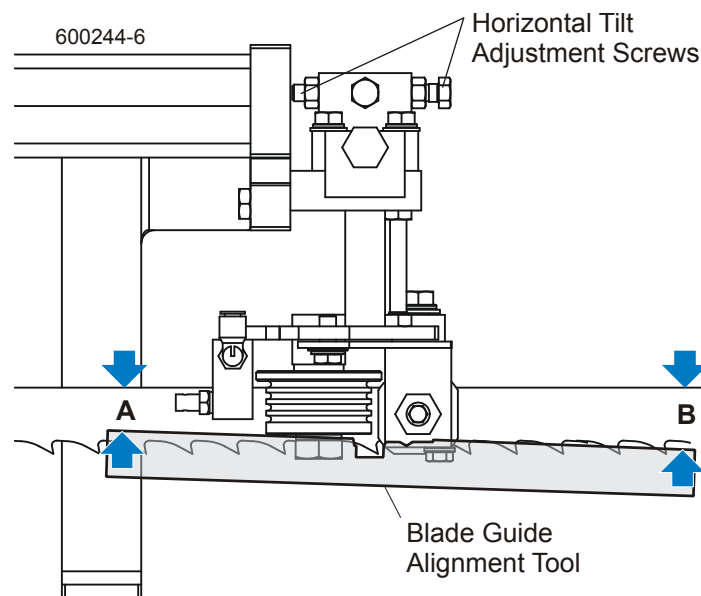
## Alignment

### Blade Guide Alignment

If the blade guides are tilted in the wrong direction horizontally, the back of the blade may contact the flange as the roller is spinning down, causing it to push the blade away from the guide roller.

15. Remove the blade guide alignment tool from the blade and adjust the blade guide arm halfway in.
16. Remove the clip from the blade guide alignment tool. Place the tool against the face of the outer blade guide roller.

See Figure 7-11.



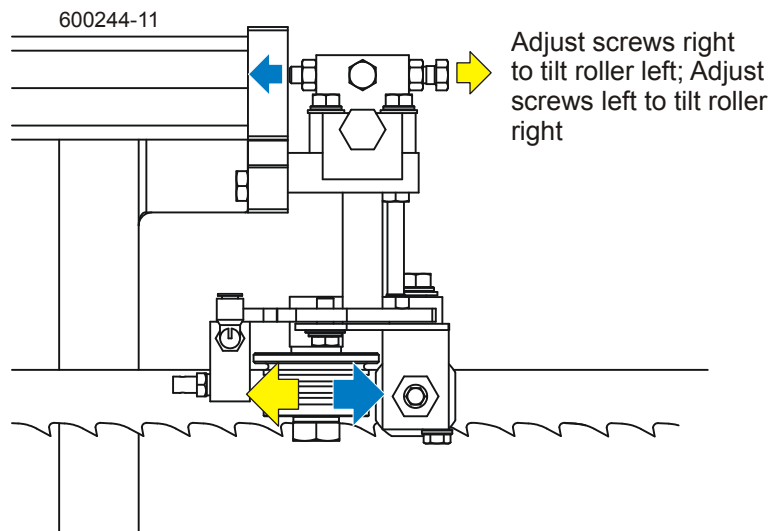
**FIG. 7-11**

17. Measure between the back edge of the blade and the tool at the end closest to the inner blade guide ("B").
18. Measure between the back edge of the blade and the other end of the tool ("A").

The roller should be tilted slightly to the left ('A' 1/8" [3 mm] less than 'B'  $\pm$ 1/8" [3 mm]).



**See Figure 7-12.** Loosen the jam nuts on the horizontal tilt adjustment screws. To tilt the roller left, loosen the right screw and tighten left screw. To tilt the roller right, loosen the left screw and tighten the right screw. Tighten the jam nuts and recheck the tilt of the blade.



**FIG. 7-12**

**19.** Repeat the above steps for the inner blade guide roller assembly.

**NOTE:** Once the blade guides have been adjusted, any cutting variances are most likely caused by the blade. [See Blade Handbook, Form #600.](#)

Each blade guide must be adjusted so the roller flange is the correct distance from the back edge of the blade. If the flange is too close to or too far from the blade, the sawmill will not cut accurately.

**HINT:** When adjusting blade guide spacing, loosen the top set screw and one side set screw only. This will ensure horizontal and vertical tilt adjustments are maintained when the adjustment screws are retightened.

**20.** Measure the distance between the flange on the inner blade guide roller to the back edge of the blade. This distance should measure 1/16" (1.5 mm). Adjust the roller back or forward if necessary.

# 7 Alignment

## Blade Guide Alignment

See Figure 7-13. Loosen the top and one side screw shown. Back the stop bolt out of the way if necessary. Tap the blade guide forward or backward until properly positioned. Retighten the screws and jam nuts. Adjust the stop bolt against the blade guide assembly.

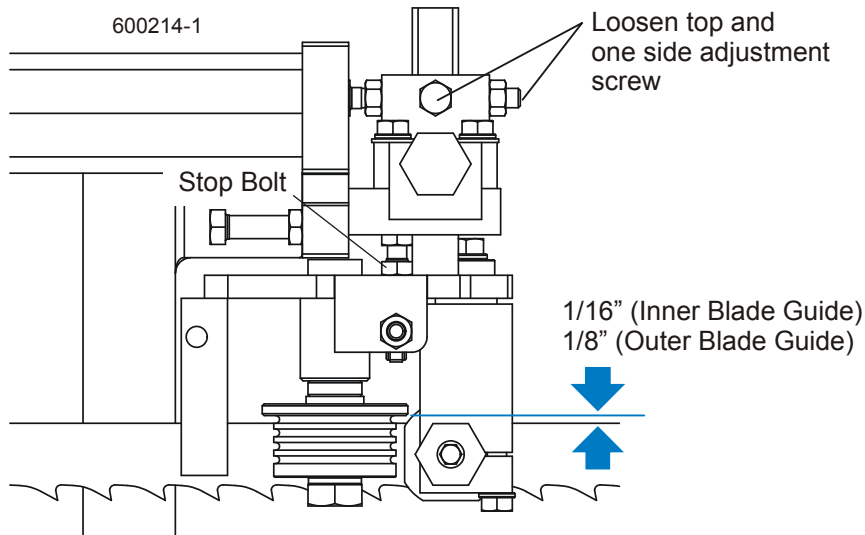


FIG. 7-13 REV. A9.04+

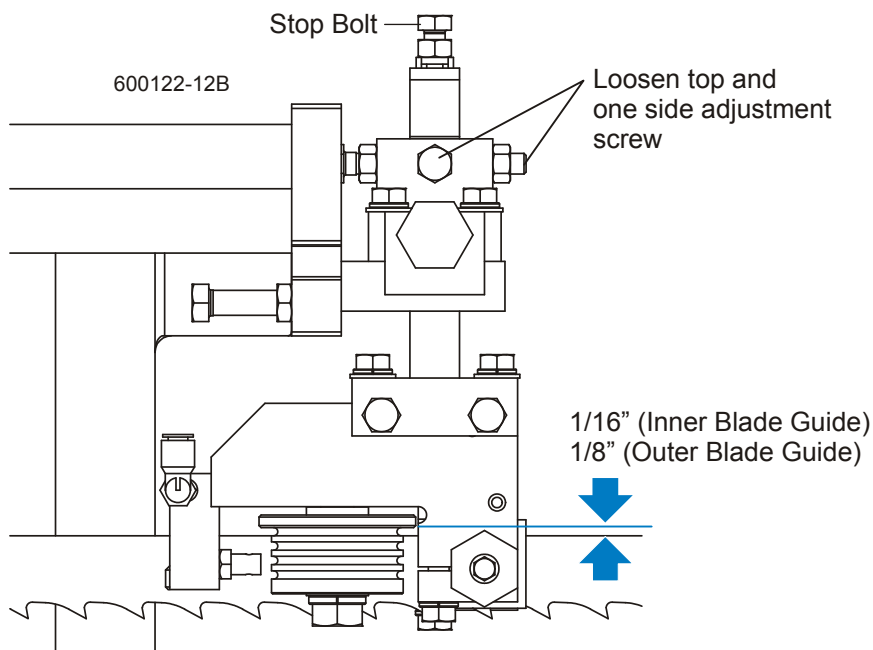


FIG. 7-13 REV. A1.00 - A9.03

21. Measure the distance between the flange on the outer blade guide roller to the back edge of the blade. This distance should measure 1/8" (3.0 mm). Adjust the roller back or forward if necessary.

Perform the following adjustments to make sure the blade guide assembly is parallel to the blade.

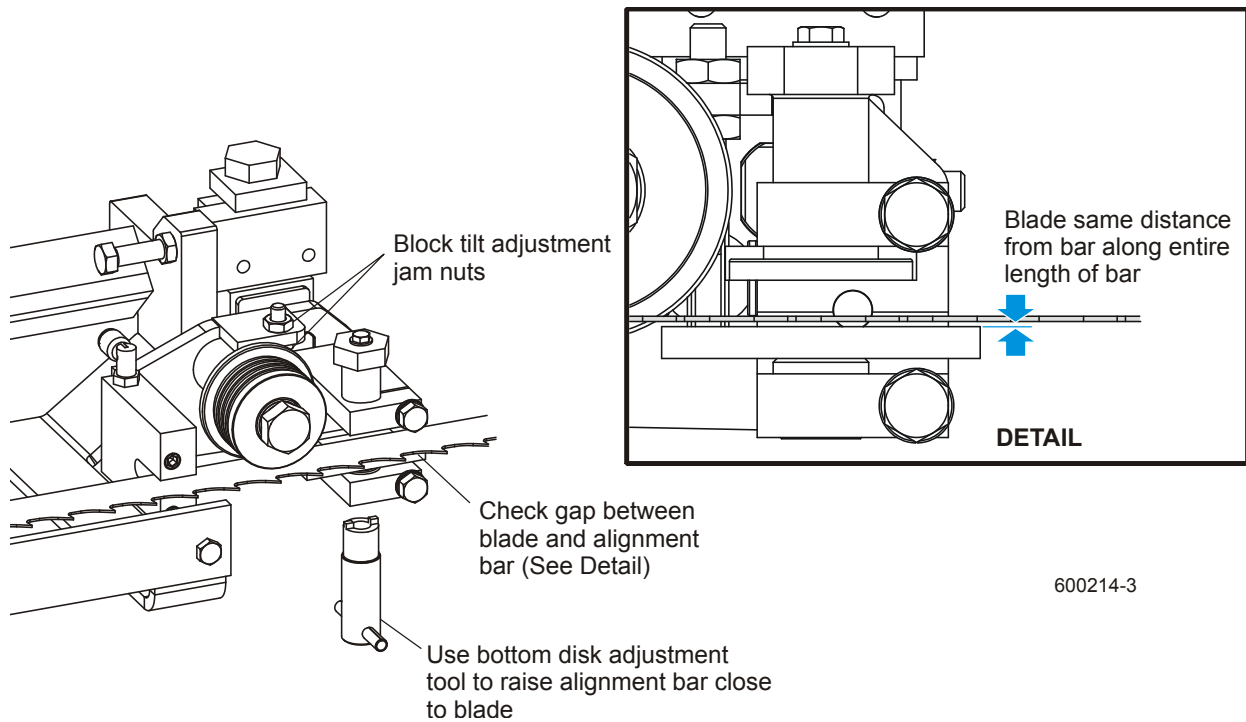
- 22.** Loosen the alignment bar mounting bolt. Use the provided bottom block adjustment tool to adjust the alignment bar up so the bar is close to, but not touching the bottom of the blade. Retighten the alignment bar mounting bolt
- 23.** Check that the gap from the alignment bar to the blade is the same along entire length of the bar. Shine a flashlight behind the blade guide assembly to help you see the gap between the bar and the blade.

# 7 Alignment

## Blade Guide Alignment

**LT300/WM3000 Rev B5.02+:** To adjust, turn the tilt adjustment jam nuts to pivot the block assembly until the alignment bar is parallel to the blade. Retighten the jam nuts. Repeat for the second blade guide assembly.

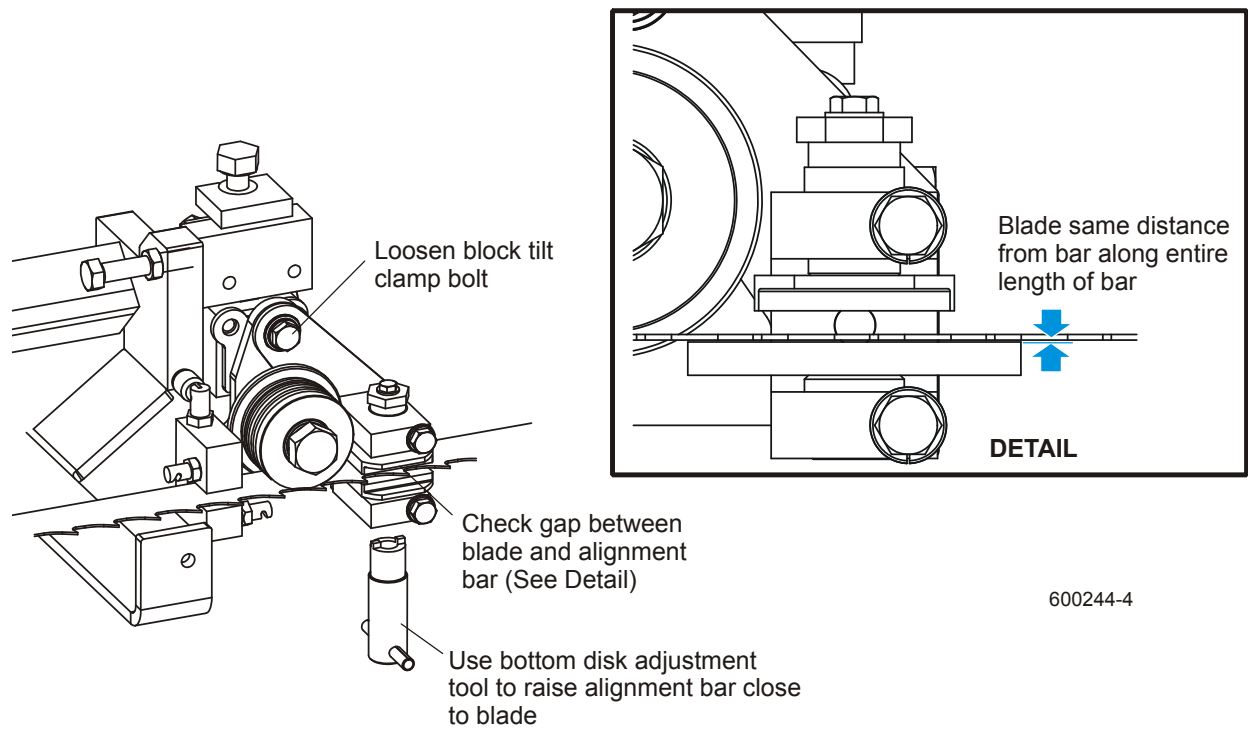
See Figure 7-14.



**FIG. 7-14**

**Rev. B3.01 - B5.01:** To adjust, loosen the block tilt clamp bolt to pivot the block assembly until the alignment bar is parallel to the blade. Retighten the clamp bolt. Repeat for the second blade guide assembly.

See Figure 7-15.



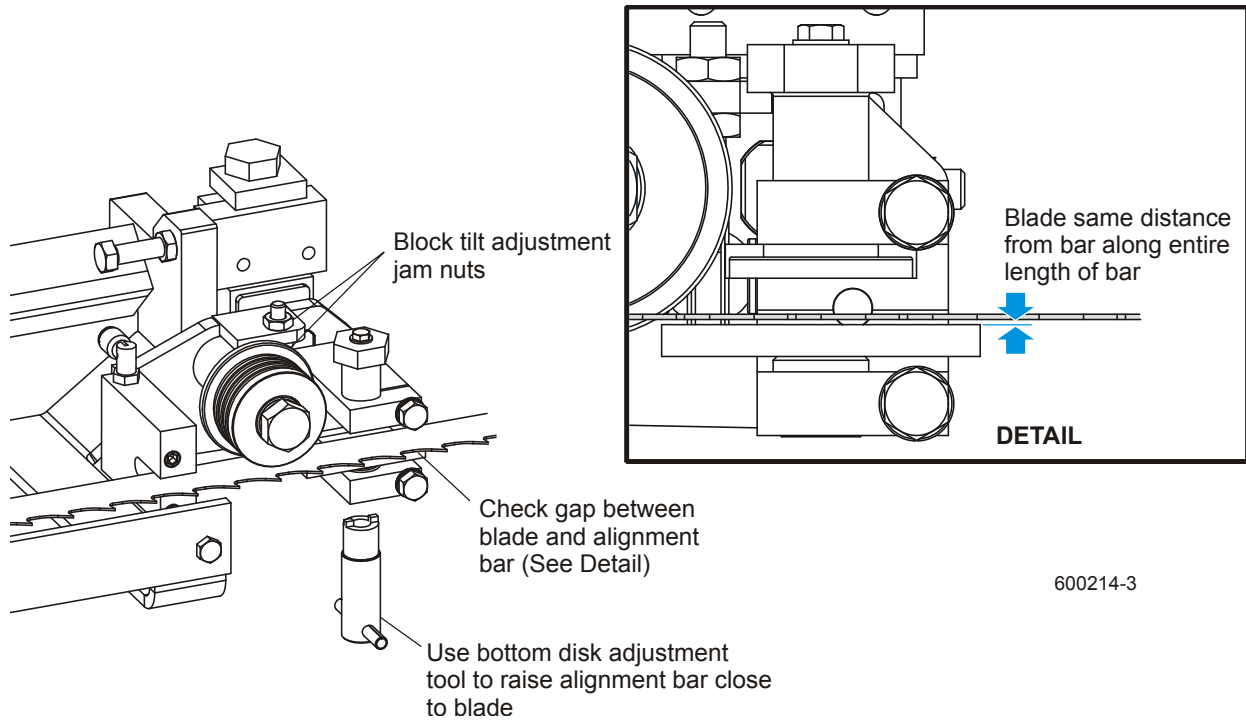
**FIG. 7-15**

# 7 Alignment

## Blade Guide Alignment

**Rev. A9.04 - B3.00:** To adjust, turn the tilt adjustment jam nuts to pivot the block assembly until the alignment bar is parallel to the blade. Retighten the jam nuts. Repeat for the second blade guide assembly.

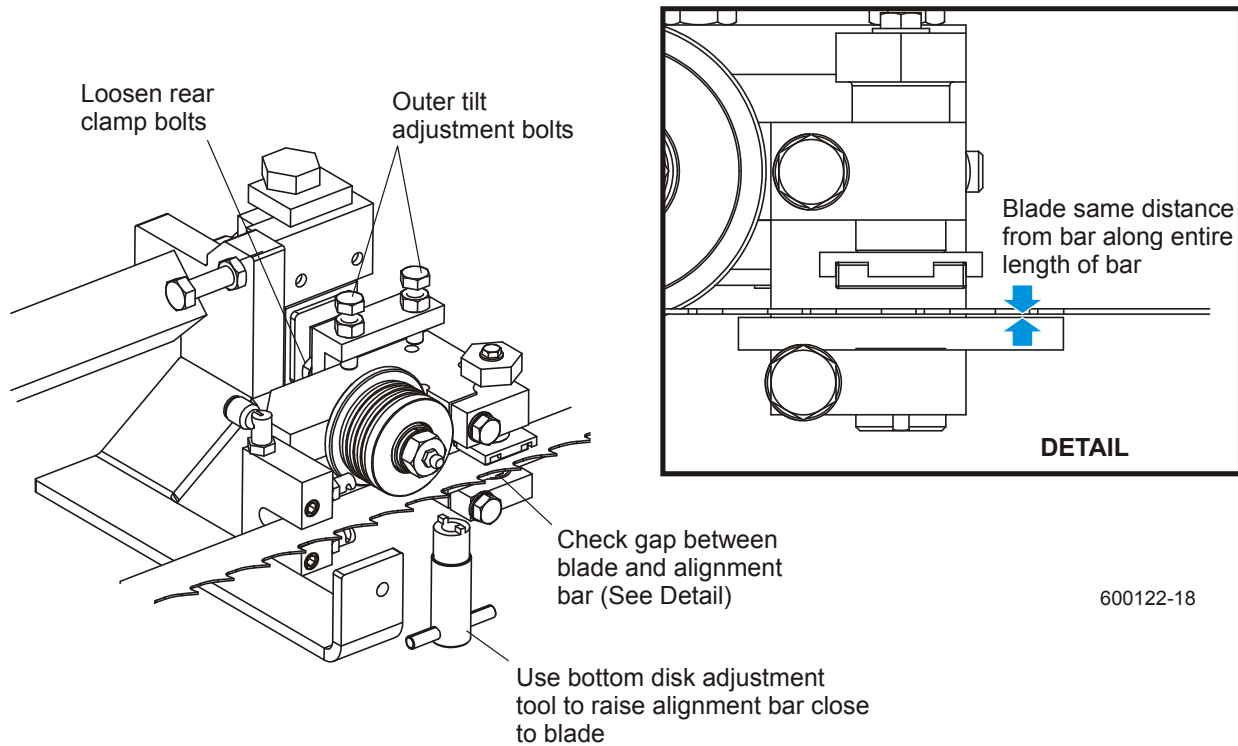
See Figure 7-16.



**FIG. 7-16**

**Rev. A1.00 - A9.03:** To adjust, loosen the rear clamp bolts, but leave snug. Determine which outer bolt to use to tilt the blade guide assembly as desired. Loosen the jam nut and turn the bolt until the alignment bar is parallel to the blade. Retighten the jam nut and clamp bolts. Repeat for the second blade guide assembly.

See Figure 7-17.



600122-18

**FIG. 7-17**

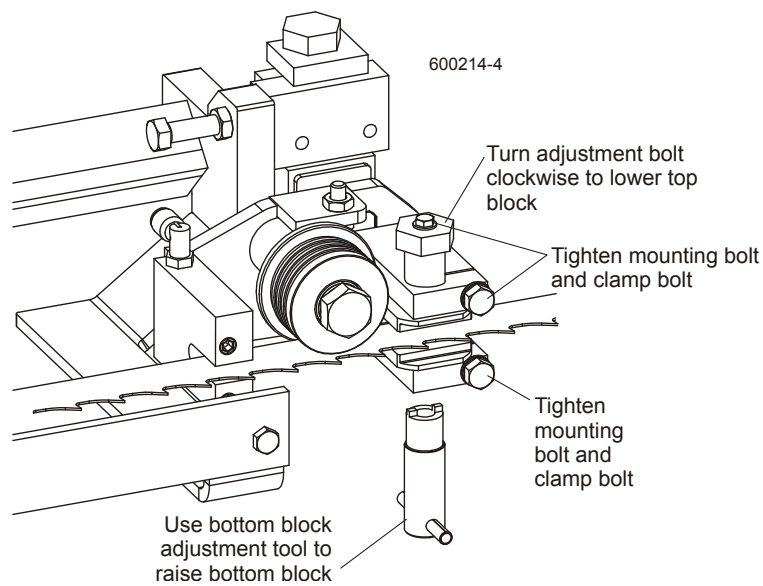
## 7 Alignment

### Blade Guide Alignment

Adjust the blade guide blocks the proper distance from the blade.

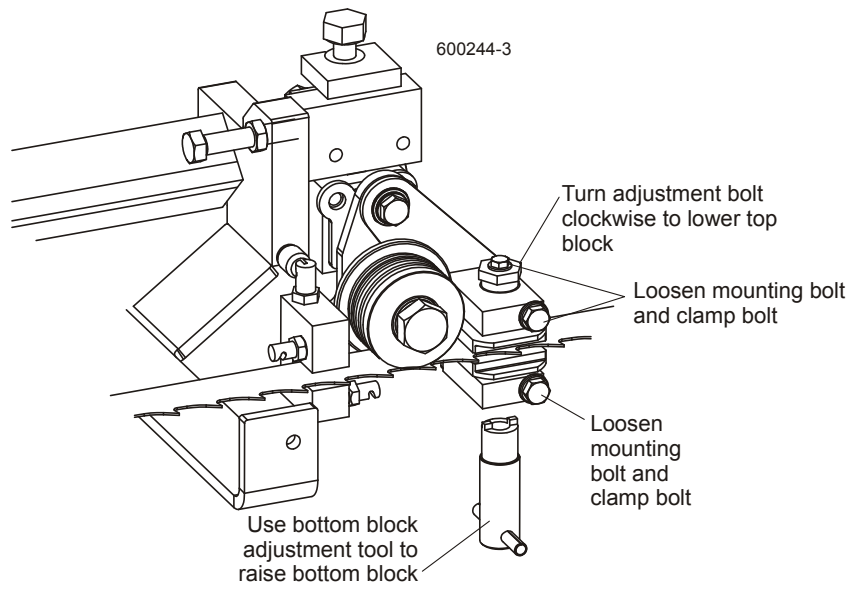
24. Remove the blade and remove the alignment bars from the blade guide assemblies. Install new or reconditioned bottom guide blocks to both blade guide assemblies (leave mounting bolts loose). Use the provided bottom block adjustment tool to lower the bottom block all the way down. Install, tension and track the blade.

See Figure 7-18.

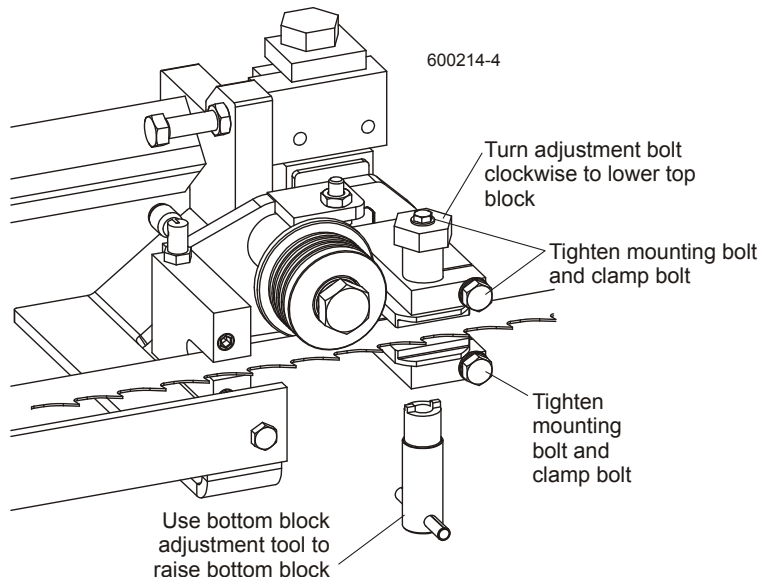


**FIG. 7-18**





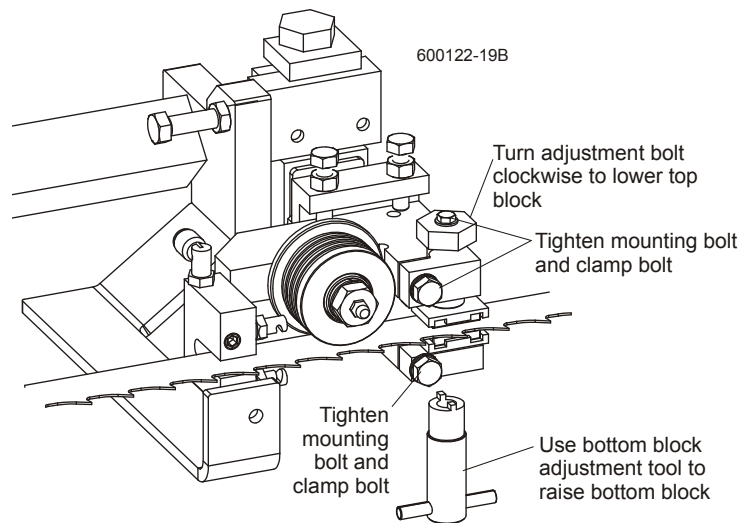
**FIG. 7-18 LT300 REV. B3.01 AND WM3000/WM3500 REV. B4.01 - B5.01**



**FIG. 7-18 REV. A9.04 - B3.00**

# 7 Alignment

## Blade Guide Alignment



**FIG. 7-18 REV. A1.00 - A9.03**

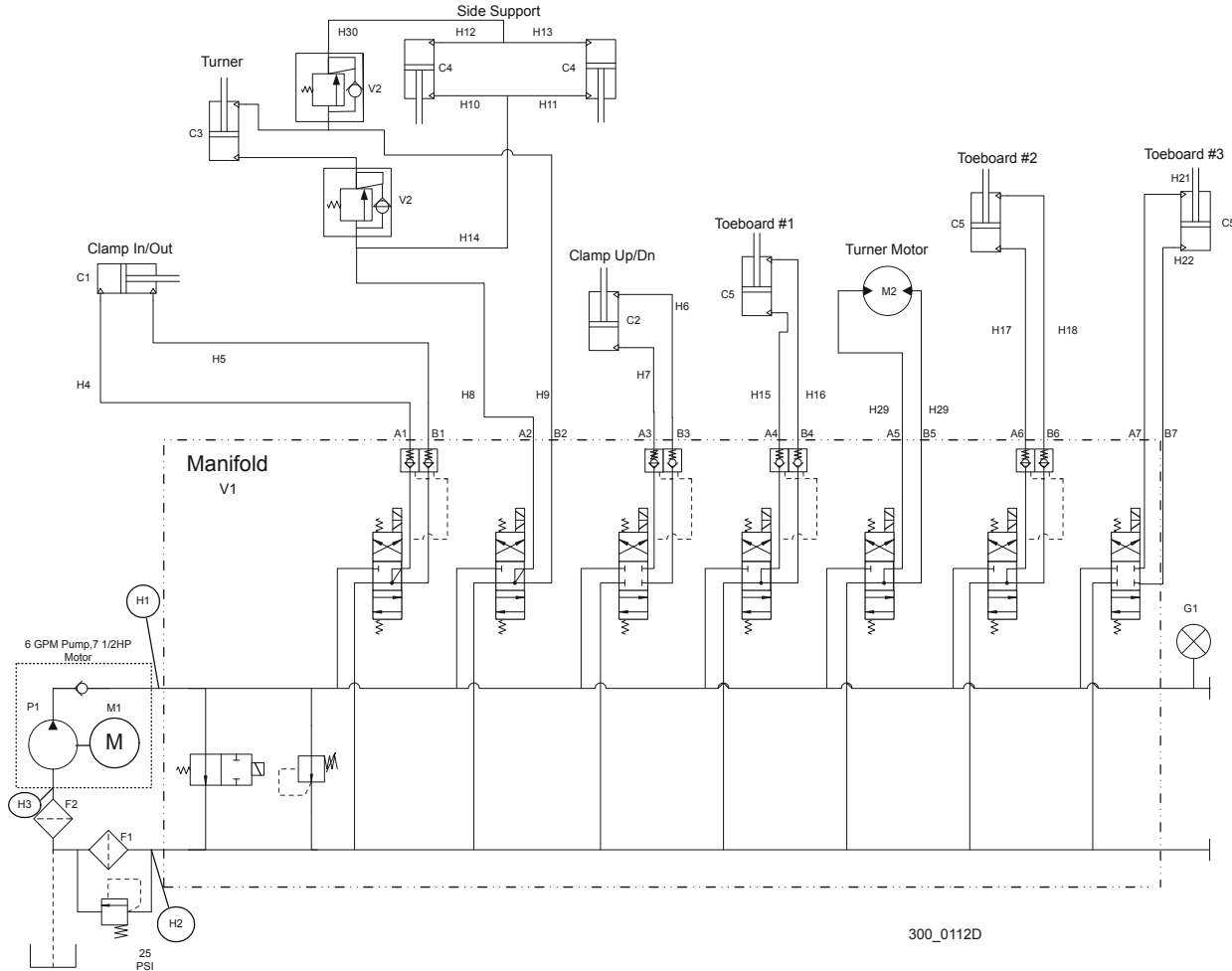
25. Use the bottom block adjustment tool to raise the bottom block to .008" - .010" from the blade. Use the provided shim to set the distance from the block to the blade. Tighten the bottom block mounting bolt and clamp bolt.
26. Turn the top block adjustment bolt clockwise to lower the top block to .008" - .010" from the blade (using the shim as a guide). Tighten the top block mounting bolt and clamp bolt.
27. After tightening the clamp bolt, recheck the distance from the top block to the blade and readjust if necessary.

# SECTION 8 HYDRAULIC INFORMATION

## 8.1 Hydraulic Schematics

LT300  
LT300-BX6

Rev. A9.00+  
Rev. B3.02+

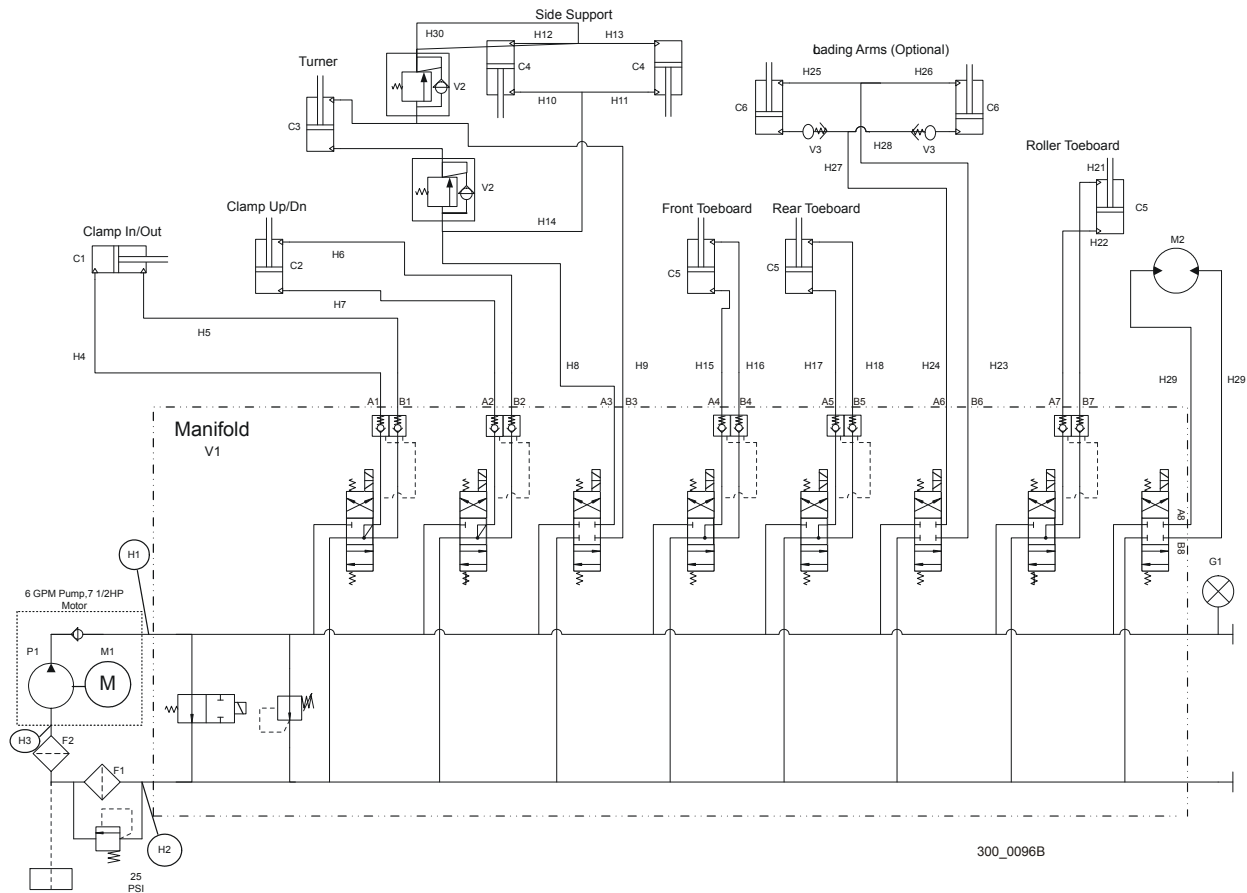


See Figure 8-1.

## 8.2 Hydraulic Schematic

LT300

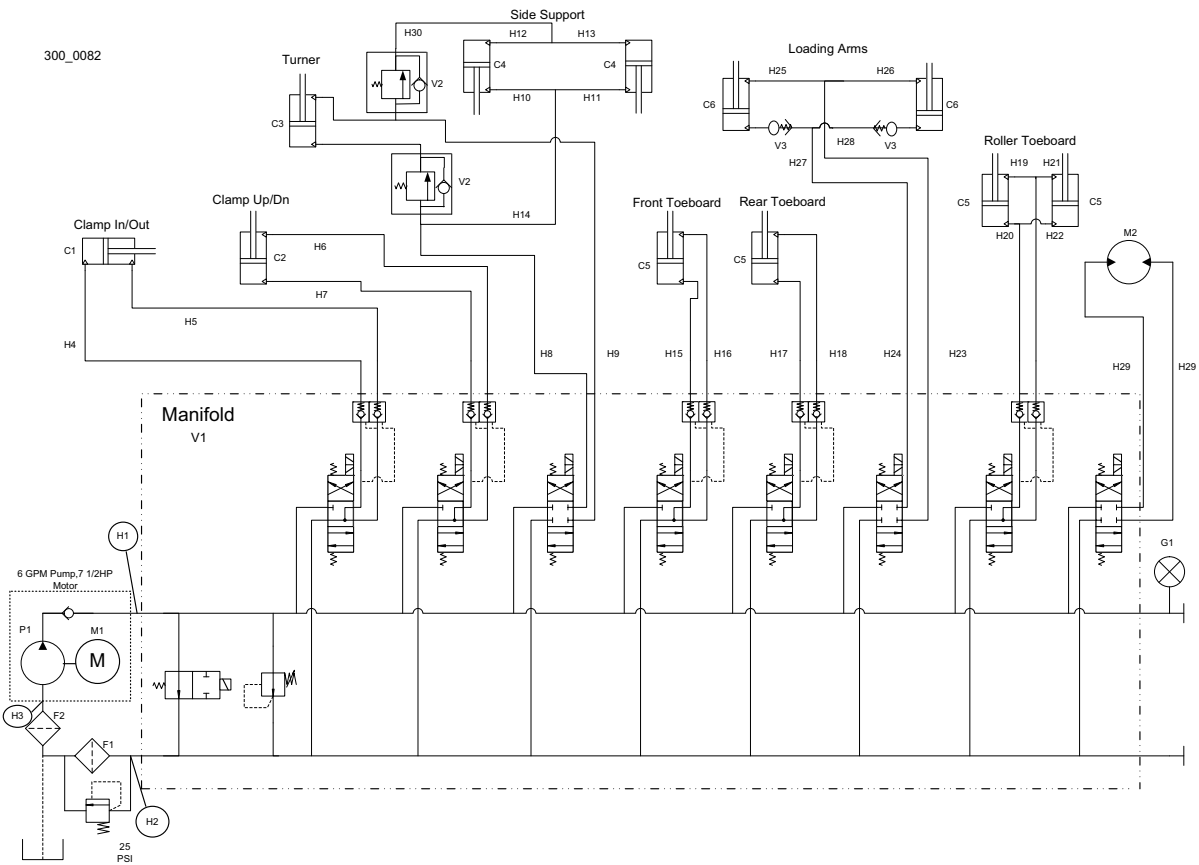
Rev. A7.00 - A8.00



### 8.3 Hydraulic Schematic

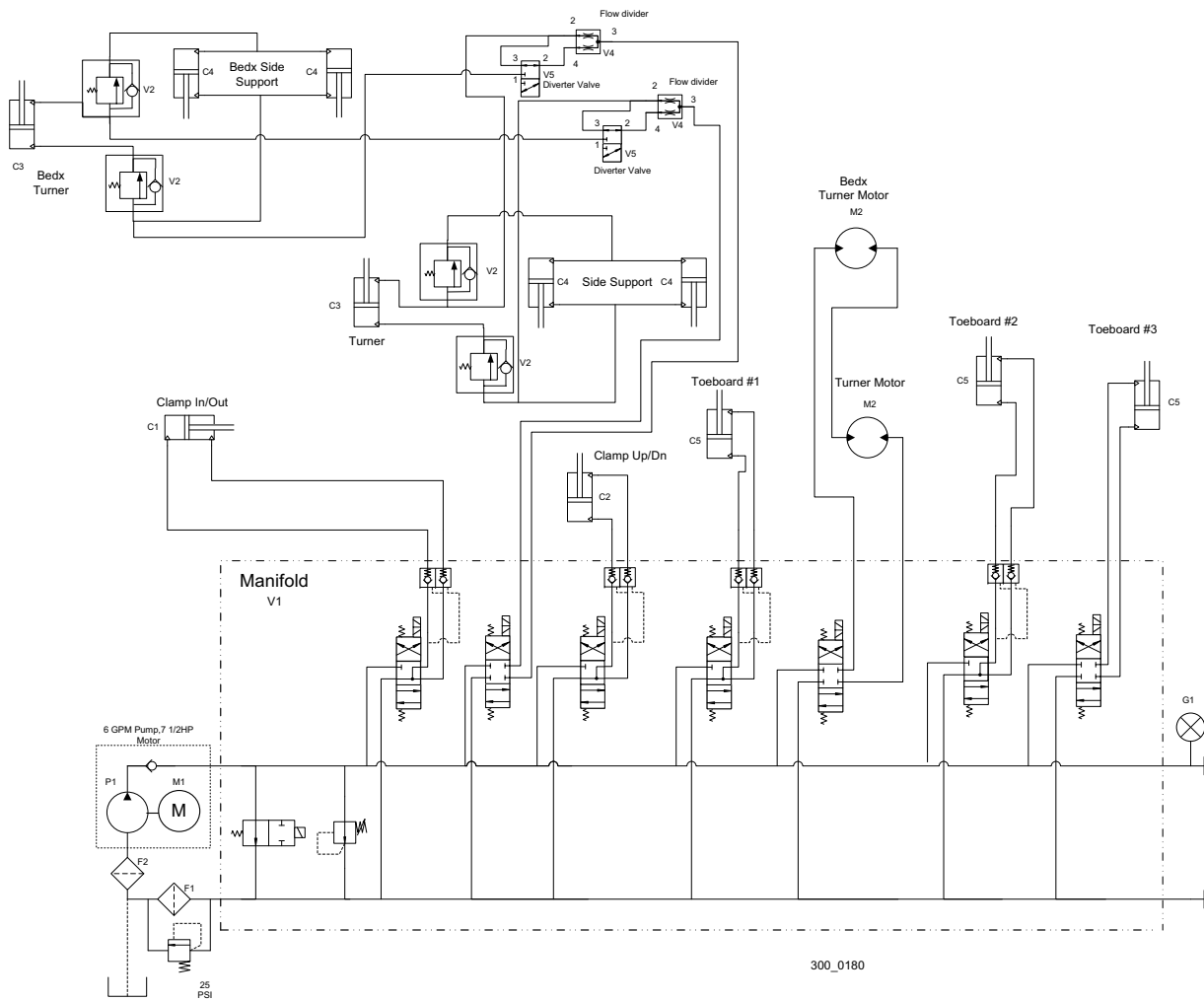
LT300

Rev. A1.00 - A6.01



## 8.4 Hydraulic Schematic

*LT300-BX10*



## 8.5 Hydraulic Hoses

LT300

Rev. A7.00+

COLOR	LENGTH "A" LT300	LENGTH "A" LT300-BX6	LENGTH "A" LT300-BX10	DESCRIPTION	Part No. LT300	Part No. LT300-BX6	Part No. LT300-BX10
				GROMMET, 2 1/2" DIAMETER RUBBER		085614	
				GROMMET, 4 3/8" X 10" OVAL	N/A	085759	085759
<b>1/4" Hydraulic Hoses</b>							
Yellow	158"	230"	278"	1/4" TOE BOARD #1 TOP	036566		
Grey	158"	230"	278"	1/4" TOE BOARD #1 BASE	036566		
Purple	247"	319"	367"	1/4" TOE BOARD #2 TOP	036067		
Black	243"	315"	363"	1/4" TOE BOARD #2 BASE	036567		
Red	283"	355"	411"	1/4" TOE BOARD #3 TOP	036568		
Blue	281"	353"	409"	1/4" TOE BOARD #3 BASE	036569		
Yellow	256"	328"	376"	1/4" CLAMP UP/DOWN BASE	036560		
Green	268"	340"	388"	1/4" CLAMP UP/DOWN TOP	036066		
<b>3/8" Hydraulic Hoses</b>							
Pink	224"	296"	344"	3/8" LOG TURNER IN/OUT BASE	036561		
Plain	224"	296"	344"	3/8" LOG TURNER IN/OUT TOP	036561		
White	220"	292"	340"	3/8" CLAMP IN/OUT TOP	036563		
Orange	211"	283"	331"	3/8" CLAMP IN/OUT BASE	036069		
Plain		23"		3/8" SIDE SUPPORT BRANCH 'T' (TURNER)		036073	
Plain			23"	3/8" BX SIDE SUPPORT BRANCH 'T' (TURNER)			036073
Plain		29"		3/8" SIDE SUPPORT BRANCH 'T' (FRONT TOP)		036074	
Plain			29"	3/8" BX SIDE SUPPT BRANCH 'T' (FRONT TOP)			036074
Plain		39"		3/8" SIDE SUPPORT BRANCH 'T' (REAR TOP)		036075	
Plain		39"		3/8" SIDE SUPPORT BRANCH 'T' (FRONT BASE)		036075	
Plain			39"	3/8" BX SIDE SUPPT BRANCH 'T' (REAR TOP)			036075
Plain			39"	3/8" BX SIDE SUPPT BRANCH 'T' (FRONT BASE)			036075
Plain		43"		3/8" SIDE SUPPORT BRANCH 'T' (REAR BASE)		036077	
Plain			43"	3/8" BX SIDE SUPPORT BRANCH			036077
Pink			43"	3/8" BX MAIN VALVE TO FLOW DIVIDER #3			036077
Plain			48"	3/8" BX MAIN VALVE TO FLOW DIVIDER #3			
Pink			26"	3/8" BX FLOW DIVIDER #4 TO DIVERter #2			
Plain			26"	3/8" BX FLOW DIVIDER #4 TO DIVERter #2			
Pink			6"	3/8" BX FLOW DIVIDER #2 TO T FITTING			
Plain			6"	3/8" BX FLOW DIVIDER #2 TO T FITTING			
Pink			18"	3/8" BX DIVERter #3 TO T FITTING			
Plain			18"	3/8" BX DIVERter #3 TO T FITTING			
Pink			160"	3/8" BX TURNER UP/DOWN BASE			
Plain			160"	3/8" BX TURNER UP/DOWN TOP			

## 8

## Hydraulic Information

## Hydraulic Hoses

3/8" Hydraulic Hoses (Loading Arm Option) <sup>2</sup>					
Blue	230"	302"	3/8" LOADING ARM TOP		036565
Red	230"	302"	3/8" LOADING ARM BOTTOM		036565
Green	88"		3/8" LOADING ARM BRANCH TOP		036080
Green	56"		3/8" LOADING ARM BRANCH TOP		036081
Yellow	86"		3/8" LOADING ARM BRANCH BASE		036082
Yellow	54"		3/8" LOADING ARM BRANCH BASE		036083
1/2" Hydraulic Hoses					
Purple	188"	260"	320"	1/2" TURNER MOTOR	036564 <sup>3</sup>
Black	188"	260"	120"	1/2" TURNER MOTOR (BX TURNER ON BX10)	036564 <sup>3</sup>
Plain	24"		1/2" MOTOR TO VALVE		036079
Purple/Black	236"		1/2" TURNER MOTOR TO BX TURNER MOTOR		
3/4" Low Pressure Hydraulic Hoses					
Plain	35"	44"	35"	3/4" LOW PRESSURE VALVE TO FILTER	
Plain	35"	44"	35"	3/4" LOW PRESSURE TANK TO PUMP	
3/8" Hydraulic Hoses (Power Taper Set Roller Option)					
Plain	300"		3/8" POWER TAPER SET ROLLER		042828
Plain	300"		3/8" POWER TAPER SET ROLLER		042828

<sup>1</sup> Rev. A7.00: Toe Board hose lengths shortened to accommodate routing outside of frame. Toe Board #1 and hoses removed. Log Loader hoses removed and structured with option.

<sup>2</sup> Loading Arm became optional after Rev. A3.00. Hoses supplied with option.

<sup>3</sup> Turner motor hoses 036564 lengthened 6" to accommodate 7-section valve (Rev. A9.00).



## 8.6 Hydraulic Hoses

LT300

Rev. A5.00 - A6.01

ID	Color Code	LENGTH "A" <sup>1</sup>	Application	Part No.
H1	Plain	24"	1/2" Motor to Valve	036079
H2	Plain	44"	3/8" Low Pressure Valve to Filter	
H3	Plain	44"	3/8" Low Pressure Tank to Pump	
H4	Orange	210"	3/8" Clamp In/Out Base	036069
H5	White	220"	3/8" Clamp In/Out Top	036563
H6	Green	269"	1/4" Clamp Up/Down Top	036066
H7	Yellow	256"	1/4" Clamp Up/Down Base	036560
H8	Pink	224"	3/8" Turner Up/Down Base	036561
H9	Plain	224"	3/8" Turner Up/Down Top	036561
H10	Plain	29"	3/8" Front Side Support Top	036074
H11	Plain	39"	3/8" Rear Side Support Top	036075
H12	Plain	39"	3/8" Front Side Support Base	036075
H13	Plain	43"	3/8" Rear Side Support Base	036077
H14	Plain	23"	3/8" Side Support T-Branch	036073
H15	Grey	172"	1/4" Toe Roller #2 Base	036555
H16	Yellow	172"	1/4" Toe Roller #2 Top	036555
H17	Black	249"	1/4" Toe Roller #3 Base	036556
H18	Purple	249"	1/4" Toe Roller #3 Top	036556
H19	Red	293"	1/4" Toe Roller #4 Top	036557
H20	Blue	289"	1/4" Toe Roller #4 Base	036558
H21	White	129"	1/4" Toe Roller #1 Base	036554
H22	Orange	136"	1/4" Toe Roller #1 Top	036553
H23	Blue	230"	3/8" Loading Arm Top	036565
H24	Red	230"	3/8" Loading Arm Base	036565
H25	Green	56"	3/8" Loading Arm Branch Top	036081
H26	Green	88"	3/8" Loading Arm Branch Top	036080
H27	Yellow	54"	3/8" Loading Arm Branch Base	036083
H28	Yellow	86"	3/8" Loading Arm Branch Base	036082
H29	Black/Purple	188"	1/2" Turner Motor	036564 <sup>2</sup>
H30	Plain	23"	3/8" Side Support T-Branch	036073

TABLE 8-2

<sup>1</sup> Hose lengths increased 20" to accommodate 26' LT300 bed (Rev. A5.00).

<sup>2</sup> Turner motor hoses 036564 lengthened 6" to accommodate 7-section valve (Rev. A9.00).

## 8.7 Hydraulic Hoses

LT300

Rev. A1.00 - A4.00

ID	Color Code	LENGTH "A"	Application	Part No. <sup>1</sup>
H1	Plain	24"	1/2" Motor to Valve	036079
H2		44"	3/8" Low Pressure Valve to Filter	
H3		44"	3/8" Low Pressure Tank to Pump	
H4	Orange	191"	3/8" Clamp In/Out Base	036071
H5	White	200"	3/8" Clamp In/Out Top	036072
H6	Green	247"	1/4" Clamp Up/Down Top	036067
H7	Yellow	235"	1/4" Clamp Up/Down Base	036068
H8	Pink	204"	3/8" Turner Up/Down Base	036070
H9	Plain	204"	3/8" Turner Up/Down Top	036070
H10	Plain	29"	3/8" Front Side Support Top	036074
H11	Plain	39"	3/8" Rear Side Support Top	036075
H12	Plain	37"	3/8" Front Side Support Base	036076
H13	Plain	43"	3/8" Rear Side Support Base	036077
H14	Plain	23"	3/8" Side Support T-Branch	036073
H15	Grey	152"	1/4" Toe Roller #2 Base	036063
H16	Yellow	152"	1/4" Toe Roller #2 Top	036063
H17	Black	229"	1/4" Toe Roller #3 Base	036064
H18	Purple	229"	1/4" Toe Roller #3 Top	036064
H19	Red	273"	1/4" Toe Roller #4 Top	036065
H20	Blue	269"	1/4" Toe Roller #4 Base	036066
H21	White	109"	1/4" Toe Roller #1 Base	036062
H22	Orange	116"	1/4" Toe Roller #1 Top	036061
H23	Blue	210"	3/8" Loading Arm Top	036069
H24	Red	210"	3/8" Loading Arm Base	036069
H25	Green	56"	3/8" Loading Arm Branch Top	036081
H26	Green	88"	3/8" Loading Arm Branch Top	036080
H27	Yellow	54"	3/8" Loading Arm Branch Base	036083
H28	Yellow	86"	3/8" Loading Arm Branch Base	036082
H29	Black/Purple	162"	1/2" Turner Motor	036078
H30	Plain	23"	3/8" Side Support T-Branch	036073

TABLE 8-3

<sup>1</sup> Double-braided hoses replace all hydraulic hoses previously supplied prior to Rev. A3.00.

## 8.8 Hydraulic Components

ID	Mfg. Part No.	Manufacturer	Wood-Mizer Part #	Description
C1	017275	J-D Hydraulic	017275	Hyd. Cylinder, 3" Bore X 7" Stroke
C2	PMC-19410	Prince Mfg.	015050	Hyd. Cylinder, 1 1/2" Bore X 10" Stroke
C3	034267	J-D Hydraulic	034267	Hyd. Cylinder, 2" Bore x 10" Stroke
C4	035625	J-D Hydraulic	035625	Hyd. Cylinder, 2" Bore X 6" Stroke
C5	014482	J-D Hydraulic	014482	Hyd. Cylinder, 1 1/2" Bore x 6" Stroke
C6	042754	J-D Hydraulic	042754 <sup>1</sup>	Hyd. Cylinder, 3" Bore X 8" Stroke
F1	S28	Hyd. Filter Supply	P20301	Filter, Hydraulic Fluid Cartridge
F2	S15-100	FlowEzy	P20210	Filter, Hydraulic Tank Suction
G1	CF-1P-210A	Pressure Devices Inc.	P10052	Gauge, 5000 PSI Hydraulic
M1	LM24960	Lincoln	042776	Motor, 7.5HP 213TC 50/60Hz 415/480V
M2	TG0475US080AABP	Parker	007331 <sup>2</sup>	Motor, Hydraulic Log Turner Chain
P1	4F666	Grainger	042782	Hydraulic Pump, 6GPM 50Hz
V1	HF37166-06	Scott Industrial Sys.	025689 <sup>3</sup>	Valve, 7-Section Hydraulic
V2	49005-1000	Vonberg	042724	Sequence Valve, 1000 psi
V3	28001-503-6.5	Vonberg	038734 <sup>4</sup>	Valve, Hydraulic 6.5GPM Velocity Fuse
	28001-503-6.0	Vonberg	038735 <sup>4</sup>	Valve, Hydraulic 6GPM Velocity Fuse
V4	FD10-41-6T-N-33	Hydraforce	007588 <sup>5</sup>	Valve, Flow Divider
V5	SV10-34-6T-N-24DG	Hydraforce	007589 <sup>5</sup>	Valve, 24VDC Flow Diverter

**TABLE 8-4**

<sup>1</sup> Hydraulic log loader became optional after Rev. A3.00.

<sup>2</sup> Hydraulic Motor 007331 replaces 018741 originally supplied prior to 6/09. 018741 was changed by the vendor and no longer fits the hole in the log turner arm. 018741 MB29-02-08-AABP motor replaced 018181 MB15-02-08 motor to increase turner weight capacity (Rev. A3.00).

<sup>3</sup> 8-Port valve 042329 obsolete. Valve assembly replaced with 7-port valve 036731 (Rev. A9.00). Use kit 036758 to replace valve on LT300. Add valve kit 036824 if LT300 equipped with optional log loader. Add valve kit 036825 if LT300 equipped with optional deck. Valve 025689 replaces Valve 036731 (Progressive Power #BKAA0151 X0405) originally supplied prior to 8/10. Use component parts to service or replace with Valve 025689.

<sup>4</sup> 038734 6.5GPM Valve for LT300 Rev. B1.00 and later. Use 042755 6GPM Valve for previous revisions.

<sup>5</sup> BX10 Only.

# INDEX

---

## A

### alignment

- align side supports 7-6
- bed frame length 7-1
- bed frame width 7-2
- level bed rails 7-5
- level saw head 7-3
- standard block/roller guides
  - blade guide 7-22
  - blade guide arm 7-20
  - blade guide overview 7-7
  - blade guide preparation 7-17
  - blade wheel vertical tilt 7-18

---

## B

### belt

- tension 5-20

---

## C

### chain

- feed tension 5-17
- maintenance 5-9
- turner tension 5-24

---

## E

### electrical installation

- bed sensor cable 3-68
- blade motor cable 3-35, 3-49, 3-63
- head box cable 3-36, 3-50, 3-64
- lubemizer cable 3-39, 3-53, 3-67
- power feed cable 3-33, 3-47, 3-61
- transducer cable 3-38, 3-52, 3-66
- up/down brake cable 3-34, 3-48, 3-62
- up/down cable 3-33, 3-47, 3-61

---

## H

### hydraulic

- component ID 8-9
- hose ID 8-5, 8-7, 8-8
- schematic 8-1, 8-2, 8-3, 8-4

---

## M

### maintenance

- blade guide 5-1
- blade wheel bearings/scrapers 5-14
- drive belt 5-20
- hydraulic system 5-13
- miscellaneous 5-9
- power feed 5-17
- proximity sensors 5-10
- sawdust removal 5-5
- track rails/scrapers 5-6
- turner chain 5-24
- up/down 5-14
- up/down system 5-15

---

## O

### operation

- control overview 4-1
- cruise control 4-12
- distribution box overview 4-5
- installing a blade 4-19
- joystick overview 4-7
- loading a log 4-22
- programming the control 4-13
- sawing the log 4-38
- setworks overview 4-28
  - board function 4-37
  - pattern mode 4-35
  - temporary reference mode 4-29
- starting the machine 4-18

---

## S

### safety

- instructions 1-2
- lockout procedure 1-6
- symbol definitions 1-1

### service info

- customer/sawmill ID 2-2
- getting service 2-1
- ordering parts 2-1

### setup

- adjust transducer sensor 3-89
- air installation 3-75
- blade lube installation 3-21
- electrical installation 3-27, 3-42, 3-56
- extension installation 3-6
- final sawmill 3-77
- hydraulic installation 3-69
- initial control programming 3-89
- level bed rails 3-84
- level blade guide arm 3-85
- level saw head 3-80
- operator station installation 3-3
- sawmill installation 3-5
- side supports 3-88
- site preparation 3-1

---

## T

### troubleshooting

- blade guides 6-5
- error codes 6-1