

**Wood-Mizer® WM4500
Safety, Setup & Operation Manual**

WM4500

rev. A4.00-A4.04

Safety is our #1 concern! Read and understand all safety information and instructions before operating, setting up or maintaining this machine.

Form #2351

California
Proposition 65 Warning



WARNING: Breathing gas/diesel engine exhaust exposes you to chemicals known to the State of California to cause cancer and birth defects or other reproductive harm.

- Always start and operate the engine in a well-ventilated area.
- If in an enclosed area, vent the exhaust to the outside.
- Do not modify or tamper with the exhaust system.
- Do not idle the engine except as necessary.

For more information go to **www.P65warnings.ca.gov**.



WARNING: Drilling, sawing, sanding or machining wood products can expose you to wood dust, a substance known to the State of California to cause cancer. Avoid inhaling wood dust or use a dust mask or other safeguards for personal protection.

For more information go to **www.P65Warnings.ca.gov/wood**.

Active Patents assigned to Wood-Mizer, LLC

Wood-Mizer, LLC has received patents that protect our inventions which are a result of a dedication to research, innovation, development, and design. Learn more at: woodmizer.com/patents

©2022 Wood-Mizer LLC

Printed in the United States of America, all rights reserved. No part of this manual may be reproduced in any form by any photographic, electronic, mechanical or other means or used in any information storage and retrieval system without written permission from

Wood-Mizer, LLC
8180 West 10th Street
Indianapolis, Indiana 46214

Table of Contents

Section-Page

SECTION 1	INTRODUCTION	1-1
1.1	About This Manual.....	1-1
1.2	Getting Service.....	1-1
1.3	Specifications.....	1-1
1.4	Customer and Sawmill Identification.....	1-1
1.5	Specifications.....	1-3
1.6	Major Components.....	1-5
SECTION 2	SAFETY	2-1
2.1	Safety Symbols.....	2-1
2.2	Safety Instructions.....	2-1
	<i>Observe ALL Safety Instructions.....</i>	<i>2-1</i>
2.3	Electrical Lockout Procedures.....	2-6
SECTION 3	SETUP	3-1
3.1	Site Preparation.....	3-1
3.2	Operator Station Installation.....	3-2
3.3	Sawmill Installation.....	3-4
3.4	Hydraulic Log Clamp Installation.....	3-6
	<i>Hydraulic Log Clamp Installation (Sawmill Bed).....</i>	<i>3-6</i>
3.5	Pantograph Cable Boom.....	3-7
3.6	Electrical Installation.....	3-15
	<i>Electrical Requirements.....</i>	<i>3-15</i>
	<i>Installation.....</i>	<i>3-16</i>
	<i>Blade Motor Cable (W1).....</i>	<i>3-20</i>
	<i>Hydraulic Pump Motor (W2).....</i>	<i>3-21</i>
	<i>Feed Motor Cable (W3).....</i>	<i>3-22</i>
	<i>Up/Down Servo Motor Cable (W4).....</i>	<i>3-23</i>
	<i>Up/Down Servo Encoder Cable (W5).....</i>	<i>3-24</i>
	<i>Low Voltage Box Cables (W20-22, W41, W103 and W131).....</i>	<i>3-24</i>
3.7	Bio-Lube Installation.....	3-26
3.8	Hydraulic Installation.....	3-28
	<i>Hydraulic Installation (Optional BX12 Bed Extension Only).....</i>	<i>3-33</i>
3.9	Air Installation.....	3-35
3.10	Sawmill Installation Setup.....	3-36
	<i>Level Sub-Frame.....</i>	<i>3-36</i>
	<i>Level Saw Head.....</i>	<i>3-38</i>
	<i>Level Bed Rails.....</i>	<i>3-42</i>
	<i>Level Blade Guide Arm.....</i>	<i>3-43</i>
	<i>Adjust the blade guides for sawing.....</i>	<i>3-45</i>
3.11	Setworks setup.....	3-46
3.12	Initial Sawmill Setup.....	3-47
	<i>Installation Configuration.....</i>	<i>3-47</i>
	<i>Installation configuration.....</i>	<i>3-48</i>
	<i>Feed Setup.....</i>	<i>3-51</i>
	<i>Head Setup.....</i>	<i>3-53</i>
	<i>Upper and Lower Saw Head Stop Adjustment.....</i>	<i>3-54</i>
	<i>Setworks Setup.....</i>	<i>3-56</i>

Table of Contents

Section-Page

SECTION 4	NETWORKS	4-1
4.1	Overview	4-1
	<i>Setworks Operating Modes</i>	4-1
4.2	Screen elements	4-4
4.3	List of screens	4-5
	<i>Main Screen</i>	4-6
	<i>Alarm History log</i>	4-7
	<i>Setworks - Setup</i>	4-8
	<i>Setworks - Manual</i>	4-9
	<i>Setworks - Reference Mode</i>	4-11
	<i>Setworks - Pattern Mode</i>	4-13
	<i>Stack Mode</i>	4-14
	<i>Dashboard</i>	4-15
	<i>Setup-(Options1)</i>	4-18
	<i>Setup (Options2)</i>	4-20
	<i>Installation Configuration</i>	4-22
	<i>Feed Setup</i>	4-24
	<i>Head Setup</i>	4-26
	<i>Hydraulic Function Speeds</i>	4-27
	<i>Joystick Configuration</i>	4-28
	<i>Right Joystick Button Config. Head Mode</i>	4-29
	<i>Left Joystick Button Config. Head Mode</i>	4-31
	<i>Right Joystick Button Config. Bed Mode</i>	4-31
	<i>Left Joystick Button Config. Bed Mode</i>	4-32
4.4	Initial Sawmill Setup	4-33
	<i>Installation Configuration</i>	4-33
	<i>Installation configuration</i>	4-34
	<i>Feed Calibration</i>	4-35
	<i>Head Calibration</i>	4-38
	<i>Upper and Lower Saw Head Stop Adjustment</i>	4-39
	<i>Setworks Board/Cant Size Setup</i>	4-41
4.5	Diagnostics	4-46
	<i>PLC 1 - 7</i>	4-47
	<i>Feed Drive 1 & 2</i>	4-48
	<i>Head Drive 1 & 2</i>	4-48
	<i>Blade Soft Start 1 & 2</i>	4-49
SECTION 5	ALIGNMENT	5-1
5.1	Bed Frame	5-1
	<i>Level Bed Frame Along the Length</i>	5-1
	<i>Level Bed Frame Along the Width</i>	5-2
	<i>Level Saw Head</i>	5-3
	<i>Level Bed Rails</i>	5-6
	<i>Align Side Supports</i>	5-7

Table of Contents

Section-Page

5.2	Blade Guides	5-8
	<i>Blade Guide Adjustment Overview</i>	5-9
	<i>Preparing For Blade Guide Alignment</i>	5-11
	<i>Blade Wheel Vertical Alignment</i>	5-13
	<i>Blade Guide Arm Alignment</i>	5-15
	<i>Blade Guide Alignment</i>	5-17
	<i>Blade Guide Assemblies Downward Deflection</i>	5-18
	<i>Blade Guide Vertical Alignment</i>	5-19
	<i>Blade Guide Horizontal Alignment</i>	5-21

SECTION 6 OPERATION

6-1

6.1	Control Overview	6-1
6.2	Distribution Box Overview	6-3
6.3	Joystick Control Overview	6-4
	<i>Head Mode, Left Joystick</i>	6-5
	<i>Head Mode, Right Joystick</i>	6-7
	<i>Bed Mode: Right Joystick</i>	6-10
6.4	Programming the Control	6-12
	<i>System Setup</i>	6-12
	<i>Options 2 screen</i>	6-15
	<i>Joystick Configuration</i>	6-17
	<i>Feed Setup</i>	6-19
	<i>Position Calibration Procedure</i>	6-21
	<i>Head Setup</i>	6-22
	<i>Position Calibration Procedure</i>	6-23
	<i>Hydraulic Setup</i>	6-23
	<i>Setworks Setup</i>	6-24
	<i>Bed Extension Setup (Optional)</i>	6-24
6.5	Starting the Controls	6-27
6.6	Installing A Blade.....	6-28
6.7	Loading, Turning And Clamping Logs	6-33
6.8	General Sawing Sequence	6-36
	<i>Prepare the sawmill</i>	6-36
	<i>Make the opening cut on the first side</i>	6-36
	<i>Turn the log to side 2</i>	6-37
	<i>Make the opening cut on the second side</i>	6-38
	<i>Make the opening cut on the third side</i>	6-38
	<i>Make the opening cut on the fourth side</i>	6-39
	<i>Return to the staging position, if set</i>	6-39
6.9	Automated Sawing Sequence	6-40
	<i>Prepare the sawmill for loading a log</i>	6-40
	<i>Make the opening cut on the first side</i>	6-41
	<i>Turn the log to side 2</i>	6-42
	<i>Make the opening cut on the second side</i>	6-43
	<i>Make the opening cut on the third side</i>	6-43
	<i>Make the opening cut on the fourth side</i>	6-44
	<i>Return to the staging position, if set.</i>	6-44

SECTION 7 MAINTENANCE

7-1

7.1	Blade Guides	7-1
-----	--------------------	-----

Table of Contents

Section-Page

7.2	Sawdust Removal	7-3
7.3	Track Rails & Scrapers	7-4
7.4	Miscellaneous	7-6
7.5	Proximity Sensors.....	7-8
	<i>Broken Blade Sensor</i>	7-8
	<i>Up/Down Ball Screw Sensor</i>	7-8
7.6	Hydraulic System Maintenance.....	7-10
7.7	Blade Wheel Bearings & Scrapers	7-11
7.8	Up/Down System.....	7-12
7.9	Power Feed	7-15
7.10	Drive Belt Tension & Alignment	7-18
7.11	Turner Chain Tension.....	7-21
7.12	Maintenance Chart.....	7-23

SECTION 8 HYDRAULIC INFORMATION

8-1

8.1	Hydraulic Schematics	8-1
8.2	Hydraulic Schematics BX12	8-14
8.3	Hydraulic Schematics Double Bed.....	8-36
8.4	Hydraulic Components	8-59
8.5	Hydraulic Components BX12	8-61
8.6	Hydraulic Components Double Bed.....	8-64
8.7	Hydraulic Hoses	8-68
8.8	Hydraulic Hoses BX12	8-70
8.9	Hydraulic Hoses Double Bed	8-73

SECTION 1 INTRODUCTION

1.1 About This Manual

This manual replaces any previous information received on your Wood-Mizer® equipment.

The information and instructions in this manual do not amend or extend the limited warranties for the equipment given at the time of purchase.

1.2 Getting Service

For contact information, sales, service, parts, and additional manuals, sign into your account on <https://woodmizer.com>, or call inside the USA: 1-800-553-0182 or from outside the USA: 317-271-1542

1.3 Specifications

Equipment specification are included in the Online Manuals, which are found at <https://apps.woodmizer.com/Manuals/Manuals.aspx?parent=0>.

1.4 Customer and Sawmill Identification

Each Wood-Mizer sawmill is identified with a serial number, revision, and electrical information (see the figure below).

1 Introduction

Customer and Sawmill Identification

The serial number contains the year and month of manufacture and a sequence number.

MFG BY: WOOD-MIZER LLC, 8180 W. 10th St. Indianapolis, IN 46214-2400					
317/271-1542 or 800/553-0182					
SERIAL #	WM4500 0103002A1.00	FLA OF LARGEST LOAD	<input type="text"/>		
FLA	<input type="text"/>	IR	<input type="text"/>	SCCR	<input type="text"/>
<small>(Base unit only)</small>					
VOLTS		<input type="text"/>		HZ	<input type="text"/>
PH		<input type="text"/>			
ELECTRICAL DIAGRAM #	<input type="text"/>		PATENTS	<input type="text"/>	
					S20038
<small>300_0003C</small>					

IDENTIFICATION PLATE

The revision number helps identify the exact design of the equipment.

Model No.	Date Of Manufacture		Machine No.	Revision
	Year	Month		
WM4500	01	03	002	A1.00

SERIAL NUMBER DESCRIPTION

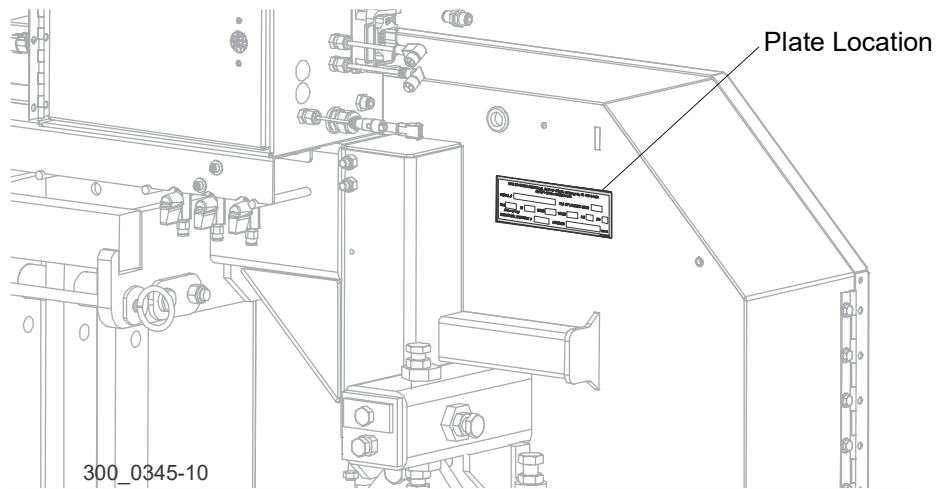

FIG. 1-1

1.5 Specifications

Model: WM4500 Rev. A1.00+

Dimensions

Length (Bed Frame):	27'-3 1/4"
Length (with Operator Station & 14" between):	33'-10"
Length (with Operator Station and Hydraulic	36'-10"
Width (Sawmill Only, Max Blade Guide Arm	9'-5 3/4"
Width (Sawmill w/Right-Hand Pantograph, Max	19'-6 1/2"
Boom & Blade Guide Arm Position):	
Width (Sawmill w/Left-Hand Pantograph, Max	15'-11 1/4"
Boom & Blade Guide Arm Position):	
Height (Ground To Mast):	9'-2 5/8"
Height (Pantograph):	10'-11 1/2"
Bed Height (Ground To Bed):	37 1/2"
Blade Length:	196"

Weights:

Basic Unit:	approx. 7000 lbs.
Saw Head Only:	2000 lbs.
Operator Station:	1665 lbs.
A/C Option:	96 lbs.
BX6 Bed Extension:	550 lbs.

Cutting Capacity:

Length:	22'-6"
Length (with Board Removal):	21'
Length w/BX6:	28'-6"
Length w/BX6 (with Board Removal):	27'
Length w/BX12:	34'-6"
Length w/BX12 (with Board Removal):	33'
Diameter:	40"
Weight:	approx. 4400 lbs
Max. Clamp Width (from stop block):	32"
Min. Clamp Width (from stop block):	1"
Max. Throat Width (guide to guide):	32"
Max. Cant Width (outer guide to stop block):	30"
Max. Cutting Depth @ 28" wide:	14"
Min. Cut Height:	1"
Max. Cut Height:	36"
Throat Height:	15 1/4"

Blade Motor:

Horsepower Rating:	30
Blade Braking:	approx. 2.6 sec

Rates:

Normal Power Usage:	66 Amps, 35.90 kVa or 42.60 kWh
Max. Forward (Cutting):	150 ft/min

1 Introduction

Specifications

Max. Forward (Not Cutting):	adjustable between 150-300 ft/min
Reverse:	300 ft./min.
Clamp (full travel):	0.9 sec
Log turner (turn 4200 lb. log 90°):	approx. 2.3 sec.

Options:

Debarker:	074060 (field installed) 074059 (factory installed)
Conveyor:	CB6-3.2
Log Deck	LD12-1, LD12HD, LD20-1, LD20HD with LT4000KIT
Pull down clamps	078887 for revision A2.00+ mills 078913 for revision A1.00- A.2.00 mills
12 ft and 6 ft Bed Extension	BSX12-4500, 4500BX6MR with LD4000BX12KIT
Secondary Side Supports	074672
A/C for Cab:	A/C1

Electrical Requirements:

Electrical Service:	460V 3-Phase 100A
Fused Disconnect:	200A
Time Delay Fuse:	150A
Cab Option (No A/C):	110V 1-Phase 15A Service
Cab Option (w A/C):	110V 1-Phase 30A Service
Suggested Wire Size (50' max.):	2AWG

Air Requirements:

Shop Air Supply:	110 psi@16.5 cfm
------------------	------------------

1.6 Major Components

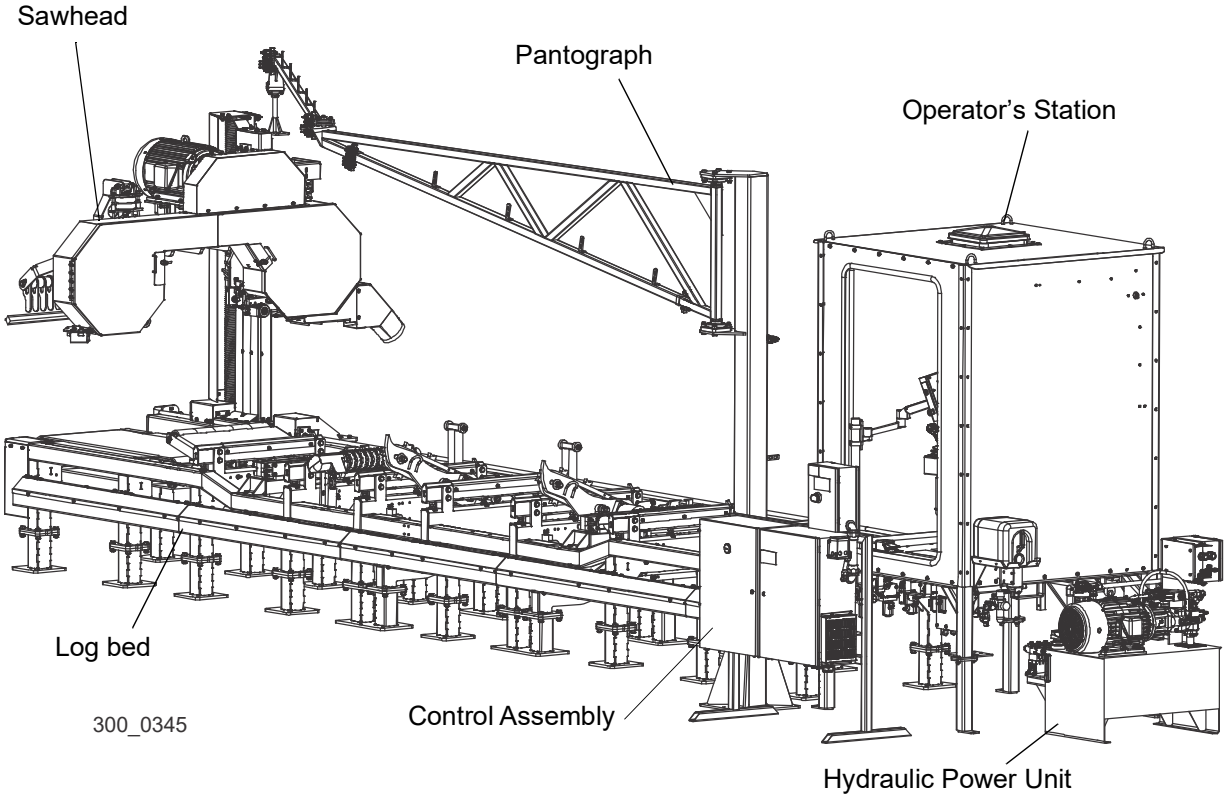



FIG. 1-2

SECTION 2 SAFETY

2.1 Safety Symbols

The following symbols and signal words call your attention to instructions concerning your personal safety. Be sure to observe and follow these instructions.

 **DANGER!** indicates an imminently hazardous situation which, if not avoided, will result in serious injury or death.

 **WARNING!** suggests a potentially hazardous situation which, if not avoided, could result in serious injury or death.

 **CAUTION!** refers to potentially hazardous situations which, if not avoided, may result in minor or moderate injury or damage to equipment.

NOTICE indicates vital information.

2.2 Safety Instructions

OWNER/OPERATOR'S RESPONSIBILITY

The procedures listed in this manual may not include all ANSI, OSHA, or locally required safety procedures. **It is the owner/operator's responsibility and not Wood-Mizer LLC to ensure all operators are properly trained and informed of all safety protocols.**

Owner/Operators are responsible for following all safety procedures when operating and performing maintenance to the equipment.

Observe ALL Safety Instructions

NOTICE Read the entire Operator's Manual before operating this equipment.

Note all safety warnings throughout this manual and those posted on the machine.

Be able to access this manual at all times while operating this equipment.

Read additional manufacturer's manuals and observe their applicable safety instructions.

Only persons who have read and understood the entire operator's manual should operate this equipment.

This equipment is not intended for use by or around children.

It is the owner/operator's responsibility to comply with all applicable federal, state, and local laws, rules, and regulations regarding the ownership, operation, and transporting your equipment.





Operators should become thoroughly familiar with and comply with these applicable laws for operating and transporting equipment

WEAR SAFETY CLOTHING

 **WARNING!** Secure all loose clothing and jewelry before operating the sawmill. Failure to follow this could result in serious injury or death.

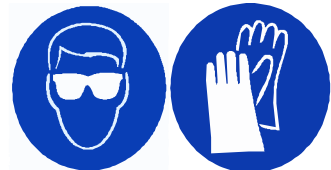
 **WARNING!** Always wear gloves and eye protection when handling bandsaw blades. Keep all personnel away from area when coiling, carrying, or changing a blade. Failure to follow this could result in serious injury or death.



 **WARNING!** Always wear eye, ear, and foot protection when operating or servicing the sawmill. Failure to follow this could result in serious injury or death.



 **WARNING!** Some woods require respiration protection when operating the sawmill. Failure to follow this could result in serious injury or death. **It is the sawyer's responsibility to know which woods require respiration protection.**

KEEP SAWMILL AND AREA AROUND SAWMILL CLEAN

 **DANGER!** Maintain a clean and clear path for all necessary movement around the mill and lumber stacking areas. Failure to follow this will result in serious injury or death.

HANDLE FUEL/LUBRICANTS SAFELY



WARNING! Never use flammable fuels or liquids such as diesel fuel with the water lube accessory. Failure to follow this could result in serious injury or death.

If these types of liquids are necessary to clean the blade, remove it and clean with a rag. Failure to follow this can damage the equipment and could result in serious injury or death.

DISPOSE OF SAWING BY-PRODUCTS PROPERLY

NOTICE Always properly dispose of all sawing by-products, including sawdust and other debris, coolant, oil, fuel, oil filters and fuel filters.

CAUTIONS FOR SAWMILL SETUP



WARNING! Securely fasten the feet of a stationary sawmill to the floor before operating the sawmill. Failure to follow this could result in serious injury or death.

CHECK SAWMILL/BLADES BEFORE OPERATION



DANGER! Ensure that all guards and covers are in place and secured before operating or towing the sawmill. Failure to follow this will result in serious injury or death.

Be sure the blade housing and pulley covers are in place and secure. Use the safety retainer pin and cable to fasten blade housing covers.



DANGER! Check and maintain your blades to prevent blade breakage during operation. Failure to follow this will result in serious injury or death.

Blade guide alignment is essential for optimal cutting performance, blade life and safety. Failure to check and maintain proper blade guide alignment will result in stress cracks forming in the blade. These cracks will lead to premature blade breakage. If the blade breaks during operation and the blade has multiple stress cracks, the blade could shatter into several pieces and escape from the protective guards of the sawmill. Small blade pieces projected into the area around the sawmill creates a safety hazard for the operator and any bystanders surrounding the mill.



DANGER! Never use blades with stress cracks. Failure to follow this will result in serious injury or death.

KEEP PERSONS AWAY



DANGER! Keep all persons out of the path of moving equipment and logs when operating sawmill or loading and turning logs. Failure to follow this will result in serious injury or death.



DANGER! Always be sure the blade is disengaged and all persons are out of the path of the blade before starting the engine or motor. Failure to follow this will result in serious injury or death.

KEEP HANDS AWAY



DANGER! Disengage the blade and shut off the sawmill engine before changing the blade. Failure to follow this will result in serious injury or death.



DANGER! Keep hands away from moving bandsaw blade. Failure to follow this will result in serious injury or death.



DANGER! Stay a safe distance from rotating members and ensure that loose clothing or long hair does not engage rotating members resulting in possible injury. Failure to follow this will result in serious injury or death.



WARNING! Do not spin the blade wheels by hand. Failure to follow this could result in serious injury or death.



WARNING! Disengage the blade whenever the sawmill is not cutting. Failure to follow this could result in serious injury or death.



WARNING! Never adjust the engine drive belts or belt support bracket with the motor running. Failure to follow this could result in serious injury or death.



WARNING! Keep hands, feet, and any other objects away from the sawdust chute when operating sawmill. Failure to follow this could result in serious injury or death.

2 Safety

Observe ALL Safety Instructions

USE PROPER PROCEDURE WHEN CONDUCTING ELECTRICAL SAFETY CHECKS AND MAINTENANCE

ARC FLASH AND SHOCK HAZARD! Hazardous voltage inside the electric sawmill disconnect box, starter box, and at the motor can cause shock, burns, or death.

- Disconnect and lock out power supply before servicing.
- Wear appropriate Personal Protection Equipment.

 **DANGER!** Keep all electrical component covers closed and securely fastened during mill operation. Failure to follow this will result in serious injury or death.

 **WARNING!** Consider all electrical circuits energized and dangerous. Failure to follow this could result in serious injury or death.



 **WARNING!** Never assume or take the word of another person that the power is off; check it out and lock it out. Failure to follow this could result in serious injury or death.

 **WARNING!** Do not wear rings, watches, or other jewelry while working around an open electrical circuit. Failure to follow this could result in serious injury or death.

 **WARNING!** Before performing service near moving parts such as blades, pulleys, motors, belts and chains, first turn the key switch to the OFF (0) position and remove the key. Failure to follow this could result in serious injury or death.

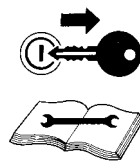

 **WARNING!** Remove the blade before performing any service to the engine or sawmill. Failure to follow this could result in serious injury or death.

KEEP SAFETY LABELS IN GOOD CONDITION

NOTICE Always be sure that all safety decals are clean and readable. Replace all damaged safety decals to prevent personal injury or damage to the equipment. Contact your local distributor, or call your Customer Service Representative to order more decals.

NOTICE If replacing a component that has a safety decal affixed to it, ensure that the new component also has the safety decal affixed.

USE CAUTION WHEN WORKING WITH HEAVY LOGS



WARNING! Ensure log is clamped securely before sawing. Failure to follow this could result in serious injury or death.

AUTOMATIC BOARD RETURN SAFETY



DANGER! Keep all persons out of the path of returning boards. Failure to follow this will result in serious injury or death.

2.3 Electrical Lockout Procedures

RULES FOR USING LOCKOUT PROCEDURE

The sawmill shall be locked out to protect against accidental or inadvertent operation when such operation could cause injury to personnel. Do not attempt to operate any switch or valve bearing a lock.

LOCKOUT PROCEDURES MUST BE USED DURING:

Changing or adjusting blades	Electrical maintenance
Unjamming operations	Retrieval of tools/parts from work area
Cleaning	Activities where guards or electrical panel guard is open or removed
Mechanical repair	

Table 1:

MAINTENANCE HAZARDS INCLUDE:

Blade contact	Missiles (thrown blades/wood chips)
Pinch points	Electrical
Kickbacks	

Table 2:

FAILURE TO LOCKOUT MAY RESULT IN:

Cut	Serious injury and death
Crush	Amputation
Blindness	Burn
Puncture	Shock
Electrocution	

Table 3:

TO CONTROL MAINTENANCE DANGERS:

- Lockout procedures must be followed (see OSHA regulation 1910.147).
- Never rely on machine stop control for maintenance safety (emergency stops, on/off buttons, interlocks).
- Do not reach into moving blades or feed systems. Allow all coasting parts to come to a complete stop.
- Electrical power supply and air supply must both be locked out.
- Where established lockout procedures cannot be used (electrical troubleshooting or mechanical dynamic troubleshooting), alternative effective protective techniques shall be employed which may require special skills and planning.
- Always follow safe operations practices in the workplace.

SAWMILL LOCKOUT PROCEDURE

Lockout procedures per OSHA regulation 1910.147, appendix A:

GENERAL

The following simple lockout procedure is provided to assist owner/operators in developing their procedures so they meet the requirements of OSHA regulation 1910.147. When the energy isolating devices are not lockable, tagout may be used, provided the owner/operator complies with the provisions of the standard which require additional training and more rigorous periodic inspections. When tagout is used and the energy isolating devices are lockable, the owner/operator must provide full operator protection (see OSHA regulation 1910.147, paragraph (c)(3)) and additional training and more rigorous periodic inspections are required. For more complex systems, more comprehensive procedures may need to be developed, documented, and utilized.

PURPOSE

This procedure establishes the minimum requirements for the lockout of energy isolating devices whenever maintenance or servicing is done on machines or equipment. It shall be used to ensure that the machine or equipment is stopped, isolated from all potentially hazardous energy sources and locked out before personnel perform any servicing or maintenance where the unexpected energization or start-up of the machine or equipment or release of stored energy could cause injury.

COMPLIANCE WITH THIS PROGRAM

All personnel are required to comply with the restrictions and limitations imposed upon them during the use of lockout. The authorized personnel are required to perform the lockout in accordance with this procedure. All operators, upon observing a machine or piece of equipment which is locked out to perform servicing or maintenance shall not attempt to start, energize, or use that machine or equipment.

SEQUENCE OF LOCKOUT

1. Notify all affected personnel that servicing or maintenance is required on a machine or equipment and that the machine or equipment must be shut down and locked out to perform the servicing or maintenance.
2. The authorized employee shall refer to the company procedure to identify the type and magnitude of the energy that the machine or equipment utilizes, shall understand the hazards of the energy, and shall know the methods to control the energy.
3. If the machine or equipment is operating, shut it down by the normal stopping procedure (depress the stop button, open switch, close valve, etc.).
4. De-activate the energy isolating device(s) so that the machine or equipment is isolated from the energy source(s).
5. Lock out the energy isolating device(s) with assigned individual lock(s).
6. Stored or residual energy (such as that in capacitors, springs, elevated machine members, rotating flywheels, hydraulic systems, and air, gas, steam, or water pressure, etc.) must be dissipated or restrained by methods such as grounding, repositioning, blocking, bleeding down, etc.
7. Ensure that the equipment is disconnected from the energy source(s) by first checking that no personnel are exposed, then verify the isolation of the equipment by operating the push button or other normal operating control(s) or by testing to make certain the equipment will not operate.



CAUTION! Return operating control(s) to neutral or "off" position after verifying the isolation of the equipment.

8. The machine or equipment is now locked out.

RESTORING EQUIPMENT TO SERVICE

When the servicing or maintenance is completed and the machine or equipment is ready to return to normal operating condition, the following steps shall be taken.

1. Check the machine or equipment and the immediate area around the machine to ensure that nonessential items have been removed and that the machine or equipment components are operationally intact.
2. Check the work area to ensure that all personnel have been safely positioned or removed from the area.
3. Verify that the controls are in neutral.
4. Remove the lockout devices and re-energize the machine or equipment.

NOTE: The removal of some forms of blocking may require re-energization of the machine before safe removal.

5. Notify affected personnel that the servicing or maintenance is completed and the machine or equipment is ready for use.

PROCEDURE INVOLVING MORE THAN ONE PERSON

In the preceding steps, if more than one individual is required to lock out the sawmill, **each shall place his own personal lock on the energy isolating devices.**

SECTION 3 SETUP

3.1 Site Preparation

NOTICE Have your site prepared **before** the installation date of your sawmill. Preparations needed are:

- Power supply pre-installed per mill requirements ([See Section 3.7](#))



DANGER! Ensure all electrical installation, service, and/or maintenance work is performed by a qualified electrician in accordance with applicable electrical codes. Failure to follow this will result in serious injury or death.

NOTE: Supply the electrician with the mill requirements **prior to the installation date** to give lead time for ordering any parts or wire quantities. This will prevent delays in installation.

- Layout prepared as determined at the time of purchase
- Enough room for operators, sawdust removal, log loading, and board removal
- A firm, level cement pad with a minimum thickness of 6" (155mm) and rebar spacing of 24" (600mm), rated to support 6350 lbs/sq ft (31,000 kg/m²) at each sawmill foot position
- Anchors 1/2" in diameter to secure the equipment to the slab
- Full protection from outdoor elements

3.2 Operator Station Installation

NOTICE Use a forklift rated for at least 8,000 lbs. Insert the forks into the pockets and secure with the pocket bolts.

1. Use a forklift to raise the operator station.
2. Install the 4 leg weldments to the operator station using the hardware. ([See FIG. 3-1.](#))
3. Lower the operator station in its final position.
4. Install the stair/platform assembly to the station deck using the hardware. ([See FIG. 3-1.](#))

NOTE: Anchoring the operator station is optional, although recommended. If the operator station is to be anchored, do so **after** the placement of the sawmill. This allows for repositioning of the operator station relative to the sawmill for your desired operator position.

5. Use 1/2" anchor bolts and nuts at each foot location to anchor the operator station.

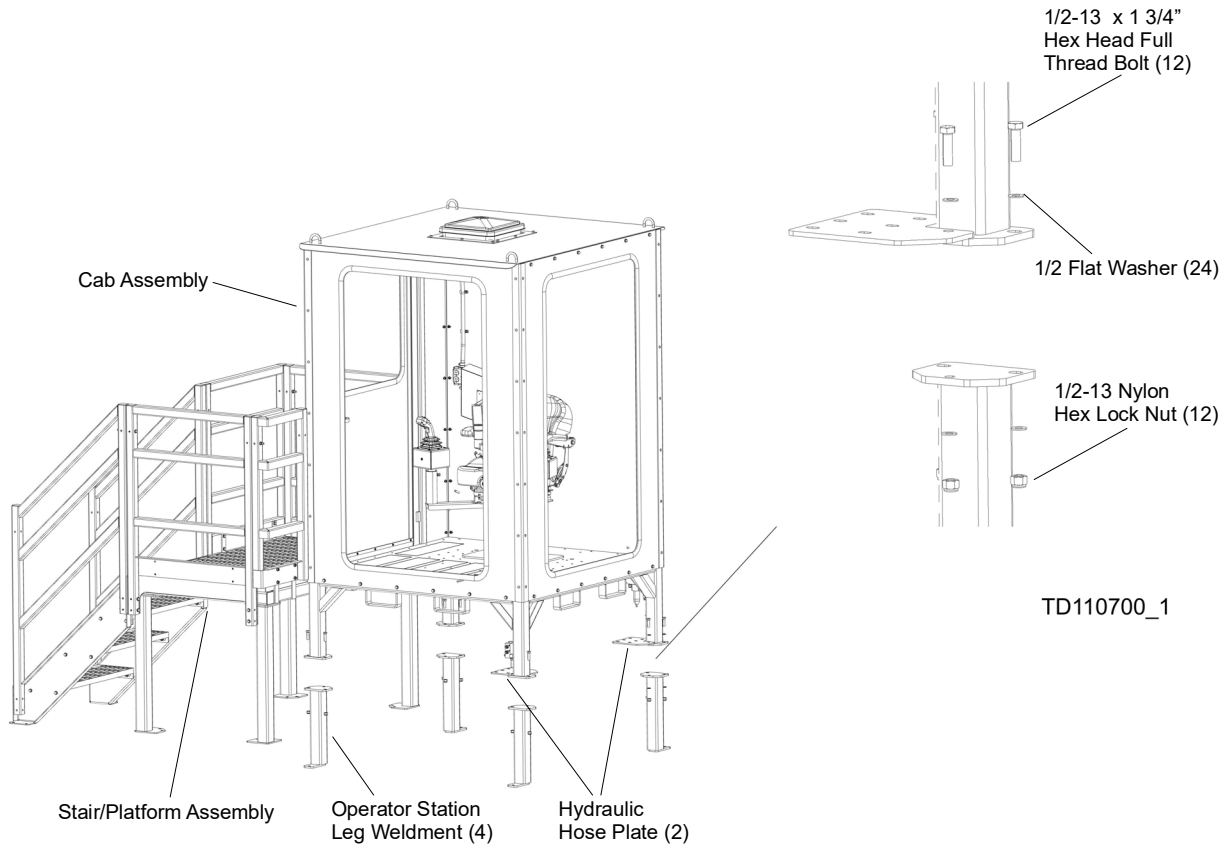

FIG. 3-1

3.3 Sawmill Installation

1. Position the sawmill bed approximately 12" from the operator station.

NOTE: *If sawmill is equipped with a bed extension option, place the sawmill an extra 6'-10" (BX6) from the operator station.*

2. Check the position of the operator station in relation to the sawmill.
 - a. Sit in the operator seat to view the log clamp and side supports.
 - b. Adjust the operator's station horizontally to obtain the best view of the sawmill.

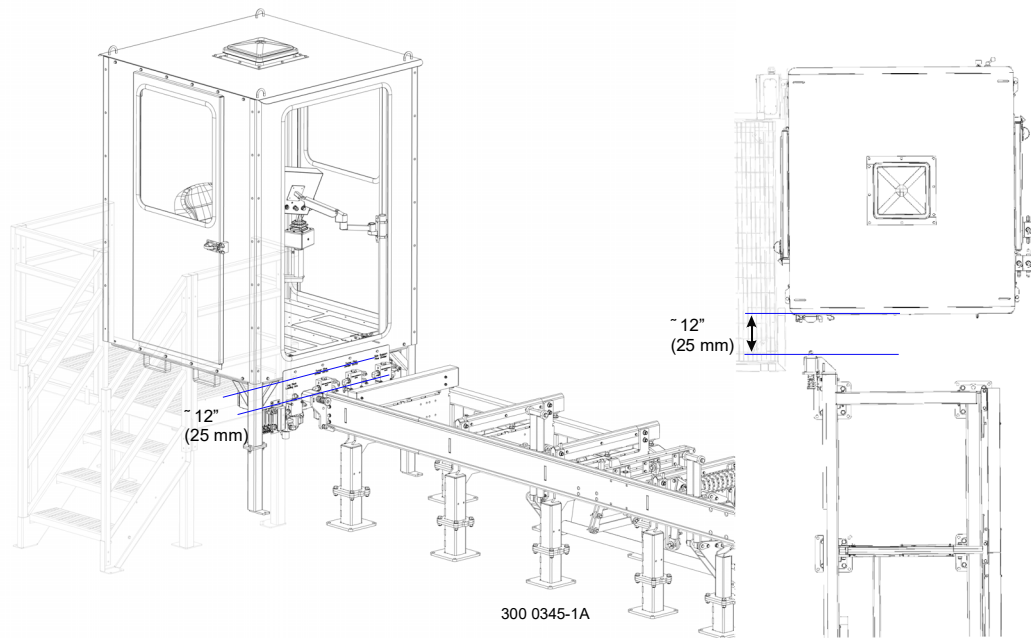

FIG. 3-2

3. Anchor the sawmill to the floor with (80) 1/2" anchor bolts and nuts.

NOTICE If you are not be able to drill all anchor bolt holes, use at least two holes at each foot location. Bolts in all locations is are recommended.

4. Remove the two fork tubes from the top of the sawmill bed.

5. Remove the saw head rest located under the outer side of the saw head and the two rail rod clamp assemblies from the track rails located on both sides of the saw head.

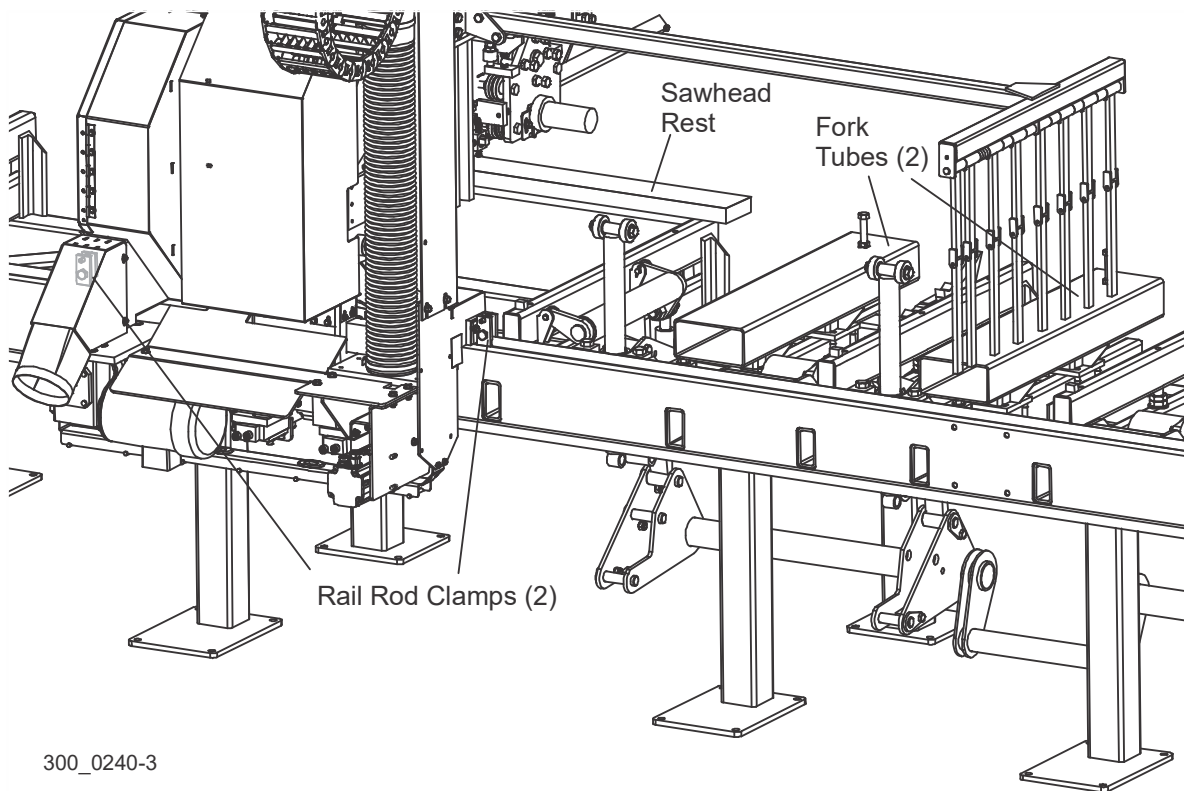

300_0240-3

FIG. 3-3

3.4 Hydraulic Log Clamp Installation

Hydraulic Log Clamp Installation (Sawmill Bed)

Anchor the hydraulic log clamp to the floor with 1/2" anchor bolts and nuts. See Fig. 3-4.

NOTICE: If installing the optional BX12 Bed Extension, see the BX12 manual for the alternate log clamp location.

See Section 3.8 for the hydraulic log clamp hose connections.

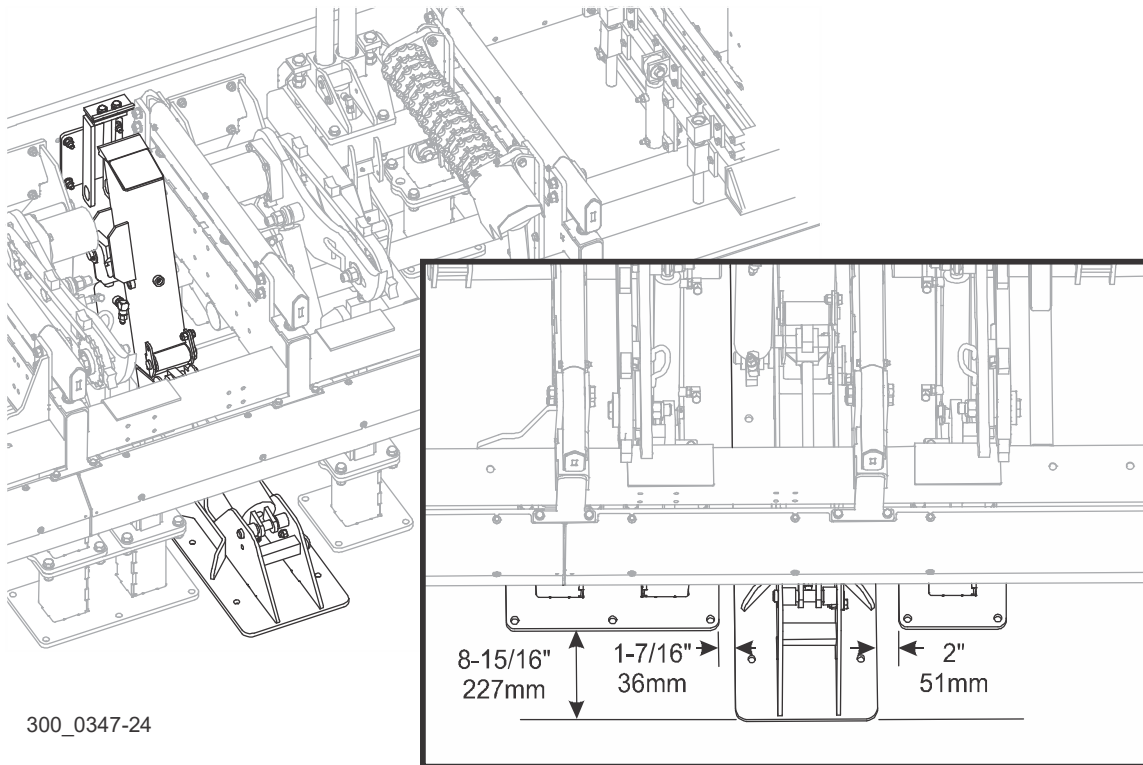

FIG. 3-4

3.5 Pantograph Cable Boom

NOTICE Make sure there is enough room around the sawmill for the pantograph movement after the pantograph assembly installation is complete.

1. Place the pantograph in position.

For sawmills without the bed extension option, select one of the right-hand or left-hand alternate positions for the pantograph main tube installation. (**NOTE:** The assembled pantograph is shown below.)

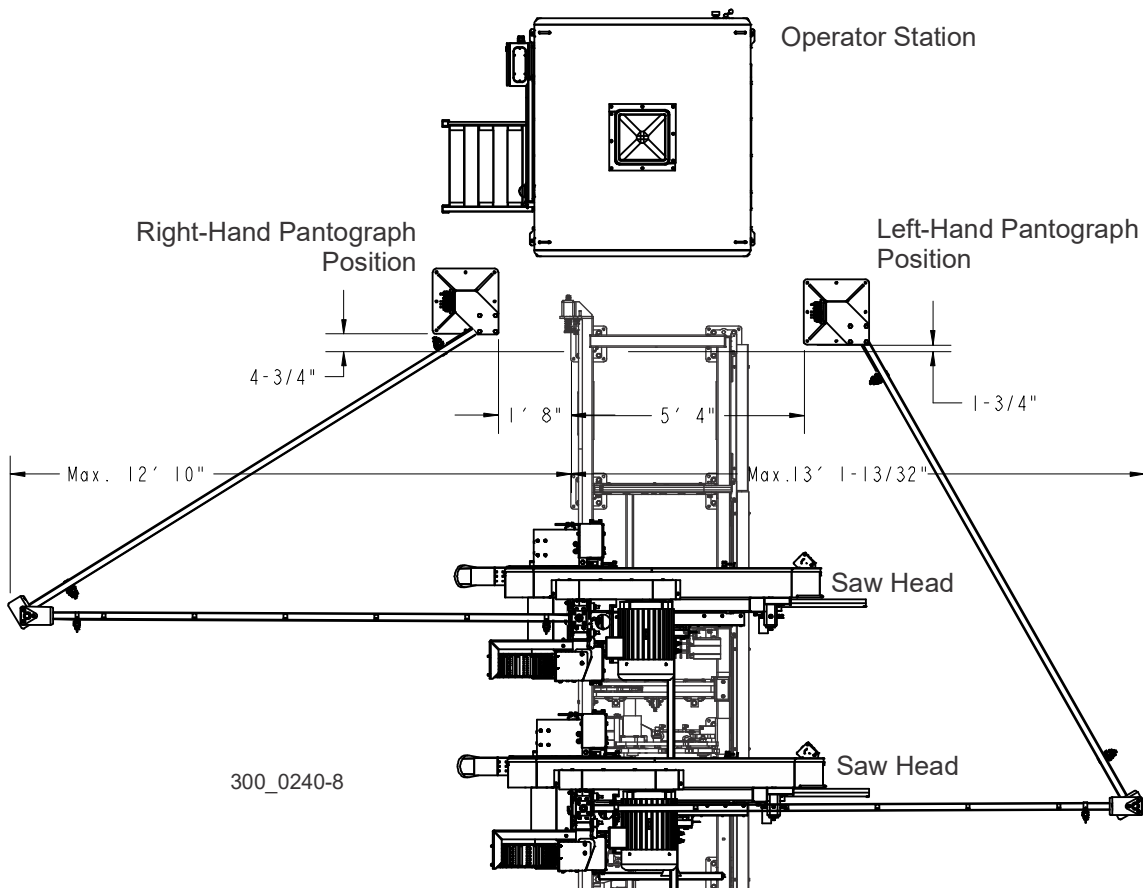

FIG. 3-5 WITHOUT BED EXTENSION

3 Setup
Pantograph Cable Boom

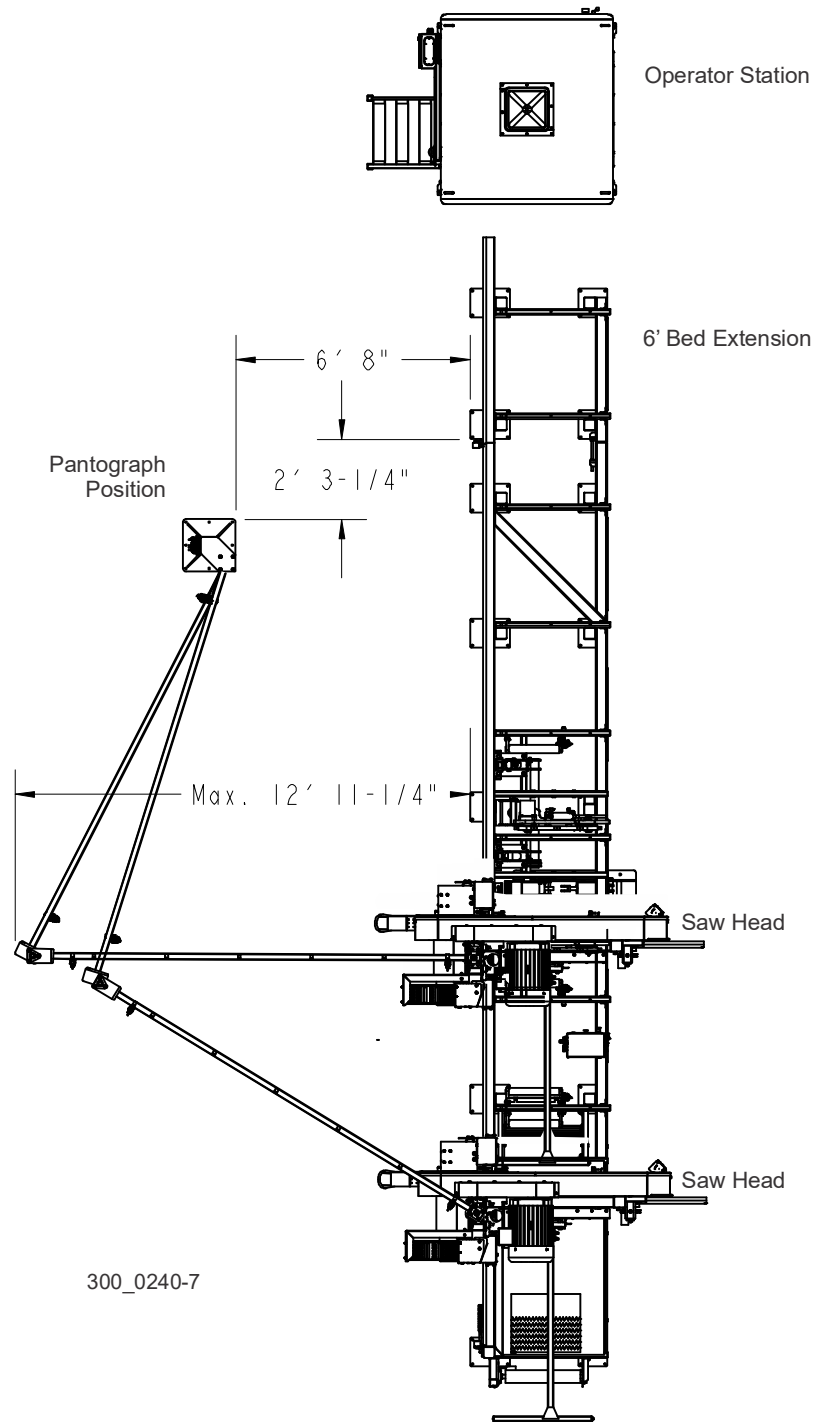

FIG. 3-6 WITH 12' BED EXTENSION

2. Secure the pantograph main tube weldment to the cement pad with eight 1/2" anchor bolts.
3. Install the two flange bearings to the upper and lower pivot ends on the frame weldment.
4. Install the pantograph frame weldment to the main tube with the 5/8-11 x 2 1/2" hex head bolts and 5/8-11 nylon lock nuts.

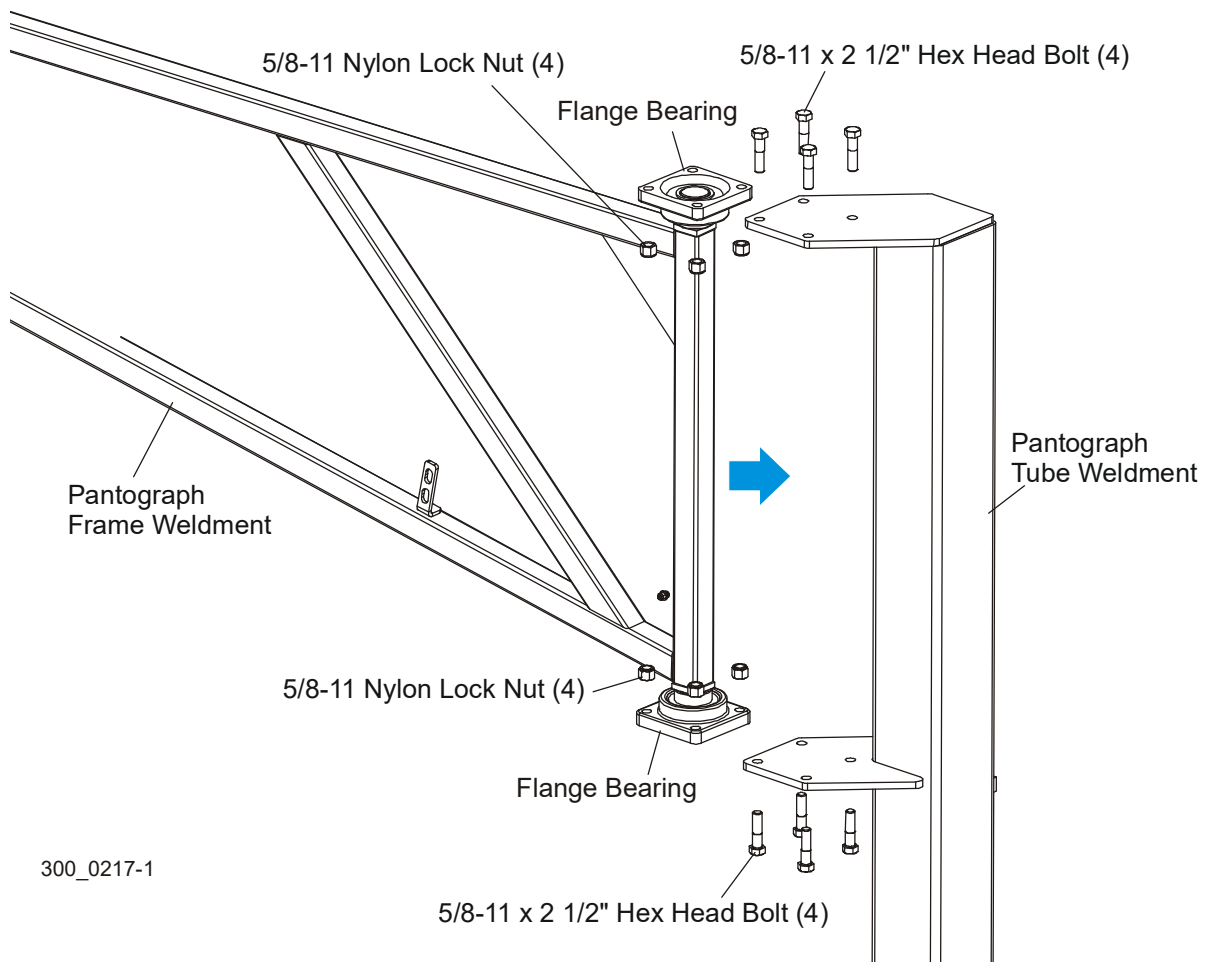

FIG. 3-7

3 Setup

Pantograph Cable Boom

5. Install the connector weldment to the end of the frame weldment as shown in Figure 3-8.

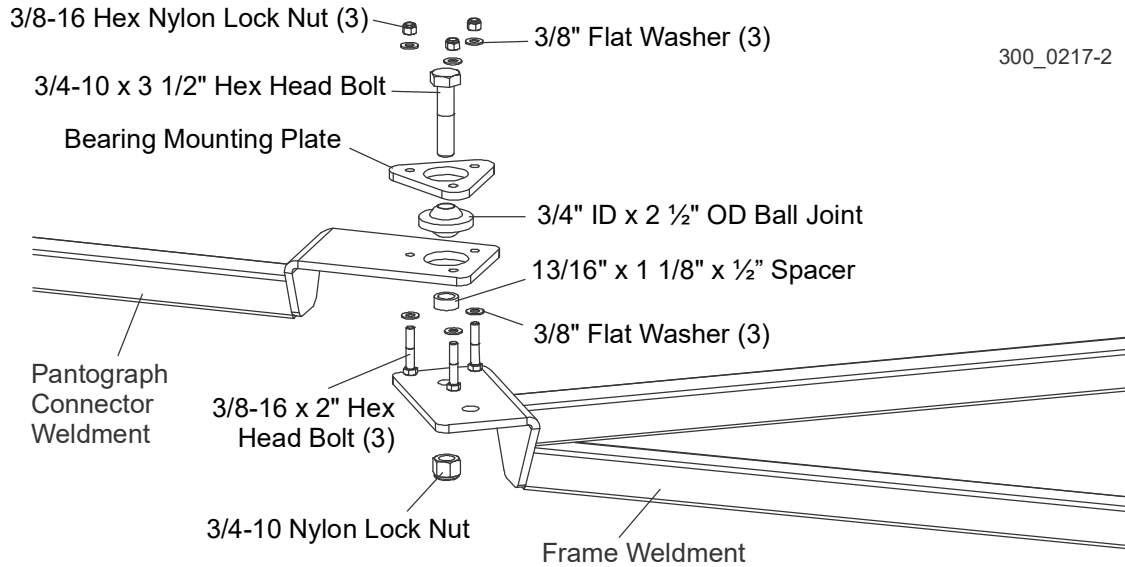
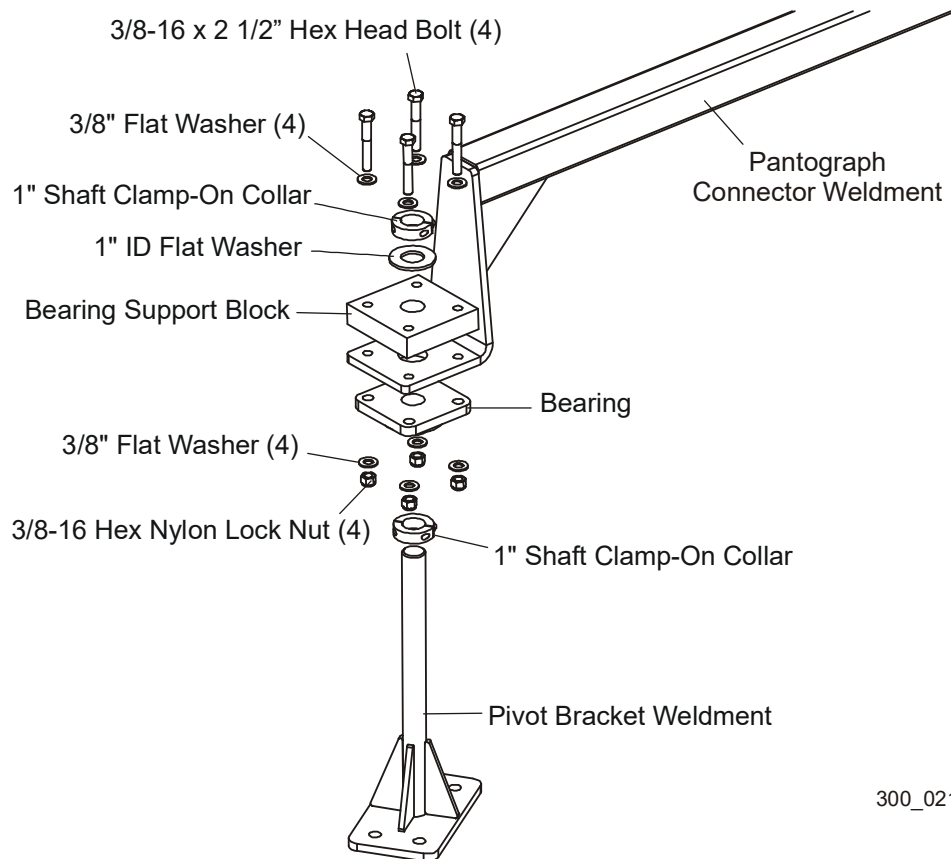

FIG. 3-8

6. Install the pantograph pivot bracket to the end of the connector weldment.

7. Move the pantograph connector weldment so that the pivot bracket is located directly above the sawmill mast.



300_0217-3

8. Remove the four bolts and lock washers securing the top bellow mount plate to the sawmill mast assembly.

3 Setup

Pantograph Cable Boom

- Use the 1/2-13 x 1 1/2" hex head bolts and the existing lock washers to secure the pivot bracket to the mast.

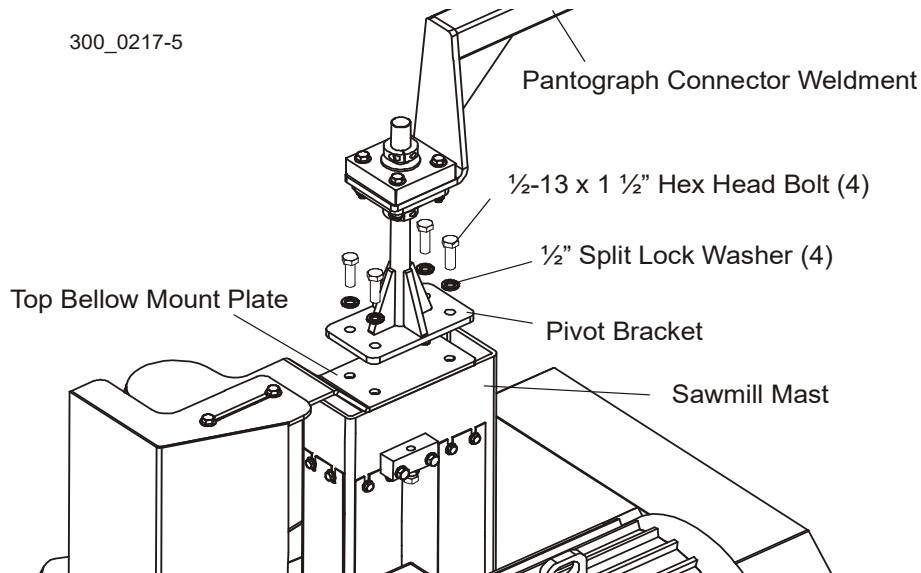

FIG. 3-9

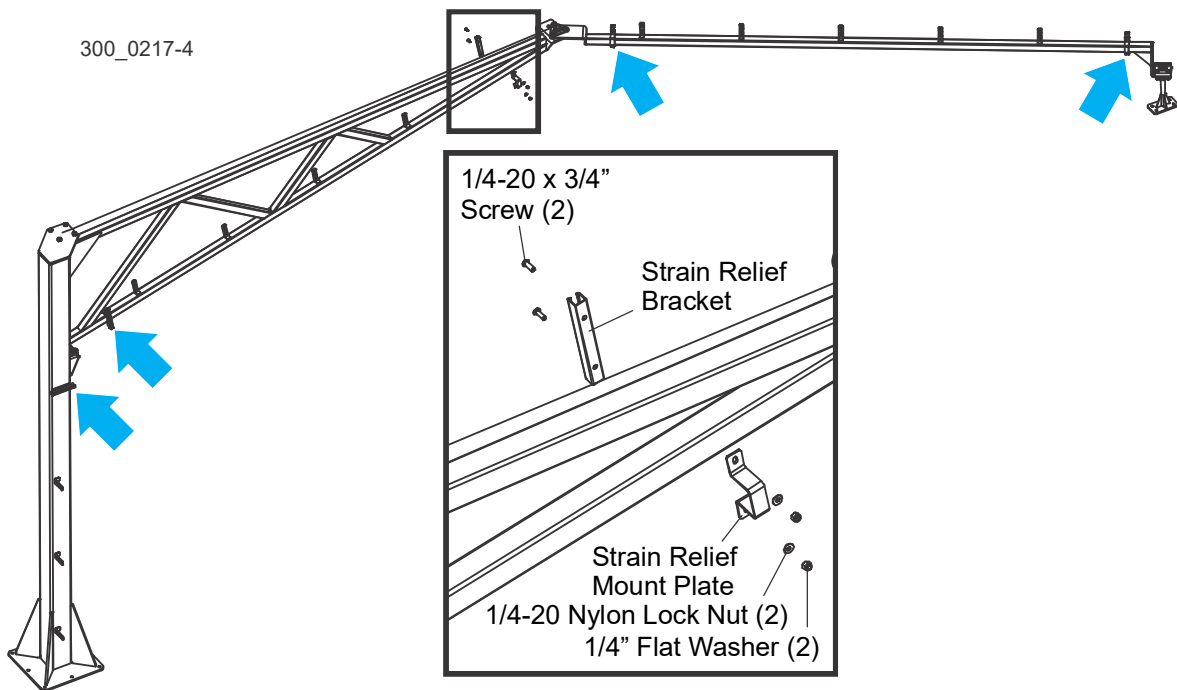

FIG. 3-10

- Assemble the strain relief brackets. (See Figure 3-10.)

11. Assemble the strain relief components to the strain relief brackets. (See Figure 3-11.)
12. Route all the cables and lines through the strain relief assemblies.
13. Tighten the strain relief screws to secure the cables and lines in place.

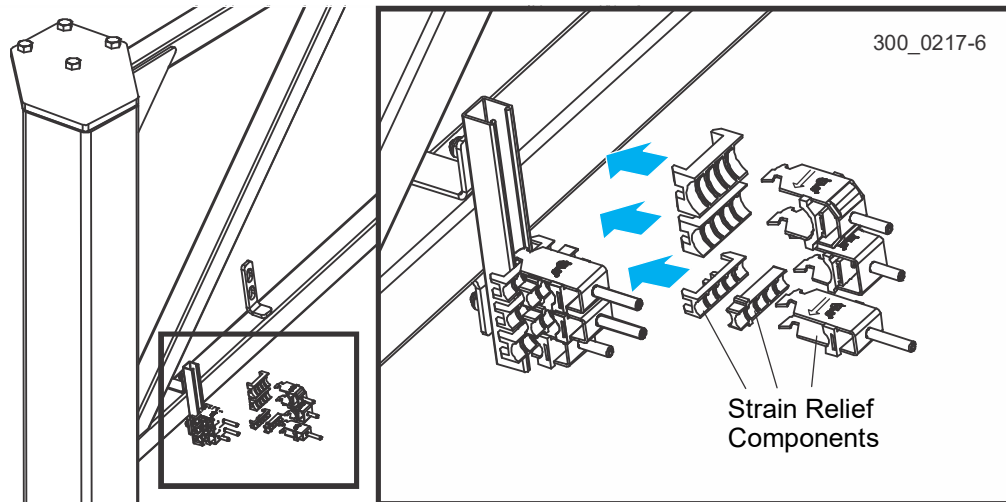

FIG. 3-11

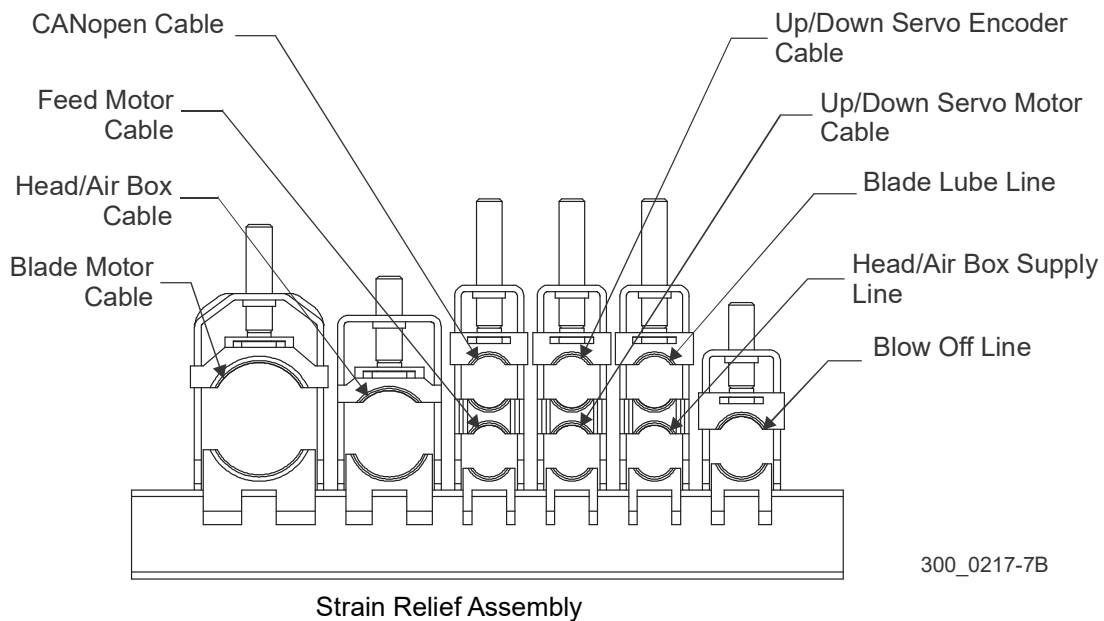

FIG. 3-12 STRAIN RELIEF LINE LOCATIONS

14. Use tie wraps to secure the cables and lines to the pantograph frame weldment.

3

Setup

Pantograph Cable Boom

NOTICE Ensure the cables and lines are looped at each end of the pantograph weldment to avoid damage when operating the sawmill. Make a larger loop between the pantograph assembly and the saw head for the saw head up/down movement. When pantograph electrical installation is finished, move the saw head to test the pantograph movement. Readjust the loop sizes as necessary.

3.6 Electrical Installation



DANGER! Make sure all electrical installation, service and/or maintenance work is performed by a qualified electrician and is in accordance with applicable electrical codes.

Electrical Requirements

The sawmill identification plate includes the required electrical information.

MFG BY: WOOD-MIZER LLC, 8180 W. 10th St. Indianapolis, IN 46214-2400 317/271-1542 or 800/553-0182							
SERIAL #	WM4500 0103002A1.00	FLA OF LARGEST LOAD	38A				
FLA	94.1A	IR	100kA	SCCR	5kA	VOLTS	480
	<small>(Base unit only)</small>					HZ	60
		PH	3				
ELECTRICAL DIAGRAM #	2018	PATENTS	<input style="width: 100%;" type="text"/>			<small>S20038</small>	
<small>300_0003C</small>							

IDENTIFICATION PLATE

NOTICE The sawmill is wired for use with a 480 volt power supply. To operate the sawmill with 240V, 400V or 600V power supplies an additional transformer is required. Table 3-1 lists transformers available from Wood-Mizer.

Conversion From/To	240 to 480 volts	400 to 480 volts	600 to 480 volts
Wood-Mizer Part No.	068057	068055	078214

TABLE 3-1

NOTICE Wood-Mizer also offers two phase generators: a phase generator without a motor starter (Part No. RPCNC40-230) and a phase generator with a motor starter (Part No. RPCNC40-230WS). These are the only supported phase generators Wood-Mizer offers. Many standard phase generators have known issues with Variable Frequency Drives. The 068057 transformer is required with the phase generator because the generator is 240VAC and has to be stepped up to 480VAC for the mill.

3 Setup

Installation

Installation

1. Position the main control box next to the operator station with enough room to open the box door and make the electrical connections.

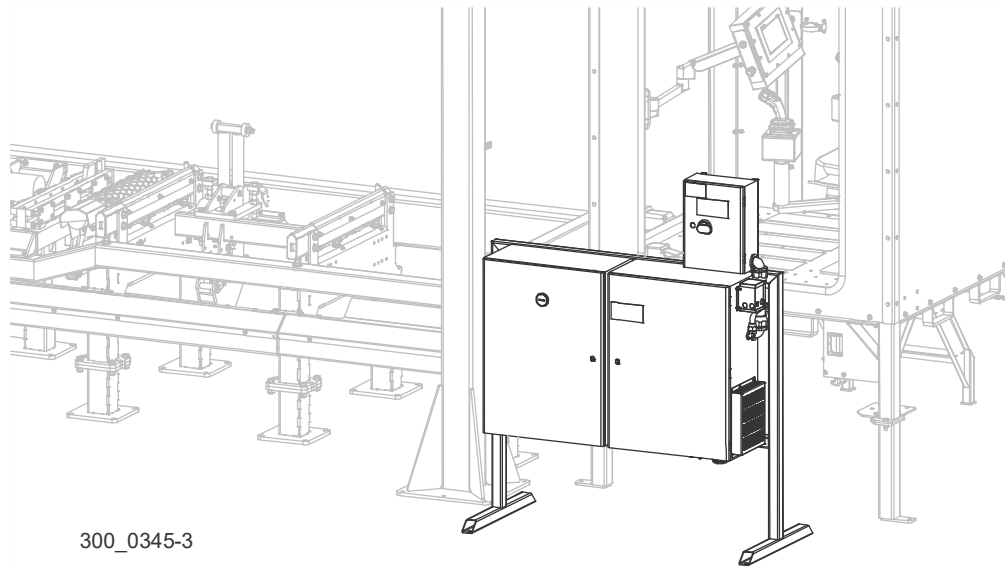

FIG. 3-12

2. Anchor the main control box to the floor with 1/2" anchor bolts and nuts.
3. Route the incoming power supply from the disconnect switch to the disconnect box, as shown in Figure 3-13.
4. Connect the power lines to terminals L1, L2, and L3 on the disconnect labeled Q1, as shown in Figure 3-13.

5. Connect the ground wire to the ground stud located at the corner of the box. See Fig. 3-13.

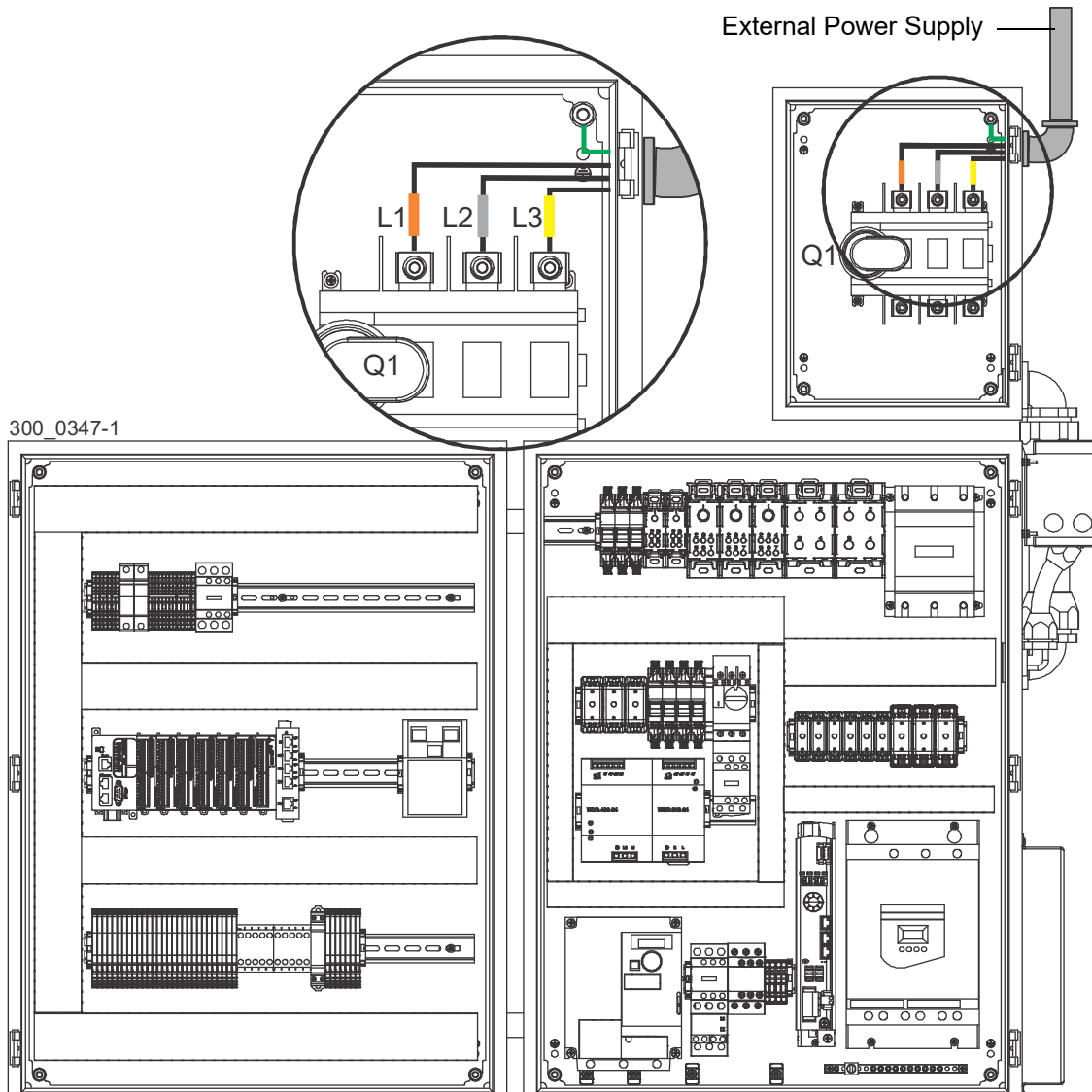

FIG. 3-13

6. Locate and identify each cable as shown in Table 3-2.

Cable	Function	Box Entry Location	Wire Number	Wire Color/Identifier	Termination Location (-Component ID.Terminal ID) (Terminal Strip ID-Terminal Block ID:Terminal ID) (-Component ID: Connector ID.Terminal ID)
W1	Blade Motor	L1.L3	GND	Green/Yellow	X3-1:2 (Ground Bar)
			403	Black U/L1/C/L+	-SSD1:T2
			404	Black V/L2	-SSD1:T1
			405	Black W/L3/D/L-	-SSD1:T3
			55B	Black 4	X2-1:2
			1004	Black 5	X2-2:2
W2	Hydraulic Pump Motor	L1.L3	GND	Green/Yellow	X3-1:4 (Ground Bar)
			412	1	-OL2:4/T2
			413	2	-OL2:2/T1
			414	3	-OL2:6/T3
W3	Feed Motor	L1.L3	GND	Green/Yellow	-VFD1:GND
			426	Black U/L1/C/L+	-VFD1:U/T1
			427	Black V/L2	-VFD1:V/T2
			428	Black W/L3/D/L-	-VFD1:W/T3
W4	Up/Down Servo Motor	L1.L3	GND	Green/Yellow	-SD1:CN10.GND
			445	Black L1	-SD1:CN10.U
			446	Black L2	-SD1:CN10.V
			447	Black L3	-SD1:CN10.W
			24	White	-SD1:CN11.BR+
			25	Gray	-SD1:CN11.BR-
W5	Up/Down Servo Encoder	L1.L3	--	--	-SD1:CN3
W20	Head	L1.L4	--	--	-J10
W21	Hydraulic Unit Control	L1.L4	--	--	-J12
W22	Operator Station Junction	L1.L4	--	--	-J13
W41	Lube Pump Motor	L1.L4	--	--	-J29
W103	Feed Encoder CANopen	L1.L4	--	--	-J66
W131	HMI Ethernet	L1.L4	--	--	-J96

TABLE 3-2

7. Insert or connect each cable in the main control, as shown in Figure 3-14.

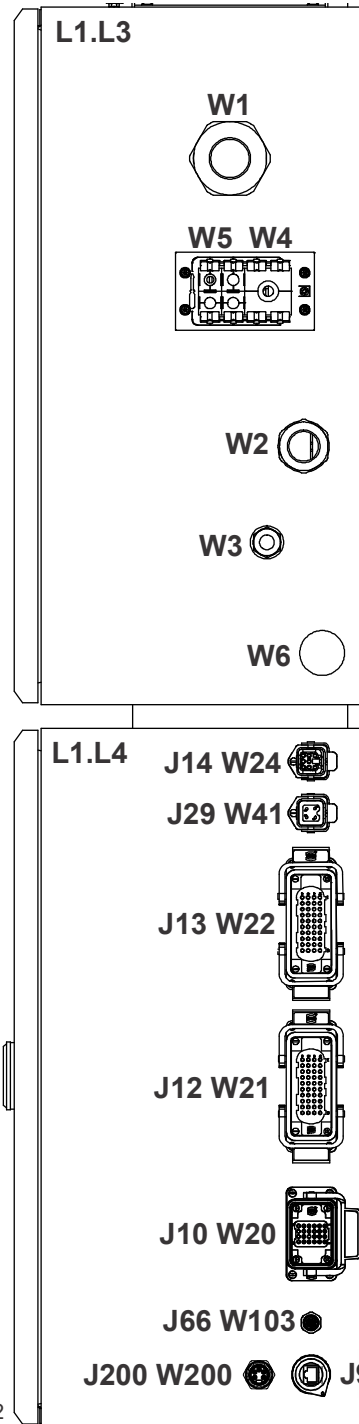

300_0237-2

FIG. 3-14 MAIN CONTROL BOX (BOTTOM VIEW)

8. Route each cable to the appropriate component or connector. Refer to the Electrical Information document, if necessary.

Blade Motor Cable (W1)

1. Route the blade motor cable (W1) through the connector W1 located at the bottom of the high voltage box and secure. See Fig. 3-15.
2. At drive SSD1 connect:
wire #403 to terminal SSD1:T2,
wire #404 to terminal SSD1:T1
wire #405 to terminal SSD1:T3.
3. At terminal block X2 connect
wire #55B to terminal X2-1:2 and
wire #1004 to terminal X2-2:2.

4. Connect the ground wire to the 2nd screw on the grounding bar.

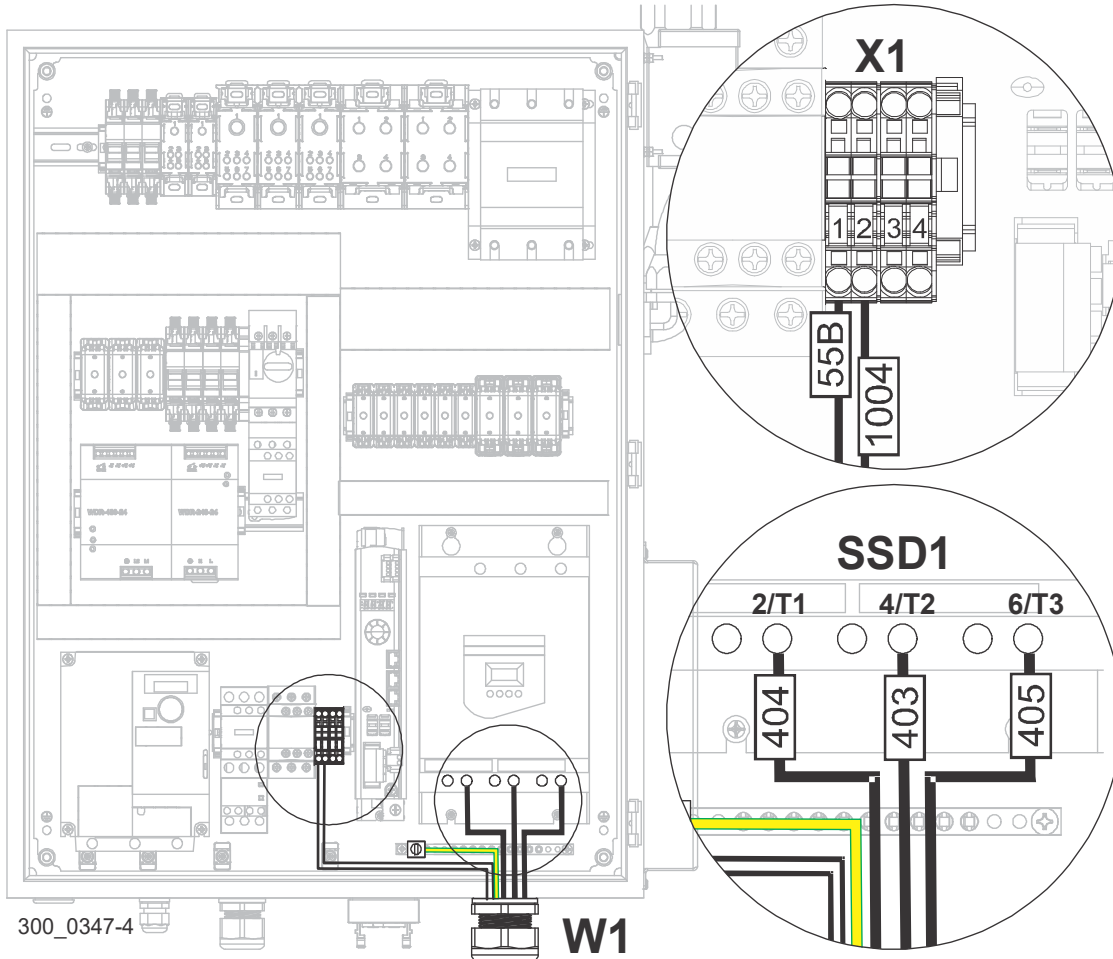

FIG. 3-15 HIGH VOLTAGE BOX

Hydraulic Pump Motor (W2)

1. Route the hydraulic pump motor cable (W2) through the connector W2 located at the bottom of the high voltage box and secure. See Fig. 3-16.
2. At overload OL2, connect:
 wire #413 to terminal OL2:2/T1,
 wire #412 to terminal OL2:4/T2, and
 wire #414 to terminal OL2:6/T3.

3

Setup

Feed Motor Cable (W3)

3. Connect the ground wire to terminal X3-1:4 of terminal block X3 (ground bar) and secure with screw 4 on the grounding bar.

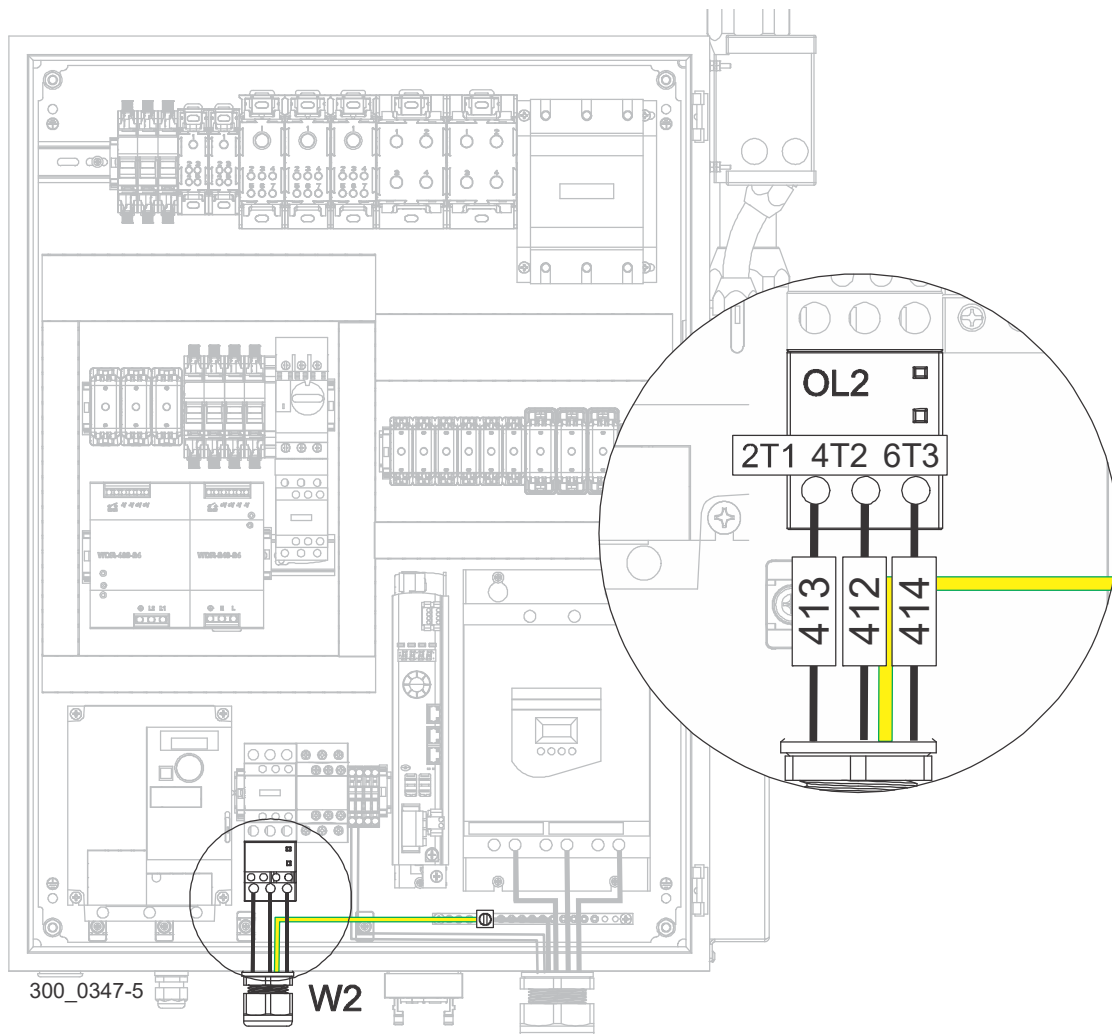

FIG. 3-16 HIGH VOLTAGE BOX

Feed Motor Cable (W3)

1. Route the feed motor cable (W3) through the connector W3 located at the bottom of the high voltage box and secure as necessary. See Fig. 3-17.
2. At feed drive VFD1, remove covers and connect wire #426 to terminal VFD1:U/T1, wire #427 to terminal VFD1:V/T2, and wire #428 to terminal VFD1:W/T3.

3. Connect the ground wire to terminal VFD1:GND.
4. Replace covers..

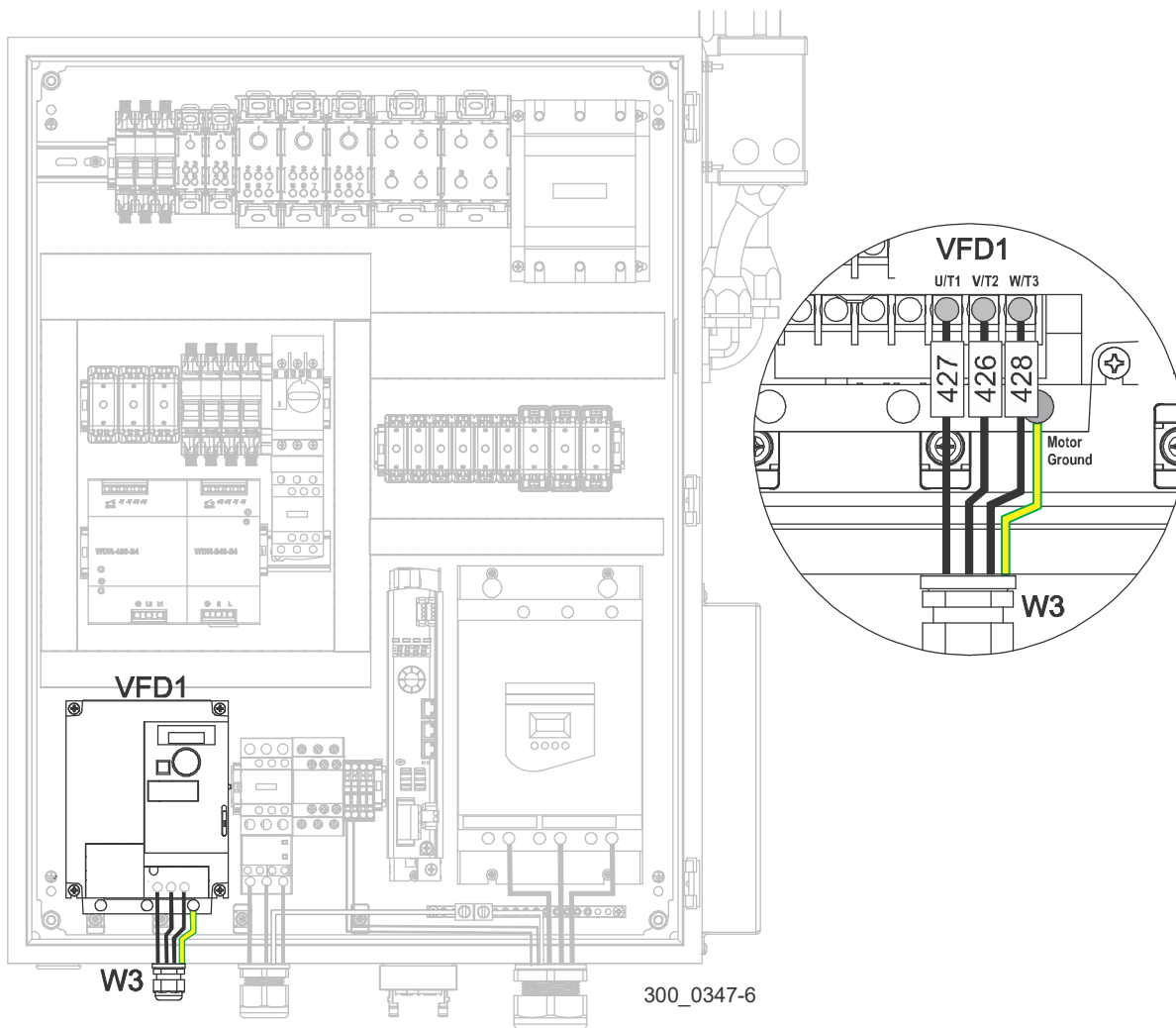

FIG. 3-17 HIGH VOLTAGE BOX

Up/Down Servo Motor Cable (W4)

1. Route the up/down servo motor cable (W4) through the connector labeled W4 located at the bottom of the high voltage box.
2. At up/down drive SD1, connect wire #445 to terminal SD1:CN10.U, wire #446 to terminal SD1:CN10.V, wire #447 to terminal SD1:CN10.W,

3

Setup

Up/Down Servo Encoder Cable (W5)

wire #24 to terminal SD1:CN11.BR+, and
wire #25 to terminal SD1:CN11.BR-.

3. Connect the ground wire to terminal SD1:CN10.GND.

Up/Down Servo Encoder Cable (W5)

1. Route the up/down servo motor cable (W5) through the connector labeled W5 located at the bottom of the high voltage box. See Fig. 3-18.
2. Connect the cable to terminal SD1:CN3 of the up/down drive SD1.

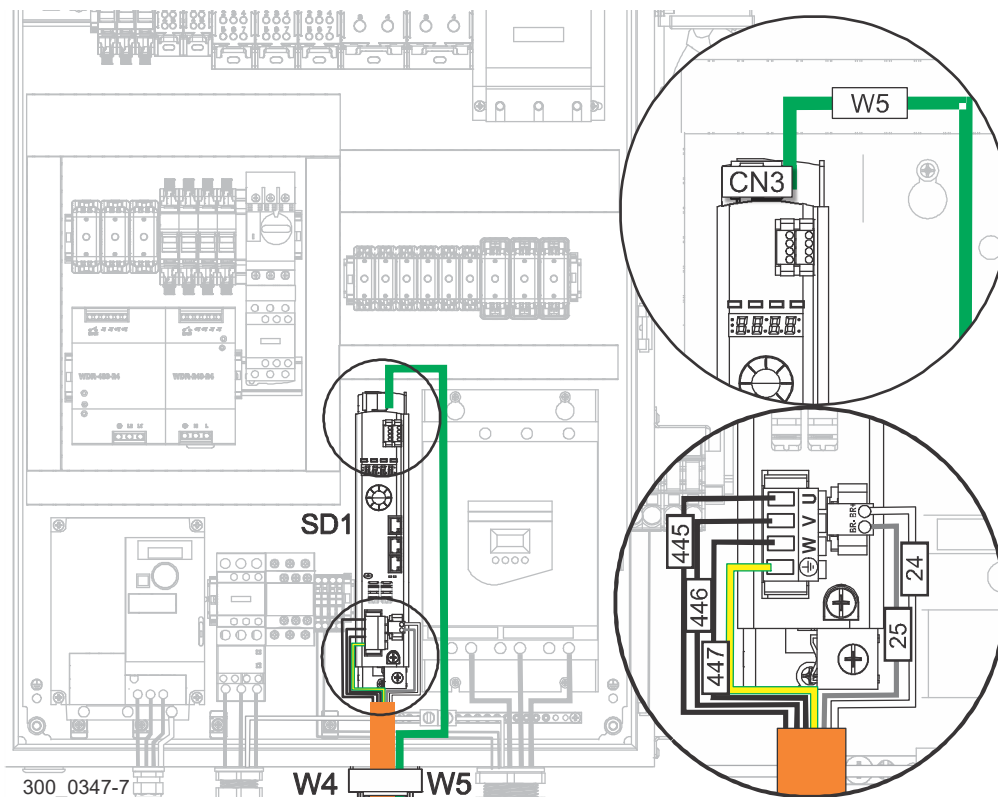

FIG. 3-18 HIGH VOLTAGE BOX

Low Voltage Box Cables (W20-22, W41, W103 and W131)

1. At the low voltage box, connect:
 - head cable (W20) to the connector labeled J10 W20 at the bottom of the box.
 - hydraulic unit control cable (W21) to the connector labeled J12 W2

- operator station junction cable (W22) to the connector labeled J13 W22.
- lube pump motor cable (W41) to the connector labeled J29 W41
- feed encoder CANopen cable (W103) to the connector labeled J66 W103
- HMI Ethernet cable (W131) to the connector labeled J96 W131. See Fig. 3-19.

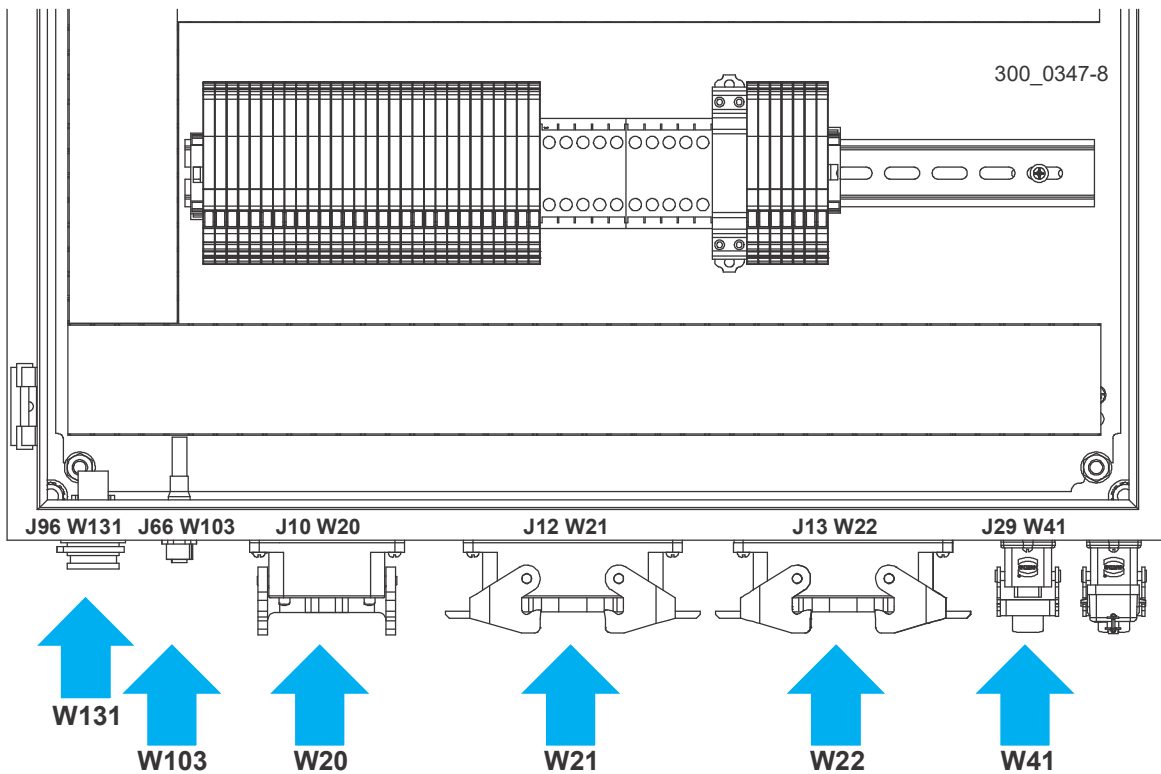

FIG. 3-19 LOW VOLTAGE BOX

3.7 Bio-Lube Installation

The Bio-Lube system lubricates the blade and blade wheels only while the blade is running. Blade lubrication increases the blade life and performance See Fig. 3-20. .

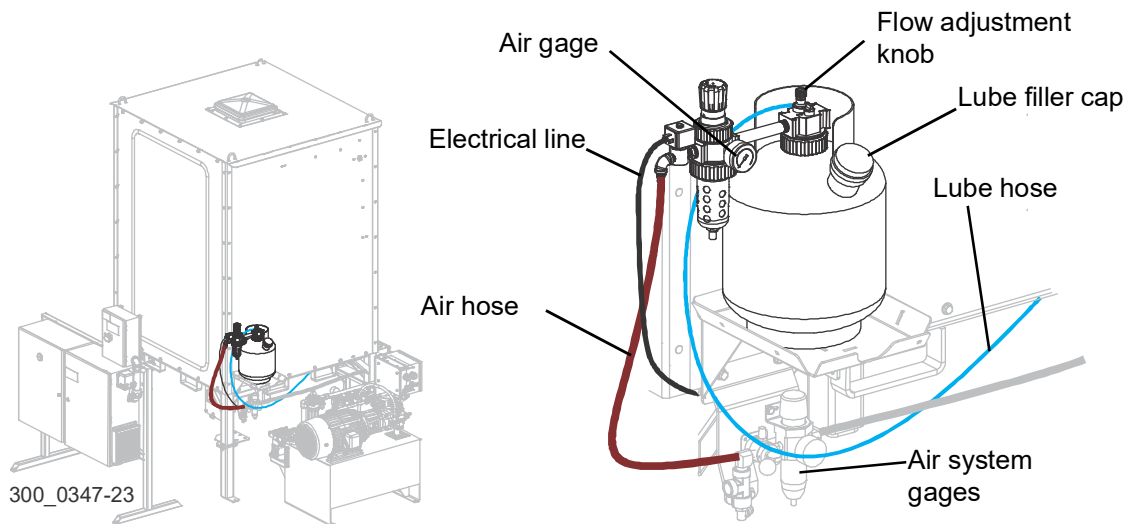

FIG. 3-20

1. Place the tank on the shelf, as shown in Figure 3-20.
2. Attach the system air supply to the tank gage.

Begin with an air pressure setting between 30-40 PSI (2.1 - 2.8 Kg/cm). The combination of air and lube should be adjusted according to the type of wood being cut. The flow should be enough to keep the blade and the wheels free of buildup.

3. Attach the electrical line to the transducer fitting.
4. Attach the lubricant hose to the tank top fitting.

NOTE: The lubricant line routes through the pantograph to the manifold under the distribution box on the saw head.

5. Fill the tank with lubricant.

The lube flow is adjustable from drip to constant flow. The combination of air and lube should be adjusted according to the type of wood being cut. The flow should be enough to keep the blade and the wheels free of buildup.

The flow may be fine tuned by the lubricant manifold, located below the distribution box on the saw head. See Fig. 3-21.

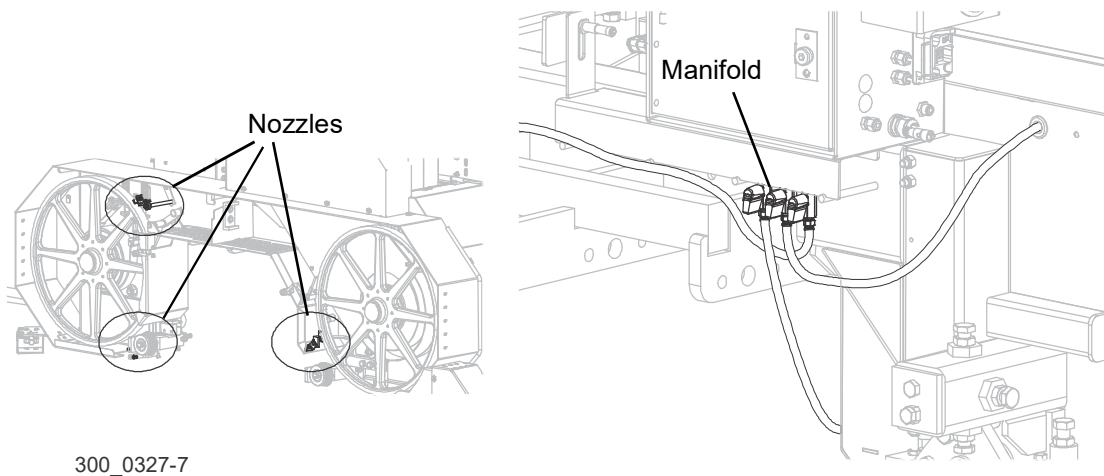

300_0327-7

FIG. 3-21

3.8 Hydraulic Installation

NOTE: See [SECTION 8 Hydraulic Information](#) for detailed information.

1. Position the hydraulic power unit approximately 12" away from the operator station and approximately centered, as shown in Figure 3-22. See Fig. 3-22.

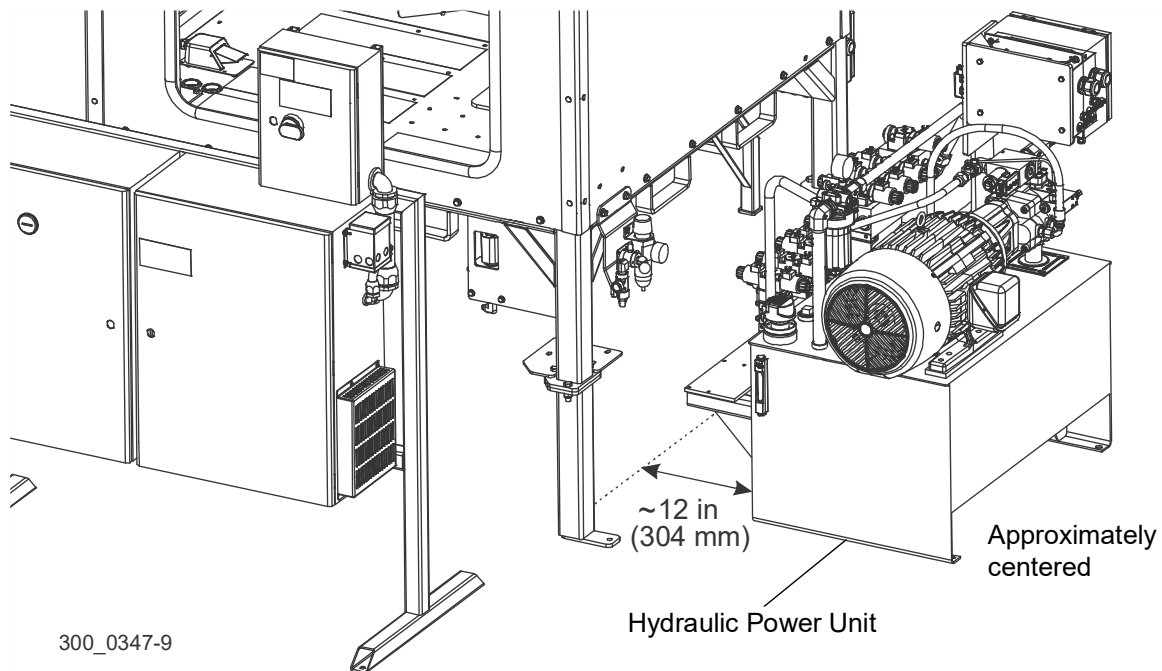

FIG. 3-22

2. Anchor the hydraulic power unit to the floor with 1/2" anchor bolts and nuts.
3. Remove the plugs from the hydraulic power unit fittings.
4. Identify the color-coded hoses extending from the sawmill frame.

- Remove the plugs from the hoses and connect each hose to the appropriate fitting on the hydraulic power unit. See Fig. 3-23 and Fig. 3-24.

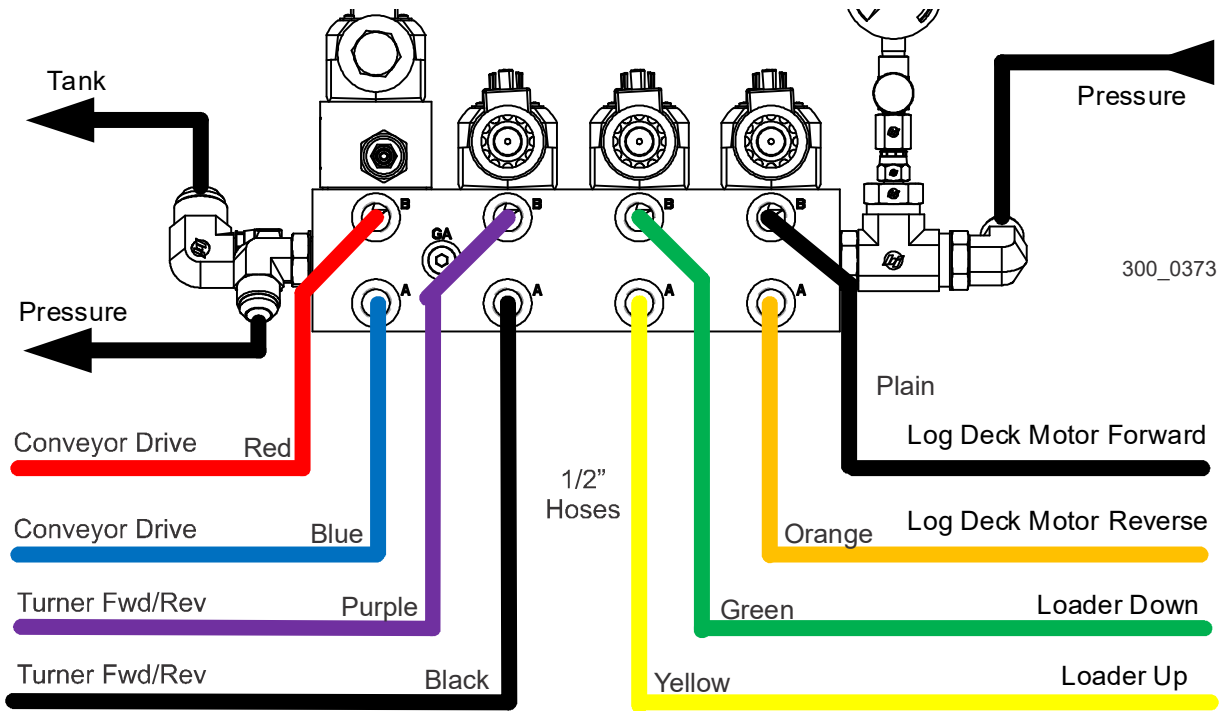

FIG. 3-23

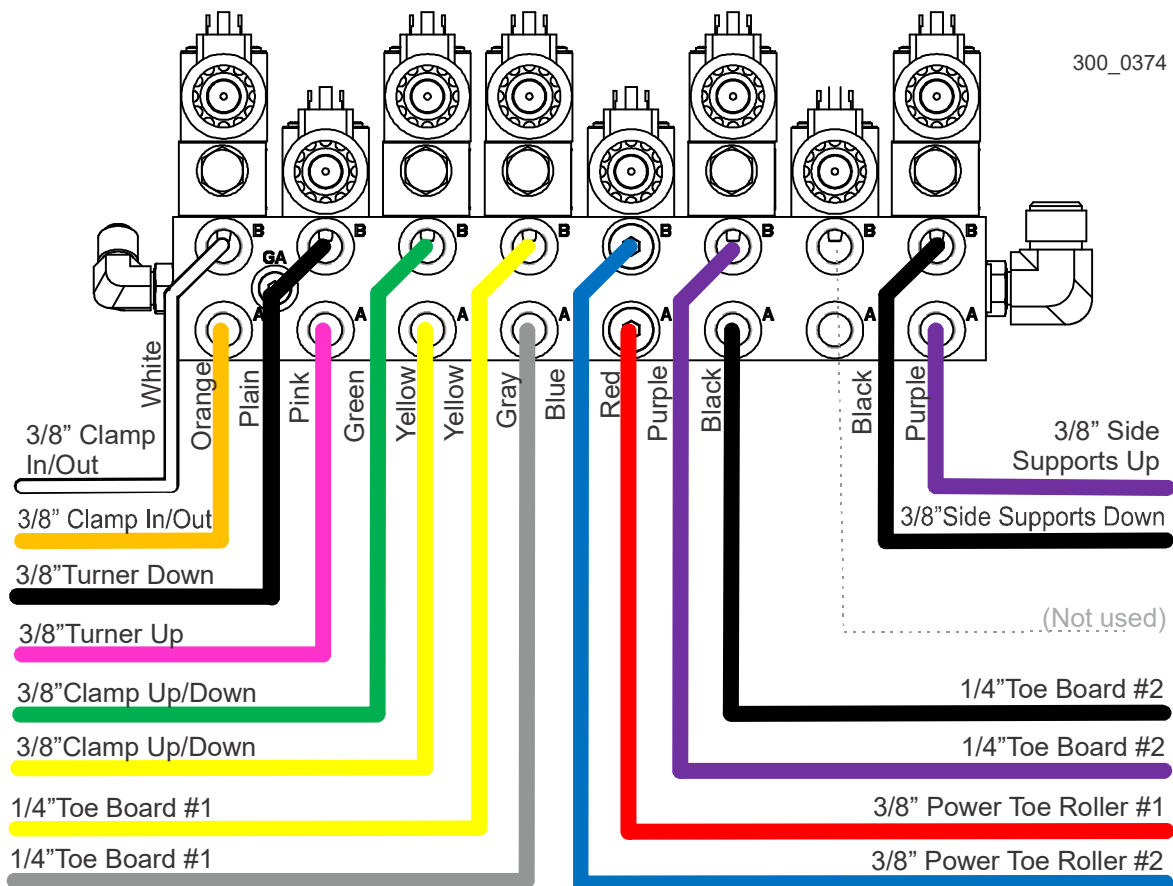

FIG. 3-24

6. Remove the plugs from the turner down flow divider located on to the operator station leg. See Fig. 3-25.
7. Remove the plugs from the two short hoses extending from the sawmill frame.
8. Connect the hoses to the fittings on the turner down flow divider. See Fig. 3-25.

NOTE: Either of the two hoses can be connected to the top or the bottom fitting on the divider.

9. Remove the plug from the short hose extending from the hydraulic power unit.

10. Connect the hose to the fitting on the turner down flow divider.

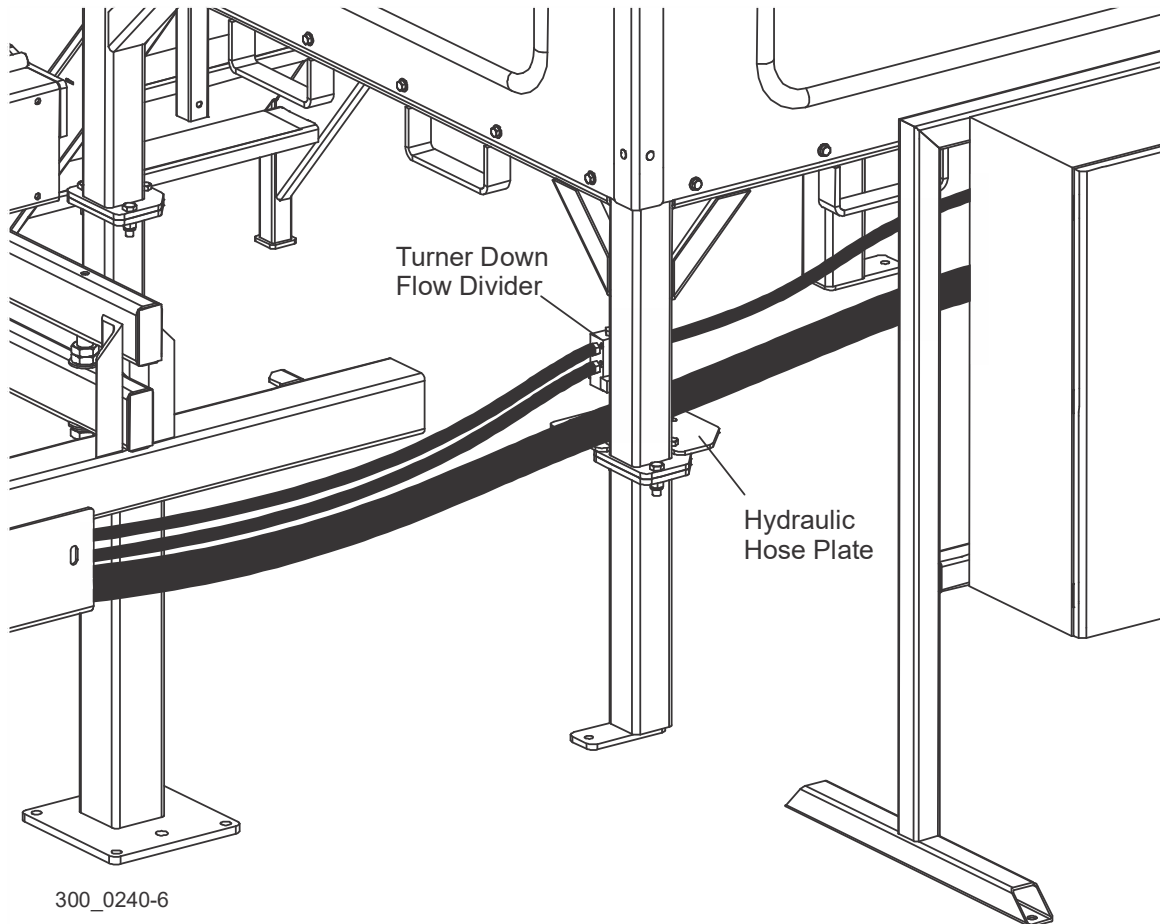

FIG. 3-25

11. Use the tie wraps to secure the hydraulic hoses to the hydraulic hose plates located on the operator station.
12. Remove the plugs from the four color-coded hoses secured to the hydraulic hoses next to the hydraulic log clamp.

3

Setup Hydraulic Installation

13. Connect each hose to the appropriate fitting on the hydraulic log clamp. See Fig. 3-26.

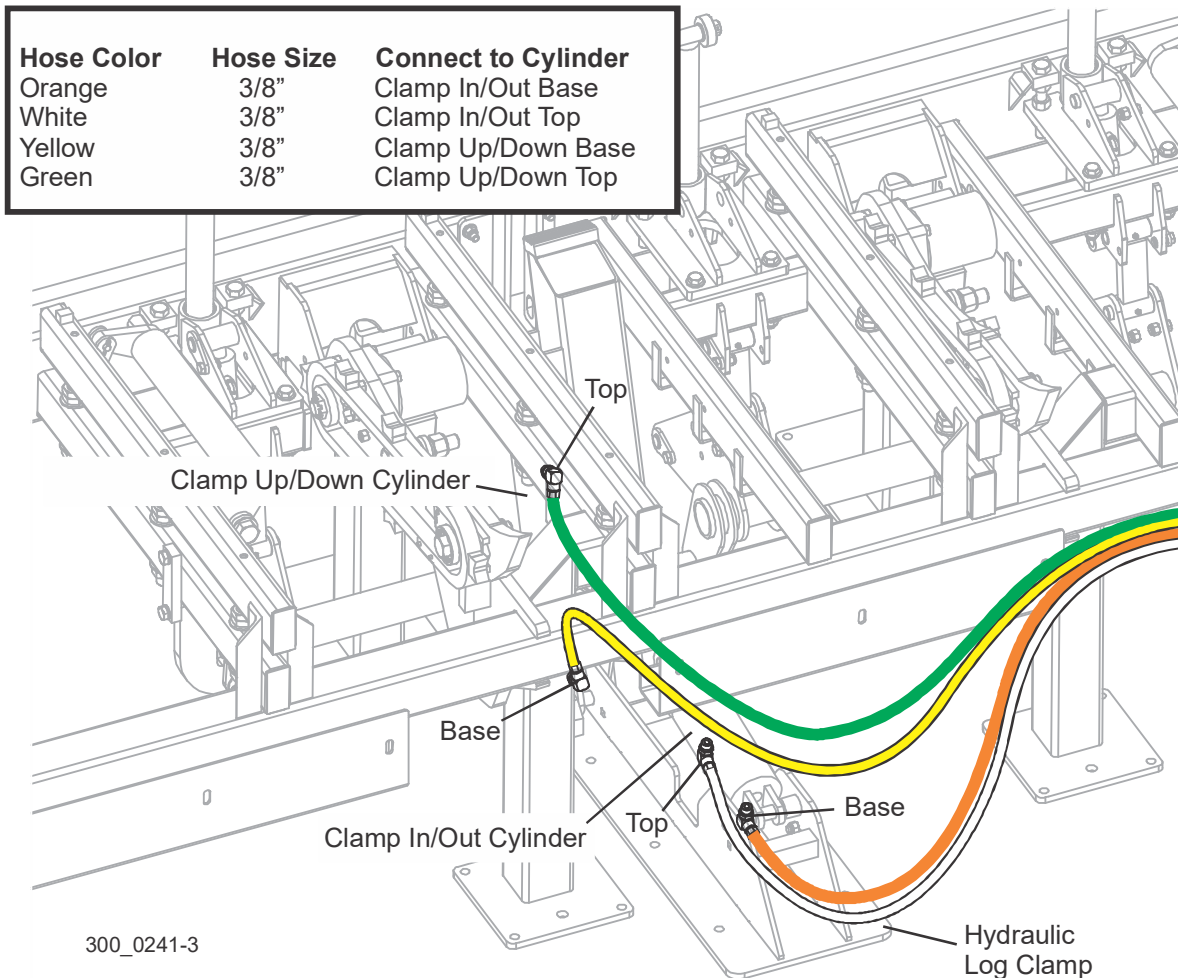

FIG. 3-26

See [SECTION 8](#) for hydraulic schematics and components.

NOTICE The pressure gauge is used for troubleshooting purposes only. Close the hydraulic power unit pressure gauge valve to isolate the pressure gauge from the hydraulic circuit during normal machine operation.

Hydraulic Installation (Optional BX12 Bed Extension Only)

1. Install the bed extension hydraulic control box and valve assembly to the operator station, as shown in Figure 3-27.
2. Secure the assemblies to the operator station.

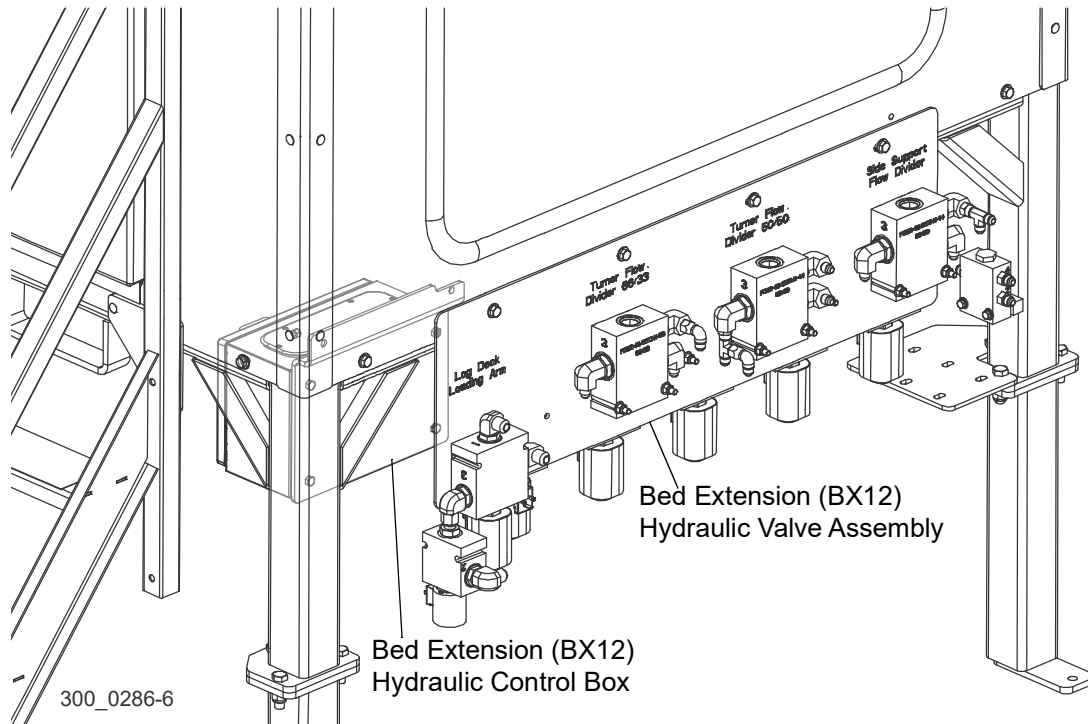

FIG. 3-27

3

Setup

Hydraulic Installation (Optional BX12 Bed Extension Only)

3. Install the bed extension directional valve assembly to the hydraulic power unit, as shown in Figure 3-28.

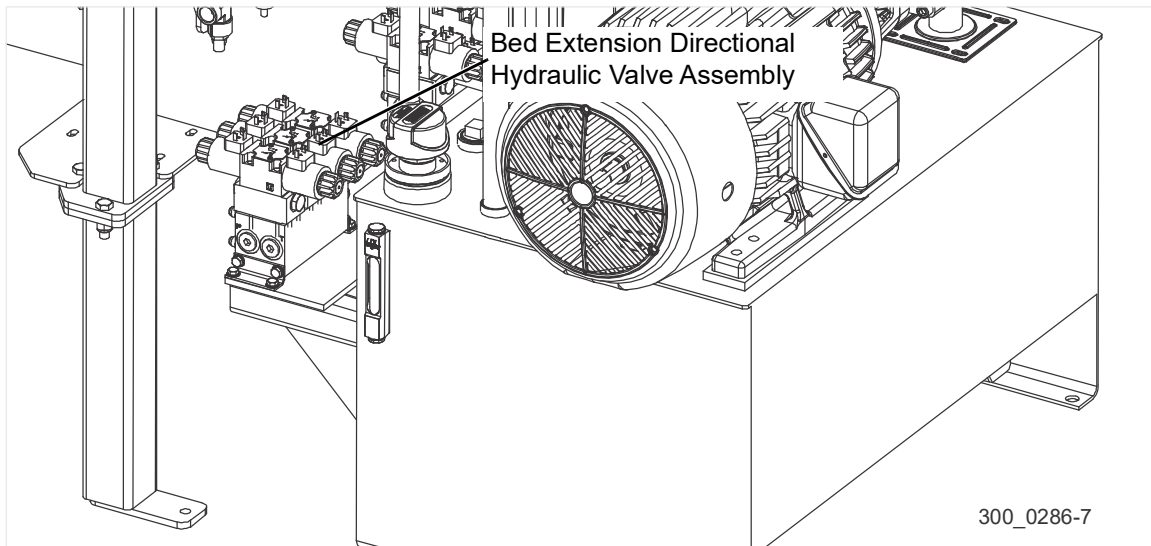

FIG. 3-28

4. Connect the bed extension hydraulic hoses to the bed extension hydraulic components and valve assemblies ([See Section 0.1](#) for BX12 bed extension hydraulic schematic).

See [4.1 Overview](#) to enable the BX12 bed extension option and its hydraulic system in the control box.

3.9 Air Installation

1. Install a 1/2" NPT quick disconnect fitting to the fitting supplied in the air valve at the rear of the operator station. See Fig. 3-29.
2. Connect the incoming air supply line (minimum 1/2" air hose) to the quick disconnect fitting.
3. Connect the two air lines from the sawmill to the tube fittings supplied on either side of the air regulator/filter.
4. Install the line labeled "Blow-Off Supply" to the fitting to the left of the air valve and regulator.
5. Install the line labeled "Tension Air Supply" to the elbow fitting on the regulator; install lines by pushing in the fitting collar, inserting the hose, then releasing the collar.

NOTE: If the sawmill is equipped with the optional Pressure Lube System, connect the 1/2" Blow-Off Supply line to the lube system fitting and connect the 1/2" hose from the lube system to the fitting to the left of the air valve ([See Section 3.6.2](#)).

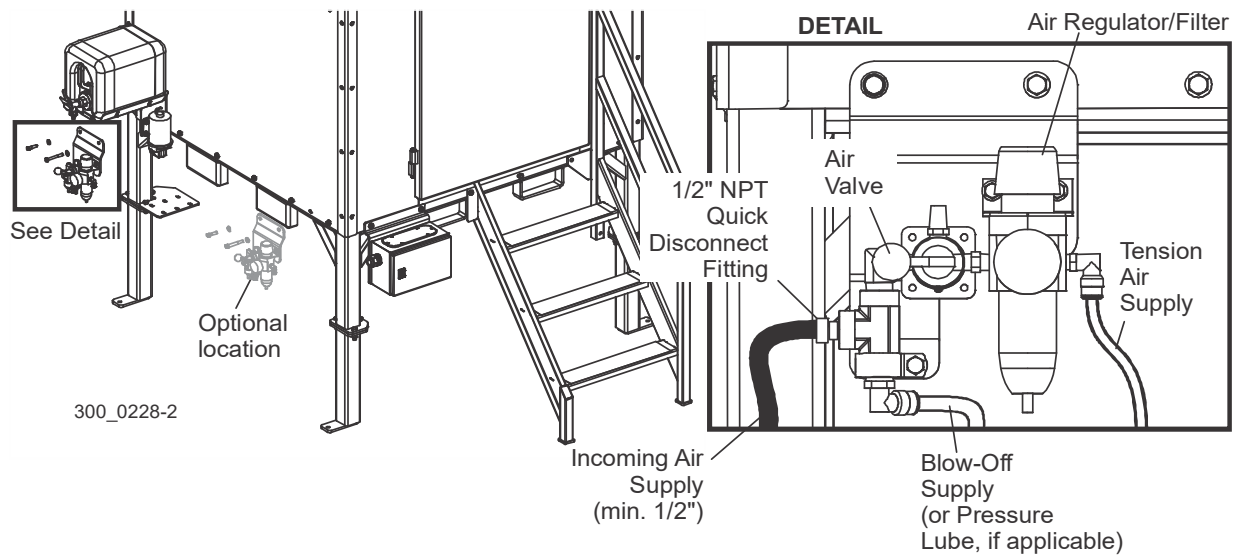

FIG. 3-29

3.10 Sawmill Installation Setup

Once the sawmill is in place and anchored to the floor, you are ready to setup the sawmill for operation. The first step should be aligning the sawmill bed sub-frame. A transit maybe used for this procedure, however a laser-style level is recommended because it is easier and more accurate.

NOTE: This procedure is intended to be performed by factory personnel during initial installation using the appropriate equipment. Refer to the alignment section for subsequent adjustments to sawmill ([See SECTION 6 Alignment](#)).

Level Sub-Frame

1. Move the saw head so it is positioned over the log clamp tube at the middle of the bed frame.



CAUTION! Avoid raising or lowering the saw head against the upper or lower travel limits until after the transducer has been properly adjusted. Failure to do so may result in damage to the machine.

2. Set the laser level beam five inches above the top track rail.
3. Measure the distance from the top track rail to the laser beam at four equal locations along the tube.
4. Once you have four measurements, determine a target dimension that splits the difference of the four dimensions taken.

EXAMPLE: Four dimensions from track rail to the laser beam are as shown in Table 3-3. The 1/4" (6mm) dimension (mode) should be the target as this will require the least adjustment at each location.

Front	Front Middle	Rear Middle	Rear	Target
1/4" (6mm)	0"	1/2"	1/4" (6mm)	1/4" (6mm)

TABLE 3-3

5. Measure the distance from the top track rail to the laser beam at one of the leg locations.
6. Move the saw head as necessary to remove weight from the leg.
7. Use the shims to raise or lower the appropriate leg until the target dimension is obtained ($\pm 1/16"$ (1.5mm)).

8. Repeat at each leg location along the length of the main bed tube. See Fig. 3-30.

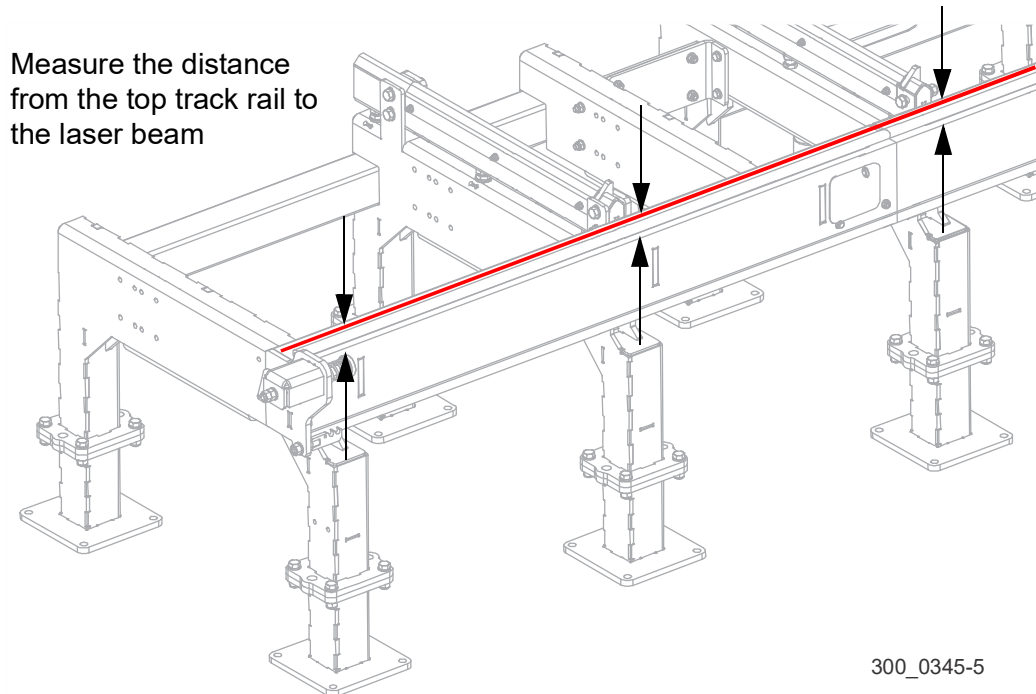

FIG. 3-30

9. Move the saw head back to the rear of the bed (furthest from operator station).
10. Measure the distance from the top track rail to the laser beam at the bed rail location.

If the measurement is more than 1/16" (1.5mm) more or less than the target dimension determined above, shim one of the two middle inside legs to push or pull the tube until it is level.

CROSS RAIL LEVELING

11. Place two pieces of straight tubing between the front two bed rail supports.
12. Measure from the front end of each tube to the laser beam.
13. Shim the outer front leg to level the bed so both measurements to the tubes are the same ($\pm 1/16"$ (1.5m)).
14. Repeat at the other end of the tubes using the second outer leg to adjust.

3 Setup

Level Saw Head

15. Move the straight tubes to the rear two bed rail supports and adjust the two outer rear legs until the bed is level ($\pm 1/16"$ (1.5m)). See Fig. 3-31.

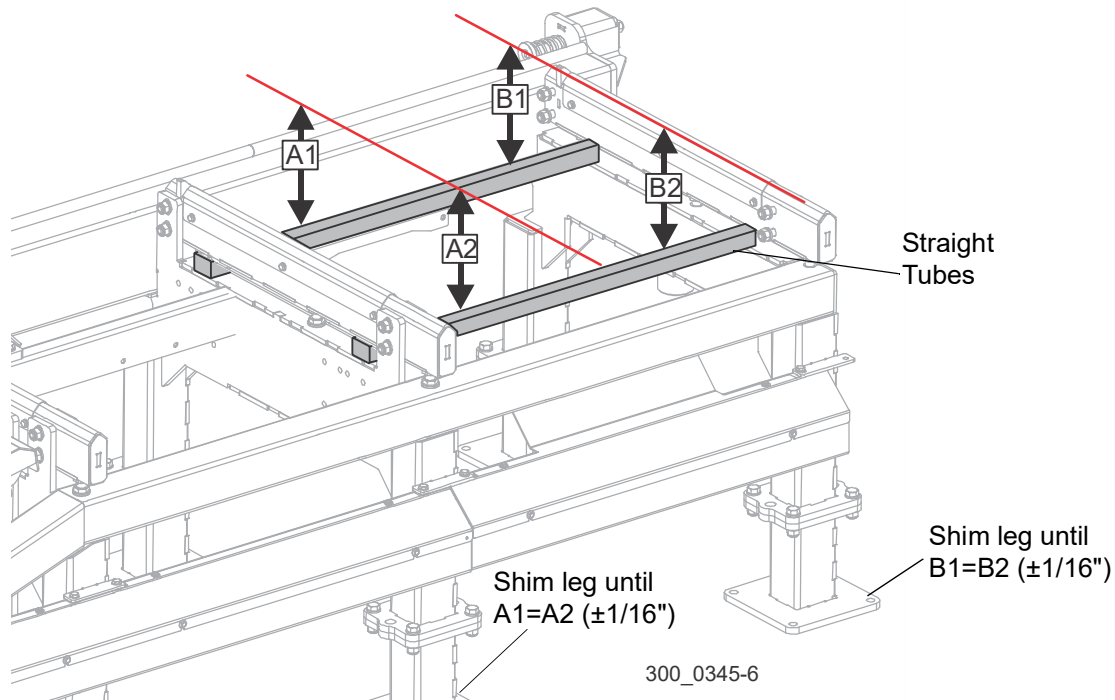

FIG. 3-31

Level Saw Head

1. Install, tension, and track a blade according to [Section 6.6 Installing A Blade](#).



WARNING! Do not use blades with stress cracks. Blades with stress cracks may shatter causing severe injury and/or death.

2. Set a laser level beam at the log clamp location, parallel to the bed rails.
3. Adjust the blade guide arm all the way out.

4. Loosen the blade guide adjustment screws as necessary to move blade guide roller away from blade. See Fig. 3-32.

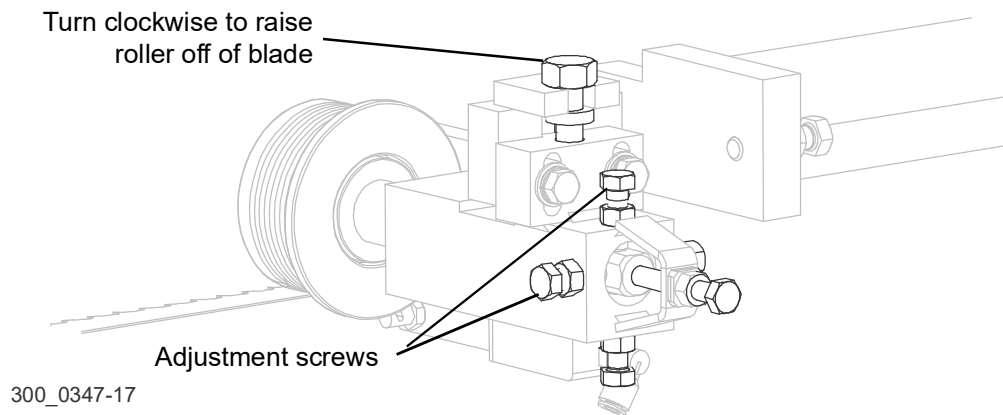

FIG. 3-32

5. Ensure that the blade guide roller does not touch the blade.
6. Raise the saw head until the blade measures 15" (380mm) above the laser level beam.
7. Measure the distance (with a tape or rule) from the bottom of the blade to the laser beam at the **inner** blade guide.



IMPORTANT! Make sure the tape does not contact an upward set tooth.

8. Measure the distance (with a tape or rule) from the bottom of the blade to the laser beam at the **outer** blade guide.

3 Setup

Level Saw Head

NOTE: The two measurements should be equal. If necessary, adjust the lower track rollers to tilt the saw head so the blade is parallel to the laser beam. See Fig. 3-33 and 3-34.

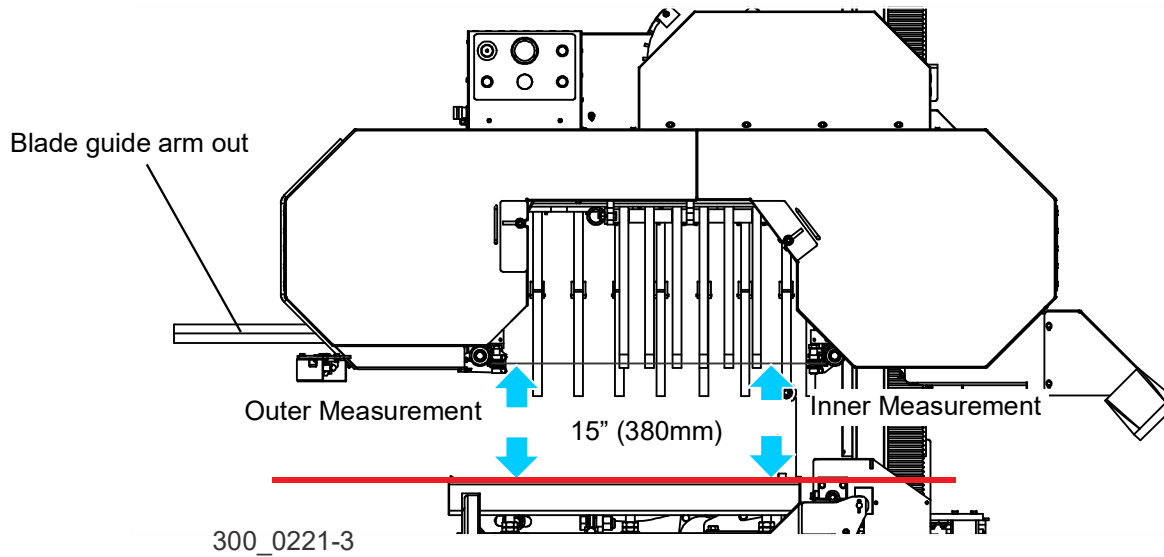

FIG. 3-33

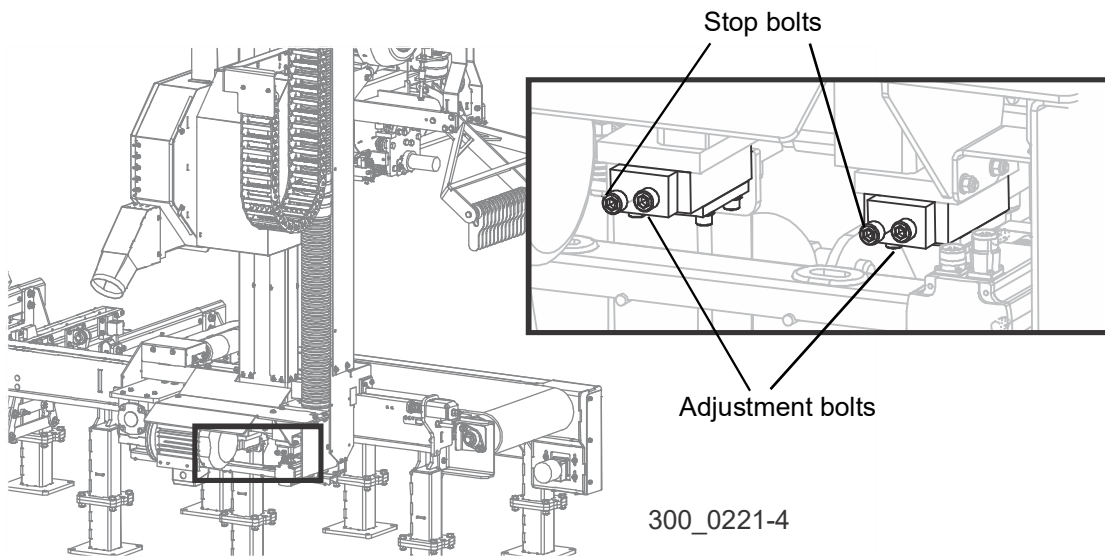

FIG. 3-34

9. Tilt the outer side of the saw head up or down toward the bed by loosening the adjustment bolts.

- a. Loosen the stop bolts.
- b. Turn each adjustment bolt one revolution.
- c. Remeasure the distance from the blade to the laser beam until the blade is parallel to the beam.
- d. Tighten the stop bolts against the roller mount block.

The blade is now parallel to the bed rails at the clamp location, which is your now your base measurement.

10. Repeat the alignment at each leg location along the main frame tube.
 - a. Move the saw head to the first leg location to measure from the blade to the laser beam at both blade guide assemblies. See Fig. 3-33.
 - b. If the measurements are not the same, shim the outer leg until the blade is parallel to the laser beam.
 - c. Repeat adjustment at each leg location down the length of the frame tube.
 - d. Return to the first leg, recheck the blade alignment.
 - e. Repeat as necessary.

- f. Return to the first leg, recheck the blade alignment, fine-tune as necessary. See Fig. 3-35.

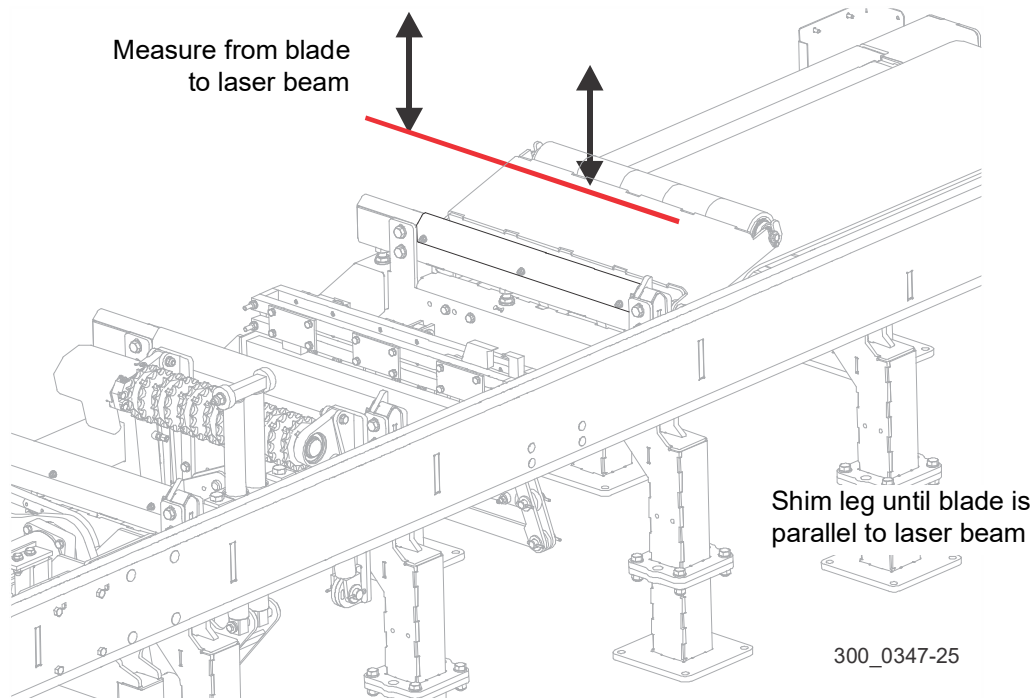

FIG. 3-35

Level Bed Rails

1. Adjust the bed rails to 1/2" (13mm) below the log clamp stop. See Fig. 3-36.
2. Measure the distance from the laser beam to the clamp stop.
3. Measure the distance from the first bed rail to the laser beam at both ends of the bed rail.
4. If necessary, loosen the bed rail adjustment nuts and turn the adjustment nuts to raise or lower the end of the bed rail so it is 1/2" below the clamp stop (i.e. 5 1/2" (140mm) \pm 1/16" (1.5mm)).
5. Retighten the bed rail adjustment nuts.

- Repeat adjustment as necessary at each bed rail. See Fig. 3-36.

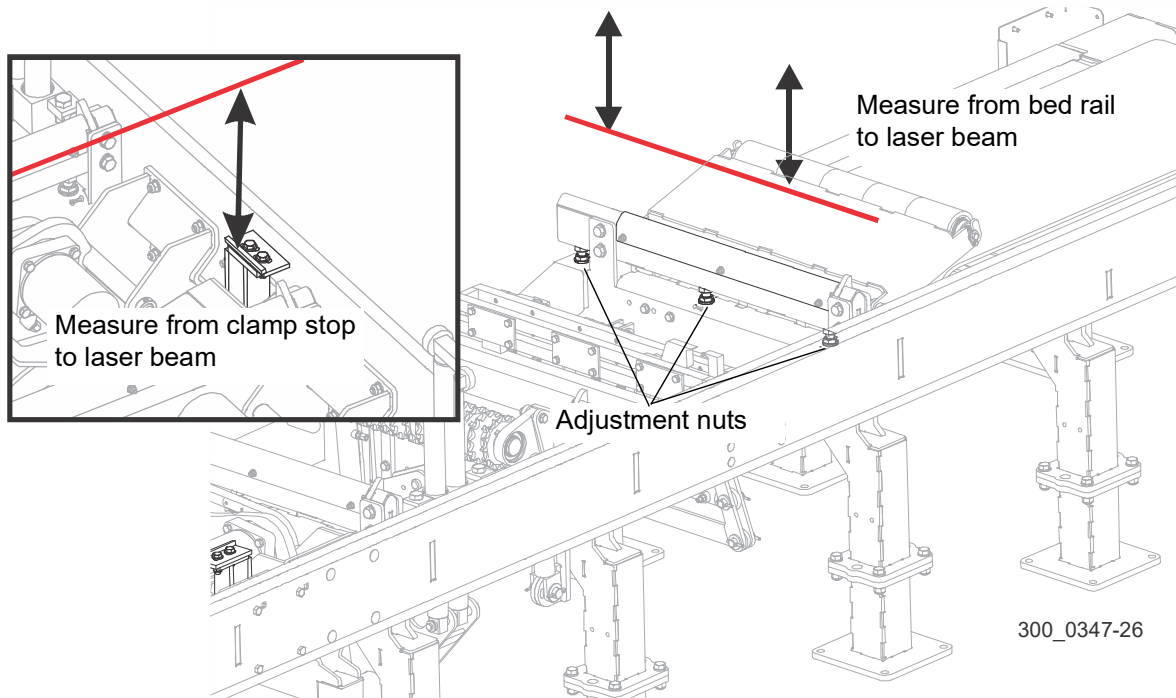

FIG. 3-36

- Move the saw head so the blade is positioned over the first bed rail.
- Open the blade guide arm all the way open.
- Measure from the bottom of the blade to the bed rail at each end of the rail.

If the two measurements differ by more than 1/16" (1.5mm), recheck the measurement from the bed rail to the laser beam and adjust the bed rail as necessary.

- Move the saw head to each bed rail and repeat procedure until all bed rails are parallel to the blade and laser beam within 1/16" (1.5mm).

Level Blade Guide Arm

- Adjust the blade guide arm all the way in.
- Measure from the bottom of the arm to the laser beam at both ends of the arm.

3

Setup Level Blade Guide Arm

3. The two measurements at each end of the arm should be the same within 1/32" (0.8mm).
4. Adjust the bolts (C & D) on the blade guide arm mounting plate for the vertical tilt.
5. Loosen the jam nuts.
6. Adjust bolt (C) up and bolt (D) down to tilt the arm up.
7. Adjust bolt (D) up and bolt (C) down to tilt the arm down.
8. Recheck the distance from the arm to the laser beam at both ends of the arm.
9. Readjust as necessary.
10. Tighten the jam nuts. See Fig. 3-37.

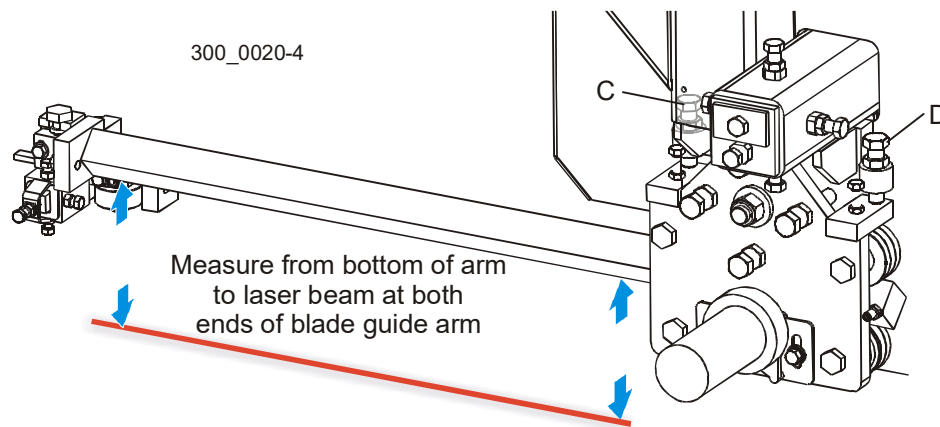

FIG. 3-37

Adjust the blade guides for sawing

1. Move the guide assembly forward until the roller flange is 1/16" (1.5mm) - 1/8" (3mm) from the back edge of the blade and tighten clamp bolts. See Fig. 3-38.

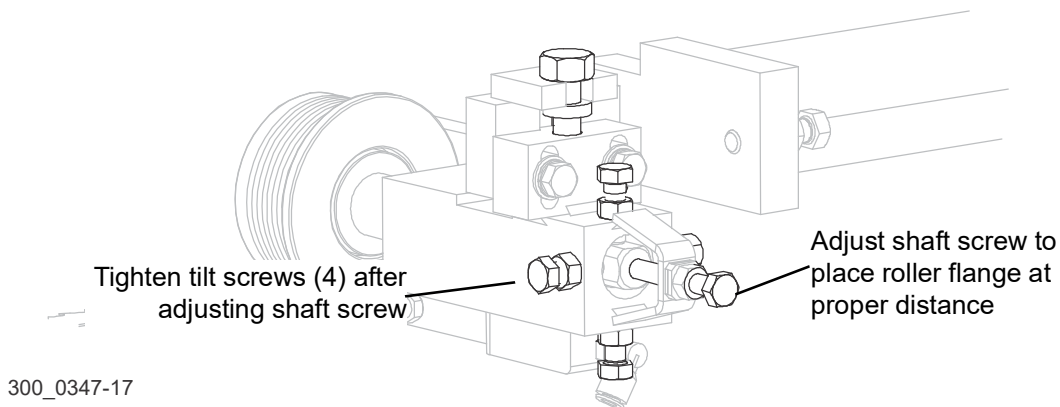

FIG. 3-38

2. Turn blade guide assembly bolt counterclockwise to lower the guide roller until it deflects the blade down 1/4" (6mm).
3. Repeat for other blade guide assembly. See Fig. 3-39.

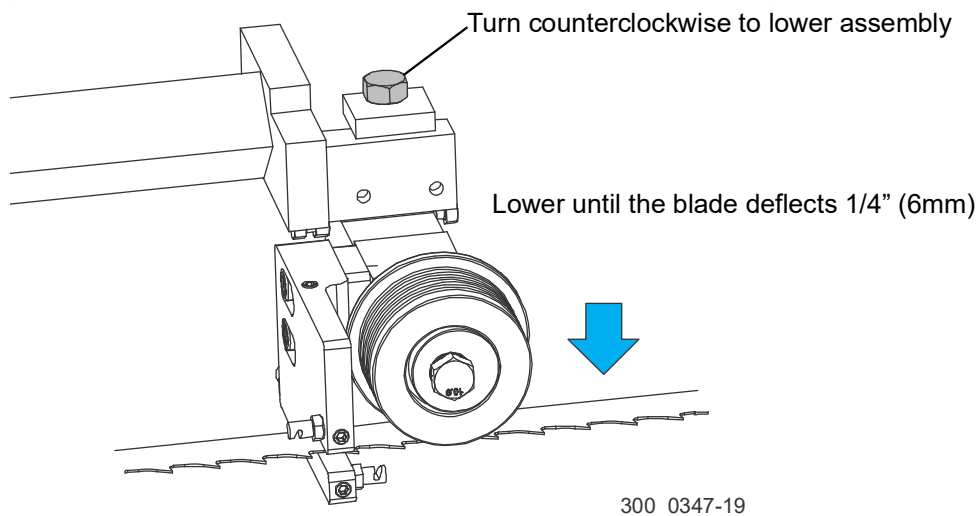

FIG. 3-39

3.11 Networks setup

Familiarize yourself with Networks by reading [Section 4.1 Overview](#), then follow [Section 4.4 Initial Sawmill Setup](#)

3.12 Initial Sawmill Setup

NOTICE If you have not familiarized yourself with the Networks screens, please refer to Section 4.x Networks Overview.

Installation Configuration

1. Release the emergency stop and push the control power-on green START button to activate the machine. ([See Section 6.5.](#))

NOTE: A pop-up window with a progress bar scrolling appears while communication is being established with the drive and it is being put into the operating state.

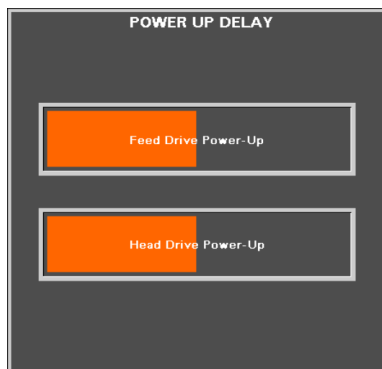

2. Press the **Setup** button on the Main Screen to enter the Setup (Options) screen.
3. Select the units of measure for your operation.

3 Setup Installation configuration

4. Press **Install Config.** to go to the next screen.

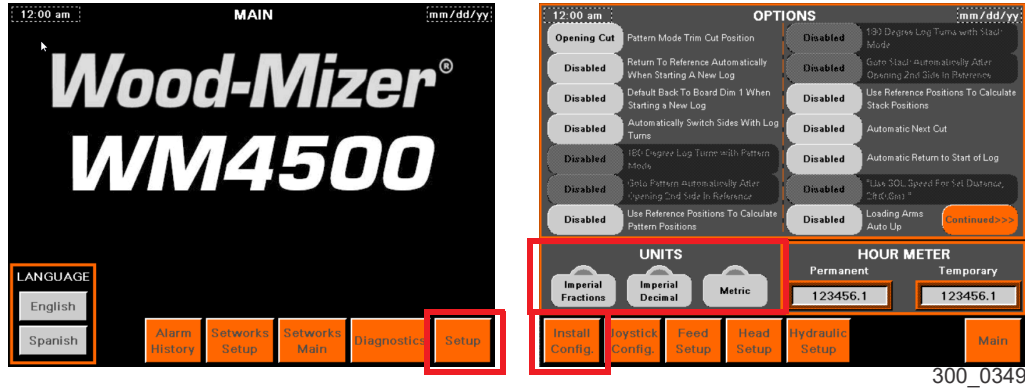

FIG. 3-39

Installation configuration

The Installation Configuration screen settings will normally not need to be changed. All the defaults are set for a standard machine.

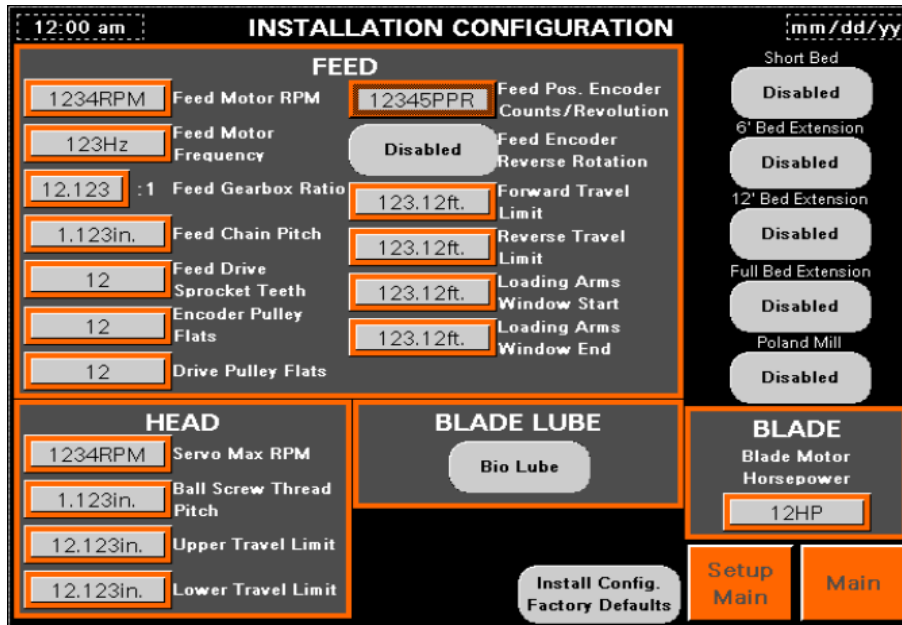

FIG. 3-40

1. **Feed Motor RPM** - Used to calculate the proper frequency for the variable frequency drive to achieve an accurate speed in ft/min or m/min.
2. **Feed Motor Frequency** - Used to calculate the proper frequency for the Variable Frequency Drive to achieve an accurate speed in ft/min or m/min.
3. **Feed Gearbox Ratio** - Used to calculate the proper frequency for the Variable Frequency Drive to achieve an accurate speed in ft/min or m/min.
4. **Feed Chain Pitch** - Used to calculate the feed position in feet or meters from the encoder rotations and used to calculate the proper frequency for the Variable Frequency Drive to achieve an accurate speed in ft/min or m/min.
5. **Feed Drive Sprocket Teeth** - Used to calculate the proper frequency for the Variable Frequency Drive to achieve an accurate speed in ft/min or m/min.
6. **Feed Pos. Encoder Counts/Revolution** - Used to calculate the feed position in feet or meters from the encoder rotations and the speed in ft/min or m/min that the head is feeding.
7. **Feed Encoder Reverse Rotation** - Changes the direction the feed encoder tracks if the encoder mounting location is changed and rotates in the opposite direction.
8. **Forward Travel Limit** - *The stop position for forward head travel.*
9. **Reverse Travel Limit** - *The stop position for reverse head travel.*
10. **Loading Arms Window Start** - *The starting position outside which the head must be set to operate the loading arms.*
11. **Loading Arms Window End** - *The ending position outside which the head must be set to operate the loading arms.*
12. **Servo Max RPM** - *The maximum allowable RPM the servo can run.*
13. **Ball Screw Thread Pitch** - Used for movement calculations when manually moving the head up and down.
14. **Upper Travel Limit** - The stop position for the upward head travel.
15. **Lower Travel Limit** - The stop position for the downward head travel.
16. **Short Bed** - Enables the feed travel to be 3' shorter than a standard bed.

17. 6' Bed Extension - Enables the forward travel limit for 6' bed extension.

18. Bio Lube - Toggles between the Bio-Lube system and pressure lube system.

19. 12' Bed Extension - Enables the forward travel limit for the 12' bed extension. Enable the 12' bed extension hydraulics on the Setup screen.

NOTE: Only the 12' bed extension is equipped with hydraulics.

20. Full Bed Extension - Enables the Feed Travel to be 21' 6" longer than it was on a standard bed.

NOTE: The full Bed Extension will have additional options available on top of those.

A Full Bed Extension can have a 3rd log clamp.

The operator must choose between the 2nd log clamp and 3rd log clamp on the Setworks screens; only one of those clamps is active at any one time.

21. Poland Mill - Enables all settings for the Poland Mill.

22. Install Config. Factory Defaults - Resets all the values on the screen to factory defaults.

23. Blade Motor Horsepower - Used to calculate the blade motor power (horsepower or kilowatts) from the soft-start feedback.

Feed Setup

The Feed Setup screen sets the Return To Start Of Log functions, and calibrates the feed position. You can also reference feed speed from this screen.

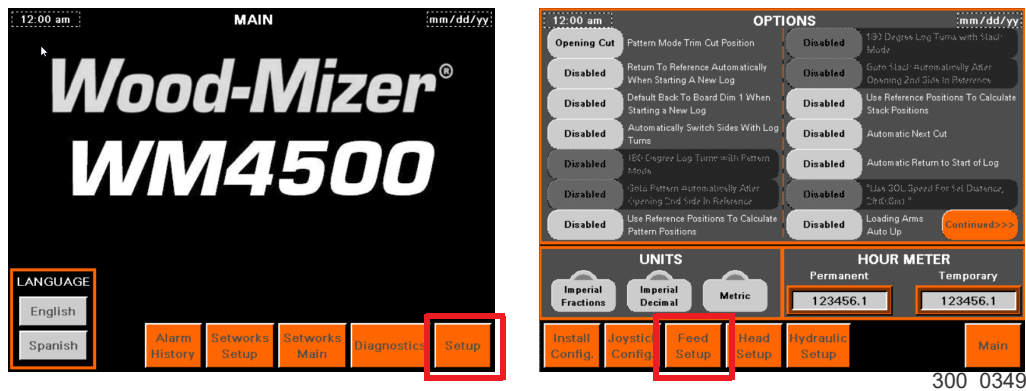

300_0349

FIG. 3-40

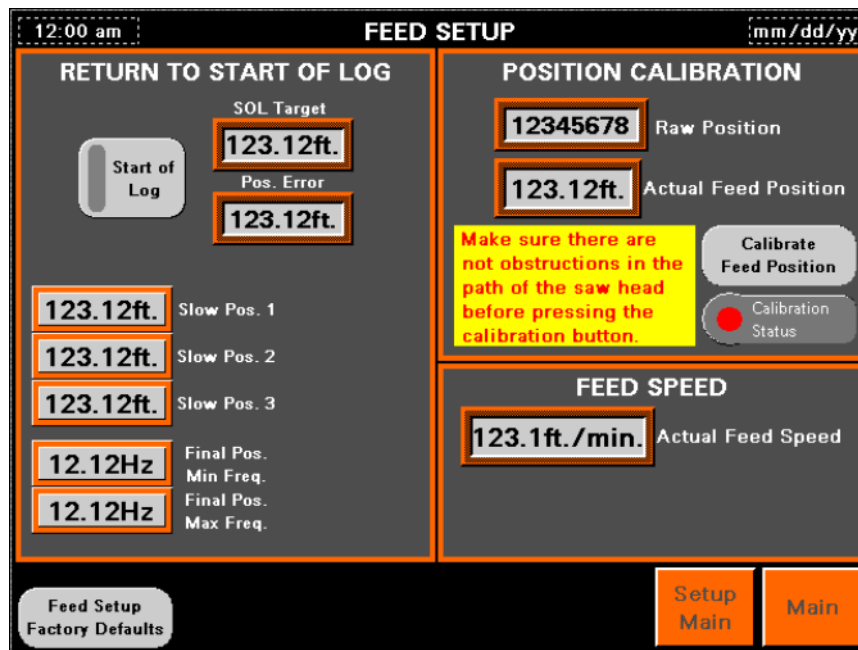

FIG. 3-41

POSITION CALIBRATION

The encoder tracks feed position at different locations (e.g. Start of Log Position and End of Log Position). These values facilitate automated functions during the sawing cycle.

The Raw Position displays the raw data from the encoder before it is converted to the actual units.

POSITION CALIBRATION PROCEDURE

NOTICE If the machine needs calibration, the HMI will automatically display the Feed Setup screen after control power is turned on. The only time this is not the first screen displayed after a power cycle is if there is a Joystick Configuration fault and the joysticks must be reset (therefore the joystick center and deadband must be set). Normally, this only happens during the initial install, and never again unless the PLC gets replaced.

NOTE: If the Feed Setup screen is already active then proceed to step 3.

1. From the Main screen press the Setup button. See Figure 3-40.
2. On the Setup screen press the Feed Setup button. See Figure 3-40.

NOTE: At the top right of the Feed Setup screen is the Position Calibration section. If the calibration is *required*, then the Calibration Status will be red; it indicates green for routine calibrations.

3. Ensure there are no obstructions in the path of the saw head to the reverse hard stop.
4. Press the **Calibrate Feed Position** button.

The head will start slowly traveling to the reverse hard stop. The head presses against the hard stop until there is a spike in motor current on the feed motor; this calibrates the feed position. At that point that position is called 1' 0", and the **Actual Feed Position** should have a value around 1.0ft. The value may display above this due to the feed drive releasing pressure as the stop pushes the head back away from it.

The **Calibration Status** will turn green when the process is complete.

Head Setup

The Head Setup screen tunes and calibrates the head position.

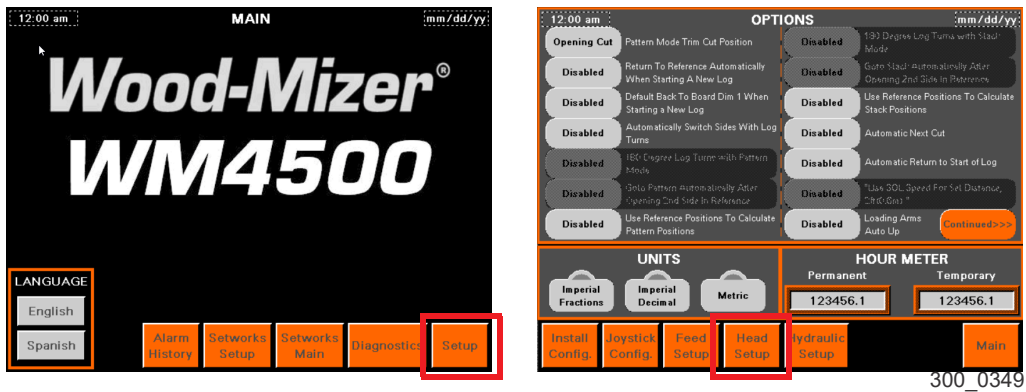

FIG. 3-41

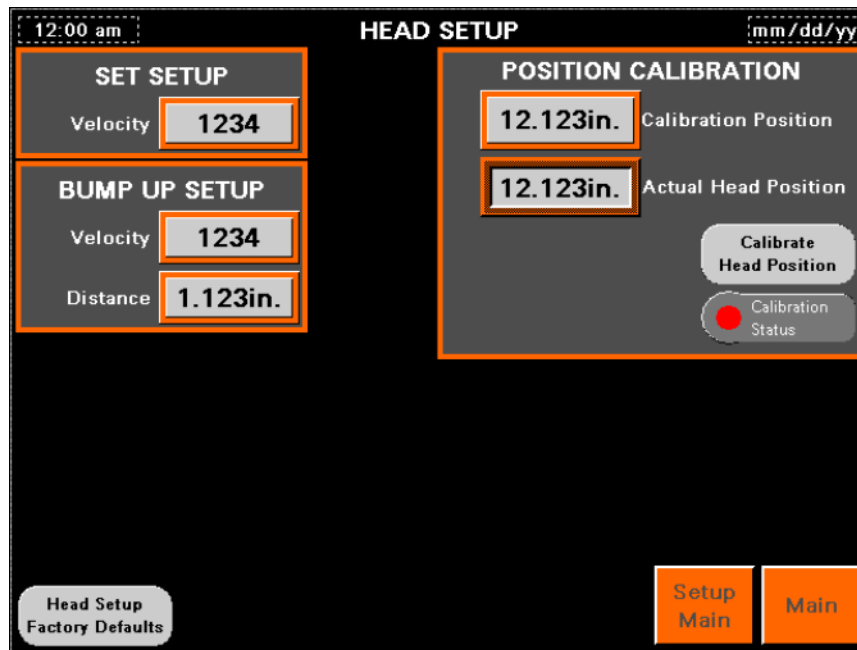

FIG. 3-42

POSITION CALIBRATION PROCEDURE

NOTICE If the machine needs calibrated, the HMI will automatically switch to the Head Setup screen after control power is turned on.

NOTE: If the Head Setup screen is already active then proceed to Step 3.

1. From the Main screen press the Setup button. (See Figure 3-41.)
2. On the Setup screen press the Head Setup button. (See Figure 3-41.)

At the top right of the Head Setup screen is the Position Calibration section. If the calibration is required then the Calibration Status will be red; it indicates green for routine calibrations.

3. Position the head over a bed rail and measure **from a down set tooth** to the bed rail.
4. Enter this value in the Calibration Position numeric entry box.
5. Press the Calibrate Head Position button.

Calibration complete.

Upper and Lower Saw Head Stop Adjustment

NOTICE Adjust the upper and lower head stop before operating the sawmill.

1. Remove the sawdust shield at the base of the mast. (See Figure 3-43.)
2. Loosen the jam nut at the lower stop bolt.
3. Set the saw head to move slowly to 1" above the sawmill bed; the saw head will stop automatically.
4. Adjust the lower head stop bolt to within 1/16-1/8" (1.5 - 3 mm) of the head frame.
5. Tighten the jam nut at the lower stop bolt..
6. Move the saw head slowly to 36" above the sawmill bed until the saw head automatically stops.
7. Loosen the jam nut at the upper stop bolt.
8. Adjust the upper head stop bolt to within 1/16-1/8" (1.5 - 3 mm) of the head frame.
9. Tighten the jam nut at the upper stop bolt.

10. Replace the sawdust guard.

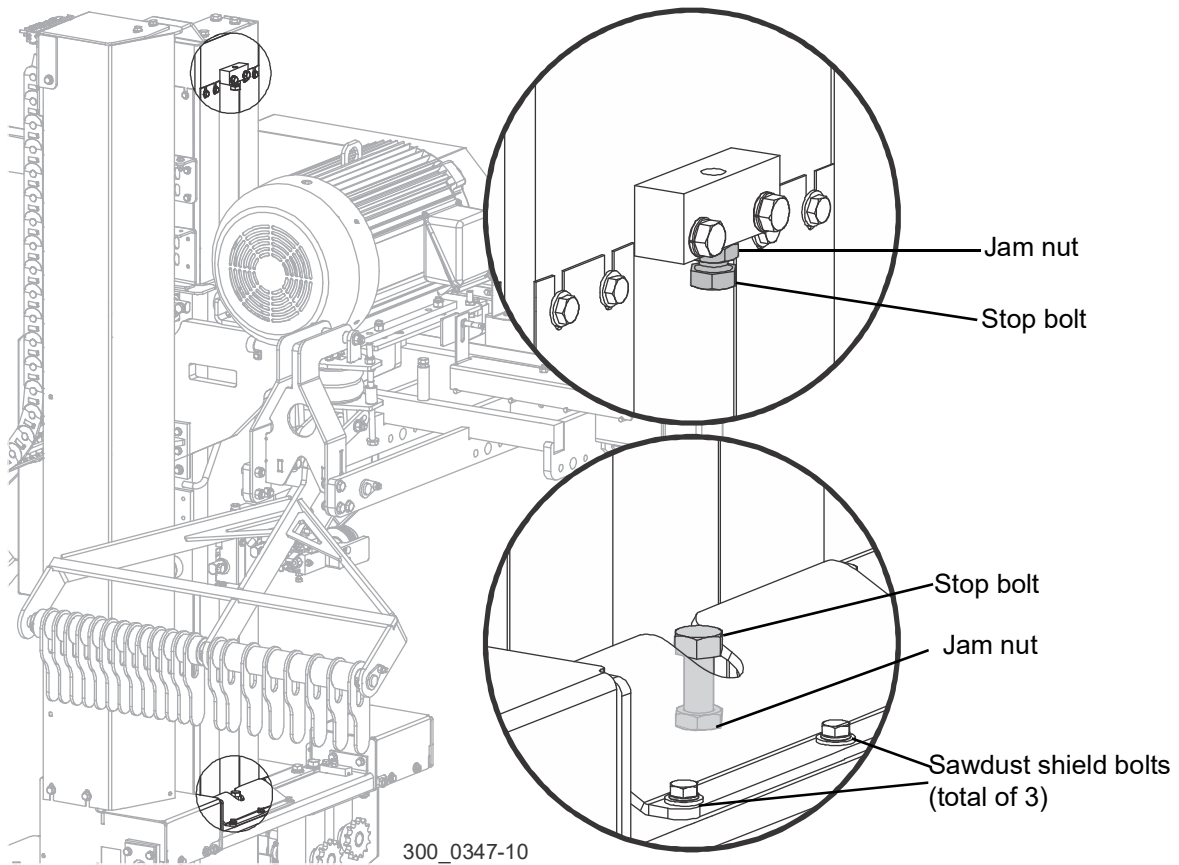

FIG. 3-43

NOTE: Check the upper and lower saw head stop settings every time the head position calibration is performed.

3 Setup

Networks Setup

Networks Setup

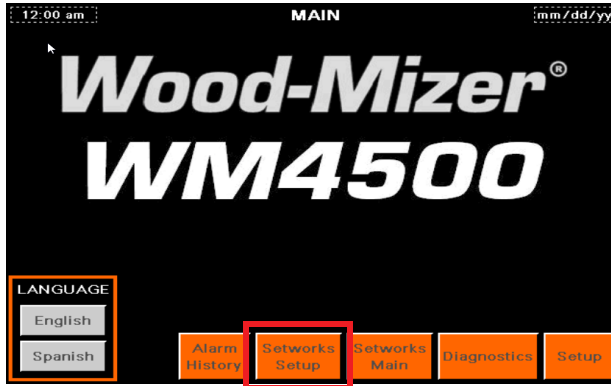
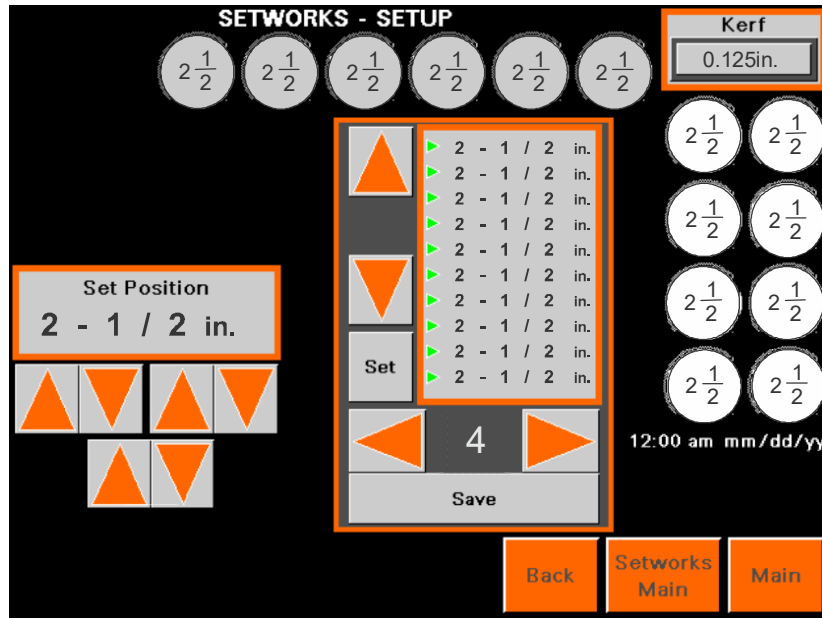

FIG. 3-43

There are six **Board Size** and eight **Cant Size** buttons used in Reference and Pattern modes. Their values are displayed on the touch screen when in these modes. T



300_0349-5

FIG. 3-44

There are four Stacks in Stack mode. Each stack has ten sizes.

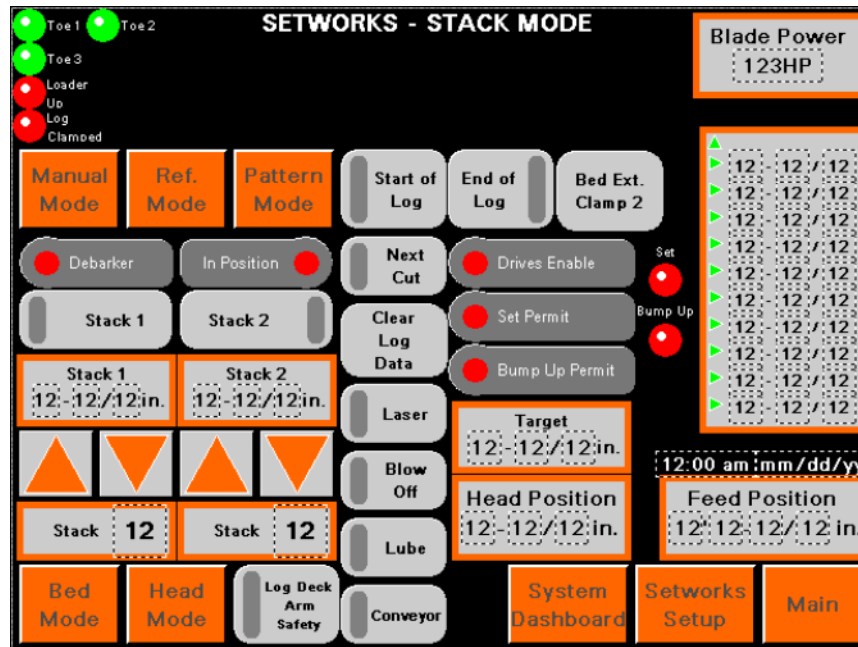

FIG. 3-45

To set the Kerf, Board Sizes, Cant Sizes, and Stack Sizes go to the Networks Setup screen.

From the Main, Reference, or Pattern screen press the Networks Setup screen.

To change board or cant sizes while cutting a log, use the buttons located in the mode you are in so that you do not leave networks and delete all your log date, i.e. Start of Log Position, End of Log Position, or Reference positions.

BOARD AND CANT SIZE SETUP (FRACTIONAL, DECIMAL, AND METRIC)

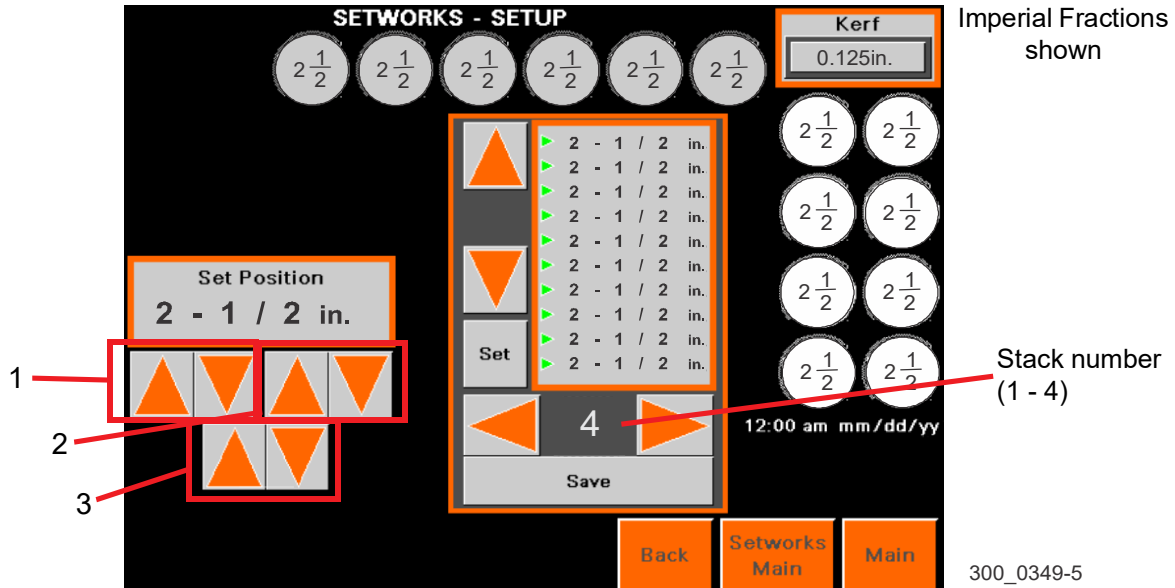

FIG. 3-46 IMPERIAL FRACTIONS SHOWN

BOARD SIZE. (6 circular gray buttons $2 \frac{1}{2}$) Sets the **board size** to the size selected.

SET POSITION. Shows the board size of the selected board. (Board size button highlights when selected.)

Increases or decreases the board size

- 1) by whole inches (Imperial) or 10mm (Metric).
- 2) by one thirty-second (0.0312) of an inch (Imperial) or 1mm (Metric).
- 3) by 0.1mm (Metric only).

KERF. Sets the blade kerf.

CANT SIZE. (8 circular white buttons $2 \frac{1}{2}$) Sets the **cant size** to the size selected.

SET. Selects the size to the position in the stack.

- Each size **above** the one set will be filled with the value entered.

(Stack Number) Assigns the stack to the position selected (1 through 4).

SAVE. Saves the full stack in memory.

SECTION 4 NETWORKS

4.1 Overview

The WM4500 operates in two main modes:

HEAD MODE. Accesses saw head functions (saw head up, down, forward, reverse, cruise control, board blow-off, and blade guide arm in or out). Toggle controls located

BED MODE. Accesses log handling functions (loader, clamp, turner, side supports, and rollers).

The mill must be in Head Mode to operate Setworks.

Setworks Operating Modes

MANUAL MODE. Operator-only controlled functions. Sets, bump ups, and return to start of log functions are disabled.

REFERENCE MODE. Operator-configured cut size based on the opening cut rather than an incremented distance from the bed.

In Reference Mode, the operator picks a reference point when opening the log, then each set after that will be the board size selected. The head does not directly reference from the bed but from the first cut, and will drop board sizes from there.

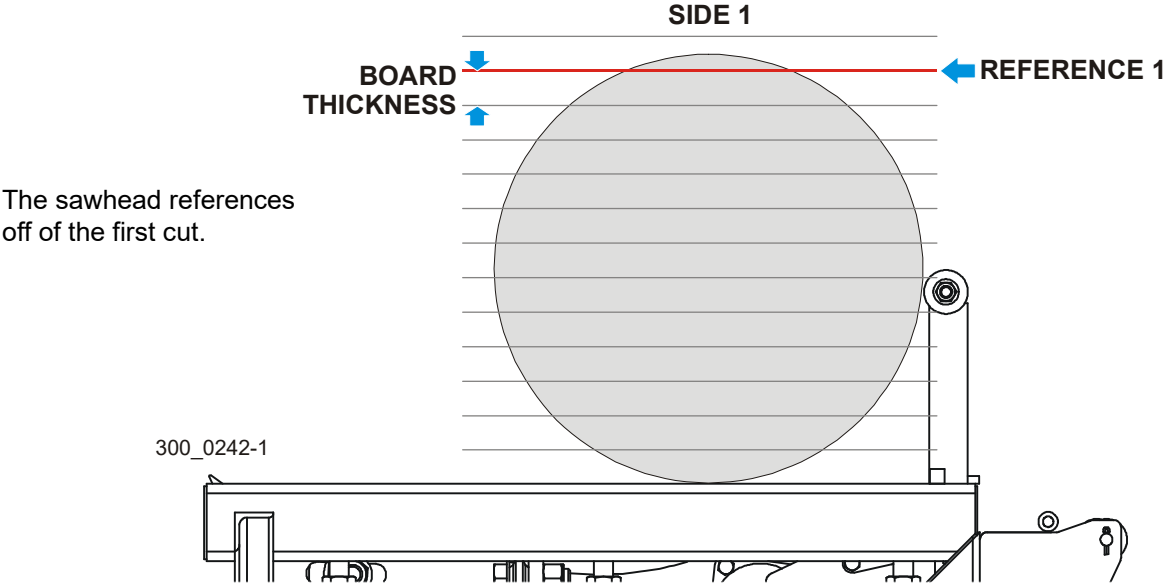

FIG. 4-1

PATTERN MODE. Operator places the head near where the opening cut is to be taken, then the software calculates where to make the first cut based off a pattern of the cant size

4 Networks

Networks Operating Modes

selected, number of cants, and the board size. These dimensions are referenced from the bed up.

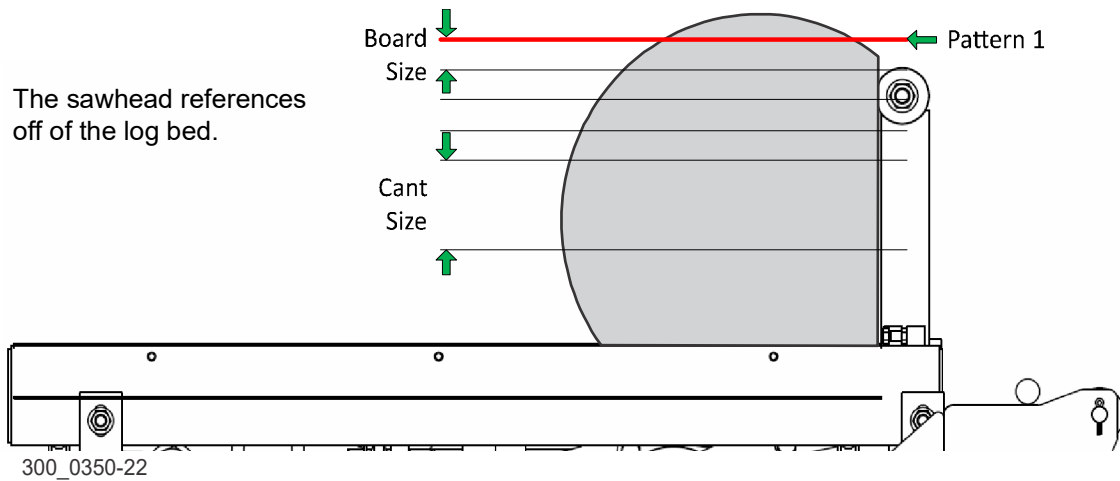

FIG. 4-2

STACK MODE. Operator selects a predefined stack memory, places the head near where the opening cut is to be taken, and presses the set button. After each cut, the head will drop to the next size in the stack memory. When above the stack all drops will be the size of the top stack size. These dimensions are directly referenced from the bed up.

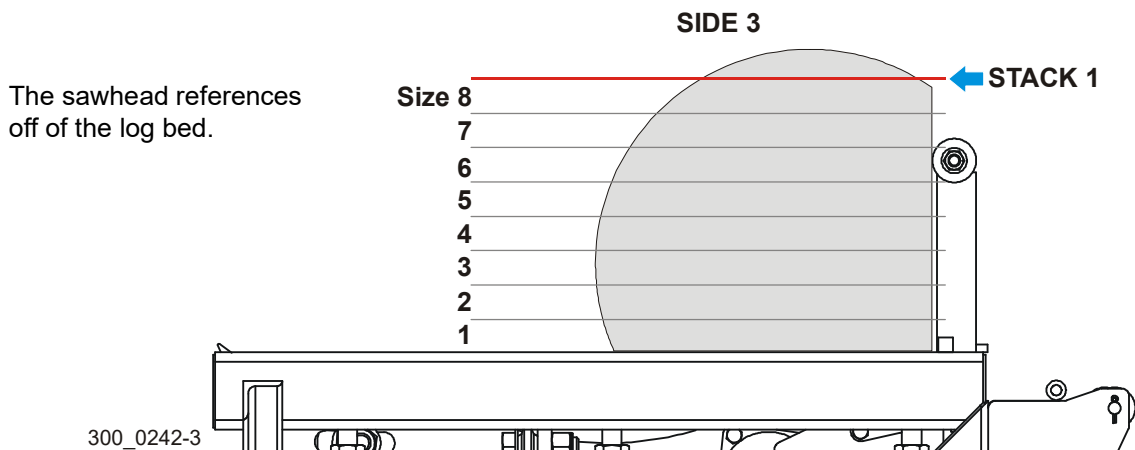

FIG. 4-3

4.2 Screen elements

INDICATORS: Indicators come in two styles.



INFORMATION DISPLAYS: Display only.



VALUE ENTRY BUTTONS: Changes/enters

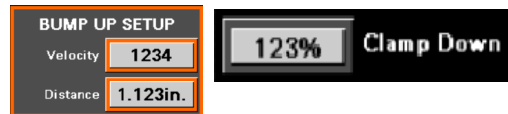

NOTE: Value displays appear recessed while value entry buttons appears raised.

FUNCTION BUTTONS: Modifies a function or inputs preset values. Buttons may have indicators to show when the function is active.



INCREASE/DECREASE BUTTONS: Used in various screens to increment settings or move between lines.



SCREEN CHANGE BUTTONS: Move to a different screen, often changing modes at the new screen.

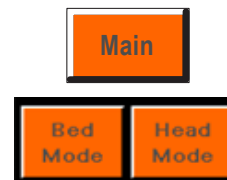

Exception: Head Mode and Bed Mode indicate the operation mode, and blink when the mode is active.

4 Networks

List of screens

NUMERIC ENTRY: Used in various applications. Indicates minimum and maximum value for function selected, if applicable.



300_0350-4

COMMON INDICATORS



300_0350-2

TOE 1, 2, OR 3. Green if the down output has been on for a preset time. Red if the last motion was up.

LOADER UP. Red while the loading arms are being lowered. Green while the arms are being raised, and stays green until lowered.

LOG CLAMPED. Red while log clamp is moving out. Green while log clamp is moving in and stays green until moved out.

NOTE: There may be a time delay between movement and indicator change

FIG. 4-4

4.3 List of screens

NOTE: All screen measurements are displayed in Imperial fraction mode.

[Main Screen](#)

[Setup-\(Options1\)](#)

[Setup \(Options2\)](#)

[Installation Configuration](#)

[Feed Setup](#)

[Networks - Setup](#)

[Networks - Manual](#)

[Networks - Reference Mode](#)

[Stack Mode](#)

[Dashboard](#)

[Head Setup](#)

[Hydraulic Function Speeds](#)

[Alarm History log](#)

[Diagnostics](#)

[See Section 4.5](#) for all diagnostics screens

[Joystick Configuration](#)

[Right Joystick Button Config. Head Mode](#)

[Left Joystick Button Config. Head Mode](#)

[Right Joystick Button Config. Bed Mode](#)

[Left Joystick Button Config. Bed Mode](#)

Main Screen

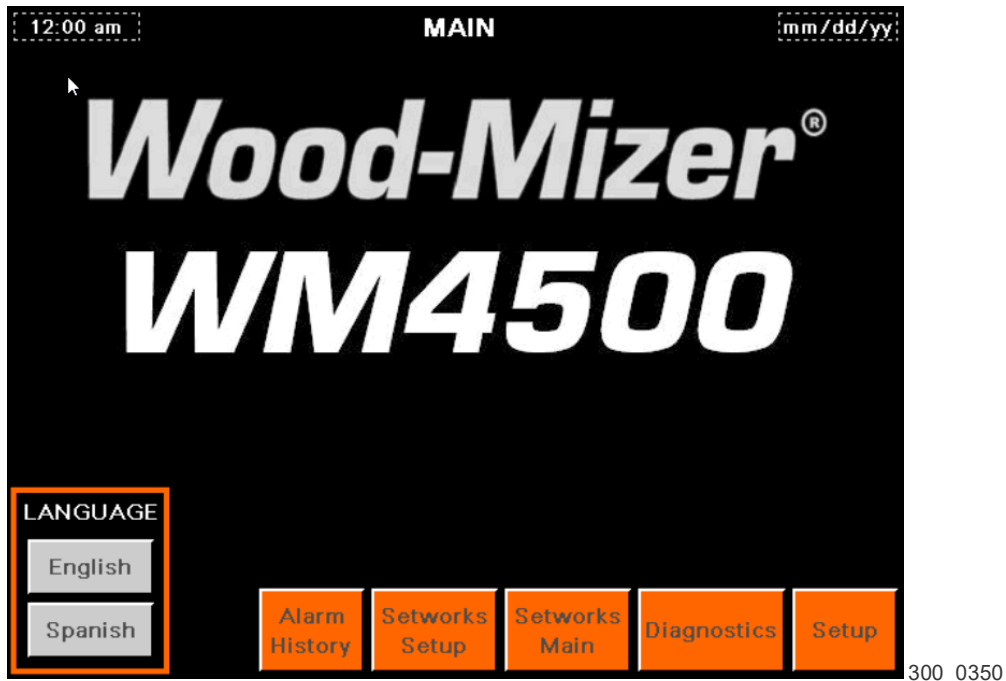

FIG. 4-5

LANGUAGE

Select English or Spanish

4 Networks

Alarm History log

BUTTONS

- **ALARM HISTORY.** Displays an [Alarm History log](#) screen.
- **NETWORKS SETUP.** Redirects to [Networks - Setup](#) screen.
- **NETWORKS MAIN.** Redirects to [Networks - Manual](#) screen.
- **DIAGNOSTICS.** Redirects to the [Diagnostics](#) screen.
- **SETUP.** Redirects to [Setup-\(Options1\)](#) screen

Alarm History log

Date	Time	State
m m / d d / y y	12:00:00am	x0000000x
%0%0%0%0%		
m m / d d / y y	12:00:00am	x0000000x
%0%0%0%0%		
m m / d d / y y	12:00:00am	x0000000x
%0%0%0%0%		
m m / d d / y y	12:00:00am	x0000000x
%0%0%0%0%		

300_0350-5

FIG. 4-6

Alarm History. displays the alarm codes which are used solely for diagnostic purposes.

Networks - Setup

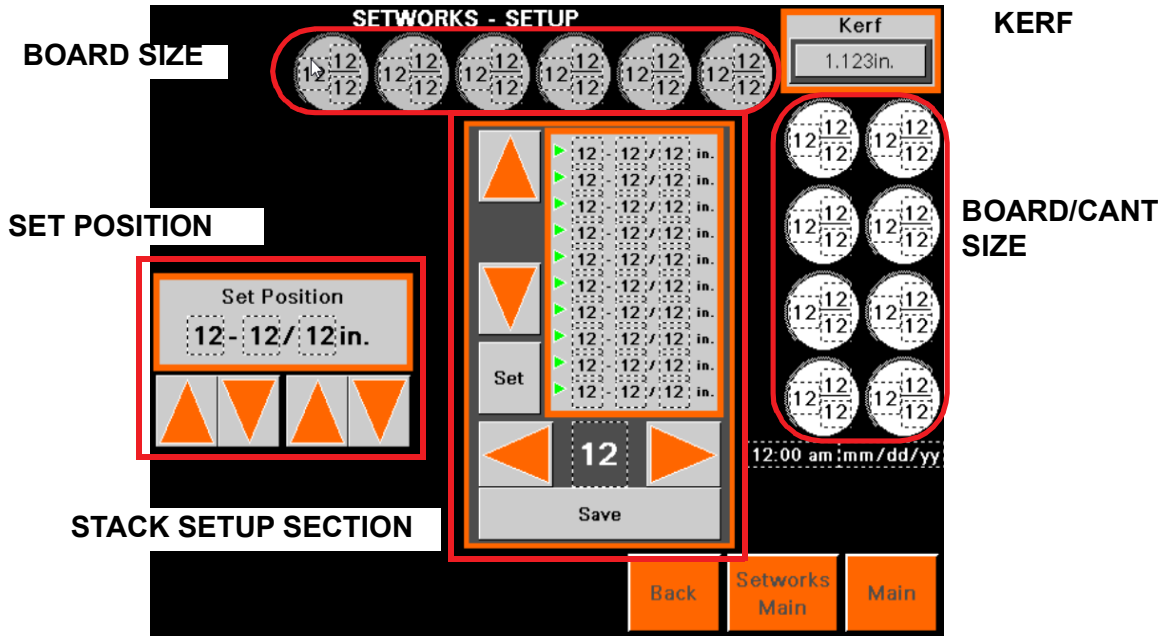

FIG. 4-7

There are six Board Size and eight Cant Size buttons used in Reference and Pattern-modes. Their values are displayed on the touch screen when in these modes.

BOARD SIZE. (6 circular gray buttons) Sets the **board size** to the size selected

SET POSITION. Shows the board size of the selected board. (Board size button highlights when selected.)

Increases or decreases the board size

- 1) by whole inches (Imperial) or 10mm (Metric).
- 2) by one thirty-second (0.0312) of an inch (Imperial) or 1mm (Metric).

KERF. Sets the blade kerf size.

BOARD/CANT SIZE. (8 circular white buttons) Sets the **cant size** to the size selected.

- In Reference mode, these are also considered board sizes
- In Pattern mode, these are only cant sizes

STACK SETUP SECTION. Selects the size to the position in the stack.

- Each size **above** the one set will be filled with the value entered.

(Stack Number) Assigns the stack to the position selected (1 through 4).

SAVE. Saves the full stack in memory.

Networks - Manual

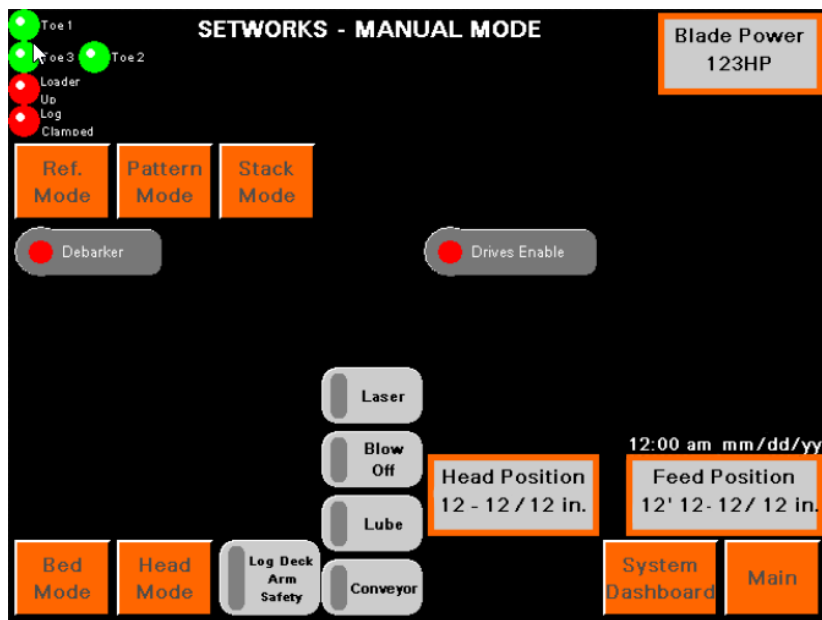

FIG. 4-8

DEBARKER. Turns green when the debarker is active, and red when off.

DRIVES ENABLE. Turns red when the feed or head drives are not enabled; green when enabled.

BLADE POWER. Displays the current blade motor power.

HEAD POSITION. Displays the current head position.

FEED POSITION. Displays the current feed position.

LASER. Turns the laser line on and off. Button indicator is green when the laser is on; gray when off.

BLOW OFF. Turns on the blow-off. Button indicator is green when the laser is on; gray when off.

NOTE: The blow-off valve is only active when the head is moving backwards.

LUBE. Turns the blade lube on. Button indicator is green when the laser is on; gray when off.

NOTE: The lube only works when the blade motor is running and the head is moving forward.

LOG DECK ARM SAFETY. Turns the log deck arm safety on.



CAUTION! Log deck arm safety prevents interference between the head and loading arms. When it is off the sawyer manually controls interference prevention.

CONVEYOR. Enables/disables the conveyor.

BED MODE. Activates Bed Mode. Button blinks when activated.

HEAD MODE. Activates Head Mode. Button blinks when activated.

Networks - Reference Mode

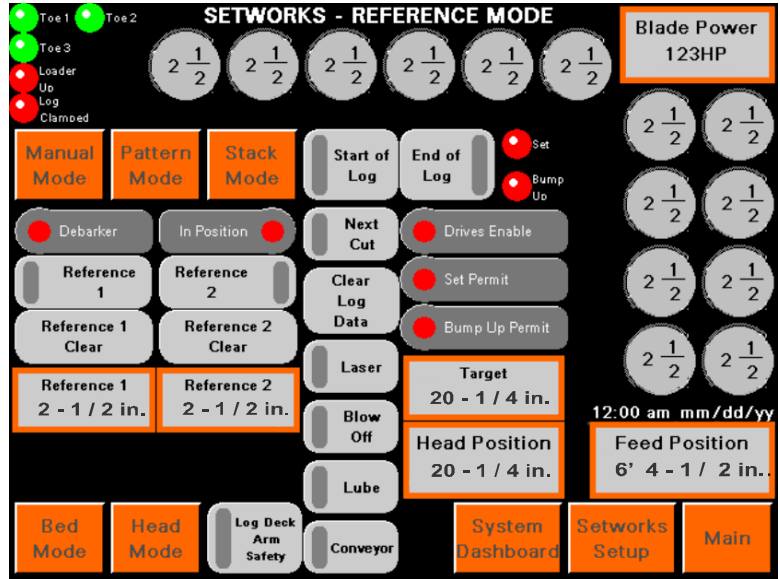

300_0349-4

FIG. 4-9

FUNCTION BUTTONS

- **BOARD SIZE-** Enters board size. Active board is highlighted. The active size circle will be highlighted.

NOTE: There are a total of 14 available board sizes in Reference Mode.
- **START OF LOG.** Sets the Start of Log position on the opening cut. The indicator turns green when set. (Also set by the joystick.)
- **END OF LOG.** Sets the End of Log position on opening cut. The indicator turns green when set. (Also set by the joystick.)
- **NEXT CUT.** Sets Next Cut setting to the next board size. The indicator turns green when set. (Also set by the joystick.)
- **CLEAR LOG DATA.** Clears all the data for Start of Log position, End of Log position, Reference 1, Reference 2, Pattern 1, and Pattern2.
- **LASER.** Turns the laser line on and off. Green for on; gray for off.
- **BLOW OFF.** Turns on the blow-off. Green for on; gray for off. The blow-off valve is only active when the head is moving backwards.

- **LUBE.** Turns the blade lube on. Green for on; gray for off. The lube only works when the blade motor is running and the head is moving forward.
- **LOG DECK ARM SAFETY.** Turns the log deck arm safety on and off.



CAUTION! Log Safety prevents interference between the head and loading arms. When it is off the sawyer is control of interference prevention.

- **CONVEYOR.** Enables/disables the conveyor.
- **REFERENCE 1/2.** Captures the current head position as Reference 1 or Reference 2.
- **REFERENCE 1/2 CLEAR.** Clears the values for Reference 1 or Reference 2.

INDICATORS

- **SET.** Green requesting a set function and will initiate when in a safe position to do so.
- **BUMP UP.** Green requesting a bump up function and will initiate when in a safe position to do so.
- **DEBARKER INDICATOR.** Turns green when the debarker is active, and red when it is not.
- **IN. POSITION INDICATOR.** Turns green when the head is in position, and red when it is not.
- **DRIVE ENABLED.** Turns green when the drive is enabled, and red when it is not.
- **SET PERMIT.** Blinks red when it is not safe to do a set; green for safe position (head must be behind the Start of Log position).
- **BUMP UP PERMIT.** Blinks red when it is not safe to do a bump up; green for safe position (head must be behind the Start of Log position).

INFORMATION

- **REFERENCE 1/2.** Displays the current position for reference one or two.
- **TARGET.** Displays the head position for a set or bump up. This allows you to compare the accuracy of the position when done, comparing it to the Head Position.

4 Networks

Networks - Pattern Mode

- **HEAD POSITION.** Displays the current head position
- **FEED POSITION.** Displays the current feed position

BED MODE. Activates Bed Mode. Button blinks when activated.

HEAD MODE. Activates Head Mode. Button blinks when activated.

Networks - Pattern Mode

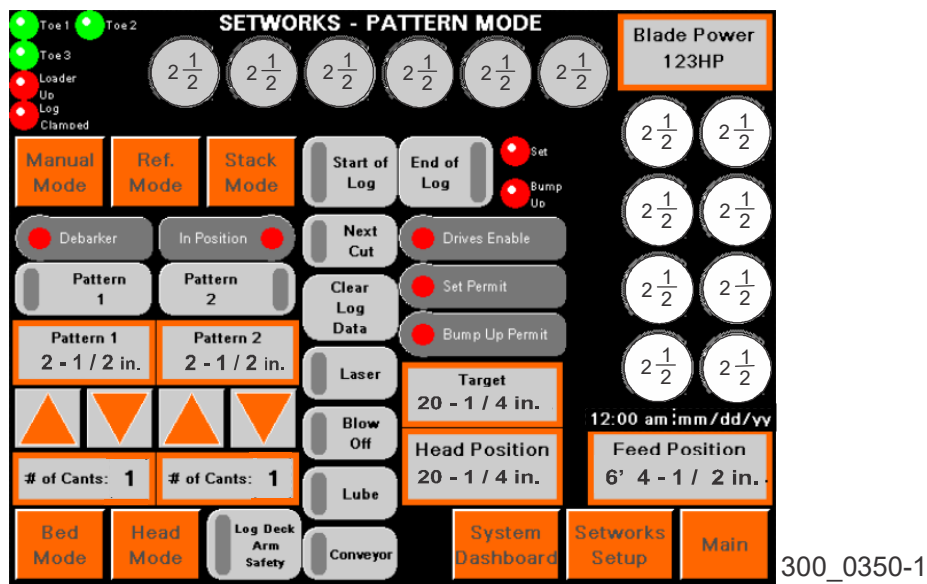

FIG. 4-10

See [Networks - Reference Mode](#) for the common functions. The operation of Pattern Mode screen is similar with the following exceptions:

BOARD/CANT SIZES. In Reference mode, these 8 right-hand size circles $2\frac{1}{2}$ are for

additional boards. In Pattern mode, these 8 sizes circles $2\frac{1}{2}$ are for cants. The active size circle is highlighted. In Reference mode there can only be one board size selected so if one of these is selected the previous 6 will all be inactive. In Pattern mode you select a cant size for each Pattern, 1 and 2, they can be different so that you can cut down to a 4x6, etc.

PATTERN 1 buttons and displays.

- **PATTERN 1**. Activates Pattern 1; turns green when the Pattern is active. Press and hold the button to clear out Pattern 1 position.
- **PATTERN 1**. Shows the current position of Pattern 1.
- **# OF CANTS**. This numeric display shows the number of cants in Pattern 1.

PATTERN 2 buttons and displays.

- **PATTERN 1**. Activates Pattern 2; turns green when the Pattern is active. Press and hold the button to clear out Pattern 2 position.
- **PATTERN 1**. Shows the current position of Pattern 2.
- **# OF CANTS**. This numeric display shows the number of cants in Pattern 1.

Stack Mode

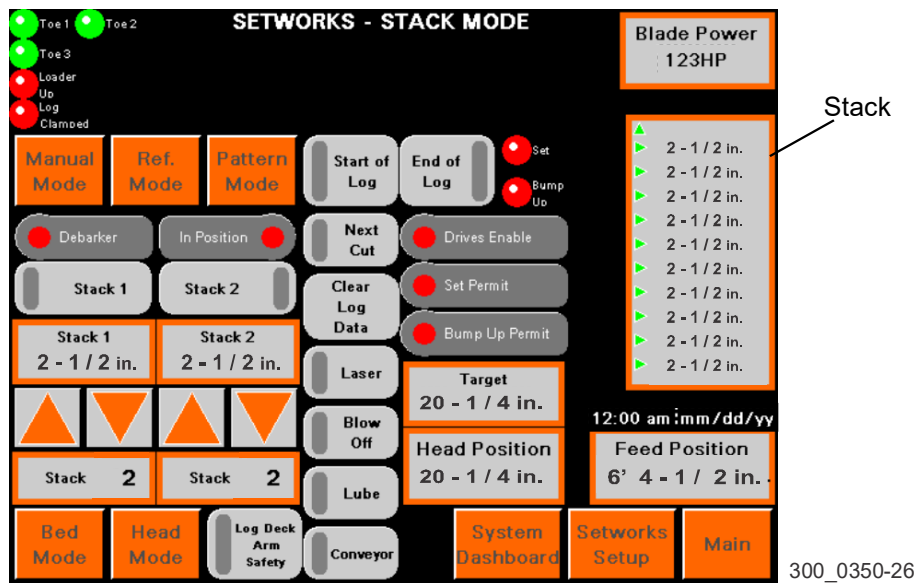

FIG. 4-11

See [Networks - Reference Mode](#) for the common functions. The operation of Pattern Mode screen is similar with the following exceptions:

STACK. Displays all the sizes in the stack and the current position you are at in the stack.

STACK 1 buttons and displays.

4 Networks Dashboard

- **STACK 1.** Activates Stack 1; turns green when the Stack is active. Press and hold to clear out Stack 1 position.
- **STACK 1.** Shows the current position of Stack 1.
- **STACK.** Shows the Stack memory selected.

STACK 2 buttons and displays.

- **STACK 2.** Activates Stack 1; turns green when the Stack is active. Press and hold to clear out Stack 1 position..
- **STACK 2.** Shows the current position of Stack 2.
- **STACK.** Shows the Stack memory selected.

Dashboard

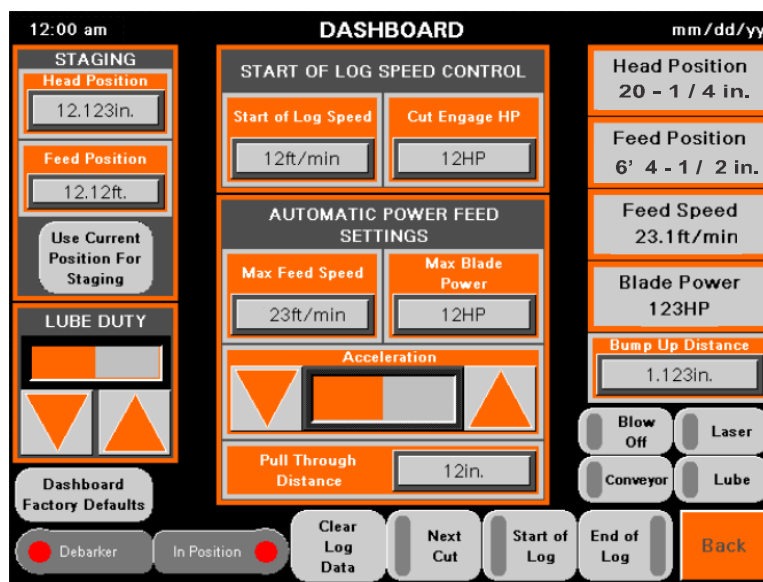

300_0350-27

FIG. 4-12

STAGING. Sets head return position.

1. Cut the last cut on the log.
2. Return saw head to start of log.

3. Press both the rear switch and bottom head button of the right joystick.

NOTE: These are for default joystick settings.

4. Release all joystick controls.

The head will return to the set feed position, then go to the set head position.

- **HEAD POSITION.** Press to enter the value you want and press enter.
- **FEED POSITION.** Press to enter the value you want and press enter.
- **USE CURRENT POSITION FOR STAGING.** Press to use current head position without entering a numeric value.

LUBE DUTY. Sets the lube pulses via increase/decrease buttons.

- **LUBE DUTY-GRAPH.** Shows the frequency of pulses of the lube system. The bar reads increasing pulses left to right.

DASHBOARD FACTORY DEFAULTS. Resets all values on the dashboard to factory defaults.

DEBARKER INDICATOR. Turns green when the debarker is active, and red when it is not.

IN. POSITION INDICATOR. Turns green when the head is in position, and red when it is not.

START OF LOG SPEED CONTROL. Controls the feed speed at the start of the log and the current threshold at which the machine assumes it is in an active cut based on blade motor power.

- **START OF LOG SPEED.** Press and enter the value you want then press enter.
- **CUT ENGAGE HP.** Press and enter the value you want then press enter.

AUTOMATIC POWER FEED SETTINGS. Controls automatic power feed reactions.

- **MAX FEED SPEED.** Shows the maximum feed speed the automatic feed will go to when trying to achieve the maximum blade power(10B). Press and enter the value you want then press enter.

- **MAX BLADE POWER.** Shows the maximum blade power the automatic feed will try to achieve. Press and enter the value you want then press enter.
- **ACCELERATION-GRAPH.** Shows feed rate acceleration when trying to reach the maximum blade power. Sets the acceleration via increase/decrease buttons. Bar reads increasing value left to right.

NOTE: Some woods will need lower acceleration for best cutting performance.

- **PULL THROUGH DISTANCE.** Shows the current distance the feed will move past the end of log position when in an automatic cut before returning to start of log.

For automatic cuts, ensure the pull-back fingers on the head drop before returning to start of log, or the head will jamb them against the log.

INDICATORS

- **HEAD POSITION.** Displays the current head position.
- **FEED POSITION.** Displays the current feed position.
- **FEED SPEED.** Displays the current feed speed.
- **BLADE POWER.** Displays the current blade motor power.

BUMP UP DISTANCE. Press and enter the value you want then press enter. Default is 0.625"(5/8").

BLOW OFF. Turns on the blow-off. Button indicator is green when the laser is on; gray when off.

NOTE: The blow-off valve is only active when the head is moving backwards.

COMMON BUTTONS

- **LASER.** Turns the laser line on/off.
- **CONVEYOR.** Enables/disables the conveyor.
- **LUBE.** Turns the blade lube on. Button indicator is green when the laser is on; gray when off.

NOTE: The lube only works when the blade motor is running and the head is moving forward.

- **CLEAR LOG DATA.** Clears all the data for Start of Log position, End of Log position, Reference 1, Reference 2, Pattern 1, and Pattern2.
- **NEXT CUT.** Sets Next Cut setting to the next board size. The indicator turns green when set. (Also set by the joystick.)
- **START OF LOG.** Sets the Start of Log position on the opening cut. The indicator turns green when set. (Also set by the joystick.)
- **END OF LOG.** Sets the End of Log position on opening cut. The indicator turns green when set. (Also set by the joystick.)

Setup-(Options1)

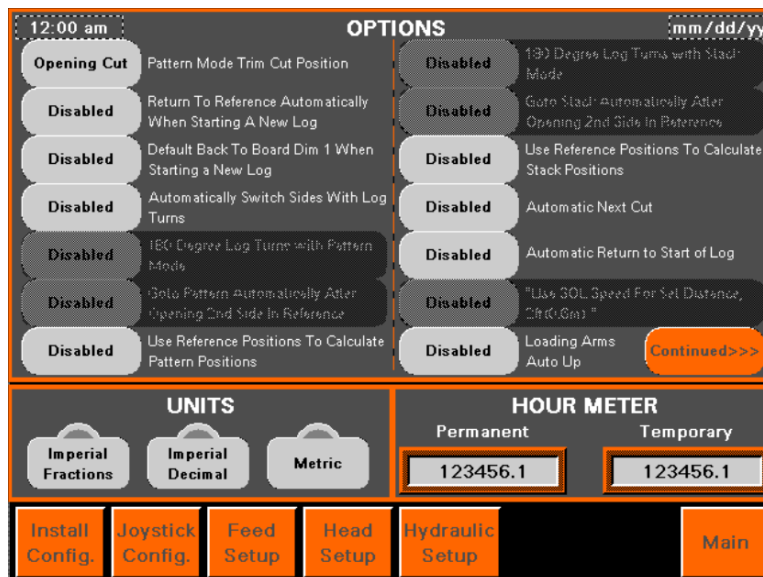

300_0350-14

FIG. 4-13

PATTERN MODE TRIM CUT POSITION. Selects the trim cut position; used either on the opening cut or before the first cant/last board.

RETURN TO REFERENCE AUTOMATICALLY WHEN STARTING A NEW LOG. Switches screen to Reference Mode at new log start.

DEFAULT BACK TO BOARD DIM 1 WHEN STARTING A NEW LOG. Selects the board sizes from the Reference Mode screen (read left to right) each time a new log is started.

AUTOMATICALLY SWITCH SIDES WITH LOG TURNS. When the log is unclamped and any chain turner functions is activated, Reference 1 or Reference 2 is activated. A cut must be taken on the new side before the Reference is switched again.

180 DEGREE LOG TURNS WITH PATTERN MODE. When the log is turned, the machine will assume the log is flipped 180 degrees and automatically goes to Pattern 1.

GO TO PATTERN AUTOMATICALLY AFTER OPENING 2ND SIDE IN REFERENCE. The Control switches to Pattern mode after a cut has been taken in Reference 2 and a log turn is sensed. *This option is not available unless the option to Automatically Switch Sides With Log Turns is enabled.*

USE REFERENCE POSITION TO CALCULATE PATTERN POSITIONS. When the trim cut position is set to **opening cut**, the last cut taken in Reference 1 will be used as the position to reference for the position of the head in Pattern mode for calculating the pattern based off the cant size selected, number of cants, and board size selected. This prevents having to search for best position for possible opening cut.

When the Trim Cut position is set to **first cant/last board**, the Last Cut taken in Reference 1 will be used as the last but taken in Pattern 1 and just set to the next board size. Reference 2 last cut position will be used for Pattern 2.

180 DEGREE LOG TURNS WITH STACK MODE. When the log is turned, a 180 degrees turn is expected, and sets to Stack 1.

GO TO STACK AUTOMATICALLY AFTER OPENING 2ND SIDE IN REFERENCE. Switches to Stack mode after a cut has been taken in Reference 2 and a log turn is sensed. *This option is not available unless the option to Automatically Switch Sides With Log Turns is enabled.*

USE REFERENCE POSITION TO CALCULATE STACK POSITIONS. The last cut taken in Reference 1 will be used as the position to reference for the position of the head in stack mode for calculating the starting position in the stack. Reference 2 last cut position will be used for Stack 2.

AUTOMATIC NEXT CUT. Turns on Next Cut when taking the opening cut on all four sides. A cut is sensed based on the blade motor power engage threshold setting.

AUTOMATIC RETURN TO START OF LOG. Return saw head to the position set for Start of Log. After the blade has exited the cut, bumped up, and started to move backwards, this function controls feed. Keep the joystick pressed and travel will stop automatically.

USE SOL SPEED FOR SET DISTANCE, 2FT (0.6M). The Start Of Log Speed set on the Dashboard screen will only be used for a distance of 2ft (0.6m) from the point where it

was set. Once the head has moved past this point, the speed is completely controller by the joystick.

LOADING ARM AUTO UP. Press and release the loader up button to move the loader up for a preset time period. When disabled it is necessary to hold the loader up button in order to raise the loader all the way.

CONTINUED. Use this button to go the second page of options.

Setup (Options2)

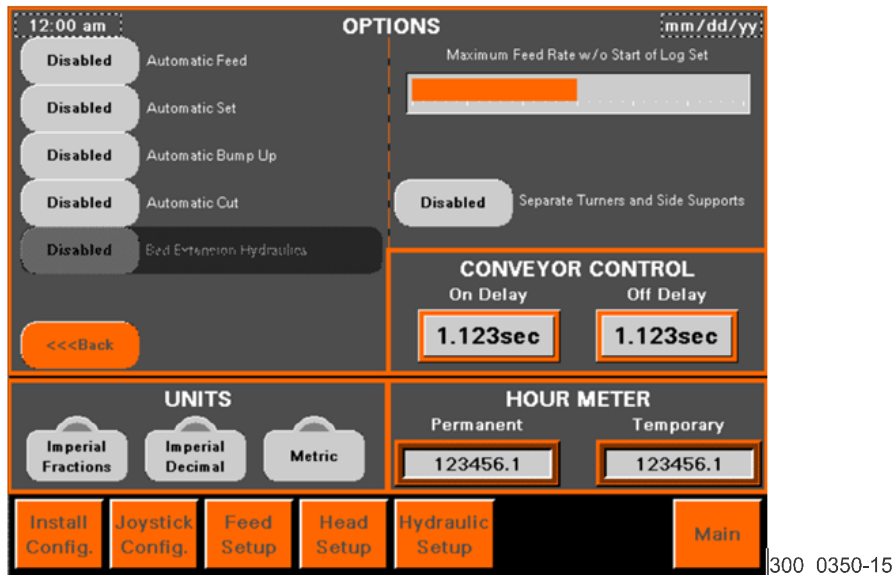

FIG. 4-14

AUTOMATIC FEED. Automatically controls the feed speed based on the, maximum speed and maximum power set on the Dashboard screen.

Feed rate will continue to increase until it reaches the maximum power setting or maximum speed setting is reached. The operator has control over the speed (joystick operation) up to the maximum preset speed.

AUTOMATIC SET. Sets to the Next Cut when the head has returned to the Start of Log position.

AUTOMATIC BUMP UP. Bumps up after the saw head has exited to cut and passed the End of Log position.

AUTOMATIC CUT. Runs the cutting process automatically when the operator holds down the foot pedal.

The operator must have the Start of Log and End of Log positions set, Next Cut on, then hold down the foot pedal when either at the Start of Log or End of Log positions. The head will automatically cut using the Automatic Feed, Bump Up, Return, and Set. This process continues until the foot pedal is released.

BED EXTENSION HYDRAULICS. Activates the hydraulics on the bed extensions and integrates them with the standard bed. This option is not available when the Bed Extension has not been turned on in the Installation Configuration.

MAXIMUM FEED RATE W/O START OF LOG SET. Sets the maximum forward feed rate when Start of Log is active allowing the head to move up to 300ft/min forward.

CONVEYOR CONTROL

- **ON DELAY.** Sets how long the feed must be in reverse before the conveyor will start.
- **OFF DELAY.** Sets how long the conveyor will keep running after the feed has stopped moving in reverse.

Installation Configuration

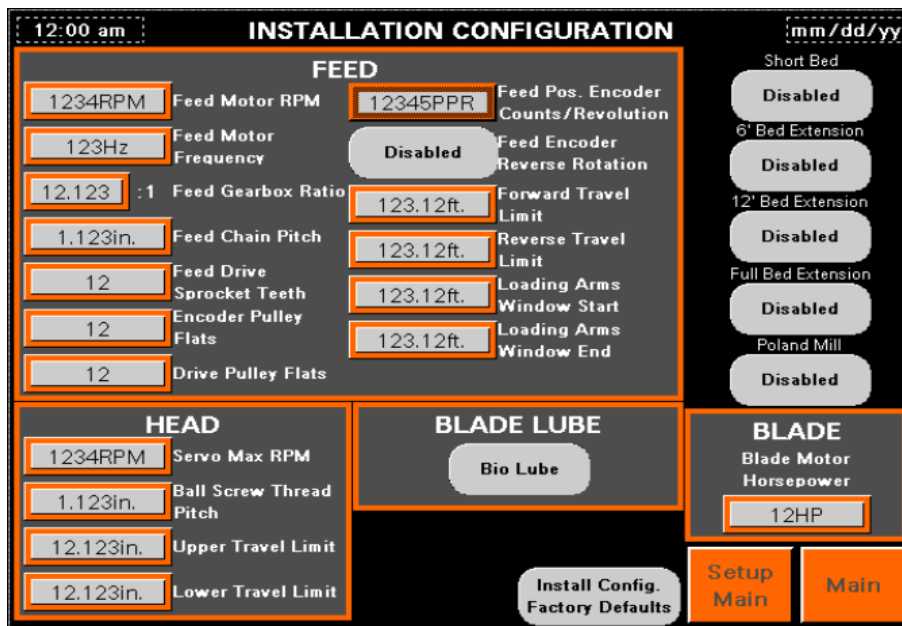

FIG. 4-15

These settings will normally not need changed. All the defaults are set for a standard machine.

1. **Feed Motor RPM** - Used to calculate the proper frequency for the variable frequency drive to achieve an accurate speed in ft/min or m/min.
2. **Feed Motor Frequency** - Used to calculate the proper frequency for the Variable Frequency Drive to achieve an accurate speed in ft/min or m/min.
3. **Feed Gearbox Ratio** - Used to calculate the proper frequency for the Variable Frequency Drive to achieve an accurate speed in ft/min or m/min.
4. **Feed Chain Pitch** - Used to calculate the feed position in feet or meters from the encoder rotations and used to calculate the proper frequency for the Variable Frequency Drive to achieve an accurate speed in ft/min or m/min.
5. **Feed Drive Sprocket Teeth** - Used to calculate the proper frequency for the Variable Frequency Drive to achieve an accurate speed in ft/min or m/min.
6. **Feed Pos. Encoder Counts/Revolution** - Used to calculate the feed position in feet or meters from the encoder rotations and the speed in ft/min or m/min that the head is feeding.

7. **Feed Encoder Reverse Rotation** - Disabled.
8. **Forward Travel Limit** - *The stop position for forward head travel.*
9. **Reverse Travel Limit** - *The stop position for reverse head travel.*
10. **Loading Arms Window Start** - *The starting position outside which the head must be set to operate the loading arms.*
11. **Loading Arms Window End** - *The ending position outside which the head must be set to operate the loading arms.*
12. **Servo Max RPM** - *The maximum allowable RPM the servo can run.*
13. **Ball Screw Thread Pitch** - Used for movement calculations when manually moving the head up and down.
14. **Upper Travel Limit** - The stop position for the upward head travel.
15. **Lower Travel Limit** - The stop position for the downward head travel.
16. **Short Bed** - Enables the feed travel to be 3' shorter than a standard bed.
17. **6' Bed Extension** - Enables the forward travel limit for 6' bed extension.
18. **12' Bed Extension** - Enables the forward travel limit for the 12' bed extension. Enable the 12' bed extension hydraulics on the Setup screen.

NOTE: Only the 12' bed extension is equipped with hydraulics.

19. **Full Bed Extension** - Enables the Feed Travel to be 21' 6" longer than it was on a standard bed.

NOTE: The full Bed Extension will have additional options available on top of those.

A Full Bed Extension can have a 3rd log clamp.

The operator must choose between the 2nd log clamp and 3rd log clamp on the Setworks screens; only one of those clamps is active at any one time.

20. **Poland Mill** - Enables all settings for the Poland Mill.
21. **Blade Lube** - Toggles between the Bio-Lube system and pressure lube system.

- 22. **Install Config. Factory Defaults** - Resets all the values on the screen to factory defaults.
- 23. **Blade Motor Horsepower** - Used to calculate the blade motor power (horsepower or kilowatts) from the soft-start feedback.

Feed Setup

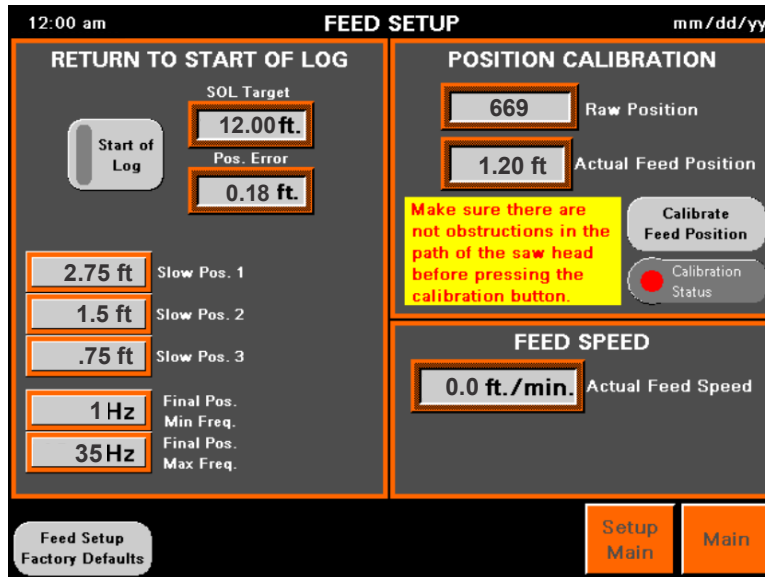

300_0349-2

FIG. 4-16

NOTICE If the Control needs calibration, the Feed Setup screen displays after control power is turned on. The only time this is not the first screen displayed after a power cycle is if there is a Joystick Configuration fault and the joysticks must be reset (therefore the furthest travel positions must be captured). Normally, this only happens during the initial install, and never again unless the PLC gets replaced.

RETURN TO START OF LOG

- **START OF LOG.** Moves the head into a safe position behind the log to perform a set
- **SOL TARGET.** The desired position for the feed system during the return.
- **POS. ERROR.** The difference between the actual Start of Log position and the Start of Log Target position.

During the return, after the head has passed the Start of Log Position, a Set will initiate. The feed will continue returning to the Target and then stop. Feed it forward, the head may stop at the Offset position, if the head is not in position for the next cut. If the head is in position, there will not be a stop, it will continue to feed forward and start the cut.

When tuning the Start of Log position try to get the smallest Pos. Error (usually within 2 inches) closest to the target position.

- **SLOW POS. 1** - Default = 2.75. The distance from Start of Log Target at which the feed drive will slow to 60Hz. Prior to reaching this point the feed will travel in reverse at maximum speed.
- **SLOW POS. 2** - Default = 1.5. The distance from Start of Log Target at which the feed drive will slow to the Final Pos. Max Freq.
- **SLOW POS. 3** - Default = 0.75. The distance from Start of Log Target at which the feed drive will ramp from the Final Pos. Max Freq., to the Final Pos. Min Freq.

The deceleration of the drive is proportional to the distance from Slow Pos. 3 to SOL Target. The drive will begin at the frequency in Final Pos. Max Freq. at Slow Pos. 3 and do a linear slope to the frequency in Final Pos. Min Freq. at SOL Target.

- **FINAL POS. MIN FREQ.** - Default = 1.
- **FINAL POS. MAX FREQ.** - Default = 35.

FEED SETUP FACTORY DEFAULTS. Returns setting on the Feed Setup screen to the factory default settings.

POSITION CALIBRATION

- **RAW POSITION.** Displays the raw data from the encoder before it is converted to the actual units.
- **ACTUAL FEED POSITION.** The position at which the head is pressing against a hard stop.
- **CALIBRATE FEED POSITION.** Initiates a calibration procedure.
- **CALIBRATION STATUS.** Displays red when a feed position calibration is required; displays green for routine calibration.

FEED SPEED

- **ACTUAL FEED SPEED.** Displays the actual feed speed.

Head Setup

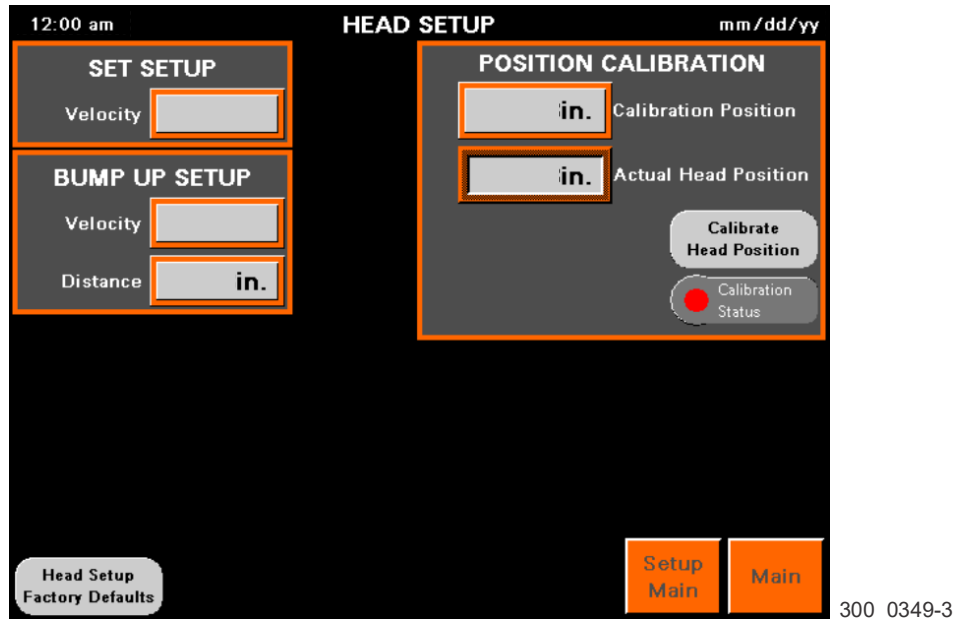

FIG. 4-17

The Head Setup screen set speed and calibrates the head position.

SET SETUP

- **VELOCITY:** Sets speed for sets.

BUMP UP SETUP

- **VELOCITY:** Sets speed for bump ups.
- **DISTANCE:** Sets distance for bump ups.

HEAD SETUP FACTORY DEFAULTS: Resets all the values back to factory defaults.

- **CALIBRATION POSITION:** Sets the position measured from a down set tooth to the bed rail and entered here.
- **ACTUAL HEAD POSITION:** Indicates head position.
- **CALIBRATE HEAD POSITION:** Runs calibration sequence.
- **CALIBRATION STATUS:** Red when calibration is necessary; green when good.

Hydraulic Function Speeds



FIG. 4-18

Select any hydraulic setting to change the values.

NOTE: Default is set to 100%. The only reason for changing the hydraulics settings is for troubleshooting.

Joystick Configuration

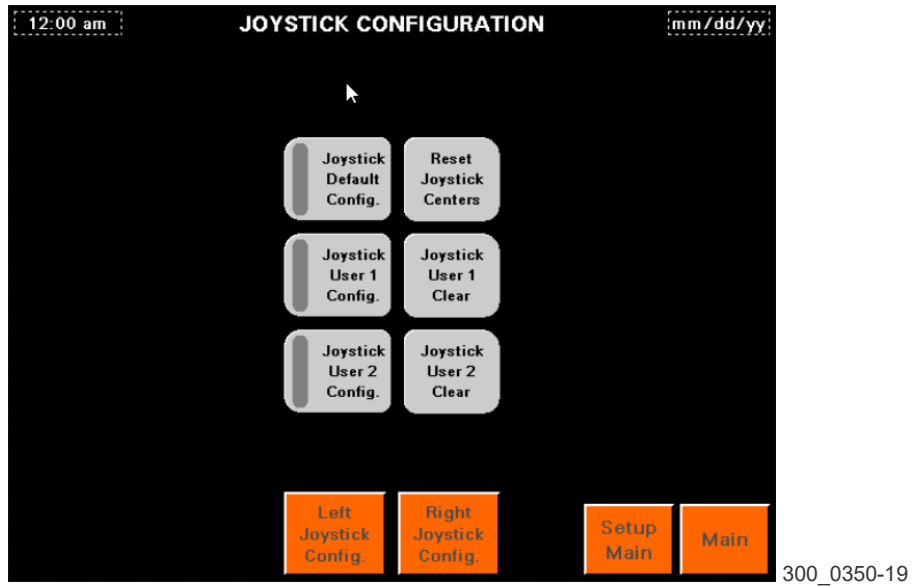

FIG. 4-19

The Joystick Configurations can be custom set for two users.

NOTICE All Joystick operations instructions are assuming that the Default settings are being used.

[See Section 3.5](#) for complete joystick information.

4 Networks

Right Joystick Button Config. Head Mode

Right Joystick Button Config. Head Mode

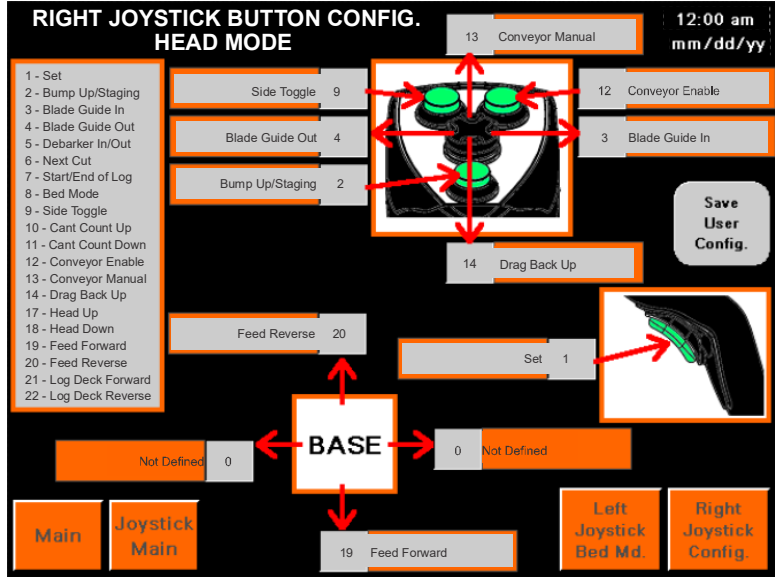

300_0350-20E

FIG. 4-20

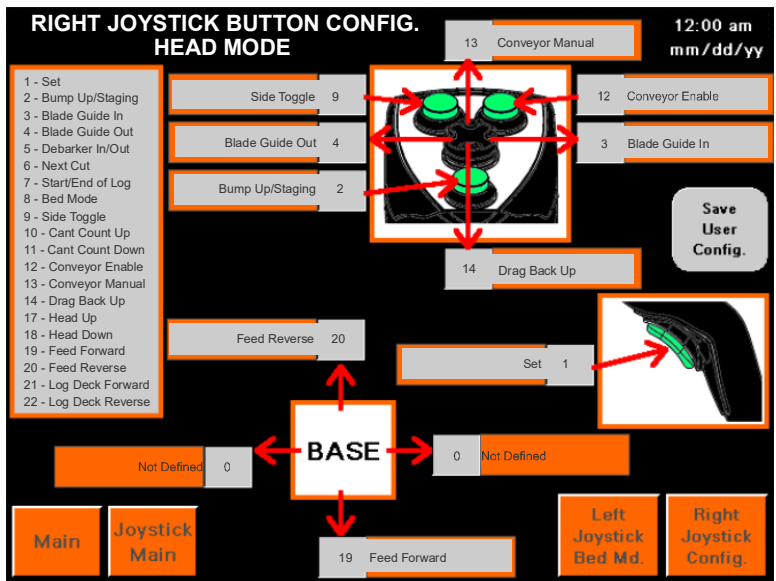

300_0350-20B

FIG. 4-21

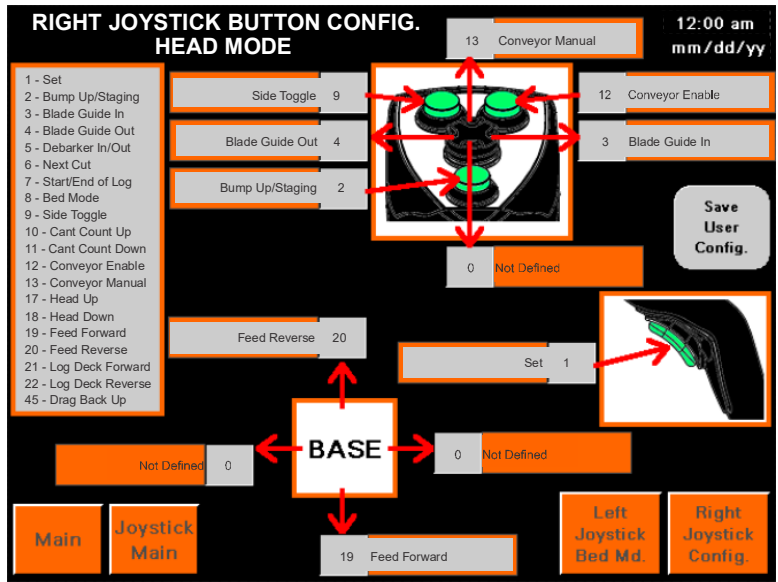

300_0350-20

FIG. 4-22

4 Networks

Left Joystick Button Config. Head Mode

Left Joystick Button Config. Head Mode

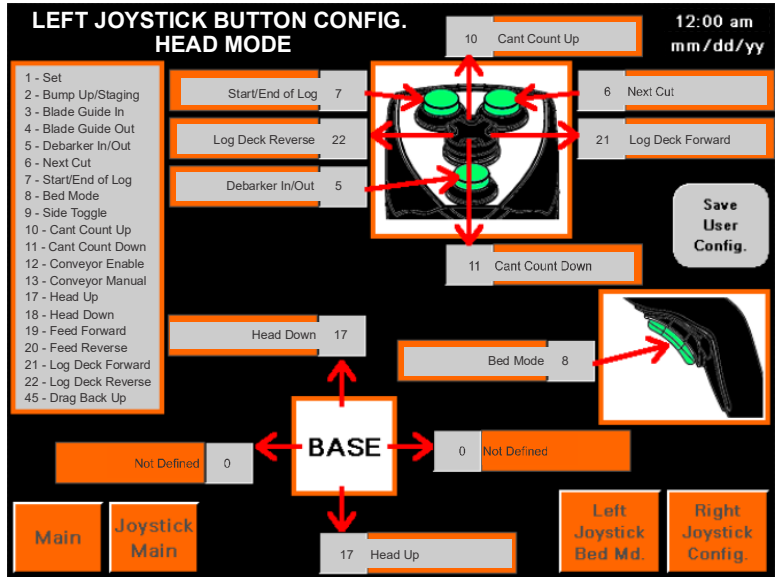

300_0350-25

FIG. 4-23

Right Joystick Button Config. Bed Mode

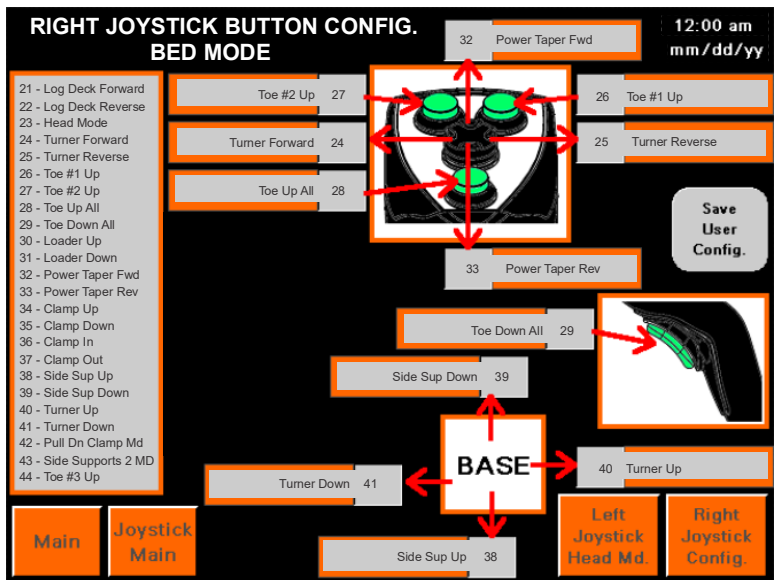

300_0350-24

FIG. 4-24

Left Joystick Button Config. Bed Mode

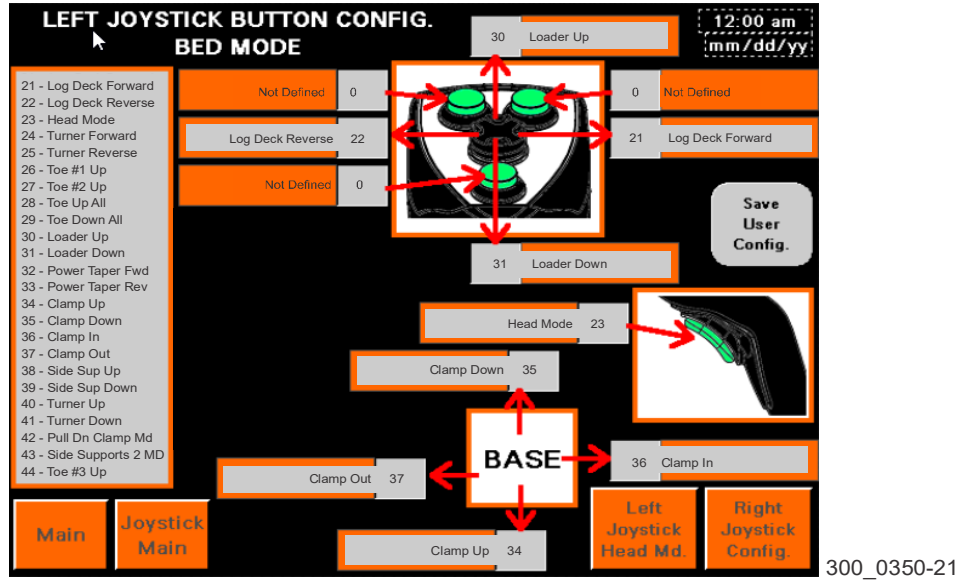

FIG. 4-25

4.4 Initial Sawmill Setup

NOTICE If you have not familiarized yourself with the Networks screens, please refer to [SECTION 4 Networks](#).

Installation Configuration

1. Release the emergency stop and push the control power-on green START button to activate the mill. ([See Section 6.5.](#))

NOTE: A pop-up window with a progress bar scrolling appears while communication is being established with the drive and it is being put into the operating state.

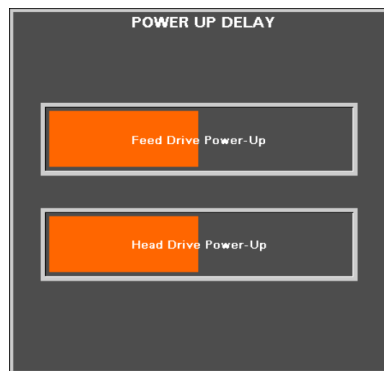

2. Press the **Setup** button on the Main Screen to enter the Setup (Options) screen.
3. Select the units of measure for your operation.

4. Press **Install Config.** to go to the next screen.

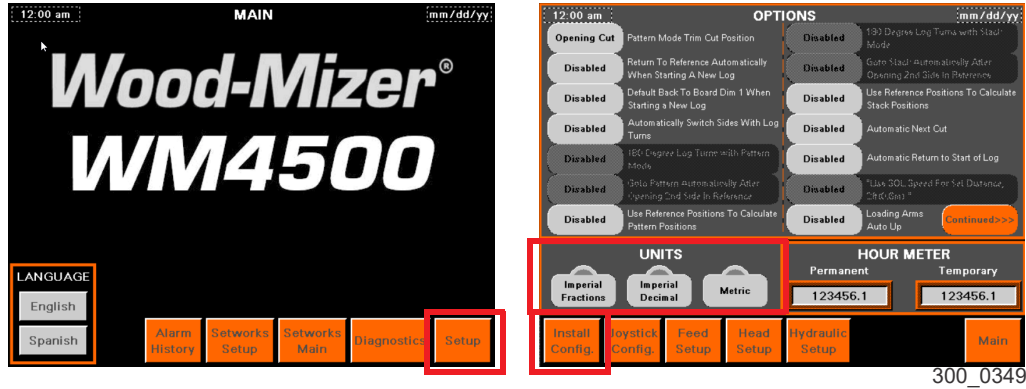

FIG. 4-25

Installation configuration

The Installation Configuration screen settings will normally not need to be changed. All the defaults are set for a standard machine.

NOTICE Fractional inches are displayed; decimal inches and metric measurements are also available under Units.

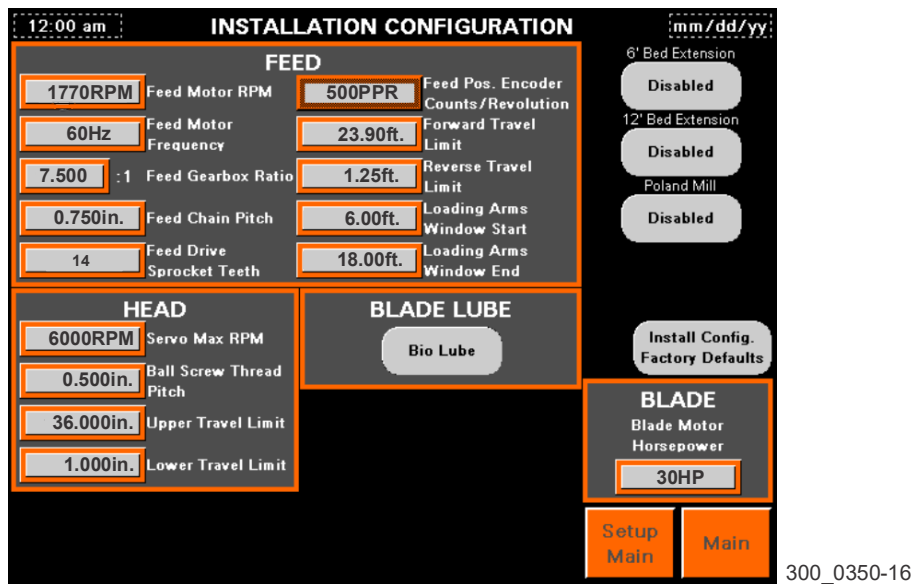

FIG. 4-26

Accept defaults. (See [Section 4.1 Overview](#) for detail information on settings.)

4 Networks Feed Calibration

Feed Calibration

The Feed Setup screen sets the Return To Start Of Log functions, and calibrates the feed position. You can also reference feed speed from this screen.

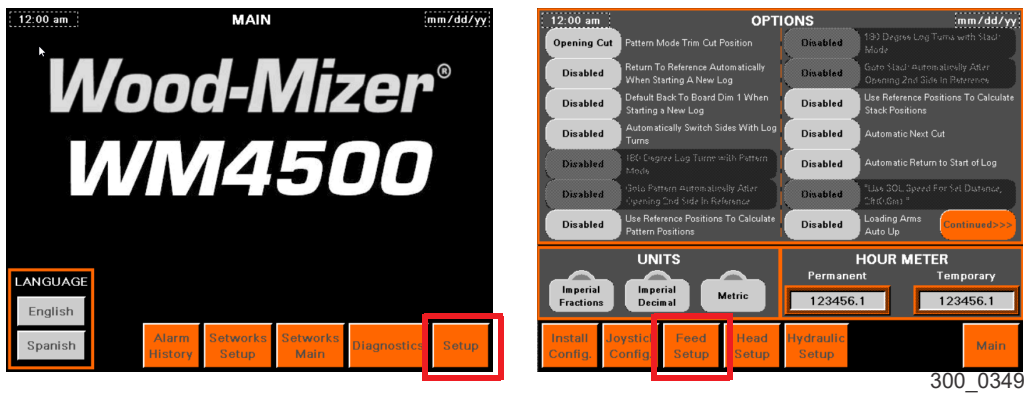

300_0349

FIG. 4-26

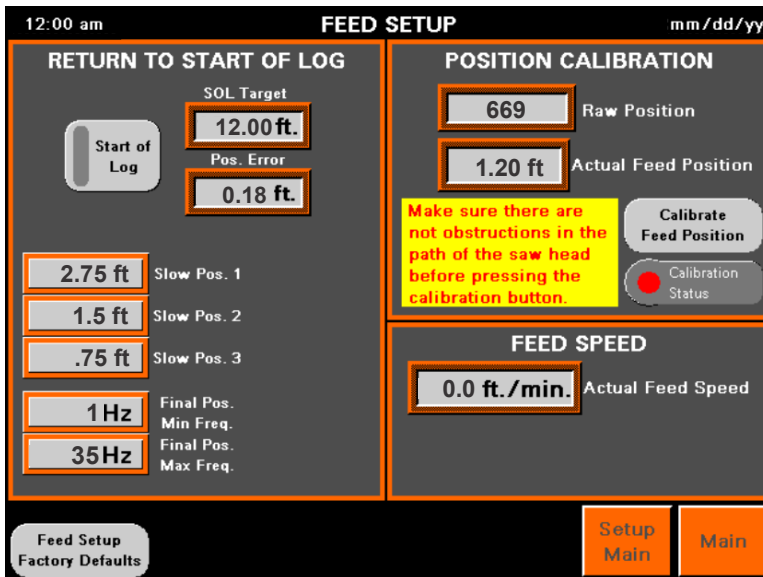

300_0349-2

FIG. 4-27

RETURN TO START OF LOG

The three positions for the Start of Log Position;

- Actual Start of Log Position is captured by pressing the button either on the touch screen or joystick. It signals the Control that the head has moved into a safe position behind the log and it is okay to perform a set
- Offset is the position the feed will stop at when feeding forward until it is in position for the next cut.
- Target is the position the feed system is shooting for during the return.

During the return, after the head has passed the Start of Log Position, a Set will initiate. The feed will continue returning to the Target and then stop. Feed it forward, the head may stop at the Offset position, if the head is not in position for the next cut. If the head is in position, there will not be a stop, it will continue to feed forward and start the cut.

TUNING RETURN TO START OF LOG

When tuning it you are trying to get the Pos. Error to be as small as possible so that you are as close as possible to the target you are trying to reach.

1. Move the head to set Start of Log and press the Start of Log button.

The indicator will turn green to show that the position has been set, and the position will display under SOL Target.

2. Run the feed about 12 ft. from that position.
3. Push the right joystick forward and maintain it until the head comes to a complete stop.
4. Check the Pos. Error.

If Pos. Error is within a 2 inches from the target, the tuning is finished. If the Pos. Error is larger than 2 inches, proceed to step 5.

5. Modify the Slow Positions and Final Pos. frequencies until you achieve the accuracy wanted.
 - Slow Pos. 1 - Default = 2.75. The distance from Start of Log Target at which the feed drive will slow to 60Hz. Prior to reaching this point the feed will travel in reverse at maximum speed.
 - Slow Pos. 2 - Default = 1.5. The distance from Start of Log Target at which the feed drive will slow to the Final Pos. Max Freq.
 - Slow Pos. 3 - Default = 0.75. The distance from Start of Log Target at which the feed drive will ramp from the Final Pos. Max Freq., to the Final Pos. Min Freq.

The deceleration of the drive is proportional to the distance from Slow Pos. 3 to SOL Target. The drive will begin at the frequency in Final Pos. Max Freq. at Slow Pos. 3 and do a linear slope to the frequency in Final Pos. Min Freq. at SOL Target.

- Final Pos. Min Freq. - Default = 1.
- Final Pos. Max Freq. - Default = 35.

POSITION CALIBRATION

The encoder tracks feed position at different locations (e.g. Start of Log Position and End of Log Position). These values facilitate automated functions during the sawing cycle.

The Raw Position displays the raw data from the encoder before it is converted to the actual units.

POSITION CALIBRATION PROCEDURE

NOTICE If the machine needs calibration, the Control will automatically display the Feed Setup screen after control power is turned on. The only time this is not the first screen displayed after a power cycle is if there is a Joystick Configuration fault and the joysticks must be reset (therefore the furthest travel positions must be captured). Normally, this only happens during the initial install, and never again unless the PLC gets replaced.

NOTE: If the Feed Setup screen is already active then proceed to step 3.

1. From the Main screen press the Setup button. See Figure 4-26.
2. On the Setup screen press the Feed Setup button. See Figure 4-26.

NOTE: At the top right of the Feed Setup screen is the Position Calibration section. If the calibration is *required*, then the Calibration Status will be red; it indicates green for routine calibrations.



CAUTION! Ensure there are no obstructions in the path of the saw head to the reverse hard stop.

3. Press the **Calibrate Feed Position** button.

The head will start slowly traveling to the reverse hard stop. The head presses against the hard stop until there is a spike in motor current on the feed motor; this calibrates the feed position. At that point that position is called 1' 0", and the **Actual Feed Position**

should have a value around 1.0ft. The value may display above this due to the feed drive releasing pressure as the rubber stop pushes the head back away from it.

The **Calibration Status** will turn green when the process is complete.

Head Calibration

The Head Setup screen tunes and calibrates the head position.

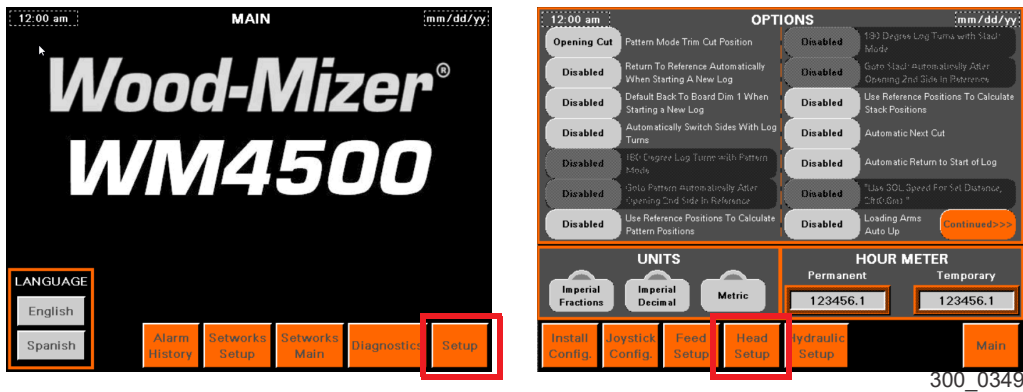

FIG. 4-27

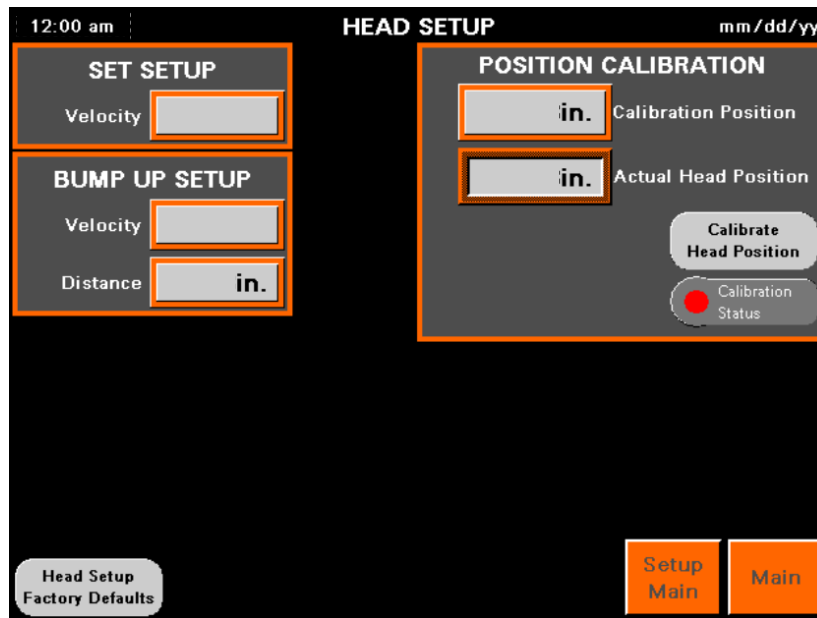

FIG. 4-28

POSITION CALIBRATION PROCEDURE

NOTICE If the machine needs calibrated, the Control will automatically switch to the Head Setup screen after control power is turned on.

NOTE: If the Head Setup screen is already active then proceed to Step 3.

1. From the Main screen press the Setup button. (See Figure 4-27.)
2. On the Setup screen press the Head Setup button. (See Figure 4-27.)

At the top right of the Head Setup screen is the Position Calibration section. If the calibration is required then the Calibration Status will be red; it indicates green for routine calibrations.

3. Position the head over a bed rail and measure **from a down set tooth** to the bed rail.
4. Enter this value in the Calibration Position numeric entry box.
5. Press the Calibrate Head Position button.

Calibration complete.

Upper and Lower Saw Head Stop Adjustment

NOTICE Adjust the upper and lower head stop before operating the sawmill.

1. Remove the sawdust shield at the base of the mast. (See Figure 4-29.)
2. Loosen the jam nut at the lower stop bolt.
3. Set the saw head to move slowly to 1" above the sawmill bed; the saw head will stop automatically.
4. Adjust the lower head stop bolt to within 1/16-1/8" (1.5 - 3 mm) of the head frame.
5. Tighten the jam nut at the lower stop bolt.
6. Move the saw head slowly to 36" above the sawmill bed until the saw head automatically stops.
7. Loosen the jam nut at the upper stop bolt.

8. Adjust the upper head stop bolt to within $1/16$ - $1/8$ " (1.5 - 3 mm) of the head frame.
9. Tighten the jam nut at the upper stop bolt.
10. Replace the sawdust guard.

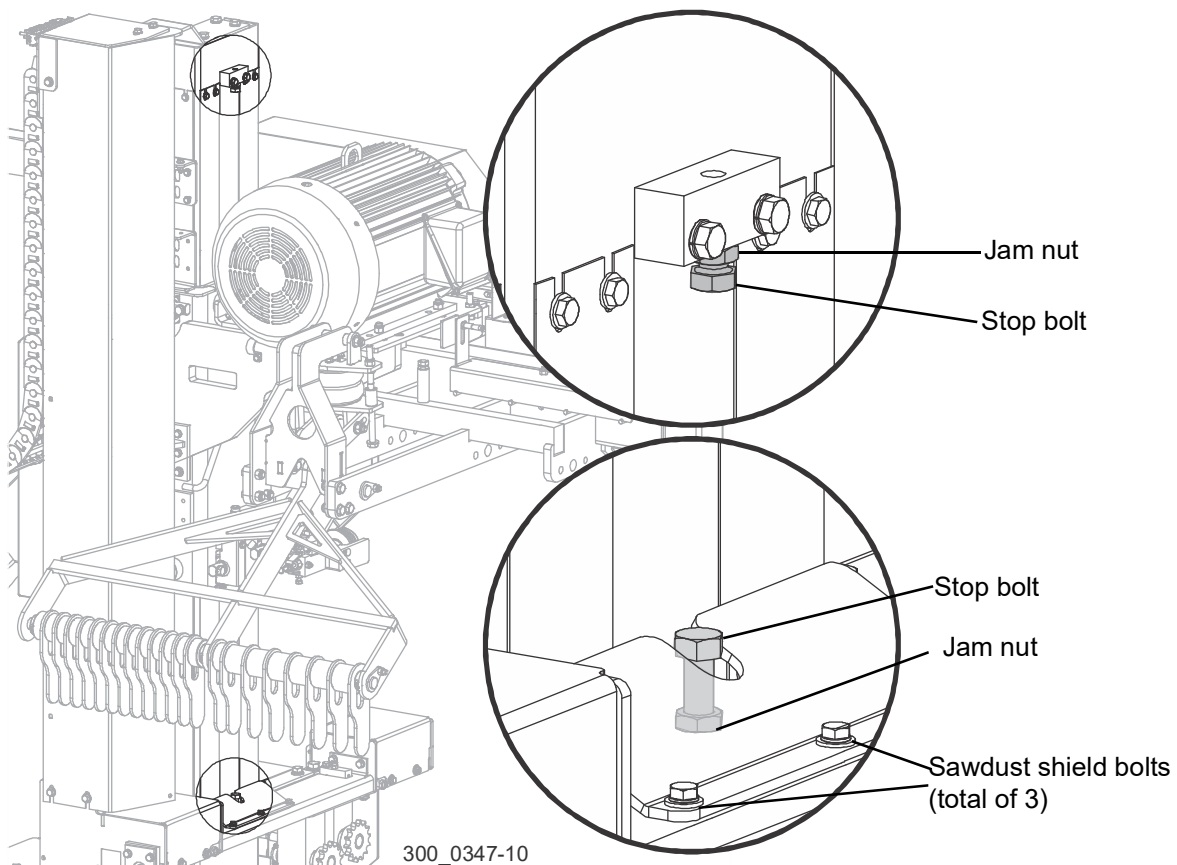

FIG. 4-29

NOTE: Check the upper and lower saw head stop settings every time the head position calibration is performed.

4 Networks

Networks Board/Cant Size Setup

Networks Board/Cant Size Setup

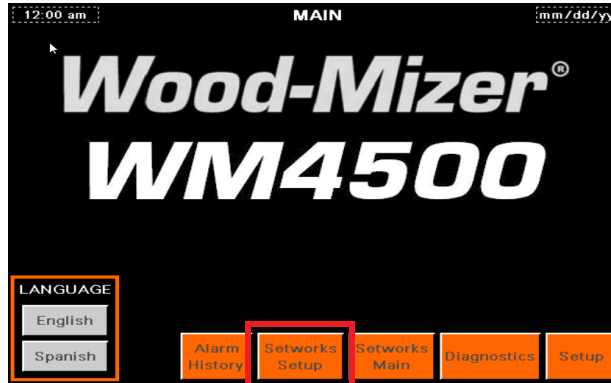

FIG. 4-29

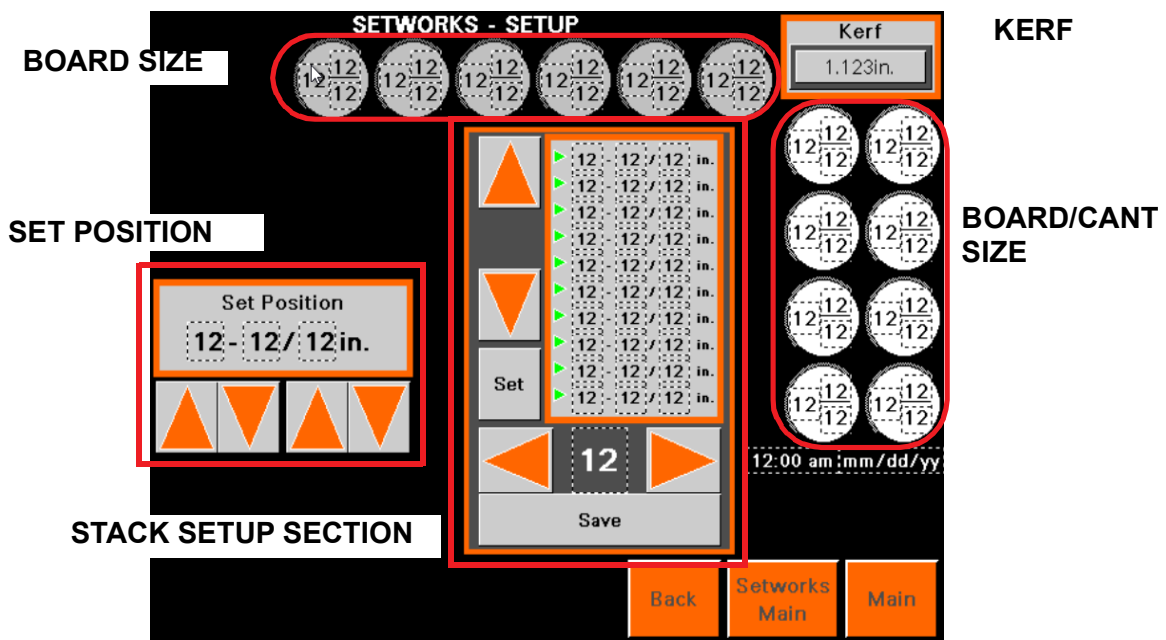

FIG. 4-30

See [Networks - Setup](#) for screen details.

1. Set the Kerf
 - a. Tap the Kerf button

b. Enter the kerf size to the thousandth of an inch and press enter on the numeric keypad.

2. Set a Board/Cant Size.

a. Adjust the Set Position to the desired size. See Fig. [FIG. 4-30](#).

The left set of up/down buttons adjust up and down by whole inches.
 The right set of up/down buttons adjust up and down by 1/32 inch.

b. Press a size button in Board Size or Board/Cant size section above to place that value on the board/cant size.

NOTE: Remember, both Board Size (gray buttons) and Board/Cant Size (white buttons) can be boards sizes in Reference Mode, but **only** Board/Cant Size (white buttons) is used for cants in Pattern Mode.

3. Set up a Stack..

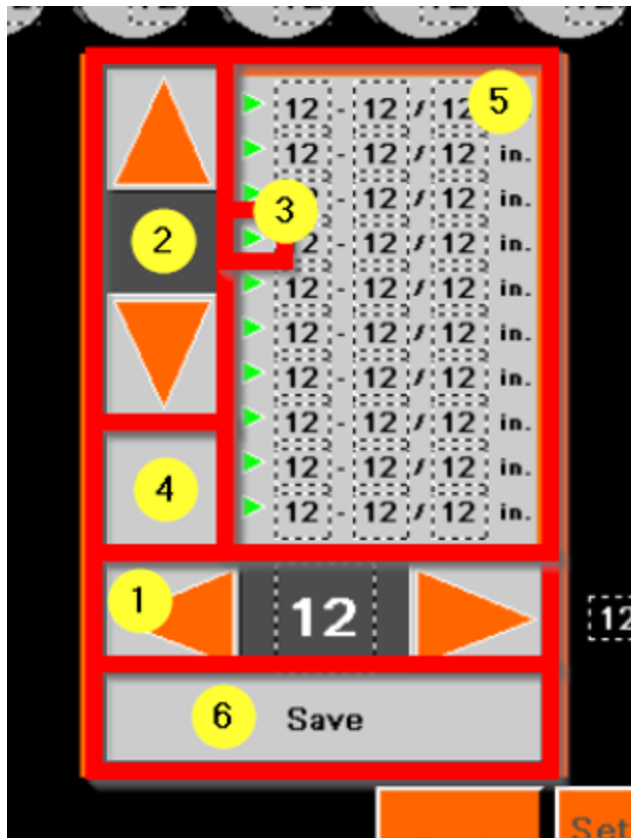

FIG. 4-31

Refer to Fig. 4-31 for the steps below:

- a. Use the left and right arrows in section 1 to select which stack to setup. (A total of 4 stacks may be set up.)
- b. Use the up and down arrows in section 2 to select which position of the stack to edit in the stack (section 5).

The size being edited will be highlighted by a green arrow, 3, in the image above.

Start from the bottom.

NOTE: Each time you set a size, all the sizes above that take on that same size.

- c. Use the Set Position buttons to set the desired size. Reference Fig. 4-30.
 - d. Press the Set button (section 4) to place it in the stack and fill all the sizes above that point.
 - e. Use the up and down arrows to move up the stack and edit values as desired.
4. When finished press the Save button, section 6, and setup another stack, if desired.

NOTICE To change board or cant sizes while cutting a log, you must use the buttons located in the mode (Reference, Pattern or Stack) you

are in. **Leaving Networks deletes all your log data** (Start of Log Position, End of Log Position, or Reference positions).

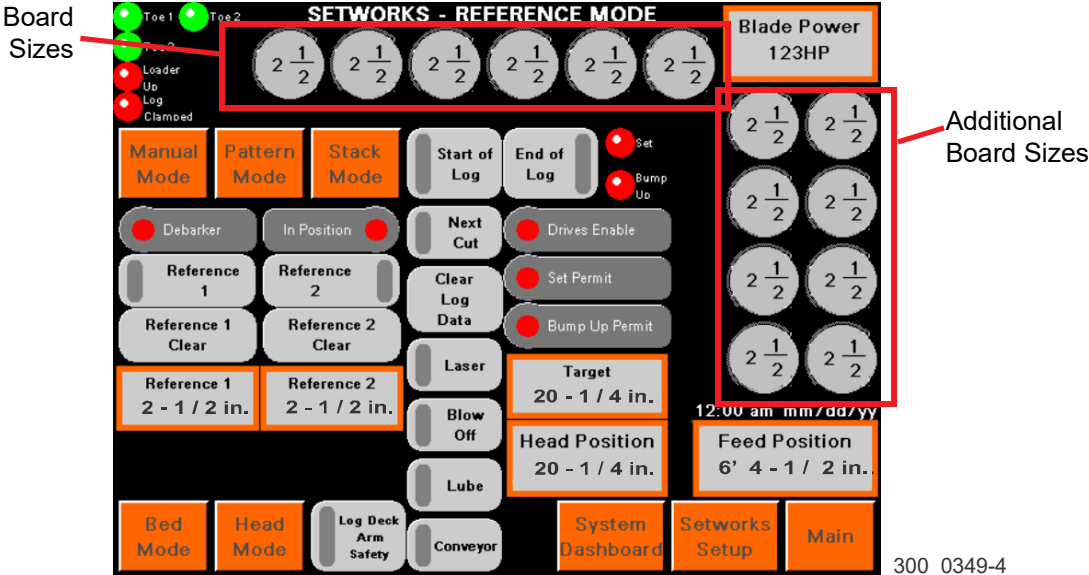

FIG. 4-32

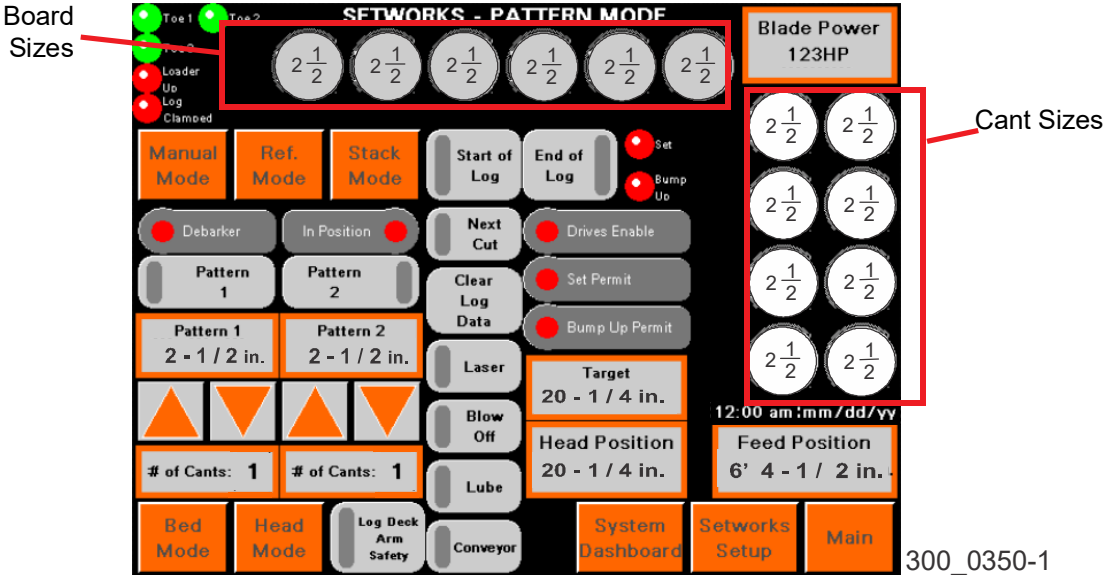

FIG. 4-33

4 Networks

Setworks Board/Cant Size Setup

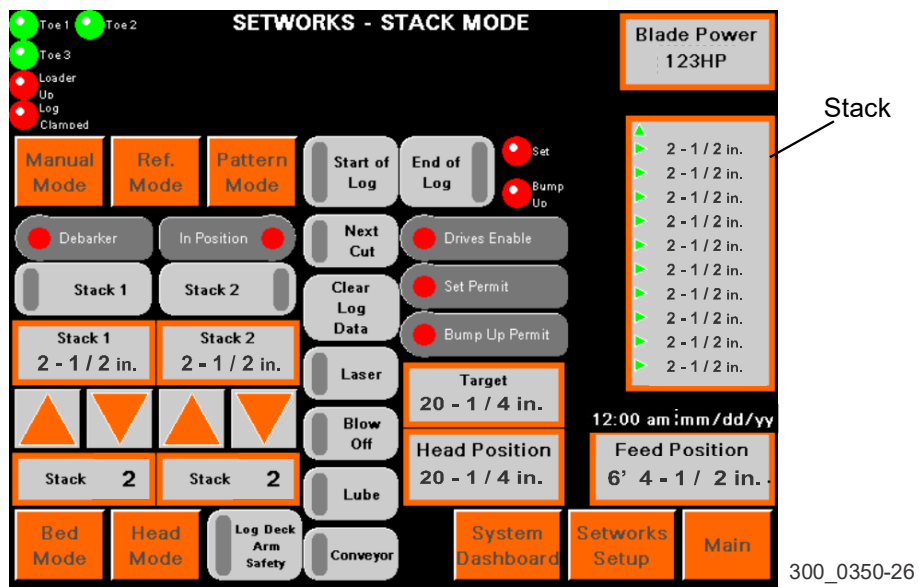
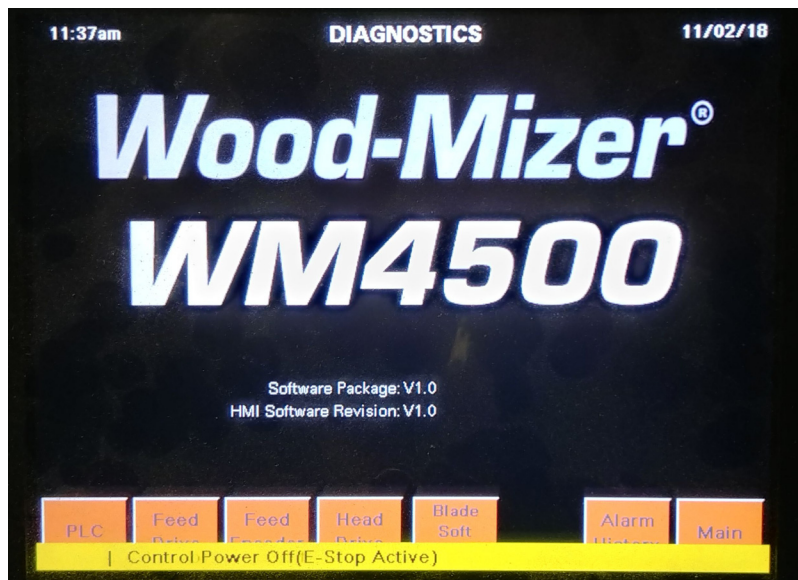

FIG. 4-34

4.5 Diagnostics

The diagnostic section of Setworks is used primarily in conjunction with Wood-Mizer Customer Support.

When troubleshooting, Customer Service may ask you to go to one of these screens for information.



300_0350-6

FIG. 4-35

PLC 1 - 7

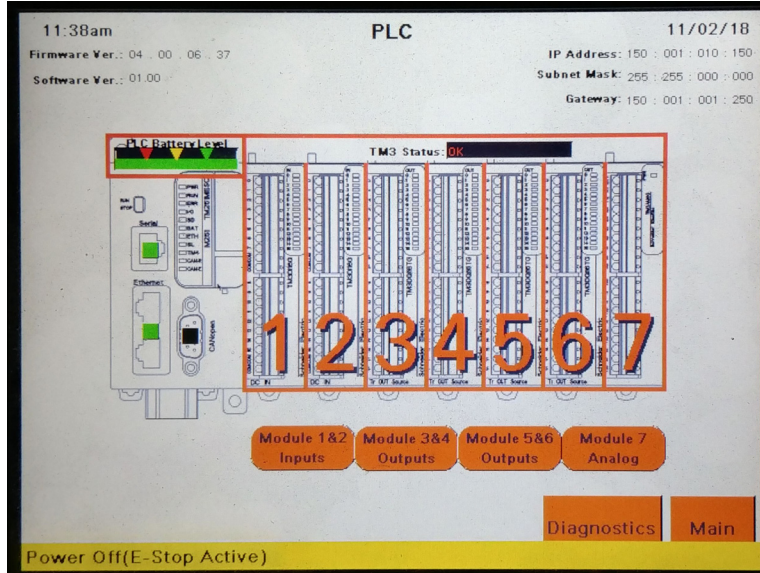

300_0350-11

FIG. 4-36

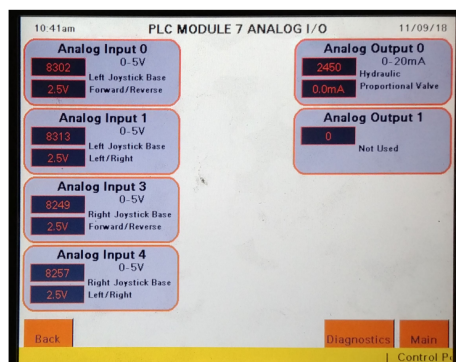
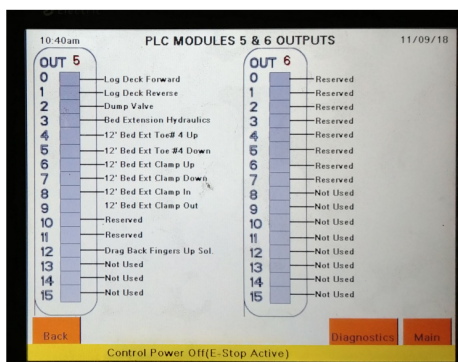
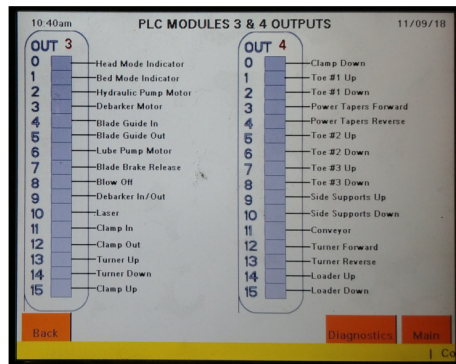
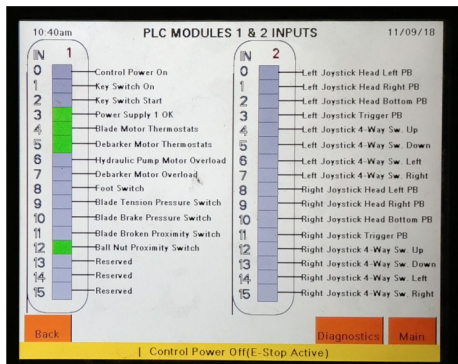

300_0350-28

FIG. 4-37

Feed Drive 1 & 2

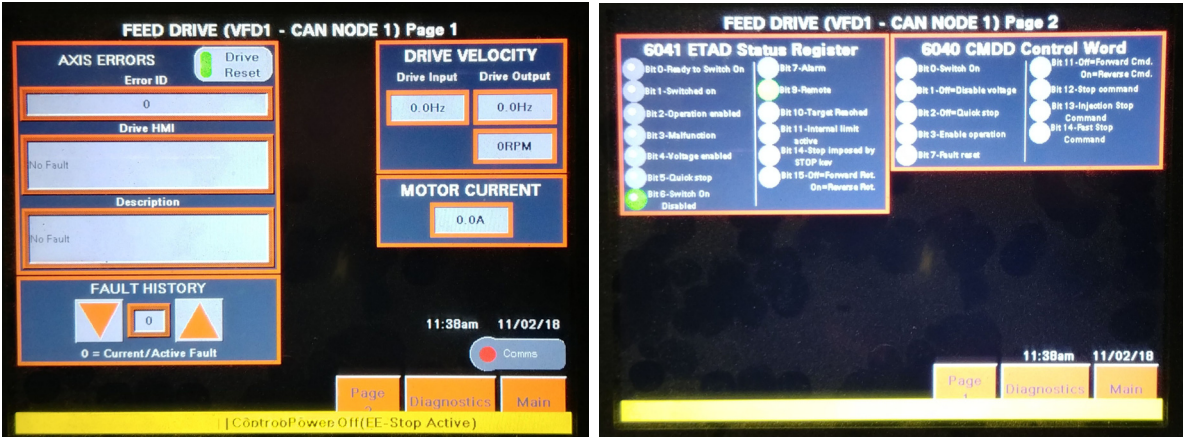

300_0350-12

FIG. 4-38

Head Drive 1 & 2

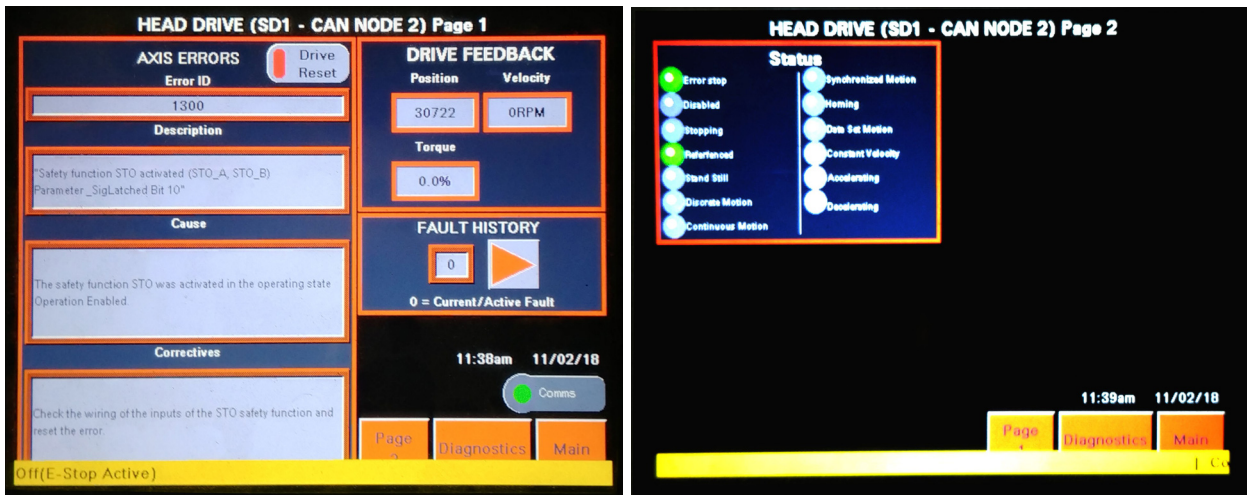

300_0350-23

FIG. 4-39

Blade Soft Start 1 & 2

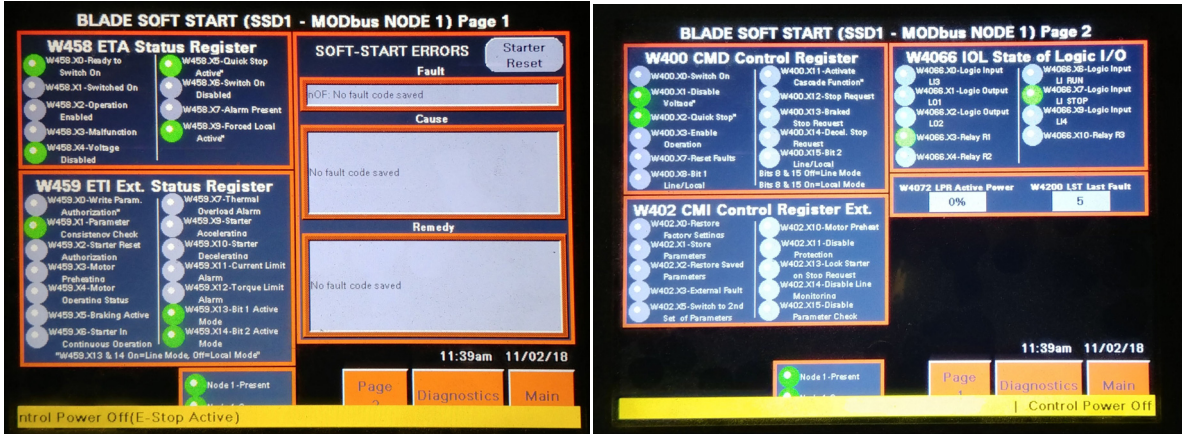

300_0350-29

FIG. 4-40

SECTION 5 ALIGNMENT

NOTICE These procedures build on each other. It is important to do these in this sequence.

5.1 Bed Frame

Level Bed Frame Along the Length

NOTE: Level the sawmill in the length direction as closely as possible. **This is critical to maintain sawing accuracy.**

1. Move the saw head so it is positioned over the log clamp tube at the middle of the bed frame.



CAUTION! Avoid raising or lowering the saw head against the upper or lower travel limits until after the transducer has been properly adjusted. Failure to do so may result in damage to the machine.

2. Set the laser level beam five inches above the top track rail.
3. Measure the distance from the top track rail to the laser beam at four equal locations along the tube.
4. Once you have four measurements, determine a target dimension that splits the difference of the four dimensions taken.

EXAMPLE: Four dimensions from track rail to the laser beam are as shown in Table 5-1. The 1/4" (6mm) dimension (mode) should be the target as this will require the least adjustment at each location.

Front	Front Middle	Rear Middle	Rear	Target
1/4" (6mm)	0"	1/2"	1/4" (6mm)	1/4" (6mm)

TABLE 5-1

5. Measure the distance from the top track rail to the laser beam at one of the leg locations.
6. Move the saw head as necessary to remove weight from the leg.

5**Alignment***Level Bed Frame Along the Width*

7. Use the shims to raise or lower the appropriate leg until the target dimension is obtained ($\pm 1/16''$ (1.5mm)).

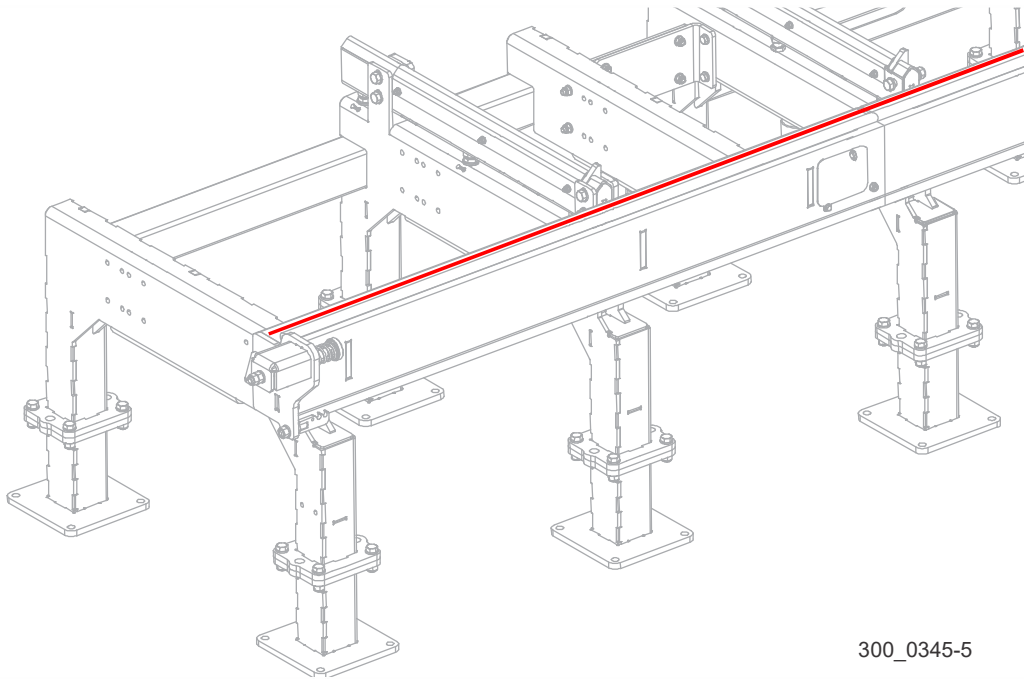

300_0345-5

FIG. 5-1

8. Move the saw head back to the rear of the bed (furthest from operator station).
9. Measure the distance from the top track rail to the laser beam at the bed rail location.

If the measurement is more than $1/16''$ (1.5mm) more or less than the target dimension determined above, shim one of the two middle inside legs to push or pull the tube until it is level.

Level Bed Frame Along the Width

10. Place two pieces of straight tubing between the front two bed rail supports.
11. Measure from the front end of each tube to the laser beam.
12. Shim the outer front leg to level the bed so both measurements to the tubes are the same ($\pm 1/16''$ (1.5m)).
13. Repeat at the other end of the tubes using the second outer leg to adjust.

14. Move the straight tubes to the rear two bed rail supports and adjust the two outer rear legs until the bed is level ($\pm 1/16"$ (1.5m)).

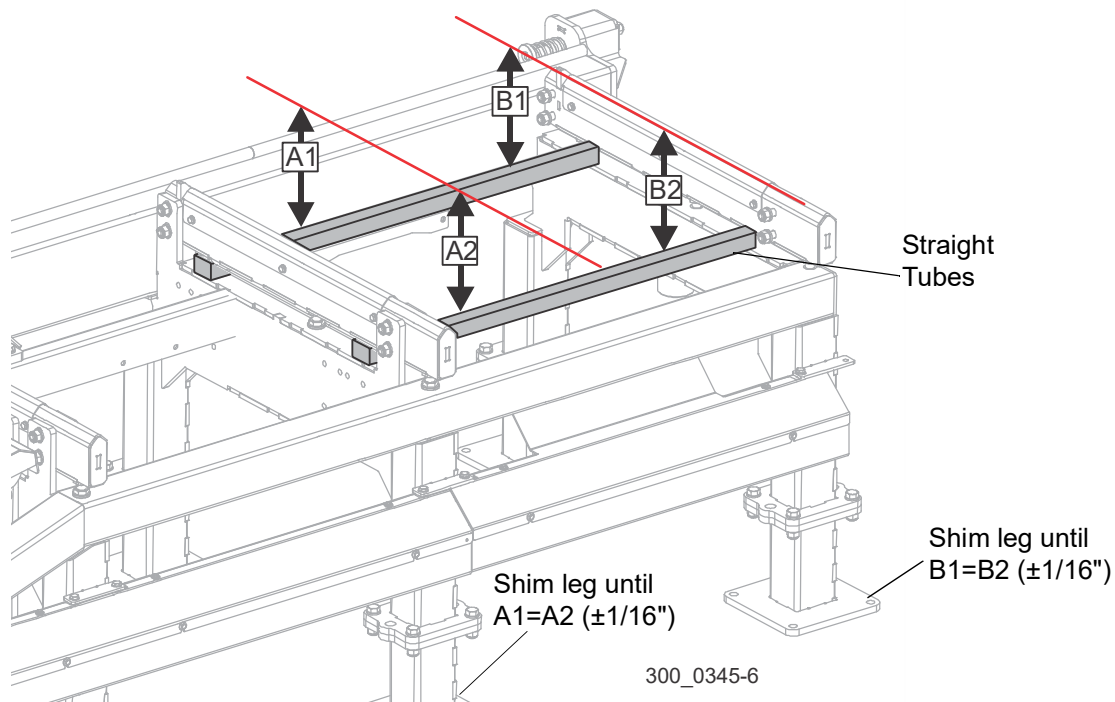

FIG. 5-2

Level Saw Head

1. Install, tension, and track a blade.
2. Move the saw carriage so the blade is positioned over the log clamp tube.
3. Adjust the blade guide arm all the way out.
4. Adjust the blade guides so they do not touch the blade.

5 Alignment

Level Saw Head

5. Loosen adjustment screws as necessary to move roller away from blade.

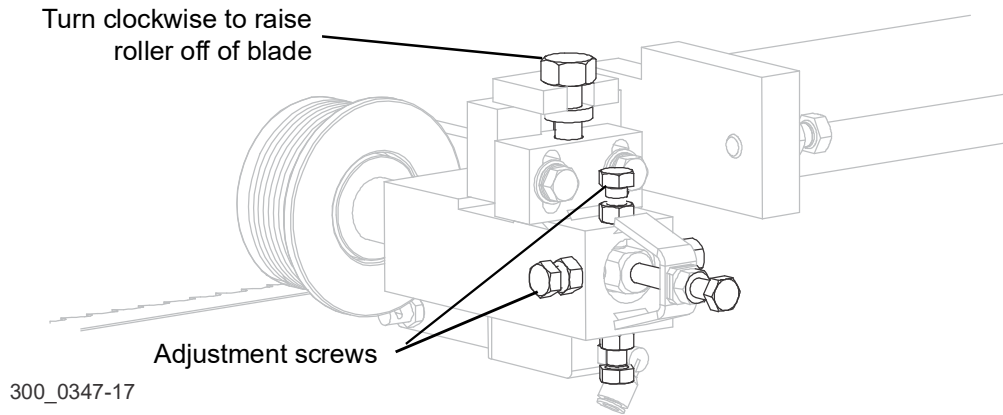

FIG. 5-3

6. Check that the blade guide roller does not touch the blade.
7. Raise the saw head until the blade measures 15" above the clamp tube (actual measurement with a tape or rule) from the bottom of the blade to the clamp tube near the **inner** blade guide.
8. Measure the distance to the blade at the **outer** end of the clamp tube.

NOTE: The two measurements should be equal. If necessary, adjust the lower track rollers to tilt the saw head so the blade is parallel to the clamp tube.

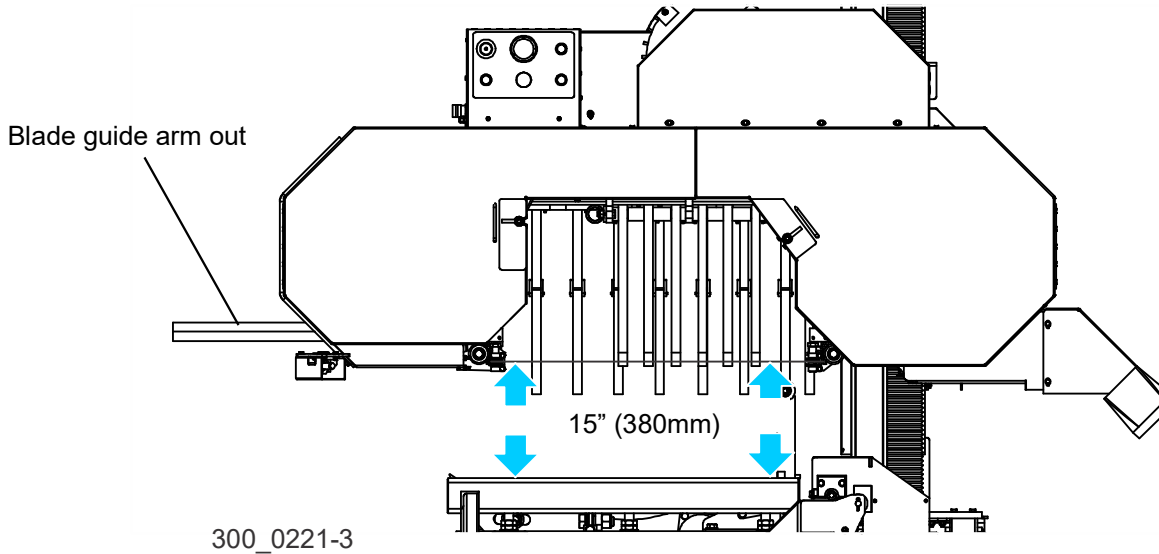

FIG. 5-1

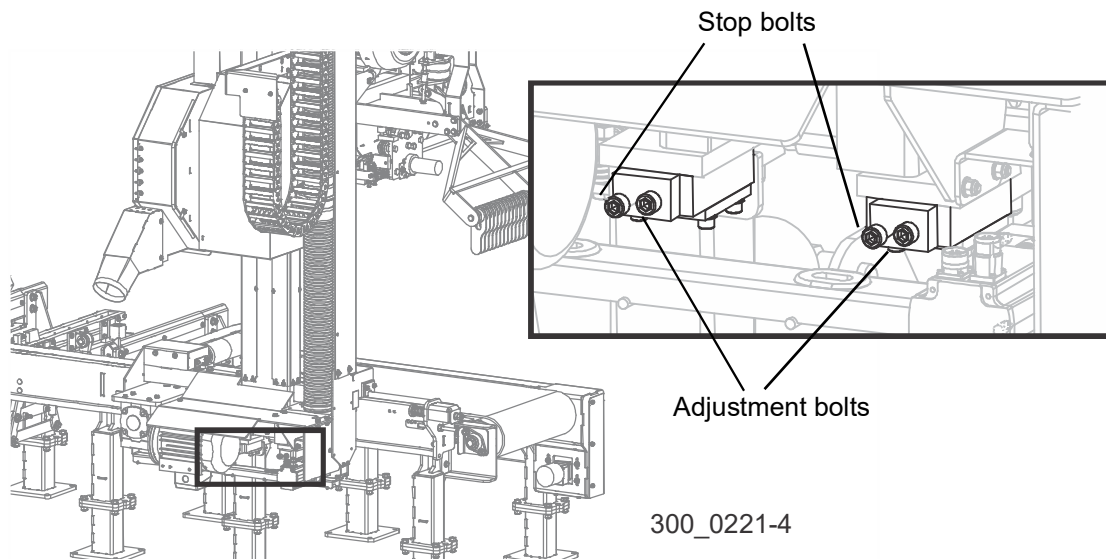

FIG. 5-4

9. Tilt the outer side of the saw head down toward the bed by loosening the adjustment bolts.

5 Alignment

Level Bed Rails

10. Turn each adjustment bolt equally, one revolution at a time and remeasure the distance from the blade to the clamp tube until the blade is parallel to the clamp tube.
11. Tighten the stop bolts until they stop against the roller mount block.
12. Tilt the outer side of the saw head up by loosening the stop bolts and tighten the adjustment bolts.
13. Turn each adjustment bolt equally, one revolution at a time and remeasure the distance from the blade to the clamp tube until the blade is parallel to the clamp tube.
14. Tighten the stop bolts until they stop against the roller mount block.

Level Bed Rails

This should be performed using the same sawhead height at set in the previous alignment.

1. Move the saw carriage so the blade is positioned over the front bed rail.

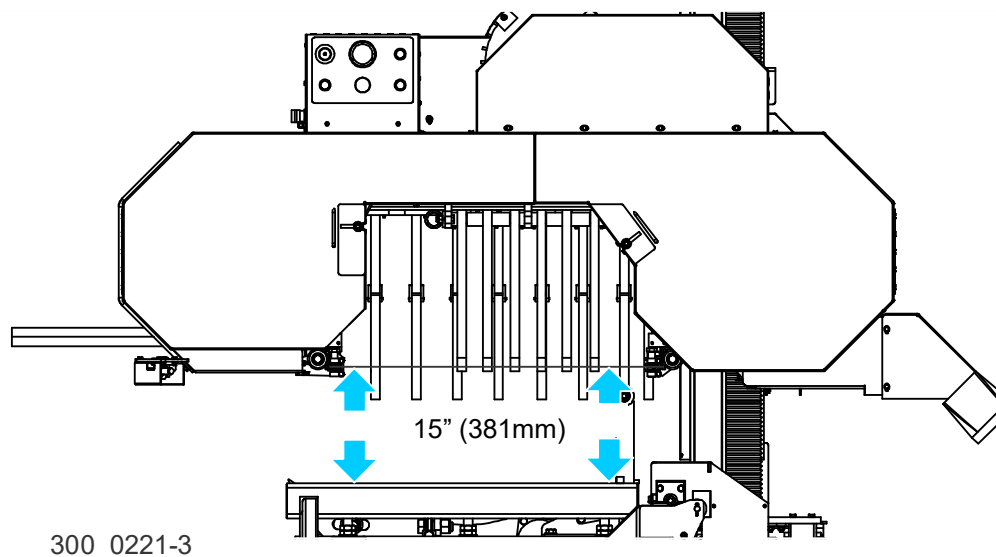

FIG. 5-5

2. Measure the distance from the bottom of the blade to the bed rail at each end of the bed rail.

NOTE: Both measurements should be 15" (381mm) \pm 1/16" (1.5mm).

3. Loosen the rail mounting bolts.

4. Turn the bed rail adjustment nuts to raise or lower the bed rail as necessary.
5. Tighten the mounting bolts.

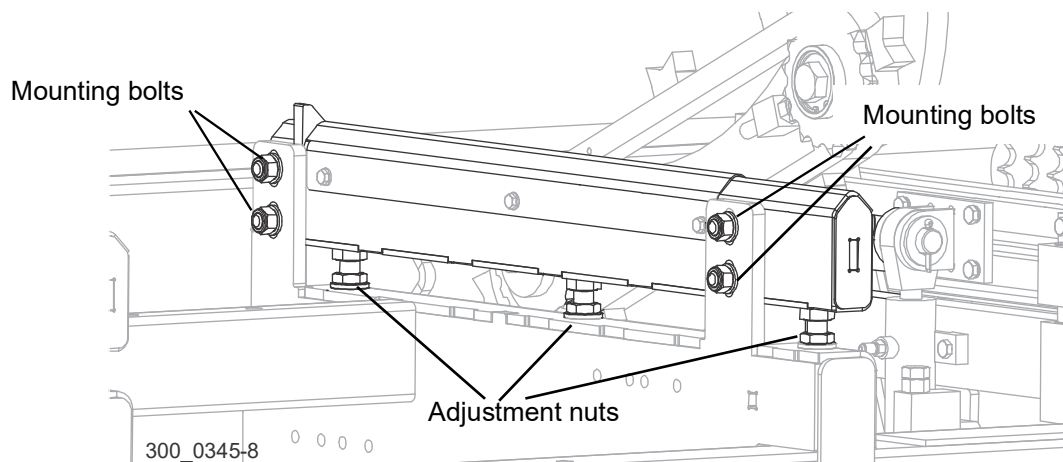

FIG. 5-1

6. Repeat for the remaining bed rails.

Align Side Supports

1. Place identical square tubes across the bed rails in front of one of the side supports.
2. Use the controls to raise the side supports all the way up.
3. Set a square on the tubes and place against the side support.

- The side support should be square to the bed or tilted slightly forward $1/32$ " (0.8 mm).

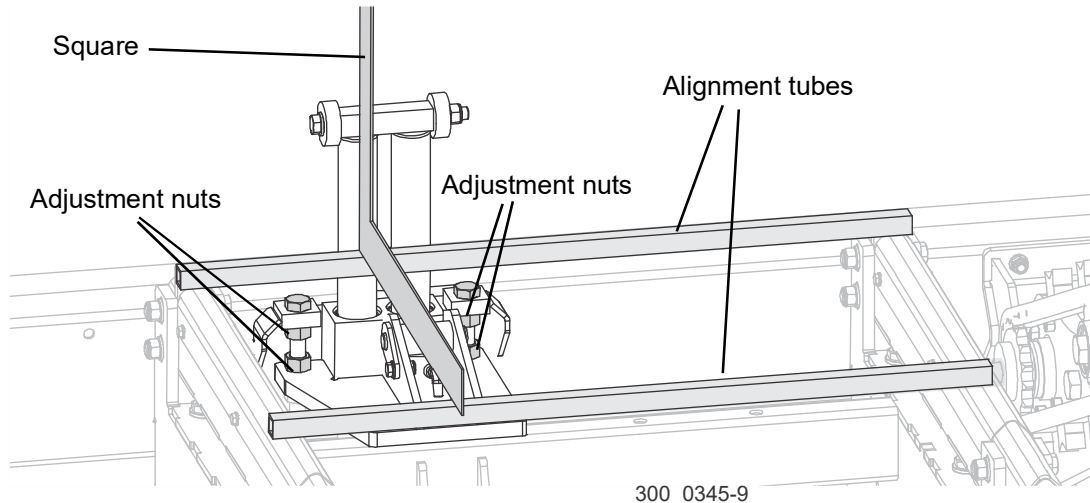

FIG. 5-6

- Tilt the side support forward by loosening the top adjustment nuts and tighten the lower adjustment nuts.
- Adjust both sets of adjustment nuts on each side of the side support evenly.
- Tilt the side support back by loosening the bottom adjustment nuts and tighten the top adjustment nuts.
- Repeat for all side supports.

5.2 Blade Guides



DANGER! Before performing service near moving parts such as blades, pulleys, motors, belts and chains, first turn the power off and lockout the system ([See Section 2.3](#)). Failure to follow this could result in serious injury or death.



DANGER! DO NOT use blades with stress cracks. Failure to follow this will result in serious injury or death.

If the blade breaks during operation and the blade has multiple stress cracks, the blade could shatter into several pieces and escape from the protective guards of the sawmill.

Small blade pieces projected into the area around the sawmill creates a safety hazard for the operator and any bystanders surrounding the mill.

NOTICE Blade guide alignment is essential for optimal cutting performance, blade life, and safety.

Failure to check and maintain proper blade guide alignment will result in stress cracks forming in the blade leading to premature blade breakage.

Blade Guide Adjustment Overview

NOTICE The stationary blade guide mounted on the drive side is referred to as the “Inner” blade guide; The blade guide mounted on the adjustable blade guide arm is referred to as the “outer” blade guide.

Proper blade guide alignment is critical to optimum machine performance. **Understand and follow the procedures in this section to properly align the blade guides.**

The objective to aligning the blade guides is to properly position the guide roller in relation to the blade.

- The roller should deflect the blade down 1/4” (6mm).
- The flange of the outer guide roller should be positioned 1/8” (3mm) from the back edge of the blade.

5

Alignment

Blade Guide Adjustment Overview

- The flange of the inner guide roller should be positioned 1/16" (1.5mm) from the back edge of the blade.

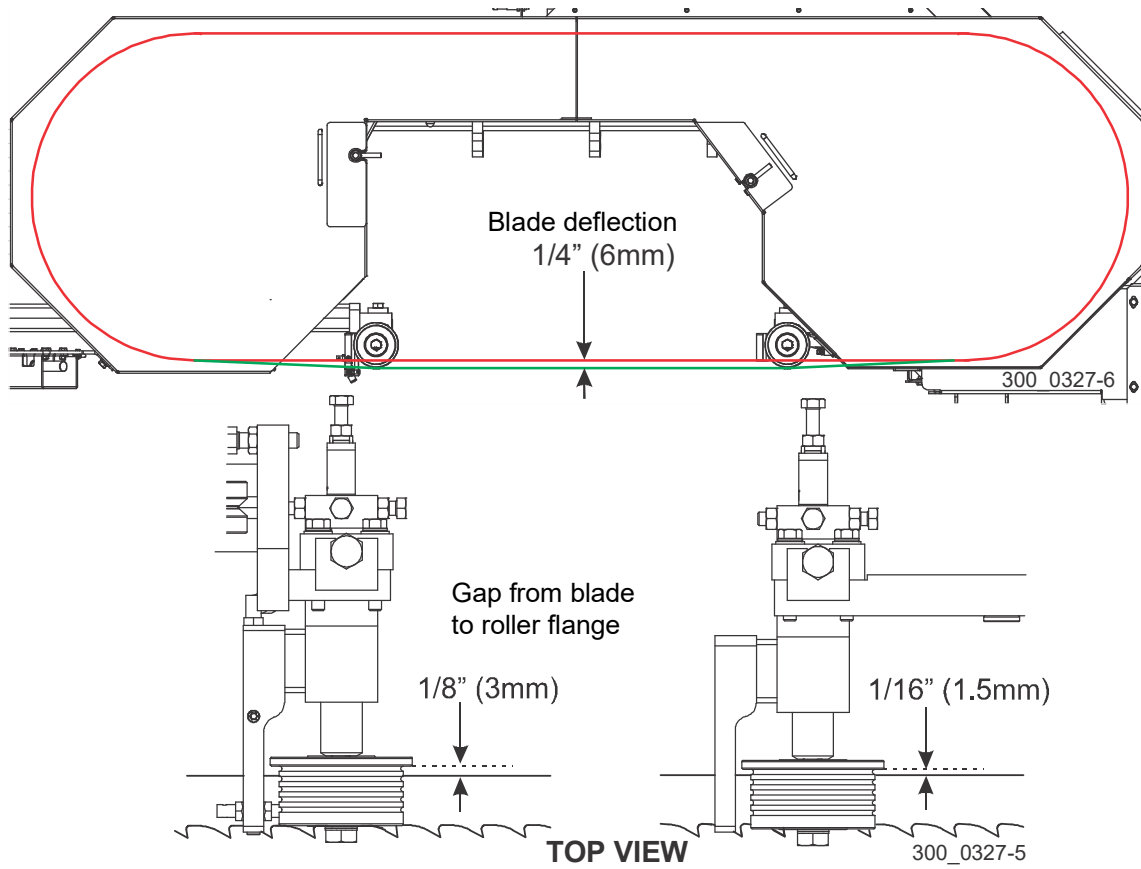

FIG. 5-7

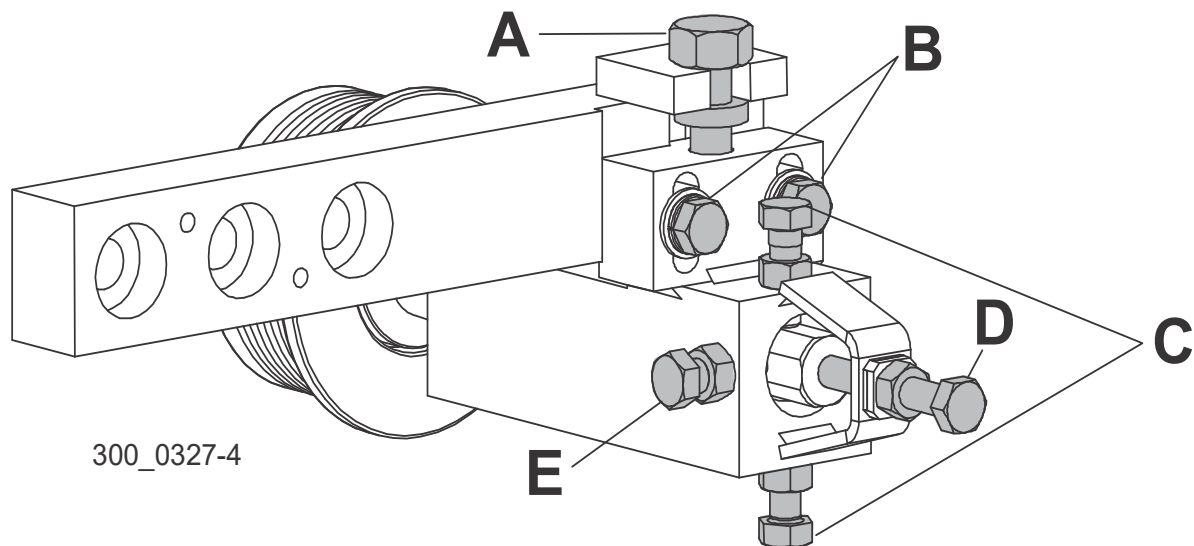

FIG. 5-8 ADJUSTMENT BOLTS

A - Vertical Adjustment Bolt - Adjusts entire blade guide assembly up or down. Turn clockwise to raise assembly; counterclockwise to lower assembly.

B - Blade Guide Assembly Clamp Bolts - Secures vertical adjustment of entire blade guide assembly.

C - Vertical Tilt Adjustment Bolts - Tilts the entire blade so it is parallel to the bed rails.

D - Horizontal Adjustment Bolt - Adjusts roller shaft in or out from mounting block.

E - Blade Guide Clamp Bolt - Holds blade guide assembly securely in mounting bracket.

Preparing For Blade Guide Alignment

Recommended tools:

- Wrenches: 1/2", 9/16", 3/4", & 1"
- 5/16" Nut Driver
- 5/32" Hex Wrench
- Blade Guide Alignment Tool (LTBGAT)
- Blade Guide Arm Alignment Tool (042700)
- Flashlight

1. Remove the blade and replace the blade wheel belts.

NOTE: New blade wheel belts are required to perform the complete alignment procedure.

2. Blow sawdust off of the blade guide assemblies. Remove sawdust from the blade housings.
3. Remove the blade guide assemblies.

NOTE: To remove the blade guide assemblies and maintain the tilt adjustments, only loosen one side screw and the top screw. Leaving the other side screw and bottom screw in position will insure you will return the rollers to their original tilt adjustment.

4. Adjust the outer blade guide arm until the outer blade guide is approximately 24" from the inner blade guide.
5. Install a new blade and apply the appropriate tension ([See Section 4.6](#)).
6. Close the blade housing covers and make sure all persons are clear of the saw head.
7. Start the engine (or motor).
8. Engage the blade, rotating the blade until the blade positions itself on the wheels.



WARNING! Do not spin the blade wheels by hand. Spinning the blade wheels by hand may result in serious injury.

9. Disengage the blade. Turn the engine off and remove the key.

Blade Wheel Vertical Alignment

1. Attach the blade guide alignment tool to the blade near the inner blade guide.

NOTICE Be sure the tool does not rest on a tooth or burr, and is lying flat on the bottom of the blade.

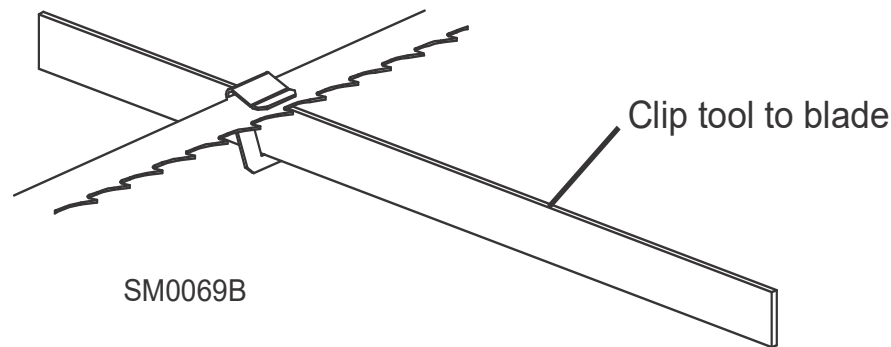

FIG. 5-9

2. Move the saw carriage so the front end of the tool is positioned over the first bed rail.
3. Measure from the bottom of the tool to the top surface of the bed rail.
4. Move the saw carriage so the rear of the tool is positioned over the bed rail.
5. Again, measure from the bottom of the tool to the bed rail.
6. Adjust the vertical tilt of the drive-side blade wheel until the two measurements within 1/16"(1.5mm) of each other.
 - Remove the drive-side cover and locate the vertical tilt adjustment bolts.
 - Loosen the jam nuts on each bolt.
 - Adjust the bolts down to tilt the blade up.
 - Adjust the bolts up to tilt the blade down.

5

Alignment

Blade Wheel Vertical Alignment

- Retighten the jam nuts and recheck the tilt of the blade with the blade guide alignment tool.

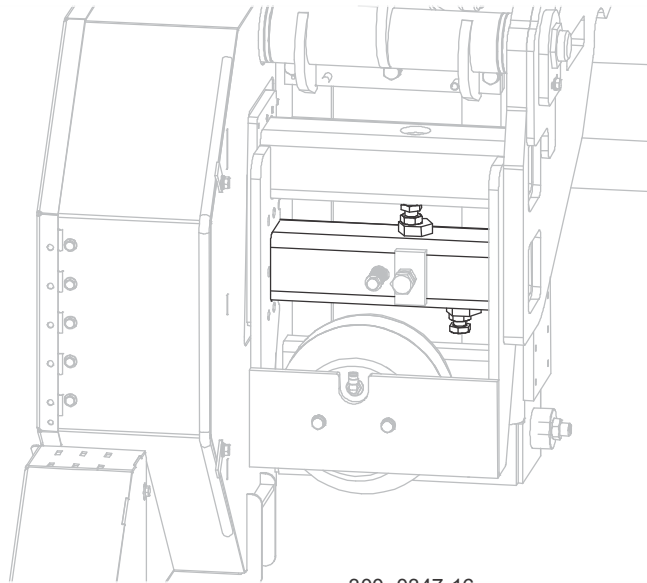

FIG. 5-10

7. Remove the tool from the blade and reattach it near the outer blade guide assembly.
8. Measure from the tool to the bed rail at both ends of the tool.
9. If the measurements at the front and rear ends of the tool are not equal within 1/16" (1.5mm), adjust the vertical tilt of the idle-side blade wheel.
 - Loosen the jam nuts on each bolt.
 - Adjust the bolts down to tilt the blade up.
 - Adjust the bolts up to tilt the blade down.

- Retighten the jam nuts and recheck the tilt of the blade with the blade guide alignment tool.

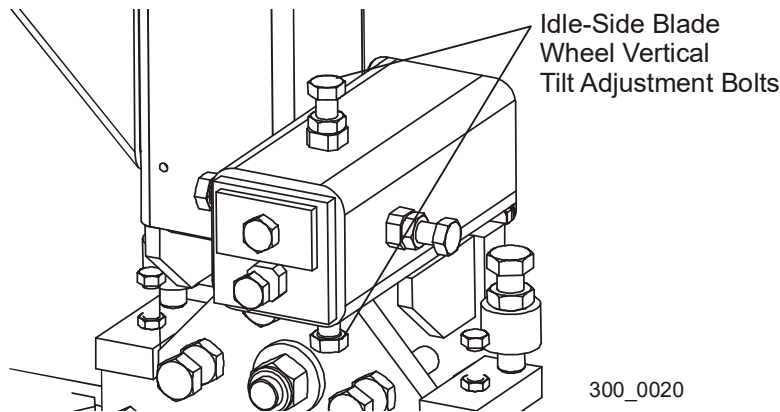

FIG. 5-11

Blade Guide Arm Alignment

1. Move the blade guide arm all the way in toward the inner blade guide assembly.
2. Attach the blade guide arm alignment tool (p/n 042700) to the blade guide arm, near the outer blade housing.
3. Measure the distance from the back edge of the blade to the tool.
4. Move the tool to the end of the arm near the blade guide.
5. Measure again from the back edge of the blade to the tool.

The two measurements at each end of the arm should be the same within 1/32" (0.8mm).

- To adjust the horizontal tilt of the arm parallel to the blade, adjust the bolts (A & B) on the blade guide arm mounting plate.
- Loosen the jam nuts.
- Adjust bolt (A) out and bolt (B) in to move the arm away from the blade.
- Adjust bolt (B) out and bolt (A) in to move the arm toward the blade.
- Recheck the distance from the back edge of the blade to the tool at both ends of the arm.

5

Alignment*Blade Guide Arm Alignment*

- Readjust as necessary.
- Tighten the jam nuts.

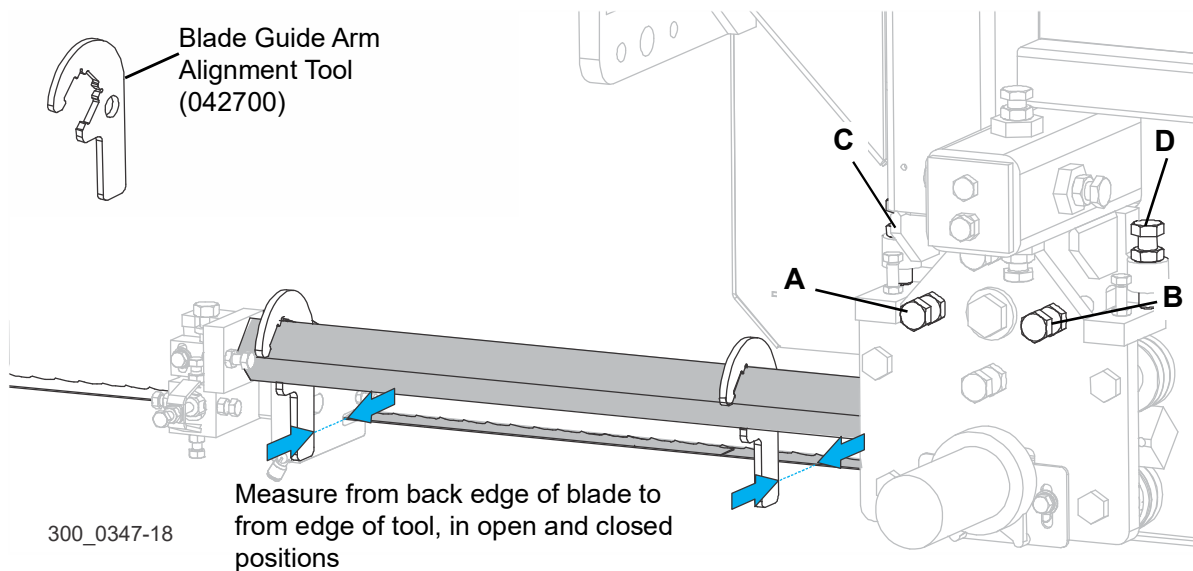
**FIG. 5-12**

6. Adjust the blade guide arm in near the inner blade guide.
7. Measure the distance from the top of the blade to the bottom of the roller.
8. Adjust the blade guide arm all the way out and measure again.

If the two measurements are not equal with $1/32"$ (0.8mm), adjust the vertical tilt of the blade guide arm.

- Adjust the bolts (C & D) on the blade guide arm mounting plate.
- Loosen the jam nuts.
- Adjust bolt (C) up and bolt (D) down to tilt the arm up.
- Adjust bolt (D) up and bolt (C) in to move the arm toward the blade.
- Recheck the distance from the blade to the bottom of the roller at both ends of the arm.
- Readjust as necessary.

- Tighten the jam nuts

Blade Guide Alignment

NOTE: Before installing the blade guide assemblies, remove the blade guide adjusting screws and apply a lubricating oil such as 10W30 or Dexron III to each screw. This will prevent the screws and threaded holes from corroding and make screw adjustments easier.

1. Inspect the guide rollers and replace as necessary.
2. Remove the blade from the sawmill.
3. Install each blade guide assembly to the mounting blocks and push all the way back.
4. Install, tension, and track a new blade.
5. Adjust the outer blade guide assembly so the roller flange is 1/8" (3mm) and the inner blade guide assembly so the roller flange is 1/16" (1.5mm) from the back of the blade.
 - 1). Turn the top adjustment bolt clockwise to raise the blade guide assembly so the roller does not contact the blade.

NOTE: Before adjusting the top bolt, unload pressure on the bolt by turning 1/2 turn in the opposite direction it was last adjusted.

- 2). Adjust shaft screw to move the roller flange to 1/8" (3mm) (outer) or 1/16" (1.5mm) (inner) from back of blade.

- 3). Tighten tilt screws (4) to secure the assembly in place.

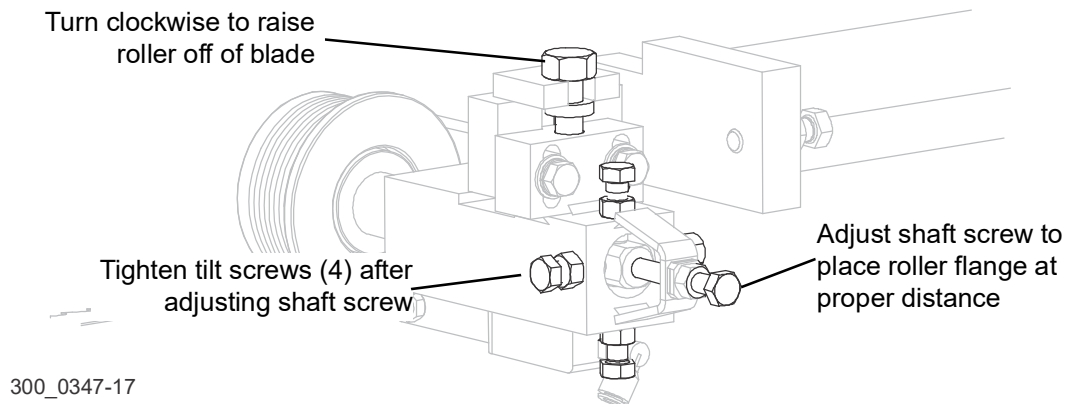
**FIG. 5-13*****Blade Guide Assemblies Downward Deflection***

1. Raise the saw head until the blade is 15" (375 mm) above a bed rail.
2. Measure the actual distance from the top of the rail to the bottom of the blade.

NOTICE Be sure the measurement is not taken on a tooth or burr, but rather the flat of the blade.

3. Turn the top adjustment bolt counterclockwise until the blade guide roller deflects the blade down until the bottom of the blade measures 14 3/4" (370 mm) from the bed rail.

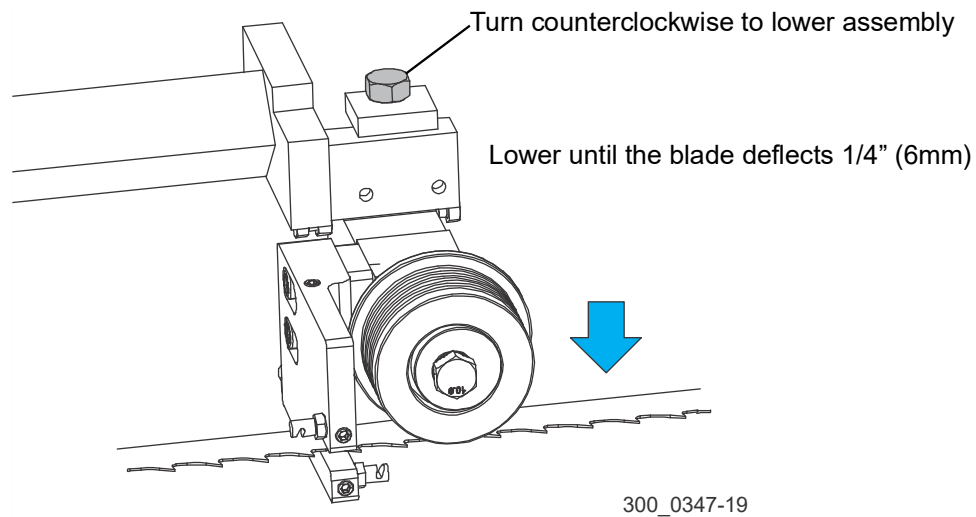

FIG. 5-14

NOTE: Before adjusting the top bolt, unload pressure on the bolt by turning 1/2 turn in the opposite direction it was last adjusted.

4. Repeat for the other blade guide.

Blade Guide Vertical Alignment

If the blade guides are tilted vertically, the blade will try to travel in the tilted direction.

1. Open the adjustable blade guide arm 1/2" (15 mm) from full open.
2. Clamp the blade guide alignment tool (p/n LTBGAT) on the blade.
3. Position the tool close to the outer blade guide roller.

5

Alignment

Blade Guide Vertical Alignment

NOTICE Be sure the tool does not rest on a tooth or burr, and is lying flat on the blade.

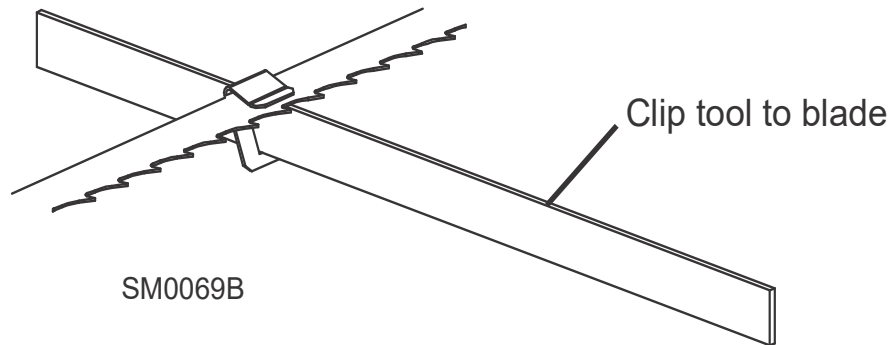

FIG. 5-15

4. Move the carriage so that the front end of the tool is positioned above the bed rail.
5. Measure the distance from the bed rail to the bottom edge of the tool.
6. Move the carriage so that the back end of the tool is positioned above the bed rail.
7. Measure the distance from the bed rail to the bottom edge of the tool.
8. If the measurement from the tool to the bed rail is not equal within 1/32" (.75 mm), adjust the vertical tilt of the outer blade guide roller.
9. Loosen one set screw at the side of the blade guide assembly.
10. Loosen the jam nuts on the top and bottom vertical tilt adjustment screws.
 - To tilt the roller up, loosen the bottom screw and tighten top screw.
 - To tilt the roller down, loosen the top screw and tighten the bottom screw.
 - Tighten the jam nuts.

- Recheck the tilt of the blade.

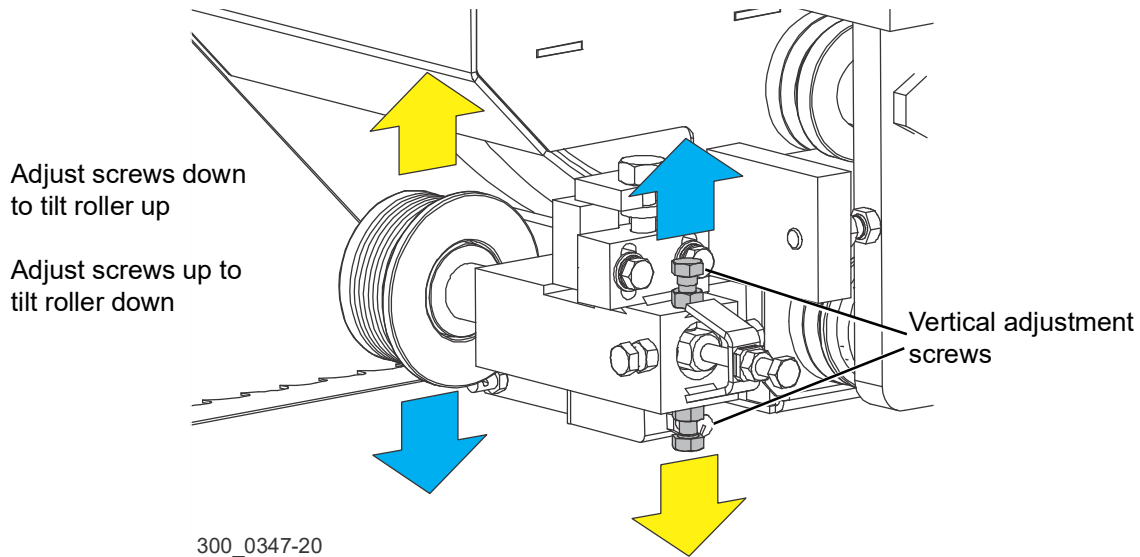

FIG. 5-16

11. Move the blade guide alignment tool close to the inner blade guide roller assembly and repeat the above steps.
12. Adjust the vertical tilt of the inner blade guide as necessary.
13. After adjusting the vertical tilt of the blade guides, recheck the blade deflection and adjust as necessary.

NOTICE If the blade guides are tilted in the wrong direction horizontally, the back of the blade may contact the flange as the roller is spinning down, causing it to push the blade away from the guide roller.

Blade Guide Horizontal Alignment

14. Remove the blade guide alignment tool from the blade and adjust the blade guide arm halfway in.
15. Remove the clip from the blade guide alignment tool.

16. Place the tool against the face of the outer blade guide roller.

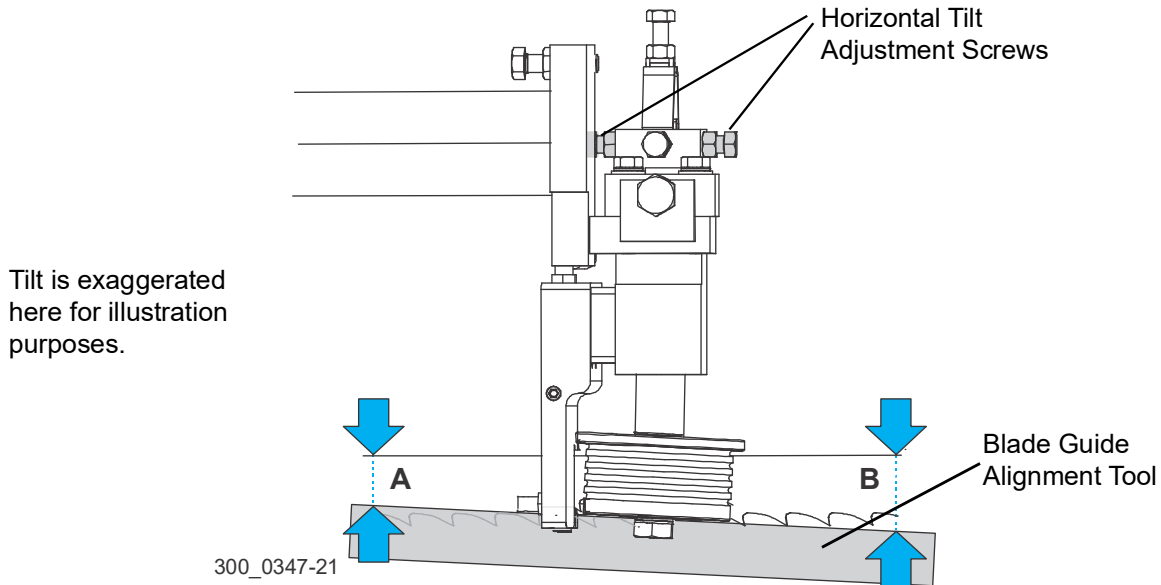

FIG. 5-17

17. Measure between the back edge of the blade and the tool at the end closest to the inner blade guide (B).
18. Measure between the back edge of the blade and the other end of the tool (A).

$$B - A = 1/8''(3\text{mm}) \pm 1/16'' (1.5\text{mm})$$

In other words, $B - A =$ a range between $1/16'' - 3/16'' (1.5\text{mm} - 4.5\text{mm})$

The roller should be slightly tilted as shown in Figure 5-17 (A $1/8'' [3 \text{ mm}]$ less than B $\pm 1/8'' [3 \text{ mm}]$).

19. Loosen the jam nuts on the horizontal tilt adjustment screws.
20. Loosen the right screw and tighten left screw or vice versa, depending on the adjustment necessary.

21. Tighten the jam nuts and recheck the tilt of the roller.

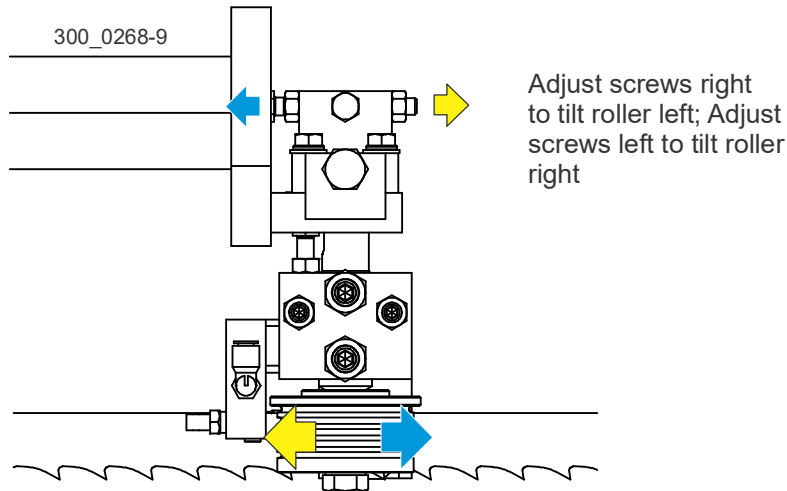

FIG. 5-18

22. Repeat the above steps for the inner blade guide roller assembly.

NOTE: Once the blade guides have been adjusted, any cutting variances are most likely caused by the blade. [See Blade Handbook, Form #600.](#)

23. Adjust the outer blade guide assembly so the **right edge** of roller flange is 1/8" (3mm) and the inner blade guide assembly so the **right edge** of roller flange is 1/16" (1.5mm) from the back of the blade.

NOTICE When adjusting blade guide spacing, loosen the top set screw and one side set screw **only**. This will ensure horizontal and vertical tilt adjustments are maintained when the adjustment screws are retightened.

- 1). Loosen the top and one side screw shown.
- 2). Back the stop bolt out of the way as necessary.
- 3). Tap the blade guide forward or backward until properly positioned.

5

Alignment

Blade Guide Horizontal Alignment

- 4). Retighten the screws and jam nuts.

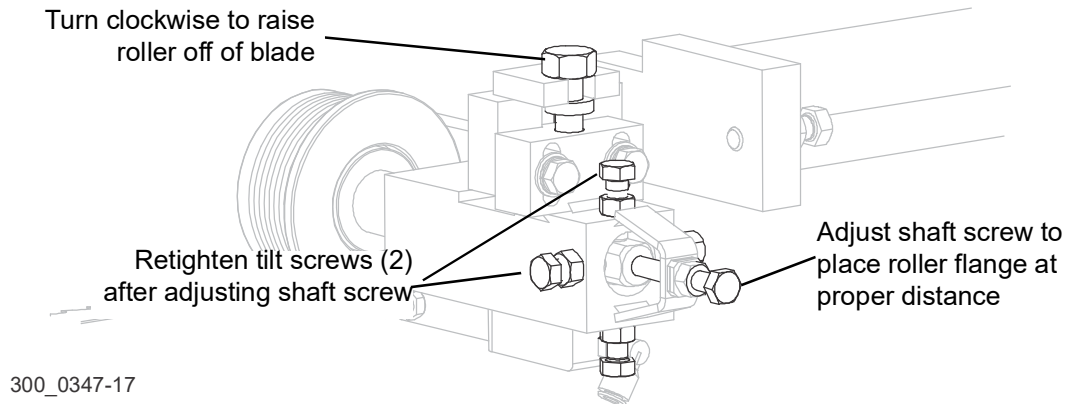

FIG. 5-19

24. Re-measure the distances between the **right edge** of the roller flanges to the back edge of the blade. (1/8" (3mm) for the outer roller and 1/16" (1.5mm) for the inner roller.)

SECTION 6 OPERATION

6.1 Control Overview

The controls allow the operator to control the sawing operation with minimal effort and movement. The control box includes controls to start and stop the machine. The operator interface is a touch screen used to set up the machine and diagnose problems.

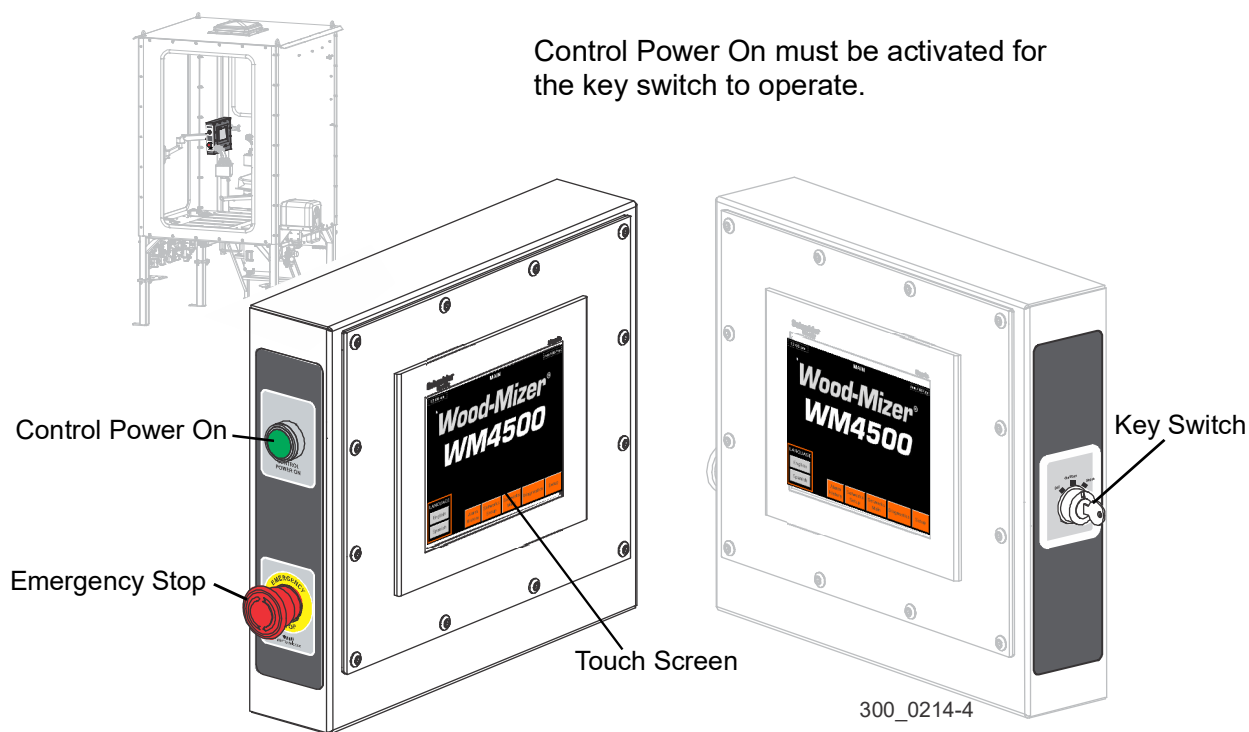

FIG. 6-1

CONTROL POWER ON: Controls power to the machine. When control power comes on, power returns to the feed drive, up/down drive, and blade soft-start. Push and release to turn on or off.

EMERGENCY STOP: Stops control power to the controls, feed drive, up/down drive, and blade soft-start. Press to stop power. To release, turn it clockwise until it pops out.

TOUCH SCREEN: Sets up the mill functions and controls the networks. Upon initial power-up, the touch screen displays the Home Screen, as shown in Figure 6-1.

KEY SWITCH: Enables control of the feed drive, up/down drive, and blade soft-start. Control Power On must be activated for the key to operate.

- In the **Off** position, the feed drive and the up/down drive will not function, and the blade brake will be engaged.
- In the **On/Run** position, the feed drive and up/down drive function.
- In the **Start** position, the blade motor starts and the feed drive and up/down drive are activated. Key returns to **On/Run** when released.

6.2 Distribution Box Overview

The distribution box is located on the top of the saw head, facing the operator.

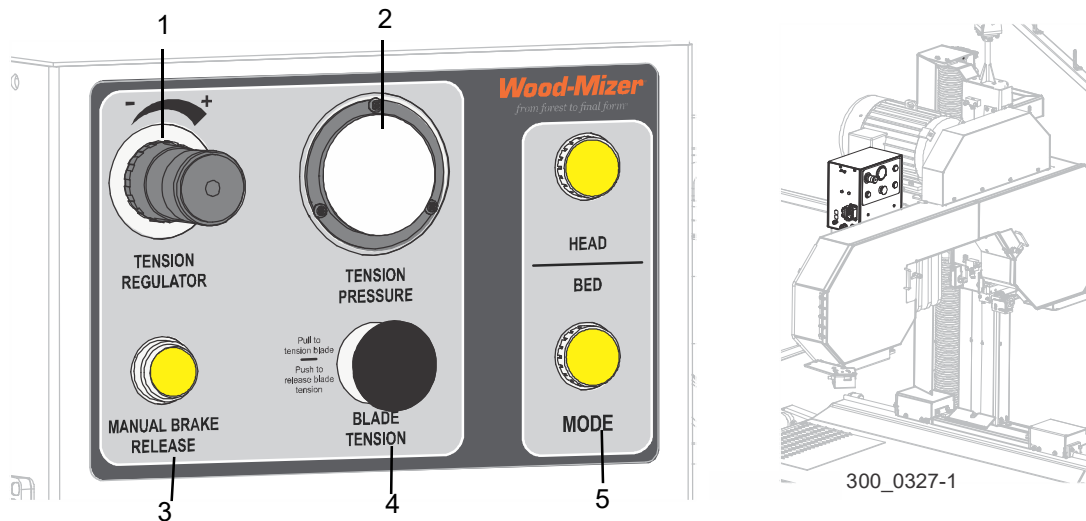

FIG. 6-2

1. **TENSION REGULATOR** - Adjusts the blade tension pressure.
Pull the knob out to unlock it.
Turn the knob to increase (clockwise) or decrease (counterclockwise) blade tension.
Push the knob back into to lock it.
2. **TENSION PRESSURE** - Gauge indicates current blade tension pressure.
3. **MANUAL BRAKE RELEASE** - Overrides the automatic brake when power is off.
Press and hold to release the blade wheel brake.
Release the button to engage the brake again.

NOTE: When control power is off, the blade brake is engaged. When changing blades it is sometimes necessary to spin the blade wheels.

4. **BLADE TENSION** - Sets/releases blade tension.
Pull out to tension the blade tension.
Push in to release the tension.
5. **MODE** - Indicate the current mode of the joystick controls.

HEAD - When lit, the joystick controls are in head mode.
BED - When lit, the joystick controls are in bed mode.

6.3 Joystick Control Overview

The joysticks are located on either side of the operator's seat. They control sawmill functions.

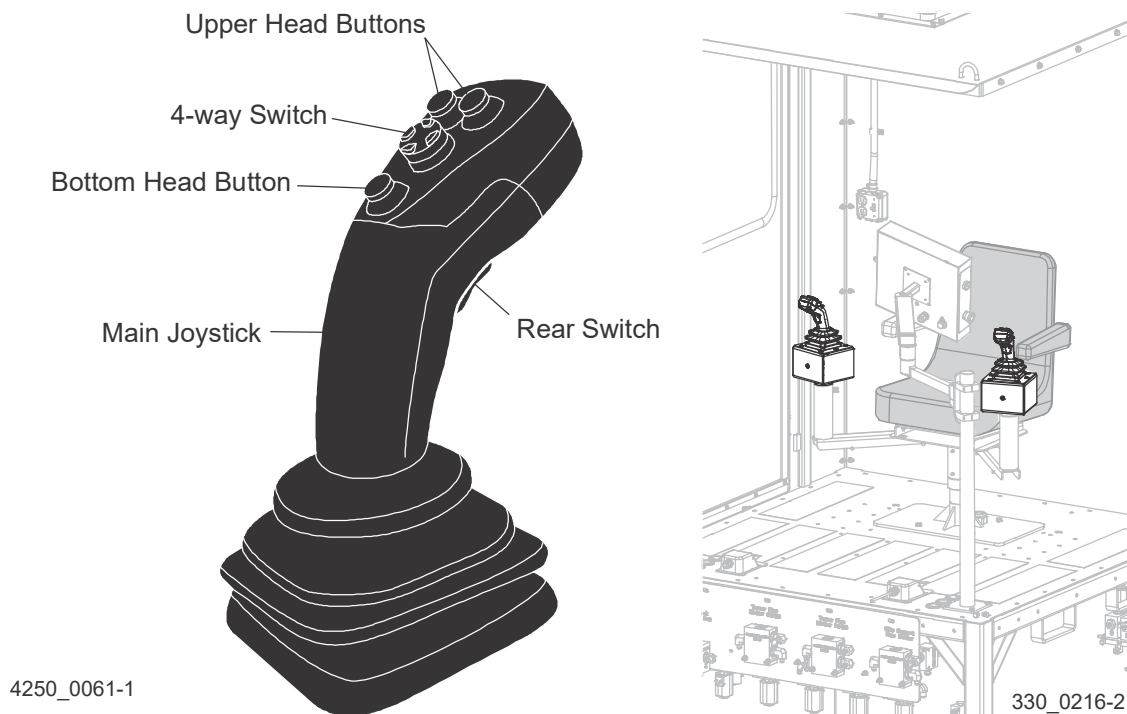

FIG. 6-3

The machine comes with three configurations of the joystick controls:

DEFAULT: Cannot be changed

USER 1: (Customizable) Use the control panel to change the joystick control layout and save.

USER 2: (Customizable) Use the control panel to change the joystick control layout and save.

NOTICE All of the reference in this section relate to the default layout.

Head Mode, Left Joystick

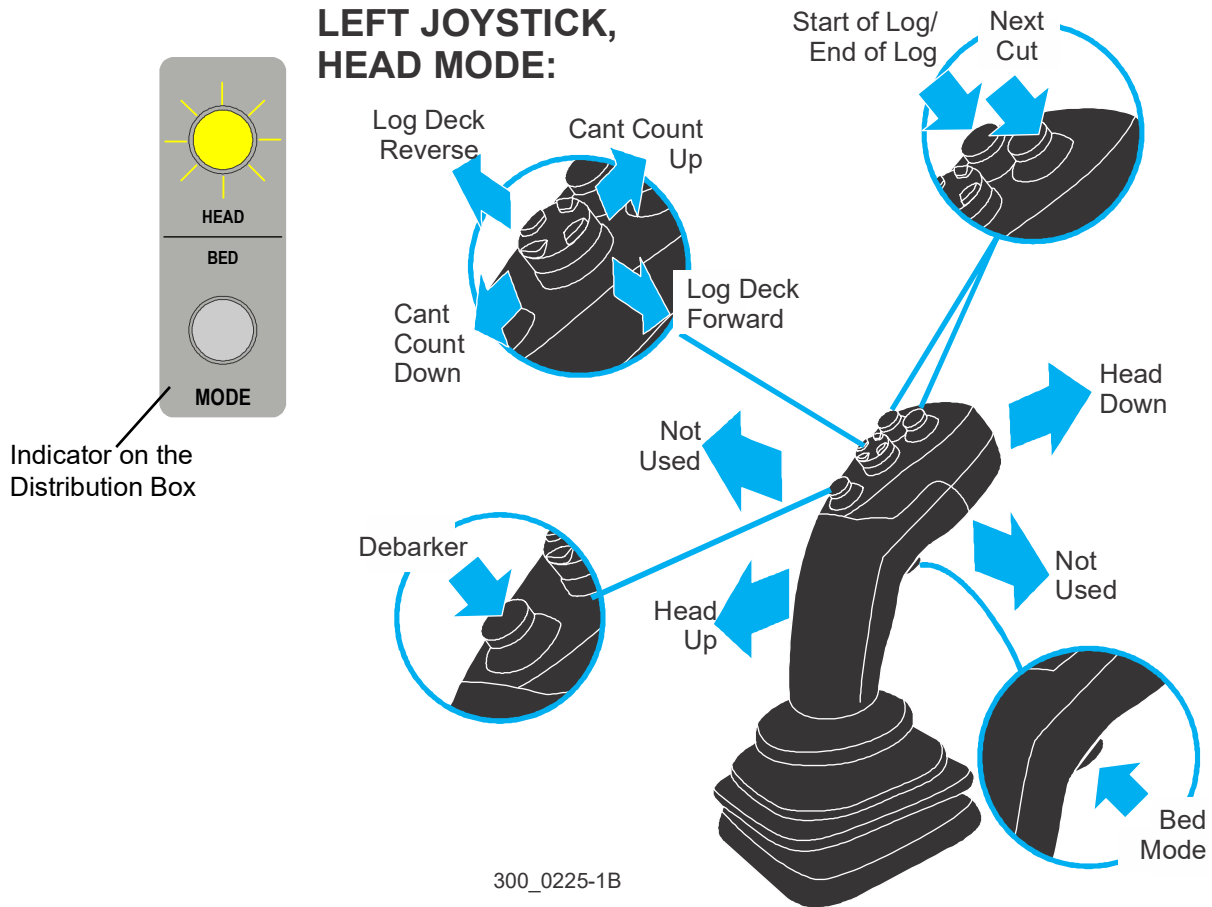

FIG. 6-4

FORWARD PUSH: Lowers the saw head.
The further the joystick is pushed, the faster the head moves down.

BACKWARD PULL: Raise the saw head.
The further the joystick is pulled, the faster the head moves up.

LEFT PUSH: *Not used.*

RIGHT PUSH: *Not used.*

TOP LEFT FRONT BUTTON: Sets either the Start of Log position or the End of Log position.

TOP RIGHT FRONT BUTTON: Toggles on/off Next Cut.

FOUR-WAY SWITCH UP: Increases the Cant Count in Pattern Mode.

FOUR-WAY SWITCH DOWN: Decreases the Cant Count in Pattern Mode.

FOUR-WAY SWITCH RIGHT: Move the log deck forward.

FOUR-WAY SWITCH LEFT: Reverses the log deck.

BOTTOM FRONT BUTTON: Starts the debarker operation.

REAR SWITCH: Toggles Mode.

Head Mode, Right Joystick

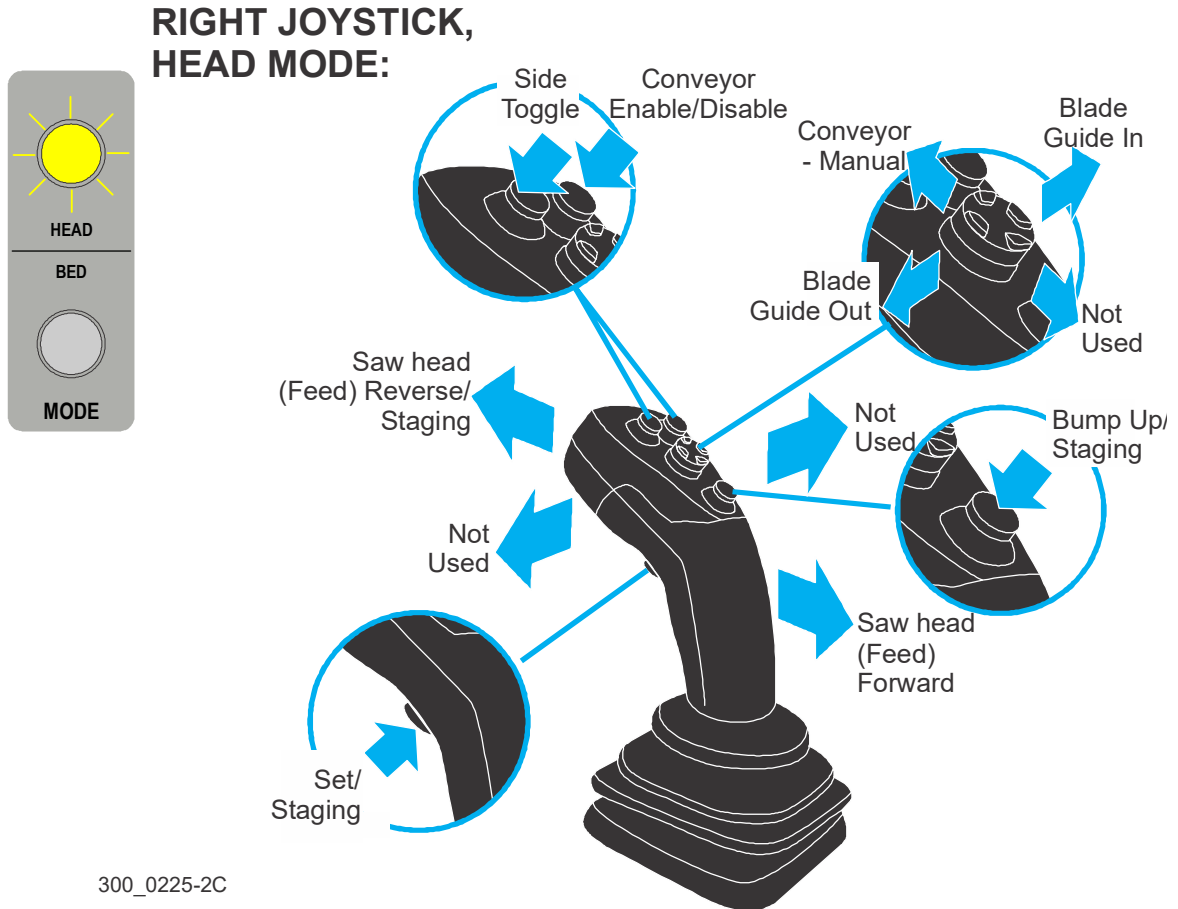

FIG. 6-5

FORWARD PUSH: Moves the saw head travel backwards. The further the joystick is pushed, the faster the head moves.

NOTE: While moving the head backward (joystick forward) and pressing both the set and bump up functions together initiates the staging position.

BACKWARD PULL: Moves the saw head travel forwards. The further the joystick is pulled, the faster the head moves.

LEFT PUSH: *Not used.*

RIGHT PUSH: *Not used.*

6

Operation Head Mode, Right Joystick

TOP LEFT FRONT BUTTON: Toggles between sides in Networks

TOP RIGHT FRONT BUTTON: Enables/disables Conveyor.

FOUR-WAY SWITCH UP: Manually runs the conveyor.

FOUR-WAY SWITCH DOWN: *Not used.*

FOUR-WAY SWITCH RIGHT: Move the blade guide in.

FOUR-WAY SWITCH LEFT: Move the blade guide out.

BOTTOM FRONT BUTTON: Initiates a bump up function.

REAR SWITCH: Initiates a set function.

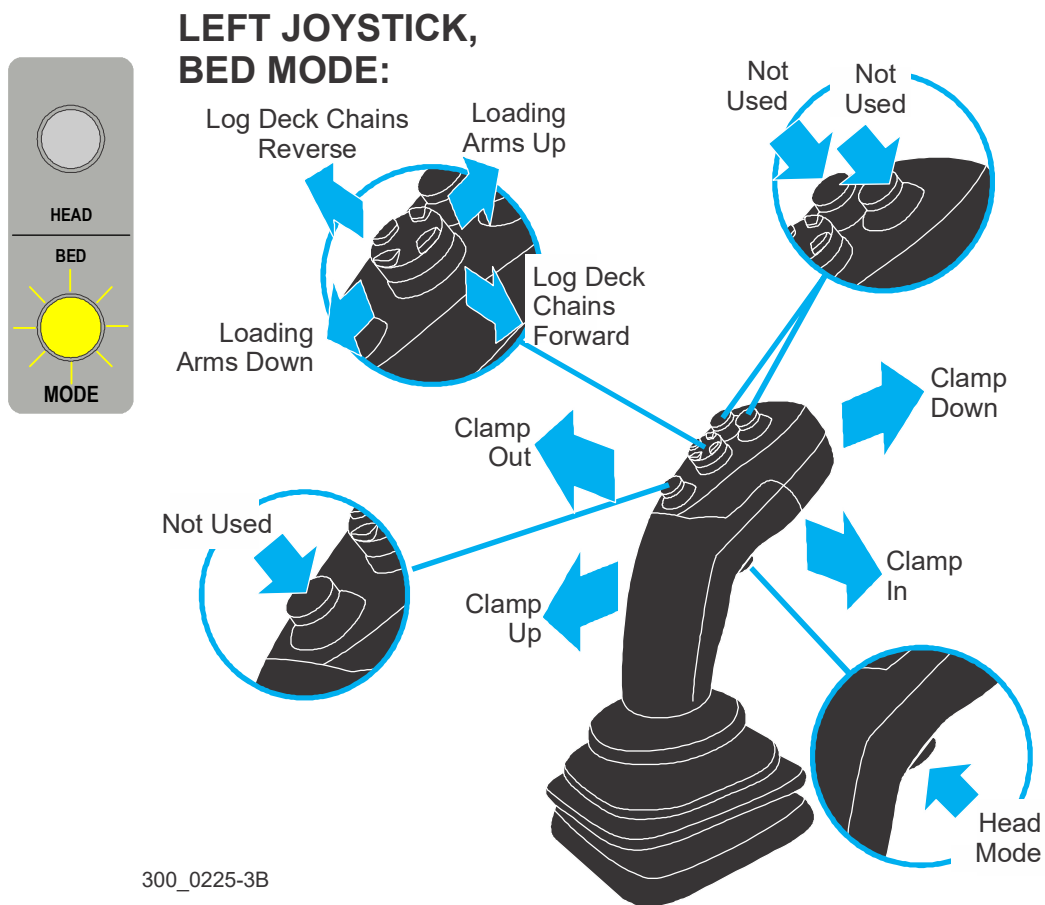

FIG. 6-6

FORWARD PUSH: Lowers the clamp.

BACKWARD PULL: Raise the clamp.

LEFT PUSH: Moves the clamp out.

RIGHT PUSH: Moves the clamp in.

TOP LEFT FRONT BUTTON: *Not used.*

TOP RIGHT FRONT BUTTON: *Not used.*

FOUR-WAY SWITCH UP: Raised the loading arms.

FOUR-WAY SWITCH DOWN: Lowers the loading arms.

FOUR-WAY SWITCH RIGHT: Moves the log deck chains forward.

FOUR-WAY SWITCH LEFT: Moves the log deck chains backward.

BOTTOM FRONT BUTTON: *Not used.*

REAR SWITCH: Toggles to Head Mode.

Bed Mode: Right Joystick

FIG. 6-7

FORWARD PUSH: Lowers the side supports.
The further the joystick is pushed, the faster the side supports lower.

BACKWARD PULL: Raises the side supports.
The further the joystick is pulled, the faster the side supports raise.

LEFT PUSH: Lowers the chain turners.

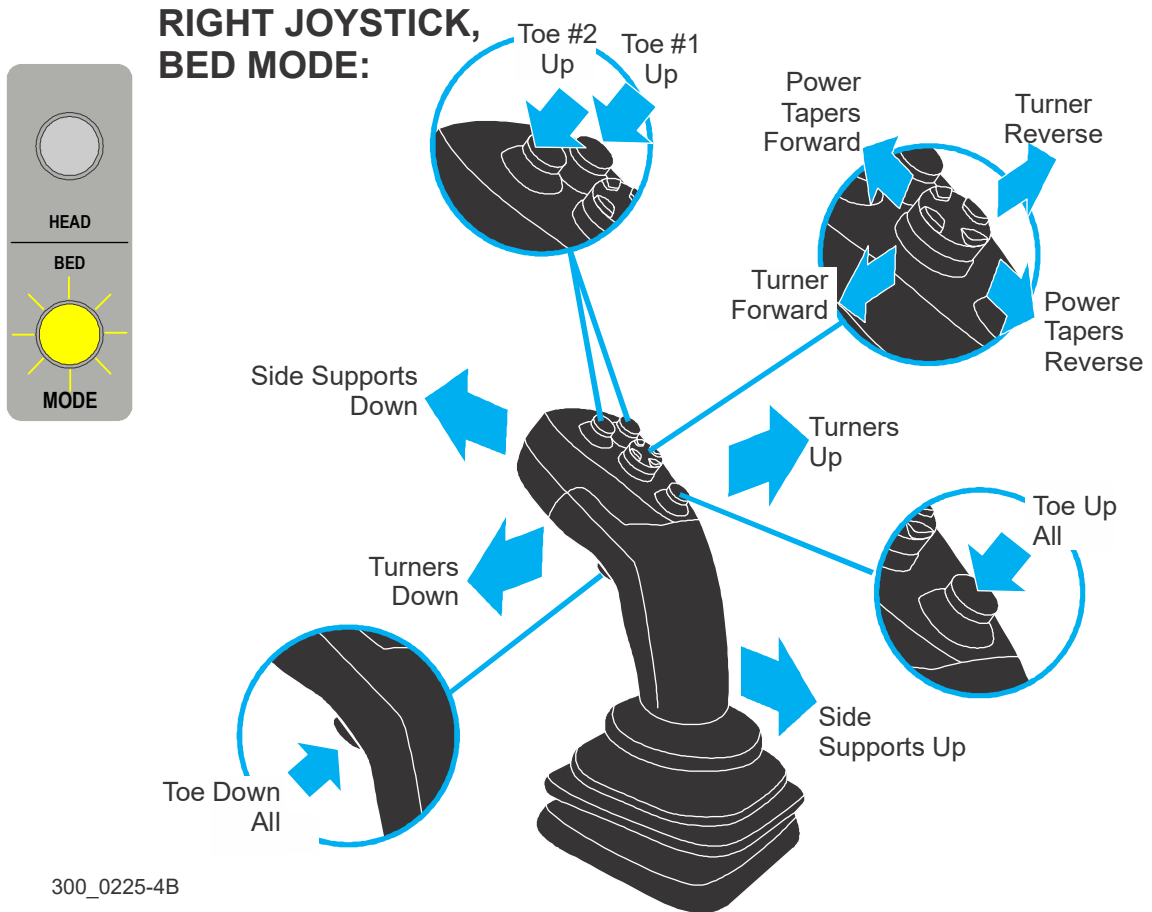
RIGHT PUSH: Raises the chain turners.

TOP LEFT FRONT BUTTON: Raises toe board #2.

TOP RIGHT FRONT BUTTON: Raises toe board #1.

FOUR-WAY SWITCH UP: Moves the power taper rollers forward.

FOUR-WAY SWITCH DOWN: Moves the power taper rollers backwards.

FOUR-WAY SWITCH LEFT: Rotates the chain turners forward.

FOUR-WAY SWITCH RIGHT: Rotates the chain turners backwards.

BOTTOM FRONT BUTTON: Raises both toe boards.

REAR SWITCH: Lowers both toe boards.

6 Operation

Programming the Control

6.4 Programming the Control

System Setup

1. Press the **Setup** button on the Main Screen..



FIG. 6-7



FIG. 6-7

OPTIONS

There are several optional functions built into the mill to help automate some of the steps for sawing a log. These steps were developed around the most common cutting method.

Typically the method followed is to open two sides in reference mode. Switch to pattern mode and cut down to the desired number of cants with the dimensions selected.

Pattern Mode Trim Cut Position - Pattern mode allows the operator to select the position of the trim cut; opening cut, before the first cant, or last board.

Return To Reference Automatically When Starting A New Log - The touch screen will automatically switch back to reference mode each time a new log is started by

- performing a staging function
- lowering the loading arms all the way

Default Back To Board Dim 1 When Starting A New Log - The board size in the first board size button, from left to right, will be selected each time a new log is started. There are two ways to signal the start of a new log;

- performing a staging function
- lowering the loading arms all the way.

Automatically Switch Sides With Log Turns - The machine will automatically switch sides, i.e. **Reference 1 to Reference 2**, when the log is unclamped when any one-of-four chain turner functions activated; Up/Down or Forward/Reverse.

NOTE: The machine will not keep changing sides each time one of these functions is activated. There must be a cut taken on the side switched to before the machine will switch again.

180 Degree Log Turns with Pattern Mode - When a log is turned the machine will assume the log is flipped 180 degrees and automatically goes to Pattern 1.

Go to Pattern Automatically After Opening 2nd Side In Reference - After a log turn is sensed, the touch screen will automatically switch to Pattern mode after a cut has been taken in Reference 2.

NOTE: This option is not available unless the option to Automatically Switch Sides With Log Turns is enabled.

Use Reference Position To Calculate Pattern Positions - When the trim cut position is set to Open Cut, the last cut taken in Reference 1 will be used as a Reference Position for the head to calculate the Pattern based off the cant size s, number of cants, and board size selected. This prevents having to search for best position for possible opening cut.

When the trim cut position is set to **first cant/last board**, the last cut taken in Reference 1 will be used as the last cut taken in Pattern 1 and just set to the next board size. Reference 2 last cut position will be used for Pattern 2.

180 Degree Log Turns with Stack Mode - When the log is turned the machine will assume the log is flipped 180 degrees and automatically goes to Stack 1.

Go to Stack Automatically After Opening 2nd Side In Reference - The touch screen will automatically switch to Stack mode after a cut has been taken in Reference 2 and a log turn is sensed. This option is not available unless the option to Automatically Switch Sides With Log Turns is enabled.

Use Reference Position To Calculate Stack Positions - The last cut taken in Reference 1 will be used as a reference position for calculating the starting position for the head in stack mode in the stack. Reference 2 last cut position will be used for Stack 2.

Automatic Next Cut - Next Cut will automatically turn on when taking the opening cut on all four sides when the machine senses a cut is active based on the blade motor power engage threshold setting.

Automatic Return to Start of Log - After the head has exited the cut, It will perform a bump up, and automatically return to the position set for Start of Log. The operator does not need to let off the joystick in time to stop the head, just keep the joystick pressed all the way forward until the head comes to a complete stop.

Use SOL Speed For Set Distance, 2ft (0.6m) - The start of log speed set on the Dashboard will only be used for a distance of 2ft (0.6m) from the point where it was set. Once the head has moved past this point, the speed is completely controlled by the position of the joystick.

Loading Arm Auto Up - pressing and releasing the loader up button will move the loader up for a preset time period. When disabled it is necessary to hold the loader up button in order to raise the loader all the way.

Continued Button - Use this button to go the second page of options. Second page of option is shown below.

UNITS

- Imperial Fractions (ex. 1-1/2")

- Imperial Decimals (ex. 1.5")
- Metric (ex. 37mm)

The active unit has a green indicator. To change units, press the desired button and the indicator for that unit will turn green.

HOUR METERS

PERMANENT. Meter is not resettable

TEMPORARY. Meter can be reset by pressing the numeric display.

NOTE: If the PLC is replaced, the permanent hour meter will reset to 0.

Options 2 screen

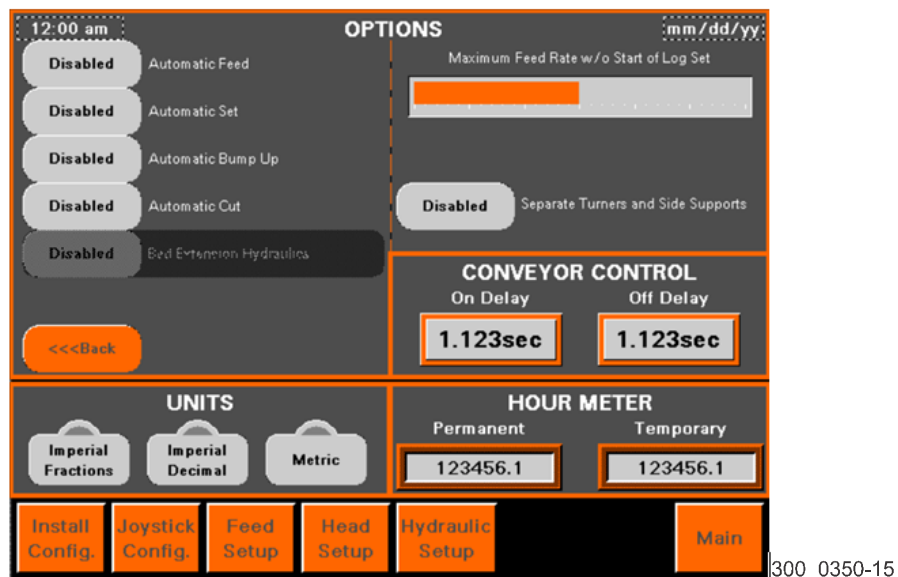

FIG. 6-8

OPTIONS

Automatic Feed - The feed speed is automatically controlled based on the, maximum speed and maximum power, settings on the Dashboard. The operator still has control over the speed, the automatic feed will just prevent them from feeding too fast, per the maximum power setting.

NOTE: If the maximum speed is reached before the maximum power the feed will not increase anymore, otherwise it will continue to increase until it reaches the maximum power setting.

Example: If the operator reduces joystick pressure the machine will choose the lower speed and use that.

Automatic Set - The head will automatically set to the next cut when the head has returned to the Start of Log position.

Automatic Bump Up - The saw head will automatically bump up after the saw head has exited to cut and passed the End of Log position.

Automatic Cut - The machine can run the cutting process automatically when the operator holds down the foot pedal.

- 1). Begin the automatic cut by setting the Start of Log and End of Log positions.
- 2). Make the cut, then hold down the foot pedal when at the Start of Log or End of Log positions.

NOTE: The head will automatically cut using the Automatic Feed, Bump Up, Return, and Set, all on its own, and continue this process until the foot pedal is released.

Bed Extension Hydraulics - The hydraulics on the bed extension will be active and work with the hydraulics of the standard bed.

NOTE: This option is not available when the Bed Extension has not been turned on in the Installation Configuration.

Back Button - Use this button to go back to the first page of options.

Maximum Feed Rate w/o Start of Log Set - This sets the maximum forward feed rate when Start of Log is active allowing the head to move up to 300ft/min forward.

On Delay - This timer sets how long the feed must be in reverse before the conveyor will start.

Off Delay - This timer sets how long the conveyor will keep running after the feed has stopped moving in reverse.

Joystick Configuration

The machine is equipped with one default and two programmable joystick configurations. During the installation of the machine, it may be necessary to configure some of the parameters of the joysticks.

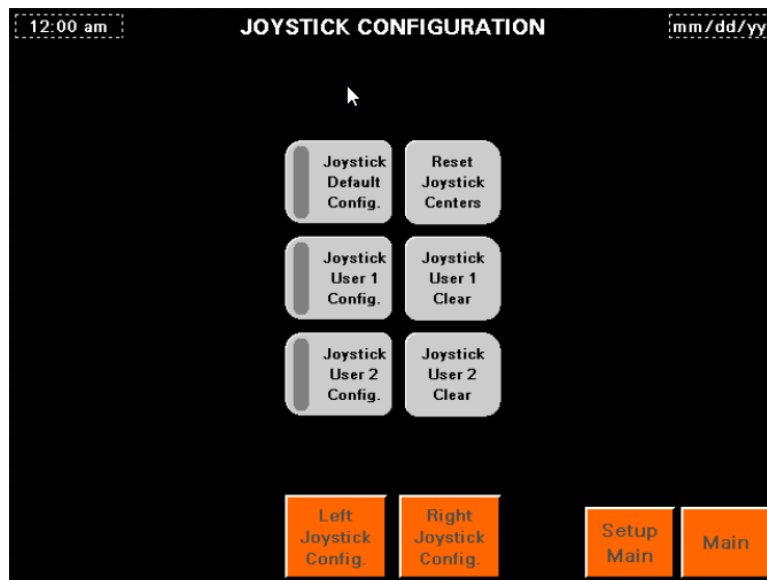

300_0350-19

FIG. 6-9

Reset Joystick Centers - It is critical for correct machine operation that the joysticks are centered. In the case that the centers need set a Joystick Configuration error will flash. During the very first power up of the machine, replacement of a joystick, or replacement of the PLC, the centers of the joysticks will have to be set.

To reset centers:

- 1). From the System Setup Screen, press the Joystick Configuration button to go to the Joystick Configuration screen.
- 2). Make sure the joysticks are in their relaxed position with nothing pushing them in any direction.
- 3). Press the reset joystick centers button

When the centers are captured the PLC will configure a dead band area around the centers that has to be exceeded to make the joystick control any motion.

Joystick Default Config. - Selects the default layout of all the joystick functions. When the default configuration is active, the indicator on the button will be green.

NOTICE Customer service uses default configurations when conducting troubleshooting or instructions. Custom user configurations are not recommended, but are available if necessary.

User Defined Joystick Configurations - Control the user defined joystick configurations.

- A. Joystick User 1 Config.** - Selects the user 1 configuration. When the user 1 configuration is active the indicator on the button will be green.
- B. Joystick User 1 Clear** - Clears the user 1 configuration from memory.
- C. Joystick User 2 Config.** - Selects the user 2 configuration. When the user 2 configuration is active the indicator on the button will be green.
- D. Joystick User 2 Clear** - Clears the user 2 configuration from memory.

Feed Setup

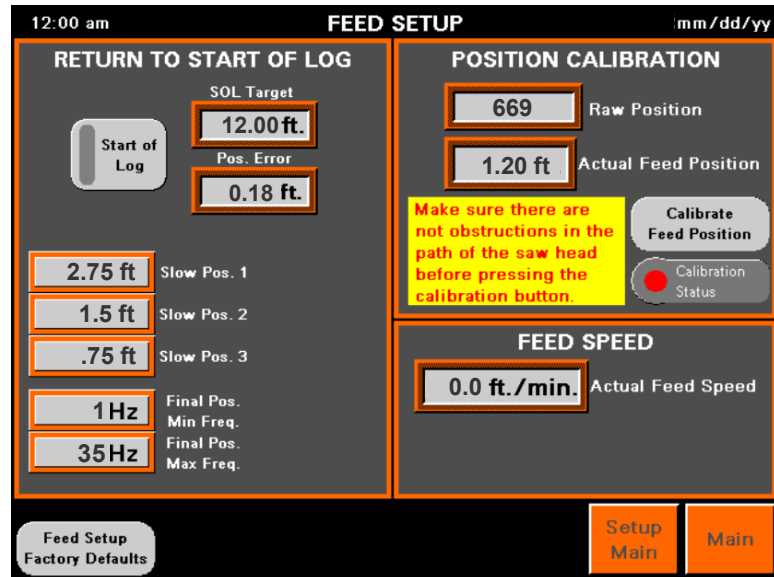

300_0349-2

FIG. 6-10

RETURN TO START OF LOG

When tuning the Return To Start of Log function try to get the Pos. Error to be as small as possible, meaning that it is as close as possible to the target you are trying to reach.

There are three positions captured for the Start of Log Position;

- **ACTUAL START OF LOG POSITION:** The actual Start of Log Position is the a position captured by pressing the button either on the touch screen or joystick. This position signals the machine that the head has moved into a safe position behind the log and it is okay to perform a set.
- **OFFSET:** The position the feed will stop at when feeding forward until it is in position for the next cut.
- **TARGET:** The position the feed system is shooting for during the return.

During the return, after the head has passed the Start of Log Position a set will initiate. The feed will continue returning to the Target and then stop. Now feed forward, the head may stop at the Offset position, if the head is not in position for the next cut. If the head is in position, there will not be a stop, it will continue to feed forward and start the cut.

FEED SETUP FACTORY DEFAULTS. Sets all the Feed Setup values back to factory defaults.

TUNING RETURN TO START OF LOG

1. Move the head to desired Start of Log position and press the Start of Log button. The indicator will turn green to show that the position has been set, and the position will display under SOL Target.
2. Now run the feed about 12 ft. from that position.
3. Push the Right joystick forward and maintain it until the head comes to a complete stop.
4. Check the Pos. Error. If it is within a couple inches from the target leave it alone, the tuning is fine. The control for returning to start of log is not designed to be extremely accurate, so a couple inch tolerance is fine. Process is complete. If the Pos. Error is too large then continue to step 5.
5. Modify the Slow Positions and Final Pos. frequencies, until the desired accuracy is achieved.
 - **SLOW POS. 1** - Default = 2.75. The distance from Start of Log Target at which the feed drive will slow to 60Hz. Prior to reaching this point the feed will travel in reverse at maximum speed.
 - **SLOW POS. 2** - Default = 1.5. The distance from Start of Log Target at which the feed drive will slow to the Final Pos. Max Freq.
 - **SLOW POS. 3** - Default = 0.75. The distance from Start of Log Target at which the feed drive will ramp from the Final Pos. Max Freq., to the Final Pos. Min Freq.

The deceleration of the drive is proportional to the distance from Slow Pos. 3 to SOL Target. The drive will begin at the frequency in Final Pos. Max Freq. at Slow Pos. 3 and do a linear slope to the frequency in Final Pos. Min Freq. at SOL Target.

- **FINAL POS. MIN FREQ.** - Default = 1.
- **FINAL POS. MAX FREQ.** - Default = 35.

FEED SETUP FACTORY DEFAULTS. Returns setting on the Feed Setup screen to the factory default settings.

POSITION CALIBRATION

- **RAW POSITION.** Displays the raw data from the encoder before it is converted to the actual units.
- **ACTUAL FEED POSITION.** The position at which the head is pressing against a hard stop.
- **CALIBRATE FEED POSITION.** Initiates a calibration procedure.
- **CALIBRATION STATUS.** Displays red when a feed position calibration is required; displays green for routine calibration.

FEED SPEED

- **ACTUAL FEED SPEED.** Displays the actual feed speed.

Position Calibration Procedure

If the machine needs to be calibrated, the control display will automatically switch to the Feed Setup screen after control power is turned on. The only time this is not the first screen displayed after a power cycle is if there is a Joystick Configuration fault and the Centers of each joystick need to be reset and the furthest travel positions need to be captured. Usually this only happens during the initial install of the machine, and never again unless the PLC gets replaced. If the Feed Setup screen is already active then proceed to step 3.

At the top right of the Feed Setup screen is the Position Calibration section. If calibration is required then the Calibration Status will be RED; if just re-calibrating then it is GREEN.

Make sure there are no obstructions in the path of the saw head. The head will travel all the way to the reverse hard stop.

Press the Calibrate Feed Position button.

The head will start slowly traveling to the reverse hard stop. To calibrate the feed position the head presses against the hard stop until there is a spike in motor current on the feed motor. At that point that position is called 1' 0", and the Actual Feed Position should have a value around 1.0ft., the value sometimes floats above this because when the feed drive release pressure the rubber stop pushes the head back away from it. The Calibration Status light will turn green when the process is complete.

Head Setup

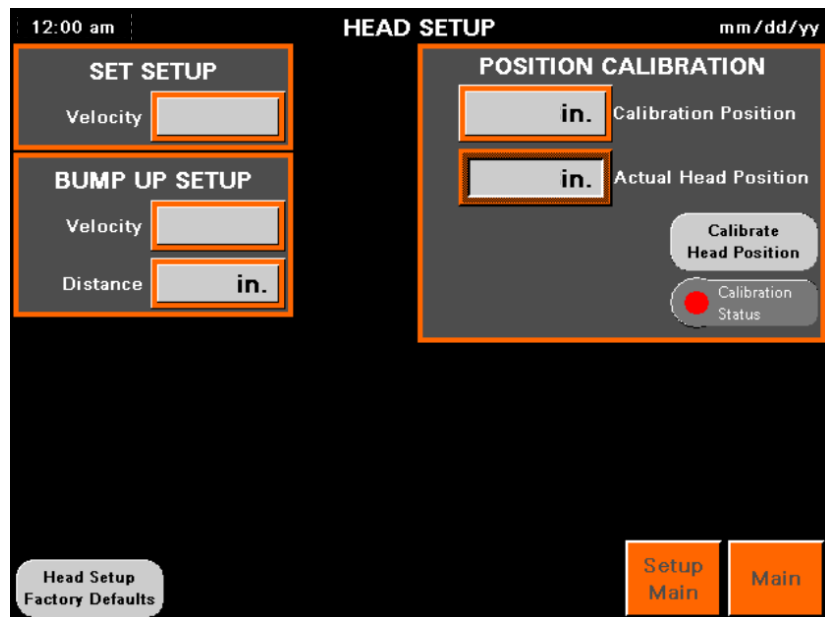

300_0349-3

FIG. 6-11

The Head Setup screen set speed and calibrates the head position.

SET SETUP

- **VELOCITY:** Sets speed for sets.

BUMP UP SETUP

- **VELOCITY:** Sets speed for bump ups.
- **DISTANCE:** Sets distance for bump ups.

HEAD SETUP FACTORY DEFAULTS: Resets all the values back to factory defaults.

- **CALIBRATION POSITION:** Sets the position measured from a down set tooth to the bed rail and entered here.
- **ACTUAL HEAD POSITION:** Indicates head position.
- **CALIBRATE HEAD POSITION:** Runs calibration sequence.
- **CALIBRATION STATUS:** Red when calibration is necessary; green when good.

Position Calibration Procedure

If the machine needs calibrated, the control display will automatically switch to the Head Setup screen after control power is turned on. If the Head Setup screen is already active then proceed to Step 3.

1. At the top right of the Head Setup screen is the Position Calibration section. If the calibration is required then the Calibration Status will be RED, if just re-calibrating then it is probably GREEN.
2. Position the head over a bed rail and measure from a down set tooth to the bed rail.
3. Enter this value in the Calibration Position numeric entry box.
4. Press the Calibrate Head Position button.
5. Calibration complete.

Hydraulic Setup

The hydraulic power unit on this machine is equipped with a proportional valve on the supply line to all the valve packs. Since only 8 functions can be assigned to the joystick bases for full proportional control, a setup screen for all functions has been added so that a set-point for flow to each function can be set from 5-100%. If multiple functions are selected with set-points then that proportional valve will open fully to give sufficient flow. If a proportional function is used with a discrete function the proportional valve will use the

proportional signal. If multiple proportional functions are activated then the proportional valve will open fully to give sufficient flow.

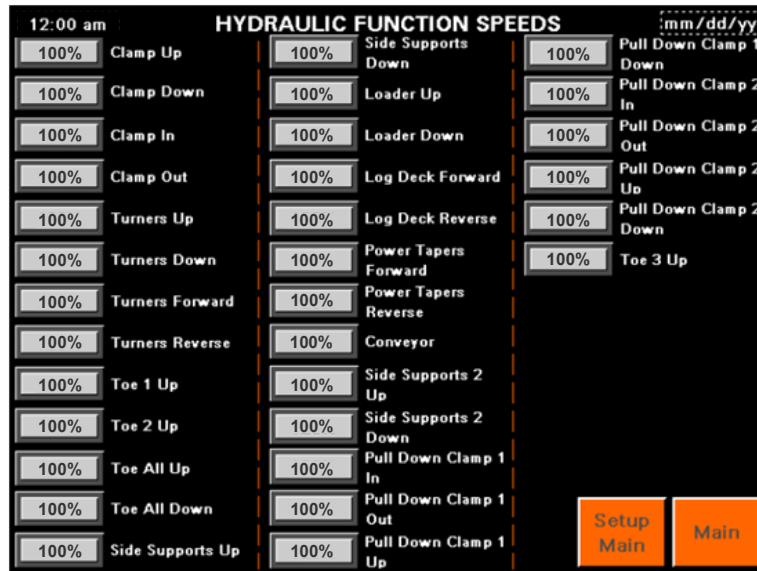

300-0350-18

FIG. 6-12

Changing Hydraulic Set-Points

To modify one of the hydraulic set-points:

- 1). Press the number display for the desired function to change.
- 2). Enter the new value and press Enter.

Networks Setup

See [Section 4.4 Initial Sawmill Setup](#) for the complete Networks setup information.

Bed Extension Setup (Optional)

Perform the following control setup steps to start using an optional bed extension:

1). From the Main screen, press the Setup button to enter the Options screen.

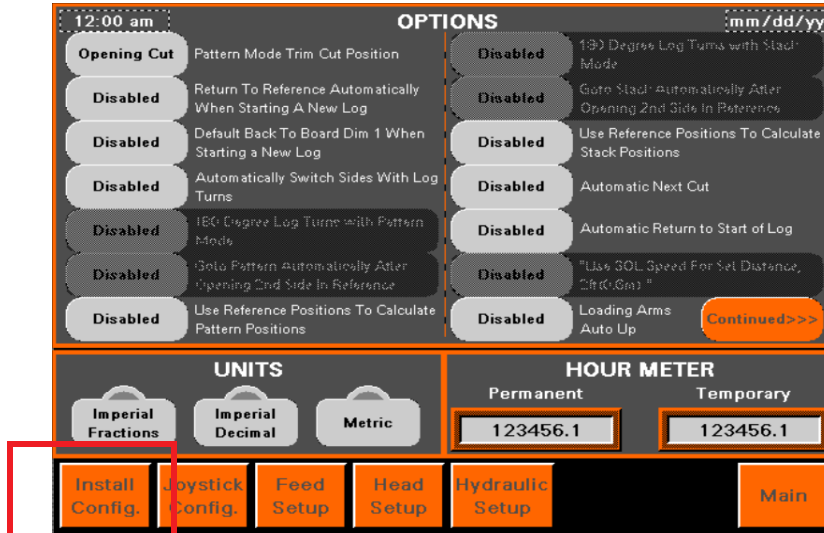
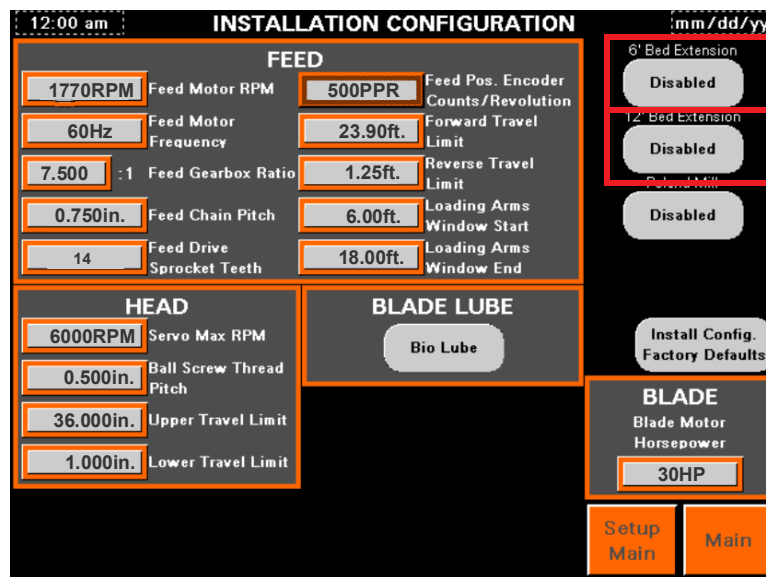

FIG. 6-13

2). Press the Install Config. button on the Options screen to enter the Installation Configuration screen.

3). Press the button for the corresponding bed extension option that was installed.



300_0350-16

FIG. 6-14

6 Operation

Bed Extension Setup (Optional)

6.5 Starting the Controls



DANGER! Make sure all guards and covers are in place and secured before operating the sawmill. Failure to follow this may result in serious injury.



DANGER! Always be sure all persons are out of the path of the blade before starting the motor. Failure to follow this will result in serious injury.



WARNING! Always wear eye, ear, respiration, and foot protection when operating the sawmill. Failure to follow this may result in serious injury.

1. Release the EMERGENCY STOP button by turning it clockwise until it pops out.

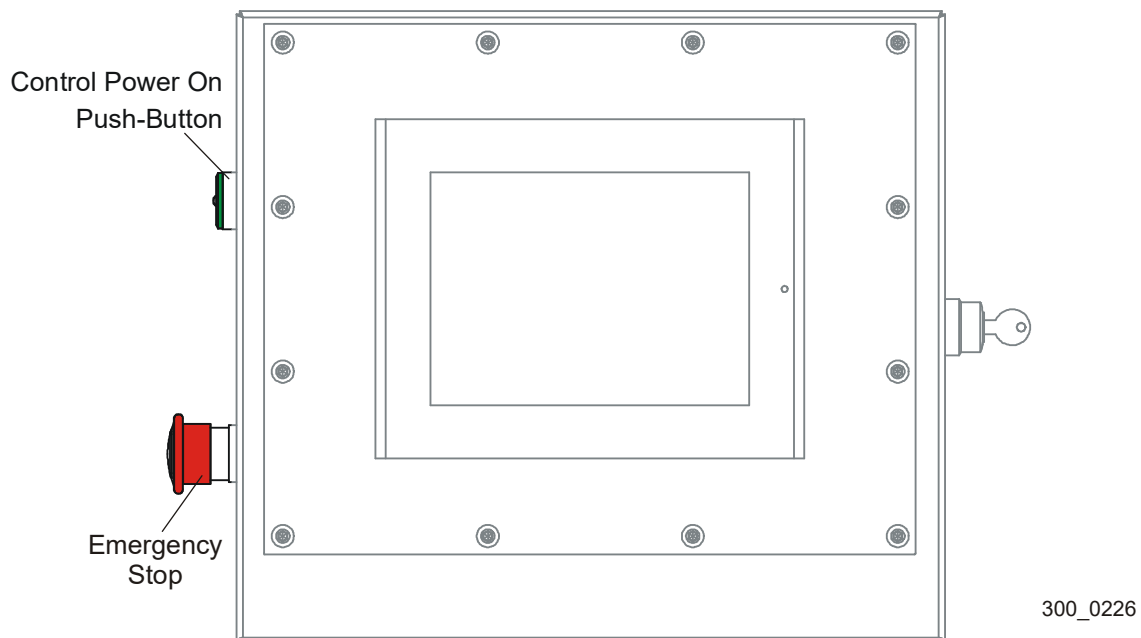

FIG. 6-15

2. Push the green Power On button on the control box to turn on the sawmill power.

6.6 Installing A Blade



DANGER! Shut off the sawmill and wait until the blade wheels have come to a complete stop before changing the blade. Failure to follow this will result in serious injury.



WARNING! Turn the key switch to OFF and remove the key before changing the blade. Failure to follow this may result in serious injury.



WARNING! Wear gloves and eye protection when handling bandsaw blades. Changing blades is safest when done by one person! Keep all other persons away from area when coiling, carrying or changing a blade. Failure to follow this may result in serious injury.



WARNING! DO NOT use blades with stress cracks. Blades with stress cracks can shatter causing bodily injury and/or machine damage. Failure to follow this may result in serious injury.

1. At the operator station control box, turn the key switch to OFF and remove the key.

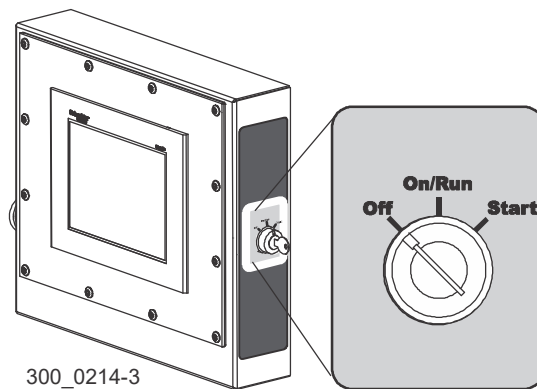

FIG. 6-15

2. At the saw head distribution box, push the BLADE TENSION button in to release the blade tension.

3. Unscrew and pivot the cover locks to open the blade housing covers.

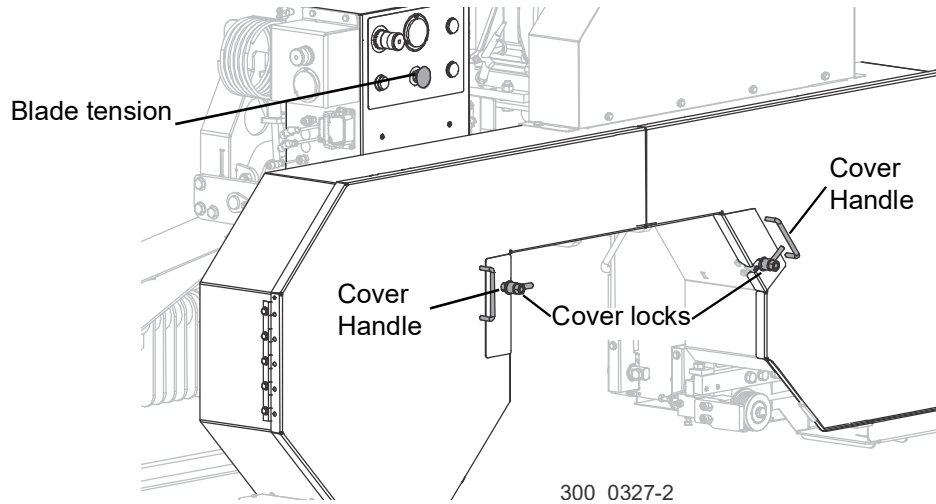

FIG. 6-16

4. Remove the blade, as necessary.
5. Install the blade around both blade wheels and between the blade guides.

NOTICE Ensure the teeth are pointing the correct direction. The teeth on the portion of the blade between the blade guides should be pointing toward the motor side of the sawmill.

6

Operation Installing A Blade

6. Position the blade on the wheels so the gullet is even with the front edge of the wheel (+1/16", -0).

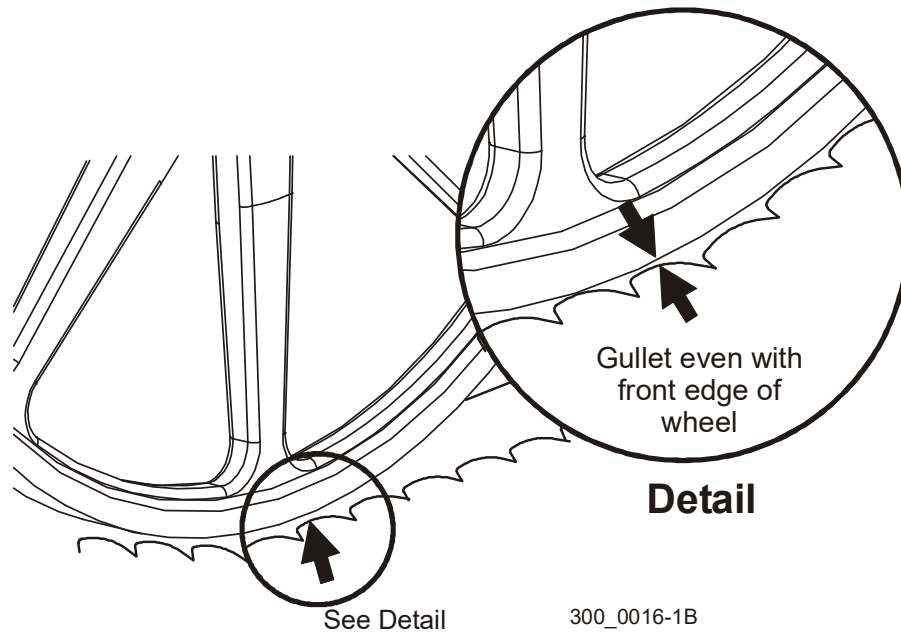

FIG. 6-17

7. Pull the BLADE TENSION button.

The TENSION PRESSURE gauge should read 60 psi for 1 1/4" blades, 80 psi for 1 1/2" blades, or 100 psi for 1 3/4" blades.

8. Adjust the blade tension pressure with the TENSION REGULATOR knob.
9. Push the BLADE TENSION button to release the blade tension.
10. Turn the TENSION REGULATOR knob counterclockwise to reduce blade tension, clockwise to increase blade tension.
11. Pull the BLADE TENSION button to re-tension the blade.
12. Close the blade housing covers and secure with the lock handles.



WARNING! Make sure all persons are clear of the saw head. Failure to follow this could result in serious injury or death.

13. At the operator station control box, insert the key and turn the key switch to the START position and release, leaving the key switch in the ON/RUN position.

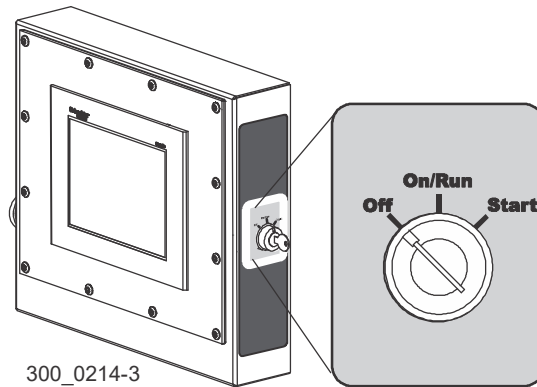

FIG. 6-17

14. Let the motor spin the blade for a few seconds, turn the key switch to OFF and remove the key.



WARNING! Do not spin the blade wheels by hand. Failure to follow this could result in serious injury or death.

15. Open the blade housing covers and recheck that the blade has maintained the proper position on the blade wheels as described above.
16. If adjustment is needed, push the BLADE TENSION button to release the blade tension.

17. Loosen the jam nuts on the side adjustment bolts located at the end of the blade wheel shaft housing.

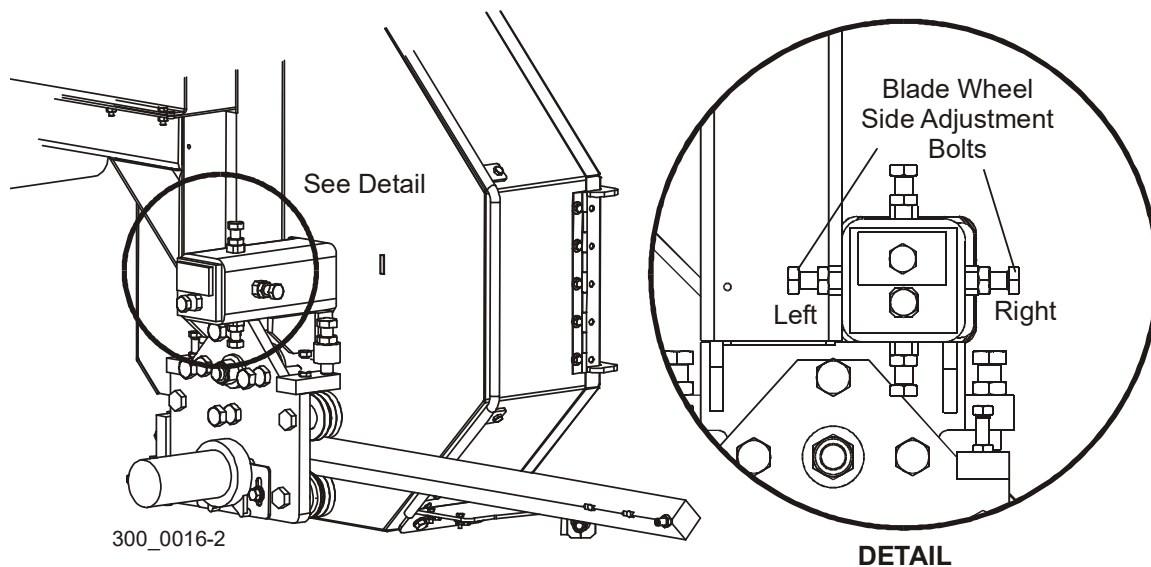
**FIG. 6-18**

18. Move the blade **out** on the blade wheel by loosening the right bolt and tightening the left bolt.

19. Move the blade **in** on the blade wheel, loosen the left bolt and tighten the right bolt.

NOTE: Slight adjustments of the side bolts on the outer blade wheel are usually all that is necessary to track the blade properly. [See Section 7.2](#) for complete blade wheel alignment instructions.

20. Tighten the side adjustment bolt jam nuts, close the blade housing covers, and re-tension the blade.

21. Repeat steps 14 through 20 until the blade tracks on the blade wheels properly.

6.7 Loading, Turning And Clamping Logs

 **DANGER!** Keep all persons out of the path of moving equipment and logs when operating sawmill or loading and turning logs. Failure to do so will result in serious injury.

 **CAUTION!** Before loading a log, be sure the cutting head is moved far enough back so the log does not hit it. Failure to do so may result in machine damage.

 **CAUTION!** Be sure the log clamp, turning arm and rollers are adjusted out of the path of the log before loading a log onto the bed. Failure to do so may result in machine damage or cause misalignment.

1. Ensure the joysticks are in Head Mode.
2. Raise the saw head to clear any obstructions (left joystick backwards).
3. Move the head to the reverse hard stop (right joystick forward).

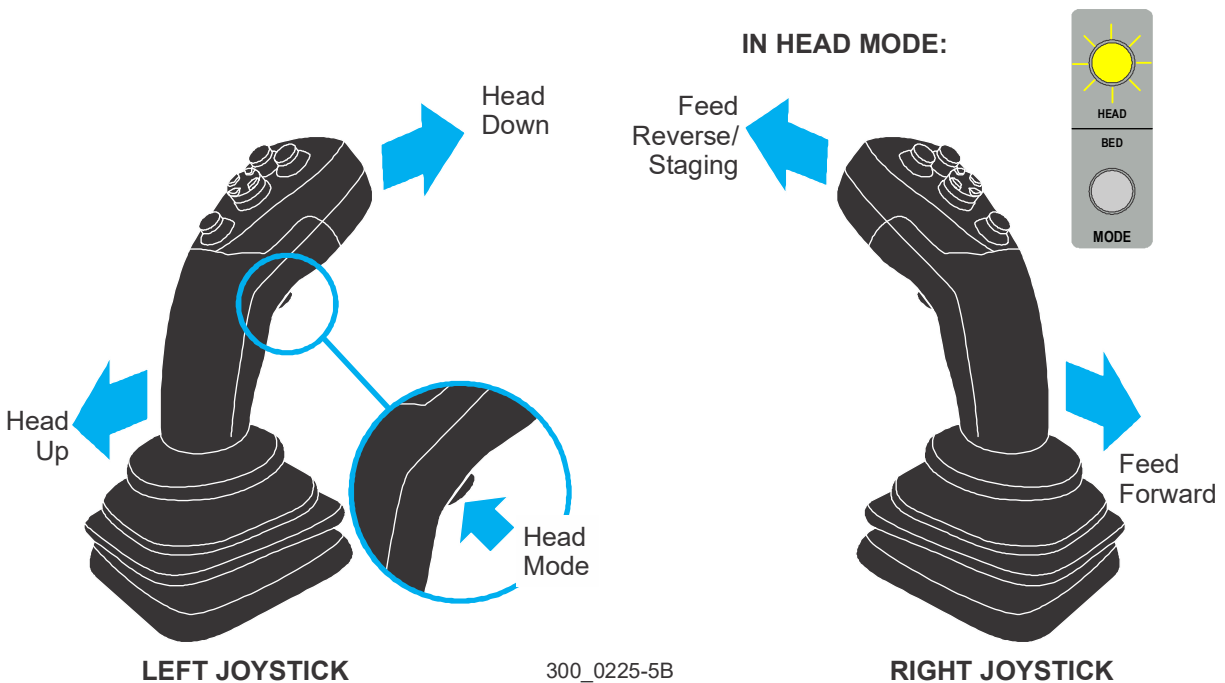

FIG. 6-19

6

Operation

Loading, Turning And Clamping Logs

- Put the mill in BED Mode (left joystick, rear switch button).

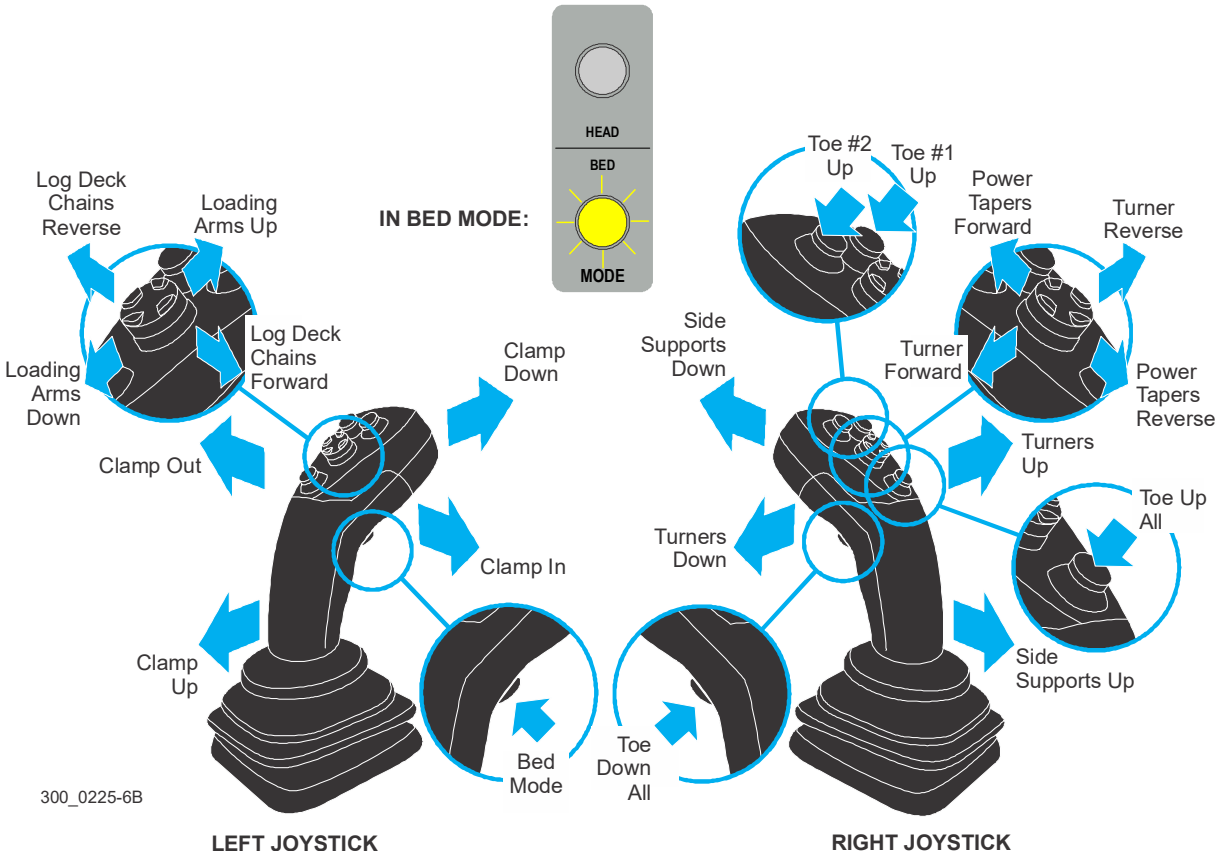

FIG. 6-20

- Raise the side supports fully up (right joystick, backward).
- Move the clamp completely out (left joystick, left).
- Lower the clamp completely down (left joystick, forward).
- Lower the toe boards (right joystick, rear switch button).
- Lower the turners completely down (right joystick, left).
- Run the log deck chains forward until a log is against the loading arms (left joystick, 4-way switch right).
- Lower the loading arms until the log rolls onto the bed (left joystick, 4-way switch down).



DANGER! Keep all persons out of the path of moving equipment and logs when operating sawmill or loading and turning logs. Failure to do so will result in serious injury.

12. Raise the clamp (left joystick, backwards).
13. Bring the clamp in to keep the log from rolling back to the loading arms (left joystick, right).
14. Raise the loading arms fully up (left joystick, 4-way switch up).
15. Raise the turners (right joystick, right).
16. Spin the log by turning the turner chains forward or backward (right joystick, 4-way switch left or left).
17. Lower the turners (right joystick left).
18. Lower the side supports enough to ensure you will not hit them when cutting (right joystick, forward).
19. Taper the log with the toe board as necessary (right joystick, right head button for toe board 1, left head button for toe board 2).
20. Adjust the clamp up or down as needed (left joystick, forward/downward).
21. Clamp the log completely (left joystick, right).
22. Put the mill in HEAD Mode (left joystick, rear switch button).

6.8 General Sawing Sequence



DANGER! Keep all persons out of the path of moving equipment and logs when operating sawmill or loading and turning logs. Failure to do so will result in serious injury.

NOTE: For this sequence the Trim Cut is set to default, Opening Cut, all options are disabled, and the joysticks are in the default configuration.

Prepare the sawmill

1. Turn on control power:
 - Release the e-stop button by twisting it clockwise until it pops out.
 - Press the control power on button and release it; button lights green and stays on.
 - Wait for the Power Up pop up window to disappear.
2. Start the blade by turning the key switch on the control box clockwise to the START position and release.
3. Load a log. [See Section 6.7.](#)

Make the opening cut on the first side

1. Ensure the joysticks are in Head Mode.
2. From the Networks main screen, tap the Networks Main button to enter Manual Mode.
3. Tap the Reference Mode button.
4. Move the sawhead near the start of the log (right joystick backward).
5. Position the height the saw head for your opening cut (left joystick forward or backward).
6. Capture the Start of Log position (left joystick, the left head button).
7. Turn on Next Cut to capture the current saw head position for Reference 1 (left joystick, right head button).
8. Start sawing (right joystick backward).

- Saw head speed is set on the Dashboard screen.
 - Once the blade power reaches the Cut Engage HP set on the Dashboard, the operator has full control of the feed speed from the joystick. The farther it is pulled back, the faster it will feed. Monitor blade power while pulling the joystick back.
9. Capture the End of Log position when the blade completely exits the log (left joystick, the left head button).
 10. Stop the saw head when the fingers clear the log (joystick to neutral).
 - If the slab is large enough to push back with the fingers, do a bump up (right joystick, bottom head button).
 - If the slab is too thin to push back, lift the saw head over (left joystick backward).
 11. Return to the start of log (right joystick backward).
 - Ease up on the joystick to slow down when nearing the start of log.
 12. Check the board size on the Reference Mode screen, then perform a set (right joystick, rear switch button).
 13. Saw another board with the same sequence of steps 8-11, skipping step 9.

Turn the log to side 2

1. Return the saw head to the start of log position
2. Switch to bed mode (left joystick, rear button).
3. Unclamp the log (left joystick, left).
4. Lower any toe boards (right joystick, rear button).
5. Raise the side supports completely up (right joystick, backward).
6. Raise the turners (right joystick, right).
7. Turn the log with the turner chains until the flat face is against the side supports, (right joystick, 4-way switch left).
8. Lower the turners by pulling the (right joystick, left).

6

Operation

Make the opening cut on the second side

9. Lower the side supports enough to ensure you will not hit them when cutting.
10. Taper the log with the toe board as necessary (right joystick, right head button for toe board 1, left head button for toe board 2).
11. Clamp the log (left joystick, right).
 - Support the log with the turners when clamping to keep the flat against the side supports as necessary.
 - Raise and lower the clamp to tap the flat back against the side supports (left joystick, forward/backward).

Make the opening cut on the second side

1. Tap the Reference 2 button to activate the second side.
2. Position the saw head up/down for the opening cut.
3. Tap the Reference 2 button again, which sets the current position.
4. Tap the Next Cut button.
5. Make your opening cut using the sequence in [Section *Make the opening cut on the first side*](#), steps 8-11, skipping step 9.
6. Tap the Next Cut button for each successive cut until you are ready to turn the log again.
7. Turn the log placing side 2 against the side supports.

Make the opening cut on the third side

1. Tap the Pattern Mode button on the Reference Mode.
2. Check the selected board size.
 - Select the appropriate cant size, if cutting cants.
 - Set the correct number of cants for this size.
3. Move the saw head to the opening cut.
4. Tap the rear switch button on the right joystick to set to the nearest board based on the cant size, cant number, and board size selected.

5. After the saw head is in position, continue cutting with the same sequence as in [Section *Make the opening cut on the first side*](#), steps 8-11, skipping step 9.
6. Repeat the step above until you are ready to turn the log.
 - If you cut all the way down to your cants, once you reach the first one the next set will be the cant size, then you will have to turn the log to continue cutting.
7. Turn the log placing side 3 against the side supports.

Make the opening cut on the fourth side

1. Tap Pattern 2 to active the fourth side.
2. Check the board size.
 - Select the appropriate cant size if cutting cants.
 - Set the correct number of cants for this size.
3. Move the saw head to the opening cut.
4. Tap the rear switch button on the right joystick to set to the nearest board based on the cant size, cant number, and board size selected.
5. After the saw head is in position continue cutting with the same sequence as in [Section *Make the opening cut on the first side*](#), steps 8-11, skipping step 9.
6. Repeat the step above until you are ready to turn the log.
 - If you cut all the way down to your cants, once you reach the first one the next set will be the cant size, then you will have to turn the log to continue cutting.
 - If you turn back to side 3 you will need to tap Pattern 1 on the Pattern Mode screen to switch back to the 1st/3rd side or if you turn again to the 2nd/4th side.

Return to the staging position, if set

1. Return the saw head to the set feed position after making the last cut on the last side (right joystick, rear and bottom buttons together -- release joystick).

The saw head will return to the set feed position and raise to the set saw head position.

NOTICE Do not load another log and start over at this time.

2. Reset Networks by tapping the Reference Mode button.

6.9 Automated Sawing Sequence



DANGER! Keep all persons out of the path of moving equipment and logs when operating sawmill or loading and turning logs. Failure to do so will result in serious injury.

NOTE: For this sequence the Trim Cut is set to default, Opening Cut, all options are disabled and the joysticks are in the default configuration.

Prepare the sawmill for loading a log

1. Turn on control power.
 - Release the e-stop button on the operator control by twisting it clockwise until it pops out.
 - Press the control power on button and release it. It should light up green and stay on.
 - Wait for the control to power up by waiting for the Power Up pop up window to disappear.
2. From the Main Screen go to the Setup screen and enable the following options by tapping the button to the left of each option:
 - Return To Reference Automatically When Starting A New Log
 - Automatically Switch Sides With Log Turns
 - Goto Pattern Automatically After Opening 2nd Side In Reference
 - Default Back To Board Dim 1 When Starting A New Log
 - Use Reference Positions To Calculate Pattern Positions
 - Automatic Next Cut
 - Automatically Return to Start of Log
 - Use SOL Speed For Set Distance, 2ft(0.6m)
 - Automatic Feed

- Automatic Set
 - Automatic Bump Up
 - Automatic Cut
3. Start the blade by turning the key switch on the control box clockwise to the START position and release.
 4. Load a log. [See Section 6.7.](#)

Make the opening cut on the first side

1. Ensure the joysticks are in Head Mode.
2. From the Networks opening screen, tap the Networks Main button to enter Manual Mode.
3. Tap the Reference Mode button.
4. Move the sawhead near the start of the log (right joystick backward).
5. Position the height the saw head for your opening cut (left joystick forward or backward).
6. Capture the Start of Log position (left joystick, the left head button).
7. Turn on Next Cut to capture the current saw head position for Reference 1 (left joystick, right head button).
8. Start sawing (right joystick backward).
 - The saw blade will enter the log at the Start of Log speed set on the Dashboard.
 - Once the blade power exceeds the engage threshold set on the Dashboard, the Automatic Feed will take over using the settings on the Dashboard. Networks selects the slower of either the Automatic or the Joystick (manual) speed. If the operator backs the joystick to a slower speed than the Automatic then the feed will slow to that speed.
 - Once the Automatic Feed engages the machine automatically turns on Next Cut and uses the current saw head position for Reference 1.
9. Capture the End of Log position when the blade completely exits the log (left joystick, the left head button).

The saw head will then automatically bump up.

10. Stop the saw head when the fingers clear the log (joystick to neutral).
 - If the slab is too thin to push back, lift the saw head over (left joystick backward).
11. Return to the start of log (right joystick backward).
 - Once the joystick is pushed back, the machine takes over to return to the target start of log position. Do not let off the joystick until the saw head has come to a stop.
 - Once the saw head has passed the actual Start of Log position, the saw head will start a set while still returning to the target Start of Log position.
12. Saw another board with the same sequence of steps 8 to 11, skipping step 9.

Turn the log to side 2

1. Return the saw head to the start of log position
2. Switch to bed mode (left joystick, rear button).
3. Unclamp the log (left joystick, left).
4. Lower any toe boards (right joystick, rear button).
5. Raise the side supports completely up (right joystick, backward).
6. Raise the turners (right joystick, right).
7. Turn the log with the turner chains until the flat face is against the side supports, (right joystick, 4-way switch left).
8. Lower the turners (right joystick, left).
9. Lower the side supports enough to ensure you will not hit them when cutting.
10. Taper the log with the toe board as necessary (right joystick, right head button for toe board 1, left head button for toe board 2).
11. Clamp the log (left joystick, right).
 - Support the log with the turners when clamping to keep the flat against the side supports.

- Raise and lower the clamp to tap the flat back against the side supports (left joystick, forward/backward).

Make the opening cut on the second side

1. Position the height the saw head for your opening cut (left joystick forward or backward).
2. Make your opening cut using the sequence in [Section *Make the opening cut on the first side*](#), steps 8 to 11, skipping step 9.

The machine automatically sets Reference 2 and turns on Next Cut.

3. Repeat the step above until you are ready to turn the log again.
4. Turn the log placing side 2 against the side supports.

NOTE: When turning the machine will automatically switch to Pattern Mode.

Make the opening cut on the third side

1. Check the board size.
 - Select the appropriate cant size if cutting cants.
 - Set the correct number of cants for this size.
2. Set to the nearest board based on the cant size, cant number, and board size selected (right joystick, rear switch button).

The last cut of Reference 1 determines where to make the opening cut.

3. Continue cutting with the same sequence as in [Section *Make the opening cut on the first side*](#), steps 8 to 11, skipping step 9.
4. Repeat the step above until you are ready to turn the log again.
 - If you cut all the way down to your cants, once you reach the first one the next set will be the cant size, then you will have to turn the log to continue cutting.
5. Turn the log, placing side 3 against the side supports.

NOTE: The machine will automatically switch to Pattern 2.

6

Operation

Make the opening cut on the fourth side

Make the opening cut on the fourth side

1. Check the board size.
 - Select the appropriate cant size if cutting cants.
 - Set the correct number of cants for this size.
2. Set to the nearest board based on the cant size, cant number, and board size selected (right joystick, rear switch button).

The last cut of Reference 2 determines where to make the opening cut.

3. Continue cutting with the same sequence as in [Section *Make the opening cut on the first side*](#), steps 8 to 11, skipping step 9.
4. Repeat the step above until you are ready to turn the log.
 - If you cut all the way down to your cants, once you reach the first one the next set will be the cant size, then you will have to turn the log to continue cutting.

NOTE: When turning the log the Control will automatically switch sides.

Return to the staging position, if set.

1. Return the saw head to the set feed position after making the last cut on the last side (right joystick, rear and bottom buttons together -- release joystick).

The saw head will return to the set feed position and raise to the set saw head position.

NOTICE Do not load another log and start over at this time.

2. Reset Networks by tapping the Reference Mode button.

SECTION 7 MAINTENANCE



DANGER! Before performing service near moving parts such as blades, pulleys, motors, belts and chains, first turn the power off and lockout the system ([See Section 2.3](#)). Failure to follow this could result in serious injury or death.

See the [Maintenance Log](#) located after this section for a complete list of maintenance procedures and intervals. Keep track of machine maintenance by filling in the machine hours and the date you perform each procedure.



This symbol identifies the interval (hours of operation) at which each maintenance procedure should be performed. Procedures that should be performed as required are indicated by A/R”.

Refer to option and engine manuals for other maintenance procedures.

7.1 Blade Guides

1. Check the rollers for performance and wear every blade change.
2. Replace any rollers worn smooth, have become cone shaped, or will not spin freely.
3. Check the lube nozzles (2) for good flow.

Preventing sap buildup on the blade is critical when using the high-performance blade guide system. If the wood you are sawing leaves sap buildup on the blade, increase the amount of oil mixed with the lube water.

4. Adjust the blade support channel to 1/16" (1.5 mm) away from the blade by loosen the mounting bolts and adjust the channel as necessary.
5. Check the channel every blade change.

NOTE: Failing to maintain this adjustment will lead to early blade breakage.

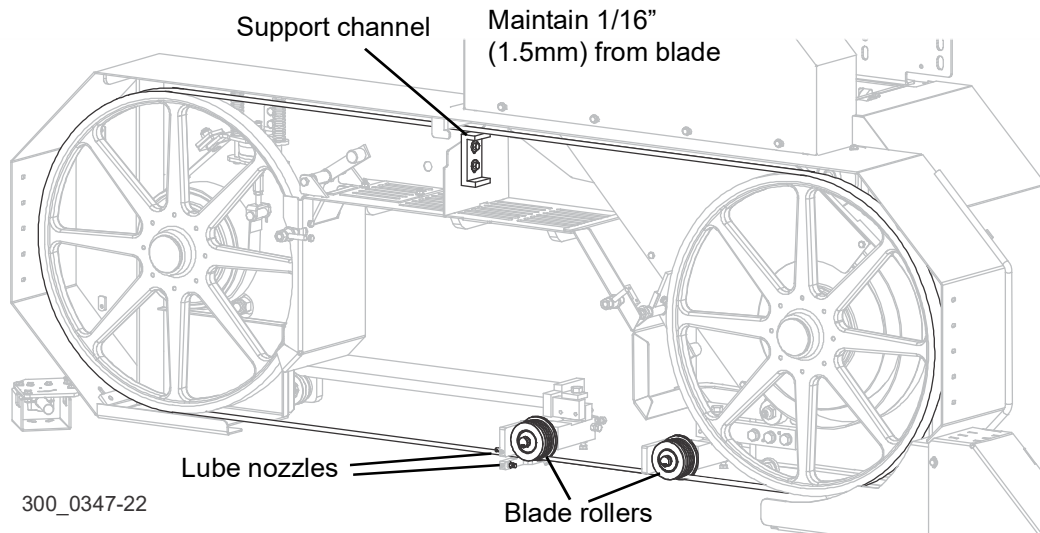

FIG. 7-1

7.2 Sawdust Removal



WARNING! Before performing service near moving parts such as blades, pulleys, motors, belts and chains, first turn the power off and lockout the system ([See Section 2.3](#)). Failure to follow this could result in serious injury or death.

1. Remove the excess sawdust from the blade guide assemblies, blade wheel housings, throat and sawdust chute every blade change.



WARNING! Always check to ensure the steel fingers inside the sawdust chute are in place before operating the sawmill. The steel fingers have been designed to help prevent a broken blade or some other object from becoming a projectile and exiting the sawdust chute. Failure to have these fingers in place may result in serious injury.

2. Remove sawdust buildup from the area around the bottom up/down assembly bellows.
3. Remove any sawdust buildup around hydraulic fittings, mast rollers, and bed rails.



7.3 Track Rails & Scrapers

Properly maintaining the sawmill carriage track is critical in preventing corrosion that can cause pitting and scaling on the rail surfaces. Pitted and scaled surfaces can, in turn, cause rough cuts or jerky power feed movement.

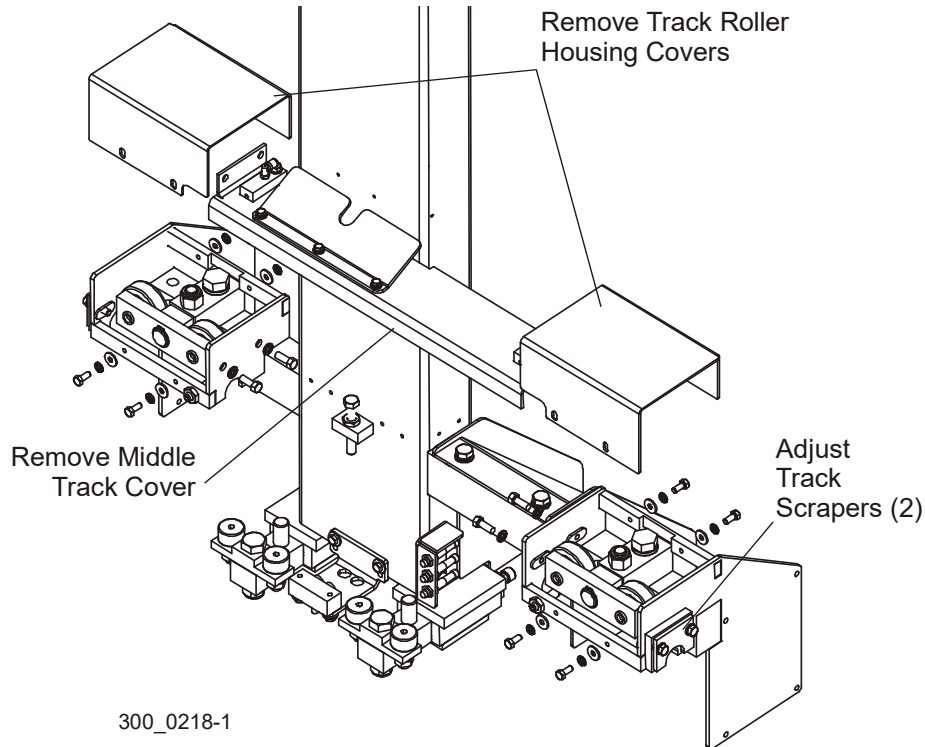

FIG. 7-1

1. Clean track rails to remove any sawdust and sap buildup every fifty hours of operation.
2. Use a light-grade sandpaper or emery cloth to sand off any rust or other adhering particles from the rails.



CAUTION! Keep track rails free of rust. Formation of rust on the track rail in the areas where the bearings roll can cause rapid deterioration of the track rail surface.

3. Lubricate the track rails with Dexron III ATF transmission fluid.

NOTE: Oil lubrication will help protect the rails from corrosive elements such as acid rain and/or moisture from nearby bodies of saltwater (if

applicable). This lubrication is essential to maintain the integrity of the track rails and track rollers and to achieve long service life.

4. Locate the three oil fittings and open the covers.
5. Use an oil can to apply Dexron III until the oiler pads are soaked.
6. Repeat this procedure every eight hours of operation.

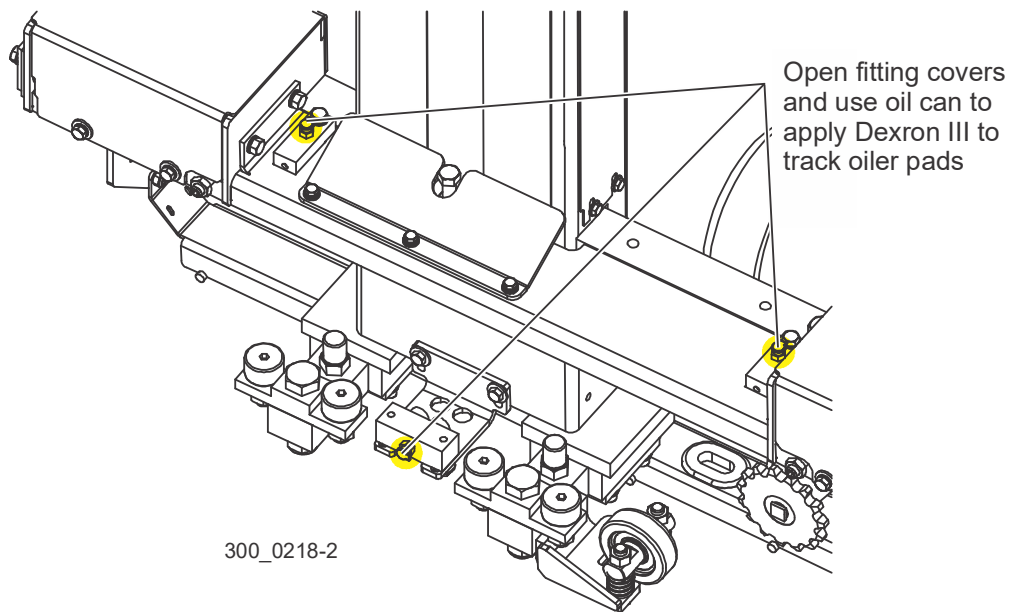

FIG. 7-2

7. Check the track scrapers as needed.
AR
 - The scrapers must fit firmly against the rail.
 - To adjust each scraper, loosen the two mounting bolts and push the scraper downward until it fits firmly against the rail.
8. Retighten the mounting bolts.

7.4 Miscellaneous

1. Oil all chains with Dexron III ATF every fifty hours of operation.

50



CAUTION! Do not use chain lube. It causes sawdust buildup in chain links.

2. Apply a thin film of a Dexron III ATF to the blade guide arm every fifty hours of operation to help prevent it from rusting.

50

3. Adjust the blade guide arm drive chain as necessary to prevent the arm from slipping.

AR

- Loosen the blade guide arm motor mounting plate bolts and slide the motor to take slack out of the chain.
- Adjust the chain by loosen the blade guide arm motor mounting plate bolts and slide the motor to take slack out of the chain.

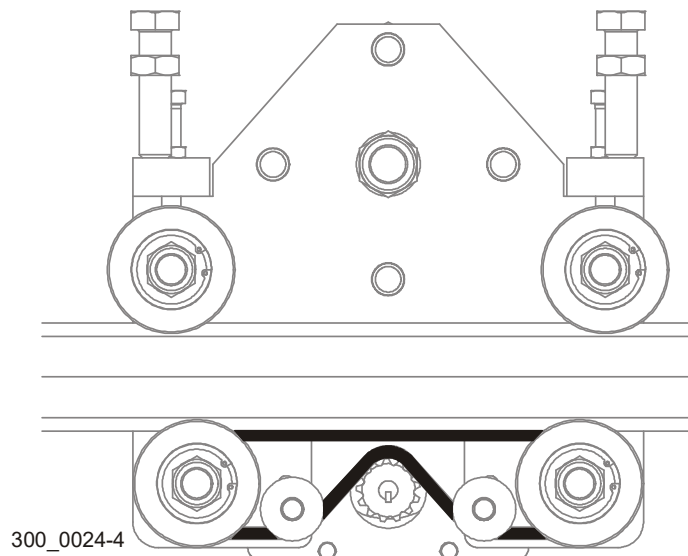

FIG. 7-3 BLADE GUIDE ARM CHAIN ROUTING

4. Grease the following pivot points with a NLGI No. 2 grade lithium grease every fifty hours of operation:
- the operator seat (2)
 - log clamp (1)
 - log loader (6)
 - log turner (1)

50

rear toe board (1)
board return arm pivots (5)
side supports (6)

5. Check all safety warning decals for readability.

- Remove sawdust and dirt.
- Replace any damaged or unreadable decals immediately.
- Order decals from your Customer Service Representative.

 6. Use Bio Lube #210-5 for replacement lube. Order part number 061412 for 5 gallons at a time.

7.5 Proximity Sensors

Broken Blade Sensor

A sensor located near the motor mounting plate detects when a blade breaks and stops the saw. When a blade breaks, activating the sensor, an alert is sent to the display at the operator's station.

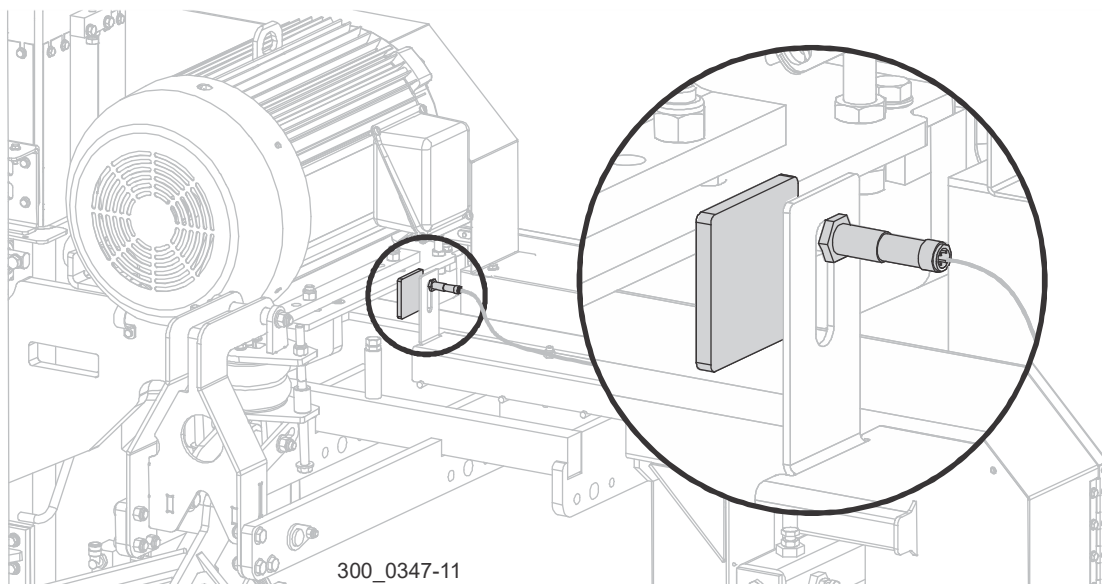

FIG. 7-0

1. Check that the area between the sensor and the motor mount plate are clear of sawdust buildup and/or obstructions that could result in false sensor readings.
2. Set the blade tension.
3. Loosen the nut and adjust the sensor away from the motor mount plate until the sensor light goes out.
4. Adjust back in until the sensor light comes on plus one 1/4 turn.
5. Tighten the nut.

Up/Down Ball Screw Sensor

A sensor located at the middle up/down ball screw mount is activated if the saw head hits an obstruction or lower travel limit as the head is being lowered. A break-away nut sepa-

rates from the mount and the sensor alerts the operator with the message “Head Down Obstructed” on the control display.

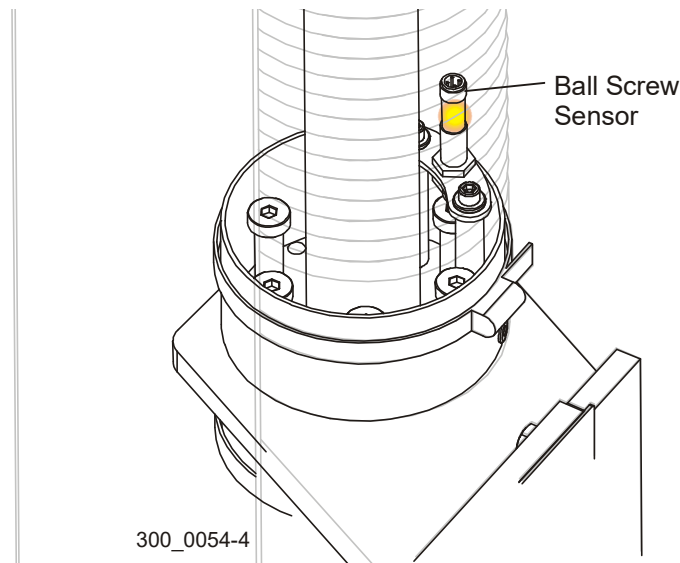





FIG. 7-4

1. Remove the obstruction and move the saw head up to re-engage the ball screw nut.
 - If the error occurs at the bottom of the saw head travel limit, clear sawdust or obstructions from the area around the bottom of the ball screw bellows that might cause the nut to break-away before reaching the actual lower travel limit.
2. Check that the areas between the sensor and the ball screw nut are clear of sawdust buildup or obstructions that could result in false sensor readings.
3. Check that the sensor is lighted when positioned over the ball screw nut.
4. Loosen the nut and adjust the sensor away from the nut until the sensor light goes out.
5. Then adjust back in until the sensor light comes on plus one full turn.
6. Tighten the nut.

7.6 Hydraulic System Maintenance

1. Check the hydraulic tank fluid every fifty hours of operation.

 - The sight gauge on the tank should indicate a fluid level between LOW and HIGH.
2. Add an all-season hydraulic fluid such as Conoco HVI32 as needed to maintain proper fluid level.

NOTICE If the fluid appears brown or cloudy, has an unusual 'burnt' odor, or if there is a sudden rise in oil temperature above 160°, **completely drain the hydraulic tank**. Remove and clean the suction strainer from the end of the hydraulic tank. Blow out any debris from the strainer and clean with a non-petroleum solvent before reinstalling to the tank. Refill tank with new fluid

3. Inspect the hydraulic lines and fittings for leaks every fifty hours of operation or as fluid appears around the machine.

4. Replace the cartridge filter on the back of the hydraulic fluid tank every 500 hours of operation.

5. Completely drain the reservoir every 2000 hours of operation.

 - 1). Remove and clean the suction strainer from the end of the hydraulic tank.
 - 2). Blow out any debris from the strainer and clean with a non-petroleum solvent before reinstalling to the tank.
 - 3). Refill tank with new fluid

NOTICE Close the hydraulic power unit pressure gauge valve to isolate the pressure gauge from the hydraulic circuit during normal machine operation.

NOTE: The pressure gauge is used for troubleshooting purposes only.

7.7 Blade Wheel Bearings & Scrapers

1. Lubricate the blade wheel hub bearings every 750 hours of operation with a high-quality synthetic grease such as Amoco Rycon #2 or Chevron SRI #2.
2. Remove the dust cap from the hub.
3. Add grease until the new grease is seen exiting the hub bearings.
4. Replace the dust cap.

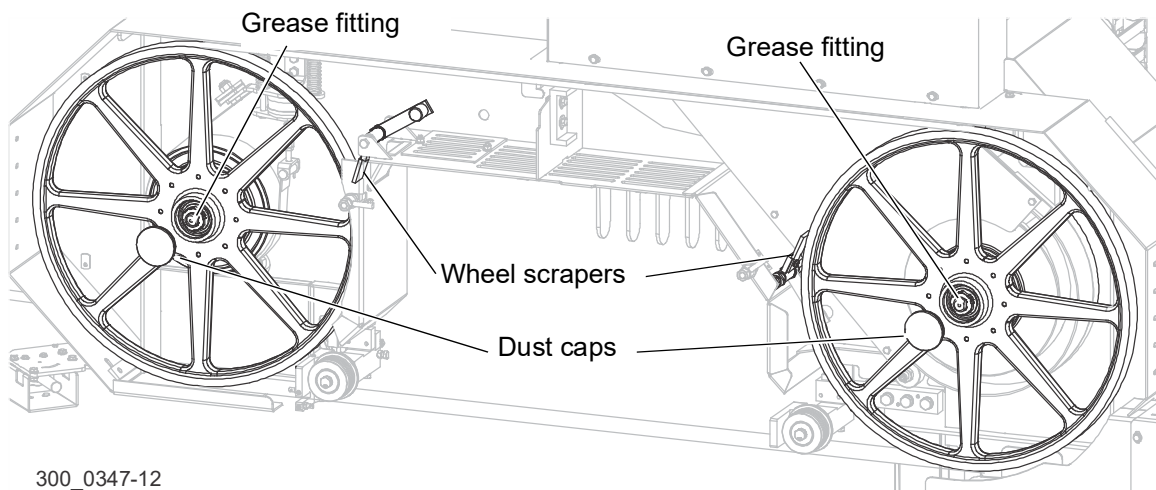

FIG. 7-4

5. Inspect the blade wheel scrapers at every blade change.
 - The scrapers are self-adjusting and only need replaced when they no longer contact the blade wheel.
 - When one side of the scraper is worn, remove it and flip it over to use the other side.

7.8 Up/Down System

500

UP/DOWN BALLSCREW

Lubricate the up/down ballscrew with TriGEL-450R grease every 500 hours of operation.

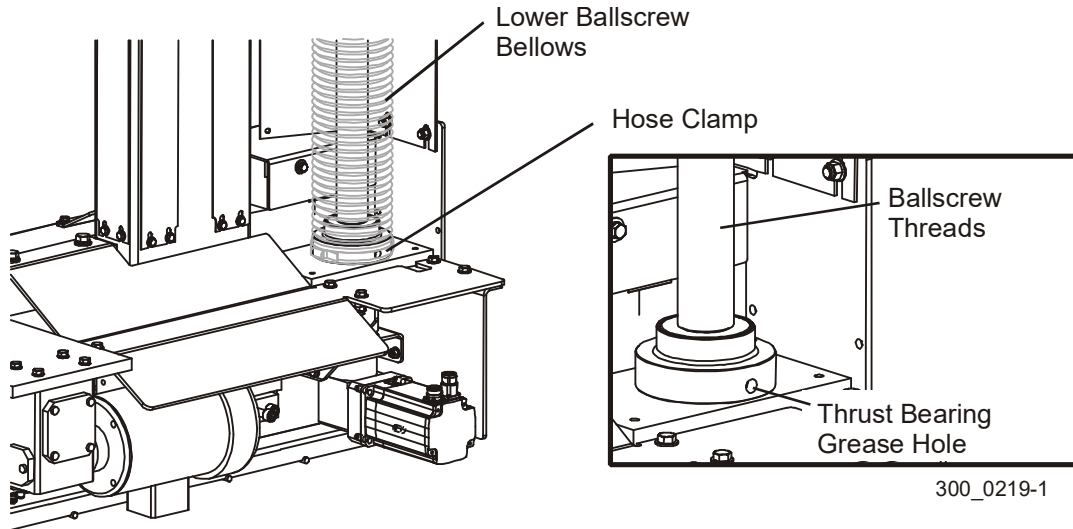

FIG. 7-4

1. Lower the saw head all the way down and blow off sawdust from around the upper ballscrew bellows.
2. Raise the saw head all the way up and blow off sawdust from around the lower ballscrew bellows.
3. Remove the top hose clamp from the lower bellows to access the ballscrew.
4. Inspect the condition of the ballscrew lubricant.

NOTE: If the lubricant appears to have dispersed or is dry or crusted, reduce the maintenance interval.

5. Remove any old grease and/or particle buildup from the screw.
6. Apply 10cc of lubricant directly to the ballscrew threads just below the ballscrew nut and continue to lubricate the threads down as far as the lower bellows will allow.
7. Remove the bottom hose clamp from the lower bellows.

8. Lift the bellows up and continue applying lubricant to the ballscrew threads down to the thrust bearing housing.
9. Remove the screw plugging the hole in the thrust bearing mount.
10. Apply 5cc of lubricant through the hole to lubricate the thrust bearing then replace the plug screw.
11. Reattach the lower ballscrew bellows and secure with the hose clamps.
12. Raise and lower the saw head to work the grease along the entire length of the ballscrew.

NOTE: Wood-Mizer provides ballscrew grease in 10cc syringes for convenient application (p/n 042399). Lubrication may be required sooner if environmental conditions require it. If the lubricant appears to have dispersed or is dry or crusted, reduce the time between maintenance.

UP/DOWN MAST

50

1. Check the up/down mast rails for excessive sawdust buildup every 50 hours of operation.
2. Adjust the mast rail scrapers as necessary.

7 Maintenance

Up/Down System

3. Turn the adjustment bolts clockwise to tighten the scrapers until just snug against the mast rails; **do not overtighten**.

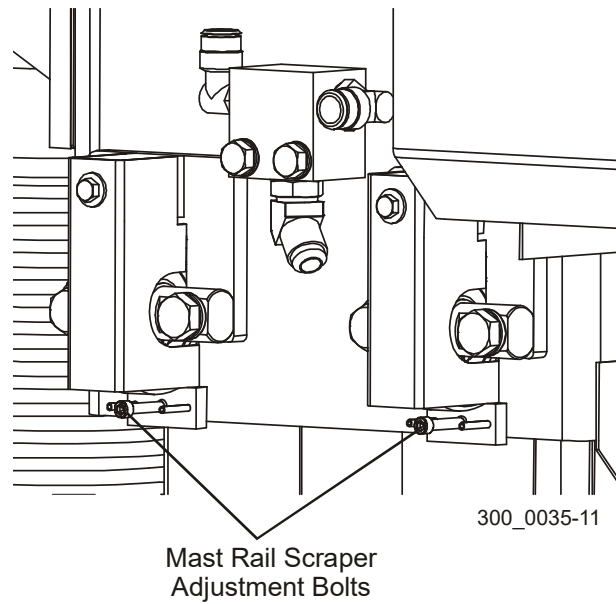

FIG. 7-4

7.9 Power Feed

50

1. Check the feed chain tension every 50 hours of operation and adjust as needed.
2. Move the saw head to the front of the mill (closest to control station).
3. Measure the distance from the top of the bed rail to the lowest point of the power feed chain tension.
4. Use the adjustment nut on the feed tensioner at the rear of the mill to tighten or loosen the power feed chain.
5. Adjust the chain until it measures 11 inches ($\pm 1/2$ ") from the top of the top rail at its lowest point.



CAUTION! Do not overtighten the feed chain. Damage to the power feed motor may result.

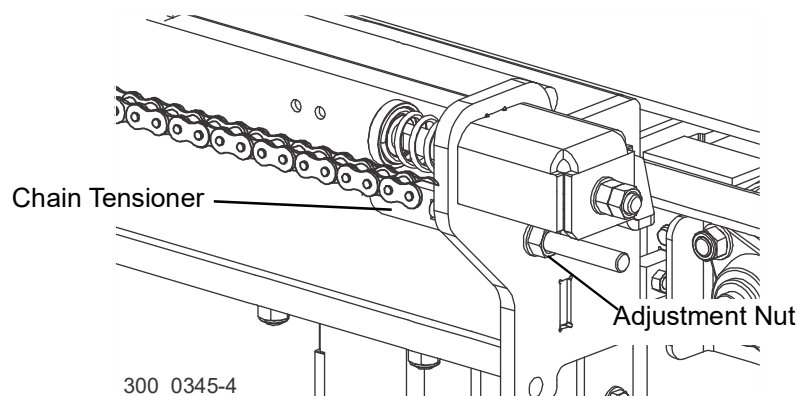

FIG. 7-5

7 Maintenance

Power Feed

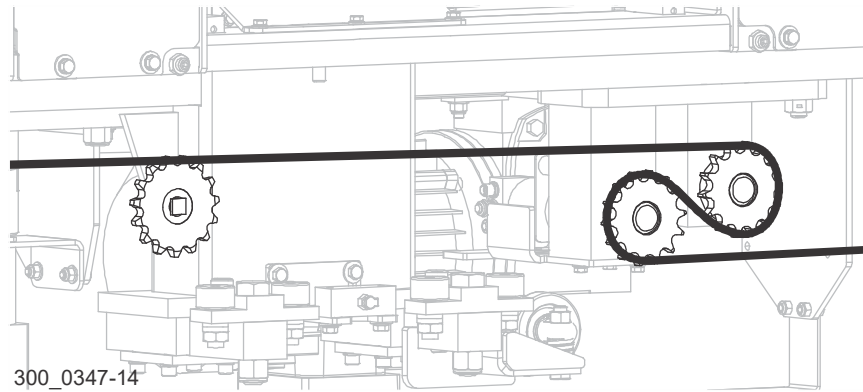

FIG. 7-6

6. Lubricate the feed chain with Dexron III ATF every fifty hours of operation.

50



CAUTION! Do not use chain lube. It causes sawdust buildup in chain links.

7. Check the power feed gearbox oil level.

A/R

Add a synthetic gear oil such as Mobil Glygoyle 460 as needed.

8. Drain and refill the gearbox with 19 - 22 ounces of oil after the first 100 hours of sawmill operation.

5000

9. Repeat every 5000 hours or once a year, whichever comes first.

10. Inspect the power feed drive system for worn sprockets, chain links, etc., every 500 hours of operation.

500

11. Replace or repair components as necessary.

12. Check that the feed drive shaft coupler set screws are tight.

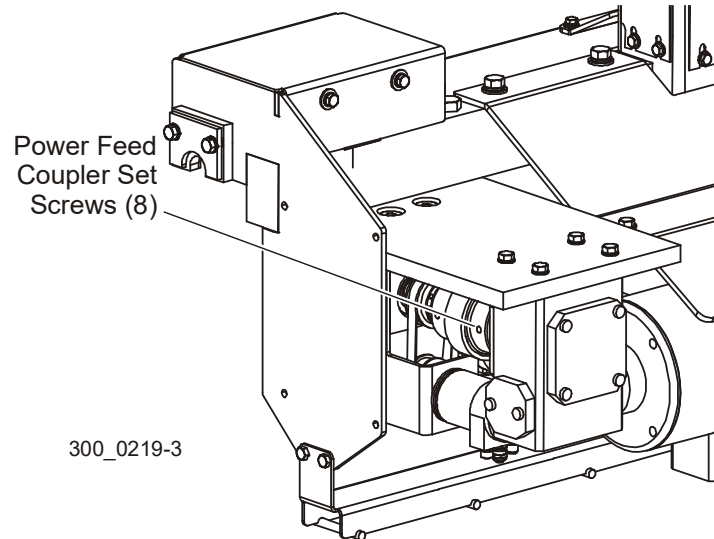

FIG. 7-7

7.10 Drive Belt Tension & Alignment



Check the drive belt tension and alignment after the first 5 hours of operation, then every 50 hours thereafter.



WARNING! Do not adjust the drive belt with the motor running. Failure to follow this could result in serious injury or death.



CAUTION! Keep proper tension on the drive belt. Improper tension can ruin the belt. A loose drive belt can also cause wavy cuts, the blade to slow or stop in the cut or the cruise control to not operate properly.

Before tensioning the belt, check the alignment of the motor and drive pulleys. Misaligned pulleys will result in reduced belt life.

INSTALL, TENSION, AND TRACK A BLADE

1. Turn the machine off, disconnect, and lock out the power supply.
2. Remove belt covers as necessary and place a string across the back of the drive pulley.
3. Pull the string tight and position it contacts the pulley on each side of the pulley.
4. Check the position of the motor pulley against the string for properly aligned the string will contact both sides of each pulley.
5. Adjust the motor pulley to align with the drive pulley.
6. Move the motor pulley straight in or out by loosening the pulley bushing and move the pulley in or out on the motor shaft.

NOTE: To adjust the angle of the motor pulley, loosen the motor mount bolts and tilt the motor as necessary. Retighten the motor pulley bushing and/or mounting bolts and recheck the alignment with the string.

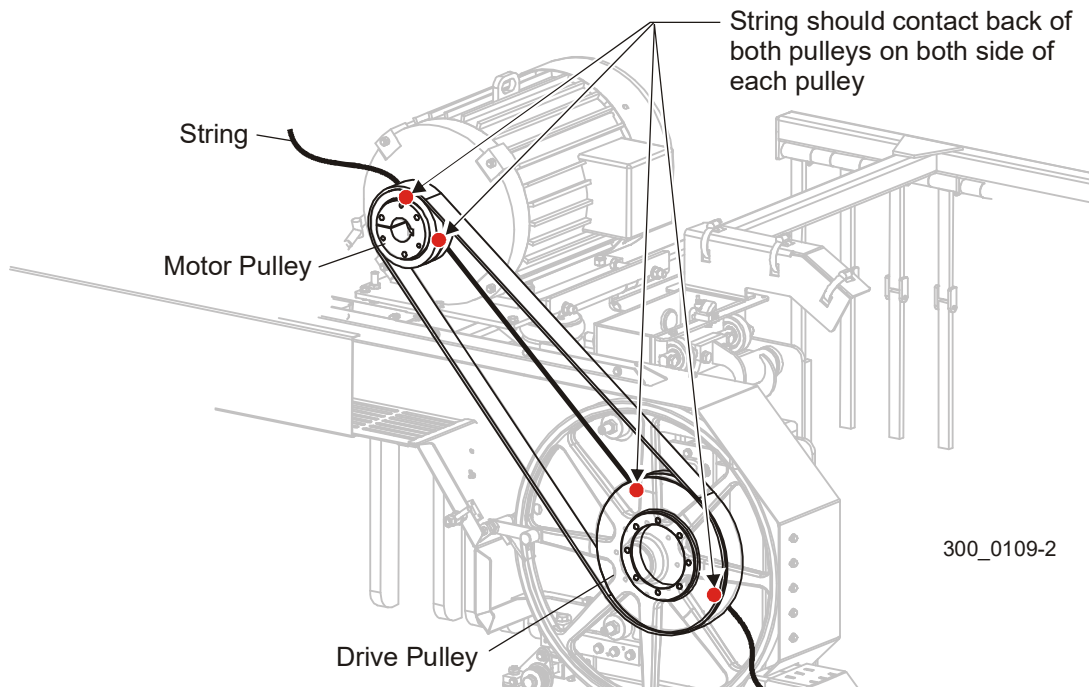

FIG. 7-8

7. Check after first 5 hours that the belt is properly tensioned ($1/2''$ (12.5mm) deflection with 34 lbs. (15.4kg) of deflection force).
8. Check after each subsequent 50 hours the belt remains properly tensioned.
9. Adjust the belt by loosening the four motor mount bolt nuts.
10. Loosen the adjustment bolt jam nuts and turn both adjustment bolts to move the motor and tension the belt.
11. Recheck belt tension.
12. Adjust as necessary.

7 Maintenance
Drive Belt Tension & Alignment

13. Retighten the adjustment bolt jam nuts and motor mount bolt nuts.

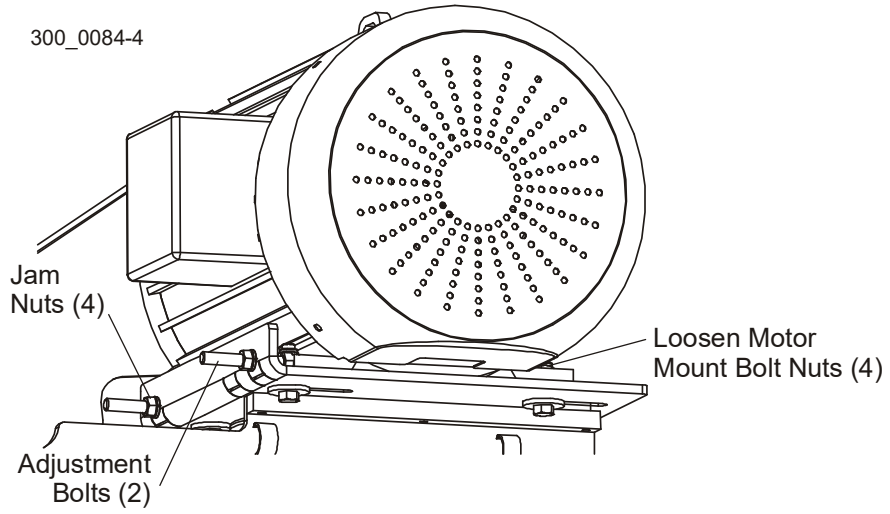

FIG. 7-9

7.11 Turner Chain Tension

NOTICE If the chain(s) become too loose, the log will catch on the support bracket and not turn.

A/R Adjust the turner chain tension the log turner(s) as necessary to keep the turner(s) operating properly.

1. Loosen the clamping bolt nut and the jam nut on the adjustment bolt.
2. Turn the adjustment bolt counterclockwise to tighten the chain until it is aligned with the curved portion of the support bracket.
3. Retighten the jam nut and the clamping bolt nut.

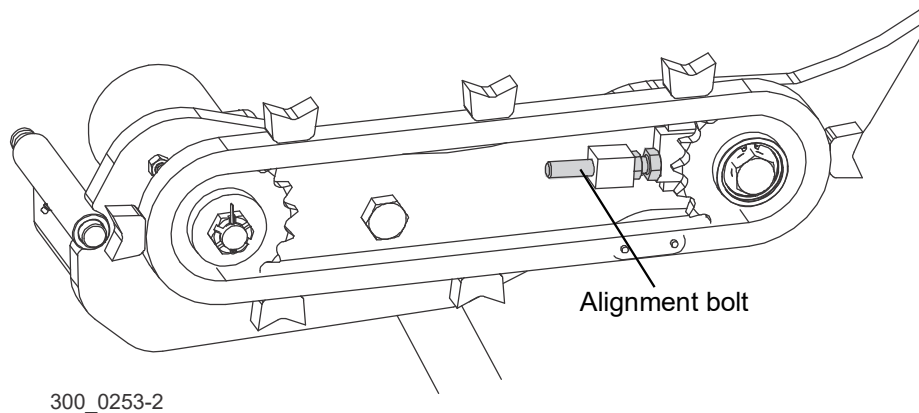

FIG. 7-9



Maintenance

Turner Chain Tension

7.12 Maintenance Chart

(Check Engine And Option Manuals For Additional Maintenance Procedures)		
	PROCEDURE	REFERENCE
Daily		
	Inspect blade guide /roller wear	See Section 5.1
	Remove excess sawdust from blade wheel housings, sawdust chute and blade guides	See Section 7.2
	Inspect fingers inside sawdust chute	See Section 7.2
	Inspect blade wheel scrapers (Optional Crowned Blade Wheels Only)	See Section 5.7
	Oil track rail pads	See Section 7.3
	Clean sawdust from bottom up/down ballscrew bellows	See Section 7.2
Every 25 Hours		
	Check Blade Guide Spacing	See Section 5.1
Every 50Hours		
	Clean and lubricate track, check track scrapers	See Section 7.3
	Check mast rails and adjust scrapers	See Section 7.8
	Grease pivot points and bearings/Oil chains	See Section 7.4
	Check drive belt tension	See Section 7.10
	Rotate drive/idle blade wheel belts/Check for wear (Standard Belted Blade Wheels Only)	See Section 5.7
	Lubricate feed chain and check chain tension	See Section 7.9
	Inspect hydraulic lines & fittings	See Section 7.6
	Check hydraulic fluid level	See Section 7.6
Every 500 hours		
	Lubricate up/down ballscrew & thrust bearing	See Section 7.8
	Inspect feed chain, sprockets and coupler	See Section 7.9
	Replace hydraulic system filter	See Section 7.6
Every 750 Hours		
	Lubricate blade wheel bearings	See Section 5.7
	Inspect hydraulic pump motor brushes	See Section 7.6
Every 1500 hours		
	Replace power feed encoder bearings	
Every 5000 hours		
	Replace power feed gearbox oil ¹	See Section 7.9

¹ Replace fluid after first 100 hours, then every year or 5000 hours thereafter.

SECTION 8 HYDRAULIC INFORMATION

8.1 Hydraulic Schematics

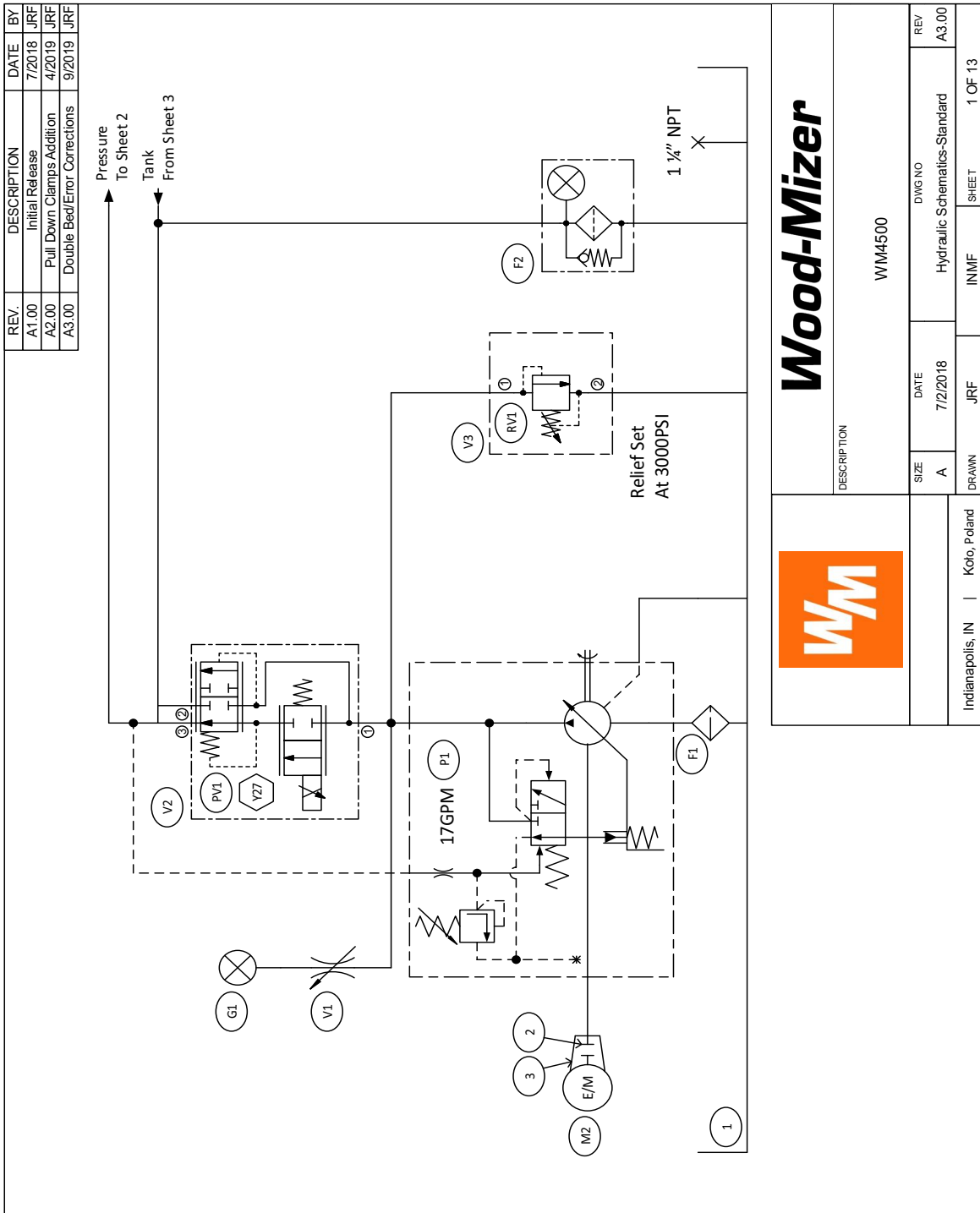

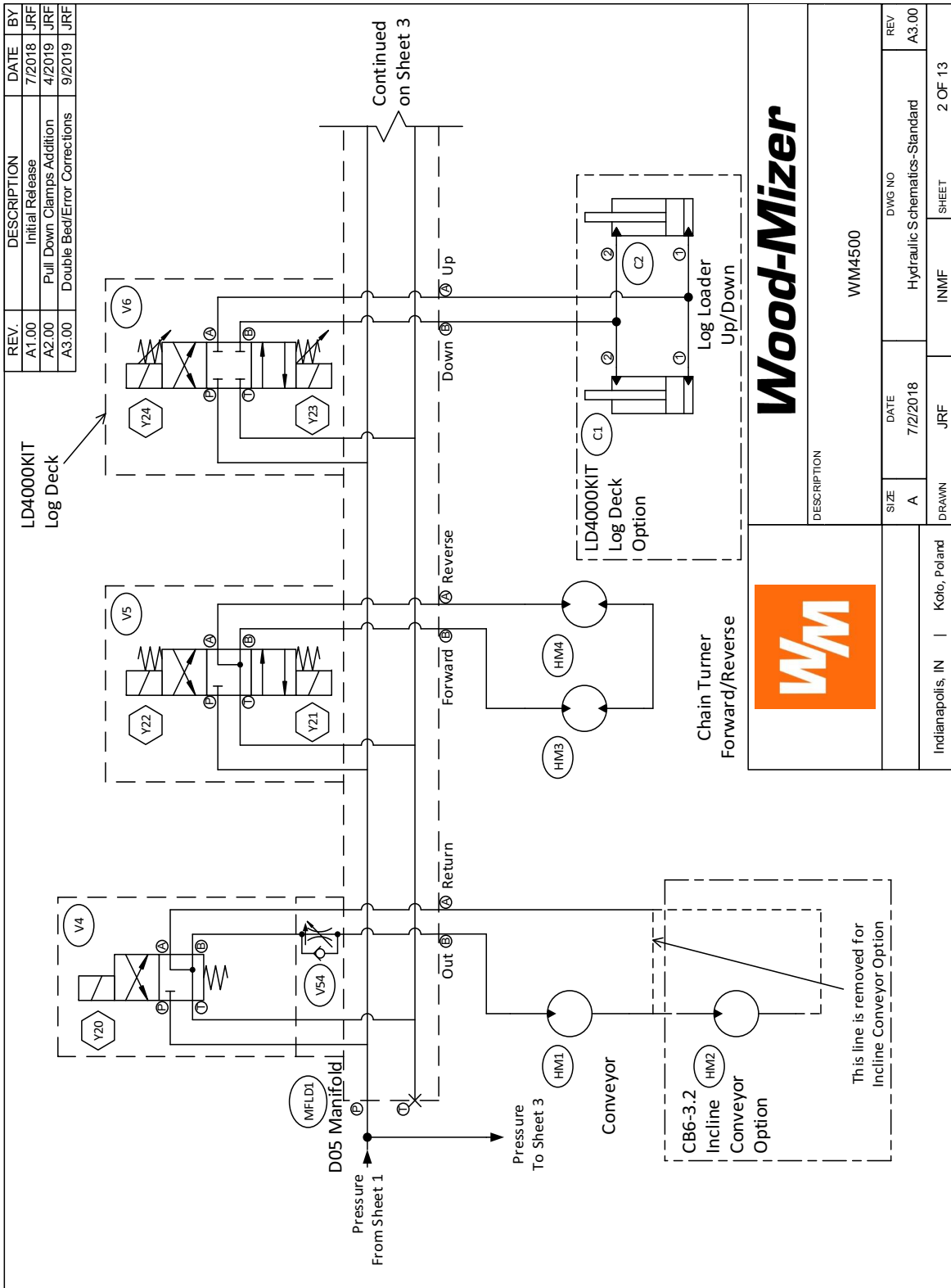

Wood-Mizer



DESCRIPTION		REV
WM4500		A3.00
SIZE	DWG NO	REV
A	Hydraulic Schematics-Standard	A3.00
DRAWN	INMIF	SHEET
Kolo, Poland		2 OF 13

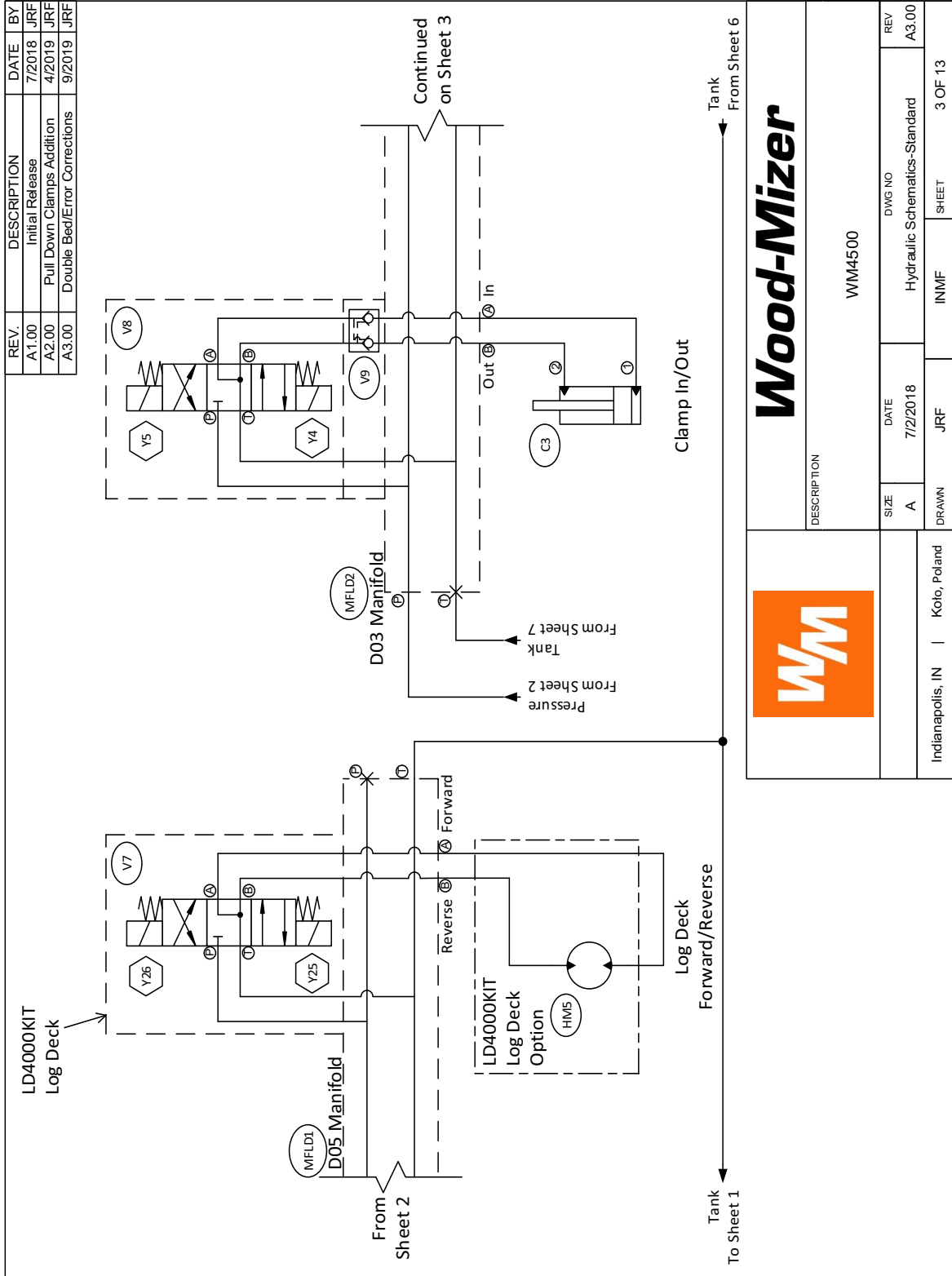

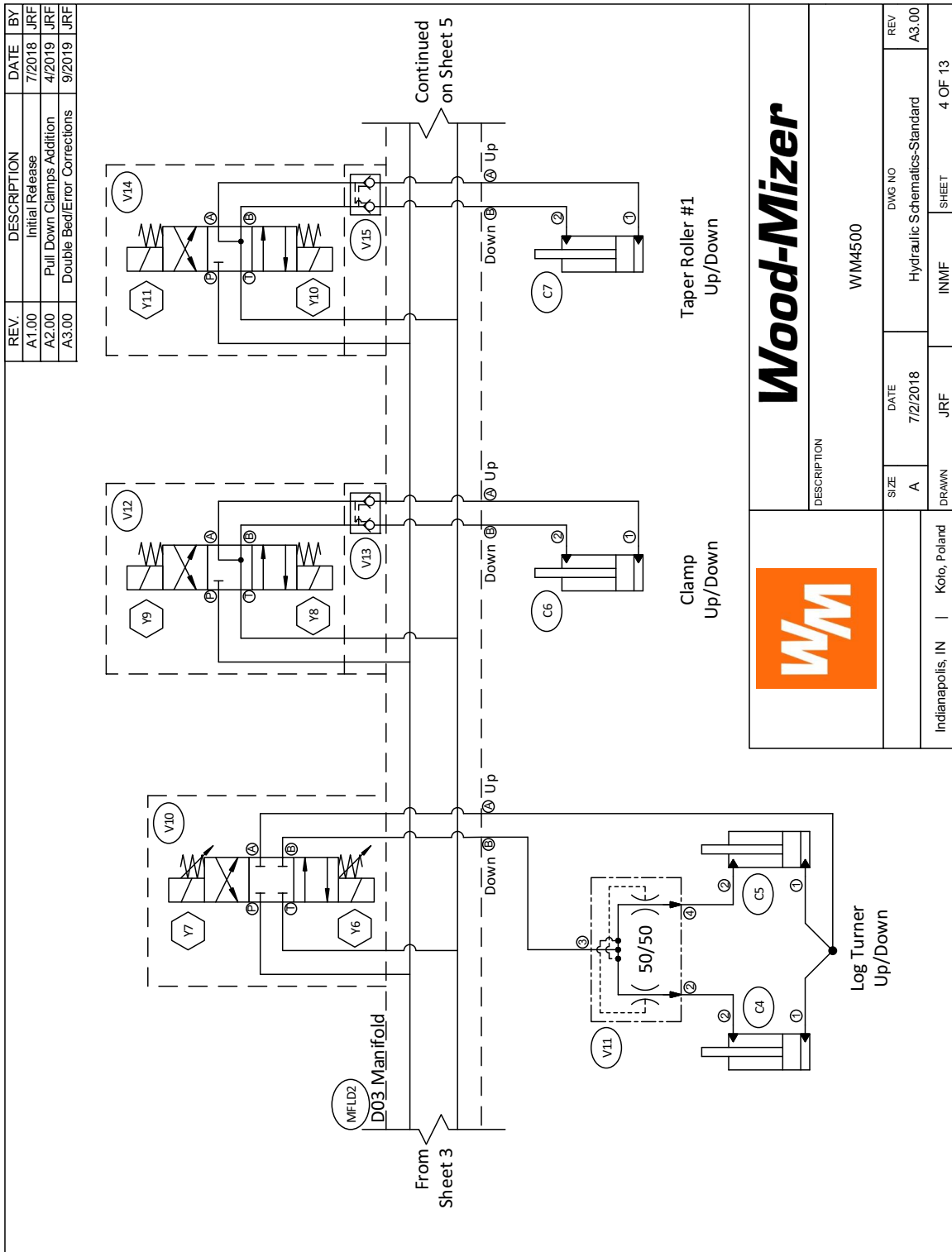

Wood-Mizer





DESCRIPTION

WM4500

INDIANAPOLIS, IN	Koto, Poland	DRAWN	JRF	DATE	7/2/2018	SIZE	A	REV	A3.00
		INMFT	SHEET	4 OF 13					

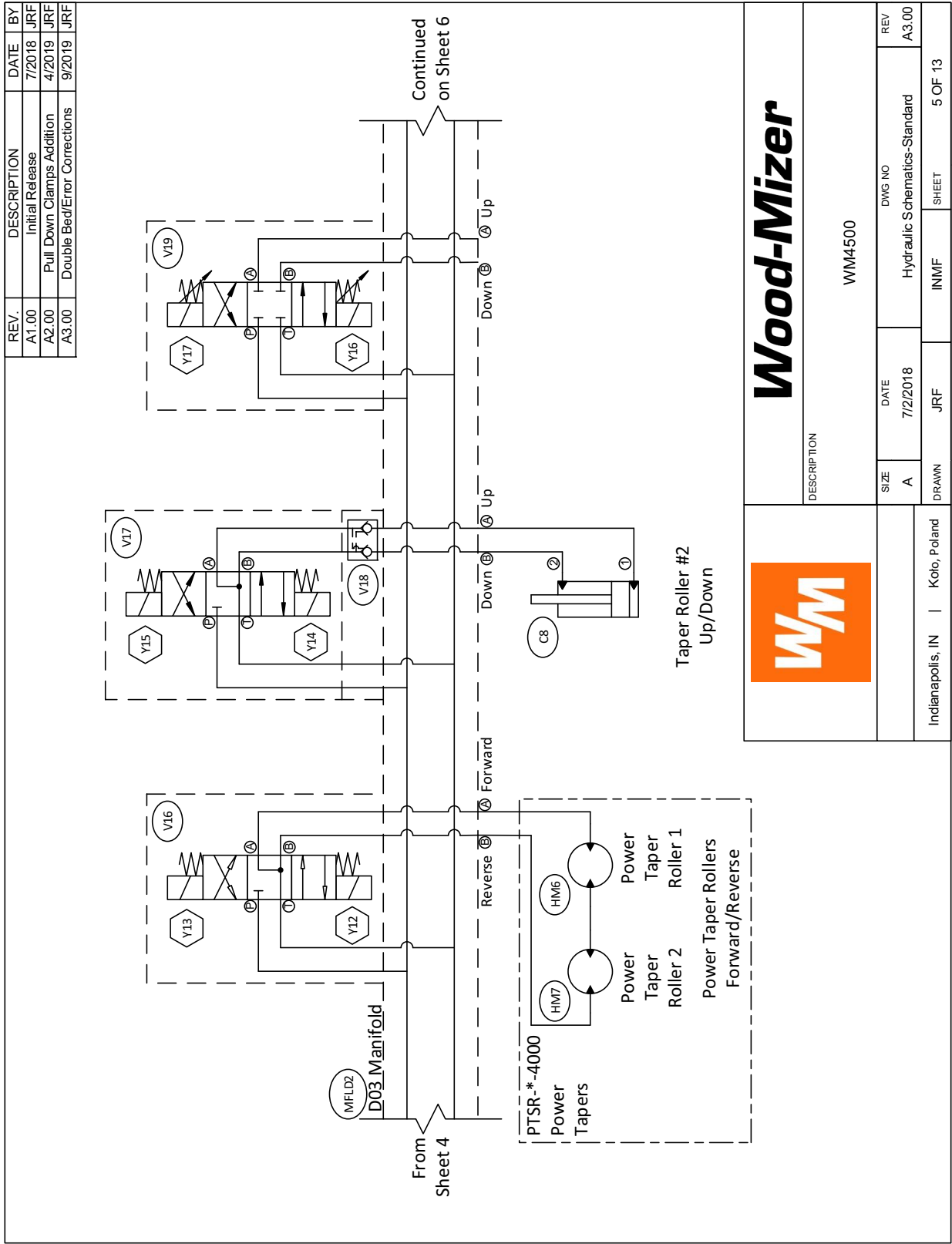
REV.	DESCRIPTION	DATE	BY
A1.00	Initial Release	7/2018	JRF
A2.00	Pull Down Clamps Addition	4/2019	JRF
A3.00	Double Bed/Error Corrections	9/2019	JRF





Wood-Mizer

DESCRIPTION

WM4500

SIZE	DATE	DWG NO	REV
A	7/2/2018	Hydraulic Schematics-Standard	A3.00

DRAWN	JRF	SHEET
Indianapolis, IN	Kolo, Poland	5 OF 13

REV.	DESCRIPTION	DATE	BY
A1.00	Initial Release	7/2018	JRF
A2.00	Pull Down Clamps Addition	4/2019	JRF
A3.00	Double Bed/Error Corrections	9/2019	JRF

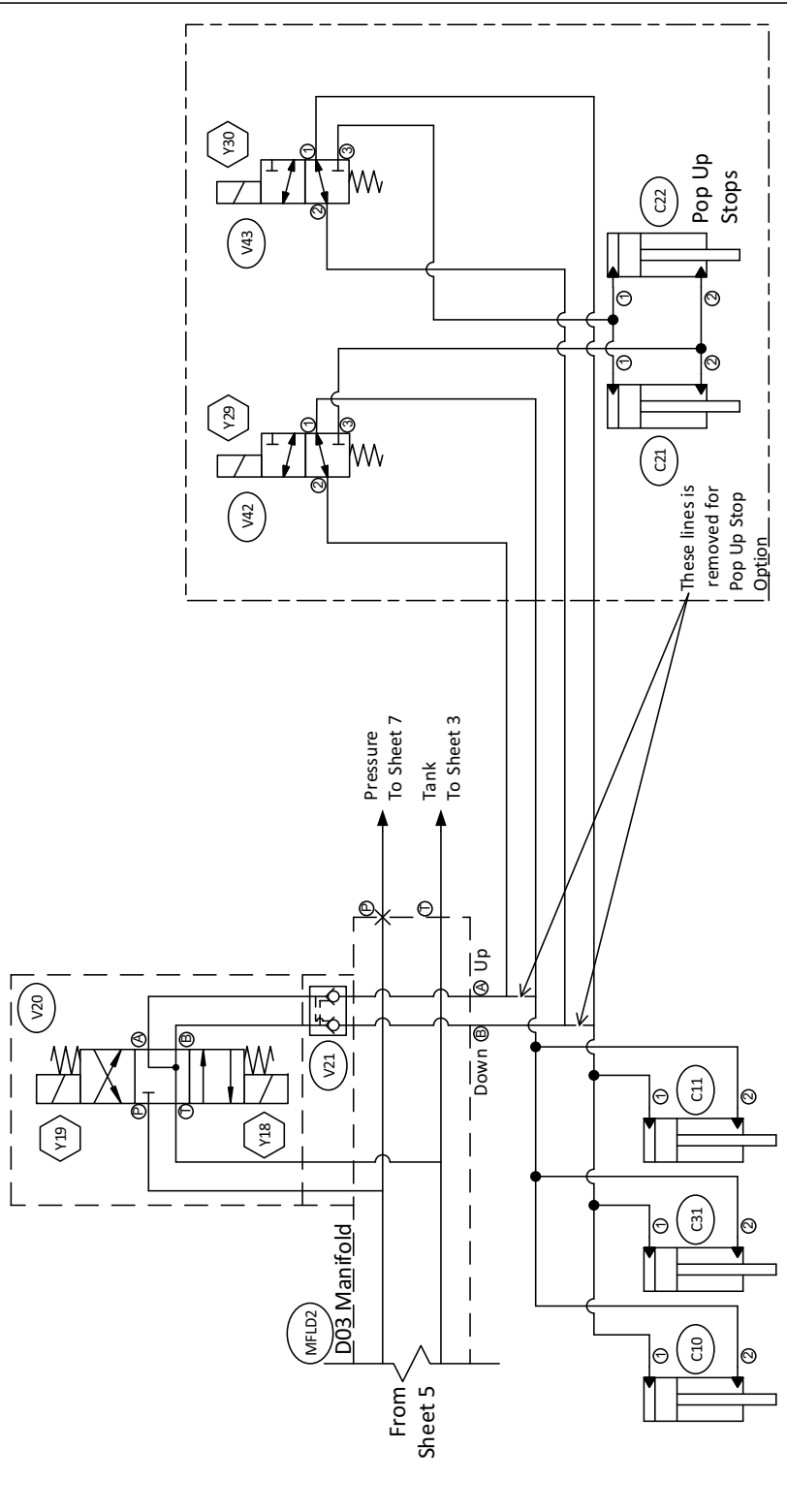

		DESCRIPTION	
		WM4500	
SIZE	DATE	DWG NO	REV
A	7/2/2018	Hydraulic Schematics-Standard	A3.00
DRAWN	JRF	INMF	SHEET
Indianapolis, IN	Kolo, Poland		6 OF 13



Hydraulic Information

Hydraulic Schematics

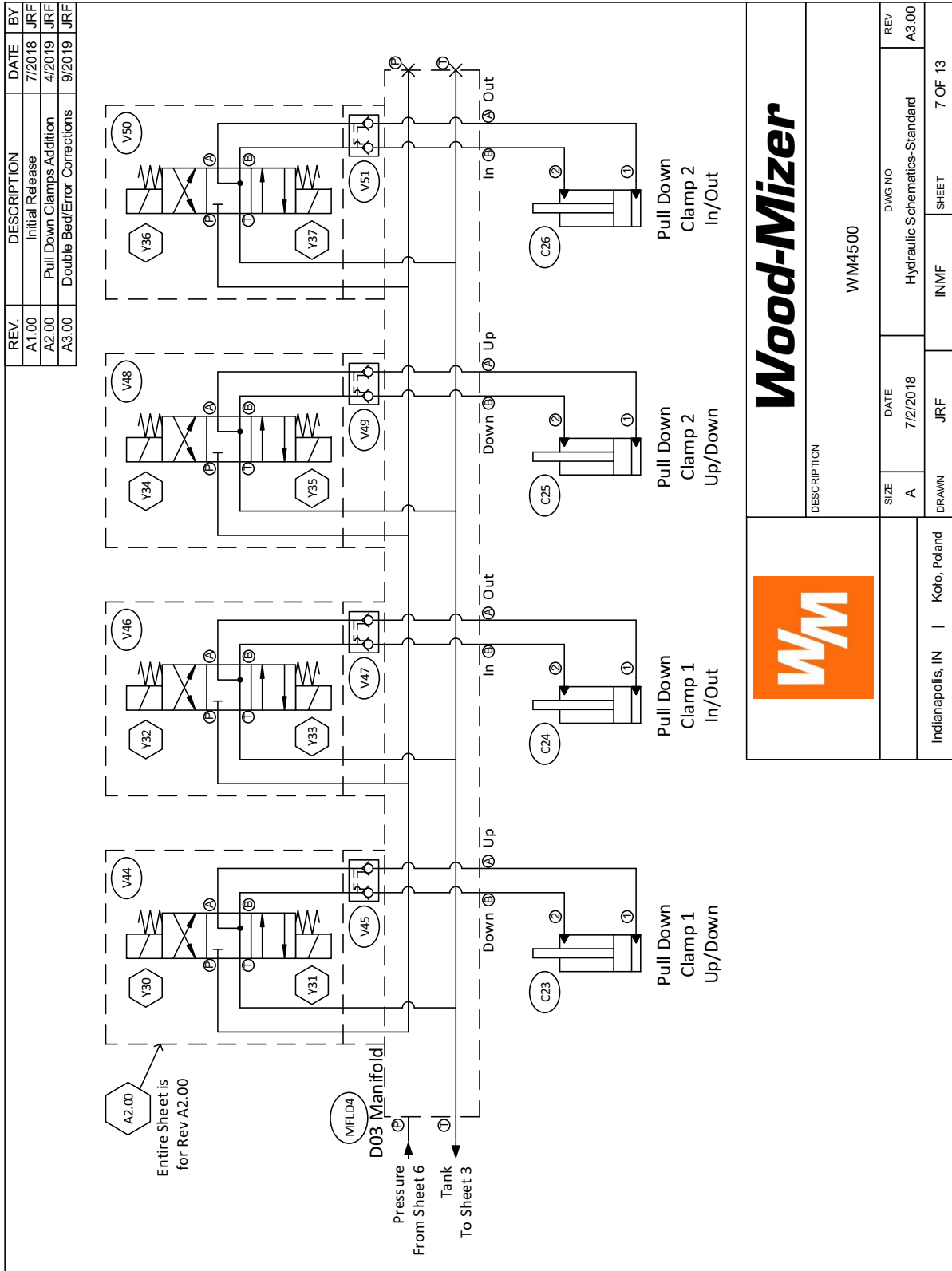

Wood-Mizer

DESCRIPTION

WM4500

8 Hydraulic Information

Hydraulic Schematics

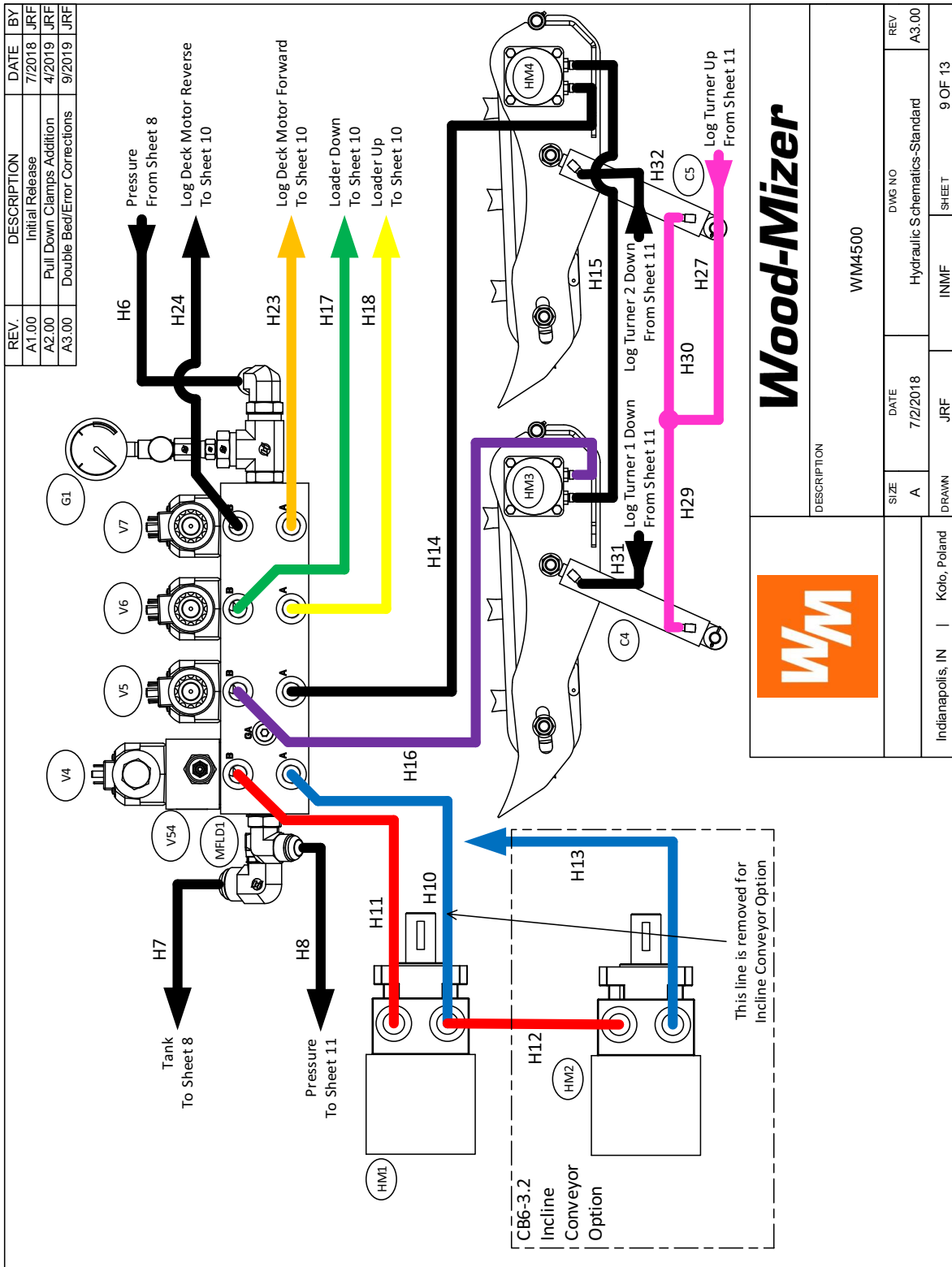

REV.	DESCRIPTION	DATE	BY
A1.00	Initial Release	7/2018	JRF
A2.00	Pull Down Clamps Addition	4/2019	JRF
A3.00	Double Bed/Error Corrections	9/2019	JRF

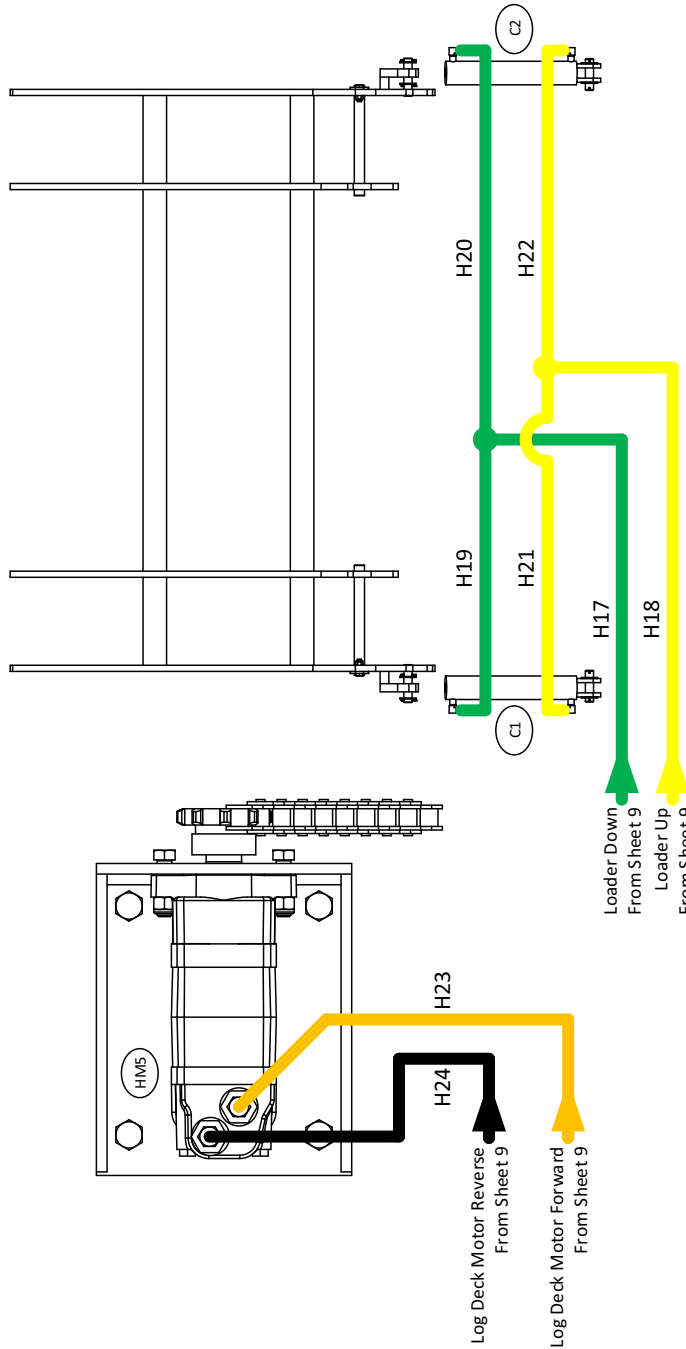

		DESCRIPTION	
		WM4500	
SIZE	DATE	DWG NO	REV
A	7/2/2018	Hydraulic Schematics-Standard	A3.00
DRAWN	JRF	IN/MP	SHEET
Indianapolis, IN	Koto, Poland		10 OF 13

8 Hydraulic Information

Hydraulic Schematics

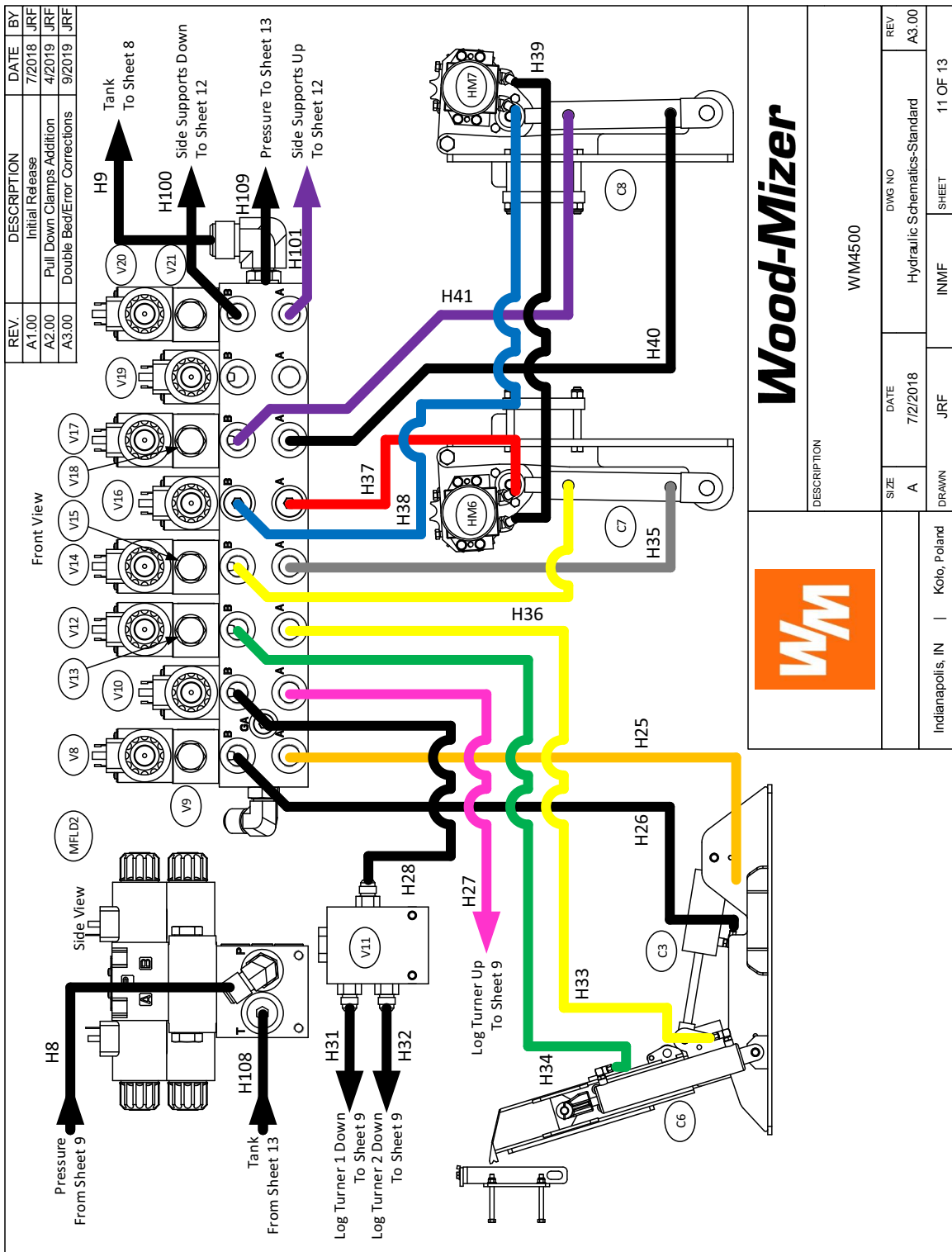

		DESCRIPTION	
		WM4500	
SIZE	DATE	DWS NO	REV
A	7/2018	Hydraulic Schematics-Standard	A3.00
DRAWN	JRF	INMIF	SHEET
Indianapolis, IN	Koto, Poland		11 OF 13

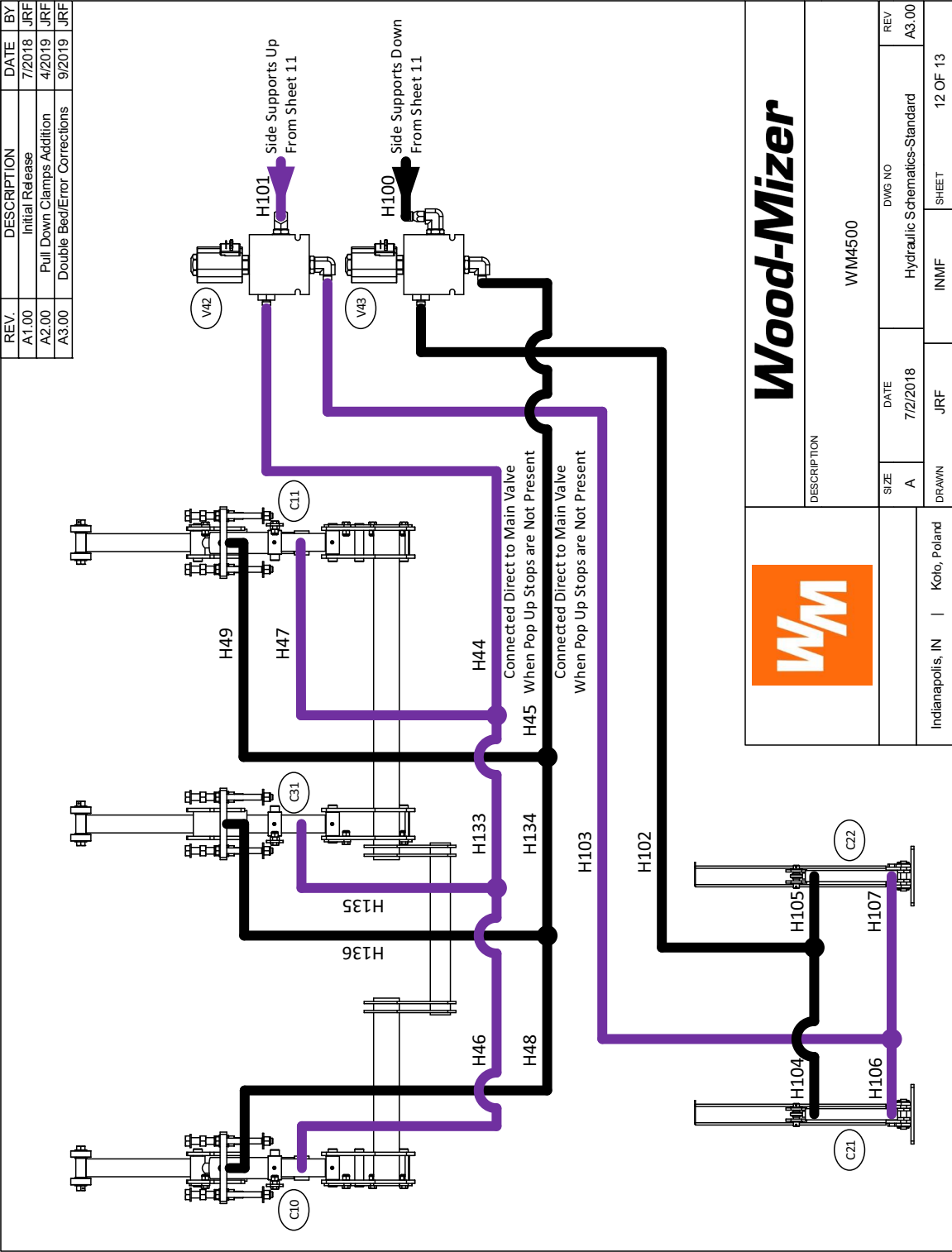

REV.	DESCRIPTION	DATE	BY
A1.00	Initial Release	7/2018	JRF
A2.00	Pull Down Clamps Addition	4/2019	JRF
A3.00	Double Bed/Error Corrections	9/2019	JRF

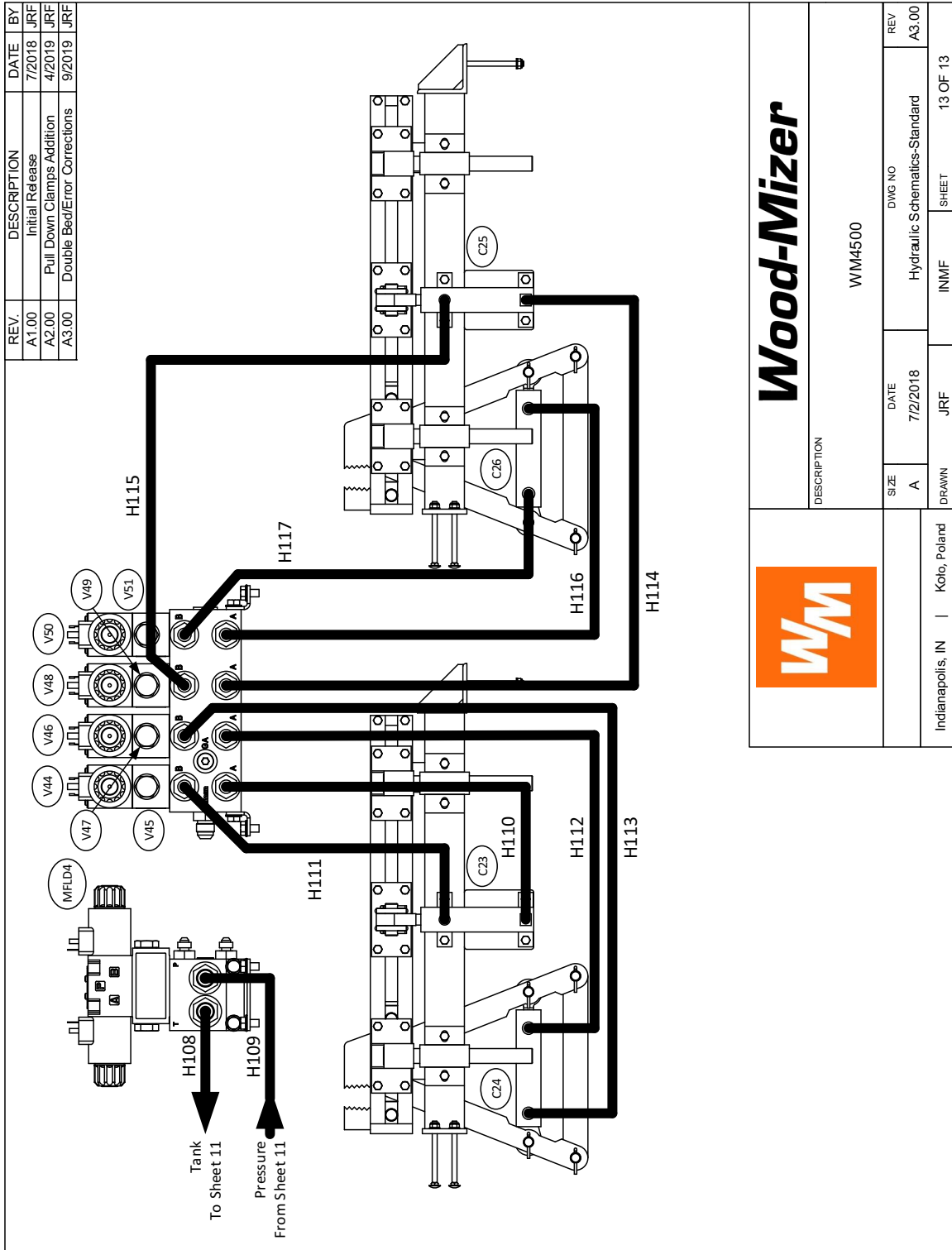

		DESCRIPTION	
		WM4500	
SIZE	DATE	DWG NO	REV
A	7/2/2018	Hydraulic Schematics-Standard	A3.00
DRAWN	JRF	INMIF	SHEET
Indianapolis, IN Kolo, Poland			13 OF 13

8.2 Hydraulic Schematics BX12

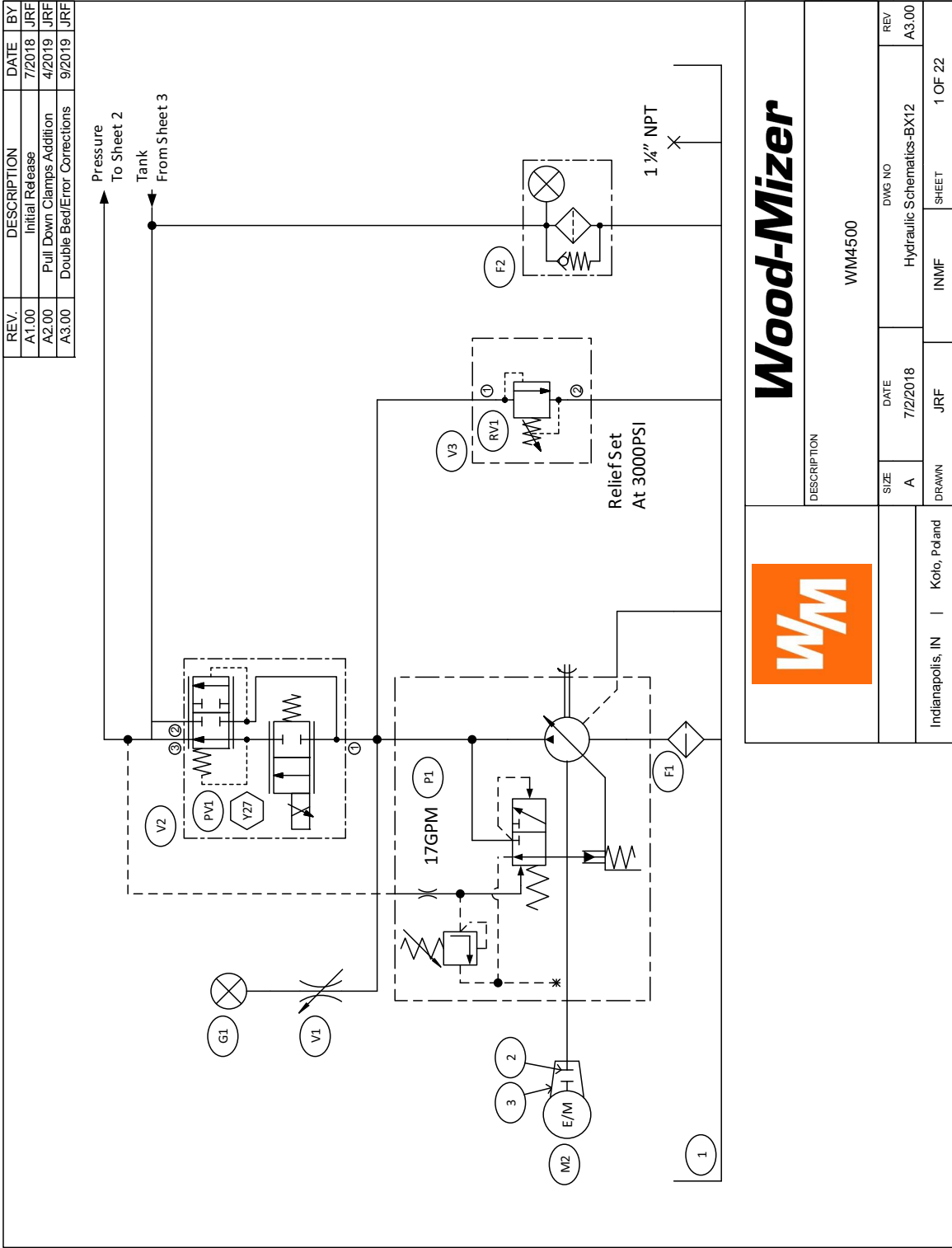

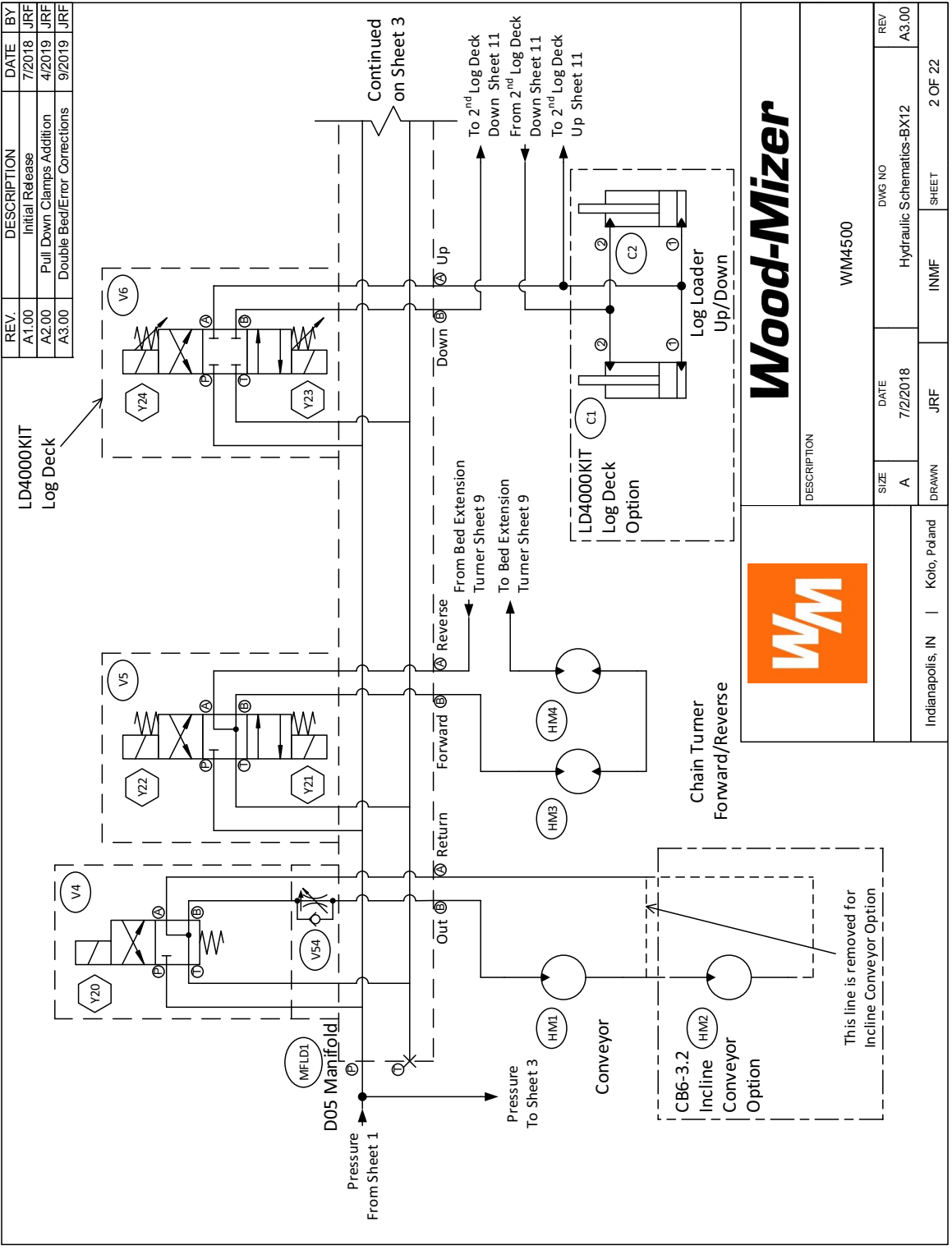

Wood-Mizer



DESCRIPTION		WM4500	
SIZE	DATE	DWG NO	REV
A	7/2/2018	Hydraulic Schematics-BX12	A3.00
DRAWN	JRF	INMF	SHEET
Indianapolis, IN	Kolo, Pol and		2 OF 22

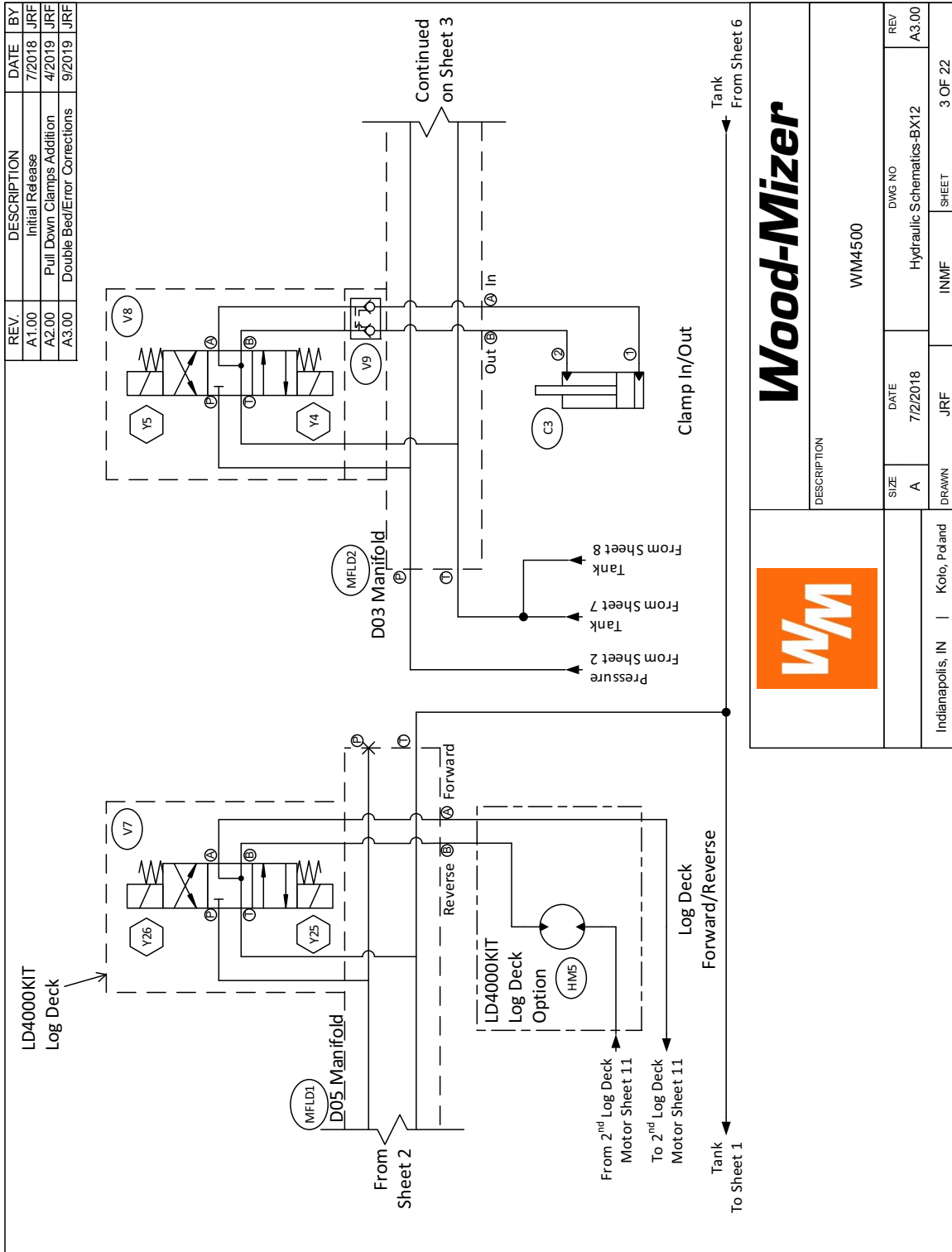

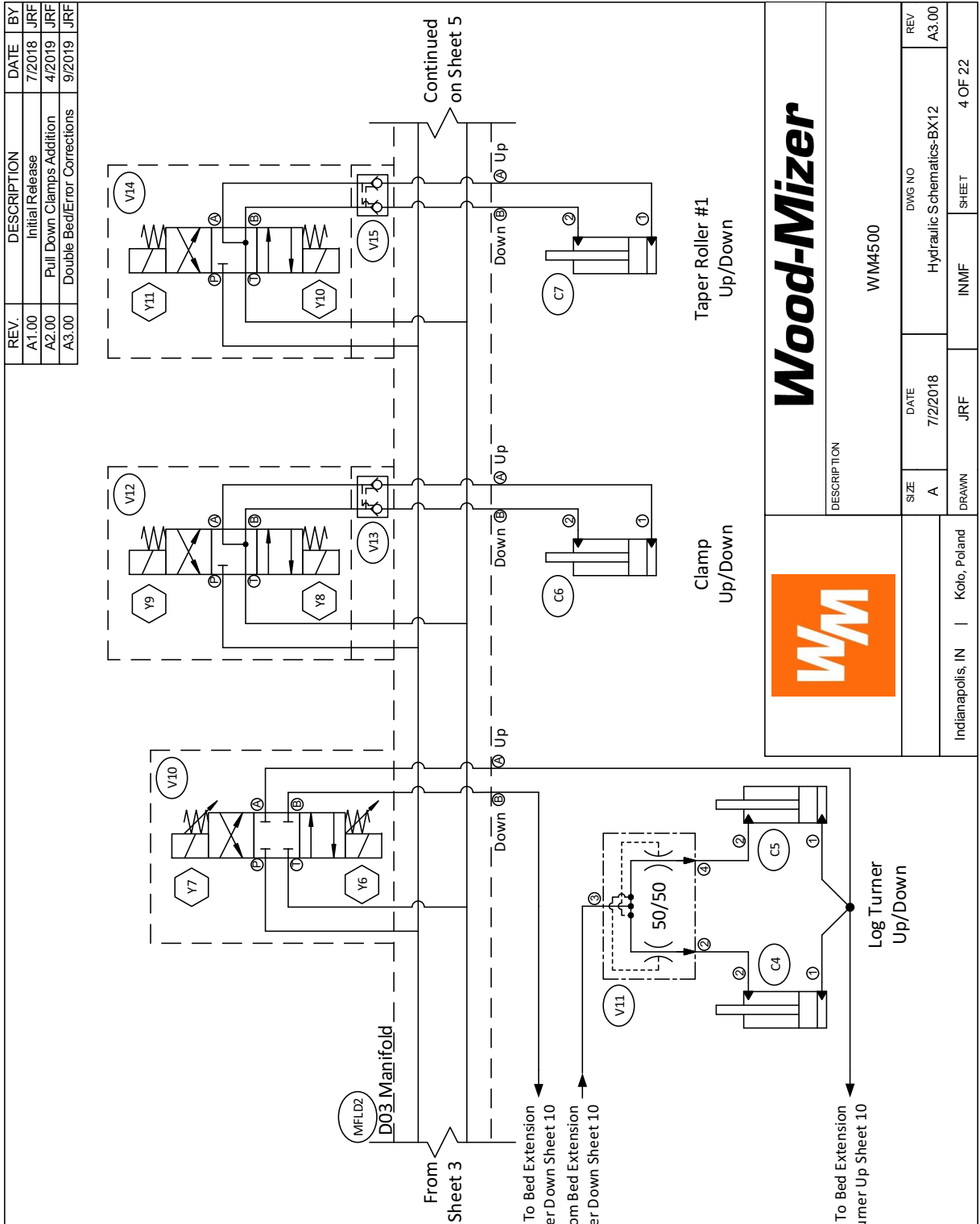

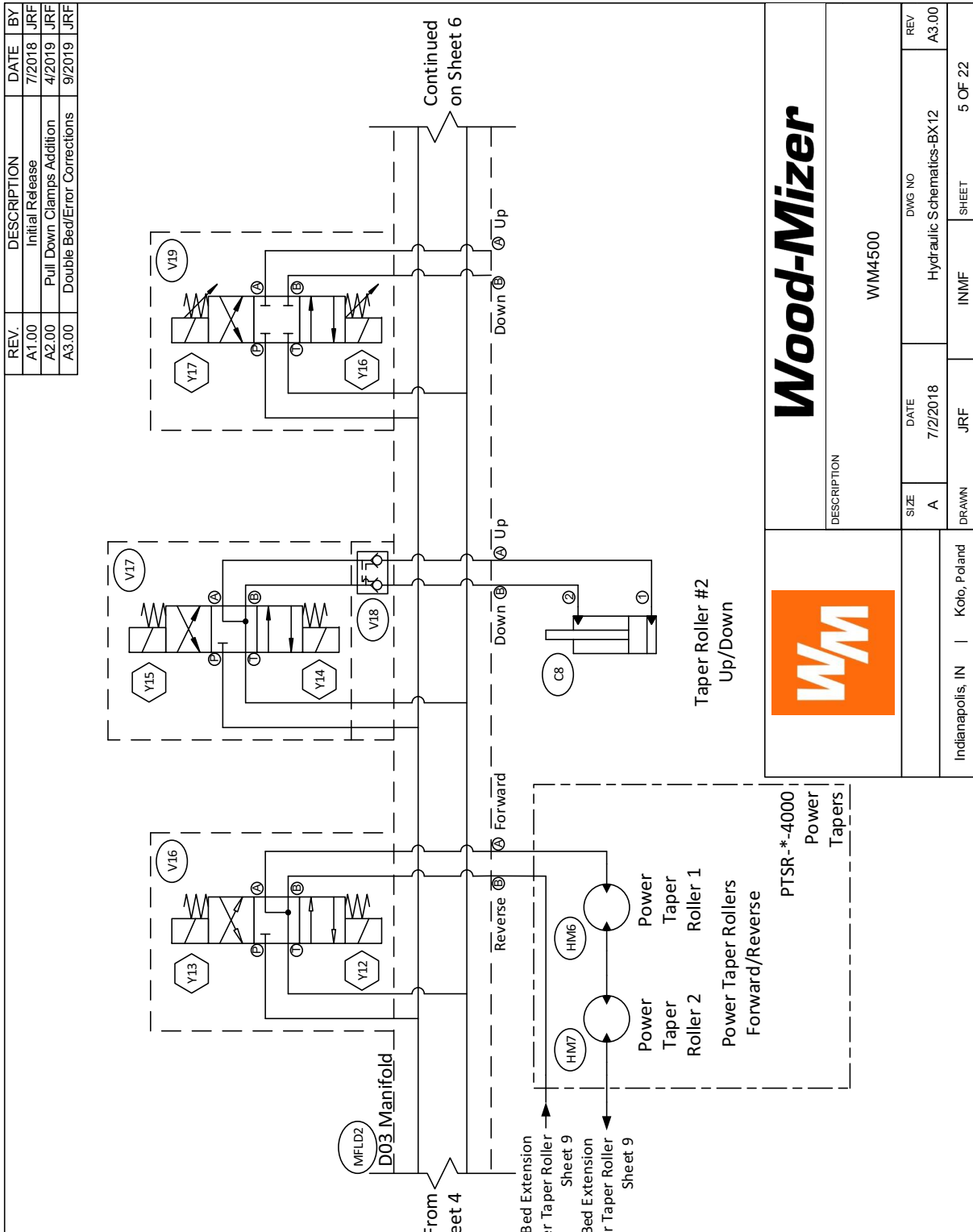



Hydraulic Information

Hydraulic Schematics BX12

REV.	DESCRIPTION	DATE	BY
A1.00	Initial Release	7/2018	JRF
A2.00	Pull Down Clamps Addition	4/2019	JRF
A3.00	Double Bed/Error Corrections	9/2019	JRF

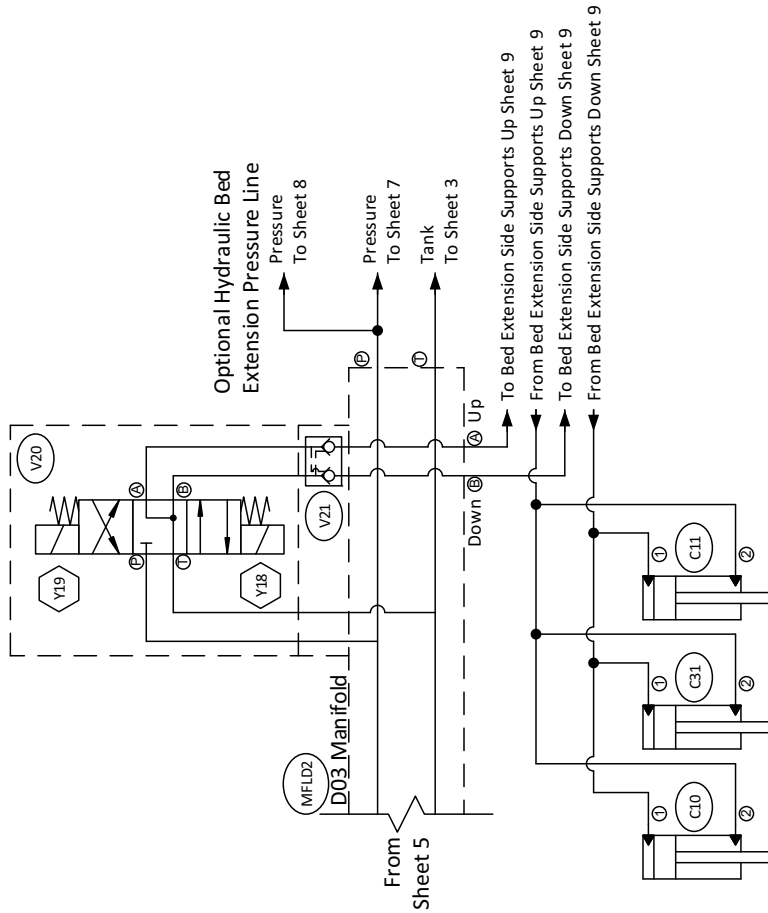

		DESCRIPTION	
		WM4500	
SIZE	DATE	DWG NO	REV
A	7/2018	Hydraulic Schematics-BX12	A3.00
DRAWN	JRF	INMF	SHEET
Indianapolis, IN	Kolo, Poland		6 OF 22

REV.	DESCRIPTION	DATE	BY
A1.00	Initial Release	7/2018	JRF
A2.00	Pull Down Clamps Addition	4/2019	JRF
A3.00	Double Bed/Error Corrections	9/2019	JRF

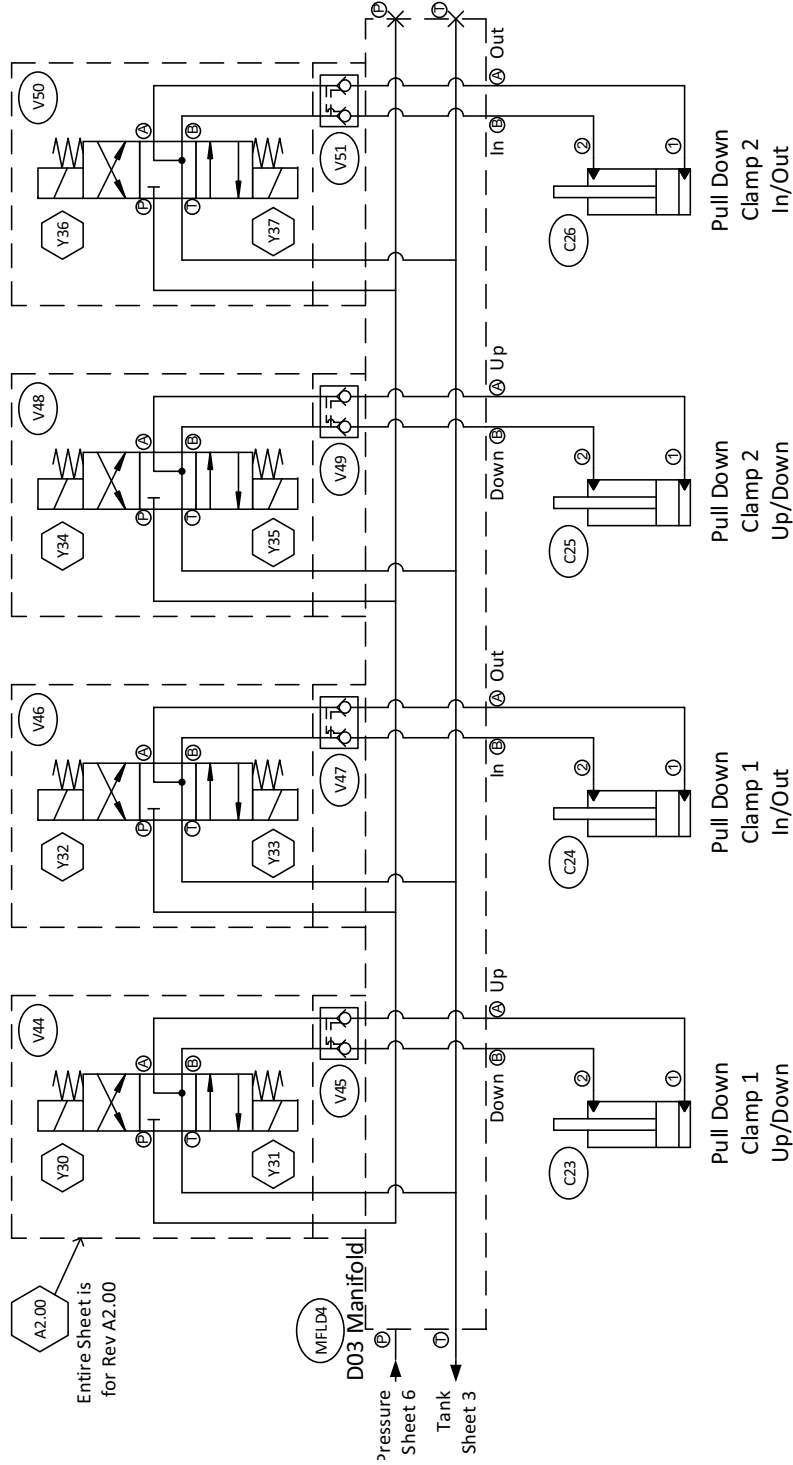

		DESCRIPTION	
		WM4500	
SIZE	DATE	DWG NO	REV
A	7/2/2018	Hydraulic Schematics-BX12	A3.00
DRAWN	JRF	INMF	SHEET
Indianapolis, IN	Koto, Poland		7 OF 22





Hydraulic Information

Hydraulic Schematics BX12

Optional Hydraulic Bed Extension D03 Manifold

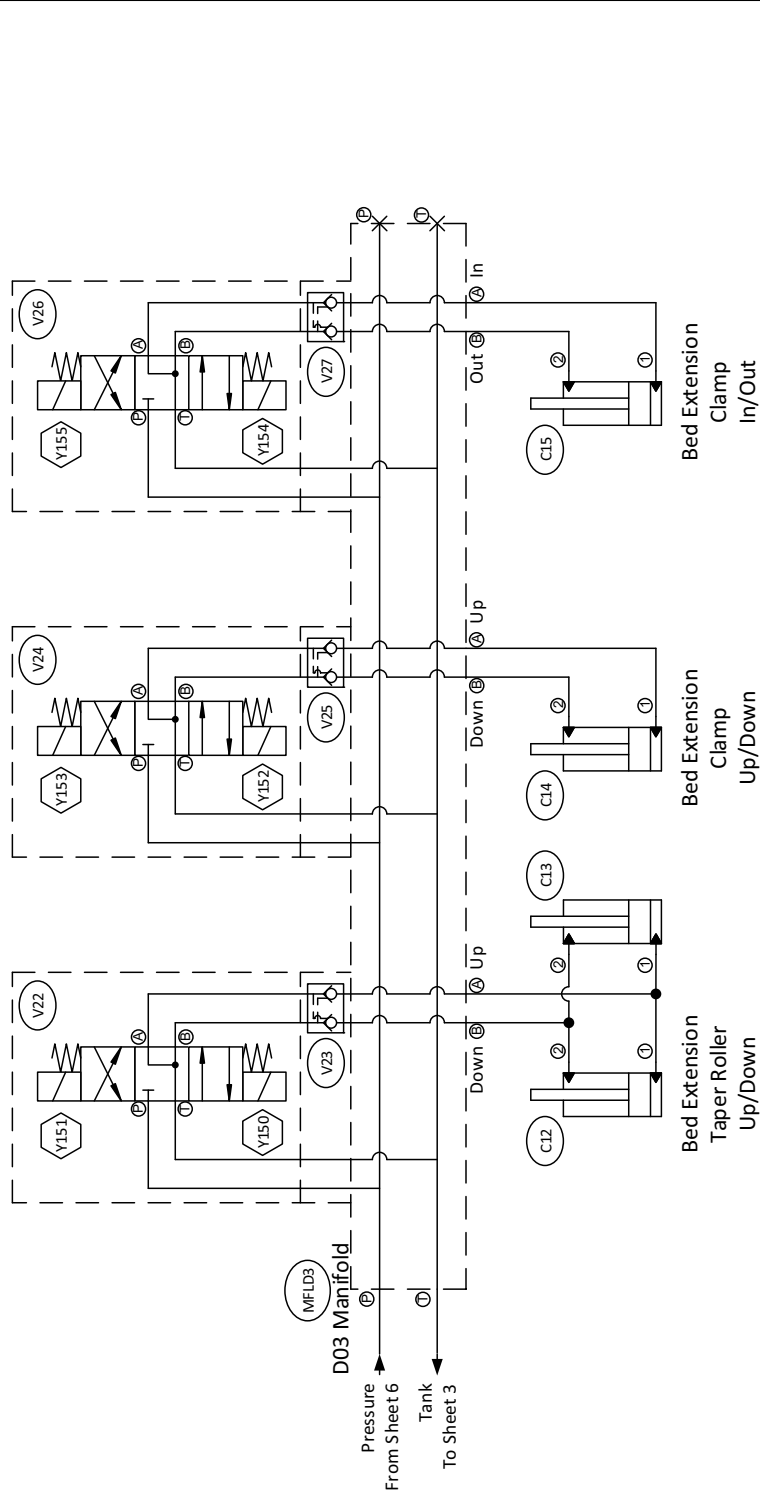
REV.	DESCRIPTION	DATE	BY
A1.00	Initial Release	7/2018	JRF
A2.00	Pull Down Clamps Addition	4/2019	JRF
A3.00	Double Bed/Error Corrections	9/2019	JRF





Wood-Mizer

DESCRIPTION

WM4500

SIZE	DATE	DWG NO	REV
A	7/2/2018	Hydraulic Schematics-BX12	A3.00

DRAWN	JRF	IN/MF	SHEET
Indianapolis, IN	Kolo, Poland		8 OF 22

REV.	DESCRIPTION	DATE	BY
A1.00	Initial Release	7/2018	JRF
A2.00	Pull Down Clamps Addition	4/2019	JRF
A3.00	Double Bed/Error Corrections	9/2019	JRF

Optional Hydraulic Bed Extension Turner Motor, Side Supports

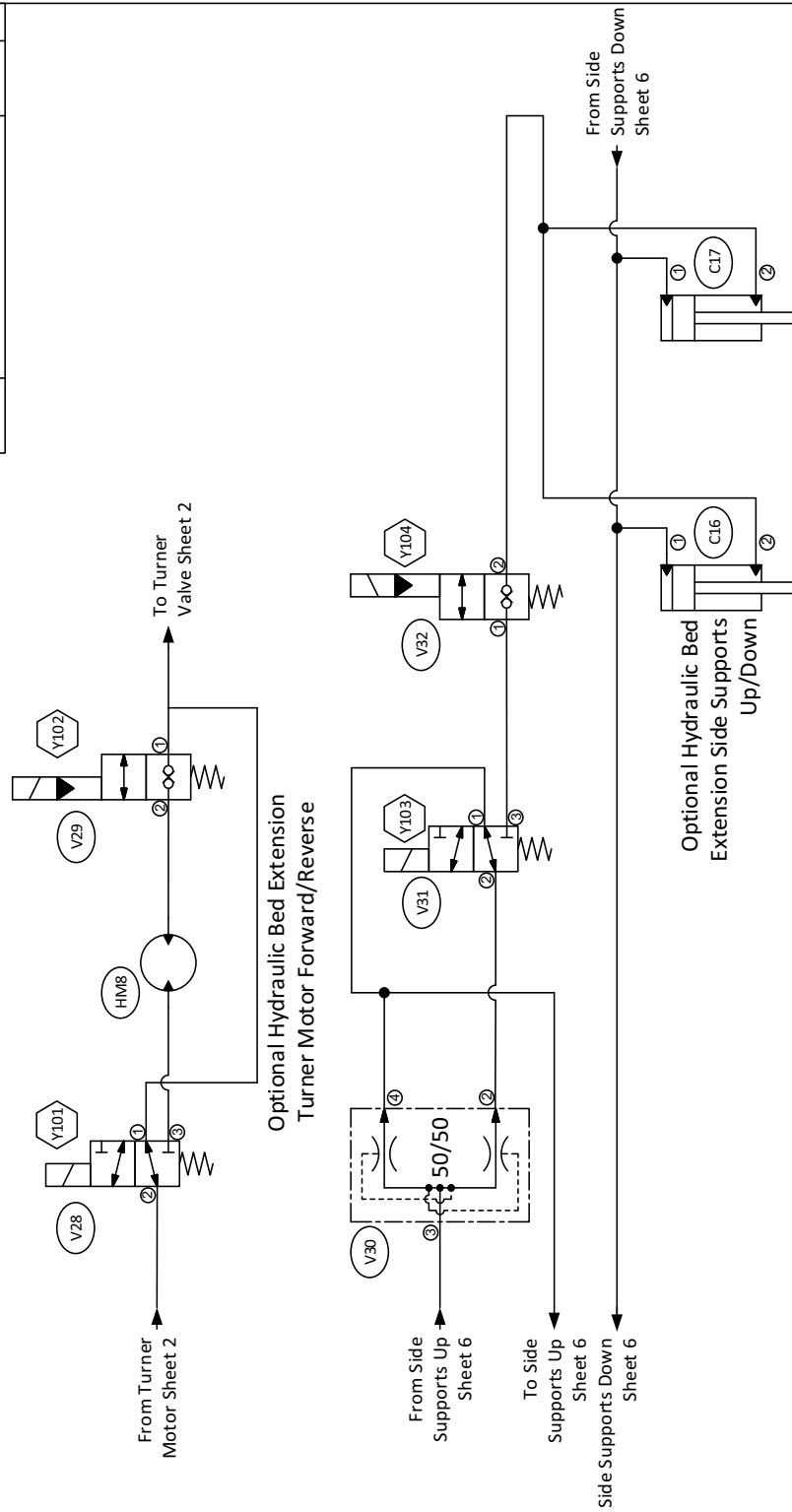

	DESCRIPTION		WM4500	
	SIZE	DATE	DWG NO	REV
A	7/2018	Hydraulic Schematics-BX12	A3.00	
INDIANAPOLIS, IN Kolo, Poland	DRAWN	JRF	INMF	SHEET
				9 OF 22



REV.	DESCRIPTION	DATE	BY
A1.00	Initial Release	7/2018	JRF
A2.00	Pull Down Clamps Addition	4/2019	JRF
A3.00	Double Bed/Error Corrections	9/2019	JRF

Optional Hydraulic Bed Extension Turner Up/Down, Power Taper Rollers

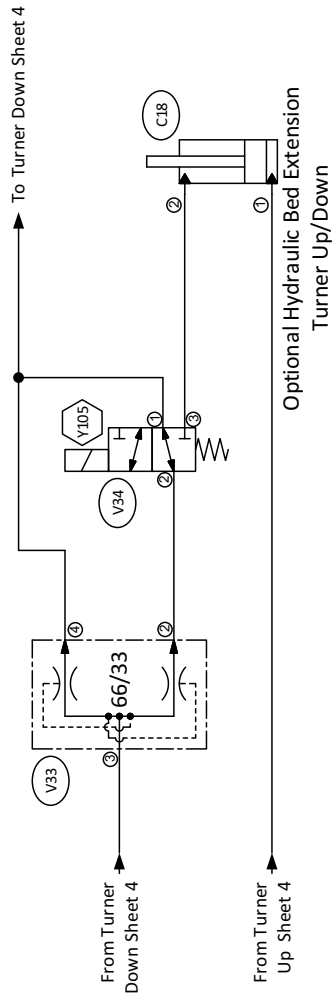

Optional Hydraulic Bed Extension
Turner Up/Down

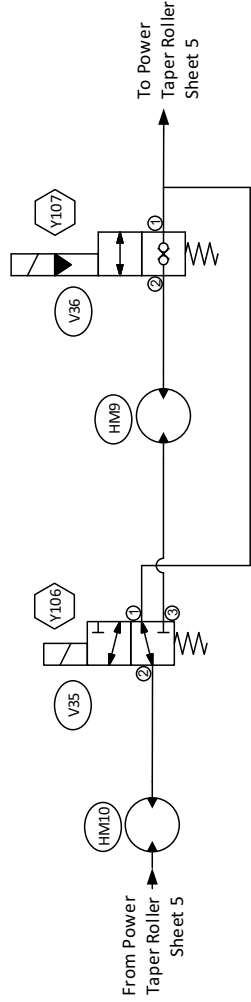

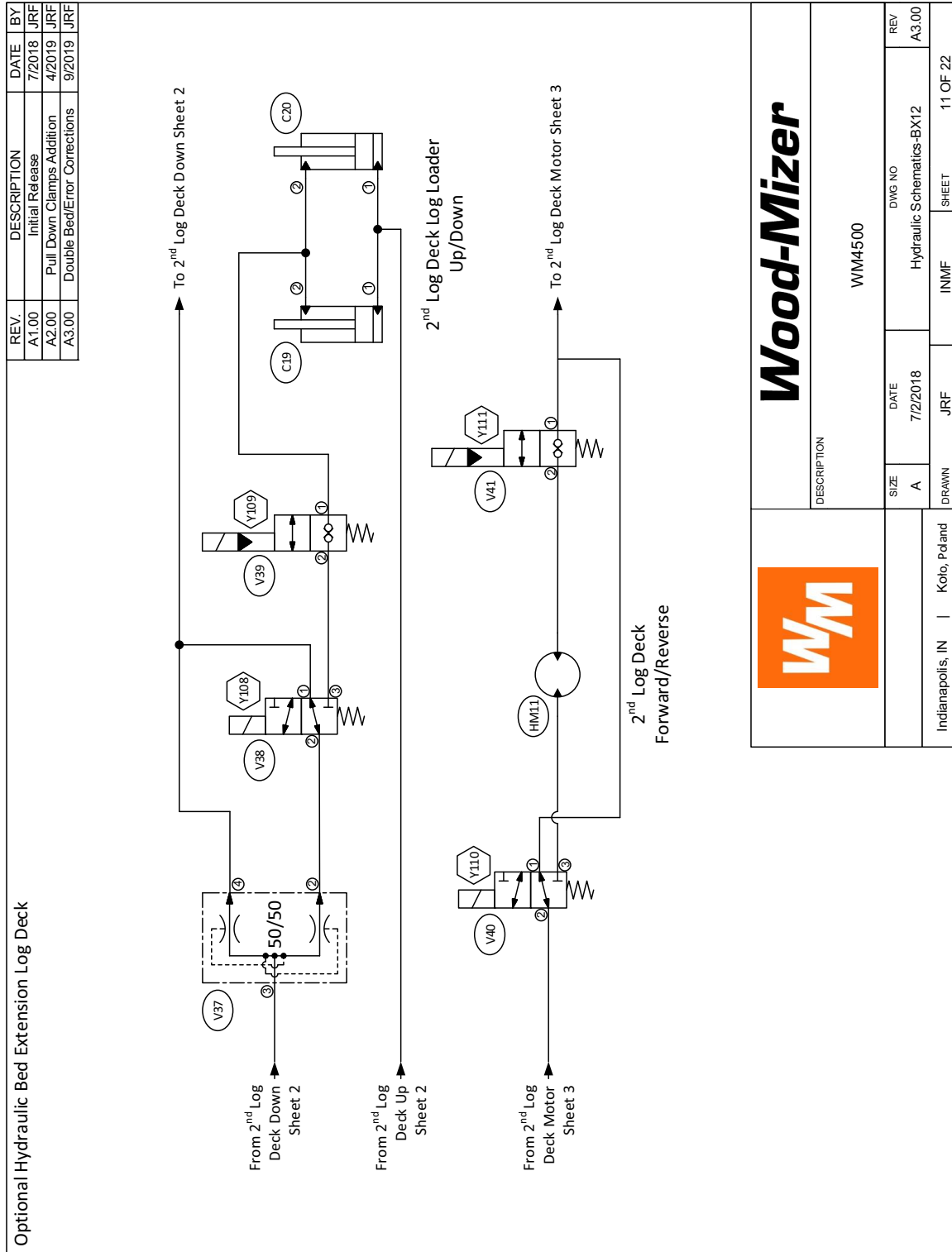

Optional Hydraulic Bed Extension
Power Taper Rollers Forward/Reverse

		DESCRIPTION		WM4500	
		SIZE	DATE	DWG NO	REV
Indianapolis, IN Kolo, Poland		A	7/2018	Hydraulic Schematics-BX12	A3.00
		DRAWN	JRF	INMF	SHEET
					10 OF 22

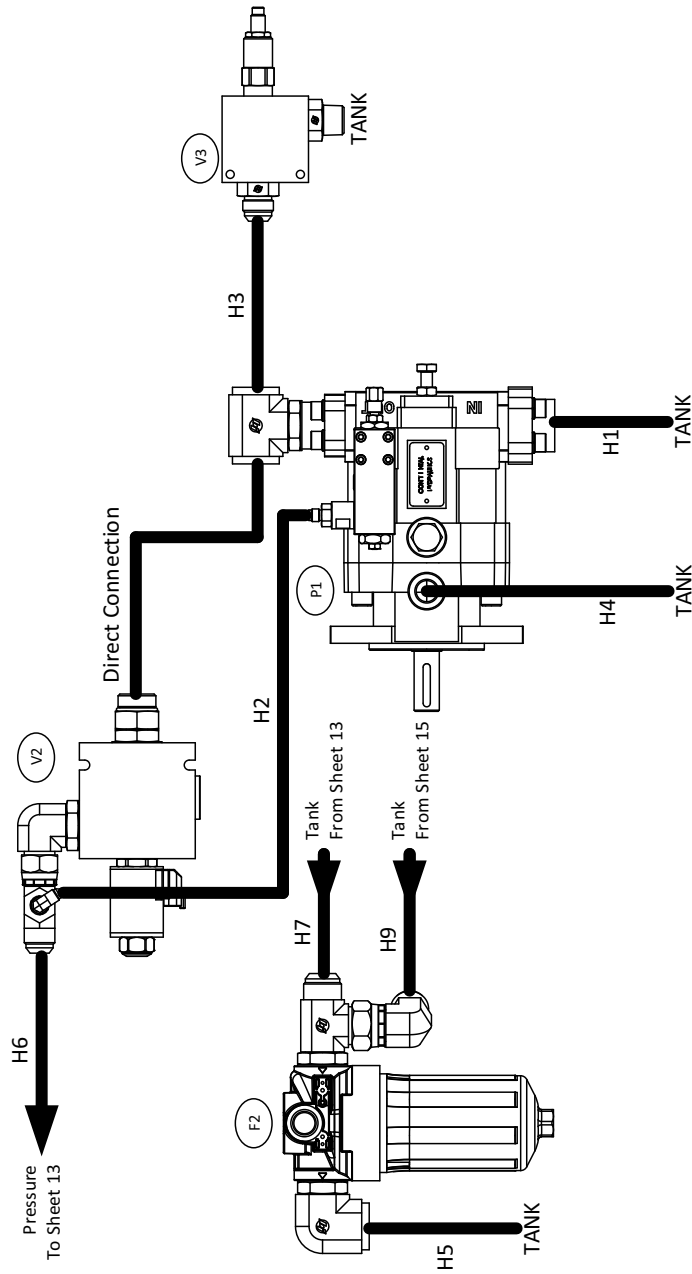

REV.	DESCRIPTION	DATE	BY
A1.00	Initial Release	7/2018	JRF
A2.00	Pull Down Clamps Addition	4/2019	JRF
A3.00	Double Bed/Error Corrections	9/2019	JRF



		DESCRIPTION	
		WM4500	
SIZE	DATE	DWG NO	REV
A	7/2018	Hydraulic Schematics-BX12	A3.00
DRAWN	JRF	INMF	SHEET
Indianapolis, IN	Koto, Poland		12 OF 22

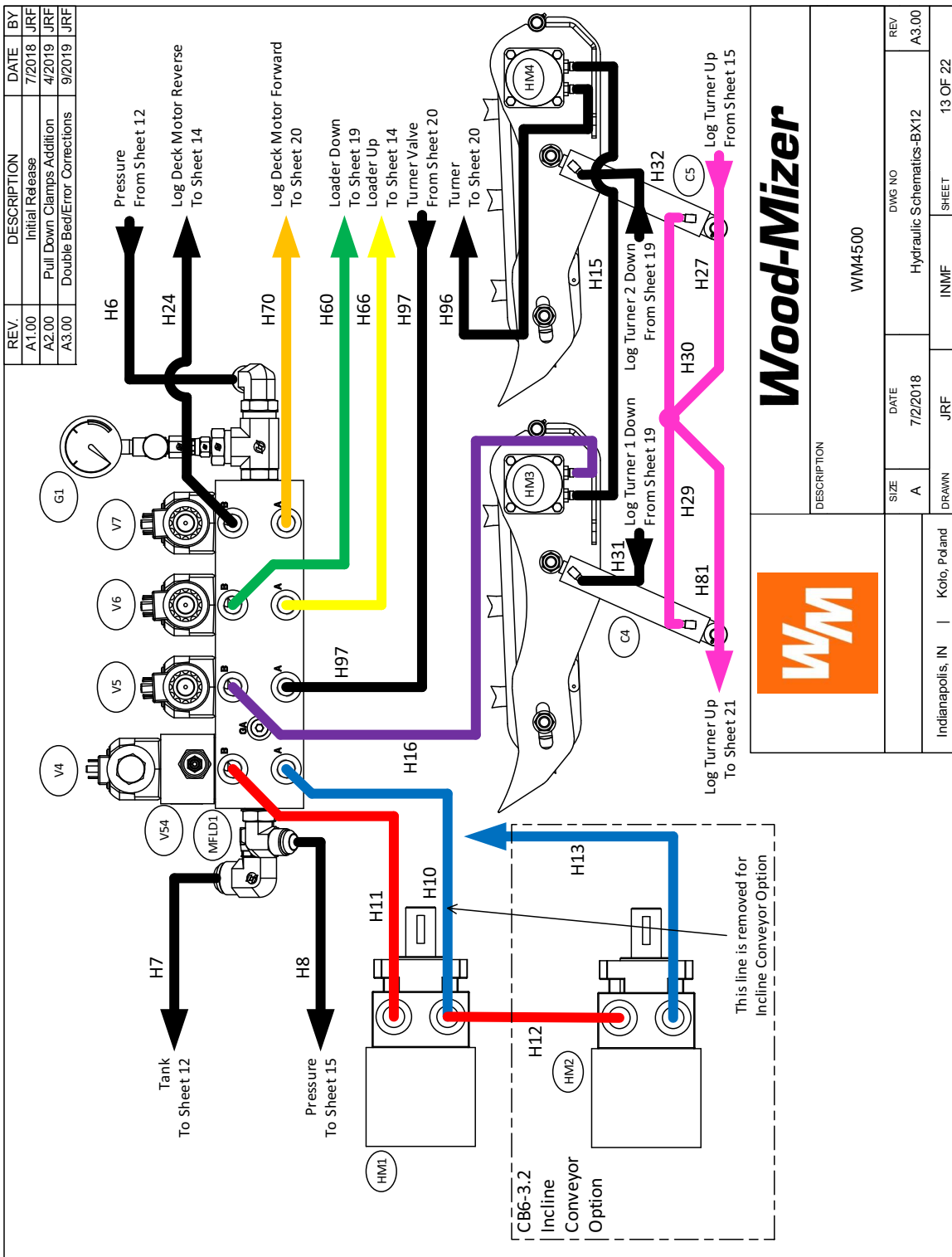

REV.	DESCRIPTION	DATE	BY
A1.00	Initial Release	7/2018	JRF
A2.00	Pull Down Clamps Addition	4/2019	JRF
A3.00	Double Bed/Error Corrections	9/2019	JRF

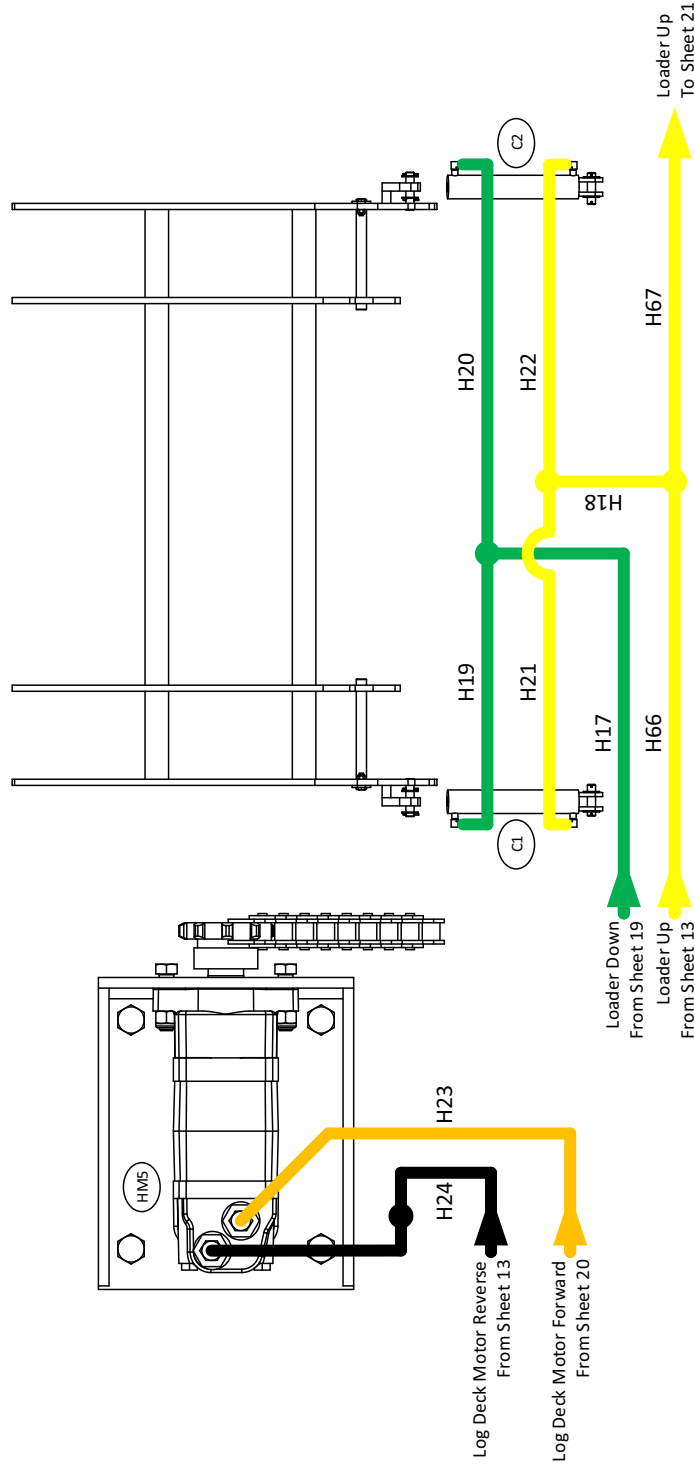

		DESCRIPTION	
		WM4500	
SIZE	DATE	DWG NO	REV
A	7/2/2018	Hydraulic Schematics-BX12	A3.00
DRAWN	JRF	INMF	SHEET
Indianapolis, IN	Koto, Poland		14 OF 22

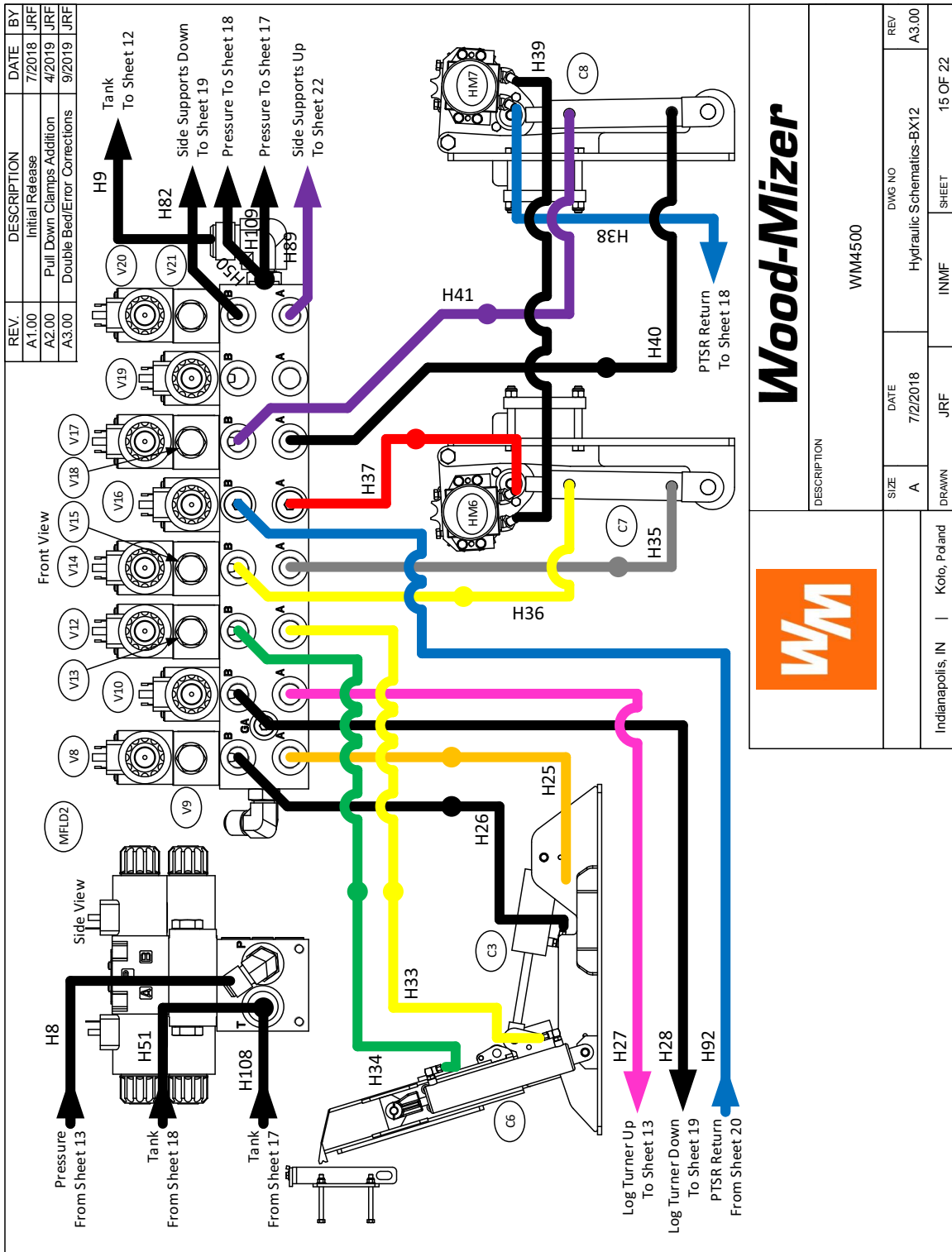

Wood-Mizer



DESCRIPTION		WM4500	
SIZE	DATE	DWG NO	REV
A	7/2018	Hydraulic Schematics-BX12	A3.00
DRAWN	JRF	INMF	SHEET
Indianapolis, IN	Kolo, Poland		15 OF 22

REV.	DESCRIPTION	DATE	BY
A1.00	Initial Release	7/2018	JRF
A2.00	Pull Down Clamps Addition	4/2019	JRF
A3.00	Double Bed/Error Corrections	9/2019	JRF

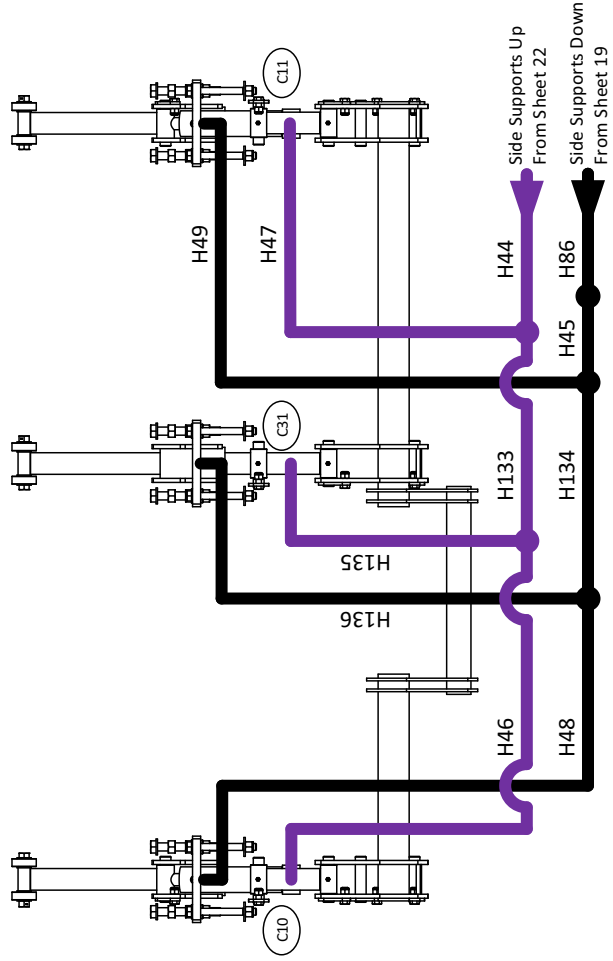

Wood-Mizer



DESCRIPTION		WM4500	
SIZE	DATE	DWG NO	REV
A	7/2/2018	Hydraulic Schematics-BX12	A3.00
DRAWN	JRF	IN/MF	SHEET
Indianapolis, IN	Koto, Poland		16 OF 22

REV.	DESCRIPTION	DATE	BY
A1.00	Initial Release	7/2018	JRF
A2.00	Pull Down Clamps Addition	4/2019	JRF
A3.00	Double Bed/Error Corrections	9/2019	JRF

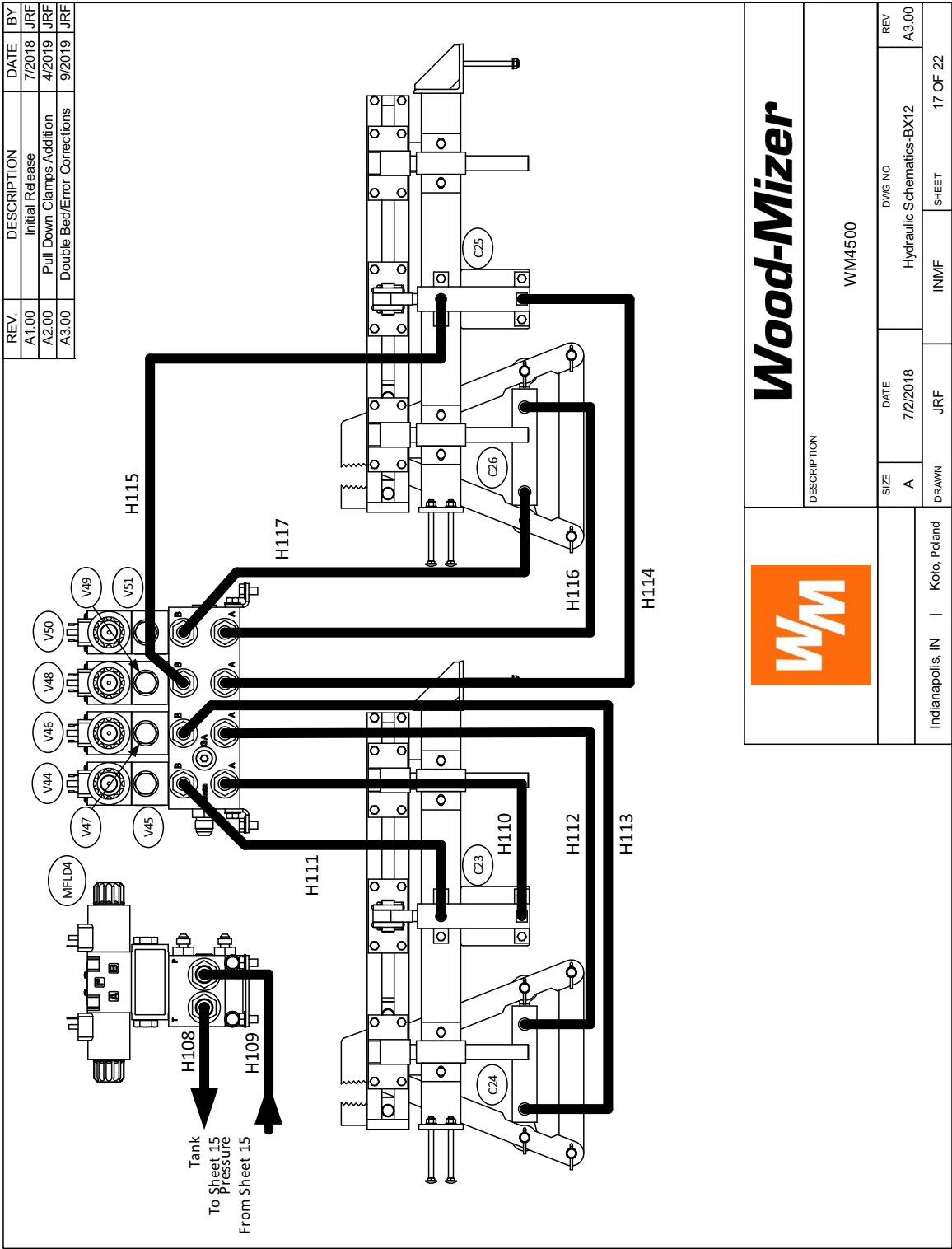

Wood-Mizer

DESCRIPTION

WM4500

SIZE	DATE	DWG NO	REV
A	7/2/2018	Hydraulic Schematics-BX12	A3.00

DRAWN	JRF	IN/MF	SHEET
Indianapolis, IN	Kolo, Poland		17 OF 22



8 Hydraulic Information

Hydraulic Schematics BX12

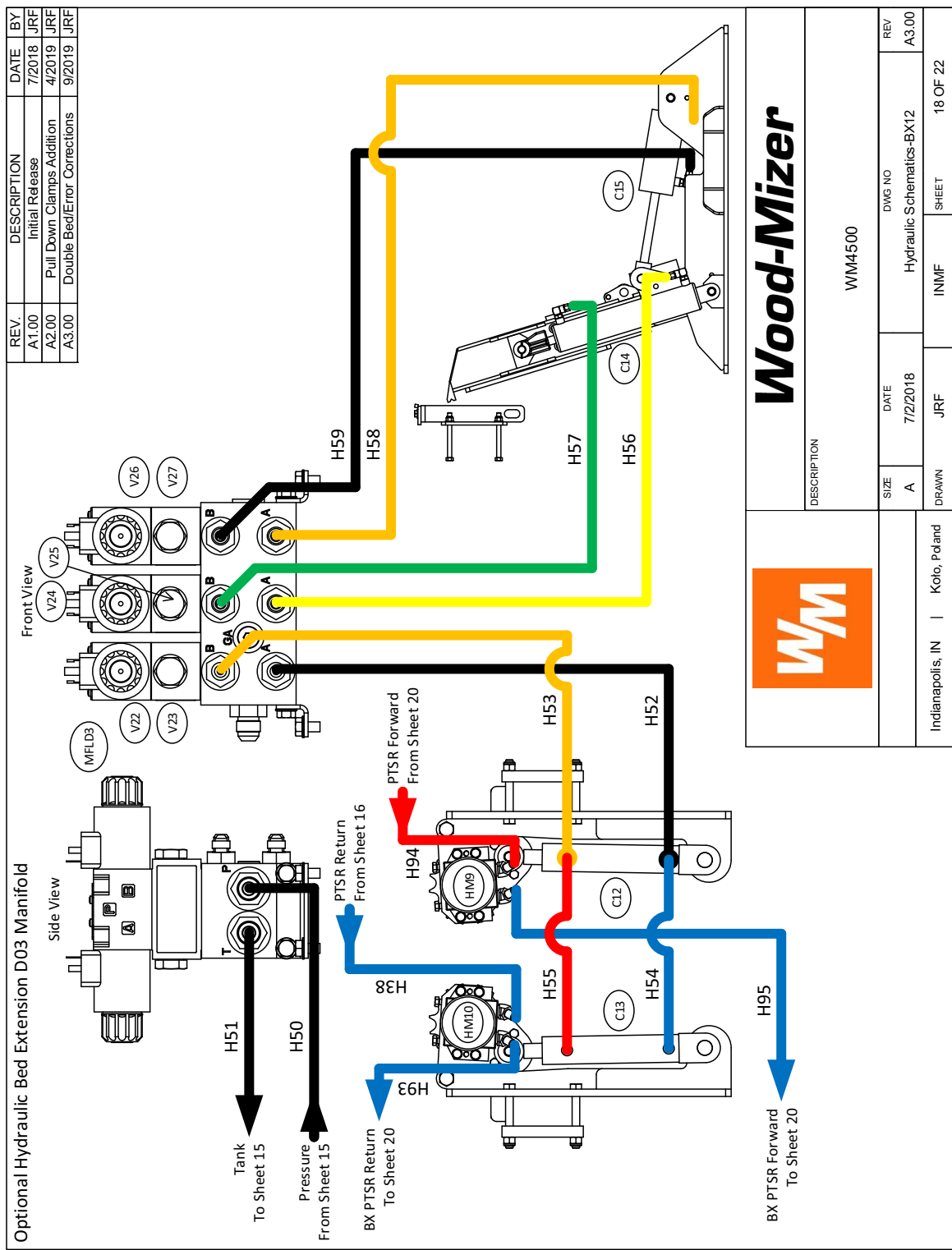

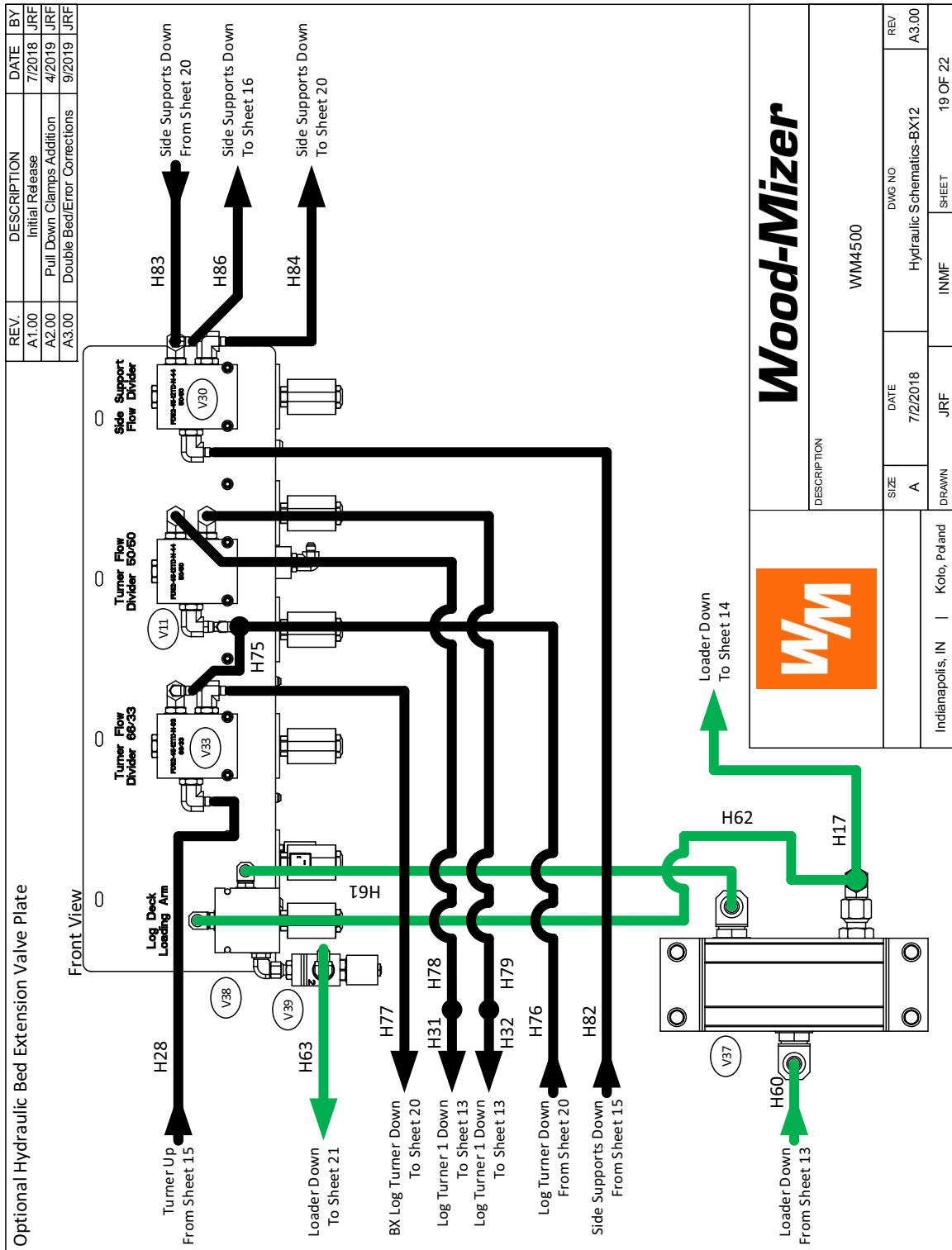

Hydraulic Information

Hydraulic Schematics BX12

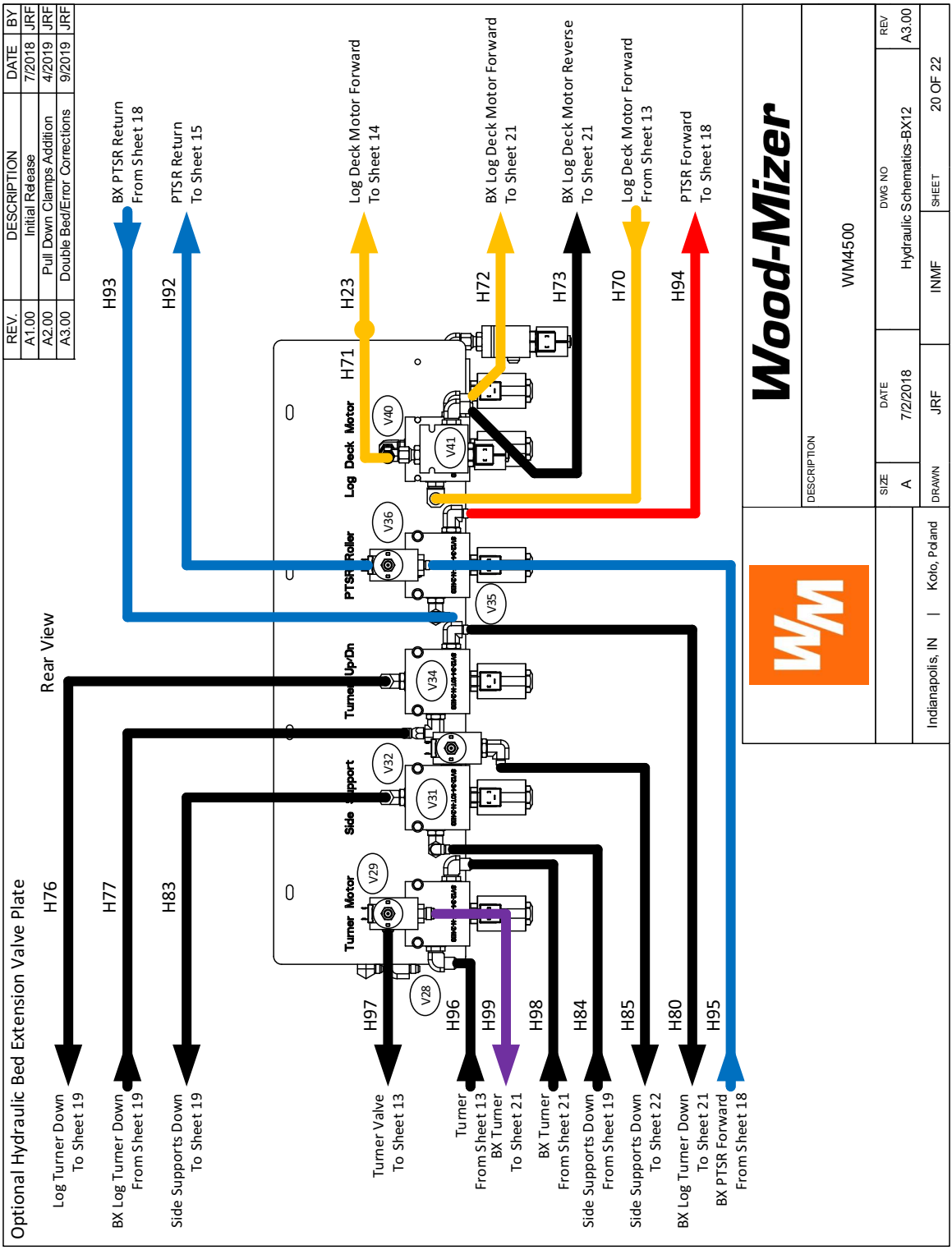

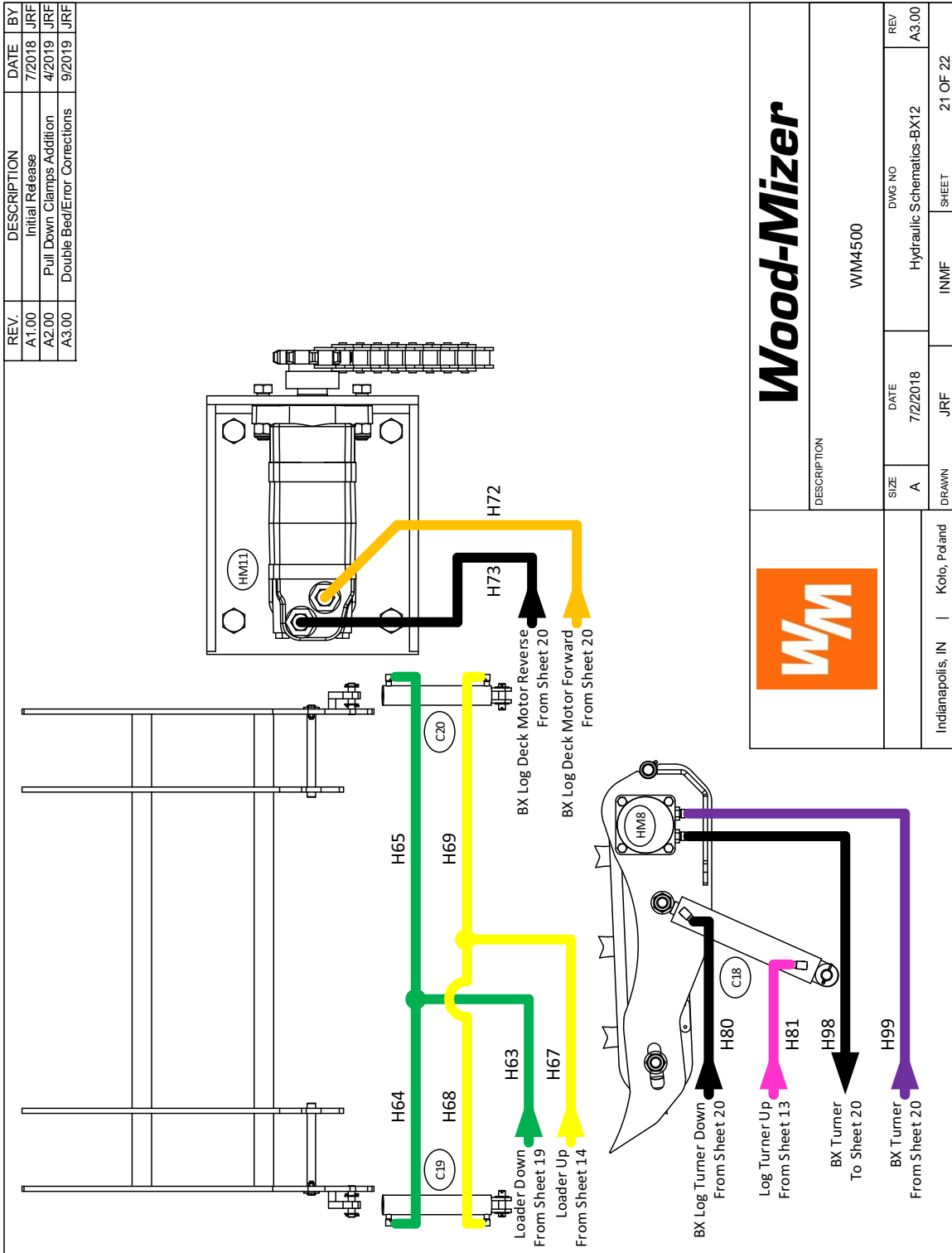

REV	DESCRIPTION	DATE	BY
A1.00	Initial Release	7/2018	JRF
A2.00	Pull Down Clamps Addition	4/2019	JRF
A3.00	Double Bed/Error Corrections	9/2019	JRF

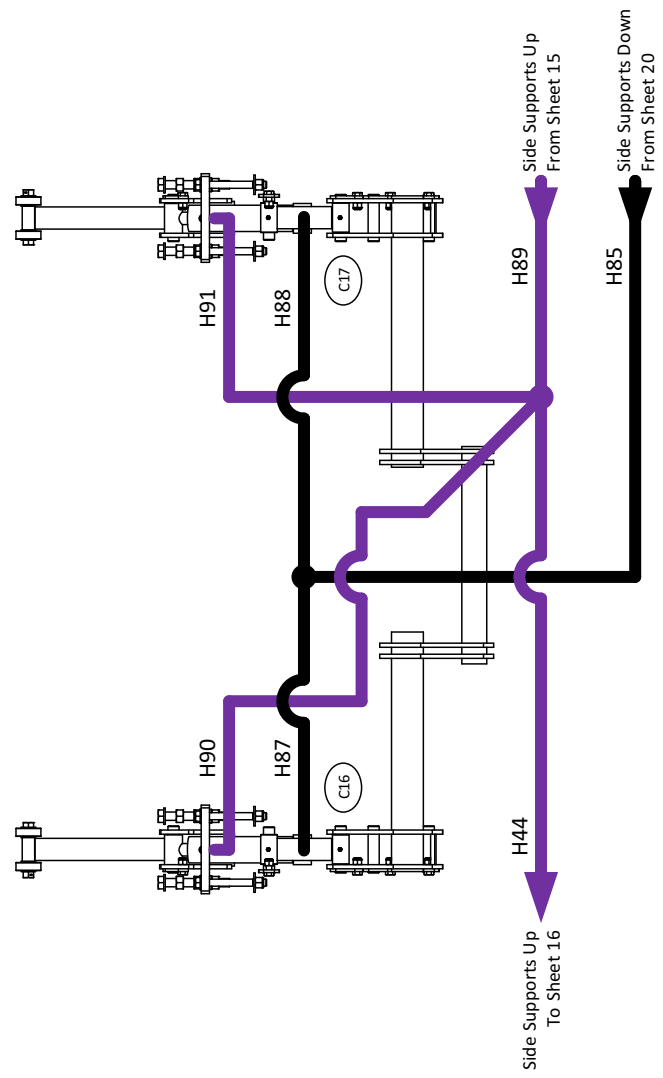

		DESCRIPTION	
		WM4500	
SIZE	DATE	DWG NO	REV
A	7/2/2018	Hydraulic Schematics-BX12	A3.00
DRAWN	JRF	INMF	SHEET
Indianapolis, IN	Kolo, Poland		22 OF 22

8.3 Hydraulic Schematics Double Bed

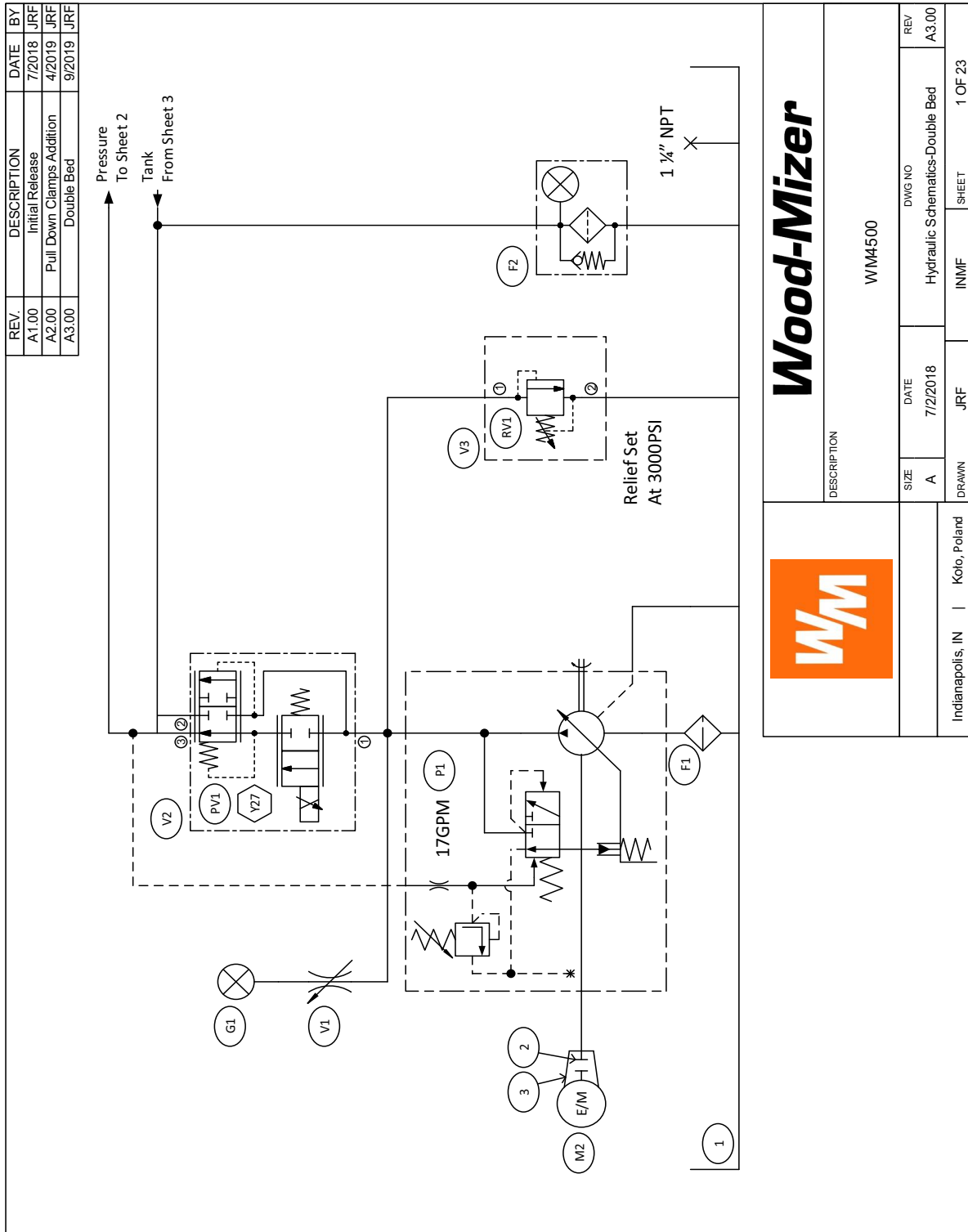

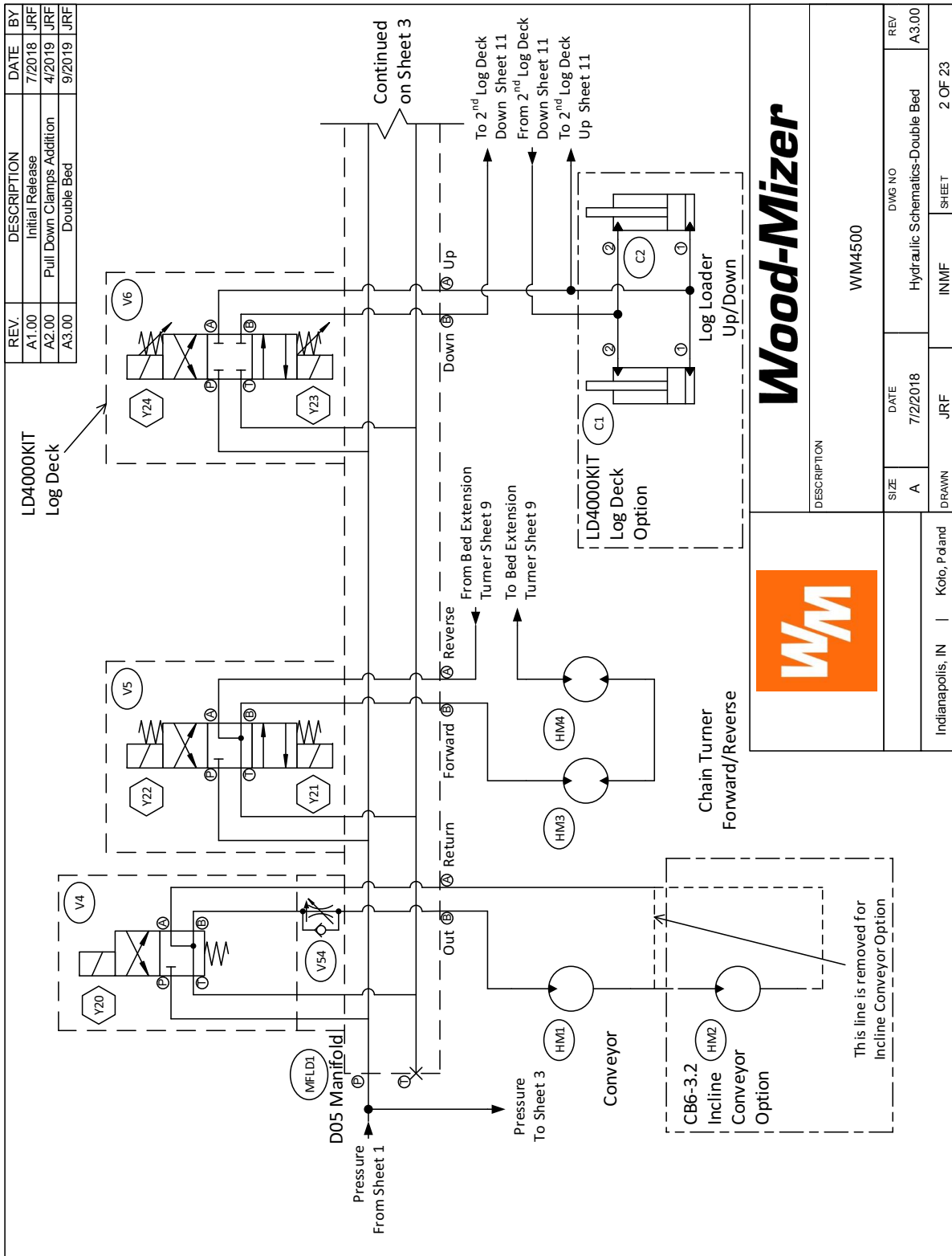

REV.	DESCRIPTION	DATE	BY
A1.00	Initial Release	7/2018	JRF
A2.00	Pull Down Clamps Addition	4/2019	JRF
A3.00	Double Bed	9/2019	JRF

Wood-Mizer



DESCRIPTION		WM4500	
SIZE	DATE	DWG NO	REV
A	7/2/2018	Hydraulic Schematics-Double Bed	A3.00
DRAWN	JRF	INMF	SHEET
Indianapolis, IN	Kolo, Poland		2 OF 23

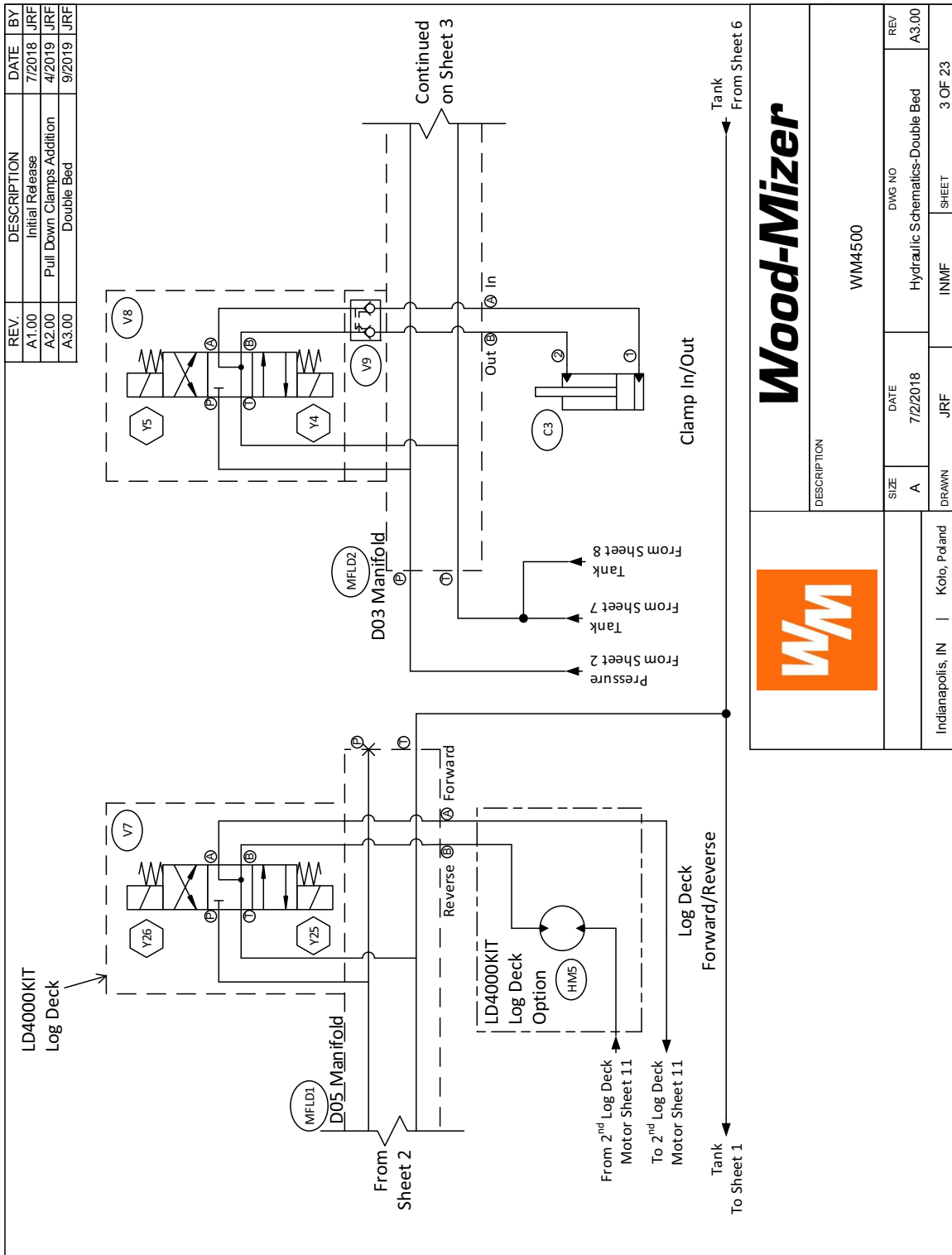

	Wood-Mizer		
	DESCRIPTION WM4500		
SIZE A	DATE 7/2/2018	DWG NO Hydraulic Schematics-Double Bed	REV A3.00
DRAWN Kolo, Poland	JRF	INMIF	SHEET 3 OF 23

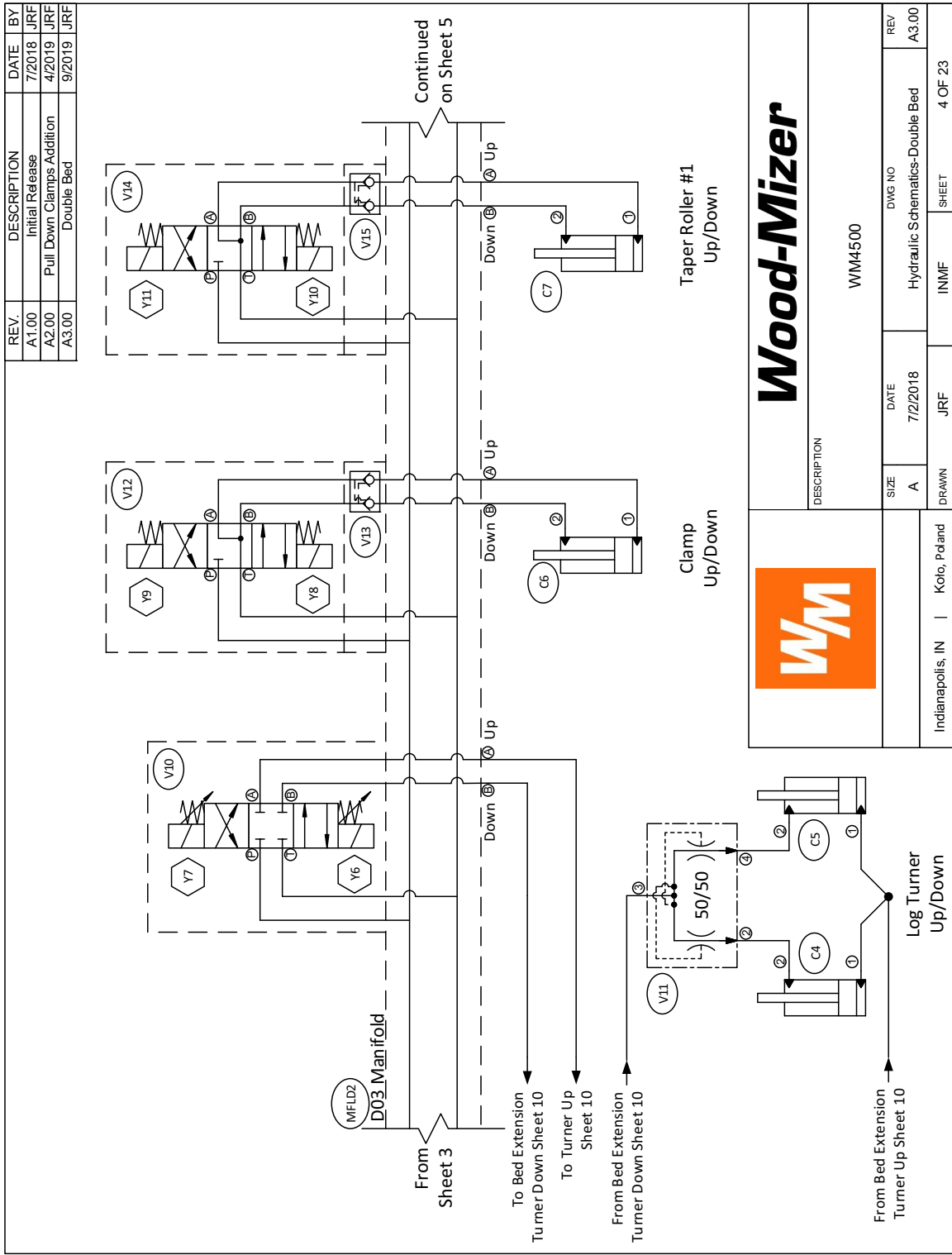

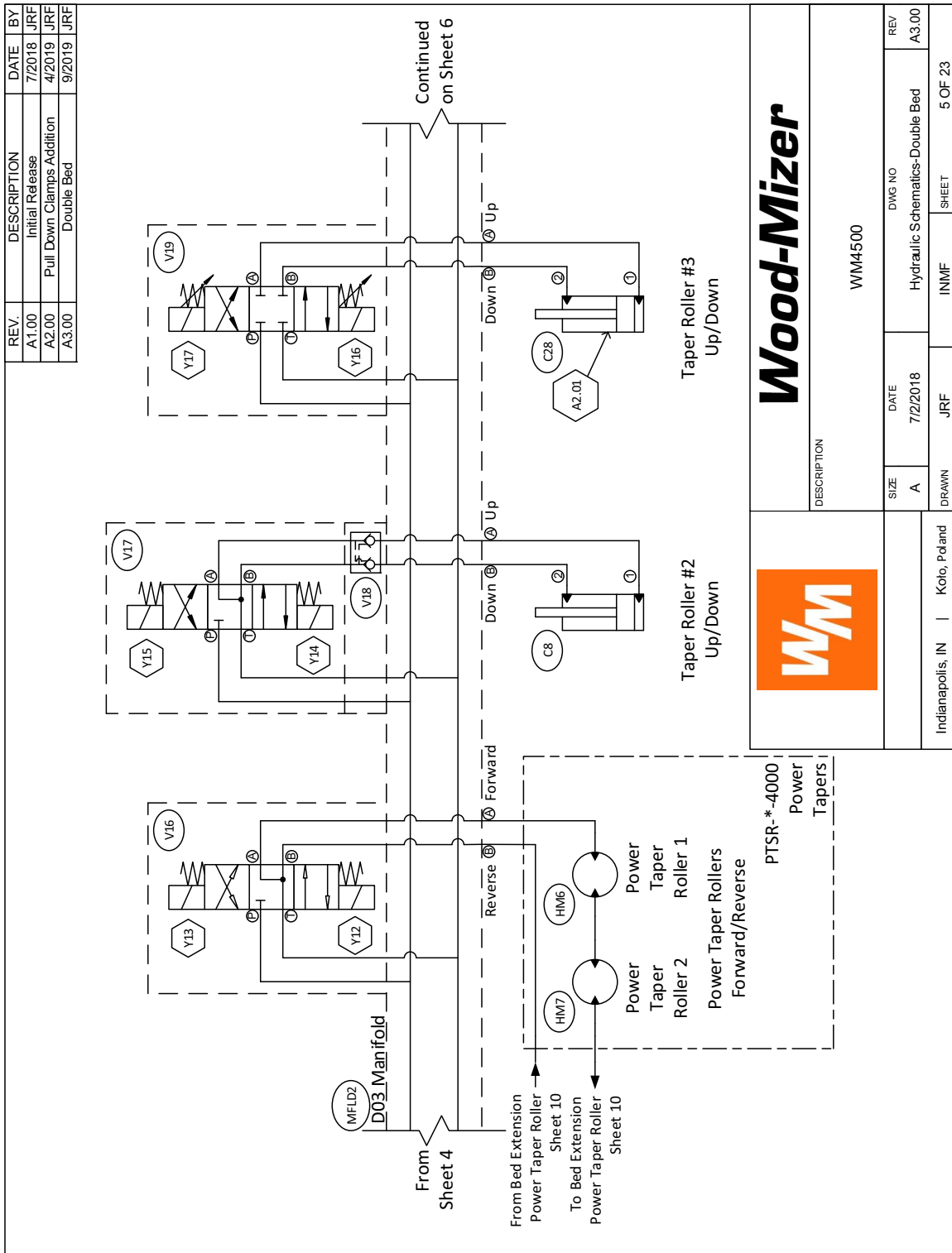





Hydraulic Information

Hydraulic Schematics Double Bed

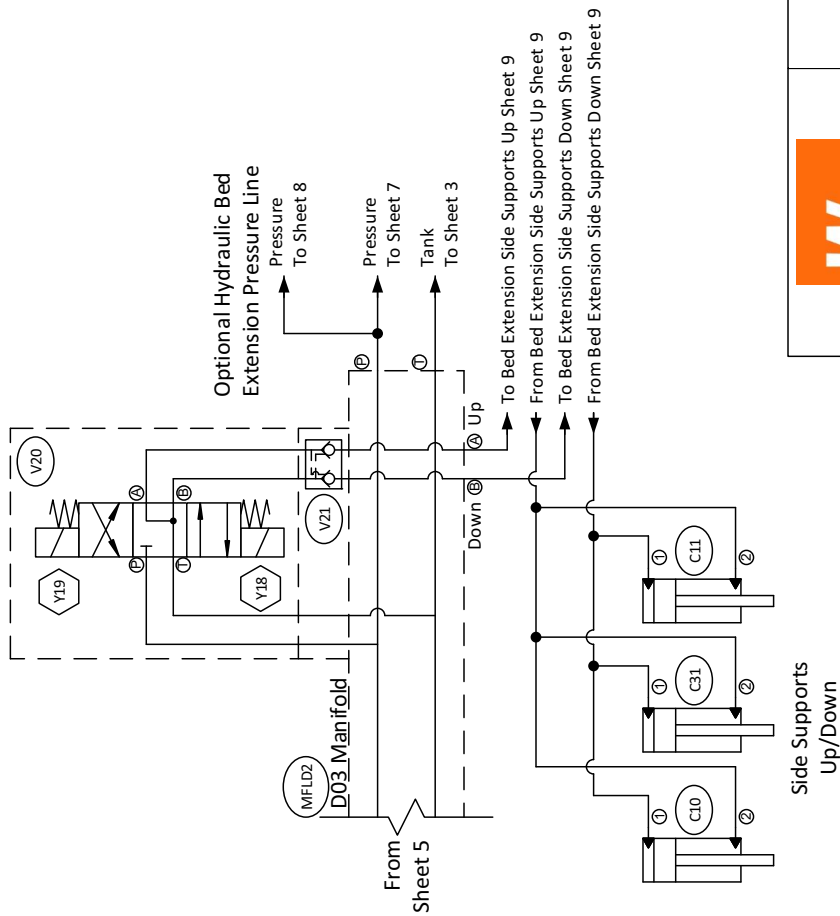
REV.	DESCRIPTION	DATE	BY
A1.00	Initial Release	7/2018	JRF
A2.00	Pull Down Clamps Addition	4/2019	JRF
A3.00	Double Bed	9/2019	JRF



		DESCRIPTION	
		WM4500	
SIZE	DATE	DWG NO	REV
A	7/2018	Hydraulic Schematics-Double Bed	A3.00
DRAWN	JRF	INMF	SHEET
Indianapolis, IN	Kolo, Poland		6 OF 23

REV.	DESCRIPTION	DATE	BY
A1.00	Initial Release	7/2018	JRF
A2.00	Pull Down Clamps Addition	4/2019	JRF
A3.00	Double Bed	9/2019	JRF

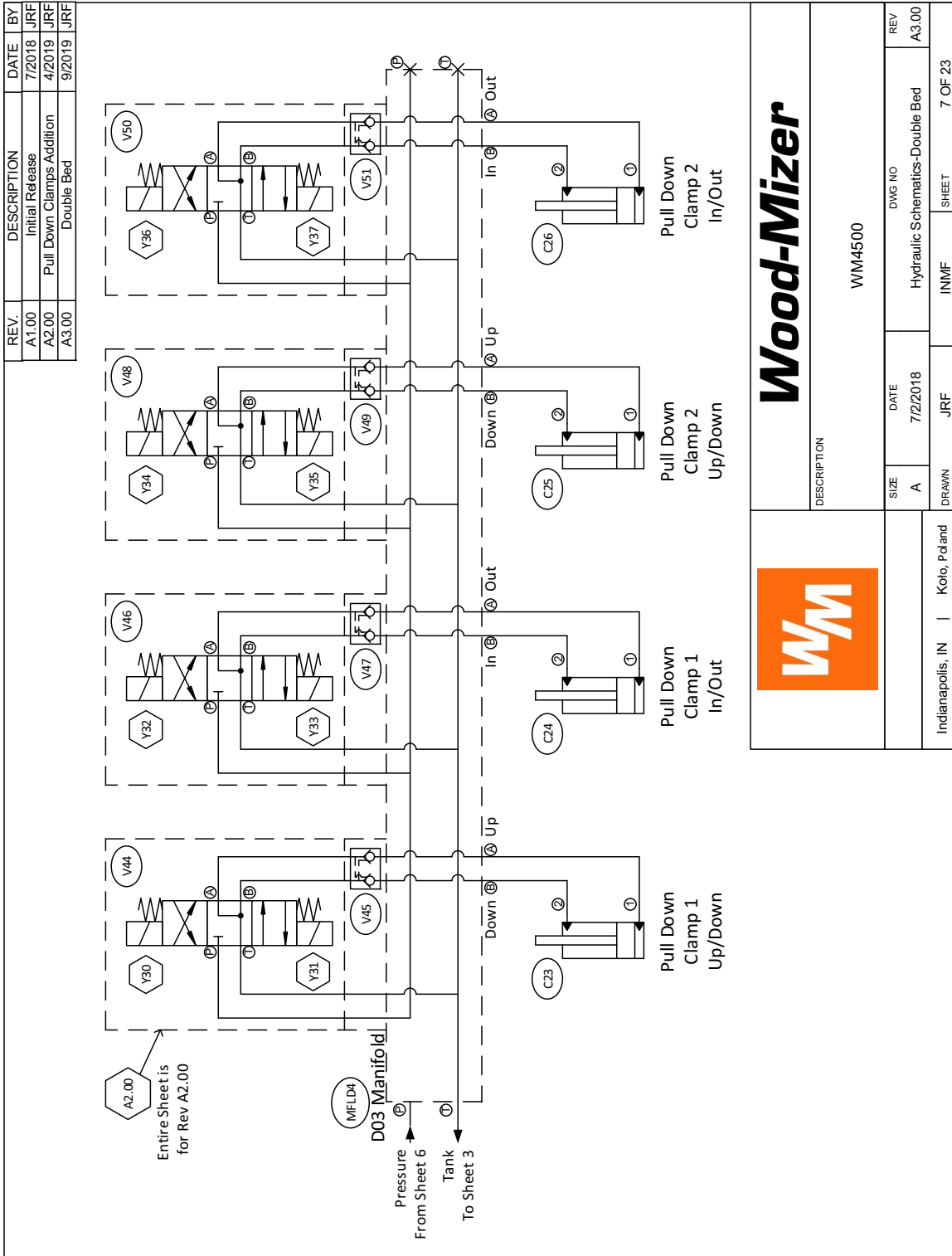

Wood-Mizer



DESCRIPTION

WM4500

SIZE	DATE	DWG NO	REV
A	7/2/2018	Hydraulic Schematics-Double Bed	A3.00
DRAWN	JRF	INMF	SHEET
Indianapolis, IN	Kolo, Poland		7 OF 23



Hydraulic Information

Hydraulic Schematics Double Bed

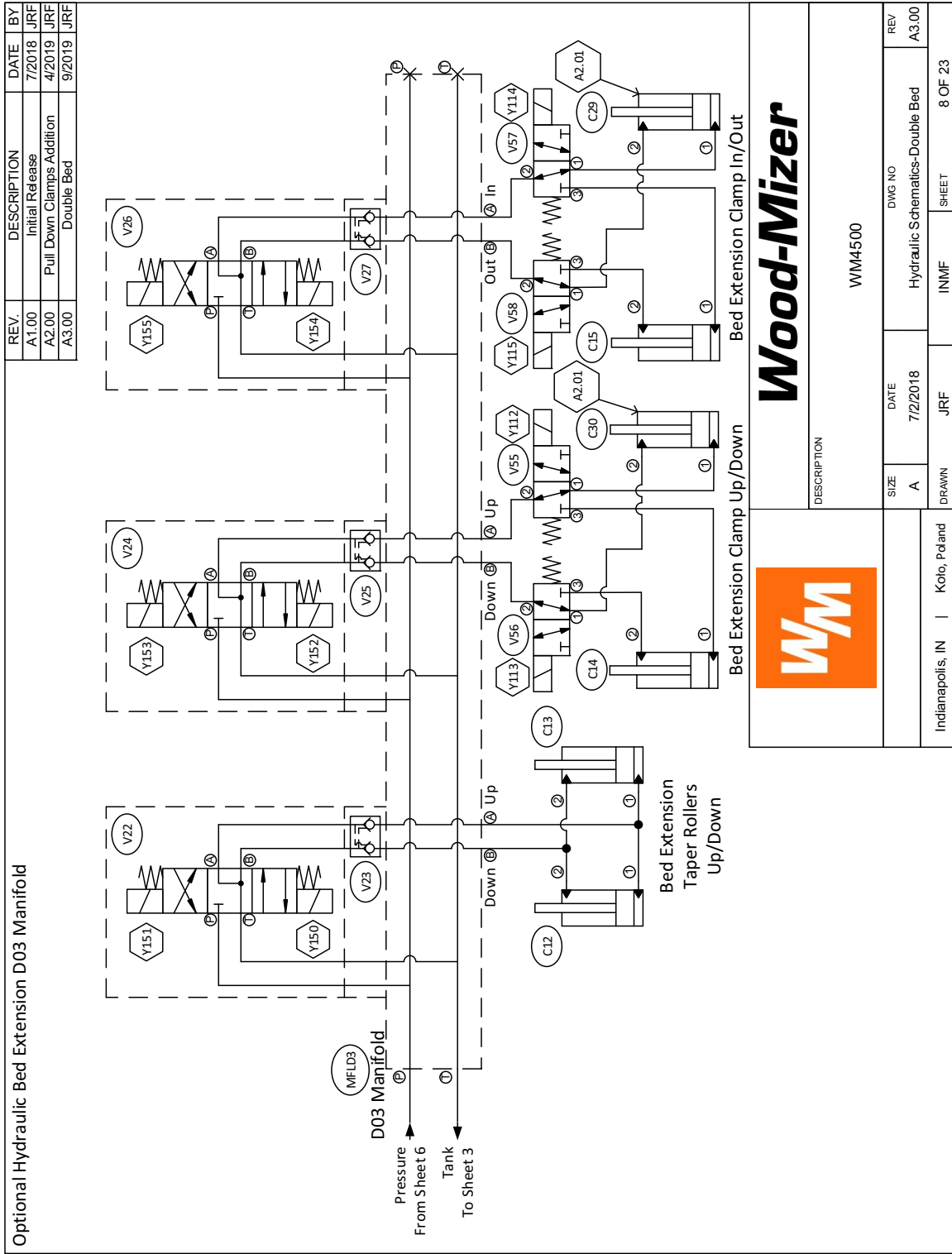

Wood-Mizer



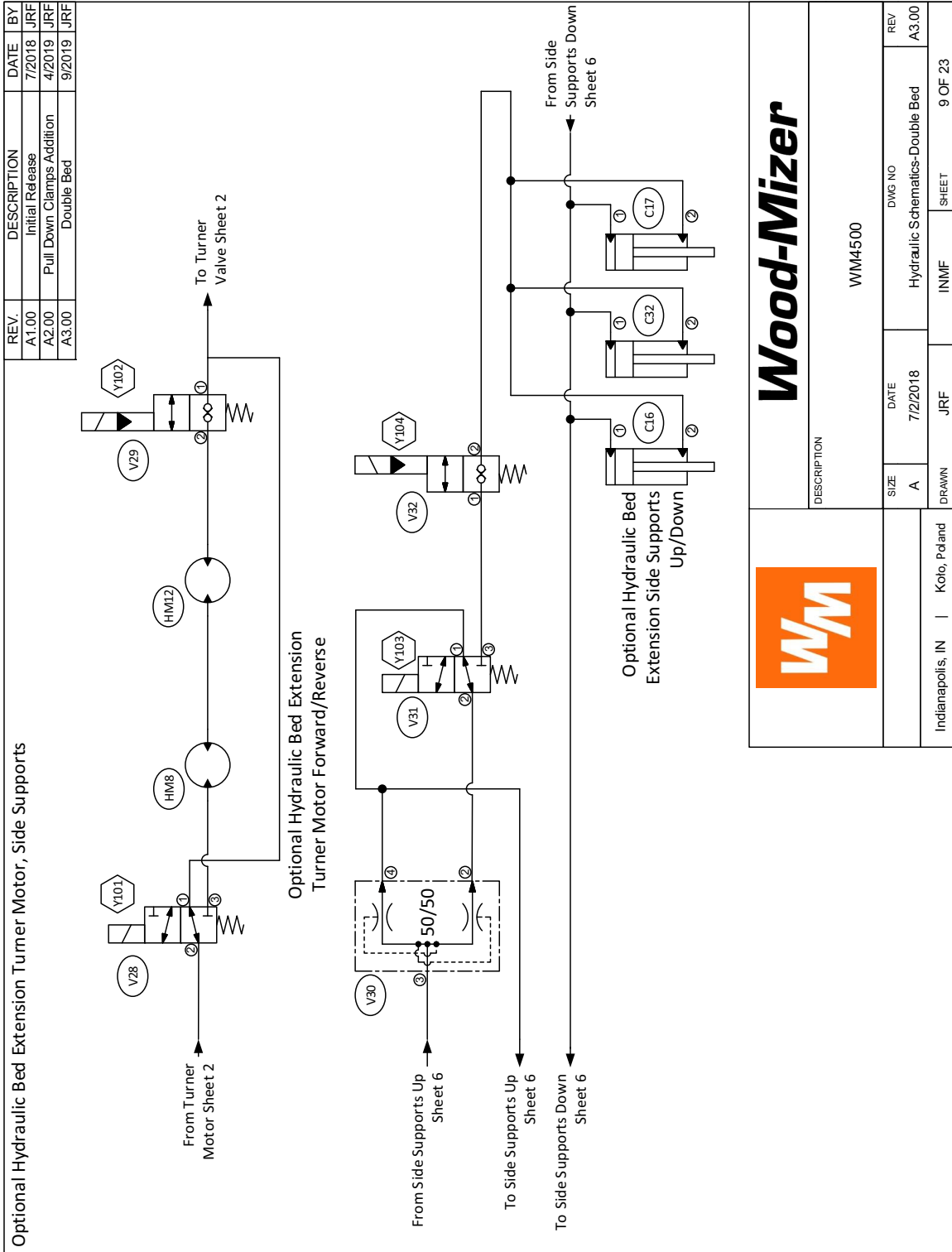

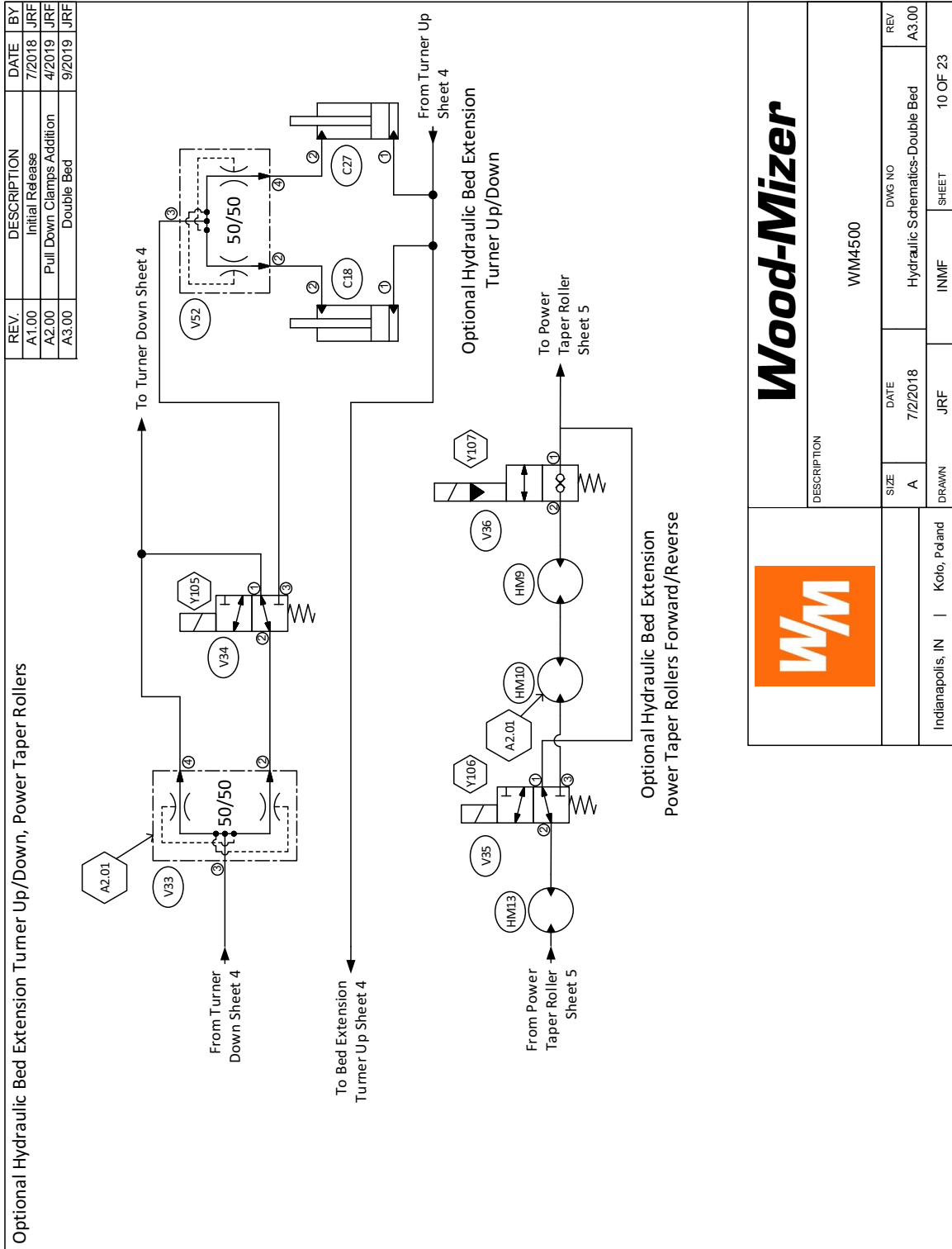



8 Hydraulic Information

Hydraulic Schematics Double Bed

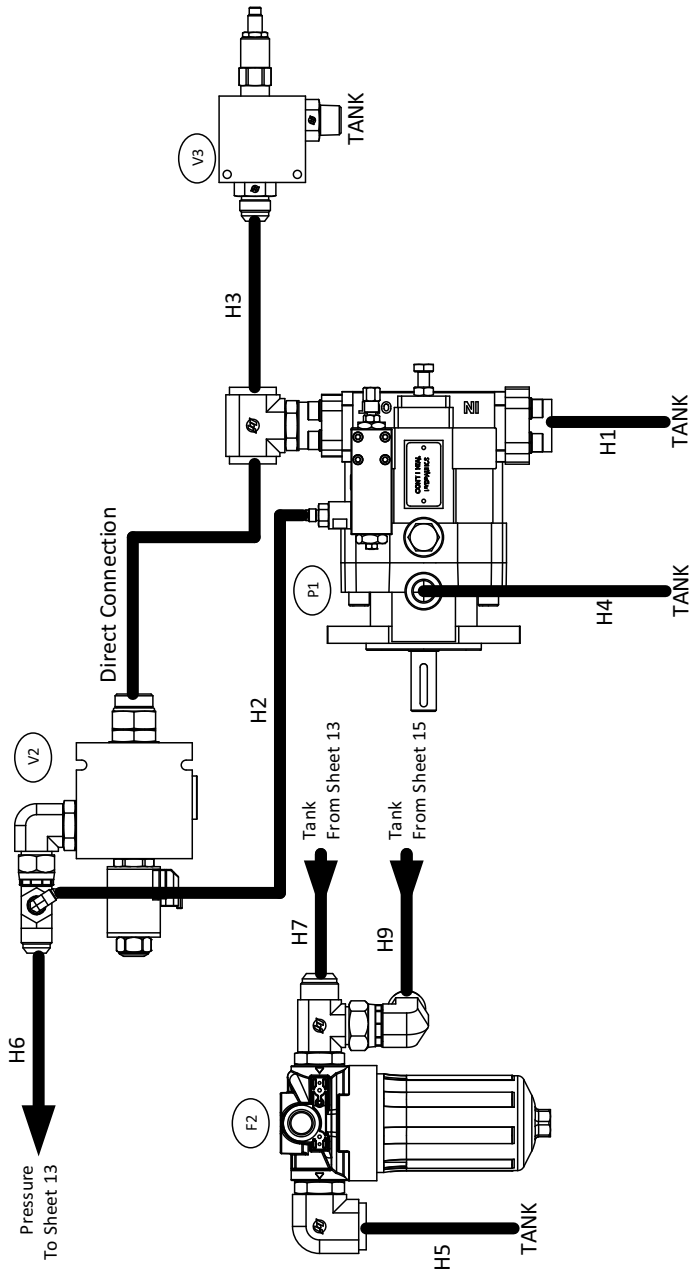
REV.	DESCRIPTION	DATE	BY
A1.00	Initial Release	7/2018	JRF
A2.00	Pull Down Clamps Addition	4/2019	JRF
A3.00	Double Bed	9/2019	JRF



		DESCRIPTION	
		WM4500	
SIZE	DATE	DWG NO	REV
A	7/2/2018	Hydraulic Schematics-Double Bed	A3.00
DRAWN	JRF	INMF	SHEET
Indianapolis, IN	Koro, Pd and		12 OF 23

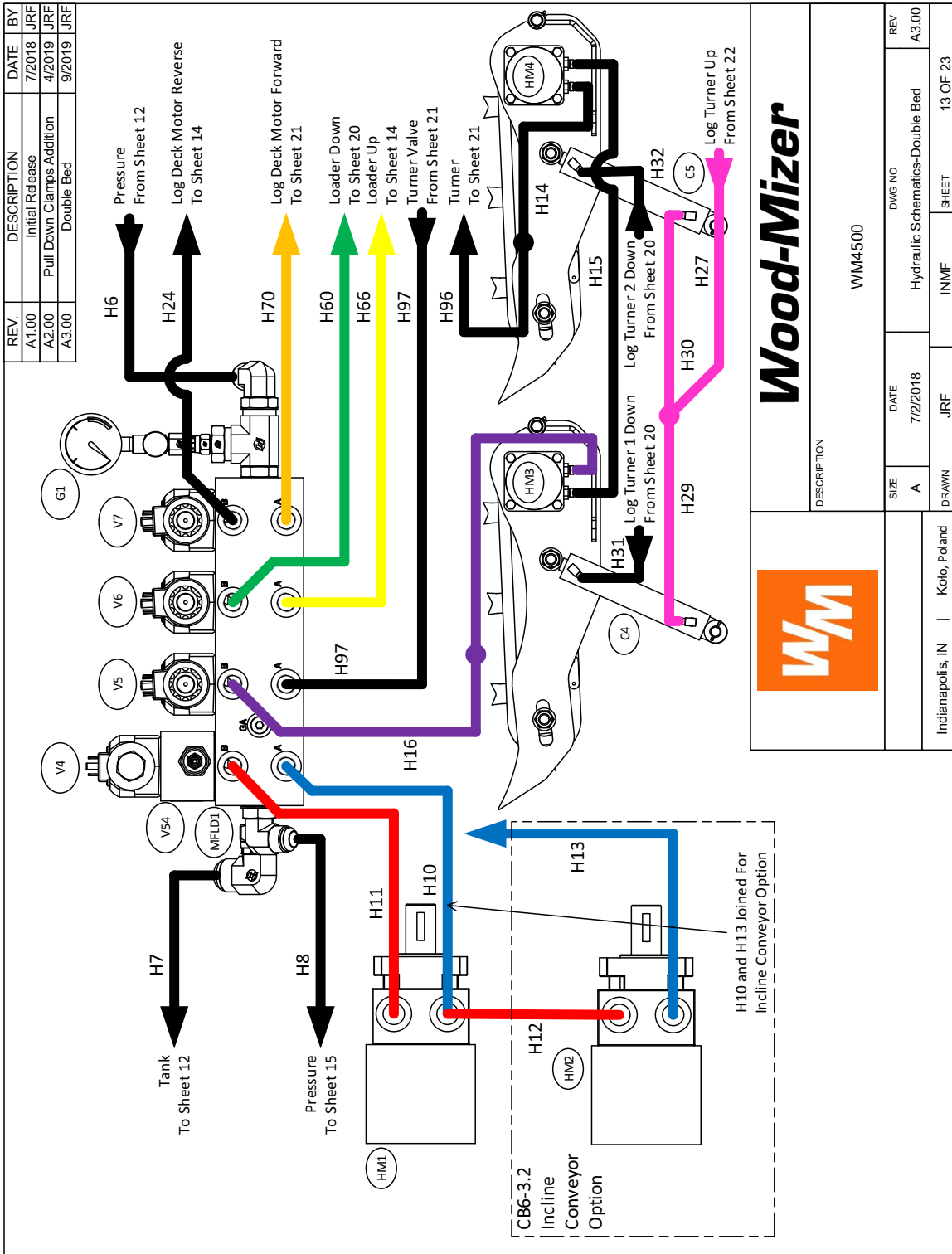

REV.	DESCRIPTION	DATE	BY
A1.00	Initial Release	7/2018	JRF
A2.00	Pull Down Clamps Addition	4/2019	JRF
A3.00	Double Bed	9/2019	JRF

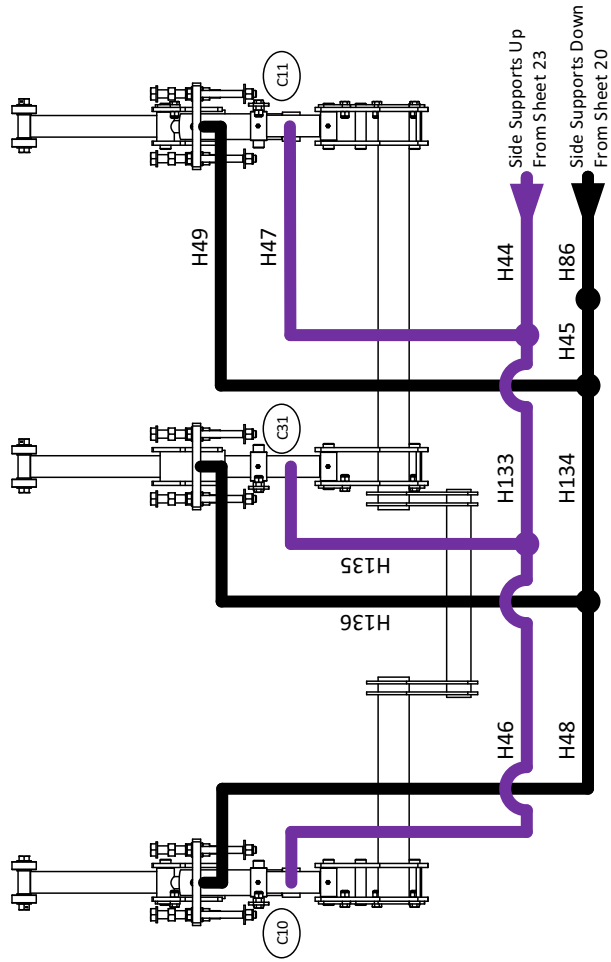

Wood-Mizer



DESCRIPTION	
WM4500	
SIZE	DATE
A	7/2/2018
DRAWN	JRF
INDIANAPOLIS, IN	Koro, Pd and
DWG NO	REV
Hydraulic Schematics-Double Bed	A3.00
SHEET	16 OF 23

REV.	DESCRIPTION	DATE	BY
A1.00	Initial Release	7/2018	JRF
A2.00	Pull Down Clamps Addition	4/2019	JRF
A3.00	Double Bed	9/2019	JRF

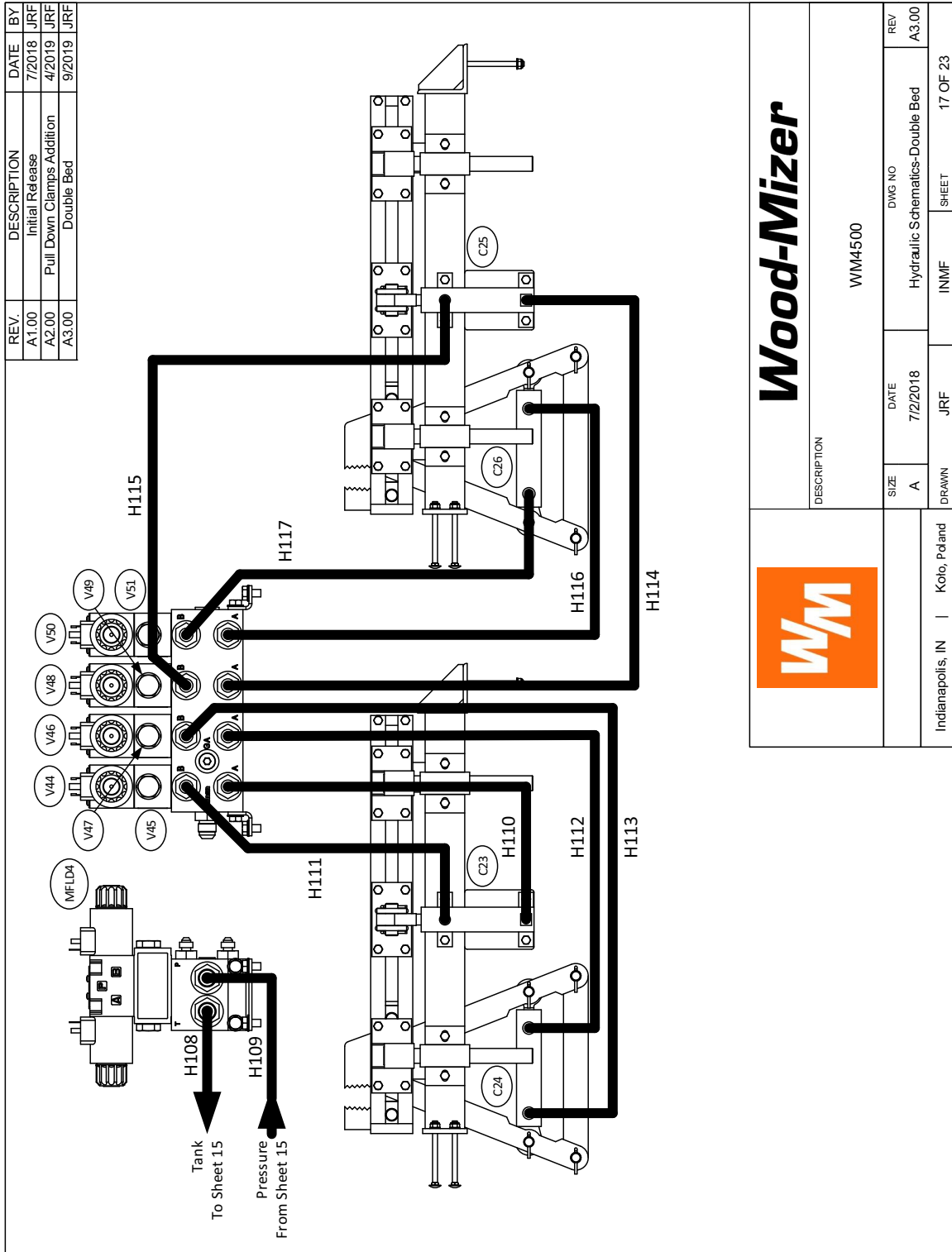

Wood-Mizer



DESCRIPTION	
WM4500	
SIZE	DATE
A	7/2018
DRAWN	JRF
INDIANAPOLIS, IN	Kolo, Poland
DWG NO	SHEET
Hydraulic Schematics-Double Bed	17 OF 23
REV	
A3.00	

8 Hydraulic Information

Hydraulic Schematics Double Bed

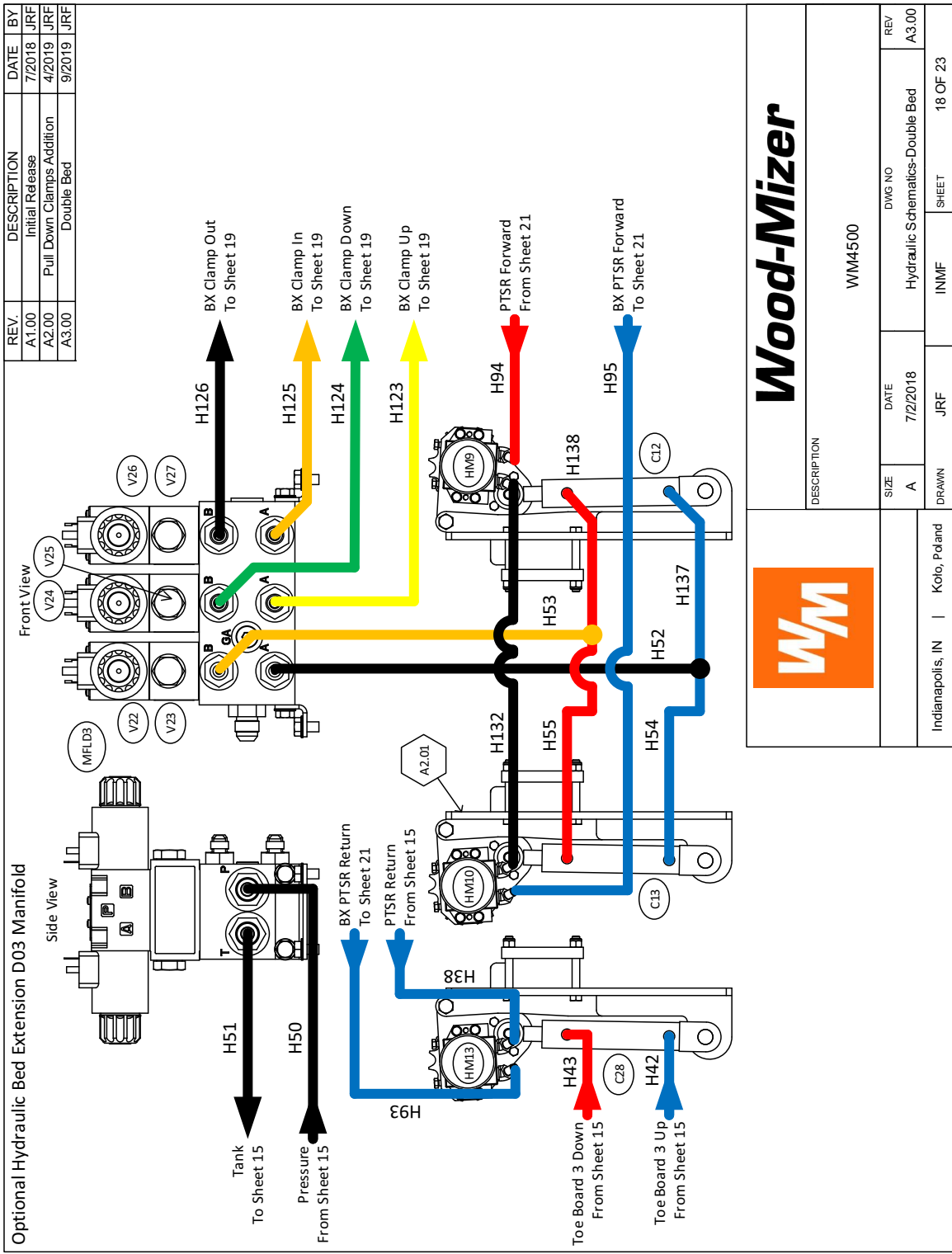

Wood-Mizer



DESCRIPTION	SIZE	DATE	DWG NO	REV
WM4500	A	7/2018	Hydraulic Schematics-Double Bed	A3.00
Indianapolis, IN Kolo, Poland	DRAWN	JRF	INMF	SHEET
				18 OF 23

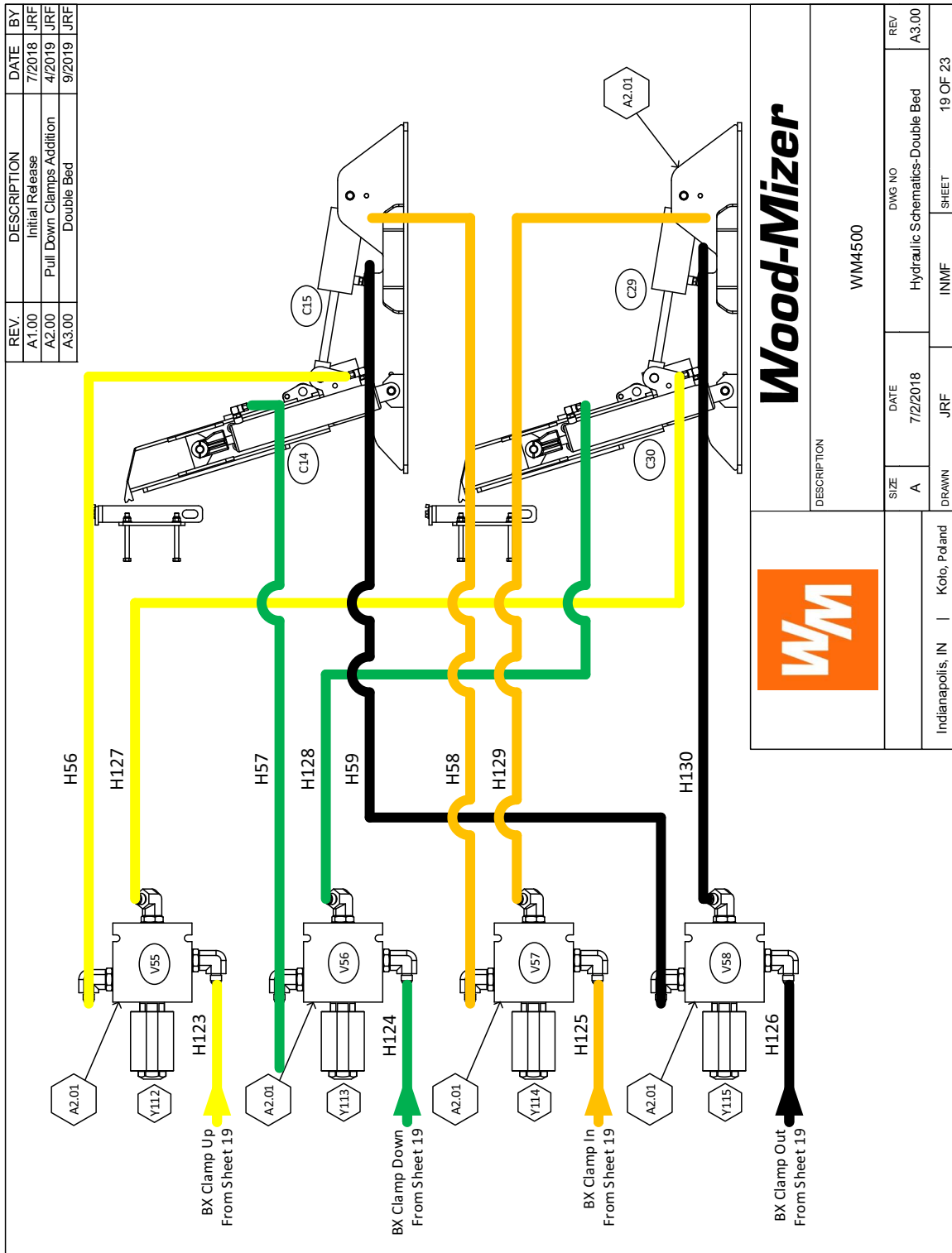

8 Hydraulic Information

Hydraulic Schematics Double Bed

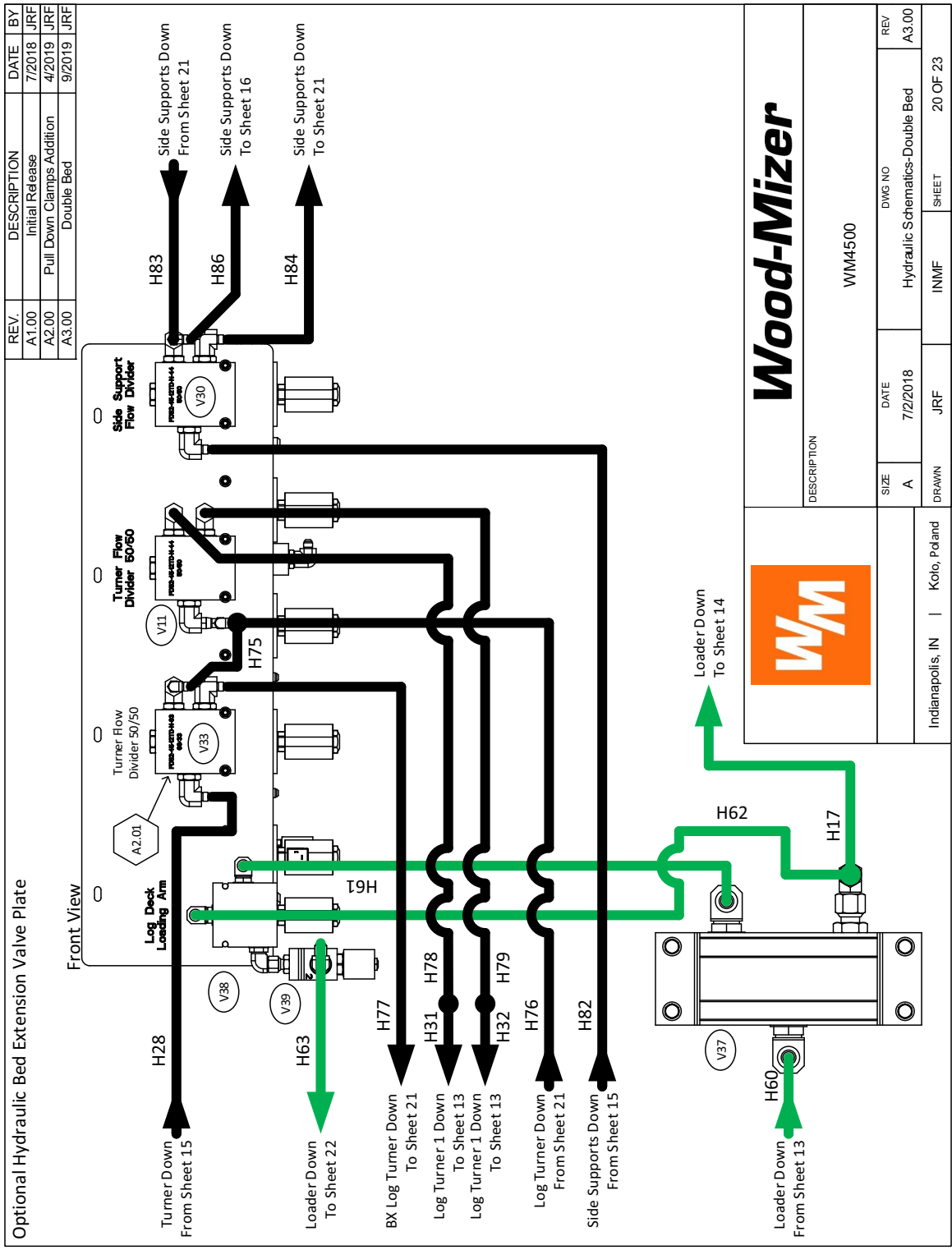

Wood-Mizer



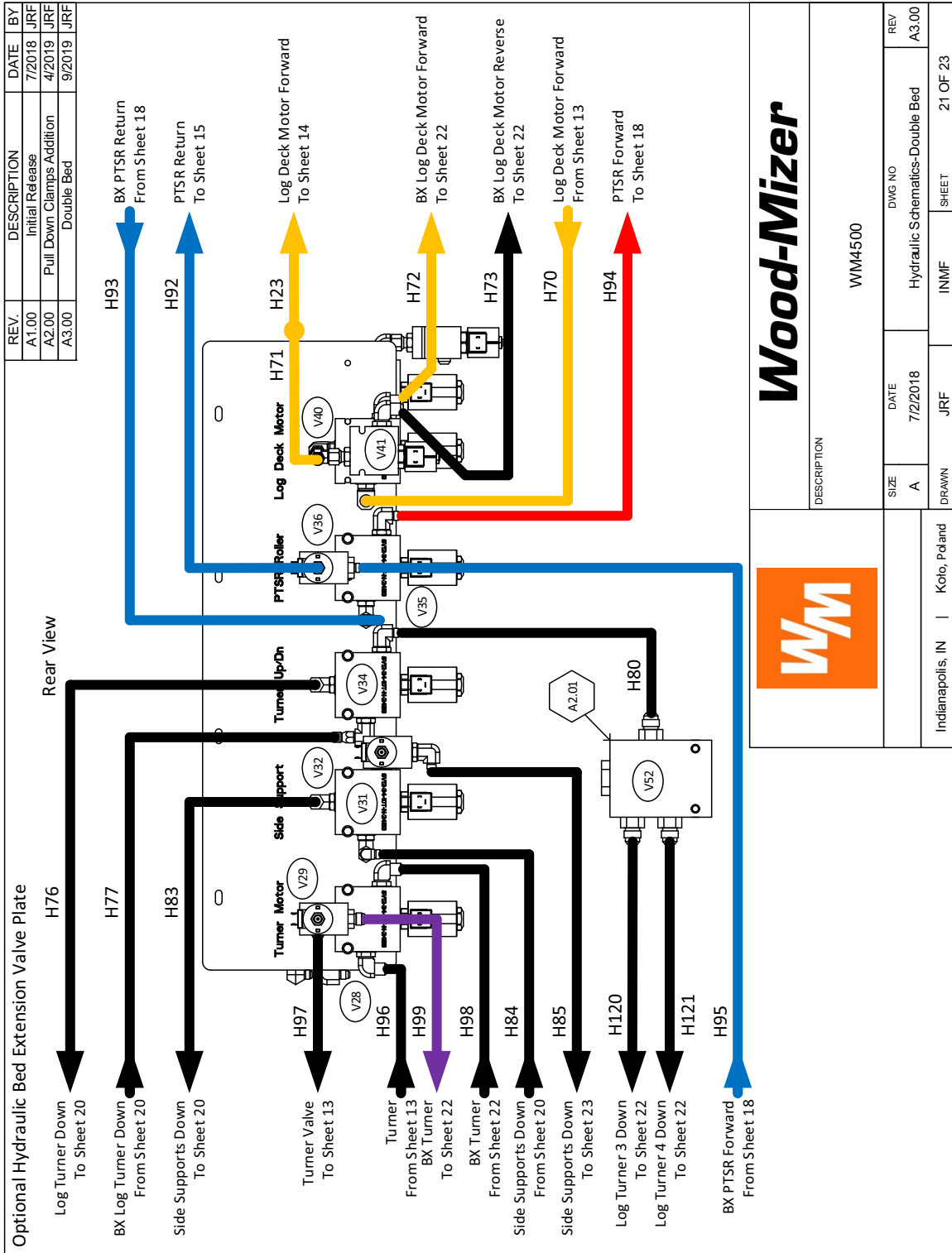

Wood-Mizer



DESCRIPTION		WM4500	
SIZE	DATE	DWG NO	REV
A	7/2/2018	Hydraulic Schematics-Double Bed	A3.00
DRAWN	JRF	IN/MF	SHEET
Indianapolis, IN	Kolo, Poland		21 OF 23

8 Hydraulic Information

Hydraulic Schematics Double Bed

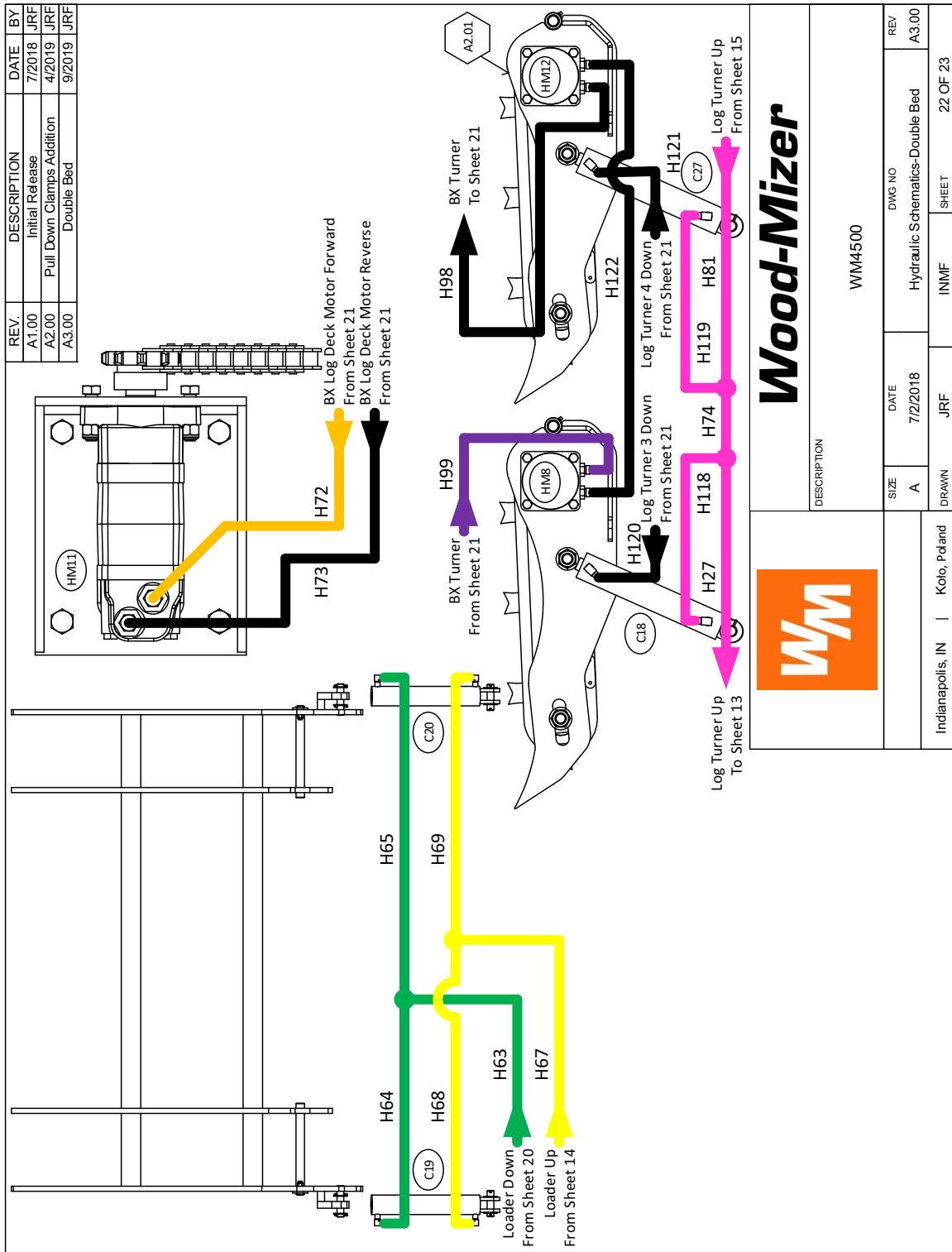

REV	DESCRIPTION	DATE	BY
A1.00	Initial Release	7/2018	JRF
A2.00	Pull Down Clamps Addition	4/2019	JRF
A3.00	Double Bed	9/2019	JRF

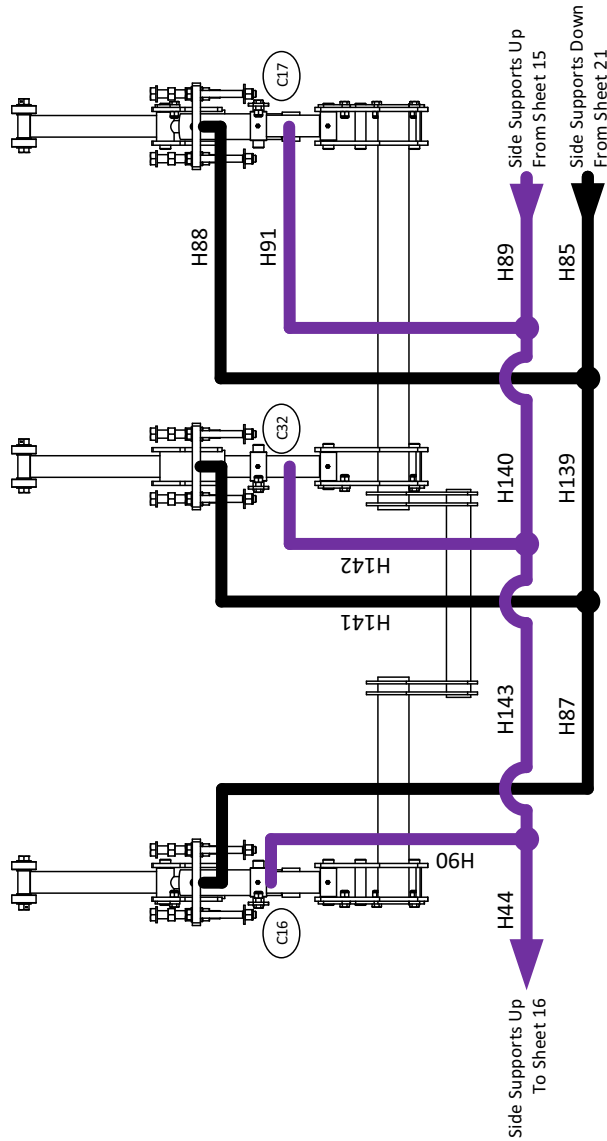

		DESCRIPTION	
		WM4500	
SIZE	DATE	DWG NO	REV
A	7/2/2018	Hydraulic Schematics-Double Bed	A3.00
DRAWN	JRF	IN/MF	SHEET
Indianapolis, IN	Koto, Poland		23 OF 23

8.4 Hydraulic Components

12/6/2019

WM4500 rev A3.00-
Hydraulic Component List

Wood-Mizer P/N WM4500
Rev. C

Component List					
ID		Description	XREF	Wood-Mizer Part #	
PU		Power Unit, Hyd, 40Gal, 15HP, 3000PSI		065938-1	
	1	Tank, Hydraulic Reservoir Custom	1	N/A	
	2	Coupling, Pump	1	068252	
		Coupling, Motor		068253	
		Coupling, Insert		068254	
	3	Adapter, C-Face Pump Mtr SAE B	1	078397	
	F1	Strainer, Suction w/Bypass	1	078690	
	F2	Filter, Hyd Cstr 35GPM 725psi w/Incl SAE16 (Includes Element)	1, 8	078395	
		Filter, Hyd. Element 10 Micron 25psi Byp		078341	
	G1	Gauge, Pressure VPG25N3KL	1, 9	068265	
	M2	Motor, 15HP 230/460 3PH 60Hz	1	078670	
	MFLD1		D05, 4-Station Manifold	2, 3, 9	061190
		V4	Y20 Valve, D05 2Pos A-B Tank (Includes Coils)	2, 9	078686
		V5	Y21-22 Valve, D05 3Pos A-B Tank (Includes Coils)	2, 9	078685
		V6	Y23-24 Valve, Loader Directional Up/Dn (Includes Coils)	2, 9	078756
			Plate, Cover D05 Valve		078399
		V7	Y25-26 Valve, Log Deck Directional Fwd/Rev (Includes Coils)	3, 9	078685
			Plate, Cover D05 Valve		078399
		V54	Valve, Press Comp Flow Ctl 12GPM Cmplt	2, 9	078737
			Valve Body, D05 Sandwich Flow Ctl Port B		078681
			Valve, Press Comp Flow Ctl 12GPM		078682
	MFLD2	Manifold Shell Only, WM4000 AD03P082S	3, 4, 5, 6, 11	061185	
	V8	Y4-5 Valve, D03 3Pos A-B Tank (Includes Coils)	3, 11	078683	
	V9	Valve, D03 PO Check	3, 11	078738	
	V10	Y6-7 Valve, D03 3Pos Blocked (Includes Coils)	4, 11	078684	
	V12	Y8-9 Valve, D03 3Pos A-B Tank (Includes Coils)	4, 11	078683	
	V13	Valve, D03 PO Check	4, 11	078738	
	V14	Y10-11 Valve, D03 3Pos A-B Tank (Includes Coils)	4, 11	078683	
	V15	Valve, D03 PO Check	4, 11	078738	
	V16	Y12-13 Valve, D03 3Pos A-B Tank (Includes Coils)	5, 11	078683	
	V17	Y14-15 Valve, D03 3Pos A-B Tank (Includes Coils)	5, 11	078683	
	V18	Valve, D03 PO Check	5, 11	078738	
	V19	Y16-17 Valve, D03 3Pos Blocked (Includes Coils)	5, 11	078684	
	V20	Y18-19 Valve, D03 3Pos A-B Tank (Includes Coils)	6, 11	078683	
	V21	Valve, D03 PO Check	6, 11	078738	
	P1	Pump, Hyd. 17GPM Piston Load Sense	1, 8	078671	
	V1	Valve, Snubber MFG250BF	1	068264	
	V2		Valve, Proportional PV72-30A	1, 8	068273
			Block, Valve Body HF 7022350		061290
		PV1	Valve, Proportional 15GPM PV72-30A		078185
		Y27	Valve, Proportional Coil PV72-30A		068258
		PV1/Y27	Valve, Proportional Cartridge PB72-30A (Includes Coil)		068257
	V3		Valve, Relief 250-3300psi RV10-20A Cmplt	1, 8	078735
			Valve, Body 10-Size 2-Way SAE12		078672
		RV1	Valve, Relief 250-3300psi RV10-20A Ctg		078673
	MFLD4		Manifold, D03 4 Station AI SAE	7, 13	078885
		V44	Y30-31 Valve, D03 3Pos A-B Tank (Includes Coils)	7, 13	078683
V45		Valve, D03 PO Check	7, 13	078738	
V46		Y32-33 Valve, D03 3Pos A-B Tank (Includes Coils)	7, 13	078683	
V47		Valve, D03 PO Check	7, 13	078738	
V48		Y34-35 Valve, D03 3Pos A-B Tank (Includes Coils)	7, 13	078683	
V49		Valve, D03 PO Check	7, 13	078738	
V50		Y36-37 Valve, D03 3Pos A-B Tank (Includes Coils)	7, 13	078683	
V51		Valve, D03 PO Check	7, 13	078738	
C1-2			Cylinder, 2-1/2 Bore x 12x22-1/4	2, 10	050105
		Seal Kit, 2 1/2x8 Hydraulic Cylinder	P12955		
C3		Cylinder, Hyd 3x6	3, 11	P12955	
C4-5		Cylinder, 2x10 Rod End Welded 16"	4, 9	034267	

12/6/2019

WM4500 rev A3.00-
Hydraulic Component List

Wood-Mizer P/N WM4500
Rev. C

Component List						
ID				Description	XREF	Wood-Mizer Part #
				Seal Kit, Hyd Cylinder 2x10 (034267)	4, 11	003814
C6				Cylinder, Hyd 2x14	4, 11	062701
C7				Cylinder, 1 1/2x6 Rod End In Line Ports	4, 11	014482
				Seal Kit, 1 1/2x6 Hyd Cyl		014547
C8				Cylinder, 1 1/2x6 Rod End In Line Ports	5, 11	014482
				Seal Kit, 1 1/2x6 Hyd Cyl		014547
C10-11				Cylinder, 2x6, 1/4 NPT Port	6, 12	035625
				Seal Kit, Hyd Cylinder , 2x6 (035625)		003812
C21-22				Cylinder, 2x6, 1/4 NPT Port	6, 12	035625
				Seal Kit, Hyd Cylinder , 2x6 (035625)		003812
C23				Cylinder, CJ7F-16-40/22 + UE2-40W Hydraulic	7, 13	088662
C24				Cylinder, SJ2F-40/22/145 Hydraulic	7, 13	088661
C25				Cylinder, CJ7F-16-40/22 + UE2-40W Hydraulic	7, 13	088662
C26				Cylinder, SJ2F-40/22/145 Hydraulic	7, 13	088661
C31				Cylinder, 2x6, 1/4 NPT Port	6, 12	035625
				Seal Kit, Hyd Cylinder , 2x6 (035625)		003812
HM1-2				Motor, Hydraulic TBO165FP100AAAA	2, 9	P20206
HM3-4				Motor, Hydraulic TGO475US080AAFU	2, 9	007331
HM5				Motor, Hyd Log Deck	3, 10	056062
HM6-7				Motor, Hydraulic, TB0130FP130AAAA	5, 11	074281
				Kit, Hydraulic Motor Seal		061136
V11				Flow Divider, Hydraulic	4, 11	025742
V42				Valve, 3-Way Selector	6, 12	074286
				Valve, Spool 3-Way Cartridge		078448
	Y29			Coil, Series 12 DIN 24VDC EG		078447
V43				Valve, 3-Way Selector	6, 12	074286
				Valve, Spool 3-Way Cartridge		078448
	Y30			Coil, Series 12 DIN 24VDC EG		078447
				Fluid, Univis HVI 26 Hydraulic 1 Gallon(Sytem Holds 20 Gal. of Oil)		074744
				Fluid, Univis HVI 26 Hydraulic 5 Gallon(Sytem Holds 20 Gal. of Oil)		061164

8.5 Hydraulic Components BX12

12/6/2019

WM4500 w/BX12 - rev A3.00
Hydraulic Component List

Wood-Mizer P/N WM4500
Rev. C

Component List					
ID	Description			XREF	Wood-Mizer Part #
PU			Power Unit, Hyd, 40Gal, 15HP, 3000PSI		065938-1
	1		Tank, Hydraulic Reservoir Custom	1	N/A
	2		Coupling, Pump		068252
			Coupling, Motor	1	068253
			Coupling, Insert		068254
	3		Adapter, C-Face Pump Mtr SAE B	1	078397
	F1		Strainer, Suction w/Bypass	1	078690
	F2		Filter, Hyd Cstr 35GPM 725psi wind SAE16 (Includes Element)	1, 12	078395
			Filter, Hyd. Element 10 Micron 25psi Byp		078341
	G1		Gauge, Pressure VPG25N3KL	1, 13	068265
	M2		Motor, 15HP 230/460 3PH 60Hz	1	078670
	MFLD1		D05, 4-Station Manifold	2, 3, 13	061190
	V4	Y20	Valve, D05 2Pos A-B Tank (Includes Coils)	2, 13	078686
	V5	Y21-22	Valve, D05 3Pos A-B Tank (Includes Coils)	2, 13	078685
	V6	Y23-24	Valve, D05 3Pos Blocked (Includes Coils)		078756
			Plate, Cover D05 Valve	2, 13	078399
	V7	Y25-26	Valve, D05 3Pos A-B Tank (Includes Coils)		078685
			Plate, Cover D05 Valve	3, 13	078399
	V54		Valve, Press Comp Flow Ctl 12GPM Cmplt		078737
			Valve Body, D05 Sandwich Flow Ctl Port B	2, 13	078681
			Valve, Press Comp Flow Ctl 12GPM		078682
	MFLD2		Manifold Shell Only, WM4000 AD03P082S	3, 4, 5, 6, 15	061185
	V8	Y4-5	Valve, D03 3Pos A-B Tank (Includes Coils)	3, 15	078683
	V9		Valve, D03 PO Check	3, 15	078738
	V10	Y6-7	Valve, D03 3Pos Blocked (Includes Coils)	4, 15	078684
	V12	Y8-9	Valve, D03 3Pos A-B Tank (Includes Coils)	4, 15	078683
	V13		Valve, D03 PO Check	4, 15	078738
	V14	Y10-11	Valve, D03 3Pos A-B Tank (Includes Coils)	4, 15	078683
	V15		Valve, D03 PO Check	4, 15	078738
	V16	Y12-13	Valve, D03 3Pos A-B Tank (Includes Coils)	5, 15	078683
	V17	Y14-15	Valve, D03 3Pos A-B Tank (Includes Coils)	5, 15	078683
	V18		Valve, D03 PO Check	5, 15	078738
	V19	Y16-17	Valve, D03 3Pos Blocked (Includes Coils)	5, 15	078684
	V20	Y18-19	Valve, D03 3Pos A-B Tank (Includes Coils)	6, 15	078683
	V21		Valve, D03 PO Check	6, 15	078738
	MFLD3		Manifold, AD03P032S 3-Section	8, 18	074293
	V22	Y150-151	Valve, D03 3Pos A-B Tank (Includes Coils)	8, 18	078683
	V23		Valve, D03 PO Check	8, 18	078738
	V24	Y152-153	Valve, D03 3Pos A-B Tank (Includes Coils)	8, 18	078683
	V25		Valve, D03 PO Check	8, 18	078738
	V26	Y154-155	Valve, D03 3Pos A-B Tank (Includes Coils)	8, 18	078683
	V27		Valve, D03 PO Check	8, 18	078738
	P1		Pump, Hyd. 17GPM Piston Load Sense	1, 12	078671
	V1		Valve, Snubber MFG250BF	1	068264
	V2		Valve, Proportional PV72-30A		068273
			Block, Valve Body HF 7022350		061290
	PV1		Valve, Proportional 15GPM PV72-30A	1, 12	078185
	Y27		Valve, Proportional Coil PV72-30A		068258
	PV1/Y27		Valve, Proportional Cartridge PB72-30A (Includes Coil)		068257
	V3		Valve, Relief 250-3300psi RV10-20A Cmplt		078735
			Valve, Body 10-Size 2-Way SAE12	1, 12	078672
	RV1		Valve, Relief 250-3300psi RV10-20A Ctg		078673

12/6/2019

WM4500 w/BX12 - rev A3.00
Hydraulic Component List

Wood-Mizer P/N WM4500
Rev. C

Component List				
ID	Description	XREF	Wood-Mizer Part #	
MFLD4		Manifold, D03 4 Station Al SAE	7, 17 078885	
	V44	Y30-31	Valve, D03 3Pos A-B Tank (Includes Coils)	7, 17 078683
	V45		Valve, D03 PO Check	7, 17 078738
	V46	Y32-33	Valve, D03 3Pos A-B Tank (Includes Coils)	7, 17 078683
	V47		Valve, D03 PO Check	7, 17 078738
	V48	Y34-35	Valve, D03 3Pos A-B Tank (Includes Coils)	7, 17 078683
	V49		Valve, D03 PO Check	7, 17 078738
	V50	Y36-37	Valve, D03 3Pos A-B Tank (Includes Coils)	7, 17 078683
	V51		Valve, D03 PO Check	7, 17 078738
C1-2		Cylinder, 2-1/2 Bore x 12x22-1/4	2, 14 050105	
		Seal Kit, 2 1/2x8 Hydraulic Cylinder	P12955	
C3		Cylinder, Hyd 3x6	3, 15 P12955	
C4-5		Cylinder, 2x10 Rod End Welded 16"	4, 13 034267	
		Seal Kit, Hyd Cylinder 2x10 (034267)	003814	
C6		Cylinder, Hyd 2x14	4, 15 062701	
C7		Cylinder, 1 1/2x6 Rod End In Line Ports	4, 15 014482	
		Seal Kit, 1 1/2x6 Hyd Cyl	014547	
C8		Cylinder, 1 1/2x6 Rod End In Line Ports	5, 15 014482	
		Seal Kit, 1 1/2x6 Hyd Cyl	014547	
C10-11		Cylinder, 2x6, 1/4 NPT Port	6, 16 035625	
		Seal Kit, Hyd Cylinder , 2x6 (035625)	003812	
C12-13		Cylinder, 1 1/2x6 Rod End In Line Ports	8, 18 014482	
		Seal Kit, 1 1/2x6 Hyd Cyl	014547	
C14		Cylinder, Hyd 2x14	8, 18 062701	
C15		Cylinder, Hyd 3x6	8, 18 P12955	
C16-17		Cylinder, 2x6, 1/4 NPT Port	9, 22 035625	
		Seal Kit, Hyd Cylinder , 2x6 (035625)	003812	
C18		Cylinder, 2x10 Rod End Welded 16"	10, 21 034267	
		Seal Kit, Hyd Cylinder 2x10 (034267)	003814	
C19-20		Cylinder, 2-1/2 Bore x 12x22-1/4	11, 21 050105	
		Seal Kit, 2 1/2x8 Hydraulic Cylinder	P12955	
C23		Cylinder, CJ7F-16-40/22 + UE2-40W Hydraulic	7, 17 088662	
C24		Cylinder, SJ2F-40/22/145 Hydraulic	7, 17 088661	
C25		Cylinder, CJ7F-16-40/22 + UE2-40W Hydraulic	7, 17 088662	
C26		Cylinder, SJ2F-40/22/145 Hydraulic	7, 17 088661	
C31		Cylinder, 2x6, 1/4 NPT Port	6, 16 035625	
		Seal Kit, Hyd Cylinder , 2x6 (035625)	003812	
HM1-2		Motor, Hydraulic TBO165FP100AAAA	2, 13 P20206	
HM3-4		Motor, Hydraulic TG0475US080AAFU	2, 13 007331	
HM5		Motor, Hyd Log Deck	3, 14 056062	
HM6-7		Motor, Hydraulic, TB0130FP130AAAA	5, 15 074281	
		Kit, Hydraulic Motor Seal	061136	
HM8		Motor, Hydraulic TG0475US080AAFU	9, 21 007331	
HM9-10		Motor, Hydraulic, TB0130FP130AAAA	10, 18 074281	
		Kit, Hydraulic Motor Seal	061136	
HM11		Motor, Hyd Log Deck	11, 21 056062	
V11		Valve, 50/50 Flow Divider/Combiner	4, 19 074289	
V28		Valve, 3-Way Selector	9, 20 074286	
		Valve, Spool 3-Way Cartridge	078448	
	Y101	Coil, Series 12 DIN 24VDC EG	078447	
V29		Valve, 2-Way Normally Closed Blocking	9, 20 074287	
	Y102	Coil, Hyd Valve 24VDC	025835	
V30		Valve, 50/50 Flow Divider/Combiner	9, 19 074289	
V31		Valve, 3-Way Selector	9, 20 074286	
		Valve, Spool 3-Way Cartridge	078448	
	Y103	Coil, Series 12 DIN 24VDC EG	078447	
V32		Valve, 2-Way Normally Closed Blocking	9, 20 074287	
	Y104	Coil, Hyd Valve 24VDC	025835	



Hydraulic Information

Hydraulic Components BX12

12/6/2019

WM4500 w/BX12 - rev A3.00
Hydraulic Component List

Wood-Mizer P/N WM4500
Rev. C

Component List			
ID	Description	XREF	Wood-Mizer Part #
V33	Valve, 66/33 Flow Divider/Combiner	10, 19	074290
V34	Valve, 3-Way Selector	10, 20	074286
	Valve, Spool 3-Way Cartridge		078448
	Coil, Series 12 DIN 24VDC EG		078447
V35	Valve, 3-Way Selector	10, 20	074286
	Valve, Spool 3-Way Cartridge		078448
	Coil, Series 12 DIN 24VDC EG		078447
V36	Valve, 2-Way Normally Closed Blockin	10, 20	074287
	Coil, Hyd Valve 24VDC		025835
V37	Flow Divider, 2 Section Bailey 50/50	11, 19	074325
V38	Valve, 3-Way Selector	11, 19	074286
	Valve, Spool 3-Way Cartridge		078448
	Coil, Series 12 DIN 24VDC EG		078447
V39	Valve, 2-Way Normally Closed Blockin	11, 19	074287
	Coil, Hyd Valve 24VDC		025835
V40	Valve, 3-Way Selector	11, 20	074286
	Valve, Spool 3-Way Cartridge		078448
	Coil, Series 12 DIN 24VDC EG		078447
V41	Valve, 2-Way Normally Closed Blockin	11, 20	074287
	Coil, Hyd Valve 24VDC		025835
	Fluid, Univis HVI 26 Hydraulic 1 Gallon(Sytem Holds 20 Gal. of Oil)		074744
	Fluid, Univis HVI 26 Hydraulic 5 Gallon(Sytem Holds 20 Gal. of Oil)		061164

8.6 Hydraulic Components Double Bed

Component List							
ID	Description	XREF	Wood-Mizer Part #				
PU		Power Unit, Hyd, 40Gal, 15HP, 3000PSI	1	065938-1			
	1	Tank, Hydraulic Reservoir Custom	1	N/A			
	2	Coupling, Pump	1	068252			
		Coupling, Motor		068253			
		Coupling, Insert		068254			
	3	Adapter, C-Face Pump Mtr SAE B	1	078397			
	F1	Strainer, Suction w/Bypass	1	078690			
	F2	Filter, Hyd Cstr 35GPM 725psi w/nd SAE16 (Includes Element)	1, 12	078395			
		Filter, Hyd. Element 10 Micron 25psi Byp		078341			
	G1	Gauge, Pressure VPG25N3KL	1, 13	068265			
	M2	Motor, 15HP 230/460 3PH 60Hz	1	078670			
	MFLD1		D05, 4-Station Manifold	2, 3, 13	061190		
		V4	Y20 Valve, D05 2Pos A-B Tank (Includes Coils)	2, 13	078686		
		V5	Y21-22 Valve, D05 3Pos A-B Tank (Includes Coils)	2, 13	078685		
		V6	Y23-24 Valve, D05 3Pos Blocked (Includes Coils)	2, 13	078756		
			Plate, Cover D05 Valve		078399		
		V7	Y25-26 Valve, D05 3Pos A-B Tank (Includes Coils)	3, 13	078685		
			Plate, Cover D05 Valve		078399		
		V54	Valve, Press Comp Flow Ctl 12GPM Cmpmt	2, 13	078737		
			Valve Body, D05 Sandwich Flow Ctl Port B		078681		
			Valve, Press Comp Flow Ctl 12GPM		078682		
	MFLD2		Manifold Shell Only, WM4000 AD03P082S	3, 4, 5, 6, 15	061185		
		V8	Y4-5 Valve, D03 3Pos A-B Tank (Includes Coils)	3, 15	078683		
		V9	Valve, D03 PO Check	3, 15	078738		
		V10	Y6-7 Valve, D03 3Pos Blocked (Includes Coils)	4, 15	078684		
		V12	Y8-9 Valve, D03 3Pos A-B Tank (Includes Coils)	4, 15	078683		
		V13	Valve, D03 PO Check	4, 15	078738		
		V14	Y10-11 Valve, D03 3Pos A-B Tank (Includes Coils)	4, 15	078683		
		V15	Valve, D03 PO Check	4, 15	078738		
		V16	Y12-13 Valve, D03 3Pos A-B Tank (Includes Coils)	5, 15	078683		
		V17	Y14-15 Valve, D03 3Pos A-B Tank (Includes Coils)	5, 15	078683		
		V18	Valve, D03 PO Check	5, 15	078738		
		V19	Y16-17 Valve, D03 3Pos Blocked (Includes Coils)	5, 15	078684		
		V20	Y18-19 Valve, D03 3Pos A-B Tank (Includes Coils)	6, 15	078683		
		V21	Valve, D03 PO Check	6, 15	078738		
		MFLD3		Manifold, AD03P032S 3-Section	8, 18	074293	
			V22	Y150-151 Valve, D03 3Pos A-B Tank (Includes Coils)	8, 18	078683	
	V23		Valve, D03 PO Check	8, 18	078738		
	V24		Y152-153 Valve, D03 3Pos A-B Tank (Includes Coils)	8, 18	078683		
	V25		Valve, D03 PO Check	8, 18	078738		
	V26		Y154-155 Valve, D03 3Pos A-B Tank (Includes Coils)	8, 18	078683		
	V27		Valve, D03 PO Check	8, 18	078738		
	P1	Pump, Hyd. 17GPM Piston Load Sense	1, 12	078671			
	V1	Valve, Snubber MFG250BF	1	068264			
	V2		Valve, Proportional PV72-30A	1, 12	068273		
			Block, Valve Body HF 7022350		061290		
		PV1	Valve, Proportional 15GPM PV72-30A		078185		
		Y27	Valve, Proportional Coil PV72-30A		068258		
		PV1/Y27	Valve, Proportional Cartridge PB72-30A (Includes Coil)		068257		
V3		Valve, Relief 250-3300psi RV10-20A Cmpmt	1, 12	078735			
		Valve, Body 10-Size 2-Way SAE12		078672			
	RV1	Valve, Relief 250-3300psi RV10-20A Ctg		078673			
MFLD4		Manifold, D03 4 Station AI SAE	7, 17	078885			
	V44	Y30-31 Valve, D03 3Pos A-B Tank (Includes Coils)	7, 17	078683			
	V45	Valve, D03 PO Check	7, 17	078738			
	V46	Y32-33 Valve, D03 3Pos A-B Tank (Includes Coils)	7, 17	078683			
	V47	Valve, D03 PO Check	7, 17	078738			
	V48	Y34-35 Valve, D03 3Pos A-B Tank (Includes Coils)	7, 17	078683			
	V49	Valve, D03 PO Check	7, 17	078738			



Hydraulic Information

Hydraulic Components Double Bed

12/6/2019

WM4500 w/Double Bed -
Hydraulic Component List

Wood-Mizer P/N WM4500
Rev. C

Component List						
ID			Description	XREF	Wood-Mizer Part #	
	V50	Y36-37	Valve, D03 3Pos A-B Tank (Includes Coils)	7, 17	078683	
	V51		Valve, D03 PO Check	7, 17	078738	

Component List				
ID	Description	XREF	Wood-Mizer Part #	
C1-2	Cylinder, 2-1/2 Bore x 12x22-1/4	2, 14	050105	
	Seal Kit, 2 1/2x8 Hydraulic Cylinder		P12955	
C3	Cylinder, Hyd 3x6	3, 16	P12955	
C4-5	Cylinder, 2x10 Rod End Welded 16"	4, 13	034267	
	Seal Kit, Hyd Cylinder 2x10 (034267)		003814	
C6	Cylinder, Hyd 2x14	4, 16	062701	
C7	Cylinder, 1 1/2x6 Rod End In Line Ports	4, 15	014482	
	Seal Kit, 1 1/2x6 Hyd Cyl		014547	
C8	Cylinder, 1 1/2x6 Rod End In Line Ports	5, 15	014482	
	Seal Kit, 1 1/2x6 Hyd Cyl		014547	
C10-11	Cylinder, 2x6, 1/4 NPT Port	6, 16	035625	
	Seal Kit, Hyd Cylinder , 2x6 (035625)		003812	
C12-13	Cylinder, 1 1/2x6 Rod End In Line Ports	8, 18	014482	
	Seal Kit, 1 1/2x6 Hyd Cyl		014547	
C14	Cylinder, Hyd 2x14	8, 19	062701	
C15	Cylinder, Hyd 3x6	8, 19	P12955	
C16-17	Cylinder, 2x6, 1/4 NPT Port	9, 23	035625	
	Seal Kit, Hyd Cylinder , 2x6 (035625)		003812	
C18	Cylinder, 2x10 Rod End Welded 16"	10, 22	034267	
	Seal Kit, Hyd Cylinder 2x10 (034267)		003814	
C19-20	Cylinder, 2-1/2 Bore x 12x22-1/4	11, 22	050105	
	Seal Kit, 2 1/2x8 Hydraulic Cylinder		P12955	
C23	Cylinder, CJ7F-16-40/22 + UE2-40W Hydraulic	7, 17	088662	
C24	Cylinder, SJ2F-40/22/145 Hydraulic	7, 17	088661	
C25	Cylinder, CJ7F-16-40/22 + UE2-40W Hydraulic	7, 17	088662	
C26	Cylinder, SJ2F-40/22/145 Hydraulic	7, 17	088661	
C27	Cylinder, 2x10 Rod End Welded 16"	10, 22	034267	
	Seal Kit, Hyd Cylinder 2x10 (034267)		003814	
C28	Cylinder, 1 1/2x6 Rod End In Line Ports	5, 18	014482	
	Seal Kit, 1 1/2x6 Hyd Cyl		014547	
C29	Cylinder, Hyd 3x6	8, 19	P12955	
C30	Cylinder, Hyd 2x14	8, 19	062701	
C31	Cylinder, 2x6, 1/4 NPT Port	6, 16	035625	
	Seal Kit, Hyd Cylinder , 2x6 (035625)		003812	
C32	Cylinder, 2x6, 1/4 NPT Port	9, 23	035625	
	Seal Kit, Hyd Cylinder , 2x6 (035625)		003812	
HM1-2	Motor, Hydraulic TBO165FP100AAAA	2, 13	P20206	
HM3-4	Motor, Hydraulic TG0475US080AAFU	2, 13	007331	
HM5	Motor, Hyd Log Deck	3, 14	056062	
HM6-7	Motor, Hydraulic, TB0130FP130AAAA	5, 15	074281	
	Kit, Hydraulic Motor Seal		061136	
HM8	Motor, Hydraulic TG0475US080AAFU	9, 22	007331	
HM9-10	Motor, Hydraulic, TB0130FP130AAAA	10, 18	074281	
	Kit, Hydraulic Motor Seal		061136	
HM11	Motor, Hyd Log Deck	11, 22	056062	
HM12	Motor, Hydraulic TG0475US080AAFU	9, 22	007331	
HM13	Motor, Hydraulic, TB0130FP130AAAA	10, 18	074281	
	Kit, Hydraulic Motor Seal		061136	
V11	Valve, 50/50 Flow Divider/Combiner	4, 20	074289	
V28	Valve, 3-Way Selector	9, 21	074286	
	Valve, Spool 3-Way Cartridge		078448	
	Coil, Series 12 DIN 24VDC EG		078447	
V29	Valve, 2-Way Normally Closed Blocking	9, 21	074287	
	Coil, Hyd Valve 24VDC		025835	
V30	Valve, 50/50 Flow Divider/Combiner	9, 20	074289	
V31	Valve, 3-Way Selector	9, 21	074286	
	Valve, Spool 3-Way Cartridge		078448	
	Coil, Series 12 DIN 24VDC EG		078447	



Hydraulic Information

Hydraulic Components Double Bed

Component List				
ID	Description		XREF	Wood-Mizer Part #
V32		Valve, 2-Way Normally Closed Blockin	9, 21	074287
	Y104	Coil, Hyd Valve 24VDC		025835
V33		Valve, 50/50 Flow Divider/Combiner	10, 20	074289
V34		Valve, 3-Way Selector	10, 21	074286
		Valve, Spool 3-Way Cartridge		078448
	Y105	Coil, Series 12 DIN 24VDC EG		078447
V35		Valve, 3-Way Selector	10, 21	074286
		Valve, Spool 3-Way Cartridge		078448
	Y106	Coil, Series 12 DIN 24VDC EG		078447
V36		Valve, 2-Way Normally Closed Blockin	10, 21	074287
	Y107	Coil, Hyd Valve 24VDC		025835
V37		Flow Divider, 2 Section Bailey 50/50	11, 20	074325
V38		Valve, 3-Way Selector	11, 20	074286
		Valve, Spool 3-Way Cartridge		078448
	Y108	Coil, Series 12 DIN 24VDC EG		078447
V39		Valve, 2-Way Normally Closed Blockin	11, 20	074287
	Y109	Coil, Hyd Valve 24VDC		025835
V40		Valve, 3-Way Selector	11, 21	074286
		Valve, Spool 3-Way Cartridge		078448
	Y110	Coil, Series 12 DIN 24VDC EG		078447
V41		Valve, 2-Way Normally Closed Blockin	11, 21	074287
	Y111	Coil, Hyd Valve 24VDC		025835
V42		Valve, 3-Way Selector	N/A	074286
		Valve, Spool 3-Way Cartridge		078448
	Y29	Coil, Series 12 DIN 24VDC EG		078447
V43		Valve, 3-Way Selector	N/A	074286
		Valve, Spool 3-Way Cartridge		078448
	Y30	Coil, Series 12 DIN 24VDC EG		078447
V52		Flow Divider, Hydraulic	10, 21	025742
V55		Valve, 3-Way Selector	8, 19	074286
		Valve, Spool 3-Way Cartridge		078448
	Y112	Coil, Series 12 DIN 24VDC EG		078447
V56		Valve, 3-Way Selector	8, 19	074286
		Valve, Spool 3-Way Cartridge		078448
	Y113	Coil, Series 12 DIN 24VDC EG		078447
V57		Valve, 3-Way Selector	8, 19	074286
		Valve, Spool 3-Way Cartridge		078448
	Y114	Coil, Series 12 DIN 24VDC EG		078447
V58		Valve, 3-Way Selector	8, 19	074286
		Valve, Spool 3-Way Cartridge		078448
	Y115	Coil, Series 12 DIN 24VDC EG		078447
		Fluid, Univis HVI 26 Hydraulic 1 Gallon(Sytem Holds 20 Gal. of Oil)		074744
		Fluid, Univis HVI 26 Hydraulic 5 Gallon(Sytem Holds 20 Gal. of Oil)		061164

8.7 Hydraulic Hoses

12/6/2019

WM4500 rev A3.00-
Hose List

Wood-Mizer P/N WM4500
Rev. C

Hose List					
ID	Color	Length	Description	XREF	Wood-Mizer PN
H1	Steel Line/Hose		Tube, 1-1/4" Suction to Pump	8	078736
H2	Steel Line/Hose		Tube, 1/4" Hyd. Load Sense	8	078761
H3	Steel Line/Hose		Tube, 3/4" Hyd. Prop to Relief	8	078760
H4	N/A	N/A	Hose, 1/2" Case Drain	8	078767
H5	Steel Line		Tube, 1-1/4" Filter to Tank	8	078764
H6	Steel Line/Hose		Tube, 3/4" Hyd. Prop to Mfld1	8, 9	078762
H7	Steel Line/Hose		Tube, 1" Hyd. Mfld1 to Filter	8, 9	078765
H8	Steel Line/Hose		Tube, 3/4" Hyd. Mfld1 to Mfld2 Pressure	9, 11	078763
H9	Steel Line/Hose		Tube, 1" Hyd. Mfld2 to Filter	8, 11	078766
H10	Blue	471"	1/2" Conveyor Motor Return	9	079004-471
H11	Red	471"	1/2" Conveyor Motor Drive	9	079004-471
H12	Red	156"	1/2" Bed Conveyor Motor to Incline Conveyor Motor	9	079004-156
H13	Blue	156"	1/2" Incline Conveyor Motor Return	9	079004-156
H14	Black	334"	1/2" Turner (near) Motor	9	079004-334
H15	Plain	132"	1/2" Turner Motor (near) to Turner Motor (far)	9	079004-132
H16	Purple	350"	1/2" Turner (far) Motor	9	079004-350
H17	Green	310"	1/2" Loader T Top	9, 10	079004-310
H18	Yellow	310"	1/2" Loader T Base	9, 10	079004-310
H19	Green	72"	3/8" Loader T Top to Cylinder Top	10	079001-72
H20	Green	72"	3/8" Loader T Top to Cylinder Top	10	079001-72
H21	Yellow	72"	3/8" Loader T Base to Cylinder Base	10	079001-72
H22	Yellow	72"	3/8" Loader T Base to Cylinder Base	10	079001-72
H23	Orange	310"	1/2" Log Deck Motor B	9, 10	079004-310
H24	White	310"	1/2" Log Deck Motor A	9, 10	079004-310
H25	Orange	364"	3/8" Clamp In/Out Base	11	079001-364
H26	White	364"	3/8" Clamp In/Out Top	11	079001-364
H27	Pink	275"	3/8" Turner T Base	9, 11	079001-275
H28	Plain	85"	3/8" Turner Flow Divider	11	079001-85
H29	Pink	19"	3/8" Turner T Base to Cylinder 1 Base	9	079001-19
H30	Pink	39"	3/8" Turner T Base to Cylinder 2 Base	9	079001-39
H31	Plain	200"	3/8" Turner Flow Divider to Cylinder 1 Top	9, 11	079001-200
H32	Plain	216"	3/8" Turner Flow Divider to Cylinder 2 Top	9, 11	079001-216
H33	Yellow	364"	3/8" Clamp Up/Down Base	11	079001-364
H34	Green	364"	3/8" Clamp Up/Down Top	11	079001-364
H35	Grey	267"	1/4" Toe Board 1 Base	11	079000-267
H36	Yellow	270"	1/4" Toe Board 1 Top	11	079000-270
H37	Red	276"	3/8" Turner 1 Motor A	11	079001-276
H38	Blue	348"	3/8" Turner 2 Motor B	11	079001-348
H39	Plain	154"	3/8" Turner 1 Motor B to Turner 2 Motor A	11	079001-154
H40	Black	333"	1/4" Toe Board 2 Base	11	079000-333
H41	Purple	335"	1/4" Toe Board 2 Top	11	079000-335
H44	Purple	190"	3/8" Side Support T Base	12	079001-190
H45	Black	190"	3/8" Side Support T Top	12	079001-190

8

Hydraulic Information*Hydraulic Hoses*

12/6/2019

WM4500-rev A3.00

Wood-Mizer P/N WM4500

Hose List

Rev. C

Hose List					
ID	Color	Length	Description	XREF	Wood-Mizer PN
H49	Black	51"	3/8" Side Support T to Cylinder 2 Top	12	079001-51
H100	Black	48"	3/8" Pop Up Stop SV A Port 2	11, 12	079001-48
H101	Purple	48"	3/8" Pop Up Stop SV B Port 2	11, 12	079001-48
H102	Black	224"	3/8" Pop Up Stop SV A Port 3 to T	12	079001-224
H103	Purple	224"	3/8" Pop Up Stop SV B Port 3 to T	12	079001-224
H104	Black	48"	3/8" Pop Up Stop T to Cylinder 1 Top	12	079001-48
H105	Black	48"	3/8" Pop Up Stop T to Cylinder 2 Top	12	079001-48
H106	Purple	48"	3/8" Pop Up Stop T to Cylinder 1 Bottom	12	079001-48
H107	Purple	48"	3/8" Pop Up Stop T to Cylinder 2 Bottom	12	079001-48
H108	Black	44"	1/2" Pull Down D03 Manifold P to Main D03 P	11, 13	079004-44
H109	Black	36"	1/2" Pull Down D03 Manifold T to Main D03 T	11, 13	079004-36
H110	Black	456"	1/4" Pull Down Clamp 1 Up/Dn Base to Valve 1 A	13	079000-456
H111	Black	456"	1/4" Pull Down Clamp 1 Up/Dn Top to Valve 1 B	13	079000-456
H112	Black	456"	1/4" Pull Down Clamp 1 In/Out Base to Valve 2 B	13	079000-456
H113	Black	456"	1/4" Pull Down Clamp 1 In/Out Top to Valve 2 A	13	079000-456
H114	Black	336"	1/4" Pull Down Clamp 2 Up/Dn Base to Valve 3 A	13	079000-336
H115	Black	336"	1/4" Pull Down Clamp 2 Up/Dn Top to Valve 3 B	13	079000-336
H116	Black	336"	1/4" Pull Down Clamp 2 In/Out Base to Valve 4 B	13	079000-336
H117	Black	336"	1/4" Pull Down Clamp 2 In/Out Top to Valve 4 A	13	079000-336
H133	Purple	41"	3/8" SD Support 1 Top T to SD Support 2 Top T	12	079001-41
H134	Black	41"	3/8" SD Support 1 Base T to SD Support 2 Base T	12	079001-41
H135	Purple	55"	3/8" SD Support 1 Top T to SD Support 2 Top	12	079001-55
H136	Black	59"	3/8" SD Support 1 Base T to SD Support 2 Base	12	079001-59

8.8 Hydraulic Hoses BX12

12/6/2019

WM4500 w/BX12 - rev A3.00
Hose List

Wood-Mizer P/N WM4500
Rev. C

Hose List							
ID	Color	Length		Description	XREF	Wood-Mizer Part#	
		Std. Bed	12' Bed Ext.			Standard Bed	12ft. Bed Extensions
H1	Steel Line/Hose			Tube, 1-1/4" Suction to Pump	12		078736
H2	Steel Line/Hose			Tube, 1/4" Hyd. Load Sense	12		078761
H3	Steel Line/Hose			Tube, 3/4" Hyd. Prop to Relief	12		078760
H4	N/A	N/A	N/A	Hose, 1/2" Case Drain	12		078767
H5	Steel Line/Hose			Tube, 1-1/4" Filter to Tank	12		078764
H6	Steel Line/Hose			Tube, 3/4" Hyd. Prop to Mfld1	12, 13		078762
H7	Steel Line/Hose			Tube, 1" Hyd. Mfld1 to Filter	12, 13		078765
H8	Steel Line/Hose			Tube, 3/4" Hyd. Mfld1 to Mfld2 Pressure	13, 15		078763
H9	Steel Line/Hose			Tube, 1" Hyd. Mfld2 to Filter	12, 15		078766
H10	Blue	471"	144"	1/2" Conveyor Motor Return	13	079004-471	079004-144
H11	Red	471"	144"	1/2" Conveyor Motor Drive	13	079004-471	079004-144
H12	Red	156"		1/2" Bed Conveyor Motor to Incline Conveyor Motor	13	079004-156	
H13	Blue	156"		1/2" Incline Conveyor Motor Return	13	079004-156	
H14	Black	334"		1/2" Turner (near) Motor		079004-334	
H15	Plain	132"		1/2" Turner Motor (near) to Turner Motor (far)	13	079004-132	
H16	Purple	350"	144"	1/2" Turner (far) Motor	13	079004-350	079004-144
H17	Green	310"		1/2" Loader T Top	14, 19	079004-310	
H18	Yellow	310"		1/2" Loader T Base	14	079004-310	
H19	Green	72"		3/8" Loader T Top to Cylinder Top	14	079001-72	
H20	Green	72"		3/8" Loader T Top to Cylinder Top	14	079001-72	
H21	Yellow	72"		3/8" Loader T Base to Cylinder Base	14	079001-72	
H22	Yellow	72"		3/8" Loader T Base to Cylinder Base	14	079001-72	
H23	Orange	310"		1/2" Log Deck Motor B	14, 20	079004-310	
H24	White	310"	144"	1/2" Log Deck Motor A	13, 14	079004-310	079004-144
H25	Orange	364"	144"	3/8" Clamp In/Out Base	15	079001-364	079001-144
H26	White	364"	144"	3/8" Clamp In/Out Top	15	079001-364	079001-144
H27	Pink	275"	144"	3/8" Turner T Base	13, 15	079001-275	079001-144
H28	Plain	85"		3/8" Turner Flow Divider	15, 19	079001-85	
H29	Pink	19"		3/8" Turner T Base to Cylinder 1 Base	13	079001-19	
H30	Pink	39"		3/8" Turner T Base to Cylinder 2 Base	13	079001-39	
H31	Plain	200"		3/8" Turner Flow Divider to Cylinder 1 Top	13, 19	079001-200	
H32	Plain	216"		3/8" Turner Flow Divider to Cylinder 2 Top	13, 19	079001-216	
H33	Yellow	364"	144"	3/8" Clamp Up/Down Base	15	079001-364	079001-144
H34	Green	364"	144"	3/8" Clamp Up/Down Top	15	079001-364	079001-144
H35	Grey	267"	144"	1/4" Toe Board 1 Base	15	079000-267	079000-144
H36	Yellow	270"	144"	1/4" Toe Board 1 Top	15	079000-270	079000-144
H37	Red	276"	144"	3/8" PTSR 1 Motor A	15	079001-276	079001-144
H38	Blue	348"		3/8" PTSR 2 Motor B	15, 18	079001-348	
H39	Plain	154"		3/8" PTSR 1 Motor B to PTSR 2 Motor A	15	079001-154	
H40	Black	333"	144"	1/4" Toe Board 2 Base	15	079000-333	079000-144
H41	Purple	335"	144"	1/4" Toe Board 2 Top	15	079000-335	079000-144
H44	Purple	190"		3/8" Side Support T 1 Bottom	16, 22	079001-190	
H45	Black	190"		3/8" Side Support T 1 Top	16	079001-190	
H46	Purple	120"		3/8" Side Support T to Cylinder 3 Bottom	16	079001-120	
H47	Purple	51"		3/8" Side Support T to Cylinder 1 Bottom	16	079001-51	
H48	Black	122"		3/8" Side Support T to Cylinder 3 Top	16	079001-120	
H49	Black	51"		3/8" Side Support T to Cylinder 1 Top	16	079001-51	
H50	Plain	5"		1/2" BX D03 Manifold P to Main D03 P	15, 18		079004-5
H51	Plain	24"		1/2" BX D03 Manifold T to Main D03 T	15, 18		079004-24
H52	White	211"		1/4" BX Toe Board Front Base	18		079000-211
H53	Orange	241"		1/4" BX Toe Board Front Top	18		079000-241
H54	Blue	129"		1/4" BX Toe Board T to Rear Base	18		079000-129
H55	Red	129"		1/4" BX Toe Board T to Rear Top	18		079000-129

8 Hydraulic Information

Hydraulic Hoses BX12

12/6/2019

WM4500 w/BX12 - rev A3.00
Hose List

Wood-Mizer P/N WM4500
Rev. C

Hose List								
ID	Color	Length		Description	XREF	Wood-Mizer Part#		
		Std. Bed	12' Bed Ext.			Standard Bed	12ft. Bed Extensions	
H56	Yellow		229"	3/8" BX Clamp Up/Down Base	18		079001-229	
H57	Green		229"	3/8" BX Clamp Up/Down Top	18		079001-229	
H58	Orange		213"	3/8" BX Clamp In/Out Base	18		079001-213	
H59	White		223"	3/8" BX Clamp In/Out Top	18		079001-223	
H60	Green		144"	1/2" Valve B to Loader Flow Divider	13, 19		079004-144	
H61	Green		120"	1/2" Loader Flow Divider Port 1 to Diverter Port 2	19		079004-120	
H62	Green		120"	1/2" Loader Flow Divider Port 2 to Diverter Port 1	19		079004-120	
H63	Green		240"	1/2" BX Loader T Top	19, 21		079004-240	
H64	Green		72"	3/8" BX Loader T Top to Cylinder Top	21		079001-72	
H65	Green		72"	3/8" BX Loader T Top to Cylinder Top	21		079001-72	
H66	Yellow		144"	1/2" Valve A to Loaders T Base	13, 14		079004-144	
H67	Yellow		120"	1/2" Loaders T Base to BX Loader T Base	14, 21		079004-120	
H68	Yellow		72"	3/8" BX Loader T Base to Cylinder Base	21		079001-72	
H69	Yellow		72"	3/8" BX Loader T Base to Cylinder Base	21		079001-72	
H70	Orange		144"	1/2" Valve A to LD Motors SV Port 2	13, 20		079004-144	
H71	Orange		144"	1/2" LD Motors SV Port 1 to LD Motor Port B Union	20		079004-144	
H72	Orange		192"	1/2" LD Motors SV Port 3 to BX LD Motor Port B	20, 21		079004-192	
H73	White		192"	1/2" LD Motors BV Port 2 to BX LD Motor Port A	20, 21		079004-192	
H75	Plain		24"	3/8" BX Turner FD Port 4 to Turner FD Port 3 T	1		079001-24	
H76	Plain		42"	3/8" Turner FD Port 3 T to BX Turner SV Port 1	19, 20		079001-42	
H77	Plain		42"	3/8" BX Turner FD Port 2 to BX Turner SV Port 2	19, 20		079001-42	
H78	Plain		168"	3/8" Turner FD Port 4 to Cylinder 1 Top Union	19		079001-168	
H79	Plain		168"	3/8" Turner FD Port 2 to Cylinder 2 Top Union	19		079001-168	
H80	Plain		120"	3/8" BX Turner SV Port 3 to BX Turner Top	20, 21		079001-120	
H81	Pink		60"	3/8" Turner Base T to BX Turner Base	13, 21		079001-60	
H82	Black		120"	3/8" Valve B to Side Support FD Port 3	15, 19		079001-120	
H83	Black		42"	3/8" BX Side Support SV Port 1 to FD Port 4 T	19, 20		079001-42	
H84	Black		36"	3/8" BX Side Support SV Port 2 to FD Port 2	19, 20		079001-36	
H85	Black		108"	3/8" BX Side Support BV Port 2 to BX Base T	20, 22		079001-108	
H86	Black		48"	3/8" BX Side Support FD Port 4 to Side Support Union	16, 19		079001-48	
H87	Black		42"	3/8" BX T to BX Cylinder 1 Base	22		079001-42	
H88	Black		80"	3/8" BX T To BX Cylinder 2 Base	22		079001-80	
H89	Purple		144"	3/8" Valve A to BX Side Support T	15, 22		079001-144	
H90	Purple		84"	3/8" BX Side Support T to BX Cylinder 1 Top	22		079001-84	
H91	Purple		122"	3/8" BX Side Support T to BX Cylinder 2 Top	22		079001-122	
H92	Blue		144"	3/8" Valve B to BX PTSR SV Port 1	15, 20		079001-144	
H93	Blue		259"	3/8" BX PTSR Motor B to SV Port 2	18, 20		079001-259	
H94	Red		204"	3/8" BX PTSR SV Port 3 to BX PTSR Motor 1 Port A	18, 20		079001-204	
H95	Blue		204"	3/8" BX PTSR Motor 1 Port B to BV Port 2	18, 20		079001-204	
H96	Black		96"	1/2" Turner Motor (far) to BX SV Port 2	13, 20		079004-96	
H97	Black		96"	1/2" Valve A to BX SV Port 1	13, 20		079004-96	
H98	Black		178"	1/2" BX Turner Motor Port B to BV Port 2	20, 21		079004-178	
H99	Purple		178"	1/2" BX Turner Motor Port A to SV Port 3	20, 21		079004-178	
H108	Black	44"		1/2" Pull Down D03 Manifold P to Main D03 P	15, 17	079004-44		
H109	Black	36"		1/2" Pull Down D03 Manifold T to Main D03 T	15, 17	079004-36		
H110	Black	456"		1/4" Pull Down Clamp 1 Up/Dn Base to Valve 1 A	17	079000-456		
H111	Black	456"		1/4" Pull Down Clamp 1 Up/Dn Top to Valve 1 B	17	079000-456		
H112	Black	456"		1/4" Pull Down Clamp 1 In/Out Base to Vavle 2 B	17	079000-456		
H113	Black	456"		1/4" Pull Down Clamp 1 In/Out Top to Vavle 2 A	17	079000-456		
H114	Black	336"		1/4" Pull Down Clamp 2 Up/Dn Base to Valve 3 A	17	079000-336		
H115	Black	336"		1/4" Pull Down Clamp 2 Up/Dn Top to Valve 3 B	17	079000-336		
H116	Black	336"		1/4" Pull Down Clamp 2 In/Out Base to Vavle 4 B	17	079000-336		

12/6/2019

WM4500 w/BX12 - rev A3.00
 Hose List

Wood-Mizer P/N WM4500
 Rev. C

Hose List							
ID	Color	Length		Description	XREF	Wood-Mizer Part#	
		Std. Bed	12' Bed Ext.			Standard Bed	12ft. Bed Extensions
H117	Black	336"		1/4" Pull Down Clamp 2 In/Out Top to Vavle 4 A	17	079000-336	
H133	Purple	41"		3/8" SD Support 1 Top T to SD Support 2 Top T	16	079001-41	
H134	Black	41"		3/8" SD Support 1 Base T to SD Support 2 Base T	16	079001-41	
H135	Purple	55"		3/8" SD Support 1 Top T to SD Support 2 Top	16	079001-55	
H136	Black	59"		3/8" SD Support 1 Base T to SD Support 2 Base	16	079001-59	

8.9 Hydraulic Hoses Double Bed

Hose List							
ID	Color	Length		Description	XREF	Wood-Mizer Part#	
		Std. Bed	Full Bed Ext.			Standard Bed	12ft. Bed Extensions
H1	Steel Line/Hose			Tube, 1-1/4" Suction to Pump	12		078736
H2	Steel Line/Hose			Tube, 1/4" Hyd. Load Sense	12		078761
H3	Steel Line/Hose			Tube, 3/4" Hyd. Prop to Relief	12		078760
H4	N/A	N/A	N/A	Hose, 1/2" Case Drain	12		078767
H5	Steel Line/Hose			Tube, 1-1/4" Filter to Tank	12		078764
H6	Steel Line/Hose			Tube, 3/4" Hyd. Prop to Mfld1	12, 13		078762
H7	Steel Line/Hose			Tube, 1" Hyd. Mfld1 to Filter	12, 13		078765
H8	Steel Line/Hose			Tube, 3/4" Hyd. Mfld1 to Mfld2 Pressure	13, 15		078763
H9	Steel Line/Hose			Tube, 1" Hyd. Mfld2 to Filter	12, 15		078766
H10	Blue	471"	264"	1/2" Conveyor Motor Return	13	079004-471	079004-264
H11	Red	471"	264"	1/2" Conveyor Motor Drive	13	079004-471	079004-264
H12	Red	156"		1/2" Bed Conveyor Motor to Incline Conveyor Motor	13	079004-156	
H13	Blue	156"		1/2" Incline Conveyor Motor Return	13	079004-156	
H14	Black	334"		1/2" Turner (near) Motor	13	079004-334	
H15	Plain	132"		1/2" Turner Motor (near) to Turner Motor (far)	13	079004-132	
H16	Purple	350"	264"	1/2" Turner (far) Motor	13	079004-350	079004-264
H17	Green	310"		1/2" Loader T Top	14, 20	079004-310	
H18	Yellow	310"		1/2" Loader T Base	14	079004-310	
H19	Green	72"		3/8" Loader T Top to Cylinder Top	14	079001-72	
H20	Green	72"		3/8" Loader T Top to Cylinder Top	14	079001-72	
H21	Yellow	72"		3/8" Loader T Base to Cylinder Base	14	079001-72	
H22	Yellow	72"		3/8" Loader T Base to Cylinder Base	14	079001-72	
H23	Orange	310"		1/2" Log Deck Motor B	14, 21	079004-310	
H24	White	310"	264"	1/2" Log Deck Motor A	13, 14	079004-310	079004-264
H25	Orange	364"	264"	3/8" Clamp In/Out Base	15, 16	079001-364	079001-264
H26	White	364"	264"	3/8" Clamp In/Out Top	15, 16	079001-364	079001-264
H27	Pink	275"		3/8" Turner T Base	13, 22	079001-275	
H28	Plain	85"		3/8" Turner Flow Divider	15, 20	079001-85	
H29	Pink	19"		3/8" Turner T Base to Cylinder 1 Base	13	079001-19	
H30	Pink	39"		3/8" Turner T Base to Cylinder 2 Base	13	079001-39	
H31	Plain	200"		3/8" Turner Flow Divider to Cylinder 1 Top	13, 20	079001-200	
H32	Plain	216"		3/8" Turner Flow Divider to Cylinder 2 Top	13, 20	079001-216	
H33	Yellow	364"	264"	3/8" Clamp Up/Down Base	15, 16	079001-364	079001-264
H34	Green	364"	264"	3/8" Clamp Up/Down Top	15, 16	079001-364	079001-264
H35	Grey	267"	264"	1/4" Toe Board 1 Base	15	079000-267	079000-264
H36	Yellow	270"	264"	1/4" Toe Board 1 Top	15	079000-270	079000-264
H37	Red	276"	264"	3/8" PTSR 1 Motor A	15	079001-276	079001-264
H38	Blue	348"		3/8" PTSR 2 Motor B	15, 18	079001-348	
H39	Plain	154"		3/8" PTSR 1 Motor B to PTSR 2 Motor A	15	079001-154	
H40	Black	333"	264"	1/4" Toe Board 2 Base	15	079000-333	079000-264
H41	Purple	335"	264"	1/4" Toe Board 2 Top	15	079000-335	079000-264
H42	Blue		468"	1/4" Toe Board 3 Base	15, 18		079000-468
H43	Red		468"	1/4" Toe Board 3 Top	15, 18		079000-468
H44	Purple	190"		3/8" Side Support T 1 Bottom	16, 23	079001-190	
H45	Black	190"		3/8" Side Support T 1 Top	16	079001-190	
H46	Purple	120"		3/8" Side Support T to Cylinder 3 Bottom	16	079001-120	
H47	Purple	51"		3/8" Side Support T to Cylinder 1 Bottom	16	079001-51	
H48	Black	122"		3/8" Side Support T to Cylinder 3 Top	16	079001-122	
H49	Black	51"		3/8" Side Support T to Cylinder 1 Top	16	079001-51	
H50	Plain		5"	1/2" BX D03 Manifold P to Main D03 P	15, 18		079004-5
H51	Plain		24"	1/2" BX D03 Manifold T to Main D03 T	15, 18		079004-24

Hose List							
ID	Color	Length		Description	XREF	Wood-Mizer Part#	
		Std. Bed	Full Bed Ext.			Standard Bed	12ft. Bed Extensions
H52	White		360"	1/4" BX Toe Board Base T	18		079000-360
H53	Orange		360"	1/4" BX Toe Board Top T	18		079000-360
H54	Blue		132"	1/4" BX Toe Board T to Rear Base	18		079000-132
H55	Red		132"	1/4" BX Toe Board T to Rear Top	18		079000-132
H56	Yellow		364"	3/8" BX Clamp Up SV Port 3 to BX Clamp 2 Cyl Base	19		079001-364
H57	Green		364"	3/8" BX Clamp Dn SV Port 3 to BX Clamp 2 Cyl Top	19		079001-364
H58	Orange		364"	3/8" BX Clamp In SV Port 3 to BX Clamp 2 Cyl Base	19		079001-364
H59	White		364"	3/8" BX Clamp Out SV Port 3 to BX Clamp 2 Cyl Top	19		079001-364
H60	Green		264"	1/2" Valve B to Loader Flow Divider	13, 20		079004-264
H61	Green		240"	1/2" Loader Flow Divider Port 1 to Diverter Port 2	20		079004-240
H62	Green		240"	1/2" Loader Flow Divider Port 2 to Diverter Port 1	20		079004-240
H63	Green		360"	1/2" BX Loader T Top tp BV Port 2	20, 22		079004-240
H64	Green		72"	3/8" BX Loader T Top to Cylinder Top	22		079001-72
H65	Green		72"	3/8" BX Loader T Top to Cylinder Top	22		079001-72
H66	Yellow		264"	1/2" Valve A to Loaders T Base	13, 14		079004-264
H67	Yellow		120"	1/2" Loaders T Base to BX Loader T Base	14, 22		079004-120
H68	Yellow		72"	3/8" BX Loader T Base to Cylinder Base	22		079001-72
H69	Yellow		72"	3/8" BX Loader T Base to Cylinder Base	22		079001-72
H70	Orange		144"	1/2" Valve A to LD Motors SV Port 2	13, 21		079004-144
H71	Orange		264"	1/2" LD Motors SV Port 1 to LD Motor Port B Union	21		079004-264
H72	Orange		312"	1/2" LD Motors SV Port 3 to BX LD Motor Port B	21, 22		079004-312
H73	White		312"	1/2" LD Motors BV Port 2 to BX LD Motor Port A	21, 22		079004-312
H74	Pink		65"	3/8" BX Turner 1 T Base to BX Turner 2 T Base	22		079001-65
H75	Plain		24"	3/8" BX Turner FD Port 4 to Turner FD Port 3 T	20		079001-24
H76	Plain		42"	3/8" Turner FD Port 3 T to BX Turner SV Port 1	20, 21		079001-42
H77	Plain		42"	3/8" BX Turner FD Port 2 to BX Turner SV Port 2	20, 21		079001-42
H78	Plain		288"	3/8" Turner FD Port 4 to Cylinder 1 Top Union	20		079001-288
H79	Plain		288"	3/8" Turner FD Port 2 to Cylinder 2 Top Union	20		079001-288
H80	Plain		48"	3/8" BX Turner SV Port 3 to BX Turner Top	21		079001-120
H81	Pink		240"	3/8" Valve A BX Turner Base T	15, 22		079001-60
H82	Black		120"	3/8" Valve B to Side Support FD Port 3	15, 20		079001-120
H83	Black		42"	3/8" BX Side Support SV Port 1 to FD Port 4 T	20, 21		079001-42
H84	Black		36"	3/8" BX Side Support SV Port 2 to FD Port 2	20, 21		079001-36
H85	Black		300"	3/8" BX Side Support BV Port 2 to BX Base T	21, 23		079001-300
H86	Black		180"	3/8" BX Side Support FD Port 4 to Side Support Union	16, 20		079001-180
H87	Black		78"	3/8" BX T to BX Cylinder 3 Top	23		079001-78
H88	Black		54"	3/8" BX T To BX Cylinder 1 Top	23		079001-54
H89	Purple		240"	3/8" Valve A to BX Side Support T	15, 23		079001-240
H90	Purple		54"	3/8" BX Side Support T to BX Cylinder 3 Bottom	23		079001-54
H91	Purple		54"	3/8" BX Side Support T to BX Cylinder 1 Bottom	23		079001-54
H92	Blue		144"	3/8" Valve B to BX PTSR SV Port 1	15, 21		079001-144
H93	Blue		420"	3/8" BX PTSR Motor 3 Port B to SV Port 2	18, 21		079001-420
H94	Red		276"	3/8" BX PTSR SV Port 3 to BX PTSR Motor 1 Port A	18, 21		079001-276
H95	Blue		348"	3/8" BX PTSR Motor 1 Port B to BV Port 2	18, 21		079001-348
H96	Black		216"	1/2" Turner Motor (far) to BX SV Port 2	13, 21		079004-96
H97	Black		96"	1/2" Valve A to BX SV Port 1	13, 21		079004-96
H98	Black		360"	1/2" BX Turner Far Motor Port B to BV Port 2	21, 22		079004-360
H99	Purple		360"	1/2" BX Turner Near Motor Port A to SV Port 3	21, 22		079004-360
H100	Black	48"		3/8" Pop Up Stop SV A Port 2		079001-48	
H101	Purple	48"		3/8" Pop Up Stop SV B Port 2		079001-48	
H102	Black	224"		3/8" Pop Up Stop SV A Port 3 to T		079001-224	

Hose List							
ID	Color	Length		Description	XREF	Wood-Mizer Part#	
		Std. Bed	Full Bed Ext.			Standard Bed	12ft. Bed Extensions
H103	Purple	224"		3/8" Pop Up Stop SV B Port 3 to T		079001-224	
H104	Black	48"		3/8" Pop Up Stop T to Cylinder 1 Top		079001-48	
H105	Black	48"		3/8" Pop Up Stop T to Cylinder 2 Top		079001-48	
H106	Purple	48"		3/8" Pop Up Stop T to Cylinder 1 Bottom		079001-48	
H107	Purple	48"		3/8" Pop Up Stop T to Cylinder 2 Bottom		079001-48	
H108	Black	44"		1/2" Pull Down D03 Manifold P to Main D03 P	15, 17	079004-44	
H109	Black	36"		1/2" Pull Down D03 Manifold T to Main D03 T	15, 17	079004-36	
H110	Black	456"		1/4" Pull Down Clamp 1 Up/Dn Base to Valve 1 A	17	079000-456	
H111	Black	456"		1/4" Pull Down Clamp 1 Up/Dn Top to Valve 1 B	17	079000-456	
H112	Black	456"		1/4" Pull Down Clamp 1 In/Out Base to Vavle 2 B	17	079000-456	
H113	Black	456"		1/4" Pull Down Clamp 1 In/Out Top to Vavle 2 A	17	079000-456	
H114	Black	336"		1/4" Pull Down Clamp 2 Up/Dn Base to Valve 3 A	17	079000-336	
H115	Black	336"		1/4" Pull Down Clamp 2 Up/Dn Top to Valve 3 B	17	079000-336	
H116	Black	336"		1/4" Pull Down Clamp 2 In/Out Base to Valve 4 B	17	079000-336	
H117	Black	336"		1/4" Pull Down Clamp 2 In/Out Top to Valve 4A	17	079000-336	
H118	Pink		84"	3/8" Turner T Base to Cylinder 3 Base	22		079001-84
H119	Pink		84"	3/8" Turner T Base to Cylinder 4 Base	22		079001-84
H120	Black		216"	3/8" Turner Flow Divinder to Cylinder 3 Top	21, 22		079001-216
H121	Black		288"	3/8" Turner Flow Divinder to Cylinder 4 Top	21, 22		079001-288
H122	Black		180"	1/2" BX Turner Motor (near) to BX Turner Motor (far)	22		079004-180
H123	Yellow		144"	3/8" BX Clamp Up/Dn Valve A to Up SV Port 2	18, 19		079001-144
H124	Green		144"	3/8" BX Clamp Up/Dn Valve B to Dn SV Port 2	18, 19		079001-144
H125	Orange		144"	3/8" BX Clamp In/Out Valve A to In SV Port 2	18, 19		079001-144
H126	White		144"	3/8" BX Clamp In/Out Valve B to Out SV Port 2	18, 19		079001-144
H127	Yellow		364"	3/8" BX Clamp Up SV Port 1 to BX Clamp 1 Cyl Base	19		079001-364
H128	Green		364"	3/8" BX Clamp Dn SV Port 1 to BX Clamp 1 Cyl Top	19		079001-364
H129	Orange		364"	3/8" BX Clamp In SV Port 1 to BX Clamp 1 Cyl Base	19		079001-364
H130	White		364"	3/8" BX Clamp Out SV Port 1 to BX Clamp 1 Cyl Top	19		079001-364
H132	Black		154"	3/8" BX PTRS 1 Motor B to PTRS 2 Motor A	18		079001-154
H133	Purple		41"	3/8" SD Support 1 Top T to SD Support 2 Top T	16	079001-41	
H134	Black		41"	3/8" SD Support 1 Base T to SD Support 2 Base T	16	079001-41	
H135	Purple		55"	3/8" SD Support 1 Top T to SD Support 2 Top	16	079001-55	
H136	Black		59"	3/8" SD Support 1 Base T to SD Support 2 Base	16	079001-59	
H137	Blue		24"	1/4" BX Toe Board Base T to Cylinder 1 Base	18		079000-24
H138	Red		24"	1/4" BX Toe Board Top T to Cylinder 1 Top	18		079000-24
H139	Black		48"	3/8" BX SD Sup Top T1 to T2	23		079001-48
H140	Purple		48"	3/8" BX SD Sup Bottom T1 to T2	23		079001-48
H141	Black		54"	3/8" BX SD Sup Top T2 to Cylinder 2 Top	23		079001-54
H142	Purple		54"	3/8" BX SD Sup Bottom T2 to Cylinder 2 Bottom	23		079001-54
H143	Purple		60"	3/8" BX SD Sup Bottom T2 to T3	23		079001-60

A

alignment

- align side supports 7
- bed frame length 1
- bed frame width 2
- level bed rails 6
- level saw head 38, 3
- standard block/roller guides
 - blade guide 17
 - blade guide arm 15
 - blade guide overview 9
 - blade guide preparation 11
 - blade wheel vertical tilt 13

B

belt

- tension 18

C

chain

- feed tension 15
- maintenance 6
- turner tension 21

E

electrical installation

- blade motor cable 20
- head box cable 24

H

hydraulic

- component ID 59, 61, 64
- hoses 68, 70, 73

M

maintenance

- blade guide 1
- blade guides 2
- blade wheel bearings/scrapers 11
- drive belt 18
- hydraulic system 10
- miscellaneous 6
- power feed 15
- proximity sensors 8
- sawdust removal 3
- track rails/scrapers 4
- turner chain 21
- up/down 11

up/down system 12

O

operation

control overview 1

distribution box overview 3

installing a blade 28

joystick overview 4

loading a log 33

programming the control 12

 select language 17

 system setup 12

sawing the log 36

setworks overview 1

starting the machine 27

S

safety

lockout procedure 7

Safety Instructions 1

Safety Symbols 1, 2

service info

customer/sawmill ID 1

setup

air installation 35

blade lube installation 26

electrical installation 15, 25

final sawmill 36

hydraulic installation 28

hydraulic log clamp installation 6

initial control programming 47, 33

level bed rails 42

level blade guide arm 43

operator station installation 2

sawmill installation 4