

APPENDIX A ELECTRICAL INFORMATION

WM4500 Full Bed Extension Rev. 4.04+

Table of contents

WM_TableOfContents

Page	Page type	Page description	Date	Edited by
&MEA/A1	Table of contents	Table of contents	3/1/2021	JRF
&MEA/A2	Table of contents	Table of contents	3/1/2021	JRF
&MEA/B1	Overview	Revision History	2/10/2021	JRF
&MEA+L1.L3/1	Schematic multi-line	Power Pg 1	3/1/2021	JRF
&MEA+L1.L3/2	Schematic multi-line	Power Pg 2	2/10/2021	JRF
&MEA+L1.L3/3	Schematic multi-line	Power Pg 3	2/24/2021	JRF
&MEA+L1.L3/4	Schematic multi-line	Control Pg 1	2/10/2021	JRF
&MEA+L1.L3/5	Schematic multi-line	Control Pg 2	2/10/2021	JRF
&MEA+L1.L3/6	Schematic multi-line	Control Pg 3	2/10/2021	JRF
&MEA+L1.L4/7	Schematic multi-line	Control Pg 4	2/10/2021	JRF
&MEA+L1.L4/8	Schematic multi-line	Control Pg 5	2/10/2021	JRF
&MEA+L1.L4/9	Schematic multi-line	Control Pg 6	2/10/2021	JRF
&MEA+L1.L4/10	Schematic multi-line	Control Pg 7	2/10/2021	JRF
&MEA+L1.L4/11	Schematic multi-line	Control Pg 8	3/1/2021	JRF
&MEA+L1.L4/12	Schematic multi-line	Control Pg 9	2/10/2021	JRF
&MEA+L1.L4/13	Schematic multi-line	Control Pg 10	3/1/2021	JRF
&MEA+L1.L4/14	Schematic multi-line	Control Pg 11	3/1/2021	JRF
&MEA+L1.L4/15	Schematic multi-line	Control Pg 12	2/10/2021	JRF
&MEA+L1.L4/16	Schematic multi-line	Control Pg 13	2/24/2021	JRF
&MEA+L1.L4/17	Schematic multi-line	Control Pg 14	2/24/2021	JRF
&MEA+L1.L4/18	Schematic multi-line	Control Pg 15	2/10/2021	JRF
&MEA+L1.L4/19	Schematic multi-line	Communication	2/24/2021	JRF
&MEA+L1.L4/20	Panel layout	PLC Diagram	2/10/2021	JRF
&MEA+L1.L4/21	Schematic multi-line	PLC 1	2/10/2021	JRF
&MEA+L1.L4/22	Schematic multi-line	PLC 2	2/24/2021	JRF
&MEA+L1.L4/23	Schematic multi-line	PLC 3	2/10/2021	JRF
&MEA+L1.L4/24	Schematic multi-line	PLC 4	2/10/2021	JRF
&MEA+L1.L4/25	Schematic multi-line	PLC 5	2/10/2021	JRF
&MEA+L1.L4/26	Schematic multi-line	PLC 6	2/10/2021	JRF
&MEA+L1.L4/27	Schematic multi-line	PLC 7	2/10/2021	JRF
&MEA+L1.L4/28	Schematic multi-line	PLC 8	2/10/2021	JRF
&MEA+L1.L4/29	Schematic multi-line	PLC 9	2/10/2021	JRF
&MEA+L1.L4/30	Schematic multi-line	PLC 10	2/10/2021	JRF
&MEA+L1.L4/31	Schematic multi-line	PLC 11	2/10/2021	JRF
&MEA+L1.L4/32	Schematic multi-line	PLC 12	2/10/2021	JRF
&MEA+L1.L4/33	Schematic multi-line	PLC 13	2/10/2021	JRF
&MEA+L1.L4/34	Schematic multi-line	PLC 14	2/10/2021	JRF
&MEA+L1.L4/35	Schematic multi-line	PLC 15	2/10/2021	JRF

		Wood-Mizer®	
Project Description: WM4500 Bed Extension Full			
Revision:	A3.05	Pg Desc: Table of contents	
Mounting Location: +		Type: Table of contents	
Prev. pg:	Page: A1	Next pg: A2	Total Pgs: 93

Revision History

Date	Revision	Revision Record	Drawn By	Checked By
8/6/18	A1.00	Release to production	JRF	SDC
4/26/19	A2.00	Added Pull Down Clamp Functions	JRF	SDC
12/6/19	A3.00	Full Bed Extension	JRF	SDC
2/14/24	A4.03	Blade Motor Soft Start (SSD1) - OBS of 069933 replaced with 069933-A1	MM	JRF
4/25/24	A4.04	Modbus network update for termination resistor	JRF	***

		Wood-Mizer®	
Project Description: WM4500 Bed Extension Full			
Revision: A4.04		Pg Desc: Revision History	
Mounting Location: +		Type: Overview	
Prev. pg: A2	Page: B1	Next pg: +L1.L3/1	Total Pgs: 94

Voltage	480VAC +4/-10%
Phase	3Ph
Frequency	60 Hz
FLA Machine	94.1A
FLA Largest Load	38A
Wiring Diagram	
SCCR	5kA

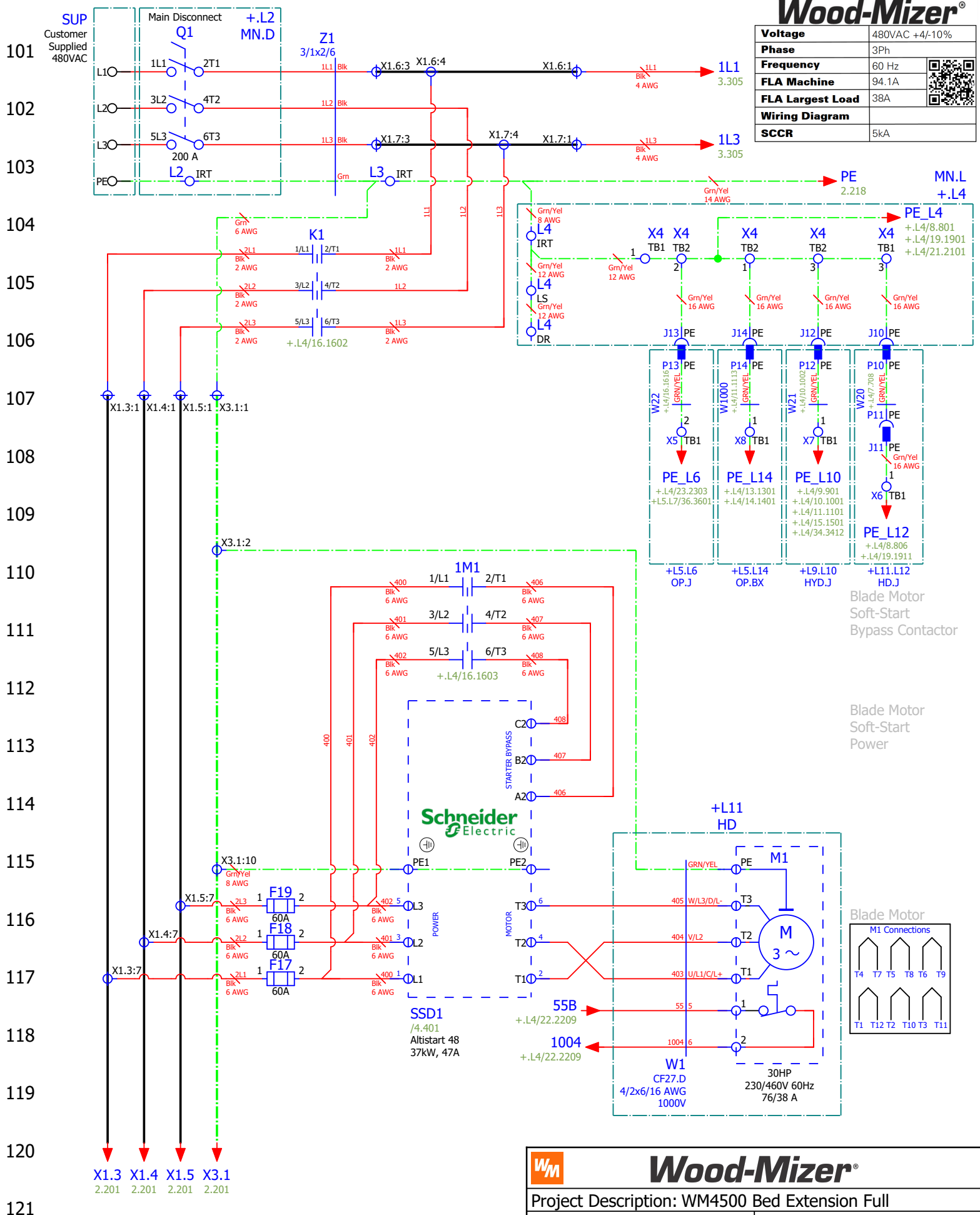

Blade Motor
Soft-Start
Bypass Contactor

Blade Motor
Soft-Start
Power

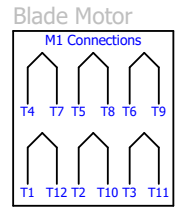

Wood-Mizer®

Project Description: WM4500 Bed Extension Full			
Revision:	A3.05	Pg Desc: Power Pg 1	
Mounting Location:	+L1.L3	Type: Schematic multi-line	
Prev. pg:	+/B1	Page:	1
		Next pg:	2
		Total Pgs:	93

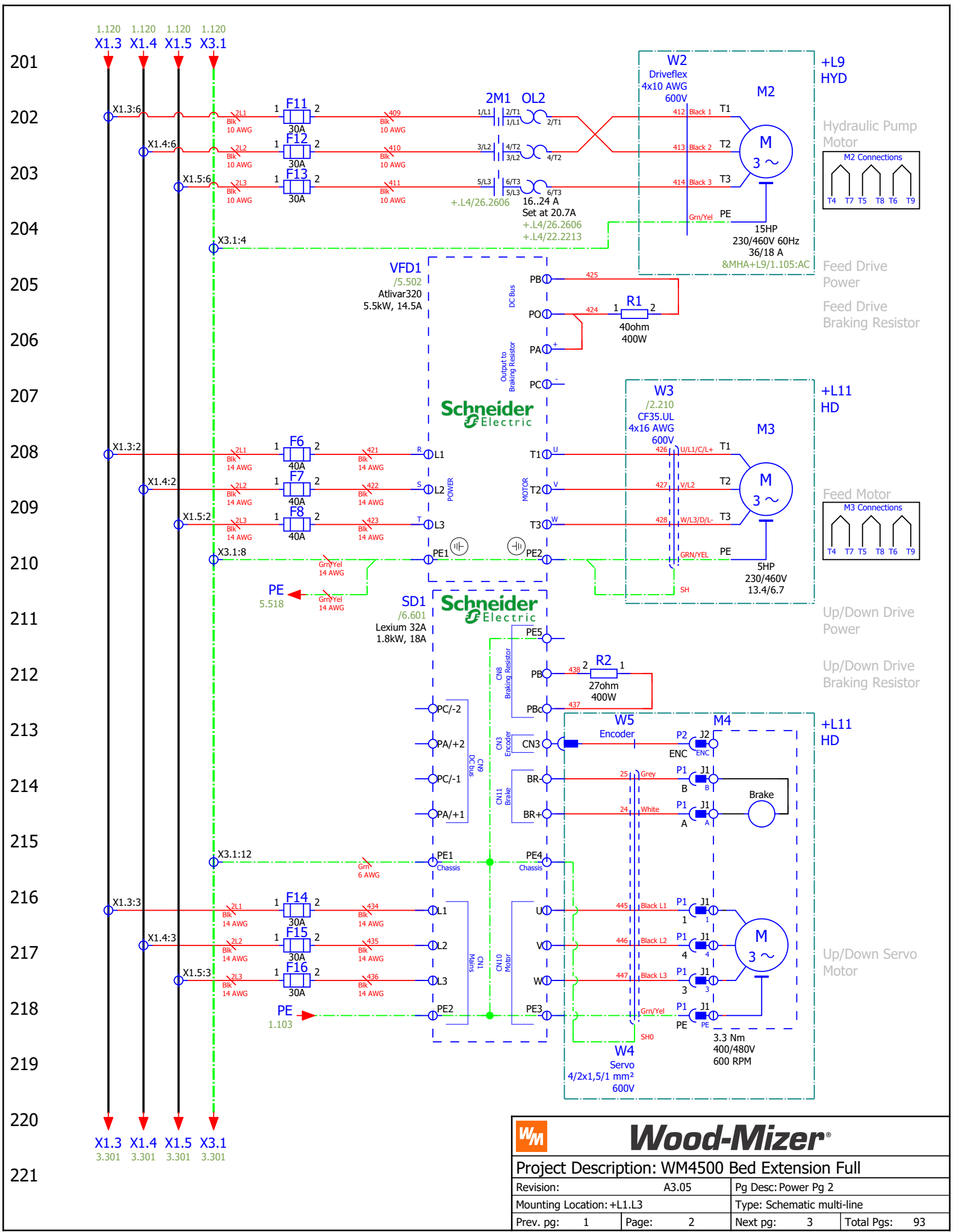

Wood-Mizer			
Project Description: WM4500 Bed Extension Full			
Revision:	A3.05	Pg Desc: Power Pg 2	
Mounting Location:	+L1.L3	Type: Schematic multi-line	
Prev. pg:	1	Page:	2
		Next pg:	3
		Total Pgs:	93

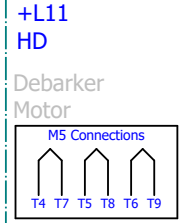
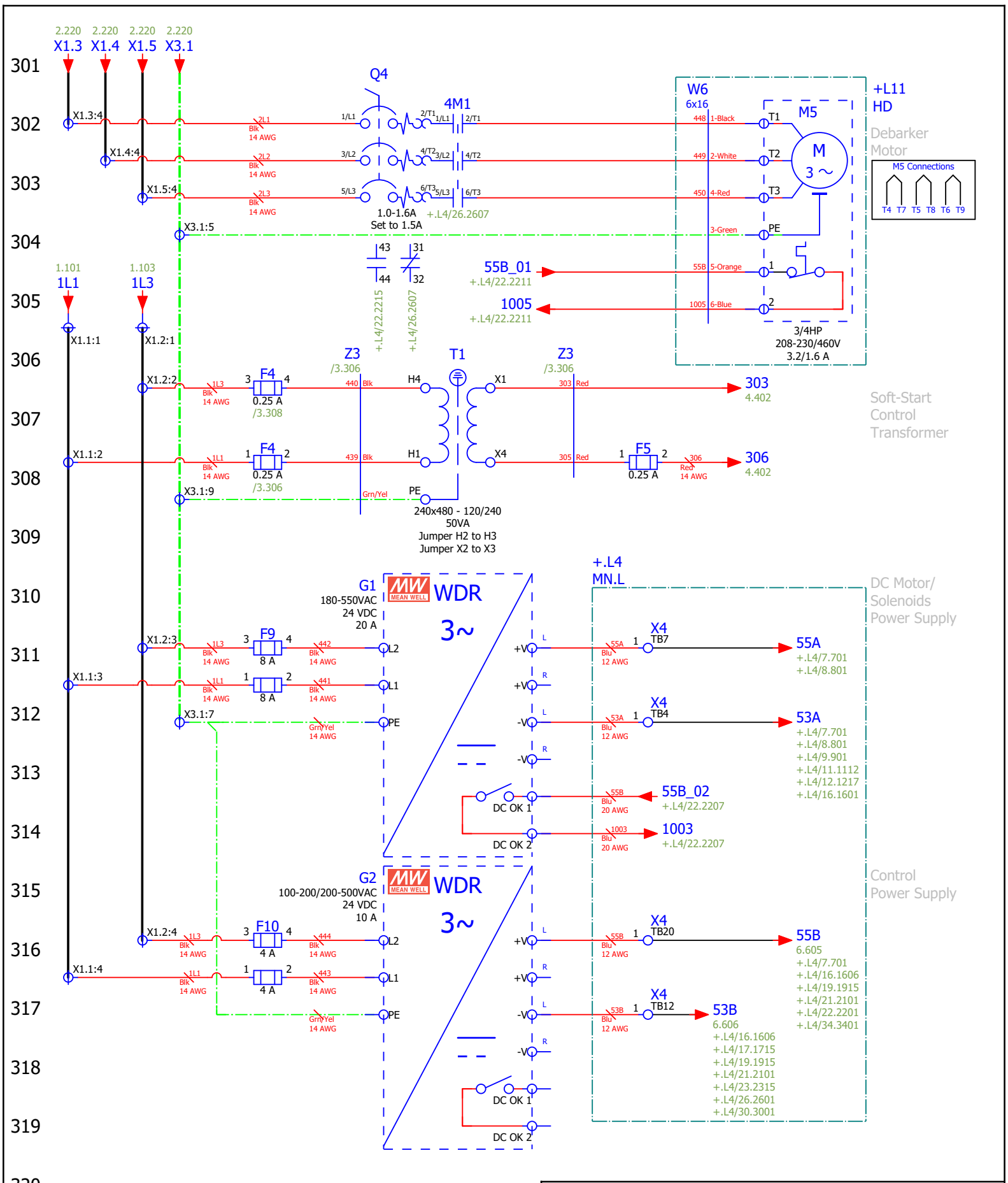

Soft-Start Control Transformer

DC Motor/Solenoids Power Supply

Control Power Supply

Wood-Mizer®			
Project Description: WM4500 Bed Extension Full			
Revision:	A3.05	Pg Desc: Power Pg 3	
Mounting Location:	+L1.L3	Type: Schematic multi-line	
Prev. pg:	2	Page:	3
		Next pg:	4
		Total Pgs:	93

401
402
403
404
405
406
407
408
409
410
411
412
413
414
415
416
417
418
419
420
421

Soft-Start Control

SSD1 /1.112
Altistart 48
37kW, 47A

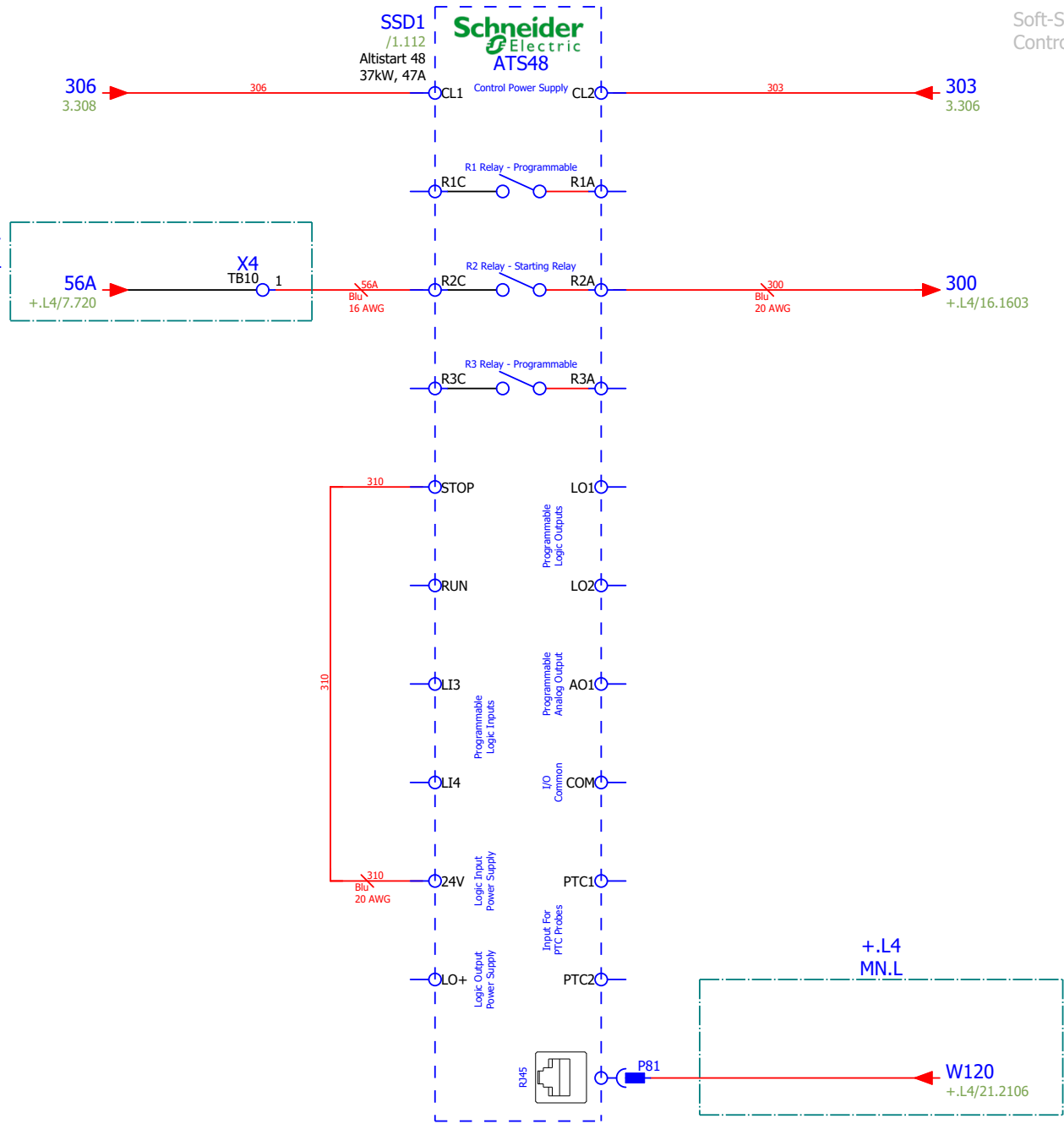

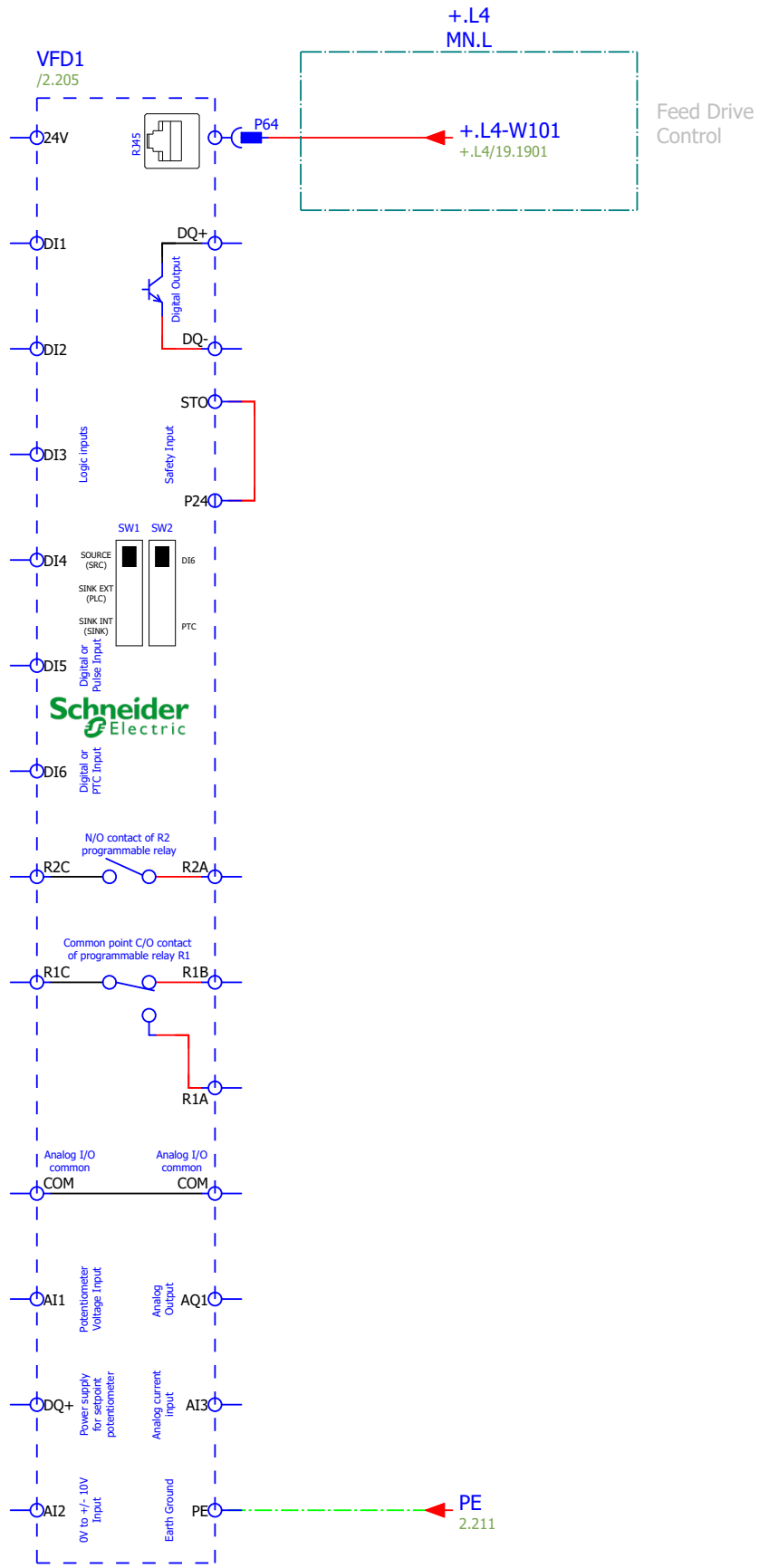

		Wood-Mizer®	
Project Description: WM4500 Bed Extension Full			
Revision:	A3.05	Pg Desc: Control Pg 1	
Mounting Location: +L1.L3		Type: Schematic multi-line	
Prev. pg:	3	Page:	4
		Next pg:	5
		Total Pgs:	93

501
502
503
504
505
506
507
508
509
510
511
512
513
514
515
516
517
518
519
520
521



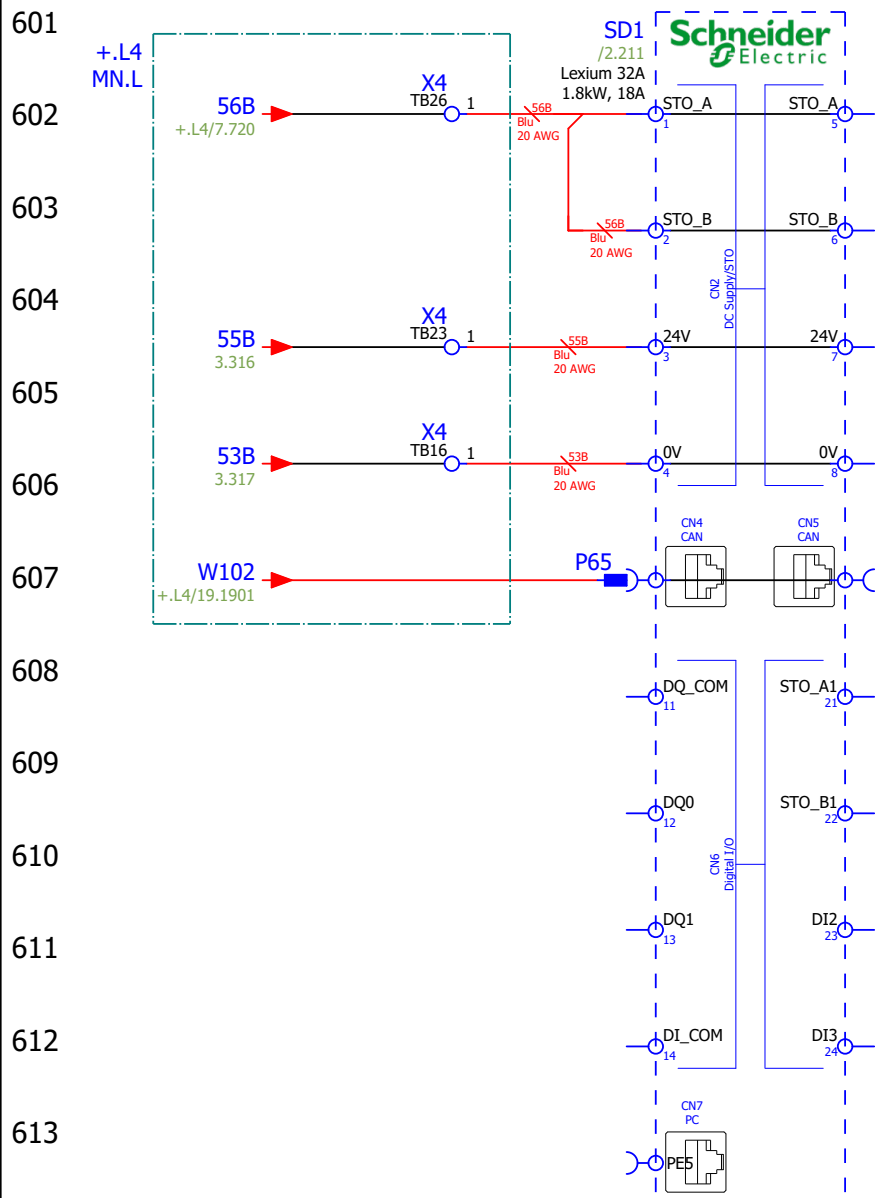

		Wood-Mizer®	
Project Description: WM4500 Bed Extension Full			
Revision:	A3.05	Pg Desc: Control Pg 2	
Mounting Location: +L1.L3		Type: Schematic multi-line	
Prev. pg:	4	Page:	5
Next pg:		6	Total Pgs: 93

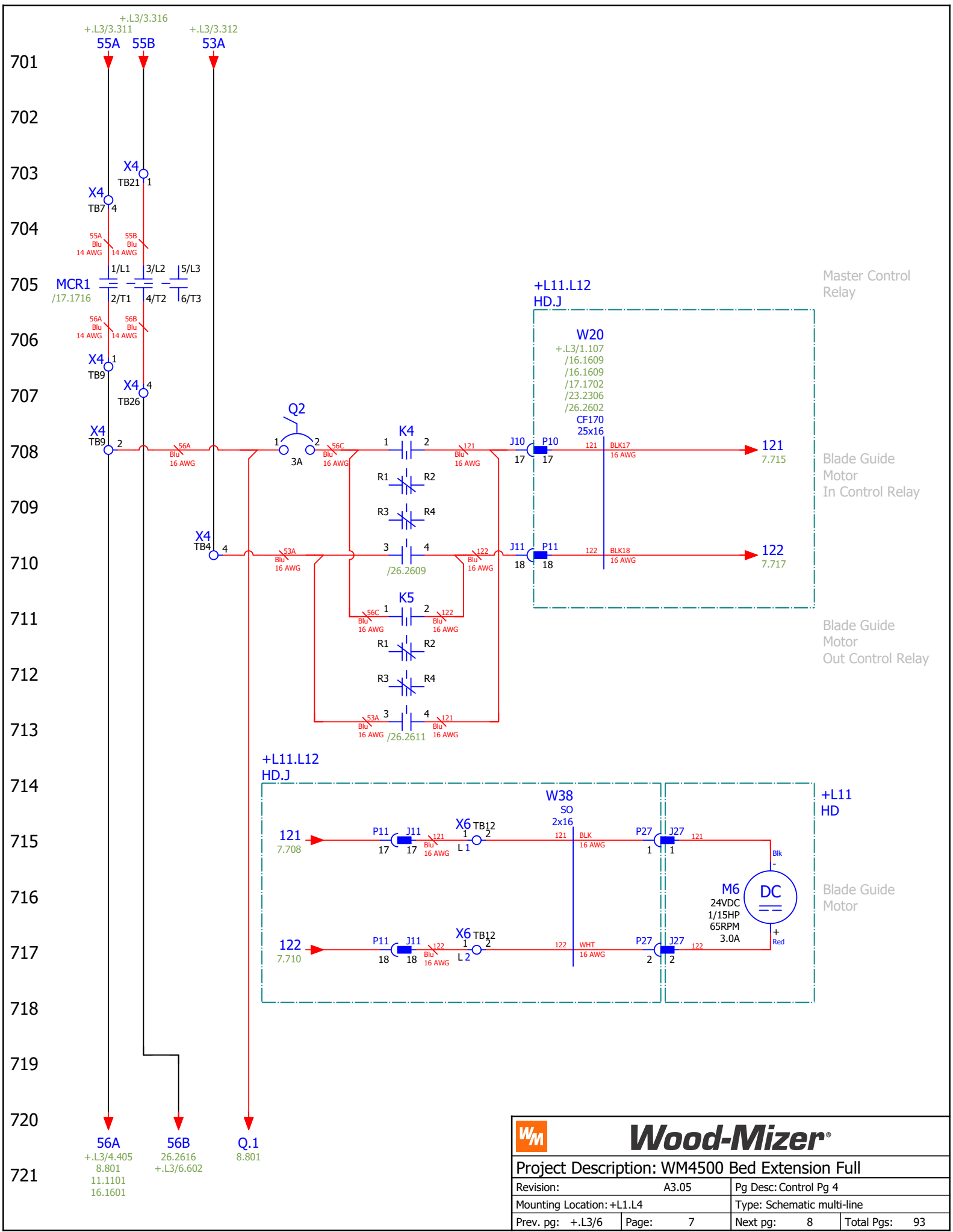

 Wood-Mizer®		Project Description: WM4500 Bed Extension Full	
		Revision: A3.05	Pg Desc: Control Pg 3
Mounting Location: +L1.L3		Type: Schematic multi-line	
Prev. pg: 5	Page: 6	Next pg: +.L4/7	Total Pgs: 93

601
602
603
604
605
606
607
608
609
610
611
612
613
614
615
616
617
618
619
620
621



 Wood-Mizer®			
Project Description: WM4500 Bed Extension Full			
Revision:	A3.05	Pg Desc: Control Pg 4	
Mounting Location:	+L1.L4		Type: Schematic multi-line
Prev. pg:	+L3/6	Page:	7
		Next pg:	8
		Total Pgs:	93

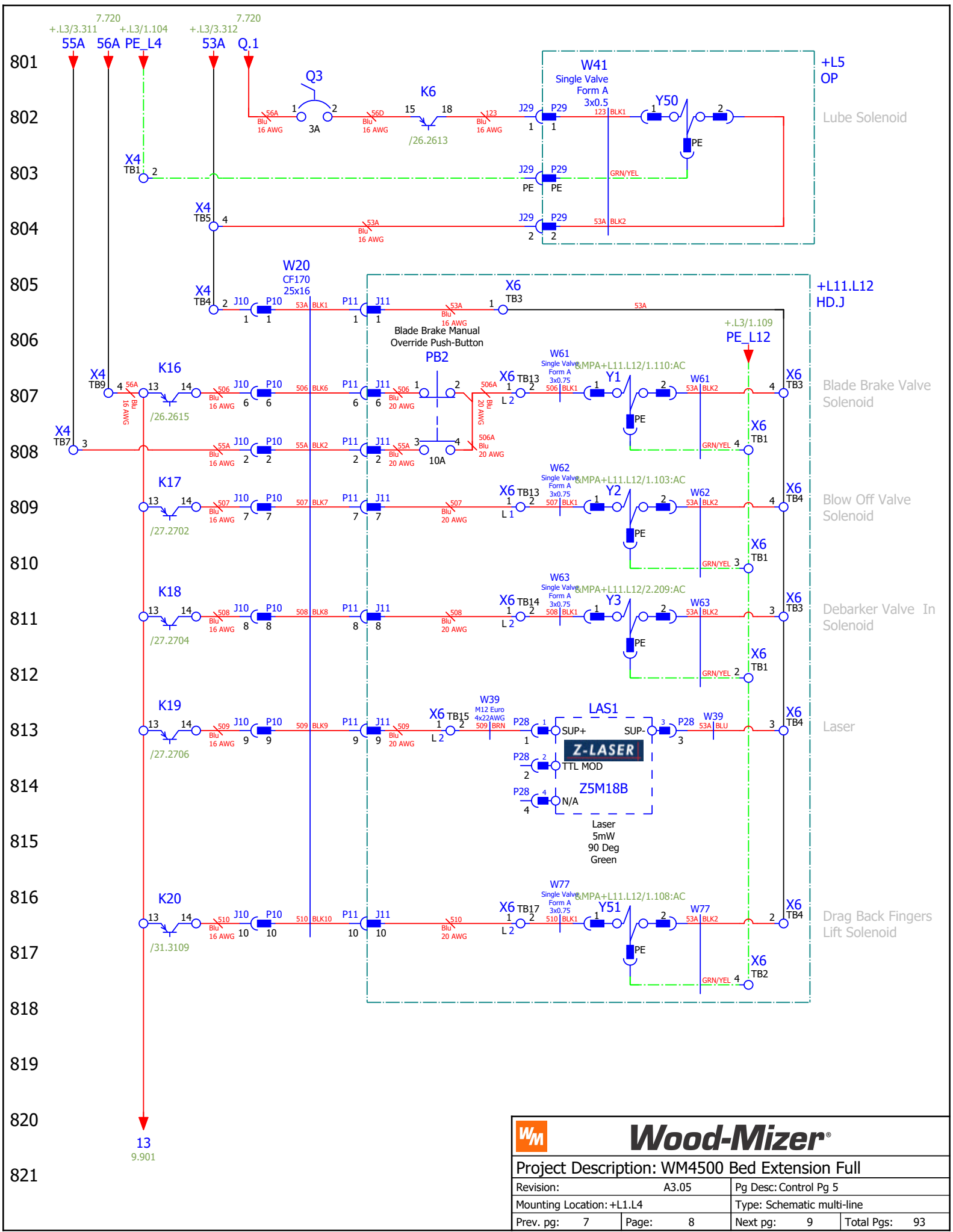

Wood-Mizer®

Project Description: WM4500 Bed Extension Full

Revision: A3.05	Pg Desc: Control Pg 5
Mounting Location: +L1.L4	Type: Schematic multi-line
Prev. pg: 7	Page: 8
	Next pg: 9
	Total Pgs: 93

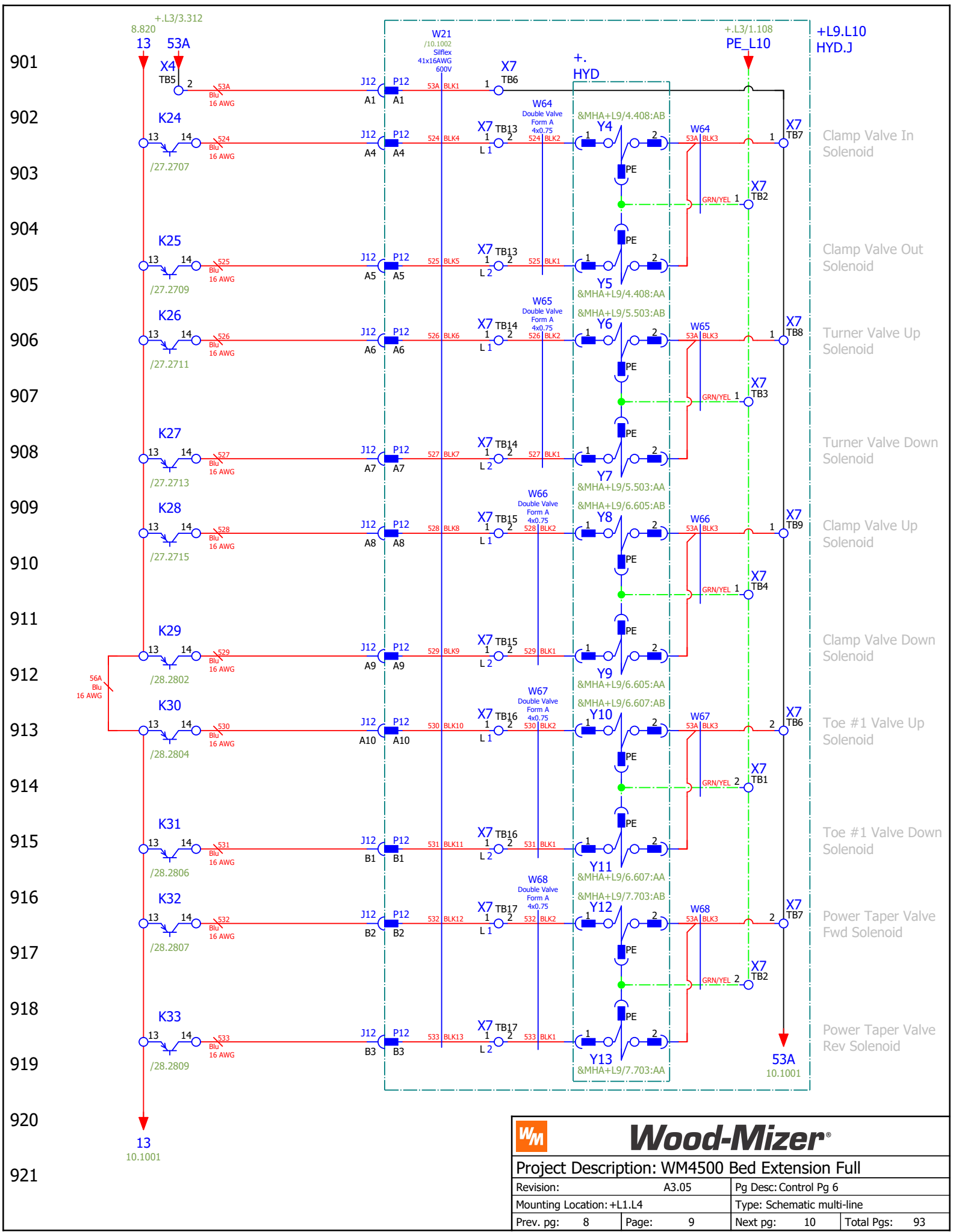

 Wood-Mizer®			
Project Description: WM4500 Bed Extension Full			
Revision:	A3.05	Pg Desc: Control Pg 6	
Mounting Location:	+L1.L4	Type: Schematic multi-line	
Prev. pg:	8	Page:	9
		Next pg:	10
		Total Pgs:	93

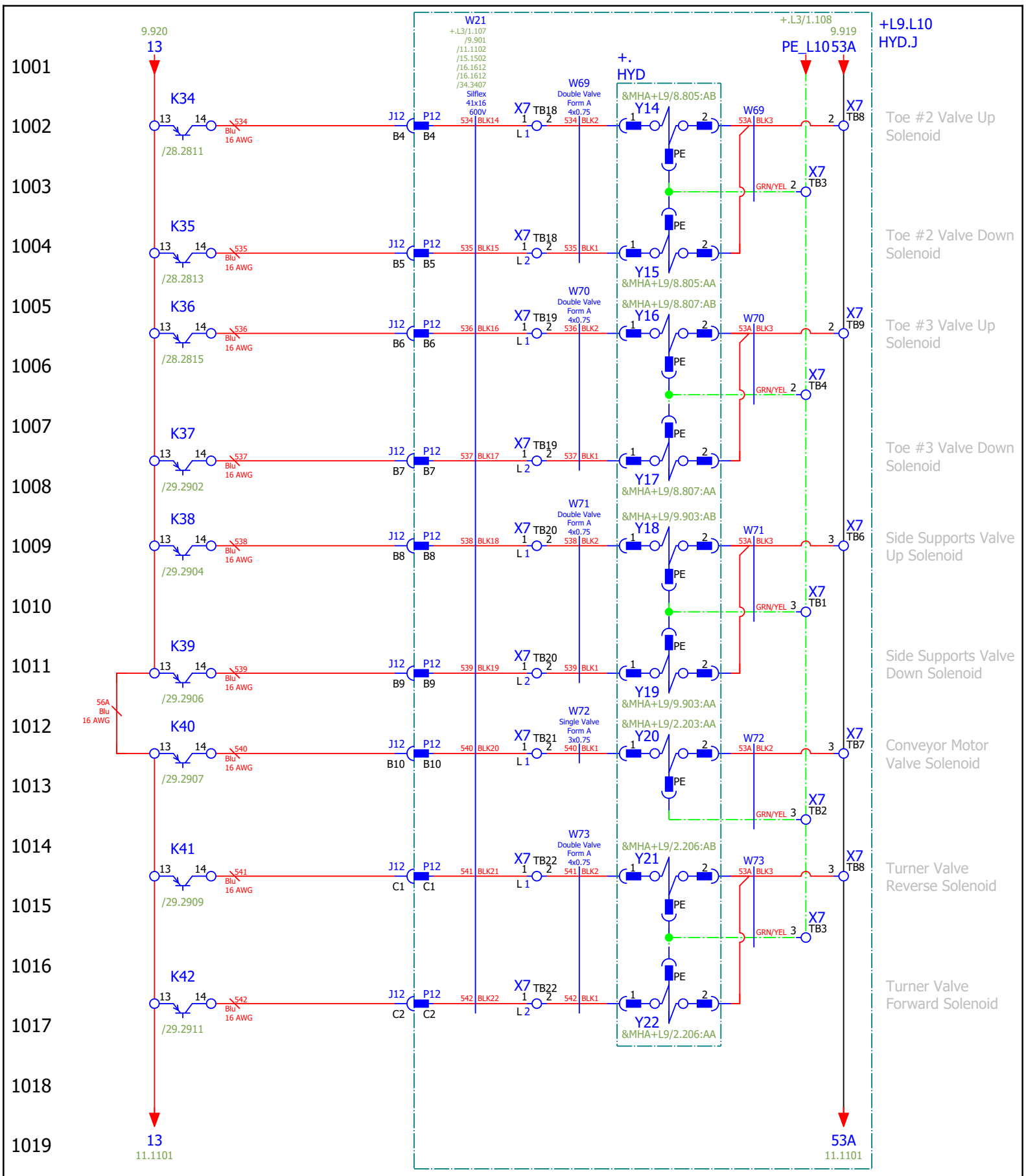

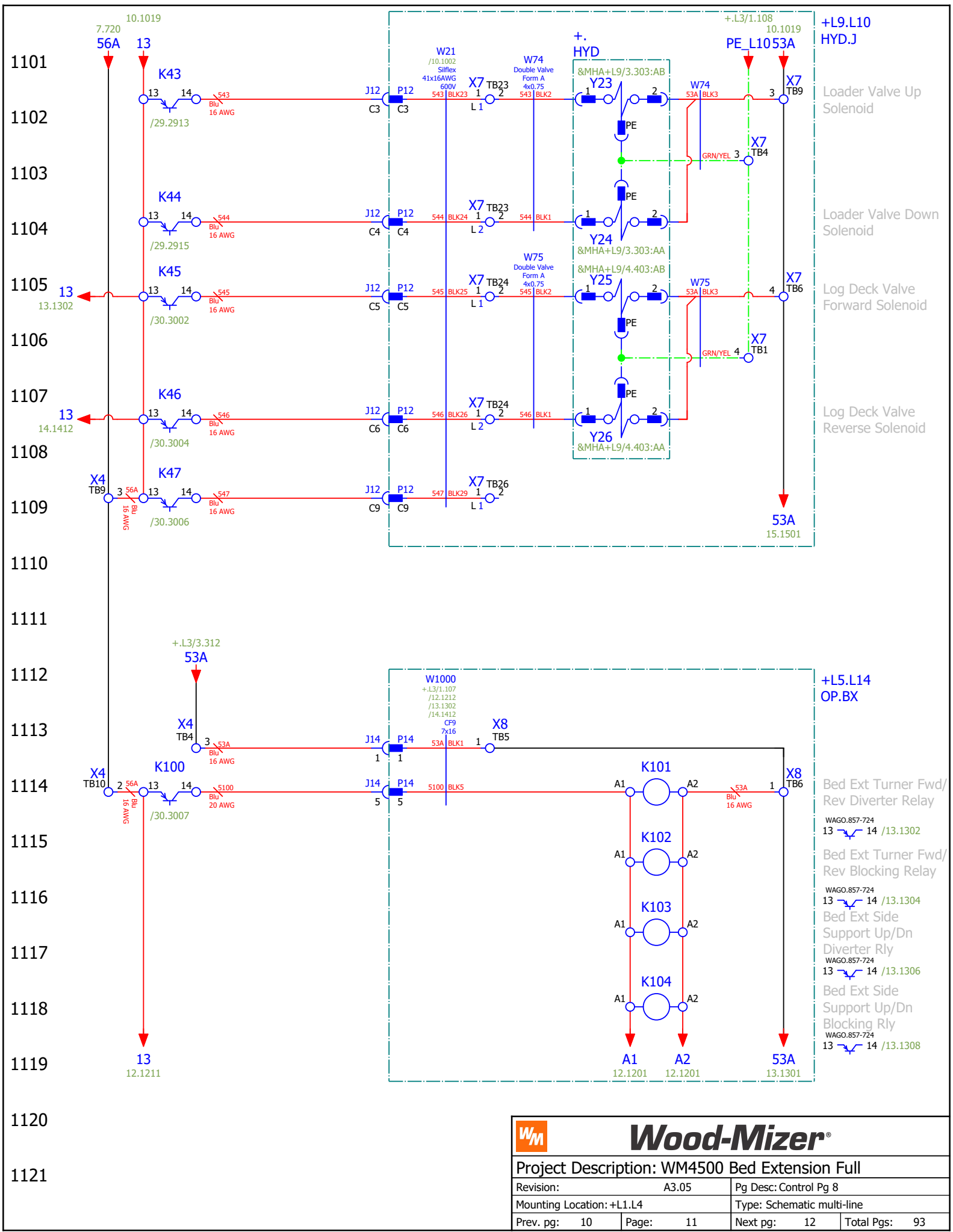

1201
1202
1203
1204
1205
1206
1207
1208
1209
1210
1211
1212
1213
1214
1215
1216
1217
1218
1219
1220
1221

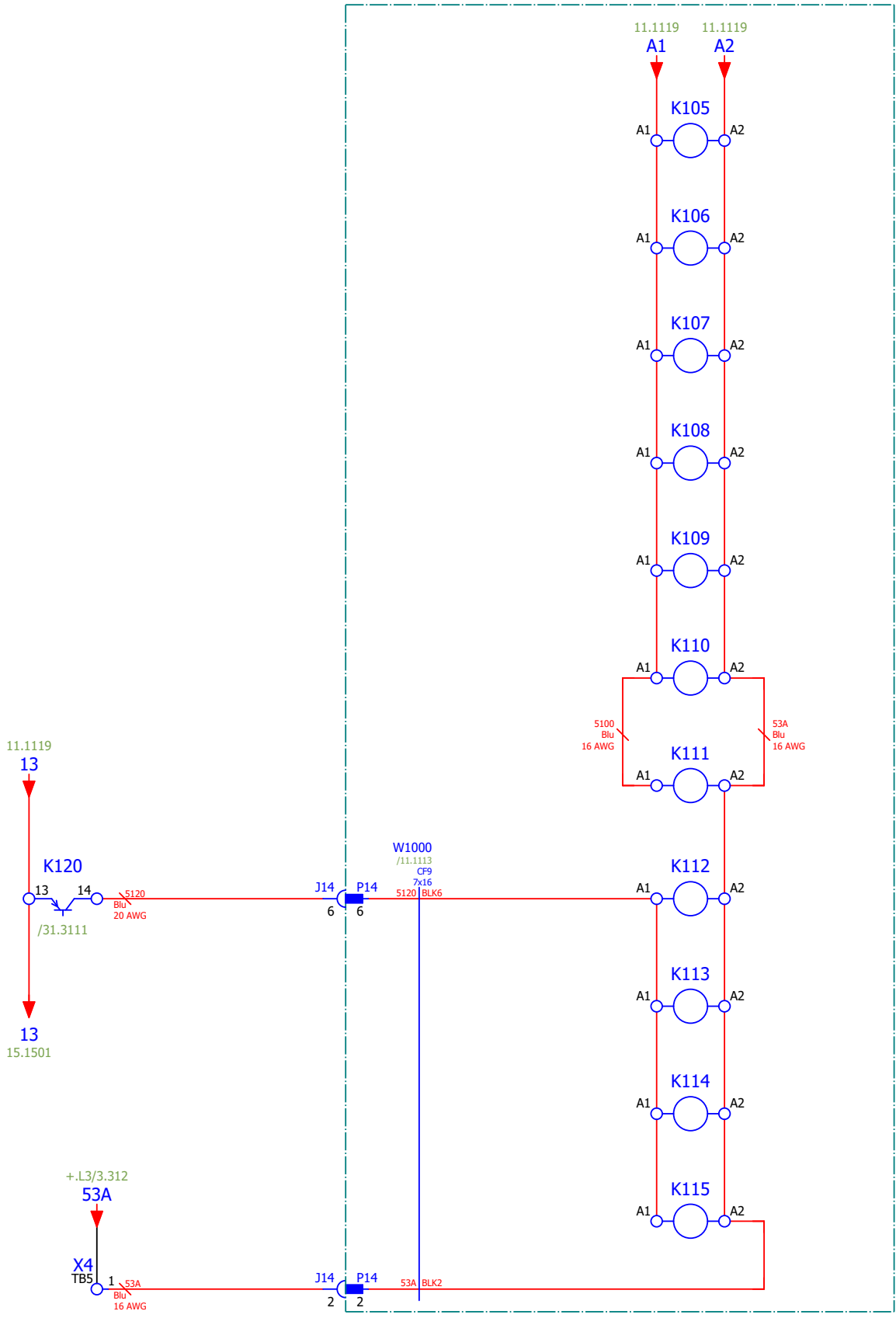

- +L5.L14
OP.BX**
- Bed Ext Turner Up/Dn
Diverter Relay
WAGO.857-724
13 14 /13.1310
- Bed Ext Pwr Taper Fwd/Rev
Diverter Rly
WAGO.857-724
13 14 /13.1312
- Bed Ext Pwr Taper Fwd/Rev
Blocking Rly
WAGO.857-724
13 14 /13.1314
- Bed Ext Loader Up/Dn
Diverter Relay
WAGO.857-724
13 14 /13.1316
- Bed Ext Loader Up/Dn
Blocking Relay
WAGO.857-724
13 14 /13.1318
- Bed Ext Log Deck Fwd/Rev
Diverter Rly
WAGO.857-724
13 14 /14.1402
- Bed Ext Log Deck Fwd/Rev
Blocking Rly
WAGO.857-724
13 14 /14.1404
- Bed Ext Clamp Up
Diverter Solenoid
WAGO.857-724
13 14 /14.1406
- Bed Ext Clamp Down
Diverter Solenoid
WAGO.857-724
13 14 /14.1408
- Bed Ext Clamp In
Diverter Solenoid
WAGO.857-724
13 14 /14.1410
- Bed Ext Clamp Out
Diverter Solenoid
WAGO.857-724
13 14 /14.1412

1301
1302
1303
1304
1305
1306
1307
1308
1309
1310
1311
1312
1313
1314
1315
1316
1317
1318
1319
1320
1321

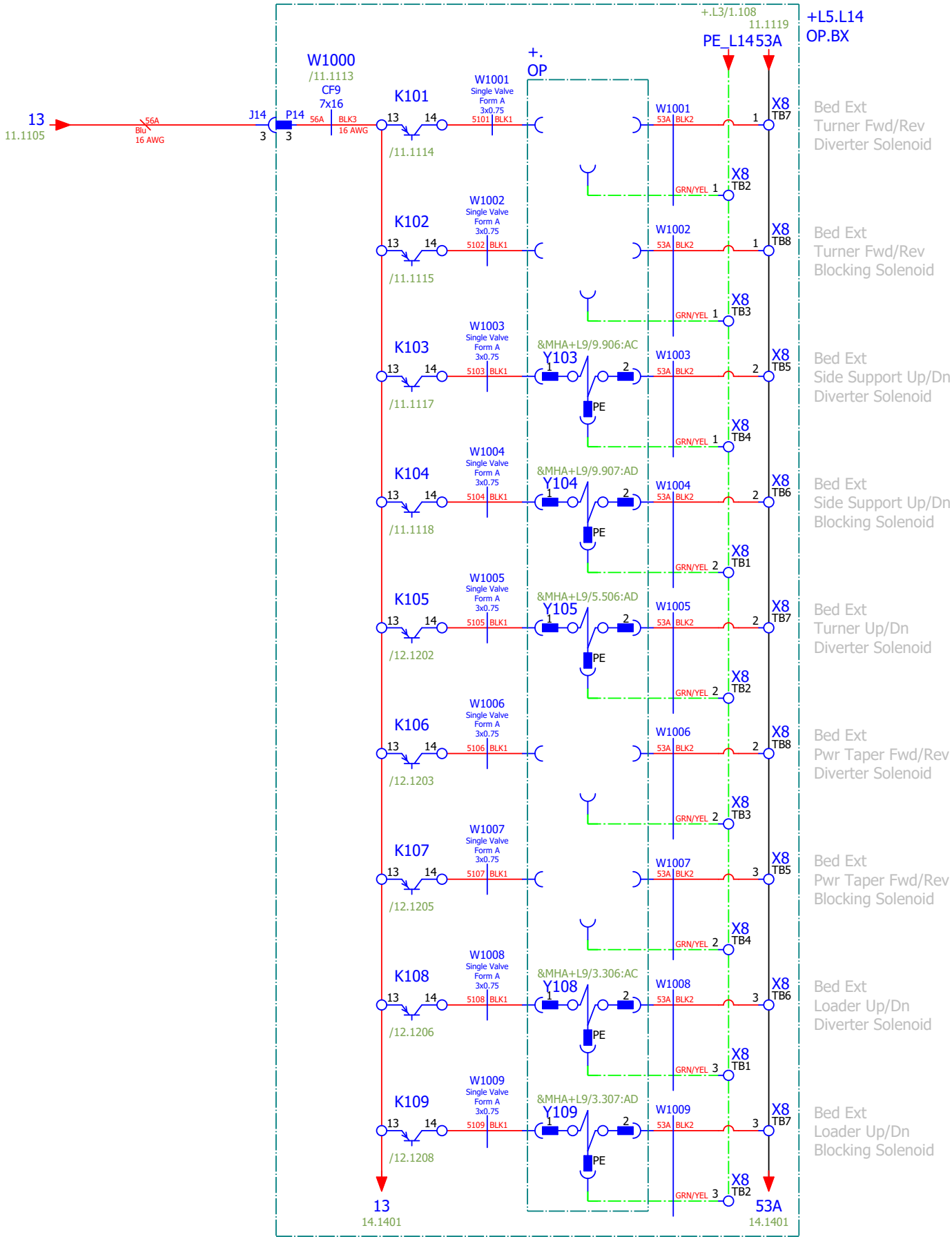

1401
1402
1403
1404
1405
1406
1407
1408
1409
1410
1411
1412
1413
1414
1415
1416
1417
1418
1419
1420
1421

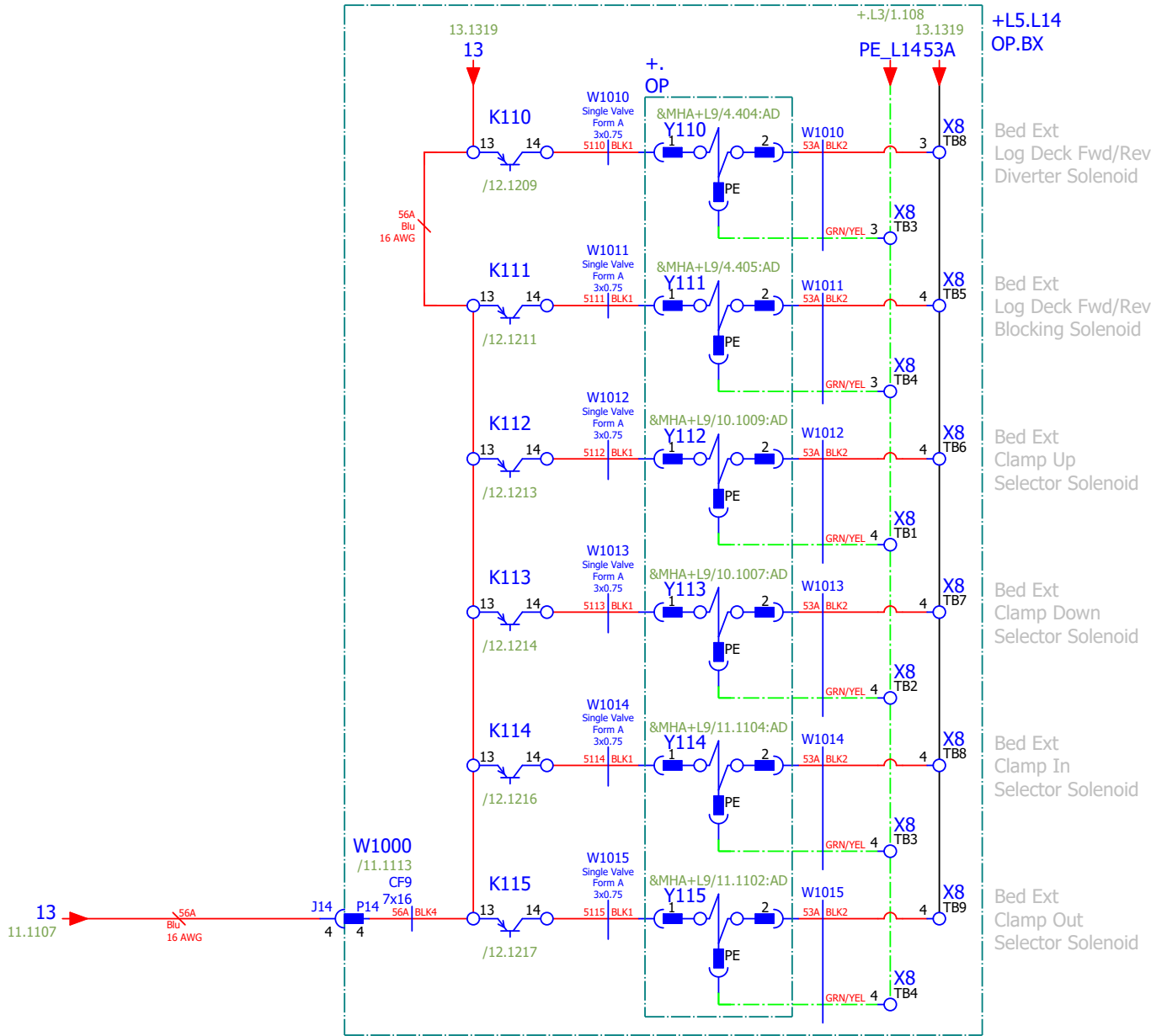

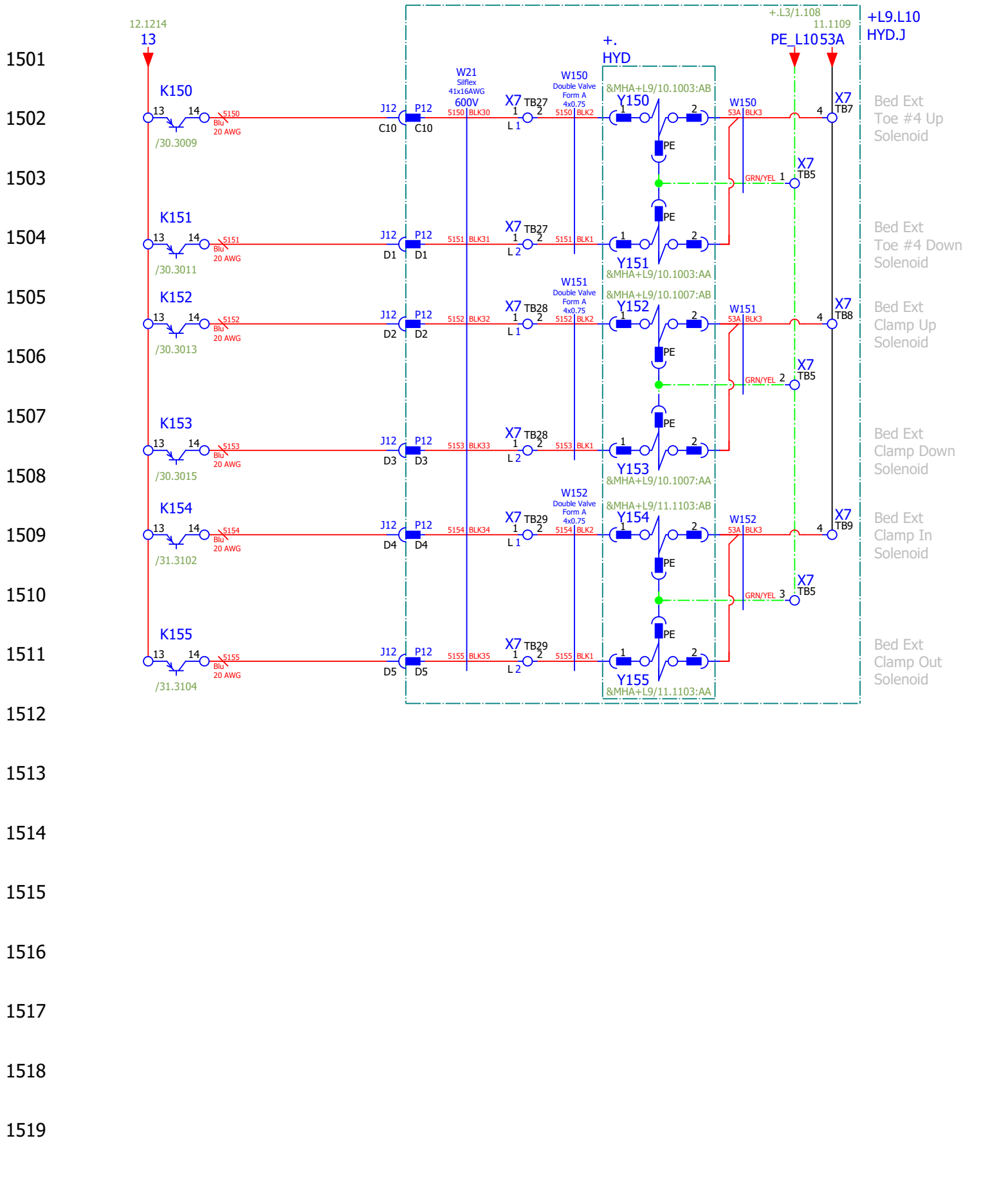

+L9.L10
HYD.J

Bed Ext
Toe #4 Up
Solenoid

Bed Ext
Toe #4 Down
Solenoid

Bed Ext
Clamp Up
Solenoid

Bed Ext
Clamp Down
Solenoid

Bed Ext
Clamp In
Solenoid

Bed Ext
Clamp Out
Solenoid

 Wood-Mizer®	
Project Description: WM4500 Bed Extension Full	
Revision: A3.05	Pg Desc: Control Pg 12
Mounting Location: +L1.L4	
Prev. pg: 14	Type: Schematic multi-line
Page: 15	Next pg: 16
Total Pgs: 93	

1521

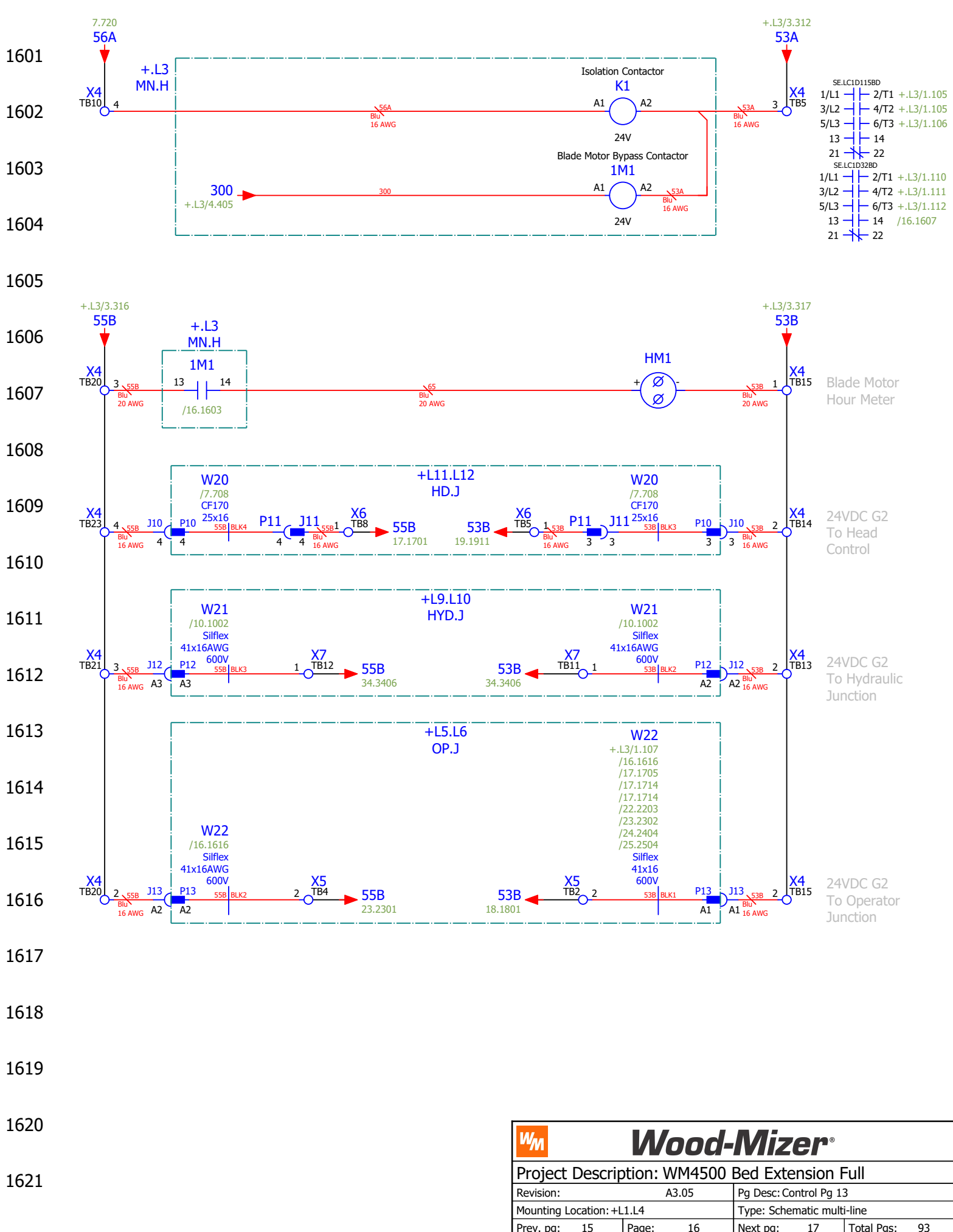

- SE.LCID115BD
- 1/L1 --- 2/T1 +.L3/1.105
 - 3/L2 --- 4/T2 +.L3/1.105
 - 5/L3 --- 6/T3 +.L3/1.106
 - 13 --- 14
 - 21 --- 22
- SE.LCID32BD
- 1/L1 --- 2/T1 +.L3/1.110
 - 3/L2 --- 4/T2 +.L3/1.111
 - 5/L3 --- 6/T3 +.L3/1.112
 - 13 --- 14 /16.1607
 - 21 --- 22

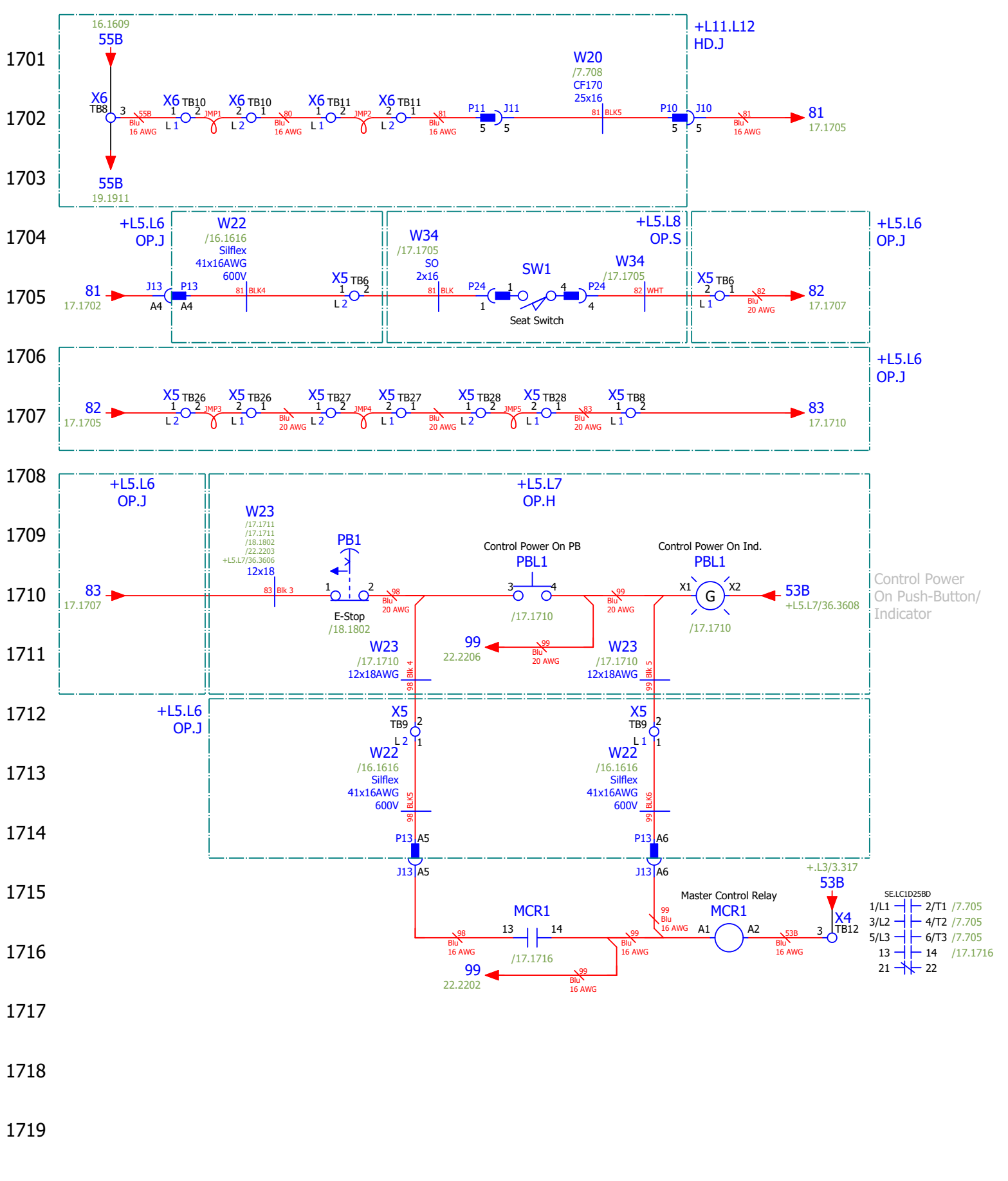

1801
1802
1803
1804
1805
1806
1807
1808
1809
1810
1811
1812
1813
1814
1815
1816
1817
1818
1819
1820
1821

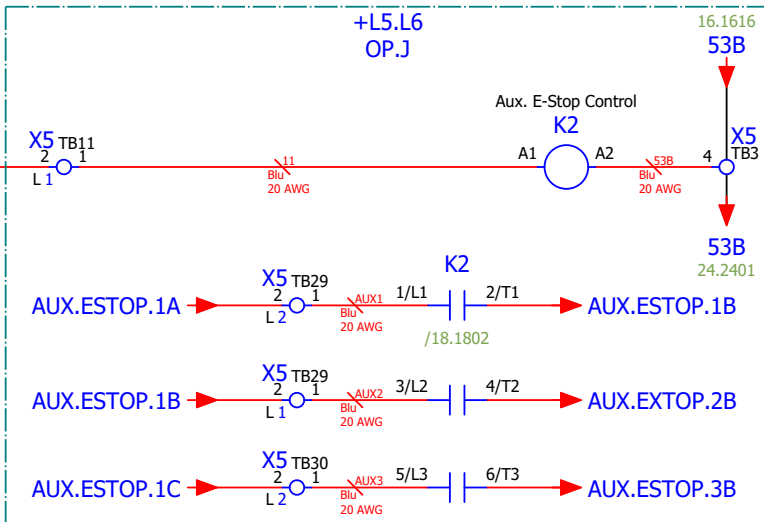
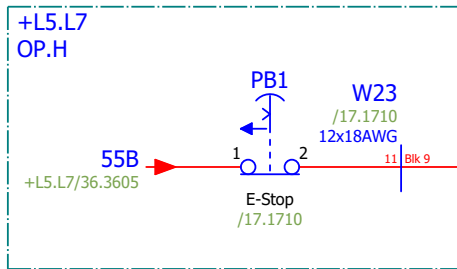

SE.LP1K09108D
1/L1 2/T1 /18.1803
3/L2 4/T2 /18.1805
5/L3 6/T3 /18.1805
13 14

Auxiliary Equipment
E-Stop Control 1

Auxiliary Equipment
E-Stop Control 2

Auxiliary Equipment
E-Stop Control 3

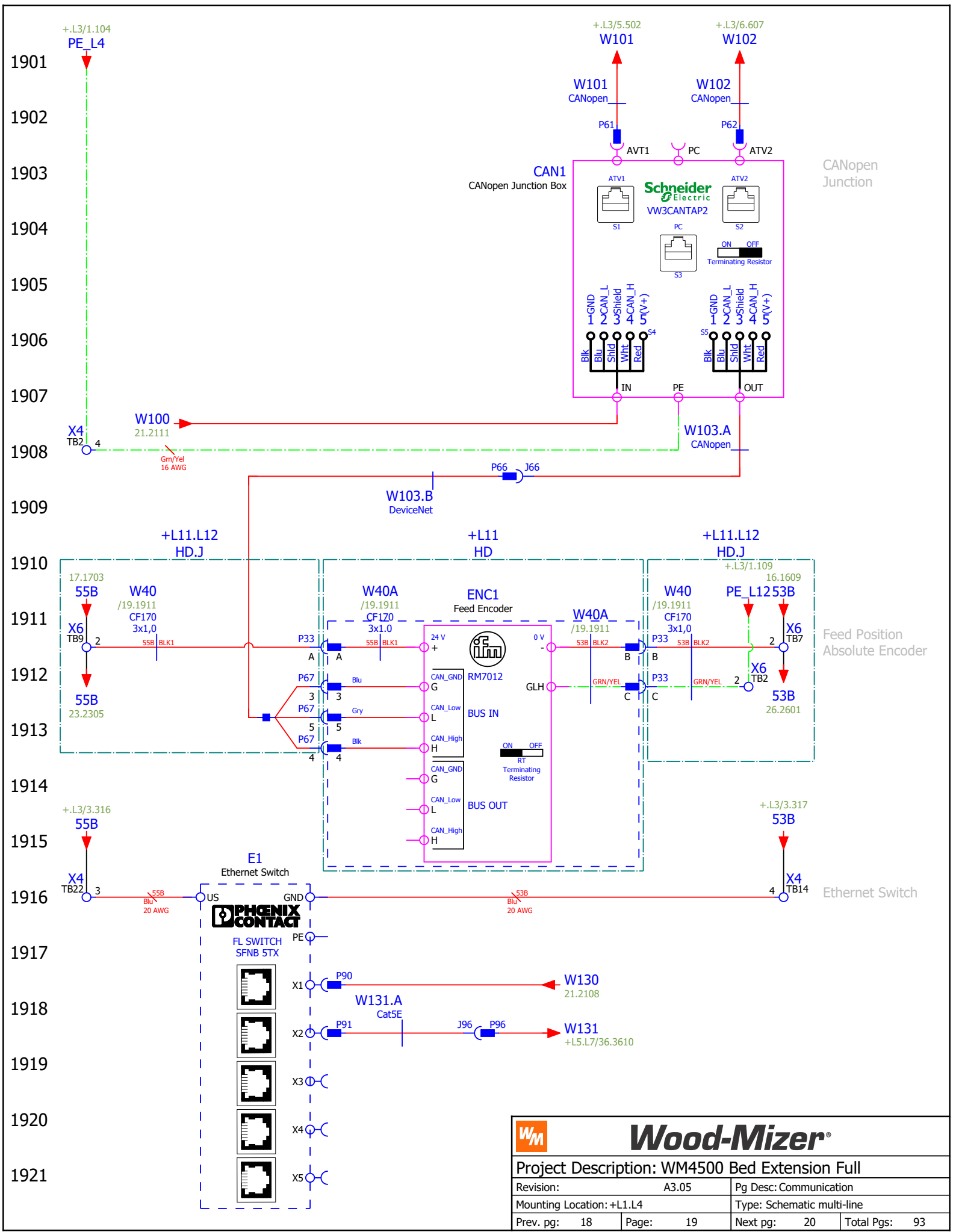

Project Description: WM4500 Bed Extension Full			
Revision:	A3.05	Pg Desc: Communication	
Mounting Location:	+L1.L4	Type: Schematic multi-line	
Prev. pg:	18	Page:	19
		Next pg:	20
		Total Pgs:	93

PLC1.7

PLC1.6

PLC1.5

PLC1.4

PLC1.3

PLC1.2

PLC1.1

PLC1

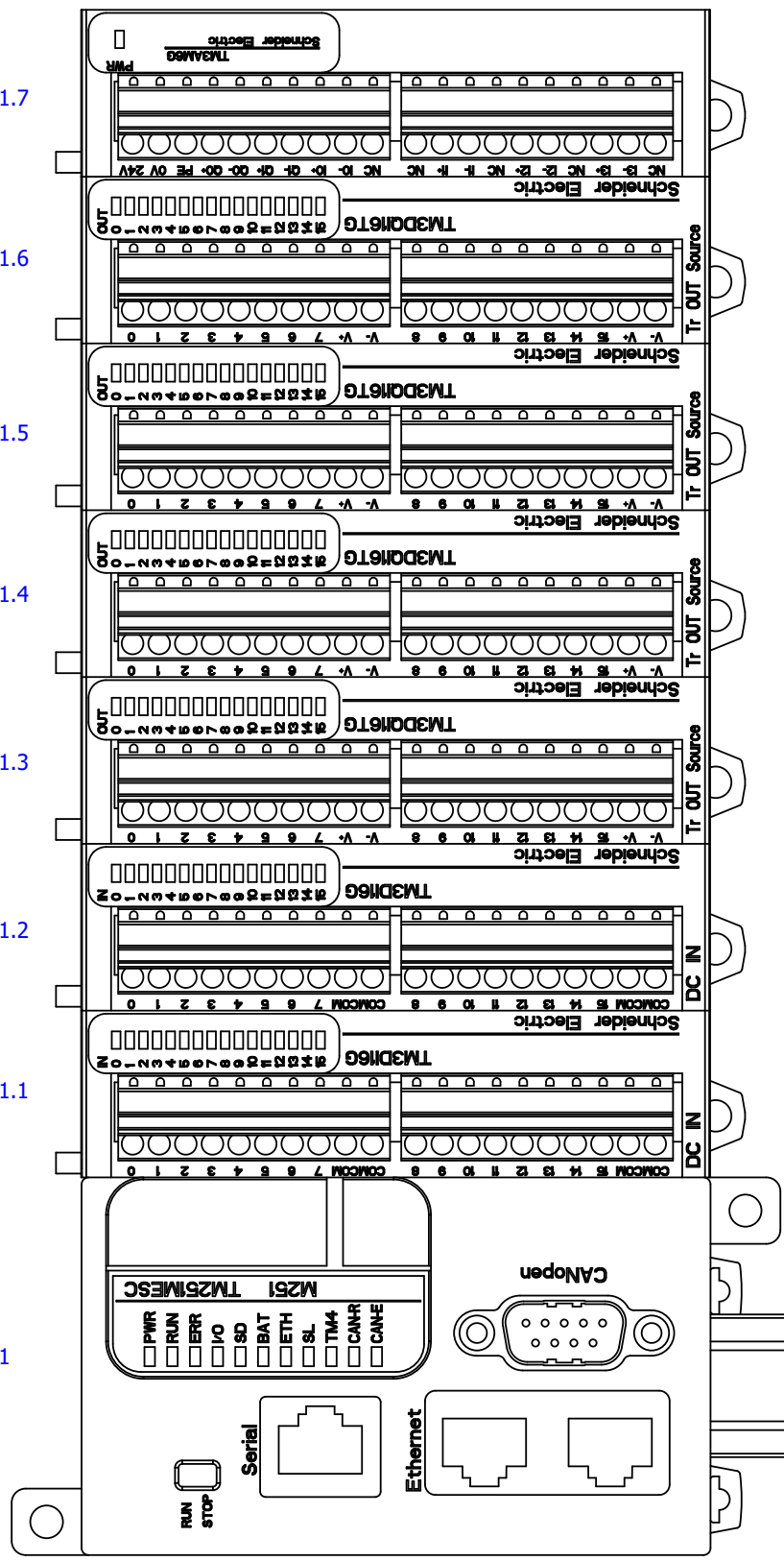

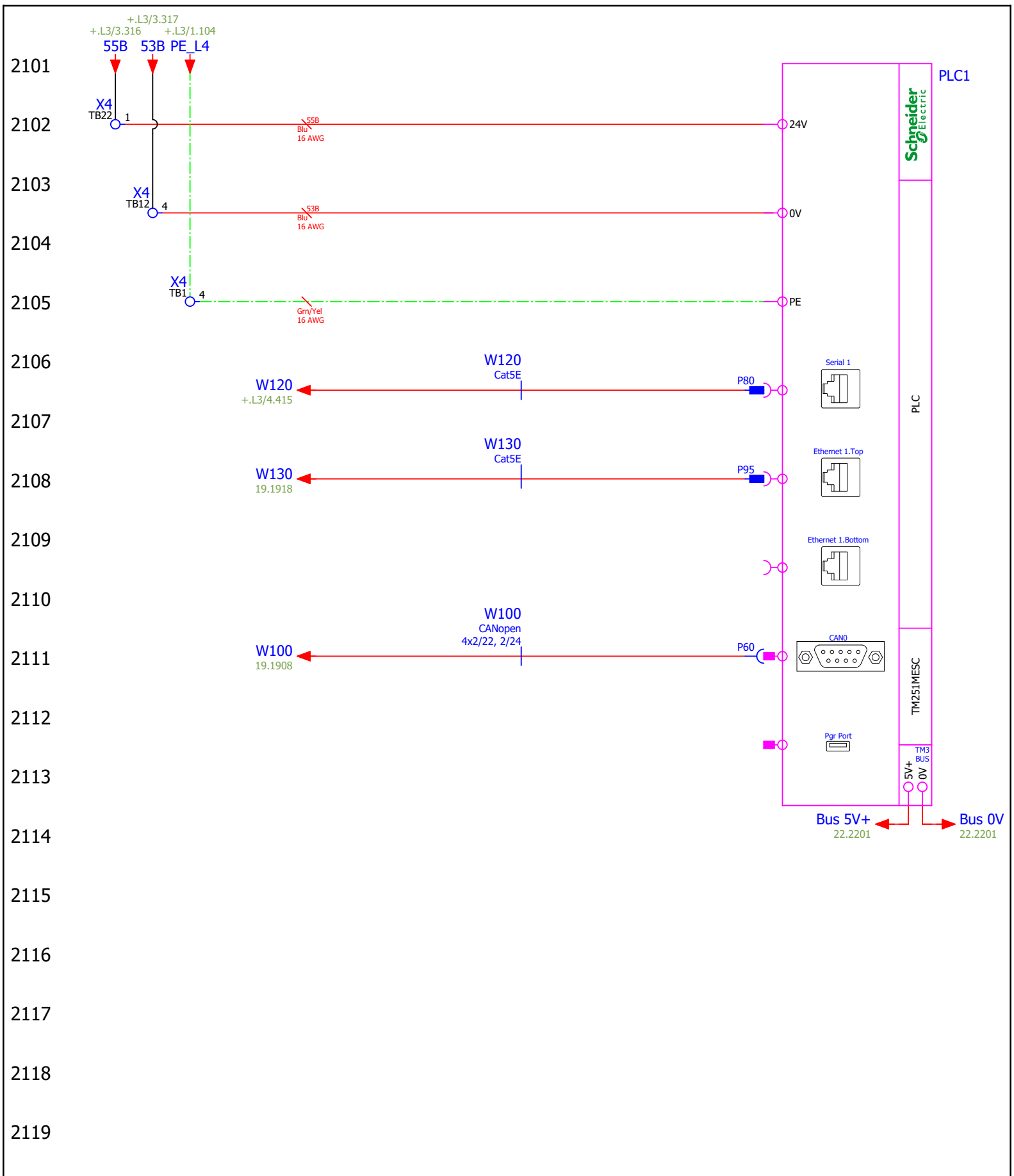

2101

2102

2103

2104

2105

2106

2107

2108

2109

2110

2111

2112

2113

2114

2115

2116

2117

2118

2119

2120

2121

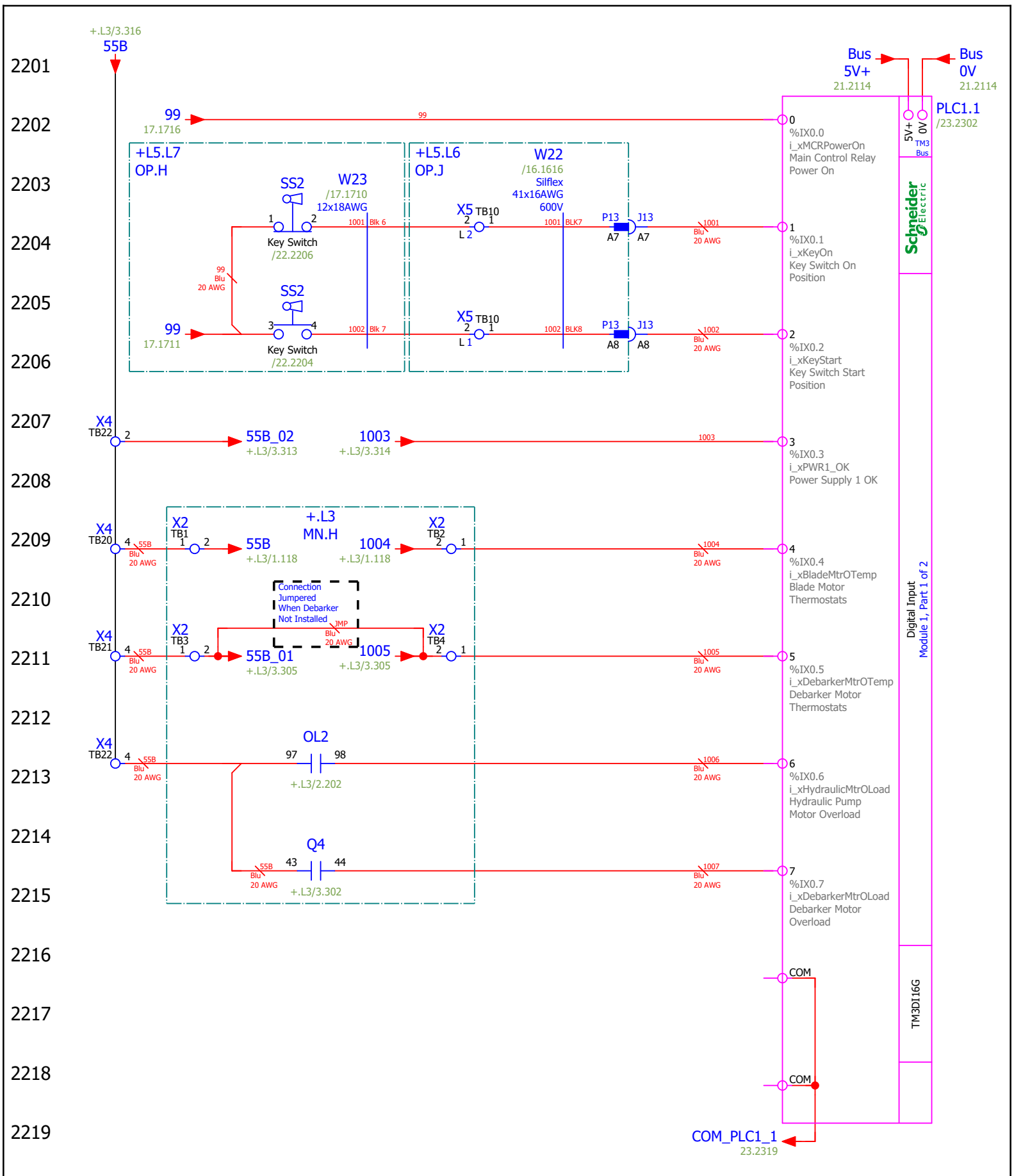

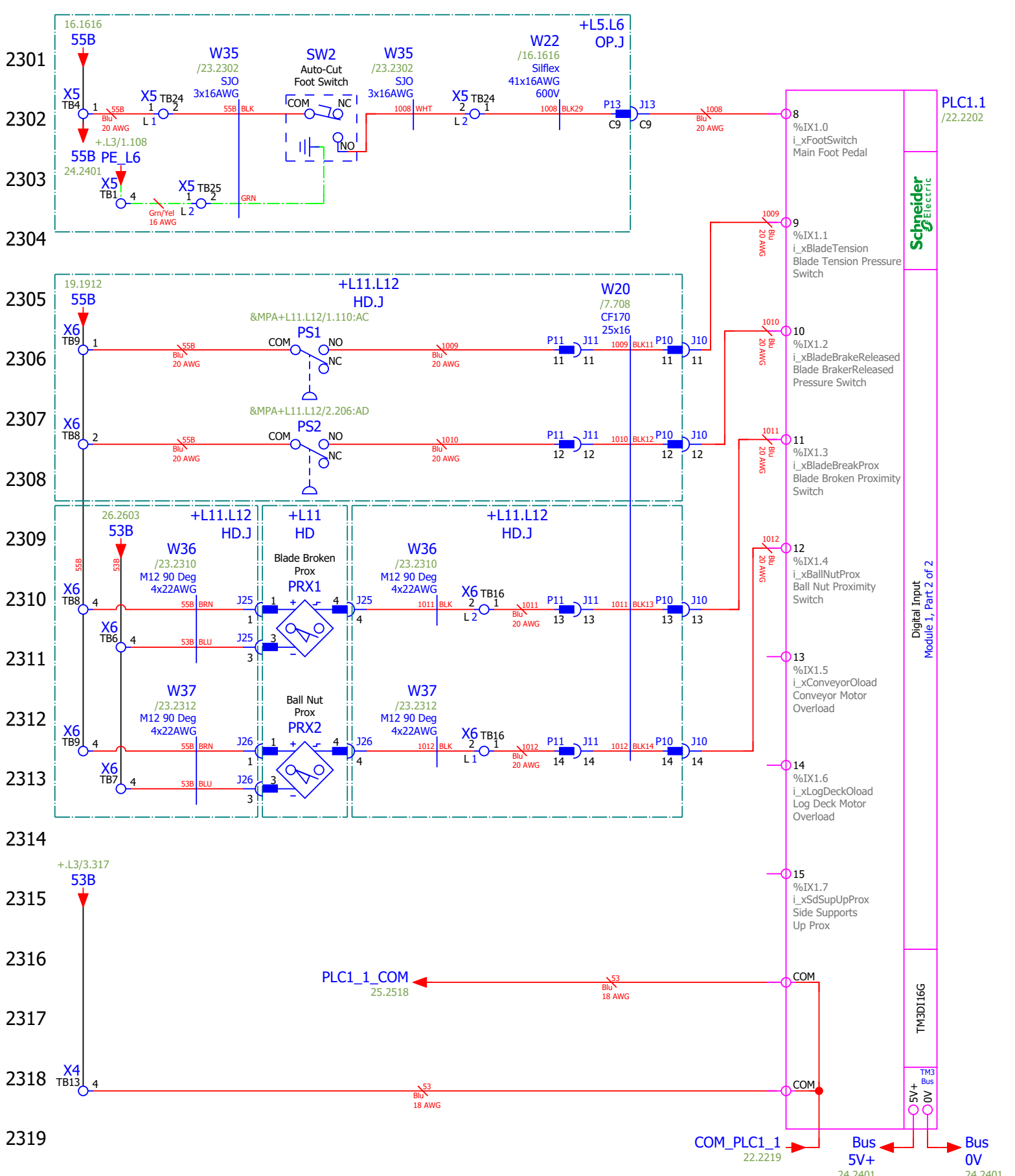

Digital Input Module 1, Part 2 of 2

TM3D116G

TM3 Bus

Project Description: WM4500 Bed Extension Full			
Revision:	A3.05	Pg Desc:	PLC 3
Mounting Location:	+L1.L4	Type:	Schematic multi-line
Prev. pg:	22	Page:	23
		Next pg:	24
		Total Pgs:	93

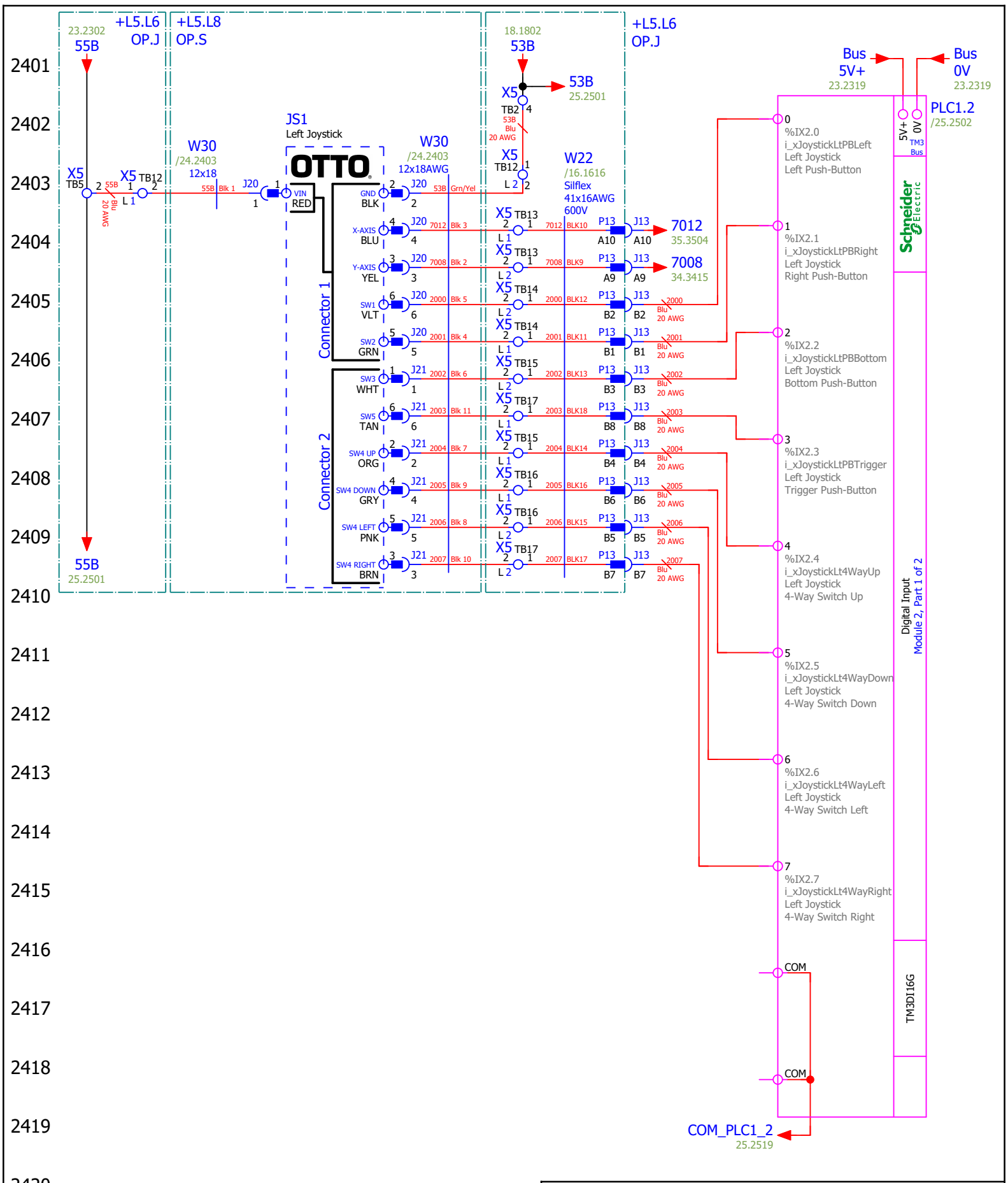

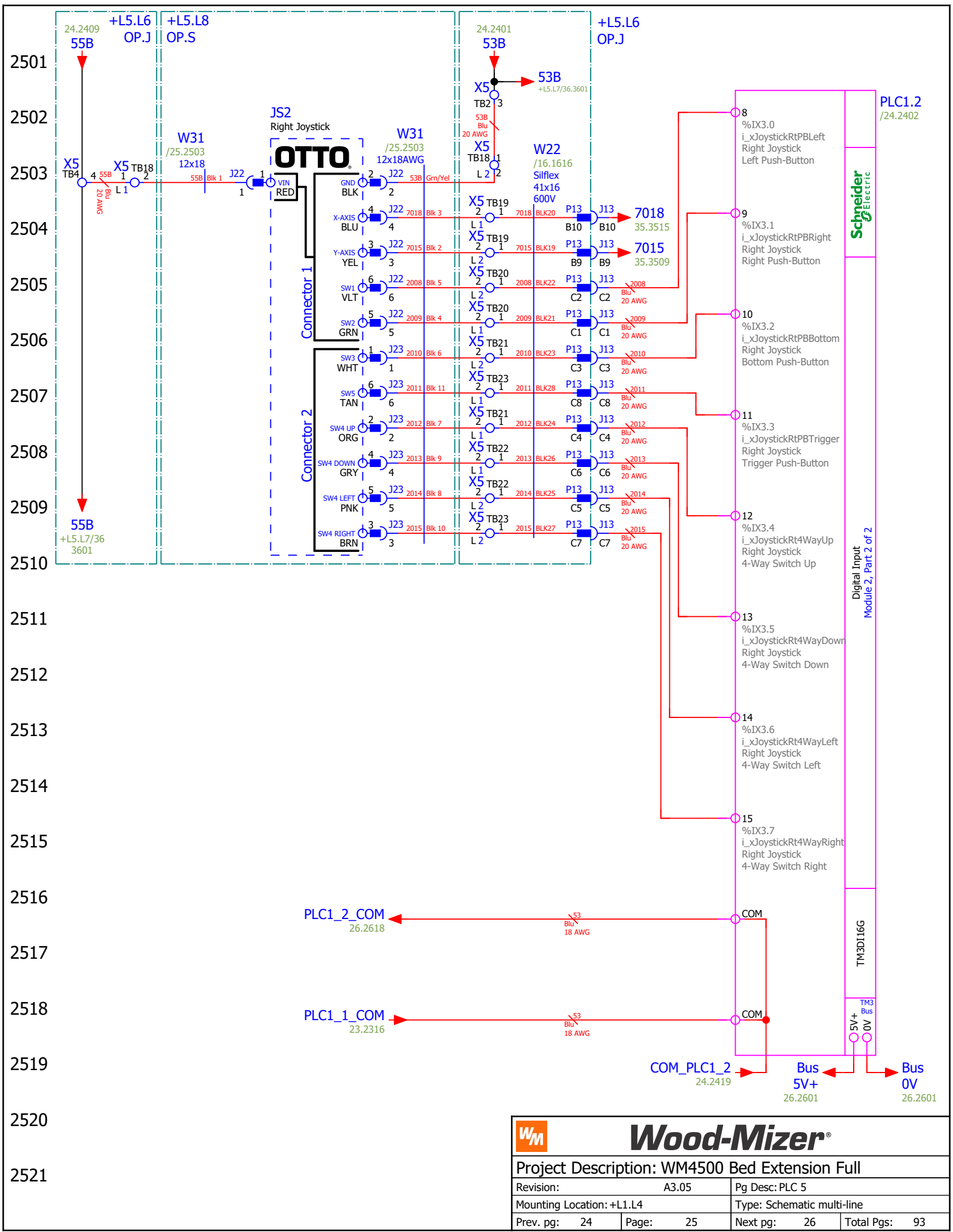

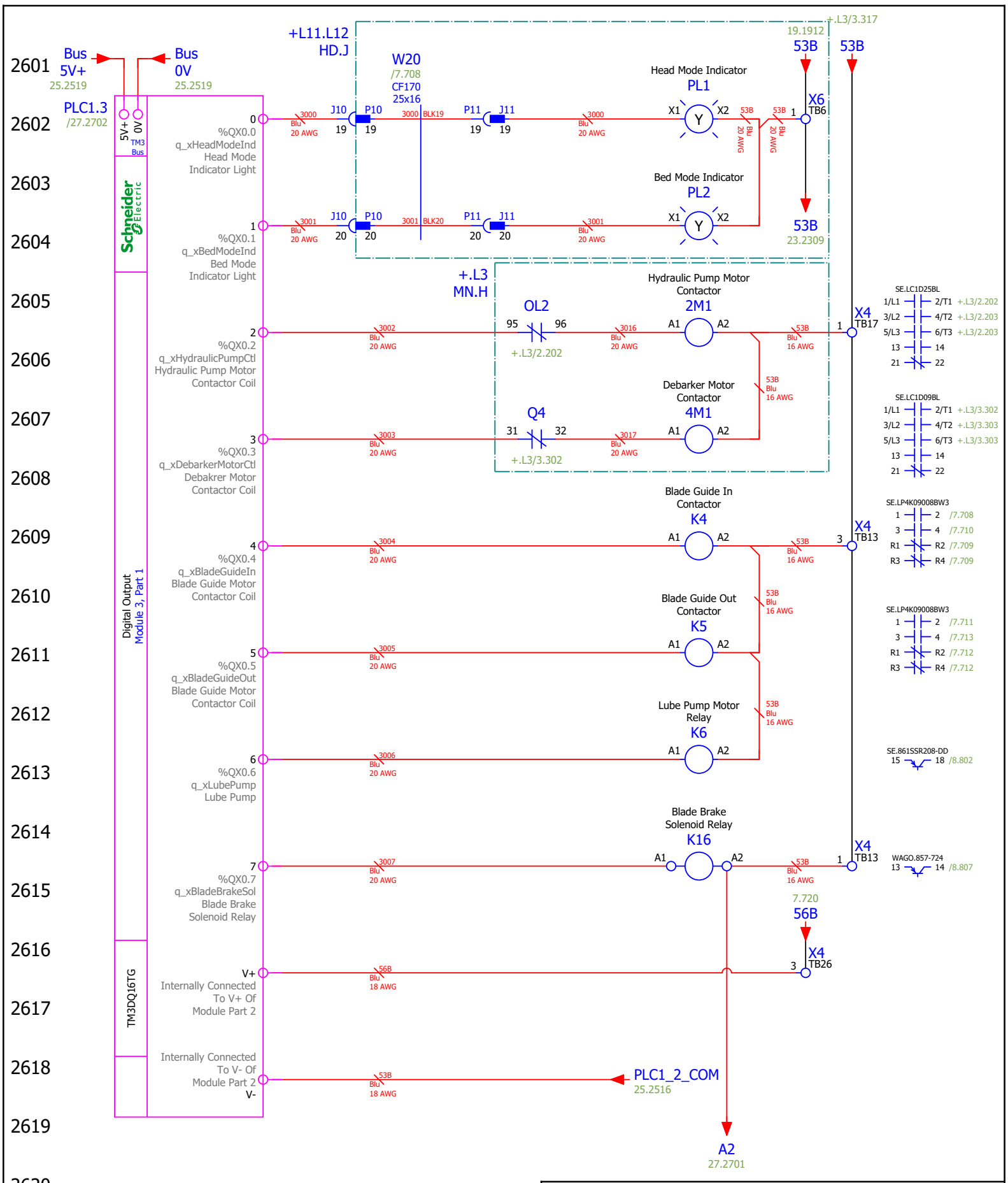

2701
2702
2703
2704
2705
2706
2707
2708
2709
2710
2711
2712
2713
2714
2715
2716
2717
2718
2719
2720
2721

PLC1.3
/26.2602

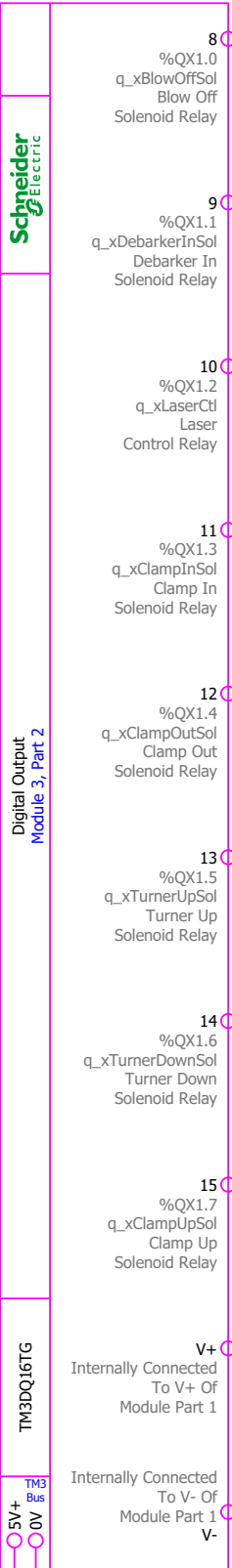

Digital Output
Module 3, Part 2

TM3DQ16TG

5V+
0V

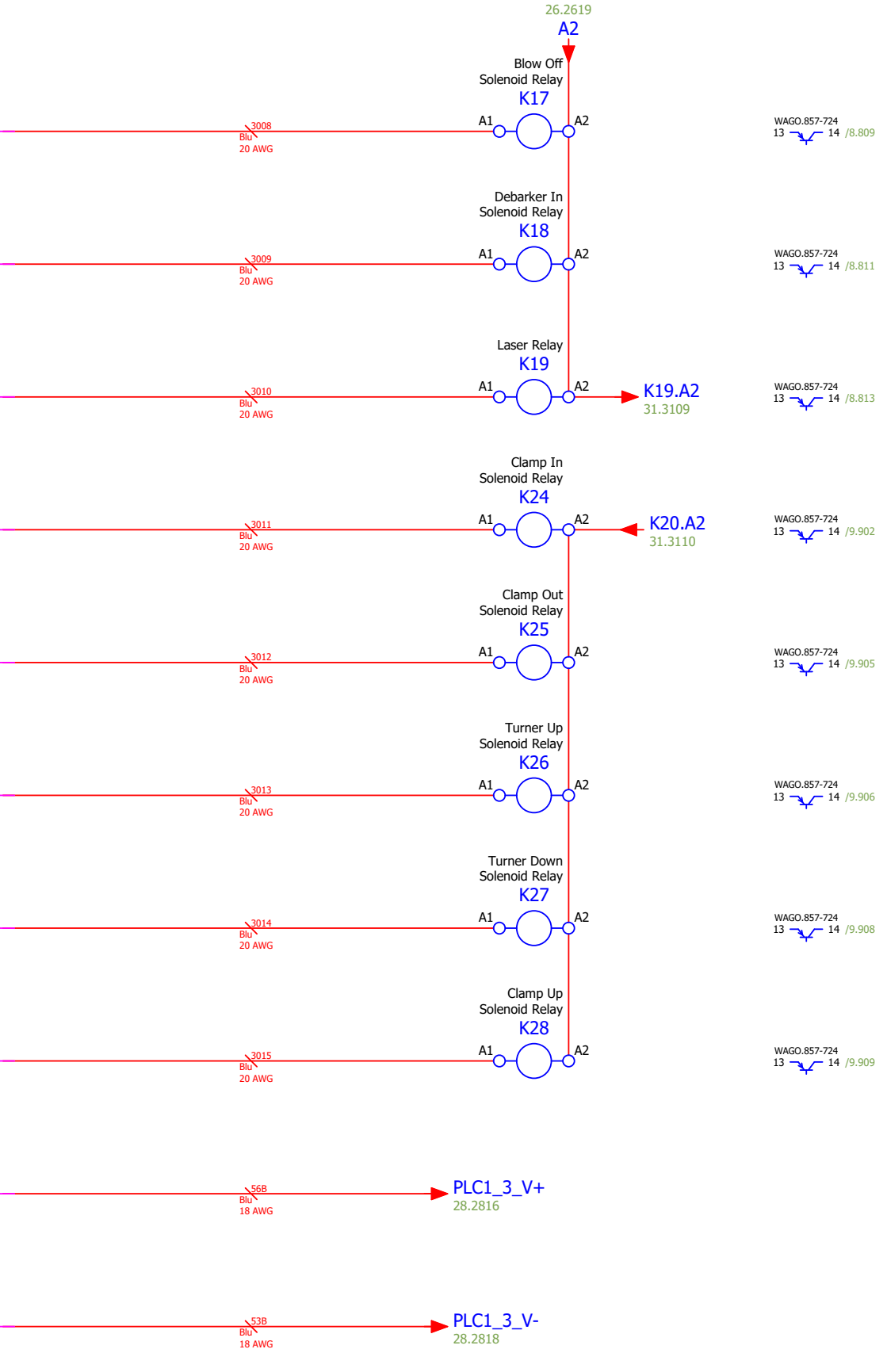
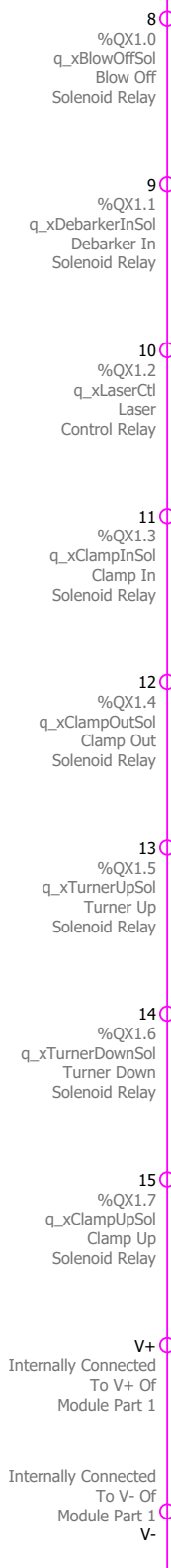

WAGO.857-724
13 14 /8.809

WAGO.857-724
13 14 /8.811

WAGO.857-724
13 14 /8.813

WAGO.857-724
13 14 /9.902

WAGO.857-724
13 14 /9.905

WAGO.857-724
13 14 /9.906

WAGO.857-724
13 14 /9.908

WAGO.857-724
13 14 /9.909

Wood-Mizer®	
Project Description: WM4500 Bed Extension Full	
Revision: A3.05	Pg Desc: PLC 7
Mounting Location: +L1.L4	Type: Schematic multi-line
Prev. pg: 26	Page: 27
Next pg: 28	Total Pgs: 93

2901
2902
2903
2904
2905
2906
2907
2908
2909
2910
2911
2912
2913
2914
2915
2916
2917
2918
2919
2920
2921

PLC1.4
/28.2802

Schneider
Electric

Digital Output
Module 4, Part 2

TM3DQ16TG

5V+
0V

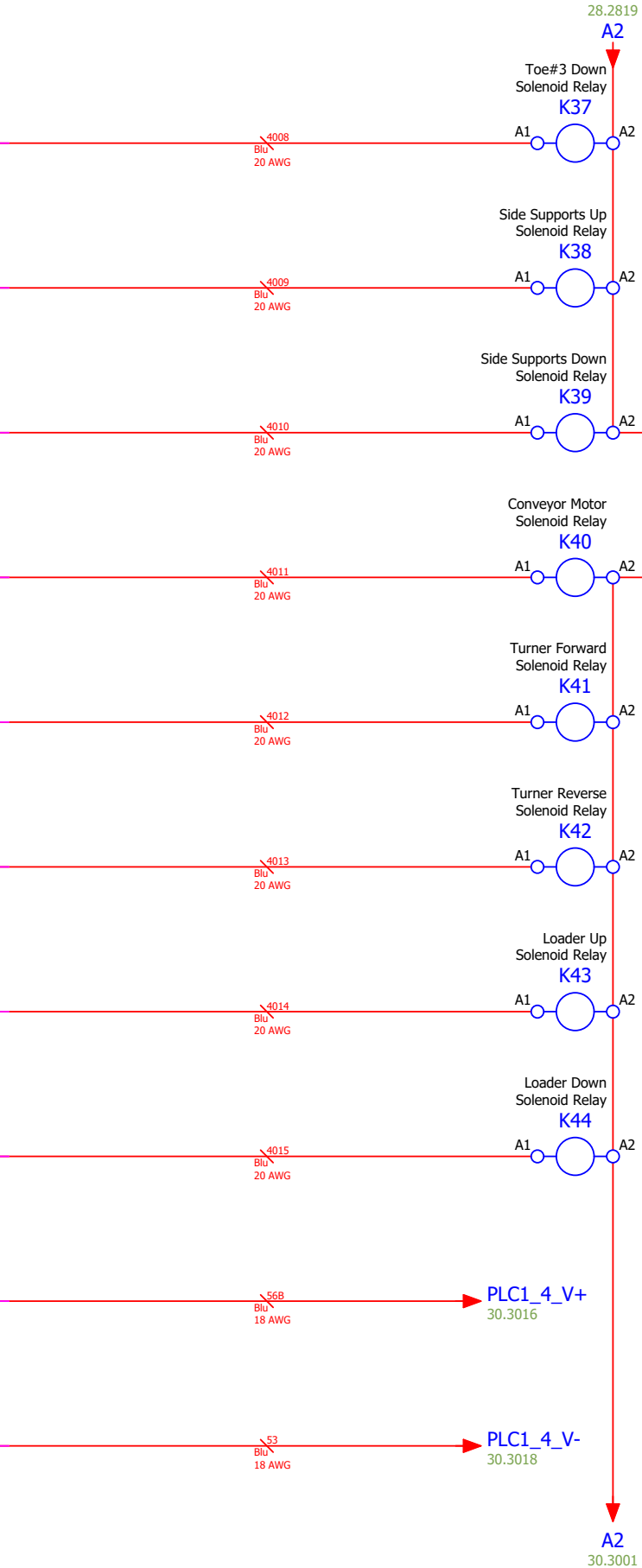
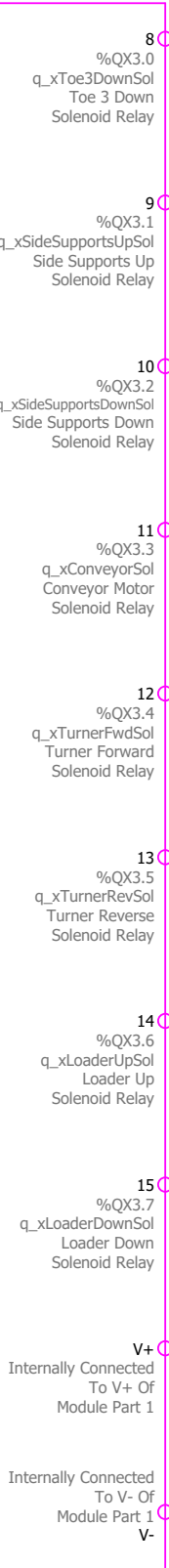

WAGO.857-724
13 14 /10.1008

WAGO.857-724
13 14 /10.1009

WAGO.857-724
13 14 /10.1011

WAGO.857-724
13 14 /10.1012

WAGO.857-724
13 14 /10.1015

WAGO.857-724
13 14 /10.1017

WAGO.857-724
13 14 /11.1102

WAGO.857-724
13 14 /11.1104

Project Description: WM4500 Bed Extension Full			
Revision:	A3.05	Pg Desc: PLC 9	
Mounting Location:	+L1.L4	Type: Schematic multi-line	
Prev. pg:	28	Page:	29
		Next pg:	30
		Total Pgs:	93

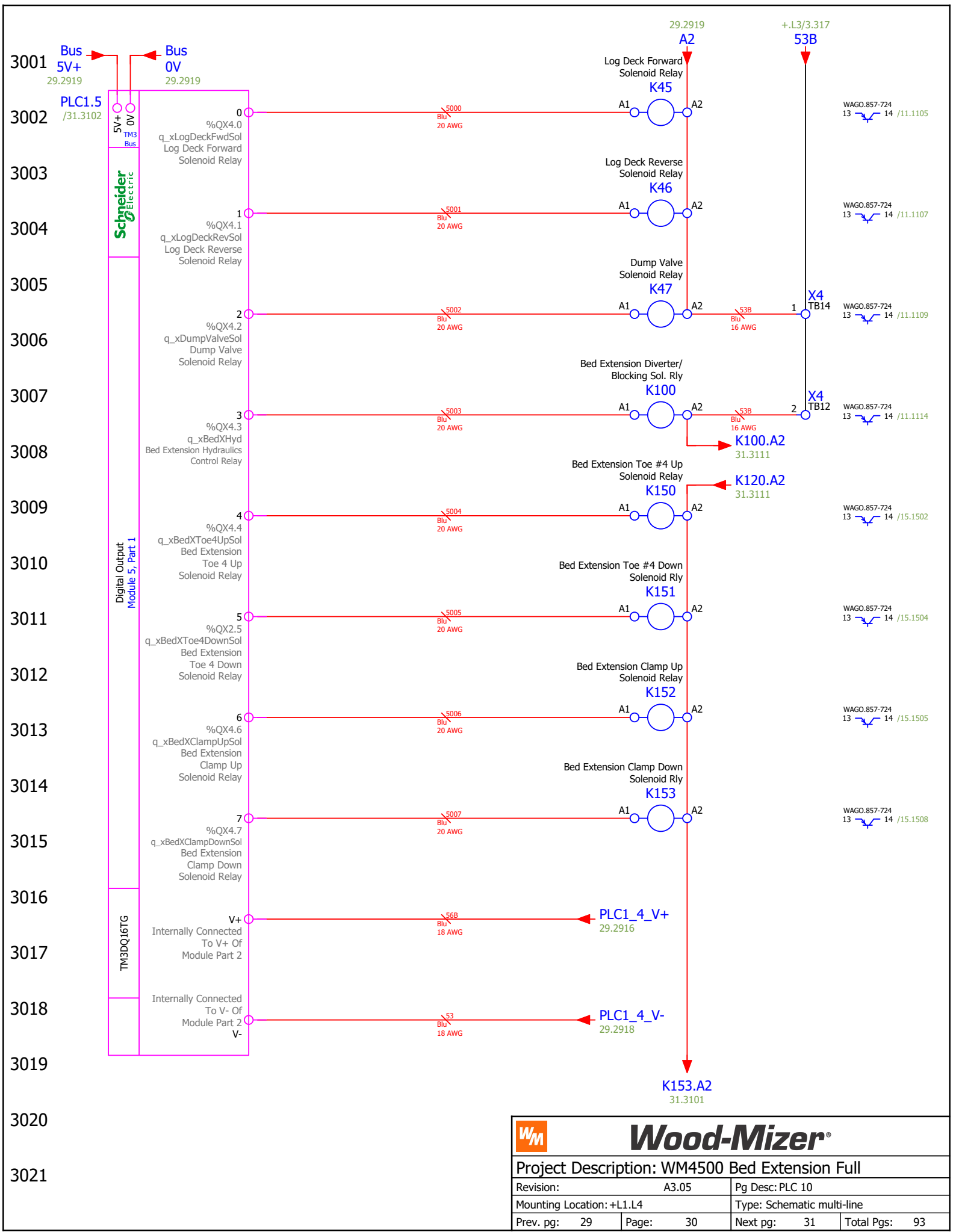

 Wood-Mizer®			
Project Description: WM4500 Bed Extension Full			
Revision:	A3.05	Pg Desc: PLC 10	
Mounting Location:	+L1.L4	Type: Schematic multi-line	
Prev. pg:	29	Page:	30
		Next pg:	31
		Total Pgs:	93

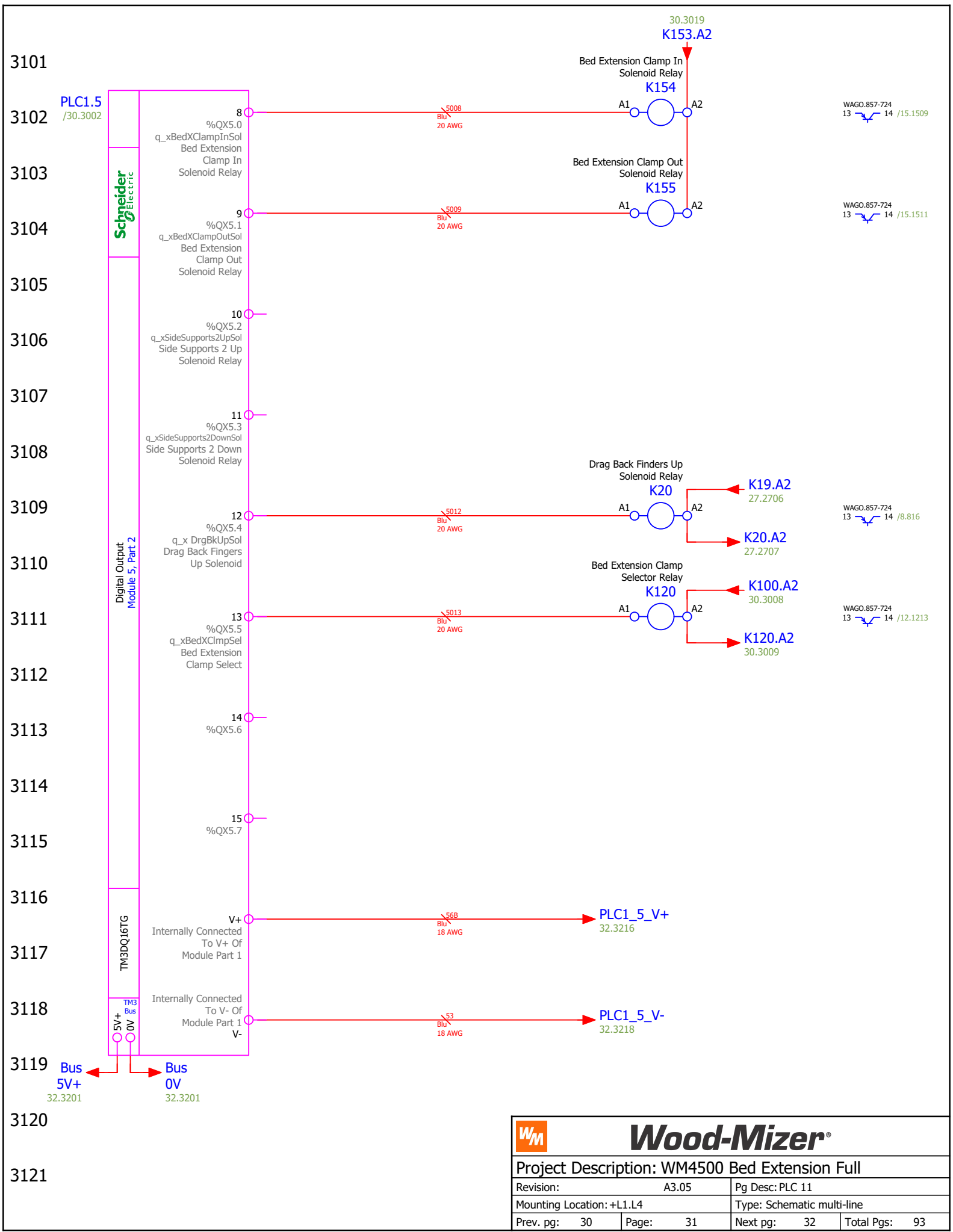

3201 Bus 5V+ 31.3119 Bus 0V 31.3119

3202 PLC1.6 /33.3302

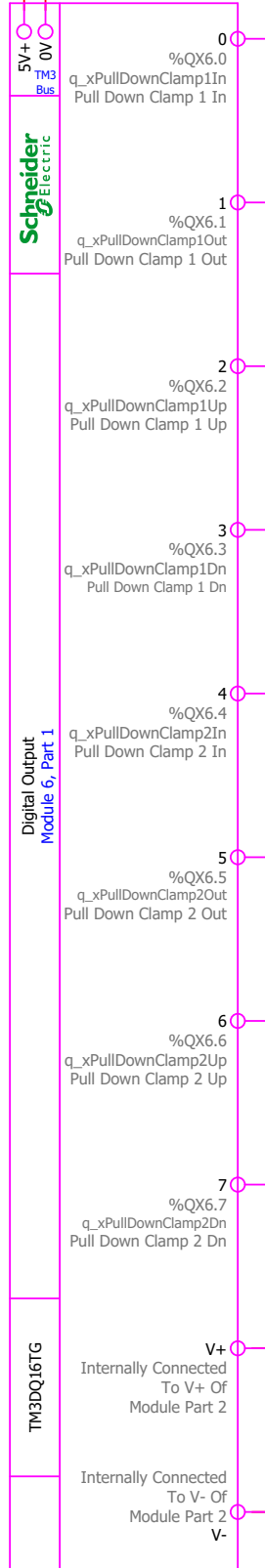

3203

3204

3205

3206

3207

3208

3209

3210

3211

3212

3213

3214

3215

3216

3217

3218

3219

3220

3221

568
Blu
18 AWG

PLC1_5_V+ 31.3116

53
Blu
18 AWG

PLC1_5_V- 31.3118

		Wood-Mizer®	
Project Description: WM4500 Bed Extension Full			
Revision:	A3.05	Pg Desc: PLC 12	
Mounting Location: +L1.L4		Type: Schematic multi-line	
Prev. pg:	31	Page:	32
Next pg:		33	Total Pgs: 93

3301

3302 PLC1.6
/32.3202

3303

3304

3305

3306

3307

3308

3309

3310

3311

3312

3313

3314

3315

3316

3317

3318

3319

3320

3321

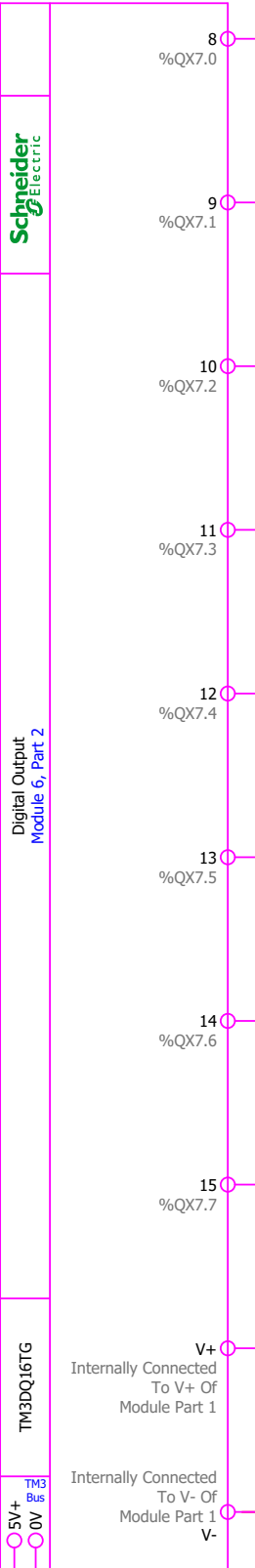

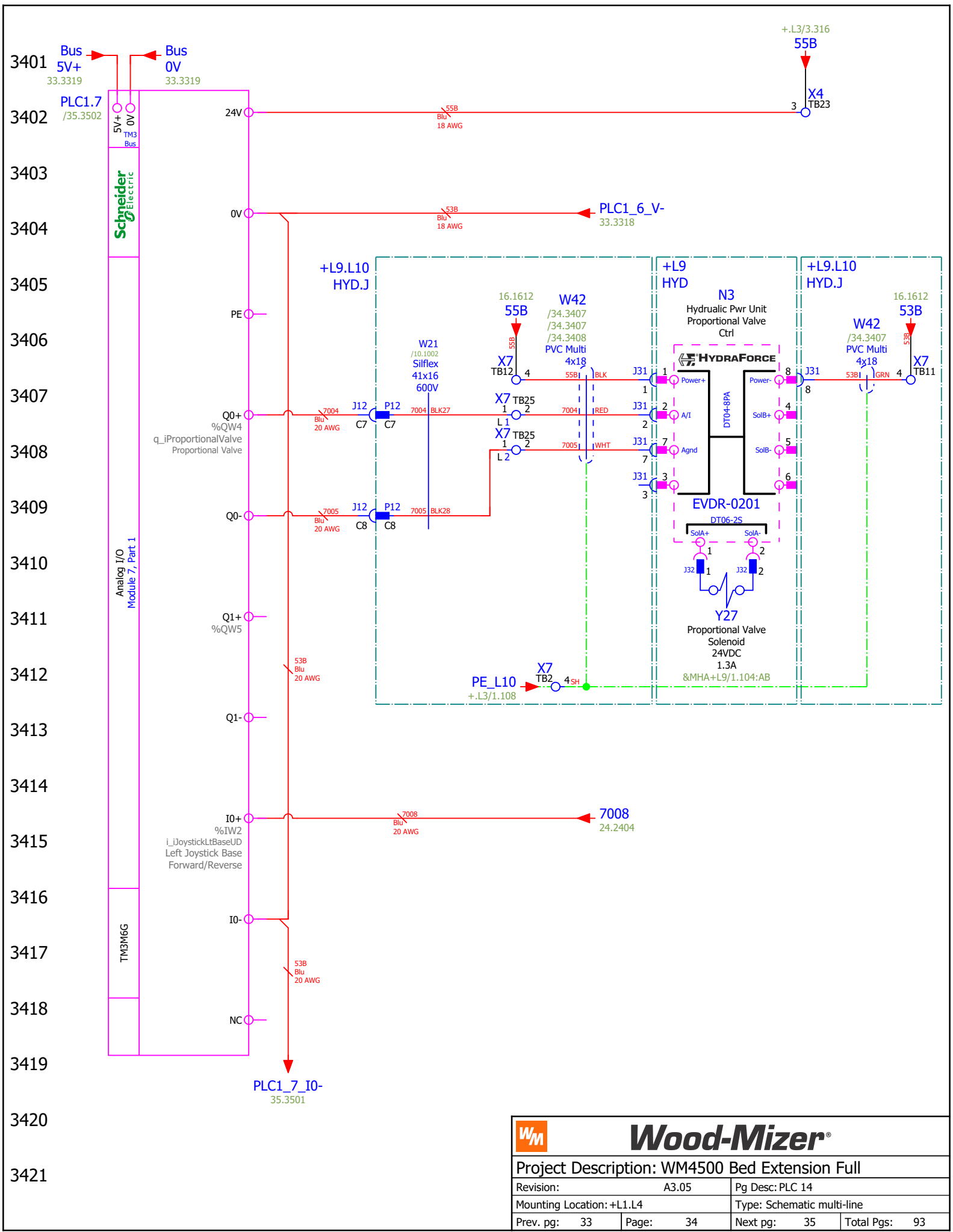

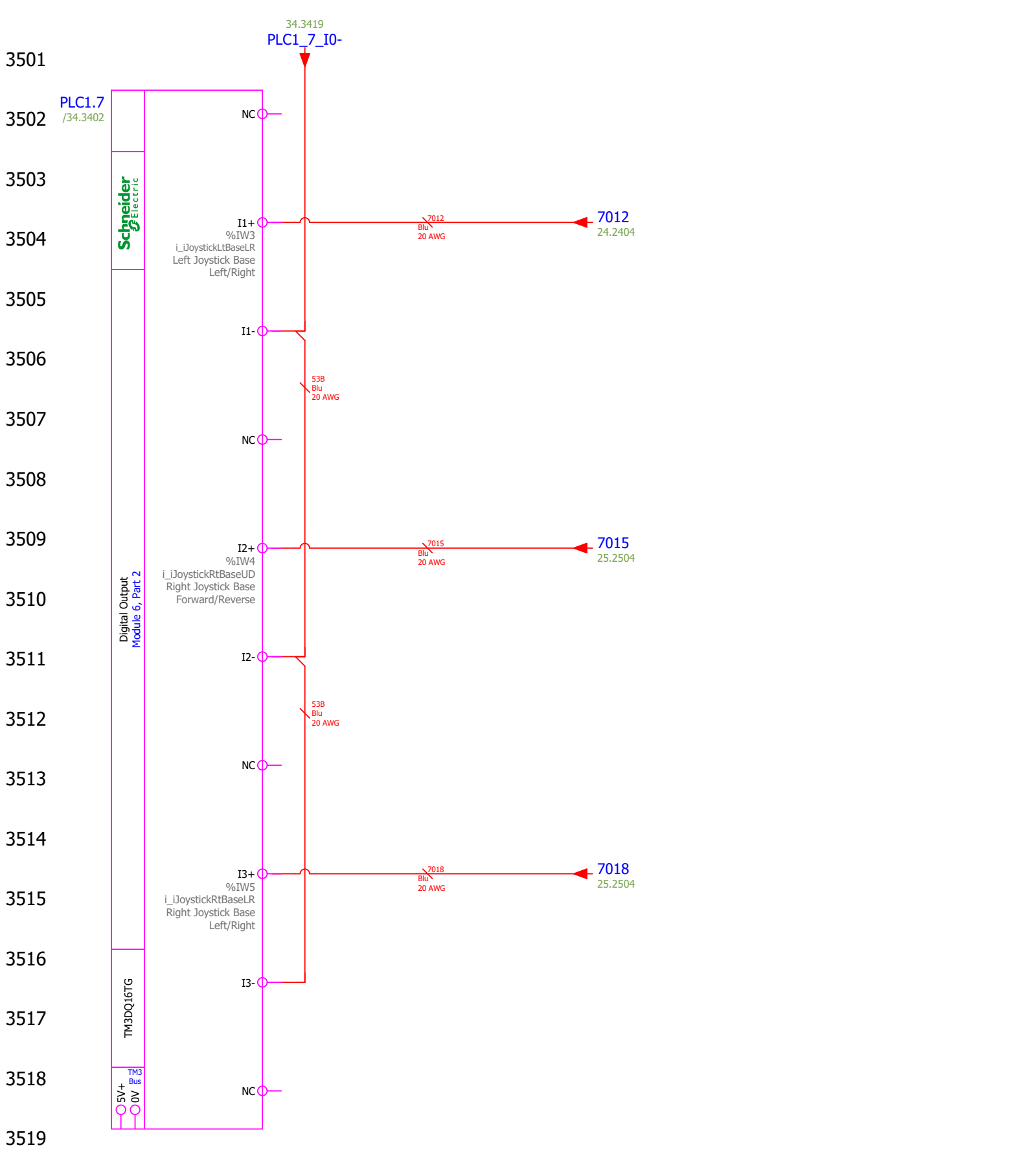

 Wood-Mizer®		
Project Description: WM4500 Bed Extension Full		
Revision:	A3.05	Pg Desc: PLC 15
Mounting Location: +L1.L4		Type: Schematic multi-line
Prev. pg:	34	Page: 35
Next pg: +L5.L7/36		Total Pgs: 93

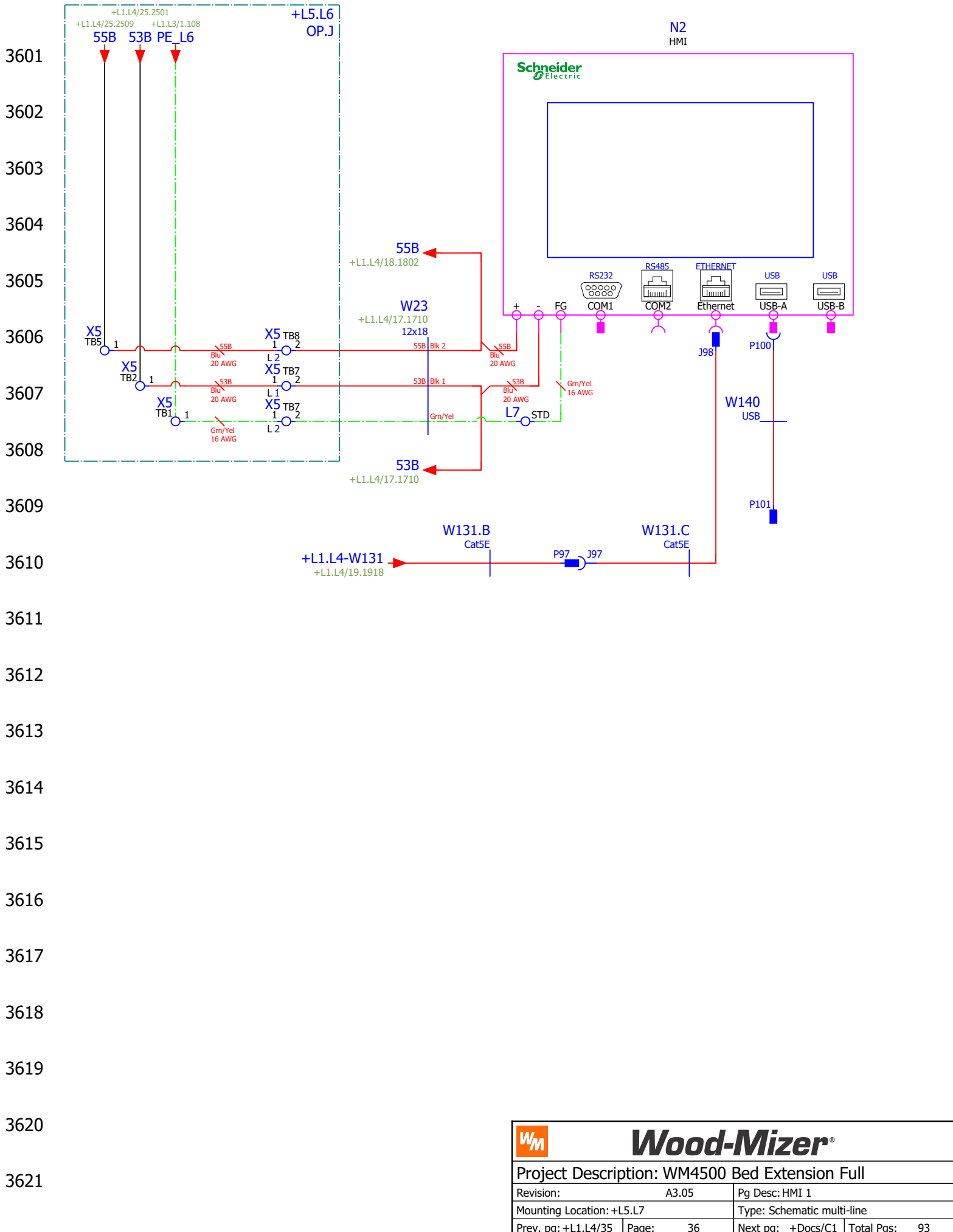

3601
3602
3603
3604
3605
3606
3607
3608
3609
3610
3611
3612
3613
3614
3615
3616
3617
3618
3619
3620
3621

Device Tag/Parts List

Device tag	Function	Wood-Mizer Part Number	Wood-Mizer Description	Qty.	X-Ref
1M1	Blade Motor Bypass Contactor	052465	Contacto, 32A 3P 24VDC Coil	1	+L1.L4/16.1603
2M1	Hydraulic Pump Motor Contactor	069866	Contacto, 25A 3P 24V Low Pwr Coil	1	+L1.L4/26.2606
4M1	Debarker Motor Contactor	024890	Contacto, 9A 3P 24VDC Coil	1	+L1.L4/26.2607
CAN1	CANopen Junction Box	069930	PLC Module, CANopen Junction	1	+L1.L4/19.1903
E1	Ethernet Switch	078466	Switch, Ethernet 5 Port 24VDC	1	+L1.L4/19.1916
ENC1	Feed Encoder	112573	Encoder Assy, Ind. Mill Feed	1	+L1.L4/19.1911
F4	Transformer L1&L3 Fuses	068066	Fuse Holder, 2P Class CC Wire Clamps	1	+L1.L3/3.306
F4	=	069915	Fuse, 0.25A 600V KLDR Class CC	2	+L1.L3/3.306
F5	Transformer Output Fuse	068065	Fuse Holder, 1P Class CC Wire Clamps	1	+L1.L3/3.308
F5	=	069915	Fuse, 0.25A 600V KLDR Class CC	1	+L1.L3/3.308
F6	Feed Drive L1 Fuse	053717	Fuseholder, 60A Cube	1	+L1.L3/2.208
F6	=	069702	Fuse, 40A Class J Cube	1	+L1.L3/2.208
F7	Feed Drive L2 Fuse	053717	Fuseholder, 60A Cube	1	+L1.L3/2.209
F7	=	069702	Fuse, 40A Class J Cube	1	+L1.L3/2.209
F8	Feed Drive L3 Fuse	053717	Fuseholder, 60A Cube	1	+L1.L3/2.209
F8	=	069702	Fuse, 40A Class J Cube	1	+L1.L3/2.209
F9	Power Supply 1 L1&L3 Fuses	068066	Fuse Holder, 2P Class CC Wire Clamps	1	+L1.L3/3.311
F9	=	052381	Fuse, 8A 600V Class CC Delay	2	+L1.L3/3.311
F10	Power Supply 2 L1&L3 Fuses	068066	Fuse Holder, 2P Class CC Wire Clamps	1	+L1.L3/3.316
F10	=	052713	Fuse, 4A 600V Calss CC Delay	2	+L1.L3/3.316
F11	Hydraulic Pump Motor L1 Fuse	053736	Fuseholder, Cube 30A	1	+L1.L3/2.202
F11	=	053737	Fuse, 30A Class J Cube	1	+L1.L3/2.202
F12	Hydraulic Pump Motor L2 Fuse	053736	Fuseholder, Cube 30A	1	+L1.L3/2.203
F12	=	053737	Fuse, 30A Class J Cube	1	+L1.L3/2.203
F13	Hydraulic Pump Motor L3 Fuse	053736	Fuseholder, Cube 30A	1	+L1.L3/2.203
F13	=	053737	Fuse, 30A Class J Cube	1	+L1.L3/2.203
F14	Up/Down Servo Drive L1 Fuse	053736	Fuseholder, Cube 30A	1	+L1.L3/2.216
F14	=	053737	Fuse, 30A Class J Cube	1	+L1.L3/2.216
F15	Up/Down Servo Drive L2 Fuse	053736	Fuseholder, Cube 30A	1	+L1.L3/2.217
F15	=	053737	Fuse, 30A Class J Cube	1	+L1.L3/2.217
F16	Up/Down Servo Drive L3 Fuse	053736	Fuseholder, Cube 30A	1	+L1.L3/2.218
F16	=	053737	Fuse, 30A Class J Cube	1	+L1.L3/2.218
F17	Blade Motor L1 Fuse	053586	Fuseholder, 100A Cube	1	+L1.L3/1.117
F17	=	069708	Fuse, 60A Class J Cube	1	+L1.L3/1.117
F18	Blade Motor L2 Fuse	053586	Fuseholder, 100A Cube	1	+L1.L3/1.116
F18	=	069708	Fuse, 60A Class J Cube	1	+L1.L3/1.116
F19	Blade Motor L3 Fuse	053586	Fuseholder, 100A Cube	1	+L1.L3/1.116
F19	=	069708	Fuse, 60A Class J Cube	1	+L1.L3/1.116
G1	DC Motor/ Solenoids Power Supply	078012	Power Supply, 24VDC 20A 200-500V	1	+L1.L3/3.310
G2	Control Power Supply	078193	Power Supply, 24VDC 10A 200-500V	1	+L1.L3/3.315
HM1	Blade Motor Hour Meter	P09631	Meter, Hour	1	+L1.L4/16.1607
JS1	Left Joystick	078360	Joystick, 4-Button w/4-Way Switch	1	+L1.L4/24.2402
JS2	Right Joystick	078360	Joystick, 4-Button w/4-Way Switch	1	+L1.L4/25.2502
K1	Isolation Contactor	069886	Contacto, 115A 3P 24VDC Coil	1	+L1.L4/16.1602
K2	Aux. E-Stop Control	101241	Contacto, 9A 3P 24VDC 1NO	1	+L1.L4/18.1802
K4	Blade Guide In Contactor	024910	Contacto, 9A 2NC 2NO 24VDC Reversing	1	+L1.L4/26.2609
K5	Blade Guide Out Contactor	024910	Contacto, 9A 2NC 2NO 24VDC Reversing	1	+L1.L4/26.2611
K6	Lube Pump Motor Relay	069943	Relay, Solid State 8A DIN	1	+L1.L4/26.2613
K16	Blade Brake Solenoid Relay	068212	Relay, Solid State 2A 24VDC Coil Cage Clamp Base	1	+L1.L4/26.2615
K17	Blow Off Solenoid Relay	068212	Relay, Solid State 2A 24VDC Coil Cage Clamp Base	1	+L1.L4/27.2702
K18	Debarker In Solenoid Relay	068212	Relay, Solid State 2A 24VDC Coil Cage Clamp Base	1	+L1.L4/27.2704
K19	Laser Relay	068212	Relay, Solid State 2A 24VDC Coil Cage Clamp Base	1	+L1.L4/27.2706
K20	Drag Back Finders Up Solenoid Relay	068212	Relay, Solid State 2A 24VDC Coil Cage Clamp Base	1	+L1.L4/31.3109
K24	Clamp In Solenoid Relay	068212	Relay, Solid State 2A 24VDC Coil Cage Clamp Base	1	+L1.L4/27.2707
K25	Clamp Out Solenoid Relay	068212	Relay, Solid State 2A 24VDC Coil Cage Clamp Base	1	+L1.L4/27.2709
K26	Turner Up Solenoid Relay	068212	Relay, Solid State 2A 24VDC Coil Cage Clamp Base	1	+L1.L4/27.2711
K27	Turner Down Solenoid Relay	068212	Relay, Solid State 2A 24VDC Coil Cage Clamp Base	1	+L1.L4/27.2713

		Wood-Mizer®	
Project Description: WM4500 Bed Extension Full			
Revision:	A3.05	Pg Desc: Parts list	
Mounting Location:	+Docs	Type: Parts list	
Prev. pg:	+L5.L7/36	Page:	C1
		Next pg:	C2
		Total Pgs:	93

Device Tag/Parts List

WM_PARTS_LIST-Manual

Device tag	Function	Wood-Mizer Part Number	Wood-Mizer Description	Qty.	X-Ref
K28	Clamp Up Solenoid Relay	068212	Relay, Solid State 2A 24VDC Coil Cage Clamp Base	1	+L1.L4/27.2715
K29	Clamp Down Solenoid Relay	068212	Relay, Solid State 2A 24VDC Coil Cage Clamp Base	1	+L1.L4/28.2802
K30	Toe #1 Up Solenoid Relay	068212	Relay, Solid State 2A 24VDC Coil Cage Clamp Base	1	+L1.L4/28.2804
K31	Toe #1 Down Solenoid Relay	068212	Relay, Solid State 2A 24VDC Coil Cage Clamp Base	1	+L1.L4/28.2806
K32	Power Roller Tape Fwd Solenoid Relay	068212	Relay, Solid State 2A 24VDC Coil Cage Clamp Base	1	+L1.L4/28.2807
K33	Power Taper Roller Rev Solenoid Relay	068212	Relay, Solid State 2A 24VDC Coil Cage Clamp Base	1	+L1.L4/28.2809
K34	Toe #2 Up Solenoid Relay	068212	Relay, Solid State 2A 24VDC Coil Cage Clamp Base	1	+L1.L4/28.2811
K35	Toe #2 Down Solenoid Relay	068212	Relay, Solid State 2A 24VDC Coil Cage Clamp Base	1	+L1.L4/28.2813
K36	Toe #3 Up Solenoid Relay	068212	Relay, Solid State 2A 24VDC Coil Cage Clamp Base	1	+L1.L4/28.2815
K37	Toe#3 Down Solenoid Relay	068212	Relay, Solid State 2A 24VDC Coil Cage Clamp Base	1	+L1.L4/29.2902
K38	Side Supports Up Solenoid Relay	068212	Relay, Solid State 2A 24VDC Coil Cage Clamp Base	1	+L1.L4/29.2904
K39	Side Supports Down Solenoid Relay	068212	Relay, Solid State 2A 24VDC Coil Cage Clamp Base	1	+L1.L4/29.2906
K40	Conveyor Motor Solenoid Relay	068212	Relay, Solid State 2A 24VDC Coil Cage Clamp Base	1	+L1.L4/29.2907
K41	Turner Forward Solenoid Relay	068212	Relay, Solid State 2A 24VDC Coil Cage Clamp Base	1	+L1.L4/29.2909
K42	Turner Reverse Solenoid Relay	068212	Relay, Solid State 2A 24VDC Coil Cage Clamp Base	1	+L1.L4/29.2911
K43	Loader Up Solenoid Relay	068212	Relay, Solid State 2A 24VDC Coil Cage Clamp Base	1	+L1.L4/29.2913
K44	Loader Down Solenoid Relay	068212	Relay, Solid State 2A 24VDC Coil Cage Clamp Base	1	+L1.L4/29.2915
K45	Log Deck Forward Solenoid Relay	068212	Relay, Solid State 2A 24VDC Coil Cage Clamp Base	1	+L1.L4/30.3002
K46	Log Deck Reverse Solenoid Relay	068212	Relay, Solid State 2A 24VDC Coil Cage Clamp Base	1	+L1.L4/30.3004
K47	Dump Valve Solenoid Relay	068212	Relay, Solid State 2A 24VDC Coil Cage Clamp Base	1	+L1.L4/30.3006
K100	Bed Extension Diverter/ Blocking Sol. Rly	068212	Relay, Solid State 2A 24VDC Coil Cage Clamp Base	1	+L1.L4/30.3007
K101	Bed Ext Turner Fwd/ Rev Diverter Relay	068212	Relay, Solid State 2A 24VDC Coil Cage Clamp Base	1	+L1.L4/11.1114
K102	Bed Ext Turner Fwd/ Rev Blocking Relay	068212	Relay, Solid State 2A 24VDC Coil Cage Clamp Base	1	+L1.L4/11.1115
K103	Bed Ext Side Support Up/Dn Diverter Rly	068212	Relay, Solid State 2A 24VDC Coil Cage Clamp Base	1	+L1.L4/11.1117
K104	Bed Ext Side Support Up/Dn Blocking Rly	068212	Relay, Solid State 2A 24VDC Coil Cage Clamp Base	1	+L1.L4/11.1118
K105	Bed Ext Turner Up/Dn Diverter Relay	068212	Relay, Solid State 2A 24VDC Coil Cage Clamp Base	1	+L1.L4/12.1202
K106	Bed Ext Pwr Taper Fwd/Rev Diverter Rly	068212	Relay, Solid State 2A 24VDC Coil Cage Clamp Base	1	+L1.L4/12.1203
K107	Bed Ext Pwr Taper Fwd/Rev Blocking Rly	068212	Relay, Solid State 2A 24VDC Coil Cage Clamp Base	1	+L1.L4/12.1205
K108	Bed Ext Loader Up/Dn Diverter Relay	068212	Relay, Solid State 2A 24VDC Coil Cage Clamp Base	1	+L1.L4/12.1206
K109	Bed Ext Loader Up/Dn Blocking Relay	068212	Relay, Solid State 2A 24VDC Coil Cage Clamp Base	1	+L1.L4/12.1208
K110	Bed Ext Log Deck Fwd/Rev Diverter Rly	068212	Relay, Solid State 2A 24VDC Coil Cage Clamp Base	1	+L1.L4/12.1209
K111	Bed Ext Log Deck Fwd/Rev Blocking Rly	068212	Relay, Solid State 2A 24VDC Coil Cage Clamp Base	1	+L1.L4/12.1211
K112	Bed Ext Clamp Up Diverter Solenoid	068212	Relay, Solid State 2A 24VDC Coil Cage Clamp Base	1	+L1.L4/12.1213
K113	Bed Ext Clamp Down Diverter Solenoid	068212	Relay, Solid State 2A 24VDC Coil Cage Clamp Base	1	+L1.L4/12.1214
K114	Bed Ext Clamp In Diverter Solenoid	068212	Relay, Solid State 2A 24VDC Coil Cage Clamp Base	1	+L1.L4/12.1216
K115	Bed Ext Clamp Out Diverter Solenoid	068212	Relay, Solid State 2A 24VDC Coil Cage Clamp Base	1	+L1.L4/12.1217
K120	Bed Extension Clamp Selector Relay	068212	Relay, Solid State 2A 24VDC Coil Cage Clamp Base	1	+L1.L4/31.3111
K150	Bed Extension Toe #4 Up Solenoid Relay	068212	Relay, Solid State 2A 24VDC Coil Cage Clamp Base	1	+L1.L4/30.3009
K151	Bed Extension Toe #4 Down Solenoid Rly	068212	Relay, Solid State 2A 24VDC Coil Cage Clamp Base	1	+L1.L4/30.3011
K152	Bed Extension Clamp Up Solenoid Relay	068212	Relay, Solid State 2A 24VDC Coil Cage Clamp Base	1	+L1.L4/30.3013
K153	Bed Extension Clamp Down Solenoid Rly	068212	Relay, Solid State 2A 24VDC Coil Cage Clamp Base	1	+L1.L4/30.3015
K154	Bed Extension Clamp In Solenoid Relay	068212	Relay, Solid State 2A 24VDC Coil Cage Clamp Base	1	+L1.L4/31.3102
K155	Bed Extension Clamp Out Solenoid Relay	068212	Relay, Solid State 2A 24VDC Coil Cage Clamp Base	1	+L1.L4/31.3104
LAS1	Laser	068035	Laser, 5mW 532nm 90 Deg Line Z-Laser Grn	1	+L1.L4/8.813
M1	Blade Motor	042301	Motor, 30HP 1800RPM	1	+L1.L3/1.115
M2	Hydraulic Pump Motor	078670	Motor, 15HP 230/460 3PH 60Hz	1	+L1.L3/2.202
M3	Feed Motor	115152	Motor, 5HP 3P 230/460 184TC	1	+L1.L3/2.208
M4	Up/Down Servo Motor	068038	Motor, Servo 100mm IP54 Encoder	1	+L1.L3/2.213
M5	Debarker Motor	050292	Motor, 3/4HP 230/460 3P 1725RPM DB LT60	1	+L1.L3/3.302
M6	Blade Guide Motor	035659	Motor Assy, 24V 60 RPM Gear	1	+L1.L4/7.716
MCR1	Master Control Relay	051322	Contact, 25A 3P 24VDC Coil	1	+L1.L4/17.1716
N2	HMI	078794	HMI Assy, Ind. Mill	1	+L5.L7/36.3601
N3	Hydraulic Pwr Unit Proportional Valve Ctrl	068277	Driver Assy, Prop Valve 8 Pin A2.00+	1	+L1.L4/34.3406
OL2	Hydraulic Pump Motor Overload	069885	Overload, 16-24A Class 10 Single Ph Sens	1	+L1.L3/2.202
PB1	E-Stop	068940	Pushbutton Head, 22mm E-Stop Twist-Pull	1	+L1.L4/17.1710
PB1	=	068950	Collar, Mount 1NC ZB5	1	+L1.L4/17.1710
PB1	=	068921	Contact Block, NC ZB5	1	+L1.L4/17.1710

		Wood-Mizer®	
Project Description: WM4500 Bed Extension Full			
Revision:	A3.05	Pg Desc: Parts list	
Mounting Location: +Docs		Type: Parts list	
Prev. pg:	C1	Page:	C2
Next pg:	C3	Total Pgs:	93

Terminal line-up diagram

Terminal strip +L1.L3-X2

Terminal				Jumper		End Plate	Remark	Terminal X-Ref
Ref. Des.	Level	P/N	Description	Diagram	P/N	P/N		
TB1		068106	Terminal Block, 2Pos 4mm Clamp	•				&MEA+.L4/22.09
TB2		068106	Terminal Block, 2Pos 4mm Clamp	•		068108		&MEA+.L4/22.09
TB3		068106	Terminal Block, 2Pos 4mm Clamp	●				&MEA+.L4/22.11
TB4		068106	Terminal Block, 2Pos 4mm Clamp	●		068108		&MEA+.L4/22.11

		Wood-Mizer®	
Project Description: WM4500 Bed Extension Full			
Revision:		A3.05	Pg Desc: Terminal line-up diagram
Mounting Location: +Docs		Type: Terminal line-up diagram	
Prev. pg:	C3	Page:	D1
Next pg:	D2	Total Pgs:	93

Terminal line-up diagram

Terminal strip +L1.L4-X4

Terminal				Jumper		End Plate	Remark	Terminal X-Ref
Ref. Des.	Level	P/N	Description	Diagram	P/N	P/N		
TB1		068104	Terminal Block, 4Pos 1.5mm GND Clamp					&MEA+.L3/1.05
TB2		068104	Terminal Block, 4Pos 1.5mm GND Clamp					&MEA+.L3/1.05
TB3		068104	Terminal Block, 4Pos 1.5mm GND Clamp					&MEA+.L3/1
TB4		068103	Terminal Block, 4Pos 1.5mm Com Clamp	●	068113		Jumper is Trimmed Down To 3 Position Jumper Between TB4-6	&MEA+.L3/3.12
TB5		068103	Terminal Block, 4Pos 1.5mm Com Clamp	●				&MEA/12.18
TB6		068103	Terminal Block, 4Pos 1.5mm Com Clamp	●				&MEA/12
TB7		068103	Terminal Block, 4Pos 1.5mm Com Clamp	●	068113		Jumper is Trimmed Down To 2 Position Jumper Between TB7-8	&MEA+.L3/3.11
TB8		068103	Terminal Block, 4Pos 1.5mm Com Clamp	●	068113		Jumper is Trimmed Down To 2 Position Jumper Between TB7-8	&MEA+.L3/3
TB9		068103	Terminal Block, 4Pos 1.5mm Com Clamp	●	068113		Jumper is Trimmed Down To 3 Position Jumper Between TB9-11	&MEA/7.06
TB10		068103	Terminal Block, 4Pos 1.5mm Com Clamp	●				&MEA/16.02
TB11		068103	Terminal Block, 4Pos 1.5mm Com Clamp	●				&MEA/16
TB12		068103	Terminal Block, 4Pos 1.5mm Com Clamp	●	068113		Jumper is Trimmed Down To 8 Position Between TB12-19	&MEA+.L3/3.17
TB13		068103	Terminal Block, 4Pos 1.5mm Com Clamp	●				&MEA/26.15
TB14		068103	Terminal Block, 4Pos 1.5mm Com Clamp	●				&MEA/30.06
TB15		068103	Terminal Block, 4Pos 1.5mm Com Clamp	●				&MEA/16.07
TB16		068103	Terminal Block, 4Pos 1.5mm Com Clamp	●				&MEA+.L3/6.06
TB17		068103	Terminal Block, 4Pos 1.5mm Com Clamp	●				&MEA/26.06
TB18		068103	Terminal Block, 4Pos 1.5mm Com Clamp	●				&MEA/7
TB19		068103	Terminal Block, 4Pos 1.5mm Com Clamp	●		068105		&MEA/7
TB20		068103	Terminal Block, 4Pos 1.5mm Com Clamp	●	068113		Jumper is Trimmed Down To 5 Position Between TB20-24	&MEA+.L3/3.16
TB21		068103	Terminal Block, 4Pos 1.5mm Com Clamp	●				&MEA/7.03
TB22		068103	Terminal Block, 4Pos 1.5mm Com Clamp	●				&MEA/21.02
TB23		068103	Terminal Block, 4Pos 1.5mm Com Clamp	●				&MEA+.L3/6.05
TB24		068103	Terminal Block, 4Pos 1.5mm Com Clamp	●		068105		&MEA/7
TB25		068103	Terminal Block, 4Pos 1.5mm Com Clamp	●	068113		Jumper is Trimmed Down To 2 Position Jumper Between TB25-26	&MEA/21
TB26		068103	Terminal Block, 4Pos 1.5mm Com Clamp	●		068105		&MEA+.L3/6.02



Wood-Mizer®

Project Description: WM4500 Bed Extension Full

Revision: A3.05 Pg Desc: Terminal line-up diagram

Mounting Location: +Docs Type: Terminal line-up diagram

Prev. pg: D1 Page: D2 Next pg: D3 Total Pgs: 93

Terminal line-up diagram

Wood-Mizer_Terminal_Lineup_Diagram

Terminal strip +L5.L6-X5

Terminal				Jumper		End Plate	Remark	Terminal
Ref. Des.	Level	P/N	Description	Diagram	P/N	P/N		X-Ref
TB1		068104	Terminal Block, 4Pos 1.5mm GND Clamp	⋮		068105		&MEA+.L7/36.08
TB2		068103	Terminal Block, 4Pos 1.5mm Com Clamp	●	068113		Jumper is Trimmed Down To 2 Position Between TB2-3	&MEA+.L7/36.07
TB3		068103	Terminal Block, 4Pos 1.5mm Com Clamp	●				&MEA+L1.L4/18.02
TB4		068103	Terminal Block, 4Pos 1.5mm Com Clamp	●	068113		Jumper is Trimmed Down To 2 Position Between TB4-5	&MEA+L1.L4/23.02
TB5		068103	Terminal Block, 4Pos 1.5mm Com Clamp	●		068105		&MEA+.L7/36.06
TB6	1	068119	Terminal Block, 2 Tier 2.5mm Clamp	⋮		068120		&MEA+L1.L4/17.05
TB6	2			⋮				&MEA+L1.L4/17.05
TB7	1	068119	Terminal Block, 2 Tier 2.5mm Clamp	⋮				&MEA+.L7/36.07
TB7	2			⋮				&MEA+.L7/36.08
TB8	1	068119	Terminal Block, 2 Tier 2.5mm Clamp	⋮				&MEA+L1.L4/17.07
TB8	2			⋮				&MEA+.L7/36.06
TB9	1	068119	Terminal Block, 2 Tier 2.5mm Clamp	⋮				&MEA+L1.L4/17.12
TB9	2			⋮				&MEA+L1.L4/17.12
TB10	1	068119	Terminal Block, 2 Tier 2.5mm Clamp	⋮				&MEA+L1.L4/22.06
TB10	2			⋮				&MEA+L1.L4/22.04
TB11	1	068119	Terminal Block, 2 Tier 2.5mm Clamp	⋮		068120		&MEA+L1.L4/18.02
TB11	2			⋮				
TB12	1	068119	Terminal Block, 2 Tier 2.5mm Clamp	⋮				&MEA+L1.L4/24.03
TB12	2			⋮				&MEA+L1.L4/24.03
TB13	1	068119	Terminal Block, 2 Tier 2.5mm Clamp	⋮				&MEA+L1.L4/24.04
TB13	2			⋮				&MEA+L1.L4/24.04
TB14	1	068119	Terminal Block, 2 Tier 2.5mm Clamp	⋮				&MEA+L1.L4/24.06
TB14	2			⋮				&MEA+L1.L4/24.05
TB15	1	068119	Terminal Block, 2 Tier 2.5mm Clamp	⋮				&MEA+L1.L4/24.08
TB15	2			⋮				&MEA+L1.L4/24.06
TB16	1	068119	Terminal Block, 2 Tier 2.5mm Clamp	⋮				&MEA+L1.L4/24.08
TB16	2			⋮				&MEA+L1.L4/24.09
TB17	1	068119	Terminal Block, 2 Tier 2.5mm Clamp	⋮		068120		&MEA+L1.L4/24.07
TB17	2			⋮				&MEA+L1.L4/24.09
TB18	1	068119	Terminal Block, 2 Tier 2.5mm Clamp	⋮				&MEA+L1.L4/25.03
TB18	2			⋮				&MEA+L1.L4/25.03
TB19	1	068119	Terminal Block, 2 Tier 2.5mm Clamp	⋮				&MEA+L1.L4/25.04
TB19	2			⋮				&MEA+L1.L4/25.04
TB20	1	068119	Terminal Block, 2 Tier 2.5mm Clamp	⋮				&MEA+L1.L4/25.06
TB20	2			⋮				&MEA+L1.L4/25.05



Wood-Mizer®

Project Description: WM4500 Bed Extension Full

Revision:	A3.05	Pg Desc:	Terminal line-up diagram
Mounting Location:	+Docs	Type:	Terminal line-up diagram
Prev. pg:	D2	Page:	D3
		Next pg:	D4
		Total Pgs:	93

Terminal line-up diagram

Wood-Mizer_Terminal_Lineup_Diagram

Terminal strip +L5.L6-X5

Terminal				Jumper		End Plate	Remark	Terminal
Ref. Des.	Level	P/N	Description	Diagram	P/N	P/N		X-Ref
TB21	1	068119	Terminal Block, 2 Tier 2.5mm Clamp	┆				&MEA+L1.L4/25.08
TB21	2			┆				&MEA+L1.L4/25.06
TB22	1	068119	Terminal Block, 2 Tier 2.5mm Clamp	┆				&MEA+L1.L4/25.08
TB22	2			┆				&MEA+L1.L4/25.09
TB23	1	068119	Terminal Block, 2 Tier 2.5mm Clamp	┆		068120		&MEA+L1.L4/25.07
TB23	2			┆				&MEA+L1.L4/25.09
TB24	1	068119	Terminal Block, 2 Tier 2.5mm Clamp	┆				&MEA+L1.L4/23.02
TB24	2			┆				&MEA+L1.L4/23.02
TB25	1	068119	Terminal Block, 2 Tier 2.5mm Clamp	┆		068120		
TB25	2			┆				&MEA+L1.L4/23.03
TB26	1	068119	Terminal Block, 2 Tier 2.5mm Clamp	┆				&MEA+L1.L4/17.07
TB26	2			┆				&MEA+L1.L4/17.07
TB27	1	068119	Terminal Block, 2 Tier 2.5mm Clamp	┆				&MEA+L1.L4/17.07
TB27	2			┆				&MEA+L1.L4/17.07
TB28	1	068119	Terminal Block, 2 Tier 2.5mm Clamp	┆				&MEA+L1.L4/17.07
TB28	2			┆				&MEA+L1.L4/17.07
TB29	1	068119	Terminal Block, 2 Tier 2.5mm Clamp	┆		068120		&MEA+L1.L4/18.05
TB29	2			┆				&MEA+L1.L4/18.03
TB30	1	068119	Terminal Block, 2 Tier 2.5mm Clamp	┆		068120		&MEA+L1.L4/18
TB30	2			┆				&MEA+L1.L4/18.05
TB31	1	068119	Terminal Block, 2 Tier 2.5mm Clamp	┆				&MEA+L1.L4/15
TB31	2			┆				&MEA+L1.L4/15
TB32	1	068119	Terminal Block, 2 Tier 2.5mm Clamp	┆		068120		&MEA+L1.L4/15
TB32	2			┆				



Wood-Mizer®

Project Description: WM4500 Bed Extension Full

Revision: A3.05 Pg Desc: Terminal line-up diagram

Mounting Location: +Docs Type: Terminal line-up diagram

Prev. pg: D3 Page: D4 Next pg: D5 Total Pgs: 93

Terminal line-up diagram

Wood-Mizer_Terminal_Lineup_Diagram

Terminal strip +L11.L12-X6

Terminal				Jumper		End Plate	Remark	Terminal X-Ref
Ref. Des.	Level	P/N	Description	Diagram	P/N	P/N		
TB1		068104	Terminal Block, 4Pos 1.5mm GND Clamp					&MEA+L1.L3/1.09
TB2		068104	Terminal Block, 4Pos 1.5mm GND Clamp			068105		&MEA+L1.L4/19.12
TB3		068103	Terminal Block, 4Pos 1.5mm Com Clamp	●	068113		Jumper is Trimmed Down To 2 Position Between TB3-4	&MEA+L1.L4/8.05
TB4		068103	Terminal Block, 4Pos 1.5mm Com Clamp	●		068105		&MEA+L1.L4/8.13
TB5		068103	Terminal Block, 4Pos 1.5mm Com Clamp	●	068113		Jumper is Trimmed Down To 3 Position Between TB5-7	&MEA+L1.L4/16.09
TB6		068103	Terminal Block, 4Pos 1.5mm Com Clamp	●				&MEA+L1.L4/26.02
TB7		068103	Terminal Block, 4Pos 1.5mm Com Clamp	●		068105		&MEA+L1.L4/19.12
TB8		068103	Terminal Block, 4Pos 1.5mm Com Clamp	●	068113		Jumper is Trimmed Down To 2 Position Between TB8-9	&MEA+L1.L4/23.07
TB9		068103	Terminal Block, 4Pos 1.5mm Com Clamp	●		068105		&MEA+L1.L4/23.06
TB10	1	068119	Terminal Block, 2 Tier 2.5mm Clamp					&MEA+L1.L4/17.02
TB10	2							&MEA+L1.L4/17.02
TB11	1	068119	Terminal Block, 2 Tier 2.5mm Clamp					&MEA+L1.L4/17.02
TB11	2							&MEA+L1.L4/17.02
TB12	1	068119	Terminal Block, 2 Tier 2.5mm Clamp					&MEA+L1.L4/7.15
TB12	2							&MEA+L1.L4/7.17
TB13	1	068119	Terminal Block, 2 Tier 2.5mm Clamp					&MEA+L1.L4/8.09
TB13	2							&MEA+L1.L4/8.07
TB14	1	068119	Terminal Block, 2 Tier 2.5mm Clamp					
TB14	2							&MEA+L1.L4/8.11
TB15	1	068119	Terminal Block, 2 Tier 2.5mm Clamp					
TB15	2							&MEA+L1.L4/8.13
TB16	1	068119	Terminal Block, 2 Tier 2.5mm Clamp			068120		&MEA+L1.L4/23.13
TB16	2							&MEA+L1.L4/23.10
TB17	1	068119	Terminal Block, 2 Tier 2.5mm Clamp					&MEA+L1.L4/8
TB17	2							&MEA+L1.L4/8.16



Wood-Mizer®

Project Description: WM4500 Bed Extension Full

Revision: A3.05 Pg Desc: Terminal line-up diagram

Mounting Location: +Docs Type: Terminal line-up diagram

Prev. pg: D4 Page: D5 Next pg: D6 Total Pgs: 93

Terminal line-up diagram

Wood-Mizer_Terminal_Lineup_Diagram

Terminal strip +L9.L10-X7

Terminal				Jumper		End Plate	Remark	Terminal
Ref. Des.	Level	P/N	Description	Diagram	P/N	P/N		X-Ref
TB1		068104	Terminal Block, 4Pos 1.5mm GND Clamp					&MEA+L1.L3/1.08
TB2		068104	Terminal Block, 4Pos 1.5mm GND Clamp					&MEA+L1.L4/9.04
TB3		068104	Terminal Block, 4Pos 1.5mm GND Clamp					&MEA+L1.L4/9.07
TB4		068104	Terminal Block, 4Pos 1.5mm GND Clamp					&MEA+L1.L4/9.11
TB5		068104	Terminal Block, 4Pos 1.5mm GND Clamp			068105		&MEA+L1.L4/15.03
TB6		068103	Terminal Block, 4Pos 1.5mm Com Clamp	●	068113		Jumper is Trimmed Down To 5 Position Between TB6-10	&MEA+L1.L4/9.02
TB7		068103	Terminal Block, 4Pos 1.5mm Com Clamp	●				&MEA+L1.L4/9.02
TB8		068103	Terminal Block, 4Pos 1.5mm Com Clamp	●				&MEA+L1.L4/9.06
TB9		068103	Terminal Block, 4Pos 1.5mm Com Clamp	●				&MEA+L1.L4/9.09
TB11		068103	Terminal Block, 4Pos 1.5mm Com Clamp			068105		&MEA+L1.L4/16.12
TB12		068103	Terminal Block, 4Pos 1.5mm Com Clamp			068105		&MEA+L1.L4/16.12
TB13	1	068119	Terminal Block, 2 Tier 2.5mm Clamp					&MEA+L1.L4/9.02
TB13	2							&MEA+L1.L4/9.05
TB14	1	068119	Terminal Block, 2 Tier 2.5mm Clamp					&MEA+L1.L4/9.06
TB14	2							&MEA+L1.L4/9.08
TB15	1	068119	Terminal Block, 2 Tier 2.5mm Clamp					&MEA+L1.L4/9.09
TB15	2							&MEA+L1.L4/9.12
TB16	1	068119	Terminal Block, 2 Tier 2.5mm Clamp					&MEA+L1.L4/9.13
TB16	2							&MEA+L1.L4/9.15
TB17	1	068119	Terminal Block, 2 Tier 2.5mm Clamp					&MEA+L1.L4/9.16
TB17	2							&MEA+L1.L4/9.19
TB18	1	068119	Terminal Block, 2 Tier 2.5mm Clamp					&MEA+L1.L4/10.02
TB18	2							&MEA+L1.L4/10.04
TB19	1	068119	Terminal Block, 2 Tier 2.5mm Clamp					&MEA+L1.L4/10.05
TB19	2							&MEA+L1.L4/10.08
TB20	1	068119	Terminal Block, 2 Tier 2.5mm Clamp					&MEA+L1.L4/10.09
TB20	2							&MEA+L1.L4/10.11
TB21	1	068119	Terminal Block, 2 Tier 2.5mm Clamp					&MEA+L1.L4/10.12
TB21	2							
TB22	1	068119	Terminal Block, 2 Tier 2.5mm Clamp					&MEA+L1.L4/10.15
TB22	2							&MEA+L1.L4/10.17
TB23	1	068119	Terminal Block, 2 Tier 2.5mm Clamp					&MEA+L1.L4/11.02
TB23	2							&MEA+L1.L4/11.04
TB24	1	068119	Terminal Block, 2 Tier 2.5mm Clamp					&MEA+L1.L4/11.05
TB24	2							&MEA+L1.L4/11.07



Wood-Mizer®

Project Description: WM4500 Bed Extension Full

Revision: A3.05 Pg Desc: Terminal line-up diagram

Mounting Location: +Docs Type: Terminal line-up diagram

Prev. pg: D5 Page: D6 Next pg: D7 Total Pgs: 93

Terminal line-up diagram

Terminal strip +L9.L10-X7

Terminal				Jumper		End Plate	Remark	Terminal X-Ref
Ref. Des.	Level	P/N	Description	Diagram	P/N	P/N		
TB25	1	068119	Terminal Block, 2 Tier 2.5mm Clamp	•				&MEA+L1.L4/34.07
TB25	2			•				&MEA+L1.L4/34.08
TB26	1	068119	Terminal Block, 2 Tier 2.5mm Clamp	•				&MEA+L1.L4/11.09
TB26	2			•				
TB27	1	068119	Terminal Block, 2 Tier 2.5mm Clamp	•				&MEA+L1.L4/15.02
TB27	2			•				&MEA+L1.L4/15.04
TB28	1	068119	Terminal Block, 2 Tier 2.5mm Clamp	•				&MEA+L1.L4/15.05
TB28	2			•				&MEA+L1.L4/15.08
TB29	1	068119	Terminal Block, 2 Tier 2.5mm Clamp	•		068102		&MEA+L1.L4/15.09
TB29	2			•				&MEA+L1.L4/15.11



Wood-Mizer®

Project Description: WM4500 Bed Extension Full

Revision: A3.05 Pg Desc: Terminal line-up diagram

Mounting Location: +Docs Type: Terminal line-up diagram

Prev. pg: D6 Page: D7 Next pg: D8 Total Pgs: 93

Terminal line-up diagram

Terminal strip +L5.L14-X8

Terminal				Jumper		End Plate	Remark	Terminal X-Ref
Ref. Des.	Level	P/N	Description	Diagram	P/N	P/N		
TB1		068104	Terminal Block, 4Pos 1.5mm GND Clamp					&MEA+L1.L3/1.08
TB2		068104	Terminal Block, 4Pos 1.5mm GND Clamp					&MEA+L1.L4/13.03
TB3		068104	Terminal Block, 4Pos 1.5mm GND Clamp					&MEA+L1.L4/13.05
TB4		068104	Terminal Block, 4Pos 1.5mm GND Clamp			068105		&MEA+L1.L4/13.07
TB5		068103	Terminal Block, 4Pos 1.5mm Com Clamp	●	068113		Jumper is Trimmed Down To 4 Position Between TB5-8	&MEA+L1.L4/11.13
TB6		068103	Terminal Block, 4Pos 1.5mm Com Clamp	●				&MEA+L1.L4/11.14
TB7		068103	Terminal Block, 4Pos 1.5mm Com Clamp	●				&MEA+L1.L4/13.02
TB8		068103	Terminal Block, 4Pos 1.5mm Com Clamp	●		068105		&MEA+L1.L4/13.04
TB9		068103	Terminal Block, 4Pos 1.5mm Com Clamp	●				&MEA+L1.L4/14.12

		Wood-Mizer®	
Project Description: WM4500 Bed Extension Full			
Revision: A3.05		Pg Desc: Terminal line-up diagram	
Mounting Location: +Docs		Type: Terminal line-up diagram	
Prev. pg: D7	Page: D8	Next pg: E1	Total Pgs: 93

Cable Overview

Wood-Mizer_Cable_Overview

Cable Designation	Cable Part Number	Cable Description	Cable X-Ref
W1	069958-FX	Cable Assy, Ind. Mill Blade Mtr Full Ex	+L1.L3/1.118
W2	069993	Cable Assy, Ind. Mill Hydraulic Mtr	+L1.L3/2.202
W3	078442-FX	Cable Assy, Ind. Mill Feed Mtr Full Ex	+L1.L3/2.208
W4	068179	Cable Assy, Ind. Mill Up/Dn Servo Mtr	+L1.L3/2.214
W5	068180	Cable Assy, Ind. Mill Up/Dn Servo Enc	+L1.L3/2.213
W6	069959	Cable Assy, Ind. Mill Debarker Motor	+L1.L3/3.302
W20	069962-FX	Cable Assy, Ind. Mill Head Box Full Ex	+L1.L4/7.708
W21	078656	Cable Assy, Ind. Mill Hydraulic Control	+L1.L4/10.1002
W22	078657	Cable Assy, Ind. Mill Operator Junction	+L1.L4/16.1616
W23	078658	Cable Assy, Ind. Mill HMI Control	+L1.L4/17.1710
W30	078659	Cable Assy, Ind. Mill Left Joystick	+L1.L4/24.2403
W31	078660	Cable Assy, Ind. Mill Right Joystick	+L1.L4/25.2503
W34	069963	Cable Assy, Ind. Mill Seat Switch	+L1.L4/17.1705
W35	078661	Cable Assy, Ind. Mill Foot Pedal	+L1.L4/23.2302
W36	078662	Cable Assy, Ind. Mill Blade Break Prox	+L1.L4/23.2310
W37	078663	Cable Assy, Ind. Mill Ball Nut Prox	+L1.L4/23.2312
W38	069988	Cable Assy, Ind. Mill Blade Guide Motor	+L1.L4/7.715
W39	068074	Cable Assy, Ind. Mill Laser	+L1.L4/8.813
W40	068048	Cable Assy, Ind. Mill Feed Encoder Pwr	+L1.L4/19.1911
W40A	068206	Connector Assy, Ind. Mill Feed Encoder	+L1.L4/19.1911
W41	078791	Cable Assy, Drag Back Solenoid	+L1.L4/8.802
W42	078665	Cable Assy, Ind. Mill Prop Valve	+L1.L4/34.3407
W61	069977	Cable Assy, Ind. Mill Bld Brk Sol.	+L1.L4/8.807
W62	069978	Cable Assy, Ind. Mill Blw Off Sol.	+L1.L4/8.809
W63	069979	Cable Assy, Ind. Mill Debarker Sol.	+L1.L4/8.811
W64	069966	Cable Assy, Ind. Mill Clamp In/Out Sol	+L1.L4/9.902
W65	069967	Cable Assy, Ind. Mill Turner Up/Dn Sol.	+L1.L4/9.906
W66	069968	Cable Assy, Ind. Mill Clamp Up/Dn Sol.	+L1.L4/9.909
W67	069969	Cable Assy, Ind. Mill Toe #1 Up/Dn Sol.	+L1.L4/9.913
W68	069970	Cable Assy, Ind. Mill Pwr Tpr Fwd/Rv Sol.	+L1.L4/9.916
W69	069971	Cable Assy, Ind. Mill Toe #2 Up/Dn Sol.	+L1.L4/10.1002
W70	069972	Cable Assy, Ind. Mill Toe #3 Up/Dn Sol.	+L1.L4/10.1005
W71	069973	Cable Assy, Ind. Mill Sd Sup Up/Dn Sol.	+L1.L4/10.1009
W72	068189	Cable Assy, Ind. Mill Conveyor Sol.	+L1.L4/10.1012
W73	069974	Cable Assy, Ind. Mill Pwr Tpr Fwd/Rv Sol.	+L1.L4/10.1014

		Wood-Mizer®	
Project Description: WM4500 Bed Extension Full			
Revision:	A3.05	Pg Desc: Cable overview	
Mounting Location: +Docs		Type: Cable overview	
Prev. pg:	D8	Page:	E1
Next pg:		E2	Total Pgs: 93

Cable Overview

Cable Designation	Cable Part Number	Cable Description	Cable X-Ref
W74	069975	Cable Assy, Ind. Mill Loader Up/Dn Sol.	+L1.L4/11.1102
W75	069976	Cable Assy, Ind. Mill Log Deck Fwd/Rev S	+L1.L4/11.1105
W77	069978	Cable Assy, Ind. Mill Blw Off Sol.	+L1.L4/8.816
W100	069937	Cable Assy, Ind. Mill CANopen PLC	+L1.L4/21.2111
W101	069873	Cable Assy, Ind. Mill CANopen Feed Drive	+L1.L4/19.1902
W102	069874	Cable Assy, Ind. Mill CANopen Up/Dn Driv	+L1.L4/19.1902
W103.A	068029	Connector Assy, Ind. Mill CANopen Main	+L1.L4/19.1908
W103.B	068283	Cable Assy, Ind. Mill Encoder CAN	+L1.L4/19.1908
W120	069923	Cable Assy, Ind. Mill Modbus Soft Start	+L1.L4/21.2106
W130	068162	Cable Assy, Ind. Mill Ethernet PLC	+L1.L4/21.2108
W131.A	069888	Cable Assy, Ind. Mill Ethernet Main Inte	+L1.L4/19.1918
W131.B	069997	Cable Assy, Ind. Mill HMI Ethernet	+L5.L7/36.3610
W131.C	069986	Cable Assy, Ind. Mill Ethernet HMI Int	+L5.L7/36.3610
W140	068178	Receptacle, Panel Mount USB	+L5.L7/36.3608
W150	068291	Cable Assy, Ind. Mill BedX Toe Brd U/D	+L1.L4/15.1502
W151	068292	Cable Assy, Ind. Mill BedX Clamp U/D	+L1.L4/15.1505
W152	068293	Cable Assy, Ind. Mill BedX Clamp In/Out	+L1.L4/15.1509
W1000	068247	Cable Assy, Ind. Mill Hyd. Bed Ex	+L1.L4/11.1113
W1001	068248	Cable Assy, Ind. Mill BX Trn FR Div	+L1.L4/13.1302
W1002	068249	Cable Assy, Ind. Mill BX Trn FR Blk	+L1.L4/13.1304
W1003	068274	Cable Assy, Ind. Mill BX SS UD Div	+L1.L4/13.1306
W1004	068275	Cable Assy, Ind. Mill BX SS UD Blk	+L1.L4/13.1308
W1005	068276	Cable Assy, Ind. Mill BX Trn UD Div	+L1.L4/13.1310
W1006	068277	Cable Assy, Ind. Mill BX PT FR Div	+L1.L4/13.1312
W1007	068278	Cable Assy, Ind. Mill BX PT FR Blk	+L1.L4/13.1314
W1008	068280	Cable Assy, Ind. Mill BX LD UD Div	+L1.L4/13.1316
W1009	068288	Cable Assy, Ind. Mill BX LD UD Blk	+L1.L4/13.1318
W1010	068289	Cable Assy, Ind. Mill BX LD FR Div	+L1.L4/14.1402
W1011	068290	Cable Assy, Ind. Mill BX LD FR Blk	+L1.L4/14.1404
W1012	112434	Cable Assy, Ind. Mill BX Clmp Up Slct Sol.	+L1.L4/14.1406
W1013	112435	Cable Assy, Ind. Mill BX Clmp Dn Slct Sol.	+L1.L4/14.1408
W1014	112436	Cable Assy, Ind. Mill BX Clmp In Slct Sol.	+L1.L4/14.1410
W1015	112437	Cable Assy, Ind. Mill BX Clmp Out Slct Sol.	+L1.L4/14.1412
Z1	078785	Harness Assy, Ind. Mill Disconnect	+L1.L3/1.101
Z3	069935	Harness Assy, Ind. Mill Transformer	+L1.L3/3.306

		Wood-Mizer®	
Project Description: WM4500 Bed Extension Full			
Revision: A3.05		Pg Desc: Cable overview	
Mounting Location: +Docs		Type: Cable overview	
Prev. pg: E1	Page: E2	Next pg: F1	Total Pgs: 93



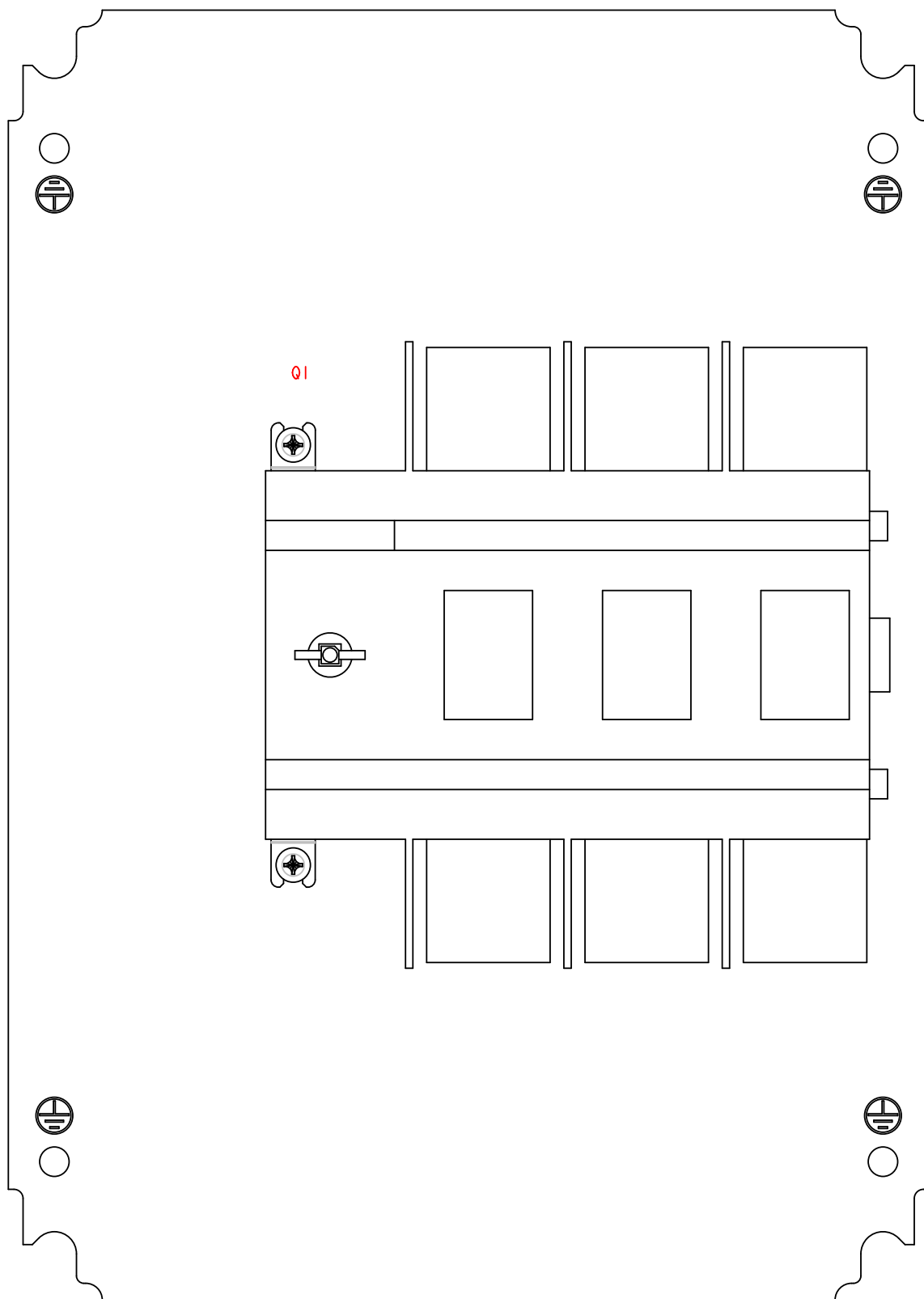

Wood-Mizer®

Project Description: WM4500 Bed Extension Full

Revision:	A3.05	Pg Desc: Main Control Disconnect Layout	
Mounting Location: +Docs		Type: Panel layout	
Prev. pg:	F1	Page:	F2
		Next pg:	F3
			Total Pgs: 93

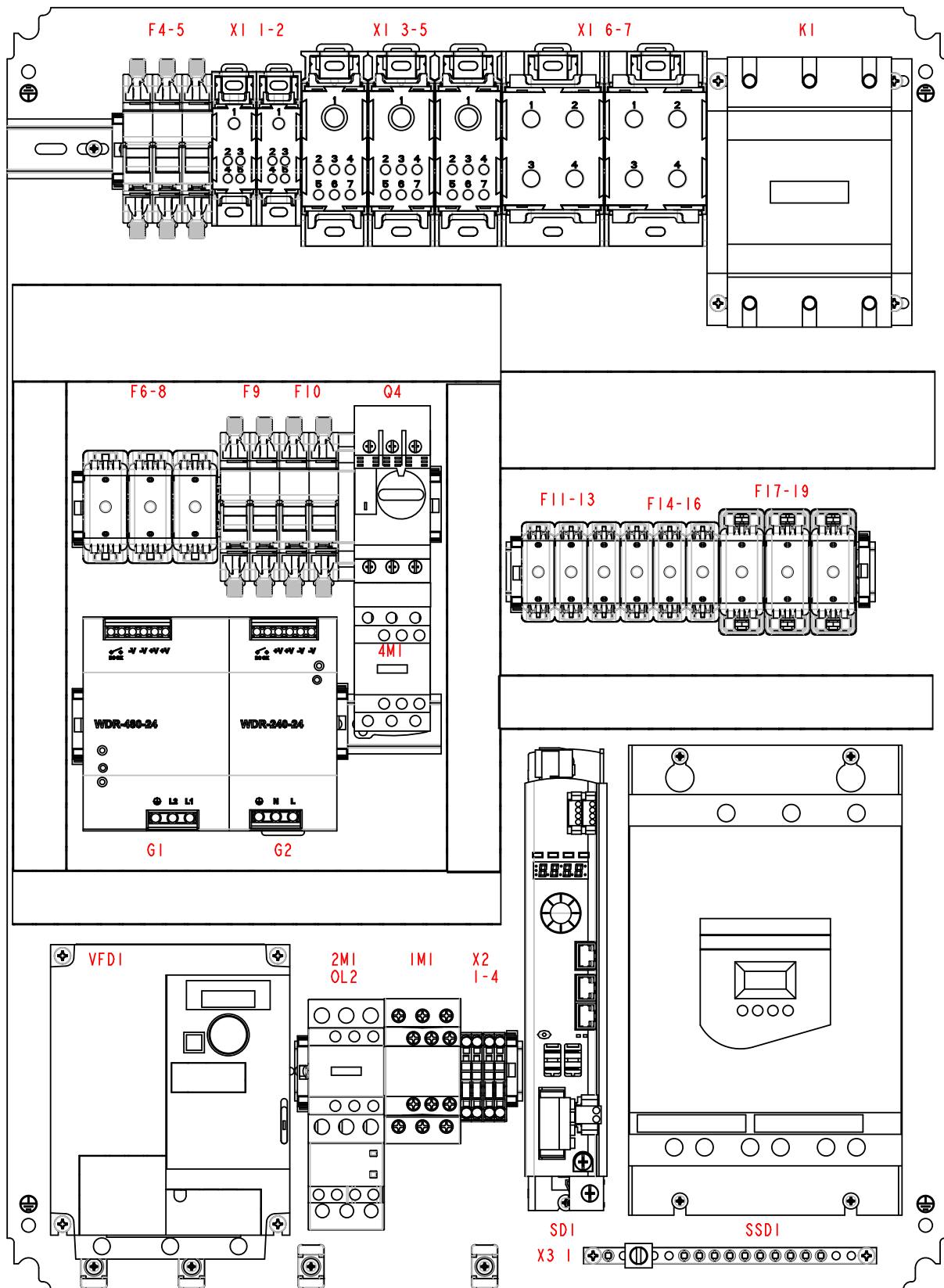



Wood-Mizer®

Project Description: WM4500 Bed Extension Full

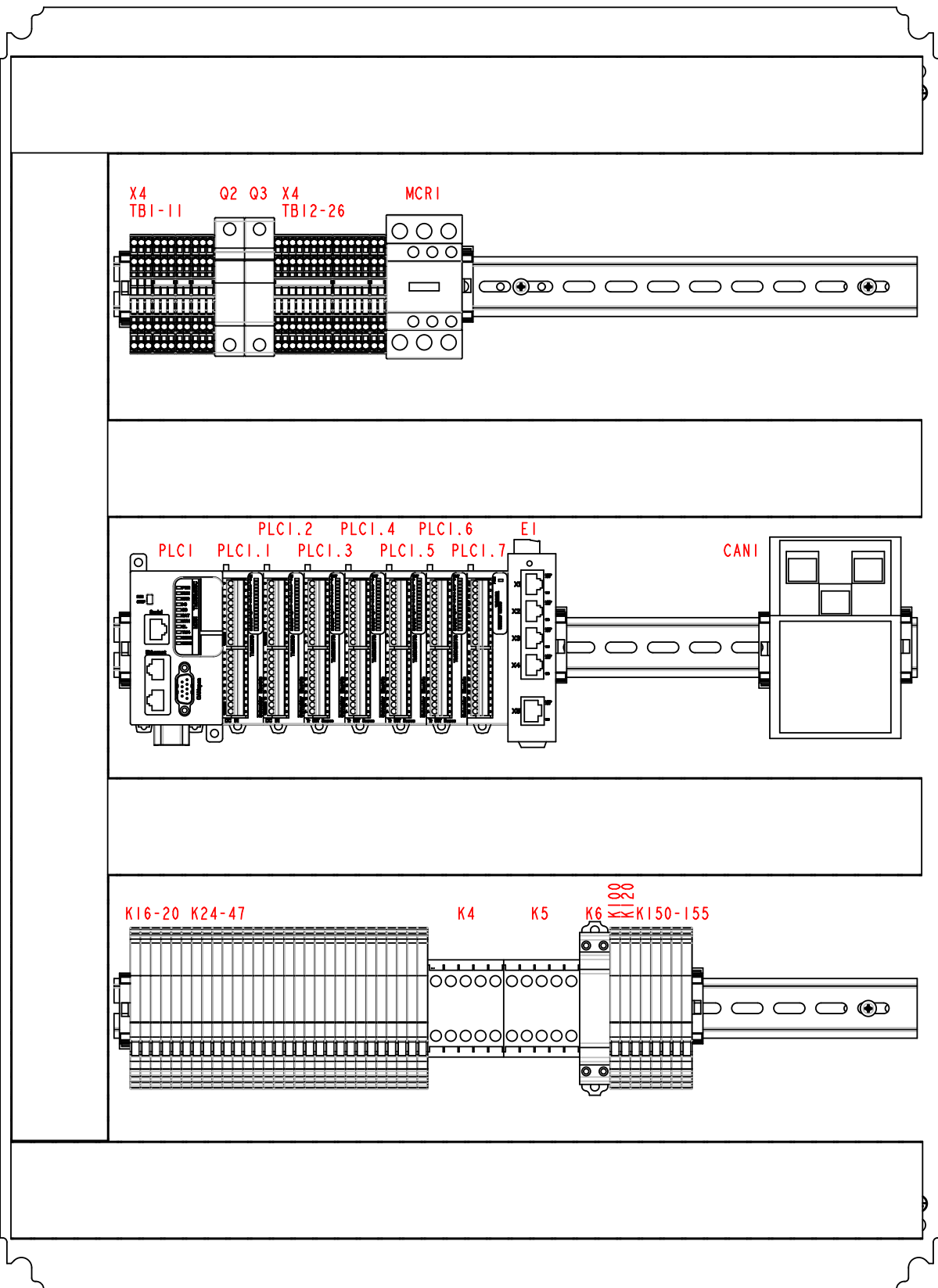
Revision:	A3.05	Pg Desc: Main Control High Voltage Layout	
Mounting Location:	+Docs	Type: Panel layout	
Prev. pg:	F2	Page:	F3
		Next pg:	F4
		Total Pgs:	93

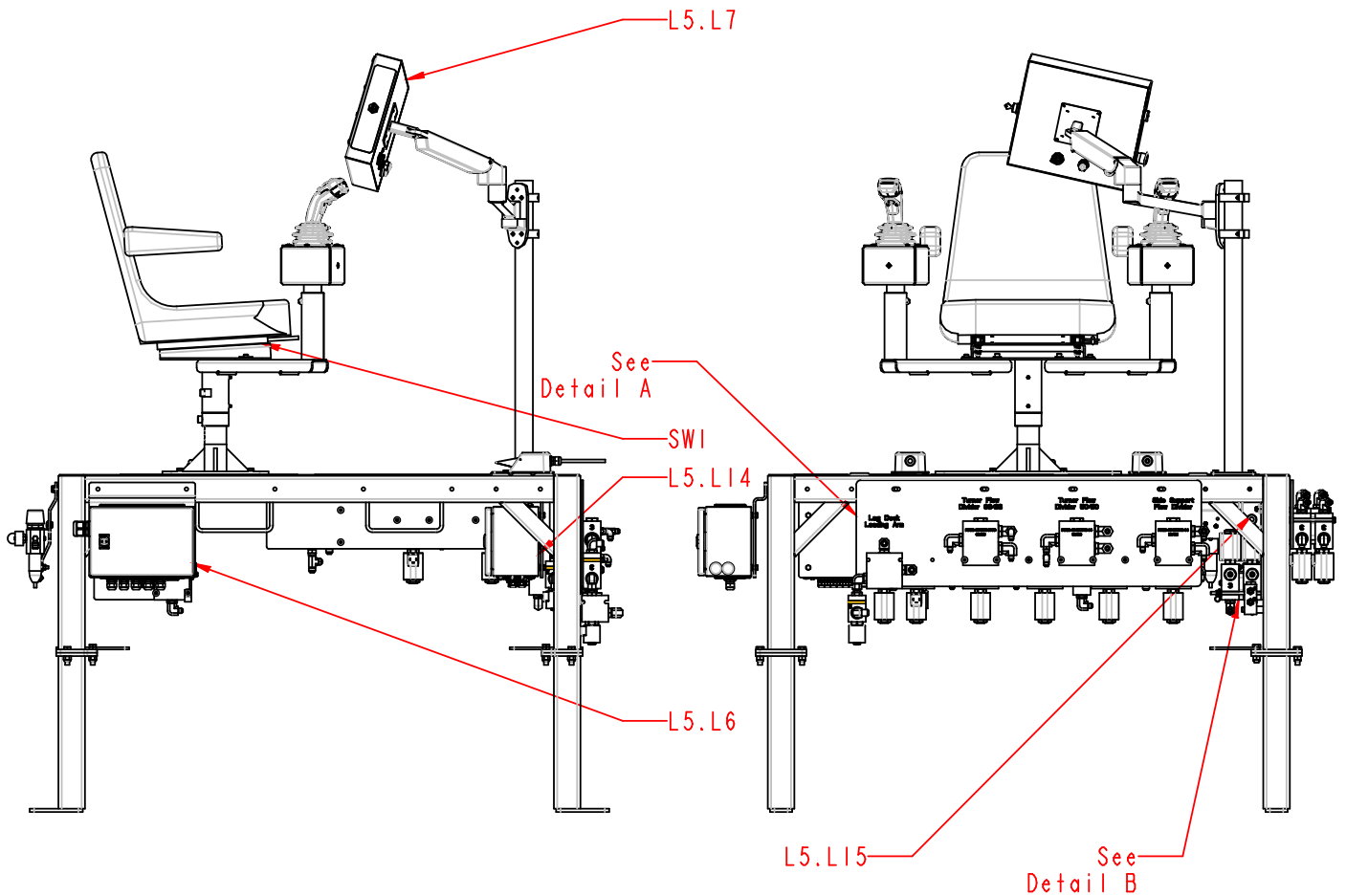
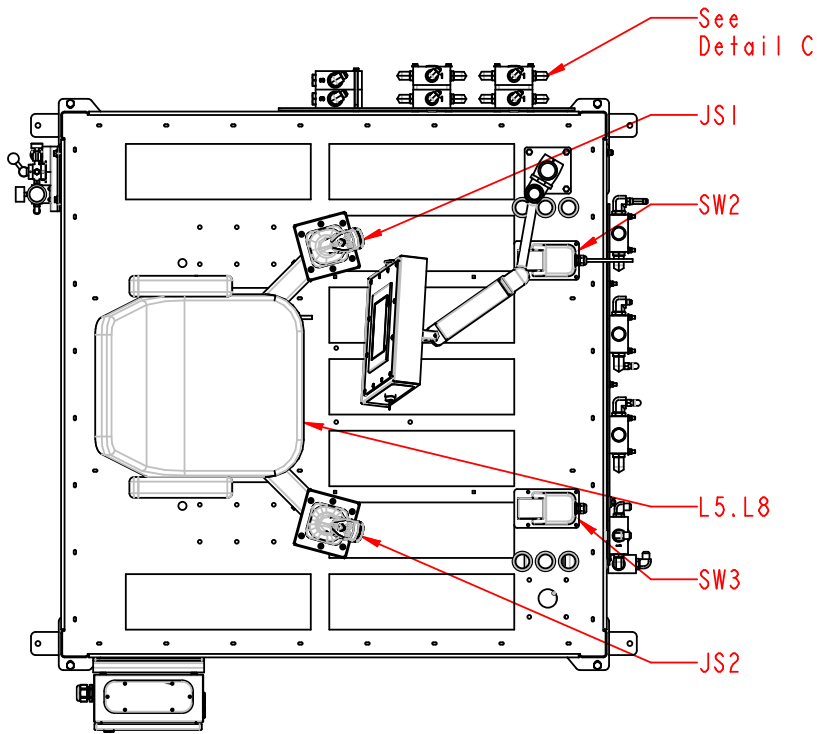



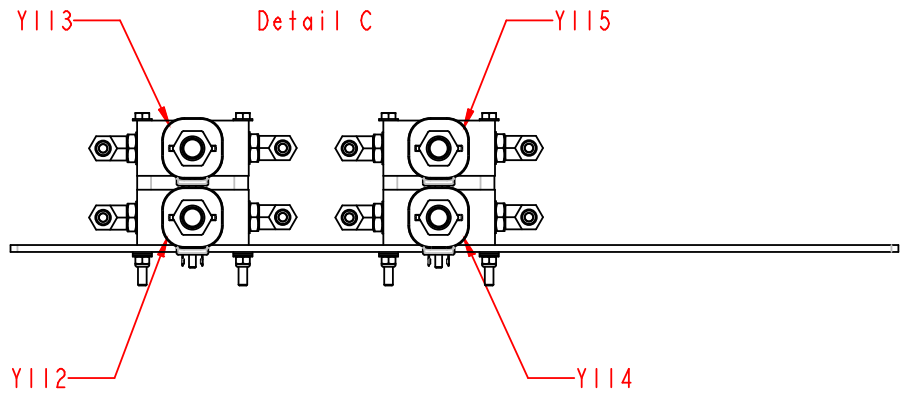
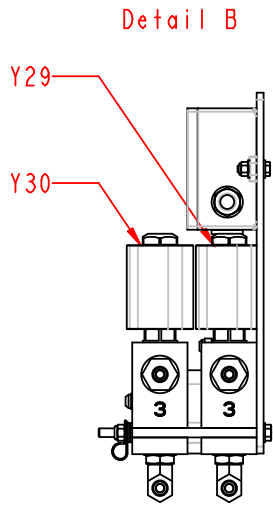
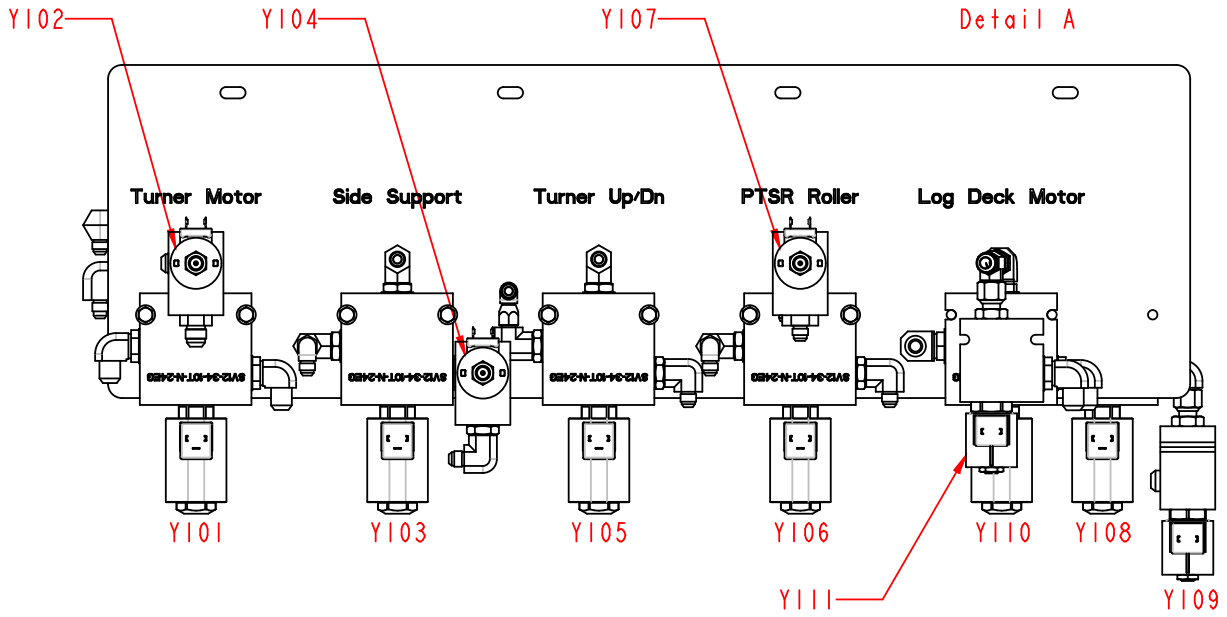

		Wood-Mizer®	
Project Description: WM4500 Bed Extension Full			
Revision: A3.05		Pg Desc: Operator Ctl Layout	
Mounting Location: +Docs		Type: Panel layout	
Prev. pg: F4	Page: F5	Next pg: F6	Total Pgs: 93

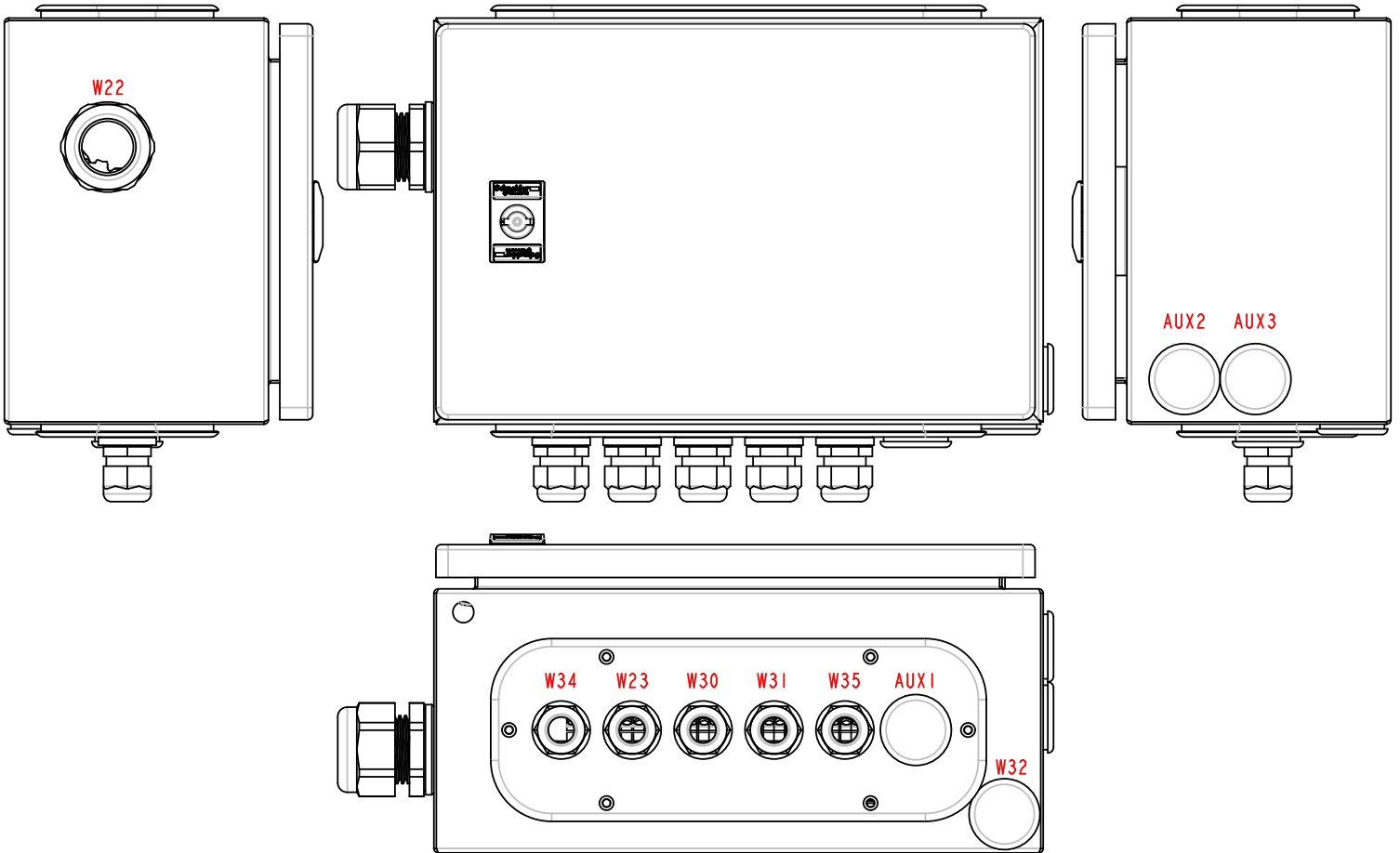
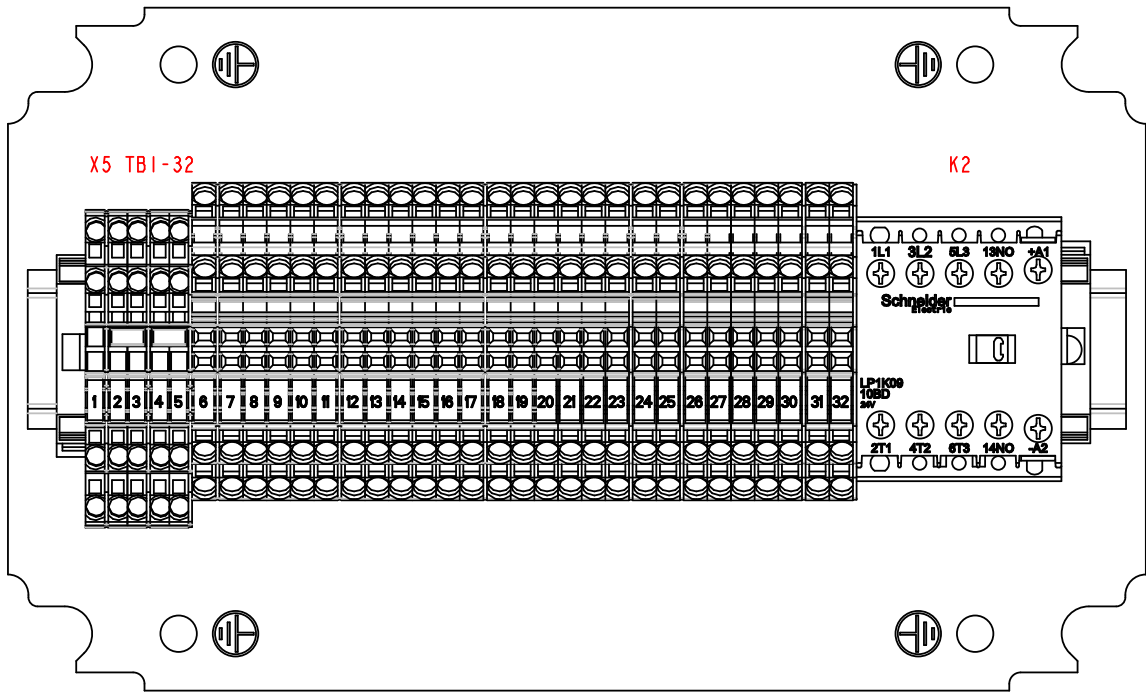

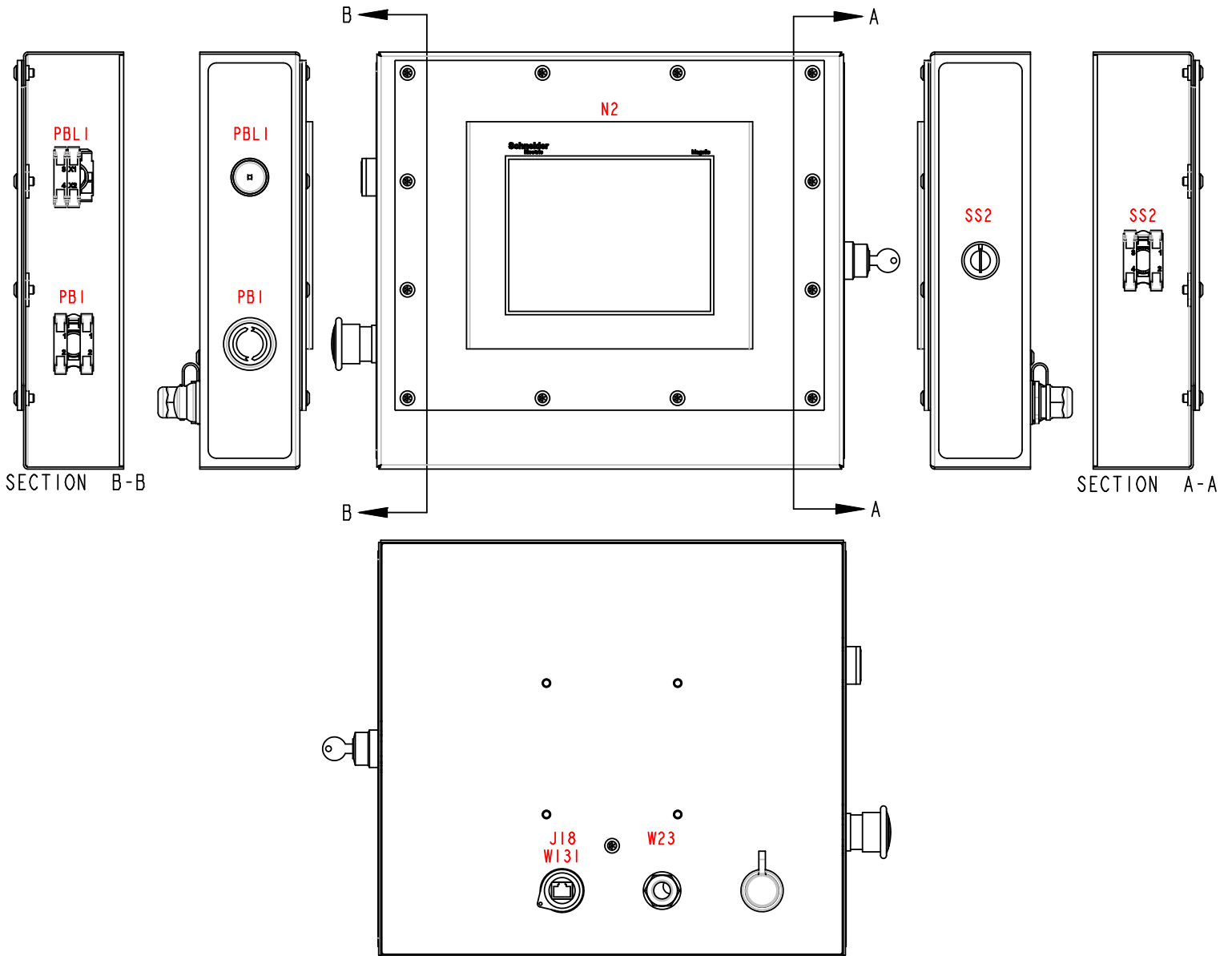

 Wood-Mizer®	
Project Description: WM4500 Bed Extension Full	
Revision: A3.05	Pg Desc: Operator Ctl Junction Layout
Mounting Location: +Docs	
Prev. pg: F6	Type: Panel layout
Page: F7	Next pg: F8
Total Pgs: 93	



 Wood-Mizer®	
Project Description: WM4500 Bed Extension Full	
Revision: A3.05	Pg Desc: Operator Ctl HMI Layout
Mounting Location: +Docs	
Type: Panel layout	
Prev. pg: F7	Page: F8
Next pg: F9	Total Pgs: 93

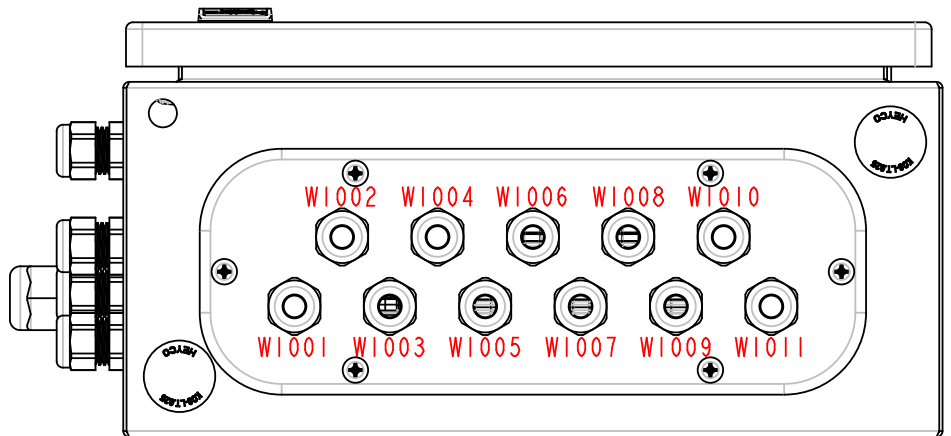
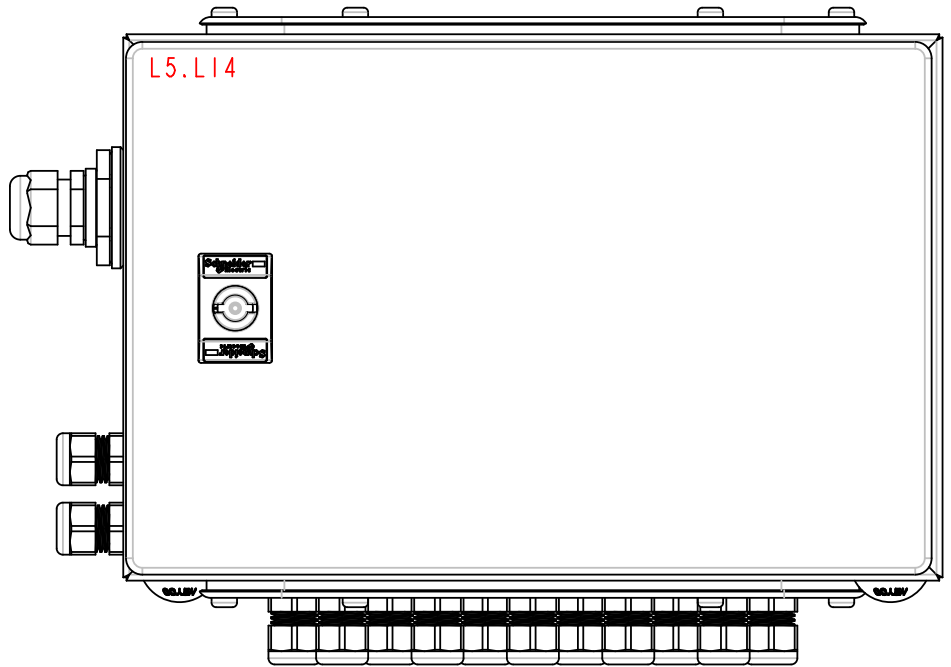
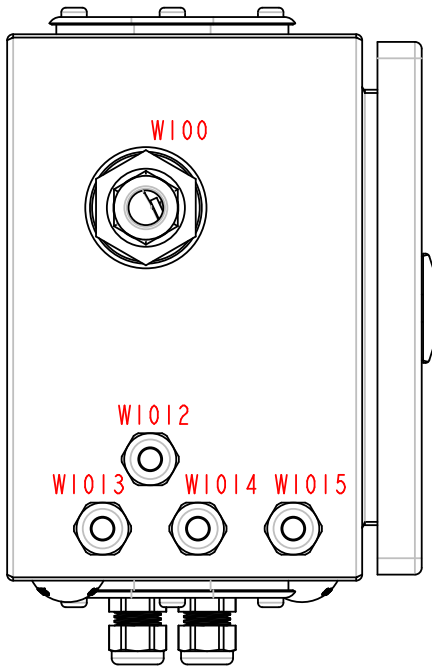
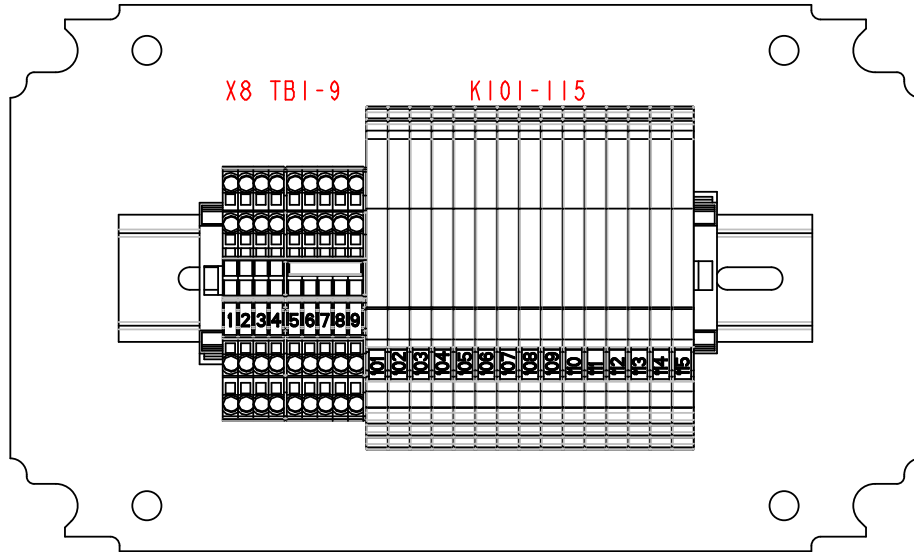

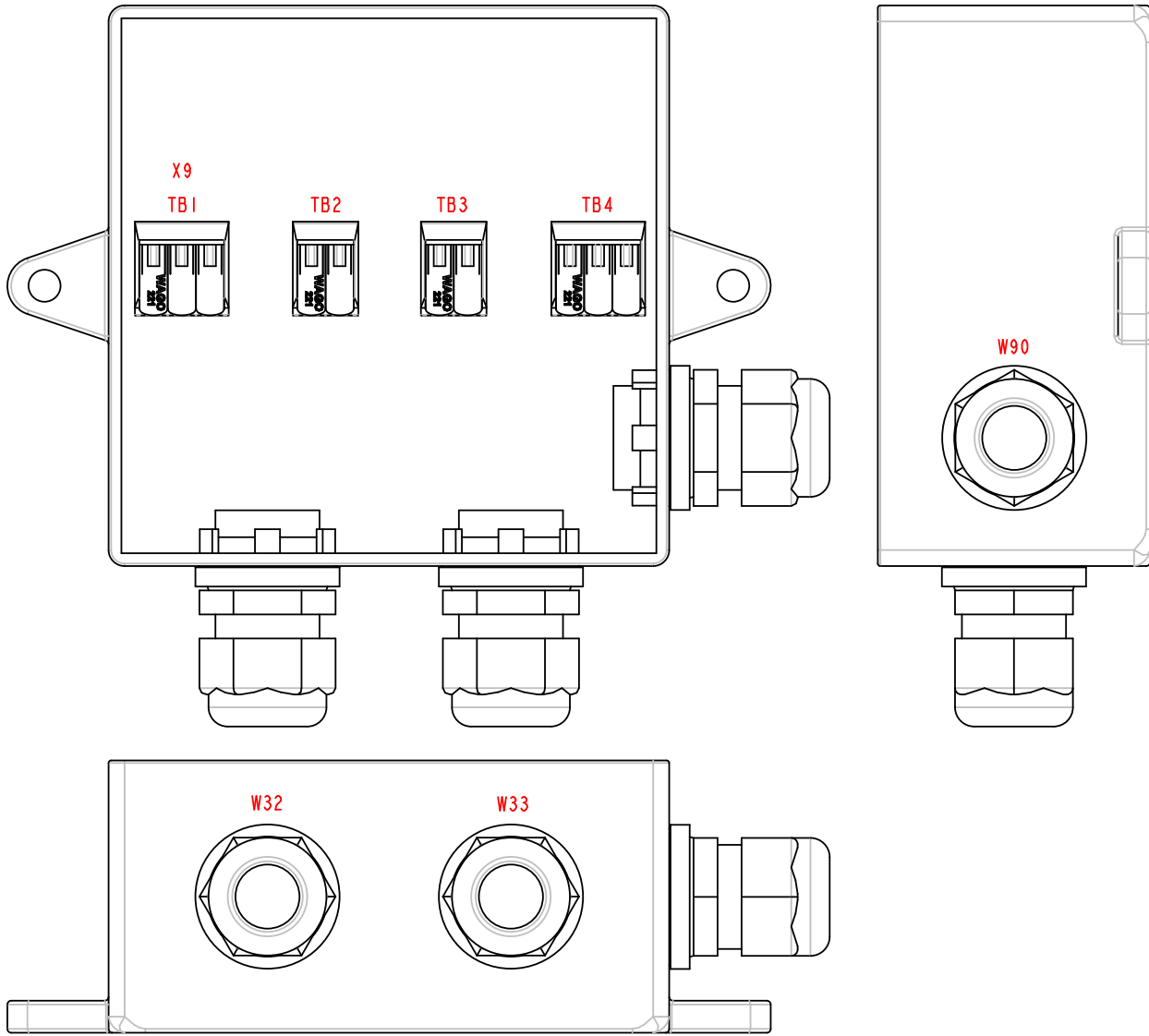

Wood-Mizer®

Project Description: WM4500 Bed Extension Full

Revision:	A3.05	Pg Desc: Operator Ctl Side Supports Layout	
Mounting Location:	+Docs	Type: Panel layout	
Prev. pg:	F9	Page:	F10
		Next pg:	F11
		Total Pgs:	93

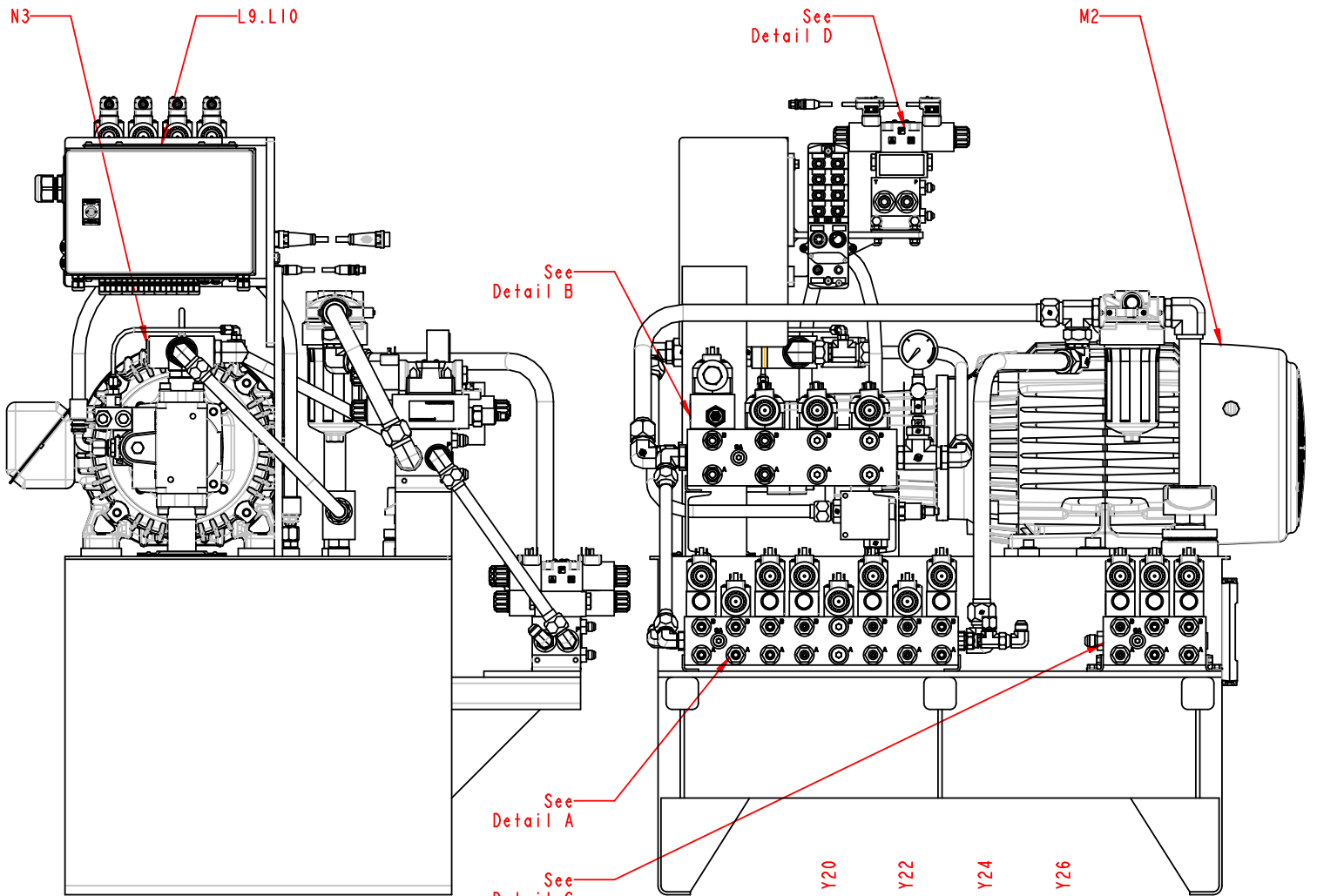

Detail A

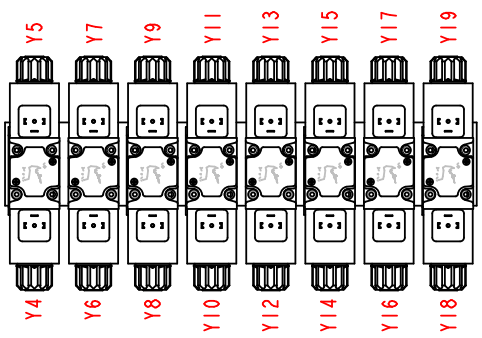

Detail B

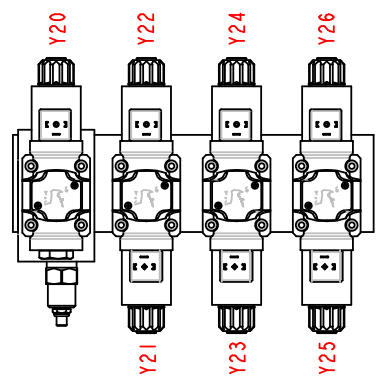

Detail C

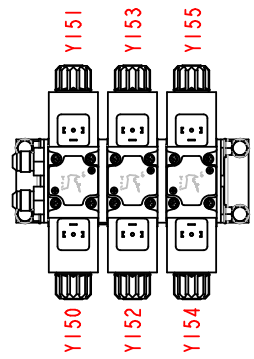

Detail D

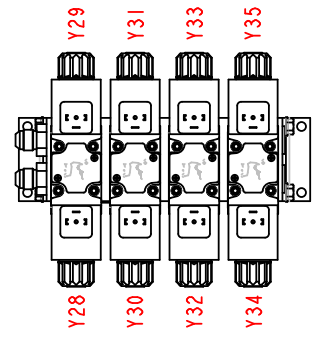

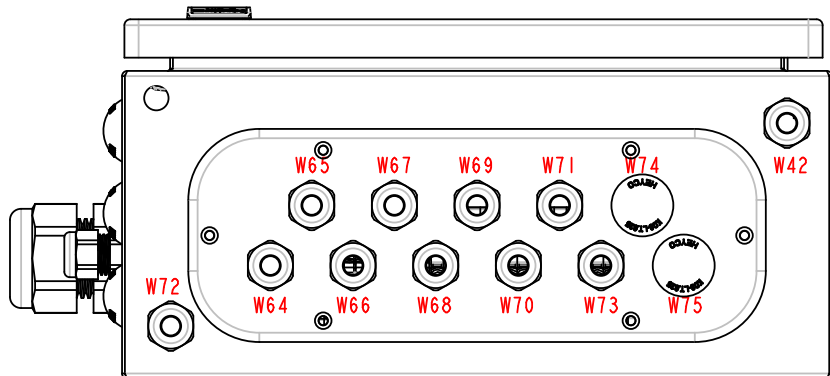
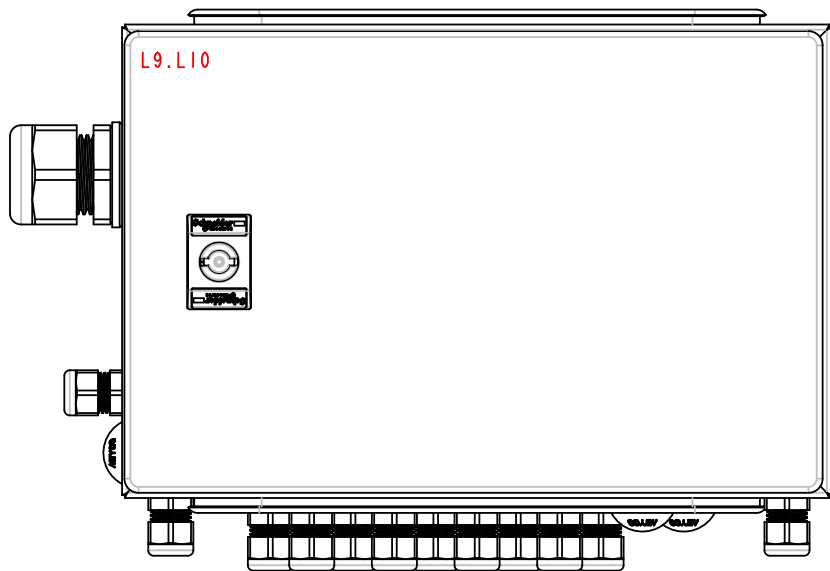
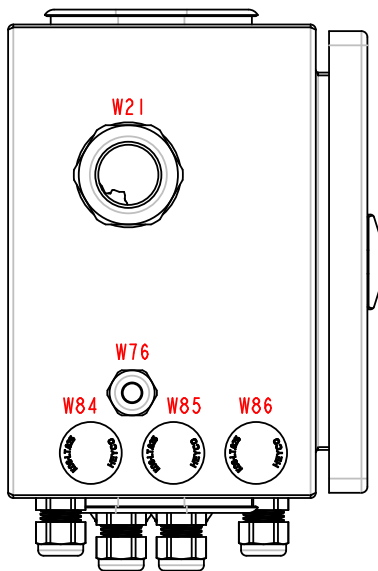
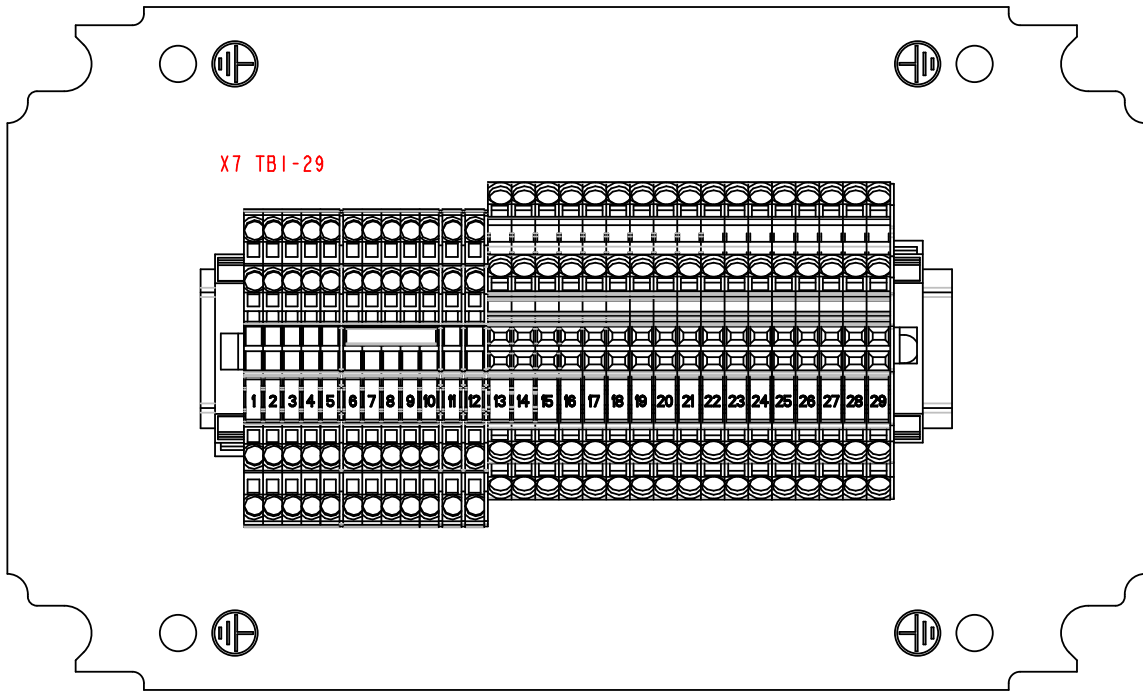

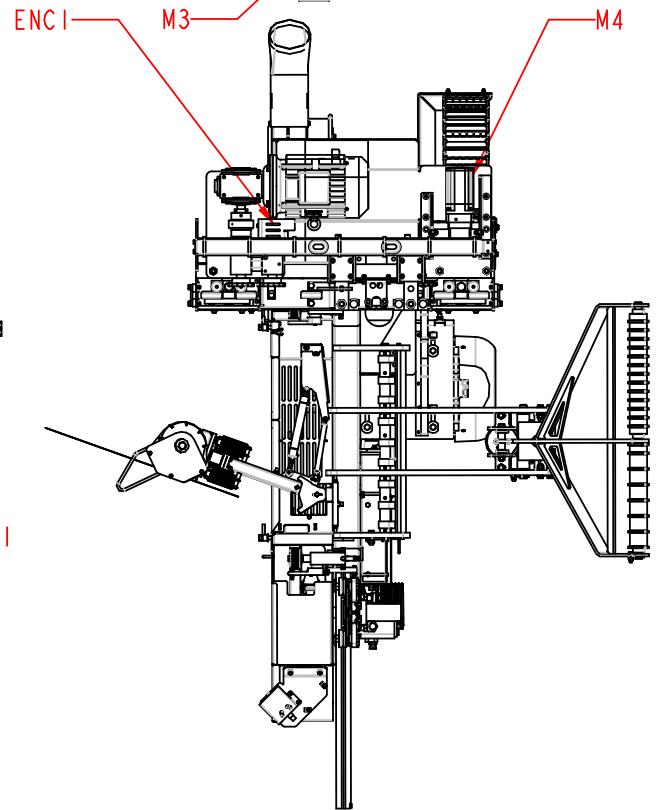
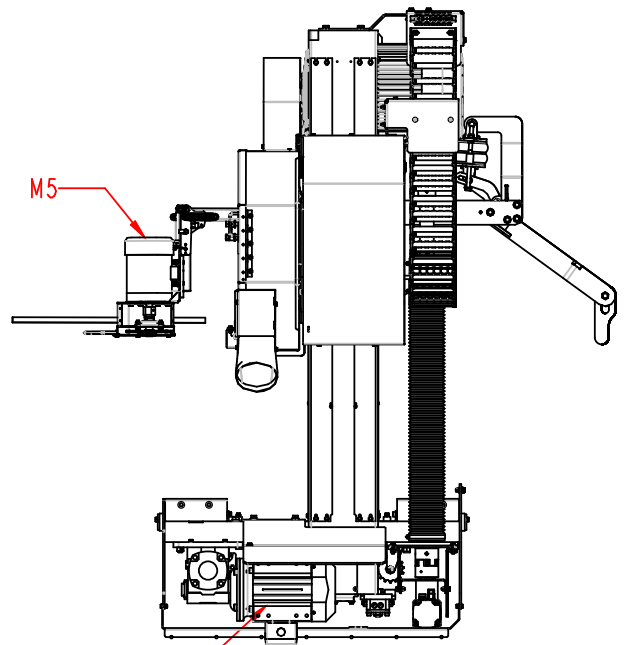
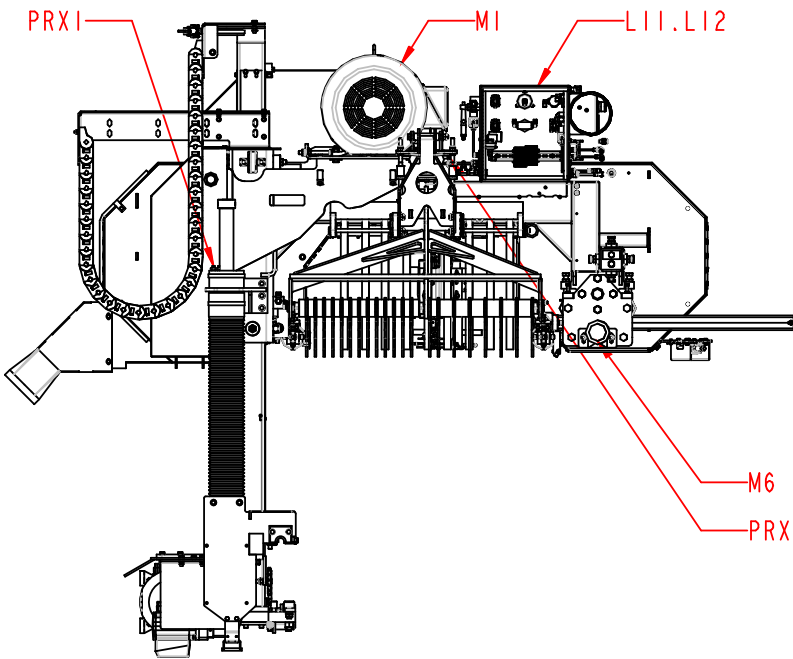
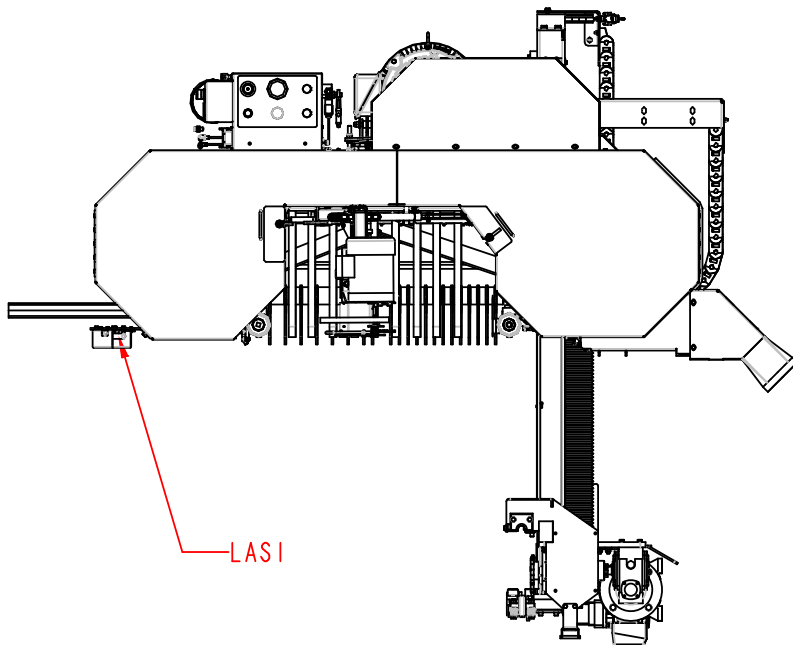

		Wood-Mizer®	
Project Description: WM4500 Bed Extension Full			
Revision: A3.05		Pg Desc: Head Control Layout	
Mounting Location: +Docs		Type: Panel layout	
Prev. pg: F12	Page: F13	Next pg: F14	Total Pgs: 93

Y3 (Inside Cover)
Debarker In Solenoid

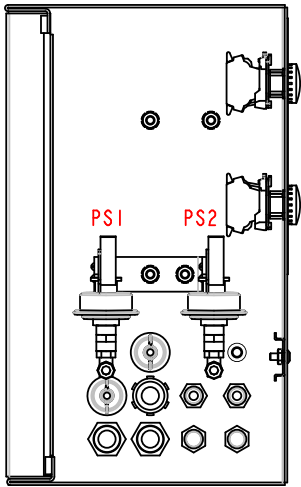
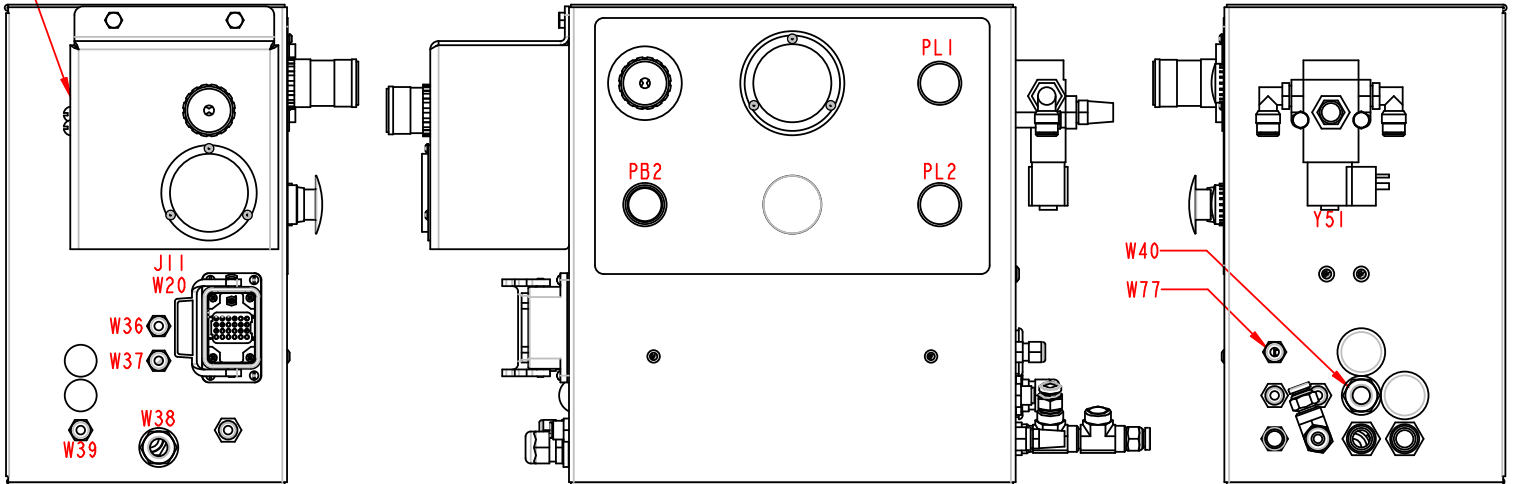

SECTION B-B

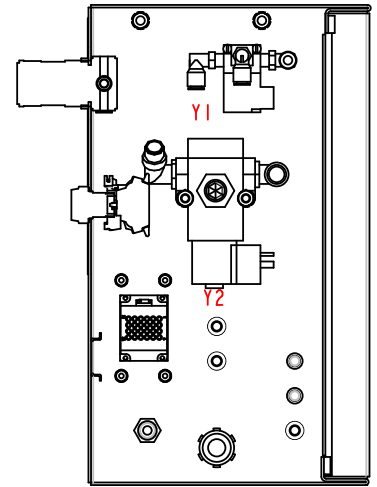
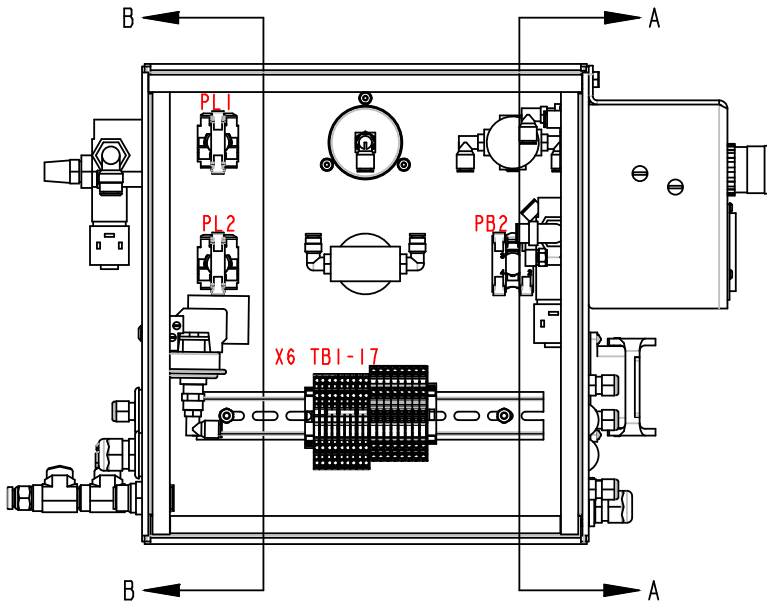

SECTION A-A

Revision History

Date	Revision	Revision Record	Drawn By	Checked By
8/6/18	A1.00	Release to production	JRF	SDC
4/26/19	A2.00	Added Pull Down Clamp Functions	JRF	SDC
12/6/19	A3.00	Full Bed Extension	JRF	SDC
2/4/20	A3.03	Dual Toe Board Cylinders	JRF	SDC

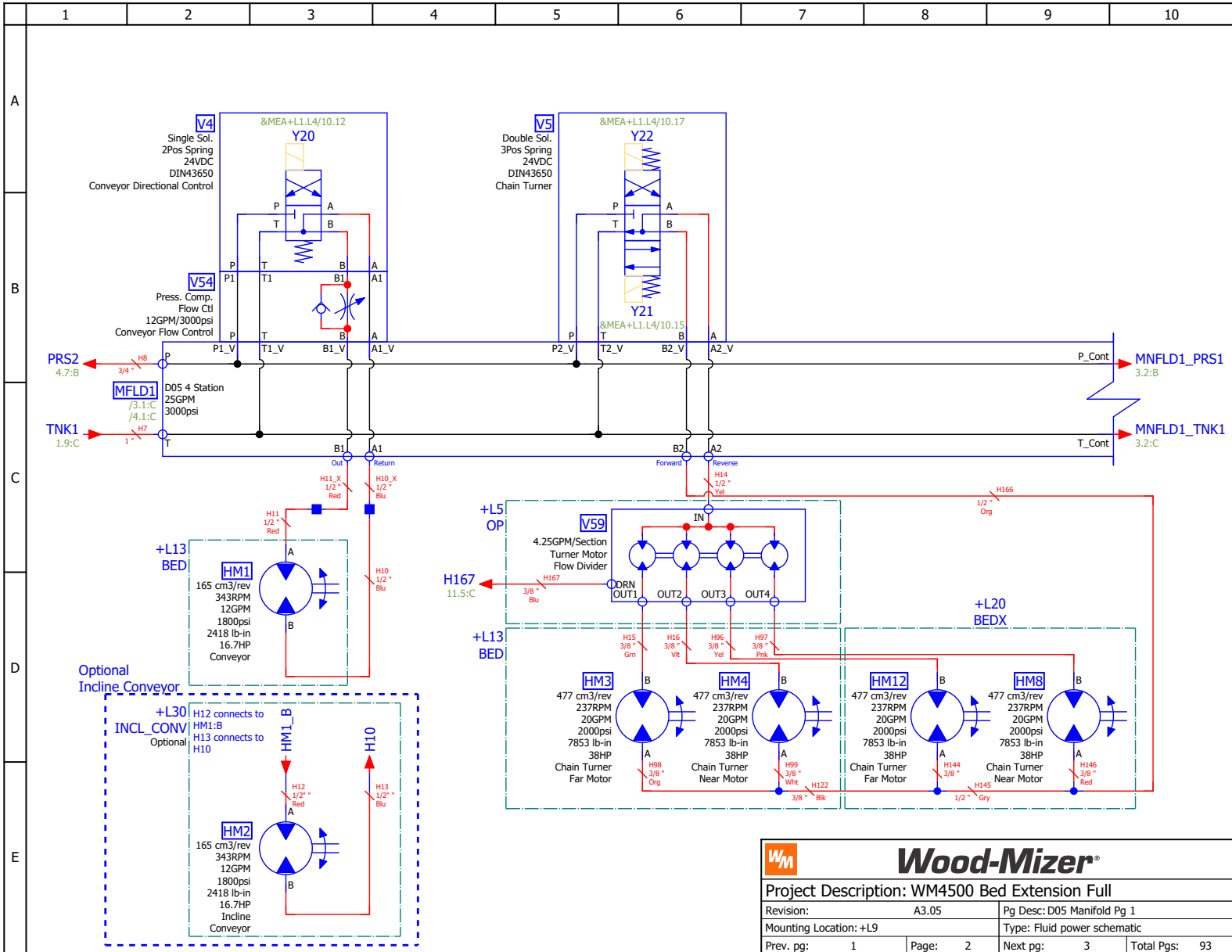

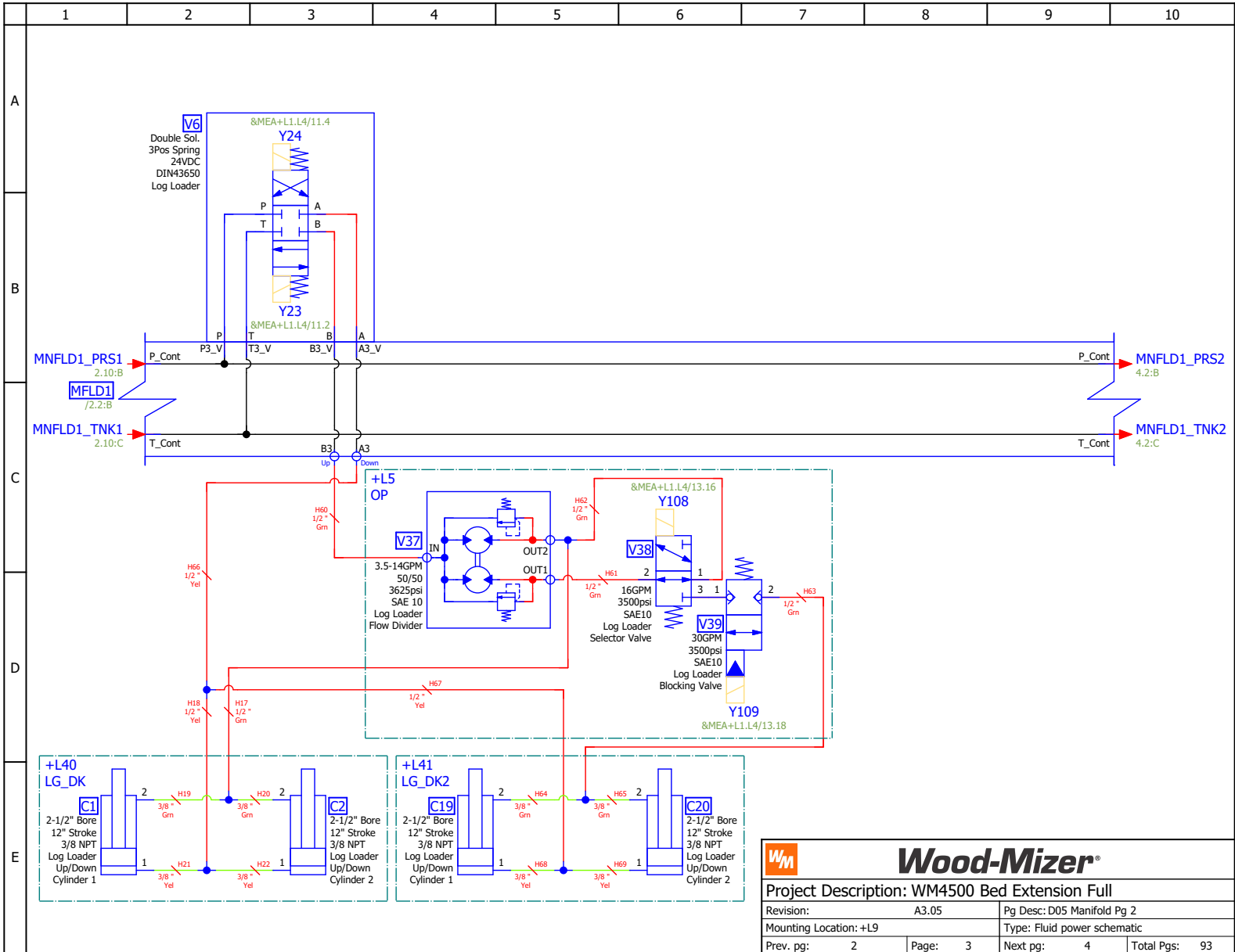

Project Description: WM4500 Bed Extension Full

Revision:	A3.05	Pg Desc: D05 Manifold Pg 2
Mounting Location: +L9		Type: Fluid power schematic
Prev. pg: 2	Page: 3	Next pg: 4
		Total Pgs: 93

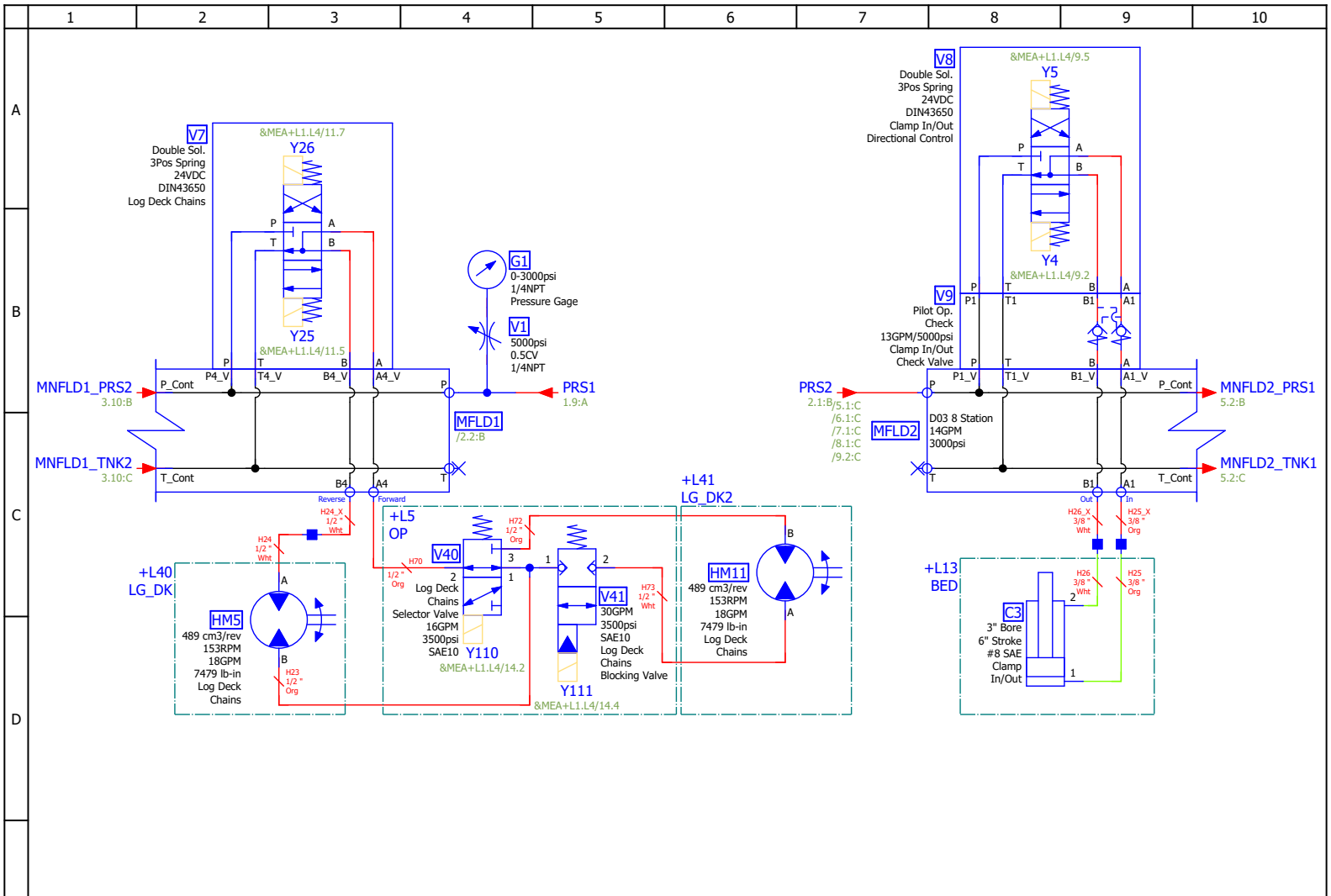

 Wood-Mizer®			
Project Description: WM4500 Bed Extension Full			
Revision:	A3.05	Pg Desc:	D05 Manifold Pg 3
Mounting Location:	+L9	Type:	Fluid power schematic
Prev. pg:	3	Page:	4
		Next pg:	5
		Total Pgs:	93

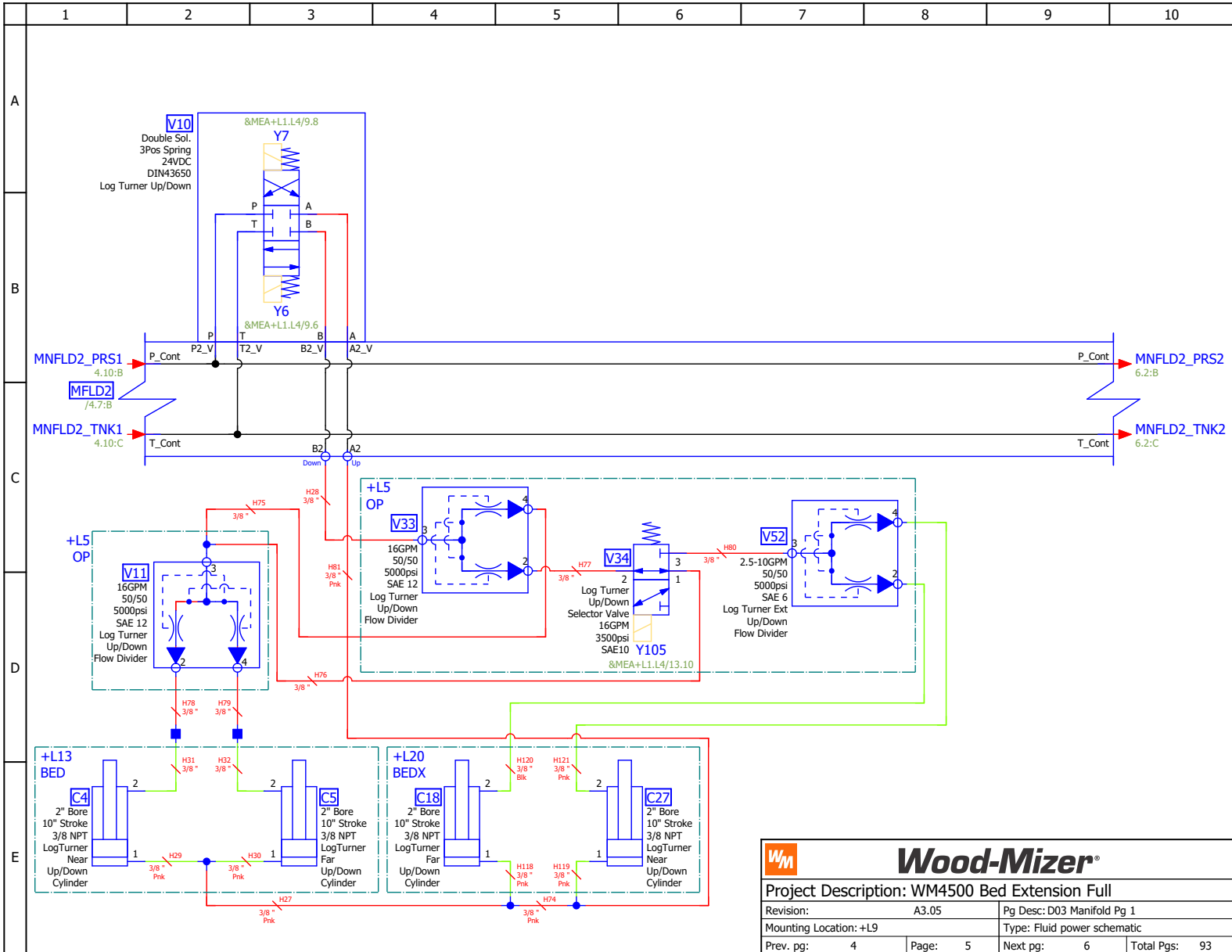

Wood-Mizer®			
Project Description: WM4500 Bed Extension Full			
Revision:	A3.05	Pg Desc:	D03 Manifold Pg 1
Mounting Location:	+L9	Type:	Fluid power schematic
Prev. pg:	4	Page:	5
		Next pg:	6
		Total Pgs:	93

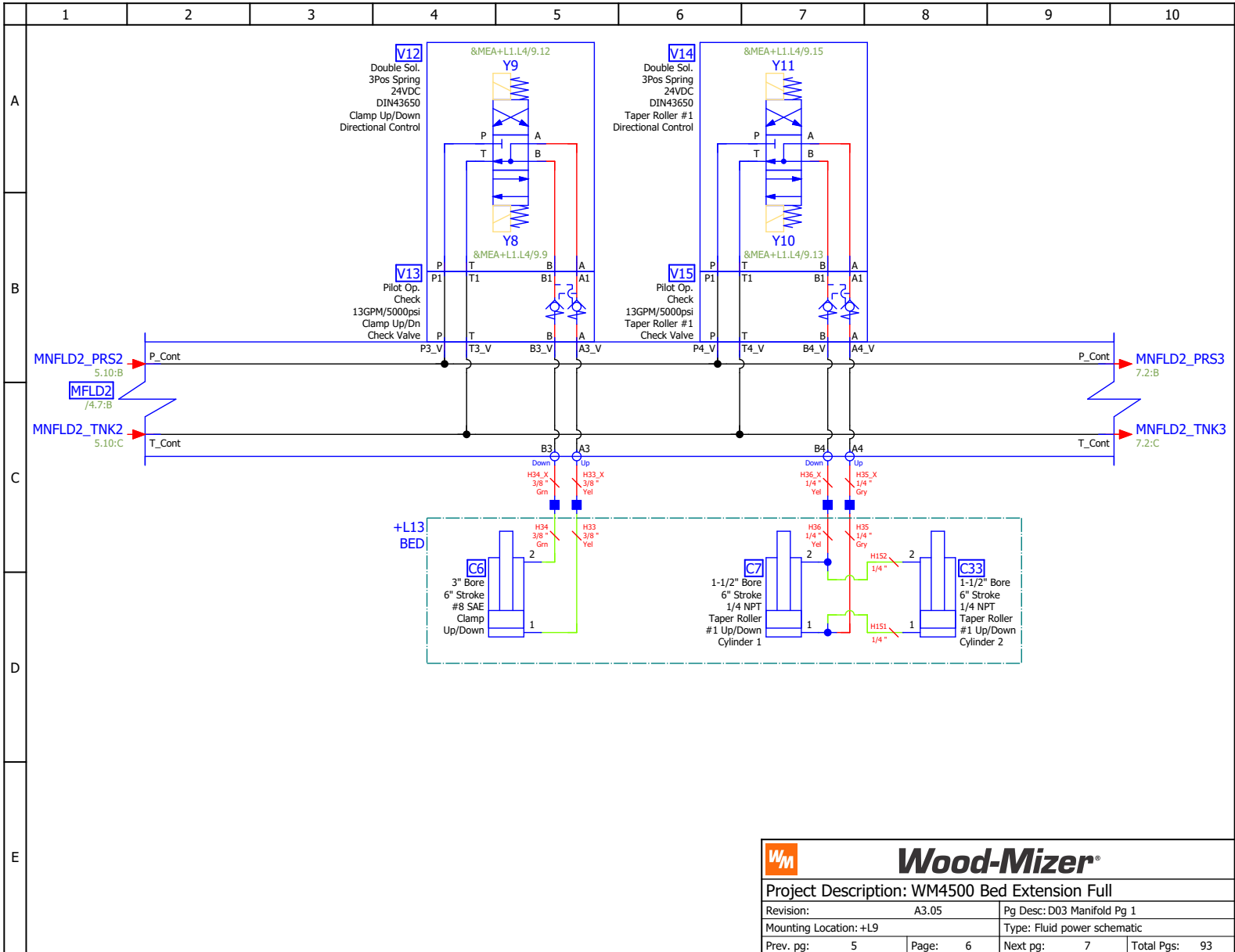

Wood-Mizer®

Project Description: WM4500 Bed Extension Full

Revision: A3.05	Pg Desc: D03 Manifold Pg 1
Mounting Location: +L9	Type: Fluid power schematic
Prev. pg: 5	Page: 6
Next pg: 7	Total Pgs: 93

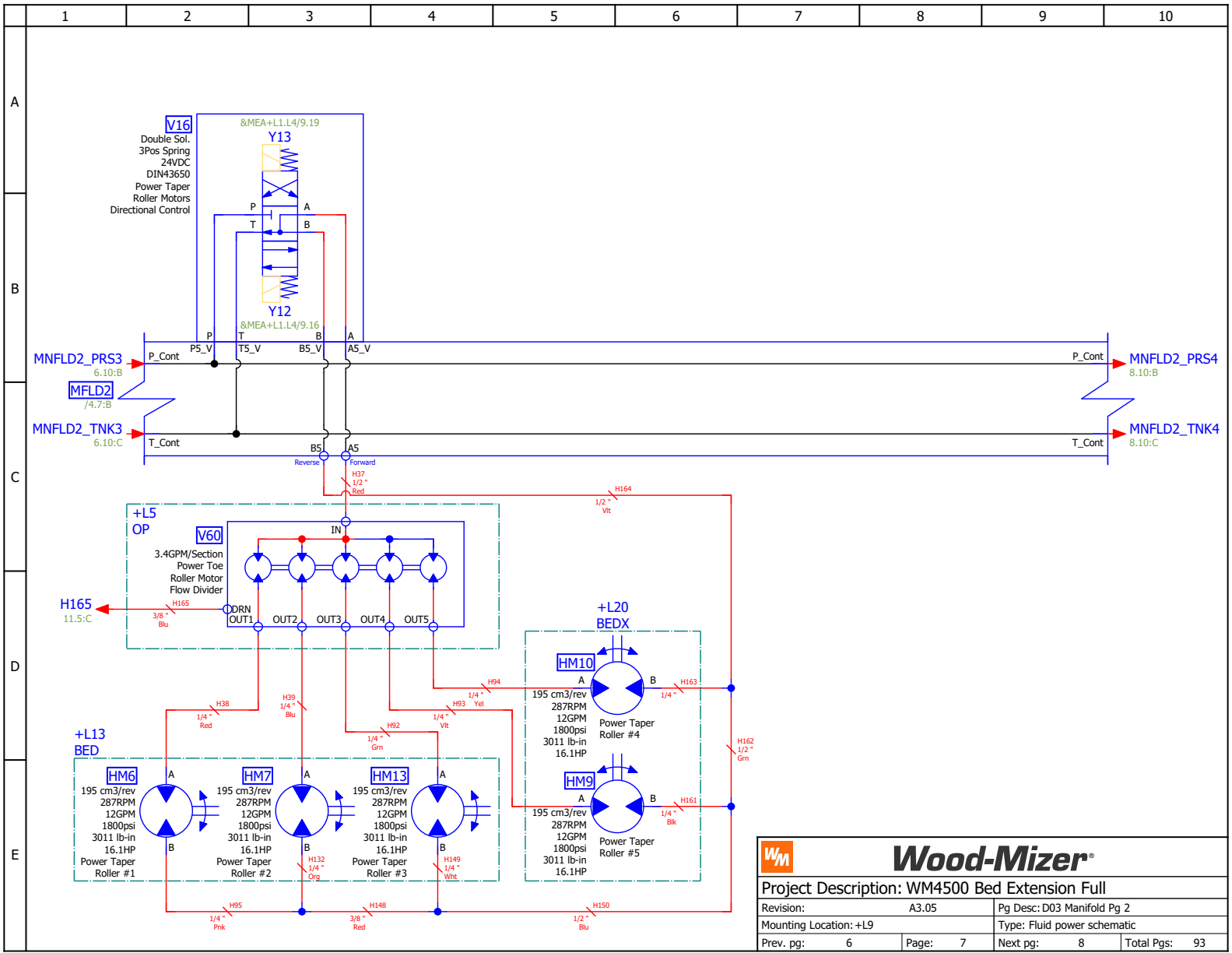

Wood-Mizer®			
Project Description: WM4500 Bed Extension Full			
Revision:	A3.05	Pg Desc:	D03 Manifold Pg 2
Mounting Location:	+L9	Type:	Fluid power schematic
Prev. pg:	6	Page:	7
Next pg:	8	Total Pgs:	93

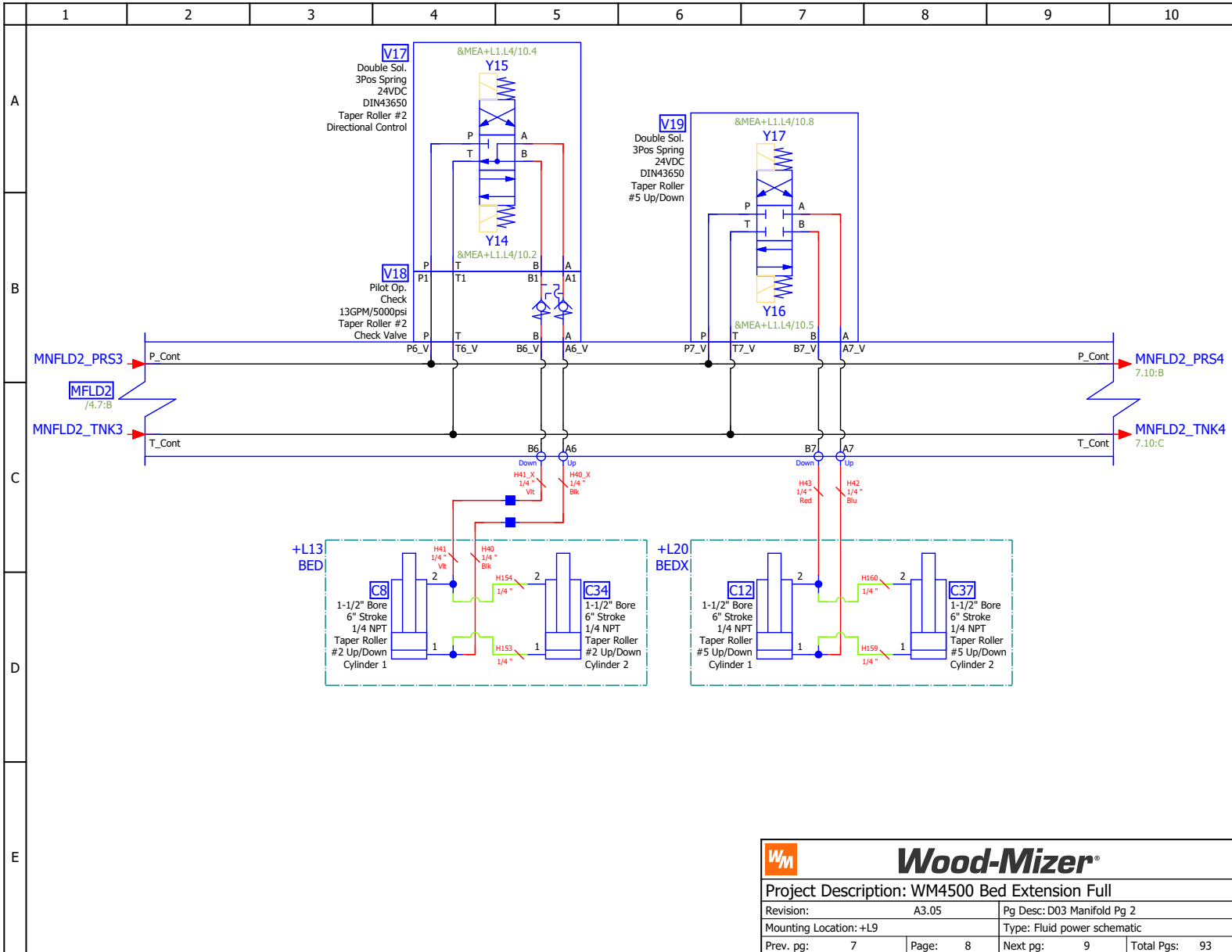

Wood-Mizer®

Project Description: WM4500 Bed Extension Full

Revision:	A3.05	Pg Desc: D03 Manifold Pg 2
Mounting Location: +L9		Type: Fluid power schematic
Prev. pg:	7	Page: 8
		Next pg: 9
		Total Pgs: 93

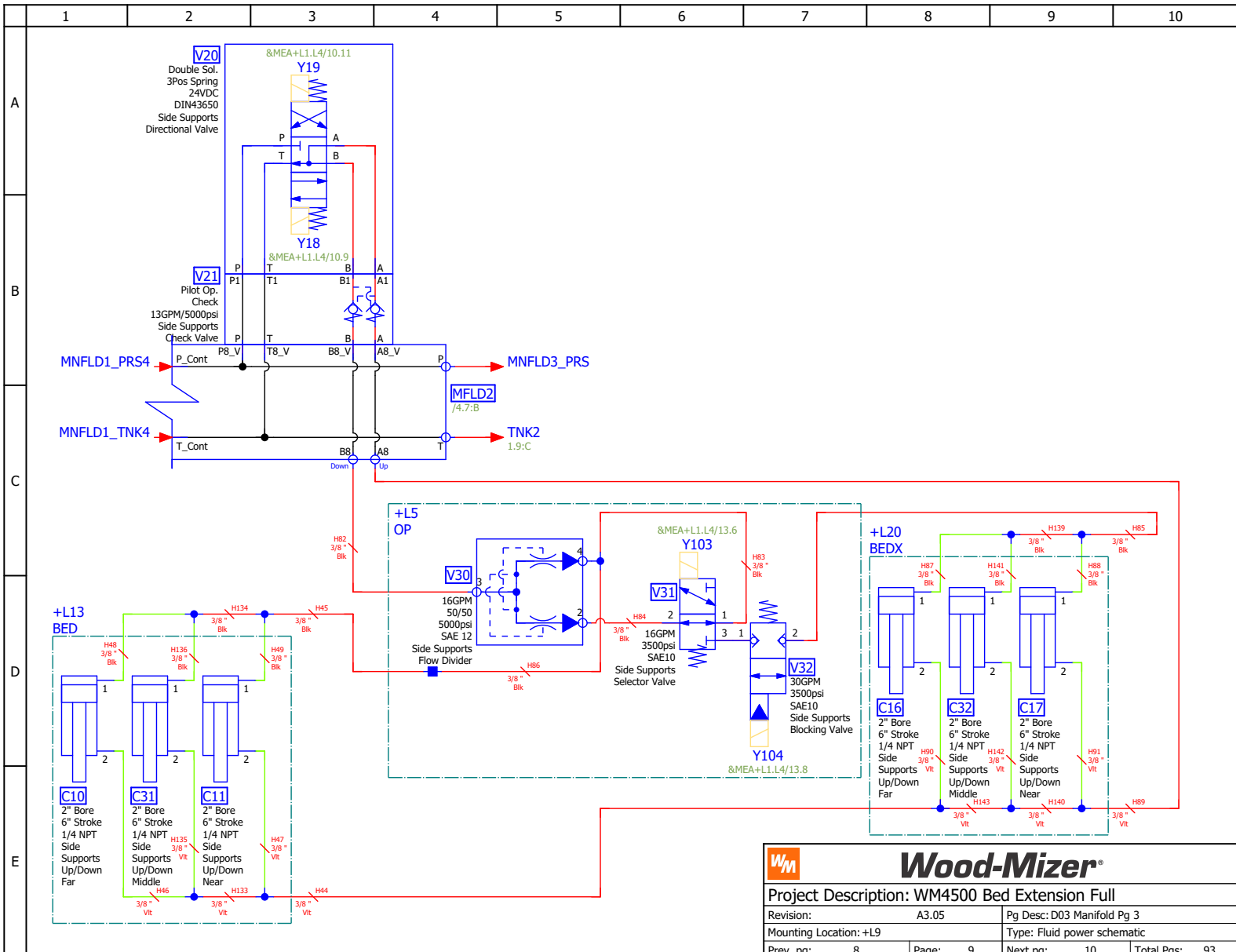

		Wood-Mizer®	
		Project Description: WM4500 Bed Extension Full	
Revision:	A3.05	Pg Desc:	D03 Manifold Pg 3
Mounting Location:	+L9	Type:	Fluid power schematic
Prev. pg:	8	Page:	9
		Next pg:	10
		Total Pgs:	93

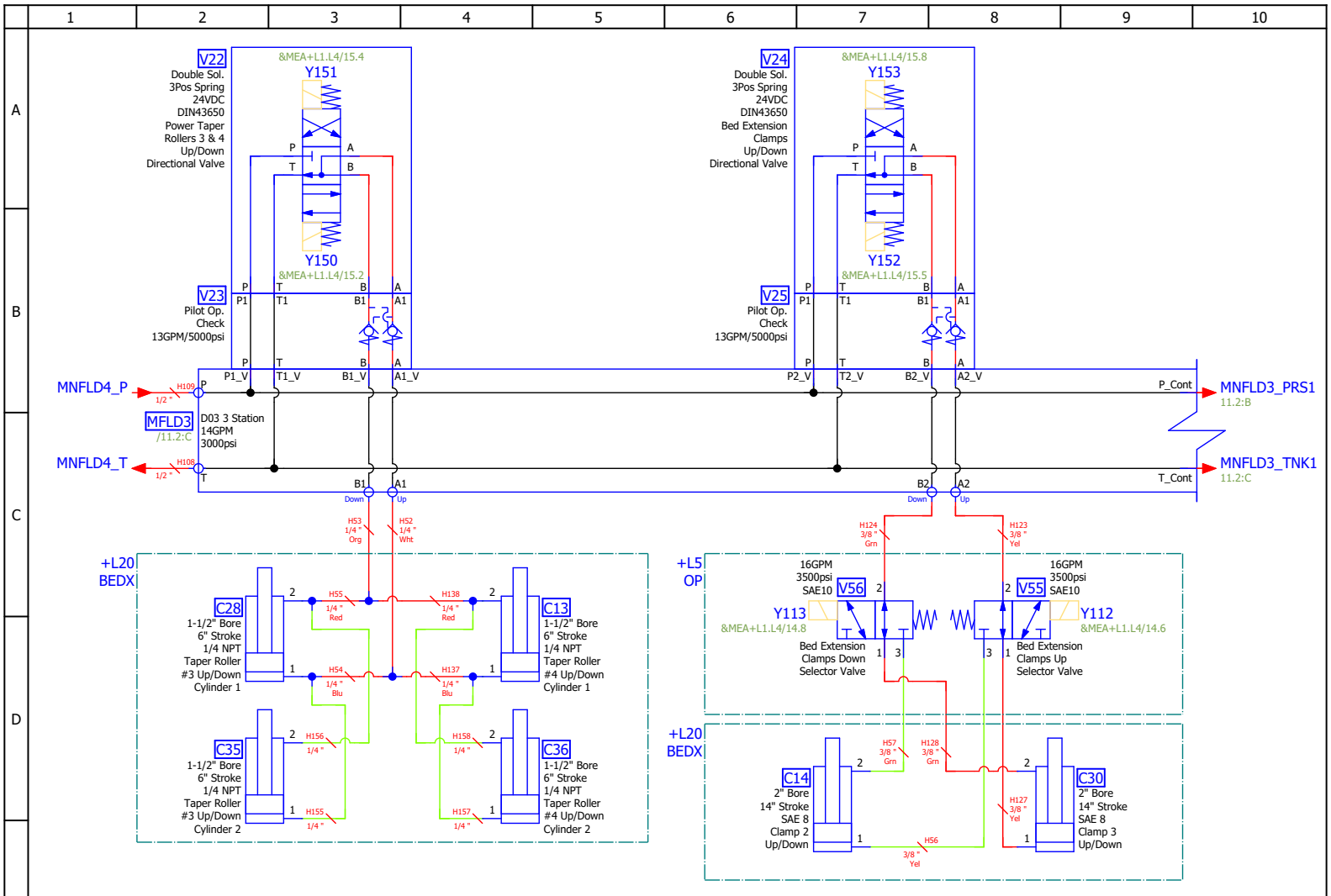

Wood-Mizer®			
Project Description: WM4500 Bed Extension Full			
Revision:	A3.05	Pg Desc: Bed Extension Manifold Pg 1	
Mounting Location:	+L9	Type: Fluid power schematic	
Prev. pg:	9	Page:	10
		Next pg:	11
		Total Pgs: 93	

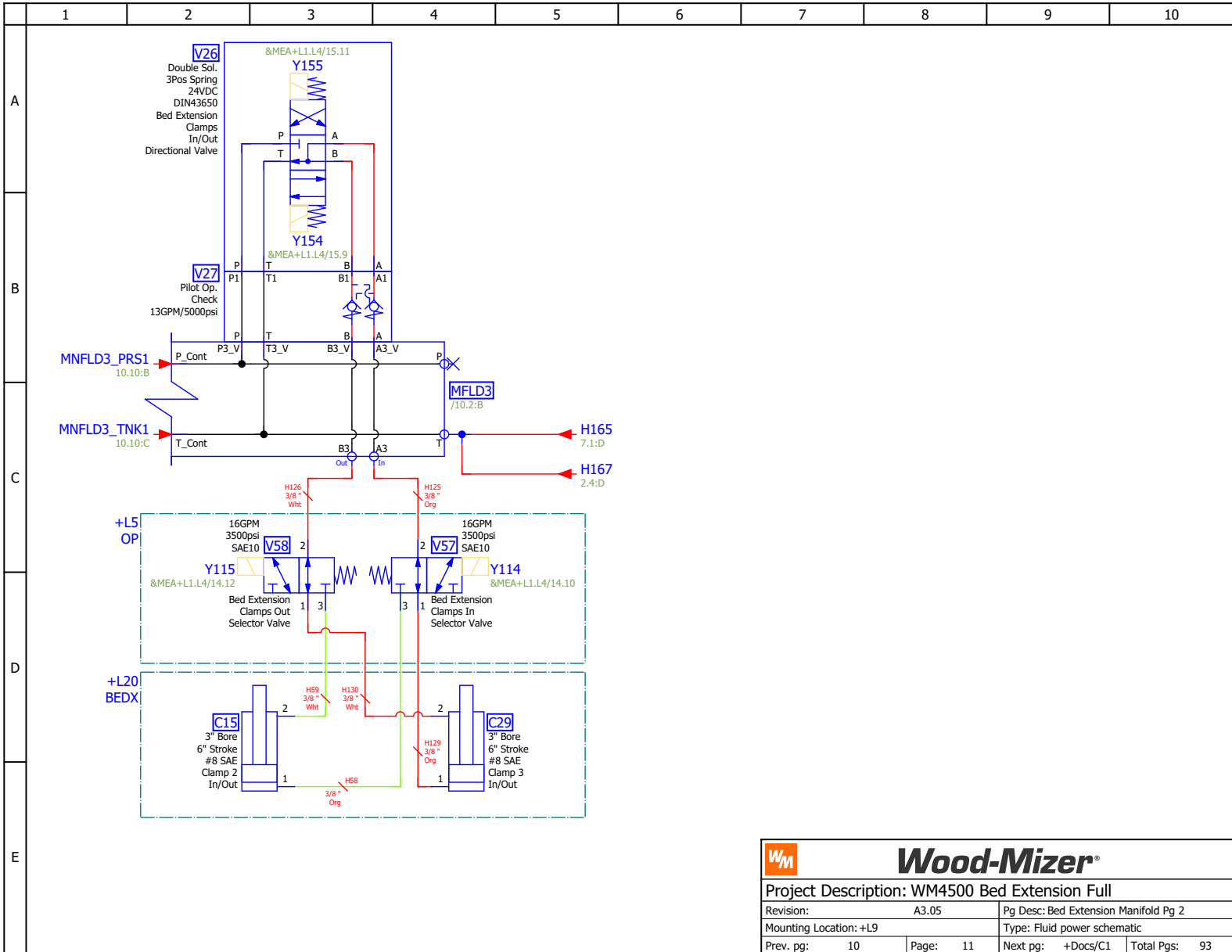

Wood-Mizer®

Project Description: WM4500 Bed Extension Full

Revision: A3.05 Pg Desc: Bed Extension Manifold Pg 2

Mounting Location: +L9 Type: Fluid power schematic

Prev. pg: 10 Page: 11 Next pg: +Docs/C1 Total Pgs: 93

Device Tag/Parts List

WM_PARTS_LIST_Fluid-Manual

Device tag	Function	Wood-Mizer Part Number	Wood-Mizer Description		Qty.	X-Ref
C1	Log Loader Up/Down Cylinder 1	050105	Cylinder, 2-1/2 Bore x 12x221/4		1	+L9/3.302:AE
C1	=	P12955	Seal Kit, 2 1/2x8 Hydraulic Cylinder	Replacement Seals	1	+L9/3.302:AE
C2	Log Loader Up/Down Cylinder 2	050105	Cylinder, 2-1/2 Bore x 12x221/4		1	+L9/3.303:AE
C2	=	P12955	Seal Kit, 2 1/2x8 Hydraulic Cylinder	Replacement Seals	1	+L9/3.303:AE
C3	Clamp In/Out	062700	Cylinder, Hyd 3x6		1	+L9/4.409:AC
C4	LogTurner Near Up/Down Cylinder	034267	Cylinder, 2x10 Rod End Welded 16"		1	+L9/5.502:AE
C4	=	003814	Seal Kit, Hyd Cylinder, 2x10 (034267)	Replacement Seals	1	+L9/5.502:AE
C5	LogTurner Far Up/Down Cylinder	034267	Cylinder, 2x10 Rod End Welded 16"		1	+L9/5.503:AE
C5	=	003814	Seal Kit, Hyd Cylinder, 2x10 (034267)	Replacement Seals	1	+L9/5.503:AE
C6	Clamp Up/Down	062700	Cylinder, Hyd 3x6		1	+L9/6.605:AC
C7	Taper Roller #1 Up/Down Cylinder 1	014482	Cylinder, 1 1/2x6 Rod End In Line Ports		1	+L9/6.607:AC
C7	=	014547	Seal Kit, 1 1/2x6 Hyd Cyl	Replacement Seals	1	+L9/6.607:AC
C8	Taper Roller #2 Up/Down Cylinder 1	014482	Cylinder, 1 1/2x6 Rod End In Line Ports		1	+L9/8.804:AD
C8	=	014547	Seal Kit, 1 1/2x6 Hyd Cyl	Replacement Seals	1	+L9/8.804:AD
C10	Side Supports Up/Down Far	035625	Cylinder, 2x6, 1/4 NPT Port		1	+L9/9.901:AD
C10	=	003812	Seal Kit, Hyd Cylinder, 2x6 (035625)	Replacement Seals	1	+L9/9.901:AD
C11	Side Supports Up/Down Near	035625	Cylinder, 2x6, 1/4 NPT Port		1	+L9/9.903:AD
C11	=	003812	Seal Kit, Hyd Cylinder, 2x6 (035625)	Replacement Seals	1	+L9/9.903:AD
C12	Taper Roller #5 Up/Down Cylinder 1	014482	Cylinder, 1 1/2x6 Rod End In Line Ports		1	+L9/8.807:AD
C12	=	014547	Seal Kit, 1 1/2x6 Hyd Cyl	Replacement Seals	1	+L9/8.807:AD
C13	Taper Roller #4 Up/Down Cylinder 1	014482	Cylinder, 1 1/2x6 Rod End In Line Ports		1	+L9/10.1004:AC
C13	=	014547	Seal Kit, 1 1/2x6 Hyd Cyl		1	+L9/10.1004:AC
C14	Clamp 2 Up/Down	062701	Cylinder, Hyd 2x14		1	+L9/10.1007:AD
C15	Clamp 2 In/Out	062700	Cylinder, Hyd 3x6		1	+L9/11.1103:AD
C16	Side Supports Up/Down Far	035625	Cylinder, 2x6, 1/4 NPT Port		1	+L9/9.908:AD
C16	=	003812	Seal Kit, Hyd Cylinder, 2x6 (035625)	Replacement Seals	1	+L9/9.908:AD
C17	Side Supports Up/Down Near	035625	Cylinder, 2x6, 1/4 NPT Port		1	+L9/9.909:AD
C17	=	003812	Seal Kit, Hyd Cylinder, 2x6 (035625)	Replacement Seals	1	+L9/9.909:AD
C18	LogTurner Far Up/Down Cylinder	034267	Cylinder, 2x10 Rod End Welded 16"		1	+L9/5.505:AE
C18	=	003814	Seal Kit, Hyd Cylinder, 2x10 (034267)	Replacement Seals	1	+L9/5.505:AE
C19	Log Loader Up/Down Cylinder 1	050105	Cylinder, 2-1/2 Bore x 12x221/4		1	+L9/3.305:AE
C19	=	P12955	Seal Kit, 2 1/2x8 Hydraulic Cylinder	Replacement Seals	1	+L9/3.305:AE
C20	Log Loader Up/Down Cylinder 2	050105	Cylinder, 2-1/2 Bore x 12x221/4		1	+L9/3.306:AE
C20	=	P12955	Seal Kit, 2 1/2x8 Hydraulic Cylinder	Replacement Seals	1	+L9/3.306:AE
C27	LogTurner Near Up/Down Cylinder	034267	Cylinder, 2x10 Rod End Welded 16"		1	+L9/5.505:AE
C27	=	003814	Seal Kit, Hyd Cylinder, 2x10 (034267)	Replacement Seals	1	+L9/5.505:AE
C28	Taper Roller #3 Up/Down Cylinder 1	014482	Cylinder, 1 1/2x6 Rod End In Line Ports		1	+L9/10.1003:AC
C28	=	014547	Seal Kit, 1 1/2x6 Hyd Cyl		1	+L9/10.1003:AC
C29	Clamp 3 In/Out	062700	Cylinder, Hyd 3x6		1	+L9/11.1104:AD
C30	Clamp 3 Up/Down	062701	Cylinder, Hyd 2x14		1	+L9/10.1008:AD
C31	Side Supports Up/Down Middle	035625	Cylinder, 2x6, 1/4 NPT Port		1	+L9/9.902:AD
C31	=	003812	Seal Kit, Hyd Cylinder, 2x6 (035625)	Replacement Seals	1	+L9/9.902:AD
C32	=	035625	Cylinder, 2x6, 1/4 NPT Port		1	+L9/9.909:AD
C32	=	003812	Seal Kit, Hyd Cylinder, 2x6 (035625)	Replacement Seals	1	+L9/9.909:AD
C33	Taper Roller #1 Up/Down Cylinder 2	014482	Cylinder, 1 1/2x6 Rod End In Line Ports		1	+L9/6.608:AC
C33	=	014547	Seal Kit, 1 1/2x6 Hyd Cyl	Replacement Seals	1	+L9/6.608:AC

		Wood-Mizer®	
Project Description: WM4500 Bed Extension Full			
Revision:	A3.05	Pg Desc: Parts list - Bed Extension Full	
Mounting Location: +Docs		Type: Parts list	
Prev. pg:	+L9/11	Page:	C1
Next pg:		C2	Total Pgs: 93

Device Tag/Parts List

WM_PARTS_LIST_Fluid-Manual

Device tag	Function	Wood-Mizer Part Number	Wood-Mizer Description		Qty.	X-Ref
C34	Taper Roller #2 Up/Down Cylinder 2	014482	Cylinder, 1 1/2x6 Rod End In Line Ports		1	+L9/8.805:AD
C34	=	014547	Seal Kit, 1 1/2x6 Hyd Cyl	Replacement Seals	1	+L9/8.805:AD
C35	Taper Roller #3 Up/Down Cylinder 2	014482	Cylinder, 1 1/2x6 Rod End In Line Ports		1	+L9/10.1003:AD
C35	=	014547	Seal Kit, 1 1/2x6 Hyd Cyl		1	+L9/10.1003:AD
C36	Taper Roller #4 Up/Down Cylinder 2	014482	Cylinder, 1 1/2x6 Rod End In Line Ports		1	+L9/10.1004:AD
C36	=	014547	Seal Kit, 1 1/2x6 Hyd Cyl		1	+L9/10.1004:AD
C37	Taper Roller #5 Up/Down Cylinder 2	014482	Cylinder, 1 1/2x6 Rod End In Line Ports		1	+L9/8.808:AD
C37	=	014547	Seal Kit, 1 1/2x6 Hyd Cyl	Replacement Seals	1	+L9/8.808:AD
F1	Suction Strainer	078690	Strainer, Suction w/Bypass		1	+L9/1.104:AD
F2	Return Filter	078395	Filter, Hyd Cstr 35GPM 725psi wind SAE16		1	+L9/1.108:AC
F2	=	078341	Filter, Hyd. Element 10 Micron 25psi Byp	Replacement Element	1	+L9/1.108:AC
G1	Pressure Gage	068265	Gauge, Pressure VPG25N3KL		1	+L9/4.404:AB
HM1	Conveyor	P20206	Motor, Hydraulic, TB0165FP100AAAA		1	+L9/2.203:AD
HM1	=	061136	Kit, Hydraulic Motor Seal	Replacement Seals	1	+L9/2.203:AD
HM2	Incline Conveyor	P20206	Motor, Hydraulic, TB0165FP100AAAA		1	+L9/2.203:AE
HM2	=	061136	Kit, Hydraulic Motor Seal	Replacement Seals	1	+L9/2.203:AE
HM3	Chain Turner Far Motor	007331	Motor, Hydraulic, TG0475US0800AAFU		1	+L9/2.206:AD
HM4	Chain Turner Near Motor	007331	Motor, Hydraulic, TG0475US0800AAFU		1	+L9/2.207:AD
HM5	Log Deck Chains	056062	Motor, Hyd Log Deck		1	+L9/4.403:AD
HM6	Power Taper Roller #1	112587	Motor, Hydraulic, TB0195FP130AAAA		1	+L9/7.702:AE
HM6	=	061136	Kit, Hydraulic Motor Seal	Replacement Seals	1	+L9/7.702:AE
HM7	Power Taper Roller #2	112587	Motor, Hydraulic, TB0195FP130AAAA		1	+L9/7.703:AE
HM7	=	061136	Kit, Hydraulic Motor Seal	Replacement Seals	1	+L9/7.703:AE
HM8	Chain Turner Near Motor	007331	Motor, Hydraulic, TG0475US0800AAFU		1	+L9/2.209:AD
HM9	Power Taper Roller #5	112587	Motor, Hydraulic, TB0195FP130AAAA		1	+L9/7.706:AE
HM9	=	061136	Kit, Hydraulic Motor Seal	Replacement Seals	1	+L9/7.706:AE
HM10	Power Taper Roller #4	112587	Motor, Hydraulic, TB0195FP130AAAA		1	+L9/7.706:AD
HM10	=	061136	Kit, Hydraulic Motor Seal	Replacement Seals	1	+L9/7.706:AD
HM11	Log Deck Chains	056062	Motor, Hyd Log Deck		1	+L9/4.406:AC
HM12	Chain Turner Far Motor	007331	Motor, Hydraulic, TG0475US0800AAFU		1	+L9/2.208:AD
HM13	Power Taper Roller #3	112587	Motor, Hydraulic, TB0195FP130AAAA		1	+L9/7.704:AE
HM13	=	061136	Kit, Hydraulic Motor Seal	Replacement Seals	1	+L9/7.704:AE
MFLD1	D05 Power Unit Manifold	061190	D05, 4 Station Manifold		1	+L9/2.202:AB
MFLD1	=	078399	Plate, Cover D05 Valve	Covers For Optional Log Deck Valve Sections	2	+L9/2.202:AB
MFLD2	D03 Power Unit Manifold	061185	Manifold Shell Only, WM4000 AD03P082S		1	+L9/4.407:AB
MFLD3	D03 Bed Extension Manifold	078885	Manifold, D03 4 Station AI SAE		1	+L9/10.1002:AB
P1	Pump	078671	Pump, Hyd. 17GPM Piston Load Sense		1	+L9/1.102:AB
P1	=	078397	Adapter, C-Face Pump Mtr SAE B	Pump Mount	1	+L9/1.102:AB
P1	=	068252	Coupling, Pump		1	+L9/1.102:AB
P1	=	068253	Coupling, Motor		1	+L9/1.102:AB
P1	=	068254	Coupling, Insert		1	+L9/1.102:AB
V1	Pressure Gage Needle Valve	068264	Valve, Snubber MFG250BF		1	+L9/4.404:AB
V2	Proportional Valve	068273	Valve, Proportional PV72-30A	Complete Valve Assembly	1	+L9/1.103:AA
V2	=	061290	Block, Valve Body HF 7022350	Valve Body Only	1	+L9/1.103:AA
V2	=	078185	Valve, Proportional 15GPM PV72-30A	Valve Cartridge Only	1	+L9/1.103:AA
V2	=	068257	Valve, Proportional Cartridge PV72-30A	Valve Cartridge w/Coil	1	+L9/1.103:AA

		Wood-Mizer®	
Project Description: WM4500 Bed Extension Full			
Revision:	A3.05	Pg Desc: Parts list - Bed Extension Full	
Mounting Location: +Docs		Type: Parts list	
Prev. pg:	C1	Page:	C2
Next pg:	C3	Total Pgs:	93

Device Tag/Parts List

WM_PARTS_LIST_Fluid-Manual

Device tag	Function	Wood-Mizer Part Number	Wood-Mizer Description		Qty.	X-Ref
V3	Pressure Relief Valve	078735	Valve, Relief 250-3000psi RV10-20A Cmplt	Complete Valve Assembly	1	+L9/1.106:AD
V3	=	078672	Valve, Body 10 Size 2-Way SAE 12	Valve Body Only	1	+L9/1.106:AD
V3	=	078673	Valve, Relief 250-3000psi RV10-20A Ctg	Valve Cartridge Only	1	+L9/1.106:AD
V4	Conveyor Directional Control	078686	Valve, D05 2Pos A-B Tank		1	+L9/2.202:AA
V5	Chain Turner	078685	Valve, D05 3Pos A-B Tank		1	+L9/2.205:AA
V6	Log Loader	078685	Valve, D05 3Pos A-B Tank		1	+L9/3.302:AA
V7	Log Deck Chains	078685	Valve, D05 3Pos A-B Tank		1	+L9/4.402:AA
V8	Clamp In/Out Directional Control	078683	Valve, D03 3Pos A-B Tank		1	+L9/4.408:AA
V9	Clamp In/Out Check Valve	078738	Valve, D03 PO Check		1	+L9/4.408:AB
V10	Log Turner Up/Down	078684	Valve, D03 3Pos Blocked		1	+L9/5.502:AA
V11	Log Turner Up/Down Flow Divider	074289	Valve, 50/50 Flow Divider/Combiner		1	+L9/5.502:AC
V12	Clamp Up/Down Directional Control	078683	Valve, D03 3Pos A-B Tank		1	+L9/6.604:AA
V13	Clamp Up/Dn Check Valve	078738	Valve, D03 PO Check		1	+L9/6.604:AB
V14	Taper Roller #1 Directional Control	078683	Valve, D03 3Pos A-B Tank		1	+L9/6.606:AA
V15	Taper Roller #1 Check Valve	078738	Valve, D03 PO Check		1	+L9/6.606:AB
V16	Power Taper Roller Motors Directional Control	078683	Valve, D03 3Pos A-B Tank		1	+L9/7.702:AA
V17	Taper Roller #2 Directional Control	078683	Valve, D03 3Pos A-B Tank		1	+L9/8.804:AA
V18	Taper Roller #2 Check Valve	078738	Valve, D03 PO Check		1	+L9/8.804:AB
V19	Taper Roller #5 Up/Down	078684	Valve, D03 3Pos Blocked		1	+L9/8.806:AA
V20	Side Supports Directional Valve	078685	Valve, D05 3Pos A-B Tank		1	+L9/9.902:AA
V21	Side Supports Check Valve	078738	Valve, D03 PO Check		1	+L9/9.902:AB
V22	Power Taper Rollers 3 & 4 Up/Down Directional Valve	078685	Valve, D05 3Pos A-B Tank		1	+L9/10.1002:AA
V23	Power Taper Rollers 3 & 4 Up/Down Check Valve	078738	Valve, D03 PO Check		1	+L9/10.1002:AB
V24	Bed Extension Clamps Up/Down Directional Valve	078685	Valve, D05 3Pos A-B Tank		1	+L9/10.1006:AA
V25	Bed Extension Clamps Up/Down Check Valve	078738	Valve, D03 PO Check		1	+L9/10.1006:AB
V26	Bed Extension Clamps In/Out Directional Valve	078685	Valve, D05 3Pos A-B Tank		1	+L9/11.1102:AA
V27	Bed Extension Clamps In/Out Check Valve	078738	Valve, D03 PO Check		1	+L9/11.1102:AB
V30	Side Supports Flow Divider	074289	Valve, 50/50 Flow Divider/Combiner		1	+L9/9.904:AC
V31	Side Supports Selector Valve	074286	Valve, 3-Way Selector		1	+L9/9.906:AD
V32	Side Supports Blocking Valve	074287	Valve, 2-Way Normally Closed Blocking		1	+L9/9.907:AD
V33	Log Turner Up/Down Flow Divider	074289	Valve, 50/50 Flow Divider/Combiner		1	+L9/5.504:AC
V34	Log Turner Up/Down Selector Valve	074286	Valve, 3-Way Selector		1	+L9/5.506:AC
V37	Log Loader Flow Divider	074325	Flow Divider, 2 Section Bailey 50/50		1	+L9/3.304:AC
V38	Log Loader Selector Valve	074286	Valve, 3-Way Selector		1	+L9/3.306:AD
V39	Log Loader Blocking Valve	074287	Valve, 2-Way Normally Closed Blocking		1	+L9/3.306:AD
V40	Log Deck Chains Selector Valve	074286	Valve, 3-Way Selector		1	+L9/4.404:AC
V41	Log Deck Chains Blocking Valve	074287	Valve, 2-Way Normally Closed Blocking		1	+L9/4.405:AC
V52	Log Turner Ext Up/Down Flow Divider	025742	Flow Divider, Hydraulic		1	+L9/5.507:AC
V54	Conveyor Flow Control	078737	Valve, Press Comp Flow Ctl 12GPM Cmplt		1	+L9/2.202:AB
V54	=	078681	Valve Body, D05 Sandwich Flow Ctl Port B	Valve Body Only	1	+L9/2.202:AB
V54	=		Valve, Press Comp Flow Ctl 12GPM	Valve Cartridge Only	1	+L9/2.202:AB
V55	Bed Extension Clamps Up Selector Valve	074286	Valve, 3-Way Selector		1	+L9/10.1008:AC
V56	Bed Extension Clamps Down Selector Valve	074286	Valve, 3-Way Selector		1	+L9/10.1007:AC
V57	Bed Extension Clamps In Selector Valve	074286	Valve, 3-Way Selector		1	+L9/11.1104:AC
V58	Bed Extension Clamps Out Selector Valve	074286	Valve, 3-Way Selector		1	+L9/11.1103:AC
V59	Turner Motor Flow Divider	112589	Valve, Flow Divider 4 Sect 4.25GPM/Sect		1	+L9/2.205:AC

		Wood-Mizer®	
Project Description: WM4500 Bed Extension Full			
Revision:	A3.05	Pg Desc: Parts list - Bed Extension Full	
Mounting Location: +Docs		Type: Parts list	
Prev. pg:	C2	Page:	C3
Next pg:	C4	Total Pgs:	93

Device Tag/Parts List

WM_PARTS_LIST_Fluid-Manual

Device tag	Function	Wood-Mizer Part Number	Wood-Mizer Description	Qty.	X-Ref
V60	Power Toe Roller Motor Flow Divider	112588	Valve, Flow Divider 5 Sect 3.4GPM/Sept	1	+L9/7.702:AC

		Wood-Mizer®	
Project Description: WM4500 Bed Extension Full			
Revision:		A3.05	Pg Desc: Parts list - Bed Extension Full
Mounting Location: +Docs		Type: Parts list	
Prev. pg:	C3	Page:	C4
Next pg:	K1	Total Pgs:	93

Hose/Tube list

WM_HydraulicHoseList

Hose/Tube	Wood-Mizer PN	Color	Diameter	Length	Description	XREF
H1	078736		1-1/4 "		Suction Tube	+L9/1.104:AD
H2	078761		1/4 "		Load Sense Line	+L9/1.104:AA
H3	078760		3/4 "		Pressure Relief Line	+L9/1.104:AB
H4	078767		1/2 "		Pump Case Drain	+L9/1.105:AD
H5	078767		1-1/4 "		Filter Tank Line	+L9/1.109:AD
H6	078760		3/4 "		Pressure Line From Proportional Valve	+L9/4.404:AB
H7	078760		1 "		Tank Line From Manifold 1	+L9/1.109:AC
H8	078763		3/4 "		Pressure Line Manifold 1 To Manifold 2	+L9/2.202:AB
H10	079004-471	Blu	1/2 "	471"	Conveyor Return Line	+L9/2.203:AC
H10_X	079004-264	Blu	1/2 "	264"	Conveyor Return Line Bed Extension	+L9/2.203:AC
H11	079004-471	Red	1/2 "	471"	Conveyor Out Line	+L9/2.203:AC
H11_X	079004-264	Red	1/2 "	264"	Conveyor Out Line Bed Extension	+L9/2.203:AC
H12	079004-156	Red	1/2" "	156"	Incline Conveyor Out	+L9/2.203:AE
H13	079004-156	Blu	1/2" "	156"	Incline Conveyor Return	+L9/2.203:AE
H14	079004-144	Yel	1/2 "	144"	Turner Motors Vlv A FD In	+L9/2.206:AC
H15	079001-504	Grn	3/8 "	504"	Turner Motor Far FD Out 1 Mtr B	+L9/2.206:AD
H16	079001-480	Vlt	3/8 "	480"	Turner Motor Near FD Out 2 Mtr B	+L9/2.207:AD
H17	079004-310	Grn	1/2 "	310"	Log Loader Down T	+L9/3.305:AC
H18	079004-310	Yel	1/2 "	310"	Log Loader Down T	+L9/3.302:AD
H19	079001-72	Grn	3/8 "	72"	Log Loader Up T to C1	+L9/3.302:AE
H20	079001-72	Grn	3/8 "	72"	Log Loader Up T to C2	+L9/3.302:AE
H21	079001-72	Yel	3/8 "	72"	Log Loader Down T to C1	+L9/3.302:AE
H22	079001-72	Yel	3/8 "	72"	Log Loader Down T to C2	+L9/3.302:AE
H23	079004-310	Org	1/2 "	310"	Log Deck Forward Line	+L9/4.404:AC
H24	079004-310	Wht	1/2 "	310"	Log Deck Valve B To Deck 1 Motor A	+L9/4.403:AC
H24_X	079004-264	Wht	1/2 "	264"	Log Deck Valve B To Deck 1 Motor A Bed Extension	+L9/4.403:AC
H25	079001-364	Org	3/8 "	364"	Clamp In Line	+L9/4.409:AC
H25_X	079001-264	Org	3/8 "	264"	Clamp In Line Bed Extension	+L9/4.409:AC
H26	079001-364	Wht	3/8 "	364"	Clamp Out Line	+L9/4.409:AC
H26_X	079001-264	Wht	3/8 "	264"	Clamp Out Line Bed Extension	+L9/4.409:AC
H27	079001-275	Pnk	3/8 "	275"	Log Turner Up T2 To T3	+L9/5.505:AE
H28	079001-85		3/8 "	85"	Log Turner Down Valve B To FD 3	+L9/5.503:AC
H29	079001-19	Pnk	3/8 "	19"	Log Turner Up T To Cylinder Near	+L9/5.502:AE
H30	079001-39	Pnk	3/8 "	39"	Log Turner Up T To Cylinder Far	+L9/5.502:AE
H31	079001-200		3/8 "	200"	Log Turner Down FD2 To Cylinder Near	+L9/5.502:AD
H32	079001-216		3/8 "	216"	Log Turner Down FD4 To Cylinder Far	+L9/5.502:AD
H33	079001-364	Yel	3/8 "	364"	Clamp Up Line	+L9/6.605:AC
H33_X	079001-264	Yel	3/8 "	264"	Clamp Up Line Bed Extension	+L9/6.605:AC
H34	079001-364	Grn	3/8 "	364"	Clamp Down Line	+L9/6.605:AC



Wood-Mizer®

Project Description: WM4500 Bed Extension Full

Revision:	A3.05	Pg Desc:	Hose/Tube List-Bed Extension Full
Mounting Location:	+Docs	Type:	Connection list
Prev. pg:	C4	Page:	K1
		Next pg:	K2
		Total Pgs:	93

Hose/Tube list

WM_HydraulicHoseList

Hose/Tube	Wood-Mizer PN	Color	Diameter	Length	Description	XREF
H34_X	079001-264	Grn	3/8 "	264"	Clamp Down Line Bed Extension	+L9/6.605:AC
H35	079000-267	Gry	1/4 "	267"	Taper Roller #1 Up Line	+L9/6.607:AD
H35_X	079000-264	Gry	1/4 "	264"	Taper Roller #1 Up Line Bed Extension	+L9/6.607:AC
H36	079000-270	Yel	1/4 "	270"	Taper Roller #1 Down Line	+L9/6.607:AC
H36_X	079000-264	Yel	1/4 "	264"	Taper Roller #1 Down Line Bed Extension	+L9/6.607:AC
H37	079004-144	Red	1/2 "	144"	Power Toe Roller Vlv A FD In	+L9/7.703:AC
H38	079000-540	Red	1/4 "	540"	Power Toe Roller #1 FD Out 1 Mtr A	+L9/7.702:AE
H39	079000-456	Blu	1/4 "	456"	Power Toe Roller #2 FD Out 2 Mtr A	+L9/7.703:AE
H40	079000-333	Blk	1/4 "	333"	Taper Roller #2 Up Line	+L9/8.805:AC
H40_X	079000-264	Blk	1/4 "	264"	Taper Roller #2 Up Line Bed Extension	+L9/8.805:AC
H41	079000-335	Vlt	1/4 "	335"	Taper Roller #2 Down Line	+L9/8.805:AC
H41_X	079000-264	Vlt	1/4 "	264"	Taper Roller #2 Down Line Bed Extension	+L9/8.805:AC
H42	079000-384	Blu	1/4 "	384"	Taper Roller #5 Up Line	+L9/8.807:AD
H43	079000-384	Red	1/4 "	384"	Taper Roller #5 Down Line	+L9/8.807:AD
H44	079001-190	Vlt	3/8 "	190"	Side Supports Up T1	+L9/9.908:AE
H45	079001-190	Blk	3/8 "	190"	Side Supports Down FD 4 T To T1	+L9/9.904:AD
H46	079001-120	Vlt	3/8 "	120"	Side Supports Up T2 to Far Cylinder	+L9/9.902:AE
H47	079001-51	Vlt	3/8 "	51"	Side Supports Up T1 to Near Cylinder	+L9/9.902:AE
H48	079001-122	Blk	3/8 "	122"	Side Supports Down T2 to Far Cylinder	+L9/9.902:AD
H49	079001-51	Blk	3/8 "	51"	Side Supports Down T1 to Near Cylinder	+L9/9.903:AD
H52	079000-492	Wht	1/4 "	492"	Taper Roller #3 & #4 Up Line	+L9/10.1003:AD
H53	079000-492	Org	1/4 "	492"	Taper Roller #3 & #4 Down Line	+L9/10.1003:AC
H54	079000-132	Blu	1/4 "	132"	Taper Roller #3 Up Line	+L9/10.1003:AD
H55	079000-132	Red	1/4 "	132"	Taper Roller #3 Down Line	+L9/10.1003:AC
H56	079001-364	Yel	3/8 "	364"	Clamp 2 Up SV 3 To Cylinder	+L9/10.1007:AD
H57	079001-364	Grn	3/8 "	364"	Clamp 2 Down SV 3 To Cylinder	+L9/10.1007:AD
H58	079001-364	Org	3/8 "	364"	Clamp 2 In SV 3 To Cylinder	+L9/11.1103:AD
H59	079001-364	Wht	3/8 "	364"	Clamp 2 Out SV 3 To Cylinder	+L9/11.1103:AD
H60	079004-264	Grn	1/2 "	264"	Log Loader Up Flow Divider IN	+L9/3.303:AC
H61	079004-240	Grn	1/2 "	240"	Log Loader Up FD OUT1 to SV 2	+L9/3.305:AD
H62	079004-240	Grn	1/2 "	240"	Log Loader Up FD OUT2 T To SV 1	+L9/3.305:AC
H63	079004-360	Grn	1/2 "	360"	Log Loader Up BV 2 To Up T	+L9/3.305:AE
H64	079001-72	Grn	3/8 "	72"	Log Loader Up T to C1	+L9/3.305:AE
H65	079001-72	Grn	3/8 "	72"	Log Loader Up T to C2	+L9/3.305:AE
H66	079004-264	Yel	1/2 "	264"	Log Loader Down T Bed Extension	+L9/3.302:AD
H67	079004-120	Yel	1/2 "	120"	Log Loader Down T to T	+L9/3.302:AD
H68	079001-72	Yel	3/8 "	72"	Log Loader Down T to C1	+L9/3.305:AE
H69	079001-72	Yel	3/8 "	72"	Log Loader Down T to C2	+L9/3.305:AE
H70	079004-144	Org	1/2 "	144"	Log Deck Valve A to SV 2	+L9/4.403:AC

		Wood-Mizer®	
Project Description: WM4500 Bed Extension Full			
Revision:	A3.05	Pg Desc: Hose/Tube List-Bed Extension Full	
Mounting Location: +Docs		Type: Connection list	
Prev. pg:	K1	Page:	K2
Next pg:		K3	Total Pgs: 93

Hose/Tube list

WM_HydraulicHoseList

Hose/Tube	Wood-Mizer PN	Color	Diameter	Length	Description	XREF
H72	079004-312	Org	1/2 "	312"	Log Deck SV 3 To 2nd Motor B	+L9/4.406:AC
H73	079004-312	Wht	1/2 "	312"	Log Deck BV 2 To 2nd Motor A	+L9/4.406:AC
H74	079001-65	Pnk	3/8 "	65"	Log Turner Up T1 To T2	+L9/5.505:AE
H75	079001-24		3/8 "	24"	Log Turner Down FD 4 to FD 3	+L9/5.502:AC
H76	079001-42		3/8 "	42"	Log Turner Down SV 1 to FD 3	+L9/5.502:AC
H77	079001-42		3/8 "	42"	Log Turner Down FD 2 to SV 2	+L9/5.505:AC
H78	079001-288		3/8 "	288"	Log Turner Down FD2 To Cylinder Near Bed Extension	+L9/5.502:AD
H79	079001-288		3/8 "	288"	Log Turner Down FD4 To Cylinder Far Bed Extension	+L9/5.502:AD
H80	079001-48		3/8 "	48"	Log Turner Down SV 3 to FD 3	+L9/5.506:AC
H81	079001-240	Pnk	3/8 "	240"	Log Turner Down Valve A To Base T1	+L9/5.505:AE
H82	079001-120	Blk	3/8 "	120"	Side Supports Down Valve B To FD 3	+L9/9.903:AC
H83	079001-42	Blk	3/8 "	42"	Side Supports Down FD 4 T To SV 12	+L9/9.905:AC
H84	079001-36	Blk	3/8 "	36"	Side Supports Down FD 2 To SV 2	+L9/9.905:AD
H85	079001-300	Blk	3/8 "	300"	Side Supports Down BV 2 To T1	+L9/9.909:AC
H86	079001-180	Blk	3/8 "	180"	Side Supports Down FD 4 T To Union	+L9/9.904:AD
H87	079001-78	Blk	3/8 "	78"	Side Supports Down T2 to Far Cylinder	+L9/9.909:AC
H88	079001-54	Blk	3/8 "	54"	Side Supports Down T1 to Near Cylinder	+L9/9.909:AC
H89	079001-240	Vlt	3/8 "	240"	Side Supports Up Valve A To T1	+L9/9.909:AE
H90	079001-54	Vlt	3/8 "	54"	Side Supports Up T3 to Far Cylinder	+L9/9.908:AE
H91	079001-54	Vlt	3/8 "	54"	Side Supports Up T1 to Near Cylinder	+L9/9.909:AE
H92	079000-372	Grn	1/4 "	372"	Power Toe Roller #3 FD Out 3 Mtr A	+L9/7.704:AE
H93	079000-288	Vlt	1/4 "	288"	Power Toe Roller #4 FD Out 4 Mtr A	+L9/7.706:AE
H94	079000-192	Yel	1/4 "	192"	Power Toe Roller #5 FD Out 5 Mtr A	+L9/7.706:AD
H95	079000-144	Pnk	1/4 "	144"	Power Toe Roller #1 Mtr B Tee 1	+L9/7.703:AE
H96	079001-336	Yel	3/8 "	336"	Turner Motor Far FD Out 3 Mtr B	+L9/2.208:AD
H97	079001-216	Pnk	3/8 "	216"	Turner Motor Near FD Out 4 Mtr B	+L9/2.209:AD
H98	079001-72	Org	3/8 "	72"	Turner Motor Far A Tee 1	+L9/2.207:AE
H99	079004-360	Wht	3/8 "	360"	Turner Motor Near A Tee 1	+L9/2.207:AE
H118	079001-84	Pnk	3/8 "	84"	Log Turner Up T2 To Cylinder	+L9/5.505:AE
H119	079001-84	Pnk	3/8 "	84"	Log Turner Up T1 To Cylinder	+L9/5.505:AE
H120	079001-216	Blk	3/8 "	216"	Log Turner Ext FD 2 To Far Cylinder	+L9/5.505:AE
H121	079001-84	Pnk	3/8 "	84"	Log Turner Ext FD 4 To Near Cylinder	+L9/5.505:AE
H122	079001-240	Blk	3/8 "	240"	Turner Motor Tee 1 Tee 2	+L9/2.208:AE
H123	079001-144	Yel	3/8 "	144"	Bed Extension Clamps Up Valve A To SV 2	+L9/10.1008:AC
H124	079001-144	Grn	3/8 "	144"	Bed Extension Clamps Down Valve B To SV 2	+L9/10.1008:AC
H125	079001-144	Org	3/8 "	144"	Bed Extension Clamps In Valve A To SV 2	+L9/11.1104:AC
H126	079001-144	Wht	3/8 "	144"	Bed Extension Clamps Out Valve B To SV 2	+L9/11.1103:AC
H127	079001-364	Yel	3/8 "	364"	Clamp 3 Up SV 1 To Cylinder	+L9/10.1008:AD
H128	079001-364	Grn	3/8 "	364"	Clamp 3 Down SV 1 To Cylinder	+L9/10.1008:AD

		Wood-Mizer®	
Project Description: WM4500 Bed Extension Full			
Revision:	A3.05	Pg Desc: Hose/Tube List-Bed Extension Full	
Mounting Location: +Docs		Type: Connection list	
Prev. pg:	K2	Page:	K3
Next pg:		K4	Total Pgs: 93

Hose/Tube list

WM_HydraulicHoseList

Hose/Tube	Wood-Mizer PN	Color	Diameter	Length	Description	XREF
H129	079001-364	Org	3/8 "	364"	Clamp 3 In SV 1 To Cylinder	+L9/11.1104:AD
H130	079001-364	Wht	3/8 "	364"	Clamp 3 Out SV 1 To Cylinder	+L9/11.1104:AD
H132	079000-36	Org	1/4 "	36"	Power Toe Roller #2 Mtr B Tee 1	+L9/7.703:AE
H133	079001-41	Vlt	3/8 "	41"	Side Supports Up T1 To T2	+L9/9.902:AE
H134	079001-41	Blk	3/8 "	41"	Side Supports Down T1 To T2	+L9/9.902:AD
H135	079001-55	Vlt	3/8 "	55"	Side Supports Up T2 to Middle Cylinder	+L9/9.902:AE
H136	079001-59	Blk	3/8 "	59"	Side Supports Down T2 to Middle Cylinder	+L9/9.902:AD
H137	079000-24	Blu	1/4 "	24"	Taper Roller #4 Up Line	+L9/10.1004:AD
H138	079000-24	Red	1/4 "	24"	Taper Roller #4 Down Line	+L9/10.1004:AC
H139	079001-48	Blk	3/8 "	48"	Side Supports Down T1 To T2	+L9/9.909:AC
H140	079001-48	Vlt	3/8 "	48"	Side Supports Up T1 To T2	+L9/9.909:AE
H141	079001-54	Blk	3/8 "	54"	Side Supports Down T2 to Middle Cylinder	+L9/9.909:AC
H142	079001-54	Vlt	3/8 "	54"	Side Supports Up T2 to Middle Cylinder	+L9/9.909:AE
H143	079001-60	Vlt	3/8 "	60"	Side Supports Up T2 to T3	+L9/9.908:AE
H144	079001-48		3/8 "	48"	BX Turner Motor Far A Tee 2	+L9/2.208:AE
H145	079004-120	Gry	1/2 "	120"	Turner Motor Tee 2 Tee 3	+L9/2.209:AE
H146	079001-48	Red	3/8 "	48"	BX Turner Motor Near A Tee 3	+L9/2.209:AE
H148	079001-168	Red	3/8 "	168"	Power Toe Roller Mtr Tee 1 Tee 2	+L9/7.704:AE
H149	079000-36	Wht	1/4 "	36"	Power Toe Roller #3 Mtr B Tee 2	+L9/7.704:AE
H150	079004-121	Blu	1/2 "	121"	Power Toe Roller Mtr Tee 2 Tee 3	+L9/7.706:AE
H151	079000-		1/4 "		Taper Roller #1 Up Line 2	+L9/6.607:AD
H152	079000-		1/4 "		Taper Roller #1 Down Line 2	+L9/6.607:AC
H153	079000-		1/4 "		Taper Roller #2 Up Line 2	+L9/8.804:AD
H154	079000-		1/4 "		Taper Roller #2 Down Line 2	+L9/8.804:AD
H155	079000-		1/4 "		Taper Roller #3 Up Line 2	+L9/10.1003:AD
H156	079000-		1/4 "		Taper Roller #3 Down Line 2	+L9/10.1003:AC
H157	079000-		1/4 "		Taper Roller #4 Up Line 2	+L9/10.1004:AD
H158	079000-		1/4 "		Taper Roller #4 Down Line 2	+L9/10.1004:AC
H159	079000-		1/4 "		Taper Roller #5 Up Line 2	+L9/8.807:AD
H160	079000-		1/4 "		Taper Roller #5 Down Line 2	+L9/8.807:AD
H161	079000-36	Blk	1/4 "	36"	Power Toe Roller #4 Mtr B Tee 3	+L9/7.706:AE
H162	079004-168	Grn	1/2 "	168"	Power Toe Roller Mtr Tee 3 Tee 4	+L9/7.706:AD
H163	079000-36		1/4 "	36"	Power Toe Roller #5 Mtr B Tee 4	+L9/7.706:AD
H164	079004-240	Vlt	1/2 "	240"	Power Toe Roller Mtr Tee 4 Valve B	+L9/7.706:AD
H165	079001-144	Blu	3/8 "	144"	Power Toe Roller FD Drn MFLD3 T	+L9/11.1104:AC
H166	079004-252	Org	1/2 "	252"	Turner Motor Tee 3 Vlv B	+L9/2.209:AE
H167	079001-144	Blu	3/8 "	144"	Turner Motor FD Drn MFLD3 T	+L9/11.1104:AC

		Wood-Mizer®	
Project Description: WM4500 Bed Extension Full			
Revision: A3.05		Pg Desc: Hose/Tube List-Bed Extension Full	
Mounting Location: +Docs		Type: Connection list	
Prev. pg: K3	Page: K4	Next pg: &MPA+/A1	Total Pgs: 93

Revision History

Date	Revision	Revision Record	Drawn By	Checked By
8/6/18	A1.00	Release to production	JRF	SDC

		Wood-Mizer®	
Project Description: WM4500 Bed Extension Full			
Revision: A3.05		Pg Desc: Revision History	
Mounting Location: +		Type: Overview	
Prev. pg: A1	Page: B1	Next pg: +L11.L12/1	Total Pgs: 93

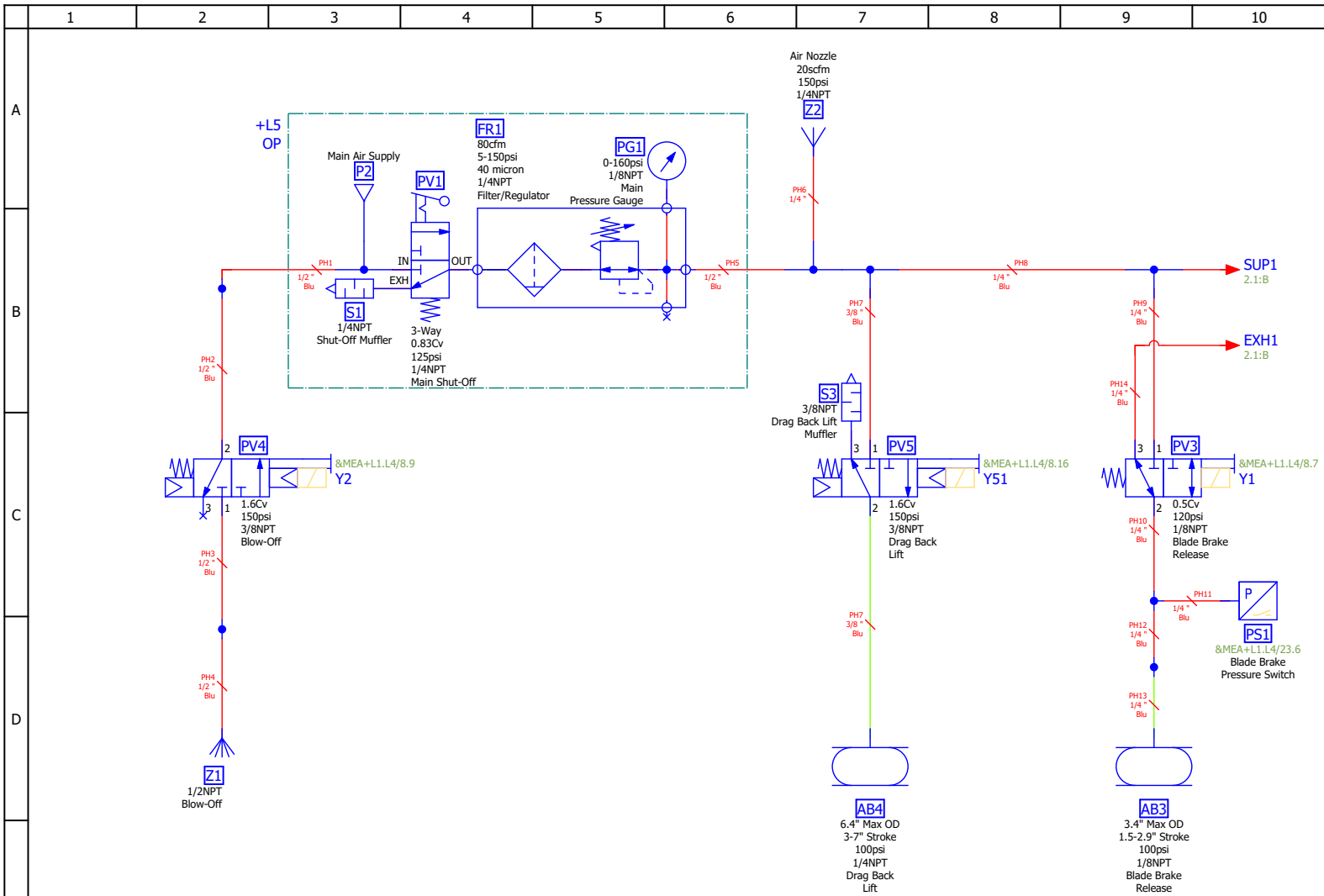

Wood-Mizer®			
Project Description: WM4500 Bed Extension Full			
Revision:	A3.05	Pg Desc:	Pneumatics Pg 1
Mounting Location:	+L11.L12	Type:	Fluid power schematic
Prev. pg:	+/B1	Page:	1
Next pg:	2	Total Pgs:	93

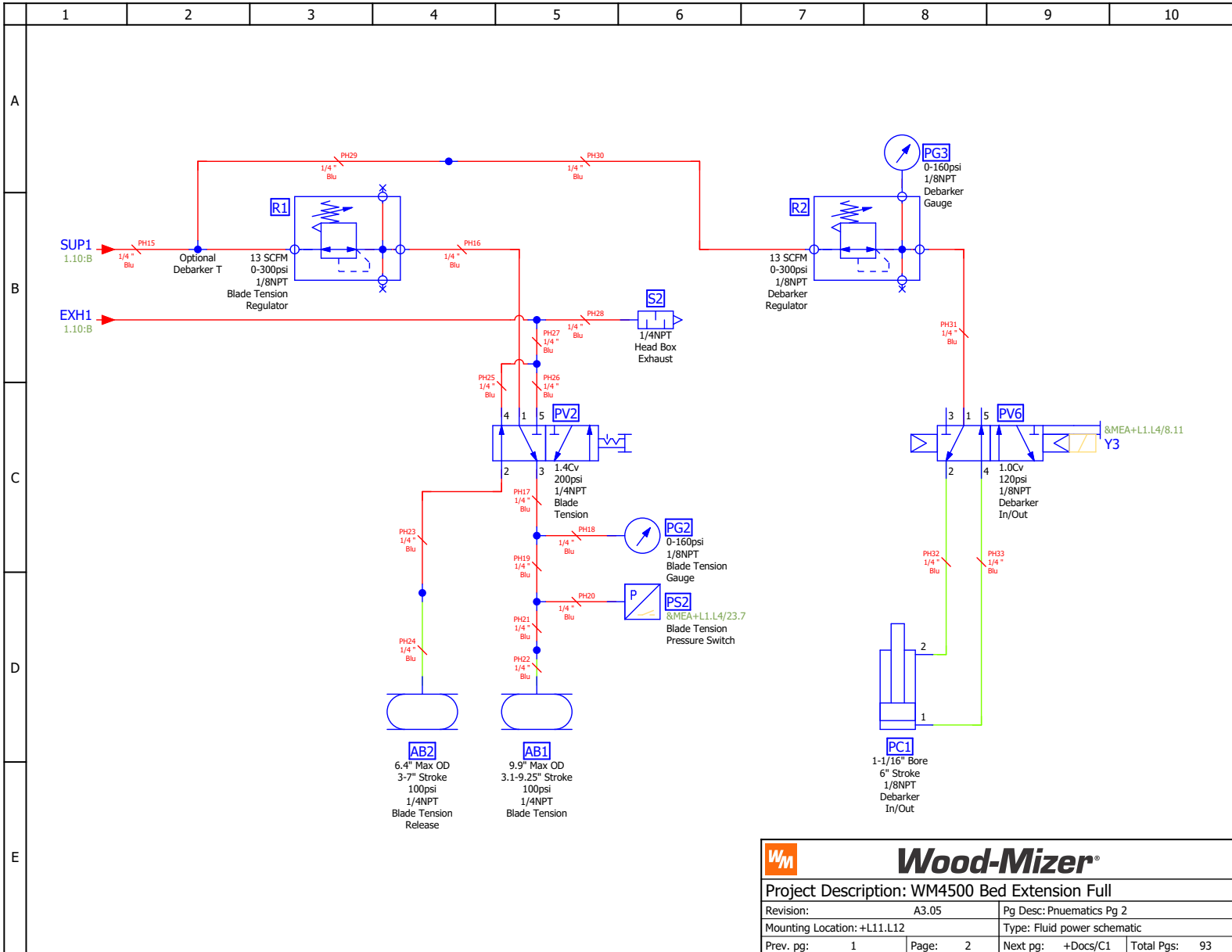

Wood-Mizer®	
Project Description: WM4500 Bed Extension Full	
Revision: A3.05	Pg Desc: Pneumatics Pg 2
Mounting Location: +L11.L12	Type: Fluid power schematic
Prev. pg: 1	Page: 2
Next pg: +Docs/C1	Total Pgs: 93

Device Tag/Parts List

Device tag	Function	Wood-Mizer Part Number	Wood-Mizer Description		Qty.	X-Ref
AB1	Blade Tension	033229	Bag, Tensioner Air		1	+L11.L12/2.205:AD
AB2	Blade Tension Release	033231	Bag, Motor Lift Air		1	+L11.L12/2.204:AD
AB3	Blade Brake Release	033168	Bag, Air Brake		1	+L11.L12/1.109:AD
AB4	Drag Back Lift	033231	Bag, Motor Lift Air		1	+L11.L12/1.107:AD
FR1	Filter/Regulator	110953	Air Filter/Regulator		1	+L11.L12/1.104:AA
FR1	=	110956	Assy, Air Filter Mount	Mount	1	+L11.L12/1.104:AA
PC1	Debarker In/Out	008766	Cylinder, 1-1/16x6, Air		1	+L11.L12/2.208:AD
PG1	Main Pressure Gauge	P02766	Gauge, 160 PSI, 1-1/2 Dia, 1/8 NPT		1	+L11.L12/1.106:AA
PG2	Blade Tension Gauge	042342	Gauge, Air Pressure		1	+L11.L12/2.206:AC
PG3	Debarker Gauge	042342	Gauge, Air Pressure		1	+L11.L12/2.208:AA
PV1	Main Shut-Off	P21513	Valve, Air		1	+L11.L12/1.104:AB
PV2	Blade Tension	025301	Valve, Push Pull 4 Way 1/4 NPT		1	+L11.L12/2.205:AC
PV3	Blade Brake Release	045225	Valve, Air 3 Way 1/8 NPT Din C Conn		1	+L11.L12/1.109:AC
PV4	Blow-Off	042659	Valve Assy, Air		1	+L11.L12/1.102:AC
PV5	Drag Back Lift	042659	Valve Assy, Air		1	+L11.L12/1.107:AC
PV6	Debarker In/Out	025244	Valve, MAC 400 Series		1	+L11.L12/2.208:AC
R1	Blade Tension Regulator	052509	Regulator, 1/8" NPT Air		1	+L11.L12/2.203:AB
R2	Debarker Regulator	052509	Regulator, 1/8" NPT Air		1	+L11.L12/2.207:AB
S1	Shut-Off Muffler	P20904	Mufflet, 1/4 in. NPT Air		1	+L11.L12/1.103:AB
S2	Head Box Exhaust	P20904	Mufflet, 1/4 in. NPT Air		1	+L11.L12/2.206:AB
S3	Drag Back Lift Muffler	P21528	Mufflet, CEC-3 3/8 in. NPT Air		1	+L11.L12/1.107:AC
Z1	Blow-Off	016879	Block, Blow-Off 1/2		1	+L11.L12/1.102:AD
Z2	Air Nozzle	P02714	Nozzle, Coolant Spray		1	+L11.L12/1.107:AA

		Wood-Mizer®	
Project Description: WM4500 Bed Extension Full			
Revision:	A3.05	Pg Desc: Parts list	
Mounting Location: +Docs		Type: Parts list	
Prev. pg: +L11.L12/2	Page: C1	Next pg: K1	Total Pgs: 93

Hose/Tube list

WM_HydraulicHoseList

Hose/Tube	Wood-Mizer PN	Color	Diameter	Length	Description	XREF
PH1	R01869-5	Blu	1/2 "	960"	Blow-Off Supply Line	+L11.L12/1.102:AB
PH2	R01869-5	Blu	1/2 "	31"	Blow-Off Supply Line Head Box	+L11.L12/1.102:AB
PH3	R01869-5	Blu	1/2 "	33"	Blow-Off Output Line Head Box	+L11.L12/1.102:AD
PH4	R01869-5	Blu	1/2 "		Blow-Off Output Line	+L11.L12/1.102:AD
PH5	R01869-4	Blu	1/2 "	960"	Head Supply Line	+L11.L12/1.106:AB
PH6	042453		1/4 "		Air Nozzle Hose	+L11.L12/1.106:AB
PH7	R01869-4	Blu	3/8 "		Drag Back Fingers Lift Line	+L11.L12/1.107:AD
PH7	R01869-4	Blu	3/8 "	10"	Drag Back Fingers Supply Line	+L11.L12/1.107:AB
PH8	R01869-3	Blu	1/4 "	22"	Supply Line Head Box	+L11.L12/1.109:AB
PH9	R01869-3	Blu	1/4 "	7.5"	Blade Brake Supply Line	+L11.L12/1.109:AB
PH10	R01869-3	Blu	1/4 "	10"	Blade Brake Line Valve To Y	+L11.L12/1.109:AC
PH11	R01869-3	Blu	1/4 "	29.5"	Blade Brake Line Y To Pressure Switch	+L11.L12/1.109:AC
PH12	R01869-3	Blu	1/4 "	6.5"	Blade Brake Line Y To Bulkhead	+L11.L12/1.109:AD
PH13	R01869-3	Blu	1/4 "		Blade Brake Line Bulkhead To Brake	+L11.L12/1.109:AD
PH14	R01869-3	Blu	1/4 "	8.5"	Blade Brake Exhaust Valve To Y	+L11.L12/2.205:AB
PH15	R01869-3	Blu	1/4 "	3"	Blade Tension Supply Y To Regulator	+L11.L12/1.109:AB
PH16	R01869-3	Blu	1/4 "	6.5"	Blade Tension Supply Regulator To Valve	+L11.L12/2.205:AC
PH17	R01869-3	Blu	1/4 "	3"	Blade Tension Line Valve To Pressure Gauge T	+L11.L12/2.205:AC
PH18	R01869-3	Blu	1/4 "	1.5"	Blade Tension Line T To Pressure Gauge	+L11.L12/2.205:AC
PH19	R01869-3	Blu	1/4 "	9"	Blade Tension Line Pressure Gauge T To Pressure Switch Y	+L11.L12/2.205:AD
PH20	R01869-3	Blu	1/4 "	9"	Blade Tension Line Y To Pressure Switch	+L11.L12/2.205:AD
PH21	R01869-3	Blu	1/4 "	10.5"	Blade Tension Line Y To Bulkhead	+L11.L12/2.205:AD
PH22	R01869-3	Blu	1/4 "		Blade Tension Line Bulkhead To Air Bag	+L11.L12/2.205:AD
PH23	R01869-3	Blu	1/4 "	22"	Blade Tension Release Valve To Bulkhead	+L11.L12/2.204:AD
PH24	R01869-3	Blu	1/4 "		Blade Tension Release Bulkhead To Air Bag	+L11.L12/2.204:AD
PH25	R01869-3	Blu	1/4 "	3.5"	Blade Tension Exhaust Valve To Y	+L11.L12/2.205:AB
PH26	R01869-3	Blu	1/4 "	3.5"	Blade Tension Exhaust Valve To Y	+L11.L12/2.205:AB
PH27	R01869-3	Blu	1/4 "	5"	Blade Tension Exhaust Y To Y	+L11.L12/2.205:AB
PH28	R01869-3	Blu	1/4 "	18"	Head Box Exhaust Y To Muffler	+L11.L12/2.205:AB
PH29	R01869-3	Blu	1/4 "		Debarker Supply T To Bulkhead	+L11.L12/2.204:AA
PH30	R01869-3	Blu	1/4 "		Debarker Supply Bulkhead To Regulator	+L11.L12/2.204:AA
PH31	R01869-3	Blu	1/4 "		Debarker Supply Regulator To Valve	+L11.L12/2.208:AC
PH32	R01869-3	Blu	1/4 "		Debarker In Line Valve To Cylinder	+L11.L12/2.208:AD
PH33	R01869-3	Blu	1/4 "		Debarker Out Line Valve To Cylinder	+L11.L12/2.208:AD

		Wood-Mizer®	
Project Description: WM4500 Bed Extension Full			
Revision: A3.05		Pg Desc: Hose list	
Mounting Location: +Docs		Type: Connection list	
Prev. pg: C1	Page: K1	Next pg:	Total Pgs: 93