

APPENDIX A ELECTRICAL INFORMATION

WM4500 StandardRev. A4.03+

Table of contents

WM_TableOfContents

Page	Page type	Page description	Date	Edited by
&MEA/A1	Table of contents	Table of contents	7/15/2024	JRF
&MEA/A2	Table of contents	Table of contents	7/15/2024	JRF
&MEA/B1	Overview	Revision History	7/15/2024	JRF
&MEA+L1.L3/1	Schematic multi-line	Power Pg 1	5/14/2024	JRF
&MEA+L1.L3/2	Schematic multi-line	Power Pg 2	5/14/2024	JRF
&MEA+L1.L3/3	Schematic multi-line	Power Pg 3	5/14/2024	JRF
&MEA+L1.L3/4	Schematic multi-line	Control Pg 1	5/14/2024	JRF
&MEA+L1.L3/5	Schematic multi-line	Control Pg 2	5/14/2024	JRF
&MEA+L1.L3/6	Schematic multi-line	Control Pg 3	5/14/2024	JRF
&MEA+L1.L4/7	Schematic multi-line	Control Pg 4	5/14/2024	JRF
&MEA+L1.L4/8	Schematic multi-line	Control Pg 5	5/14/2024	JRF
&MEA+L1.L4/9	Schematic multi-line	Control Pg 6	5/14/2024	JRF
&MEA+L1.L4/10	Schematic multi-line	Control Pg 7	5/14/2024	JRF
&MEA+L1.L4/11	Schematic multi-line	Control Pg 8	5/14/2024	JRF
&MEA+L1.L4/12	Schematic multi-line	Control Pg 9	5/14/2024	JRF
&MEA+L1.L4/13	Schematic multi-line	Control Pg 10	5/14/2024	JRF
&MEA+L1.L4/14	Schematic multi-line	Control Pg 11	5/14/2024	JRF
&MEA+L1.L4/15	Schematic multi-line	Control Pg 12	5/14/2024	JRF
&MEA+L1.L4/16	Schematic multi-line	Control Pg 13	5/14/2024	JRF
&MEA+L1.L4/17	Schematic multi-line	Control Pg 14	5/14/2024	JRF
&MEA+L1.L4/18	Schematic multi-line	Control Pg 15	5/14/2024	JRF
&MEA+L1.L4/19	Schematic multi-line	Communication	5/14/2024	JRF
&MEA+L1.L4/20	Panel layout	PLC Diagram	4/25/2024	JRF
&MEA+L1.L4/21	Schematic multi-line	PLC 1	5/14/2024	JRF
&MEA+L1.L4/22	Schematic multi-line	PLC 2	5/14/2024	JRF
&MEA+L1.L4/23	Schematic multi-line	PLC 3	5/14/2024	JRF
&MEA+L1.L4/24	Schematic multi-line	PLC 4	5/14/2024	JRF
&MEA+L1.L4/25	Schematic multi-line	PLC 5	5/14/2024	JRF
&MEA+L1.L4/26	Schematic multi-line	PLC 6	5/14/2024	JRF
&MEA+L1.L4/27	Schematic multi-line	PLC 7	5/14/2024	JRF
&MEA+L1.L4/28	Schematic multi-line	PLC 8	5/14/2024	JRF
&MEA+L1.L4/29	Schematic multi-line	PLC 9	5/14/2024	JRF
&MEA+L1.L4/30	Schematic multi-line	PLC 10	5/14/2024	JRF
&MEA+L1.L4/31	Schematic multi-line	PLC 11	5/14/2024	JRF
&MEA+L1.L4/32	Schematic multi-line	PLC 12	5/14/2024	JRF
&MEA+L1.L4/33	Schematic multi-line	PLC 13	5/14/2024	JRF
&MEA+L1.L4/34	Schematic multi-line	PLC 14	5/14/2024	JRF
&MEA+L1.L4/35	Schematic multi-line	PLC 15	5/14/2024	JRF



		Wood-Mizer®	
Project Description: WM4500 Standard			
Revision:	A4.04	Pg Desc: Table of contents	
Mounting Location: +		Type: Table of contents	
Prev. pg:	Page: A1	Next pg: A2	Total Pgs: 89

Table of contents

WM_TableOfContents

Page	Page type	Page description	Date	Edited by
&MEA+L5.L7/36	Schematic multi-line	HMI 1	5/14/2024	JRF
&MEA+L9/37	Schematic multi-line	Pull Down Clamp Module	5/14/2024	JRF
&MEA+L9/38	Schematic multi-line	Pull Down Clamp 1	5/14/2024	JRF
&MEA+L9/39	Schematic multi-line	Pull Down Clamp 2	5/14/2024	JRF
&MEA+Docs/C1	Parts list	Parts list	4/25/2024	JRF
&MEA+Docs/C2	Parts list	Parts list	4/25/2024	JRF
&MEA+Docs/C3	Parts list	Parts list	4/25/2024	JRF
&MEA+Docs/D1	Terminal line-up diagram	Terminal line-up diagram	4/25/2024	JRF
&MEA+Docs/D2	Terminal line-up diagram	Terminal line-up diagram	4/25/2024	JRF
&MEA+Docs/D3	Terminal line-up diagram	Terminal line-up diagram	4/25/2024	JRF
&MEA+Docs/D4	Terminal line-up diagram	Terminal line-up diagram	4/25/2024	JRF
&MEA+Docs/D5	Terminal line-up diagram	Terminal line-up diagram	4/25/2024	JRF
&MEA+Docs/D6	Terminal line-up diagram	Terminal line-up diagram	4/25/2024	JRF
&MEA+Docs/D7	Terminal line-up diagram	Terminal line-up diagram	4/25/2024	JRF
&MEA+Docs/D8	Terminal line-up diagram	Terminal line-up diagram	4/25/2024	JRF
&MEA+Docs/E1	Cable overview	Cable overview	4/25/2024	JRF
&MEA+Docs/E2	Cable overview	Cable overview	4/25/2024	JRF
&MEA+Docs/F1	Panel layout	Main Control Layout	4/25/2024	JRF
&MEA+Docs/F2	Panel layout	Main Control Disconnect Layout	4/25/2024	JRF
&MEA+Docs/F3	Panel layout	Main Control High Voltage Layout	4/25/2024	JRF
&MEA+Docs/F4	Panel layout	Main Control Low Voltage Layout	4/25/2024	JRF
&MEA+Docs/F5	Panel layout	Operator Ctl Layout	4/25/2024	JRF
&MEA+Docs/F6	Panel layout	Operator Ctl Solenoid Layout	4/25/2024	JRF
&MEA+Docs/F7	Panel layout	Operator Ctl Junction Layout	4/25/2024	JRF
&MEA+Docs/F8	Panel layout	Operator Ctl HMI Layout	4/25/2024	JRF
&MEA+Docs/F9	Panel layout	Operator Ctl Bed Ex Layout	4/25/2024	JRF
&MEA+Docs/F10	Panel layout	Operator Ctl Side Supports Layout	4/25/2024	JRF
&MEA+Docs/F11	Panel layout	Hydraulic Control Layout	4/25/2024	JRF
&MEA+Docs/F12	Panel layout	Hydraulic Control Junction Layout	4/25/2024	JRF
&MEA+Docs/F13	Panel layout	Head Control Layout	4/25/2024	JRF
&MEA+Docs/F14	Panel layout	Head Control Junction Layout	4/25/2024	JRF

		Wood-Mizer®	
Project Description: WM4500 Standard			
Revision:	A4.04	Pg Desc: Table of contents	
Mounting Location: +		Type: Table of contents	
Prev. pg:	A1	Page:	A2
		Next pg:	B1
		Total Pgs:	89

Revision History

Date	Revision	Revision Record	Drawn By	Checked By
8/6/18	A1.00	Release to production	JRF	SDC
4/26/19	A2.00	Added Pull Down Clamp Functions	JRF	SDC
12/6/19	A3.00	Full Bed Extension	JRF	SDC
2/13/24	A4.03	Blade Motor Soft Start (SSD1) - OBS of 069933 replaced with 069933-A1	MM	JRF
4/25/24	A4.04	Modbus network update for termination resistor	JRF	***

		Wood-Mizer®	
Project Description: WM4500 Standard			
Revision: A4.04		Pg Desc: Revision History	
Mounting Location: +		Type: Overview	
Prev. pg: A2	Page: B1	Next pg: +L1.L3/1	Total Pgs: 89

Voltage	480VAC +4/-10%
Phase	3Ph
Frequency	60 Hz
FLA Machine	94.1A
FLA Largest Load	38A
Wiring Diagram	
SCCR	5kA

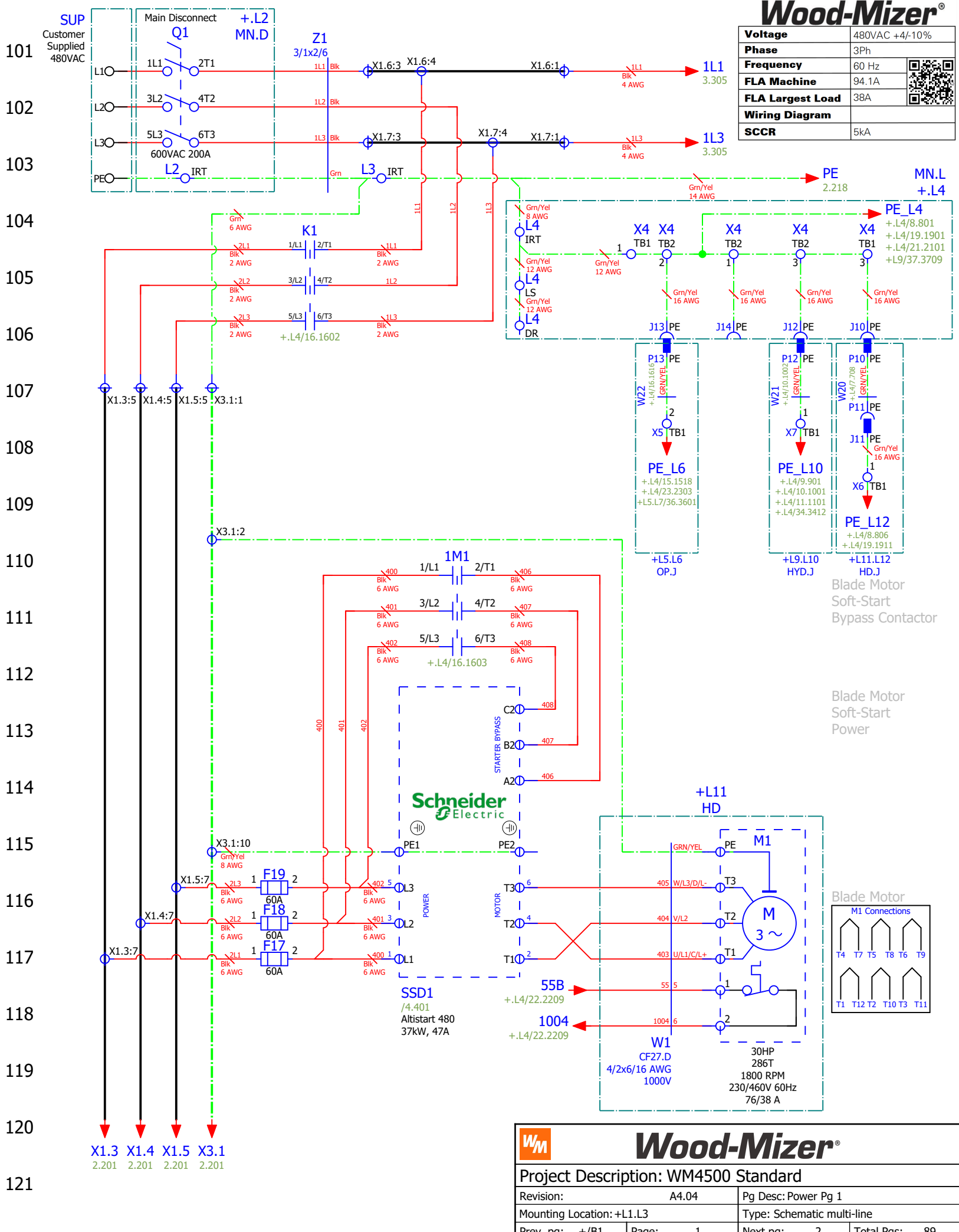

Blade Motor
Soft-Start
Bypass Contactor

Blade Motor
Soft-Start
Power

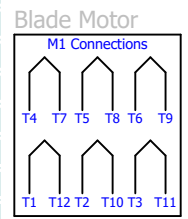

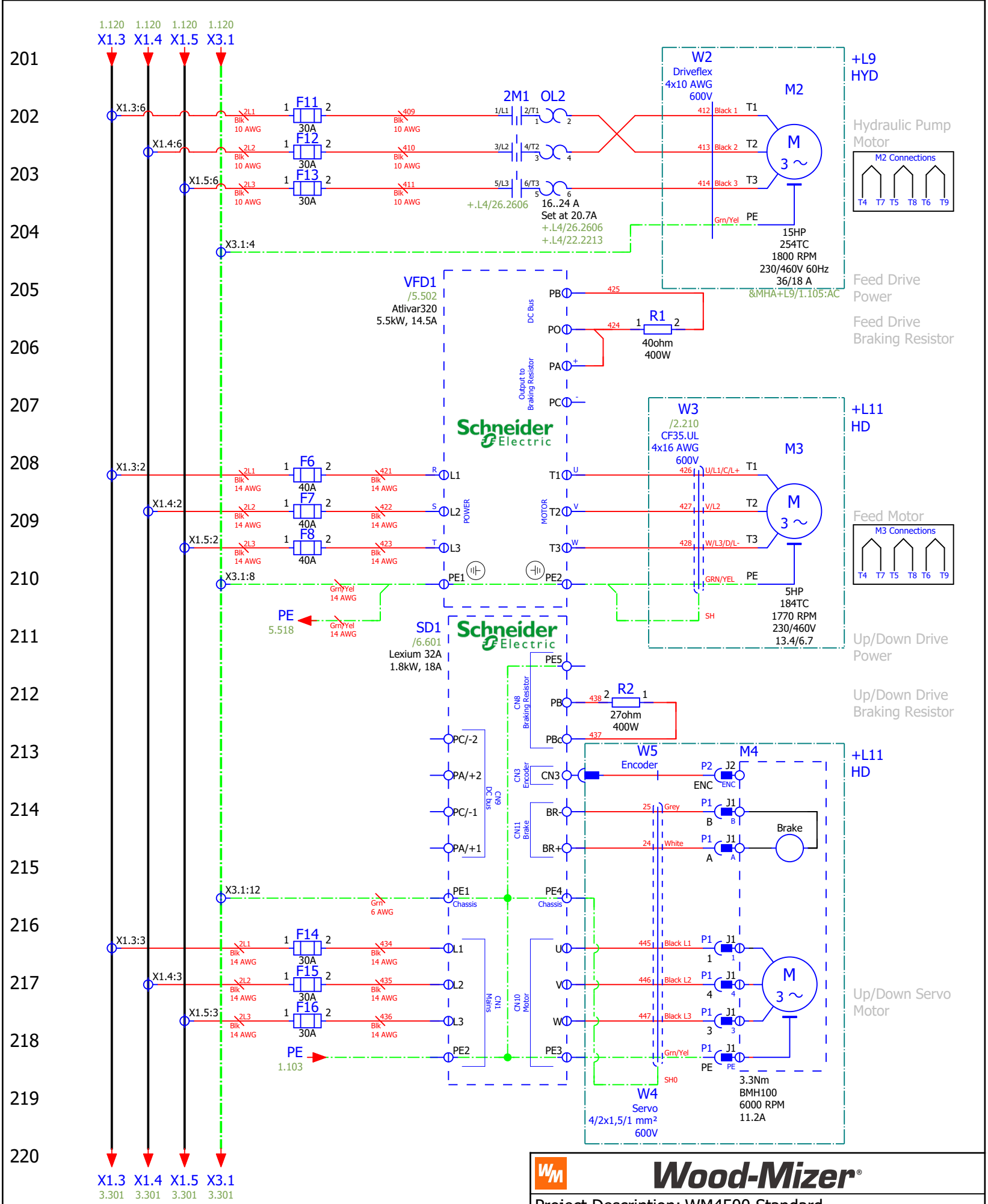

+L9 HYD

Hydraulic Pump Motor

M2 Connections

T4 T7 T5 T8 T6 T9

Feed Drive Power

Feed Drive Braking Resistor

+L11 HD

Feed Motor

M3 Connections

T4 T7 T5 T8 T6 T9

Up/Down Drive Power

Up/Down Drive Braking Resistor

+L11 HD

Up/Down Servo Motor

Wood-Mizer®			
Project Description: WM4500 Standard			
Revision:	A4.04	Pg Desc: Power Pg 2	
Mounting Location:	+L1.L3	Type: Schematic multi-line	
Prev. pg:	1	Page:	2
		Next pg:	3
		Total Pgs:	89

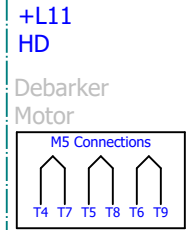
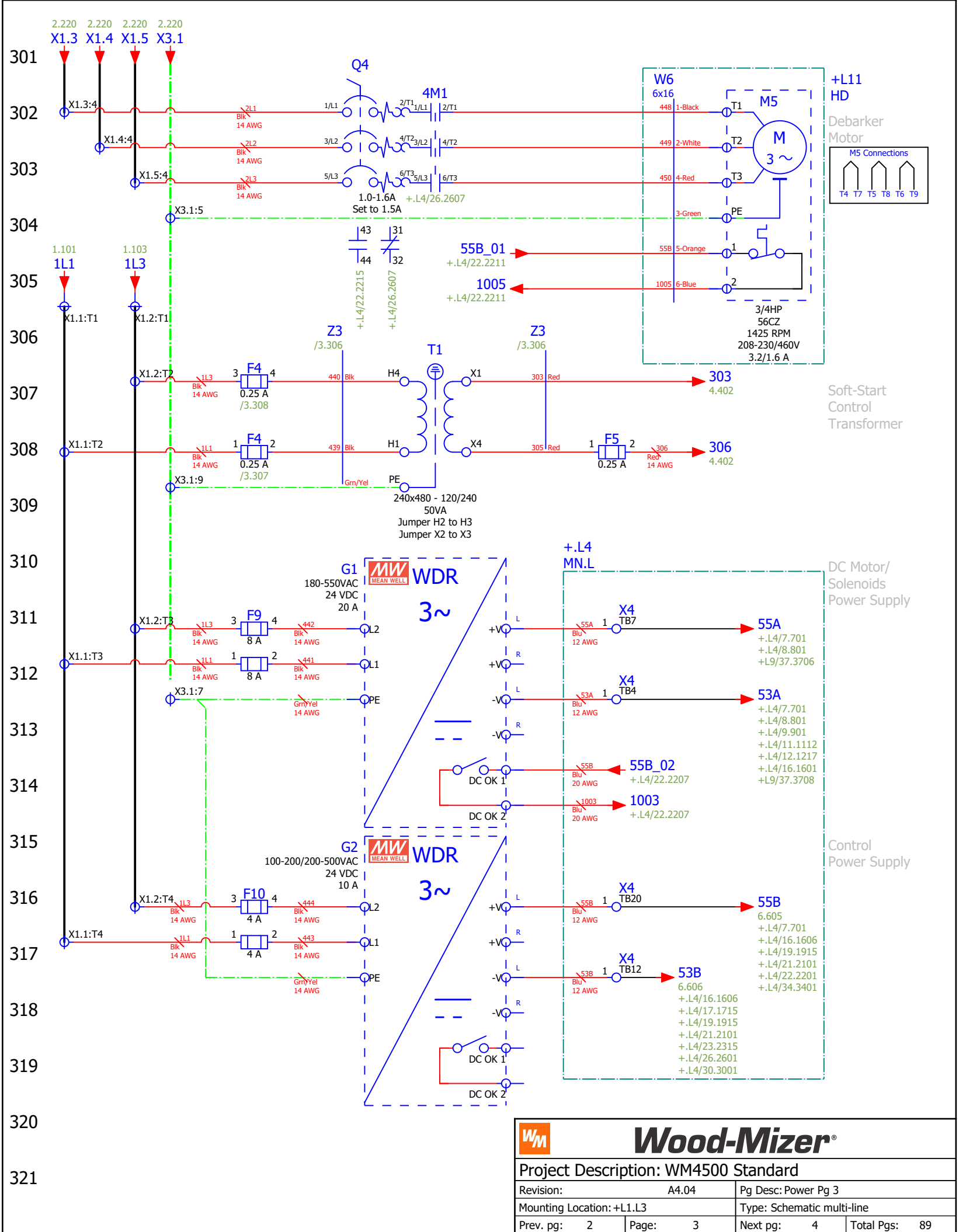

Soft-Start
Control
Transformer

DC Motor/
Solenoids
Power Supply

Control
Power Supply

Wood-Mizer®			
Project Description: WM4500 Standard			
Revision:	A4.04	Pg Desc: Power Pg 3	
Mounting Location:	+L1.L3	Type: Schematic multi-line	
Prev. pg:	2	Page:	3
		Next pg:	4
		Total Pgs:	89

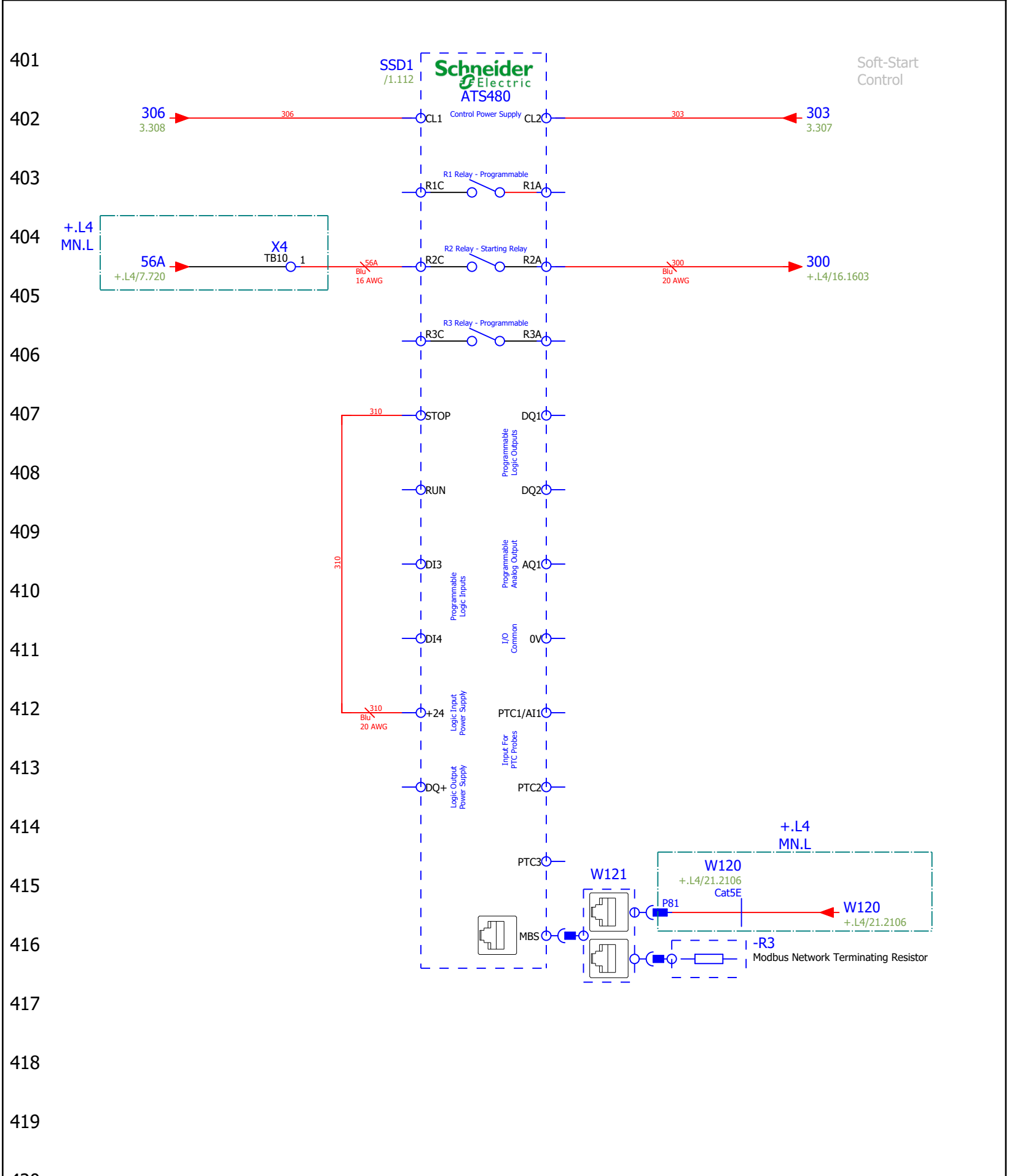

Soft-Start Control

501
502
503
504
505
506
507
508
509
510
511
512
513
514
515
516
517
518
519
520
521

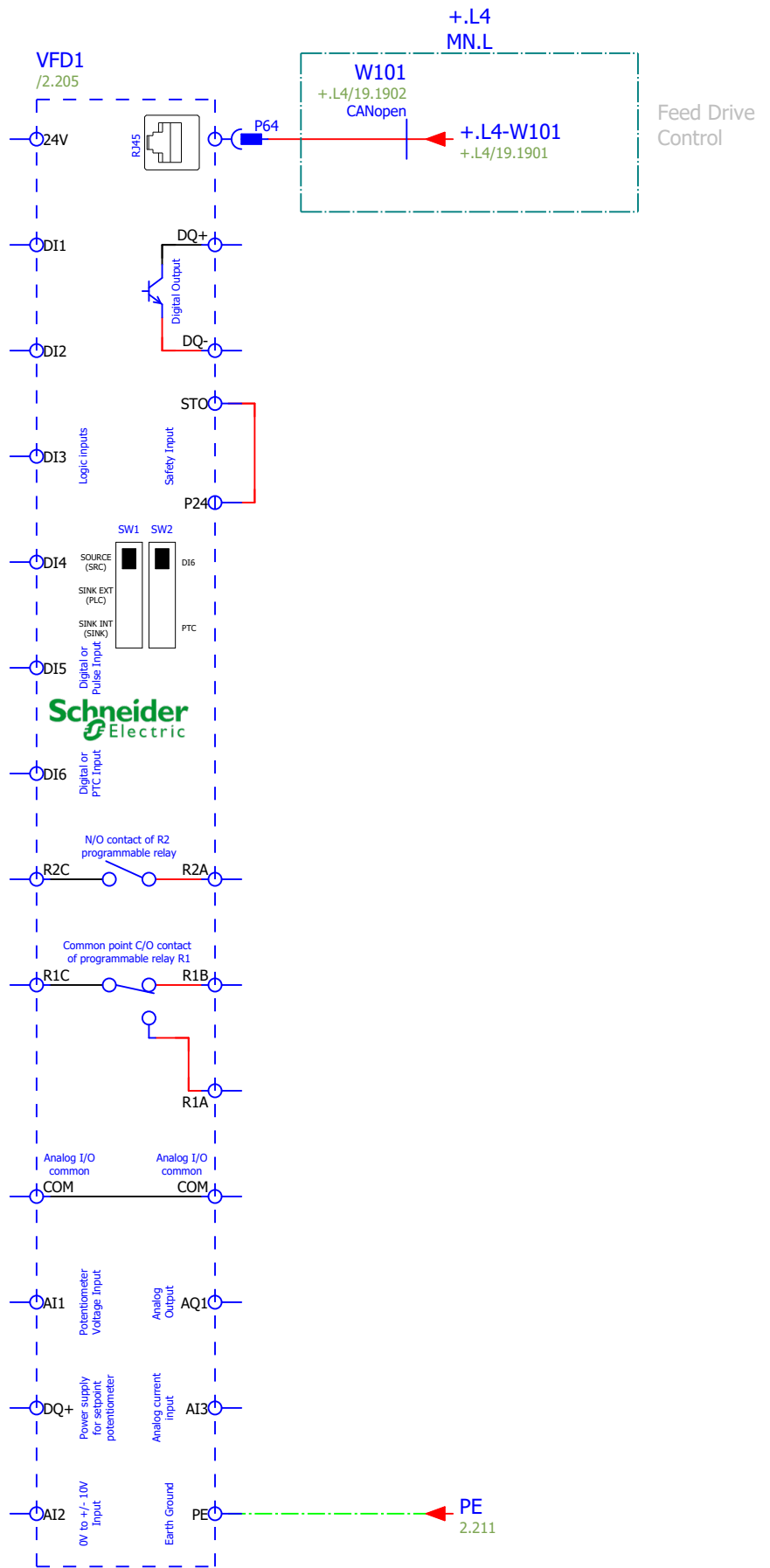

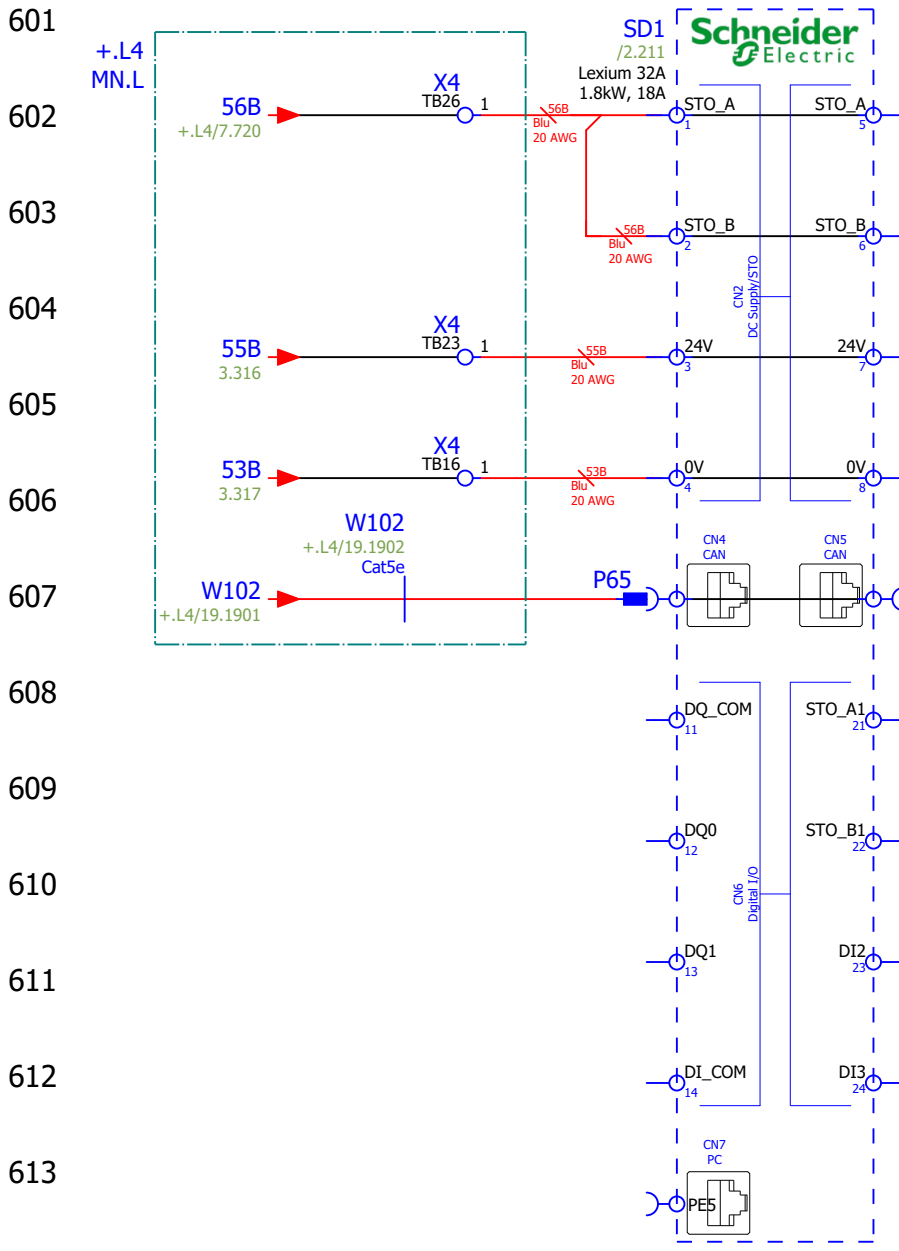

601
602
603
604
605
606
607
608
609
610
611
612
613
614
615
616
617
618
619
620
621

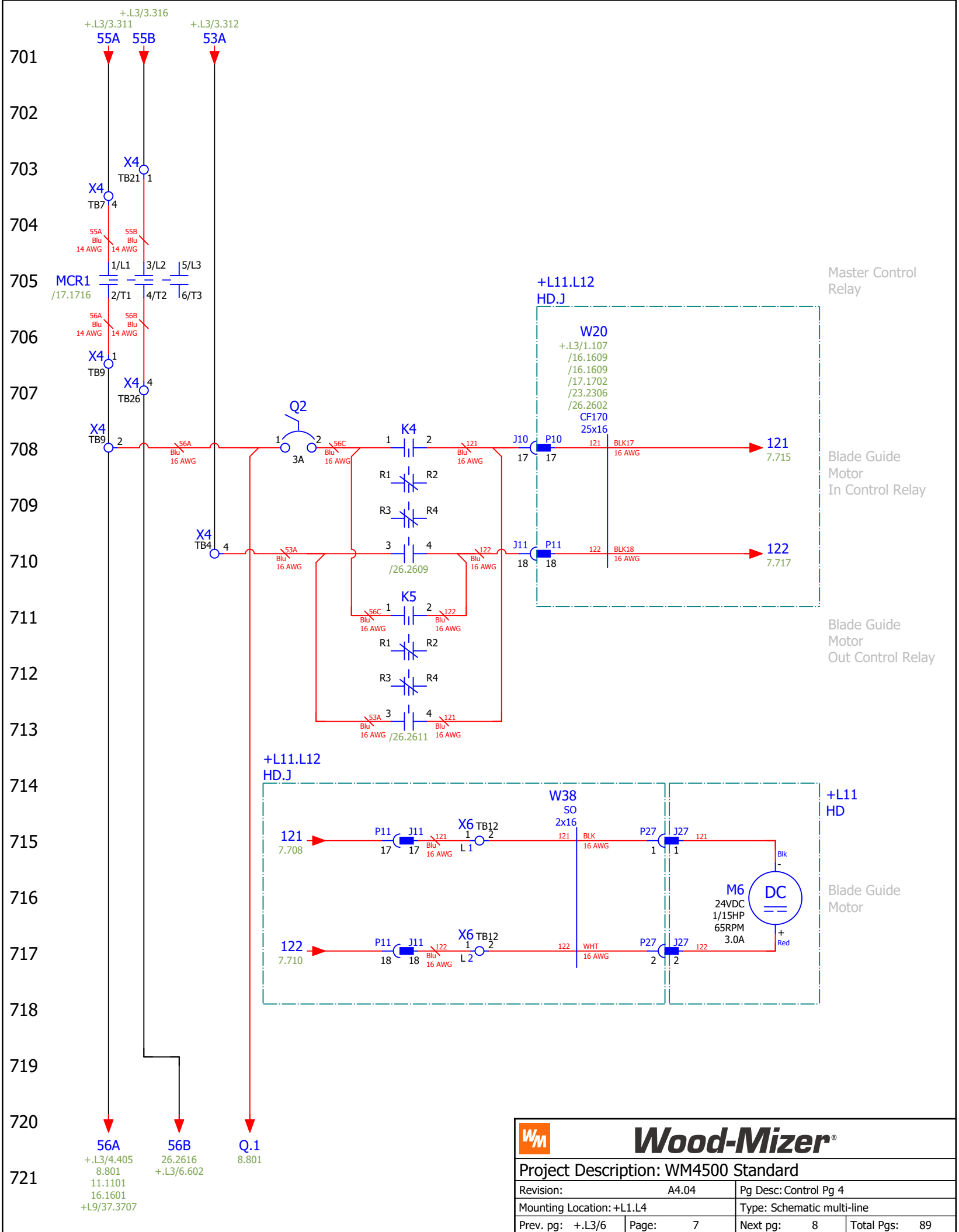

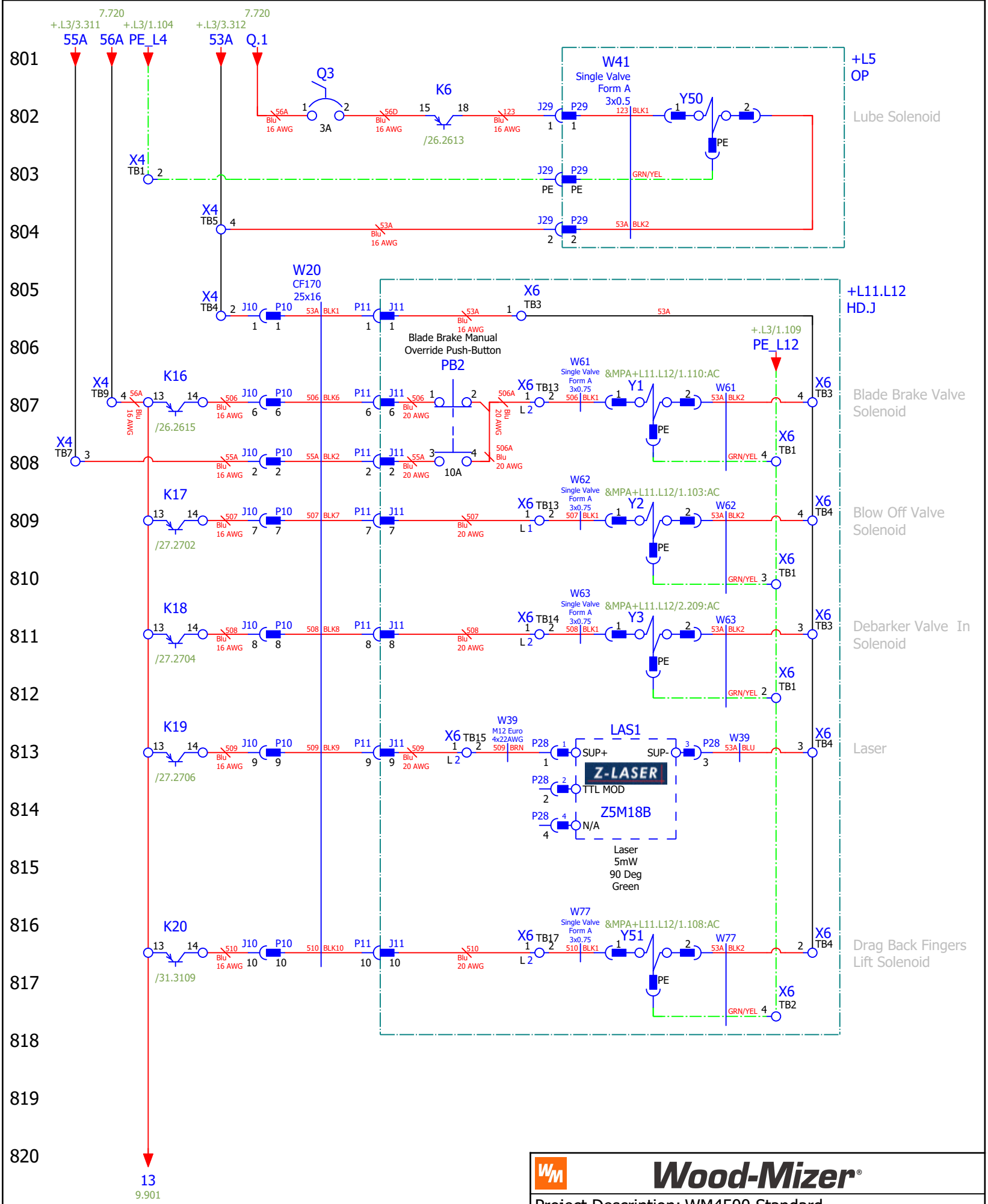

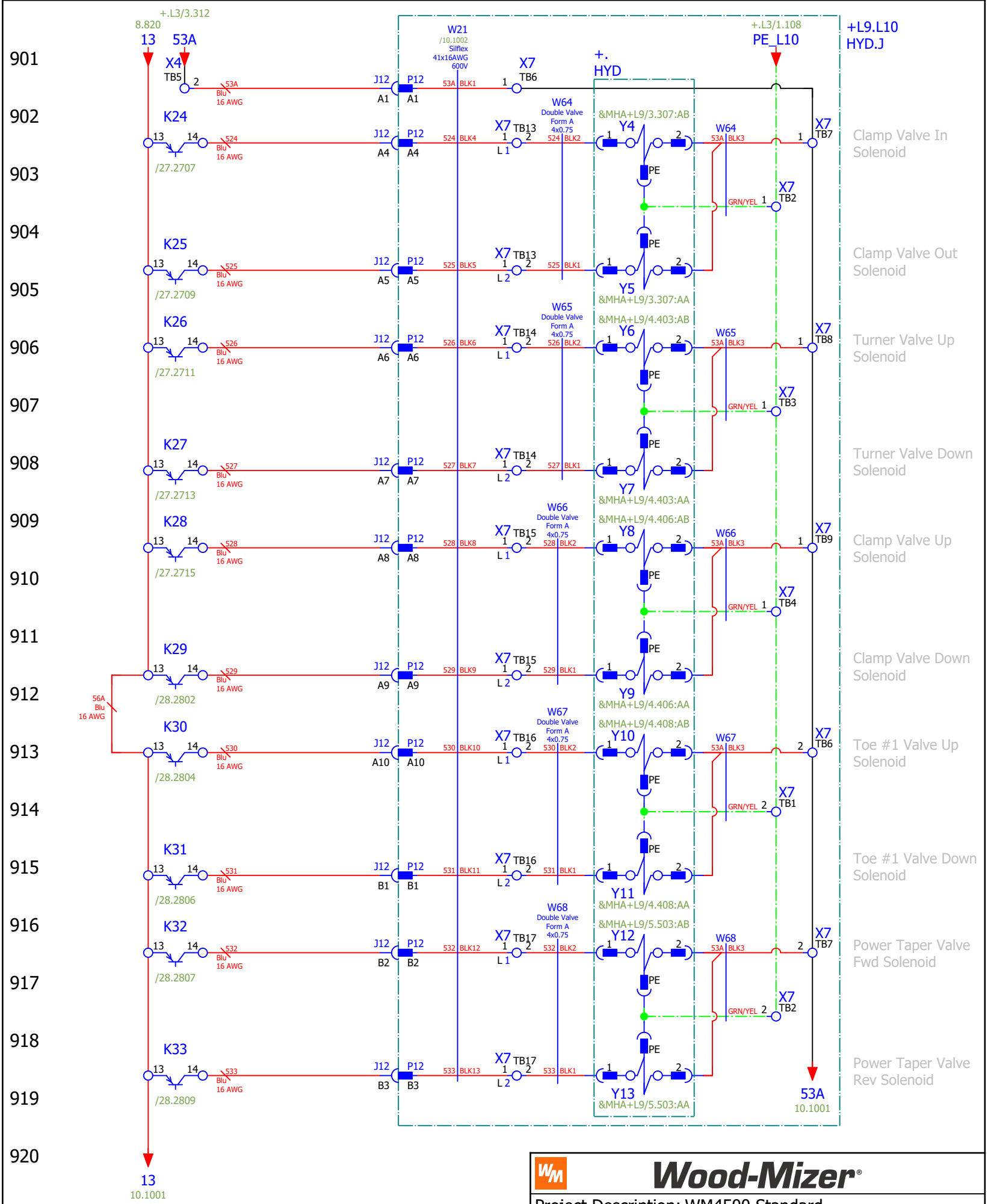

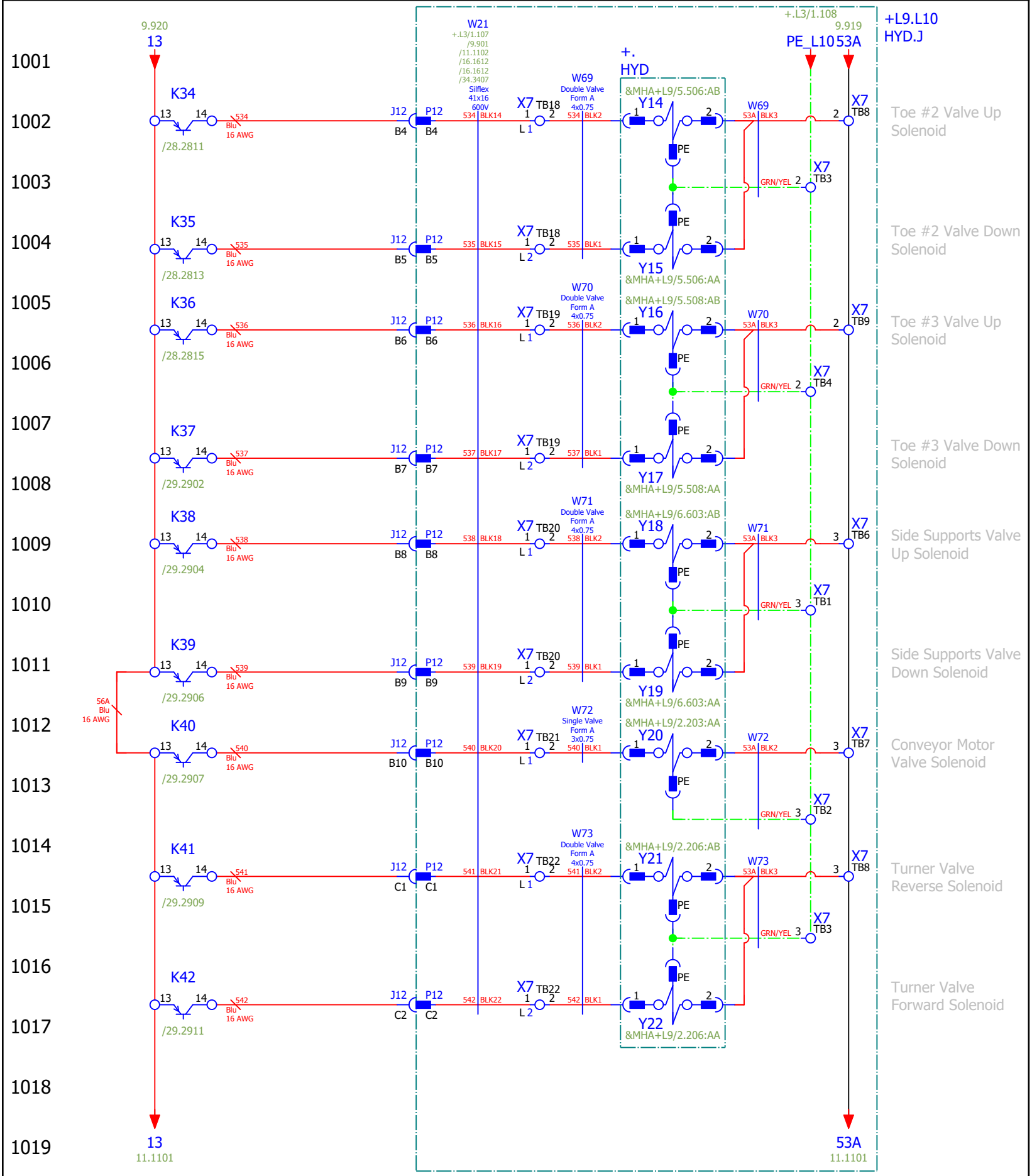

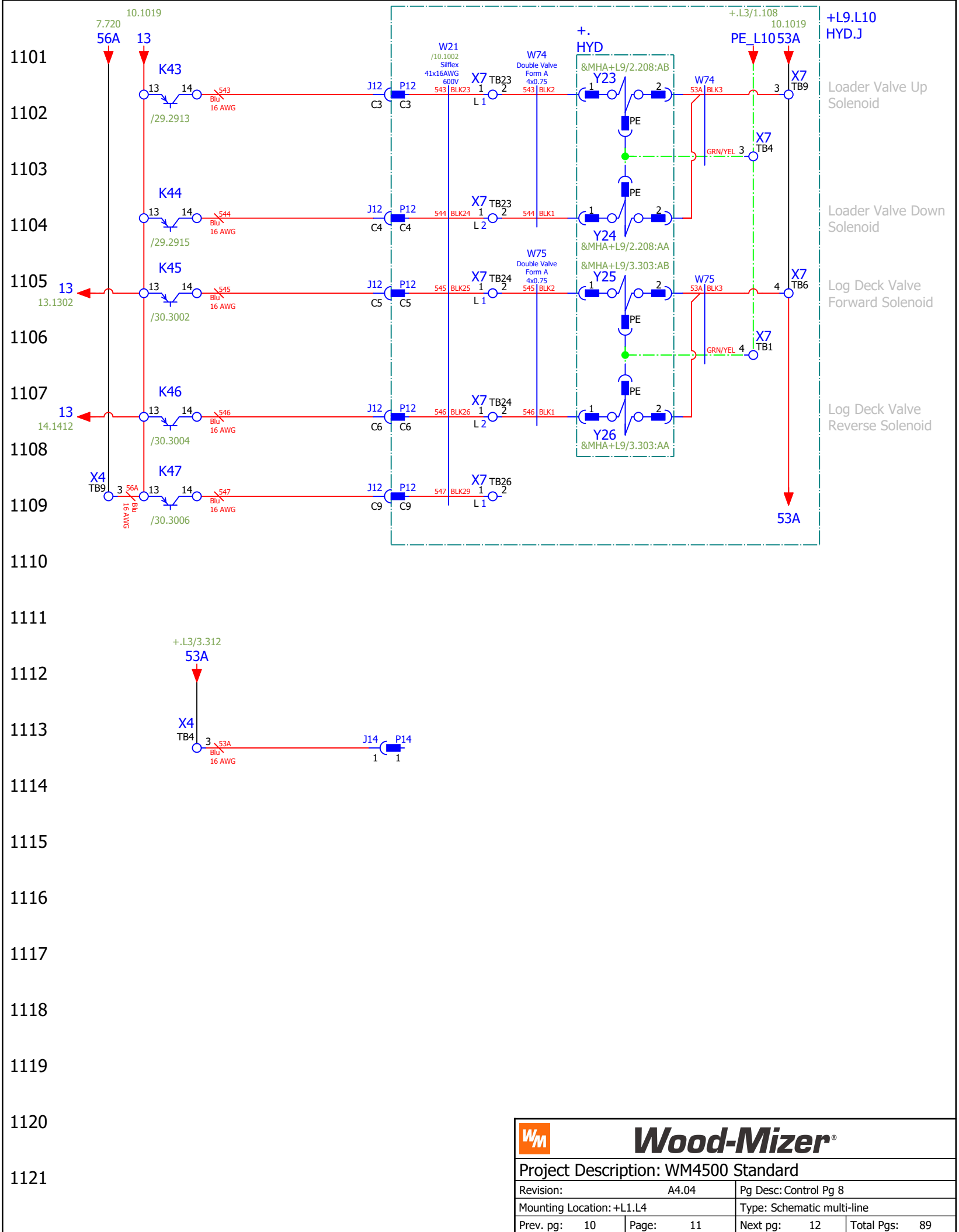

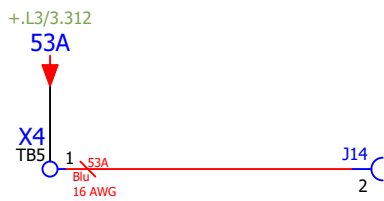

1201
1202
1203
1204
1205
1206
1207
1208
1209
1210
1211
1212
1213
1214
1215
1216
1217
1218
1219
1220
1221

Left Mostly
Empy Intentionally
For Optional
Bed Extension



		Wood-Mizer®	
Project Description: WM4500 Standard			
Revision: A4.04		Pg Desc: Control Pg 9	
Mounting Location: +L1.L4		Type: Schematic multi-line	
Prev. pg: 11	Page: 12	Next pg: 13	Total Pgs: 89

1301
1302
1303
1304
1305
1306
1307
1308
1309
1310
1311
1312
1313
1314
1315
1316
1317
1318
1319
1320
1321

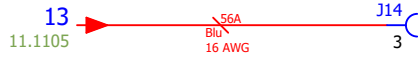

Left Mostly
Empy Intentionally
For Optional
Bed Extension

		Wood-Mizer®	
Project Description: WM4500 Standard			
Revision: A4.04		Pg Desc: Control Pg 10	
Mounting Location: +L1.L4		Type: Schematic multi-line	
Prev. pg: 12	Page: 13	Next pg: 14	Total Pgs: 89

1401
1402
1403
1404
1405
1406
1407
1408
1409
1410
1411
1412
1413
1414
1415
1416
1417
1418
1419
1420
1421

Left Mostly
Empy Intentionally
For Optional
Bed Extension



		Wood-Mizer®	
Project Description: WM4500 Standard			
Revision: A4.04		Pg Desc: Control Pg 11	
Mounting Location: +L1.L4		Type: Schematic multi-line	
Prev. pg: 13	Page: 14	Next pg: 15	Total Pgs: 89

1501
1502
1503
1504
1505
1506
1507
1508
1509
1510
1511
1512
1513
1514
1515
1516
1517
1518
1519
1520
1521

Left Mostly
Empty Intentionally
For Optional
Bed Extension

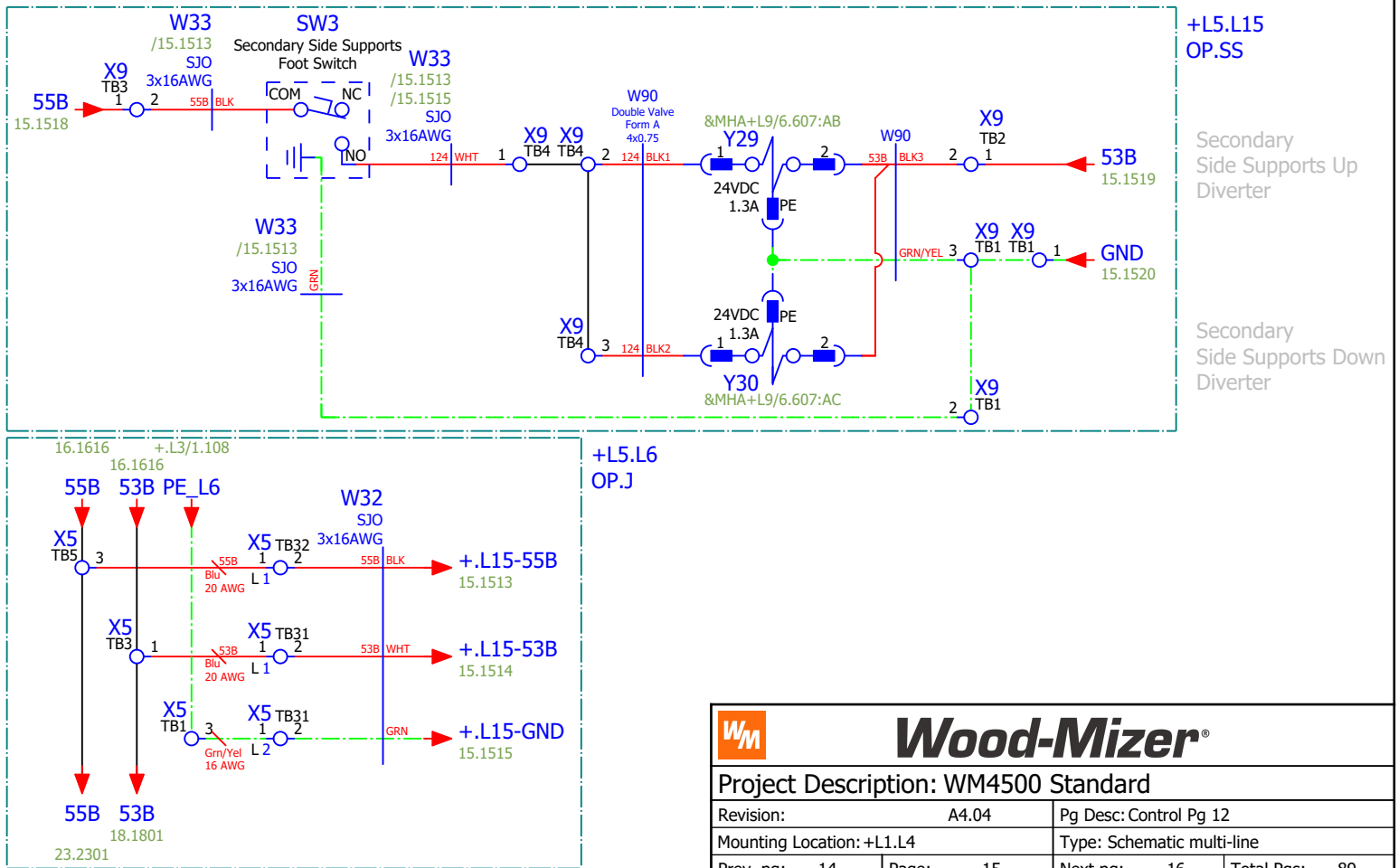

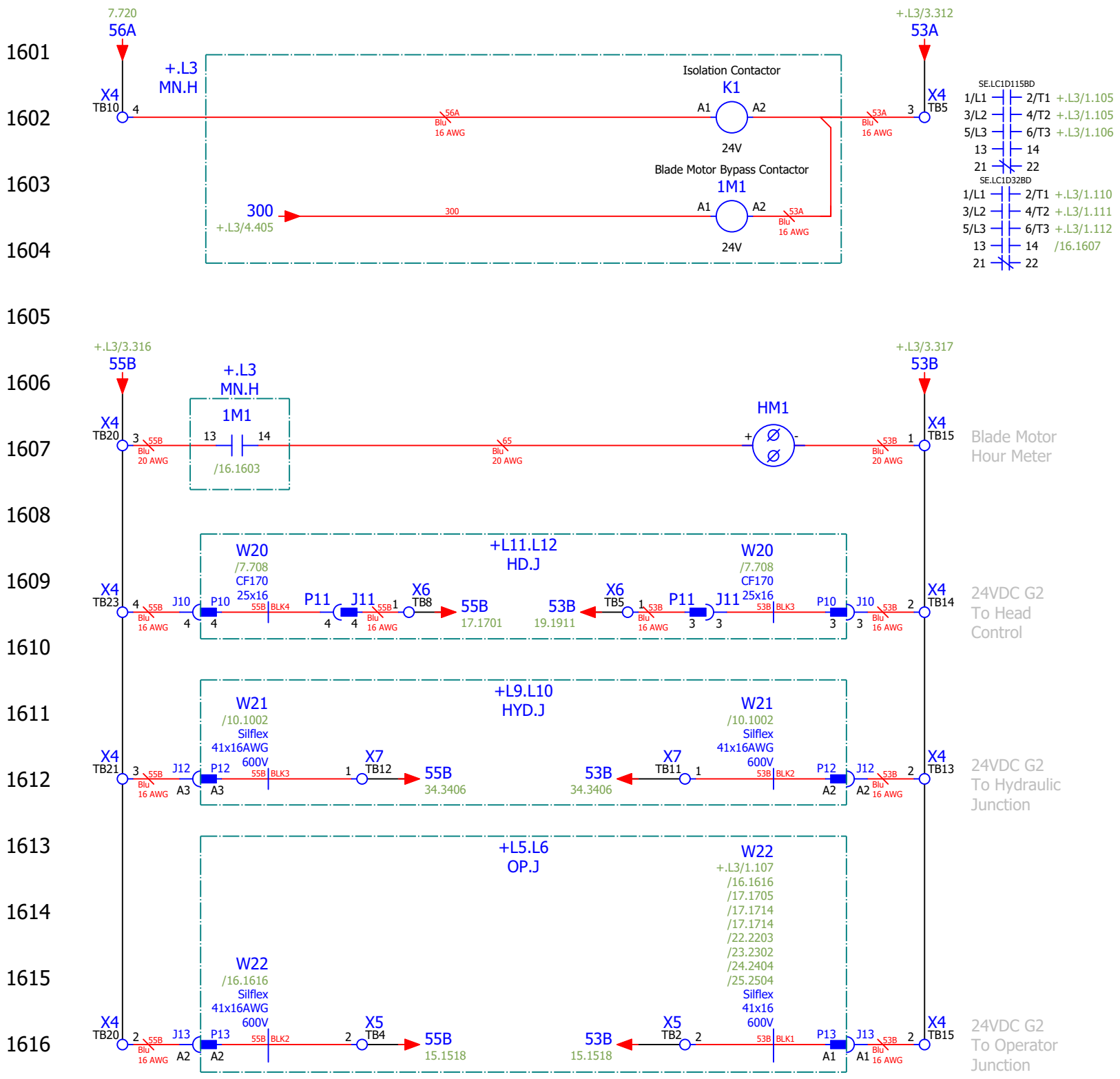

- SE.LC1D115BD
- 1/L1 --- 2/T1 +.L3/1.105
 - 3/L2 --- 4/T2 +.L3/1.105
 - 5/L3 --- 6/T3 +.L3/1.106
 - 13 --- 14
 - 21 --- 22
- SE.LC1D32BD
- 1/L1 --- 2/T1 +.L3/1.110
 - 3/L2 --- 4/T2 +.L3/1.111
 - 5/L3 --- 6/T3 +.L3/1.112
 - 13 --- 14 /16.1607
 - 21 --- 22

Blade Motor Hour Meter

24VDC G2 To Head Control

24VDC G2 To Hydraulic Junction

24VDC G2 To Operator Junction

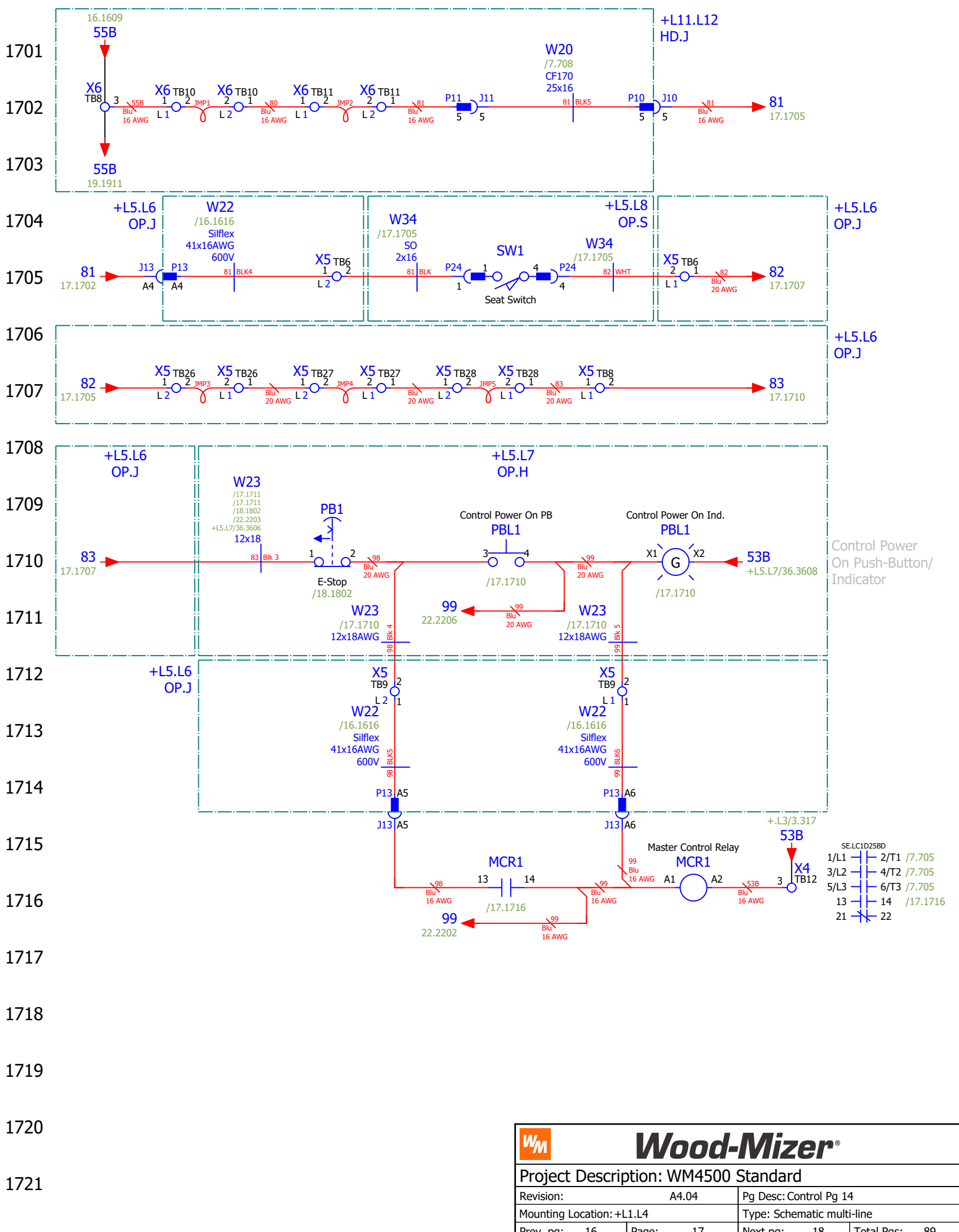

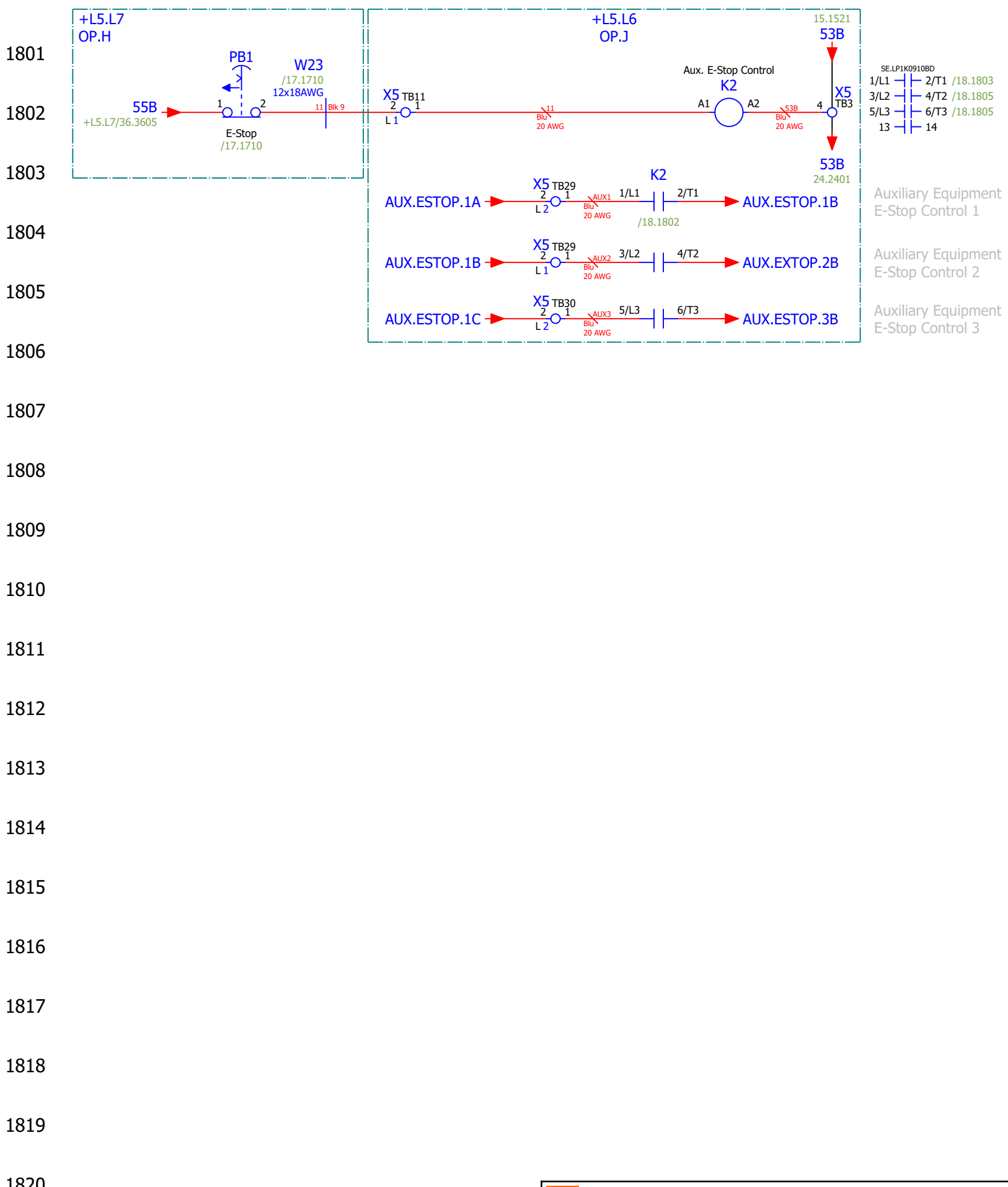

1801
1802
1803
1804
1805
1806
1807
1808
1809
1810
1811
1812
1813
1814
1815
1816
1817
1818
1819
1820
1821

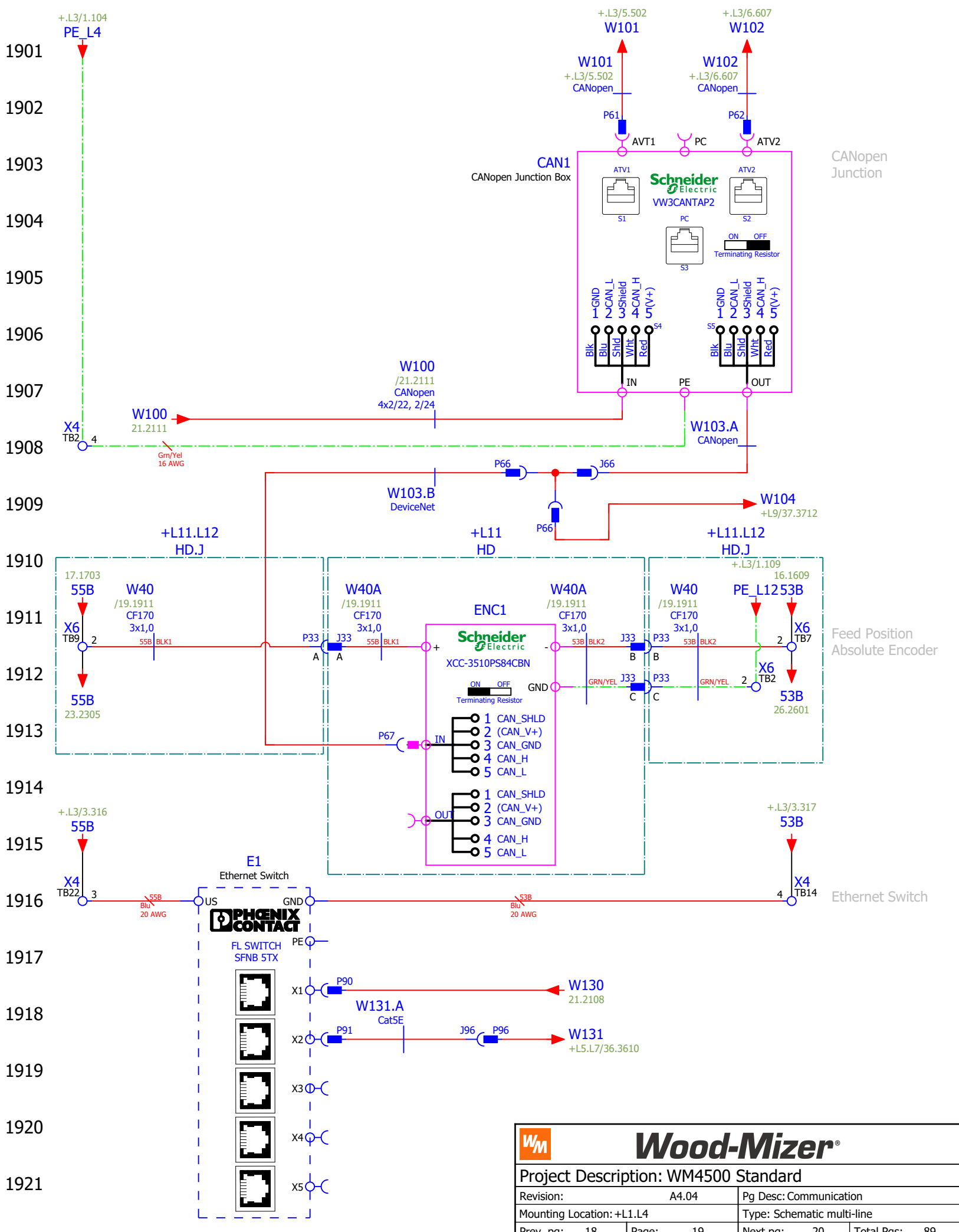

PLC1.7

PLC1.6

PLC1.5

PLC1.4

PLC1.3

PLC1.2

PLC1.1

PLC1

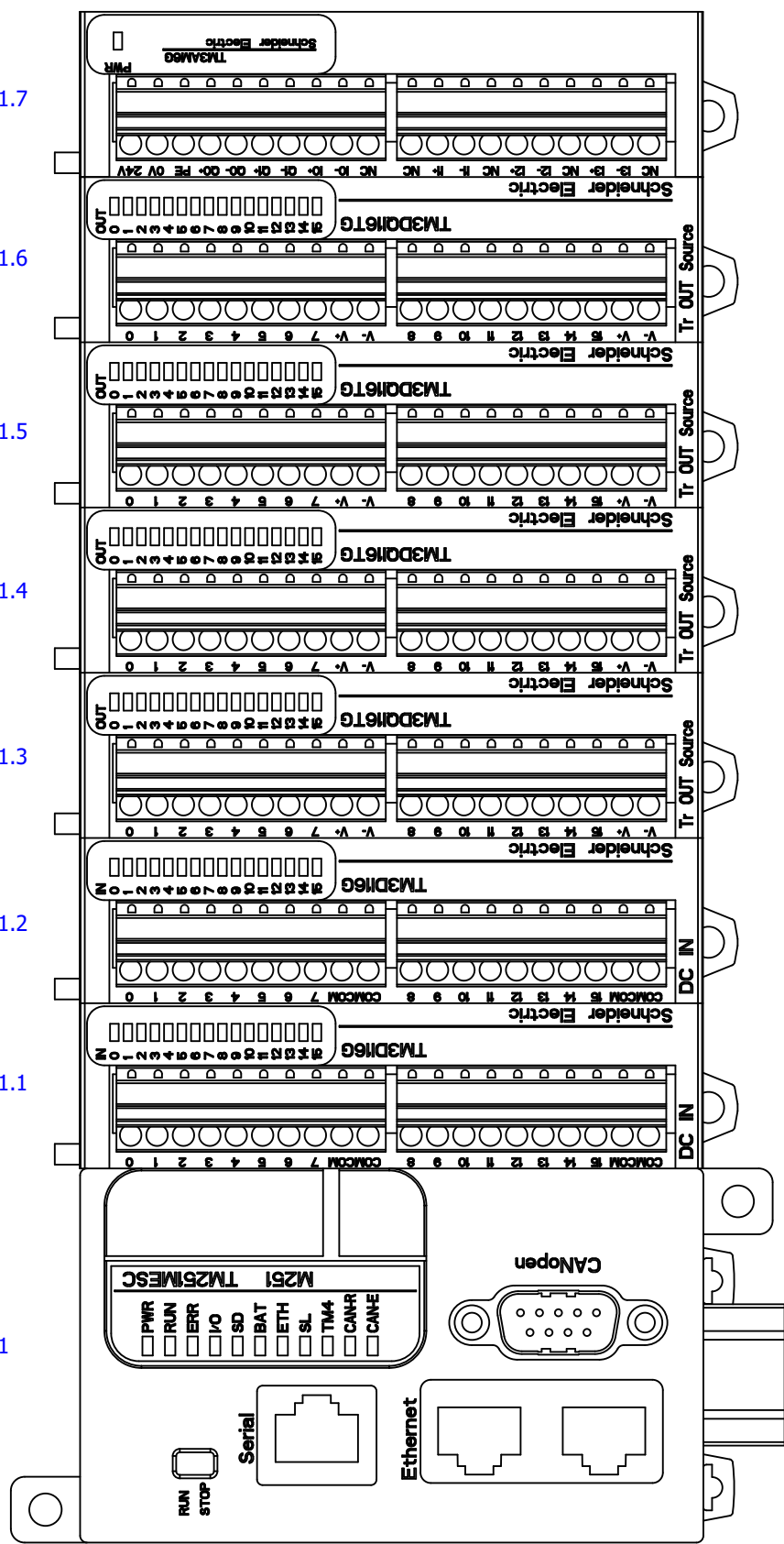

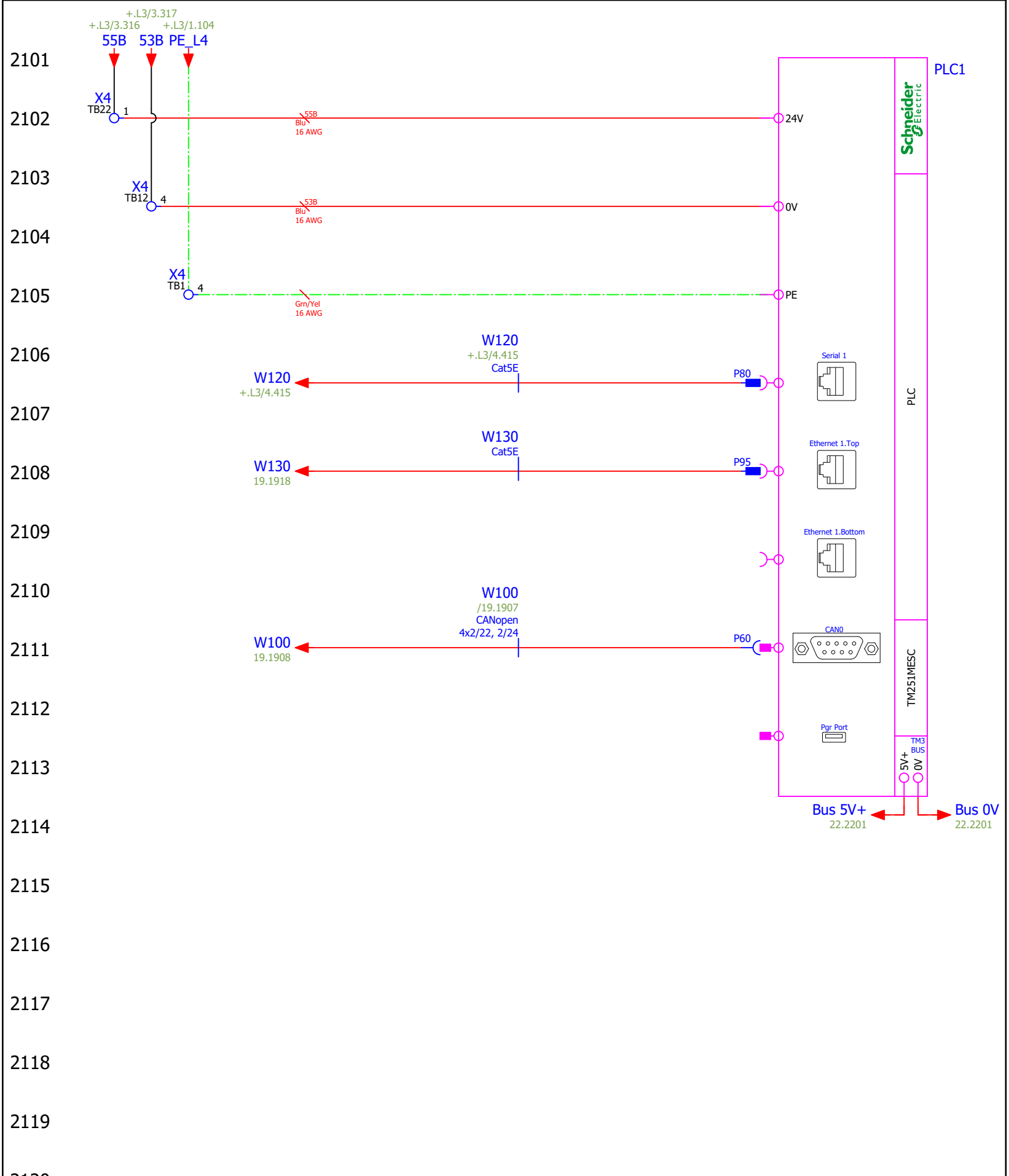

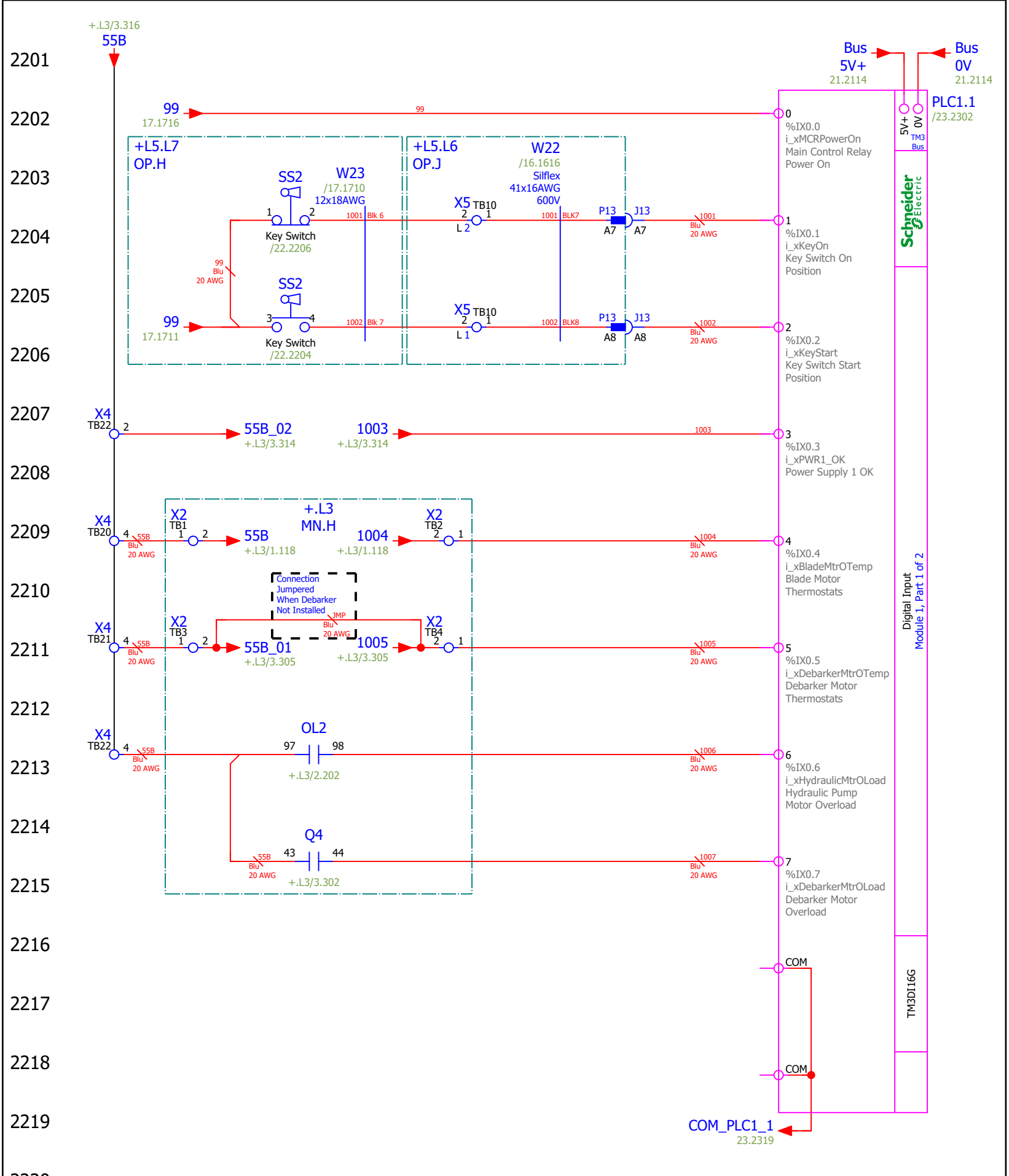

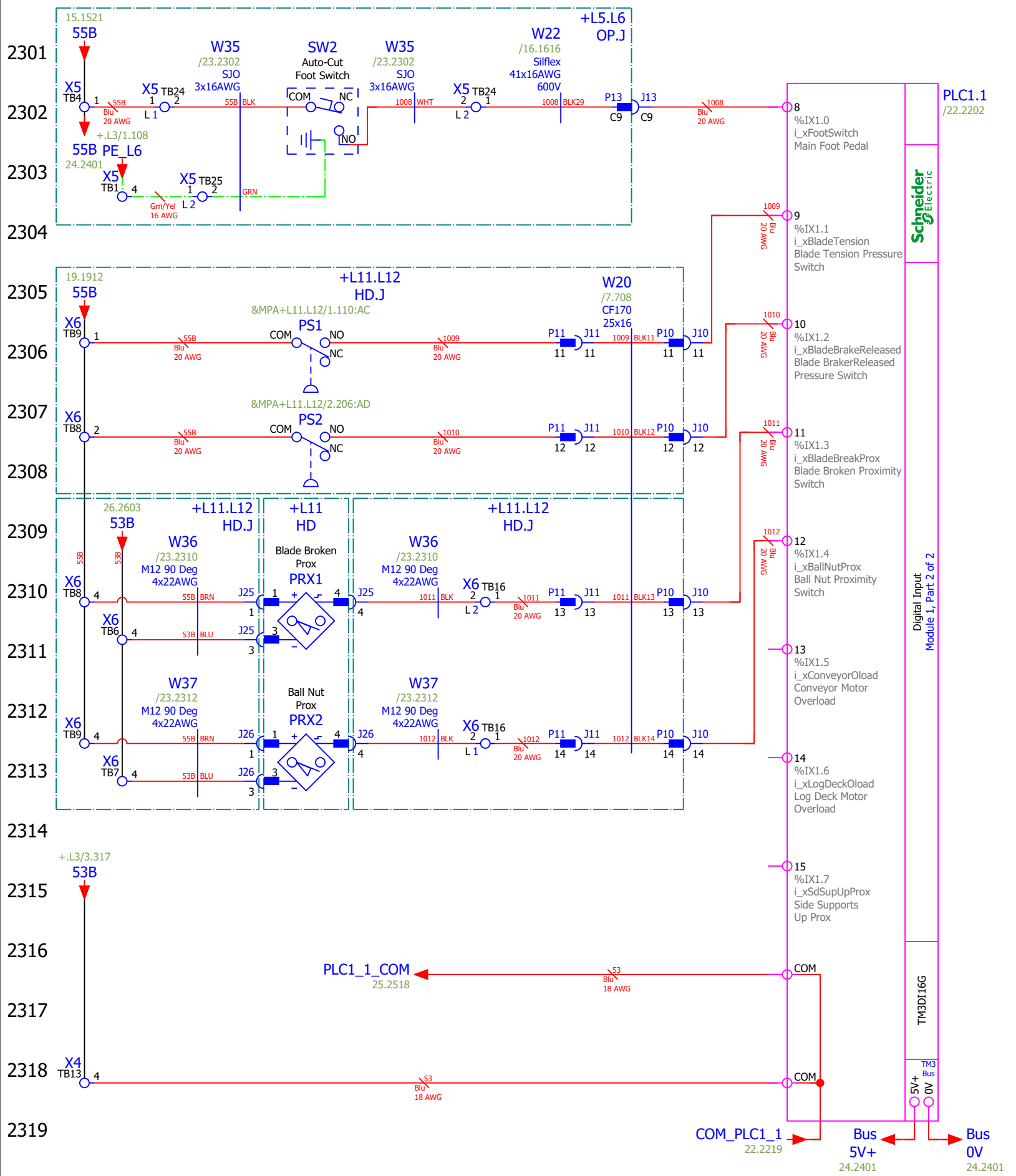

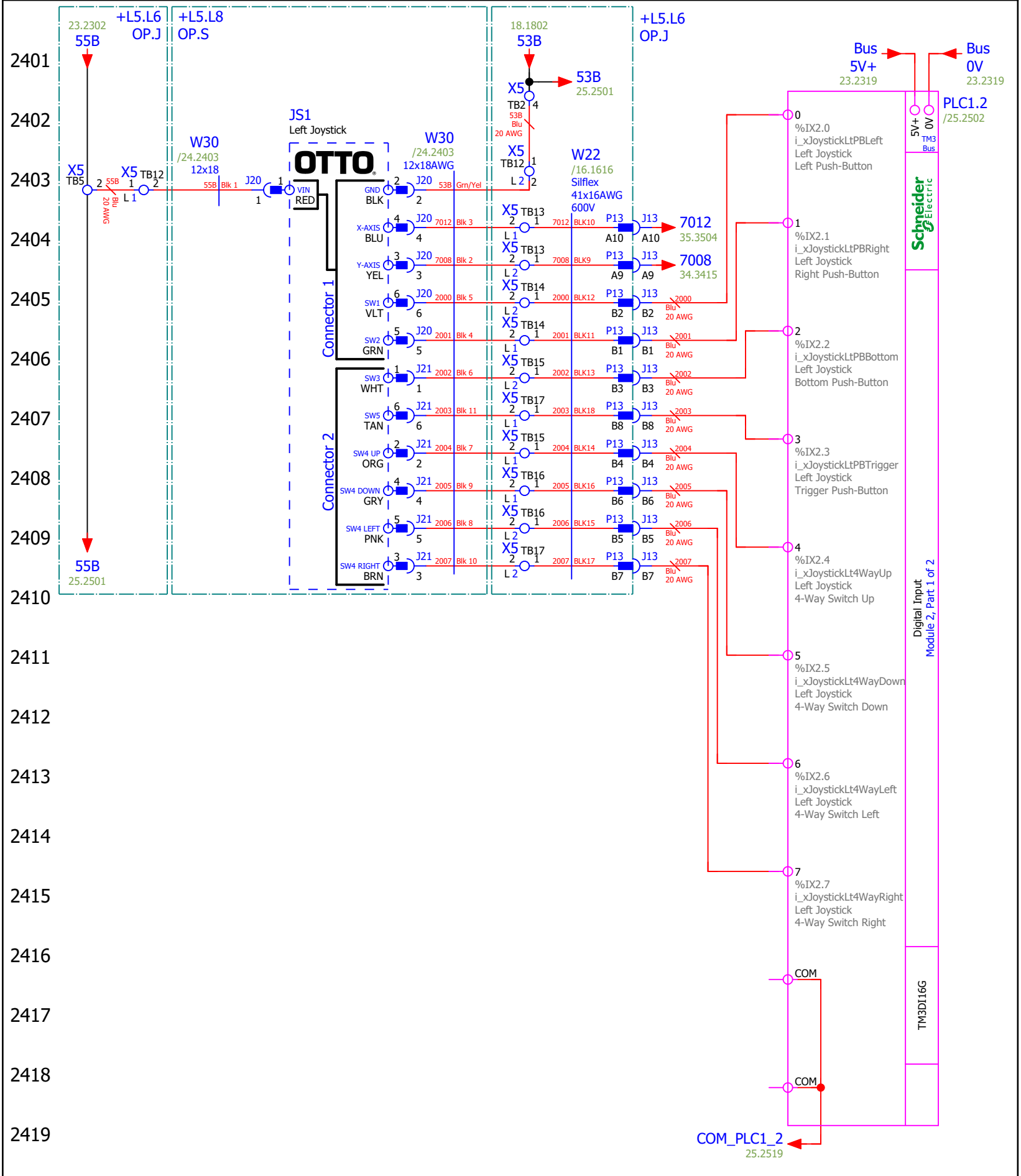

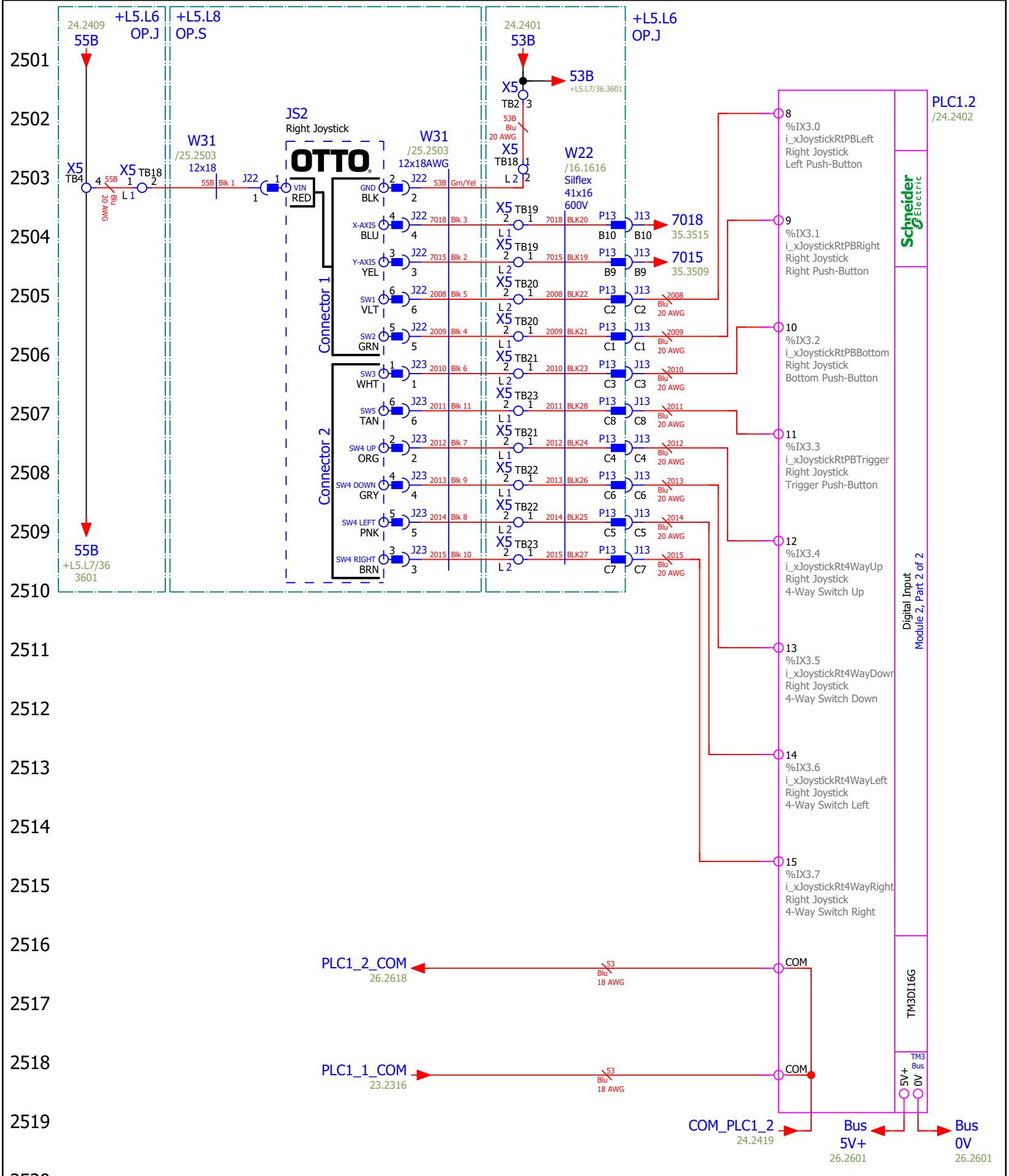

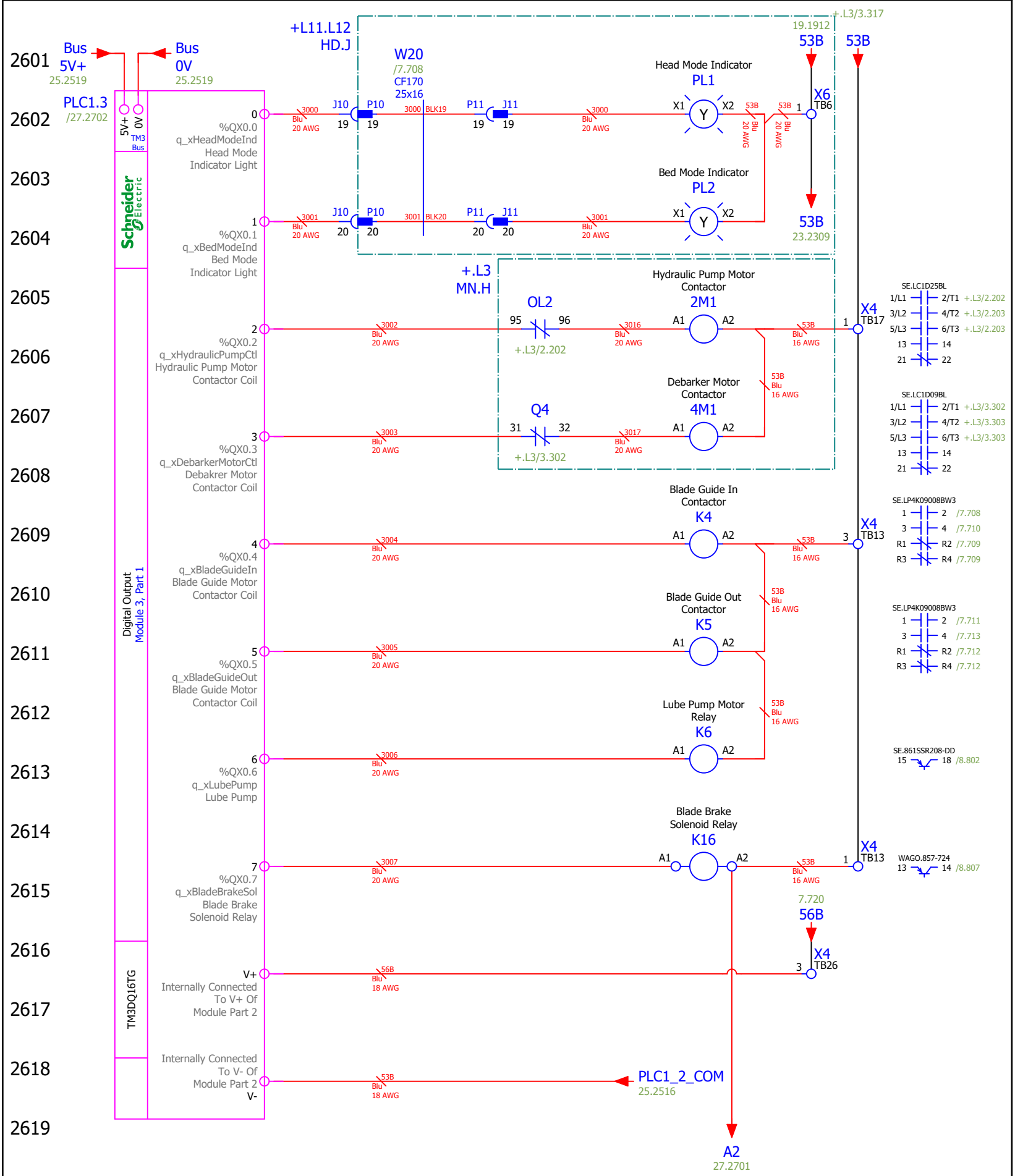



 Wood-Mizer®			
Project Description: WM4500 Standard			
Revision:	A4.04	Pg Desc:	PLC 6
Mounting Location:	+L1.L4	Type:	Schematic multi-line
Prev. pg:	25	Page:	26
		Next pg:	27
		Total Pgs:	89

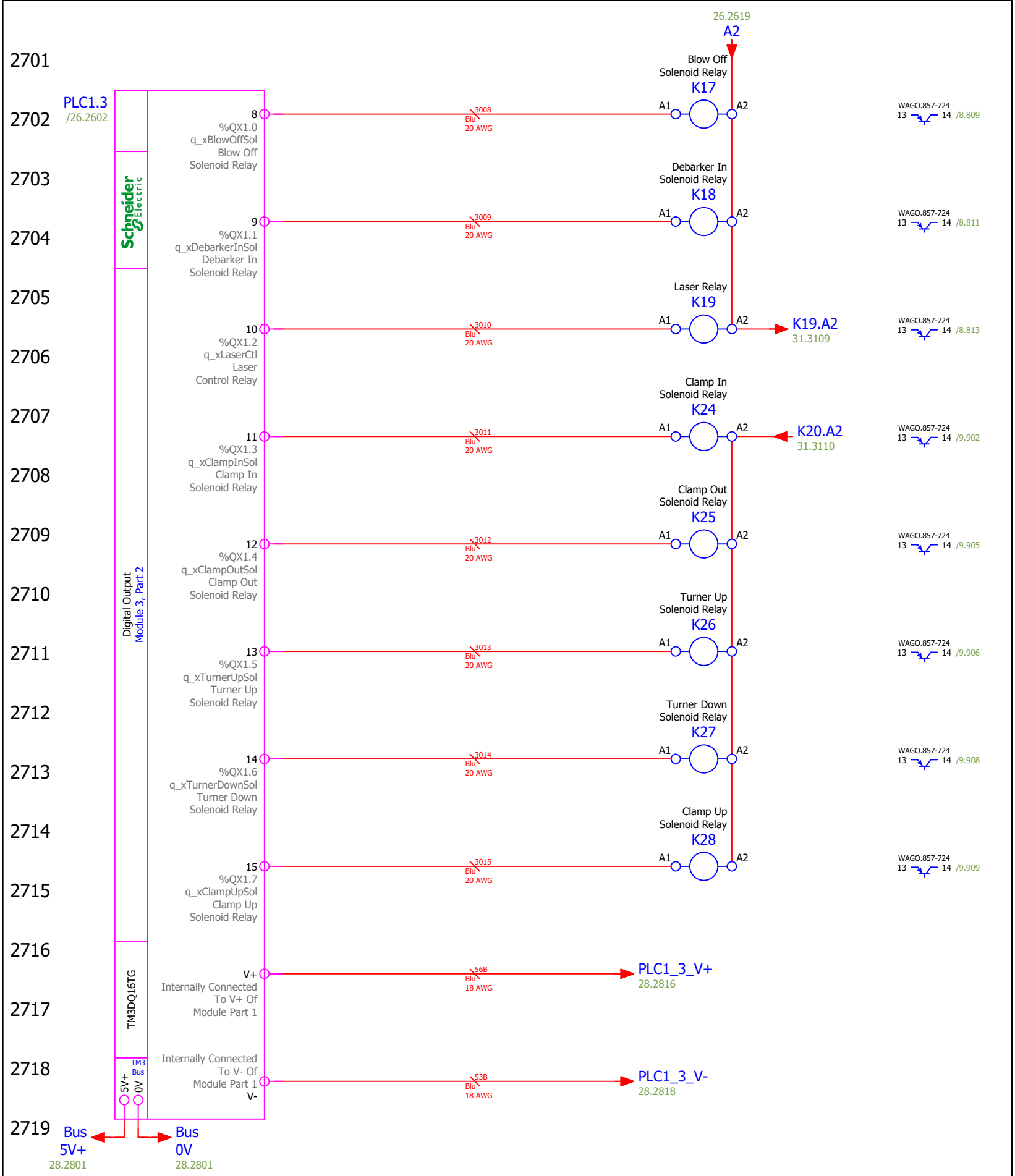

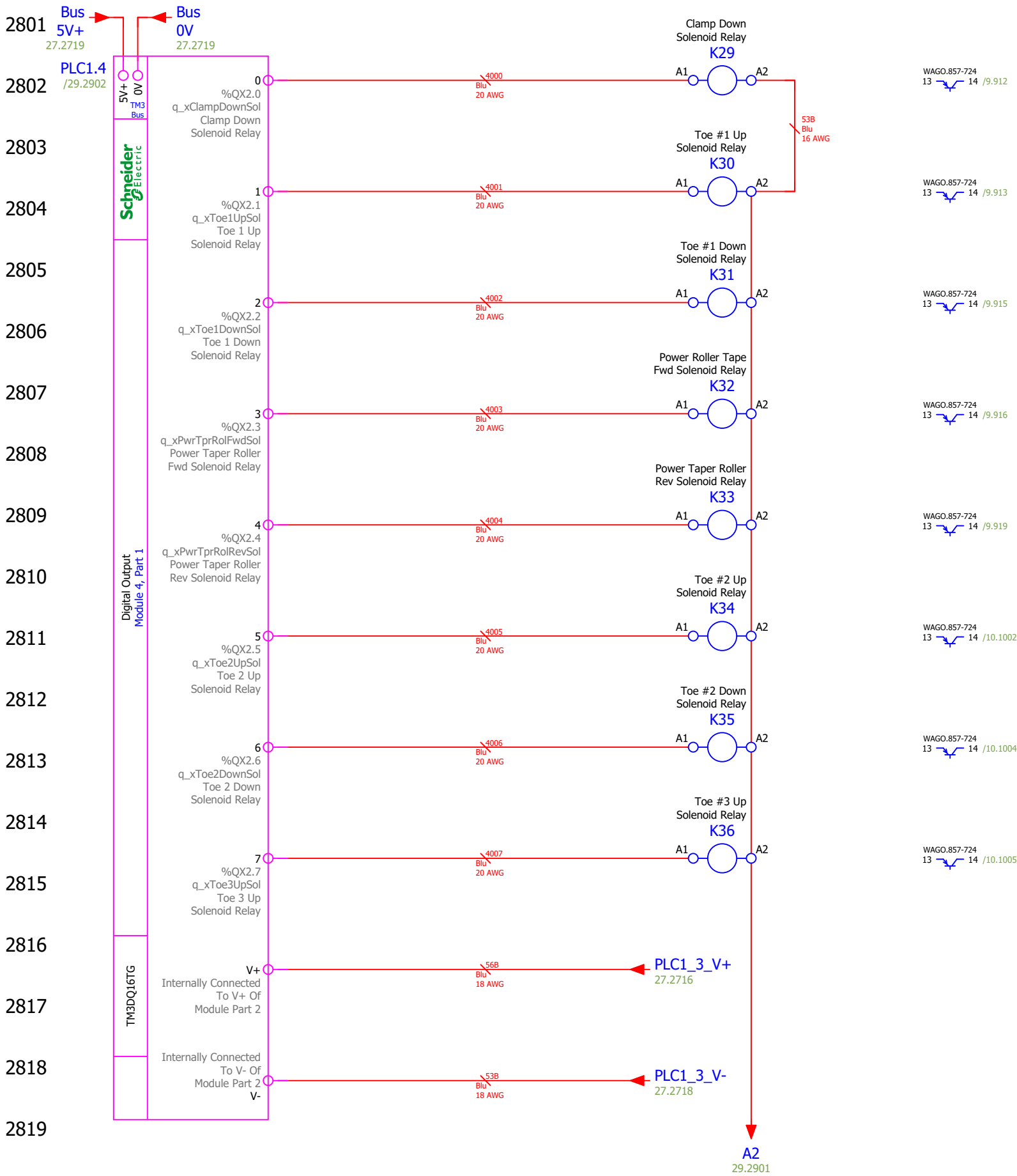

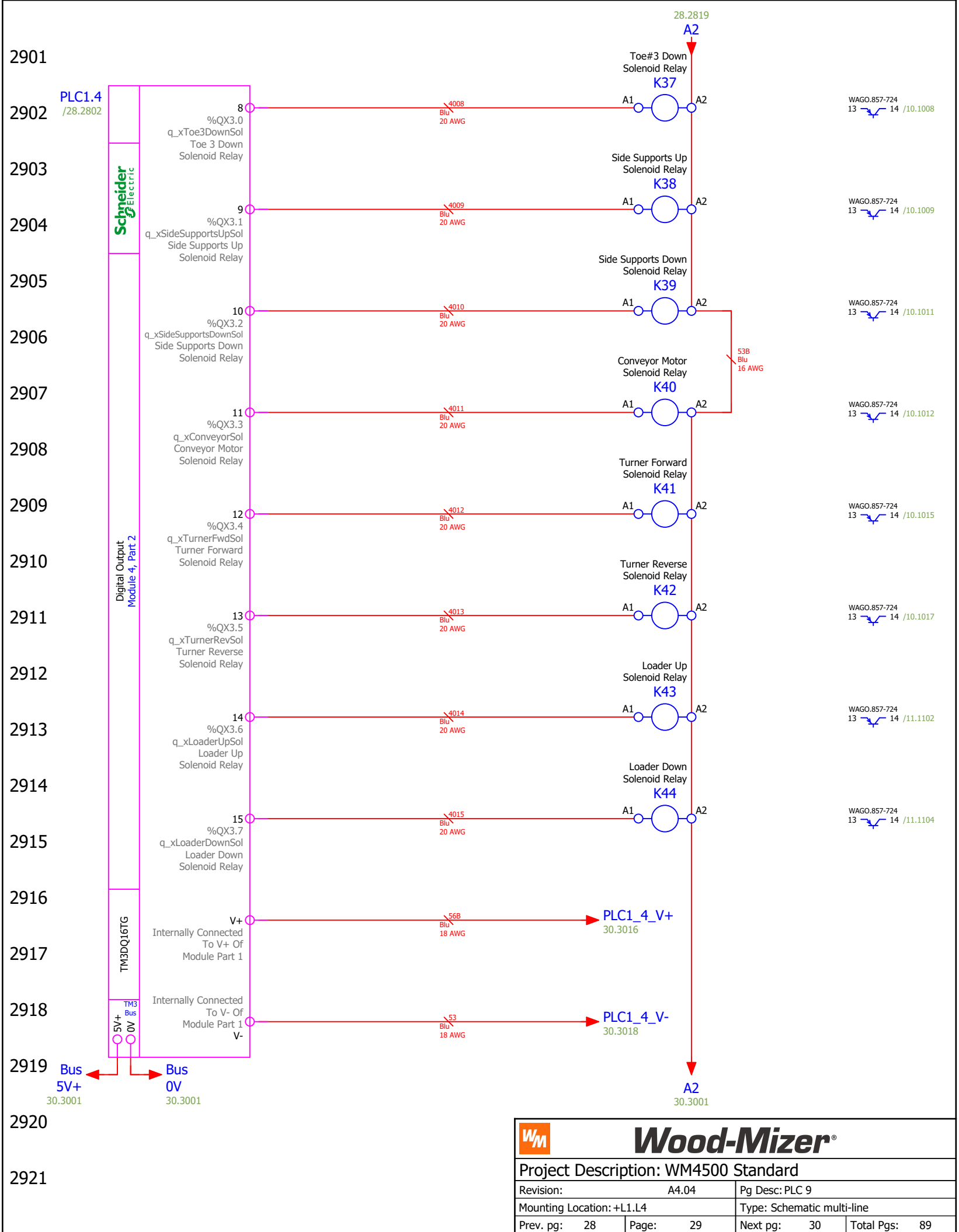

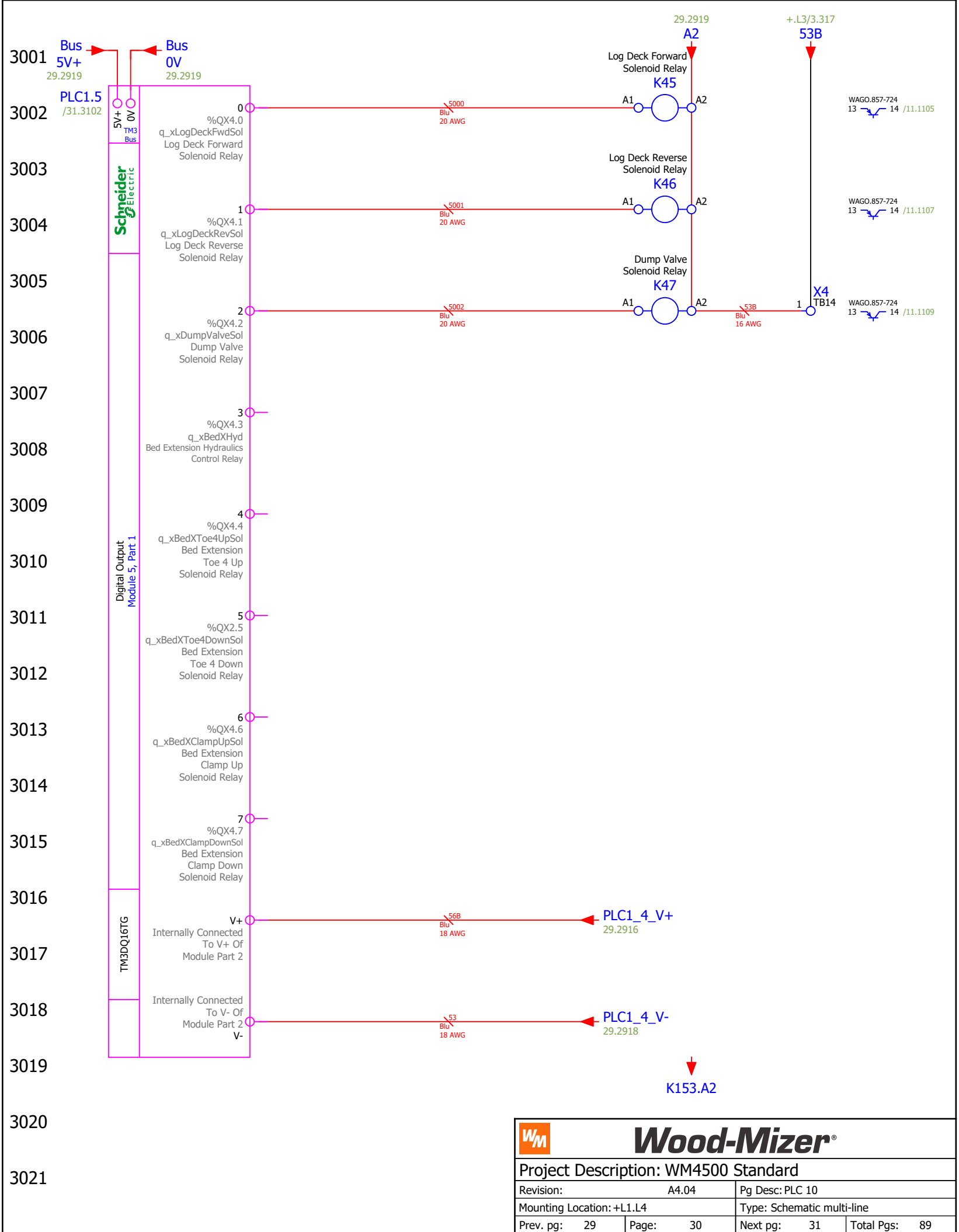

3101
3102
3103
3104
3105
3106
3107
3108
3109
3110
3111
3112
3113
3114
3115
3116
3117
3118
3119
3120
3121

PLC1.5
/30.3002



Digital Output
Module 5, Part 2

TM3DQ16TG

5V+
0V

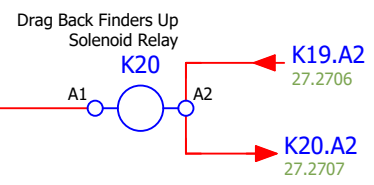
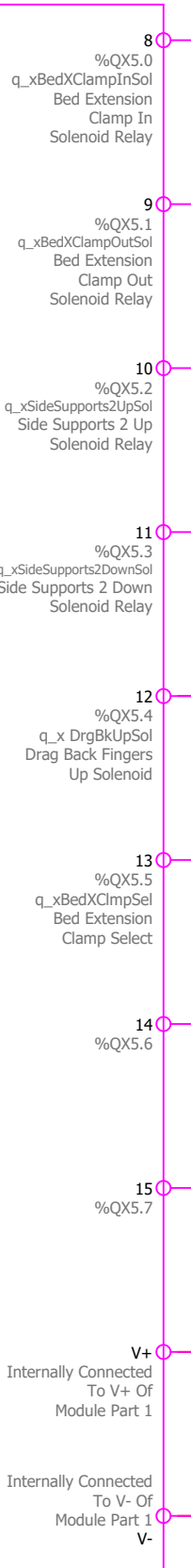

WAGO.857-724
13 14 /8.816

5012
Blu
20 AWG

56B
Blu
18 AWG

53
Blu
18 AWG

PLC1_5_V+
32.3216

PLC1_5_V-
32.3218

Bus 5V+
32.3201

Bus 0V
32.3201

		Wood-Mizer®	
Project Description: WM4500 Standard			
Revision:	A4.04	Pg Desc:	PLC 11
Mounting Location:	+L1.L4	Type:	Schematic multi-line
Prev. pg:	30	Page:	31
		Next pg:	32
		Total Pgs:	89

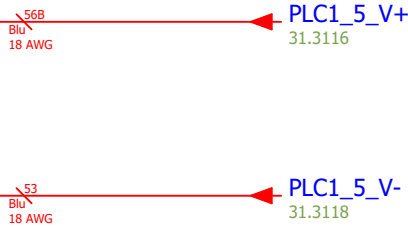
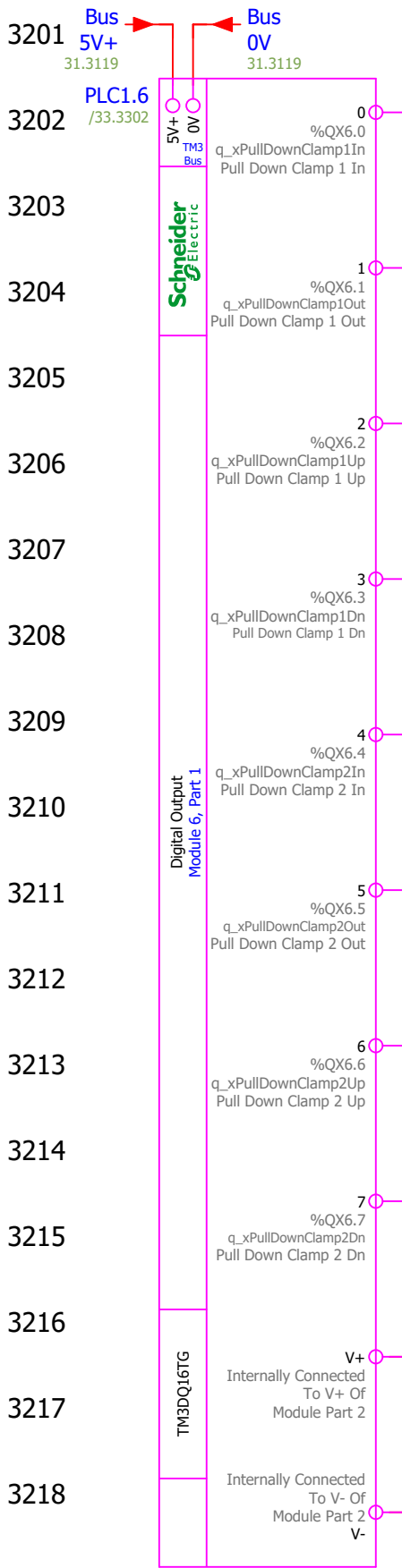

3301
3302
3303
3304
3305
3306
3307
3308
3309
3310
3311
3312
3313
3314
3315
3316
3317
3318
3319
3320
3321

PLC1.6
/32.3202



Digital Output
Module 6, Part 2

TM3DQ16TG

TM3 Bus

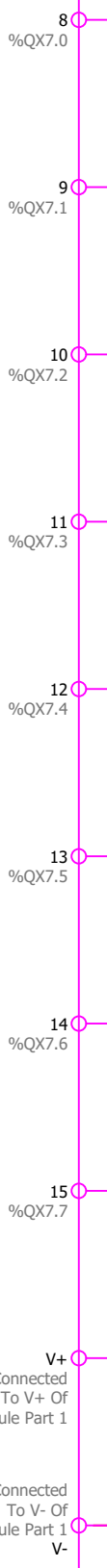

Bus 5V+ 34.3401
Bus 0V 34.3401

S3
Blu
18 AWG

PLC1_6_V-
34.3404

		Wood-Mizer®	
Project Description: WM4500 Standard			
Revision:	A4.04	Pg Desc:	PLC 13
Mounting Location:	+L1.L4	Type:	Schematic multi-line
Prev. pg:	32	Page:	33
		Next pg:	34
		Total Pgs:	89

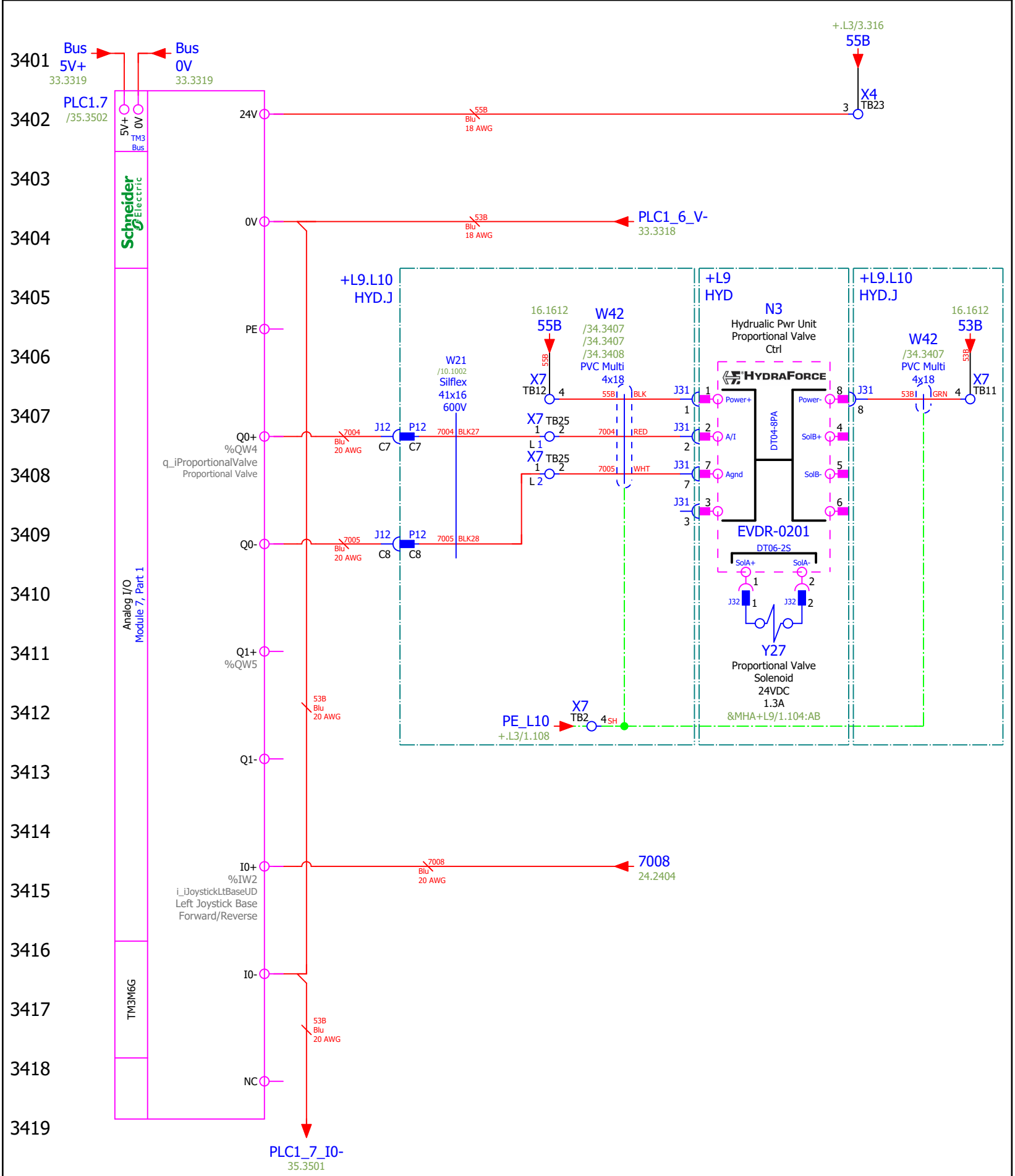

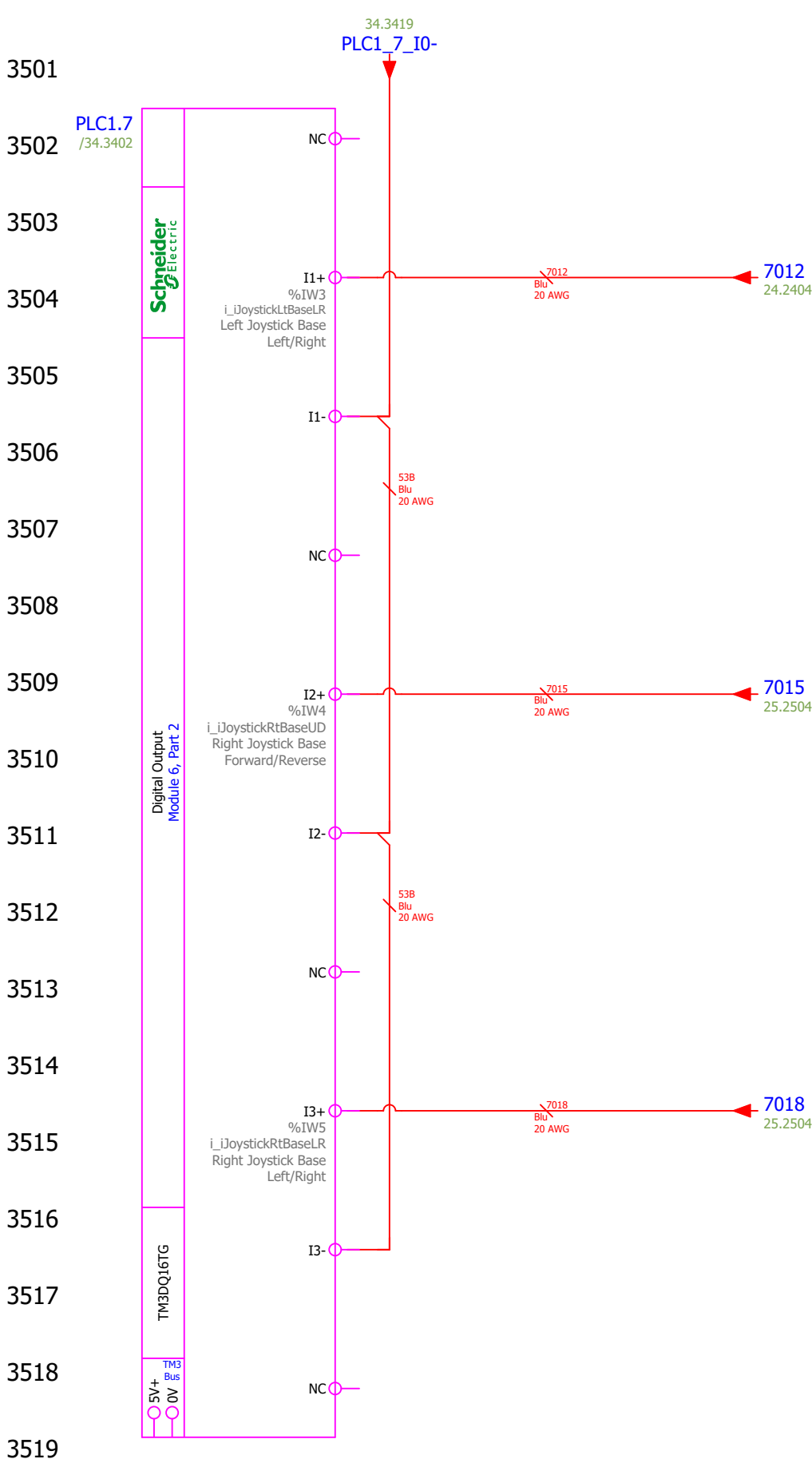

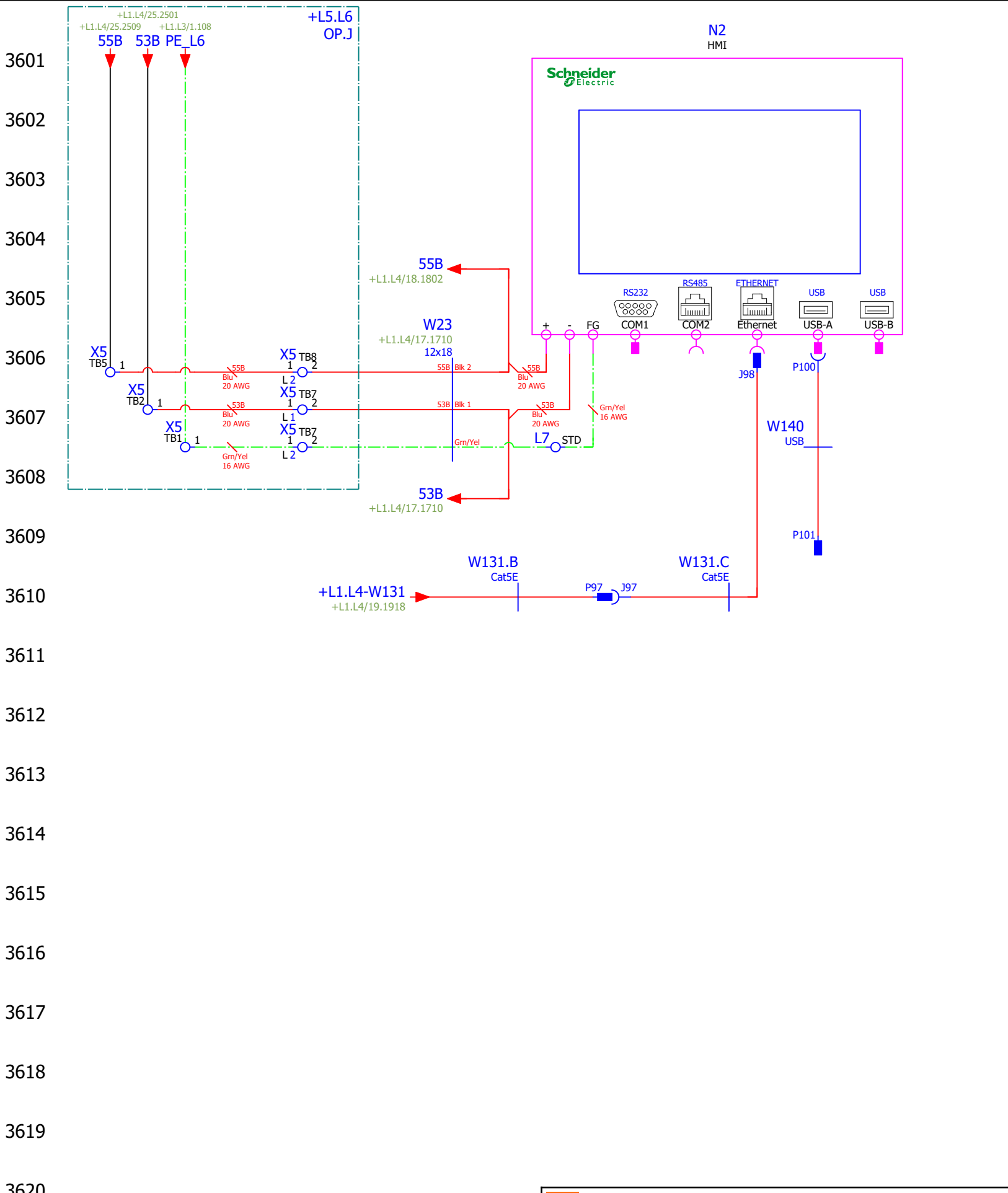

3601
3602
3603
3604
3605
3606
3607
3608
3609
3610
3611
3612
3613
3614
3615
3616
3617
3618
3619
3620
3621

3701
 3702
 3703
 3704
 3705
 3706
 3707
 3708
 3709
 3710
 3711
 3712
 3713
 3714
 3715
 3716
 3717
 3718
 3719
 3720
 3721

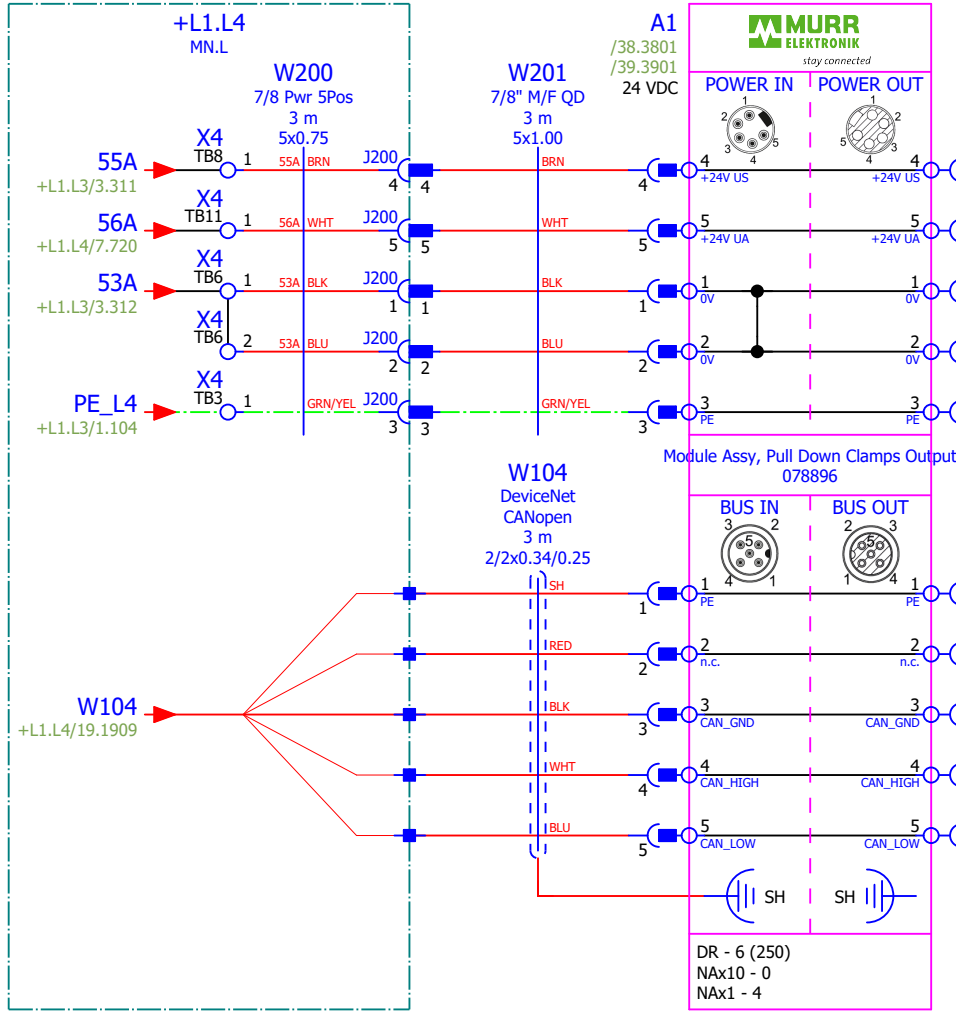

3801

3802 A1 /37.3705 24 VDC

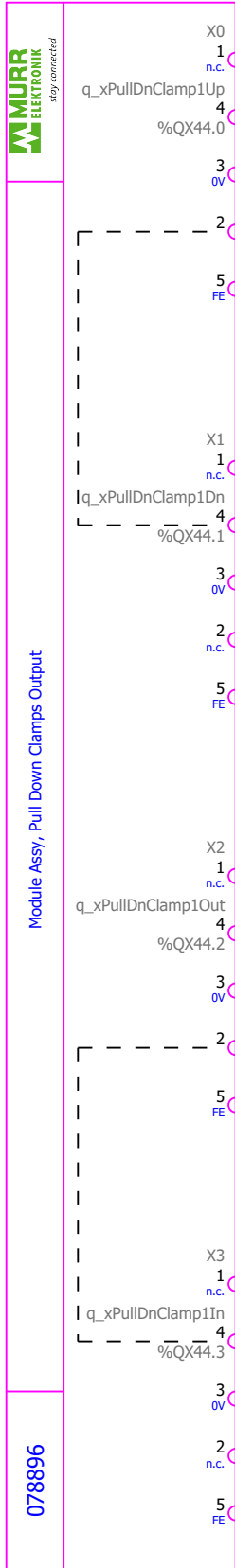

W80 Double Valve Form A/M12 1 m 4x0.75

&MHA/7.703:AA

Y30

x1 x2

Pull Down Clamp 1 Up

3803

3804

3805

3806

3807

3808

3809

3810

3811

3812

3813

3814

3815

3816

3817

3818

3819

3820

3821

W81 Double Valve Form A/M12 1 m 4x0.75

&MHA/7.705:AA

Y32

x1 x2

Pull Down Clamp 1 Out

PE

PE

PE

PE

PE

PE

PE

PE

PE

PE

PE

PE

PE

PE

PE

PE

PE

PE

PE

PE

PE

PE

PE

PE

PE

PE

PE



Wood-Mizer®

Project Description: WM4500 Standard

Revision:	A4.04	Pg Desc:	Pull Down Clamp 1
Mounting Location:	+L9	Type:	Schematic multi-line
Prev. pg:	37	Page:	38
		Next pg:	39
		Total Pgs:	89

3901

3902 A1
/37.3705
24 VDC

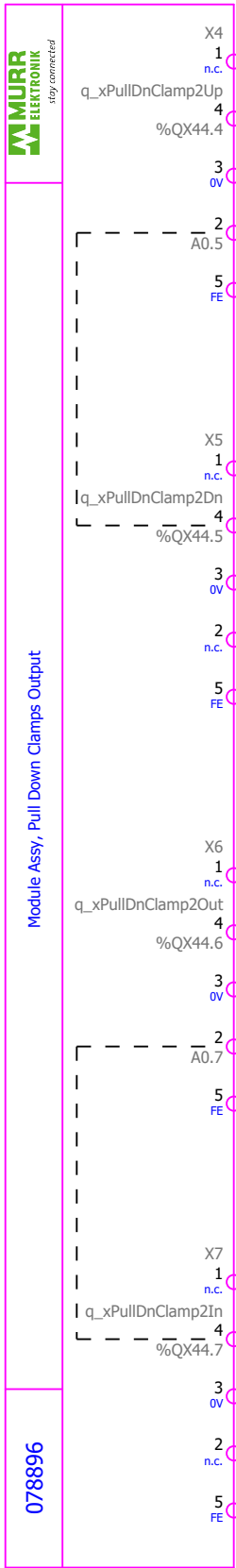

W82
Double Valve
Form A/M12
1 m
4x0.75

&MHA/7.707:AA

Y34

x1 x2

Pull Down
Clamp 2
Up

3903

3904

3905

3906

3907

3908

3909

3910

3911

3912

3913

3914

3915

3916

3917

3918

3919

3920

3921

W83
Double Valve
Form A/M12
1 m
4x0.75

&MHA/7.709:AA

Y36

x1 x2

Pull Down
Clamp 2
Up

&MHA/7.709:AB

Y37

x1 x2

Pull Down
Clamp 2
Down



Wood-Mizer®

Project Description: WM4500 Standard

Revision:	A4.04	Pg Desc:	Pull Down Clamp 2
Mounting Location:	+L9	Type:	Schematic multi-line
Prev. pg:	38	Page:	39
		Next pg:	+Docs/C1
		Total Pgs:	89

Device Tag/Parts List

WM_PARTS_LIST-Manual

Device tag	Function	Wood-Mizer Part Number	Wood-Mizer Description	Qty.	X-Ref
1M1	Blade Motor Bypass Contactor	052465	Contactor, 32A 3P 24VDC Coil	1	+L1.L4/16.1603
2M1	Hydraulic Pump Motor Contactor	069866	Contactor, 25A 3P 24V Low Pwr Coil	1	+L1.L4/26.2606
4M1	Debarker Motor Contactor	024890	Contactor, 9A 3P 24VDC Coil	1	+L1.L4/26.2607
A1	Pull Down Clamps Output Module	078896	Module Assy, Pull Down Clamps Output	1	+L9/37.3705
CAN1	CANopen Junction Box	069930	PLC Module, CANopen Junction	1	+L1.L4/19.1903
E1	Ethernet Switch	078466	Switch, Ethernet 5 Port 24VDC	1	+L1.L4/19.1916
ENC1	Feed Position Absolute Encoder	068046	Encoder Assy, Ind. Mill Feed	1	+L1.L4/19.1911
F4	Transformer L1&L3 Fuses	068066	Fuse Holder, 2P Class CC Wire Clamps	1	+L1.L3/3.307
F4	=	069915	Fuse, 0.25A 600V KLDR Class CC	2	+L1.L3/3.307
F5	Transformer Output Fuse	068065	Fuse Holder, 1P Class CC Wire Clamps	1	+L1.L3/3.308
F5	=	069915	Fuse, 0.25A 600V KLDR Class CC	1	+L1.L3/3.308
F6	Feed Drive L1 Fuse	053717	Fuseholder, 60A Cube	1	+L1.L3/2.208
F6	=	069702	Fuse, 40A Class J Cube	1	+L1.L3/2.208
F7	Feed Drive L2 Fuse	053717	Fuseholder, 60A Cube	1	+L1.L3/2.209
F7	=	069702	Fuse, 40A Class J Cube	1	+L1.L3/2.209
F8	Feed Drive L3 Fuse	053717	Fuseholder, 60A Cube	1	+L1.L3/2.209
F8	=	069702	Fuse, 40A Class J Cube	1	+L1.L3/2.209
F9	Power Supply 1 L1&L3 Fuses	068066	Fuse Holder, 2P Class CC Wire Clamps	1	+L1.L3/3.311
F9	=	052381	Fuse, 8A 600V Class CC Delay	2	+L1.L3/3.311
F10	Power Supply 2 L1&L3 Fuses	068066	Fuse Holder, 2P Class CC Wire Clamps	1	+L1.L3/3.316
F10	=	052713	Fuse, 4A 600V Class CC Delay	2	+L1.L3/3.316
F11	Hydraulic Pump Motor L1 Fuse	053736	Fuseholder, Cube 30A	1	+L1.L3/2.202
F11	=	053737	Fuse, 30A Class J Cube	1	+L1.L3/2.202
F12	Hydraulic Pump Motor L2 Fuse	053736	Fuseholder, Cube 30A	1	+L1.L3/2.203
F12	=	053737	Fuse, 30A Class J Cube	1	+L1.L3/2.203
F13	Hydraulic Pump Motor L3 Fuse	053736	Fuseholder, Cube 30A	1	+L1.L3/2.203
F13	=	053737	Fuse, 30A Class J Cube	1	+L1.L3/2.203
F14	Up/Down Servo Drive L1 Fuse	053736	Fuseholder, Cube 30A	1	+L1.L3/2.216
F14	=	053737	Fuse, 30A Class J Cube	1	+L1.L3/2.216
F15	Up/Down Servo Drive L2 Fuse	053736	Fuseholder, Cube 30A	1	+L1.L3/2.217
F15	=	053737	Fuse, 30A Class J Cube	1	+L1.L3/2.217
F16	Up/Down Servo Drive L3 Fuse	053736	Fuseholder, Cube 30A	1	+L1.L3/2.218
F16	=	053737	Fuse, 30A Class J Cube	1	+L1.L3/2.218
F17	Blade Motor L1 Fuse	053586	Fuseholder, 100A Cube	1	+L1.L3/1.117
F17	=	069708	Fuse, 60A Class J Cube	1	+L1.L3/1.117
F18	Blade Motor L2 Fuse	053586	Fuseholder, 100A Cube	1	+L1.L3/1.116
F18	=	069708	Fuse, 60A Class J Cube	1	+L1.L3/1.116
F19	Blade Motor L3 Fuse	053586	Fuseholder, 100A Cube	1	+L1.L3/1.116
F19	=	069708	Fuse, 60A Class J Cube	1	+L1.L3/1.116
G1	DC Motor/ Solenoids Power Supply	078012	Power Supply, 24VDC 20A 200-500V	1	+L1.L3/3.310
G2	Control Power Supply	078193	Power Supply, 24VDC 10A 200-500V	1	+L1.L3/3.315
HM1	Blade Motor Hour Meter	P09631	Meter, Hour	1	+L1.L4/16.1607
JS1	Left Joystick	078360	Joystick, 4-Button w/4-Way Switch	1	+L1.L4/24.2402
JS2	Right Joystick	078360	Joystick, 4-Button w/4-Way Switch	1	+L1.L4/25.2502
K1	Isolation Contactor	069886	Contactor, 115A 3P 24VDC Coil	1	+L1.L4/16.1602
K2	Aux. E-Stop Control	101241	Contactor, 9A 3P 24VDC 1NO	1	+L1.L4/18.1802
K4	Blade Guide In Contactor	024910	Contactor, 9A 2NC 2NO 24VDC Reversing	1	+L1.L4/26.2609
K5	Blade Guide Out Contactor	024910	Contactor, 9A 2NC 2NO 24VDC Reversing	1	+L1.L4/26.2611
K6	Lube Pump Motor Relay	069943	Relay, Solid State 8A DIN	1	+L1.L4/26.2613
K16	Blade Brake Solenoid Relay	068212	Relay, Solid State 2A 24VDC Coil Cage Clamp Base	1	+L1.L4/26.2615
K17	Blow Off Solenoid Relay	068212	Relay, Solid State 2A 24VDC Coil Cage Clamp Base	1	+L1.L4/27.2702
K18	Debarker In Solenoid Relay	068212	Relay, Solid State 2A 24VDC Coil Cage Clamp Base	1	+L1.L4/27.2704
K19	Laser Relay	068212	Relay, Solid State 2A 24VDC Coil Cage Clamp Base	1	+L1.L4/27.2706
K20	Drag Back Finders Up Solenoid Relay	068212	Relay, Solid State 2A 24VDC Coil Cage Clamp Base	1	+L1.L4/31.3109
K24	Clamp In Solenoid Relay	068212	Relay, Solid State 2A 24VDC Coil Cage Clamp Base	1	+L1.L4/27.2707
K25	Clamp Out Solenoid Relay	068212	Relay, Solid State 2A 24VDC Coil Cage Clamp Base	1	+L1.L4/27.2709
K26	Turner Up Solenoid Relay	068212	Relay, Solid State 2A 24VDC Coil Cage Clamp Base	1	+L1.L4/27.2711

		Wood-Mizer®	
Project Description: WM4500 Standard			
Revision:	A4.04	Pg Desc: Parts list	
Mounting Location:	+Docs	Type: Parts list	
Prev. pg:	+L9/39	Page:	C1
		Next pg:	C2
		Total Pgs:	89

Device Tag/Parts List

WM_PARTS_LIST-Manual

Device tag	Function	Wood-Mizer Part Number	Wood-Mizer Description	Qty.	X-Ref
K27	Turner Down Solenoid Relay	068212	Relay, Solid State 2A 24VDC Coil Cage Clamp Base	1	+L1.L4/27.2713
K28	Clamp Up Solenoid Relay	068212	Relay, Solid State 2A 24VDC Coil Cage Clamp Base	1	+L1.L4/27.2715
K29	Clamp Down Solenoid Relay	068212	Relay, Solid State 2A 24VDC Coil Cage Clamp Base	1	+L1.L4/28.2802
K30	Toe #1 Up Solenoid Relay	068212	Relay, Solid State 2A 24VDC Coil Cage Clamp Base	1	+L1.L4/28.2804
K31	Toe #1 Down Solenoid Relay	068212	Relay, Solid State 2A 24VDC Coil Cage Clamp Base	1	+L1.L4/28.2806
K32	Power Roller Tape Fwd Solenoid Relay	068212	Relay, Solid State 2A 24VDC Coil Cage Clamp Base	1	+L1.L4/28.2807
K33	Power Taper Roller Rev Solenoid Relay	068212	Relay, Solid State 2A 24VDC Coil Cage Clamp Base	1	+L1.L4/28.2809
K34	Toe #2 Up Solenoid Relay	068212	Relay, Solid State 2A 24VDC Coil Cage Clamp Base	1	+L1.L4/28.2811
K35	Toe #2 Down Solenoid Relay	068212	Relay, Solid State 2A 24VDC Coil Cage Clamp Base	1	+L1.L4/28.2813
K36	Toe #3 Up Solenoid Relay	068212	Relay, Solid State 2A 24VDC Coil Cage Clamp Base	1	+L1.L4/28.2815
K37	Toe#3 Down Solenoid Relay	068212	Relay, Solid State 2A 24VDC Coil Cage Clamp Base	1	+L1.L4/29.2902
K38	Side Supports Up Solenoid Relay	068212	Relay, Solid State 2A 24VDC Coil Cage Clamp Base	1	+L1.L4/29.2904
K39	Side Supports Down Solenoid Relay	068212	Relay, Solid State 2A 24VDC Coil Cage Clamp Base	1	+L1.L4/29.2906
K40	Conveyor Motor Solenoid Relay	068212	Relay, Solid State 2A 24VDC Coil Cage Clamp Base	1	+L1.L4/29.2907
K41	Turner Forward Solenoid Relay	068212	Relay, Solid State 2A 24VDC Coil Cage Clamp Base	1	+L1.L4/29.2909
K42	Turner Reverse Solenoid Relay	068212	Relay, Solid State 2A 24VDC Coil Cage Clamp Base	1	+L1.L4/29.2911
K43	Loader Up Solenoid Relay	068212	Relay, Solid State 2A 24VDC Coil Cage Clamp Base	1	+L1.L4/29.2913
K44	Loader Down Solenoid Relay	068212	Relay, Solid State 2A 24VDC Coil Cage Clamp Base	1	+L1.L4/29.2915
K45	Log Deck Forward Solenoid Relay	068212	Relay, Solid State 2A 24VDC Coil Cage Clamp Base	1	+L1.L4/30.3002
K46	Log Deck Reverse Solenoid Relay	068212	Relay, Solid State 2A 24VDC Coil Cage Clamp Base	1	+L1.L4/30.3004
K47	Dump Valve Solenoid Relay	068212	Relay, Solid State 2A 24VDC Coil Cage Clamp Base	1	+L1.L4/30.3006
LAS1	Laser	068035	Laser, 5mW 532nm 90 Deg Line Z-Laser Grn	1	+L1.L4/8.813
M1	Blade Motor	042301	Motor, 30HP 1800RPM	1	+L1.L3/1.115
M2	Hydraulic Pump Motor	078670	Motor, 15HP 230/460 3PH 60Hz	1	+L1.L3/2.202
M3	Feed Motor	115152	Motor, 5HP 3P 230/460 184TC	1	+L1.L3/2.208
M4	Up/Down Servo Motor	068038	Motor, Servo 100mm IP54 Encoder	1	+L1.L3/2.213
M5	Debarker Motor	050292	Motor, 3/4HP 230/460 3P 1725RPM DB LT60	1	+L1.L3/3.302
M6	Blade Guide Motor	035659	Motor Assy, 24V 60 RPM Gear	1	+L1.L4/7.716
MCR1	Master Control Relay	051322	Contact, 25A 3P 24VDC Coil	1	+L1.L4/17.1716
N2	HMI	078794	HMI Assy, Ind. Mill	1	+L5.L7/36.3601
N3	Hydraulic Pwr Unit Proportional Valve Ctrl	068277	Driver Assy, Prop Valve 8 Pin A2.00+	1	+L1.L4/34.3406
OL2	Hydraulic Pump Motor Overload	069885	Overload, 16-24A Class 10 Single Ph Sens	1	+L1.L3/2.202
PB1	E-Stop	068940	Pushbutton Head, 22mm E-Stop Twist-Pull	1	+L1.L4/17.1710
PB1	=	068950	Collar, Mount 1NC ZB5	1	+L1.L4/17.1710
PB1	=	068921	Contact Block, NC ZB5	1	+L1.L4/17.1710
PB2	Blade Brake Manual Override Push-Button	068950	Collar, Mount 1NC ZB5	1	+L1.L4/8.807
PB2	=	068920	Contact Block, NO ZB5	1	+L1.L4/8.807
PBL1	Control Power On PB	068952	Collar, Mount 1NO ZB5	1	+L1.L4/17.1710
PBL1	=	052503	Switch Head, PB Green Flush Illum ZB5	1	+L1.L4/17.1710
PBL1	=	068910	Light Module, Green ZB5	1	+L1.L4/17.1710
PL1	Head Mode Indicator	068912	Light Module, White ZB5	1	+L1.L4/26.2602
PL1	=	068931	Pilot Light, Yellow ZB5	1	+L1.L4/26.2602
PL1	=	068951	Switch Collar, Mount ZB5	1	+L1.L4/26.2602
PL2	Bed Mode Indicator	068912	Light Module, White ZB5	1	+L1.L4/26.2604
PL2	=	068931	Pilot Light, Yellow ZB5	1	+L1.L4/26.2604
PL2	=	068951	Switch Collar, Mount ZB5	1	+L1.L4/26.2604
PLC1	PLC	078783	PLC Assy, Ind. Mill M251	1	+L1.L4/21.2101
PLC1	=	078782	PLC Assy, Ind. Mill CPU	1	+L1.L4/21.2101
PLC1.1	Digital Input	078491	Input Module, Spring Clamp 16Pt Digital	1	+L1.L4/22.2202
PLC1.2	=	078491	Input Module, Spring Clamp 16Pt Digital	1	+L1.L4/24.2402
PLC1.3	Digital Output	078492	Output Module, TM3 16Pt. Transistor	1	+L1.L4/26.2602
PLC1.4	=	078492	Output Module, TM3 16Pt. Transistor	1	+L1.L4/28.2802
PLC1.5	=	078492	Output Module, TM3 16Pt. Transistor	1	+L1.L4/30.3002
PLC1.6	=	078492	Output Module, TM3 16Pt. Transistor	1	+L1.L4/32.3202
PLC1.7	Analog I/O	078648	Analog Module, TM3 4I/2O	1	+L1.L4/34.3402
PRX1	Blade Broken Prox	051439	Sensor, Ind Prox M12 PNP NS Ex	1	+L1.L4/23.2310
PRX2	Ball Nut Prox	051439	Sensor, Ind Prox M12 PNP NS Ex	1	+L1.L4/23.2313

		Wood-Mizer®	
Project Description: WM4500 Standard			
Revision:	A4.04	Pg Desc: Parts list	
Mounting Location:	+Docs	Type: Parts list	
Prev. pg:	C1	Page:	C2
Next pg:	C3	Total Pgs:	89

Device Tag/Parts List

Device tag	Function	Wood-Mizer Part Number	Wood-Mizer Description	Qty.	X-Ref
PS1	Blade Tension Pressure Switch	045207	Switch, Limit Pressure 60 PSI	1	+L1.L4/23.2306
PS2	Blade Brake Released Pressure Switch	045207	Switch, Limit Pressure 60 PSI	1	+L1.L4/23.2307
Q1	Main Disconnect	078506	Disconnect, 200A 3Ph Non-Fused	1	+L1.L3/1.101
Q2	Blade Guide Motor Breaker	051915	Breaker, 3A 1P MG24502	1	+L1.L4/7.708
Q3	Lube Pump Motor Breaker	051915	Breaker, 3A 1P MG24502	1	+L1.L4/8.802
Q4	Debarker Motor	068097	Motor Protector, 1.0-1.6 Manual	1	+L1.L3/3.302
Q4	=	068199	Motor Protector, Aux Contacts 1NO 1NC	1	+L1.L3/3.302
Q4	=	068098	Motor Protector, Line Side Barrier	1	+L1.L3/3.302
Q4	=	068099	Motor Protector, Interconnect LC1D09-25	1	+L1.L3/3.302
R1	Feed Drive Braking Resistor	078784	Resistor Assy, Ind. Mill Feed	1	+L1.L3/2.206
R2	Up/Down Drive Bracking Resistor	068161	Resistor Assy, Ind. Mill Up/Dn	1	+L1.L3/2.212
-R3	Modbus Network Terminating Resistor	112808	Resistor, Modbus Term. RJ45 120ohm	1	+L1.L3/4.416
SD1		078781	Drive Assy, Ind. Mill Up/Down	1	+L1.L3/2.211
SS2	Key Switch	068950	Collar, Mount 1NC ZB5	1	+L1.L4/22.2204
SS2	=	068920	Contact Block, NO ZB5	1	+L1.L4/22.2204
SS2	=	068941	Switch, Key 3Pos Mom R-C	1	+L1.L4/22.2204
SSD1	Blade Motor Soft-Start Power	069933-A1	Drive Assy, Ind. Mill Blade	1	+L1.L3/1.112
SW1	Seat Switch	069737	Switch, Seat 2 NO Contacts	1	+L1.L4/17.1705
SW2	Auto-Cut Foot Switch	052789	Switch, Foot Single Lever IP68	1	+L1.L4/23.2302
SW3	Secondary Side Supports Foot Switch	052789	Switch, Foot Single Lever IP68	1	+L1.L4/15.1513
T1	Soft-Start Control Transformer	069909	Transformer, 0.05kVA 240x480P 120/240S	1	+L1.L3/3.307
VFD1	Feed Drive Power	078780	Drive Assy, Ind. Mill Feed	1	+L1.L3/2.205
X1.1	1L1 Distribution Block	069908	Distribution Block, 1P 1in 4out 175A DIN	1	+L1.L3/3.305
X1.2	1L3 Distribution Block	069908	Distribution Block, 1P 1in 4out 175A DIN	1	+L1.L3/3.305
X1.3	2L1 Distribution Block	069801	Distribution Block, 1P 1in 6out 380A DIN	1	+L1.L3/1.107
X1.4	2L2 Distribution Block	069801	Distribution Block, 1P 1in 6out 380A DIN	1	+L1.L3/1.107
X1.5	2L3 Distribution Block	069801	Distribution Block, 1P 1in 6out 380A DIN	1	+L1.L3/1.107
X1.6	1L1 Distribution Block	069872	Distribution Block, 1P 2in 2out 620A DIN	1	+L1.L3/1.101
X1.7	1L3 Distribution Block	069872	Distribution Block, 1P 2in 2out 620A DIN	1	+L1.L3/1.103
X3.1	Ground Distribution Block	025203	Bar, Grounding 14 Circuit W/Lug	1	+L1.L3/1.107
Y27	Proportional Valve Solenoid	068258	Valve, Proportional Coil PV72-30A	1	+L1.L4/34.3411
Y29	Secondary Side Supports Up Diverter	078447	Coil, Series 12 DIN 24VFD EG	1	+L1.L4/15.1514
Y30	Secondary Side Supports Down Diverter	078447	Coil, Series 12 DIN 24VFD EG	1	+L1.L4/15.1516
Y50	Lube Solenoid	051432	Valve, Solenoid 1/4 NPT Water NC 2 Way	1	+L1.L4/8.802

 Wood-Mizer®	
Project Description: WM4500 Standard	
Revision: A4.04	Pg Desc: Parts list
Mounting Location: +Docs	Type: Parts list
Prev. pg: C2	Page: C3
Next pg: D1	Total Pgs: 89

Terminal line-up diagram

Terminal strip +L1.L3-X2

Terminal				Jumper		End Plate	Remark	Terminal X-Ref
Ref. Des.	Level	P/N	Description	Diagram	P/N	P/N		
TB1	0	068106	Terminal Block, 2Pos 4mm Clamp	⋮				&MEA+.L4/22.09
TB2	0	068106	Terminal Block, 2Pos 4mm Clamp	⋮		068108		&MEA+.L4/22.09
TB3	0	068106	Terminal Block, 2Pos 4mm Clamp	●				&MEA+.L4/22.11
TB4	0	068106	Terminal Block, 2Pos 4mm Clamp	●		068108		&MEA+.L4/22.11

Terminal line-up diagram

Terminal strip +L1.L4-X4

Terminal				Jumper		End Plate	Remark	Terminal X-Ref
Ref. Des.	Level	P/N	Description	Diagram	P/N	P/N		
TB1	0	068104	Terminal Block, 4Pos 1.5mm GND Clamp					&MEA+.L3/1.05
TB2	0	068104	Terminal Block, 4Pos 1.5mm GND Clamp					&MEA+.L3/1.05
TB3	0	068104	Terminal Block, 4Pos 1.5mm GND Clamp					&MEA+.L3/1
TB4	0	068103	Terminal Block, 4Pos 1.5mm Com Clamp	●	068113		Jumper is Trimmed Down To 3 Position Jumper Between TB4-6	&MEA+.L3/3.12
TB5	0	068103	Terminal Block, 4Pos 1.5mm Com Clamp	●				&MEA/12.18
TB6	0	068103	Terminal Block, 4Pos 1.5mm Com Clamp	●				&MEA/12
TB7	0	068103	Terminal Block, 4Pos 1.5mm Com Clamp	●	068113		Jumper is Trimmed Down To 2 Position Jumper Between TB7-8	&MEA+.L3/3.11
TB8	0	068103	Terminal Block, 4Pos 1.5mm Com Clamp	●		068105		&MEA+L9/37.06
TB9	0	068103	Terminal Block, 4Pos 1.5mm Com Clamp	●	068113		Jumper is Trimmed Down To 3 Position Jumper Between TB9-11	&MEA/7.06
TB10	0	068103	Terminal Block, 4Pos 1.5mm Com Clamp	●				&MEA/16.02
TB11	0	068103	Terminal Block, 4Pos 1.5mm Com Clamp	●		068105		&MEA+L9/37.07
TB12	0	068103	Terminal Block, 4Pos 1.5mm Com Clamp	●	068113		Jumper is Trimmed Down To 8 Position Between TB12-19	&MEA+.L3/3.17
TB13	0	068103	Terminal Block, 4Pos 1.5mm Com Clamp	●				&MEA/26.15
TB14	0	068103	Terminal Block, 4Pos 1.5mm Com Clamp	●				&MEA/30.06
TB15	0	068103	Terminal Block, 4Pos 1.5mm Com Clamp	●				&MEA/16.07
TB16	0	068103	Terminal Block, 4Pos 1.5mm Com Clamp	●				&MEA+.L3/6.06
TB17	0	068103	Terminal Block, 4Pos 1.5mm Com Clamp	●				&MEA/26.06
TB18	0	068103	Terminal Block, 4Pos 1.5mm Com Clamp	●				&MEA/7
TB19	0	068103	Terminal Block, 4Pos 1.5mm Com Clamp	●		068105		&MEA/7
TB20	0	068103	Terminal Block, 4Pos 1.5mm Com Clamp	●	068113		Jumper is Trimmed Down To 5 Position Between TB20-24	&MEA+.L3/3.16
TB21	0	068103	Terminal Block, 4Pos 1.5mm Com Clamp	●				&MEA/7.03
TB22	0	068103	Terminal Block, 4Pos 1.5mm Com Clamp	●				&MEA/21.02
TB23	0	068103	Terminal Block, 4Pos 1.5mm Com Clamp	●				&MEA+.L3/6.05
TB24	0	068103	Terminal Block, 4Pos 1.5mm Com Clamp	●		068105		&MEA/7
TB25	0	068103	Terminal Block, 4Pos 1.5mm Com Clamp	●	068113		Jumper is Trimmed Down To 2 Position Jumper Between TB25-26	&MEA/21
TB26	0	068103	Terminal Block, 4Pos 1.5mm Com Clamp	●		068105		&MEA+.L3/6.02

		Wood-Mizer®	
Project Description: WM4500 Standard			
Revision: A4.04		Pg Desc: Terminal line-up diagram	
Mounting Location: +Docs		Type: Terminal line-up diagram	
Prev. pg: D1	Page: D2	Next pg: D3	Total Pgs: 89

Terminal line-up diagram

Terminal strip +L5.L6-X5

Terminal				Jumper		End Plate	Remark	Terminal X-Ref
Ref. Des.	Level	P/N	Description	Diagram	P/N	P/N		
TB1	0	068104	Terminal Block, 4Pos 1.5mm GND Clamp	⋮		068105		&MEA+.L7/36.08
TB2	0	068103	Terminal Block, 4Pos 1.5mm Com Clamp	●	068113		Jumper is Trimmed Down To 2 Position Between TB2-3	&MEA+.L7/36.07
TB3	0	068103	Terminal Block, 4Pos 1.5mm Com Clamp	●		068105		&MEA+L1.L4/15.19
TB4	0	068103	Terminal Block, 4Pos 1.5mm Com Clamp	●	068113		Jumper is Trimmed Down To 2 Position Between TB4-5	&MEA+L1.L4/23.02
TB5	0	068103	Terminal Block, 4Pos 1.5mm Com Clamp	●		068105		&MEA+.L7/36.06
TB6	1	068119	Terminal Block, 2 Tier 2.5mm Clamp	⋮		068120		&MEA+L1.L4/17.05
TB6	2			⋮				&MEA+L1.L4/17.05
TB7	1	068119	Terminal Block, 2 Tier 2.5mm Clamp	⋮				&MEA+.L7/36.07
TB7	2			⋮				&MEA+.L7/36.08
TB8	1	068119	Terminal Block, 2 Tier 2.5mm Clamp	⋮				&MEA+L1.L4/17.07
TB8	2			⋮				&MEA+.L7/36.06
TB9	1	068119	Terminal Block, 2 Tier 2.5mm Clamp	⋮				&MEA+L1.L4/17.12
TB9	2			⋮				&MEA+L1.L4/17.12
TB10	1	068119	Terminal Block, 2 Tier 2.5mm Clamp	⋮				&MEA+L1.L4/22.06
TB10	2			⋮				&MEA+L1.L4/22.04
TB11	1	068119	Terminal Block, 2 Tier 2.5mm Clamp	⋮		068120		&MEA+L1.L4/18.02
TB11	2			⋮				
TB12	1	068119	Terminal Block, 2 Tier 2.5mm Clamp	⋮				&MEA+L1.L4/24.03
TB12	2			⋮				&MEA+L1.L4/24.03
TB13	1	068119	Terminal Block, 2 Tier 2.5mm Clamp	⋮				&MEA+L1.L4/24.04
TB13	2			⋮				&MEA+L1.L4/24.04
TB14	1	068119	Terminal Block, 2 Tier 2.5mm Clamp	⋮				&MEA+L1.L4/24.06
TB14	2			⋮				&MEA+L1.L4/24.05
TB15	1	068119	Terminal Block, 2 Tier 2.5mm Clamp	⋮				&MEA+L1.L4/24.08
TB15	2			⋮				&MEA+L1.L4/24.06
TB16	1	068119	Terminal Block, 2 Tier 2.5mm Clamp	⋮				&MEA+L1.L4/24.08
TB16	2			⋮				&MEA+L1.L4/24.09
TB17	1	068119	Terminal Block, 2 Tier 2.5mm Clamp	⋮		068120		&MEA+L1.L4/24.07
TB17	2			⋮				&MEA+L1.L4/24.09
TB18	1	068119	Terminal Block, 2 Tier 2.5mm Clamp	⋮				&MEA+L1.L4/25.03
TB18	2			⋮				&MEA+L1.L4/25.03
TB19	1	068119	Terminal Block, 2 Tier 2.5mm Clamp	⋮				&MEA+L1.L4/25.04
TB19	2			⋮				&MEA+L1.L4/25.04
TB20	1	068119	Terminal Block, 2 Tier 2.5mm Clamp	⋮				&MEA+L1.L4/25.06
TB20	2			⋮				&MEA+L1.L4/25.05

		Wood-Mizer®	
Project Description: WM4500 Standard			
Revision:	A4.04	Pg Desc: Terminal line-up diagram	
Mounting Location: +Docs		Type: Terminal line-up diagram	
Prev. pg:	D2	Page:	D3
Next pg:	D4	Total Pgs: 89	

Terminal line-up diagram

Terminal strip +L5.L6-X5

Terminal				Jumper		End Plate	Remark	Terminal X-Ref
Ref. Des.	Level	P/N	Description	Diagram	P/N	P/N		
TB21	1	068119	Terminal Block, 2 Tier 2.5mm Clamp	•				&MEA+L1.L4/25.08
TB21	2			•				&MEA+L1.L4/25.06
TB22	1	068119	Terminal Block, 2 Tier 2.5mm Clamp	•				&MEA+L1.L4/25.08
TB22	2			•				&MEA+L1.L4/25.09
TB23	1	068119	Terminal Block, 2 Tier 2.5mm Clamp	•		068120		&MEA+L1.L4/25.07
TB23	2			•				&MEA+L1.L4/25.09
TB24	1	068119	Terminal Block, 2 Tier 2.5mm Clamp	•				&MEA+L1.L4/23.02
TB24	2			•				&MEA+L1.L4/23.02
TB25	1	068119	Terminal Block, 2 Tier 2.5mm Clamp	•		068120		
TB25	2			•				&MEA+L1.L4/23.03
TB26	1	068119	Terminal Block, 2 Tier 2.5mm Clamp	•				&MEA+L1.L4/17.07
TB26	2			•				&MEA+L1.L4/17.07
TB27	1	068119	Terminal Block, 2 Tier 2.5mm Clamp	•				&MEA+L1.L4/17.07
TB27	2			•				&MEA+L1.L4/17.07
TB28	1	068119	Terminal Block, 2 Tier 2.5mm Clamp	•				&MEA+L1.L4/17.07
TB28	2			•				&MEA+L1.L4/17.07
TB29	1	068119	Terminal Block, 2 Tier 2.5mm Clamp	•		068120		&MEA+L1.L4/18.05
TB29	2			•				&MEA+L1.L4/18.03
TB30	1	068119	Terminal Block, 2 Tier 2.5mm Clamp	•		068120		&MEA+L1.L4/18
TB30	2			•				&MEA+L1.L4/18.05
TB31	1	068119	Terminal Block, 2 Tier 2.5mm Clamp	•				&MEA+L1.L4/15.19
TB31	2			•				&MEA+L1.L4/15.20
TB32	1	068119	Terminal Block, 2 Tier 2.5mm Clamp	•		068120		&MEA+L1.L4/15.18
TB32	2			•				

Terminal line-up diagram

Terminal strip +L11.L12-X6								
Terminal				Jumper		End Plate	Remark	Terminal X-Ref
Ref. Des.	Level	P/N	Description	Diagram	P/N	P/N		
TB1	0	068104	Terminal Block, 4Pos 1.5mm GND Clamp	⋮				&MEA+L1.L3/1.09
TB2	0	068104	Terminal Block, 4Pos 1.5mm GND Clamp	⋮		068105		&MEA+L1.L4/19.12
TB3	0	068103	Terminal Block, 4Pos 1.5mm Com Clamp	●	068113		Jumper is Trimmed Down To 2 Position Between TB3-4	&MEA+L1.L4/8.05
TB4	0	068103	Terminal Block, 4Pos 1.5mm Com Clamp	●		068105		&MEA+L1.L4/8.13
TB5	0	068103	Terminal Block, 4Pos 1.5mm Com Clamp	●	068113		Jumper is Trimmed Down To 3 Position Between TB5-7	&MEA+L1.L4/16.09
TB6	0	068103	Terminal Block, 4Pos 1.5mm Com Clamp	●				&MEA+L1.L4/26.02
TB7	0	068103	Terminal Block, 4Pos 1.5mm Com Clamp	●		068105		&MEA+L1.L4/19.12
TB8	0	068103	Terminal Block, 4Pos 1.5mm Com Clamp	●	068113		Jumper is Trimmed Down To 2 Position Between TB8-9	&MEA+L1.L4/23.07
TB9	0	068103	Terminal Block, 4Pos 1.5mm Com Clamp	●		068105		&MEA+L1.L4/23.06
TB10	1	068119	Terminal Block, 2 Tier 2.5mm Clamp	⋮				&MEA+L1.L4/17.02
TB10	2			⋮				&MEA+L1.L4/17.02
TB11	1	068119	Terminal Block, 2 Tier 2.5mm Clamp	⋮				&MEA+L1.L4/17.02
TB11	2			⋮				&MEA+L1.L4/17.02
TB12	1	068119	Terminal Block, 2 Tier 2.5mm Clamp	⋮				&MEA+L1.L4/7.15
TB12	2			⋮				&MEA+L1.L4/7.17
TB13	1	068119	Terminal Block, 2 Tier 2.5mm Clamp	⋮				&MEA+L1.L4/8.09
TB13	2			⋮				&MEA+L1.L4/8.07
TB14	1	068119	Terminal Block, 2 Tier 2.5mm Clamp	⋮				
TB14	2			⋮				&MEA+L1.L4/8.11
TB15	1	068119	Terminal Block, 2 Tier 2.5mm Clamp	⋮				
TB15	2			⋮				&MEA+L1.L4/8.13
TB16	1	068119	Terminal Block, 2 Tier 2.5mm Clamp	⋮		068120		&MEA+L1.L4/23.13
TB16	2			⋮				&MEA+L1.L4/23.10
TB17	1	068119	Terminal Block, 2 Tier 2.5mm Clamp	⋮				&MEA+L1.L4/8
TB17	2			⋮				&MEA+L1.L4/8.16

		Wood-Mizer®	
Project Description: WM4500 Standard			
Revision:	A4.04	Pg Desc: Terminal line-up diagram	
Mounting Location: +Docs		Type: Terminal line-up diagram	
Prev. pg:	D4	Page:	D5
Next pg:		D6	Total Pgs: 89

Terminal line-up diagram

Terminal strip +L9.L10-X7

Terminal				Jumper		End Plate	Remark	Terminal X-Ref
Ref. Des.	Level	P/N	Description	Diagram	P/N	P/N		
TB1	0	068104	Terminal Block, 4Pos 1.5mm GND Clamp	⋮				&MEA+L1.L3/1.08
TB2	0	068104	Terminal Block, 4Pos 1.5mm GND Clamp	⋮				&MEA+L1.L4/9.04
TB3	0	068104	Terminal Block, 4Pos 1.5mm GND Clamp	⋮				&MEA+L1.L4/9.07
TB4	0	068104	Terminal Block, 4Pos 1.5mm GND Clamp	⋮				&MEA+L1.L4/9.11
TB6	0	068103	Terminal Block, 4Pos 1.5mm Com Clamp	●	068113		Jumper is Trimmed Down To 5 Position Between TB6-10	&MEA+L1.L4/9.02
TB7	0	068103	Terminal Block, 4Pos 1.5mm Com Clamp	●				&MEA+L1.L4/9.02
TB8	0	068103	Terminal Block, 4Pos 1.5mm Com Clamp	●				&MEA+L1.L4/9.06
TB9	0	068103	Terminal Block, 4Pos 1.5mm Com Clamp	●				&MEA+L1.L4/9.09
TB11	0	068103	Terminal Block, 4Pos 1.5mm Com Clamp	⋮		068105		&MEA+L1.L4/16.12
TB12	0	068103	Terminal Block, 4Pos 1.5mm Com Clamp	⋮		068105		&MEA+L1.L4/16.12
TB13	1	068119	Terminal Block, 2 Tier 2.5mm Clamp	⋮				&MEA+L1.L4/9.02
TB13	2			⋮				&MEA+L1.L4/9.05
TB14	1	068119	Terminal Block, 2 Tier 2.5mm Clamp	⋮				&MEA+L1.L4/9.06
TB14	2			⋮				&MEA+L1.L4/9.08
TB15	1	068119	Terminal Block, 2 Tier 2.5mm Clamp	⋮				&MEA+L1.L4/9.09
TB15	2			⋮				&MEA+L1.L4/9.12
TB16	1	068119	Terminal Block, 2 Tier 2.5mm Clamp	⋮				&MEA+L1.L4/9.13
TB16	2			⋮				&MEA+L1.L4/9.15
TB17	1	068119	Terminal Block, 2 Tier 2.5mm Clamp	⋮				&MEA+L1.L4/9.16
TB17	2			⋮				&MEA+L1.L4/9.19
TB18	1	068119	Terminal Block, 2 Tier 2.5mm Clamp	⋮				&MEA+L1.L4/10.02
TB18	2			⋮				&MEA+L1.L4/10.04
TB19	1	068119	Terminal Block, 2 Tier 2.5mm Clamp	⋮				&MEA+L1.L4/10.05
TB19	2			⋮				&MEA+L1.L4/10.08
TB20	1	068119	Terminal Block, 2 Tier 2.5mm Clamp	⋮				&MEA+L1.L4/10.09
TB20	2			⋮				&MEA+L1.L4/10.11
TB21	1	068119	Terminal Block, 2 Tier 2.5mm Clamp	⋮				&MEA+L1.L4/10.12
TB21	2			⋮				
TB22	1	068119	Terminal Block, 2 Tier 2.5mm Clamp	⋮				&MEA+L1.L4/10.15
TB22	2			⋮				&MEA+L1.L4/10.17
TB23	1	068119	Terminal Block, 2 Tier 2.5mm Clamp	⋮				&MEA+L1.L4/11.02
TB23	2			⋮				&MEA+L1.L4/11.04
TB24	1	068119	Terminal Block, 2 Tier 2.5mm Clamp	⋮				&MEA+L1.L4/11.05
TB24	2			⋮				&MEA+L1.L4/11.07
TB25	1	068119	Terminal Block, 2 Tier 2.5mm Clamp	⋮				&MEA+L1.L4/34.07

		Wood-Mizer®	
Project Description: WM4500 Standard			
Revision:	A4.04	Pg Desc: Terminal line-up diagram	
Mounting Location:	+Docs	Type: Terminal line-up diagram	
Prev. pg:	D5	Page:	D6
		Next pg:	D7
		Total Pgs:	89

Terminal line-up diagram

Terminal strip +L9.L10-X7

Terminal				Jumper		End Plate	Remark	Terminal X-Ref
Ref. Des.	Level	P/N	Description	Diagram	P/N	P/N		
TB25	2			'				&MEA+L1.L4/34.08
TB26	1	068119	Terminal Block, 2 Tier 2.5mm Clamp	'				&MEA+L1.L4/11.09
TB26	2			'				

Terminal line-up diagram

Terminal strip +L5.L15-X9

Terminal				Jumper		End Plate	Remark	Terminal X-Ref
Ref. Des.	Level	P/N	Description	Diagram	P/N	P/N		
TB1	0	052293	Junction Block, 3-Position Wire Clamp	I				&MEA+L1.L4/15.15
TB2	0	052293-2	Junction Block, 2-Position Wire Clamp	I				&MEA+L1.L4/15.14
TB3	0	052293-2	Junction Block, 2-Position Wire Clamp	I				&MEA+L1.L4/15.13
TB4	0	052293	Junction Block, 3-Position Wire Clamp	I				&MEA+L1.L4/15.14

		Wood-Mizer®	
Project Description: WM4500 Standard			
Revision: A4.04		Pg Desc: Terminal line-up diagram	
Mounting Location: +Docs		Type: Terminal line-up diagram	
Prev. pg: D7	Page: D8	Next pg: E1	Total Pgs: 89

Cable Overview

Wood-Mizer_Cable_Overview

Cable Designation	Cable Part Number	Cable Description	Cable X-Ref
W1	069958 069958	Cable Assy, Ind. Mill Blade Motor Cable Assy, Ind. Mill Blade Mtr Full Ex	+L1.L3/1.118
W2	069993	Cable Assy, Ind. Mill Hydraulic Mtr	+L1.L3/2.202
W3	078442 078442	Cable Assy, Ind. Mill Feed Motor Cable Assy, Ind. Mill Feed Mtr Full Ex	+L1.L3/2.208
W4	068179	Cable Assy, Ind. Mill Up/Dn Servo Mtr	+L1.L3/2.214
W5	068180	Cable Assy, Ind. Mill Up/Dn Servo Enc	+L1.L3/2.213
W6	069959	Cable Assy, Ind. Mill Debarker Motor	+L1.L3/3.302
W20	069962	Cable Assy, Ind. Mill Head Box	+L1.L4/7.708
W21	078656	Cable Assy, Ind. Mill Hydraulic Control	+L1.L4/10.1002
W22	078657	Cable Assy, Ind. Mill Operator Junction	+L1.L4/16.1616
W23	078658	Cable Assy, Ind. Mill HMI Control	+L1.L4/17.1710
W30	078659	Cable Assy, Ind. Mill Left Joystick	+L1.L4/24.2403
W31	078660	Cable Assy, Ind. Mill Right Joystick	+L1.L4/25.2503
W32	078054	Cable Assy, Ind. Mill Sec. Side Supports	+L1.L4/15.1518
W33	078053	Cable Assy, Ind. Mill Sd Spt Ft Pdl	+L1.L4/15.1513
W34	069963	Cable Assy, Ind. Mill Seat Switch	+L1.L4/17.1705
W35	078661	Cable Assy, Ind. Mill Foot Pedal	+L1.L4/23.2302
W36	078662	Cable Assy, Ind. Mill Blade Break Prox	+L1.L4/23.2310
W37	078663	Cable Assy, Ind. Mill Ball Nut Prox	+L1.L4/23.2312
W38	069988	Cable Assy, Ind. Mill Blade Guide Motor	+L1.L4/7.715
W39	068074	Cable Assy, Ind. Mill Laser	+L1.L4/8.813
W40	068048	Cable Assy, Ind. Mill Feed Encoder Pwr	+L1.L4/19.1911
W40A	068206	Connector Assy, Ind. Mill Feed Encoder	+L1.L4/19.1911
W41	078791	Cable Assy, Drag Back Solenoid	+L1.L4/8.802
W42	078665	Cable Assy, Ind. Mill Prop Valve	+L1.L4/34.3407
W61	069977	Cable Assy, Ind. Mill Bld Brk Sol.	+L1.L4/8.807
W62	069978	Cable Assy, Ind. Mill Blw Off Sol.	+L1.L4/8.809
W63	069979	Cable Assy, Ind. Mill Debarker Sol.	+L1.L4/8.811
W64	069966	Cable Assy, Ind. Mill Clamp In/Out Sol	+L1.L4/9.902
W65	069967	Cable Assy, Ind. Mill Turner Up/Dn Sol.	+L1.L4/9.906
W66	069968	Cable Assy, Ind. Mill Clamp Up/Dn Sol.	+L1.L4/9.909
W67	069969	Cable Assy, Ind. Mill Toe #1 Up/Dn Sol.	+L1.L4/9.913
W68	069970	Cable Assy, Ind. Mill Pwr Tpr Fwd/Rv Sol.	+L1.L4/9.916
W69	069971	Cable Assy, Ind. Mill Toe #2 Up/Dn Sol.	+L1.L4/10.1002
W70	069972	Cable Assy, Ind. Mill Toe #3 Up/Dn Sol.	+L1.L4/10.1005
W71	069973	Cable Assy, Ind. Mill Sd Sup Up/Dn Sol.	+L1.L4/10.1009

		Wood-Mizer®	
Project Description: WM4500 Standard			
Revision:	A4.04	Pg Desc: Cable overview	
Mounting Location: +Docs		Type: Cable overview	
Prev. pg:	D8	Page:	E1
Next pg:		E2	Total Pgs: 89

Cable Overview

Cable Designation	Cable Part Number	Cable Description	Cable X-Ref
W72	068189	Cable Assy, Ind. Mill Conveyor Sol.	+L1.L4/10.1012
W73	069974	Cable Assy, Ind. Mill Pwr Tpr Fwd/Rv Sol.	+L1.L4/10.1014
W74	069975	Cable Assy, Ind. Mill Loader Up/Dn Sol.	+L1.L4/11.1102
W75	069976	Cable Assy, Ind. Mill Log Deck Fwd/Rev S	+L1.L4/11.1105
W77	069978	Cable Assy, Ind. Mill Blw Off Sol.	+L1.L4/8.816
W80	078905	Cable Assy, Pull Down Clamp 1 Up/Down	+L9/38.3802
W81	078906	Cable Assy, Pull Down Clamp 1 In/Out	+L9/38.3811
W82	078907	Cable Assy, Pull Down Clamp 2 Up/Down	+L9/39.3902
W83	078908	Cable Assy, Pull Down Clamp 2 In/Out	+L9/39.3911
W90	078055	Cable Assy, Ind. Mill Sec Sd Spt Sol	+L1.L4/15.1513
W100	069937	Cable Assy, Ind. Mill CANopen PLC	+L1.L4/21.2111
W101	069873	Cable Assy, Ind. Mill CANopen Feed Drive	+L1.L4/19.1902
W102	069874	Cable Assy, Ind. Mill CANopen Up/Dn Driv	+L1.L4/19.1902
W103.A	068029	Connector Assy, Ind. Mill CANopen Main	+L1.L4/19.1908
W103.B	068283	Cable Assy, Ind. Mill Encoder CAN	+L1.L4/19.1908
W104	078897	Cable Assy, Pull Down Clamps Mdl CAN	+L9/37.3711
W120	069923	Cable Assy, Ind. Mill Modbus Soft Start	+L1.L4/21.2106
W121	069923-1	Cable Assy, Ind. Mill Modbus Soft Start Jnct	+L1.L3/4.415
W130	068162	Cable Assy, Ind. Mill Ethernet PLC	+L1.L4/21.2108
W131.A	069888	Cable Assy, Ind. Mill Ethernet Main Inte	+L1.L4/19.1918
W131.B	069997	Cable Assy, Ind. Mill HMI Ethernet	+L5.L7/36.3610
W131.C	069986	Cable Assy, Ind. Mill Ethernet HMI Int	+L5.L7/36.3610
W140	068178	Receptacle, Panel Mount USB	+L5.L7/36.3608
W200	078895	Connector Assy, Ind. Mill Remote Pwr	+L9/37.3706
W201	078898	Cable Assy, Pull Down Clamps Mdl Pwr	+L9/37.3706
Z1	078785	Harness Assy, Ind. Mill Disconnect	+L1.L3/1.101
Z3	069935	Harness Assy, Ind. Mill Transformer	+L1.L3/3.306



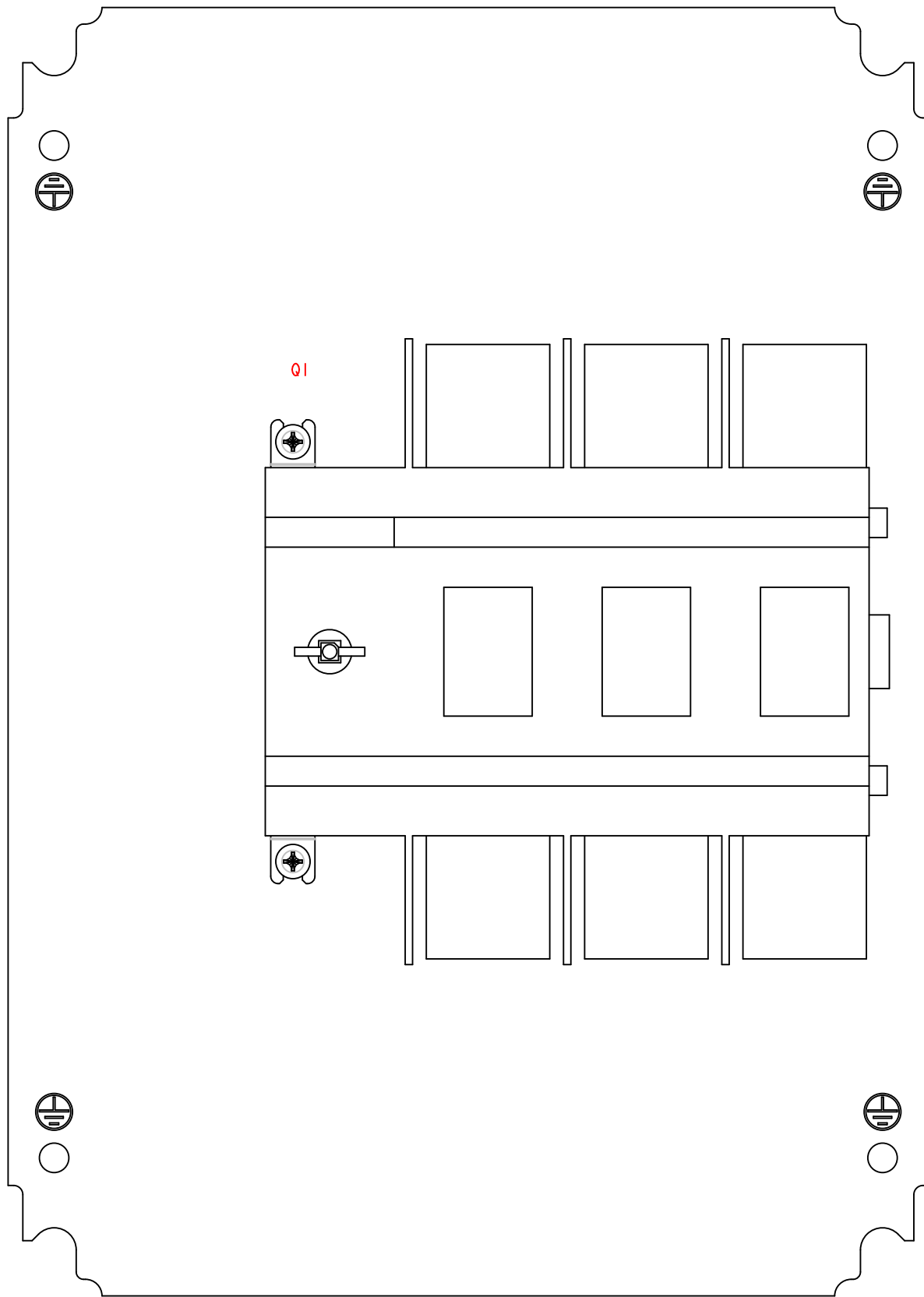

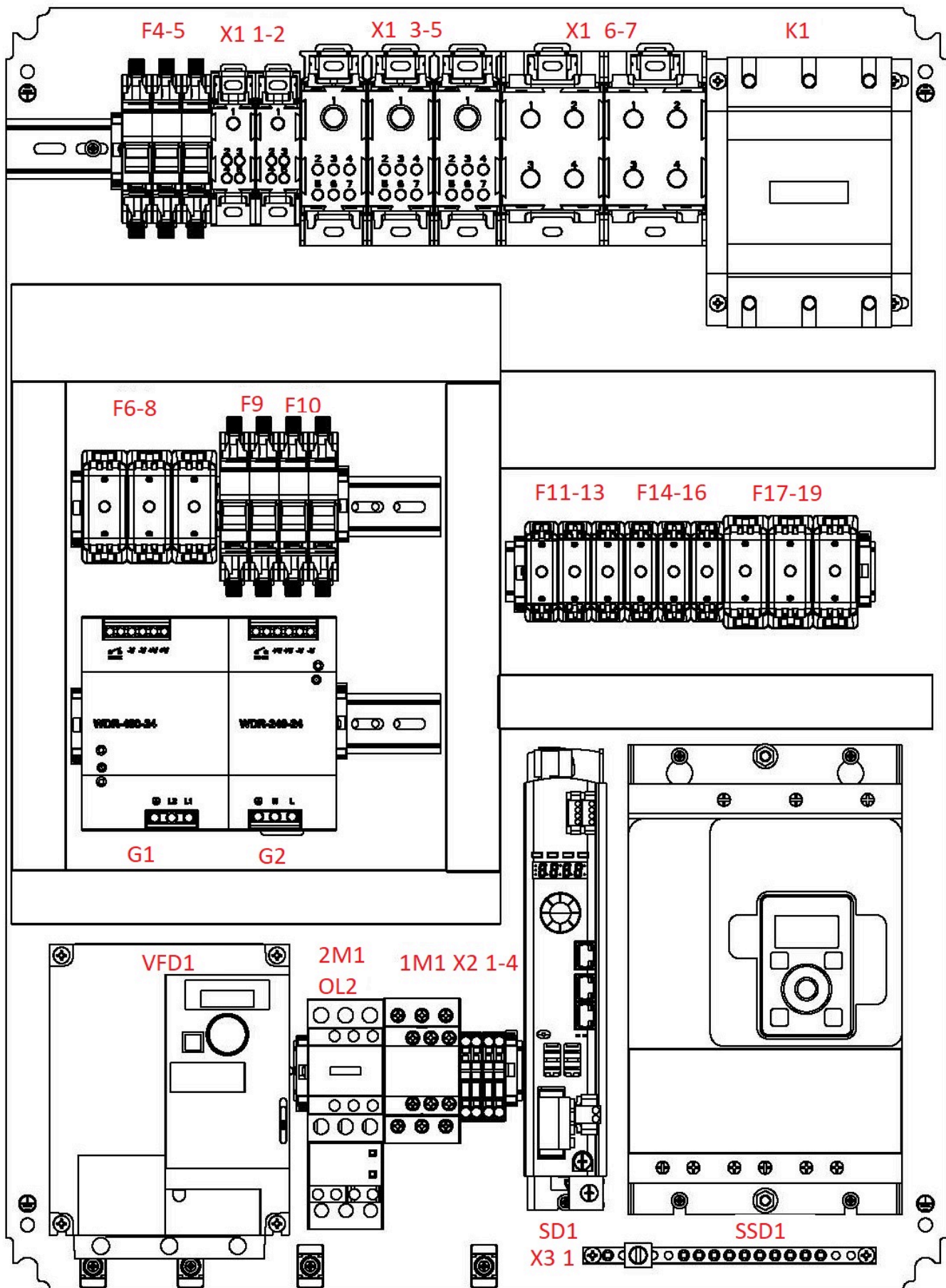

 Wood-Mizer®	
Project Description: WM4500 Standard	
Revision: A4.04	Pg Desc: Main Control Disconnect Layout
Mounting Location: +Docs	Type: Panel layout
Prev. pg: F1	Page: F2
Next pg: F3	Total Pgs: 89

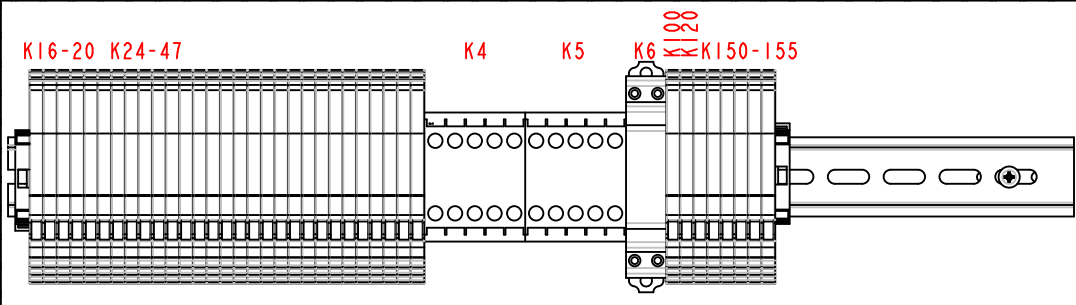
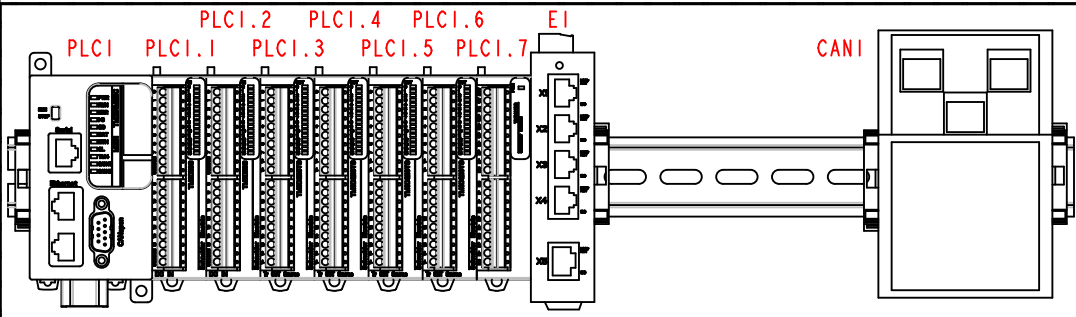
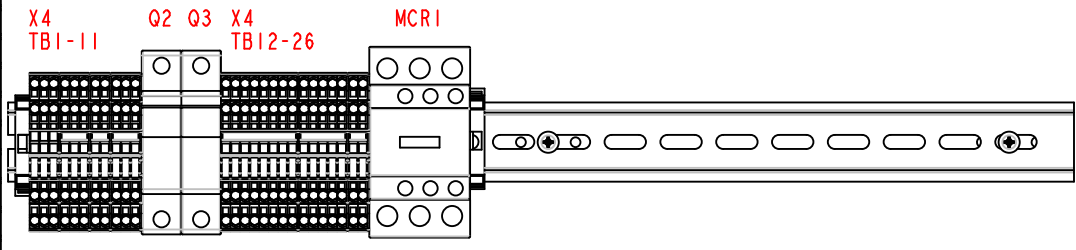

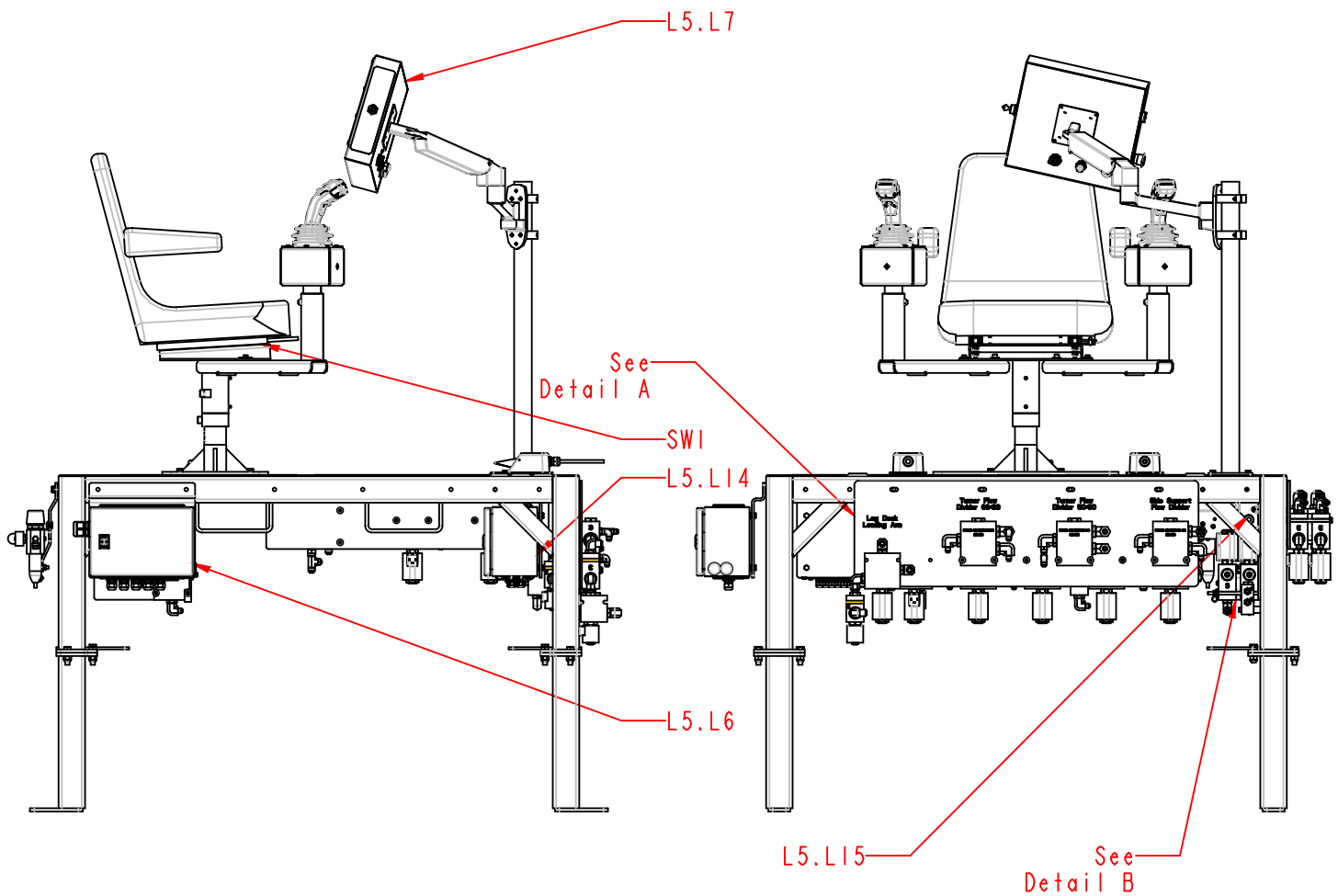
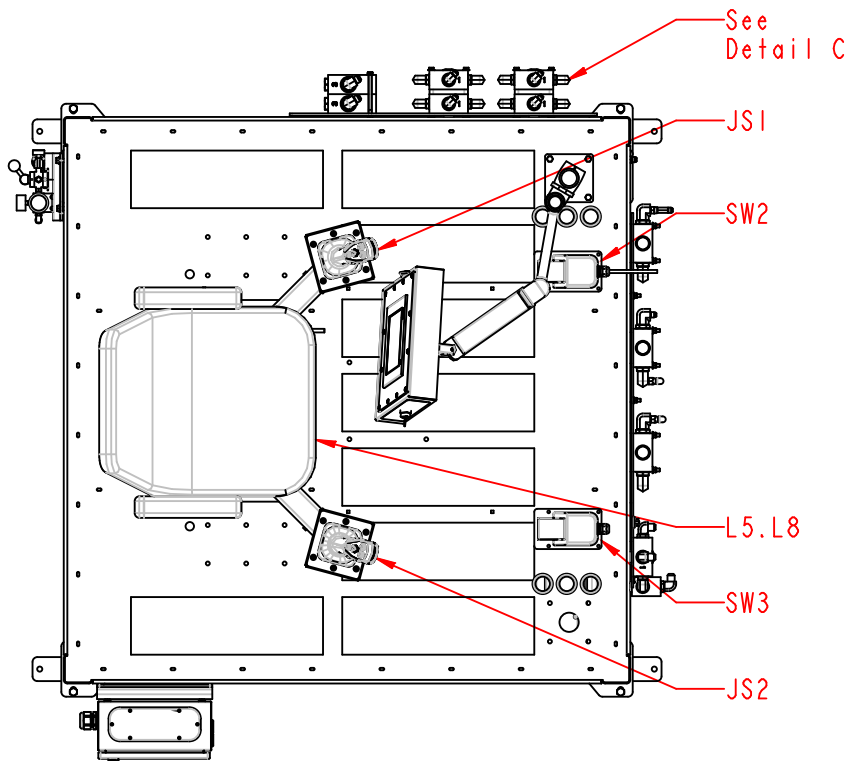

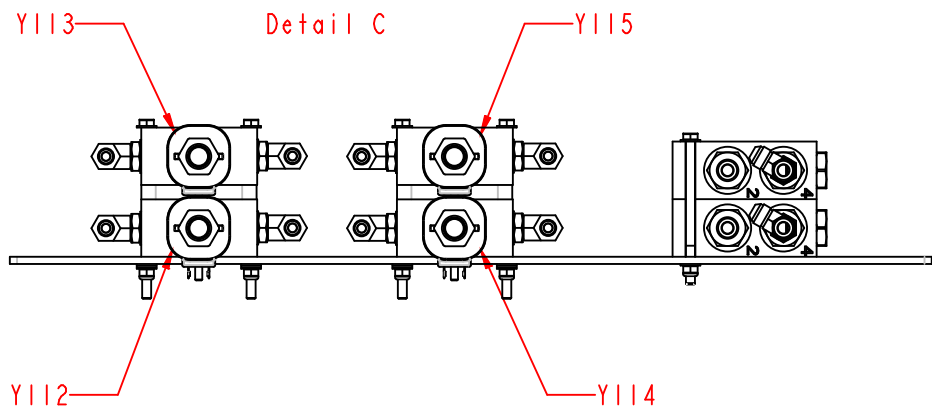
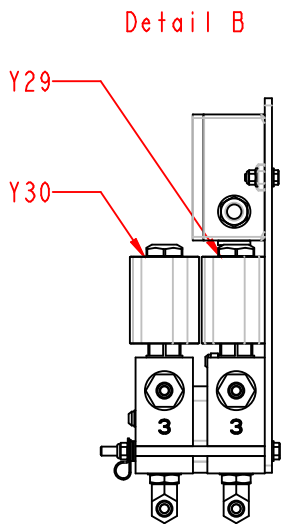
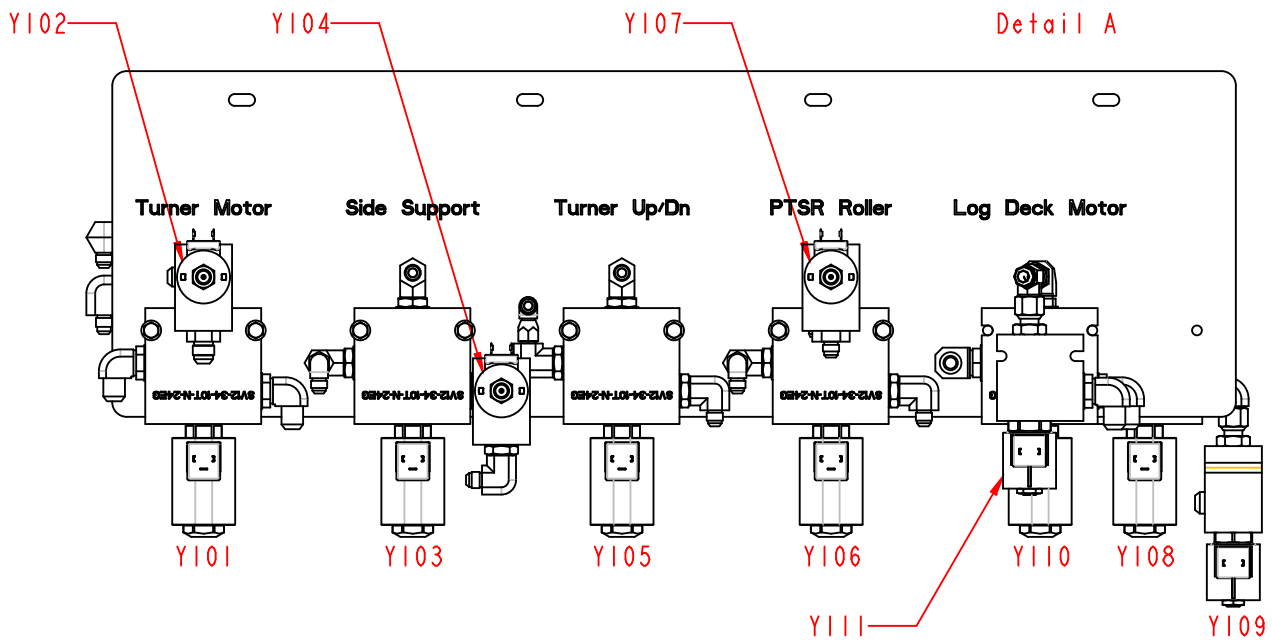





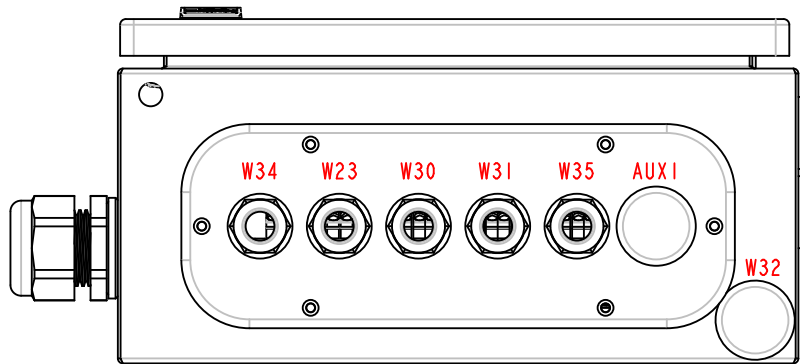
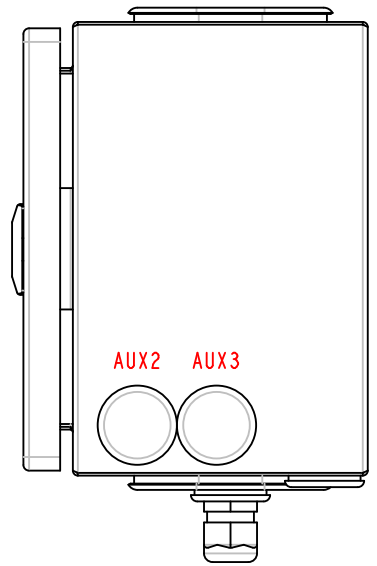
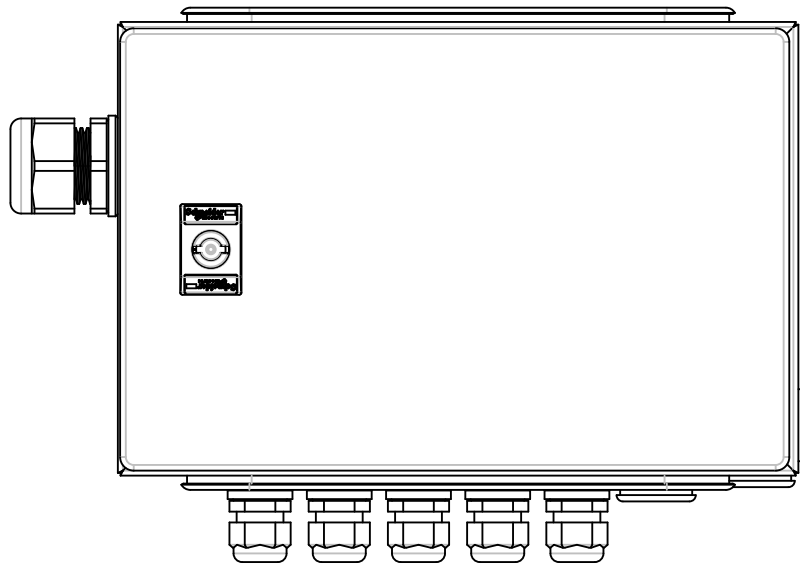
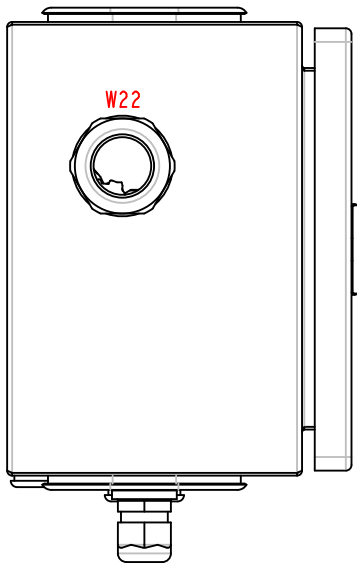
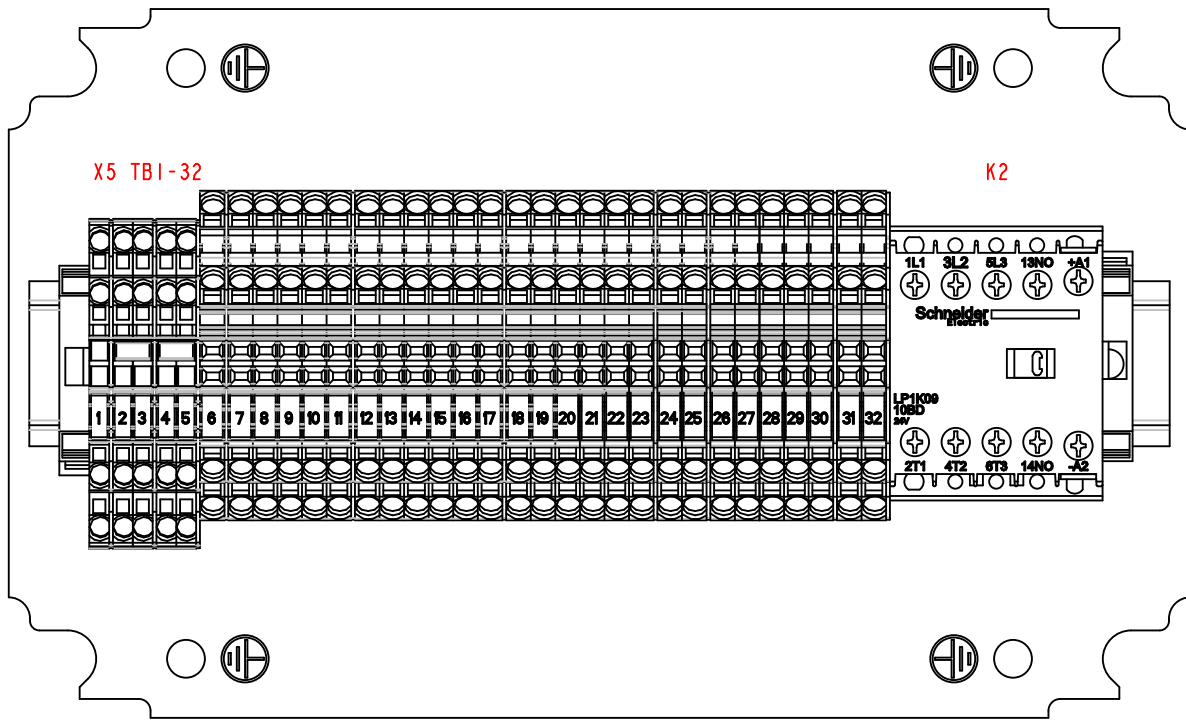

		Wood-Mizer®	
Project Description: WM4500 Standard			
Revision:	A4.04	Pg Desc: Operator Ctl Solenoid Layout	
Mounting Location:	+Docs	Type: Panel layout	
Prev. pg:	F5	Page:	F6
		Next pg:	F7
			Total Pgs: 89

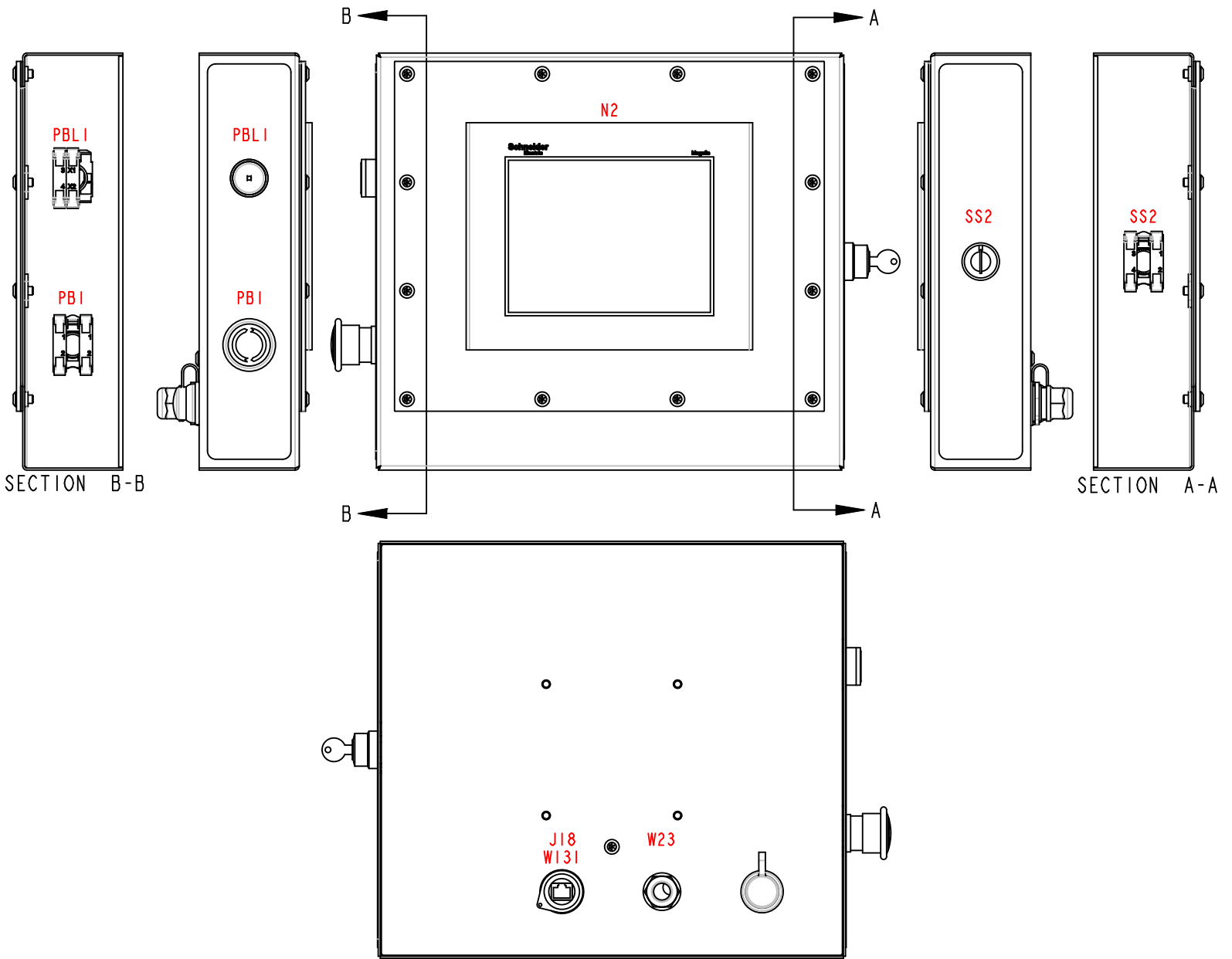

 Wood-Mizer®	
Project Description: WM4500 Standard	
Revision: A4.04	Pg Desc: Operator Ctl Junction Layout
Mounting Location: +Docs	Type: Panel layout
Prev. pg: F6	Page: F7
Next pg: F8	Total Pgs: 89



 Wood-Mizer®			
Project Description: WM4500 Standard			
Revision: A4.04	Pg Desc: Operator Ctl HMI Layout		
Mounting Location: +Docs			
Type: Panel layout			
Prev. pg: F7	Page: F8	Next pg: F9	Total Pgs: 89

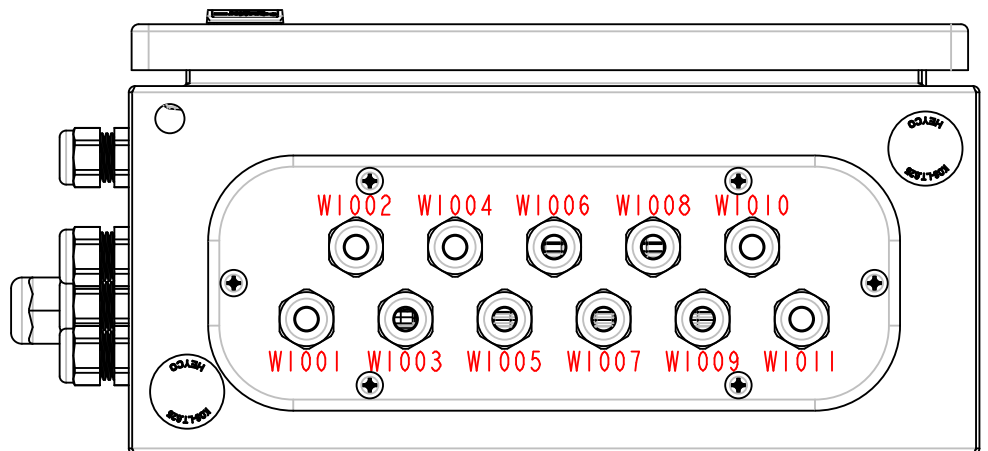
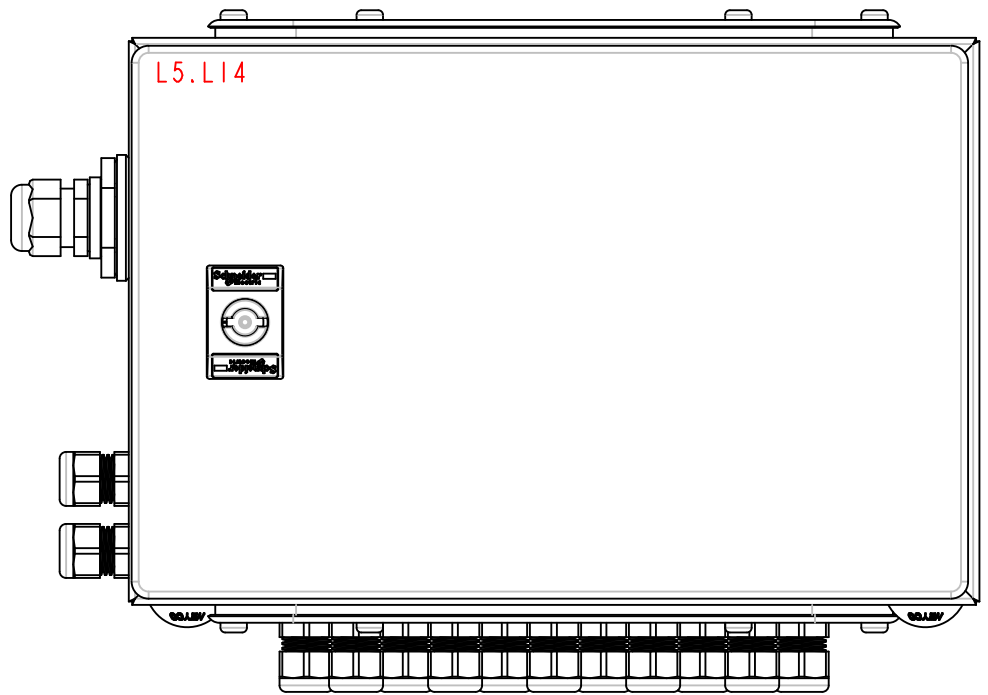
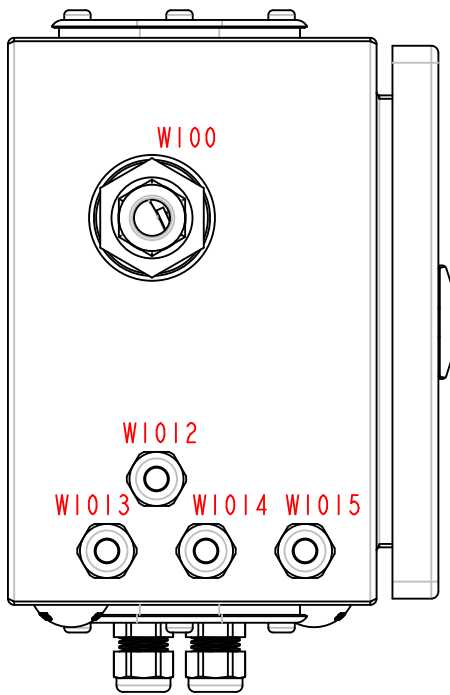
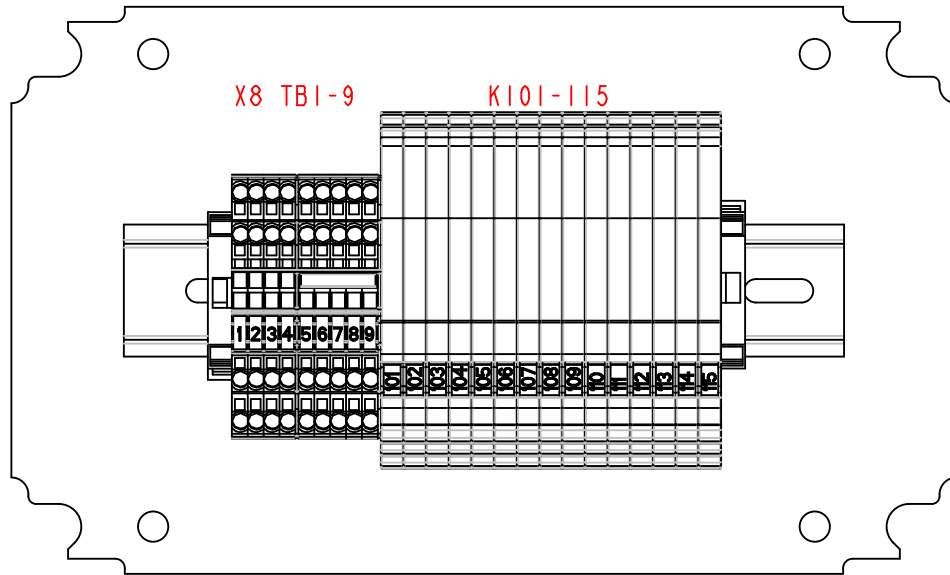

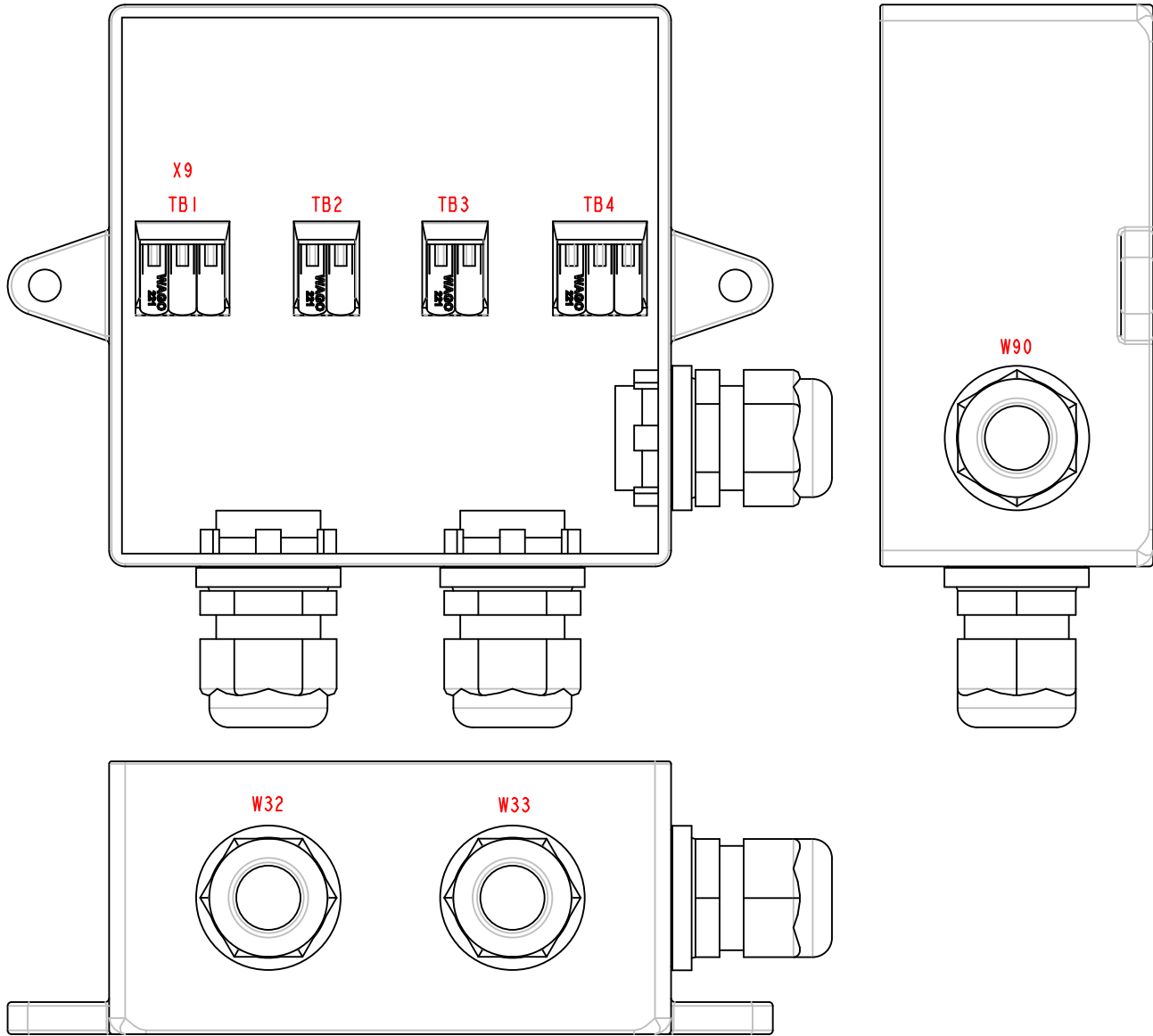

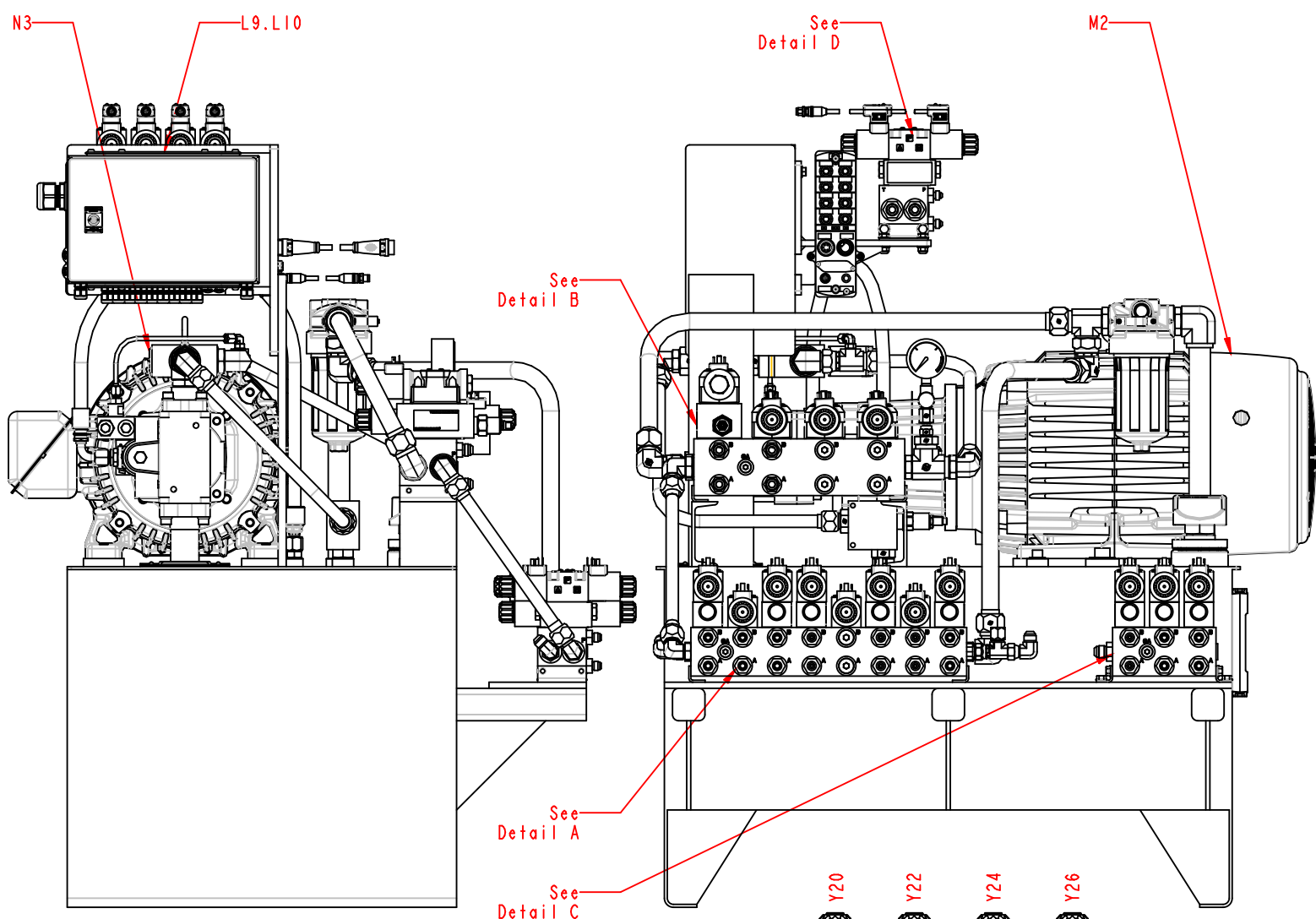

Detail A

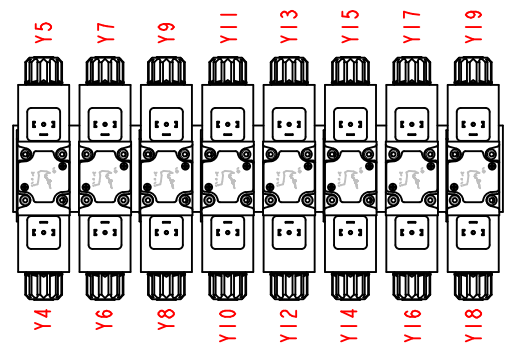

Detail B

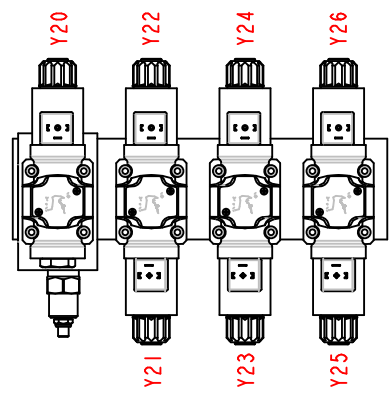

Detail C

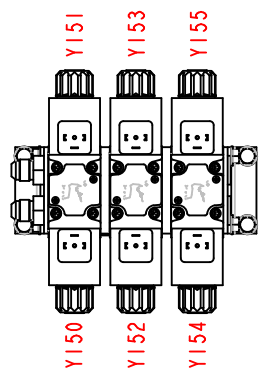

Detail D

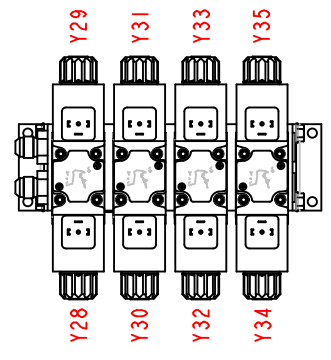

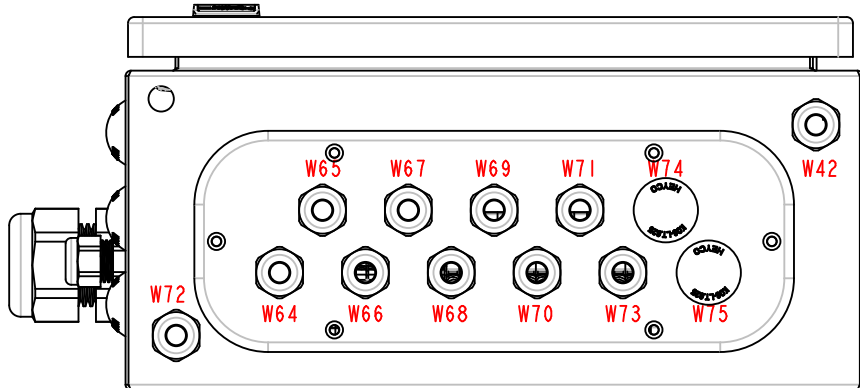
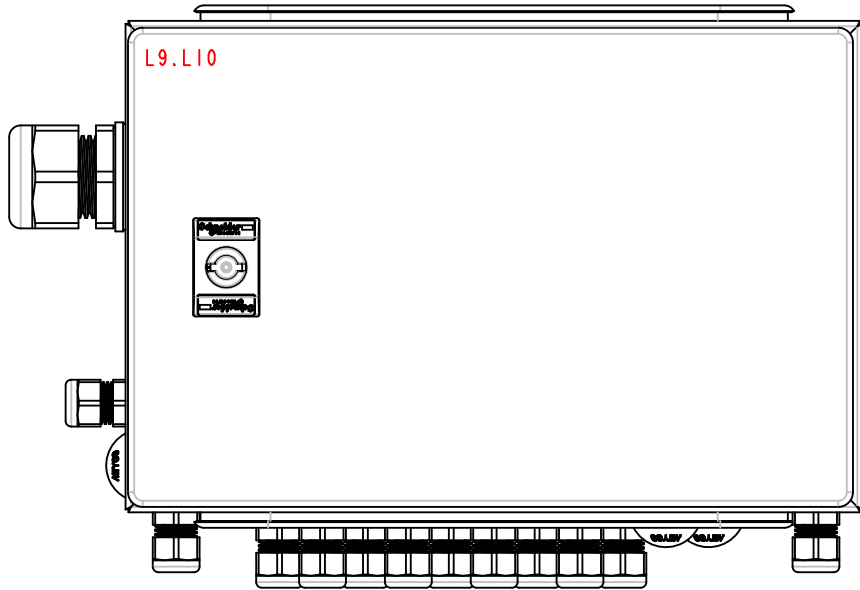
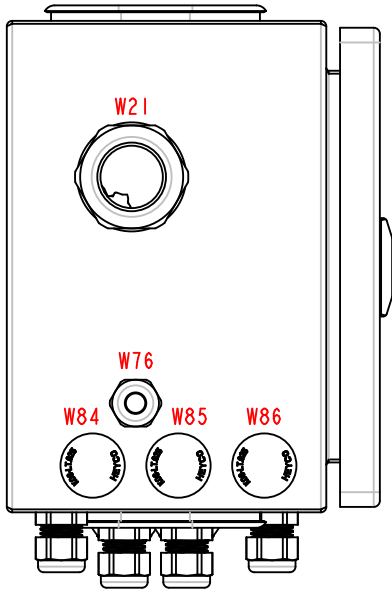
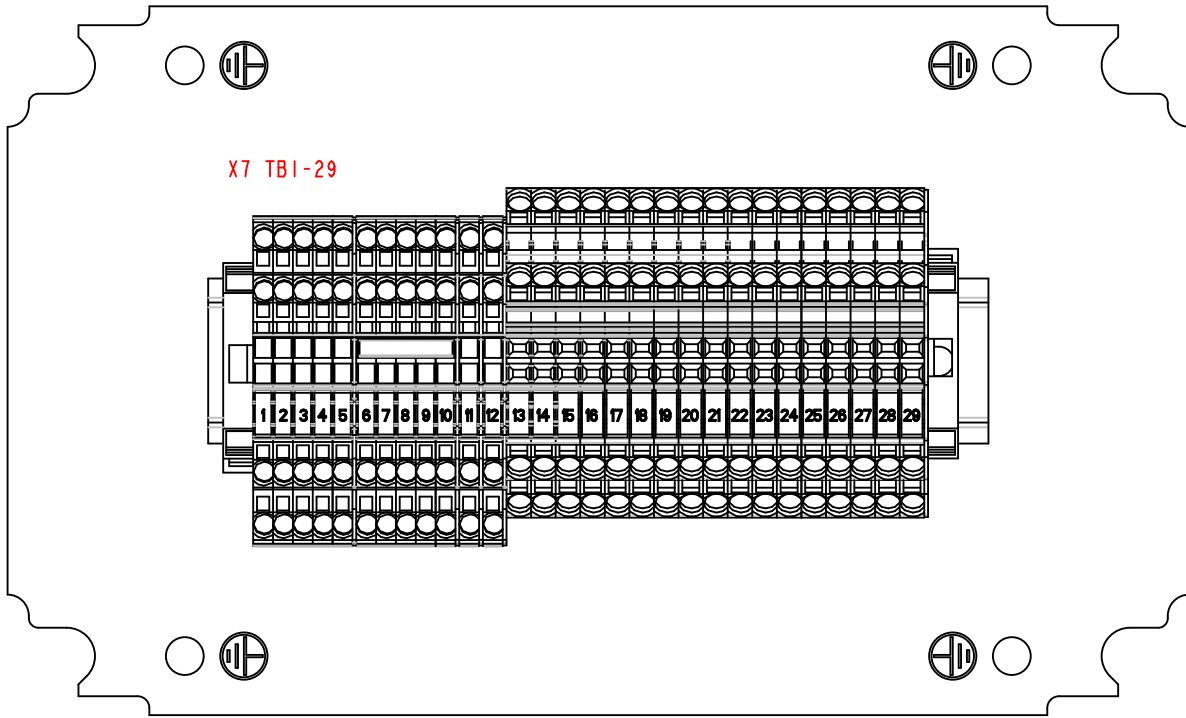

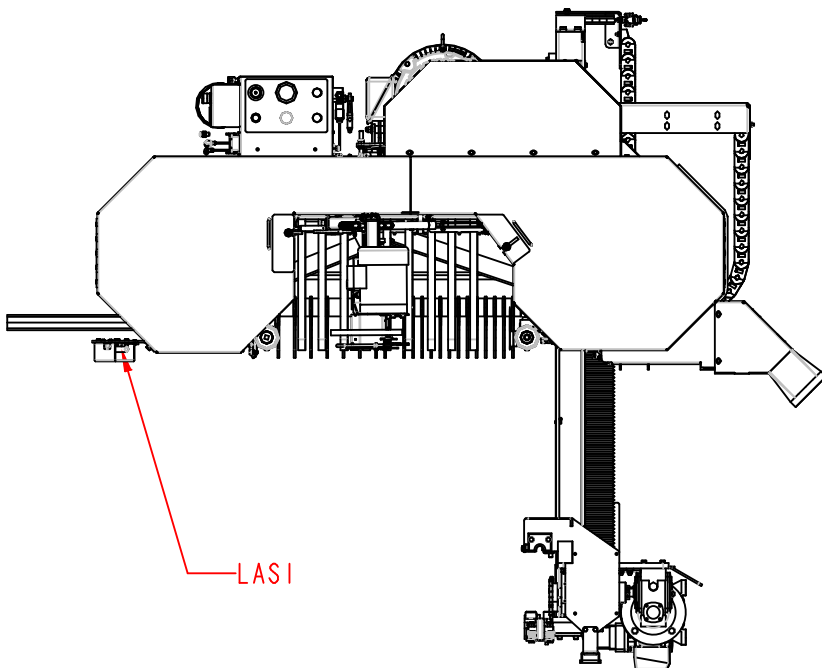

LAS I

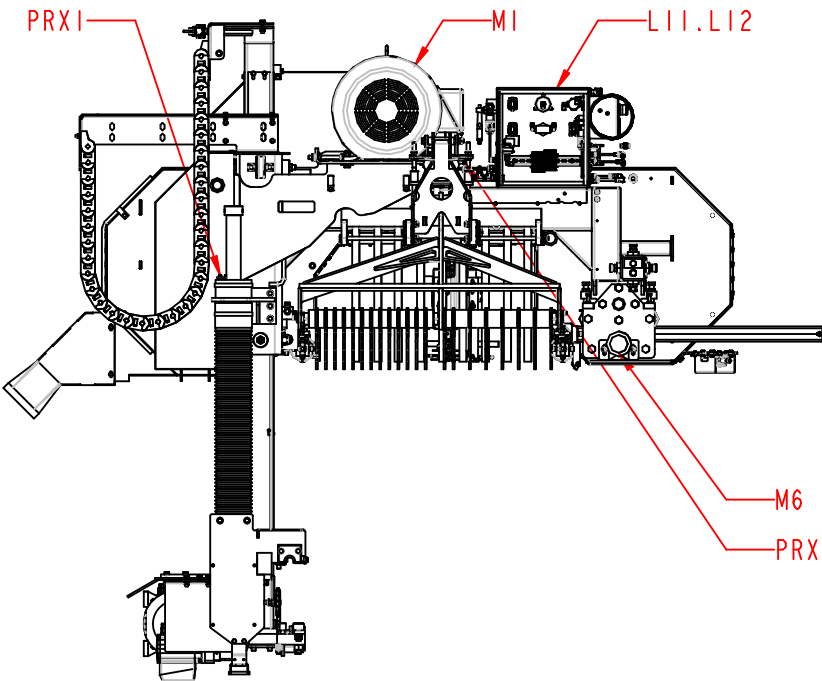

PRX I

MI

L11.L12

M6

PRX I

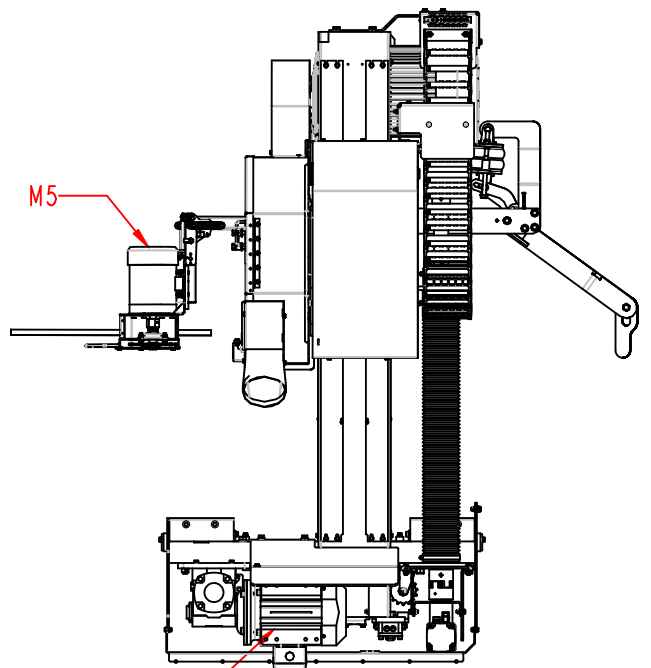



M5

ENCI

M3

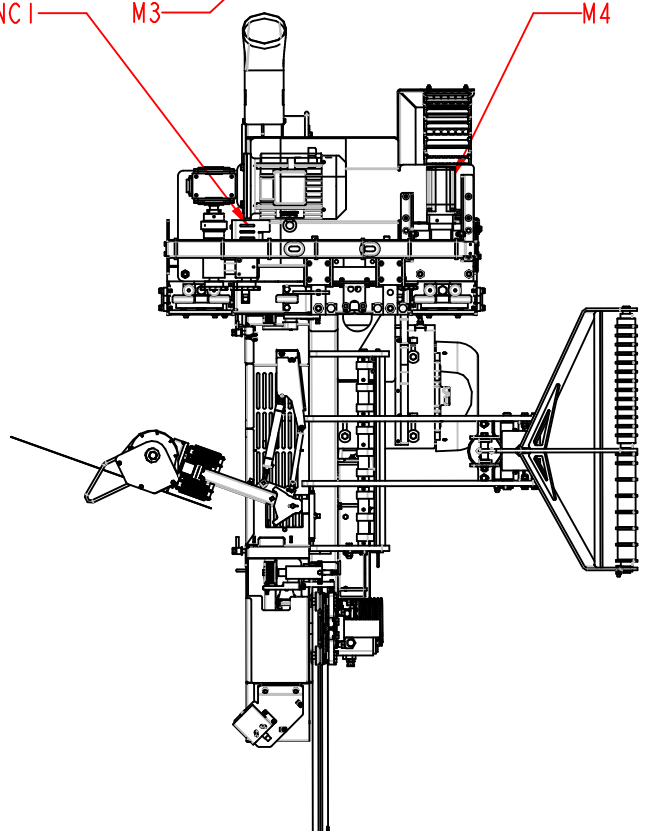
M4



		Wood-Mizer®	
Project Description: WM4500 Standard			
Revision: A4.04		Pg Desc: Head Control Layout	
Mounting Location: +Docs		Type: Panel layout	
Prev. pg: F12	Page: F13	Next pg: F14	Total Pgs: 89

Y3 (Inside Cover)
Debarker In Solenoid

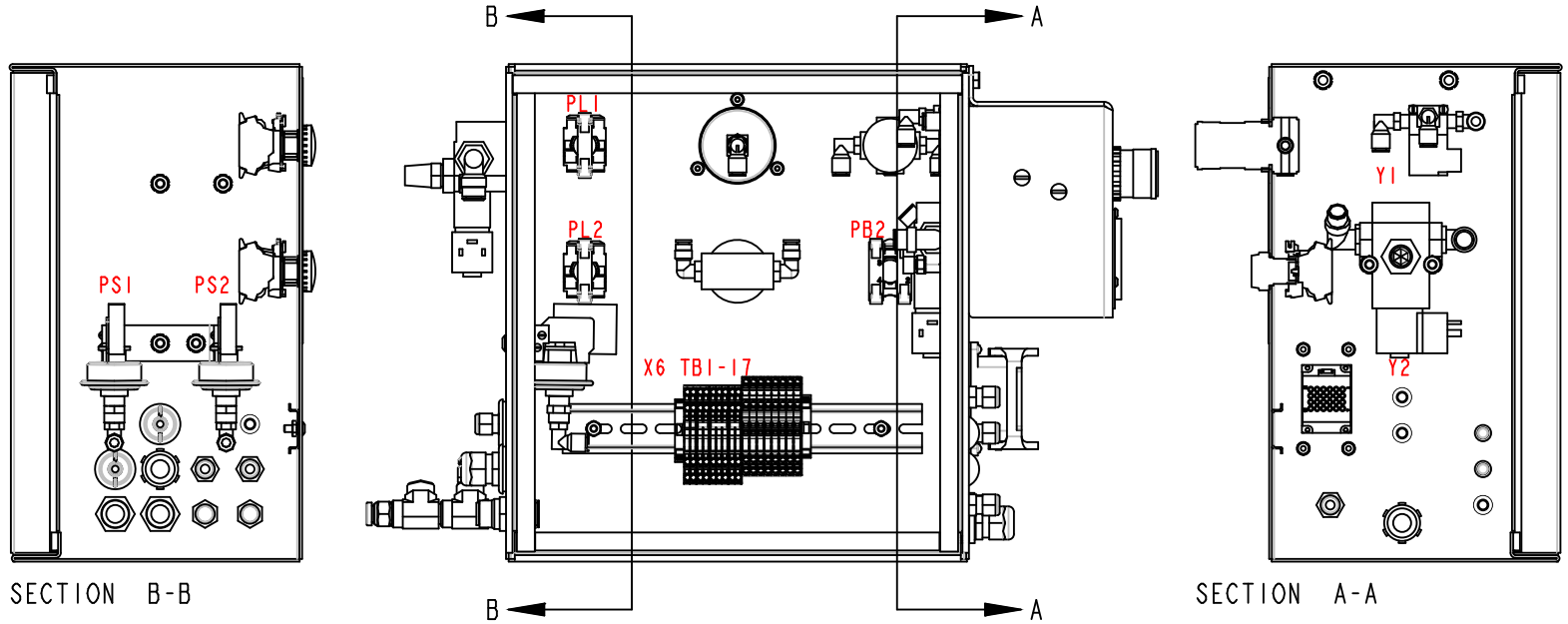
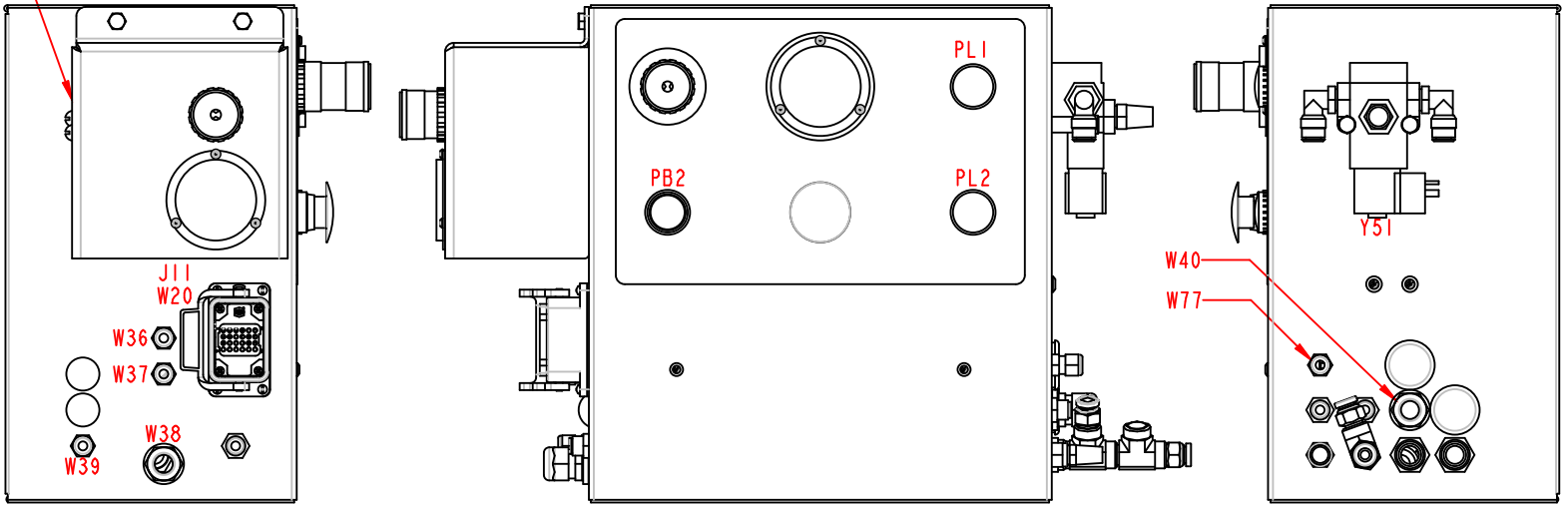

Revision History

Date	Revision	Revision Record	Drawn By	Checked By
8/6/18	A1.00	Release to production	JRF	SDC
4/26/19	A2.00	Added Pull Down Clamp Functions	JRF	SDC
12/6/19	A3.00	Full Bed Extension	JRF	SDC

		Wood-Mizer®	
Project Description: WM4500 Standard			
Revision: A4.04		Pg Desc: Revision History	
Mounting Location: +		Type: Overview	
Prev. pg: A1	Page: B1	Next pg: +L9/1	Total Pgs: 89

A

B

C

D

E

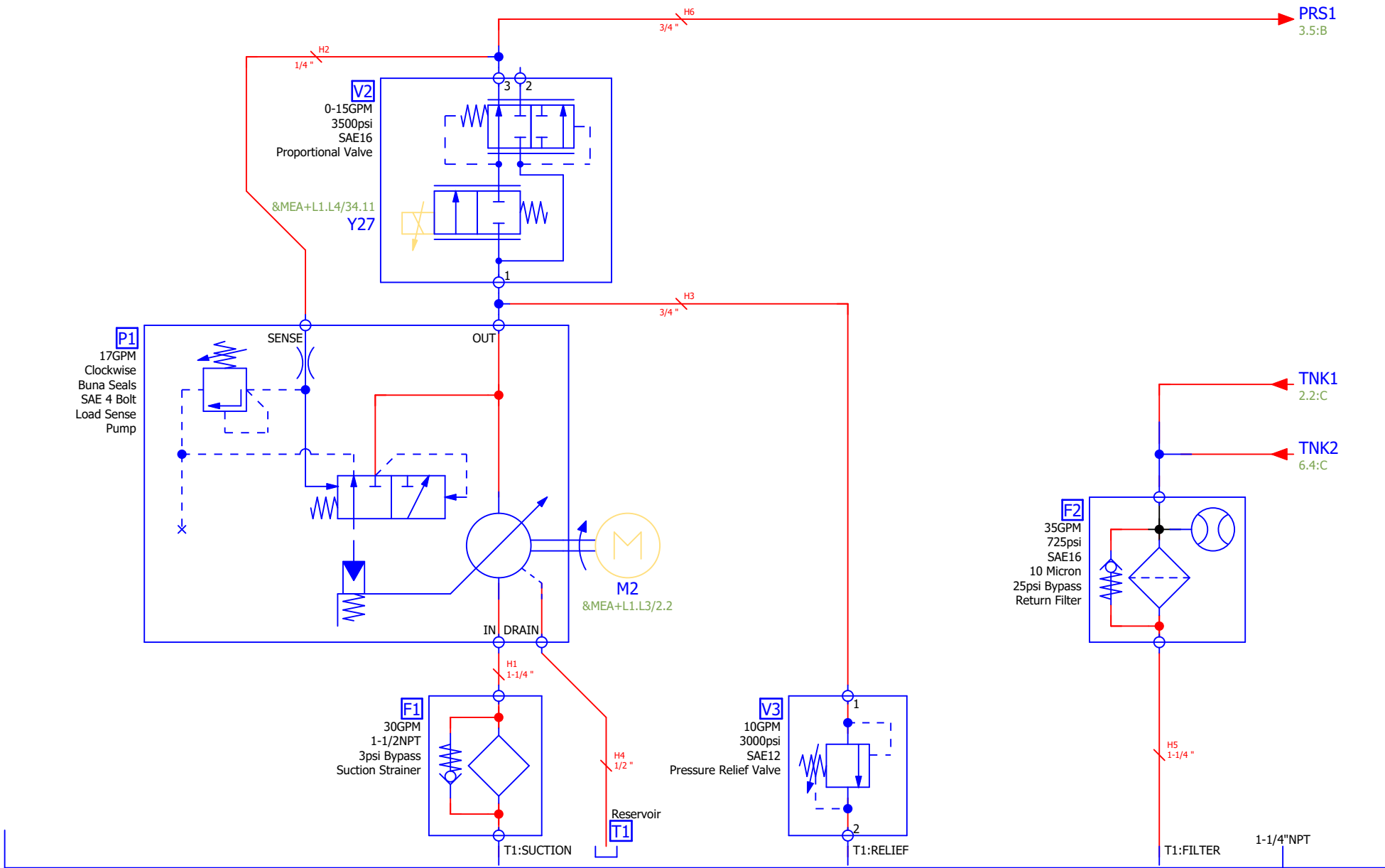

Wood-Mizer®

Project Description: WM4500 Standard

Revision:	A4.04	Pg Desc: Hydraulic Pump
Mounting Location: +L9	Type: Fluid power schematic	
Prev. pg: +/B1	Page: 1	Next pg: 2
		Total Pgs: 89

A

B

C

D

E

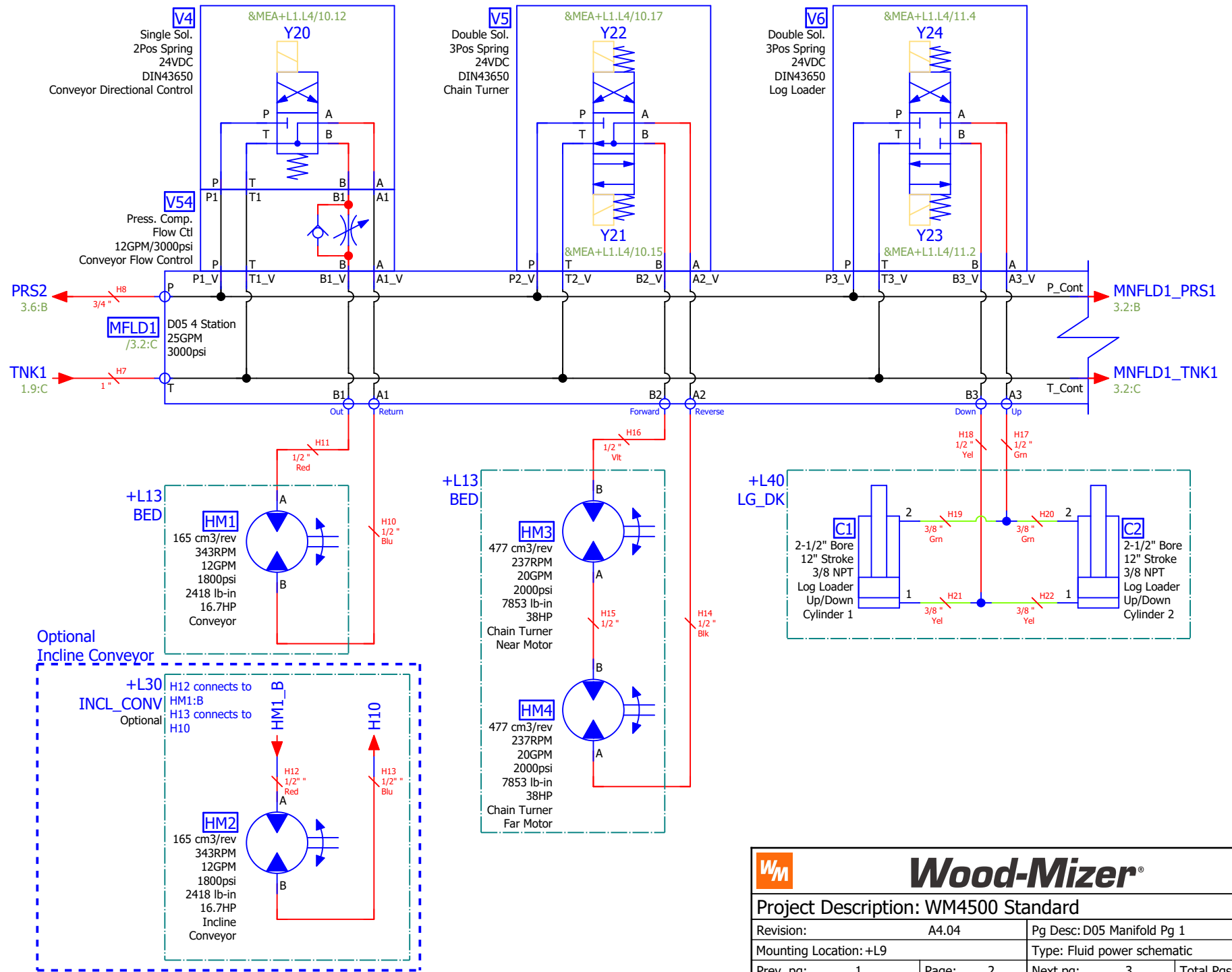

A

B

C

D

E

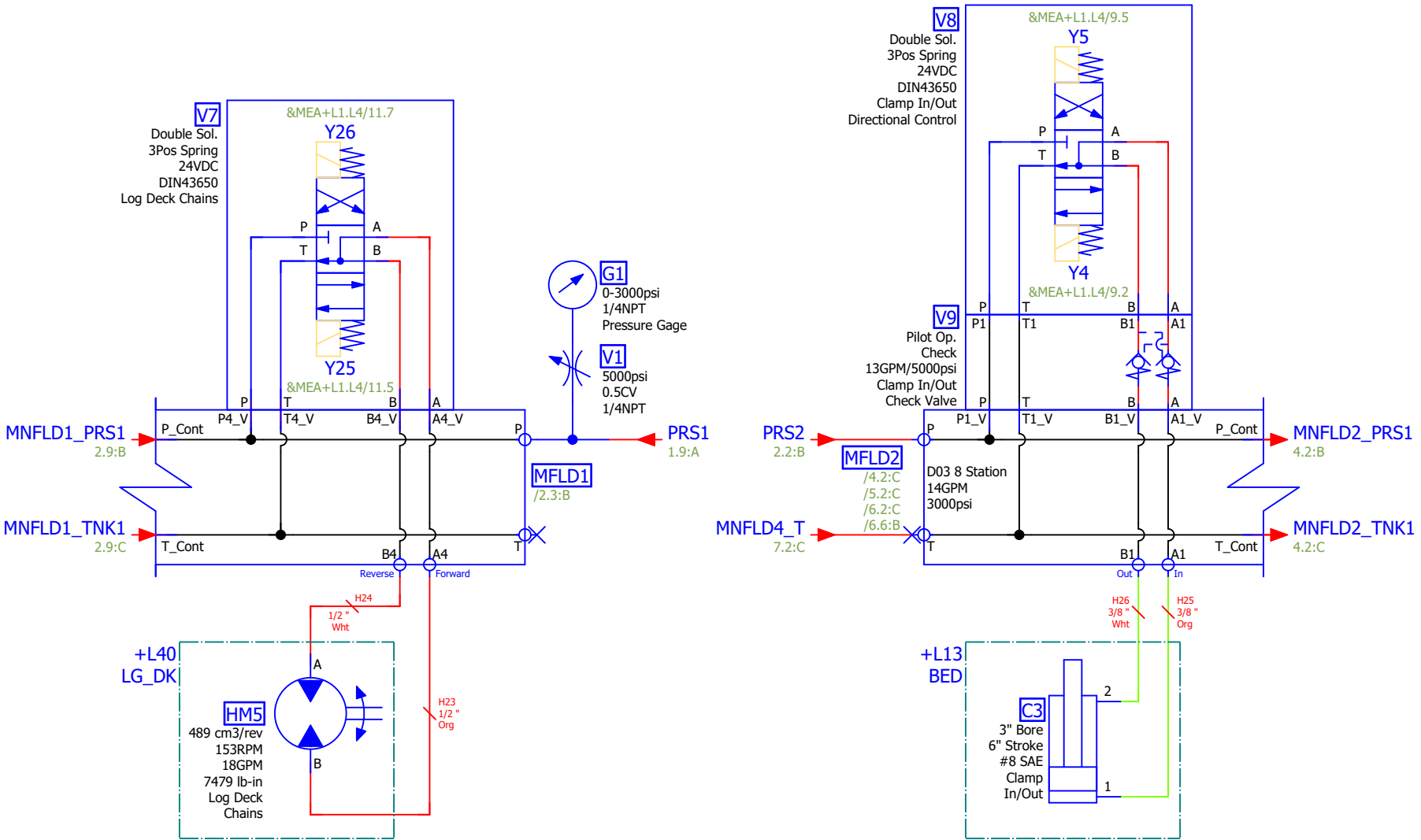

		<h2>Wood-Mizer®</h2>	
		Project Description: WM4500 Standard	
Revision:	A4.04	Pg Desc: D05 Manifold Pg 2	
Mounting Location:	+L9	Type: Fluid power schematic	
Prev. pg:	2	Page:	3
		Next pg:	4
		Total Pgs:	89

A

B

C

D

E

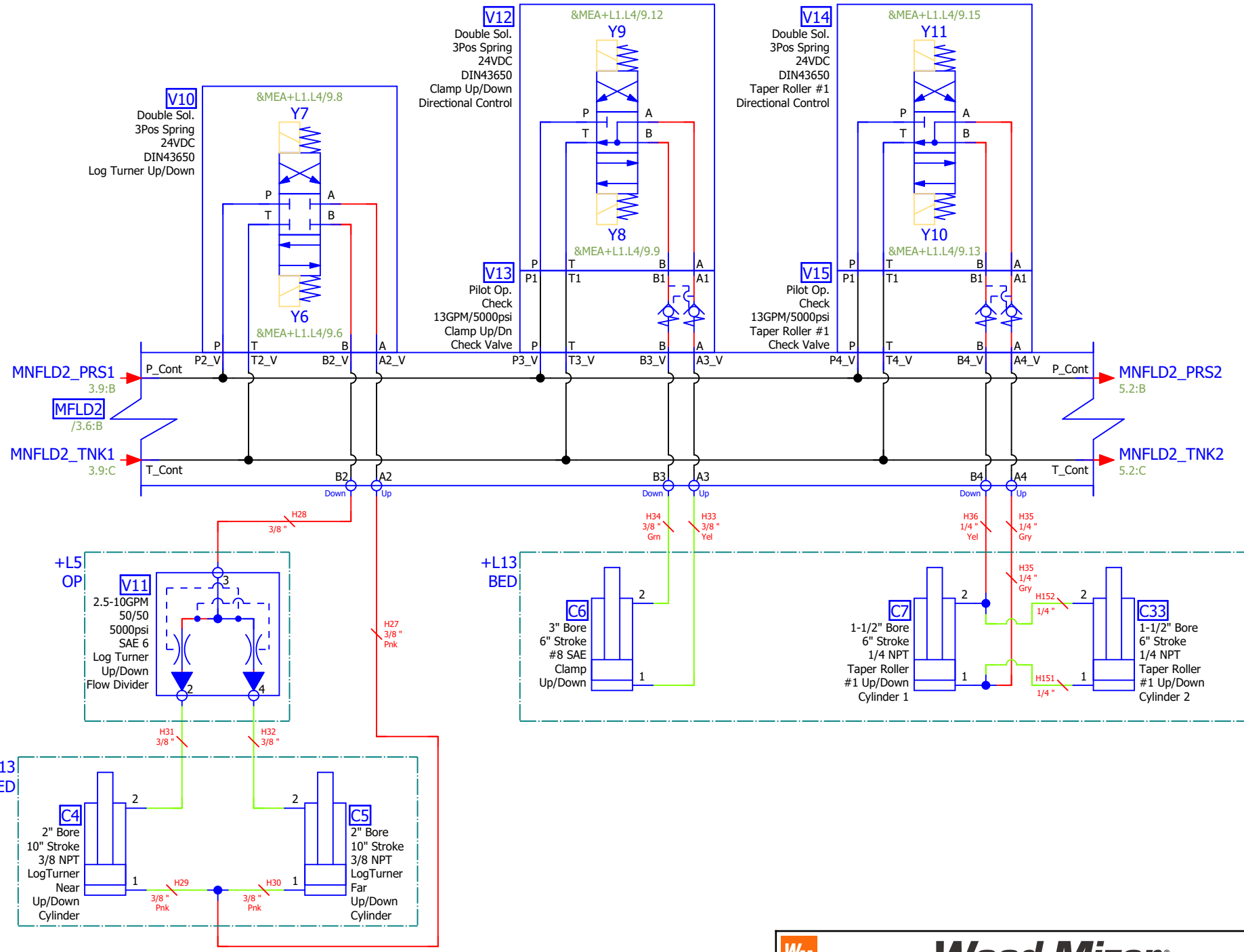

WM **Wood-Mizer®**

Project Description: WM4500 Standard

Revision: A4.04	Pg Desc: D03 Manifold Pg 1
Mounting Location: +L9	Type: Fluid power schematic
Prev. pg: 3	Page: 4
Next pg: 5	Total Pgs: 89

A

B

C

D

E

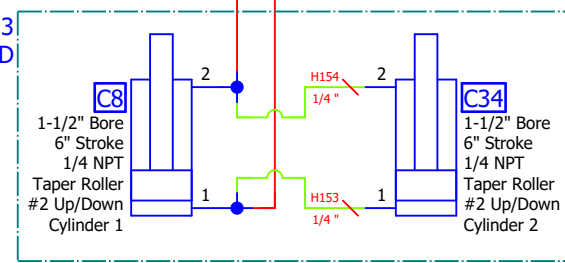
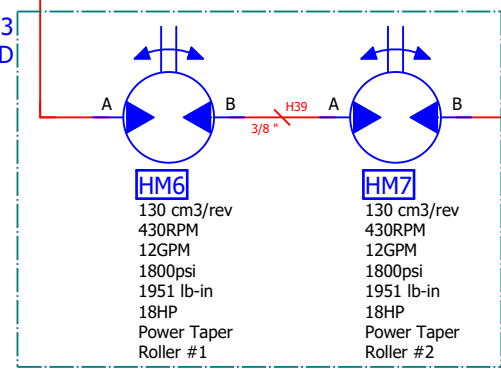
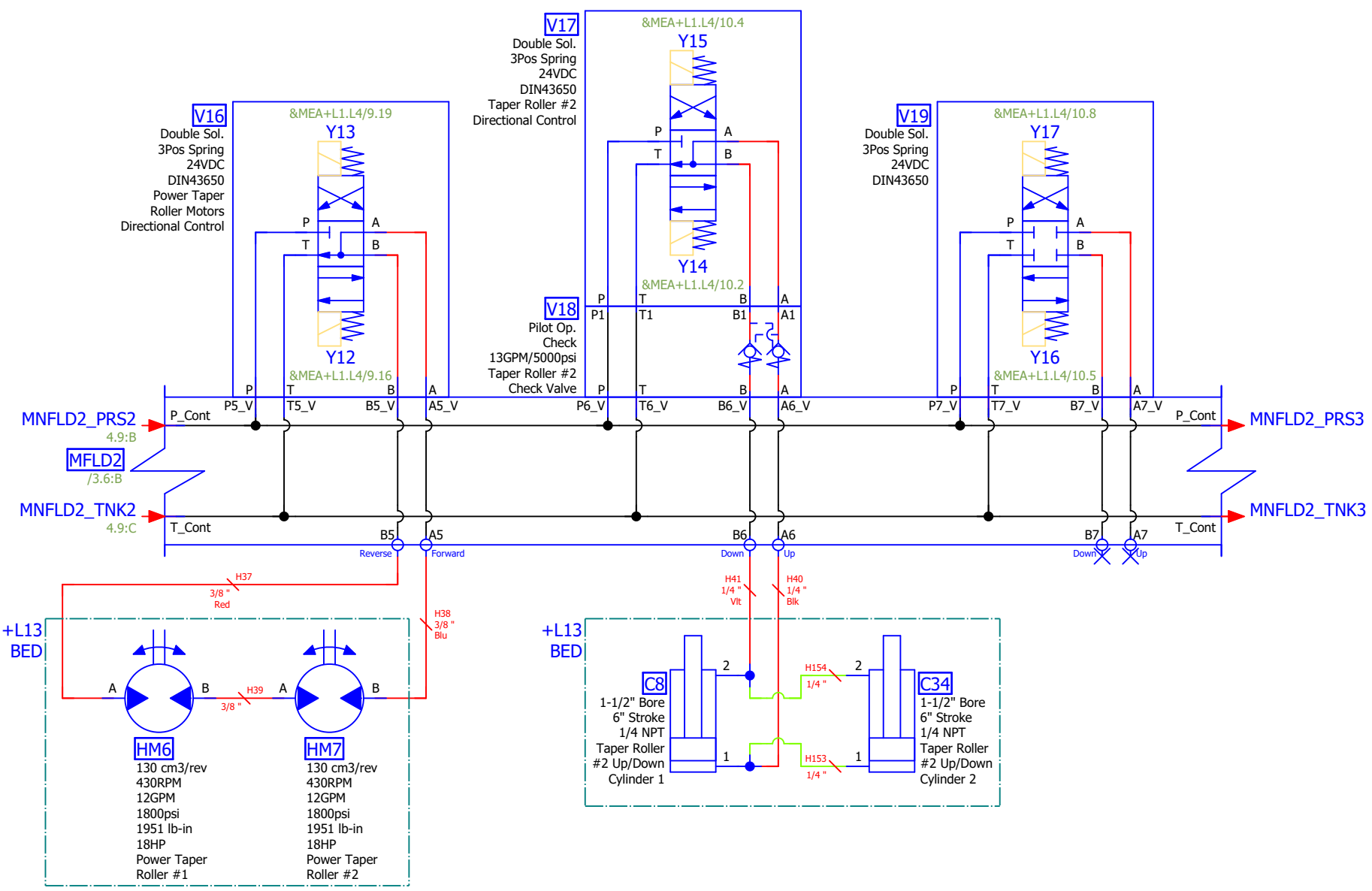

A

B

C

D

E

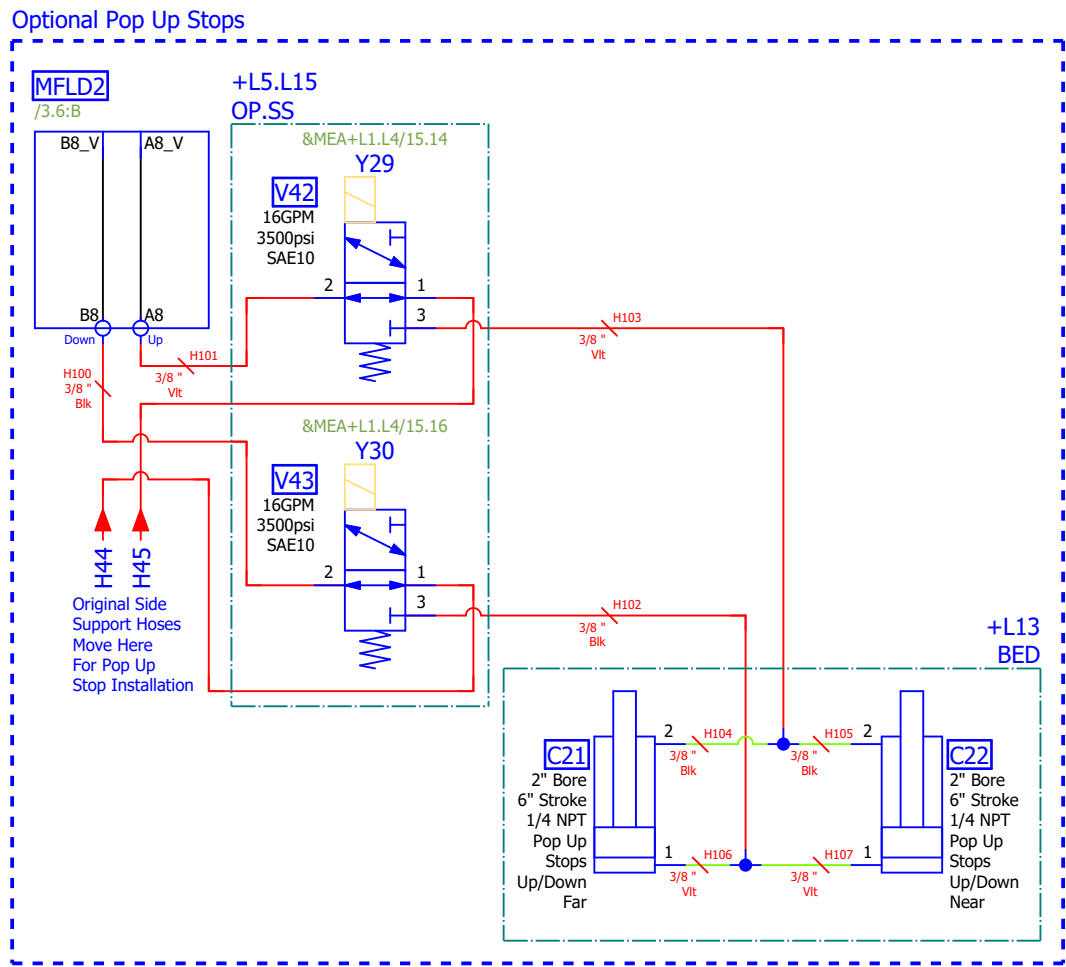
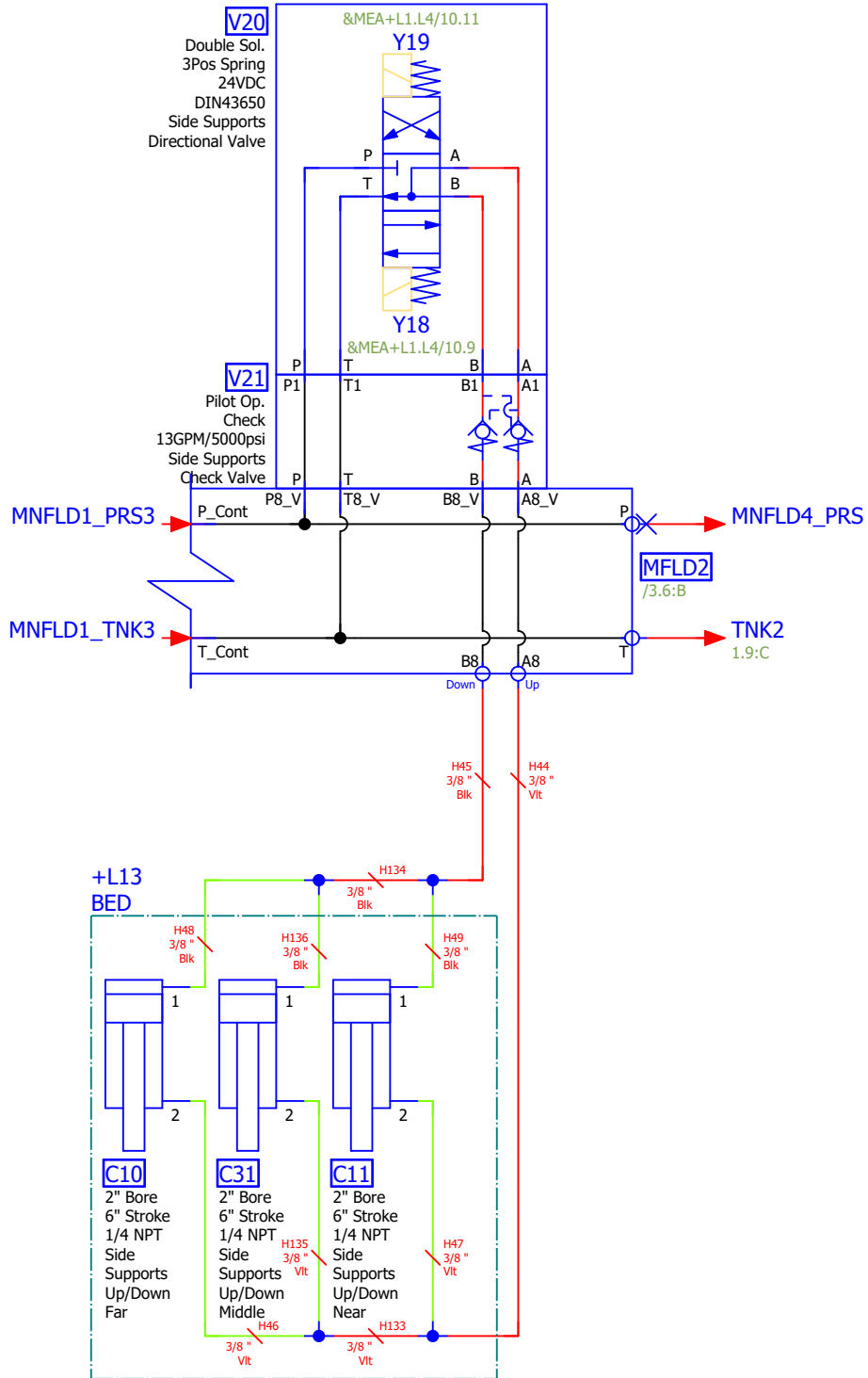

WM **Wood-Mizer®**

Project Description: WM4500 Standard

Revision:	A4.04	Pg Desc: D03 Manifold Pg 3
Mounting Location:	+L9	Type: Fluid power schematic
Prev. pg:	5	Page: 6
		Next pg: 7
		Total Pgs: 89

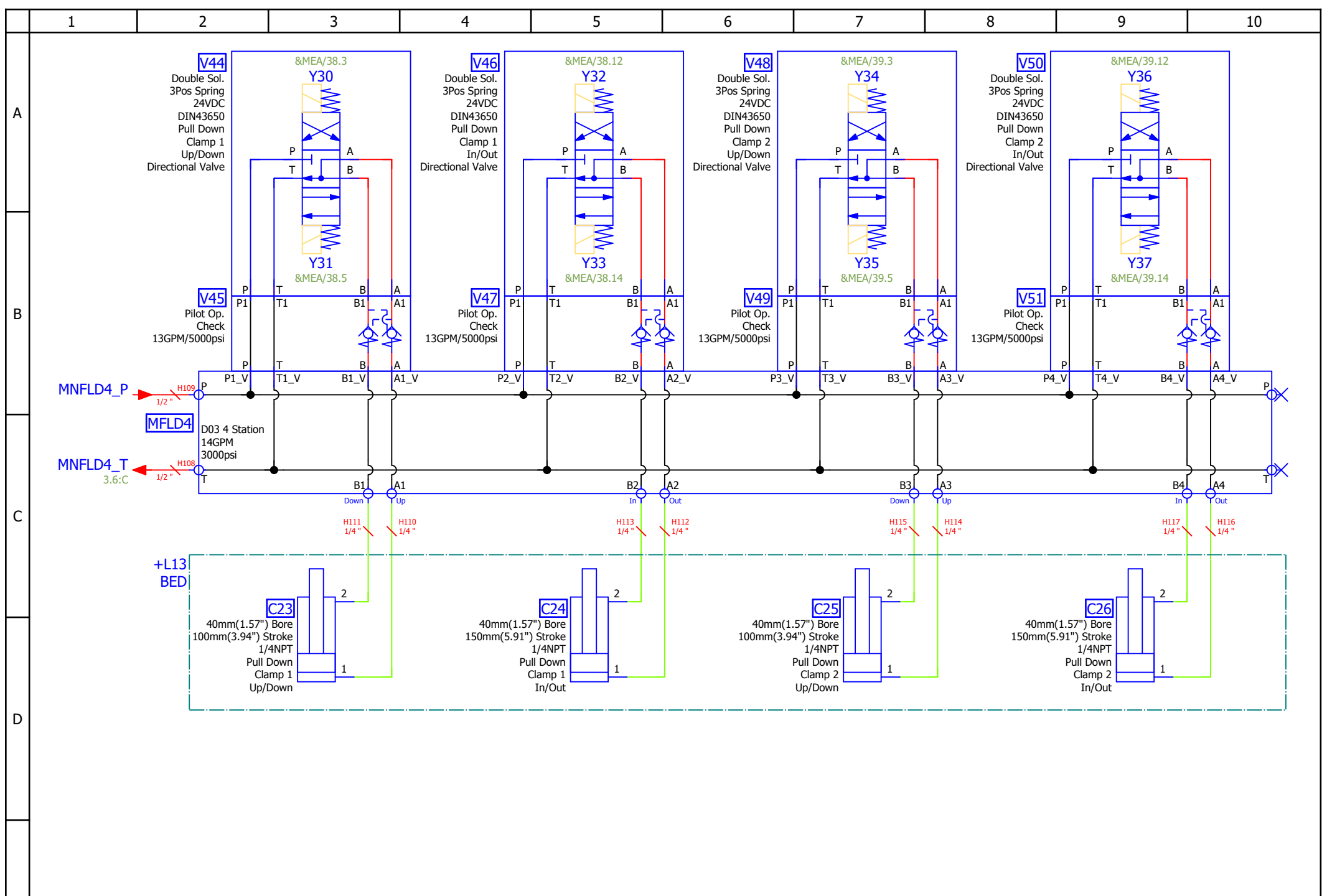

Device Tag/Parts List

WM_PARTS_LIST_Fluid-Manual

Device tag	Function	Wood-Mizer Part Number	Wood-Mizer Description		Qty.	X-Ref
C1	Log Loader Up/Down Cylinder 1	050105	Cylinder, 2-1/2 Bore x 12x221/4		1	+L9/2.208:AC
C1	=	P12955	Seal Kit, 2 1/2x8 Hydraulic Cylinder	Replacement Seals	1	+L9/2.208:AC
C2	Log Loader Up/Down Cylinder 2	050105	Cylinder, 2-1/2 Bore x 12x221/4		1	+L9/2.209:AC
C2	=	P12955	Seal Kit, 2 1/2x8 Hydraulic Cylinder	Replacement Seals	1	+L9/2.209:AC
C3	Clamp In/Out	062700	Cylinder, Hyd 3x6		1	+L9/3.308:AC
C4	LogTurner Near Up/Down Cylinder	034267	Cylinder, 2x10 Rod End Welded 16"		1	+L9/4.402:AD
C4	=	003814	Seal Kit, Hyd Cylinder, 2x10 (034267)	Replacement Seals	1	+L9/4.402:AD
C5	LogTurner Far Up/Down Cylinder	034267	Cylinder, 2x10 Rod End Welded 16"		1	+L9/4.403:AD
C5	=	003814	Seal Kit, Hyd Cylinder, 2x10 (034267)	Replacement Seals	1	+L9/4.403:AD
C6	Clamp Up/Down	062700	Cylinder, Hyd 3x6		1	+L9/4.406:AC
C7	Taper Roller #1 Up/Down Cylinder 1	014482	Cylinder, 1 1/2x6 Rod End In Line Ports		1	+L9/4.408:AC
C7	=	014547	Seal Kit, 1 1/2x6 Hyd Cyl	Replacement Seals	1	+L9/4.408:AC
C8	Taper Roller #2 Up/Down Cylinder 1	014482	Cylinder, 1 1/2x6 Rod End In Line Ports		1	+L9/5.506:AC
C8	=	014547	Seal Kit, 1 1/2x6 Hyd Cyl	Replacement Seals	1	+L9/5.506:AC
C10	Side Supports Up/Down Far	035625	Cylinder, 2x6, 1/4 NPT Port		1	+L9/6.602:AD
C10	=	003812	Seal Kit, Hyd Cylinder, 2x6 (035625)	Replacement Seals	1	+L9/6.602:AD
C11	Side Supports Up/Down Near	035625	Cylinder, 2x6, 1/4 NPT Port		1	+L9/6.603:AD
C11	=	003812	Seal Kit, Hyd Cylinder, 2x6 (035625)	Replacement Seals	1	+L9/6.603:AD
C21	Pop Up Stops Up/Down Far	035625	Cylinder, 2x6, 1/4 NPT Port		1	+L9/6.609:AD
C21	=	003812	Seal Kit, Hyd Cylinder, 2x6 (035625)	Replacement Seals	1	+L9/6.609:AD
C22	Pop Up Stops Up/Down Near	035625	Cylinder, 2x6, 1/4 NPT Port		1	+L9/6.609:AD
C22	=	003812	Seal Kit, Hyd Cylinder, 2x6 (035625)	Replacement Seals	1	+L9/6.609:AD
C23	Pull Down Clamp 1 Up/Down	088662	CYLINDER, CJ7F-16-40/22/100 Dz + UE2-40W		1	+L9/7.703:AC
C24	Pull Down Clamp 1 In/Out	088661	CYLINDER, SJ2F-16-40/22/150 HYDRAULIC		1	+L9/7.705:AC
C25	Pull Down Clamp 2 Up/Down	088662	CYLINDER, CJ7F-16-40/22/100 Dz + UE2-40W		1	+L9/7.707:AC
C26	Pull Down Clamp 2 In/Out	088661	CYLINDER, SJ2F-16-40/22/150 HYDRAULIC		1	+L9/7.709:AC
C31	Side Supports Up/Down Middle	035625	Cylinder, 2x6, 1/4 NPT Port		1	+L9/6.602:AD
C31	=	003812	Seal Kit, Hyd Cylinder, 2x6 (035625)	Replacement Seals	1	+L9/6.602:AD
C33	Taper Roller #1 Up/Down Cylinder 2	014482	Cylinder, 1 1/2x6 Rod End In Line Ports		1	+L9/4.409:AC
C33	=	014547	Seal Kit, 1 1/2x6 Hyd Cyl	Replacement Seals	1	+L9/4.409:AC
C34	Taper Roller #2 Up/Down Cylinder 2	014482	Cylinder, 1 1/2x6 Rod End In Line Ports		1	+L9/5.507:AC
C34	=	014547	Seal Kit, 1 1/2x6 Hyd Cyl	Replacement Seals	1	+L9/5.507:AC
F1	Suction Strainer	078690	Strainer, Suction w/Bypass		1	+L9/1.104:AD
F2	Return Filter	078395	Filter, Hyd Cstr 35GPM 725psi wind SAE16		1	+L9/1.108:AC
F2	=	078341	Filter, Hyd. Element 10 Micron 25psi Byp	Replacement Element	1	+L9/1.108:AC
G1	Pressure Gage	068265	Gauge, Pressure VPG25N3KL		1	+L9/3.304:AB
HM1	Conveyor	P20206	Motor, Hydraulic, TB0165FP100AAAA		1	+L9/2.203:AD
HM1	=	061136	Kit, Hydraulic Motor Seal	Replacement Seals	1	+L9/2.203:AD
HM2	Incline Conveyor	P20206	Motor, Hydraulic, TB0165FP100AAAA		1	+L9/2.203:AE
HM2	=	061136	Kit, Hydraulic Motor Seal	Replacement Seals	1	+L9/2.203:AE
HM3	Chain Turner Near Motor	007331	Motor, Hydraulic, TG0475US0800AAFU		1	+L9/2.206:AC
HM4	Chain Turner Far Motor	007331	Motor, Hydraulic, TG0475US0800AAFU		1	+L9/2.206:AD
HM5	Log Deck Chains	056062	Motor, Hyd Log Deck		1	+L9/3.303:AC
HM6	Power Taper Roller #1	074281	Motor, Hydraulic, TB0130FP130AAAA		1	+L9/5.502:AD
HM6	=	061136	Kit, Hydraulic Motor Seal	Replacement Seals	1	+L9/5.502:AD
HM7	Power Taper Roller #2	074281	Motor, Hydraulic, TB0130FP130AAAA		1	+L9/5.503:AD

		Wood-Mizer®	
Project Description: WM4500 Standard			
Revision:	A4.04	Pg Desc: Parts list - Standard Bed	
Mounting Location:	+Docs	Type: Parts list	
Prev. pg:	+L9/7	Page:	C1
Next pg:	C2	Total Pgs:	89

Device Tag/Parts List

WM_PARTS_LIST_Fluid-Manual

Device tag	Function	Wood-Mizer Part Number	Wood-Mizer Description		Qty.	X-Ref
HM7	Power Taper Roller #2	061136	Kit, Hydraulic Motor Seal	Replacement Seals	1	+L9/5.503:AD
MFLD1	D05 Power Unit Manifold	061190	D05, 4 Station Manifold		1	+L9/2.203:AB
MFLD1	=	078399	Plate, Cover D05 Valve	Covers For Optional Log Deck Valve Sections	2	+L9/2.203:AB
MFLD2	D03 Power Unit Manifold	061185	Manifold Shell Only, WM4000 AD03P082S		1	+L9/3.306:AB
MFLD4	D03 Pull Down Clamps Manifold	078885	Manifold, D03 4 Station AI SAE		1	+L9/7.702:AB
P1	Pump	078671	Pump, Hyd. 17GPM Piston Load Sense		1	+L9/1.102:AB
P1	=	078397	Adapter, C-Face Pump Mtr SAE B	Pump Mount	1	+L9/1.102:AB
P1	=	068252	Coupling, Pump		1	+L9/1.102:AB
P1	=	068253	Coupling, Motor		1	+L9/1.102:AB
P1	=	068254	Coupling, Insert		1	+L9/1.102:AB
V1	Pressure Gage Needle Valve	068264	Valve, Snubber MFG250BF		1	+L9/3.304:AB
V2	Proportional Valve	068273	Valve, Proportional PV72-30A	Complete Valve Assembly	1	+L9/1.103:AA
V2	=	061290	Block, Valve Body HF 7022350	Valve Body Only	1	+L9/1.103:AA
V2	=	078185	Valve, Proportional 15GPM PV72-30A	Valve Cartridge Only	1	+L9/1.103:AA
V2	=	068257	Valve, Proportional Cartridge PV72-30A	Valve Cartridge w/Coil	1	+L9/1.103:AA
V3	Pressure Relief Valve	078735	Valve, Relief 250-3000psi RV10-20A Cmplt	Complete Valve Assembly	1	+L9/1.106:AD
V3	=	078672	Valve, Body 10 Size 2-Way SAE 12	Valve Body Only	1	+L9/1.106:AD
V3	=	078673	Valve, Relief 250-3000psi RV10-20A Ctg	Valve Cartridge Only	1	+L9/1.106:AD
V4	Conveyor Directional Control	078686	Valve, D05 2Pos A-B Tank		1	+L9/2.203:AA
V5	Chain Turner	078685	Valve, D05 3Pos A-B Tank		1	+L9/2.205:AA
V6	Log Loader	078685	Valve, D05 3Pos A-B Tank		1	+L9/2.207:AA
V7	Log Deck Chains	078685	Valve, D05 3Pos A-B Tank		1	+L9/3.302:AA
V8	Clamp In/Out Directional Control	078683	Valve, D03 3Pos A-B Tank		1	+L9/3.307:AA
V9	Clamp In/Out Check Valve	078738	Valve, D03 PO Check		1	+L9/3.307:AB
V10	Log Turner Up/Down	078684	Valve, D03 3Pos Blocked		1	+L9/4.403:AA
V11	Log Turner Up/Down Flow Divider	025742	Flow Divider, Hydraulic		1	+L9/4.402:AC
V12	Clamp Up/Down Directional Control	078683	Valve, D03 3Pos A-B Tank		1	+L9/4.405:AA
V13	Clamp Up/Dn Check Valve	078738	Valve, D03 PO Check		1	+L9/4.405:AB
V14	Taper Roller #1 Directional Control	078683	Valve, D03 3Pos A-B Tank		1	+L9/4.407:AA
V15	Taper Roller #1 Check Valve	078738	Valve, D03 PO Check		1	+L9/4.407:AB
V16	Power Taper Roller Motors Directional Control	078683	Valve, D03 3Pos A-B Tank		1	+L9/5.503:AA
V17	Taper Roller #2 Directional Control	078683	Valve, D03 3Pos A-B Tank		1	+L9/5.505:AA
V18	Taper Roller #2 Check Valve	078738	Valve, D03 PO Check		1	+L9/5.505:AB
V19		078684	Valve, D03 3Pos Blocked		1	+L9/5.507:AA
V20	Side Supports Directional Valve	078685	Valve, D05 3Pos A-B Tank		1	+L9/6.602:AA
V21	Side Supports Check Valve	078738	Valve, D03 PO Check		1	+L9/6.602:AB
V42	Side Supports Up Selector	074286	Valve, 3-Way Selector		1	+L9/6.607:AC
V42	=	078448	Valve, Spool 3-Way Cartridge	Valve Cartridge Only	1	+L9/6.607:AC
V43	Side Supports Down Selector	074286	Valve, 3-Way Selector		1	+L9/6.607:AD
V43	=	078448	Valve, Spool 3-Way Cartridge	Valve Cartridge Only	1	+L9/6.607:AD
V44	Pull Down Clamp 1 Up/Down Directional Valve	078685	Valve, D05 3Pos A-B Tank		1	+L9/7.702:AA
V45	Pull Down Clamp 1 Up/Down Check Valve	078738	Valve, D03 PO Check		1	+L9/7.702:AB
V46	Pull Down Clamp 1 In/Out Directional Valve	078685	Valve, D05 3Pos A-B Tank		1	+L9/7.704:AA
V47	Pull Down Clamp 1 In/Out Check Valve	078738	Valve, D03 PO Check		1	+L9/7.704:AB
V48	Pull Down Clamp 2 Up/Down Directional Valve	078685	Valve, D05 3Pos A-B Tank		1	+L9/7.706:AA
V49	Pull Down Clamp 2 Up/Down Check Valve	078738	Valve, D03 PO Check		1	+L9/7.706:AB

		Wood-Mizer®	
Project Description: WM4500 Standard			
Revision: A4.04		Pg Desc: Parts list - Standard Bed	
Mounting Location: +Docs		Type: Parts list	
Prev. pg: C1	Page: C2	Next pg: C3	Total Pgs: 89

Device Tag/Parts List

WM_PARTS_LIST_Fluid-Manual

Device tag	Function	Wood-Mizer Part Number	Wood-Mizer Description		Qty.	X-Ref
V50	Pull Down Clamp 2 In/Out Directional Valve	078685	Valve, D05 3Pos A-B Tank		1	+L9/7.708:AA
V51	Pull Down Clamp 2 In/Out Check Valve	078738	Valve, D03 PO Check		1	+L9/7.708:AB
V54	Conveyor Flow Control	078737	Valve, Press Comp Flow Ctl 12GPM Cmplt		1	+L9/2.203:AB
V54	=	078681	Valve Body, D05 Sandwich Flow Ctl Port B	Valve Body Only	1	+L9/2.203:AB
V54	=		Valve, Press Comp Flow Ctl 12GPM	Valve Cartridge Only	1	+L9/2.203:AB

		Wood-Mizer®	
Project Description: WM4500 Standard			
Revision:	A4.04	Pg Desc: Parts list - Standard Bed	
Mounting Location:	+Docs	Type: Parts list	
Prev. pg:	C2	Page:	C3
Next pg:	K1	Total Pgs:	89

Hose/Tube list

WM_HydraulicHoseList

Hose/Tube	Wood-Mizer PN	Color	Diameter	Length	Description	XREF
H1	078736		1-1/4 "		Suction Tube	+L9/1.104:AD
H2	078761		1/4 "		Load Sense Line	+L9/1.104:AA
H3	078760		3/4 "		Pressure Relief Line	+L9/1.104:AB
H4	078767		1/2 "		Pump Case Drain	+L9/1.105:AD
H5	078767		1-1/4 "		Filter Tank Line	+L9/1.109:AD
H6	078760		3/4 "		Pressure Line From Proportional Valve	+L9/3.304:AB
H7	078760		1 "		Tank Line From Manifold 1	+L9/1.109:AC
H8	078763		3/4 "		Pressure Line Manifold 1 To Manifold 2	+L9/2.203:AB
H10	079004-471	Blu	1/2 "	471"	Conveyor Return Line	+L9/2.203:AD
H11	079004-471	Red	1/2 "	471"	Conveyor Out Line	+L9/2.203:AD
H12	079004-156	Red	1/2" "	156"	Incline Conveyor Out	+L9/2.203:AE
H13	079004-156	Blu	1/2" "	156"	Incline Conveyor Return	+L9/2.204:AE
H14	079004-334	Blk	1/2 "	334"	Turner (Far) Motor	+L9/2.206:AD
H15	079004-132		1/2 "	132"	Turner (Near) Motor to Turner (Far) Motor	+L9/2.206:AC
H16	079004-350	Vlt	1/2 "	350"	Turner (Near) Motor	+L9/2.206:AC
H17	079004-310	Grn	1/2 "	310"	Log Loader Up T	+L9/2.208:AC
H18	079004-310	Yel	1/2 "	310"	Log Loader Down T	+L9/2.208:AD
H19	079001-72	Grn	3/8 "	72"	Log Loader Up T to C1	+L9/2.208:AC
H20	079001-72	Grn	3/8 "	72"	Log Loader Up T to C2	+L9/2.208:AC
H21	079001-72	Yel	3/8 "	72"	Log Loader Down T to C1	+L9/2.208:AD
H22	079001-72	Yel	3/8 "	72"	Log Loader Down T to C2	+L9/2.208:AD
H23	079004-310	Org	1/2 "	310"	Log Deck Forward Line	+L9/3.303:AC
H24	079004-310	Wht	1/2 "	310"	Log Deck Reverse Line	+L9/3.303:AC
H25	079001-364	Org	3/8 "	364"	Clamp In Line	+L9/3.308:AC
H26	079001-364	Wht	3/8 "	364"	Clamp Out Line	+L9/3.308:AC
H27	079001-275	Pnk	3/8 "	275"	Log Turner Up T	+L9/4.403:AE
H28	079001-85		3/8 "	85"	Log Turner Down Flow Divider	+L9/4.404:AC
H29	079001-19	Pnk	3/8 "	19"	Log Turner Up T To Cylinder Near	+L9/4.403:AE
H30	079001-39	Pnk	3/8 "	39"	Log Turner Up T To Cylinder Far	+L9/4.403:AE
H31	079001-200		3/8 "	200"	Log Turner Down FD2 To Cylinder Near	+L9/4.402:AD
H32	079001-216		3/8 "	216"	Log Turner Down FD4 To Cylinder Far	+L9/4.403:AD
H33	079001-364	Yel	3/8 "	364"	Clamp Up Line	+L9/4.406:AC
H34	079001-364	Grn	3/8 "	364"	Clamp Down Line	+L9/4.406:AC
H35	079000-267	Gry	1/4 "	267"	Taper Roller #1 Up Line	+L9/4.408:AD
H36	079000-270	Yel	1/4 "	270"	Taper Roller #1 Down Line	+L9/4.408:AC
H37	079001-276	Red	3/8 "	276"	Power Toe Roller #1 Motor	+L9/5.502:AD
H38	079001-348	Blu	3/8 "	348"	Power Toe Roller #2 Motor	+L9/5.503:AD
H39	079001-154		3/8 "	154"	Power Toe Roller #1 Motor to #2 Motor	+L9/5.502:AD
H40	079000-333	Blk	1/4 "	333"	Taper Roller #2 Up Line	+L9/5.506:AD



Wood-Mizer®

Project Description: WM4500 Standard

Revision:	A4.04	Pg Desc:	Hose/Tube List-Standard Bed
Mounting Location:	+Docs	Type:	Connection list
Prev. pg:	C3	Page:	K1
Next pg:	K2	Total Pgs:	89

Hose/Tube list

WM_HydraulicHoseList

Hose/Tube	Wood-Mizer PN	Color	Diameter	Length	Description	XREF
H41	079000-335	Vlt	1/4 "	3358"	Taper Roller #2 Down Line	+L9/5.506:AC
H44	079001-190	Vlt	3/8 "	190"	Side Supports Down T1	+L9/6.603:AE
H45	079001-190	Blk	3/8 "	190"	Side Supports Up T1	+L9/6.603:AD
H46	079001-120	Vlt	3/8 "	120"	Side Supports Up T2 to Far Cylinder	+L9/6.602:AE
H47	079001-51	Vlt	3/8 "	51"	Side Supports Up T1 to Near Cylinder	+L9/6.603:AE
H48	079001-122	Blk	3/8 "	122"	Side Supports Down T2 to Far Cylinder	+L9/6.603:AD
H49	079001-51	Blk	3/8 "	51"	Side Supports Down T1 to Near Cylinder	+L9/6.603:AD
H100	079001-190	Blk	3/8 "	190"	Pop Up Stops Down Selector 2	+L9/6.606:AC
H101	079001-41	Vlt	3/8 "	41"	Pop Up Stops Up Selector 2	+L9/6.606:AC
H102	079001-41	Blk	3/8 "	41"	Pop Up Stops Down Selector 3 To T	+L9/6.609:AD
H103	079001-41	Vlt	3/8 "	41"	Pop Up Stops Up Selector 3 To T	+L9/6.609:AD
H104	079001-41	Blk	3/8 "	41"	Pop Up Down T To Cylinder 1	+L9/6.609:AD
H105	079001-41	Blk	3/8 "	41"	Pop Up Down T To Cylinder 2	+L9/6.609:AD
H106	079001-41	Vlt	3/8 "	41"	Pop Up Stops Up T To Cylinder 1	+L9/6.609:AD
H107	079001-41	Vlt	3/8 "	41"	Pop Up Stops Up T To Cylinder 2	+L9/6.609:AD
H108	079004-44		1/2 "	44"	Pull Down Clamps Manifold Tank Line	+L9/3.306:AC
H110	079000-456		1/4 "	456"	Pull Down Clamp 1 Up Line	+L9/7.703:AC
H111	079000-456		1/4 "	456"	Pull Down Clamp 1 Down Line	+L9/7.703:AC
H112	079000-456		1/4 "	456"	Pull Down Clamp 1 Out Line	+L9/7.705:AC
H113	079000-456		1/4 "	456"	Pull Down Clamp 1 In Line	+L9/7.705:AC
H114	079000-336		1/4 "	336"	Pull Down Clamp 2 Up Line	+L9/7.707:AC
H115	079000-336		1/4 "	336"	Pull Down Clamp 2 Down Line	+L9/7.707:AC
H116	079000-336		1/4 "	336"	Pull Down Clamp 2 Out Line	+L9/7.709:AC
H117	079000-336		1/4 "	336"	Pull Down Clamp 2 In Line	+L9/7.709:AC
H133	079001-41	Vlt	3/8 "	41"	Side Supports Up T1 To T2	+L9/6.602:AE
H134	079001-41	Blk	3/8 "	41"	Side Supports Down T1 To T2	+L9/6.603:AD
H135	079001-55	Vlt	3/8 "	55"	Side Supports Up T2 to Middle Cylinder	+L9/6.602:AE
H136	079001-59	Blk	3/8 "	59"	Side Supports Down T2 to Middle Cylinder	+L9/6.603:AD
H151	079000-		1/4 "		Taper Roller #1 Up Line 2	+L9/4.408:AD
H152	079000-		1/4 "		Taper Roller #1 Down Line 2	+L9/4.408:AC
H153	079000-		1/4 "		Taper Roller #2 Up Line 2	+L9/5.506:AD
H154	079000-		1/4 "		Taper Roller #2 Down Line 2	+L9/5.506:AC

		Wood-Mizer®	
Project Description: WM4500 Standard			
Revision:	A4.04	Pg Desc: Hose/Tube List-Standard Bed	
Mounting Location: +Docs		Type: Connection list	
Prev. pg:	K1	Page:	K2
Next pg: &MPA+/A1		Total Pgs: 89	

Revision History

Date	Revision	Revision Record	Drawn By	Checked By
8/6/18	A1.00	Release to production	JRF	SDC

		Wood-Mizer®	
Project Description: WM4500 Standard			
Revision: A4.04		Pg Desc: Revision History	
Mounting Location: +		Type: Overview	
Prev. pg: A1	Page: B1	Next pg: +L11.L12/1	Total Pgs: 89

A

B

C

D

E

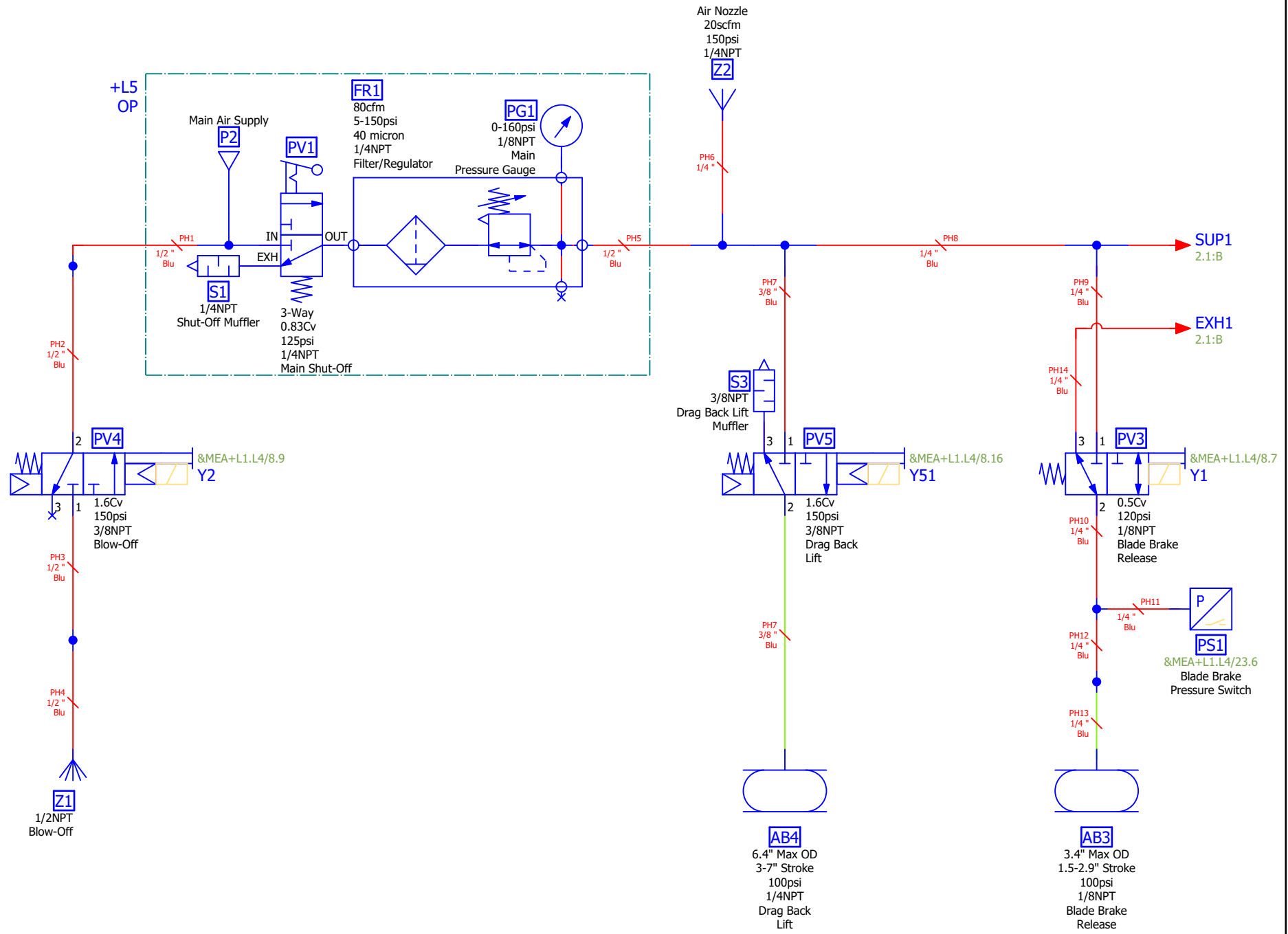

WM **Wood-Mizer®**

Project Description: WM4500 Standard

Revision: A4.04	Pg Desc: Pnuematics Pg 1
Mounting Location: +L11.L12	Type: Fluid power schematic
Prev. pg: +/B1	Page: 1
Next pg: 2	Total Pgs: 89

A

B

C

D

E

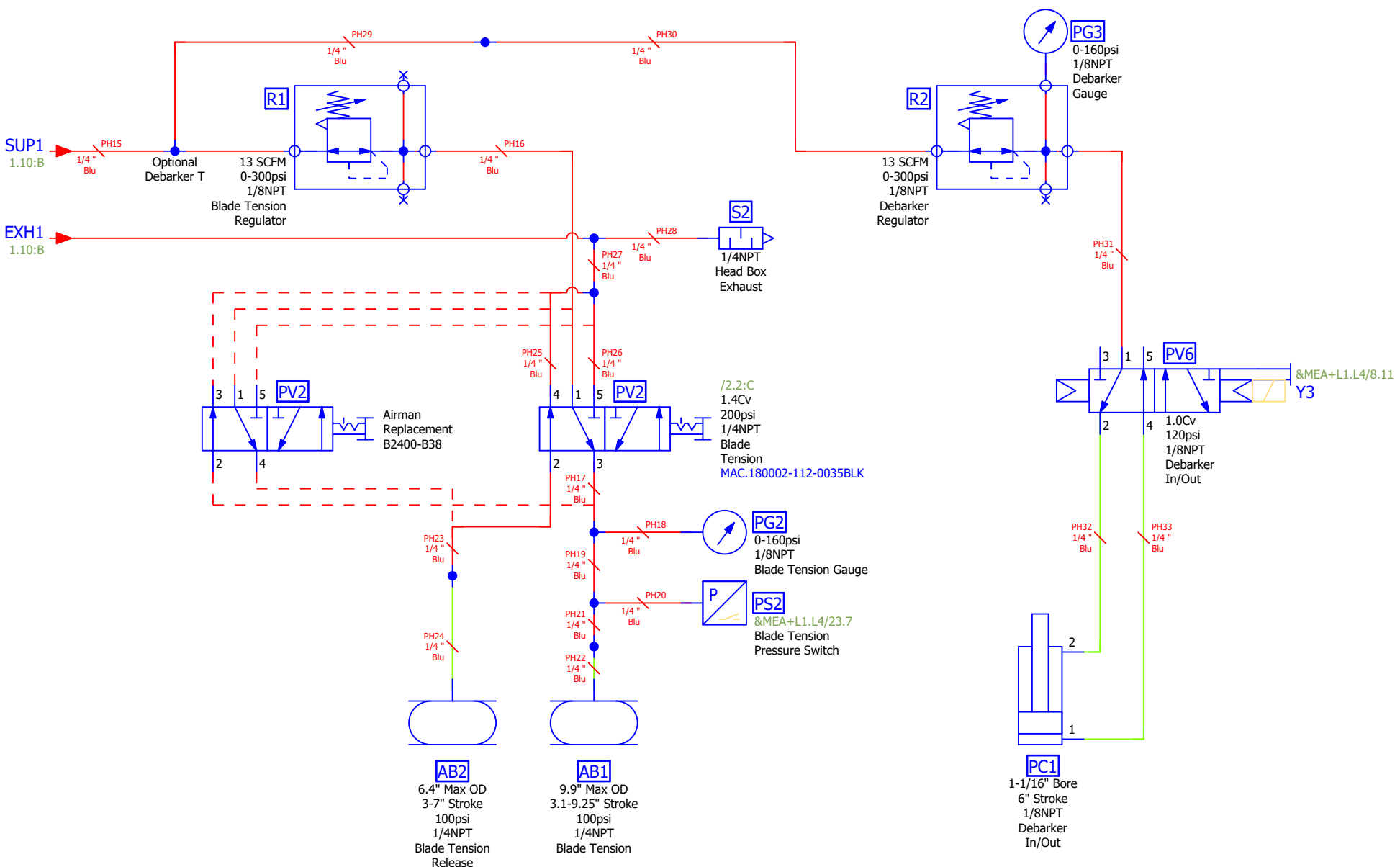

Wood-Mizer®			
Project Description: WM4500 Standard			
Revision:	A4.04	Pg Desc: Pnuematics Pg 2	
Mounting Location:	+L11.L12	Type: Fluid power schematic	
Prev. pg:	1	Page:	2
		Next pg:	+Docs/C1
		Total Pgs:	89

Device Tag/Parts List

WM_PARTS_LIST_Fluid-Manual

Device tag	Function	Wood-Mizer Part Number	Wood-Mizer Description		Qty.	X-Ref
AB1	Blade Tension	033229	Bag, Tensioner Air		1	+L11.L12/2.205:AD
AB2	Blade Tension Release	033231	Bag, Motor Lift Air		1	+L11.L12/2.204:AD
AB3	Blade Brake Release	033168	Bag, Air Brake		1	+L11.L12/1.109:AD
AB4	Drag Back Lift	033231	Bag, Motor Lift Air		1	+L11.L12/1.107:AD
FR1	Filter/Regulator	110953	Air Filter/Regulator		1	+L11.L12/1.104:AA
FR1	=	110956	Assy, Air Filter Mount	Mount	1	+L11.L12/1.104:AA
PC1	Debarker In/Out	008766	Cylinder, 1-1/16x6, Air		1	+L11.L12/2.208:AD
PG1	Main Pressure Gauge	P02766	Gauge, 160 PSI, 1-1/2 Dia, 1/8 NPT		1	+L11.L12/1.106:AA
PG2	Blade Tension Gauge	042342	Gauge, Air Pressure		1	+L11.L12/2.206:AC
PG3	Debarker Gauge	042342	Gauge, Air Pressure		1	+L11.L12/2.208:AA
PV1	Main Shut-Off	P21513	Valve, Air		1	+L11.L12/1.104:AB
PV2	Airman Replacement;Blade Tension	025301	Valve, Push Pull 4 Way 1/4 NPT		2	+L11.L12/2.202:AC +L11.L12/2.205:AC
PV3	Blade Brake Release	045225	Valve, Air 3 Way 1/8 NPT Din C Conn		1	+L11.L12/1.109:AC
PV4	Blow-Off	042659	Valve Assy, Air		1	+L11.L12/1.102:AC
PV5	Drag Back Lift	042659	Valve Assy, Air		1	+L11.L12/1.107:AC
PV6	Debarker In/Out	025244	Valve, MAC 400 Series		1	+L11.L12/2.208:AC
R1	Blade Tension Regulator	052509	Regulator, 1/8" NPT Air		1	+L11.L12/2.203:AB
R2	Debarker Regulator	052509	Regulator, 1/8" NPT Air		1	+L11.L12/2.207:AB
S1	Shut-Off Muffler	P20904	Mufflet, 1/4 in. NPT Air		1	+L11.L12/1.103:AB
S2	Head Box Exhaust	P20904	Mufflet, 1/4 in. NPT Air		1	+L11.L12/2.206:AB
S3	Drag Back Lift Muffler	P21528	Mufflet, CEC-3 3/8 in. NPT Air		1	+L11.L12/1.107:AC
Z1	Blow-Off	016879	Block, Blow-Off 1/2		1	+L11.L12/1.102:AD
Z2	Air Nozzle	P02714	Nozzle, Coolant Spray		1	+L11.L12/1.107:AA

		Wood-Mizer®	
Project Description: WM4500 Standard			
Revision:	A4.04	Pg Desc: Parts list	
Mounting Location:	+Docs	Type: Parts list	
Prev. pg: +L11.L12/2	Page: C1	Next pg: K1	Total Pgs: 89

Hose/Tube list

WM_HydraulicHoseList

Hose/Tube	Wood-Mizer PN	Color	Diameter	Length	Description	XREF
PH1	R01869-5	Blu	1/2 "	960"	Blow-Off Supply Line	+L11.L12/1.102:AB
PH2	R01869-5	Blu	1/2 "	31"	Blow-Off Supply Line Head Box	+L11.L12/1.102:AB
PH3	R01869-5	Blu	1/2 "	33"	Blow-Off Output Line Head Box	+L11.L12/1.102:AD
PH4	R01869-5	Blu	1/2 "		Blow-Off Output Line	+L11.L12/1.102:AD
PH5	R01869-4	Blu	1/2 "	960"	Head Supply Line	+L11.L12/1.106:AB
PH6	042453		1/4 "		Air Nozzle Hose	+L11.L12/1.106:AB
PH7	R01869-4	Blu	3/8 "		Drag Back Fingers Lift Line	+L11.L12/1.107:AD
PH7	R01869-4	Blu	3/8 "	10"	Drag Back Fingers Supply Line	+L11.L12/1.107:AB
PH8	R01869-3	Blu	1/4 "	22"	Supply Line Head Box	+L11.L12/1.109:AB
PH9	R01869-3	Blu	1/4 "	7.5"	Blade Brake Supply Line	+L11.L12/1.109:AB
PH10	R01869-3	Blu	1/4 "	10"	Blade Brake Line Valve To Y	+L11.L12/1.109:AC
PH11	R01869-3	Blu	1/4 "	29.5"	Blade Brake Line Y To Pressure Switch	+L11.L12/1.109:AC
PH12	R01869-3	Blu	1/4 "	6.5"	Blade Brake Line Y To Bulkhead	+L11.L12/1.109:AD
PH13	R01869-3	Blu	1/4 "		Blade Brake Line Bulkhead To Brake	+L11.L12/1.109:AD
PH14	R01869-3	Blu	1/4 "	8.5"	Blade Brake Exhaust Valve To Y	+L11.L12/2.205:AB
PH15	R01869-3	Blu	1/4 "	3"	Blade Tension Supply Y To Regulator	+L11.L12/1.109:AB
PH16	R01869-3	Blu	1/4 "	6.5"	Blade Tension Supply Regulator To Valve	+L11.L12/2.205:AC
PH17	R01869-3	Blu	1/4 "	3"	Blade Tension Line Valve To Pressure Gauge T	+L11.L12/2.205:AC
PH18	R01869-3	Blu	1/4 "	1.5"	Blade Tension Line T To Pressure Gauge	+L11.L12/2.205:AC
PH19	R01869-3	Blu	1/4 "	9"	Blade Tension Line Pressure Gauge T To Pressure Switch Y	+L11.L12/2.205:AD
PH20	R01869-3	Blu	1/4 "	9"	Blade Tension Line Y To Pressure Switch	+L11.L12/2.205:AD
PH21	R01869-3	Blu	1/4 "	10.5"	Blade Tension Line Y To Bulkhead	+L11.L12/2.205:AD
PH22	R01869-3	Blu	1/4 "		Blade Tension Line Bulkhead To Air Bag	+L11.L12/2.205:AD
PH23	R01869-3	Blu	1/4 "	22"	Blade Tension Release Valve To Bulkhead	+L11.L12/2.204:AD
PH24	R01869-3	Blu	1/4 "		Blade Tension Release Bulkhead To Air Bag	+L11.L12/2.204:AD
PH25	R01869-3	Blu	1/4 "	3.5"	Blade Tension Exhaust Valve To Y	+L11.L12/2.205:AB
PH26	R01869-3	Blu	1/4 "	3.5"	Blade Tension Exhaust Valve To Y	+L11.L12/2.205:AB
PH27	R01869-3	Blu	1/4 "	5"	Blade Tension Exhaust Y To Y	+L11.L12/2.205:AB
PH28	R01869-3	Blu	1/4 "	18"	Head Box Exhaust Y To Muffler	+L11.L12/2.205:AB
PH29	R01869-3	Blu	1/4 "		Debarker Supply T To Bulkhead	+L11.L12/2.204:AA
PH30	R01869-3	Blu	1/4 "		Debarker Supply Bulkhead To Regulator	+L11.L12/2.204:AA
PH31	R01869-3	Blu	1/4 "		Debarker Supply Regulator To Valve	+L11.L12/2.208:AC
PH32	R01869-3	Blu	1/4 "		Debarker In Line Valve To Cylinder	+L11.L12/2.208:AD
PH33	R01869-3	Blu	1/4 "		Debarker Out Line Valve To Cylinder	+L11.L12/2.208:AD

		Wood-Mizer®	
Project Description: WM4500 Standard			
Revision:	A4.04	Pg Desc: Hose list	
Mounting Location:	+Docs	Type: Connection list	
Prev. pg:	C1	Page:	K1
Next pg:		Total Pgs:	89