

APPENDIX A ELECTRICAL INFORMATION

WM4500 Rev. A1.00-A1.03 with Optional Pull Down Clamps RETROFIT Kit

Table of contents

WM_TableOfContents

Page	Page type	Page description	Date	Edited by
/A1	Table of contents	Table of contents	5/7/2019	JRF
/A2	Table of contents	Table of contents	5/7/2019	JRF
/A3	Table of contents	Table of contents	5/7/2019	JRF
/B1	Overview	Revision History	4/8/2019	JRF
+L1.L3/1	Schematic multi-line	Power Pg 1	5/7/2019	JRF
+L1.L3/2	Schematic multi-line	Power Pg 2	4/8/2019	JRF
+L1.L3/3	Schematic multi-line	Power Pg 3	5/7/2019	JRF
+L1.L3/4	Schematic multi-line	Control Pg 1	5/7/2019	JRF
+L1.L3/5	Schematic multi-line	Control Pg 2	4/8/2019	JRF
+L1.L3/6	Schematic multi-line	Control Pg 3	5/7/2019	JRF
+L1.L4/7	Schematic multi-line	Control Pg 4	5/7/2019	JRF
+L1.L4/8	Schematic multi-line	Control Pg 5	5/7/2019	JRF
+L1.L4/9	Schematic multi-line	Control Pg 6	5/7/2019	JRF
+L1.L4/10	Schematic multi-line	Control Pg 7	4/8/2019	JRF
+L1.L4/11	Schematic multi-line	Control Pg 8	5/7/2019	JRF
+L1.L4/12	Schematic multi-line	Control Pg 9	5/7/2019	JRF
+L1.L4/13	Schematic multi-line	Control Pg 10	4/8/2019	JRF
+L1.L4/14	Schematic multi-line	Control Pg 11	4/8/2019	JRF
+L1.L4/15	Schematic multi-line	Control Pg 12	5/7/2019	JRF
+L1.L4/16	Schematic multi-line	Control Pg 13	5/7/2019	JRF
+L1.L4/17	Schematic multi-line	Control Pg 14	4/8/2019	JRF
+L1.L4/18	Schematic multi-line	Communication	5/7/2019	JRF
+L1.L4/19	Panel layout	PLC Diagram	4/8/2019	JRF
+L1.L4/20	Schematic multi-line	PLC 1	5/7/2019	JRF
+L1.L4/21	Schematic multi-line	PLC 2	5/7/2019	JRF
+L1.L4/22	Schematic multi-line	PLC 3	5/7/2019	JRF
+L1.L4/23	Schematic multi-line	PLC 4	4/8/2019	JRF
+L1.L4/24	Schematic multi-line	PLC 5	4/8/2019	JRF
+L1.L4/25	Schematic multi-line	PLC 6	5/7/2019	JRF
+L1.L4/26	Schematic multi-line	PLC 7	4/8/2019	JRF
+L1.L4/27	Schematic multi-line	PLC 8	4/8/2019	JRF
+L1.L4/28	Schematic multi-line	PLC 9	4/8/2019	JRF
+L1.L4/29	Schematic multi-line	PLC 10	5/7/2019	JRF
+L1.L4/30	Schematic multi-line	PLC 11	4/8/2019	JRF
+L1.L4/31	Schematic multi-line	PLC 12	4/8/2019	JRF
+L1.L4/32	Schematic multi-line	PLC 13	4/8/2019	JRF
+L1.L4/33	Schematic multi-line	PLC 14	5/7/2019	JRF
+L1.L4/34	Schematic multi-line	PLC 15	4/8/2019	JRF



Wood-Mizer®

Project Description: WM4500

Revision:	A1.00	Pg Desc: Table of contents
Mounting Location: +		Type: Table of contents
Prev. pg:	Page: A1	Next pg: A2
		Total Pgs: 78

Table of contents

WM_TableOfContents

Page	Page type	Page description	Date	Edited by
+L5.L7/35	Schematic multi-line	HMI 1	4/8/2019	JRF
+L9/36	Schematic multi-line	Pull Down Clamp Module	5/7/2019	JRF
+L9/37	Schematic multi-line	Pull Down Clamp 1	4/8/2019	JRF
+L9/38	Schematic multi-line	Pull Down Clamp 2	4/8/2019	JRF
+Docs/C1	Parts list	Parts list	5/7/2019	JRF
+Docs/C2	Parts list	Parts list	5/7/2019	JRF
+Docs/C3	Parts list	Parts list	5/7/2019	JRF
+Docs/D1	Terminal line-up diagram	Terminal line-up diagram	4/8/2019	JRF
+Docs/D2	Terminal line-up diagram	Terminal line-up diagram	5/7/2019	JRF
+Docs/D3	Terminal line-up diagram	Terminal line-up diagram	4/8/2019	JRF
+Docs/D4	Terminal line-up diagram	Terminal line-up diagram	4/8/2019	JRF
+Docs/D5	Terminal line-up diagram	Terminal line-up diagram	5/7/2019	JRF
+Docs/D6	Terminal line-up diagram	Terminal line-up diagram	4/8/2019	JRF
+Docs/D7	Terminal line-up diagram	Terminal line-up diagram	4/8/2019	JRF
+Docs/D8	Terminal line-up diagram	Terminal line-up diagram	4/8/2019	JRF
+Docs/D9	Terminal line-up diagram	Terminal line-up diagram	4/8/2019	JRF
+Docs/E1	Cable overview	Cable overview	4/8/2019	JRF
+Docs/E2	Cable overview	Cable overview	5/7/2019	JRF
+Docs/E3	Cable overview	Cable overview	5/7/2019	JRF
+Docs/F1	Panel layout	Main Control Layout	4/8/2019	JRF
+Docs/F2	Panel layout	Main Control Disconnect Layout	4/8/2019	JRF
+Docs/F3	Panel layout	Main Control High Voltage Layout	4/8/2019	JRF
+Docs/F4	Panel layout	Main Control Low Voltage Layout	4/8/2019	JRF
+Docs/F5	Panel layout	Operator Ctl Layout	4/8/2019	JRF
+Docs/F6	Panel layout	Operator Ctl Solenoid Layout	4/8/2019	JRF
+Docs/F7	Panel layout	Operator Ctl Junction Layout	4/8/2019	JRF
+Docs/F8	Panel layout	Operator Ctl HMI Layout	4/8/2019	JRF
+Docs/F9	Panel layout	Operator Ctl Bed Ex Layout	4/8/2019	JRF
+Docs/F10	Panel layout	Operator Ctl Side Supports Layout	4/8/2019	JRF
+Docs/F11	Panel layout	Hydraulic Control Layout	4/8/2019	JRF
+Docs/F12	Panel layout	Hydraulic Control Junction Layout	4/8/2019	JRF
+Docs/F13	Panel layout	Head Control Layout Pg1	4/8/2019	JRF
+Docs/F14	Panel layout	Head Control Layout Pg2	4/8/2019	JRF
+Docs/F15	Panel layout	Head Control Junction Layout	4/8/2019	JRF
+Mfg_Docs/G1	Parts list	Parts list Manufacturer	5/7/2019	JRF
+Mfg_Docs/G2	Parts list	Parts list Manufacturer	5/7/2019	JRF
+Mfg_Docs/G3	Parts list	Parts list Manufacturer	5/7/2019	JRF
+Mfg_Docs/H1	Cable overview	Cable Overview Manufacturer	5/7/2019	JRF



Wood-Mizer®

Project Description: WM4500

Revision:	A1.00	Pg Desc:	Table of contents
Mounting Location:	+	Type:	Table of contents
Prev. pg:	A1	Page:	A2
Next pg:	A3	Total Pgs:	78

Revision History

Date	Revision	Revision Record	Drawn By	Checked By
9/23/13	A2.00	Changed Proportional Controller (068163 to 068227) and Proportional Controller Cable (069951 to 068229), Old Controller Obsolete.	JRF	SDC
11/18/13	A3.00	Added a Dump Valve to the Hydraulic Power Unit and made the Hydraulic Pump Motor run continuously.	JRF	SDC
2/5/14	A4.00	Added Controls for 12' Hydraulic Bed Extension.	JRF	SDC
3/18/14	A4.01	Added Controls For Side Supports on Loading Side of Mill.	JRF	SDC
4/17/14	A4.02	Error Correction on Analog Output Card.	JRF	SDC
9/4/14	A5.00	Changed Manufacturer of G2 Power Supply.	JRF	SDC
5/19/15	A6.00	Increased Size of G2 Power Supply.	JRF	SDC
5/25/16	A7.00	Improved Auxiliary E-Stop Circuit Connections.	JRF	SDC
8/1/16	A8.00	New Feed Motor.	JRF	SDC
6/27/17	B1.00	New Feed Drive and HMI.	JRF	SDC
9/25/17	B1.01	Feed Encoder parameter change for reverse rotation.	JRF	SDC
11/29/17	B1.02	Added PE wire to control terminals on Feed Drive.	JRF	SDC
4/5/18	B2.00	Replaced M258 PLC with M251	JRF	SDC
5/2/18	B3.00	Changed Hydraulic Pump Motor	JRF	SDC

		Wood-Mizer®	
Project Description: WM4500			
Revision:	A1.00	Pg Desc: Revision History	
Mounting Location: +		Type: Overview	
Prev. pg:	A3	Page:	B1
Next pg:	+L1.L3/1	Total Pgs:	78

Wood-Mizer®

Voltage	480VAC +4/-10%
Phase	3Ph
Frequency	60 Hz
FLA Machine	94.1A
FLA Largest Load	38A
Wiring Diagram	
SCCR	5kA

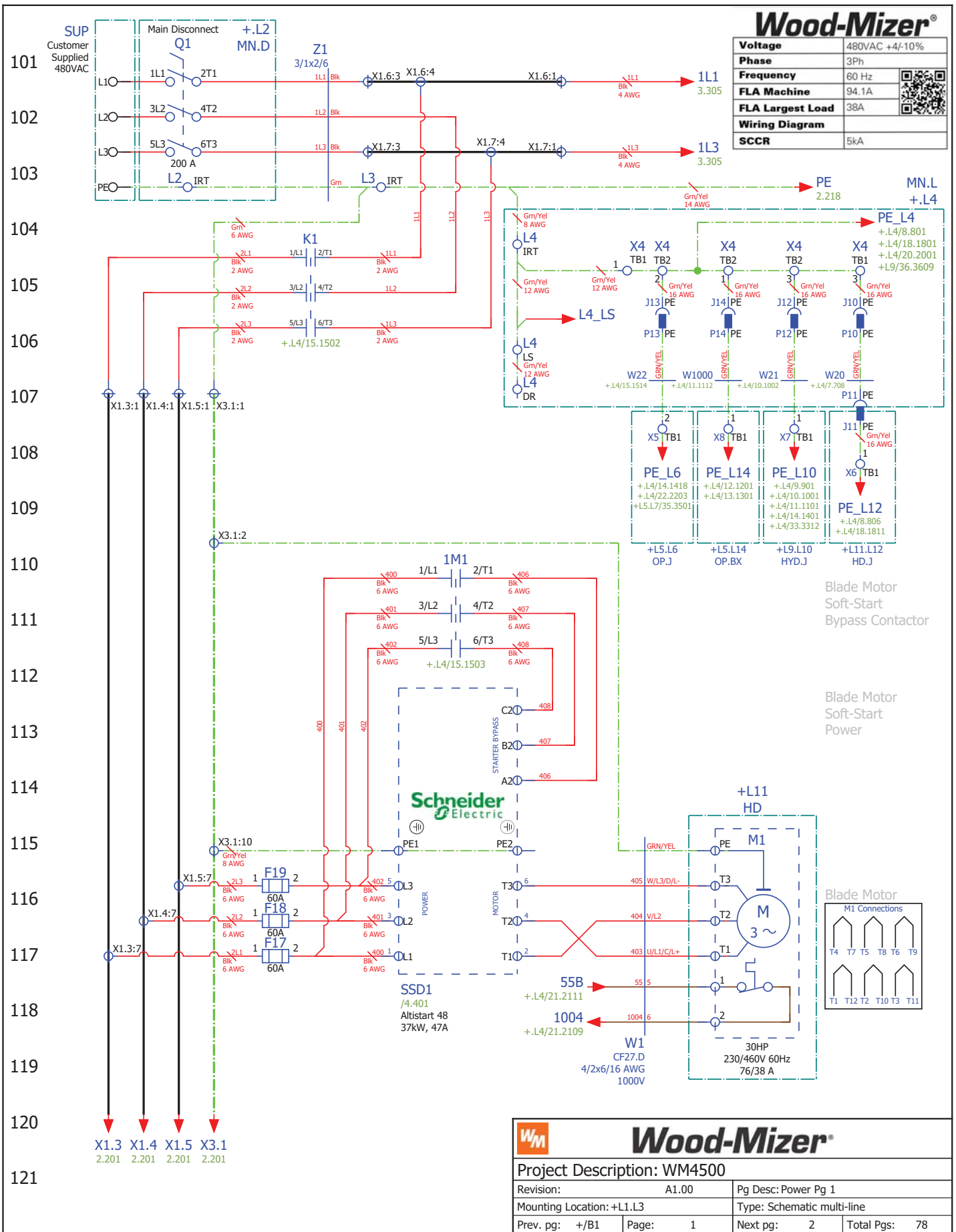

Blade Motor
Soft-Start
Bypass Contactor

Blade Motor
Soft-Start
Power

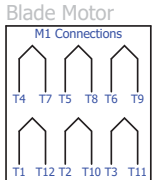

Wood-Mizer®

Project Description: WM4500

Revision:	A1.00	Pg Desc: Power Pg 1
Mounting Location:	+L1.L3	Type: Schematic multi-line
Prev. pg:	+/B1	Page: 1
		Next pg: 2
		Total Pgs: 78

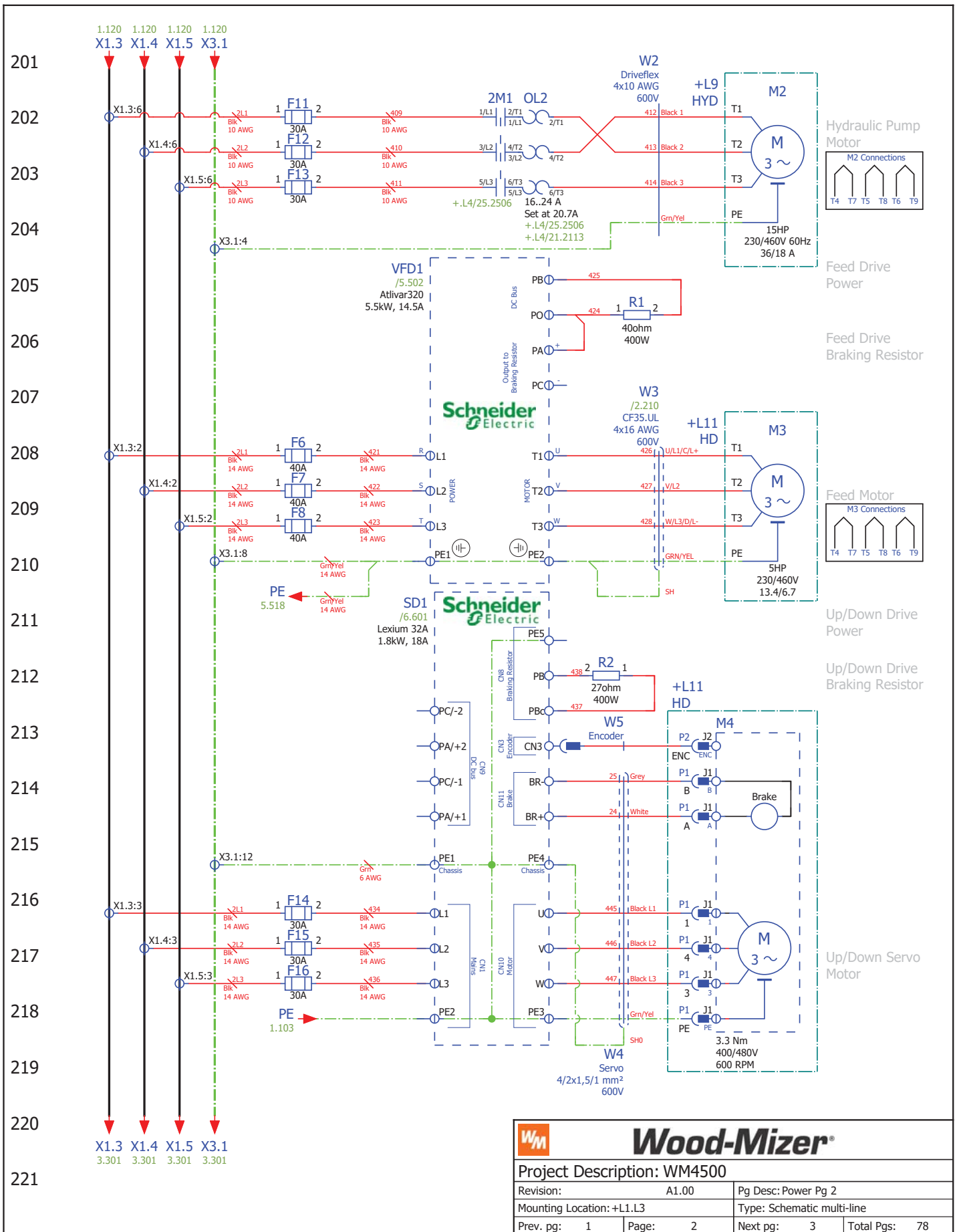

Wood-Mizer®			
Project Description: WM4500			
Revision:	A1.00	Pg Desc: Power Pg 2	
Mounting Location:	+L1.L3	Type: Schematic multi-line	
Prev. pg:	1	Page:	2
		Next pg:	3
		Total Pgs:	78

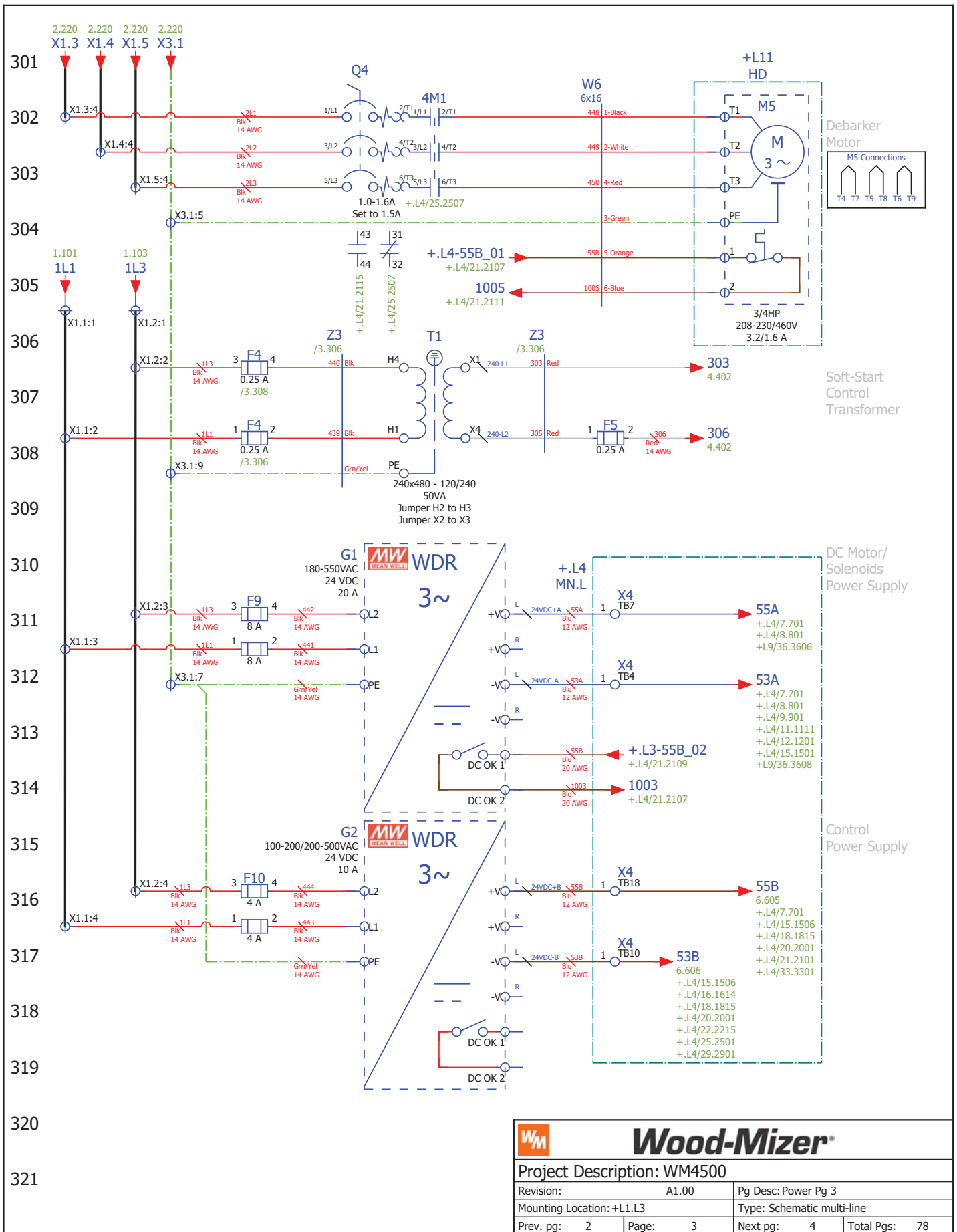

Wood-Mizer®			
Project Description: WM4500			
Revision:	A1.00	Pg Desc: Power Pg 3	
Mounting Location:	+L1.L3	Type: Schematic multi-line	
Prev. pg:	2	Page:	3
		Next pg:	4
		Total Pgs:	78

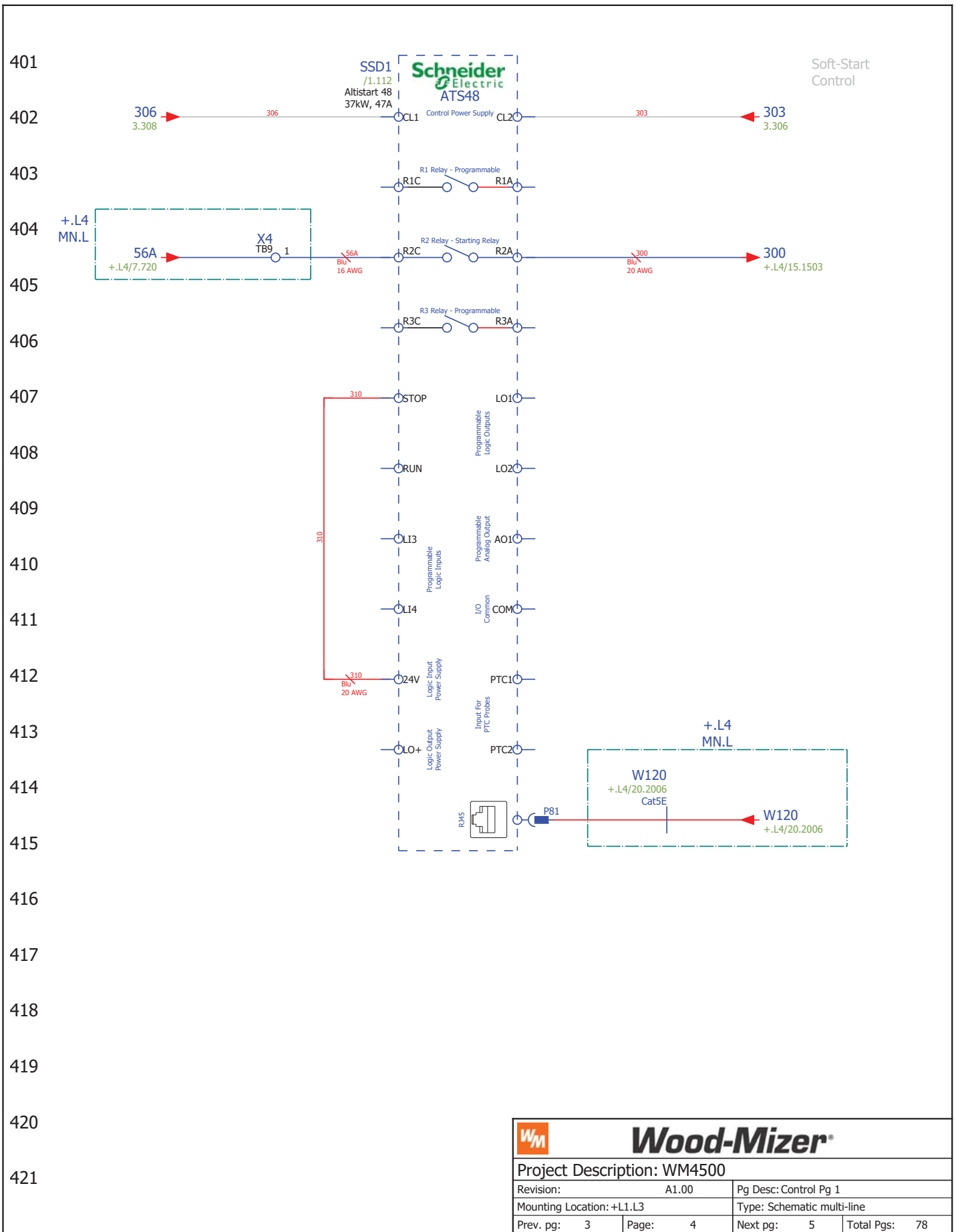

501
502
503
504
505
506
507
508
509
510
511
512
513
514
515
516
517
518
519
520
521

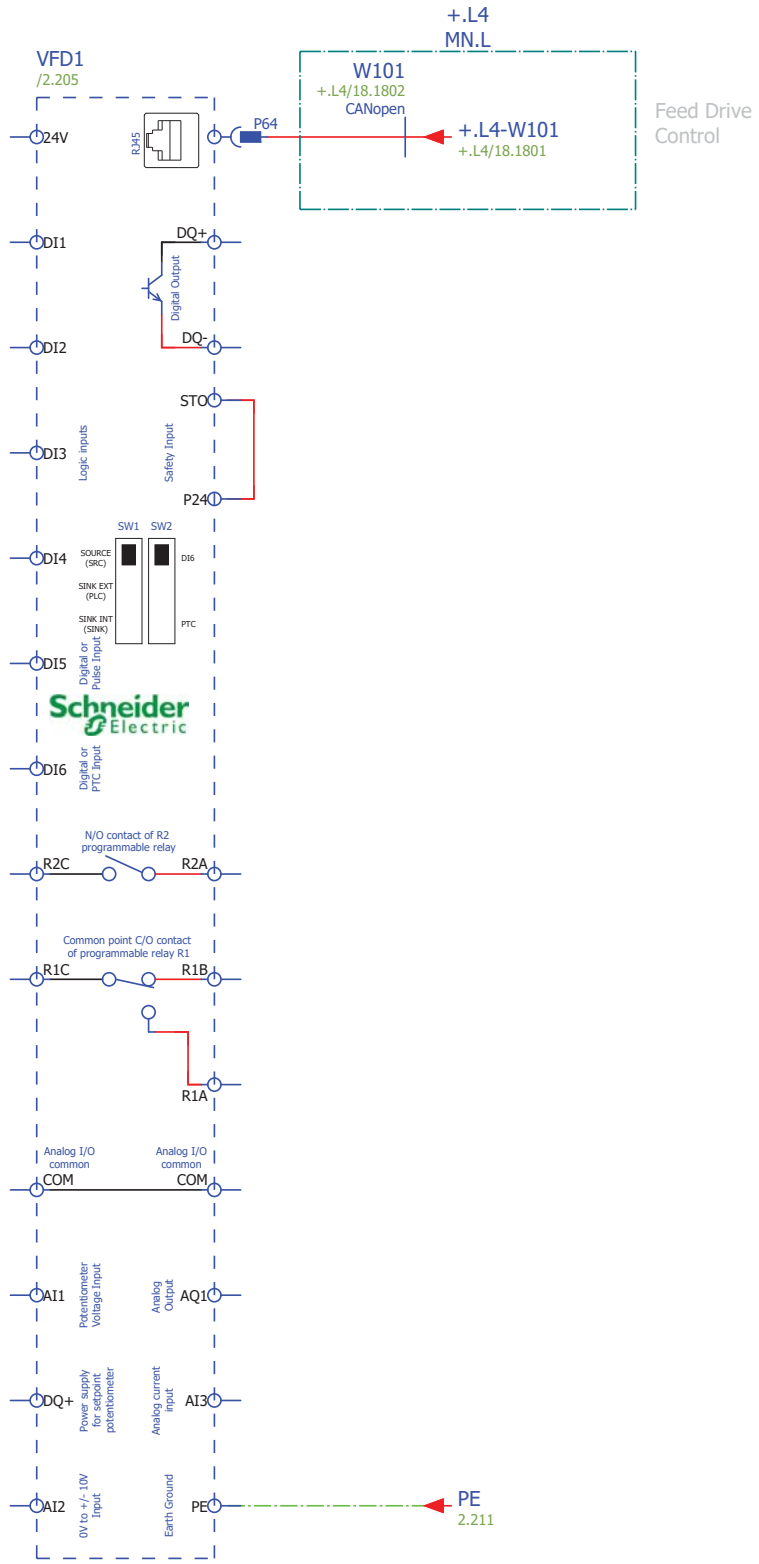

		Wood-Mizer®	
Project Description: WM4500			
Revision:	A1.00	Pg Desc: Control Pg 2	
Mounting Location:	+L1.L3	Type: Schematic multi-line	
Prev. pg:	4	Page:	5
		Next pg:	6
		Total Pgs:	78

601
602
603
604
605
606
607
608
609
610
611
612
613
614
615
616
617
618
619
620
621

Up/Down Drive Control

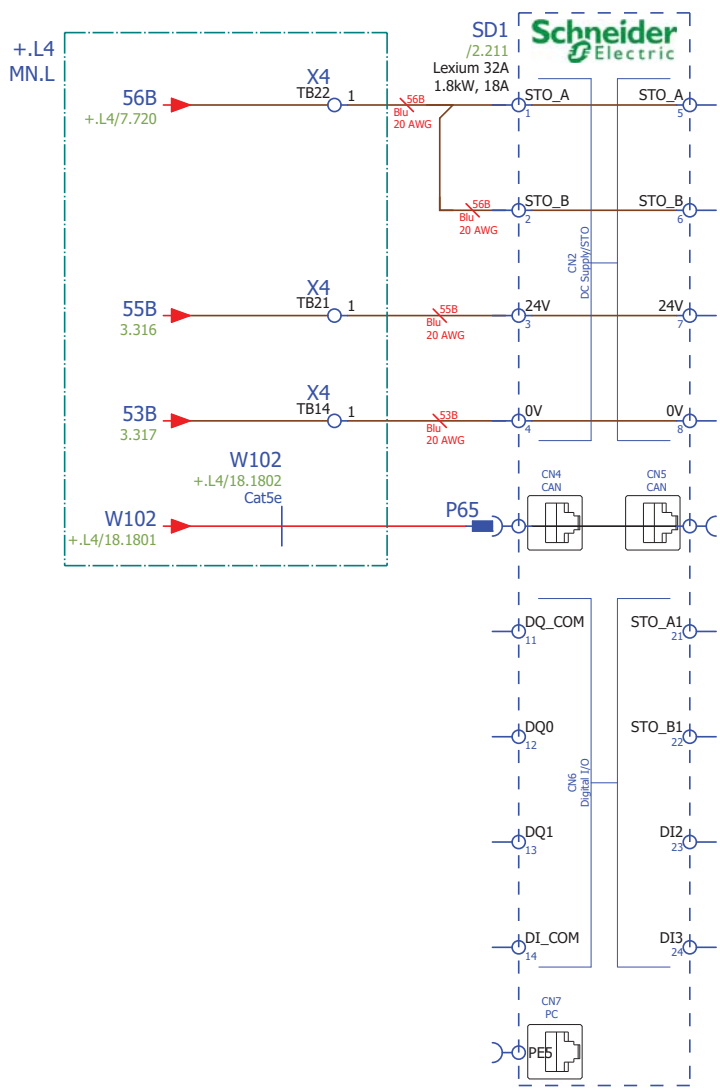

		Wood-Mizer®	
Project Description: WM4500			
Revision:	A1.00	Pg Desc: Control Pg 3	
Mounting Location:	+L1.L3	Type: Schematic multi-line	
Prev. pg:	5	Page:	6
Next pg:	+L4/7	Total Pgs:	78

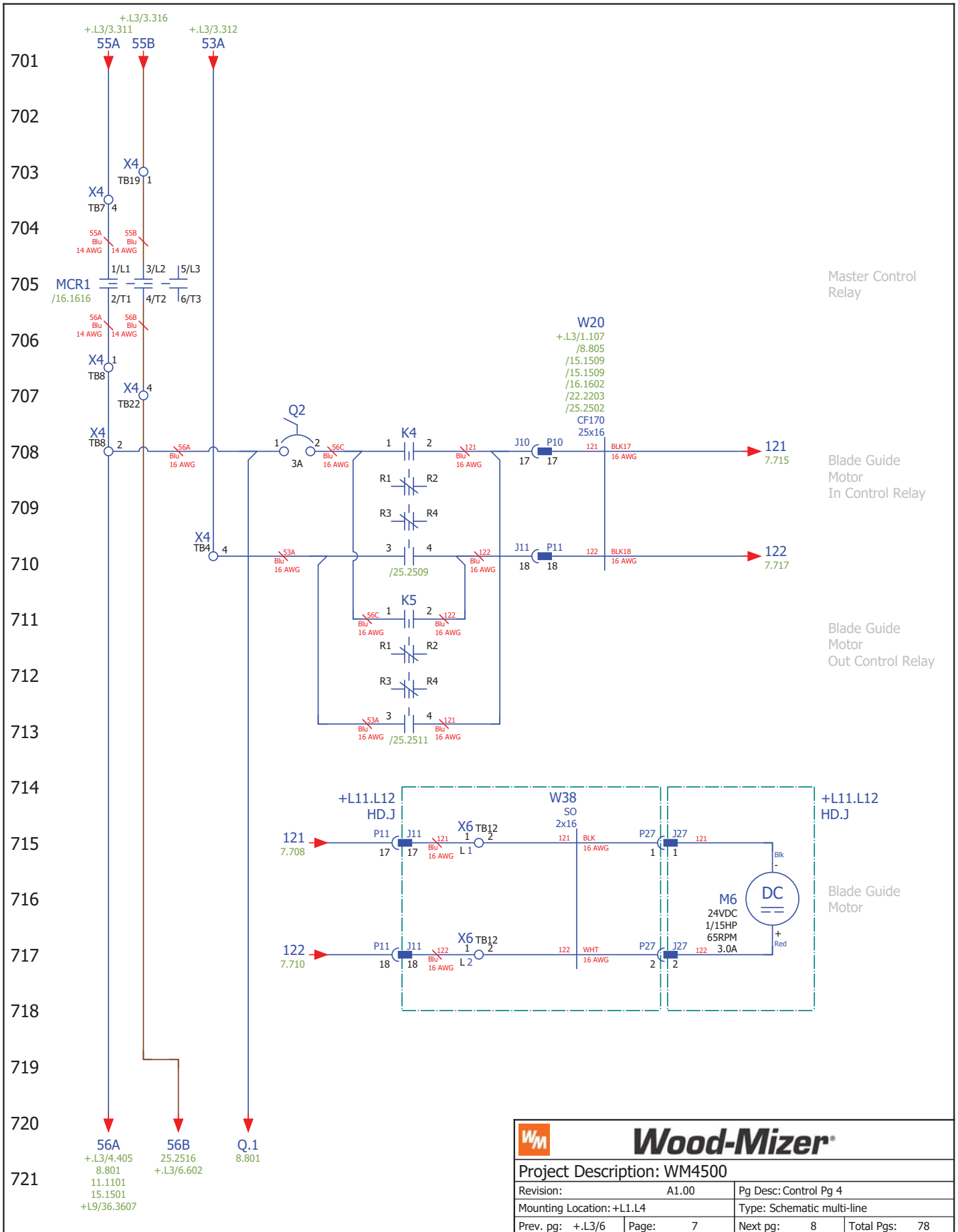

Wood-Mizer®			
Project Description: WM4500			
Revision:	A1.00	Pg Desc: Control Pg 4	
Mounting Location:	+L1.L4		Type: Schematic multi-line
Prev. pg:	+L3/6	Page:	7
Next pg:	8	Total Pgs:	78

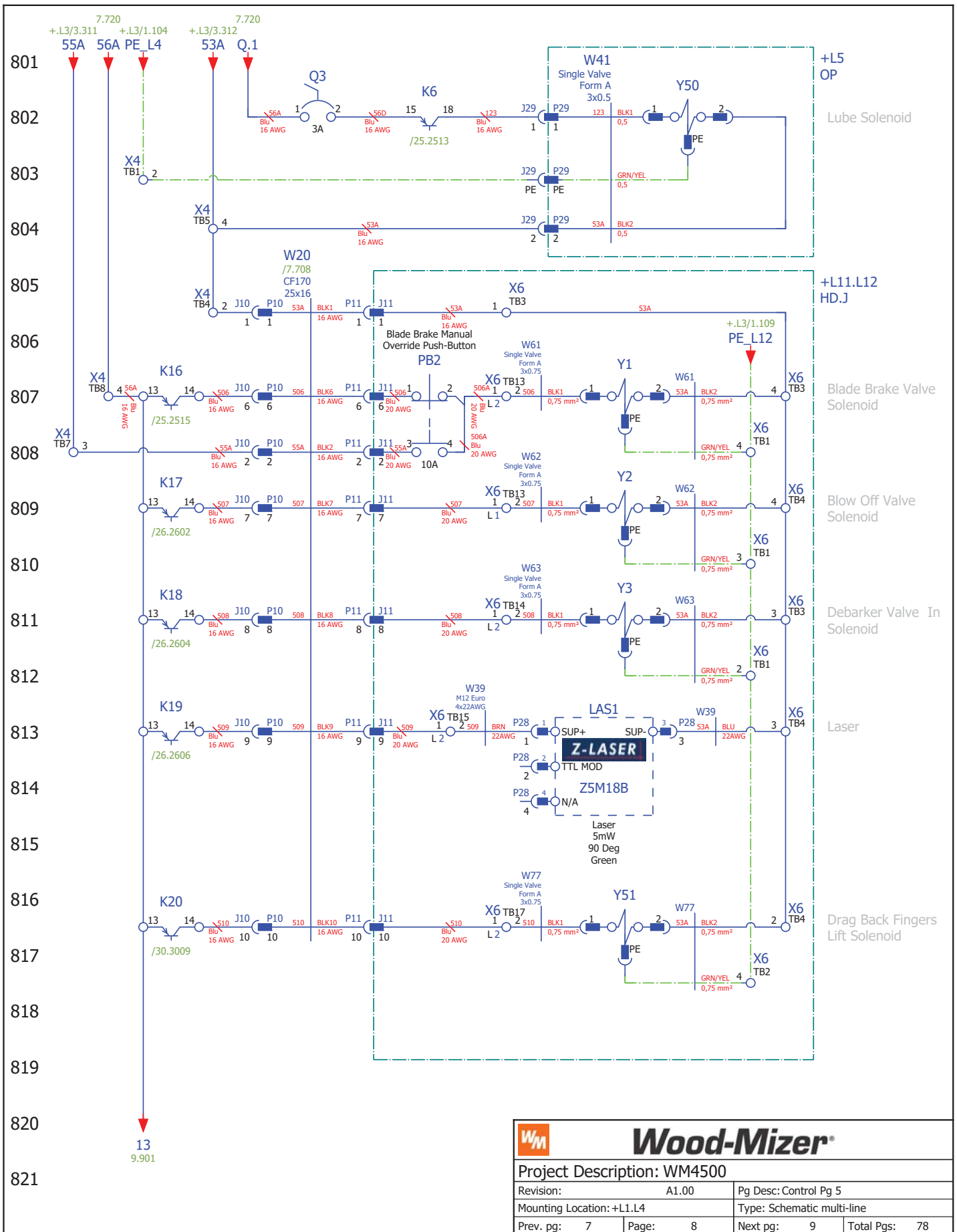

 Wood-Mizer®			
Project Description: WM4500			
Revision:	A1.00	Pg Desc: Control Pg 5	
Mounting Location:	+L1.L4	Type: Schematic multi-line	
Prev. pg:	7	Page:	8
		Next pg:	9
		Total Pgs:	78

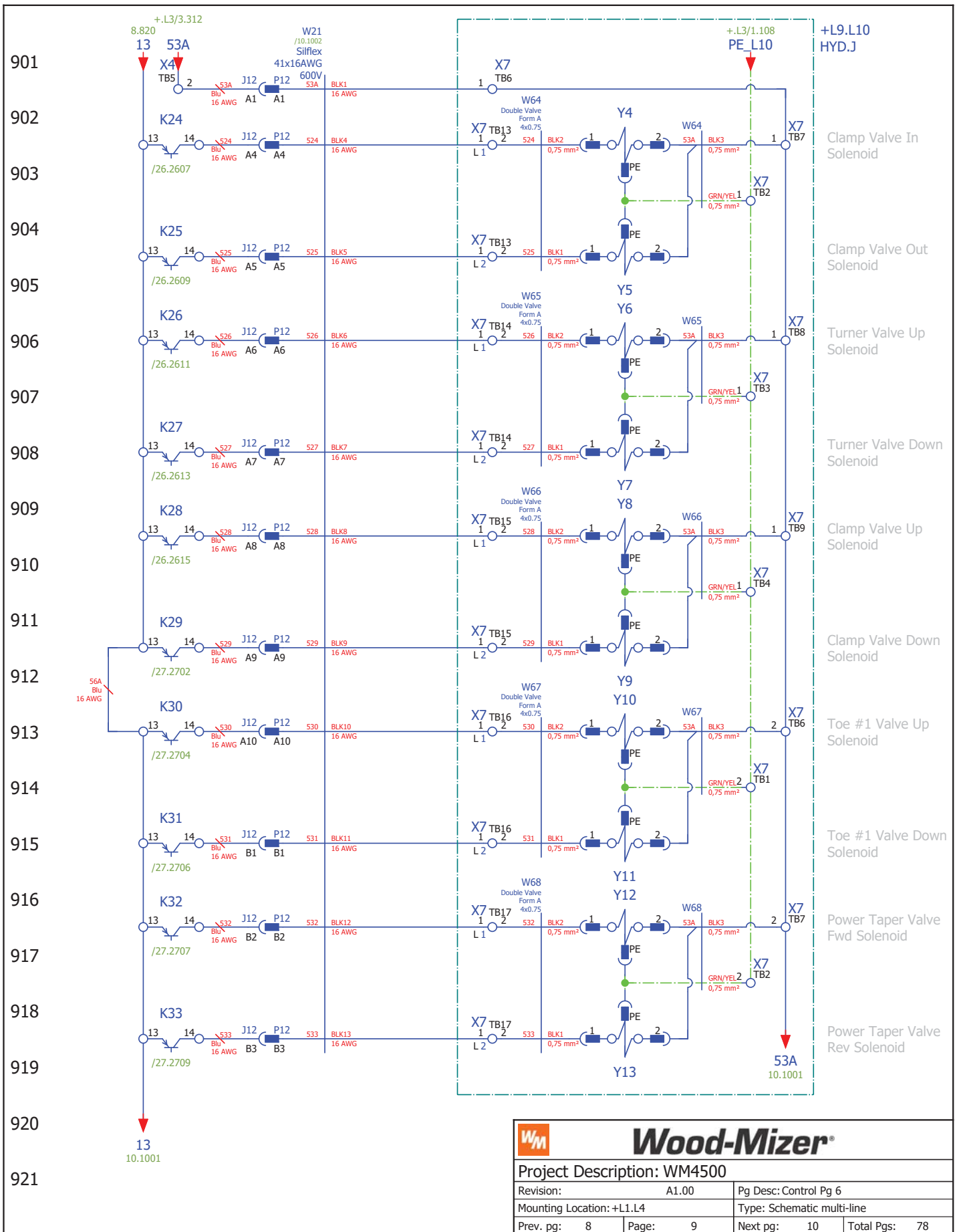

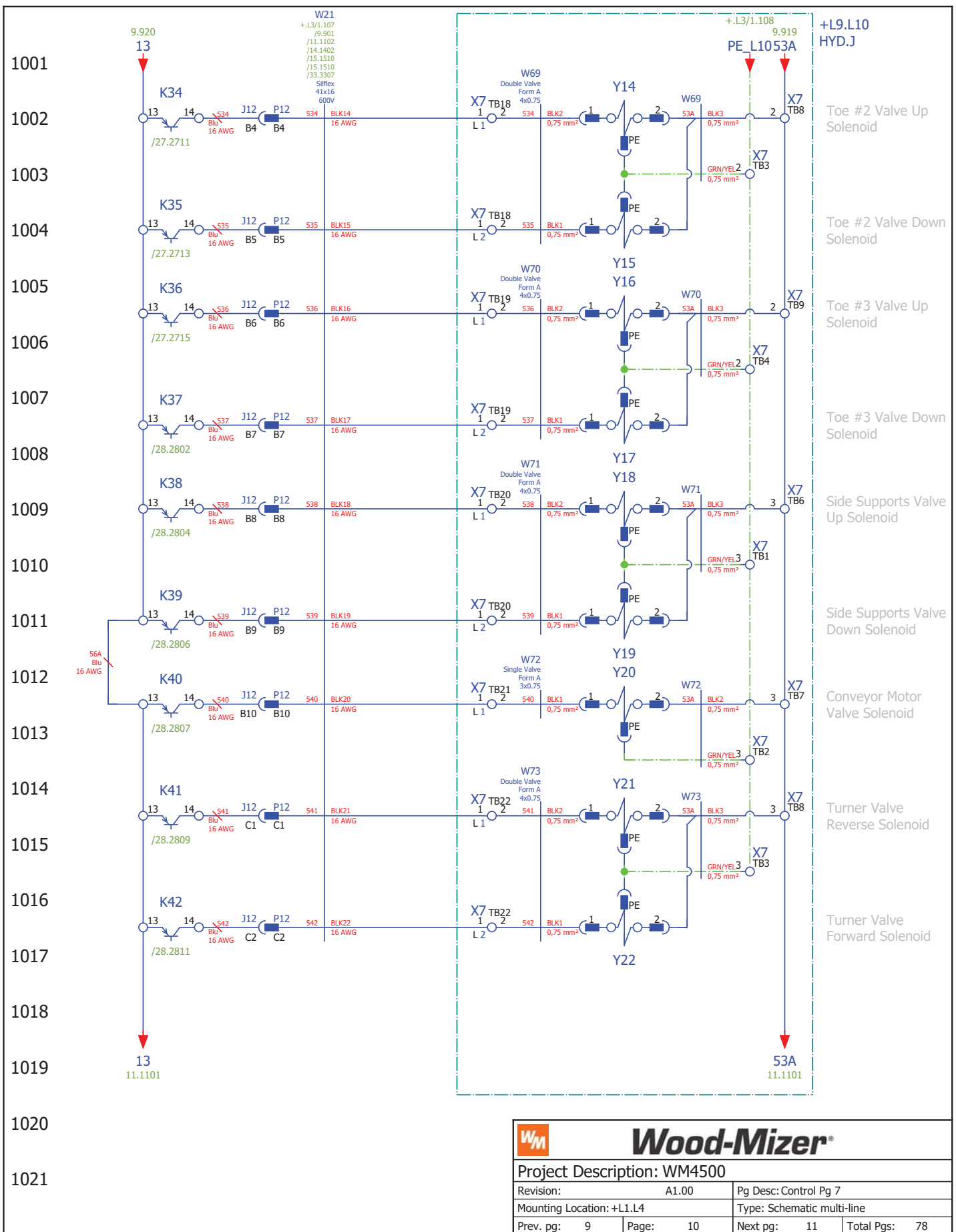

Wood-Mizer®	
Project Description: WM4500	
Revision: A1.00	Pg Desc: Control Pg 7
Mounting Location: +L1.L4	Type: Schematic multi-line
Prev. pg: 9	Page: 10
Next pg: 11	Total Pgs: 78

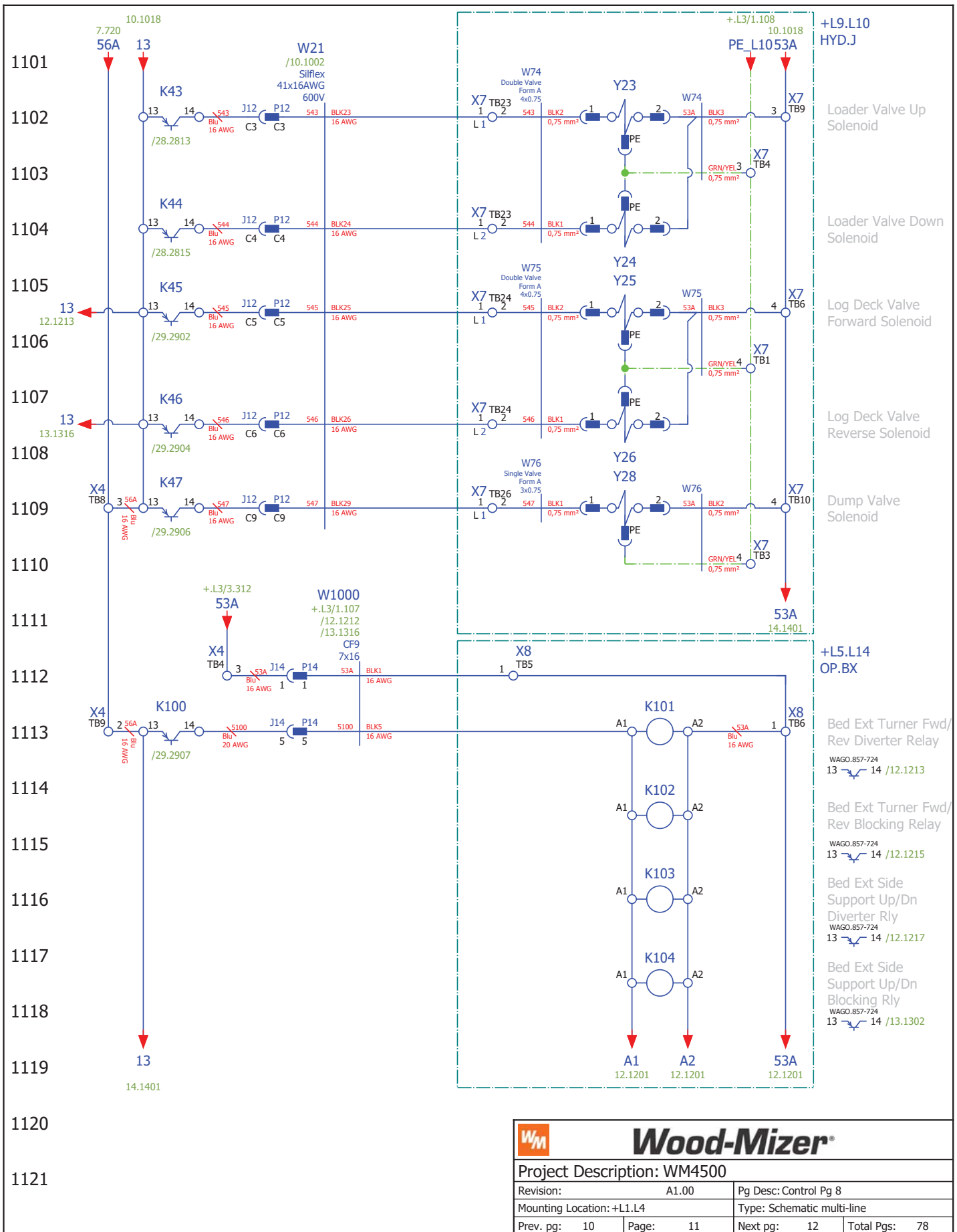

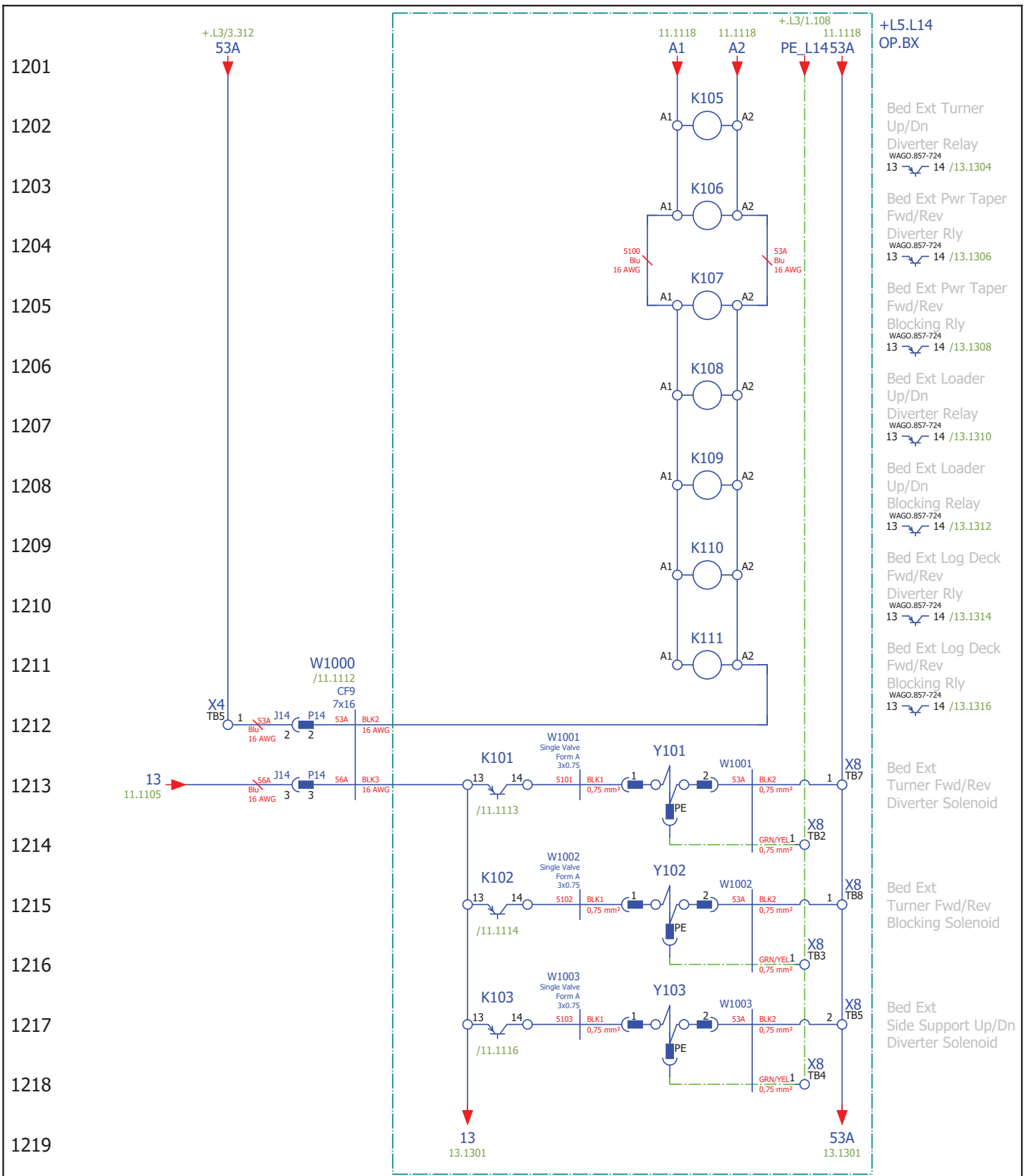

- Bed Ext Turner Up/Dn Diverter Relay WAGO.857-724 13 14 /13.1304
- Bed Ext Pwr Taper Fwd/Rev Diverter Rly WAGO.857-724 13 14 /13.1306
- Bed Ext Pwr Taper Fwd/Rev Blocking Rly WAGO.857-724 13 14 /13.1308
- Bed Ext Loader Up/Dn Diverter Relay WAGO.857-724 13 14 /13.1310
- Bed Ext Loader Up/Dn Blocking Relay WAGO.857-724 13 14 /13.1312
- Bed Ext Log Deck Fwd/Rev Diverter Rly WAGO.857-724 13 14 /13.1314
- Bed Ext Log Deck Fwd/Rev Blocking Rly WAGO.857-724 13 14 /13.1316

- Bed Ext Turner Fwd/Rev Diverter Solenoid
- Bed Ext Turner Fwd/Rev Blocking Solenoid
- Bed Ext Side Support Up/Dn Diverter Solenoid

Wood-Mizer®	
Project Description: WM4500	
Revision: A1.00	Pg Desc: Control Pg 9
Mounting Location: +L1.L4	Type: Schematic multi-line
Prev. pg: 11	Page: 12
Next pg: 13	Total Pgs: 78

1301
1302
1303
1304
1305
1306
1307
1308
1309
1310
1311
1312
1313
1314
1315
1316
1317
1318
1319
1320
1321

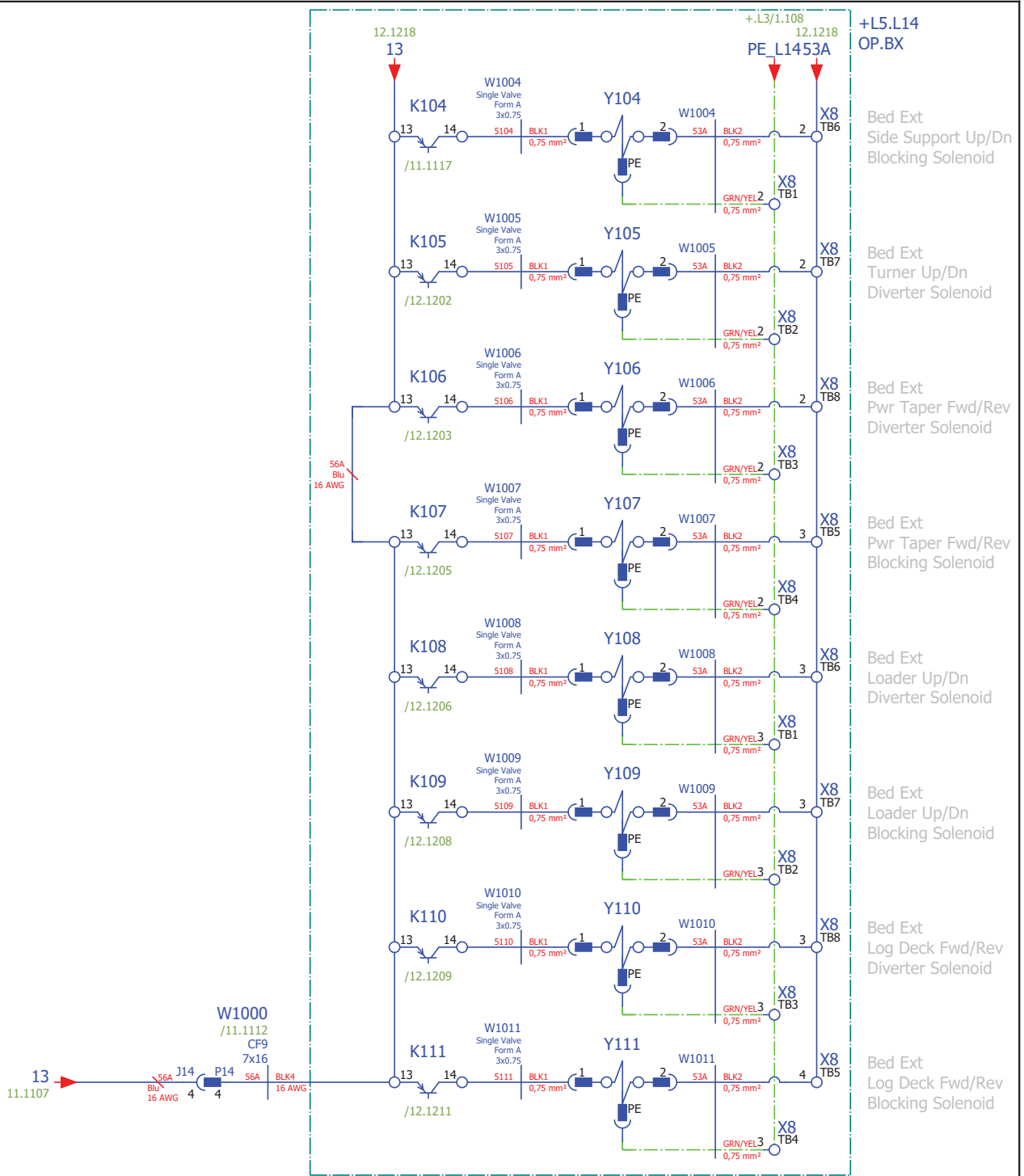

+L5.L14
OP.BX

Bed Ext
Side Support Up/Dn
Blocking Solenoid

Bed Ext
Turner Up/Dn
Diverter Solenoid

Bed Ext
Pwr Taper Fwd/Rev
Diverter Solenoid

Bed Ext
Pwr Taper Fwd/Rev
Blocking Solenoid

Bed Ext
Loader Up/Dn
Diverter Solenoid

Bed Ext
Loader Up/Dn
Blocking Solenoid

Bed Ext
Log Deck Fwd/Rev
Diverter Solenoid

Bed Ext
Log Deck Fwd/Rev
Blocking Solenoid

Wood-Mizer®	
Project Description: WM4500	
Revision: A1.00	Pg Desc: Control Pg 10
Mounting Location: +L1.L4	Type: Schematic multi-line
Prev. pg: 12	Page: 13
Next pg: 14	Total Pgs: 78

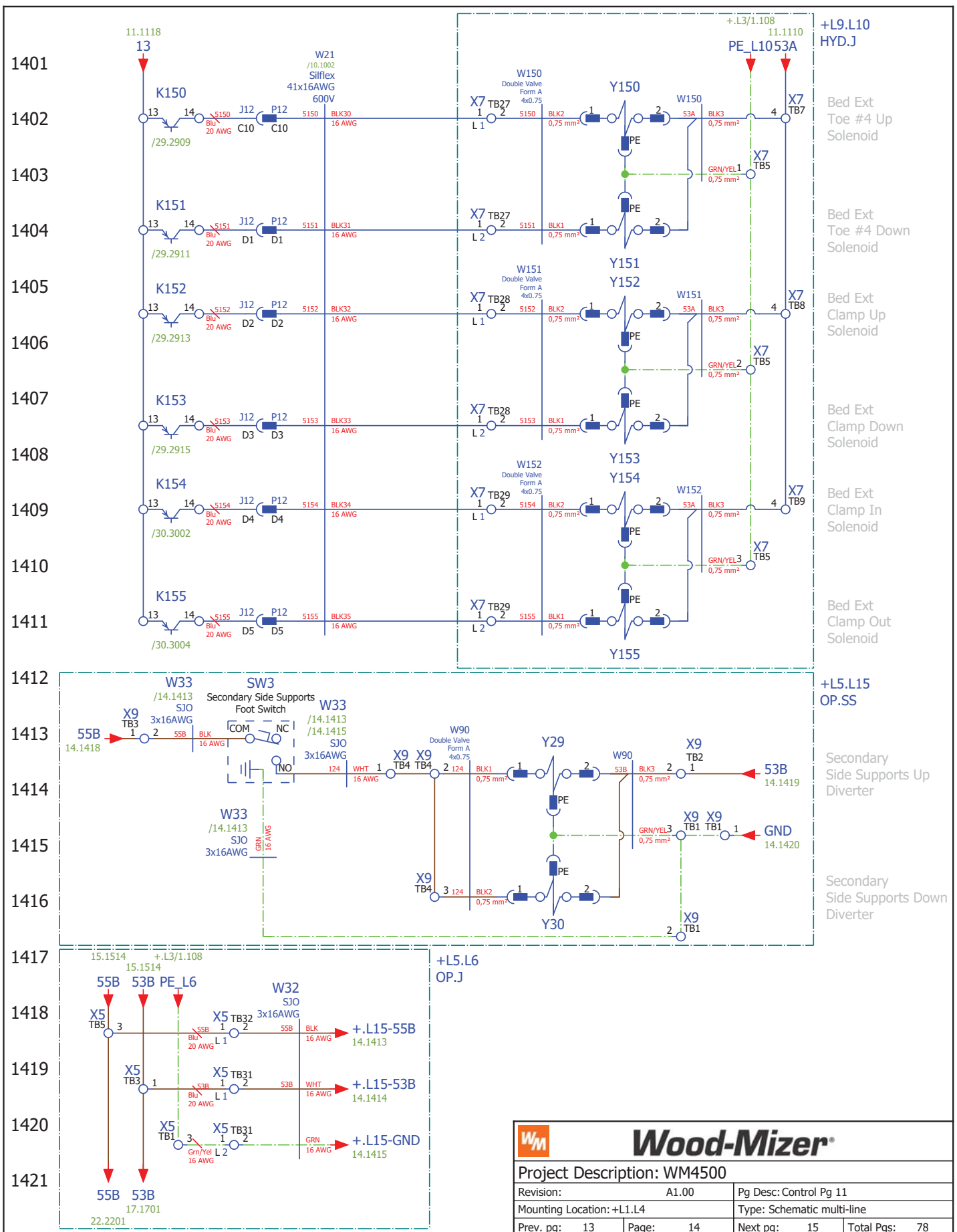

Wood-Mizer®			
Project Description: WM4500			
Revision:	A1.00	Pg Desc: Control Pg 11	
Mounting Location:	+L1.L4	Type: Schematic multi-line	
Prev. pg:	13	Page:	14
		Next pg:	15
		Total Pgs:	78

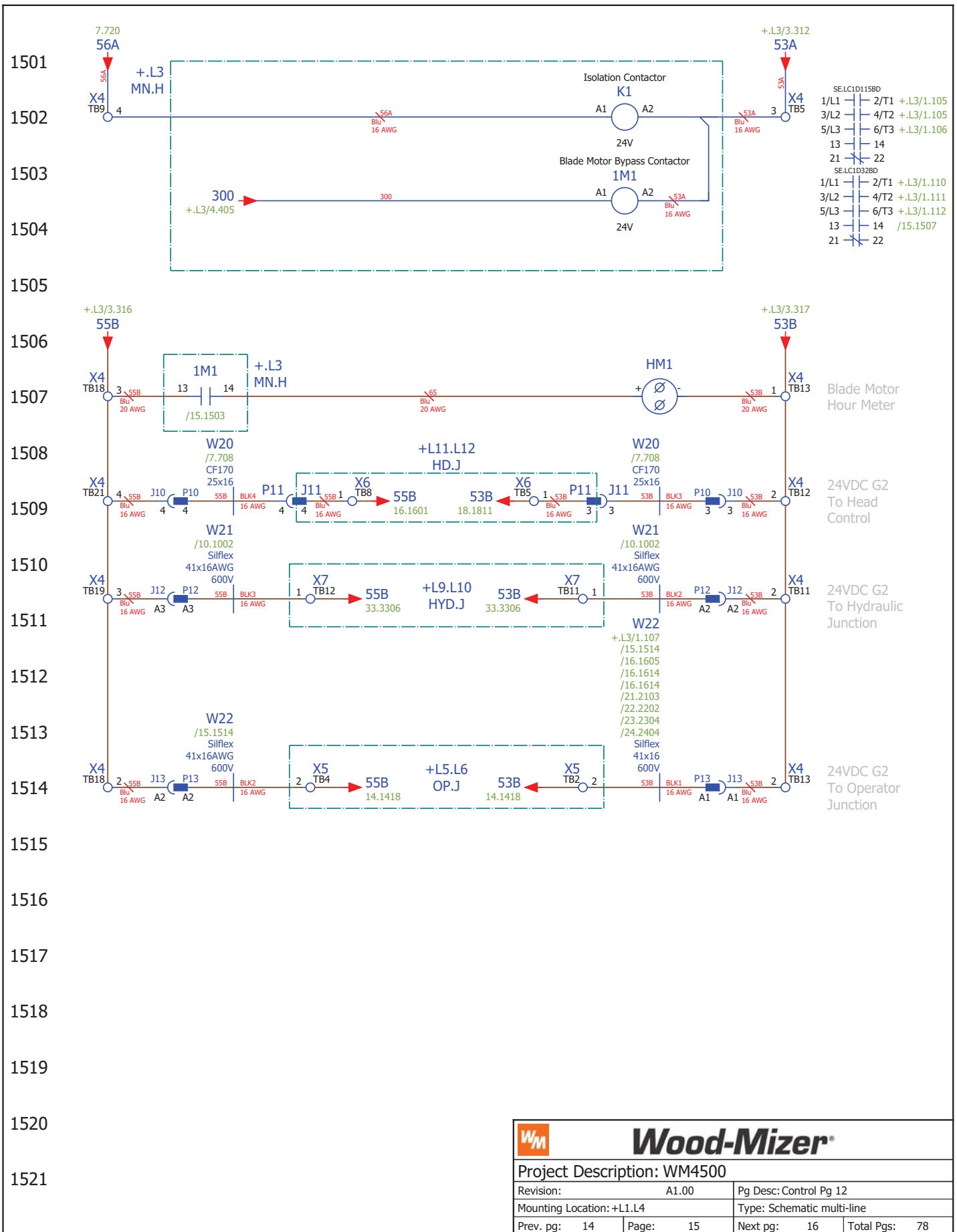

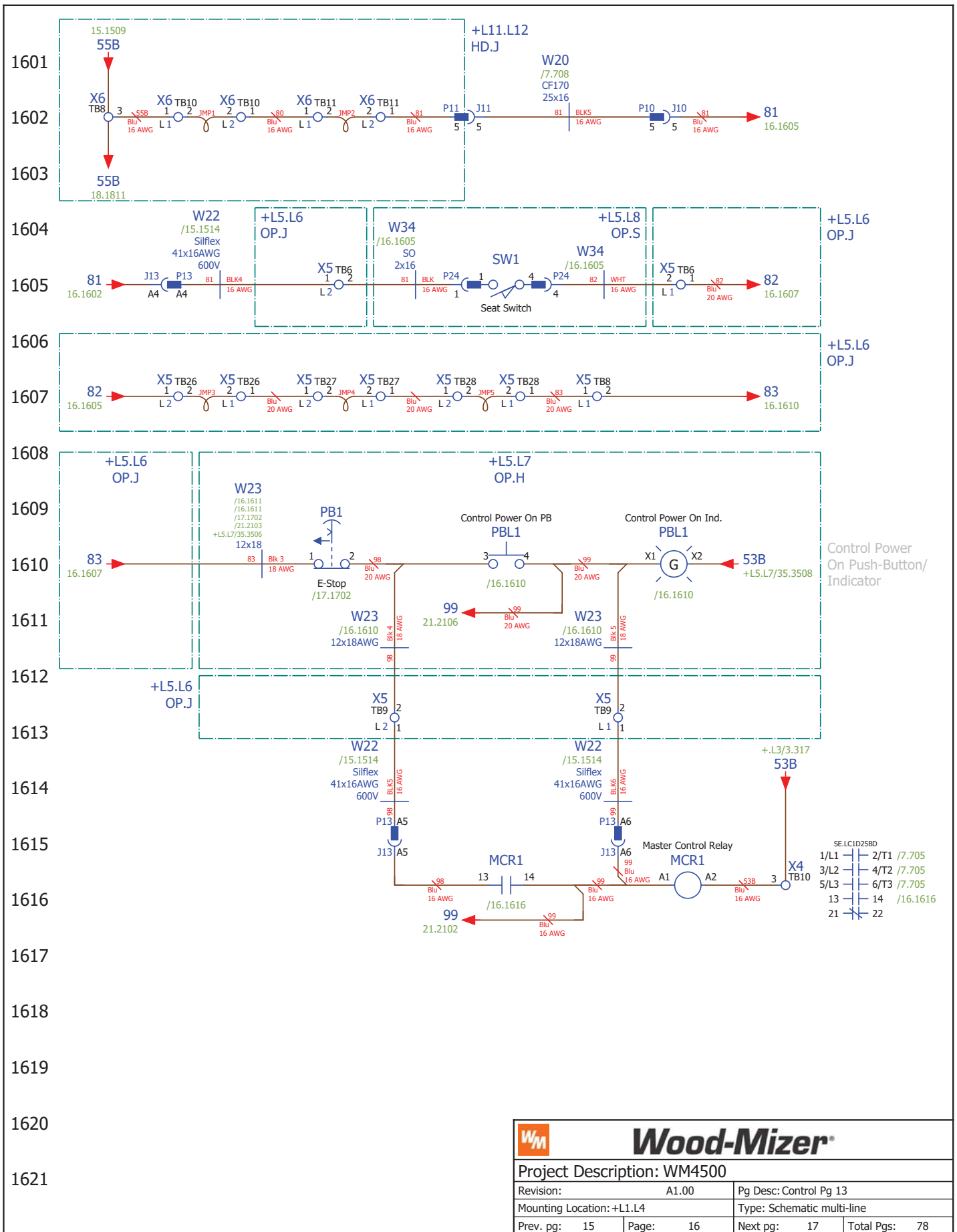

1701
1702
1703
1704
1705
1706
1707
1708
1709
1710
1711
1712
1713
1714
1715
1716
1717
1718
1719
1720
1721

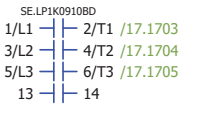
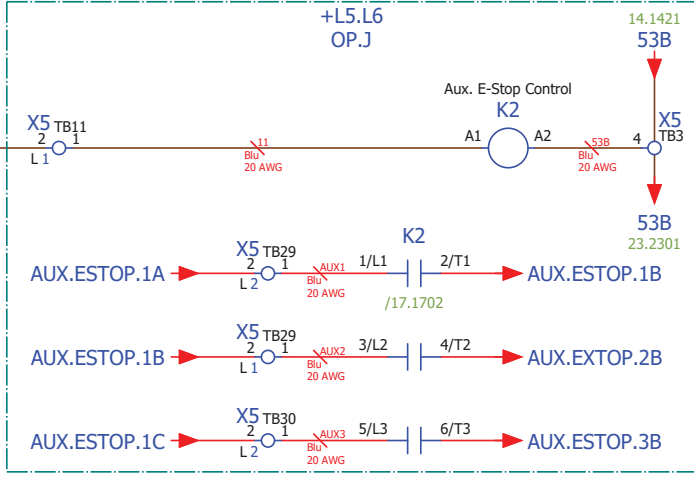
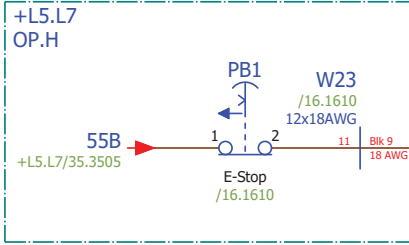

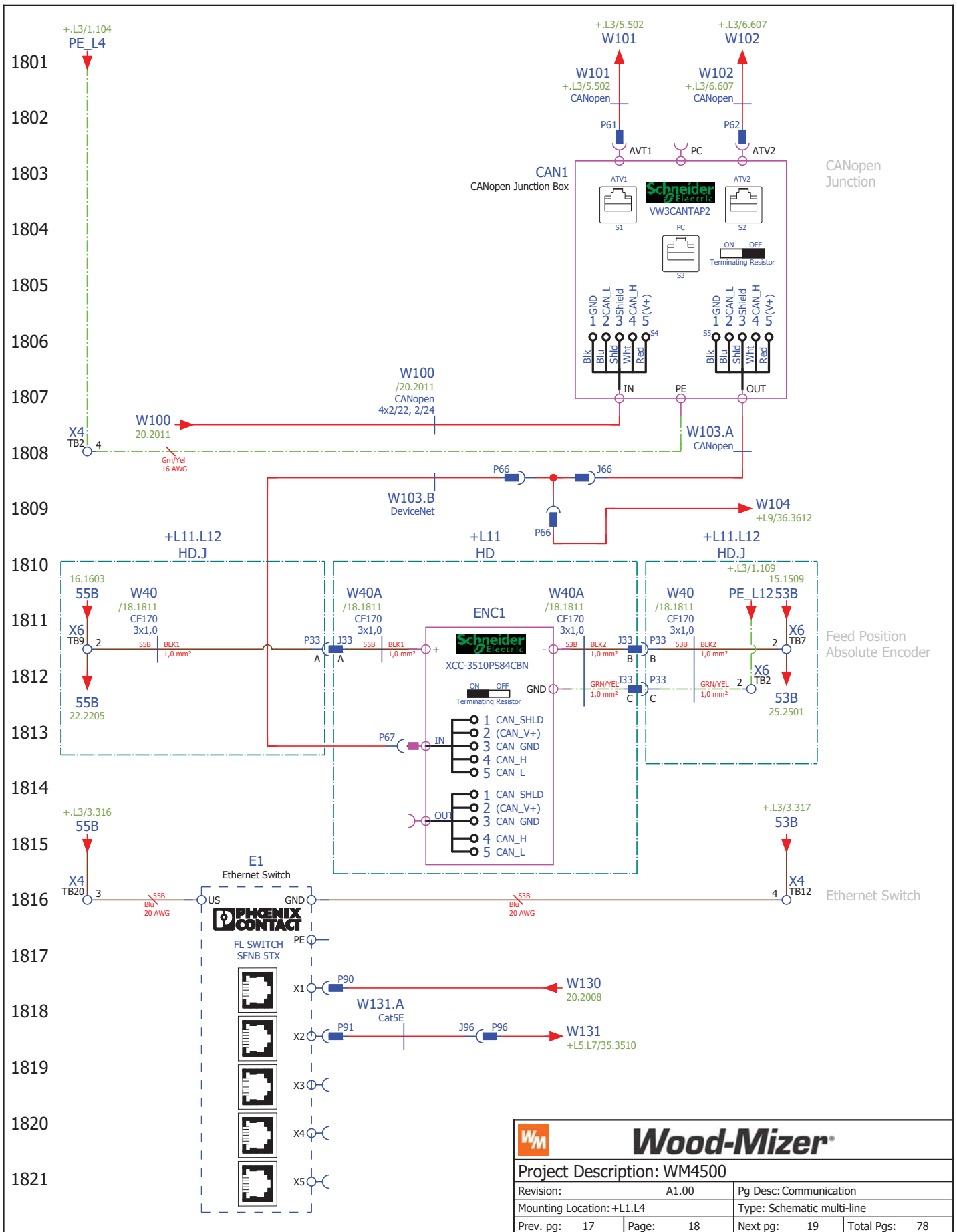

Auxiliary Equipment E-Stop Control 1
Auxiliary Equipment E-Stop Control 2
Auxiliary Equipment E-Stop Control 3

		Wood-Mizer®	
Project Description: WM4500			
Revision:	A1.00	Pg Desc: Control Pg 14	
Mounting Location:	+L1.L4	Type: Schematic multi-line	
Prev. pg:	16	Page:	17
Next pg:	18	Total Pgs:	78

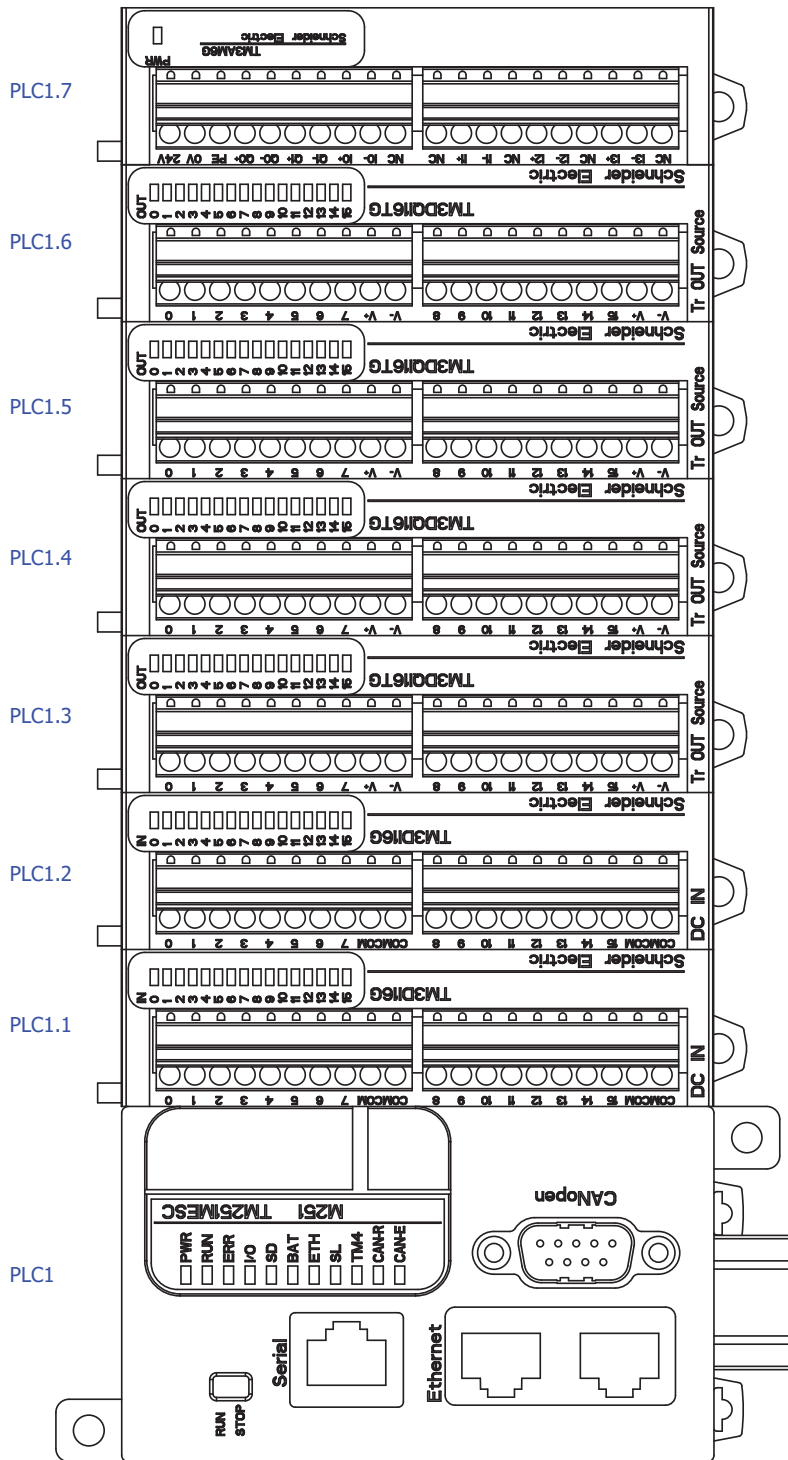

Wood-Mizer®			
Project Description: WM4500			
Revision:	A1.00	Pg Desc: Communication	
Mounting Location:	+L1.L4	Type: Schematic multi-line	
Prev. pg:	17	Page:	18
		Next pg:	19
		Total Pgs:	78



 Wood-Mizer®	
Project Description: WM4500	
Revision: A1.00	Pg Desc: PLC Diagram
Mounting Location: +L1.L4	Type: Panel layout
Prev. pg: 18	Page: 19
Next pg: 20	Total Pgs: 78

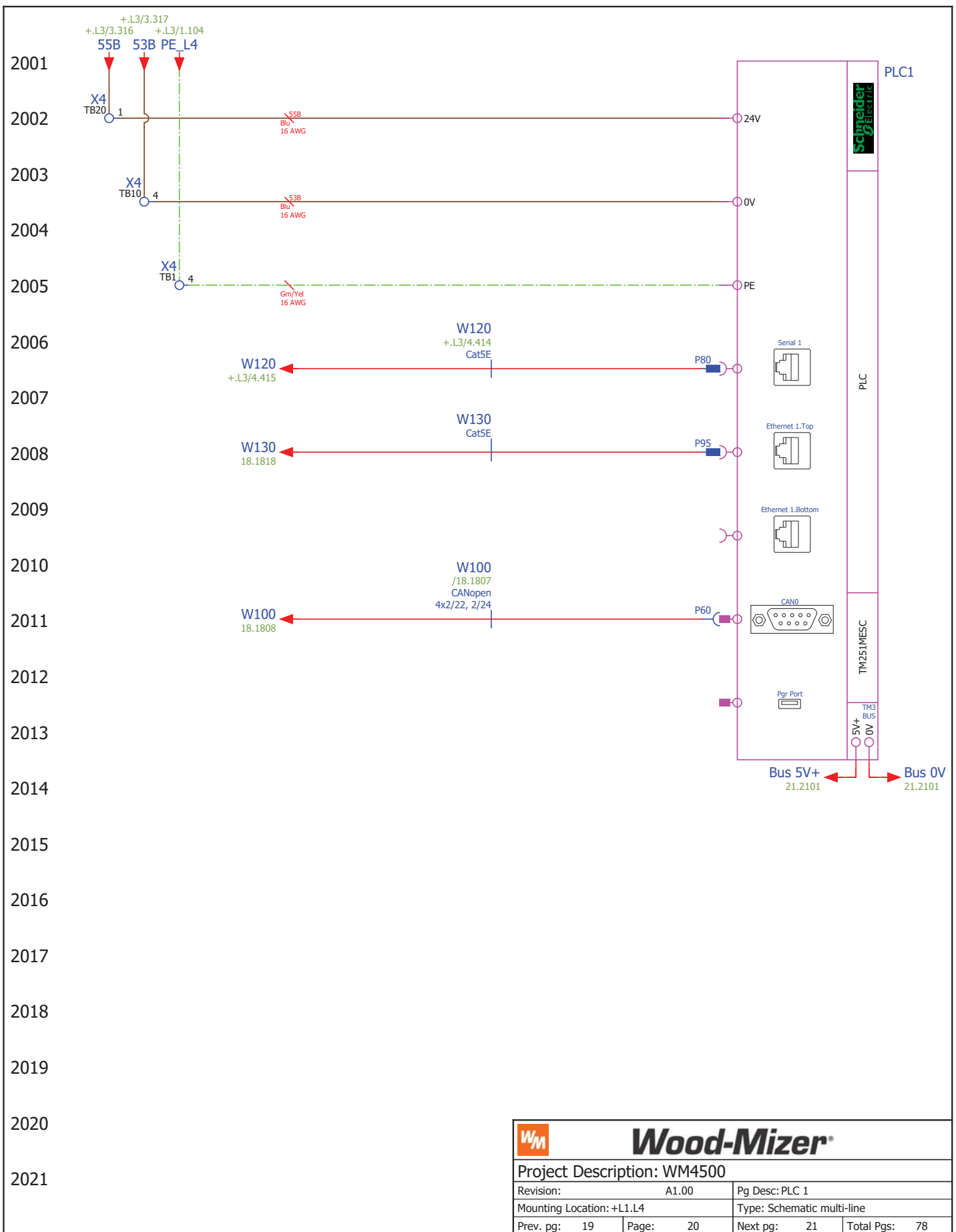

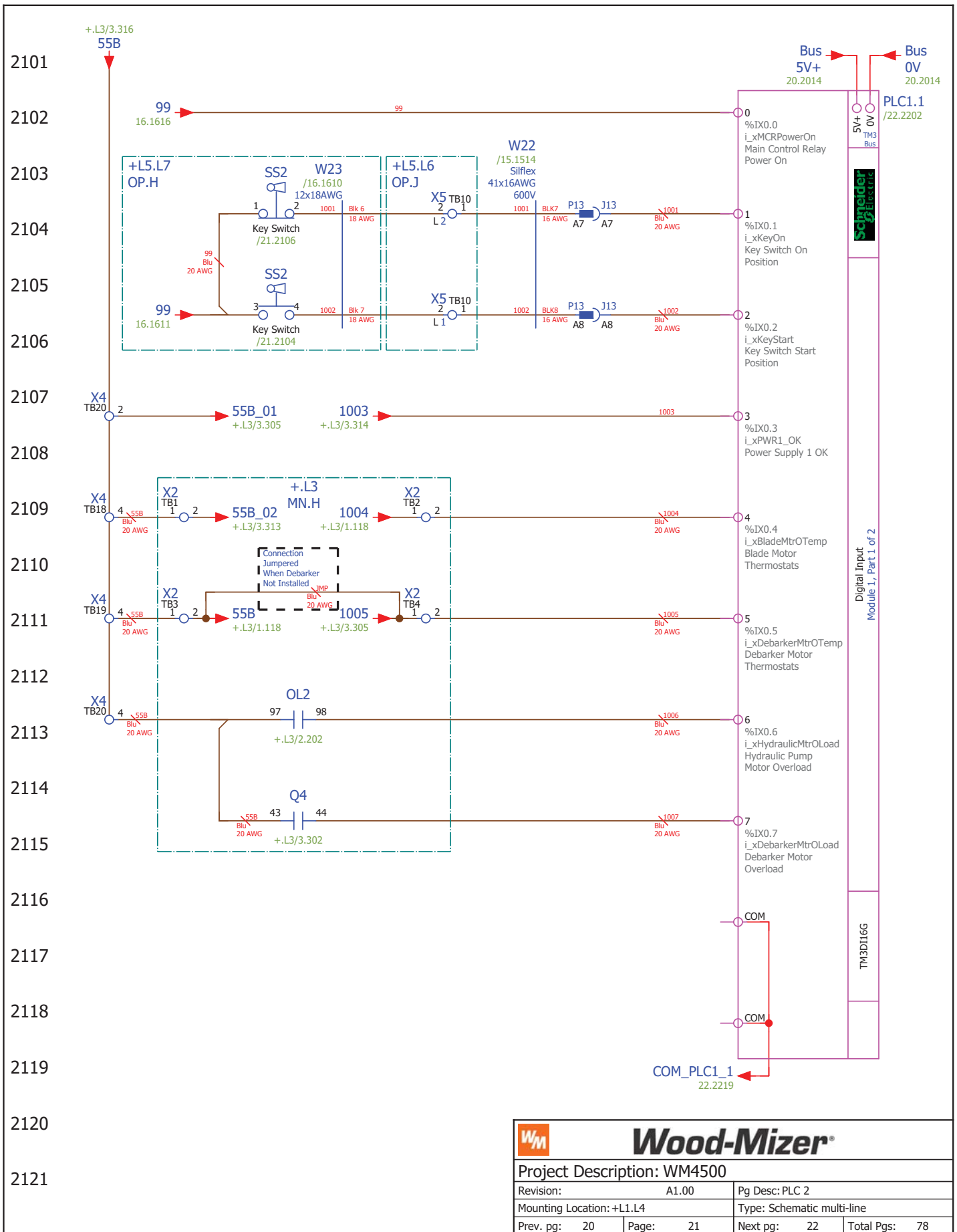

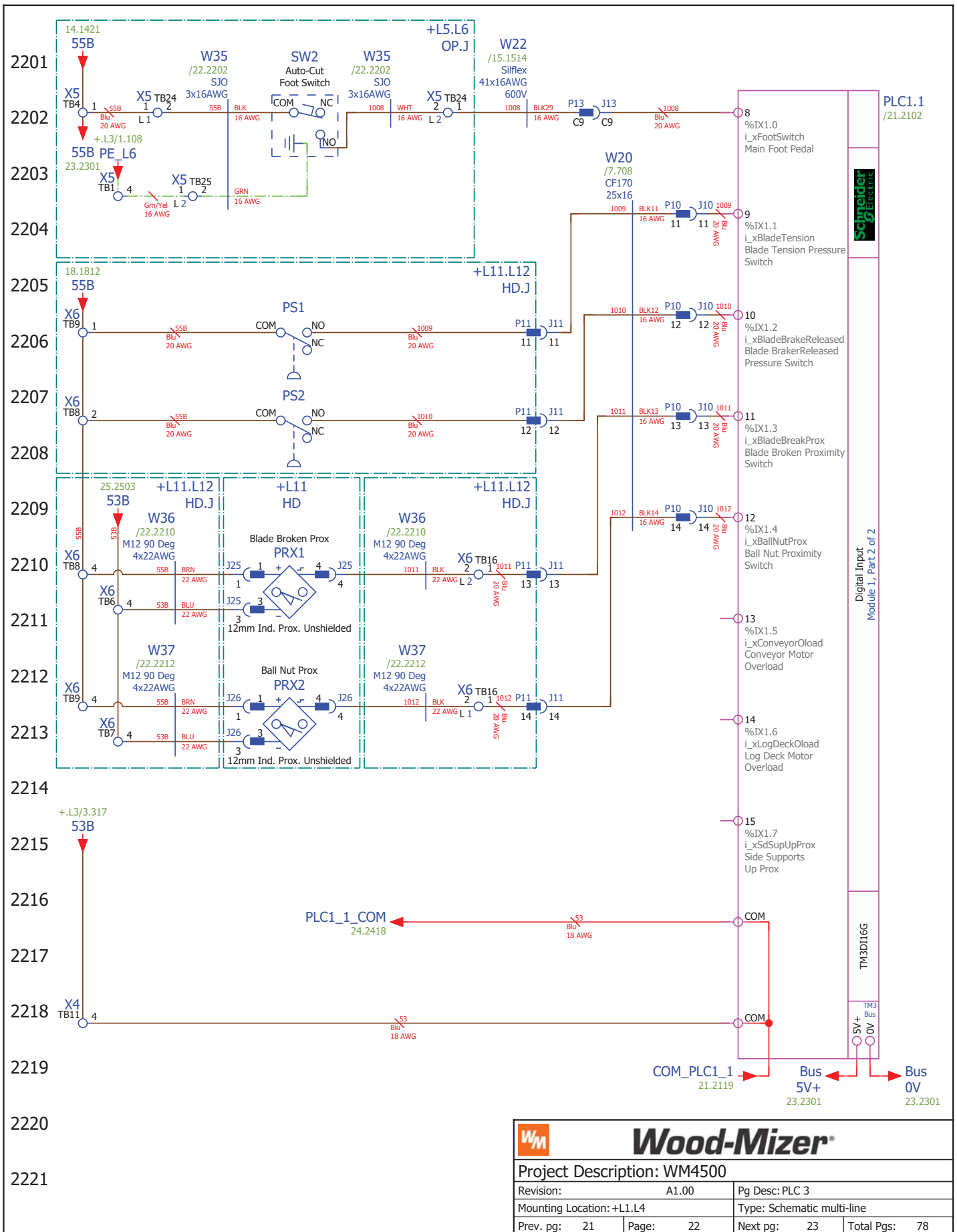

Wood-Mizer®			
Project Description: WM4500			
Revision:	A1.00	Pg Desc: PLC 3	
Mounting Location:	+L1.L4	Type: Schematic multi-line	
Prev. pg:	21	Page:	22
		Next pg:	23
		Total Pgs:	78

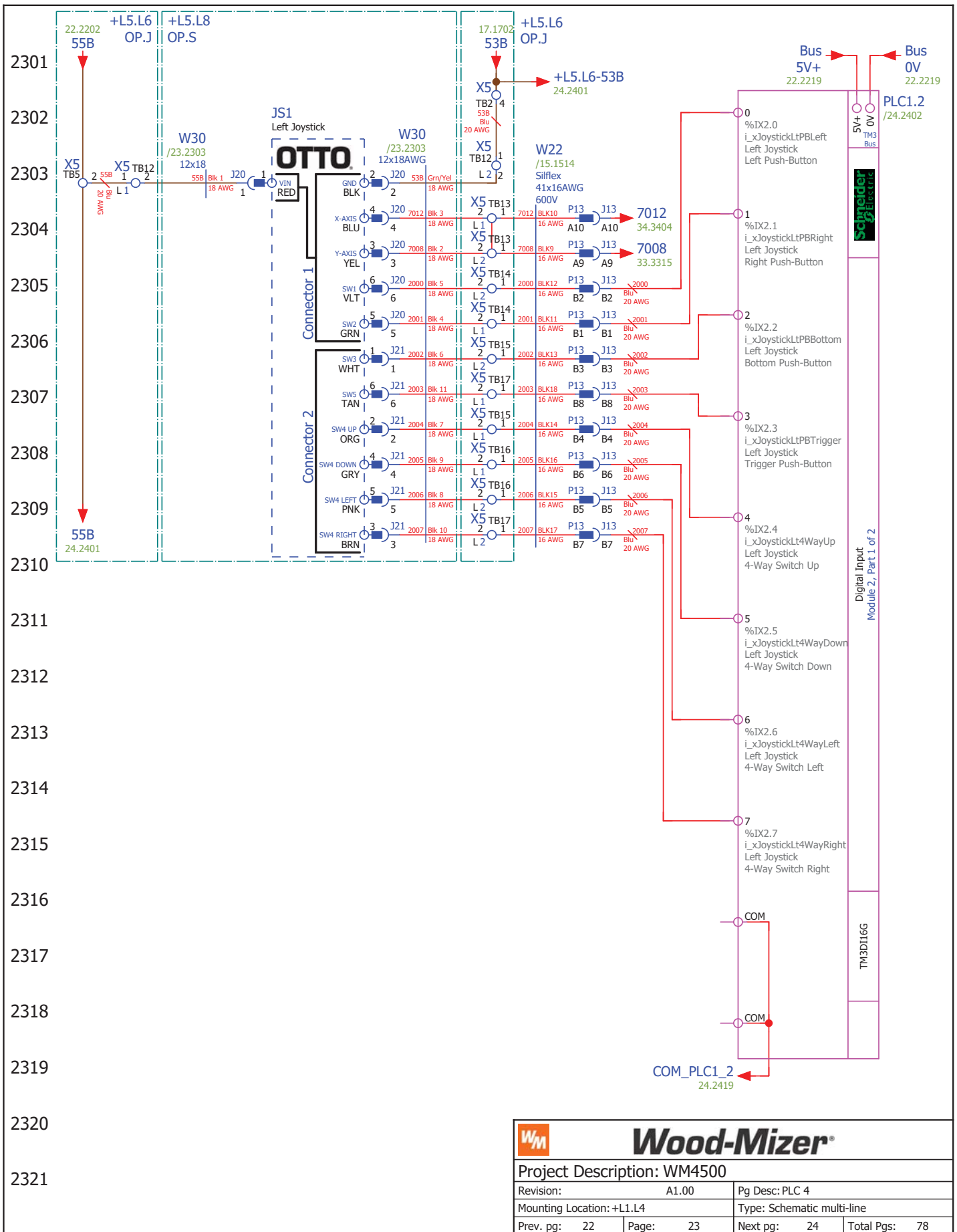

Project Description: WM4500			
Revision:	A1.00	Pg Desc: PLC 4	
Mounting Location:	+L1.L4	Type: Schematic multi-line	
Prev. pg:	22	Page:	23
		Next pg:	24
		Total Pgs:	78

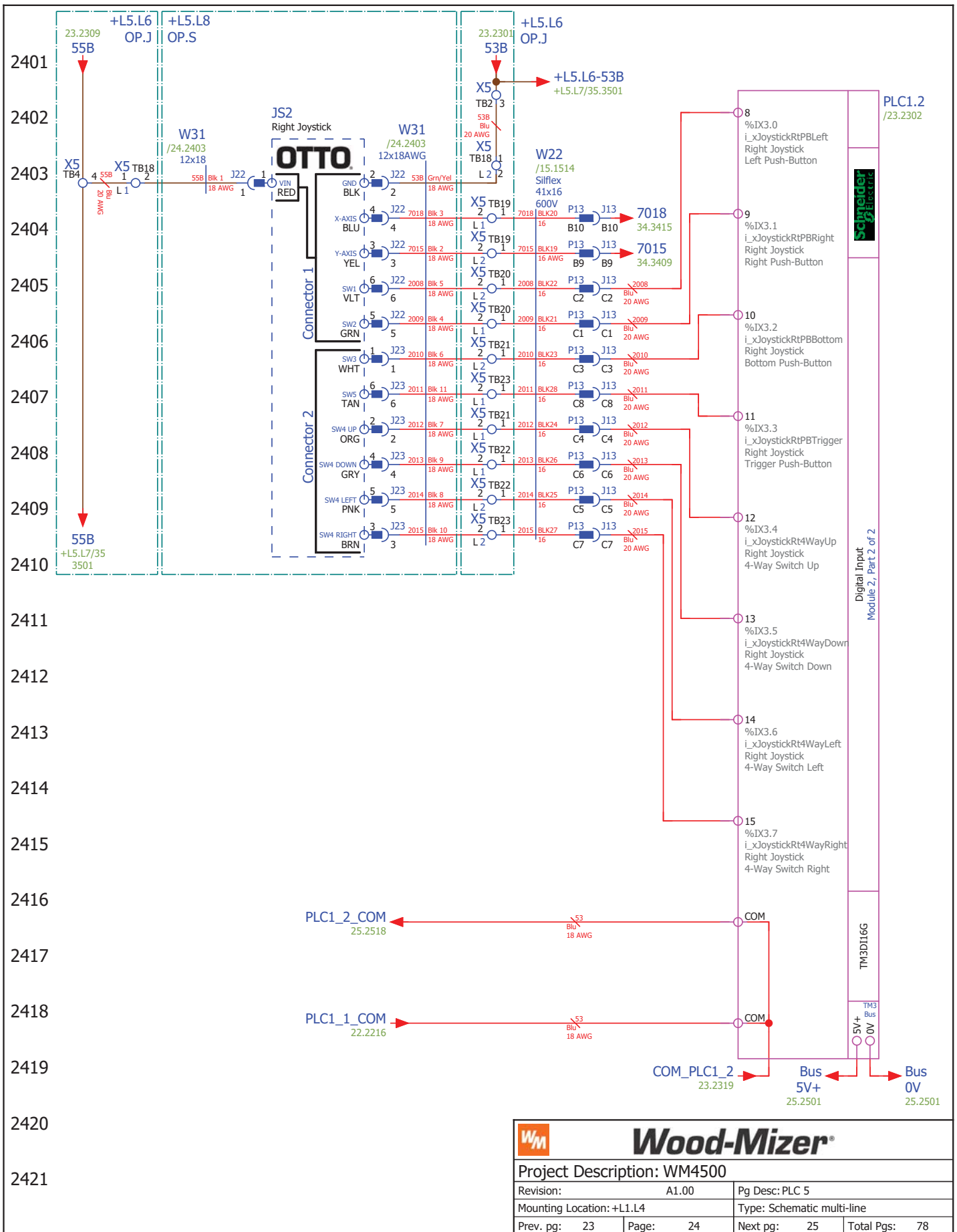

Wood-Mizer®			
Project Description: WM4500			
Revision:	A1.00	Pg Desc: PLC 5	
Mounting Location:	+L1.L4	Type: Schematic multi-line	
Prev. pg:	23	Page:	24
		Next pg:	25
		Total Pgs:	78

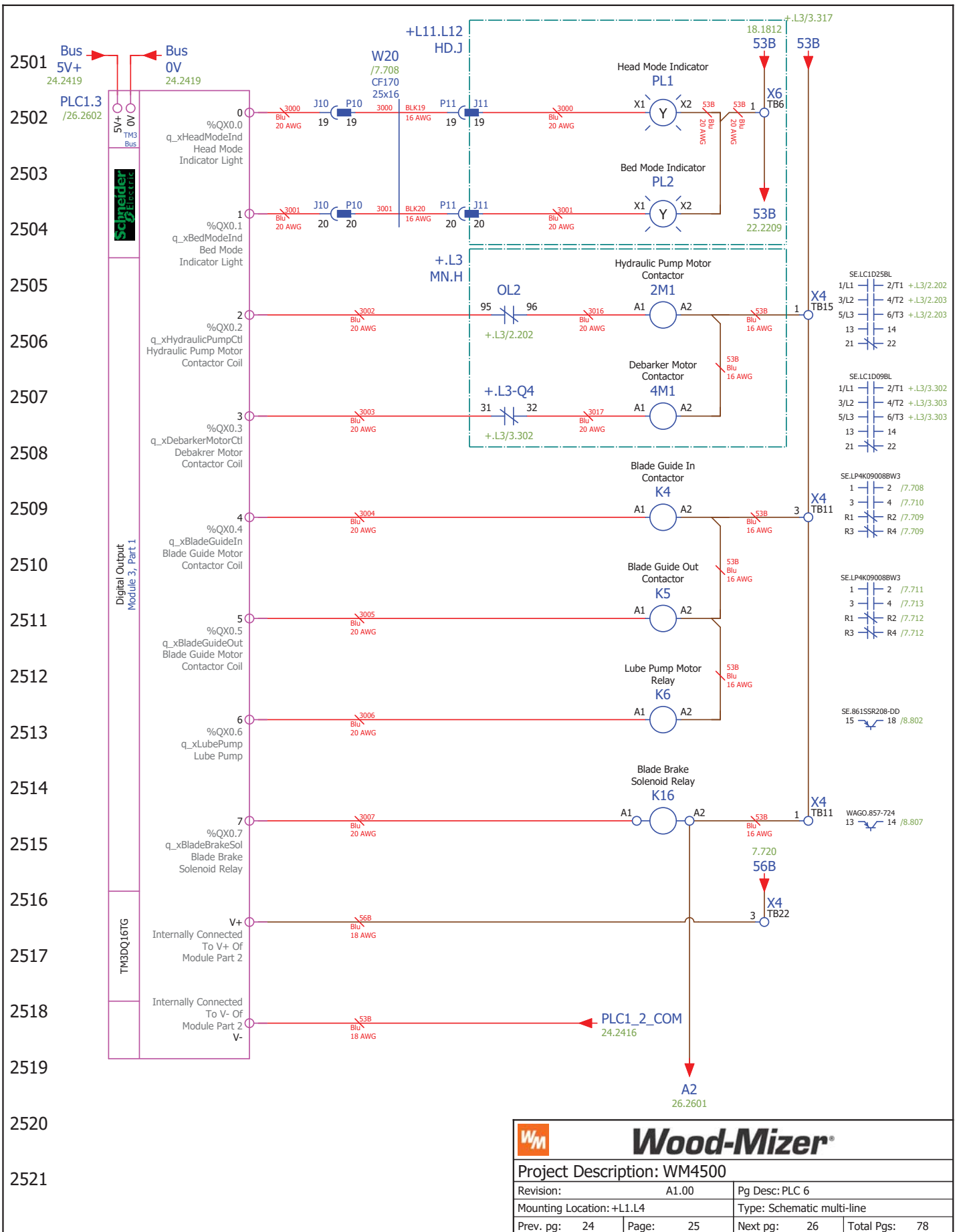

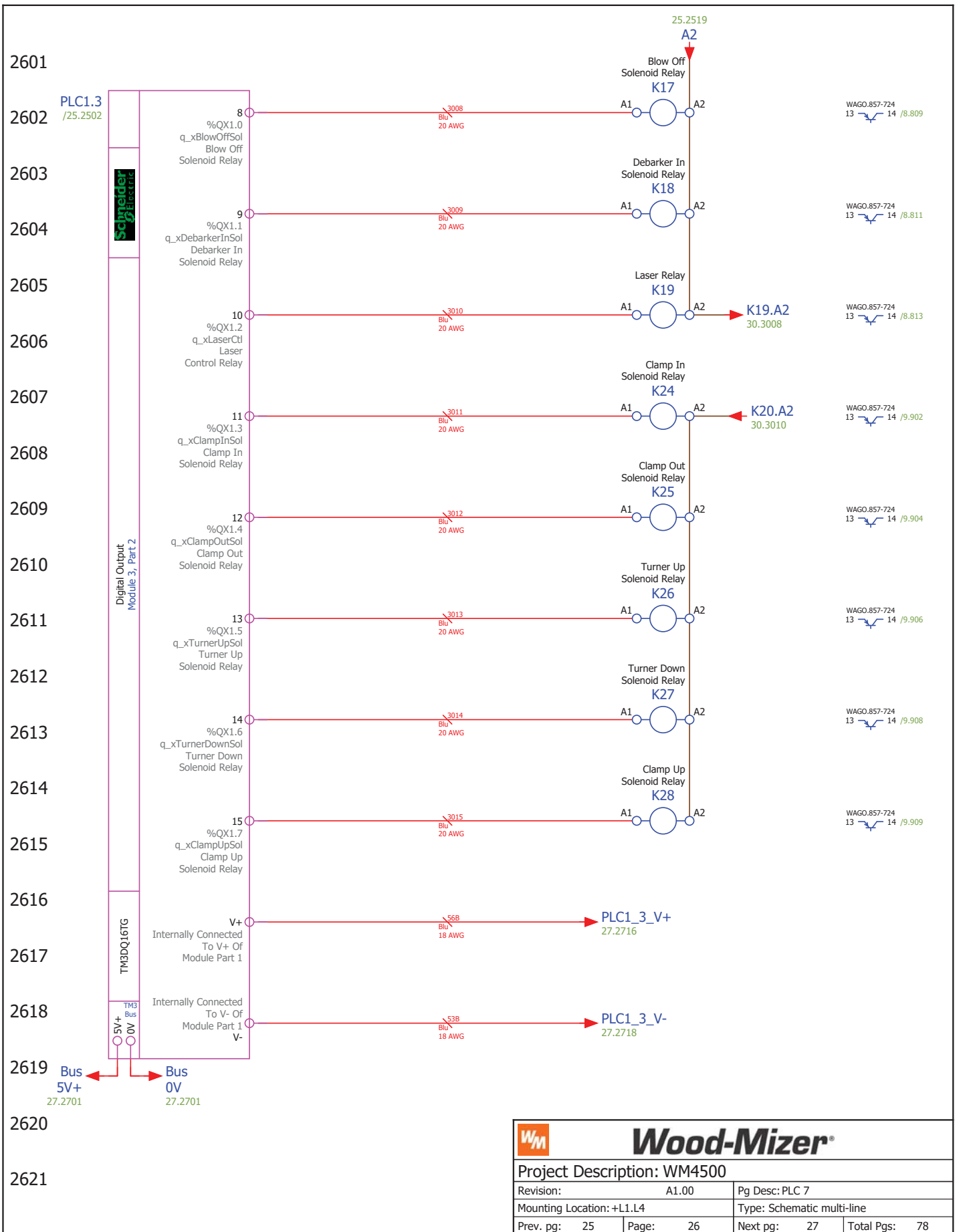

Wood-Mizer®			
Project Description: WM4500			
Revision:	A1.00	Pg Desc: PLC 7	
Mounting Location:	+L1.L4	Type: Schematic multi-line	
Prev. pg:	25	Page:	26
		Next pg:	27
		Total Pgs:	78

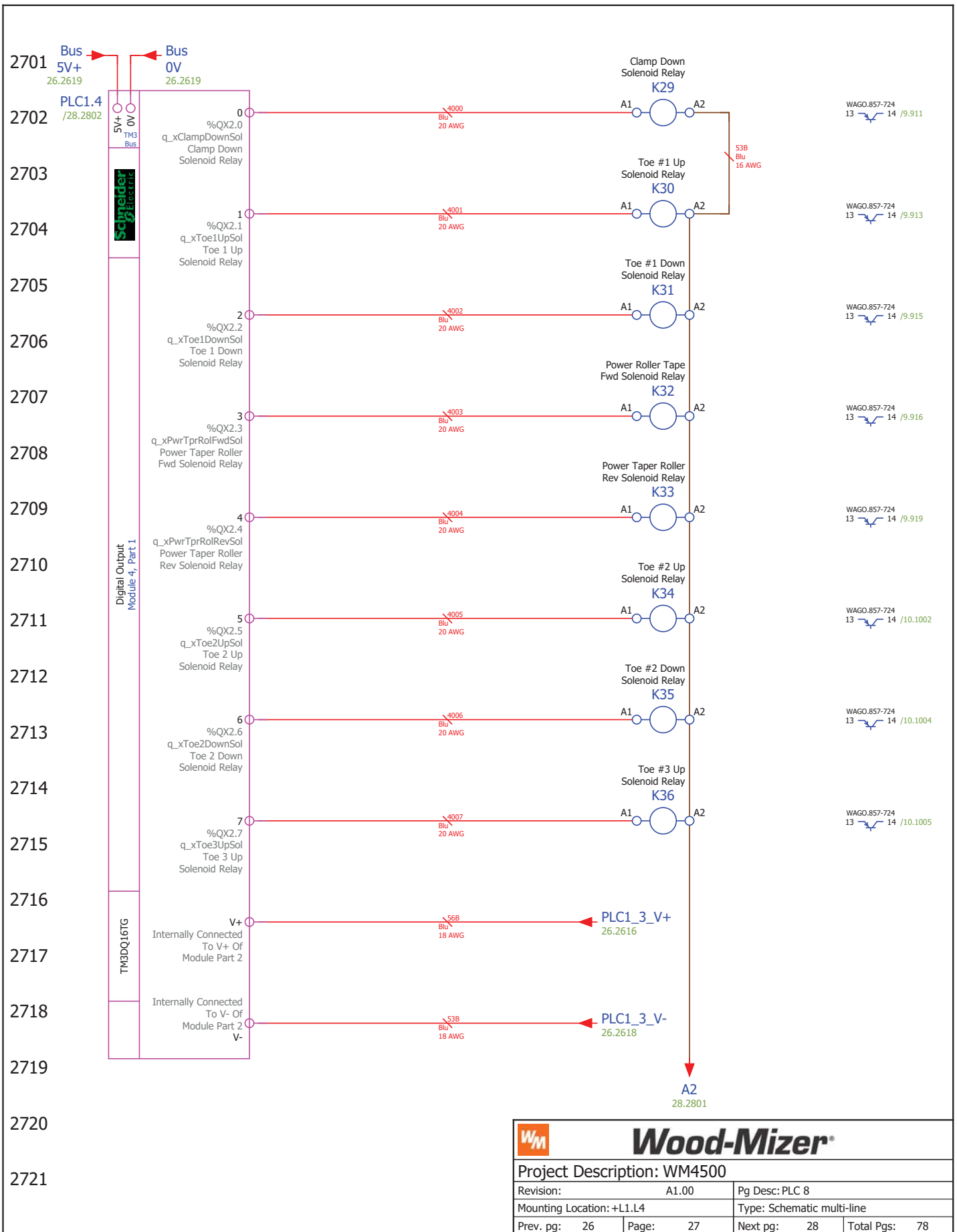

Wood-Mizer®	
Project Description: WM4500	
Revision: A1.00	Pg Desc: PLC 8
Mounting Location: +L1.L4	Type: Schematic multi-line
Prev. pg: 26	Page: 27
Next pg: 28	Total Pgs: 78

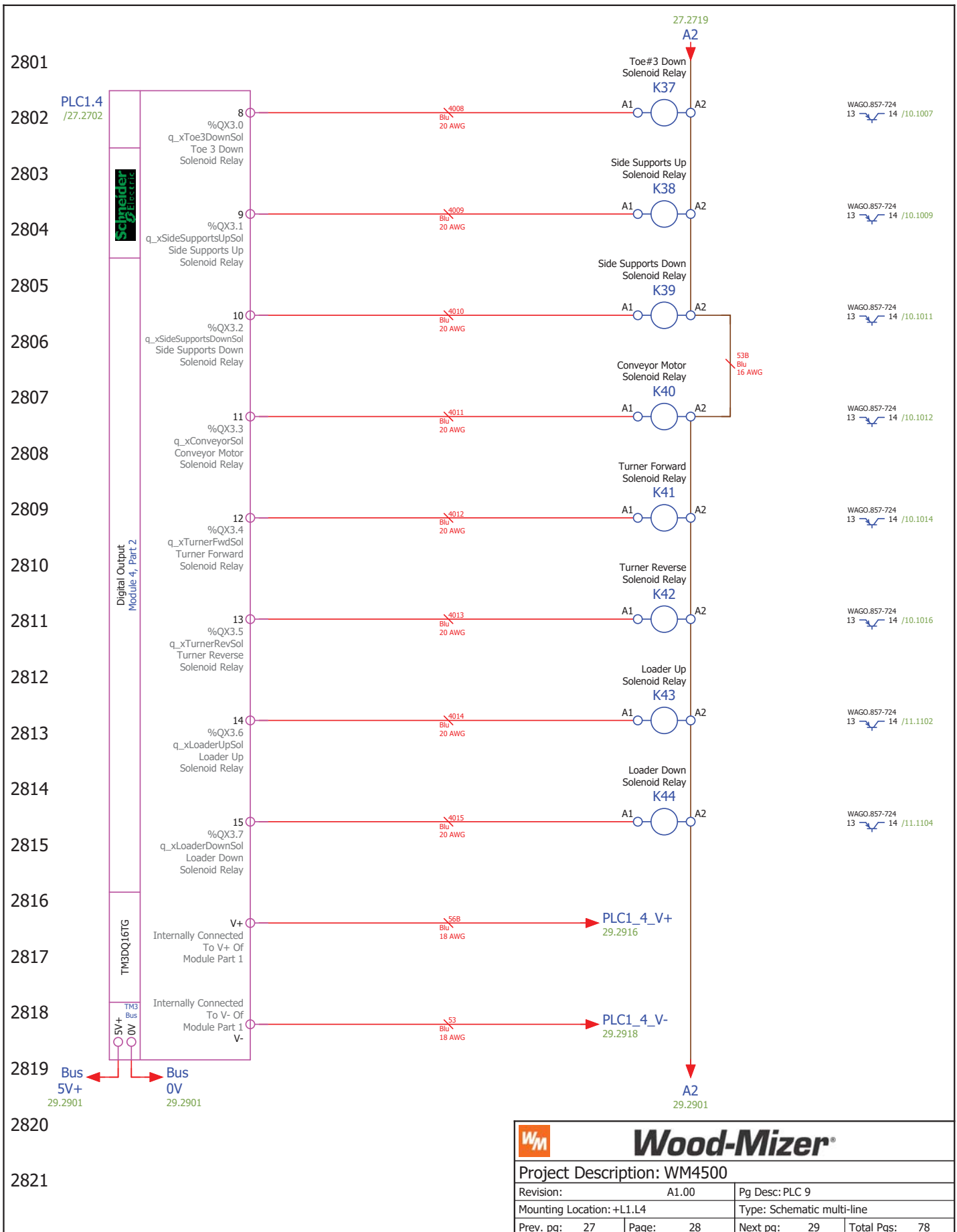

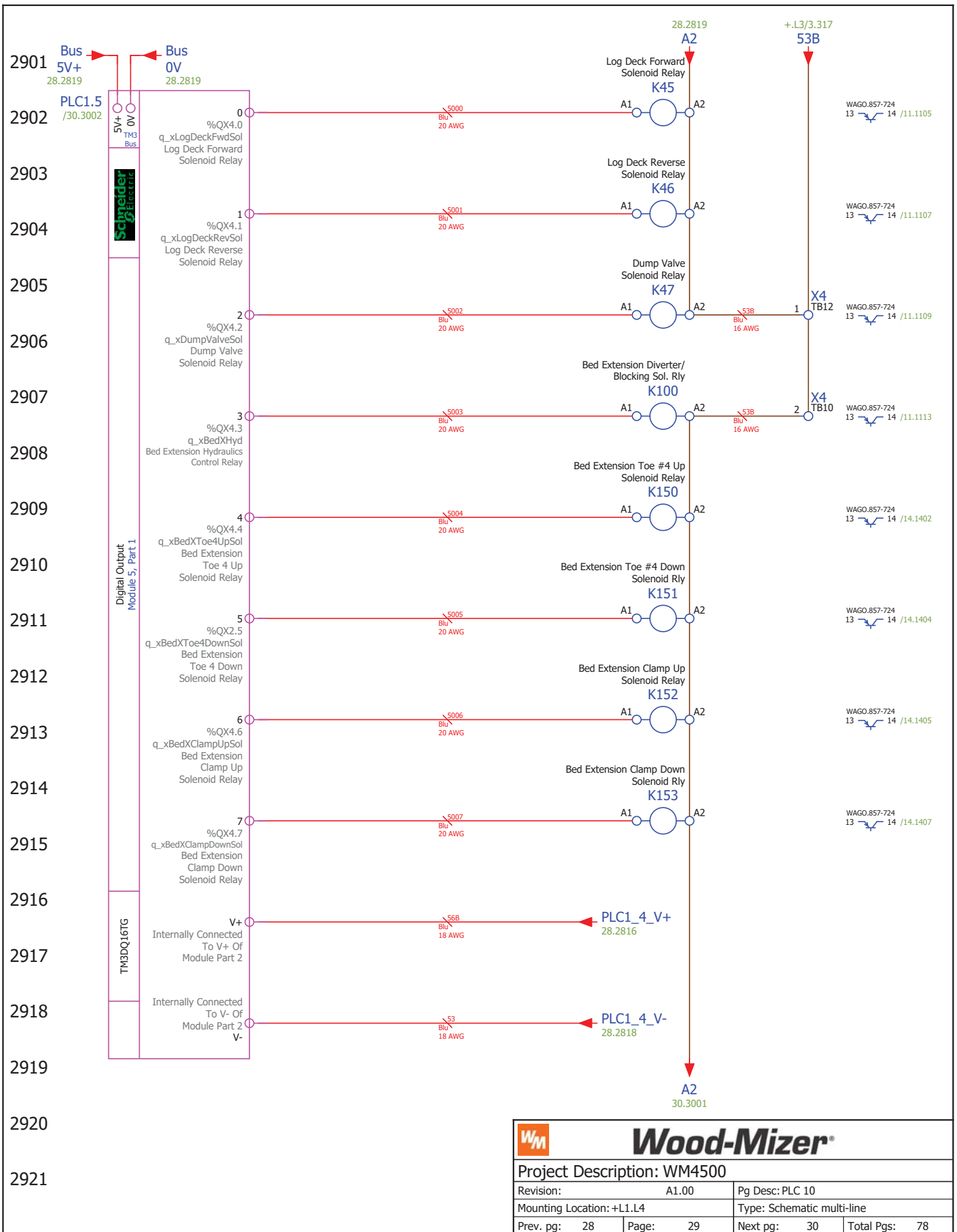



Wood-Mizer®

Project Description: WM4500

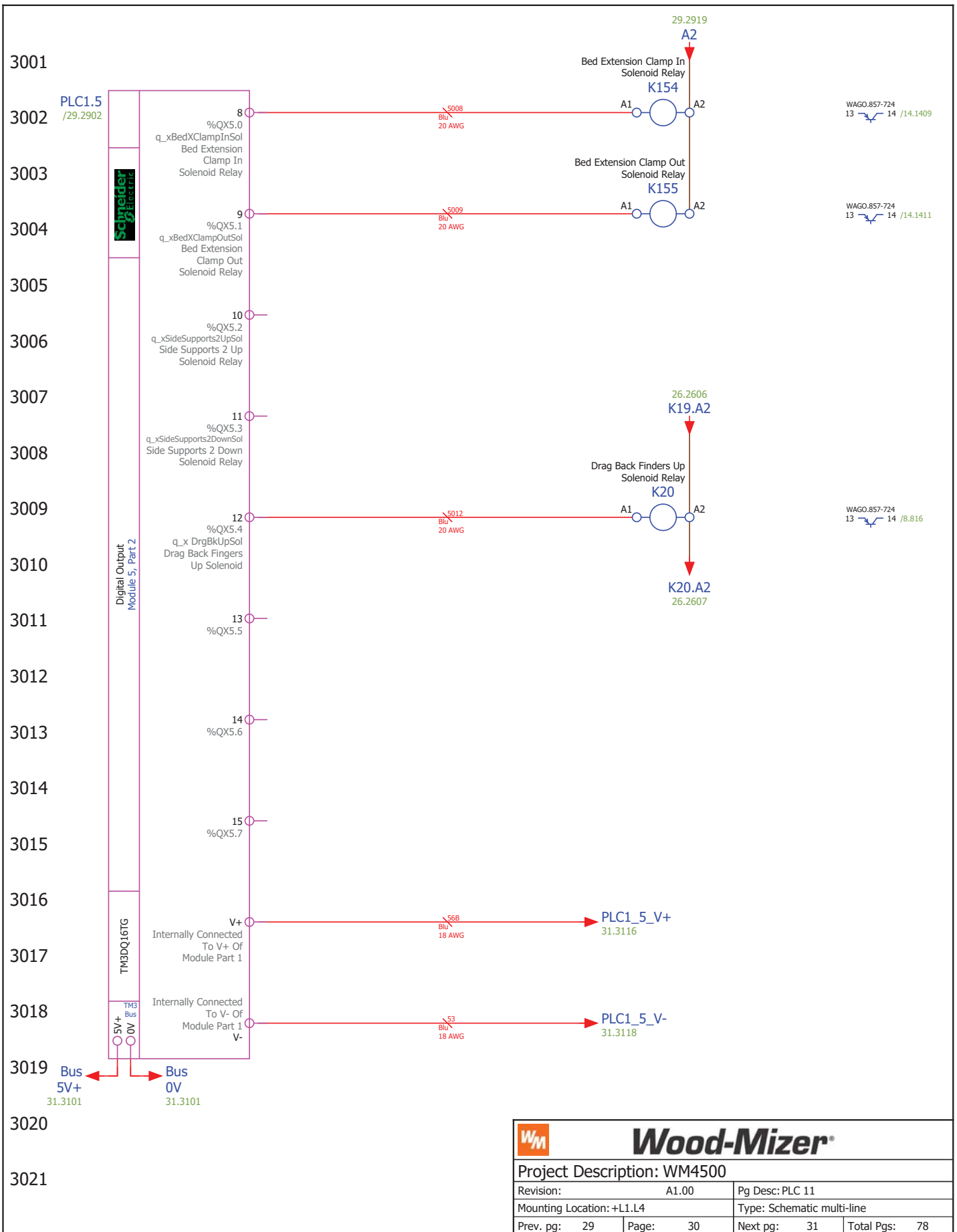
Revision:	A1.00	Pg Desc:	PLC 10
Mounting Location:	+L1.L4	Type:	Schematic multi-line
Prev. pg:	28	Page:	29
		Next pg:	30
		Total Pgs:	78



 Wood-Mizer®		Project Description: WM4500	
		Revision: A1.00	Pg Desc: PLC 11
Mounting Location: +L1.L4		Type: Schematic multi-line	
Prev. pg: 29	Page: 30	Next pg: 31	Total Pgs: 78

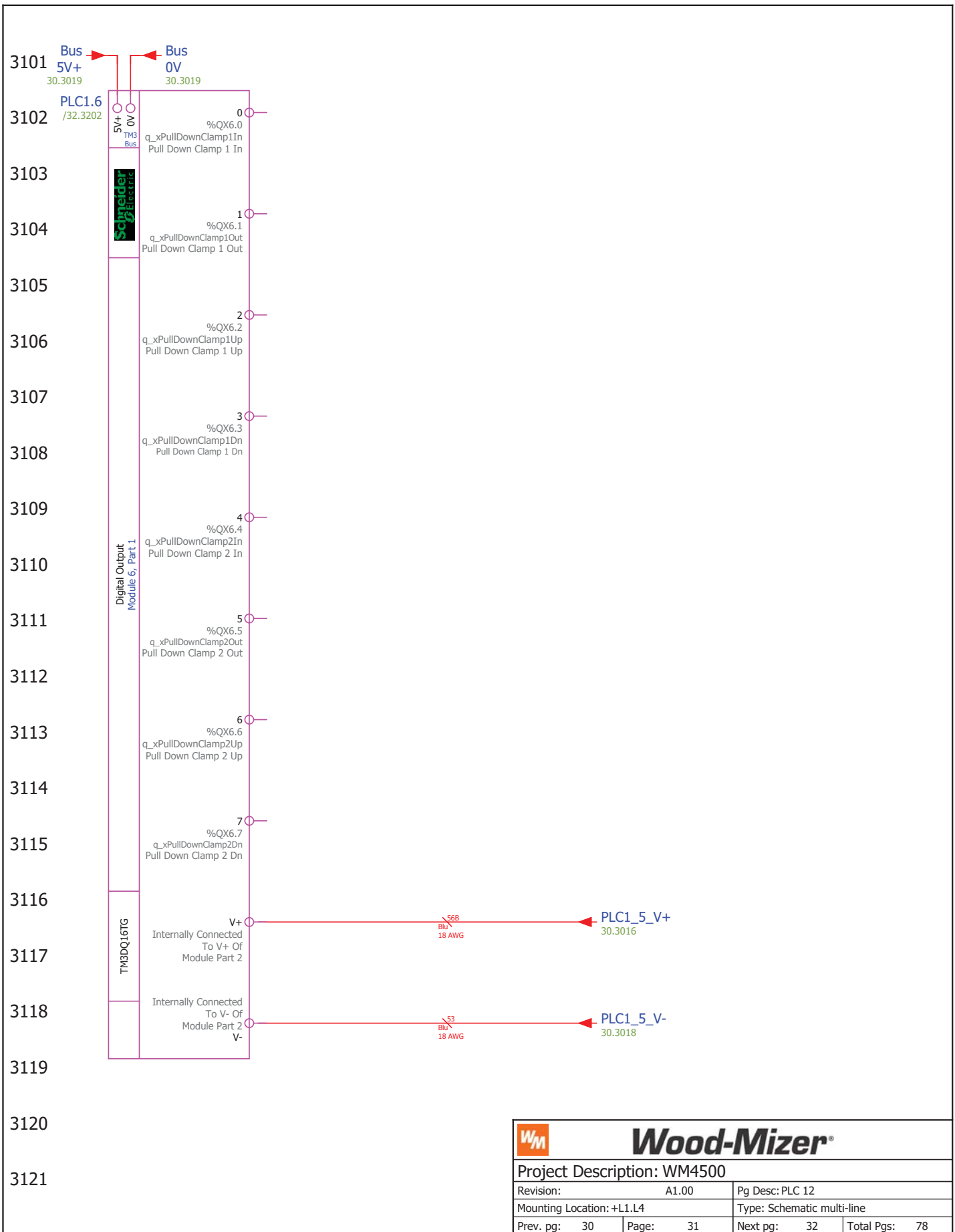

 Wood-Mizer®	
Project Description: WM4500	
Revision: A1.00	Pg Desc: PLC 12
Mounting Location: +L1.L4	Type: Schematic multi-line
Prev. pg: 30	Page: 31
Next pg: 32	Total Pgs: 78

3201

3202 PLC1.6
/31.3102

3203

3204

3205

3206

3207

3208

3209

3210

3211

3212

3213

3214

3215

3216

3217

3218

3219

3220

3221

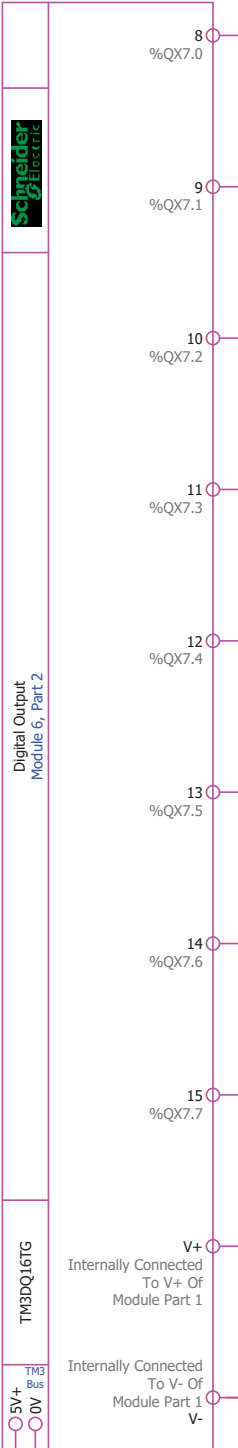

		Wood-Mizer®	
Project Description: WM4500			
Revision:	A1.00	Pg Desc: PLC 13	
Mounting Location: +L1.L4		Type: Schematic multi-line	
Prev. pg:	31	Page:	32
Next pg:	33	Total Pgs:	78

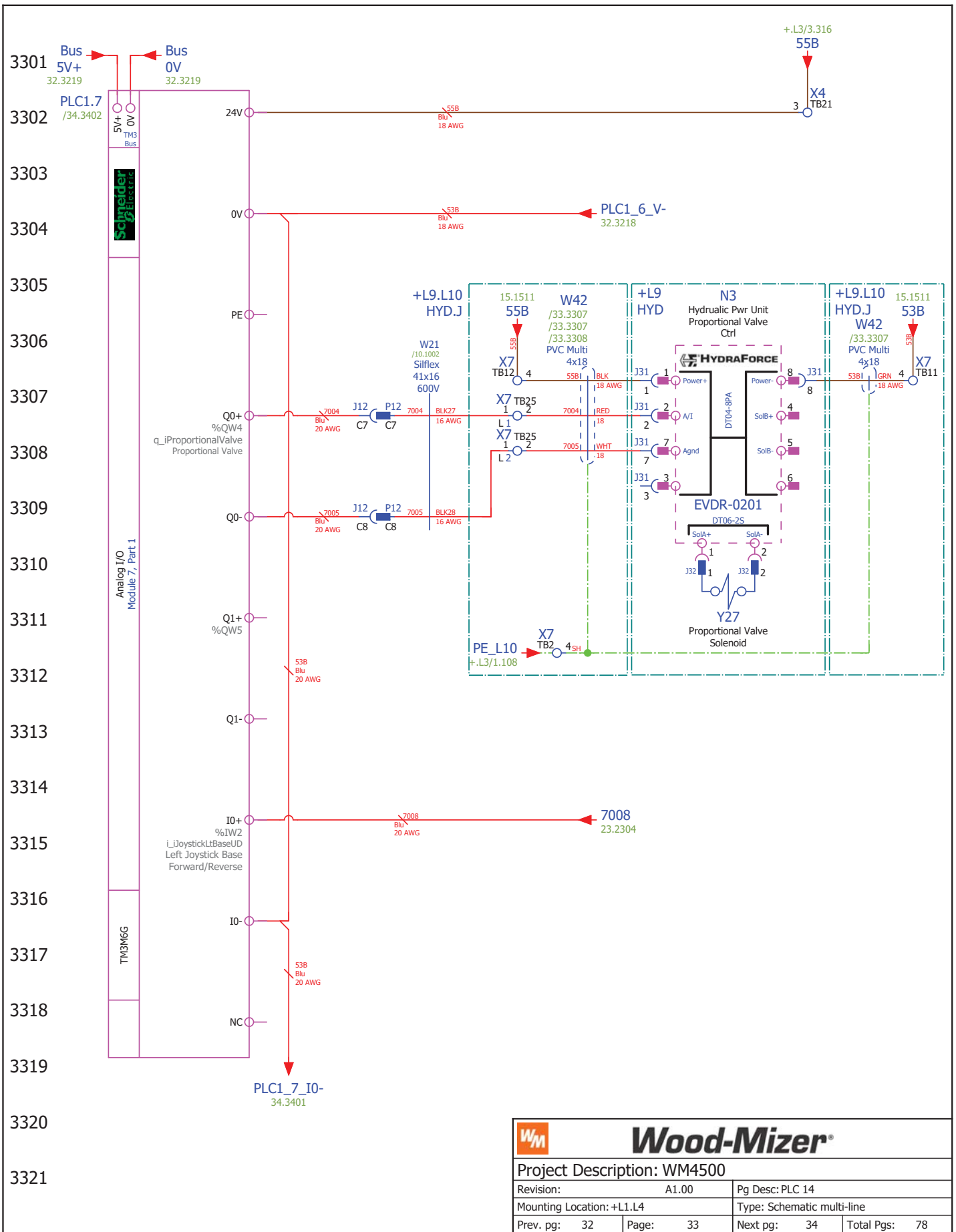

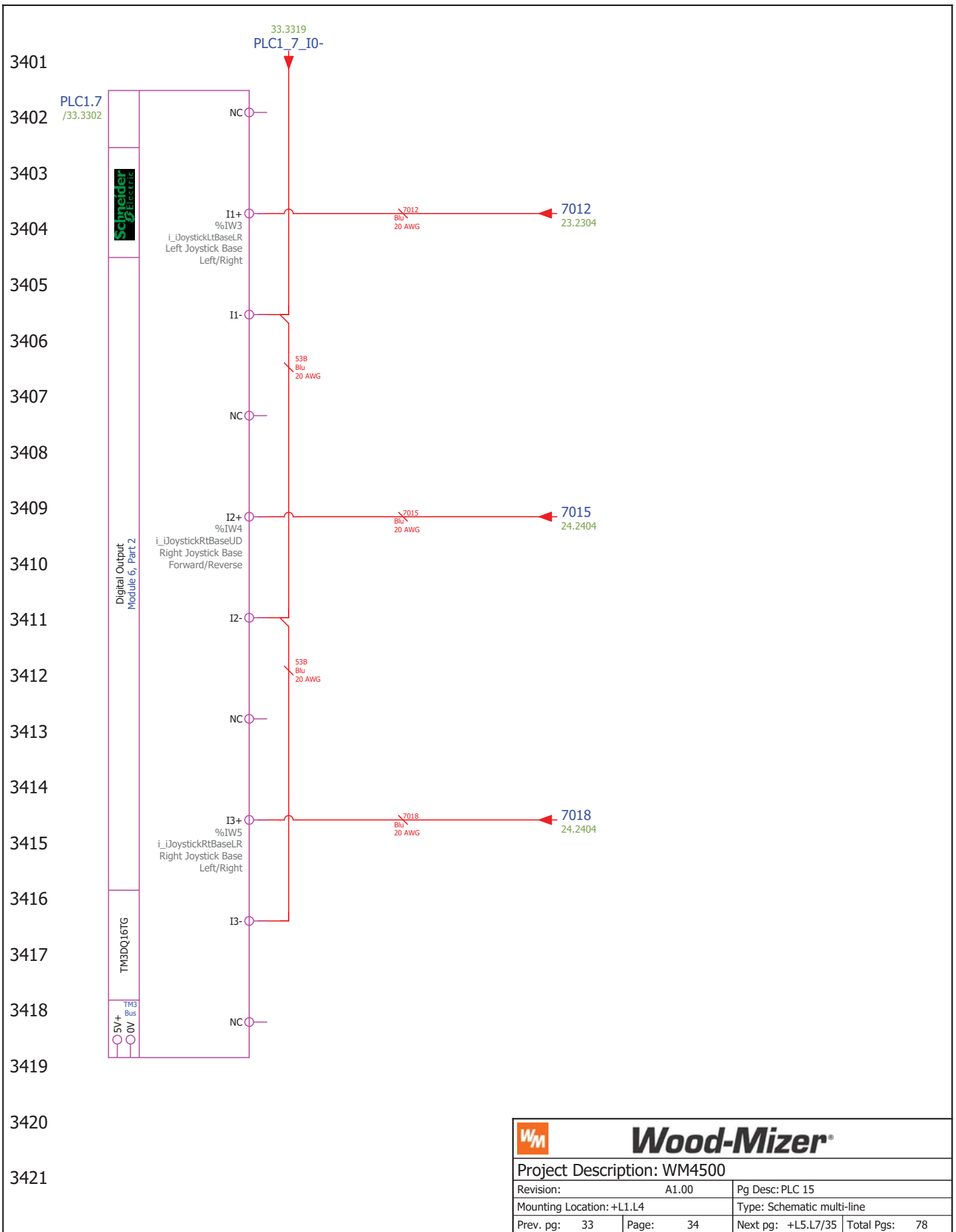

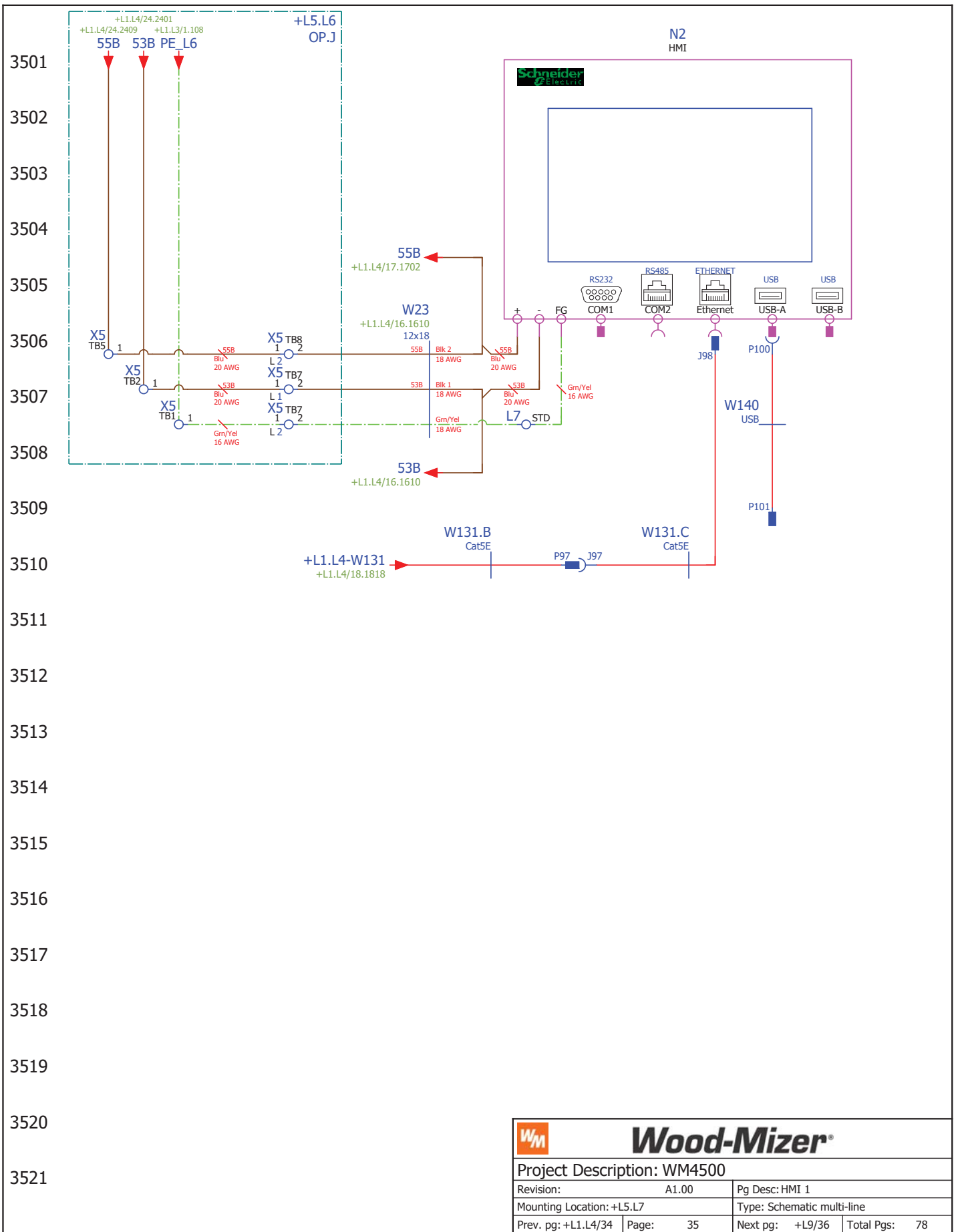

3601
 3602
 3603
 3604
 3605
 3606
 3607
 3608
 3609
 3610
 3611
 3612
 3613
 3614
 3615
 3616
 3617
 3618
 3619
 3620
 3621

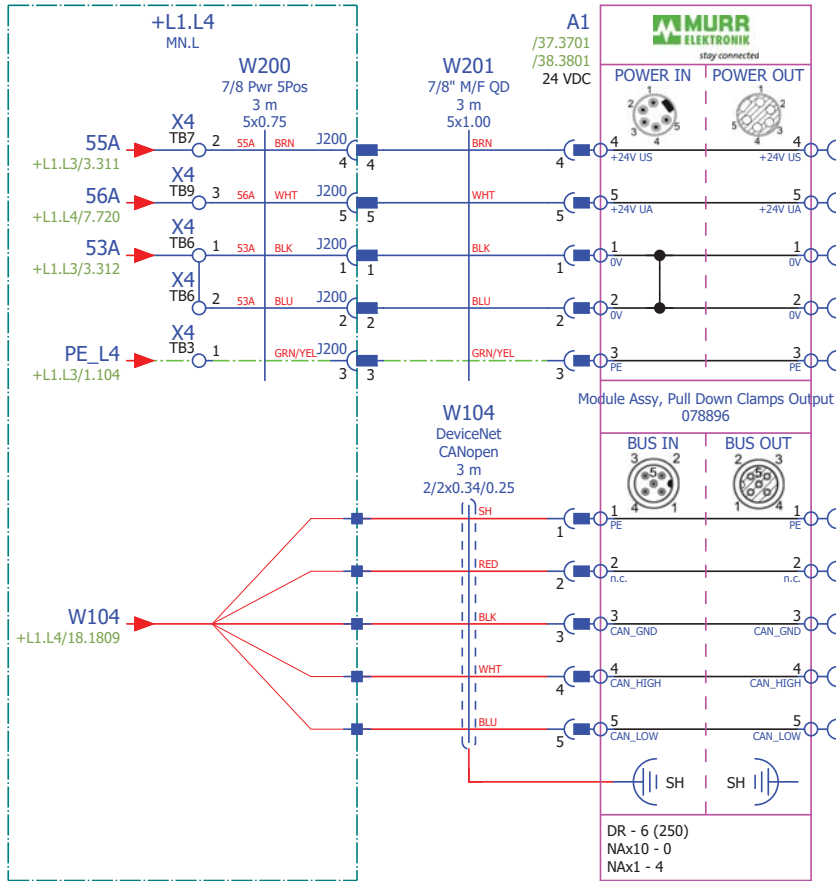

3701

3702 A1
/36.3605
24 VDC

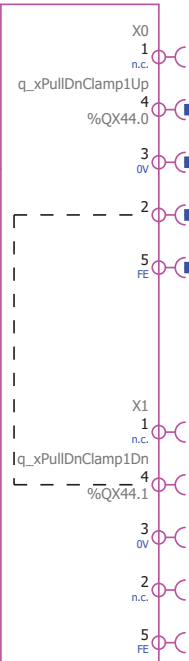

W80
Double Valve
Form A/M12
1 m
4x0.75

Y28

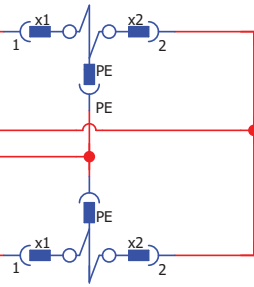

Pull Down
Clamp 1
Up

3703

3704

3705

3706

3707

3708

3709

3710

3711

3712

3713

3714

3715

3716

3717

3718

3719

3720

3721

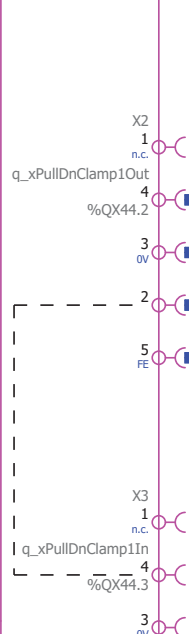

W81
Double Valve
Form A/M12
1 m
4x0.75

Y30

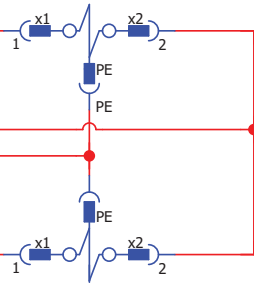

Pull Down
Clamp 1
Out

Y31

Pull Down
Clamp 1
In

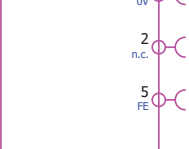

Wood-Mizer®

Project Description: WM4500

Revision:	A1.00	Pg Desc:	Pull Down Clamp 1
Mounting Location:	+L9	Type:	Schematic multi-line
Prev. pg:	36	Page:	37
		Next pg:	38
		Total Pgs:	78

3801

3802 A1
/36.3605
24 VDC

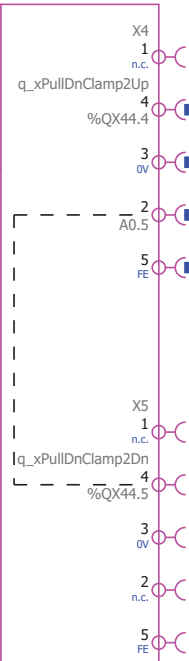

W82
Double Valve
Form A/M12
1 m
4x0.75

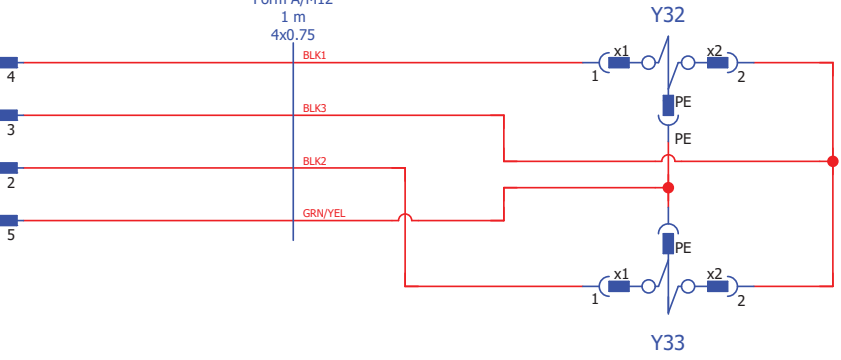

Pull Down
Clamp 2
Up

Pull Down
Clamp 2
Down

3803

3804

3805

3806

3807

3808

3809

3810

3811

3812

3813

3814

3815

3816

3817

3818

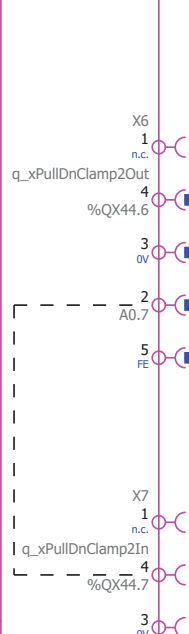

W83
Double Valve
Form A/M12
1 m
4x0.75

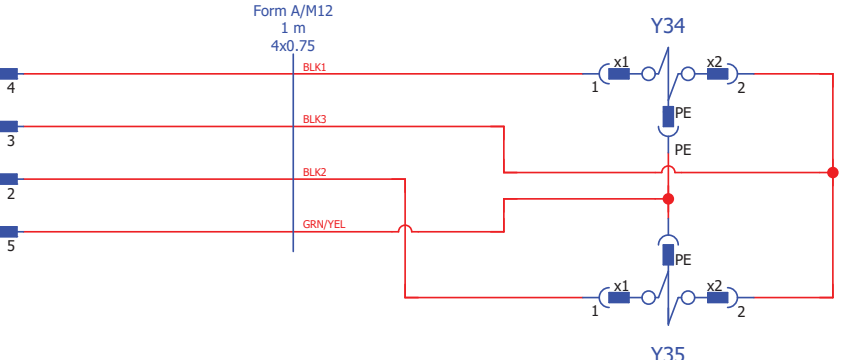

Pull Down
Clamp 2
Up

Pull Down
Clamp 2
Down

078896

3819

3820

3821



Wood-Mizer®

Project Description: WM4500

Revision:	A1.00	Pg Desc: Pull Down Clamp 2
Mounting Location: +L9	Type: Schematic multi-line	
Prev. pg: 37	Page: 38	Next pg: +Docs/C1 Total Pgs: 78

Device Tag/Parts List

WM_PARTS_LIST-Manual

Device tag	Function	Wood-Mizer Part Number	Wood-Mizer Description	Qty.	X-Ref
1M1	Blade Motor Bypass Contactor	052465	Contactora, 32A 3P 24VDC Coil	1	+L1.L4/15.1503
2M1	Hydraulic Pump Motor Contactor	069866	Contactora, 25A 3P 24V Low Pwr Coil	1	+L1.L4/25.2506
4M1	Debarker Motor Contactor	024890	Contactora, 9A 3P 24VDC Coil	1	+L1.L4/25.2507
A1	Pull Down Clamps Output Module	078896	Module Assy, Pull Down Clamps Output	1	+L9/36.3605
CAN1	CANopen Junction Box	069930	PLC Module, CANopen Junction	1	+L1.L4/18.1803
E1	Ethernet Switch	078466	Switch, Ethernet 5 Port 24VDC	1	+L1.L4/18.1816
ENC1	Feed Position Absolute Encoder	112573 ¹	Encoder Assy, Ind. Mill Feed	1	+L1.L4/18.1811
F4	Transformer L1&L3 Fuses	068066	Fuse Holder, 2P Class CC Wire Clamps	1	+L1.L3/3.306
F4	=	069915	Fuse, 0.25A 600V KLR Class CC	2	+L1.L3/3.306
F5	Transformer Output Fuse	068065	Fuse Holder, 1P Class CC Wire Clamps	1	+L1.L3/3.308
F5	=	069915	Fuse, 0.25A 600V KLR Class CC	1	+L1.L3/3.308
F6	Feed Drive L1 Fuse	053717	Fuseholder, 60A Cube	1	+L1.L3/2.208
F6	=	069702	Fuse, 40A Class J Cube	1	+L1.L3/2.208
F7	Feed Drive L2 Fuse	053717	Fuseholder, 60A Cube	1	+L1.L3/2.209
F7	=	069702	Fuse, 40A Class J Cube	1	+L1.L3/2.209
F8	Feed Drive L3 Fuse	053717	Fuseholder, 60A Cube	1	+L1.L3/2.209
F8	=	069702	Fuse, 40A Class J Cube	1	+L1.L3/2.209
F9	Power Supply 1 L1&L3 Fuses	068066	Fuse Holder, 2P Class CC Wire Clamps	1	+L1.L3/3.311
F9	=	052381	Fuse, 8A 600V Class CC Delay	2	+L1.L3/3.311
F10	Power Supply 2 L1&L3 Fuses	068066	Fuse Holder, 2P Class CC Wire Clamps	1	+L1.L3/3.316
F10	=	052713	Fuse, 4A 600V Class CC Delay	2	+L1.L3/3.316
F11	Hydraulic Pump Motor L1 Fuse	053736	Fuseholder, Cube 30A	1	+L1.L3/2.202
F11	=	053737	Fuse, 30A Class J Cube	1	+L1.L3/2.202
F12	Hydraulic Pump Motor L2 Fuse	053736	Fuseholder, Cube 30A	1	+L1.L3/2.203
F12	=	053737	Fuse, 30A Class J Cube	1	+L1.L3/2.203
F13	Hydraulic Pump Motor L3 Fuse	053736	Fuseholder, Cube 30A	1	+L1.L3/2.203
F13	=	053737	Fuse, 30A Class J Cube	1	+L1.L3/2.203
F14	Up/Down Servo Drive L1 Fuse	053736	Fuseholder, Cube 30A	1	+L1.L3/2.216
F14	=	053737	Fuse, 30A Class J Cube	1	+L1.L3/2.216
F15	Up/Down Servo Drive L2 Fuse	053736	Fuseholder, Cube 30A	1	+L1.L3/2.217
F15	=	053737	Fuse, 30A Class J Cube	1	+L1.L3/2.217
F16	Up/Down Servo Drive L3 Fuse	053736	Fuseholder, Cube 30A	1	+L1.L3/2.218
F16	=	053737	Fuse, 30A Class J Cube	1	+L1.L3/2.218
F17	Blade Motor L1 Fuse	053586	Fuseholder, 100A Cube	1	+L1.L3/1.117
F17	=	069708	Fuse, 60A Class J Cube	1	+L1.L3/1.117
F18	Blade Motor L2 Fuse	053586	Fuseholder, 100A Cube	1	+L1.L3/1.116
F18	=	069708	Fuse, 60A Class J Cube	1	+L1.L3/1.116
F19	Blade Motor L3 Fuse	053586	Fuseholder, 100A Cube	1	+L1.L3/1.116
F19	=	069708	Fuse, 60A Class J Cube	1	+L1.L3/1.116
G1	DC Motor/ Solenoids Power Supply	078012	Power Supply, 24VDC 20A 200-500V	1	+L1.L3/3.310
G2	Control Power Supply	078193	Power Supply, 24VDC 10A 200-500V	1	+L1.L3/3.315
HM1	Blade Motor Hour Meter	P09631	Meter, Hour	1	+L1.L4/15.1507
JS1	Left Joystick	078360	Joystick, 4-Button w/4-Way Switch	1	+L1.L4/23.2302
JS2	Right Joystick	078360	Joystick, 4-Button w/4-Way Switch	1	+L1.L4/24.2402
K1	Isolation Contactor	069886	Contactora, 115A 3P 24VDC Coil	1	+L1.L4/15.1502
K2	Aux. E-Stop Control	101241	Contactora, 9A 3P 24VDC 1NO	1	+L1.L4/17.1702
K4	Blade Guide In Contactor	024910	Contactora, 9A 2NC 2NO 24VDC Reversing	1	+L1.L4/25.2509
K5	Blade Guide Out Contactor	024910	Contactora, 9A 2NC 2NO 24VDC Reversing	1	+L1.L4/25.2511
K6	Lube Pump Motor Relay	069943	Relay, Solid State 8A DIN	1	+L1.L4/25.2513
K16	Blade Brake Solenoid Relay	068212	Relay, Solid State 2A 24VDC Coil Cage Clamp Base	1	+L1.L4/25.2515
K17	Blow Off Solenoid Relay	068212	Relay, Solid State 2A 24VDC Coil Cage Clamp Base	1	+L1.L4/26.2602
K18	Debarker In Solenoid Relay	068212	Relay, Solid State 2A 24VDC Coil Cage Clamp Base	1	+L1.L4/26.2604
K19	Laser Relay	068212	Relay, Solid State 2A 24VDC Coil Cage Clamp Base	1	+L1.L4/26.2606
K20	Drag Back Finders Up Solenoid Relay	068212	Relay, Solid State 2A 24VDC Coil Cage Clamp Base	1	+L1.L4/30.3009
K24	Clamp In Solenoid Relay	068212	Relay, Solid State 2A 24VDC Coil Cage Clamp Base	1	+L1.L4/26.2607
K25	Clamp Out Solenoid Relay	068212	Relay, Solid State 2A 24VDC Coil Cage Clamp Base	1	+L1.L4/26.2609
K26	Turner Up Solenoid Relay	068212	Relay, Solid State 2A 24VDC Coil Cage Clamp Base	1	+L1.L4/26.2611

¹ 112573 replaced 06046 after 9/27/2022 per ECN 38745.

		Wood-Mizer®	
Project Description: WM4500			
Revision:	A1.00	Pg Desc: Parts list	
Mounting Location: +Docs		Type: Parts list	
Prev. pg:	+L9/38	Page:	C1
Next pg:	C2	Total Pgs:	78

Device Tag/Parts List

WM_PARTS_LIST-Manual

Device tag	Function	Wood-Mizer Part Number	Wood-Mizer Description	Qty.	X-Ref
K27	Turner Down Solenoid Relay	068212	Relay, Solid State 2A 24VDC Coil Cage Clamp Base	1	+L1.L4/26.2613
K28	Clamp Up Solenoid Relay	068212	Relay, Solid State 2A 24VDC Coil Cage Clamp Base	1	+L1.L4/26.2615
K29	Clamp Down Solenoid Relay	068212	Relay, Solid State 2A 24VDC Coil Cage Clamp Base	1	+L1.L4/27.2702
K30	Toe #1 Up Solenoid Relay	068212	Relay, Solid State 2A 24VDC Coil Cage Clamp Base	1	+L1.L4/27.2704
K31	Toe #1 Down Solenoid Relay	068212	Relay, Solid State 2A 24VDC Coil Cage Clamp Base	1	+L1.L4/27.2706
K32	Power Roller Tape Fwd Solenoid Relay	068212	Relay, Solid State 2A 24VDC Coil Cage Clamp Base	1	+L1.L4/27.2707
K33	Power Taper Roller Rev Solenoid Relay	068212	Relay, Solid State 2A 24VDC Coil Cage Clamp Base	1	+L1.L4/27.2709
K34	Toe #2 Up Solenoid Relay	068212	Relay, Solid State 2A 24VDC Coil Cage Clamp Base	1	+L1.L4/27.2711
K35	Toe #2 Down Solenoid Relay	068212	Relay, Solid State 2A 24VDC Coil Cage Clamp Base	1	+L1.L4/27.2713
K36	Toe #3 Up Solenoid Relay	068212	Relay, Solid State 2A 24VDC Coil Cage Clamp Base	1	+L1.L4/27.2715
K37	Toe#3 Down Solenoid Relay	068212	Relay, Solid State 2A 24VDC Coil Cage Clamp Base	1	+L1.L4/28.2802
K38	Side Supports Up Solenoid Relay	068212	Relay, Solid State 2A 24VDC Coil Cage Clamp Base	1	+L1.L4/28.2804
K39	Side Supports Down Solenoid Relay	068212	Relay, Solid State 2A 24VDC Coil Cage Clamp Base	1	+L1.L4/28.2806
K40	Conveyor Motor Solenoid Relay	068212	Relay, Solid State 2A 24VDC Coil Cage Clamp Base	1	+L1.L4/28.2807
K41	Turner Forward Solenoid Relay	068212	Relay, Solid State 2A 24VDC Coil Cage Clamp Base	1	+L1.L4/28.2809
K42	Turner Reverse Solenoid Relay	068212	Relay, Solid State 2A 24VDC Coil Cage Clamp Base	1	+L1.L4/28.2811
K43	Loader Up Solenoid Relay	068212	Relay, Solid State 2A 24VDC Coil Cage Clamp Base	1	+L1.L4/28.2813
K44	Loader Down Solenoid Relay	068212	Relay, Solid State 2A 24VDC Coil Cage Clamp Base	1	+L1.L4/28.2815
K45	Log Deck Forward Solenoid Relay	068212	Relay, Solid State 2A 24VDC Coil Cage Clamp Base	1	+L1.L4/29.2902
K46	Log Deck Reverse Solenoid Relay	068212	Relay, Solid State 2A 24VDC Coil Cage Clamp Base	1	+L1.L4/29.2904
K47	Dump Valve Solenoid Relay	068212	Relay, Solid State 2A 24VDC Coil Cage Clamp Base	1	+L1.L4/29.2906
K100	Bed Extension Diverter/ Blocking Sol. Rly	068212	Relay, Solid State 2A 24VDC Coil Cage Clamp Base	1	+L1.L4/29.2907
K101	Bed Ext Turner Fwd/ Rev Diverter Relay	068212	Relay, Solid State 2A 24VDC Coil Cage Clamp Base	1	+L1.L4/11.1113
K102	Bed Ext Turner Fwd/ Rev Blocking Relay	068212	Relay, Solid State 2A 24VDC Coil Cage Clamp Base	1	+L1.L4/11.1114
K103	Bed Ext Side Support Up/Dn Diverter Rly	068212	Relay, Solid State 2A 24VDC Coil Cage Clamp Base	1	+L1.L4/11.1116
K104	Bed Ext Side Support Up/Dn Blocking Rly	068212	Relay, Solid State 2A 24VDC Coil Cage Clamp Base	1	+L1.L4/11.1117
K105	Bed Ext Turner Up/Dn Diverter Relay	068212	Relay, Solid State 2A 24VDC Coil Cage Clamp Base	1	+L1.L4/12.1202
K106	Bed Ext Pwr Taper Fwd/Rev Diverter Rly	068212	Relay, Solid State 2A 24VDC Coil Cage Clamp Base	1	+L1.L4/12.1203
K107	Bed Ext Pwr Taper Fwd/Rev Blocking Rly	068212	Relay, Solid State 2A 24VDC Coil Cage Clamp Base	1	+L1.L4/12.1205
K108	Bed Ext Loader Up/Dn Diverter Relay	068212	Relay, Solid State 2A 24VDC Coil Cage Clamp Base	1	+L1.L4/12.1206
K109	Bed Ext Loader Up/Dn Blocking Relay	068212	Relay, Solid State 2A 24VDC Coil Cage Clamp Base	1	+L1.L4/12.1208
K110	Bed Ext Log Deck Fwd/Rev Diverter Rly	068212	Relay, Solid State 2A 24VDC Coil Cage Clamp Base	1	+L1.L4/12.1209
K111	Bed Ext Log Deck Fwd/Rev Blocking Rly	068212	Relay, Solid State 2A 24VDC Coil Cage Clamp Base	1	+L1.L4/12.1211
K150	Bed Extension Toe #4 Up Solenoid Relay	068212	Relay, Solid State 2A 24VDC Coil Cage Clamp Base	1	+L1.L4/29.2909
K151	Bed Extension Toe #4 Down Solenoid Rly	068212	Relay, Solid State 2A 24VDC Coil Cage Clamp Base	1	+L1.L4/29.2911
K152	Bed Extension Clamp Up Solenoid Relay	068212	Relay, Solid State 2A 24VDC Coil Cage Clamp Base	1	+L1.L4/29.2913
K153	Bed Extension Clamp Down Solenoid Rly	068212	Relay, Solid State 2A 24VDC Coil Cage Clamp Base	1	+L1.L4/29.2915
K154	Bed Extension Clamp In Solenoid Relay	068212	Relay, Solid State 2A 24VDC Coil Cage Clamp Base	1	+L1.L4/30.3002
K155	Bed Extension Clamp Out Solenoid Relay	068212	Relay, Solid State 2A 24VDC Coil Cage Clamp Base	1	+L1.L4/30.3004
LAS1	Laser	068035	Laser, 5mW 532nm 90 Deg Line Z-Laser Grn	1	+L1.L4/8.813
M1	Blade Motor	042301	Motor, 30HP 1800RPM	1	+L1.L3/1.115
M2	Hydraulic Pump Motor	078670	Motor, 15HP 230/460 3PH 60Hz	1	+L1.L3/2.202
M3	Feed Motor	115152	Motor, 5HP 3P 230/460 184TC	1	+L1.L3/2.208
M4	Up/Down Servo Motor	068038	Motor, Servo 100mm IP54 Encoder	1	+L1.L3/2.213
M5	Debarker Motor	050292	Motor, 3/4HP 230/460 3P 1725RPM DB LT60	1	+L1.L3/3.302
M6	Blade Guide Motor	035659	Motor Assy, 24V 60 RPM Gear	1	+L1.L4/7.716
MCR1	Master Control Relay	051322	Contact, 25A 3P 24VDC Coil	1	+L1.L4/16.1616
N2	HMI	078794	HMI Assy, Ind. Mill	1	+L5.L7/35.3501
N3	Hydraulic Pwr Unit Proportional Valve Ctrl	068277	Driver Assy, Prop Valve 8 Pin A2.00+	1	+L1.L4/33.3306
OL2	Hydraulic Pump Motor Overload	069885	Overload, 16-24A Class 10 Single Ph Sens	1	+L1.L3/2.202
PB1	E-Stop	068940	Pushbutton Head, 22mm E-Stop Twist-Pull	1	+L1.L4/16.1610
PB1	=	068950	Collar, Mount 1NC ZB5	1	+L1.L4/16.1610
PB1	=	068921	Contact Block, NC ZB5	1	+L1.L4/16.1610
PB2	Blade Brake Manual Override Push-Button	068950	Collar, Mount 1NC ZB5	1	+L1.L4/8.807
PB2	=	068920	Contact Block, NO ZB5	1	+L1.L4/8.807
PBL1	Control Power On PB	068952	Collar, Mount 1NO ZB5	1	+L1.L4/16.1610
PBL1	=	052503	Switch Head, PB Green Flush Illum ZB5	1	+L1.L4/16.1610



Wood-Mizer®

Project Description: WM4500

Revision:	A1.00	Pg Desc:	Parts list
Mounting Location:	+Docs	Type:	Parts list
Prev. pg:	C1	Page:	C2
Next pg:	C3	Total Pgs:	78

Device Tag/Parts List

Device tag	Function	Wood-Mizer Part Number	Wood-Mizer Description	Qty.	X-Ref
PBL1	Control Power On PB	068910	Light Module, Green ZB5	1	+L1.L4/16.1610
PL1	Head Mode Indicator	068912	Light Module, White ZB5	1	+L1.L4/25.2502
PL1	=	068931	Pilot Light, Yellow ZB5	1	+L1.L4/25.2502
PL1	=	068951	Switch Collar, Mount ZB5	1	+L1.L4/25.2502
PL2	Bed Mode Indicator	068912	Light Module, White ZB5	1	+L1.L4/25.2504
PL2	=	068931	Pilot Light, Yellow ZB5	1	+L1.L4/25.2504
PL2	=	068951	Switch Collar, Mount ZB5	1	+L1.L4/25.2504
PLC1	PLC	078783	PLC Assy, Ind. Mill M251	1	+L1.L4/20.2001
PLC1	=	078782	PLC Assy, Ind. Mill CPU	1	+L1.L4/20.2001
PLC1.1	Digital Input	078491	Input Module, Spring Clamp 16Pt Digital	1	+L1.L4/21.2102
PLC1.2	=	078491	Input Module, Spring Clamp 16Pt Digital	1	+L1.L4/23.2302
PLC1.3	Digital Output	078492	Output Module, TM3 16Pt. Transistor	1	+L1.L4/25.2502
PLC1.4	=	078492	Output Module, TM3 16Pt. Transistor	1	+L1.L4/27.2702
PLC1.5	=	078492	Output Module, TM3 16Pt. Transistor	1	+L1.L4/29.2902
PLC1.6	=	078492	Output Module, TM3 16Pt. Transistor	1	+L1.L4/31.3102
PLC1.7	Analog I/O	078648	Analog Module, TM3 4I/2O	1	+L1.L4/33.3302
PRX1	Blade Broken Prox	051439	Sensor, Ind Prox M12 PNP NS Ex	1	+L1.L4/22.2210
PRX2	Ball Nut Prox	051439	Sensor, Ind Prox M12 PNP NS Ex	1	+L1.L4/22.2213
PS1	Blade Tension Pressure Switch	045207	Switch, Limit Pressure 60 PSI	1	+L1.L4/22.2206
PS2	Blade Brake Released Pressure Switch	045207	Switch, Limit Pressure 60 PSI	1	+L1.L4/22.2207
Q1	Main Disconnect	078506	Disconnect, 200A 3Ph Non-Fused	1	+L1.L3/1.101
Q2	Blade Guide Motor Breaker	051915	Breaker, 3A 1P MG24502	1	+L1.L4/7.708
Q3	Lube Pump Motor Breaker	051915	Breaker, 3A 1P MG24502	1	+L1.L4/8.802
Q4	Debarker Motor	068097	Motor Protector, 1.0-1.6 Manual	1	+L1.L3/3.302
Q4	=	068199	Motor Protector, Aux Contacts 1NO 1NC	1	+L1.L3/3.302
Q4	=	068098	Motor Protector, Line Side Barrier	1	+L1.L3/3.302
Q4	=	068099	Motor Protector, Interconnect LC1D09-25	1	+L1.L3/3.302
R1	Feed Drive Braking Resistor	078784	Resistor Assy, Ind. Mill Feed	1	+L1.L3/2.206
R2	Up/Down Drive Bracking Resistor	068161	Resistor Assy, Ind. Mill Up/Dn	1	+L1.L3/2.212
SD1	Up/Down Drive Control	078781	Drive Assy, Ind. Mill Up/Down	1	+L1.L3/2.211
SS2	Key Switch	068950	Collar, Mount 1NC ZB5	1	+L1.L4/21.2104
SS2	=	068920	Contact Block, NO ZB5	1	+L1.L4/21.2104
SS2	=	068941	Switch, Key 3Pos Mom R-C	1	+L1.L4/21.2104
SSD1	Blade Motor Soft Start	069933	Drive Assy, Ind. Mill Blade	1	+L1.L3/1.112
SW1	Seat Switch	069737	Switch, Seat 2 NO Contacts	1	+L1.L4/16.1605
SW2	Auto-Cut Foot Switch	052789	Switch, Foot Single Lever IP68	1	+L1.L4/22.2202
SW3	Secondary Side Supports Foot Switch	052789	Switch, Foot Single Lever IP68	1	+L1.L4/14.1413
T1	Soft-Start Control Transformer	069909	Transformer, 0.05kVA 240x480P 120/240S	1	+L1.L3/3.306
VFD1	Feed Drive Power	078780	Drive Assy, Ind. Mill Feed	1	+L1.L3/2.205
X1.1	1L1 Distribution Block	069908	Distribution Block, 1P 1in 4out 175A DIN	1	+L1.L3/3.305
X1.2	1L3 Distribution Block	069908	Distribution Block, 1P 1in 4out 175A DIN	1	+L1.L3/3.305
X1.3	2L1 Distribution Block	069801	Distribution Block, 1P 1in 6out 380A DIN	1	+L1.L3/1.107
X1.4	2L2 Distribution Block	069801	Distribution Block, 1P 1in 6out 380A DIN	1	+L1.L3/1.107
X1.5	2L3 Distribution Block	069801	Distribution Block, 1P 1in 6out 380A DIN	1	+L1.L3/1.107
X1.6	1L1 Distribution Block	069872	Distribution Block, 1P 2in 2out 620A DIN	1	+L1.L3/1.101
X1.7	1L3 Distribution Block	069872	Distribution Block, 1P 2in 2out 620A DIN	1	+L1.L3/1.103
X3.1	Ground Distribution Block	025203	Bar, Grounding 14 Circuit W/Lug	1	+L1.L3/1.107
Y50	Lube Solenoid	051432	Valve, Solenoid 1/4 NPT Water NC 2 Way	1	+L1.L4/8.802

Terminal line-up diagram

Wood-Mizer_Terminal_Lineup_Diagram

Terminal strip +L1.L3-X2

Terminal				Jumper		End Plate	Remark	Terminal X-Ref
Ref. Des.	Level	P/N	Description	Diagram	P/N	P/N		
TB1		068106	Terminal Block, 2Pos 4mm Clamp	•				+L4/21.09
TB2		068106	Terminal Block, 2Pos 4mm Clamp	•		068108		+L4/21.09
TB3		068106	Terminal Block, 2Pos 4mm Clamp	●				+L4/21.11
TB4		068106	Terminal Block, 2Pos 4mm Clamp	●		068108		+L4/21.11

 Wood-Mizer®	
Project Description: WM4500	
Revision: A1.00	Pg Desc: Terminal line-up diagram
Mounting Location: +Docs	Type: Terminal line-up diagram
Prev. pg: C3	Page: D1
Next pg: D2	Total Pgs: 78

Terminal line-up diagram

Wood-Mizer_Terminal_Lineup_Diagram

Terminal strip +L1.L4-X4

Terminal				Jumper		End Plate	Remark	Terminal X-Ref
Ref. Des.	Level	P/N	Description	Diagram	P/N	P/N		
TB1		068104	Terminal Block, 4Pos 1.5mm GND Clamp	•				+L3/1.05
TB2		068104	Terminal Block, 4Pos 1.5mm GND Clamp	•				+L3/1.05
TB3		068104	Terminal Block, 4Pos 1.5mm GND Clamp	•		068105		+L9/36.09
TB4		068103	Terminal Block, 4Pos 1.5mm Com Clamp	•	068113		Jumper is Trimmed Down To 3 Position Jumper Between TB4-6	+L3/3.12
TB5		068103	Terminal Block, 4Pos 1.5mm Com Clamp	•				/12.12
TB6		068103	Terminal Block, 4Pos 1.5mm Com Clamp	•		068105		+L9/36.08
TB7		068103	Terminal Block, 4Pos 1.5mm Com Clamp	•		068105		+L3/3.11
TB8		068103	Terminal Block, 4Pos 1.5mm Com Clamp	•	068113		Jumper is Trimmed Down To 2 Position Jumper Between TB8-9	/7.06
TB9		068103	Terminal Block, 4Pos 1.5mm Com Clamp	•		068105		/15.02
TB10		068103	Terminal Block, 4Pos 1.5mm Com Clamp	•	068113		Jumper is Trimmed Down To 8 Position Between TB10-17	+L3/3.17
TB11		068103	Terminal Block, 4Pos 1.5mm Com Clamp	•				/25.15
TB12		068103	Terminal Block, 4Pos 1.5mm Com Clamp	•				/29.06
TB13		068103	Terminal Block, 4Pos 1.5mm Com Clamp	•				/15.07
TB14		068103	Terminal Block, 4Pos 1.5mm Com Clamp	•				+L3/6.06
TB15		068103	Terminal Block, 4Pos 1.5mm Com Clamp	•				/25.06
TB16		068103	Terminal Block, 4Pos 1.5mm Com Clamp	•				/7
TB17		068103	Terminal Block, 4Pos 1.5mm Com Clamp	•		068105		/7
TB18		068103	Terminal Block, 4Pos 1.5mm Com Clamp	•	068113		Jumper is Trimmed Down To 4 Position Between TB18-21	+L3/3.16
TB19		068103	Terminal Block, 4Pos 1.5mm Com Clamp	•				/7.03
TB20		068103	Terminal Block, 4Pos 1.5mm Com Clamp	•				/20.02
TB21		068103	Terminal Block, 4Pos 1.5mm Com Clamp	•		068105		+L3/6.05
TB22		068103	Terminal Block, 4Pos 1.5mm Com Clamp	•		068105		+L3/6.02



Wood-Mizer®

Project Description: WM4500

Revision:	A1.00	Pg Desc:	Terminal line-up diagram
Mounting Location:	+Docs	Type:	Terminal line-up diagram
Prev. pg:	D1	Page:	D2
Next pg:	D3	Total Pgs:	78

Terminal line-up diagram

Wood-Mizer_Terminal_Lineup_Diagram

Terminal strip +L5.L6-X5

Terminal				Jumper		End Plate	Remark	Terminal X-Ref
Ref. Des.	Level	P/N	Description	Diagram	P/N	P/N		
TB1		068104	Terminal Block, 4Pos 1.5mm GND Clamp	⋮		068105		+L7/35.08
TB2		068103	Terminal Block, 4Pos 1.5mm Com Clamp	●	068113		Jumper is Trimmed Down To 2 Position Between TB2-3	+L7/35.07
TB3		068103	Terminal Block, 4Pos 1.5mm Com Clamp	●		068105		+L1.L4/14.19
TB4		068103	Terminal Block, 4Pos 1.5mm Com Clamp	●	068113		Jumper is Trimmed Down To 2 Position Between TB4-5	+L1.L4/22.02
TB5		068103	Terminal Block, 4Pos 1.5mm Com Clamp	●		068105		+L7/35.06
TB6	1	068119	Terminal Block, 2 Tier 2.5mm Clamp	⋮		068120		+L1.L4/16.05
TB6	2			⋮				+L1.L4/16.05
TB7	1	068119	Terminal Block, 2 Tier 2.5mm Clamp	⋮				+L7/35.07
TB7	2			⋮				+L7/35.08
TB8	1	068119	Terminal Block, 2 Tier 2.5mm Clamp	⋮				+L1.L4/16.07
TB8	2			⋮				+L7/35.06
TB9	1	068119	Terminal Block, 2 Tier 2.5mm Clamp	⋮				+L1.L4/16.13
TB9	2			⋮				+L1.L4/16.13
TB10	1	068119	Terminal Block, 2 Tier 2.5mm Clamp	⋮				+L1.L4/21.06
TB10	2			⋮				+L1.L4/21.04
TB11	1	068119	Terminal Block, 2 Tier 2.5mm Clamp	⋮		068120		+L1.L4/17.02
TB11	2			⋮				
TB12	1	068119	Terminal Block, 2 Tier 2.5mm Clamp	⋮				+L1.L4/23.03
TB12	2			⋮				+L1.L4/23.03
TB13	1	068119	Terminal Block, 2 Tier 2.5mm Clamp	●				+L1.L4/23.04
TB13	2			●				+L1.L4/23.04
TB14	1	068119	Terminal Block, 2 Tier 2.5mm Clamp	⋮				+L1.L4/23.06
TB14	2			⋮				+L1.L4/23.05
TB15	1	068119	Terminal Block, 2 Tier 2.5mm Clamp	⋮				+L1.L4/23.08
TB15	2			⋮				+L1.L4/23.06
TB16	1	068119	Terminal Block, 2 Tier 2.5mm Clamp	⋮				+L1.L4/23.08
TB16	2			⋮				+L1.L4/23.09
TB17	1	068119	Terminal Block, 2 Tier 2.5mm Clamp	⋮		068120		+L1.L4/23.07
TB17	2			⋮				+L1.L4/23.09
TB18	1	068119	Terminal Block, 2 Tier 2.5mm Clamp	⋮				+L1.L4/24.03
TB18	2			⋮				+L1.L4/24.03
TB19	1	068119	Terminal Block, 2 Tier 2.5mm Clamp	⋮				+L1.L4/24.04
TB19	2			⋮				+L1.L4/24.04
TB20	1	068119	Terminal Block, 2 Tier 2.5mm Clamp	⋮				+L1.L4/24.06
TB20	2			⋮				+L1.L4/24.05



Wood-Mizer®

Project Description: WM4500

Revision:	A1.00	Pg Desc:	Terminal line-up diagram
Mounting Location:	+Docs	Type:	Terminal line-up diagram
Prev. pg:	D2	Page:	D3
Next pg:	D4	Total Pgs:	78

Terminal line-up diagram

Wood-Mizer_Terminal_Lineup_Diagram

Terminal strip +L5.L6-X5

Terminal				Jumper		End Plate	Remark	Terminal X-Ref
Ref. Des.	Level	P/N	Description	Diagram	P/N	P/N		
TB21	1	068119	Terminal Block, 2 Tier 2.5mm Clamp	•				+L1.L4/24.08
TB21	2			•				+L1.L4/24.06
TB22	1	068119	Terminal Block, 2 Tier 2.5mm Clamp	•				+L1.L4/24.08
TB22	2			•				+L1.L4/24.09
TB23	1	068119	Terminal Block, 2 Tier 2.5mm Clamp	•		068120		+L1.L4/24.07
TB23	2			•				+L1.L4/24.09
TB24	1	068119	Terminal Block, 2 Tier 2.5mm Clamp	•				+L1.L4/22.02
TB24	2			•				+L1.L4/22.02
TB25	1	068119	Terminal Block, 2 Tier 2.5mm Clamp	•		068120		
TB25	2			•				+L1.L4/22.03
TB26	1	068119	Terminal Block, 2 Tier 2.5mm Clamp	•				+L1.L4/16.07
TB26	2			•				+L1.L4/16.07
TB27	1	068119	Terminal Block, 2 Tier 2.5mm Clamp	•				+L1.L4/16.07
TB27	2			•				+L1.L4/16.07
TB28	1	068119	Terminal Block, 2 Tier 2.5mm Clamp	•				+L1.L4/16.07
TB28	2			•				+L1.L4/16.07
TB29	1	068119	Terminal Block, 2 Tier 2.5mm Clamp	•		068120		+L1.L4/17.04
TB29	2			•				+L1.L4/17.03
TB30	1	068119	Terminal Block, 2 Tier 2.5mm Clamp	•		068120		+L1.L4/17
TB30	2			•				+L1.L4/17.05
TB31	1	068119	Terminal Block, 2 Tier 2.5mm Clamp	•				+L1.L4/14.19
TB31	2			•				+L1.L4/14.20
TB32	1	068119	Terminal Block, 2 Tier 2.5mm Clamp	•		068120		+L1.L4/14.18
TB32	2			•				



Wood-Mizer®

Project Description: WM4500

Revision:	A1.00	Pg Desc:	Terminal line-up diagram
Mounting Location:	+Docs	Type:	Terminal line-up diagram
Prev. pg:	D3	Page:	D4
Next pg:	D5	Total Pgs:	78

Terminal line-up diagram

Wood-Mizer_Terminal_Lineup_Diagram

Terminal strip +L11.L12-X6

Terminal				Jumper		End Plate	Remark	Terminal X-Ref
Ref. Des.	Level	P/N	Description	Diagram	P/N	P/N		
TB1		068104	Terminal Block, 4Pos 1.5mm GND Clamp	•				+L1.L3/1.08
TB2		068104	Terminal Block, 4Pos 1.5mm GND Clamp	•		068105		+L1.L4/18.12
TB3		068103	Terminal Block, 4Pos 1.5mm Com Clamp	•	068113		Jumper is Trimmed Down To 2 Position Between TB3-4	+L1.L4/8.05
TB4		068103	Terminal Block, 4Pos 1.5mm Com Clamp	•		068105		+L1.L4/8.13
TB5		068103	Terminal Block, 4Pos 1.5mm Com Clamp	•	068113		Jumper is Trimmed Down To 3 Position Between TB5-7	+L1.L4/15.09
TB6		068103	Terminal Block, 4Pos 1.5mm Com Clamp	•				+L1.L4/25.02
TB7		068103	Terminal Block, 4Pos 1.5mm Com Clamp	•		068105		+L1.L4/18.12
TB8		068103	Terminal Block, 4Pos 1.5mm Com Clamp	•	068113		Jumper is Trimmed Down To 2 Position Between TB8-9	+L1.L4/22.07
TB9		068103	Terminal Block, 4Pos 1.5mm Com Clamp	•		068105		+L1.L4/22.06
TB10	1	068119	Terminal Block, 2 Tier 2.5mm Clamp	•				+L1.L4/16.02
TB10	2			•				+L1.L4/16.02
TB11	1	068119	Terminal Block, 2 Tier 2.5mm Clamp	•				+L1.L4/16.02
TB11	2			•				+L1.L4/16.02
TB12	1	068119	Terminal Block, 2 Tier 2.5mm Clamp	•				+L1.L4/7.15
TB12	2			•				+L1.L4/7.17
TB13	1	068119	Terminal Block, 2 Tier 2.5mm Clamp	•				+L1.L4/8.09
TB13	2			•				+L1.L4/8.07
TB14	1	068119	Terminal Block, 2 Tier 2.5mm Clamp	•				
TB14	2			•				+L1.L4/8.11
TB15	1	068119	Terminal Block, 2 Tier 2.5mm Clamp	•				
TB15	2			•				+L1.L4/8.13
TB16	1	068119	Terminal Block, 2 Tier 2.5mm Clamp	•		068120		+L1.L4/22.13
TB16	2			•				+L1.L4/22.10
TB17	1	068119	Terminal Block, 2 Tier 2.5mm Clamp	•				+L1.L4/8
TB17	2			•				+L1.L4/8.16



Wood-Mizer®

Project Description: WM4500

Revision:	A1.00	Pg Desc:	Terminal line-up diagram
Mounting Location:	+Docs	Type:	Terminal line-up diagram
Prev. pg:	D4	Page:	D5
Next pg:	D6	Total Pgs:	78

Terminal line-up diagram

Wood-Mizer_Terminal_Lineup_Diagram

Terminal strip +L9.L10-X7

Terminal				Jumper		End Plate	Remark	Terminal X-Ref
Ref. Des.	Level	P/N	Description	Diagram	P/N	P/N		
TB1		068104	Terminal Block, 4Pos 1.5mm GND Clamp	•				+L1.L3/1.08
TB2		068104	Terminal Block, 4Pos 1.5mm GND Clamp	•				+L1.L4/9.03
TB3		068104	Terminal Block, 4Pos 1.5mm GND Clamp	•				+L1.L4/9.07
TB4		068104	Terminal Block, 4Pos 1.5mm GND Clamp	•				+L1.L4/9.10
TB5		068104	Terminal Block, 4Pos 1.5mm GND Clamp	•		068105		+L1.L4/14.03
TB6		068103	Terminal Block, 4Pos 1.5mm Com Clamp	•	068113		Jumper is Trimmed Down To 5 Position Between TB6-10	+L1.L4/9.01
TB7		068103	Terminal Block, 4Pos 1.5mm Com Clamp	•				+L1.L4/9.02
TB8		068103	Terminal Block, 4Pos 1.5mm Com Clamp	•				+L1.L4/9.06
TB9		068103	Terminal Block, 4Pos 1.5mm Com Clamp	•				+L1.L4/9.09
TB10		068103	Terminal Block, 4Pos 1.5mm Com Clamp	•				068105
TB11		068103	Terminal Block, 4Pos 1.5mm Com Clamp	•		068105	+L1.L4/15.11	
TB12		068103	Terminal Block, 4Pos 1.5mm Com Clamp	•		068105	+L1.L4/15.11	
TB13	1	068119	Terminal Block, 2 Tier 2.5mm Clamp	•				+L1.L4/9.02
TB13	2			•				+L1.L4/9.04
TB14	1	068119	Terminal Block, 2 Tier 2.5mm Clamp	•				+L1.L4/9.06
TB14	2			•				+L1.L4/9.08
TB15	1	068119	Terminal Block, 2 Tier 2.5mm Clamp	•				+L1.L4/9.09
TB15	2			•				+L1.L4/9.11
TB16	1	068119	Terminal Block, 2 Tier 2.5mm Clamp	•				+L1.L4/9.13
TB16	2			•				+L1.L4/9.15
TB17	1	068119	Terminal Block, 2 Tier 2.5mm Clamp	•				+L1.L4/9.16
TB17	2			•				+L1.L4/9.19
TB18	1	068119	Terminal Block, 2 Tier 2.5mm Clamp	•				+L1.L4/10.02
TB18	2			•				+L1.L4/10.04
TB19	1	068119	Terminal Block, 2 Tier 2.5mm Clamp	•				+L1.L4/10.05
TB19	2			•				+L1.L4/10.07
TB20	1	068119	Terminal Block, 2 Tier 2.5mm Clamp	•				+L1.L4/10.09
TB20	2			•				+L1.L4/10.11
TB21	1	068119	Terminal Block, 2 Tier 2.5mm Clamp	•				+L1.L4/10.12
TB21	2			•				
TB22	1	068119	Terminal Block, 2 Tier 2.5mm Clamp	•				+L1.L4/10.14
TB22	2			•				+L1.L4/10.16
TB23	1	068119	Terminal Block, 2 Tier 2.5mm Clamp	•				+L1.L4/11.02
TB23	2			•				+L1.L4/11.04
TB24	1	068119	Terminal Block, 2 Tier 2.5mm Clamp	•				+L1.L4/11.05



Wood-Mizer®

Project Description: WM4500

Revision:	A1.00	Pg Desc:	Terminal line-up diagram
Mounting Location:	+Docs	Type:	Terminal line-up diagram
Prev. pg:	D5	Page:	D6
Next pg:	D7	Total Pgs:	78

Terminal line-up diagram

Wood-Mizer_Terminal_Lineup_Diagram

Terminal strip +L9.L10-X7

Terminal				Jumper		End Plate	Remark	Terminal X-Ref
Ref. Des.	Level	P/N	Description	Diagram	P/N	P/N		
TB24	2			•				+L1.L4/11.07
TB25	1	068119	Terminal Block, 2 Tier 2.5mm Clamp	•				+L1.L4/33.07
TB25	2			•				+L1.L4/33.08
TB26	1	068119	Terminal Block, 2 Tier 2.5mm Clamp	•				+L1.L4/11.09
TB26	2			•				
TB27	1	068119	Terminal Block, 2 Tier 2.5mm Clamp	•				+L1.L4/14.02
TB27	2			•				+L1.L4/14.04
TB28	1	068119	Terminal Block, 2 Tier 2.5mm Clamp	•				+L1.L4/14.05
TB28	2			•				+L1.L4/14.07
TB29	1	068119	Terminal Block, 2 Tier 2.5mm Clamp	•		068102		+L1.L4/14.09
TB29	2			•				+L1.L4/14.11



Wood-Mizer®

Project Description: WM4500

Revision: A1.00 Pg Desc: Terminal line-up diagram

Mounting Location: +Docs Type: Terminal line-up diagram

Prev. pg: D6 Page: D7 Next pg: D8 Total Pgs: 78

Terminal line-up diagram

Wood-Mizer_Terminal_Lineup_Diagram

Terminal strip +L5.L14-X8

Terminal				Jumper		End Plate	Remark	Terminal X-Ref
Ref. Des.	Level	P/N	Description	Diagram	P/N	P/N		
TB1		068104	Terminal Block, 4Pos 1.5mm GND Clamp	•				+L1.L3/1.08
TB2		068104	Terminal Block, 4Pos 1.5mm GND Clamp	•				+L1.L4/12.14
TB3		068104	Terminal Block, 4Pos 1.5mm GND Clamp	•				+L1.L4/12.16
TB4		068104	Terminal Block, 4Pos 1.5mm GND Clamp	•		068105		+L1.L4/12.18
TB5		068103	Terminal Block, 4Pos 1.5mm Com Clamp	●	068113		Jumper is Trimmed Down To 4 Position Between TB5-8	+L1.L4/11.12
TB6		068103	Terminal Block, 4Pos 1.5mm Com Clamp	●				+L1.L4/11.13
TB7		068103	Terminal Block, 4Pos 1.5mm Com Clamp	●				+L1.L4/12.13
TB8		068103	Terminal Block, 4Pos 1.5mm Com Clamp	●		068105		+L1.L4/12.15



Wood-Mizer®

Project Description: WM4500

Revision: A1.00 Pg Desc: Terminal line-up diagram

Mounting Location: +Docs Type: Terminal line-up diagram

Prev. pg: D7 Page: D8 Next pg: D9 Total Pgs: 78

Terminal line-up diagram

Wood-Mizer_Terminal_Lineup_Diagram

Terminal strip +L5.L15-X9

Terminal				Jumper		End Plate	Remark	Terminal X-Ref
Ref. Des.	Level	P/N	Description	Diagram	P/N	P/N		
TB1		052293	Junction Block, 3-Position Wire Clamp	•				+L1.L4/14.15
TB2		052293-2	Junction Block, 2-Position Wire Clamp	•				+L1.L4/14.14
TB3		052293-2	Junction Block, 2-Position Wire Clamp	•				+L1.L4/14.13
TB4		052293	Junction Block, 3-Position Wire Clamp	•				+L1.L4/14.14

		Wood-Mizer®	
Project Description: WM4500			
Revision:	A1.00	Pg Desc: Terminal line-up diagram	
Mounting Location: +Docs		Type: Terminal line-up diagram	
Prev. pg:	D8	Page:	D9
Next pg:	E1	Total Pgs:	78

Cable Overview

Wood-Mizer_Cable_Overview

Cable Designation	Cable Part Number	Cable Description	Cable X-Ref
W1	069958	Cable Assy, Ind. Mill Blade Motor	+L1.L3/1.118
W2	069993	Cable Assy, Ind. Mill Hydraulic Mtr	+L1.L3/2.202
W3	078441	Cable Assy, Ind. Mill Feed Motor	+L1.L3/2.208
W4	068179	Cable Assy, Ind. Mill Up/Dn Servo Mtr	+L1.L3/2.214
W5	068180	Cable Assy, Ind. Mill Up/Dn Servo Enc	+L1.L3/2.213
W6	069959	Cable Assy, Ind. Mill Debarker Motor	+L1.L3/3.302
W20	069962	Cable Assy, Ind. Mill Head Box	+L1.L4/7.708
W21	078656	Cable Assy, Ind. Mill Hydraulic Control	+L1.L4/10.1002
W22	078657	Cable Assy, Ind. Mill Operator Junction	+L1.L4/15.1514
W23	078658	Cable Assy, Ind. Mill HMI Control	+L1.L4/16.1610
W30	078659	Cable Assy, Ind. Mill Left Joystick	+L1.L4/23.2303
W31	078660	Cable Assy, Ind. Mill Right Joystick	+L1.L4/24.2403
W32	078054	Cable Assy, Ind. Mill Sec. Side Supports	+L1.L4/14.1418
W33	078053	Cable Assy, Ind. Mill Sd Spt Ft Pdl	+L1.L4/14.1413
W34	069963	Cable Assy, Ind. Mill Seat Switch	+L1.L4/16.1605
W35	078661	Cable Assy, Ind. Mill Foot Pedal	+L1.L4/22.2202
W36	078662	Cable Assy, Ind. Mill Blade Break Prox	+L1.L4/22.2210
W37	078663	Cable Assy, Ind. Mill Ball Nut Prox	+L1.L4/22.2212
W38	069988	Cable Assy, Ind. Mill Blade Guide Motor	+L1.L4/7.715
W39	068074	Cable Assy, Ind. Mill Laser	+L1.L4/8.813
W40	068048	Cable Assy, Ind. Mill Feed Encoder Pwr	+L1.L4/18.1811
W40A	068206	Connector Assy, Ind. Mill Feed Encoder	+L1.L4/18.1811
W41	078791	Cable Assy, Drag Back Solenoid	+L1.L4/8.802
W42	078665	Cable Assy, Ind. Mill Prop Valve	+L1.L4/33.3307
W61	069977	Cable Assy, Ind. Mill Bld Brk Sol.	+L1.L4/8.807
W62	069978	Cable Assy, Ind. Mill Blw Off Sol.	+L1.L4/8.809
W63	069979	Cable Assy, Ind. Mill Debarker Sol.	+L1.L4/8.811
W64	069966	Cable Assy, Ind. Mill Clamp In/Out Sol	+L1.L4/9.902
W65	069967	Cable Assy, Ind. Mill Turner Up/Dn Sol.	+L1.L4/9.906
W66	069968	Cable Assy, Ind. Mill Clamp Up/Dn Sol.	+L1.L4/9.909
W67	069969	Cable Assy, Ind. Mill Toe #1 Up/Dn Sol.	+L1.L4/9.913
W68	069970	Cable Assy, Ind. Mill Pwr Tpr Fwd/Rv Sol.	+L1.L4/9.916
W69	069971	Cable Assy, Ind. Mill Toe #2 Up/Dn Sol.	+L1.L4/10.1002
W70	069972	Cable Assy, Ind. Mill Toe #3 Up/Dn Sol.	+L1.L4/10.1005
W71	069973	Cable Assy, Ind. Mill Sd Sup Up/Dn Sol.	+L1.L4/10.1009



Wood-Mizer®

Project Description: WM4500

Revision:	A1.00	Pg Desc:	Cable overview
Mounting Location:	+Docs	Type:	Cable overview
Prev. pg:	D9	Page:	E1
		Next pg:	E2
		Total Pgs:	78

Cable Overview

Wood-Mizer_Cable_Overview

Cable Designation	Cable Part Number	Cable Description	Cable X-Ref
W72	068189	Cable Assy, Ind. Mill Conveyor Sol.	+L1.L4/10.1012
W73	069974	Cable Assy, Ind. Mill Pwr Tpr Fwd/Rv Sol.	+L1.L4/10.1014
W74	069975	Cable Assy, Ind. Mill Loader Up/Dn Sol.	+L1.L4/11.1102
W75	069976	Cable Assy, Ind. Mill Log Deck Fwd/Rev S	+L1.L4/11.1105
W76	068281	Cable Assy, Ind. Mill DumpValve	+L1.L4/11.1109
W77	069978	Cable Assy, Ind. Mill Blw Off Sol.	+L1.L4/8.816
W80	078905	Cable Assy, Pull Down Clamp 1 Up/Down	+L9/37.3702
W81	078906	Cable Assy, Pull Down Clamp 1 In/Out	+L9/37.3711
W82	078907	Cable Assy, Pull Down Clamp 2 Up/Down	+L9/38.3802
W83	078908	Cable Assy, Pull Down Clamp 2 In/Out	+L9/38.3811
W90	078055	Cable Assy, Ind. Mill Sec Sd Spt Sol	+L1.L4/14.1413
W100	069937	Cable Assy, Ind. Mill CANopen PLC	+L1.L4/20.2011
W101	069873	Cable Assy, Ind. Mill CANopen Feed Drive	+L1.L4/18.1802
W102	069874	Cable Assy, Ind. Mill CANopen Up/Dn Driv	+L1.L4/18.1802
W103.A	068029	Connector Assy, Ind. Mill CANopen Main	+L1.L4/18.1808
W103.B	068283	Cable Assy, Ind. Mill Encoder CAN	+L1.L4/18.1808
W104	078897	Cable Assy, Pull Down Clamps Mdl CAN	+L9/36.3611
W120	069923	Cable Assy, Ind. Mill Modbus Soft Start	+L1.L4/20.2006
W130	068162	Cable Assy, Ind. Mill Ethernet PLC	+L1.L4/20.2008
W131.A	069888	Cable Assy, Ind. Mill Ethernet Main Inte	+L1.L4/18.1818
W131.B	069997	Cable Assy, Ind. Mill HMI Ethernet	+L5.L7/35.3510
W131.C	069986	Cable Assy, Ind. Mill Ethernet HMI Int	+L5.L7/35.3510
W140	068178	Receptacle, Panel Mount USB	+L5.L7/35.3508
W150	068291	Cable Assy, Ind. Mill BedX Toe Brd U/D	+L1.L4/14.1402
W151	068292	Cable Assy, Ind. Mill BedX Clamp U/D	+L1.L4/14.1405
W152	068293	Cable Assy, Ind. Mill BedX Clamp In/Out	+L1.L4/14.1409
W200	078895	Connector Assy, Ind. Mill Remote Pwr	+L9/36.3606
W201	078898	Cable Assy, Pull Down Clamps Mdl Pwr	+L9/36.3606
W1000	068247	Cable Assy, Ind. Mill Hyd. Bed Ex	+L1.L4/11.1112
W1001	068248	Cable Assy, Ind. Mill BX Trn FR Div	+L1.L4/12.1213
W1002	068249	Cable Assy, Ind. Mill BX Trn FR Blk	+L1.L4/12.1215
W1003	068274	Cable Assy, Ind. Mill BX SS UD Div	+L1.L4/12.1217
W1004	068275	Cable Assy, Ind. Mill BX SS UD Blk	+L1.L4/13.1302
W1005	068276	Cable Assy, Ind. Mill BX Trn UD Div	+L1.L4/13.1304
W1006	068277	Cable Assy, Ind. Mill BX PT FR Div	+L1.L4/13.1306



Wood-Mizer®

Project Description: WM4500

Revision:	A1.00	Pg Desc:	Cable overview
Mounting Location:	+Docs	Type:	Cable overview
Prev. pg:	E1	Page:	E2
		Next pg:	E3
		Total Pgs:	78

Cable Overview

Wood-Mizer_Cable_Overview

Cable Designation	Cable Part Number	Cable Description	Cable X-Ref
W1007	068278	Cable Assy, Ind. Mill BX PT FR Blk	+L1.L4/13.1308
W1008	068280	Cable Assy, Ind. Mill BX LD UD Div	+L1.L4/13.1310
W1009	068288	Cable Assy, Ind. Mill BX LD UD Blk	+L1.L4/13.1312
W1010	068289	Cable Assy, Ind. Mill BX LD FR Div	+L1.L4/13.1314
W1011	068290	Cable Assy, Ind. Mill BX LD FR Blk	+L1.L4/13.1316
Z1	078785	Harness Assy, Ind. Mill Disconnect	+L1.L3/1.101
Z3	069935	Harness Assy, Ind. Mill Transformer	+L1.L3/3.306

		Wood-Mizer®	
Project Description: WM4500			
Revision:	A1.00	Pg Desc: Cable overview	
Mounting Location: +Docs		Type: Cable overview	
Prev. pg:	E2	Page:	E3
Next pg:	F1	Total Pgs:	78



		Wood-Mizer®	
Project Description: WM4500			
Revision:	A1.00	Pg Desc: Main Control Layout	
Mounting Location:	+Docs	Type: Panel layout	
Prev. pg:	E3	Page:	F1
		Next pg:	F2
		Total Pgs:	78

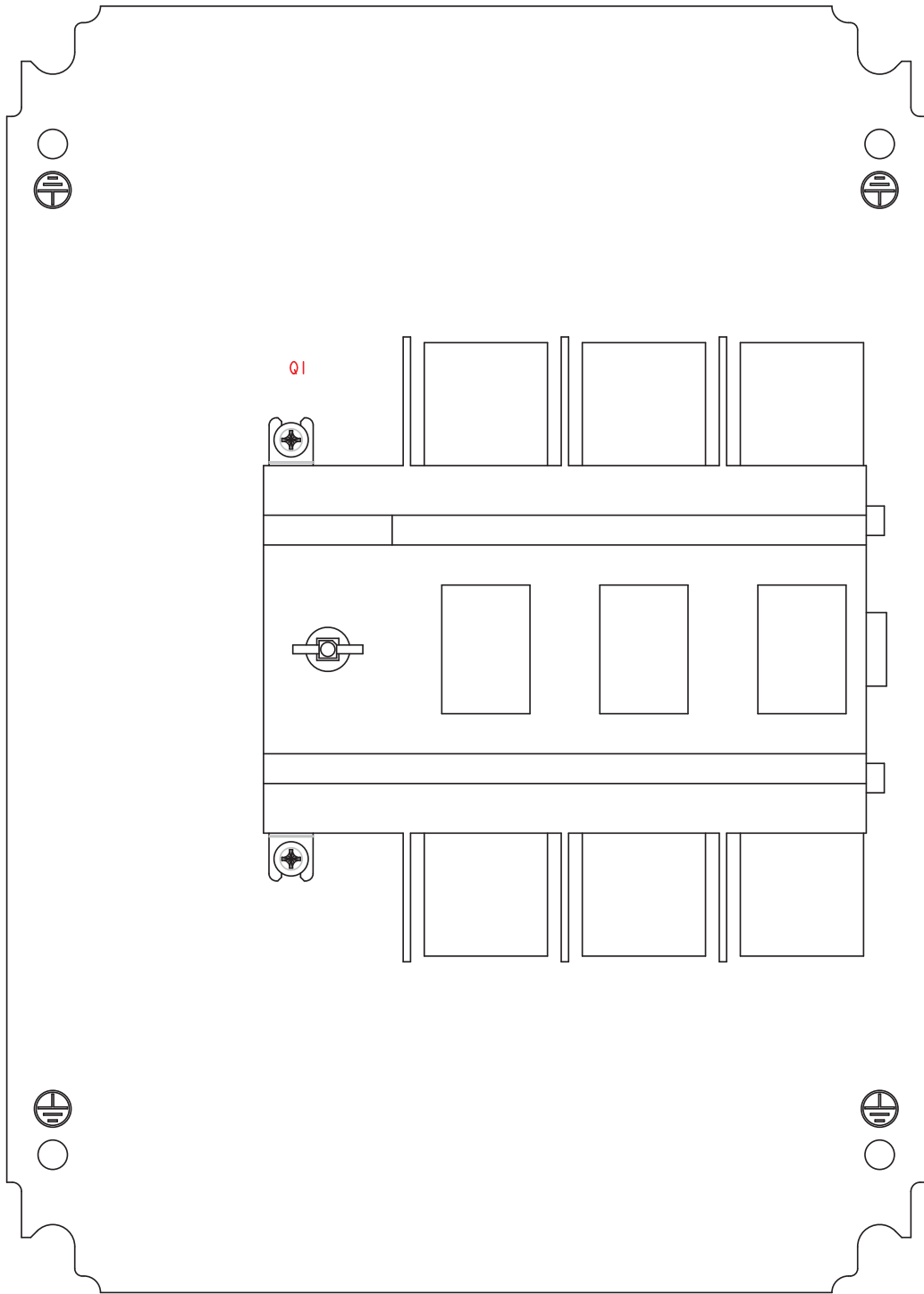

		Wood-Mizer®	
Project Description: WM4500			
Revision:	A1.00	Pg Desc: Main Control Disconnect Layout	
Mounting Location: +Docs		Type: Panel layout	
Prev. pg:	F1	Page:	F2
Next pg:	F3	Total Pgs:	78

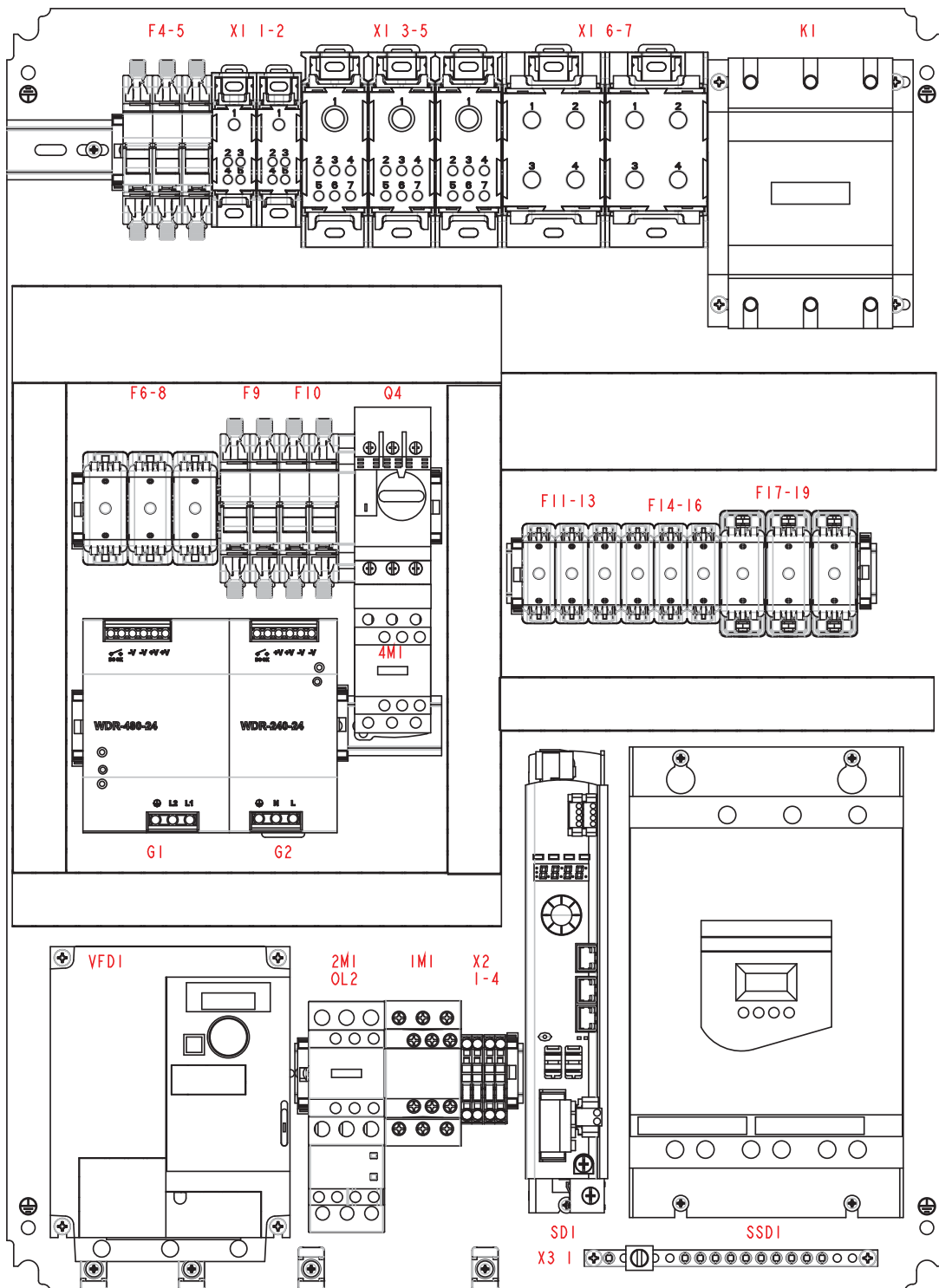

Wood-Mizer®

Project Description: WM4500

Revision:	A1.00	Pg Desc: Main Control High Voltage Layout	
Mounting Location:	+Docs	Type: Panel layout	
Prev. pg:	F2	Page:	F3
		Next pg:	F4
		Total Pgs:	78

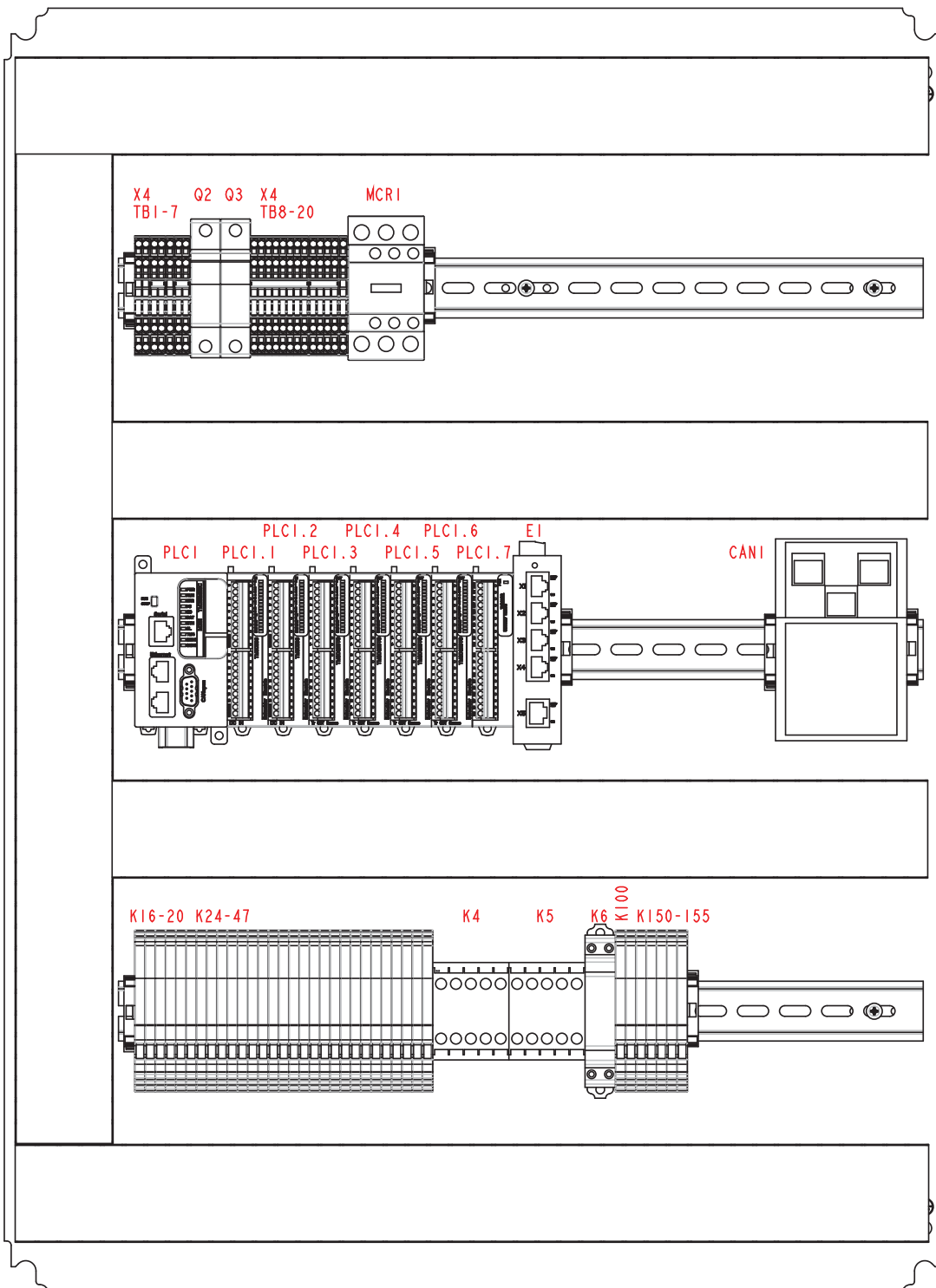

Wood-Mizer®

Project Description: WM4500

Revision:	A1.00	Pg Desc: Main Control Low Voltage Layout	
Mounting Location:	+Docs	Type: Panel layout	
Prev. pg:	F3	Page:	F4
		Next pg:	F5
		Total Pgs:	78

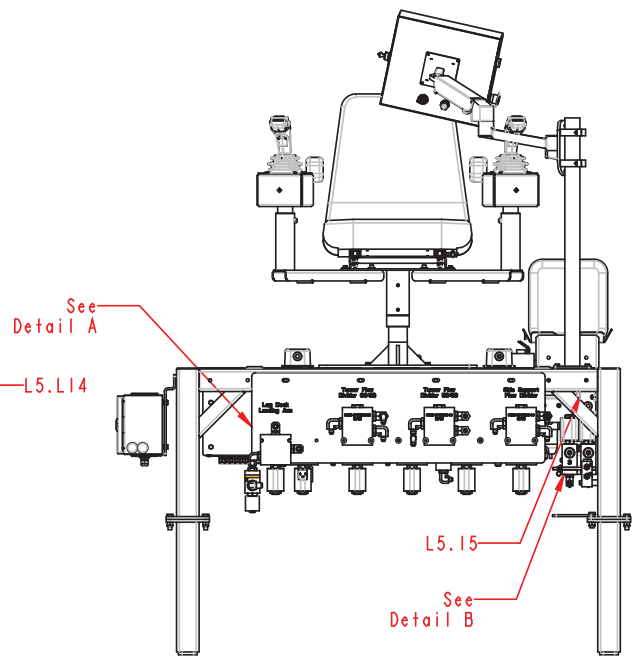
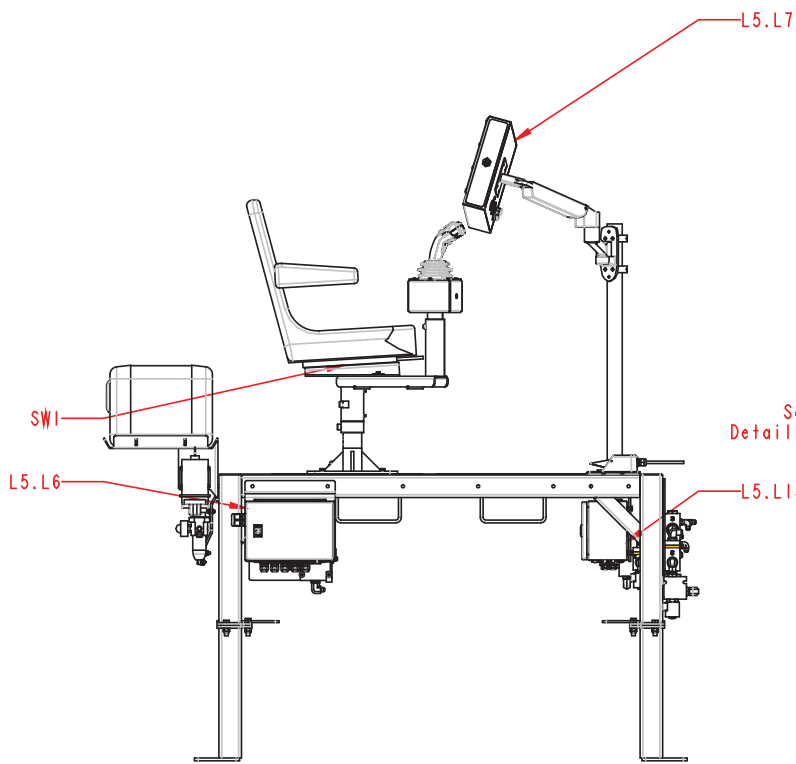
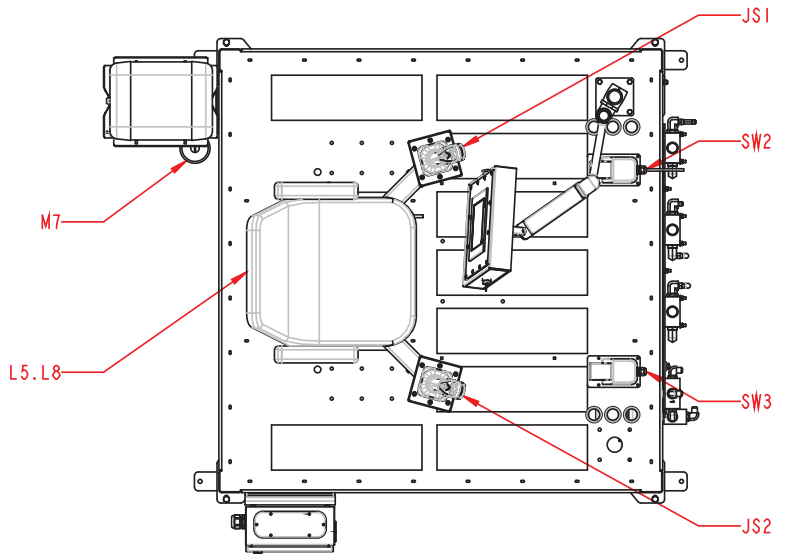

		Wood-Mizer®	
Project Description: WM4500			
Revision:	A1.00	Pg Desc: Operator Ctl Layout	
Mounting Location:	+Docs	Type: Panel layout	
Prev. pg:	F4	Page:	F5
		Next pg:	F6
		Total Pgs:	78

Detail A
FRONT

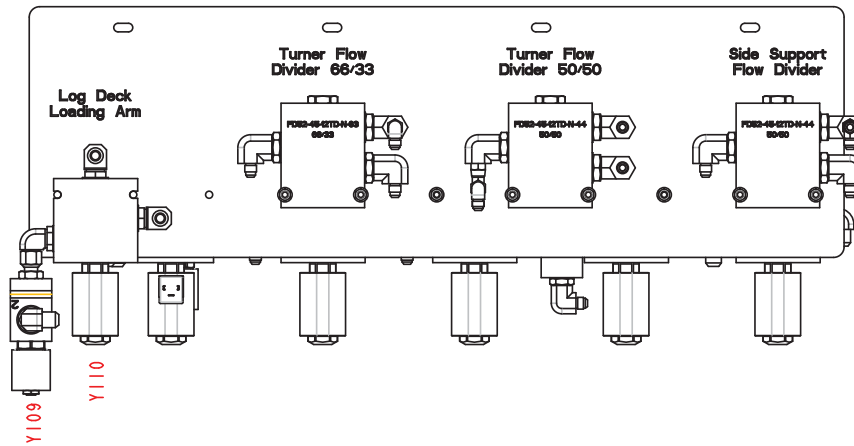

Detail A
BACK

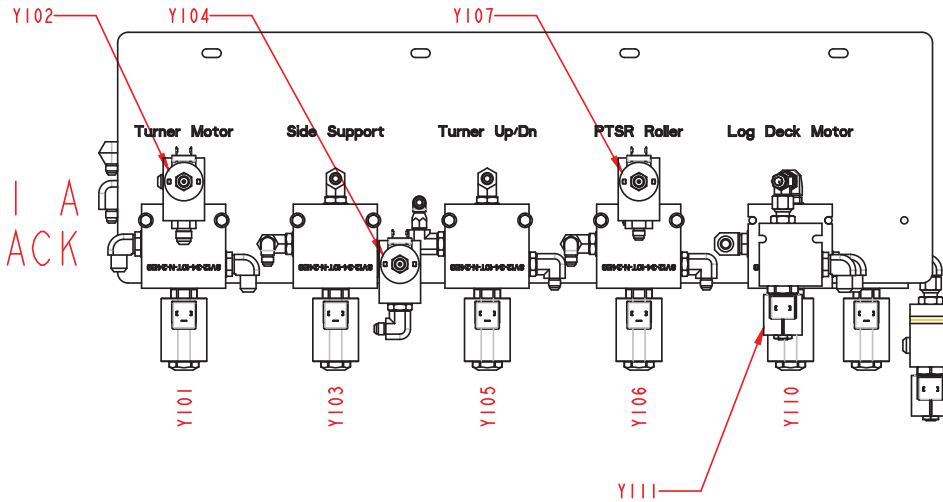

Detail B

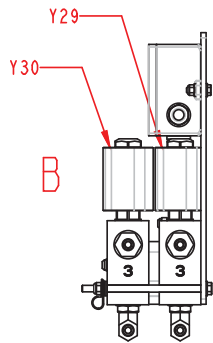

		Wood-Mizer®	
Project Description: WM4500			
Revision:	A1.00	Pg Desc: Operator Ctl Solenoid Layout	
Mounting Location: +Docs		Type: Panel layout	
Prev. pg:	F5	Page:	F6
Next pg:		F7	Total Pgs: 78

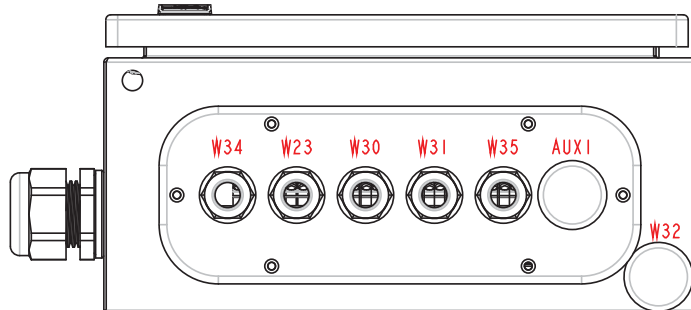
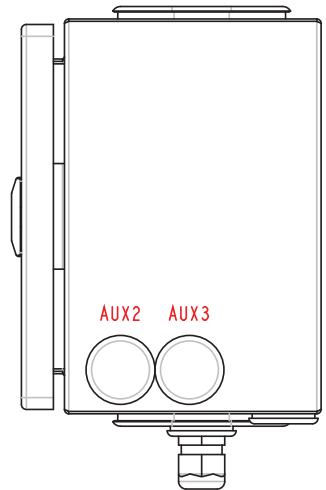
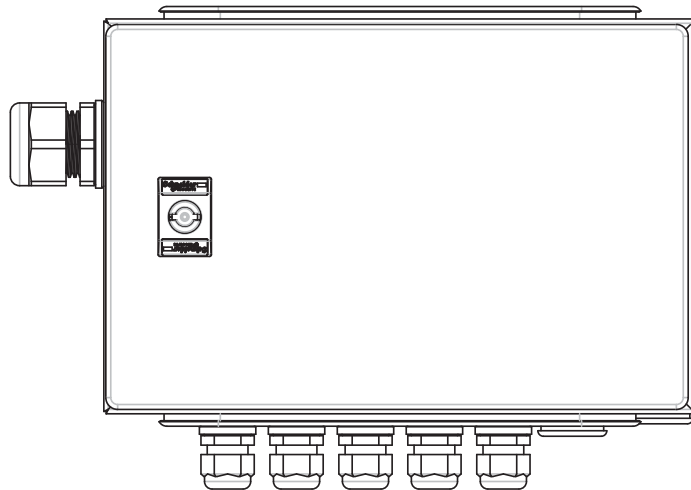
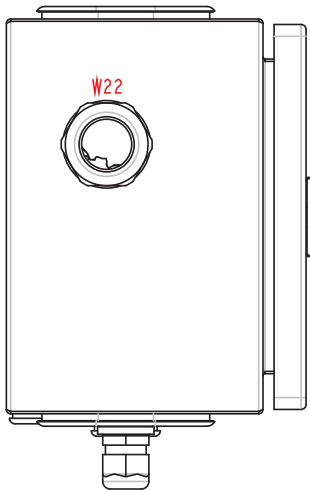
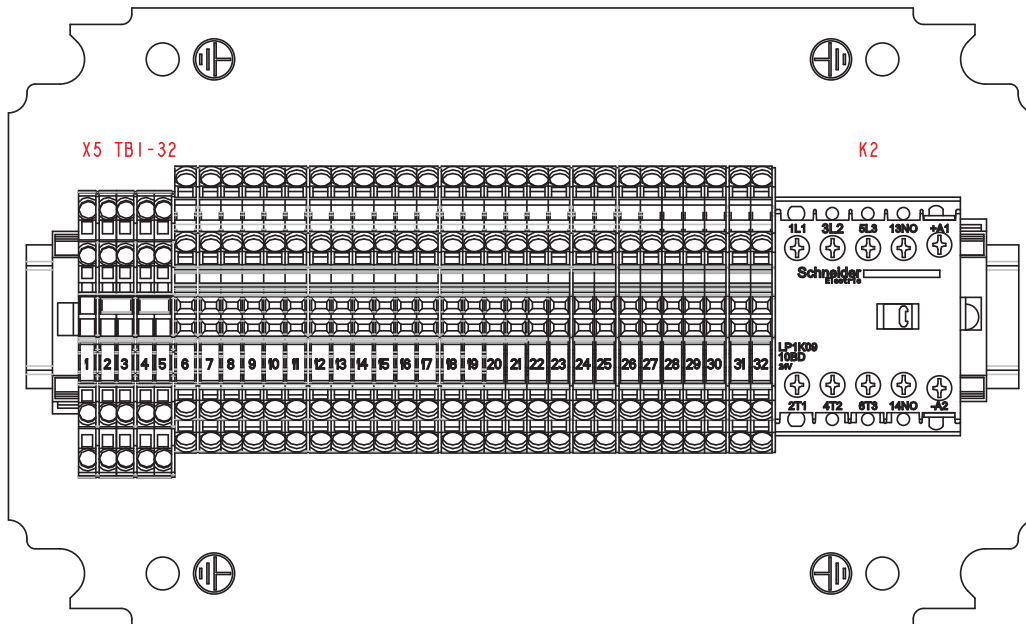

		Wood-Mizer®	
Project Description: WM4500			
Revision:	A1.00	Pg Desc: Operator Ctl Junction Layout	
Mounting Location:	+Docs	Type: Panel layout	
Prev. pg:	F6	Page:	F7
		Next pg:	F8
		Total Pgs:	78

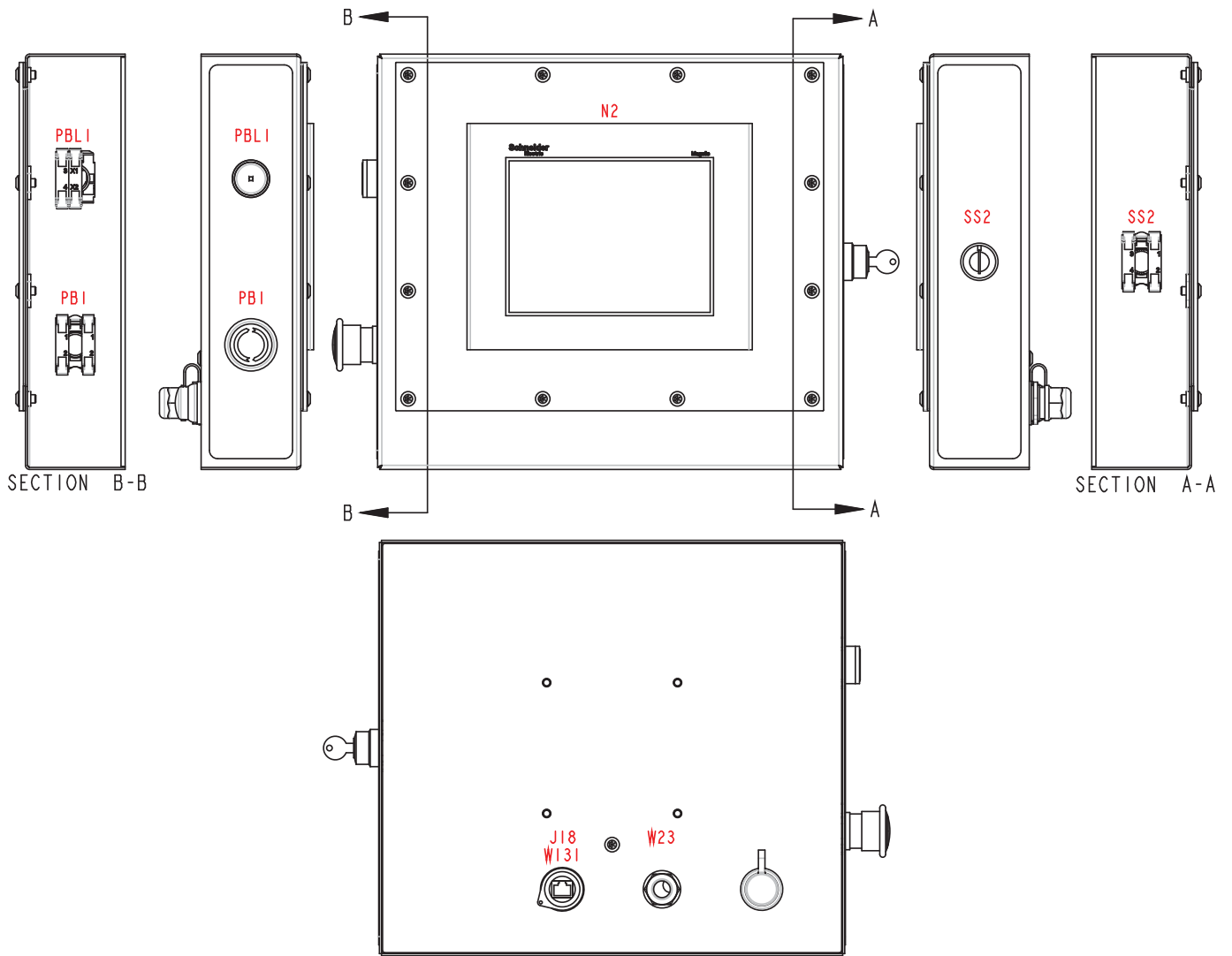

		Wood-Mizer®	
Project Description: WM4500			
Revision:	A1.00	Pg Desc: Operator Ctl HMI Layout	
Mounting Location: +Docs		Type: Panel layout	
Prev. pg:	F7	Page:	F8
Next pg:	F9	Total Pgs:	78

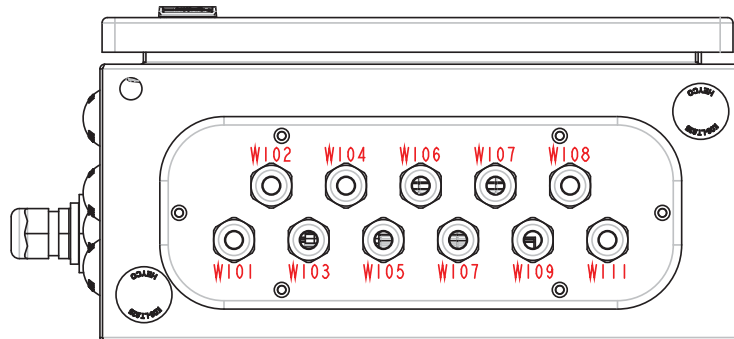
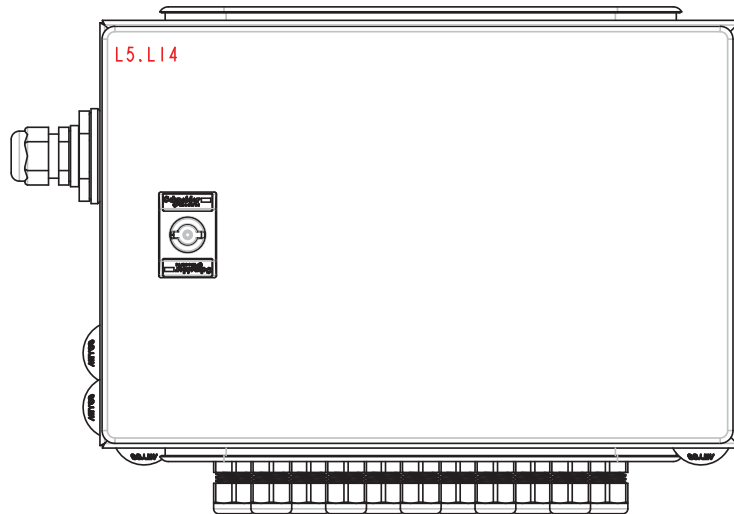
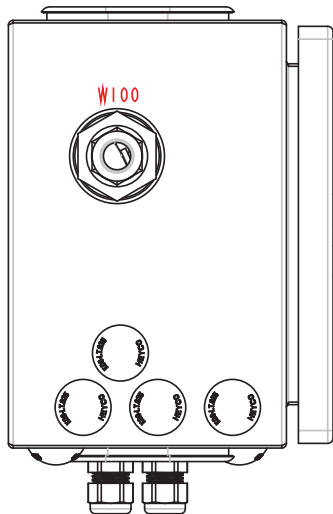
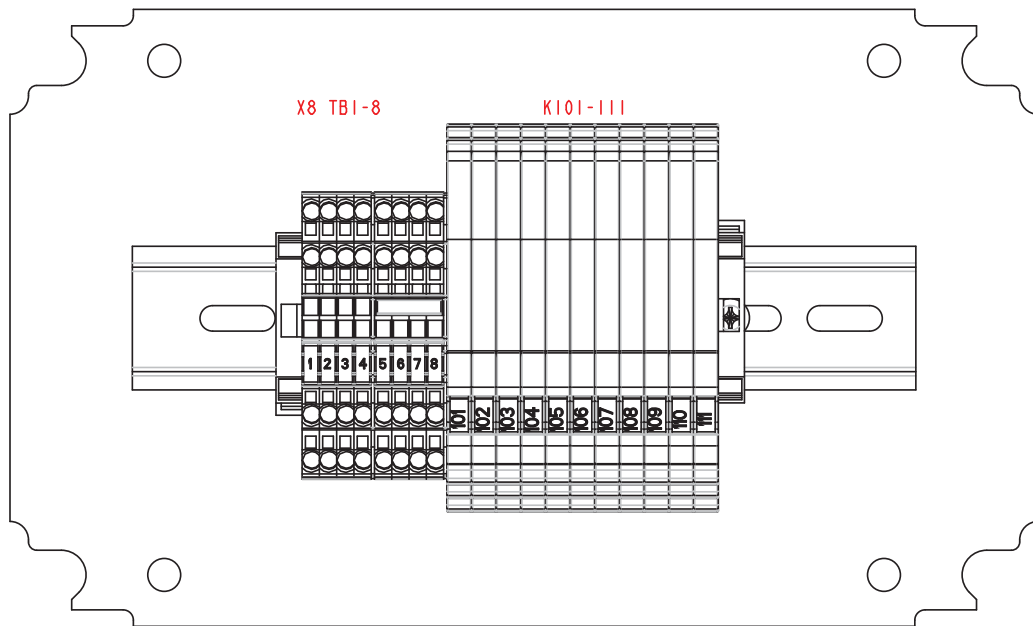

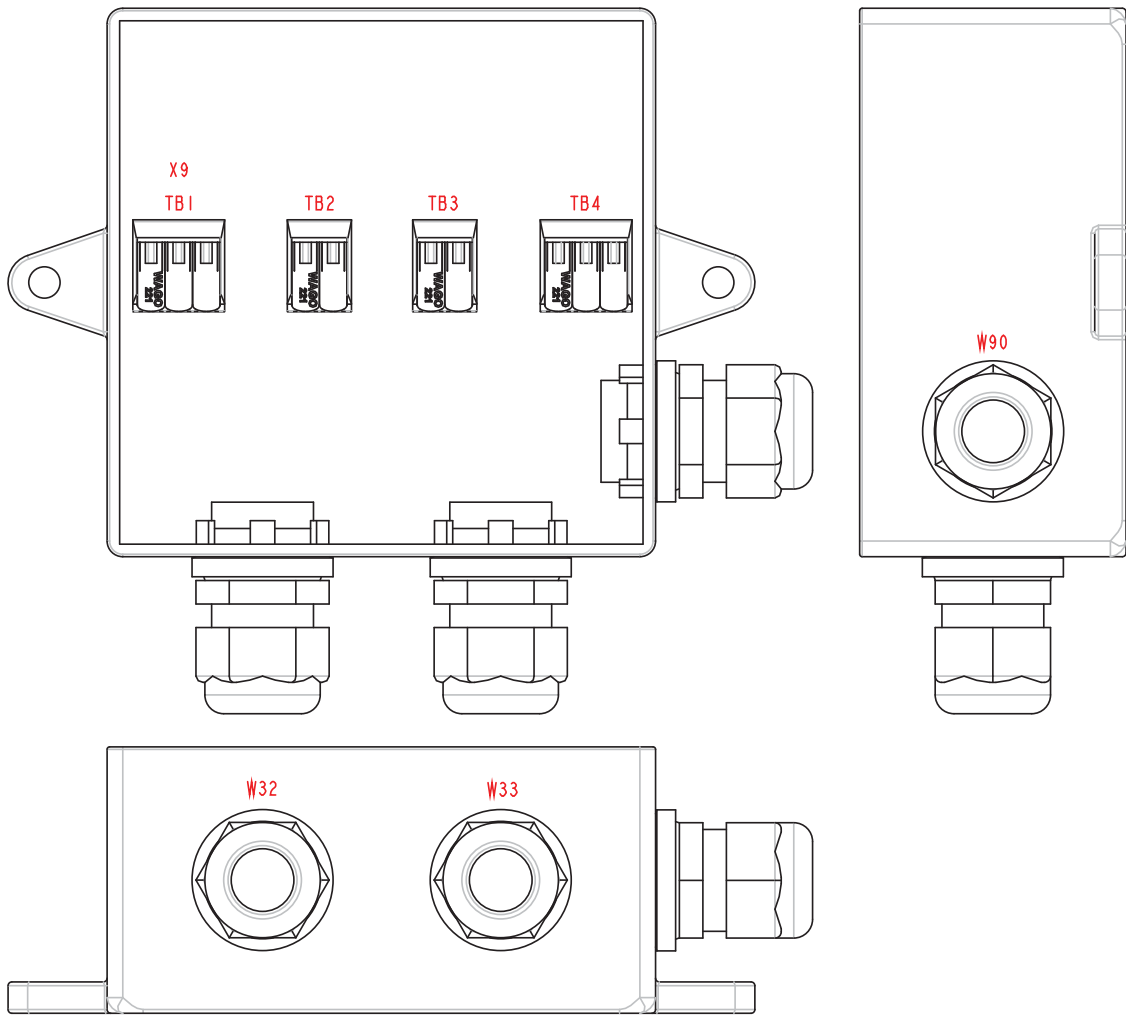

 Wood-Mizer®	
Project Description: WM4500	
Revision: A1.00	Pg Desc: Operator Ctl Bed Ex Layout
Mounting Location: +Docs	Type: Panel layout
Prev. pg: F8	Page: F9
Next pg: F10	Total Pgs: 78

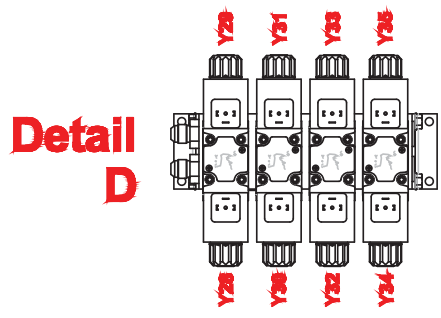
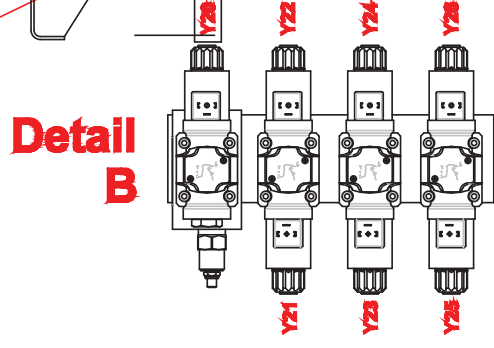
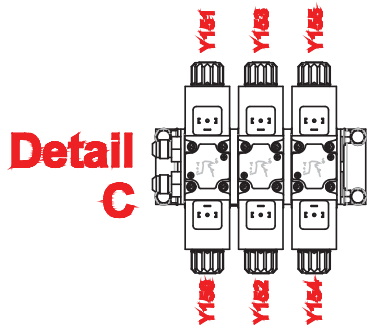
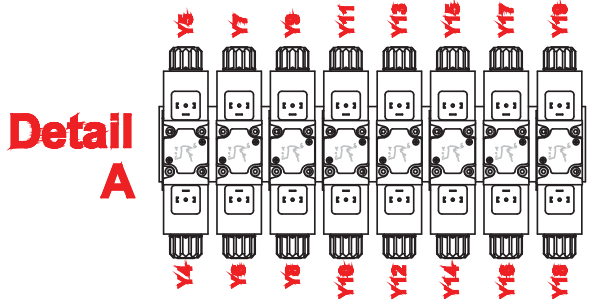
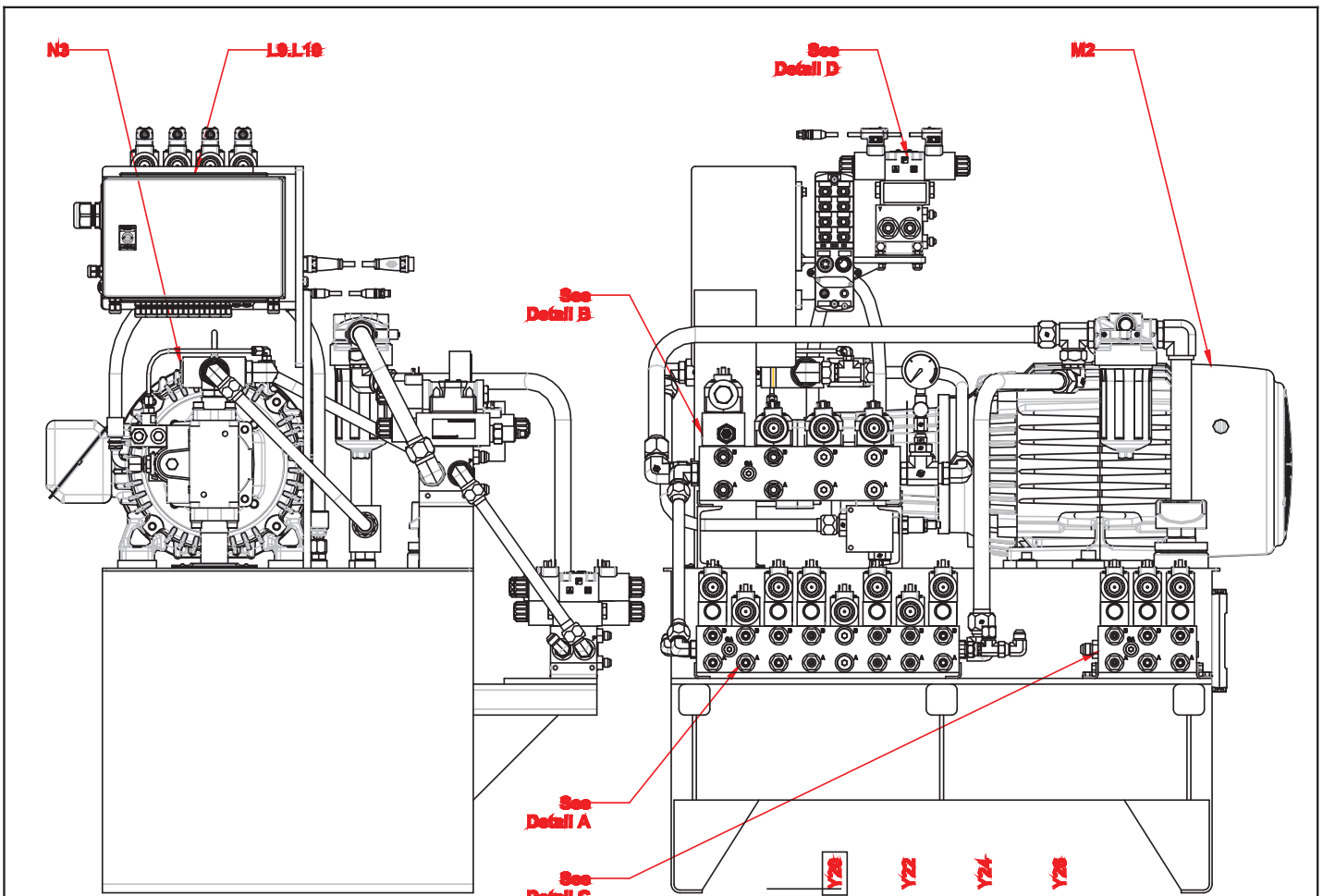

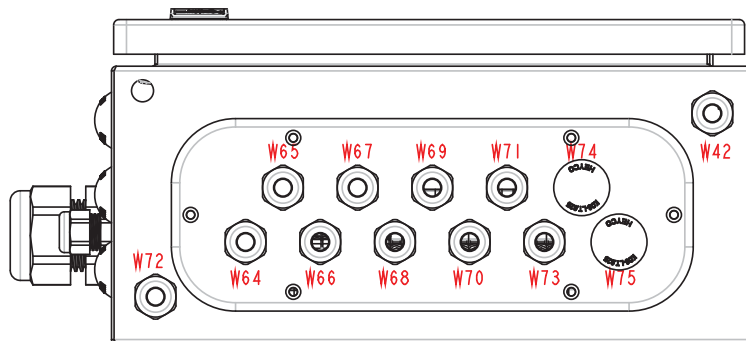
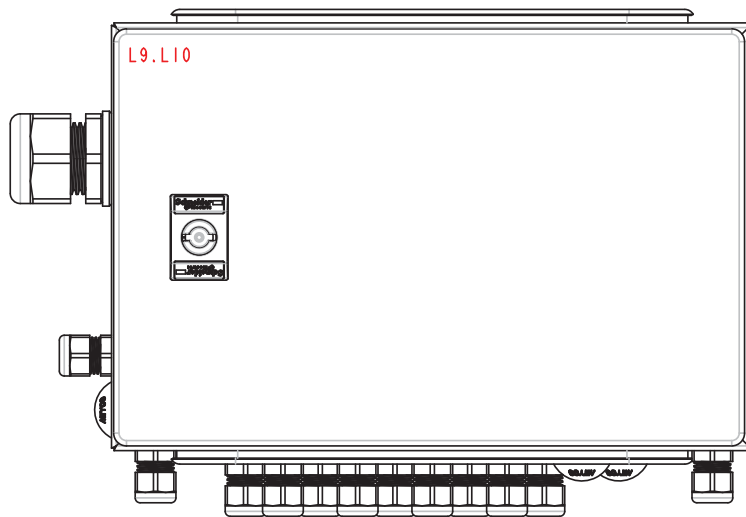
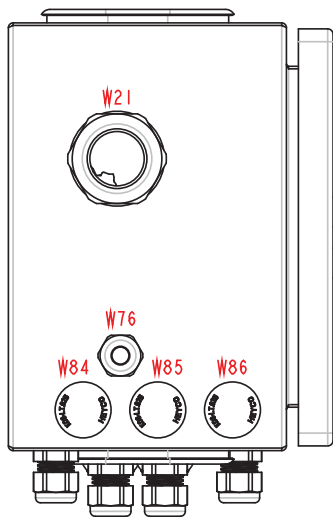
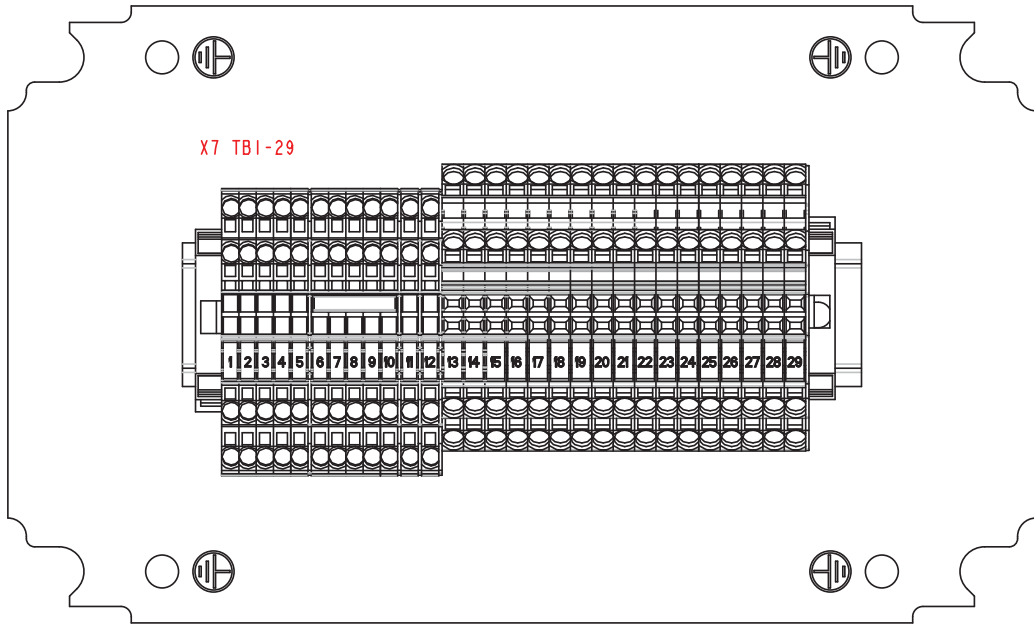

		Wood-Mizer®	
Project Description: WM4500			
Revision:	A1.00	Pg Desc: Hydraulic Control Layout	
Mounting Location:	+Docs	Type: Panel layout	
Prev. pg:	F10	Page:	F11
		Next pg:	F12
		Total Pgs:	78



		Wood-Mizer®	
Project Description: WM4500			
Revision:	A1.00	Pg Desc: Hydraulic Control Junction Layout	
Mounting Location:	+Docs	Type: Panel layout	
Prev. pg:	F11	Page:	F12
		Next pg:	F13
		Total Pgs:	78

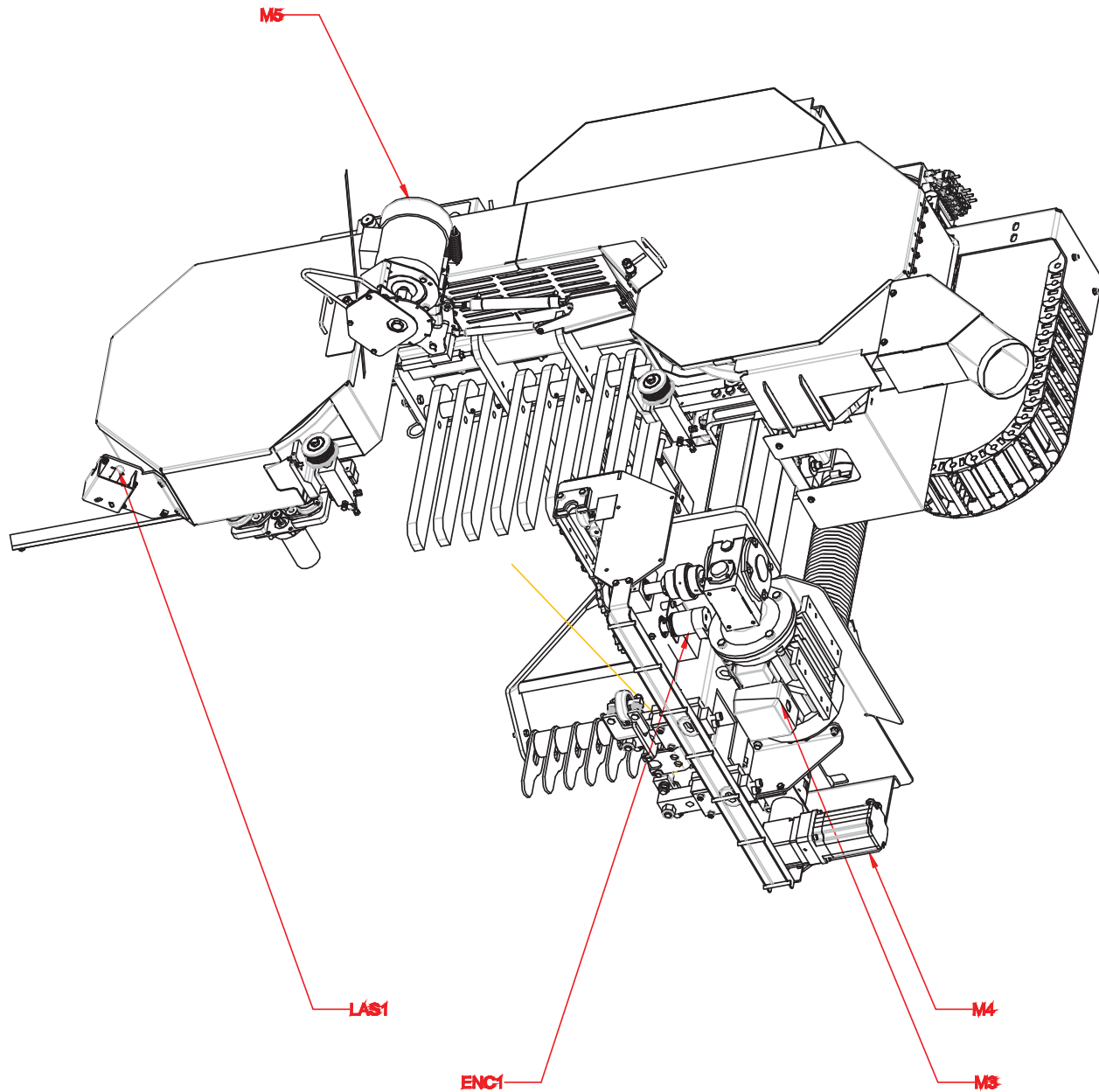

Wood-Mizer®

Project Description: WM4500

Revision: A1.00 Pg Desc: Head Control Layout Pg1

Mounting Location: +Docs Type: Panel layout

Prev. pg: F12 Page: F13 Next pg: F14 Total Pgs: 78

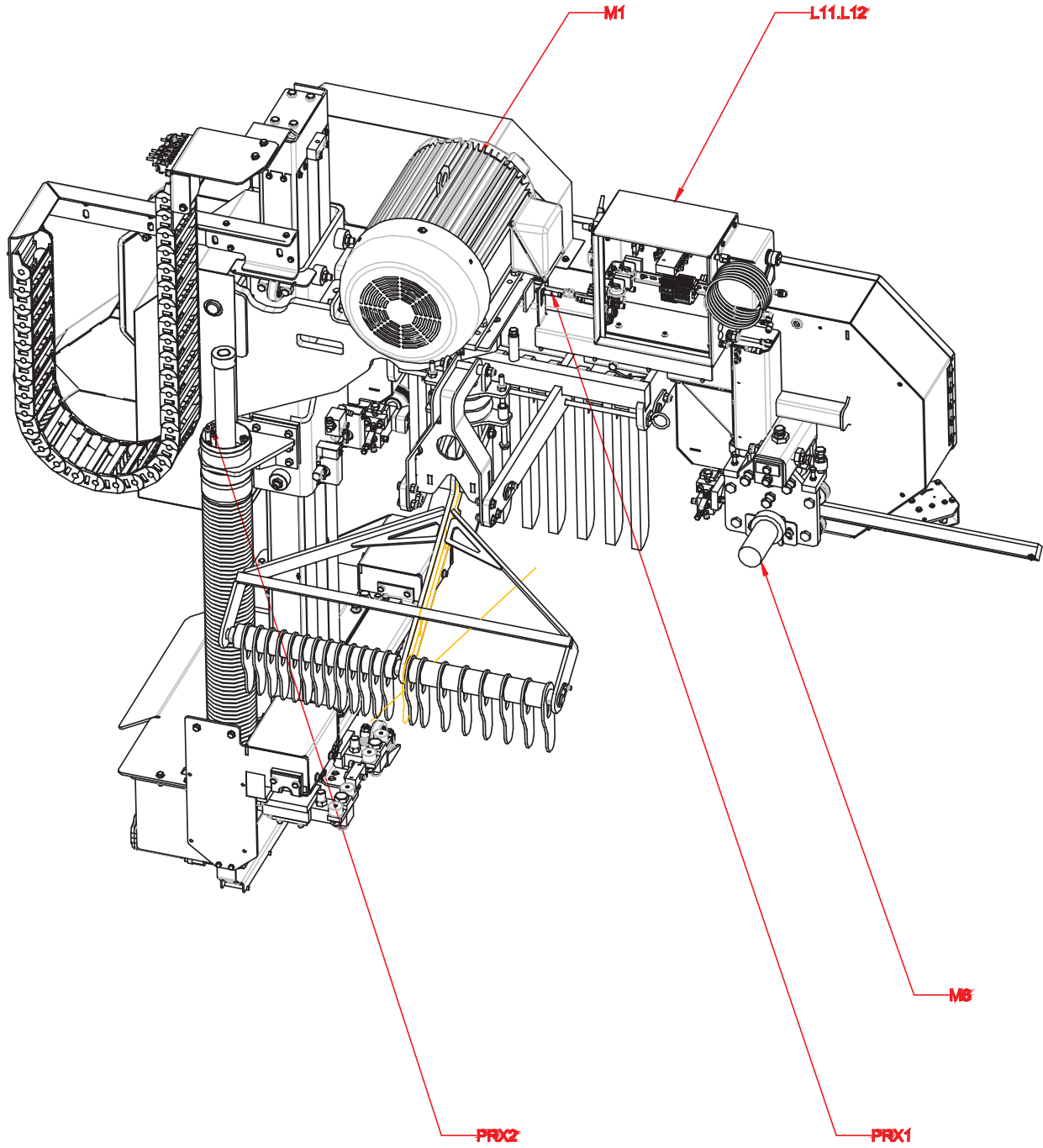

Wood-Mizer®

Project Description: WM4500

Revision:	A1.00	Pg Desc: Head Control Layout Pg2	
Mounting Location:	+Docs	Type: Panel layout	
Prev. pg:	F13	Page:	F14
		Next pg:	F15
		Total Pgs:	78

Y3 (Inside Cover)
Debarker In Solenoid

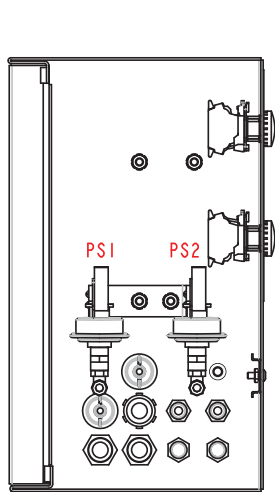
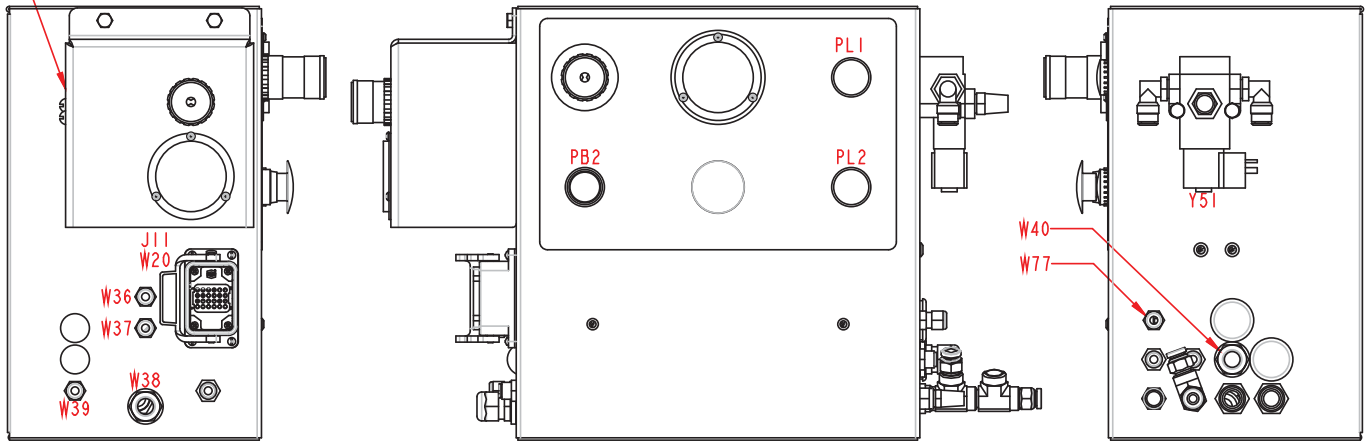

SECTION B-B

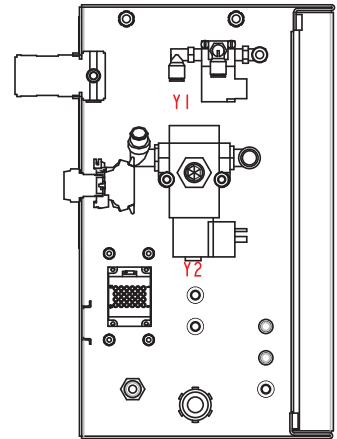
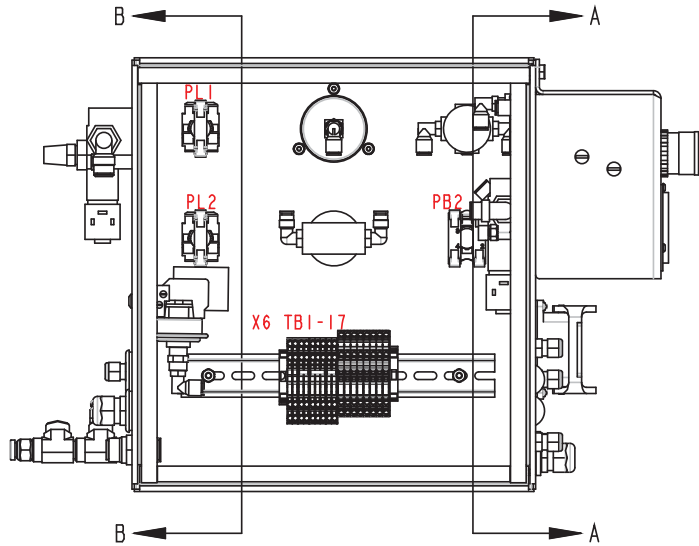

SECTION A-A



Wood-Mizer®

Project Description: WM4500

Revision: A1.00 Pg Desc: Head Control Junction Layout

Mounting Location: +Docs Type: Panel layout

Prev. pg: F14 Page: F15 Next pg+Mfg_Docs/GlTotal Pgs: 78