

WM3500-BX6 Layout w/Pantograph Cable Boom

See Page 2 for Foot Anchor Dimensions

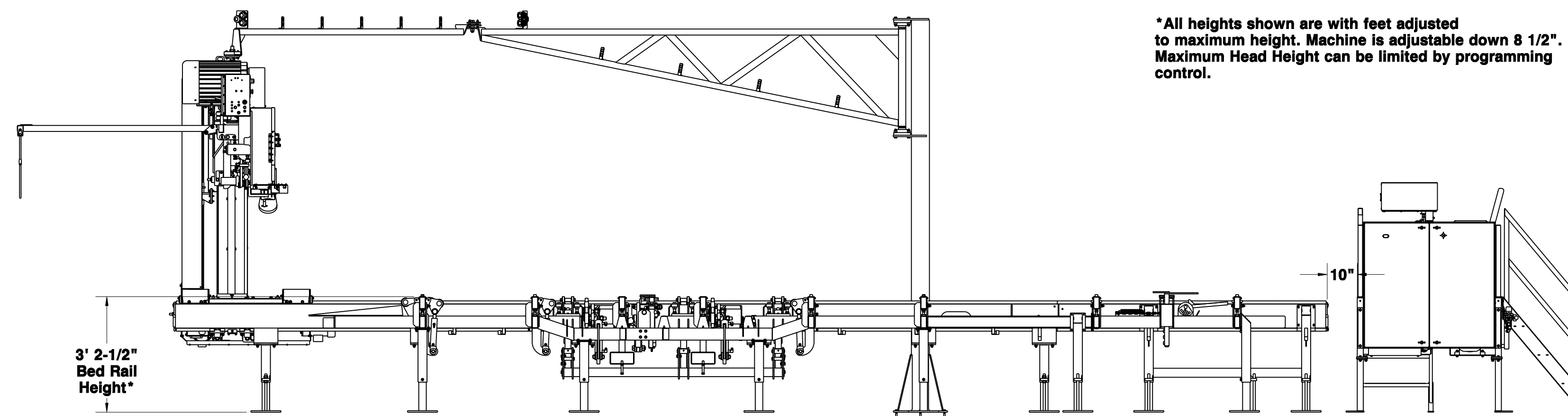

*All heights shown are with feet adjusted to maximum height. Machine is adjustable down 8 1/2". Maximum Head Height can be limited by programming control.

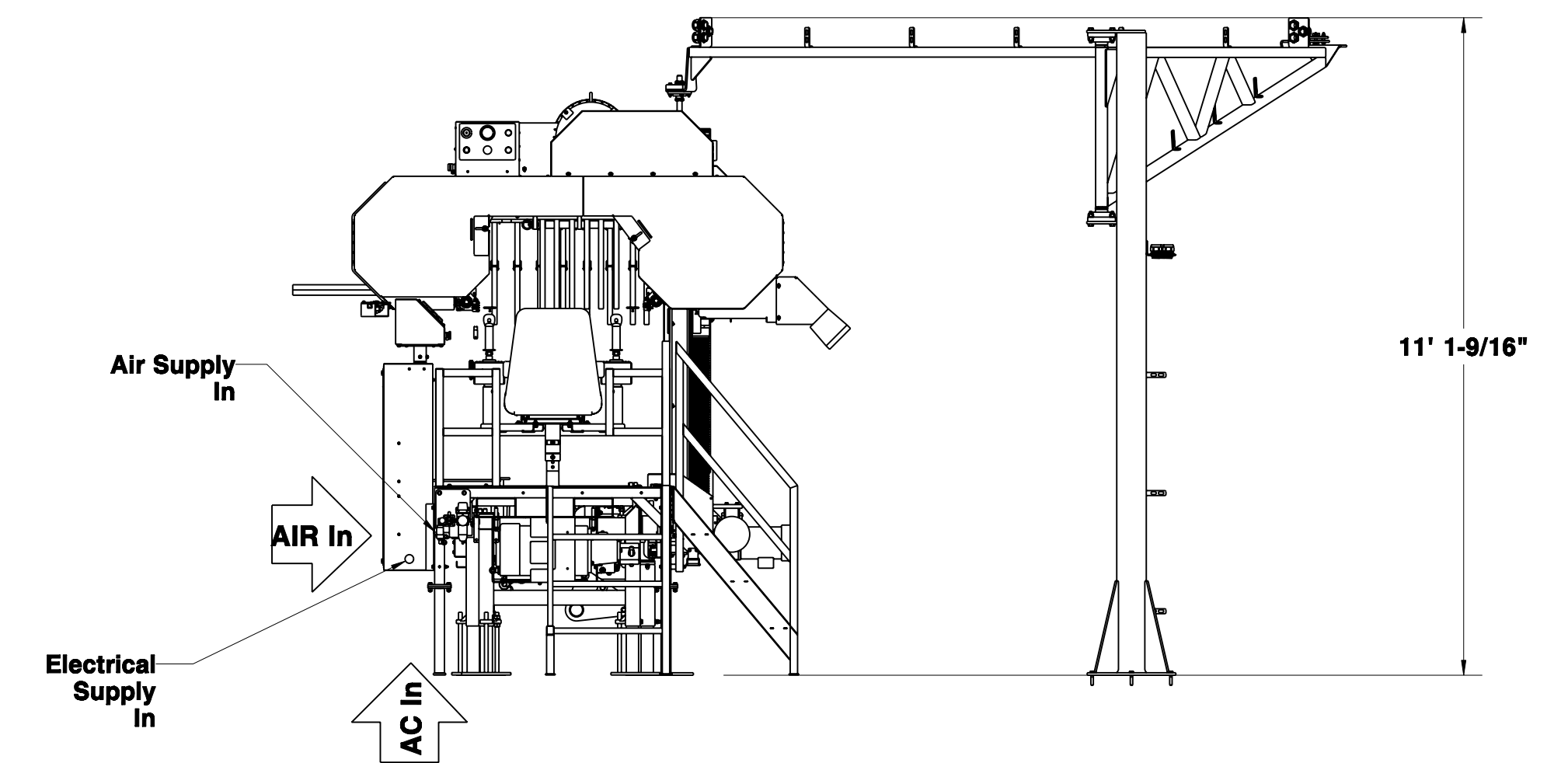

Installation Specifications

Concrete		Electrical/Air							
Min. Thickness	6"	Electrical Service	Volts	Phase	Amps	Wire Size (50' Max.)	Fused Disconnect	Time Delay Fuse	Shop Air
Rebar Diameter	1/2"	WM3500-BX6	460	3	100	4AWG	100A	70A	100 psi @ 16.5 cfm
Rebar Spacing	24"	Cab Option (no A/C)	110	1	15	N/A	N/A	N/A	N/A
Anchor Bolt Dia.	1/2"	Cab Option (w A/C)	110	1	30	N/A	N/A	N/A	N/A
Weight Capacity (at each foot location)	6350 lbs.	IC2-H Incline Conveyor Option	460	3	10	14AWG	N/A	N/A	N/A
NOTE: Be sure to provide enough room around equipment for operators, sawdust removal, log loading and board removal.		TD2 Transfer Deck Option	110	1			N/A	N/A	60 psi (regulated)
		Three-Way Deck Option	460	3	30	16AWG	30A	5A	100 psi (regulated) w/min. 50 gal. reserve & 3/4" supply line

WM3500-BX6 Foot Anchor Dimensions w/Pantograph

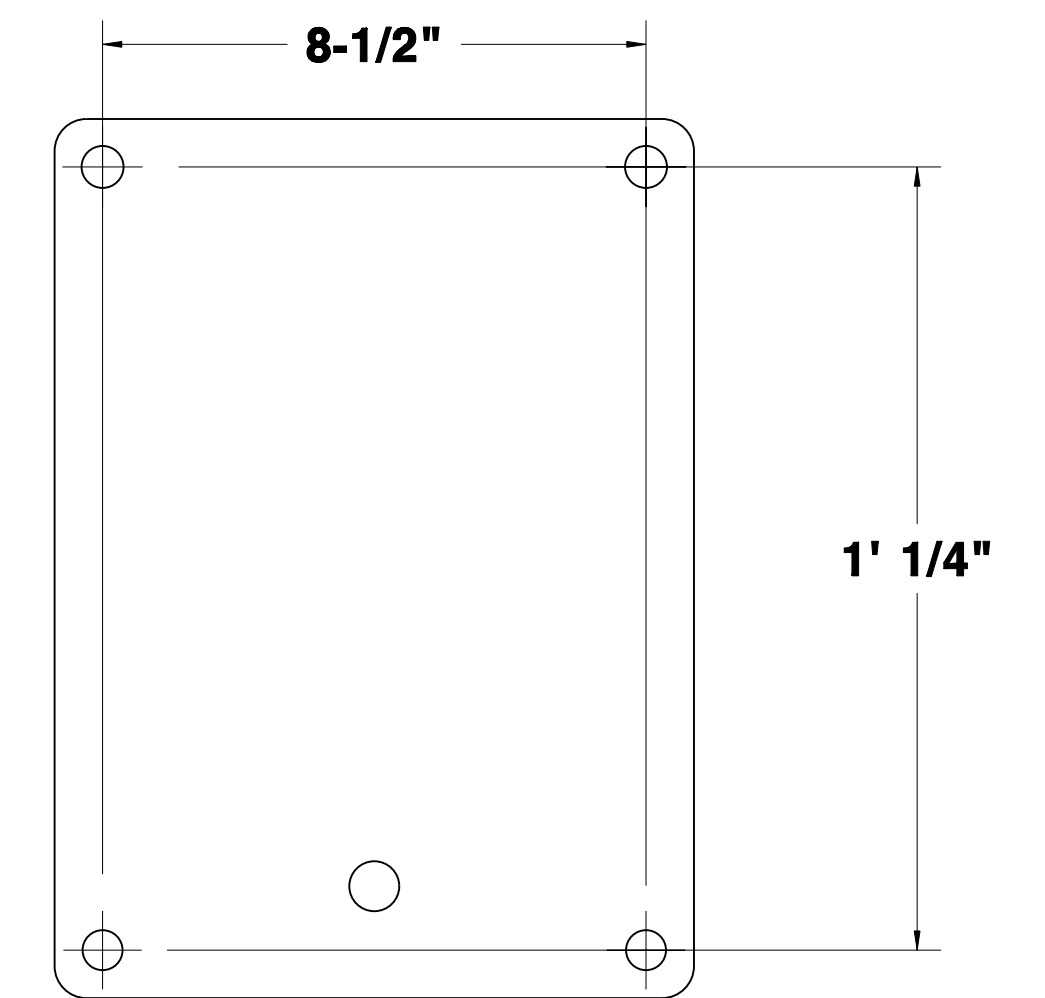
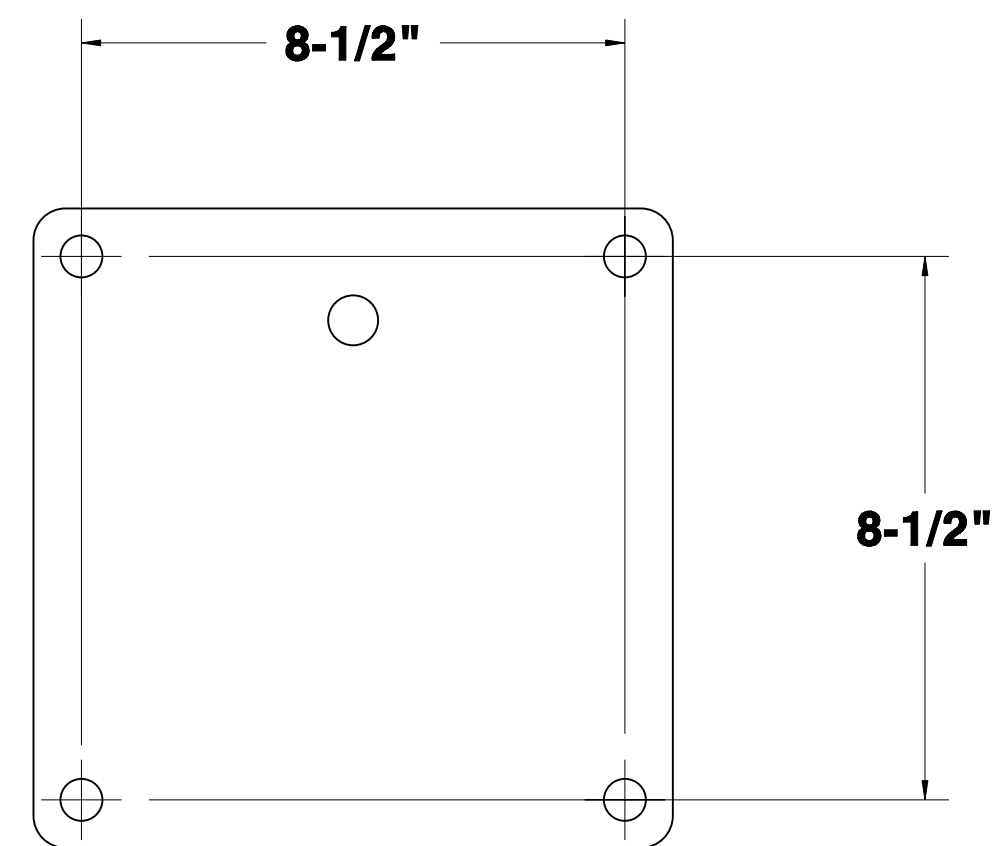
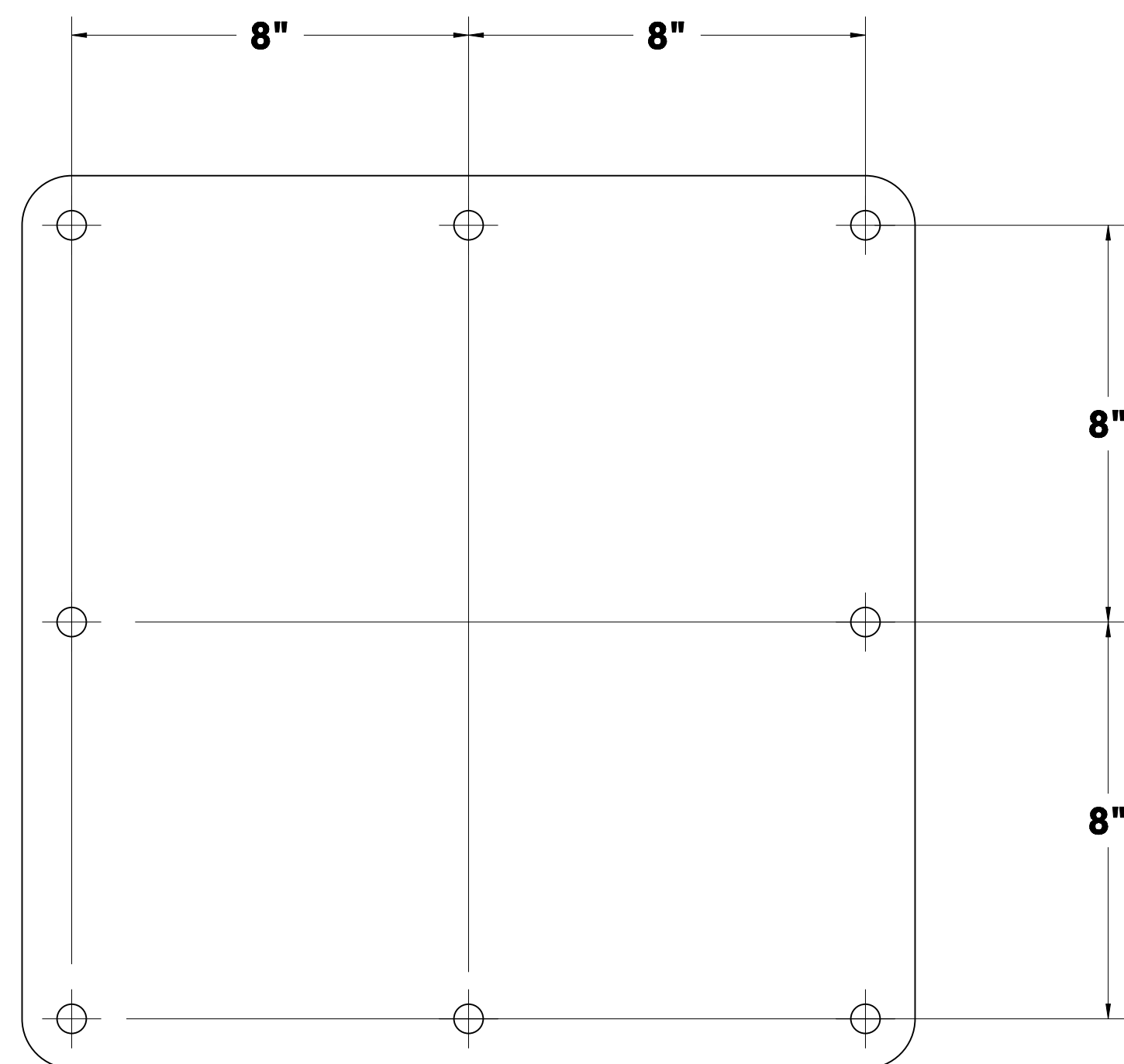
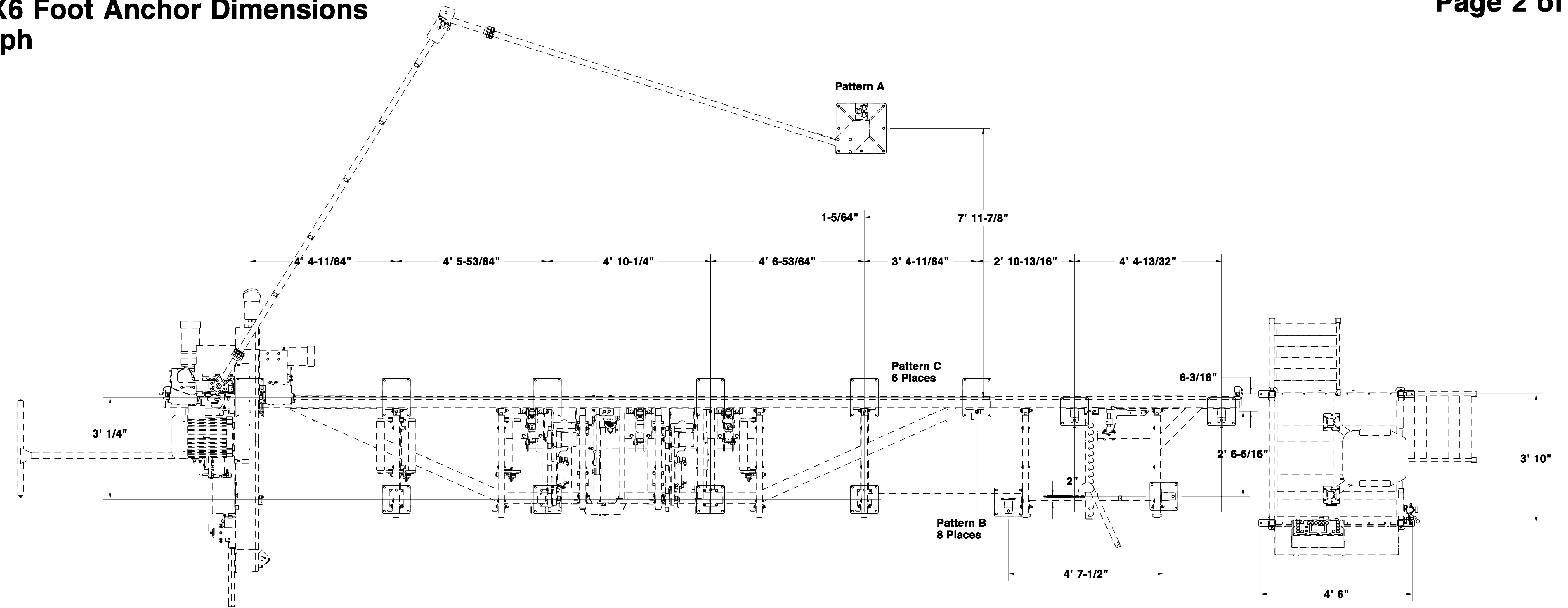

PATTERN 'A'

PATTERN 'B'

PATTERN 'C'

Log Deck & Incline Conveyor Important Dimensions

