

ELECTRICAL INFORMATION

HR130EC15-1 Rev. A6.05+

HR130EB15-1 Rev. A6.05+

APPENDIX B ELECTRICAL INFORMATION

HR130EC15-1

Rev. A6.05+

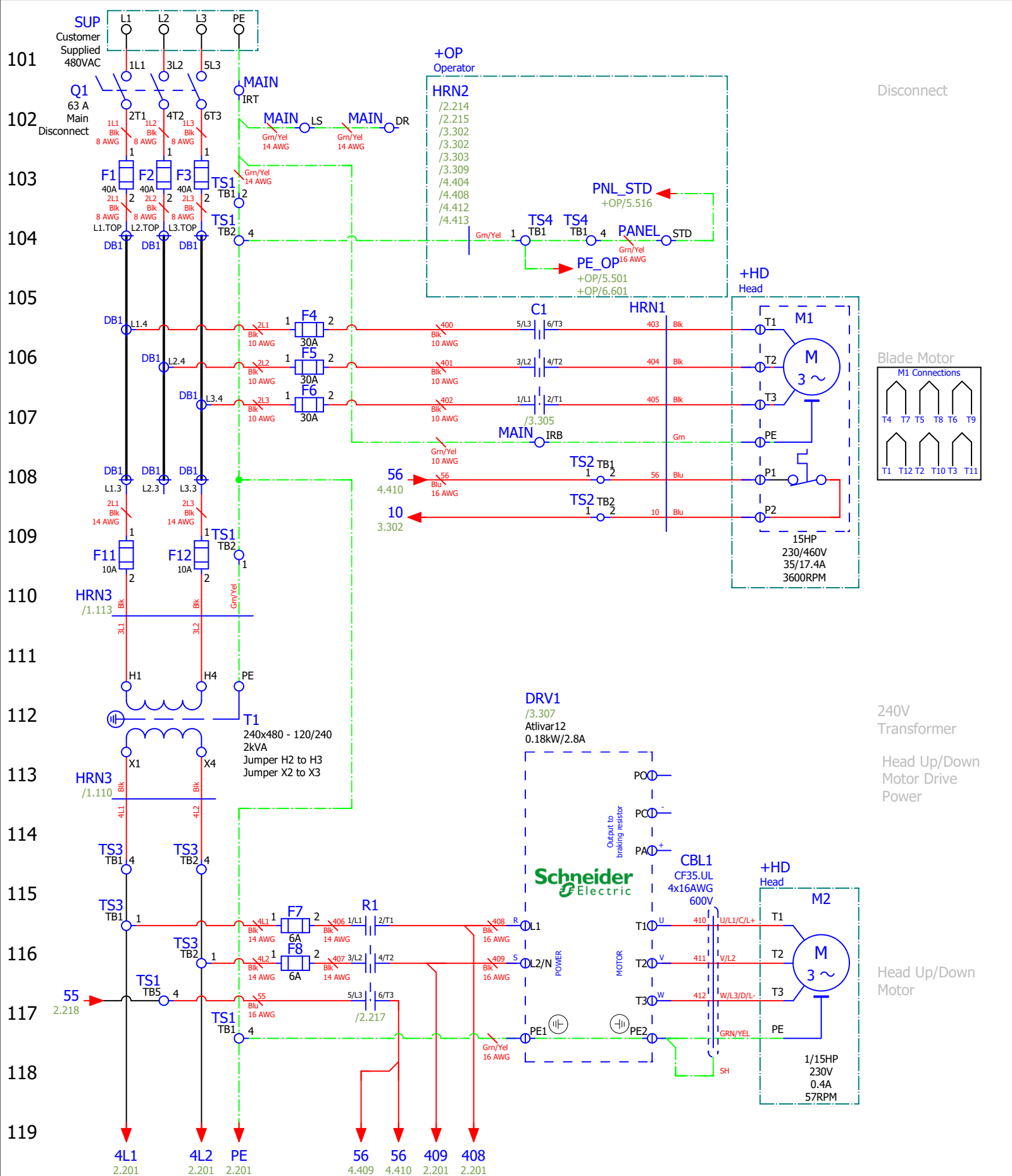

Disconnect

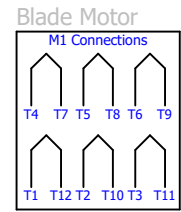

240V Transformer

Head Up/Down Motor Drive Power

Head Up/Down Motor

Wood-Mizer®

Project Description: HR130EC15-1

Revision:	A6.02	Pg Desc:	Power Pg 1
Mounting Location:	+MAIN	Type:	Schematic multi-line
Prev. pg:	+/B1	Page:	1
		Next pg:	2
		Total Pgs:	22

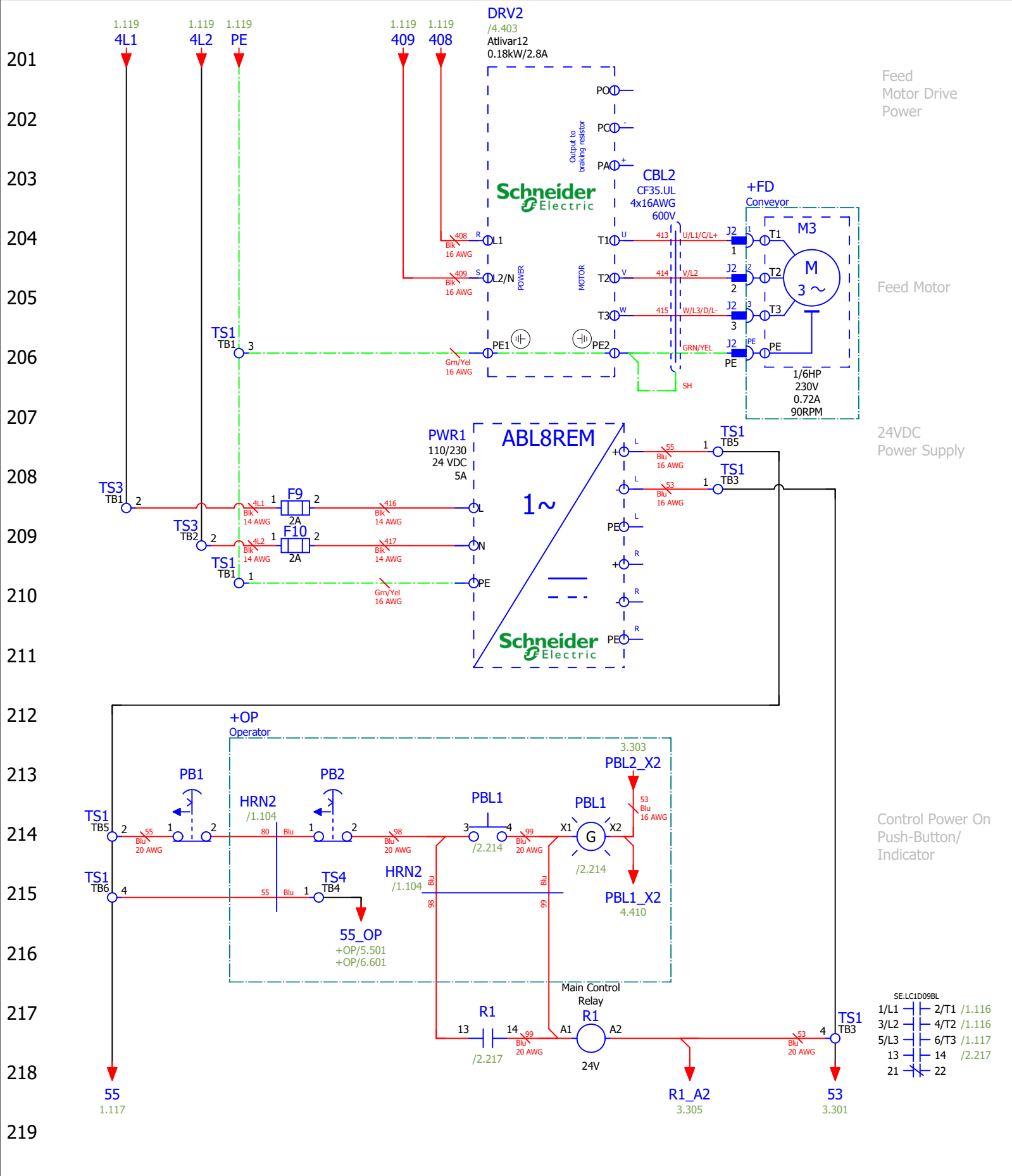

Feed
Motor Drive
Power

Feed Motor

24VDC
Power Supply

Control Power On
Push-Button/
Indicator

WM **Wood-Mizer®**

Project Description: HR130EC15-1

Revision:	A6.02	Pg Desc:	Power Pg 2
Mounting Location:	+MAIN	Type:	Schematic multi-line
Prev. pg:	1	Page:	2
Next pg:	3	Total Pgs:	22

301
302
303
304
305
306
307
308
309
310
311
312
313
314
315
316
317
318
319
320
321

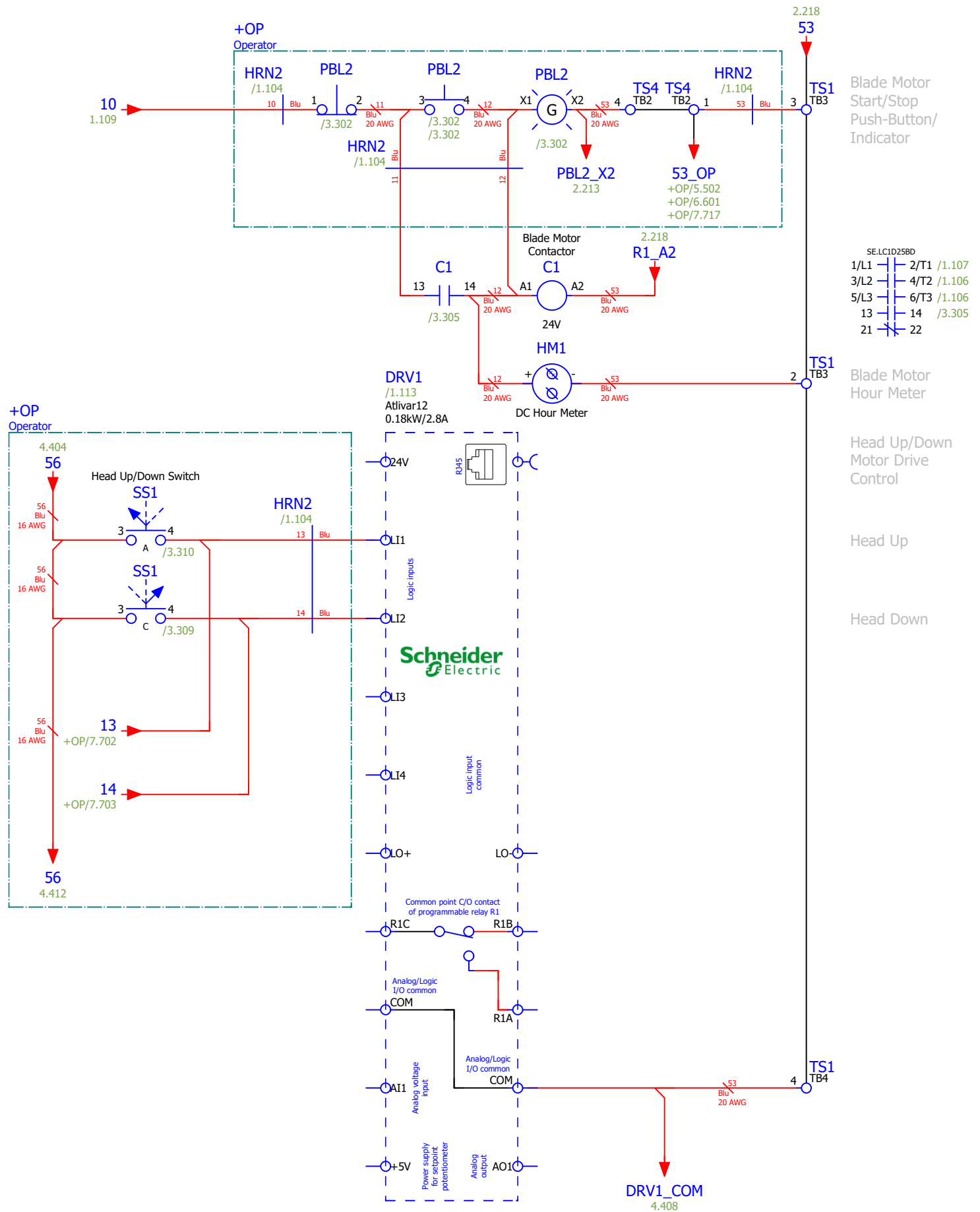

WM **Wood-Mizer®**

Project Description: HR130EC15-1

Revision: A6.02	Pg Desc: Control Pg 1
Mounting Location: +MAIN	Type: Schematic multi-line
Prev. pg: 2	Page: 3
Next pg: 4	Total Pgs: 22

401
402
403
404
405
406
407
408
409
410
411
412
413
414
415
416
417
418
419
420
421

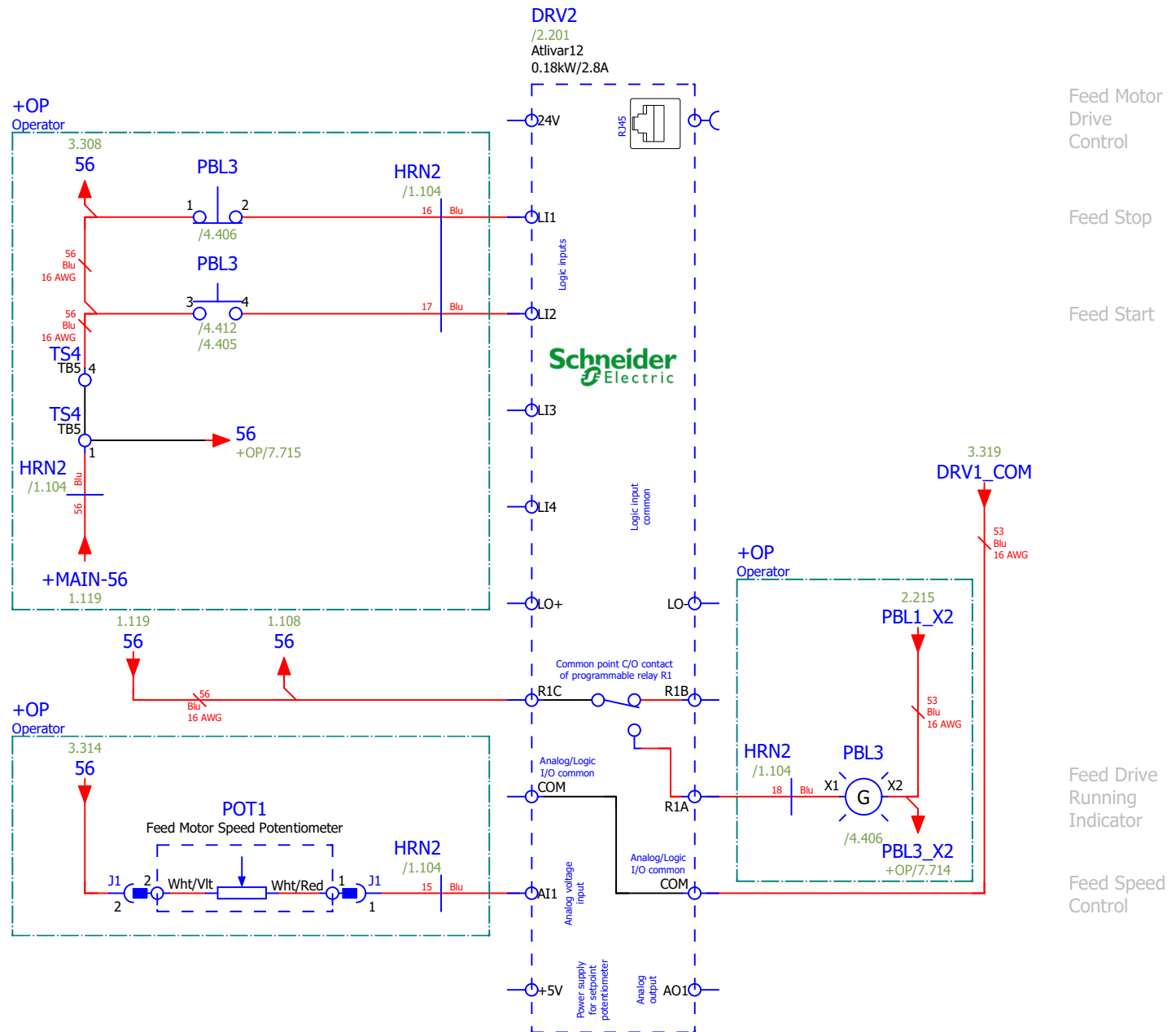

Feed Motor Drive Control
Feed Stop
Feed Start
Feed Drive Running Indicator
Feed Speed Control

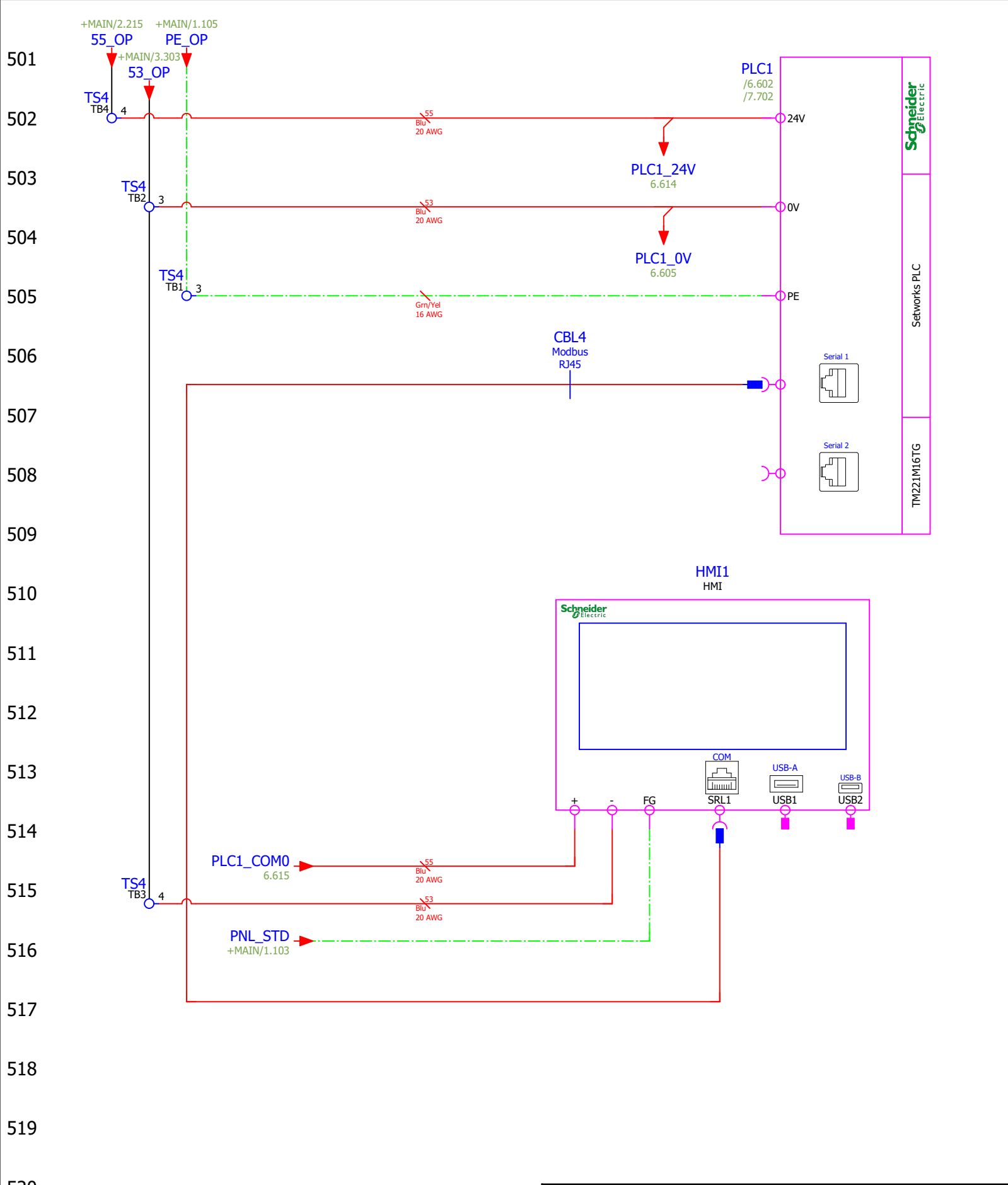

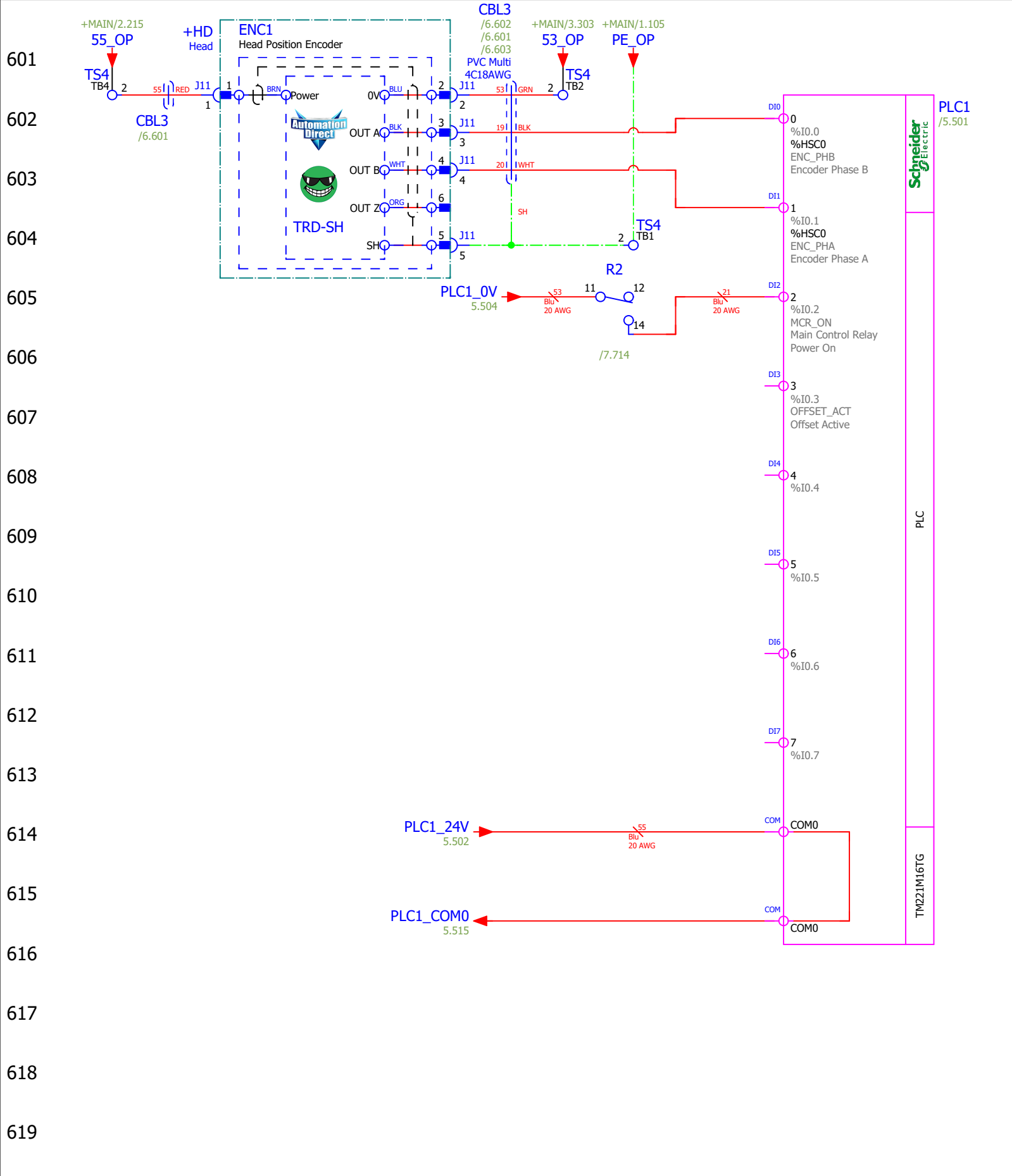

701
702
703
704
705
706
707
708
709
710
711
712
713
714
715
716
717
718
719
720
721

PLC1
/5.501

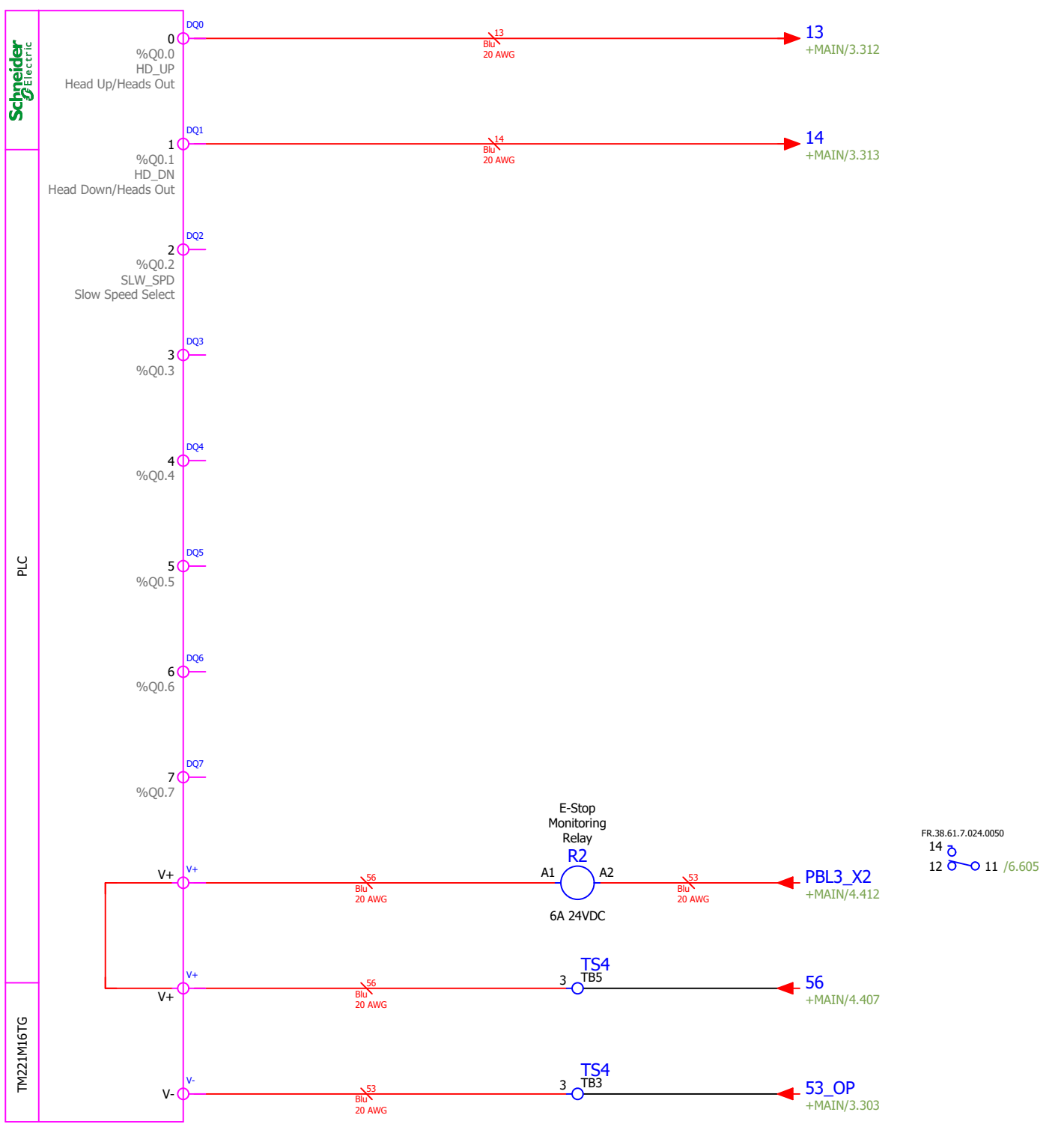

Device Tag/Parts List

WM_PARTS_LIST-Manual

Device tag	Function	Wood-Mizer Part Number	Wood-Mizer Description	Qty.	X-Ref
C1	Blade Motor Contactor	051322	Contacto, 25A 3P 24VDC Coil	1	+MAIN/3.305
DB1	Distribution Block	069701	Distribution Block, 3P 1 to 4	1	+MAIN/1.104
DRV1	Head Up/Down Motor Drive Power	069799	AC Drive Assy, HR130 Up/Down w/Software	1	+MAIN/1.113
DRV2	Feed Motor Drive Power	069800	Drive Assy, HR130 Feed w/Software	1	+MAIN/2.201
ENC1	Head Position Encoder	069840	Encoder Assy, HR130 Setworks	1	+OP/6.601
F1	Main L1 Fuse	053717	Fuseholder, 60A Cube	1	+MAIN/1.103
F1	=	069702	Fuse, 40A Class J Cube	1	+MAIN/1.103
F2	Main L2 Fuse	053717	Fuseholder, 60A Cube	1	+MAIN/1.103
F2	=	069702	Fuse, 40A Class J Cube	1	+MAIN/1.103
F3	Main L3 Fuse	053717	Fuseholder, 60A Cube	1	+MAIN/1.103
F3	=	069702	Fuse, 40A Class J Cube	1	+MAIN/1.103
F4	Blade Motor L1 Fuse	053736	Fuseholder, Cube 30A	1	+MAIN/1.106
F4	=	053737	Fuse, 30A Class J Cube	1	+MAIN/1.106
F5	Blade Motor L2 Fuse	053736	Fuseholder, Cube 30A	1	+MAIN/1.106
F5	=	053737	Fuse, 30A Class J Cube	1	+MAIN/1.106
F6	Blade Motor L3 Fuse	053736	Fuseholder, Cube 30A	1	+MAIN/1.107
F6	=	053737	Fuse, 30A Class J Cube	1	+MAIN/1.107
F7	Up/Down Motor Drive L1 Fuse	052512	Fuse Holder, 2P Class CC Screw Clamp	1	+MAIN/1.116
F7	=	052456	Fuse, 6A 600V Calss CC Delay	1	+MAIN/1.116
F8	Up/Down Motor Drive L2 Fuse	052456	Fuse, 6A 600V Calss CC Delay	1	+MAIN/1.116
F9	Power Supply L1 Fuse	052512	Fuse Holder, 2P Class CC Screw Clamp	1	+MAIN/2.209
F9	=	E22716	Fuse, 2A 600V Class CC	1	+MAIN/2.209
F10	Power Supply N Fuse	E22716	Fuse, 2A 600V Class CC	1	+MAIN/2.209
F11	Transformer H1 Fuse	052512	Fuse Holder, 2P Class CC Screw Clamp	1	+MAIN/1.109
F11	=	051957	Fuse, 10A 600V Class CC Delay	1	+MAIN/1.109
F12	Transformer H4 Fuse	051957	Fuse, 10A 600V Class CC Delay	1	+MAIN/1.109
HM1	Blade Motor Hour Meter	015401	Digital Meter, Hour Rect Mount w/Gasket	1	+MAIN/3.306
HMI1	HMI	112566.3	HMI Assy, PLC Setworks	1	+OP/5.510
M1	Blade Motor	130000	Motor, 15HP 3530RPM Marathon Premium Eff	1	+MAIN/1.105
M2	Head Up/Down Motor	025696	Motor, 1/15HP 57RPM 230V 3PH 30:1 Gear	1	+MAIN/1.116
M3	Feed Motor	073702	Motor, Leeson 0.167HP 230V 90RPM	1	+MAIN/2.204
PB1	Main E-Stop Push-Button	025161	Switch Body, 1NC 22mm ZB4	1	+MAIN/2.214
PB1	=	024945	Switch, PB E-Stop Maintnd Red 22mm ZB4	1	+MAIN/2.214
PB1	=	050992	Legend, E-Stop, Round Yellow	1	+MAIN/2.214
PB2	Operator E-Stop Push-Button	025161	Switch Body, 1NC 22mm ZB4	1	+MAIN/2.214
PB2	=	024945	Switch, PB E-Stop Maintnd Red 22mm ZB4	1	+MAIN/2.214
PB2	=	050992	Legend, E-Stop, Round Yellow	1	+MAIN/2.214
PBL1	Control Power On Push-Button	024974-3	Switch, PB Grn 22mm 1NO/1NC LED 24V XB4	1	+MAIN/2.214
PBL2	Blade Motor Start/Stop Push-Button	025236-31	Switch Body, 22mm Grn LED 1 NO 24V ZB4	1	+MAIN/3.302
PBL2	=	051746	Switch Operator, 2 Button w/Pilot Red/Gr	1	+MAIN/3.302
PBL2	=	050540	Contact, NC ZBE102	1	+MAIN/3.302
PBL2	=	052501	Boot, Clear Sealing ZB Sw	1	+MAIN/3.302
PBL3	Feed Motor Start/Stop Push-Button	025236-31	Switch Body, 22mm Grn LED 1 NO 24V ZB4	1	+MAIN/4.406
PBL3	=	051746	Switch Operator, 2 Button w/Pilot Red/Gr	1	+MAIN/4.406
PBL3	=	050540	Contact, NC ZBE102	1	+MAIN/4.406
PBL3	=	052501	Boot, Clear Sealing ZB Sw	1	+MAIN/4.406
PLC1	Setworks PLC	069849-3	PLC Ass, PLC Setworks	1	+OP/5.501
POT1	Feed Motor Speed Potentiometer	025200	Pot Assy, 4-20mA 24V W/conn	1	+MAIN/4.413
POT1	=	033476	O-Ring, 7/32 IN #009	2	+MAIN/4.413
POT1	=	033478	Knob, 1/4 ID Fluted Round Plastic	1	+MAIN/4.413
PWR1	24VDC Power Supply	069703	Power Supply, 24VDC 5A 110/230	1	+MAIN/2.207
Q1	Main Disconnect	050881-1	Disconnect, 63A 600V 3P 6mm Shaft	1	+MAIN/1.102
Q1	=	050908-1	Shaft, 290mm Pistol Grip Disconnect	1	+MAIN/1.102
Q1	=	050907-1	Handle, Disconnect Red/Yel Pistol Grip	1	+MAIN/1.102
R1	Main Control Relay	024890	Contacto, 9A 3P 24VDC Coil	1	+MAIN/2.217
R2	E-Stop Monitoring Relay	069883	Relay, 6A 24VDC w/ Cage Clamp Socket	1	+OP/7.714
SS1	Head Up/Down Switch	050545	Base, 2NO Contact	1	+MAIN/3.309

		Wood-Mizer®	
Project Description: HR130EC15-1			
Revision:	A6.02	Pg Desc: Parts list	
Mounting Location: +Docs		Type: Parts list	
Prev. pg: +OP/7	Page: C1	Next pg: C2	Total Pgs: 22

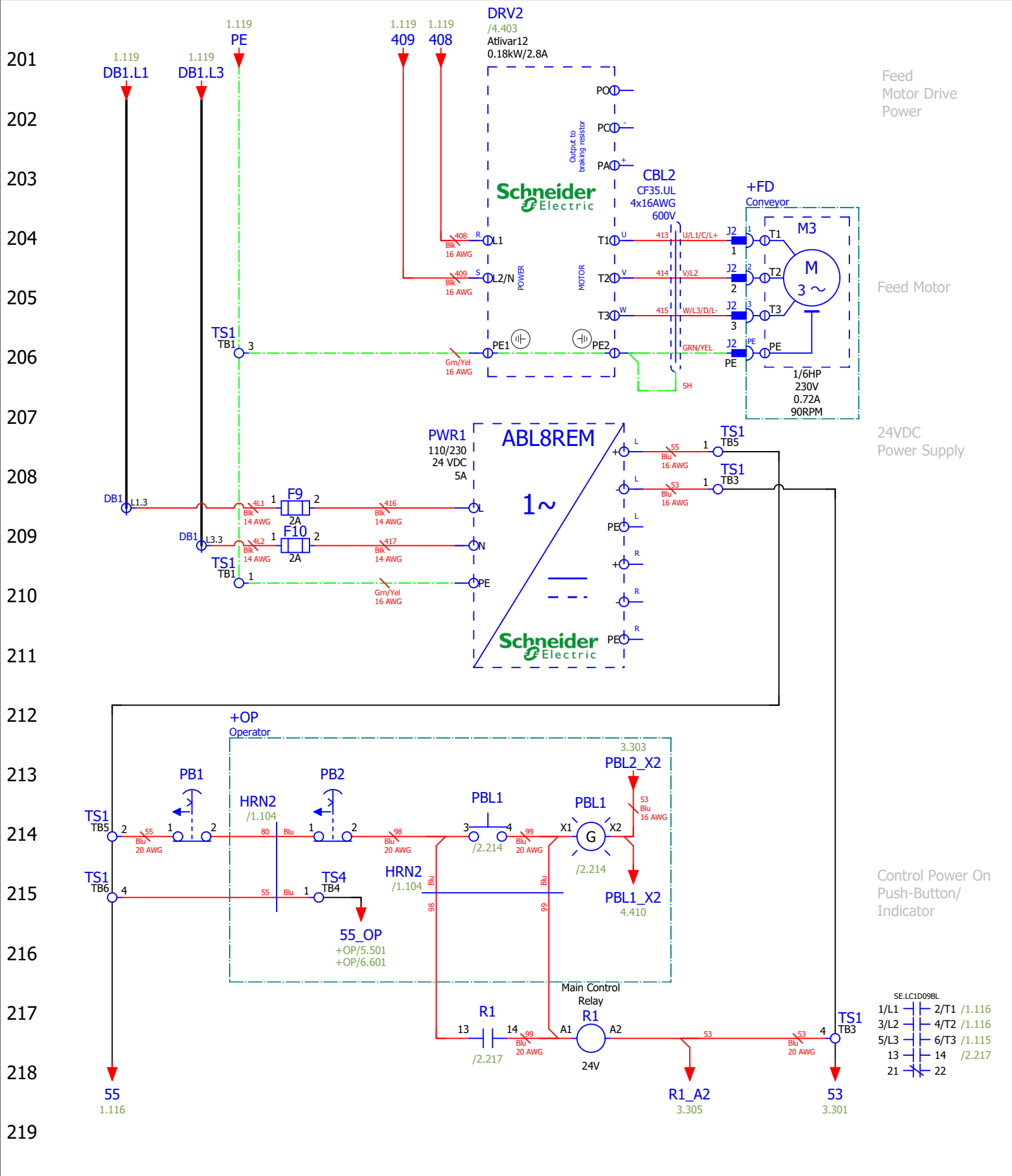

Feed
Motor Drive
Power

Feed Motor

24VDC
Power Supply

Control Power On
Push-Button/
Indicator

SE.LCID09BL

1/L1	2/T1	/1.116
3/L2	4/T2	/1.116
5/L3	6/T3	/1.115
13	14	/2.217
21	22	

Wood-Mizer®

Project Description: HR130EB15-1

Revision:	A6.02	Pg Desc: Power Pg 2
Mounting Location: +MAIN		Type: Schematic multi-line
Prev. pg:	1	Page: 2
		Next pg: 3
		Total Pgs: 20

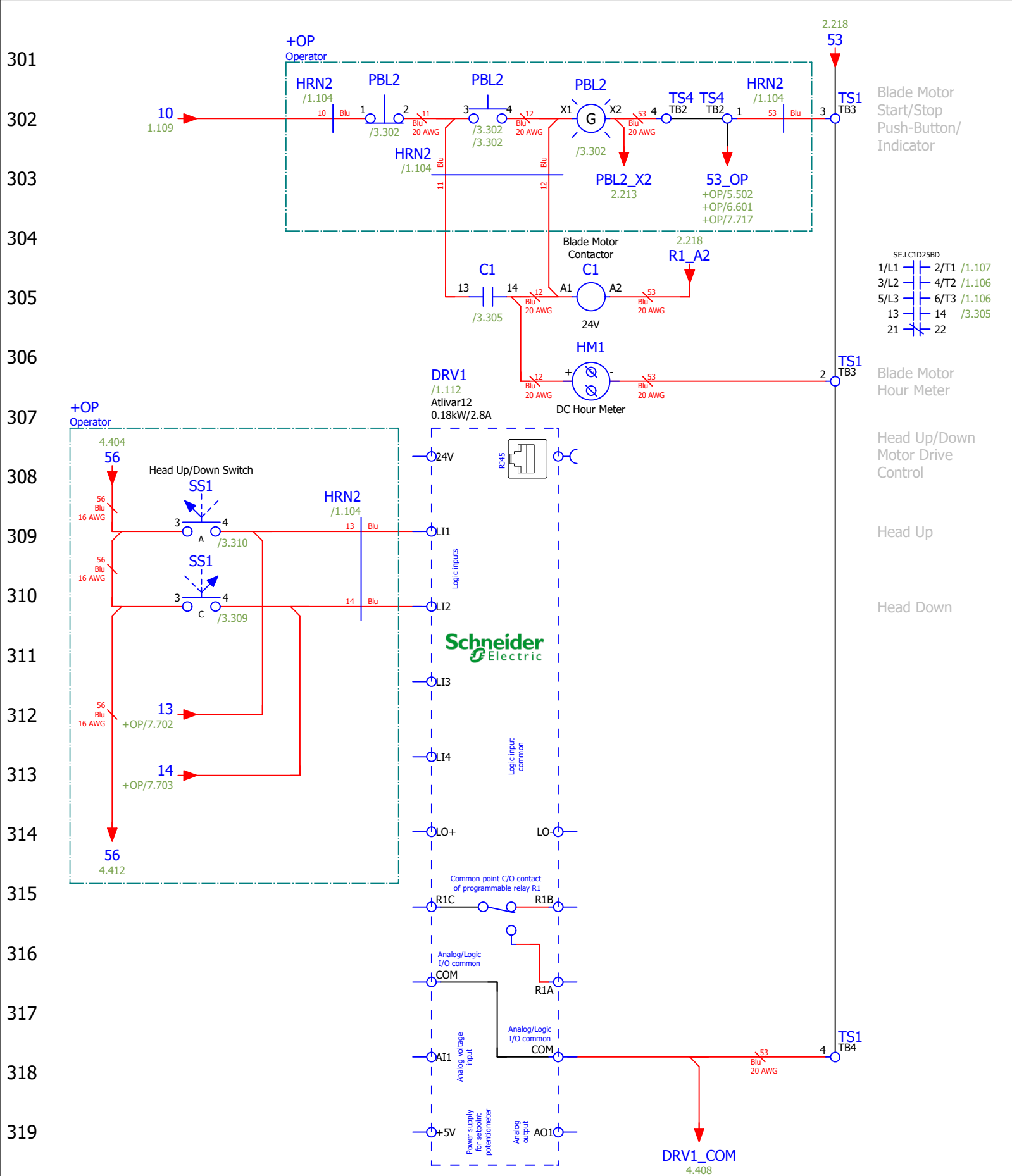

Blade Motor Start/Stop Push-Button/Indicator

SE.LCID258D
 1/L1 --- 2/T1 /1.107
 3/L2 --- 4/T2 /1.106
 5/L3 --- 6/T3 /1.106
 13 --- 14 /3.305
 21 --- 22

Blade Motor Hour Meter

Head Up/Down Motor Drive Control

Head Up

Head Down

Wood-Mizer®

Project Description: HR130EB15-1

Revision:	A6.02	Pg Desc:	Control Pg 1
Mounting Location:	+MAIN	Type:	Schematic multi-line
Prev. pg:	2	Page:	3
Next pg:	4	Total Pgs:	20

401
402
403
404
405
406
407
408
409
410
411
412
413
414
415
416
417
418
419
420
421

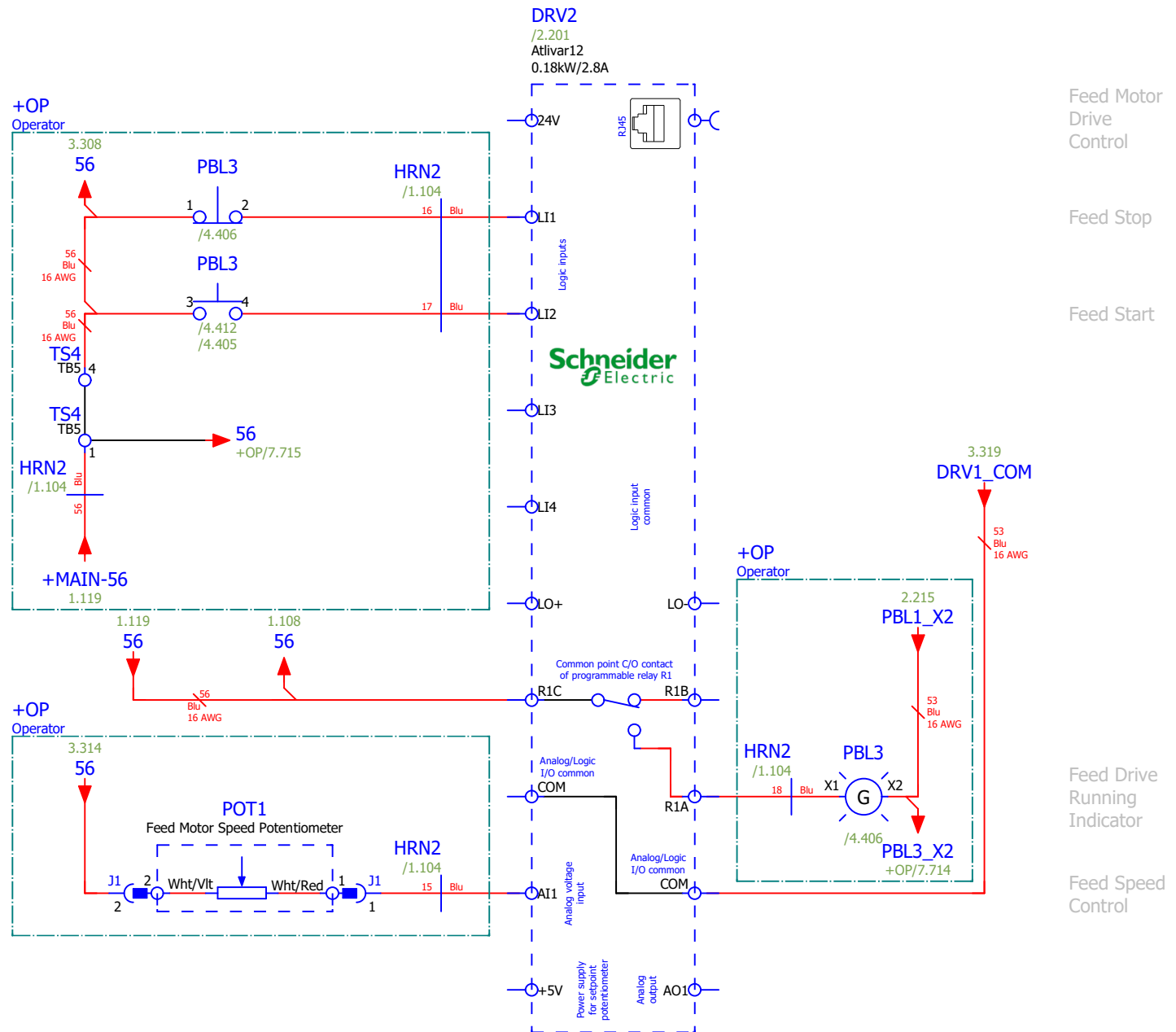

Feed Motor Drive Control
Feed Stop
Feed Start
Feed Drive Running Indicator
Feed Speed Control

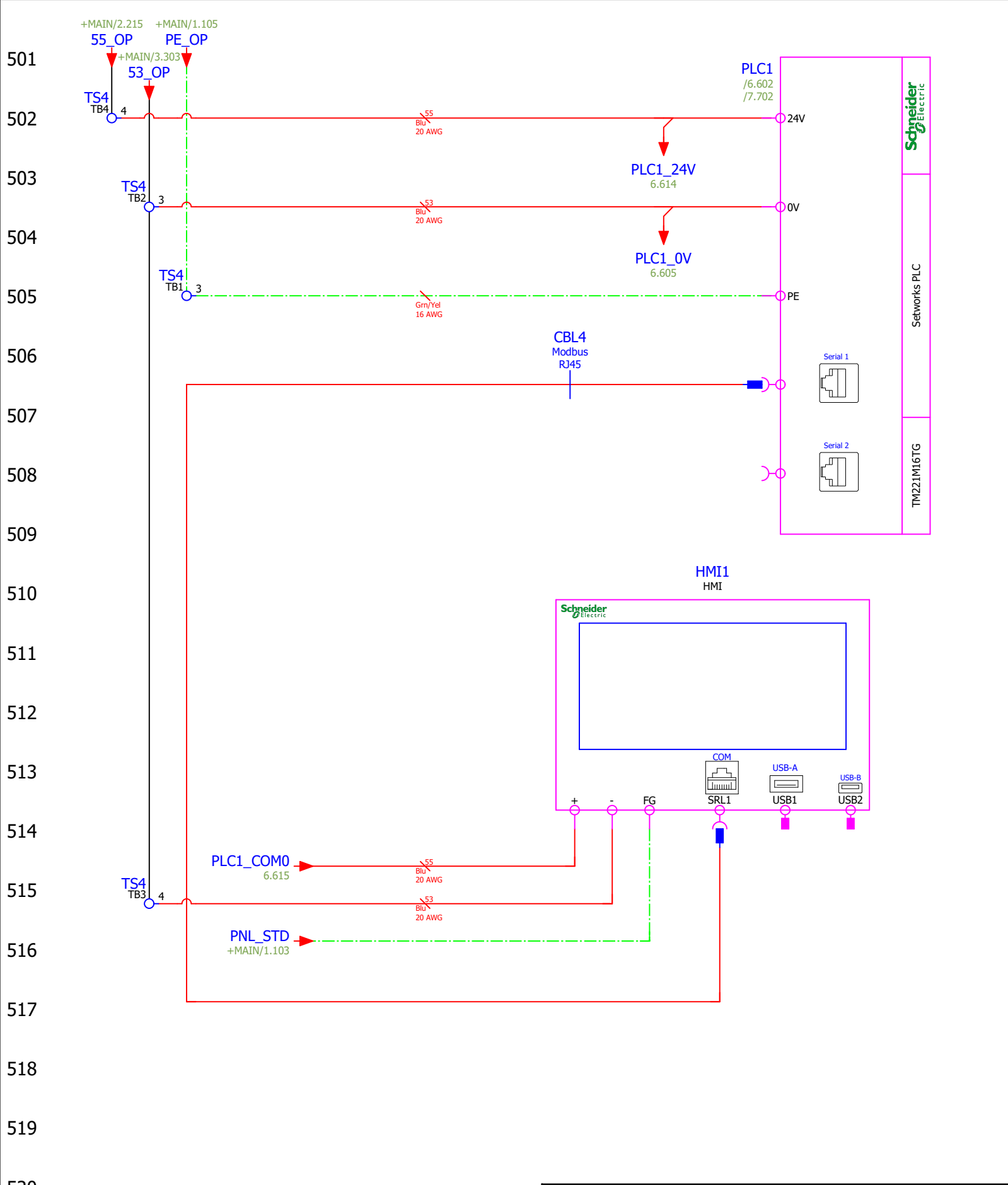

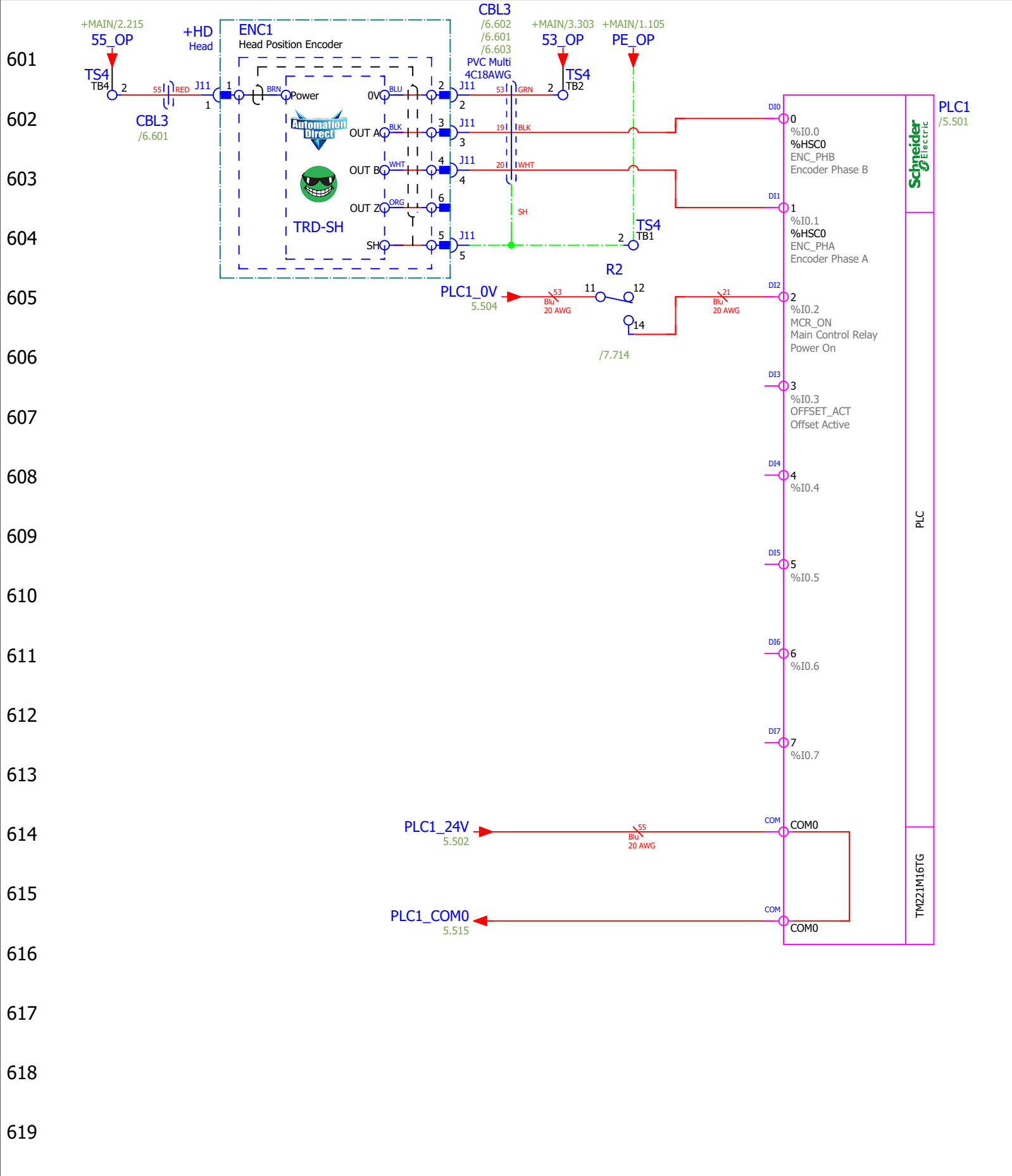

701
702
703
704
705
706
707
708
709
710
711
712
713
714
715
716
717
718
719
720
721

PLC1
/5.501

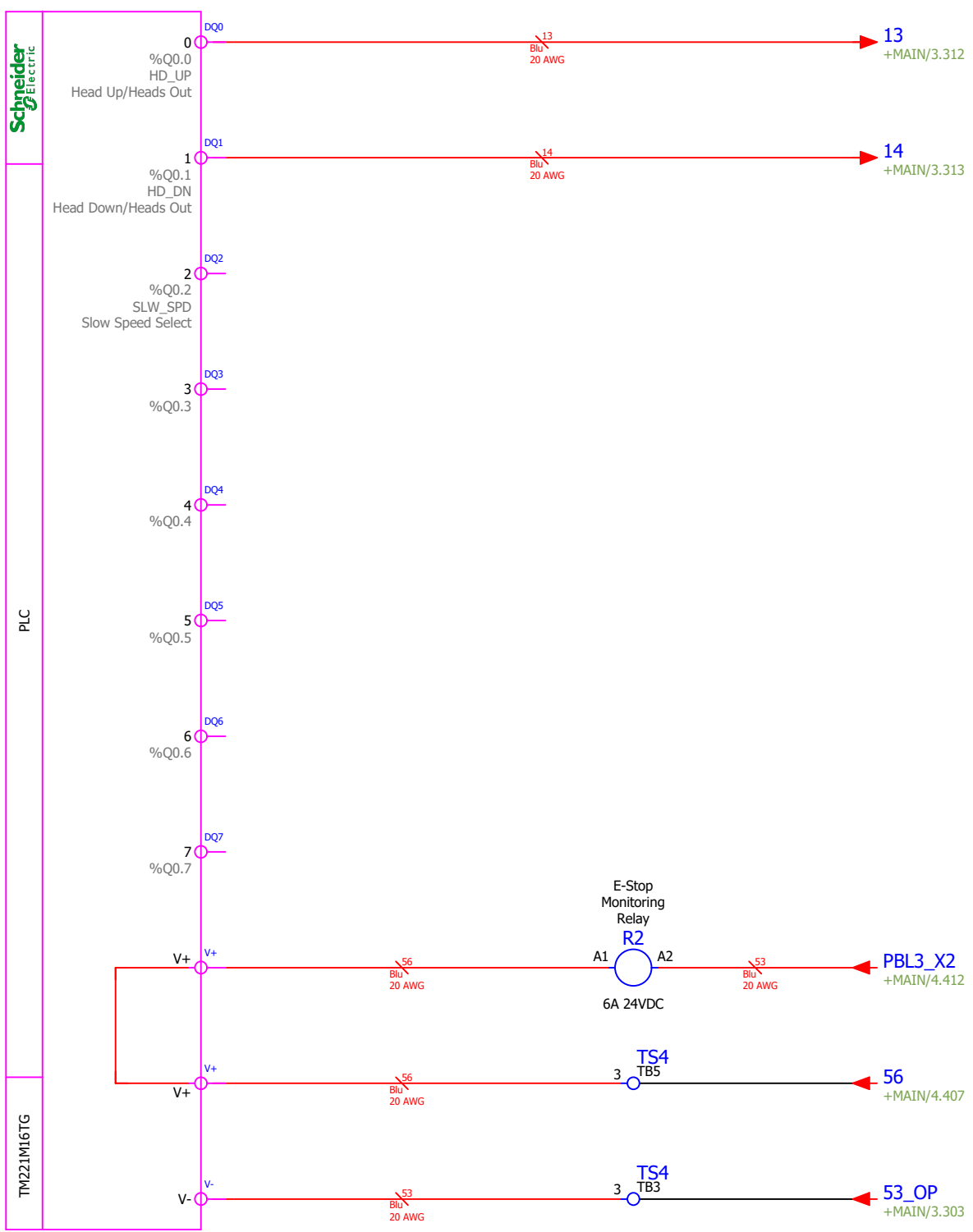

FR.38.61.7.024.0050
14
12 11 /6.605

Device Tag/Parts List

WM_PARTS_LIST-Manual

Device tag	Function	Wood-Mizer Part Number	Wood-Mizer Description	Qty.	X-Ref
C1	Blade Motor Contactor	051322	Contacto, 25A 3P 24VDC Coil	1	+MAIN/3.305
DB1	Distribution Block	069701	Distribution Block, 3P 1 to 4	1	+MAIN/1.104
DRV1	Head Up/Down Motor Drive Power	069799	AC Drive Assy, HR130 Up/Down w/Software	1	+MAIN/1.112
DRV2	Feed Motor Drive Power	069800	Drive Assy, HR130 Feed w/Software	1	+MAIN/2.201
ENC1	Head Position Encoder	069840	Encoder Assy, HR130 Setworks	1	+OP/6.601
F1	Main L1 Fuse	053586	Fuseholder, 100A Cube	1	+MAIN/1.103
F1	=	069707	Fuse, 70A Class J Cube	1	+MAIN/1.103
F2	Main L2 Fuse	053586	Fuseholder, 100A Cube	1	+MAIN/1.103
F2	=	069707	Fuse, 70A Class J Cube	1	+MAIN/1.103
F3	Main L3 Fuse	053586	Fuseholder, 100A Cube	1	+MAIN/1.103
F3	=	069707	Fuse, 70A Class J Cube	1	+MAIN/1.103
F4	Blade Motor L1 Fuse	053717	Fuseholder, 60A Cube	1	+MAIN/1.106
F4	=	069708	Fuse, 60A Class J Cube	1	+MAIN/1.106
F5	Blade Motor L2 Fuse	053717	Fuseholder, 60A Cube	1	+MAIN/1.106
F5	=	069708	Fuse, 60A Class J Cube	1	+MAIN/1.106
F6	Blade Motor L3 Fuse	053717	Fuseholder, 60A Cube	1	+MAIN/1.107
F6	=	069708	Fuse, 60A Class J Cube	1	+MAIN/1.107
F7	Up/Down Motor Drive L1 Fuse	052512	Fuse Holder, 2P Class CC Screw Clamp	1	+MAIN/1.115
F7	=	052456	Fuse, 6A 600V Calss CC Delay	1	+MAIN/1.115
F8	Up/Down Motor Drive L2 Fuse	052456	Fuse, 6A 600V Calss CC Delay	1	+MAIN/1.116
F9	Power Supply L1 Fuse	052512	Fuse Holder, 2P Class CC Screw Clamp	1	+MAIN/2.209
F9	=	E22716	Fuse, 2A 600V Class CC	1	+MAIN/2.209
F10	Power Supply N Fuse	E22716	Fuse, 2A 600V Class CC	1	+MAIN/2.209
HM1	Blade Motor Hour Meter	015401	Digital Meter, Hour Rect Mount w/Gasket	1	+MAIN/3.306
HMI1	HMI	112566.3	HMI Assy, PLC Setworks	1	+OP/5.510
M1	Blade Motor	130000	Motor, 15HP 3530RPM Marathon Premium Eff	1	+MAIN/1.105
M2	Feed Motor	025696	Motor, 1/15HP 57RPM 230V 3PH 30:1 Gear	1	+MAIN/1.115
M3	=	073702	Motor Assy, HR130 Feed Conveyor	1	+MAIN/2.204
PB1	Main E-Stop Push-Button	025161	Switch Body, 1NC 22mm ZB4	1	+MAIN/2.214
PB1	=	024945	Switch, PB E-Stop Maintnd Red 22mm ZB4	1	+MAIN/2.214
PB1	=	050992	Legend, E-Stop, Round Yellow	1	+MAIN/2.214
PB2	Operator E-Stop Push-Button	025161	Switch Body, 1NC 22mm ZB4	1	+MAIN/2.214
PB2	=	024945	Switch, PB E-Stop Maintnd Red 22mm ZB4	1	+MAIN/2.214
PB2	=	050992	Legend, E-Stop, Round Yellow	1	+MAIN/2.214
PBL1	Control Power On Push-Button	024974-3	Switch, PB Grn 22mm 1NO/1NC LED 24V XB4	1	+MAIN/2.214
PBL2	Blade Motor Start/Stop Push-Button	025236-31	Switch Body, 22mm Grn LED 1 NO 24V ZB4	1	+MAIN/3.302
PBL2	=	051746	Switch Operator, 2 Button w/Pilot Red/Gr	1	+MAIN/3.302
PBL2	=	050540	Contact, NC ZBE102	1	+MAIN/3.302
PBL2	=	052501	Boot, Clear Sealing ZB Sw	1	+MAIN/3.302
PBL3	Feed Motor Start/Stop Push-Button	025236-31	Switch Body, 22mm Grn LED 1 NO 24V ZB4	1	+MAIN/4.406
PBL3	=	051746	Switch Operator, 2 Button w/Pilot Red/Gr	1	+MAIN/4.406
PBL3	=	050540	Contact, NC ZBE102	1	+MAIN/4.406
PBL3	=	052501	Boot, Clear Sealing ZB Sw	1	+MAIN/4.406
PLC1	Setworks PLC	069849-3	PLC Ass, PLC Setworks	1	+OP/5.501
POT1	Feed Motor Speed Potentiometer	025200	Pot Assy, 4-20mA 24V W/conn	1	+MAIN/4.413
POT1	=	033476	O-Ring, 7/32 IN #009	2	+MAIN/4.413
POT1	=	033478	Knob, 1/4 ID Fluted Round Plastic	1	+MAIN/4.413
PWR1	24VDC Power Supply	069703	Power Supply, 24VDC 5A 110/230	1	+MAIN/2.207
Q1	Main Disconnect	050881-1	Disconnect, 63A 600V 3P 6mm Shaft	1	+MAIN/1.102
Q1	=	050908-1	Shaft, 290mm Pistol Grip Disconnect	1	+MAIN/1.102
Q1	=	050907-1	Handle, Disconnect Red/Yel Pistol Grip	1	+MAIN/1.102
R1	Main Control Relay	024890	Contacto, 9A 3P 24VDC Coil	1	+MAIN/2.217
R2	E-Stop Monitoring Relay	069883	Relay, 6A 24VDC w/ Cage Clamp Socket	1	+OP/7.714
SS1	Head Up/Down Switch	050545	Base, 2NO Contact	1	+MAIN/3.309
SS1	=	051744	Switch Operator, 3 Pos Sel Mom ZB4	1	+MAIN/3.309



Wood-Mizer®

Project Description: HR130EB15-1

Revision:	A6.02	Pg Desc:	Parts list
Mounting Location:	+Docs	Type:	Parts list
Prev. pg:	+OP/7	Page:	C1
Next pg:	D1	Total Pgs:	20

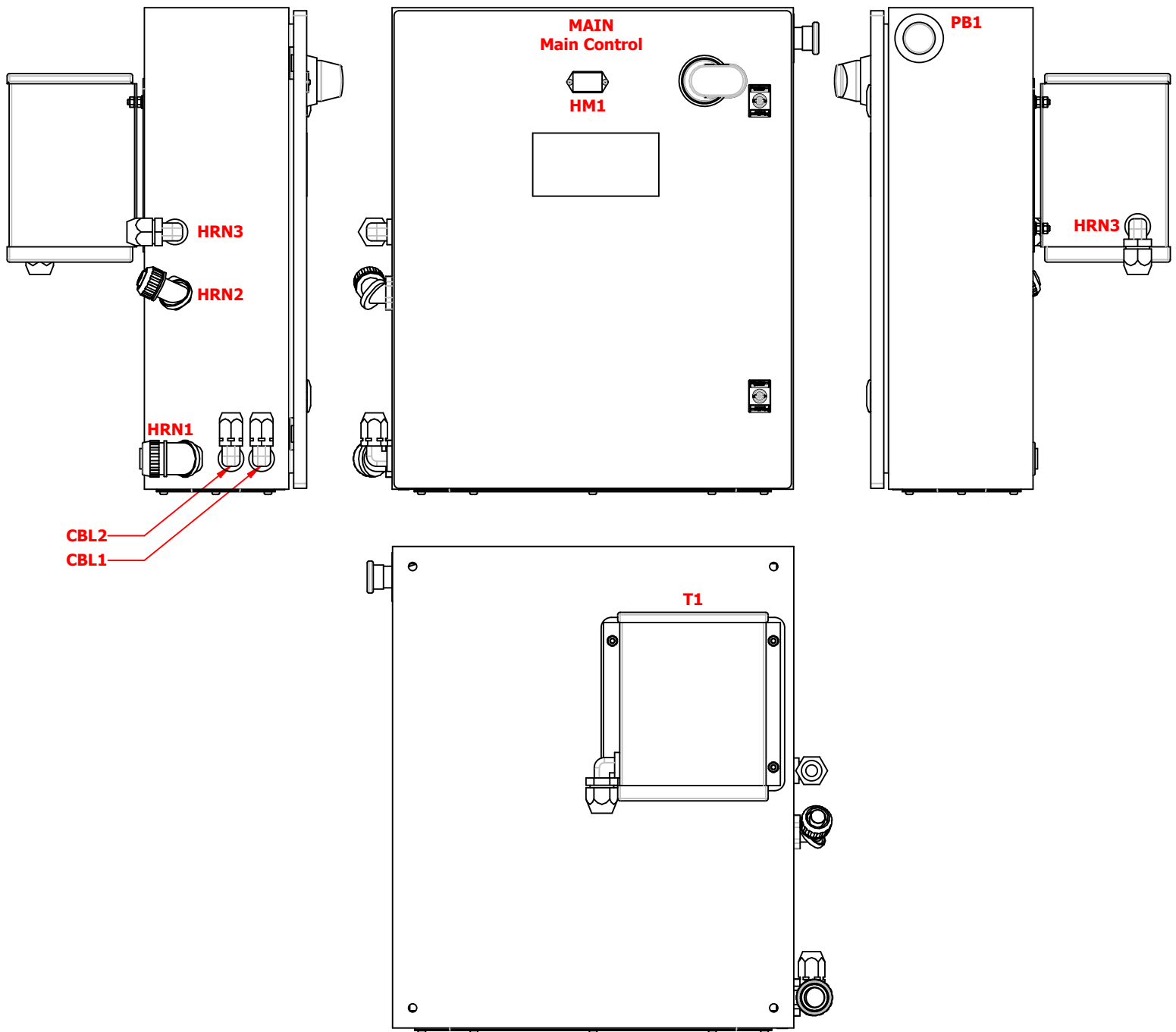

Wood-Mizer®

Project Description: HR130EC15-1

Revision:	A6.02	Pg Desc: Main Control Layout	
Mounting Location:	+Docs	Type: Panel layout	
Prev. pg:	E1	Page:	F1
		Next pg:	F2
		Total Pgs:	22

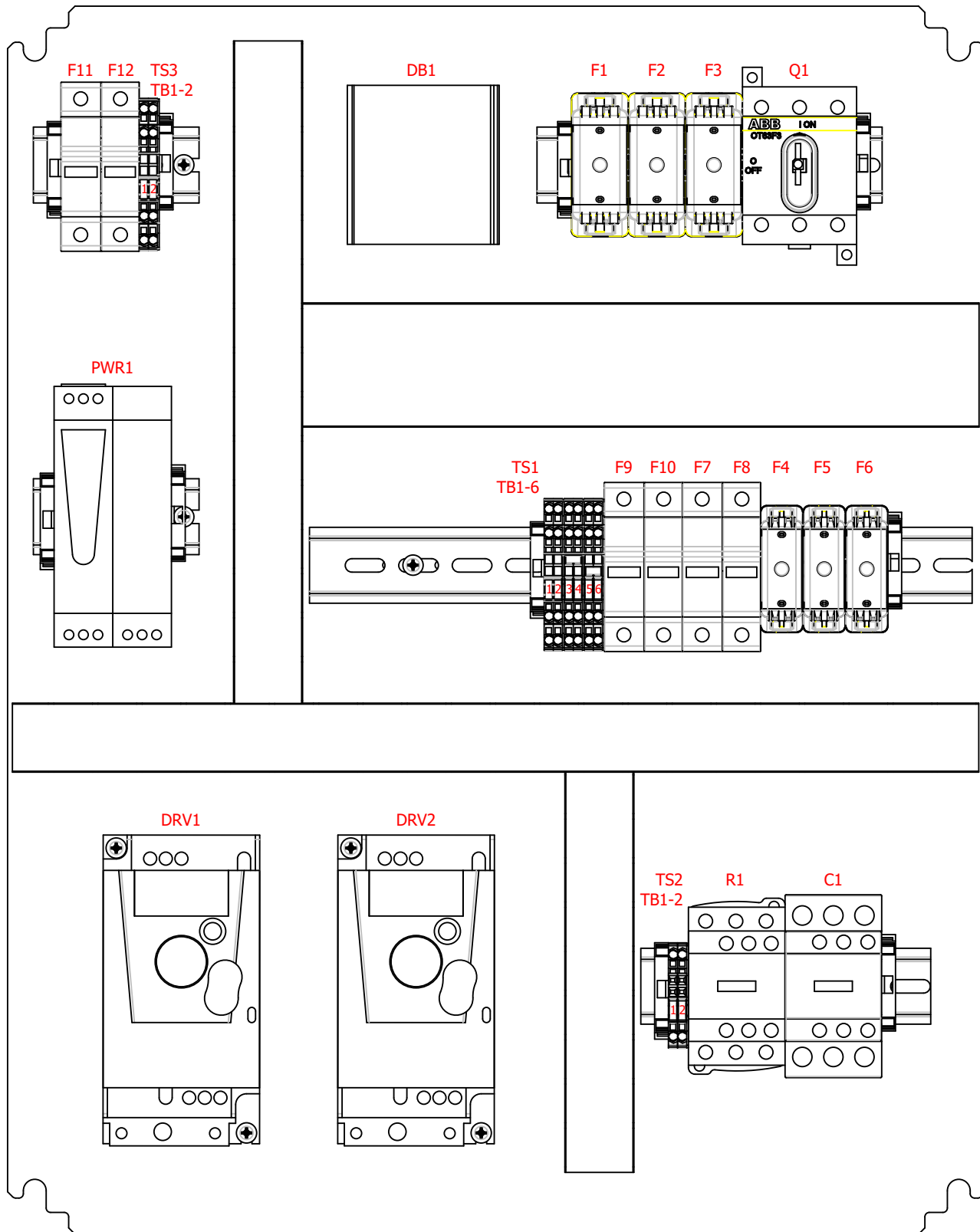

Wood-Mizer®

Project Description: HR130EC15-1

Revision: A6.02 Pg Desc: Main Control Insert Layout

Mounting Location: +Docs Type: Panel layout

Prev. pg: F1 Page: F2 Next pg: F3 Total Pgs: 22

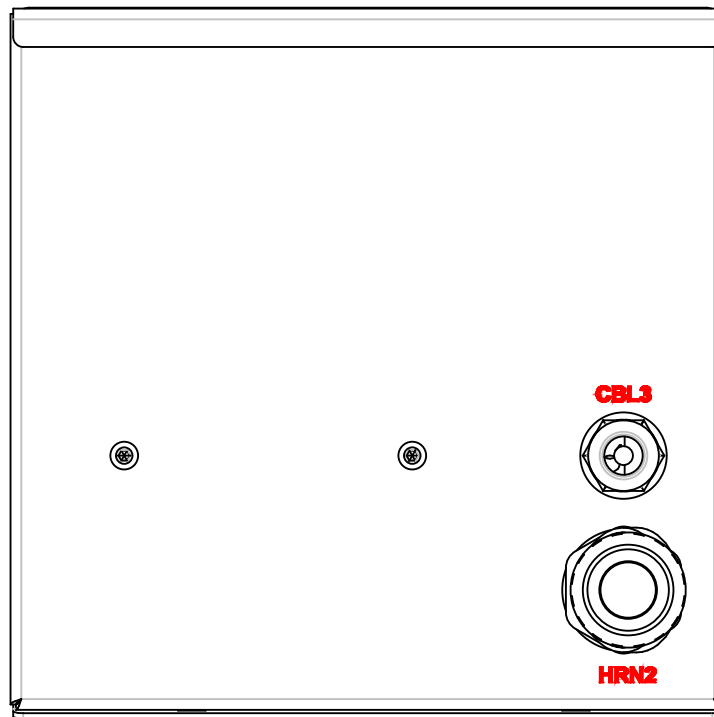
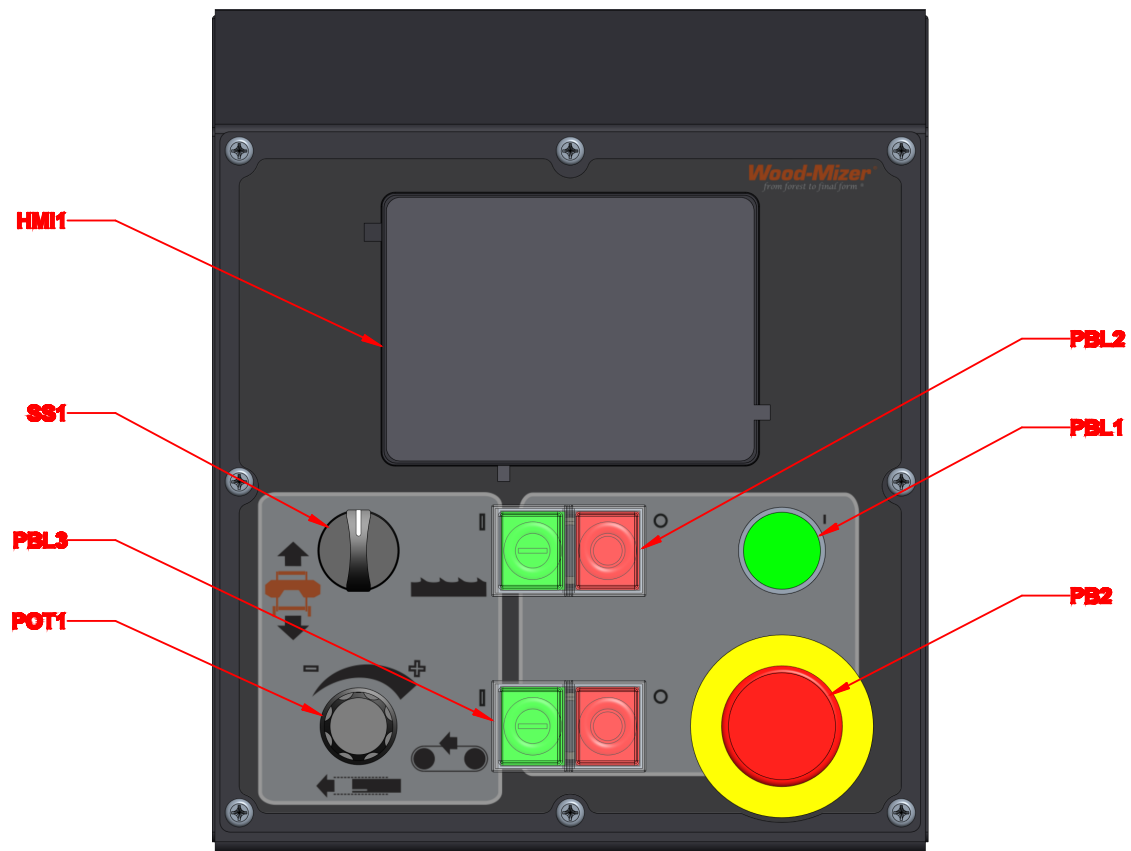

 Wood-Mizer®	
Project Description: HR130EC15-1	
Revision: A6.02	Pg Desc: Operator Layout
Mounting Location: +Docs	Type: Panel layout
Prev. pg: F2	Page: F3
Next pg: F4	Total Pgs: 22

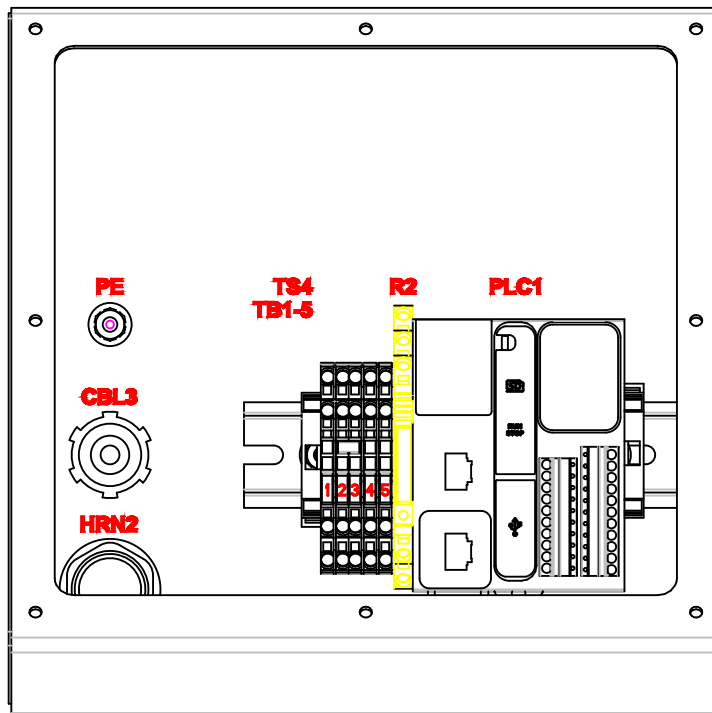
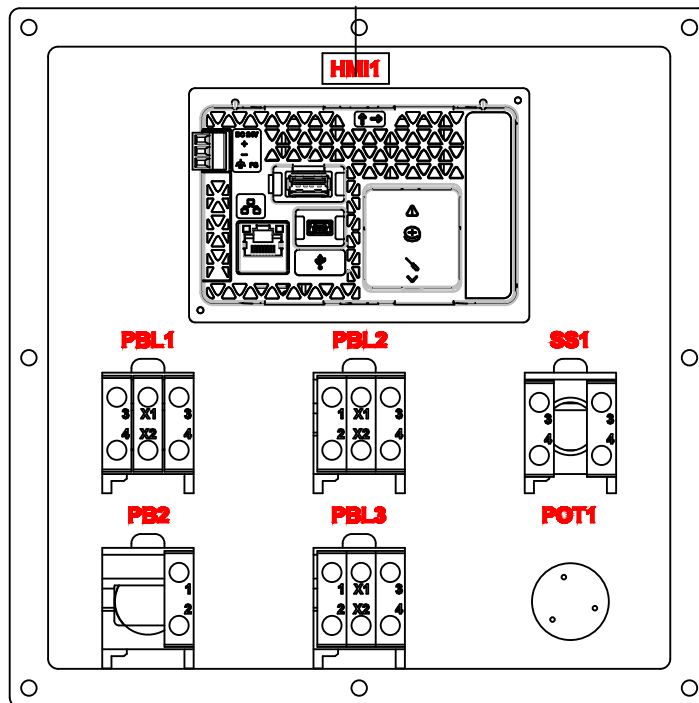

 Wood-Mizer®	
Project Description: HR130EC15-1	
Revision: A6.02	Pg Desc: Operator Layout Internal
Mounting Location: +Docs	Type: Panel layout
Prev. pg: F3	Page: F4
Next pg: F5	Total Pgs: 22

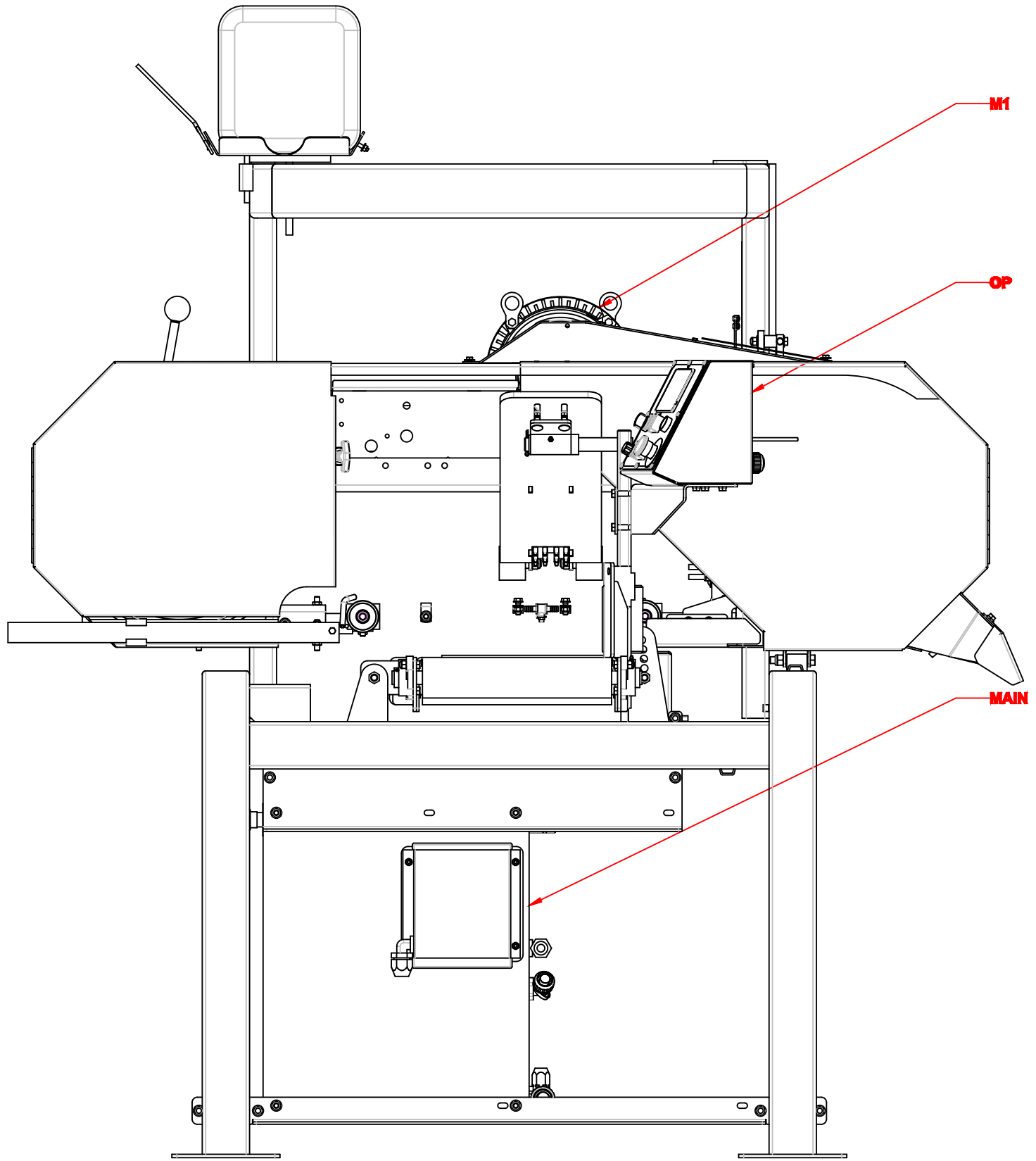

Wood-Mizer®

Project Description: HR130EC15-1

Revision:	A6.02	Pg Desc: Machine Front	
Mounting Location:	+Docs	Type: Panel layout	
Prev. pg:	F4	Page:	F5
		Next pg:	F6
		Total Pgs:	22

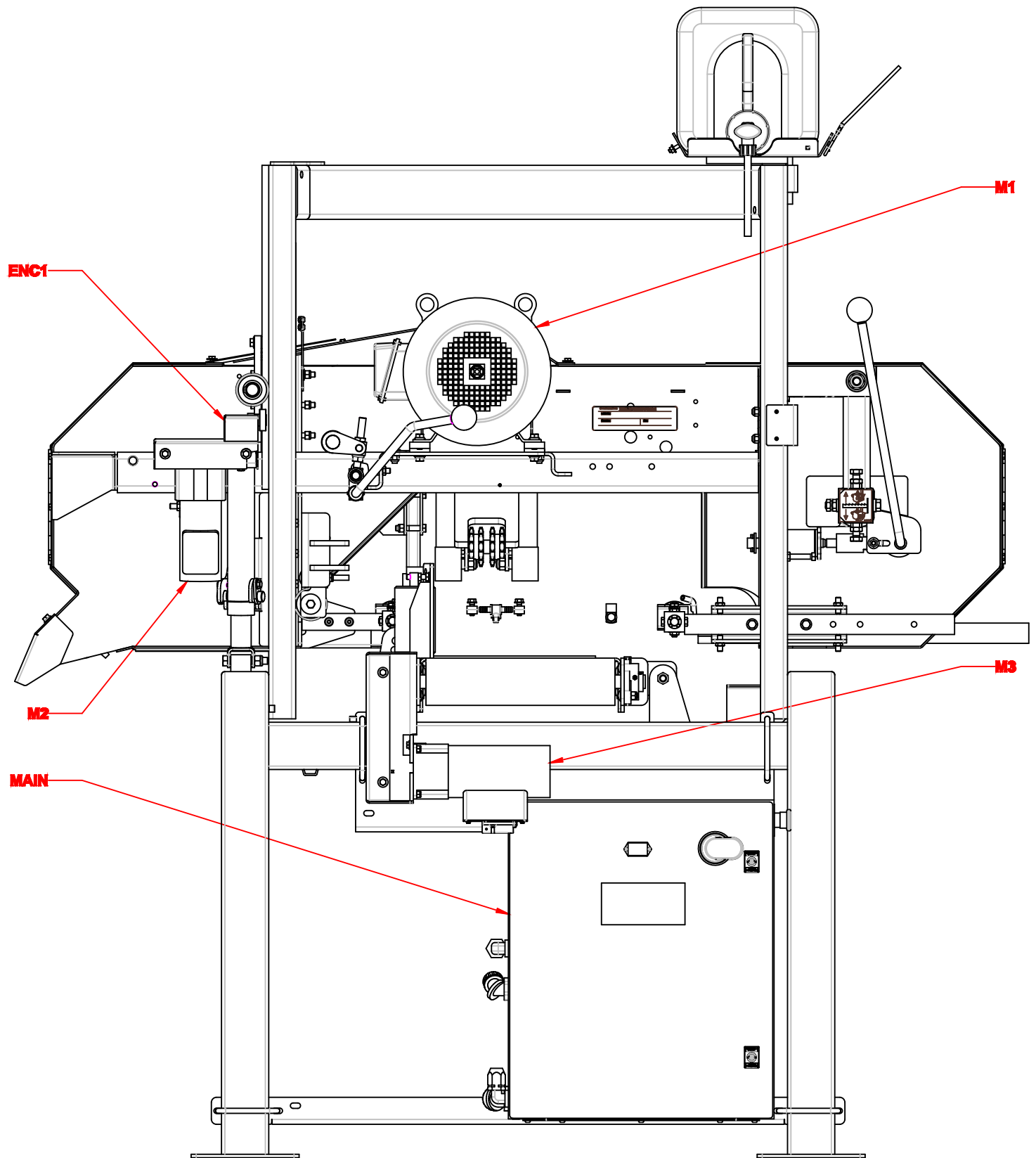



 Wood-Mizer®			
Project Description: HR130EC15-1			
Revision:	A6.02	Pg Desc: Machine Layout Back	
Mounting Location:	+Docs	Type: Panel layout	
Prev. pg:	F5	Page: F6	
		Next pg:	
		Total Pgs:	22

APPENDIX C ELECTRICAL INFORMATION

HR130EB15-1

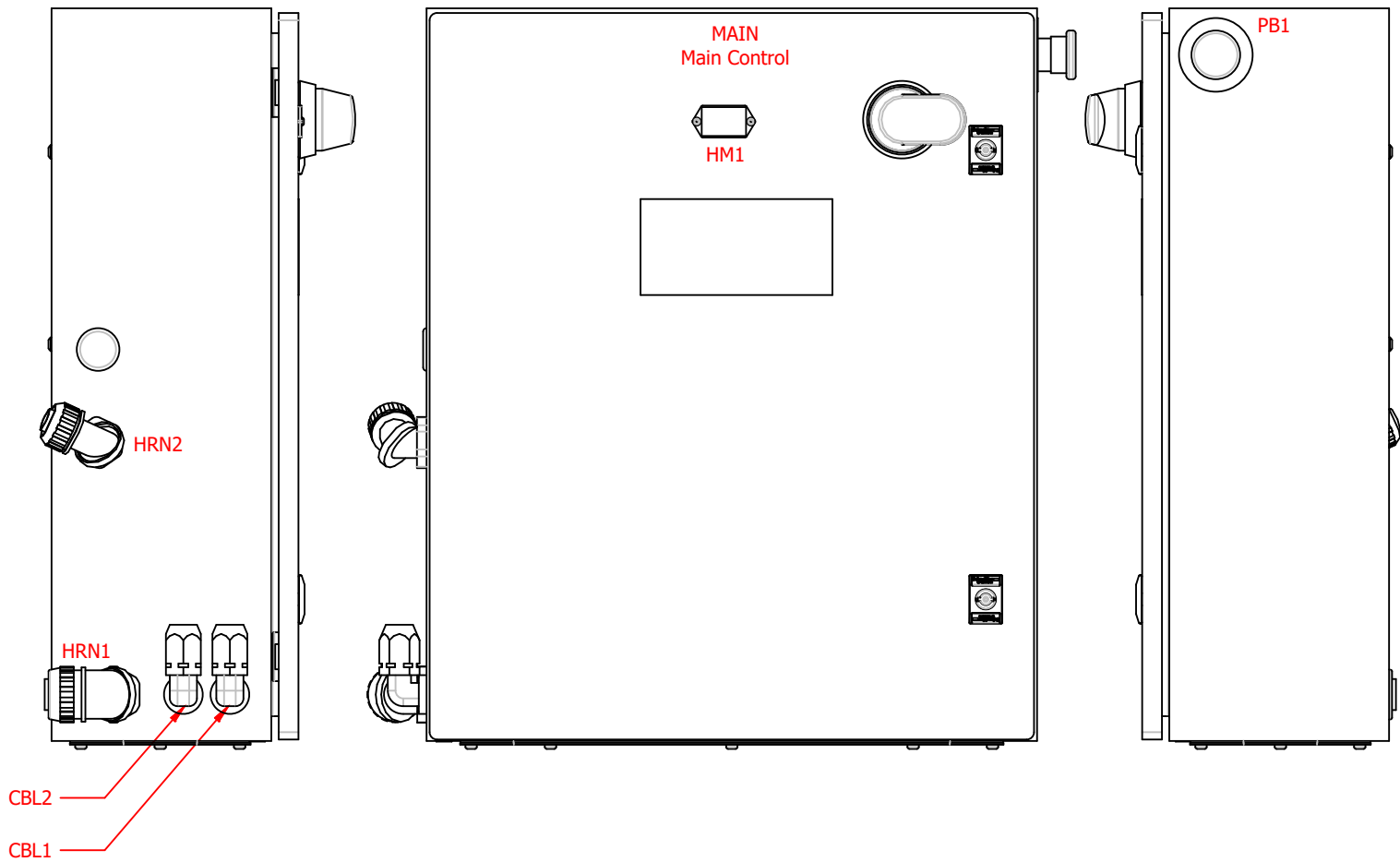
Rev. A6.05+



		Wood-Mizer®	
Project Description: HR130EB15-1			
Revision:	A6.02	Pg Desc: Main Control Layout	
Mounting Location:	+Docs	Type: Panel layout	
Prev. pg:	E1	Page:	F1
		Next pg:	F2
		Total Pgs:	20

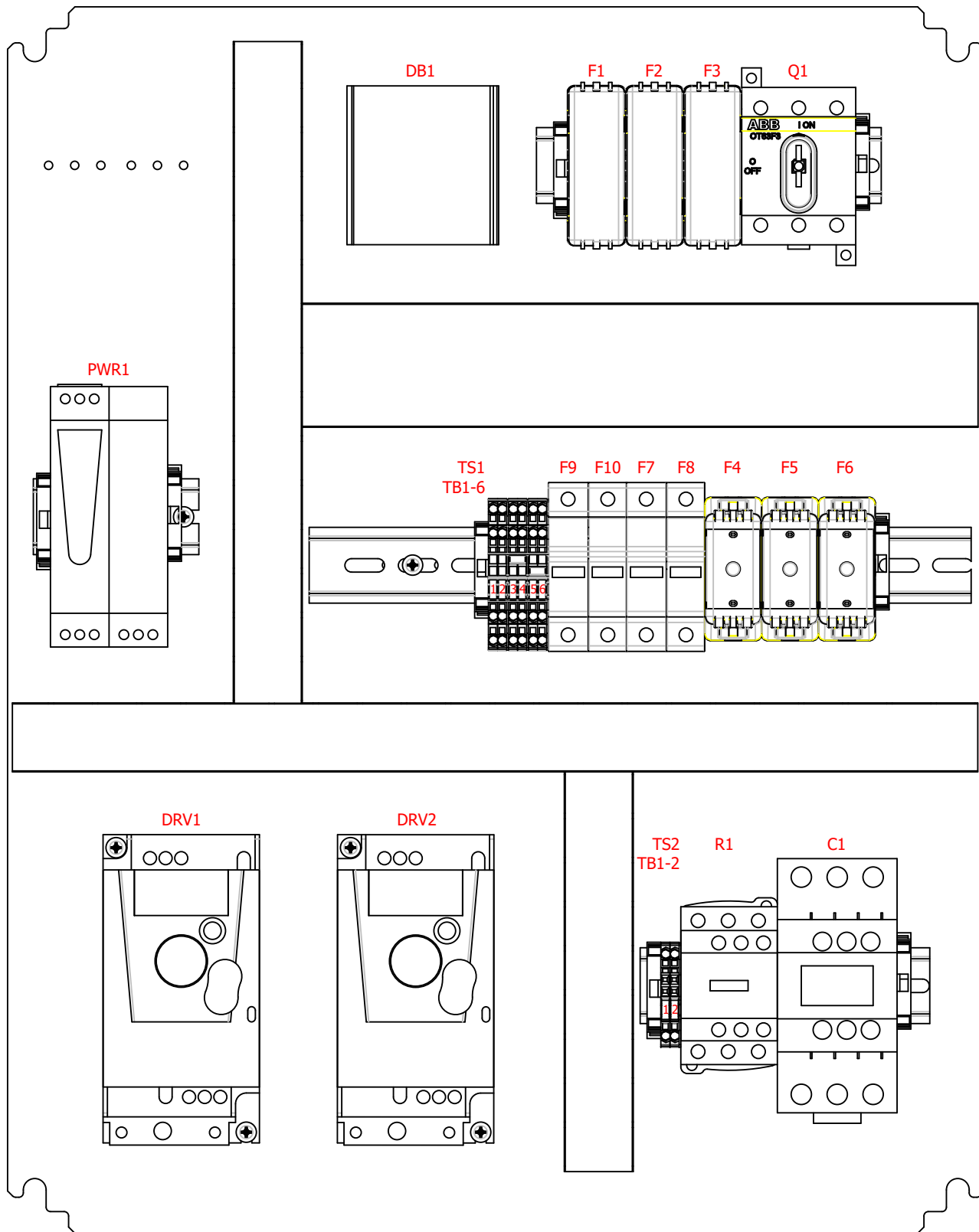

Wood-Mizer®

Project Description: HR130EB15-1

Revision: A6.02 Pg Desc: Main Control Insert Layout

Mounting Location: +Docs Type: Panel layout

Prev. pg: F1 Page: F2 Next pg: F3 Total Pgs: 20

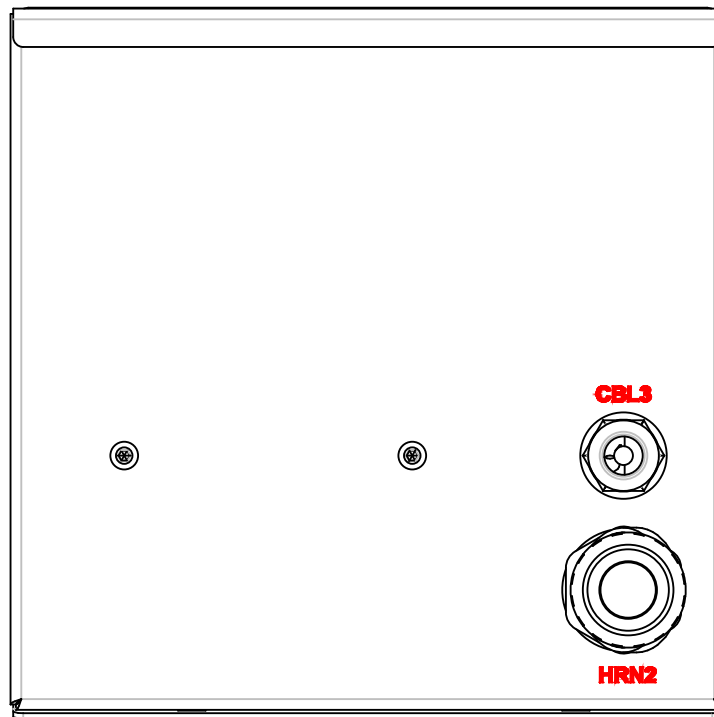
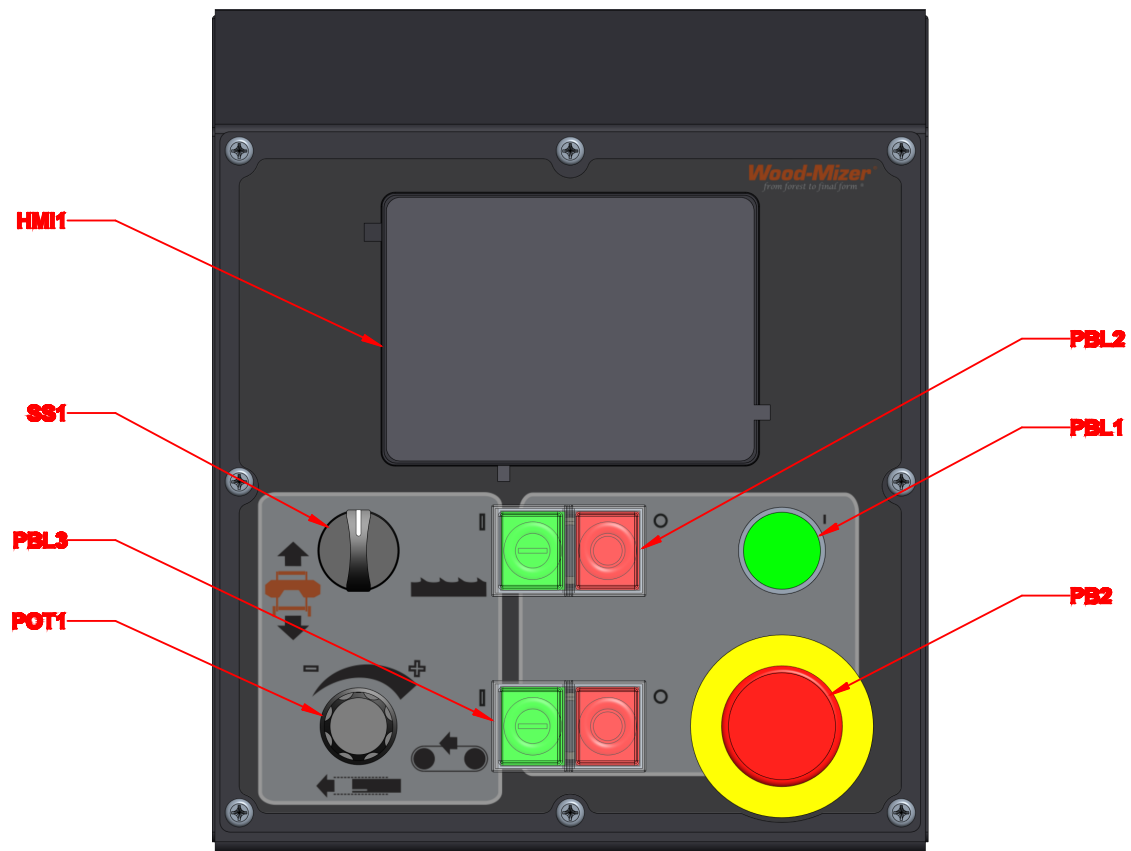

		Wood-Mizer®	
Project Description: HR130EB15-1			
Revision:	A6.02	Pg Desc: Operator Layout	
Mounting Location:	+Docs	Type: Panel layout	
Prev. pg:	F2	Page:	F3
		Next pg:	F4
		Total Pgs:	20

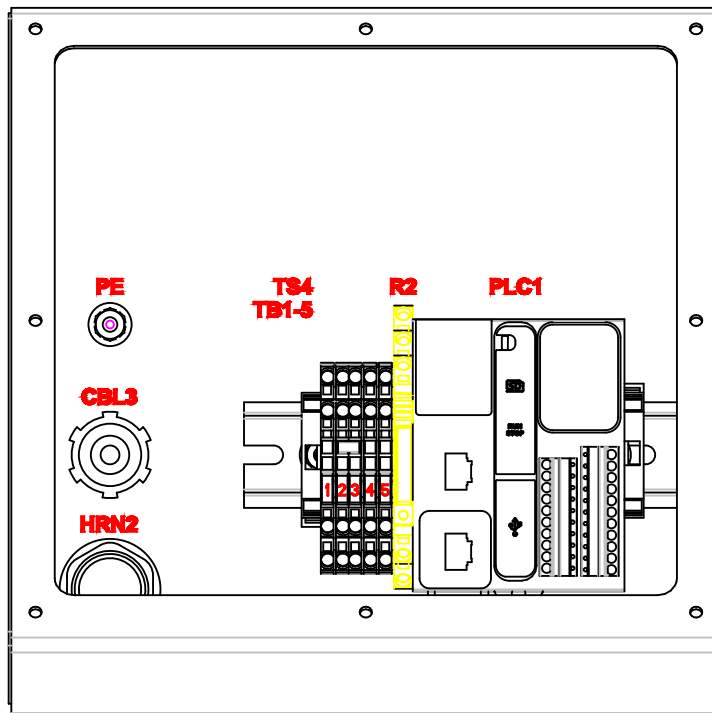
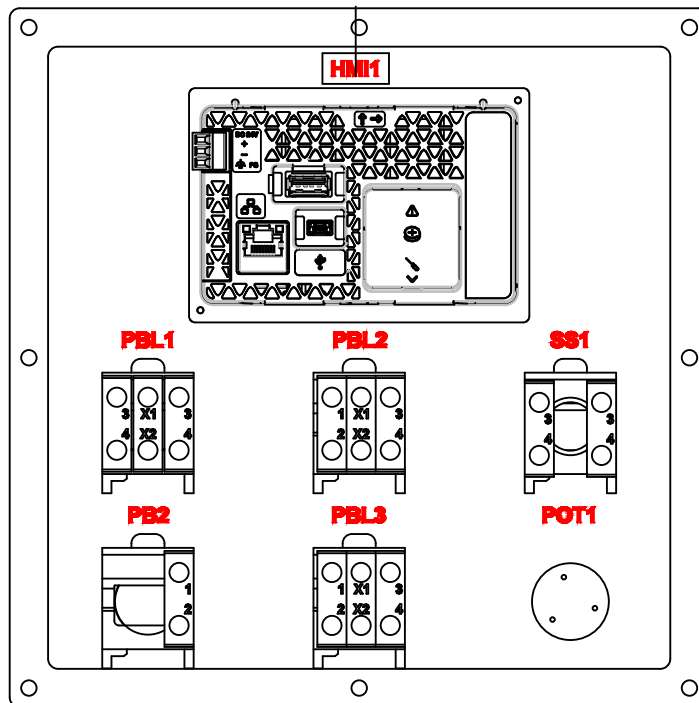

 Wood-Mizer®	
Project Description: HR130EB15-1	
Revision: A6.02	Pg Desc: Operator Layout Internal
Mounting Location: +Docs	Type: Panel layout
Prev. pg: F3	Page: F4
Next pg: F5	Total Pgs: 20

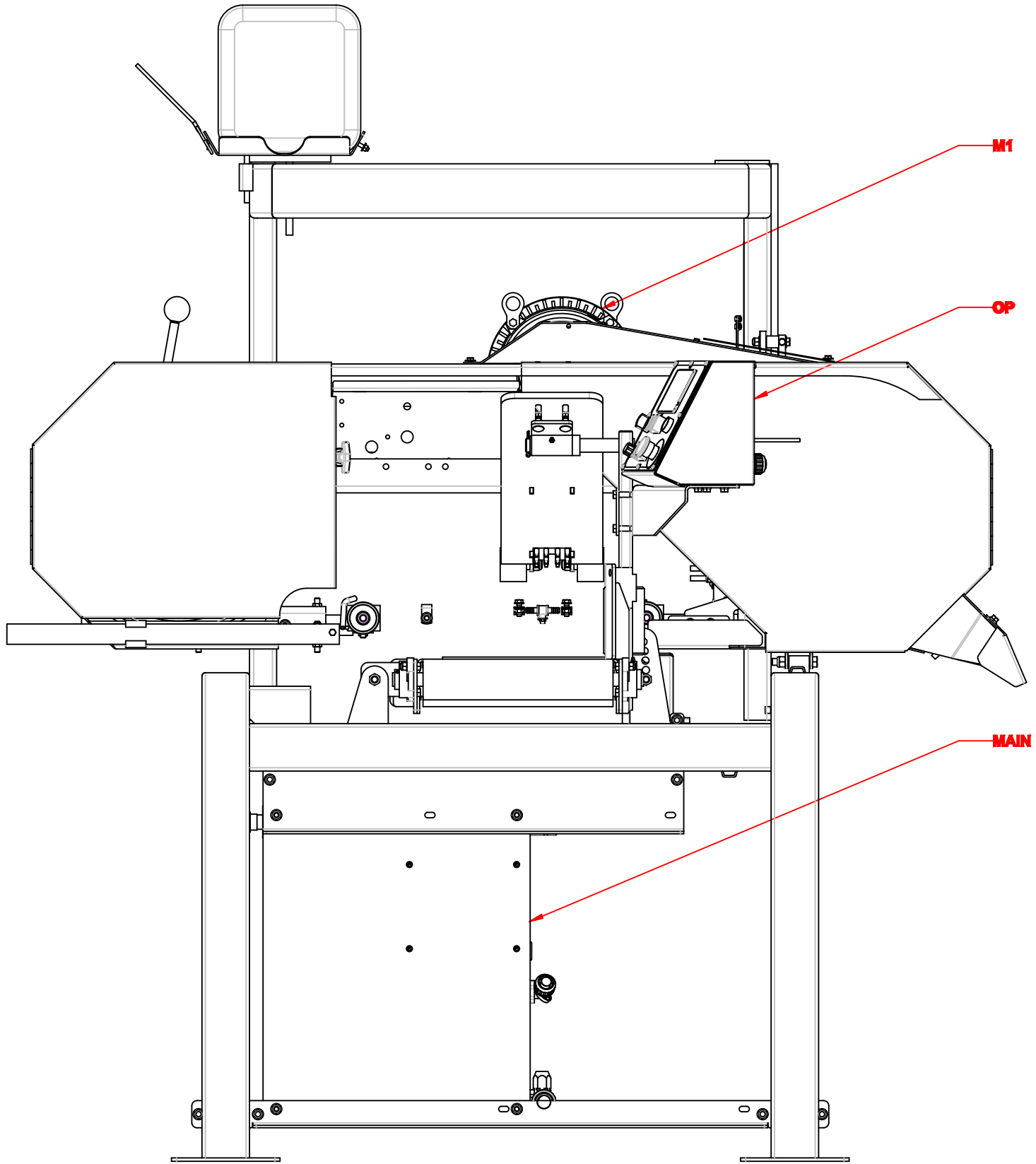

Wood-Mizer®

Project Description: HR130EB15-1

Revision:	A6.02	Pg Desc: Machine Layout Front	
Mounting Location:	+Docs	Type: Panel layout	
Prev. pg:	F4	Page:	F5
		Next pg:	F6
		Total Pgs:	20

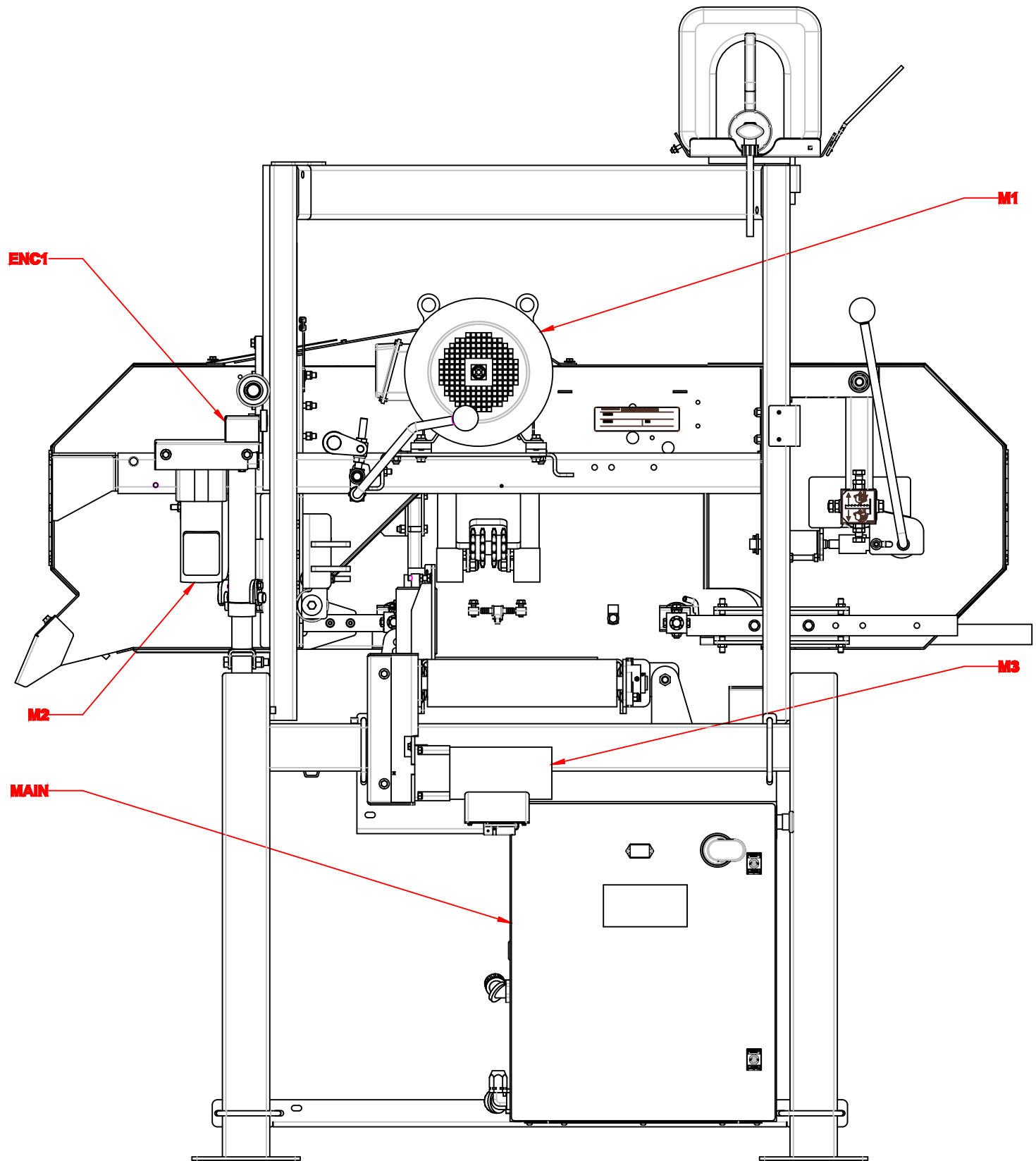

Wood-Mizer®

Project Description: HR130EB15-1

Revision:	A6.02	Pg Desc:	Machine Layout Back
Mounting Location:	+Docs	Type:	Panel layout
Prev. pg:	F5	Page:	F6
		Next pg:	Total Pgs: 20