

Wood-Mizer® HR130 Resaw
Safety, Operation, &
Maintenance Manual

HR130

rev. A6.04

Safety is our #1 concern!

Form #2675



WARNING! Read and understand this manual before using this machine.

California

Proposition 65 Warning



WARNING: Breathing gas/diesel engine exhaust exposes you to chemicals known to the State of California to cause cancer and birth defects or other reproductive harm.

Always start and operate the engine in a well-ventilated area.
If in an enclosed area, vent the exhaust to the outside.
Do not modify or tamper with the exhaust system.
Do not idle the engine except as necessary.

For more information go to www.P65warnings.ca.gov.



WARNING: Drilling, sawing, sanding or machining wood products can expose you to wood dust, a substance known to the State of California to cause cancer. Avoid inhaling wood dust or use a dust mask or other safeguards for personal protection.

For more information go to www.P65Warnings.ca.gov/wood.

Active Patents assigned to Wood-Mizer, LLC

Wood-Mizer, LLC has received patents that protect our inventions which are a result of a dedication to research, innovation, development, and design. Learn more at: woodmizer.com/patents

©2025 Wood-Mizer LLC

Printed in the United States of America, all rights reserved. No part of this manual may be reproduced in any form by any photographic, electronic, mechanical or other means or used in any information storage and retrieval system without written permission from

Wood-Mizer, LLC
8180 West 10th Street
Indianapolis, Indiana 46214

SECTION 1 INTRODUCTION

1.1 About This Manual 1-3
1.2 Getting Service..... 1-3
1.3 Specifications 1-3

SECTION 2 GENERAL SAFETY

2.1 Safety Symbols 2-1
2.2 Safety Instructions..... 2-1
2.3 Safety Labels Description 2-3

SECTION 3 SETUP

3.1 Resaw Setup 3-1
3.2 Electrical Installation (HR130 E15 Only)..... 3-2
3.3 Upper Hold-Down Adjustment 3-4
3.4 Blade Guide Arm Adjustment..... 3-5
3.5 Conveyor Tilt Adjustment 3-6
3.6 Shingle Belt Installation (Optional) 3-7
3.7 Tensioning The Blade 3-8
3.8 Replacing The Blade..... 3-9
3.9 Tracking The Blade..... 3-10
3.10 Table Setup (Optional)..... 3-12

SECTION 4 OPERATION

4.1 Up/Down Operation..... 4-1
4.2 Machine Start 4-3
4.3 Clutch Operation 4-4
4.4 Feed Operation..... 4-5
4.5 Water Lube Operation..... 4-6
4.6 Shingle Belt Operation (Optional) 4-8

SECTION 5 MAINTENANCE

5.1 Blade Guides 5-1
5.2 Sawdust Removal..... 5-2
5.3 Vertical Mast Rails..... 5-3
5.4 Blade Wheel Belts..... 5-4
5.5 Feed System 5-5
5.6 Battery Replacement - M221 PLC..... 5-6

SECTION 6 ALIGNMENT

6.1 Complete Alignment Procedure..... 6-1

SECTION 7 ELECTRICAL INFORMATION

Wood-Mizer® LLC
Limited Product Warranty



Wood-Mizer LLC (“Warrantor”), an Indiana corporation with its principal place of business at 8180 West Tenth Street, Indianapolis, IN 46214-2400 USA, warrants to the purchaser (“Purchaser”) that for the time periods specifically stated herein and subject to the terms, conditions and limitations stated herein, the equipment manufactured by the Warrantor will be free from defects in material and workmanship attributable to Warrantor so long as, during the warranty periods stated herein, the equipment is installed, operated and maintained in accordance with the instructions provided by Warrantor.

PRODUCT	MODEL CLASS	LENGTH OF WARRANTY		EFFECTIVE DATE
		USA & CANADA	NON USA & CANADA	
Portable Sawmills, Resaws, Edgers	LT, LX, HR, EG	Two years	One year	Date of purchase
Portable Sawmills with Chassis	LT28, LT35, LT40, LT50, LT70, LX450	Two years, excluding the chassis, which chassis shall have a five year warranty	One year	
Industrial Sawmills, Resaws, Edgers	WM, HR, EG, TVS, SVS	One year	One year	Date of purchase or date of installation / training (if applicable), whichever occurs first, not to exceed 6 months from date of purchase
TITAN Industrial	WB, TV, HR, EG, EA, MR	One year	One year	
Material Handling	TWC, IC, TD, LD, GC, CR, CB, CC	One year	One year	
Blade Maintenance Equipment	BMS, BMT, BMST	One year	One year	Date of purchase
Options and Accessories	Various	One year*	One year*	
Moulders, Extractors, Kilns	MP, MD, KS, KD	One year	One year	
Slab Flatteners	MB	Two years	One year	
Pallet Equipment	PD, PC	One year	One year	
Log Splitters	FS	One year	One year	
Replacement Parts	Various	90 days	90 days	

* Warranty on Options will match the warranty on the primary equipment when purchased on same invoice.

Exclusions from 90 Day, Limited One Year and Two Year Warranty

Warrantor shall have no responsibility under this warranty for any wear components, including, but not limited to: belts, blade guides, blades, electric motor brushes, drum switches, filters, fuses, hoses, bearings (excluding cylindrical drive bearings), bushings, cable carriers, and spark plugs. All wear components are furnished “as is”, without any warranty from Warrantor. This limited warranty does not cover any defects caused by misuse, negligence, alterations, damage due to overload, abnormal conditions, excessive operation, accident, or lack of performance of normal maintenance services.

Several components which are used in the manufacture of the equipment but not manufactured by Warrantor such as cant hooks, power plants, laser sights, batteries, tires, and trailer axles have warranties provided by the original equipment manufacturer (written copies available upon request). Warrantor does not separately warrant such items. Components or equipment manufactured by third parties are not covered by this warranty. Warrantor, however, will provide reasonable assistance to the Purchaser to make claims against any warranties applicable to such component parts as provided by such original equipment manufacturers. Components or equipment manufactured by third parties are not covered by this Warranty.

Five Year Limited Chassis Warranty

The limited five year chassis warranty described above, DOES NOT extend to (a) any damage stemming from accident, improper towing, overload, abuse, misuse, abnormal conditions, negligence, excessive operation, or lack of maintenance, (b) rust caused by exposure to corrosive atmospheric conditions, or (c) the sawmill head, carriage, axle, brakes, or any hydraulic or electrical components attached to the chassis.

Warrantor’s Obligations as To Defects

In the event that the equipment fails to perform due to defective materials or workmanship attributable to Warrantor under normal use and service within the established warranty period, Purchaser’s sole and exclusive remedy and Warrantor’s sole liability shall be to replace or repair, in Warrantor’s sole and subjective discretion, any defective part at Warrantor’s principal place of business without cost to the Purchaser if such defect exists. The determination of whether a product is defective shall be made by Warrantor in Warrantor’s sole and subjective discretion. The Purchaser must notify Warrantor prior to shipping any defective part. Warrantor, at its sole discretion, may cover expenses incurred in shipping the defective part to Warrantor for evaluation; provided, however, that Warrantor will not be responsible for labor, travel time, mileage, removal, installation or incidental or consequential damages. However, any part in excess of 140 pounds must be returned by the Purchaser, to the Warrantor’s nearest authorized facility at the Purchaser’s expense, if return is requested by Warrantor. Warrantor shall have a reasonable time within which to replace or repair the defective part. If Warrantor determines that the product is not defective under the terms of this warranty in Warrantor’s sole and subjective discretion, then Purchaser shall be responsible for any expenses incurred by Warrantor in returning the equipment to the Purchaser.

Limitations and Disclaimers of Other Warranties

EXCEPT FOR THE EXPRESS WARRANTY PROVISIONS STATED ABOVE, WARRANTOR DISCLAIMS ALL WARRANTIES, EXPRESS AND/OR IMPLIED, INCLUDING WITHOUT LIMITATION, THE IMPLIED WARRANTIES OF MERCHANTABILITY, AND FITNESS FOR A PARTICULAR PURPOSE, NONINFRINGEMENT AND TITLE. No representation or other affirmation of fact by representatives of Warrantor, whether verbal or in writing, including photographs, brochures, samples, models, or other sales aids, shall constitute a warranty or other basis for any legal action against Warrantor. There are no other representations, promises, agreements, covenants, warranties, guarantees, stipulations or conditions, express or implied, by Warrantor except as expressly set forth herein. THE ORIGINAL PURCHASER AND ANY INTENDED USER OR BENEFICIARY OF THIS EQUIPMENT, SHALL NOT BE ENTITLED TO RECOVER ANY INDIRECT, SPECIAL, PUNITIVE, EXEMPLARY, CONSEQUENTIAL, SPECIAL, OR INCIDENTAL DAMAGES OR LOSSES, INCLUDING BUT NOT LIMITED TO, DAMAGES OF LOST PRODUCTION, LOST REVENUE, LOST PRODUCT, LOST PROFITS, LOST BUSINESS, LOSS OF USE, LOSS OF GOODWILL, OR BUSINESS INTERRUPTION, FROM WARRANTOR FOR ANY REASON WHATSOEVER INCLUDING WITHOUT LIMITATION WARRANTY OR DEFECT IN THE PRODUCT REGARDLESS OF THE SOLE, JOINT AND/OR CONCURRENT NEGLIGENCE, BREACH OF CONTRACT, BREACH OF WARRANTY, STRICT LIABILITY IN TORT OR STATUTORY CLAIMS OR OTHER LEGAL FAULT OR RESPONSIBILITY OF EITHER WARRANTOR OR PURCHASER OR ITS EMPLOYEES OR AGENTS. Warrantor does not warrant that its equipment meets or complies with the requirements of any particular safety code or governmental requirements.

Defective items replaced under the terms of this warranty become the property of Warrantor.

Design Changes

Warrantor reserves the right to change the design of its products from time to time without notice and without obligation to make corresponding changes in or to its products previously manufactured.

Rights of Purchasers

The validity and effect of this limited warranty as well as its interpretation, operation and effect, shall be determined exclusively by the principles of law and equity of the State of Indiana, USA. This limited warranty gives Purchaser specific legal rights. Purchaser may also have other rights, which may vary from state to state. Some states may not allow limitations as to the duration of implied warranties or to the exclusion or limitation of incidental or consequential damages, so some of the limitations and exclusions detailed set forth above may not apply. In the event that any one or more of the provisions of this warranty shall be or become invalid, illegal or unenforceable in any respect, the validity, legality and enforceability of the remaining provisions of this warranty shall not be affected thereby.

Interpretations

This Warranty constitutes the entire warranty agreement between Warrantor and Purchaser and supersedes any prior understandings or agreements pertaining to the same subject matter. This warranty cannot be amended except in writing which refers to this warranty which is signed by both Warrantor and Purchaser.

YOUR WARRANTY RIGHTS AND OBLIGATIONS

The U.S. EPA, and Wood-Mizer, LLC (Wood-Mizer), are pleased to explain the emission control system's warranty on your 2026 model year small off-road equipment. Wood-Mizer must warrant the evaporative emission control system on your certified equipment model for the period listed below provided there has been no abuse, neglect or improper maintenance of your equipment leading to the failure of the evaporative emission control system.

Your evaporative emission control system may include parts such as: carburetors, fuel tanks, fuel lines (for liquid fuel and fuel vapors), fuel caps, valves, canisters, filters, clamps, connectors, and other associated components.

MANUFACTURER'S WARRANTY COVERAGE

This evaporative emission control system is warranted for two years for U.S. customers. If any evaporative emission-related part on your equipment is defective, the part will be repaired or replaced by Wood-Mizer.

OWNER'S WARRANTY RESPONSIBILITIES

As the certified equipment model owner, you are responsible for the performance of the required maintenance listed in your owner's manual. Wood-Mizer recommends that you retain all receipts covering maintenance on your equipment, but Wood-Mizer cannot deny warranty coverage solely for the lack of receipts.

As the certified equipment model owner, you should be aware that Wood-Mizer may deny you warranty coverage if your equipment or a part has failed due to abuse, neglect, or improper maintenance or unapproved modifications.

You are responsible for presenting your certified equipment model to a Wood-Mizer location as soon as the problem exists. The approved warranty repairs shall be completed in a reasonable amount of time. If you have any questions regarding your warranty coverage, contact Wood-Mizer LLC by signing into your account on <https://woodmizer.com>, or call: 1-800-525-8100.

EMISSION WARRANTY PARTS LIST	
Fuel Tank	Vacuum Control Diaphragms*
Fuel Cap	Control Cables*
Fuel Lines (for liquid fuel and fuel vapors)	Control Linkages*
Fuel Line Fittings	Purge Valves*
Clamps*	Gaskets*
Pressure Relief Valves*	Liquid/Vapor Separator
Control Valves*	Carbon Canister
Control Solenoids*	Canister Mounting Brackets
Electronic Controls*	Carburetor Purge Port Connector

*NOTE: As they relate to the evaporative emission control system.

SECTION 1 INTRODUCTION

1.1 About This Manual

This manual replaces any previous information received on your Wood-Mizer[®] equipment.

The information and instructions in this manual do not amend or extend the limited warranties for the equipment given at the time of purchase.

1.2 Getting Service

For contact information, sales, service, parts, and additional manuals, sign into your account on <https://woodmizer.com>, or call inside the USA: 1-800-553-0182 or from outside the USA: 317-271-1542

1.3 Specifications

Equipment specification are included in the Online Manuals, which are found at <https://apps.woodmizer.com/Manuals/Manuals.aspx?parent=0>.

SECTION 2 GENERAL SAFETY

2.1 Safety Symbols

The following symbols and signal words call your attention to instructions concerning your personal safety. Be sure to observe and follow these instructions.

 **DANGER!** Indicates an imminently hazardous situation which, if not avoided, will result in serious injury or death.

 **WARNING!** Suggests a potentially hazardous situation which, if not avoided, could result in serious injury or death.

 **CAUTION!** Refers to potentially hazardous situations which, if not avoided, may result in minor or moderate injury or damage to equipment.

NOTICE Indicates vital information.

2.2 Safety Instructions

OWNER/OPERATOR'S RESPONSIBILITY

The procedures listed in this manual may not include all ANSI, OSHA, or locally required safety procedures. **It is the owner/operator's responsibility and not Wood-Mizer LLC to ensure all operators are properly trained and informed of all safety protocols.** Owner/Operators are responsible for following all safety procedures when operating and performing maintenance to the equipment.

OBSERVE ALL SAFETY INSTRUCTIONS

NOTICE Read the entire Operator's Manual before operating this equipment.

Note all safety warnings throughout this manual and those posted on the machine.

Be able to access this manual at all times while operating this equipment.

Read additional manufacturer's manuals and observe their applicable safety instructions.

Only persons who have read and understood the entire operator's manual should operate this equipment.

This equipment is not intended for use by or around children.

It is the owner/operator's responsibility to comply with all applicable federal, state, and local laws, rules, and regulations regarding the ownership, operation, and transporting your equipment.

Operators should become thoroughly familiar with and comply with these applicable laws for operating and transporting equipment.

 **WARNING!** Clean sawdust from all guards, vents, control boxes, or any area where sawdust may gather **after every shift.** Failure to

do so may result in fire, causing death or serious injury.

WEAR SAFETY CLOTHING

 **WARNING!** Secure all loose clothing and jewelry before operating the equipment.

Always wear eye, ear, and foot protection when operating or servicing the equipment.



Wear hand protection while servicing the equipment blades.



Wear respiratory protection when sawing woods that require it.



HANDLE FUEL/LUBRICANTS SAFELY

 **WARNING!** Do not use flammable fuels or liquids such as diesel fuel. Use **ONLY** water and Wood-Mizer Lube Additive with the water lube accessory.

EQUIPMENT SETUP

 **DANGER!** Do not operate the equipment without **all** covers and guards in place.

 **WARNING!** Set up the equipment on solid, level ground.

CHECK EQUIPMENT BEFORE OPERATION

 **DANGER!** Ensure all guards and covers are in place and secured before operating the equipment.

KEEP PERSONS AWAY

 **DANGER!** Keep all persons out of the path of moving equipment and lumber when operating equipment or loading lumber.

Ensure the blade is disengaged and all persons are out of the path of the blade before starting the motor.

KEEP HANDS AWAY

 **DANGER!** Remove power before clearing debris or any other maintenance activity.

 **WARNING!** Avoid contact with any hot parts (motors).

Allow the system to cool sufficiently before beginning any service function, including debris removal.

Avoid contact with sharp edges of the blades.

Stay a safe distance from rotating members (shafts, pulleys, fans, etc.) and ensure loose clothing or long hair does not engage rotating members

Do not adjust the motor drive belt with the motor running.

Keep hands, feet, etc., clear of exiting saw-dust chute when operating equipment.

UP/DOWN SYSTEM SAFETY



WARNING! If maintenance is required, support load of saw head on each side.

KEEP SAFETY LABELS IN GOOD CONDITION

NOTICE Ensure that all safety decals are clean and readable. Replace all damaged safety decals to prevent personal injury or damage to the equipment. Contact your local distributor, or call your Customer Service Representative to order more decals.

NOTICE If replacing a component that has a safety decal affixed to it, ensure the new component also has the safety decal affixed in the same place.

KEEP RESAW AND AREA AROUND RESAW CLEAN



WARNING! Maintain a clean and clear path for all necessary movement around the resaw and material stacking areas.

Do not allow children in the area of the resaw.

DISPOSE OF WOOD BY-PRODUCTS PROPERLY

NOTICE Properly dispose of all wood by-products, including sawdust, chips, and other debris, including operation waste such as oil, filters, etc.

MAINTENANCE HAZARDS INCLUDE, BUT NOT LIMITED TO:

- Blade contact
- Pinch points
- Kickbacks
- Missiles (thrown blades/wood chips)
- Electrical

FAILURE TO LOCKOUT MAY RESULT IN, BUT NOT LIMITED TO:

- Cut
- Crush
- Blindness
- Puncture
- Electrocution

- Serious injury and death
- Amputation
- Burn
- Shock

TO CONTROL MAINTENANCE DANGERS:

- Lockout procedures must be followed (see **OSHA regulation 1910.147**).
- Never rely on machine stop control for maintenance safety (emergency stops, on/off buttons, interlocks).
- Do not reach into moving blades or feed systems. Allow all coasting parts to come to a complete stop.
- Electrical power supply and air supply must both be locked out.
- Where established lockout procedures cannot be used (electrical troubleshooting or mechanical dynamic troubleshooting), alternative effective protective techniques shall be employed which may require special skills and planning.
- Always follow safe operations practices in the workplace.

EQUIPMENT LOCKOUT PROCEDURE

Lockout procedures per OSHA regulation 1910.147, appendix A:

GENERAL

The following simple lockout procedure is provided to assist owner/operators in developing their procedures so they meet the requirements of **OSHA regulation 1910.147**. When the energy isolating devices are not lockable, tagout may be used, provided the owner/operator complies with the provisions of the standard which require additional training and more rigorous periodic inspections. When tagout is used and the energy isolating devices are lockable, the owner/operator must provide full operator protection (see OSHA regulation 1910.147, paragraph (c)(3)) and additional training and more rigorous periodic inspections are required. For more complex systems, more comprehensive procedures may need to be developed, documented, and utilized.

PURPOSE

This procedure establishes the minimum requirements for the lockout of energy isolating devices whenever maintenance or servicing is done on machines or equipment. It shall be used to ensure that the machine or equipment is stopped, isolated from all potentially hazardous energy sources and locked out before personnel perform any servicing or maintenance where the unexpected energization or start-up of the machine or equipment or release of stored energy could cause injury.

COMPLIANCE WITH THIS PROGRAM

All personnel are required to comply with the restrictions and limitations imposed upon them during the use of lockout. The authorized personnel are required to perform the lockout in accordance with this procedure. All operators, upon observing a machine or piece of equipment which is locked out to perform servicing or maintenance shall not

attempt to start, energize, or use that machine or equipment.

SEQUENCE OF LOCKOUT

1. Notify all affected personnel that servicing or maintenance is required on a machine or equipment and that the machine or equipment must be shut down and locked out to perform the servicing or maintenance.
2. The authorized employee shall refer to the company procedure to identify the type and magnitude of the energy that the machine or equipment utilizes, shall understand the hazards of the energy, and shall know the methods to control the energy.
3. If the machine or equipment is operating, shut it down by the normal stopping procedure (depress the stop button, open switch, close valve, etc.).
4. De-activate the energy isolating device(s) so that the machine or equipment is isolated from the energy source(s).
5. Lock out the energy isolating device(s) with assigned individual lock(s).
6. Stored or residual energy (such as that in capacitors, springs, elevated machine members, rotating fly-wheels, hydraulic systems, and air, gas, steam, or water pressure, etc.) must be dissipated or restrained by methods such as grounding, repositioning, blocking, bleeding down, etc.
7. Ensure that the equipment is disconnected from the energy source(s) by first checking that no personnel are exposed, then verify the isolation of the equipment by operating the push button or other normal operating control(s) or by testing to make certain the equipment will not operate.

 **CAUTION!** Return operating control(s) to neutral or "off" position after verifying the isolation of the equipment.

8. The machine or equipment is now locked out.

RESTORING EQUIPMENT TO SERVICE

When the servicing or maintenance is completed and the machine or equipment is ready to return to normal operating condition, the following steps shall be taken.

1. Check the machine or equipment and the immediate area around the machine to ensure that nonessential items have been removed and that the machine or equipment components are operationally intact.
2. Check the work area to ensure that all personnel have been safely positioned or removed from the area.
3. Verify that the controls are in neutral.
4. Remove the lockout devices and re-energize the machine or equipment.

NOTE: The removal of some forms of blocking may require re-energization of the machine before safe removal.



5. Notify affected personnel that the servicing or maintenance is completed and the machine or equipment is ready for use.

PROCEDURE INVOLVING MORE THAN ONE PERSON

In the preceding steps, if more than one individual is required to lock out the equipment, **each shall place his own personal lock on the energy isolating devices.**

2.3 Safety Labels Description

See table below for safety labels description.

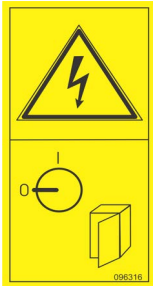
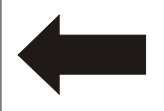
Label View	Description
	096317 CAUTION! Read and understand operator's manual before handling the machine.
	099220 Close guards prior to operating the machine
	096316 Electric box opening is possible with the switch in "0" position only.
	S20097-US Motor rotate direction

SECTION 3 SETUP

3.1 Resaw Setup

Use a forklift or other appropriate equipment to move the resaw.

WARNING! Use extreme care and proper equipment to lift and move the machine. Lift the machine from sides equipped with fork pockets only, never from under the front or rear of the base or upper saw head. Failure to do so may result in personal injury and/or machine damage.

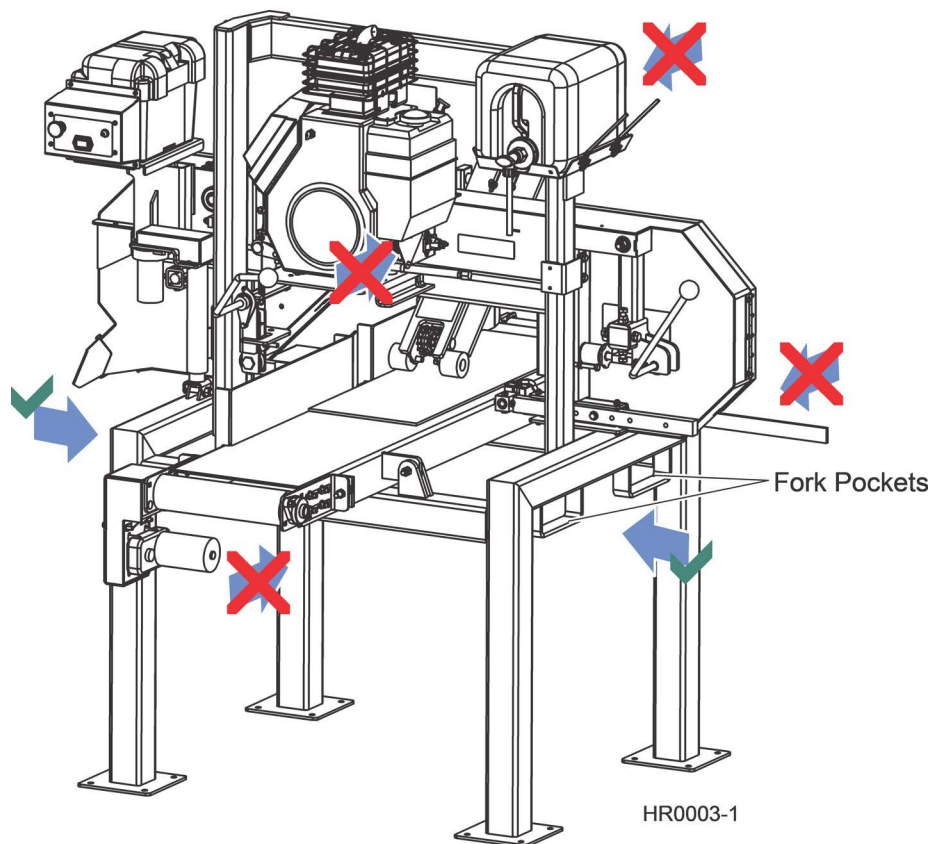



FIG. 3-1

Place the resaw on a concrete foundation strong enough to support the weight of the machine. Allow for room around the resaw to feed and remove material. Secure the resaw to the foundation with anchor bolts.

3.2 Electrical Installation (HR130 E15 Only)

 **DANGER!** Make sure all electrical installation, service and/or maintenance work is performed by a qualified electrician and is in accordance with applicable electrical codes.

 **CAUTION!** Make sure that the machine you have purchased can be powered with the provided power source before making any connections. Do not connect the machine to the improper power source. Serious injury, death or damage to the equipment will result.

NOTICE: Have a qualified electrician install the power supply before receipt of your resaw. The power supply must meet the enclosed specifications concerning wire size, fused disconnect, and voltage. The electrical installation must also meet local codes.

Have a qualified electrician present when the resaw is to be installed. All relevant motor specifications and wiring information are provided. When scheduling an electrician for the day of installation, please confirm that they have enough of the proper size cable (wiring). Many electricians may not stock this cable, which could seriously delay installation and training.

All electrical installation must meet local electrical codes. Install a fused disconnect switch within sight of the machine. The disconnect must be equipped with Class J fuses. Fuse size will be determined by the conductor wire size, but must be at least as large as the full-load amperage (FLA) of the machine (see electrical information below). Fuses supplied in the resaw electrical control are sized for short-circuit protection only. The motor is configured with internal thermostats overload protection. If an overload condition does occur, the thermostats shut the motor down and the motor cannot be restarted until it cools to a safe operating temperature.

Model	FLA of Largest Load	FLA	IR (AIC)	SCCR	Volts	Hz	PH	Transformers required to convert resaw to			
								240V	400V	480V	600V
HR130EB15	35	40.4A	200kA	1kA	240V	60	3	X	078212	X	078213
HR130EC15	17.5	22A	200kA	1kA	480V	60	3	X	069616	X	068047

TABLE 3-1

Route the incoming power supply to the main electrical control cabinet. Punch a knockout in the box and route the cable through the box and secure the cable properly. Connect to cable wires to the power disconnect in the upper-right corner of the cabinet. Connect the ground wire to a panel mount stud.

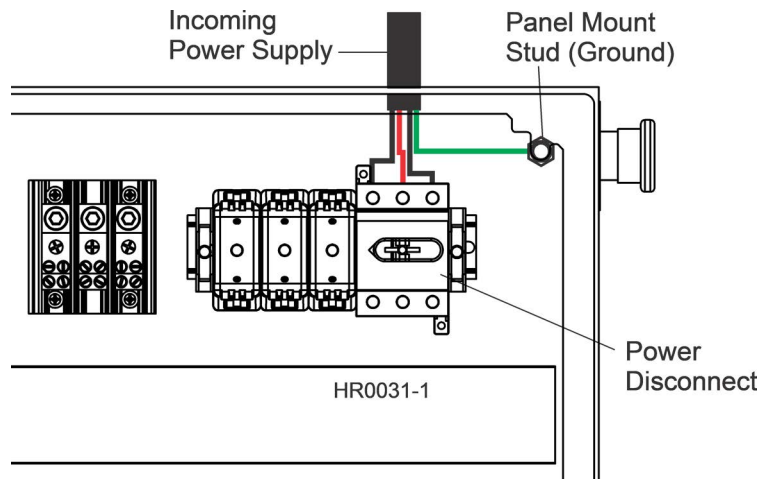

FIG. 3-2

This table lists the specifications for the resaw blade motor.

Electric Blade Motor Specifications	HR130EB15	HR130EC15
Horsepower	15	15
RPM	3500	3500
Volts	230	460
Full-Load Amps	35	17.5
SF	1.0	1.0
NOM EFF	85.5	85.5
Frame	215T	215T
Design	L	L
AMB	40° C	40° C
INS	F3	F3
PH	3	3
ENCL	TEFC	TEFC
Code	G	G
Duty	Saw	Saw

TABLE 3-2

3.3 Upper Hold-Down Adjustment



CAUTION! Be sure the hold-down roller assembly is adjusted to avoid contact with the blade before operating the machine. Failure to do so may result in damage to the machine.

Loosen the four hold-down adjustment bolts and move the hold-down roller in or out as desired. Adjust the hold-down roller to secure material as close to the blade as possible without interfering with the blade. This adjustment will vary depending on the height of the blade and the material being processed.

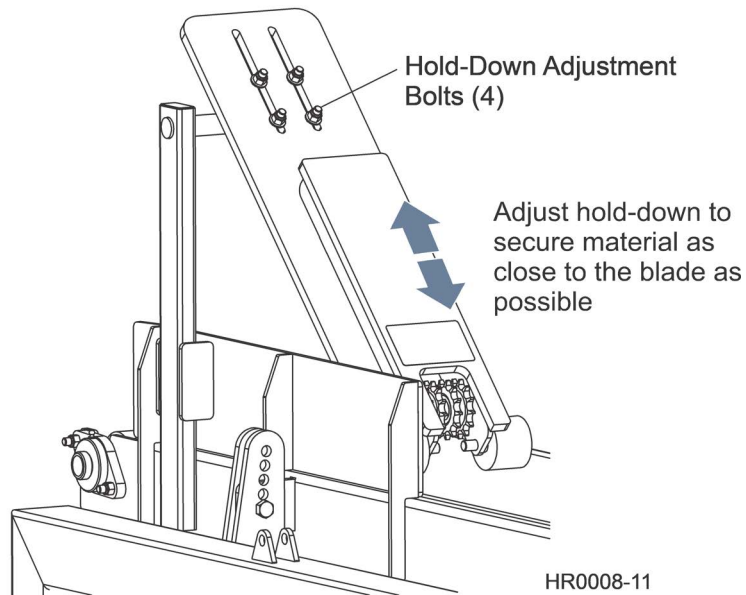

FIG. 3-3

3.4 Blade Guide Arm Adjustment

The outside blade guide arm can be relocated to position the outer blade guide relative to the material to be sawn. In general, the outer guide should be positioned as close to the material as possible.

To relocate the outer blade guide arm, remove the two arm mounting bolts and hardware. Loosen the two top arm locking set screws and move the arm in or out to align the mounting holes. Retighten the top locking set screws and replace the mounting bolts and hardware.

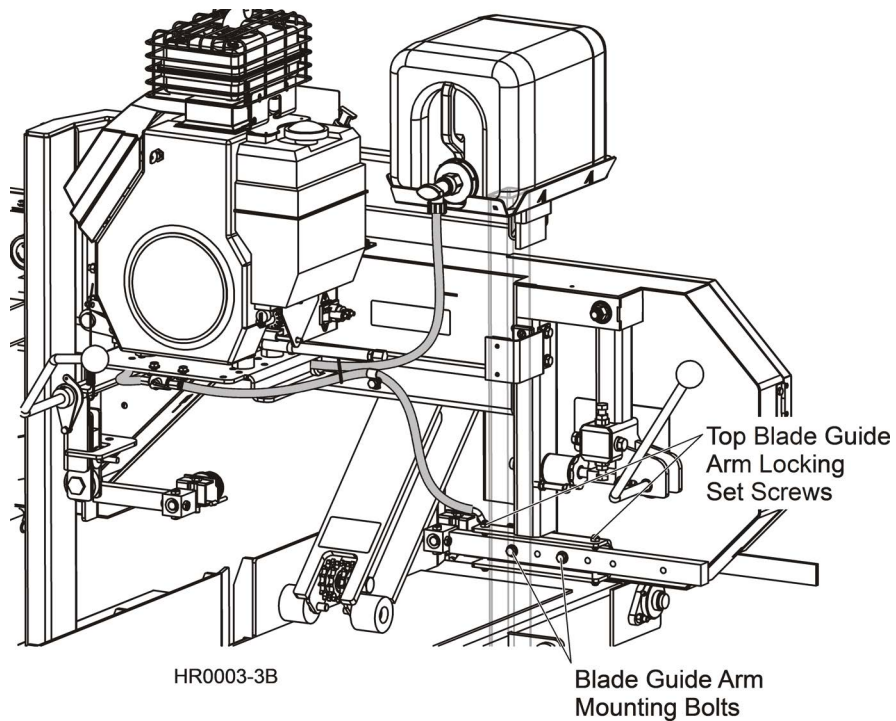

FIG. 3-4

3.5 Conveyor Tilt Adjustment

The conveyor table can be tilted to allow cutting of tapered lap siding. To tilt the conveyor, remove the tilt adjustment bolts. Lift the conveyor table to align the desired bracket holes. Each hole increases the tilt 2 degrees. Replace the tilt adjustment bolts and tighten the nuts to secure the conveyor table at the desired tilt setting.

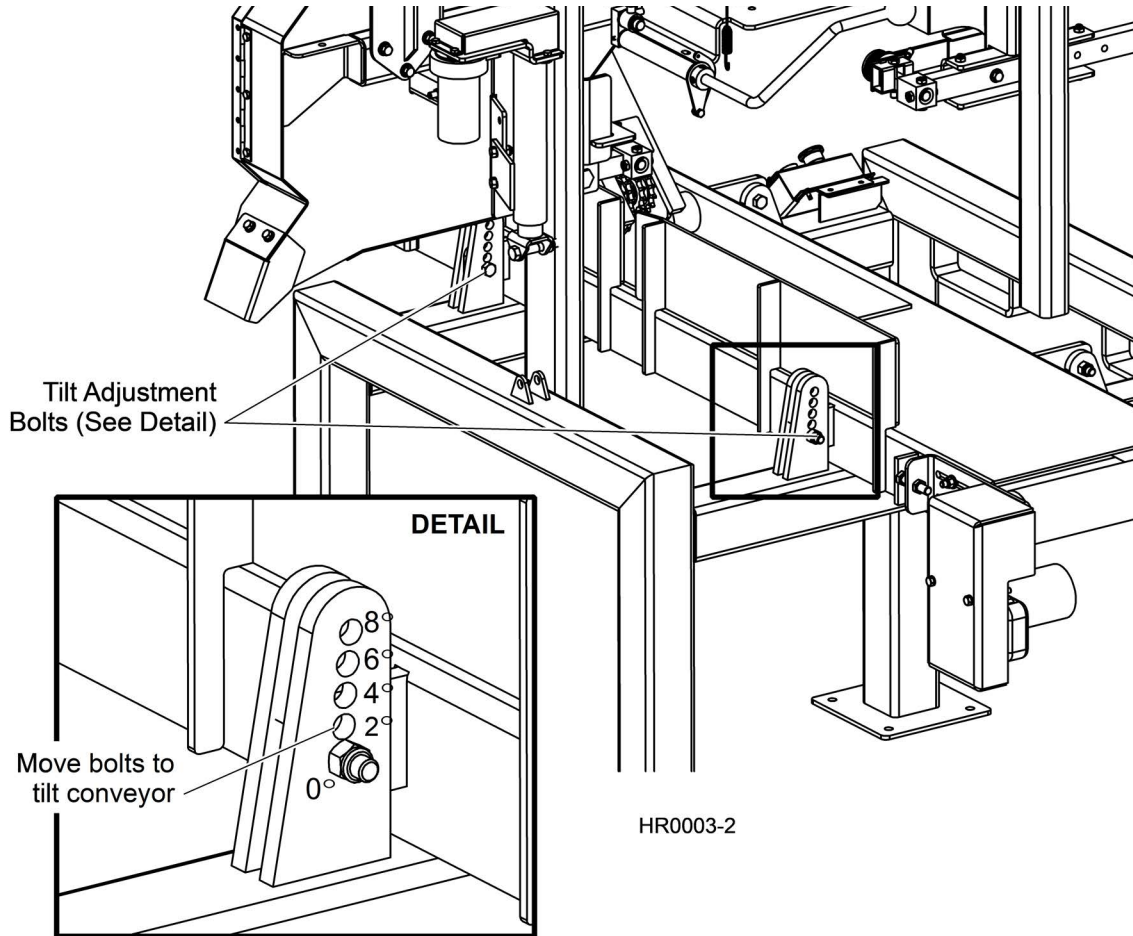

FIG. 3-5

NOTE: If equipped with the optional conveyor tables, loosen the end table mount bolts and tilt the tables to align with the conveyor ([See Section 1.10](#)). Retighten the mount bolts.

3.6 Shingle Belt Installation (Optional)

1. Turn the resaw power on and use the feed rate switch to start the resaw conveyor belt. Stop the belt when the belt seam is on top and easily accessible. Push the emergency stop to turn resaw power off.
2. Loosen the belt tensioners on each side of the resaw frame and push the belt roller in to provide slack in the conveyor belt.
3. Remove the seam wire to separate the belt at the seam and remove the conveyor belt from the resaw.
4. Place the shingle belt on the resaw frame and secure the seam with the seam wire. Adjust the belt tensioners on each side of the resaw frame to tension the shingle belt.
5. Lift the hold-down roller arm and install the shingle stop assembly to the resaw frame side plate just in front of the blade. Tighten the clamping bolts to secure the stop assembly to the resaw.

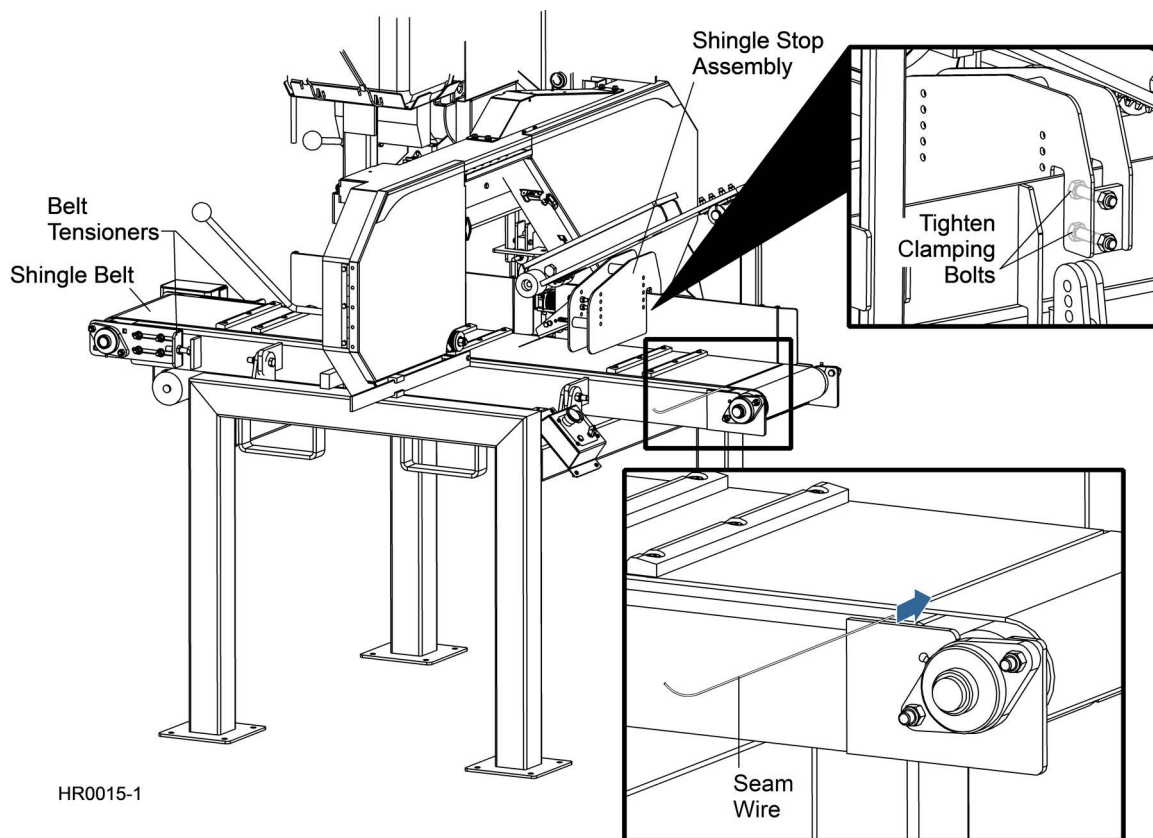

FIG. 3-5

3.7 Tensioning The Blade

The blade tensioner is factory-set so proper blade tension is achieved when the rubber spring is compressed 3/16" (4.8 mm). An indicator bolt is provided to indicate when the rubber spring has been compressed properly. To tension the blade, turn the blade tension handle up until it locks in place.



WARNING! Use both hands to operate the blade tensioner handle. Failure to do so may result in injury.

Check the back side of the rubber spring washer is aligned with the indicator bolt head. If not, release the blade tension and turn the tensioner shaft counterclockwise to compress the rubber spring more; clockwise to compress the rubber spring less.

Use the scalloped disk to turn the tensioner shaft.

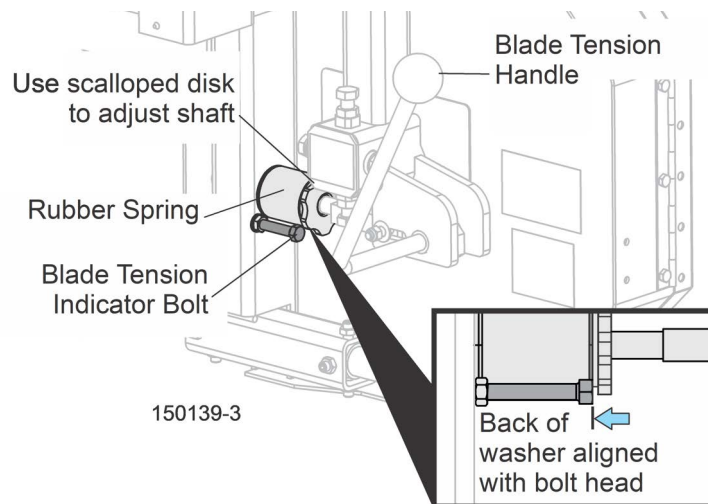

FIG. 3-5

Tension the blade and recheck the alignment of the rubber spring washer with the indicator bolt head.

Check the blade tension occasionally when adjusting the cant control or while cutting. As the blade and belts heat up and stretch, the blade tension will change. Adjust the tensioner shaft as necessary to maintain proper blade tension.

3.8 Replacing The Blade



DANGER! Always disengage the blade and shut off the resaw motor before changing the blade. Failure to do so will result in serious injury.



WARNING! Always wear gloves and eye protection when handling bandsaw blades. Changing blades is safest when done by one person! Keep all other persons away from area when coiling, carrying or changing a blade. Failure to do so may result in serious injury.

Open the two blade housing covers that cover the blade wheels. Turn the blade tension handle to release the blade tension until the wheel is pulled in and the blade is lying loose in the blade housing. Lift the blade out of the blade housing.

When installing a blade, make sure the teeth are pointing the correct direction. The teeth should be pointing toward the infeed and sawdust chute sides of the resaw. Install the blade so it is lying around the wheels.

Position 1 1/4" wide blades on the wheels so the gullet is 1/8" (3.0 mm) out from the edge of the wheel. Position 1 1/2" wide blades on the wheels so the gullet is 3/16" (4.5 mm) out from the edge of the wheel.

Close the blade housing cover.

Next, turn the tension handle until the blade is tensioned correctly.

3.9 Tracking The Blade

1. Make sure the blade housing covers are closed and all persons are clear of the open side of the saw head.
2. Start the motor, rotating the blade until the blade positions itself on the wheels.



WARNING! Do not spin the blade wheels by hand. Spinning the blade wheels by hand may result in serious injury.

3. Turn off the motor, open the blade housing covers and check the position of the blade on the blade wheels.

Position 1 1/4" wide blades so the gullet is 1/8" (3.0 mm) out from the edge of the blade wheel ($\pm 1/16$ [1.5 mm])($\pm 1/32$ [.75 mm]).

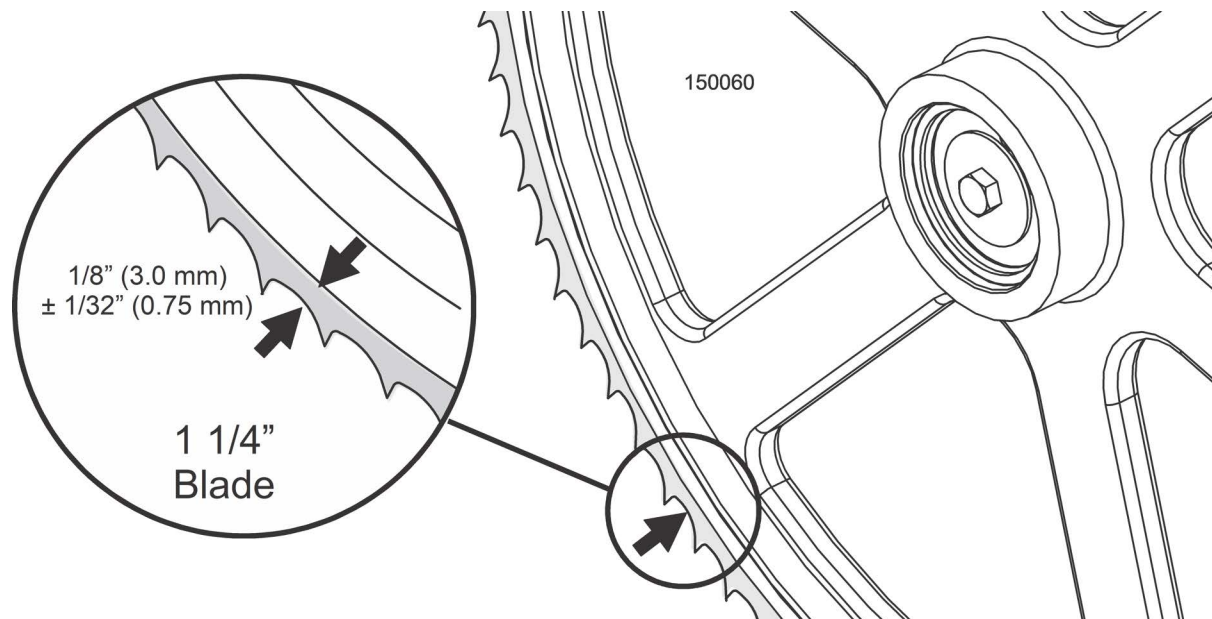
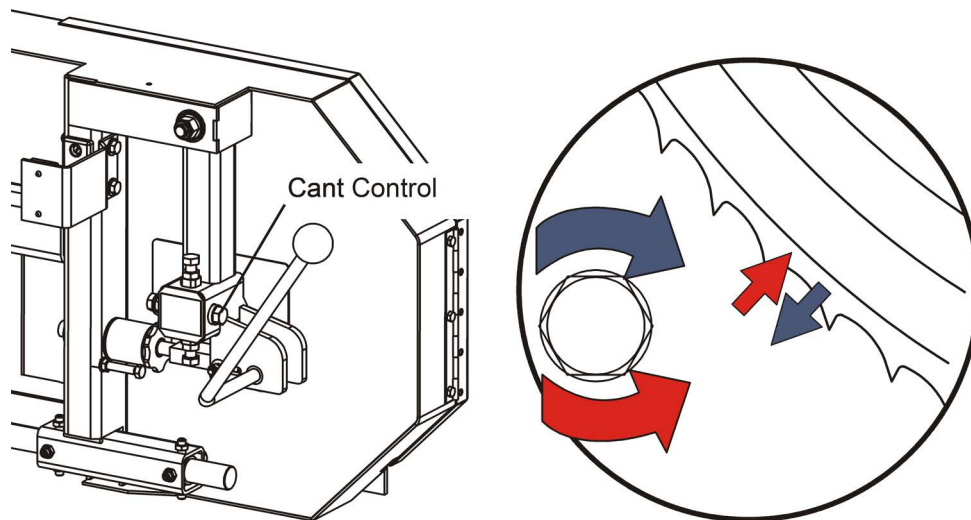

FIG. 3-5

To adjust where the blade travels on the blade wheels, use the cant control.



150171-1

FIG. 3-6

If the blade is too far out, back the blade onto the wheel by turning the cant control counterclockwise. If the blade is too far in, turn the cant control clockwise until the gullet of the blade is the correct distance from the front edge of the wheel.

4. Adjust the blade tension if necessary to compensate for any changes that may have occurred while adjusting the cant control.
5. Close the blade housing covers.



DANGER! Make sure all guards and covers are in place and secured before operating the resaw. Failure to do so may result in serious injury. Be sure the blade housing and pulley covers are in place and secure.

NOTICE! After aligning the blade on the wheels, always double-check the blade guide spacing and location. ([See page 1-17](#) for more information.)

3.10 Table Setup (Optional)

Optional conveyor tables are available to handle material to improve productivity. The tables allow operators to stage material on the infeed and outfeed ends of the resaw. A table mounted to the side of the resaw allows the return of material to be refeed into the resaw.

The table components are available in modules so the customer can configure the setup most ideal for their operation:

Part No.	Description	Comments
HRTBL-KIT	Table Kit, Complete HR	Includes two end tables, mounting brackets and a side table
HRTBL-END1	Table Assembly, HR End	4' infeed/outfeed table. Multiple tables can be connected end-to-end for longer configurations
HRTBL-MOUNT	Mount Assembly, HR Table	Includes brackets to mount tables to the HR100 Series Resaw
HRTBL-SIDE	Table Assembly, HR Side	Return table mounts to side of HR100 Series Resaw
HRTBL-END2	Table Assembly, HR Stand-Alone	Free-standing 4' conveyor table

TABLE 3-3

An overview of the table configuration is provided below.

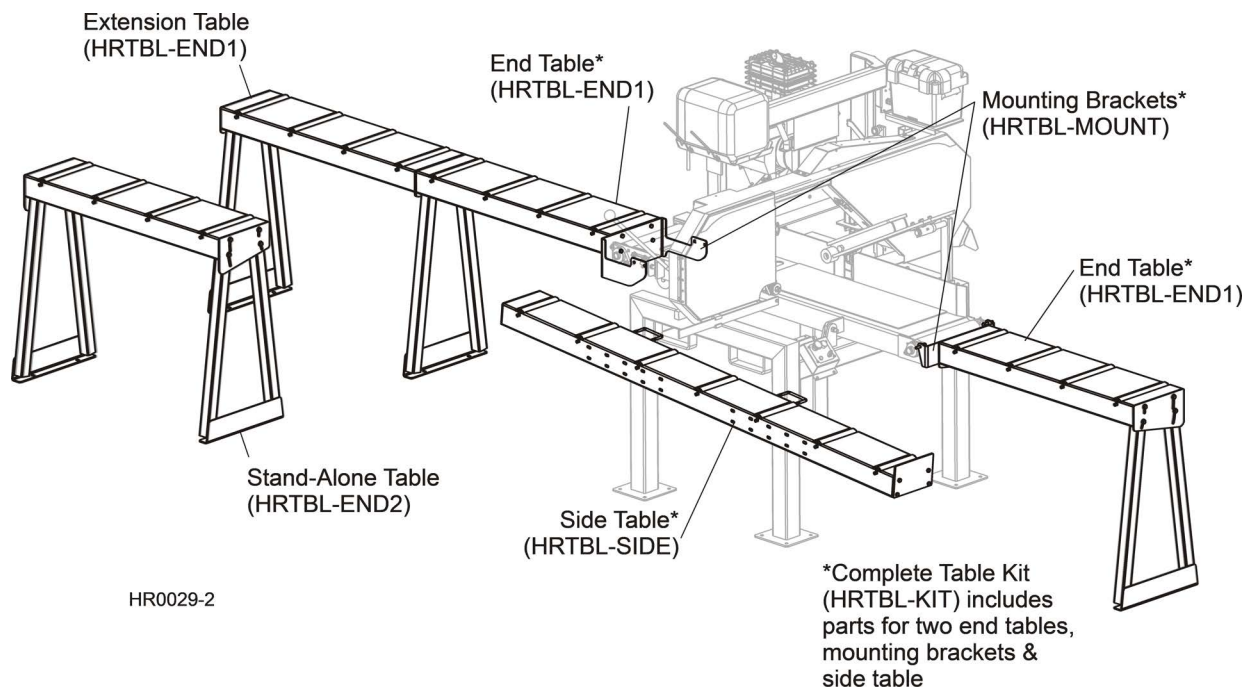

FIG. 3-7

3 Setup

Table Setup (Optional)

At the resaw conveyor, remove the two top conveyor belt bearing mount bolts and lock nuts. Install the front mount plate to the resaw conveyor and secure the mount plate with the provided 3/9-16 x 2" hex head bolts and the original lock nuts.

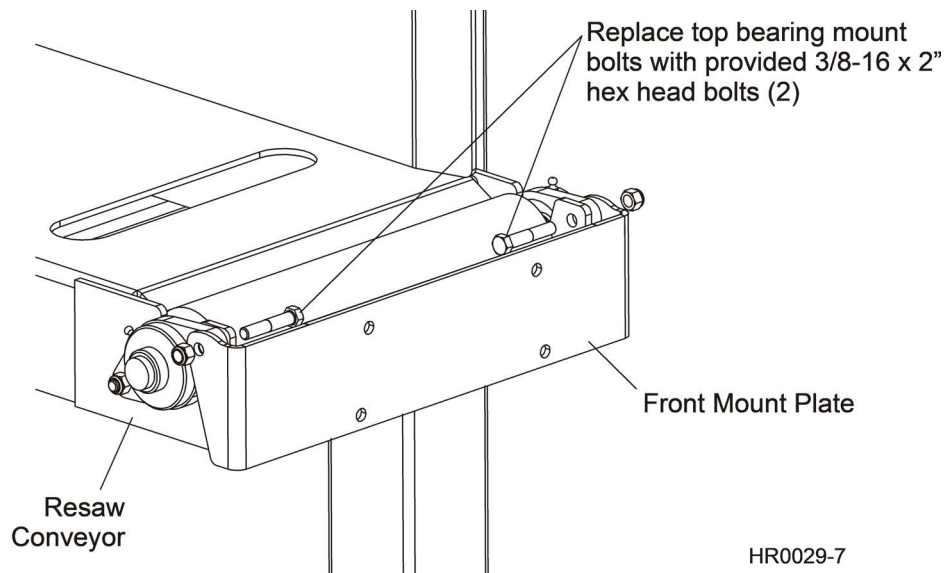

FIG. 3-8

Place the end table assembly in position to align the end table holes with the mounting plate holes. Use the provided 3/8-16 x 1" bolts, flat washers and lock nuts to secure the end table to the mount plate.

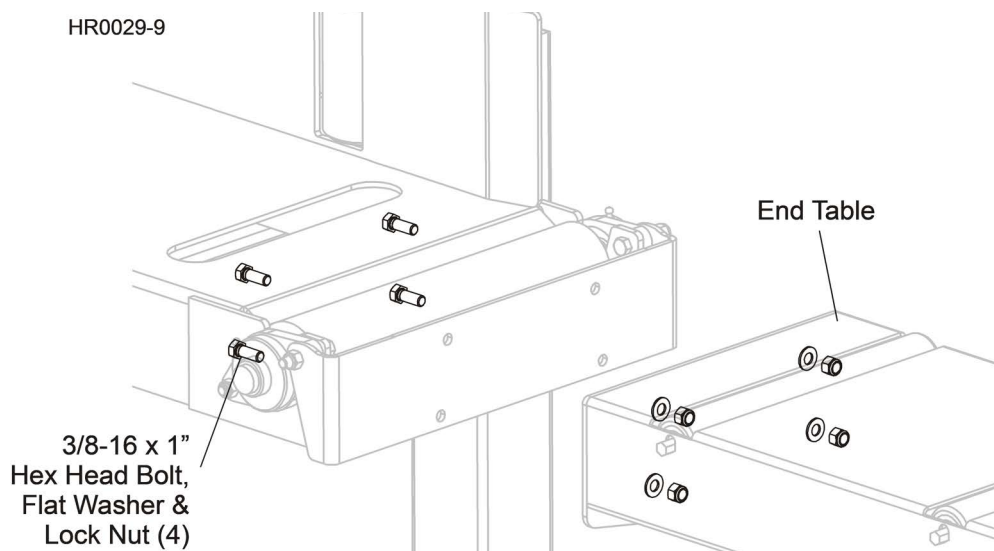

FIG. 3-9

At the other end of the resaw conveyor, remove the four bottom belt tensioner mount bolts, flat washers and lock nuts. Install the provided rear mount plate to the resaw conveyor and replace the original hex head bolts, flat washers and lock nuts.

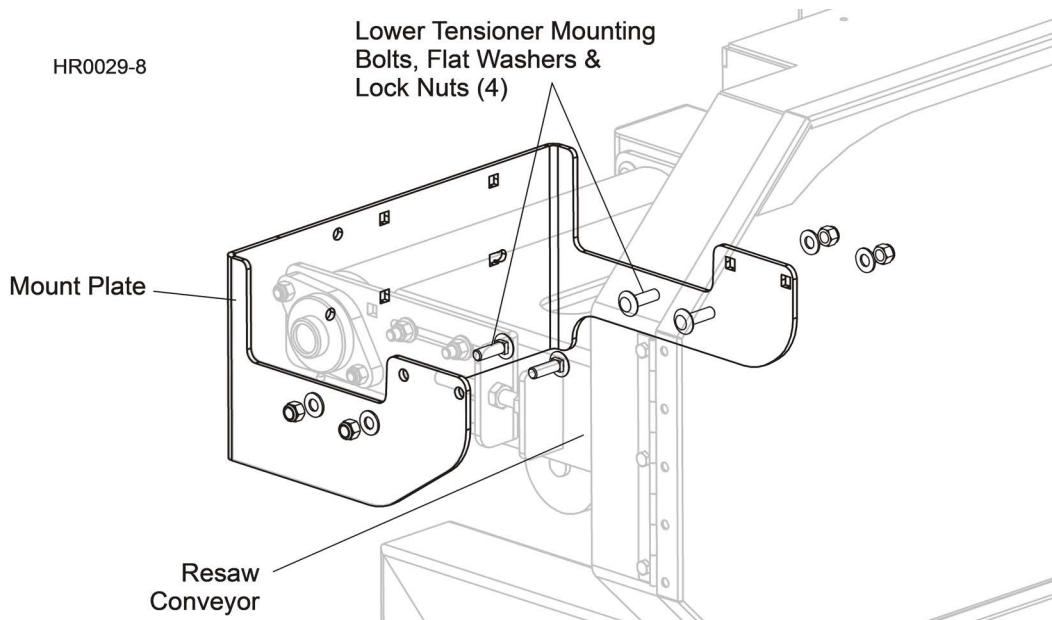

FIG. 3-10

Place the end table assembly in position to align the end table holes with the mounting plate holes. Use the provided 3/8-16 x 1" bolts, flat washers and lock nuts to secure the end table to the mount plate.

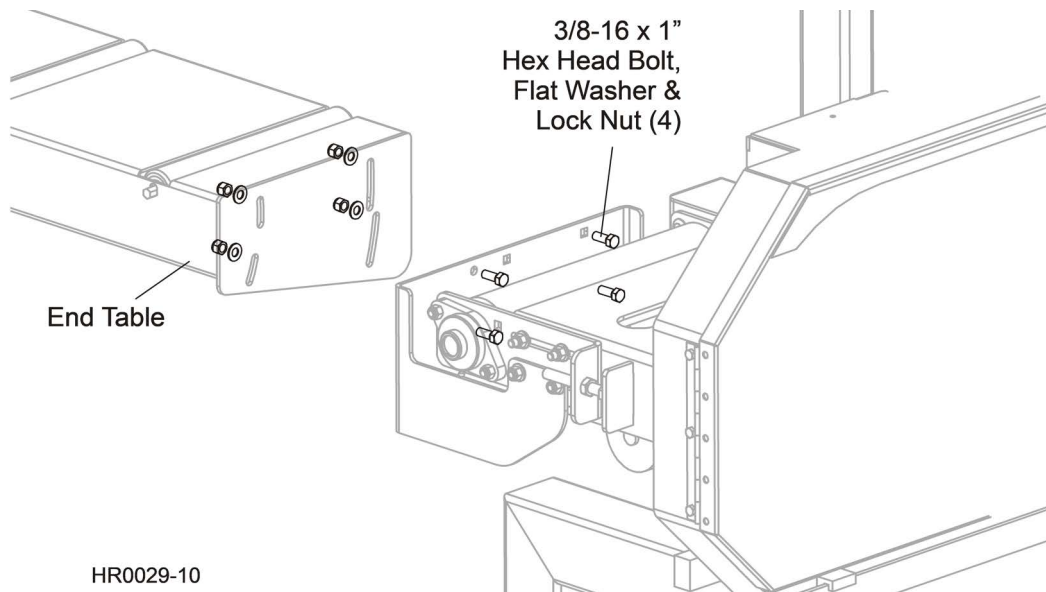

FIG. 3-11

Install the stop end plate to the side table with four 3/8-16 x 1" hex head bolts, flat washers and lock nuts. Assemble the side table to the resaw legs with the four provided U-bolts, flat washers and lock nuts. Mount the side table so it tilts down from front to back, so material will roll toward the infeed end of the resaw.

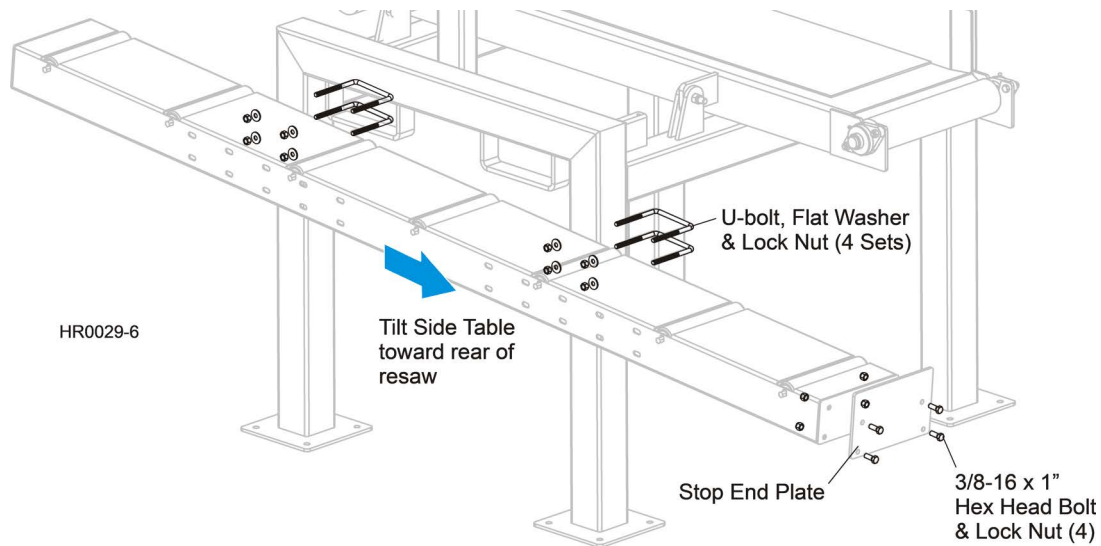

FIG. 3-12

If operating the resaw with the conveyor tilted for siding, loosen the end table mount bracket bolts and tilt the tables to align with the conveyor. Retighten the mount bolts.

SECTION 4 OPERATION

4.1 Up/Down Operation

1. If necessary, release the emergency stop buttons (⊙) on all controls. Release the stop by turning it clockwise until it pops out.
2. Turn the feed rate switch (◀) counterclockwise to its lowest setting.
3. To turn the resaw power on, push the green (■) button on the operator control box. The green power light (■) will illuminate when the power is on.



HR130 Electric

FIG. 4-1

4. Rotate the selector switch to the right to raise the saw head. Rotate the selector switch to the left to lower the saw head. Raise or lower the saw head until the blade is positioned the desired distance above the conveyor belt.



HR130 Electric

FIG. 4-2

5. Use the blade height indicator and scale to determine the height of the blade above the feed conveyor.

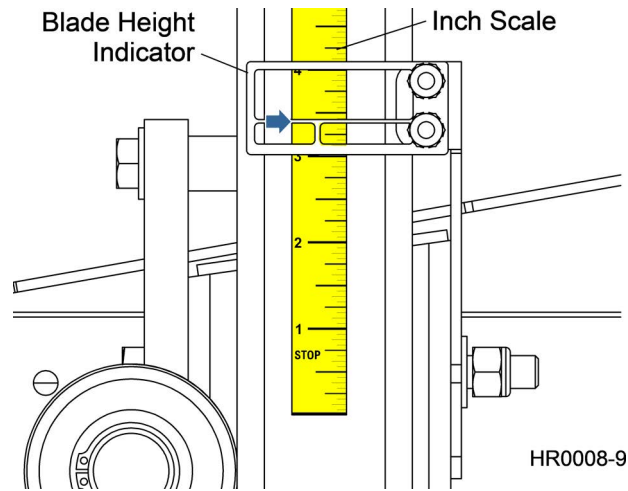

FIG. 4-3

4.2 Machine Start



DANGER! Always be sure the blade is disengaged and all persons are out of the path of the blade before starting the engine/motor. Failure to do so will result in serious injury.

1. Clear any loose objects from the area of the blade, engine/motor, and drive belt.
2. Be sure the blade housing and pulley covers are in place and secure before starting the engine. Use the rubber latches to fasten the blade housing covers shut.

Electric Models (HR130)

3. Turn the main disconnect switch to the ON position.
4. If necessary, release the emergency stop buttons (Ⓢ) on the operator and electrical cabinet controls. Release the stop by turning it clockwise until it pops out.
5. To turn the machine power on, push the green power button (■) on the operator control box. The button power light will illuminate when the power is on.
6. Press the green blade motor START button (■) located on the operator control to start the blade motor.
7. Press the green feed motor START button (●) located on the operator control to start the blade motor.
8. To turn off a motor, press the red motor STOP button on the operator control. To stop all motors, push either emergency stop button on the operator control or electrical cabinet. Turn the main disconnect switch to the OFF position.

4.3 Clutch Operation

The clutch/brake lever is located next to the engine/motor.

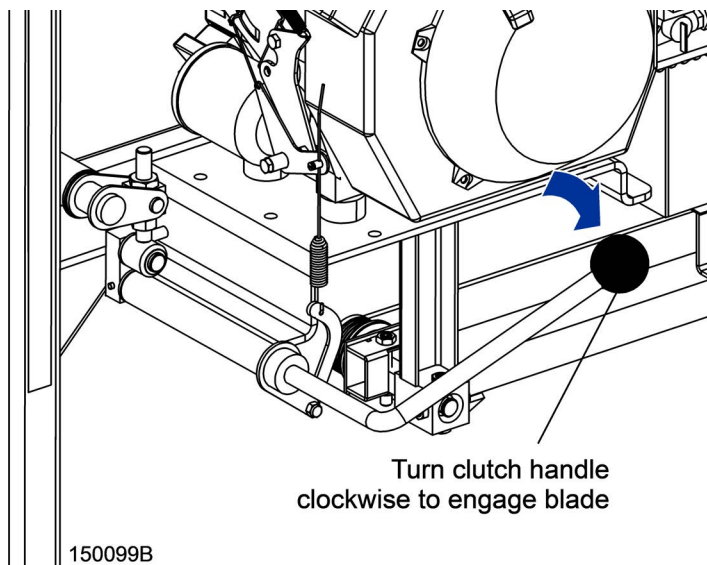

FIG. 4-3

1. To engage the blade, pull the clutch lever clockwise until it locks in the down position. This engages the drive mechanism and increases the engine speed to full throttle.
2. To disengage the blade, raise the clutch lever to the up position. This disengages the drive belt and returns the engine to idle (gas/diesel models only).

4.4 Feed Operation

1. Turn the feed rate switch (← ) clockwise to the desired feed rate.



HR130 Electric

FIG. 4-4

2. Feed the first board into the resaw. Place the material on the feed belt, against the fence. When the blade starts to cut the board, turn the feed rate switch all the way down to stop the feed. Disengage the blade and pull the board out. Check the thickness of the cut and make any needed adjustments.

NOTE: Feed rate is affected by the species and the width of the board being cut. The sharpness, set of the blade, and the available horsepower of your engine also will affect the feed rate. If the engine continually "bogs" down, or if the quality of the cuts you are making gets continually worse, adjust the feed rate or change the blade.

3. Turn the feed rate switch clockwise to the desired feed rate. Feed material continuously through the resaw. When material reaches the outfeed end of the belt, remove it and return it to the feed end if more cuts are desired.
4. When sawing is complete, turn the feed rate switch all the way counterclockwise, disengage the blade and stop the engine.

4.5 Water Lube Operation

The Water Lube System keeps the blade clean. Water flows from a 5-gallon (18.9 liter) bottle through a hose to the blade guide where the blade enters the log. A valve in the bottle cap controls the amount of water flow.

Install the water bottle bracket at the top of the saw head mast.

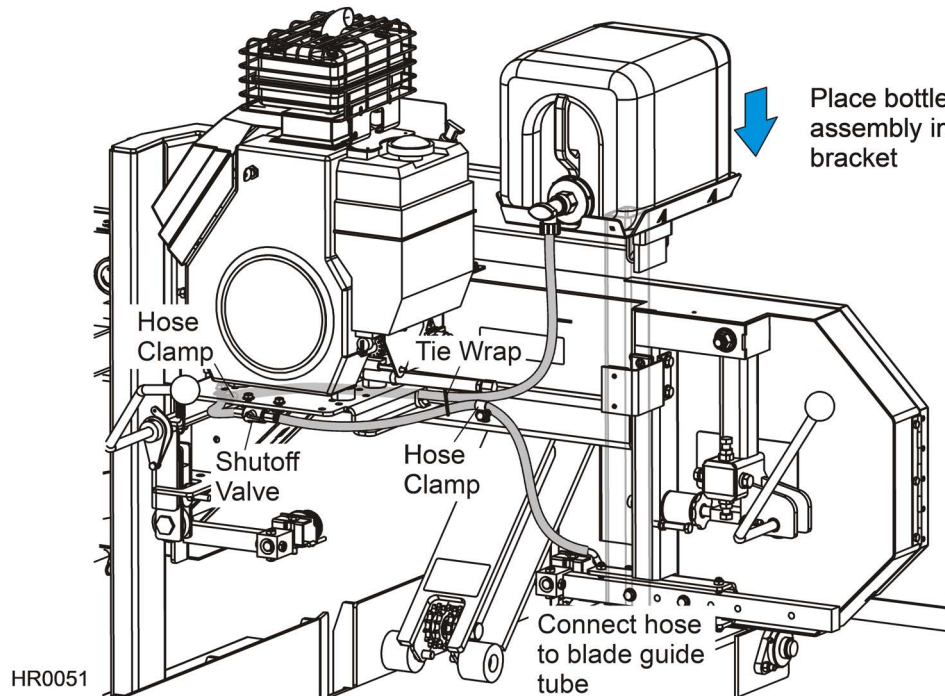

FIG. 4-4

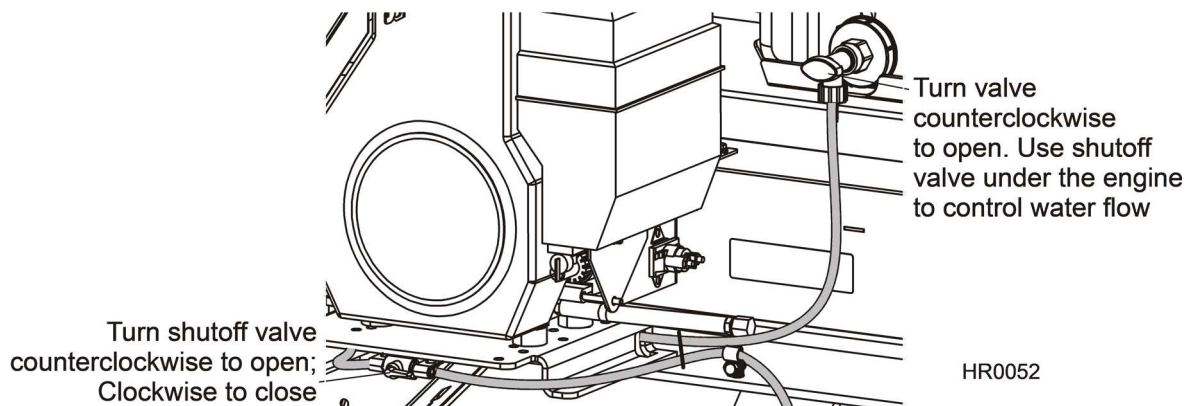

FIG. 4-4

Not all types of wood require the use of the Water Lube System. When it is needed, use just enough water to keep the blade clean. This saves water, and lowers the risk of staining the boards with water. Usual flow will be 1-2 gallons (3.8-7.6 liters) per hour.

Before removing the blade, engage the blade. Let the blade spin with water running on it for about 15 seconds. This will clean the blade of sap buildup. Wipe the blade dry with a rag before storing or sharpening.

For further lubrication benefits, add one 12oz. bottle of Wood-Mizer Lube Additive to 5 gallons of water. Wood-Mizer Lube Additive enables some previously impossible timbers to be cut by significantly reducing resin buildup on the blade. It helps

to reduce heat buildup, wavy cuts, and blade noise. This biodegradable and environmentally friendly pre-mix includes a water softener additive, so it works with hard water.



WARNING! Use ONLY water and Wood-Mizer Lube Additive with the water lube accessory. Never use flammable fuels or liquids such as diesel fuel. If these types of liquids are necessary to clean the blade, remove it and clean with a rag. Failure to do so can damage the equipment and may result in serious injury or death.

If you are sawing in freezing temperatures, remove the water lube bottle from the sawmill when done sawing and store it in a warm place. Blow any remaining water from the water lube hose.

4.6 Shingle Belt Operation (Optional)

1. Install the shingle belt and stop assembly as described in [Section 1.6](#).
2. Turn the resaw power on and use the feed rate switch to start the resaw shingle belt. Stop the belt to position a set of cleats in front of the shingle stop assembly. Push the emergency stop to turn resaw power off.
3. Place a stack of shingle blocks (two shingles thick, at least 18" and no more than 20" long) on the belt with the front of the blocks sitting on the tapered cleat. The rear end of the blocks should sit flat on the belt.
4. Loosen the stop assembly clamping bolts and adjust the assembly to approximately 1/4" above the bottom shingle block. Tighten the clamping bolts.

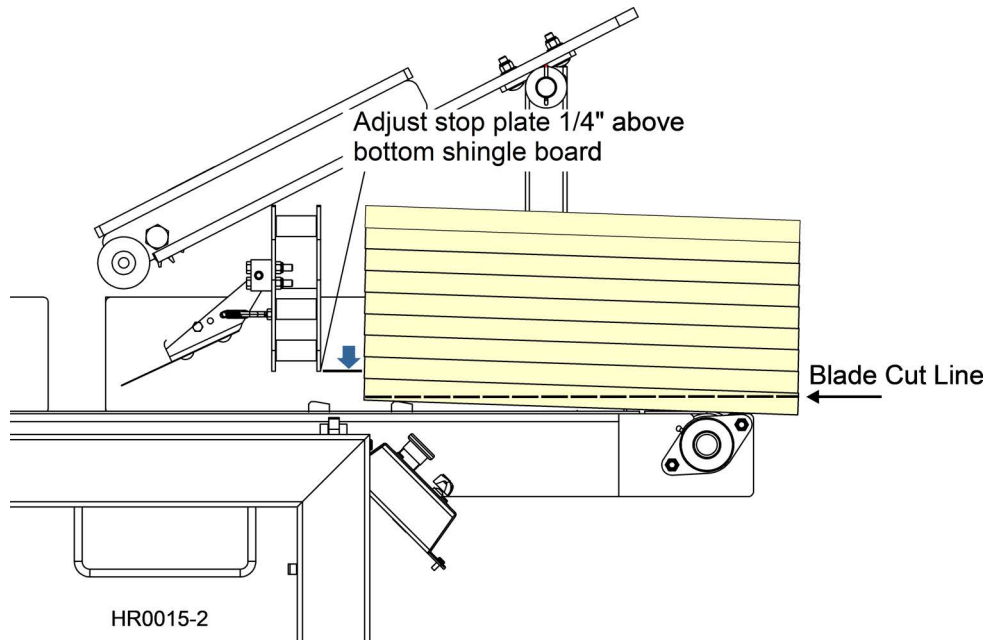



FIG. 4-4

5. Turn the resaw power on and use the up/down toggle switch () to position the blade to cut the shingle blocks in half.



DANGER! Always be sure the blade is disengaged and all persons are out of the path of the blade before starting the motor. Failure to do so will result in serious injury.

DANGER! Always keep hands away from moving bandsaw blade. Failure to do so will result in serious injury.



DANGER! Always be aware of and take proper protective measures against rotating shafts, pulleys, fans, etc. Always stay a safe distance from rotating members and make sure that loose clothing or long hair does not engage rotating members resulting in possible injury.



WARNING! Secure all loose clothing and jewelry before operating this machine. Failure to do so may result in serious injury or death.

WARNING! Always wear eye, ear, respiration, and foot protection when operating or servicing this machine.

6. Turn the feed rate switch () counterclockwise to its lowest setting.

7. Start the engine and engage the blade. Turn the feed rate switch () clockwise to the desired feed rate.
8. Feed the first board into the Resaw. As the belt rotates, the bottom shingle block should pass under the stop plate and into the blade. When the blade starts to cut the board, turn the feed rate switch () all the way down to stop the feed, turn the resaw power off, disengage the blade and pull the board out. Check the thickness of the cut and make any needed adjustments.
9. Place the block on top of the shingle board stack. Engage the blade and start the feed belt. The resaw will feed each shingle block through the blade. Add more shingle blocks to the stack as the stack gets shorter.

SECTION 5 MAINTENANCE

5.1 Blade Guides



WARNING! Before performing service near moving parts such as blades, pulleys, motors, belts and chains, first turn the key switch to the OFF (#0) position and remove the key. If the key is turned on and moving parts activated, serious injury may result.

Check the rollers for performance and wear every blade change. Make sure the rollers are clean and spinning freely. If not, replace them. Replace any rollers which have worn smooth or have become cone shaped.

5.2 Sawdust Removal



WARNING! Before performing service near moving parts such as blades, pulleys, motors, belts and chains, first turn the key switch to the OFF (#0) position and remove the key. If the key is turned on and moving parts activated, serious injury may result.



Remove the excess sawdust from the blade wheel housings and sawdust chute every blade change.



WARNING! Always keep clear of exiting sawdust. Keep hands, feet and any other objects away from the sawdust chute when operating this machine. Failure to do so may result in serious injury.

WARNING! Always check to ensure the steel fingers inside the sawdust chute are in place before operating this machine. The steel fingers have been designed to help prevent a broken blade or some other object from becoming a projectile and exiting the sawdust chute. Failure to have these fingers in place may result in serious injury.

5.3 Vertical Mast Rails



WARNING! Before performing service near moving parts such as blades, pulleys, motors, belts and chains, first turn the key switch to the OFF (#0) position and remove the key. If the key is turned on and moving parts activated, serious injury may result.

Clean and lubricate the vertical mast rails every **50 HOURS** of operation. Clean with solvent and remove any rust with a light-grade sand paper or emery cloth. Lubricate the mast with motor oil or automatic transmission fluid (ATF).



CAUTION! Never use grease on the mast rails as it will collect sawdust.

5.4 Blade Wheel Belts



WARNING! Before performing service near moving parts such as blades, pulleys, motors, belts and chains, first turn the key switch to the OFF (#0) position and remove the key. If the key is turned on and moving parts activated, serious injury may result.

Rotate the blade wheel belts and check them for wear. Rotating the belts every **50 HOURS** will provide longer belt life. Replace belts as necessary. Use only B57 belts manufactured by Goodyear or Browning.

5.5 Feed System



WARNING! Before performing service near moving parts such as blades, pulleys, motors, belts and chains, first turn the key switch to the OFF (#0) position and remove the key. If the key is turned on and moving parts activated, serious injury may result.

1. Grease the conveyor belt roller bearings and the hold-down pivot with a NLGI No. 2 grade lithium grease every **1000 HOURS** of operation.
2. **PERIODICALLY** check the conveyor belt for wear. Replace a damaged or worn belt as needed. **ALWAYS** check the conveyor belt alignment after installing a new belt. Align the conveyor belt after replacing as necessary ([See Conveyor Belt Alignment](#) in [See Section 1.1](#)).

5.6 Battery Replacement - M221 PLC

The controller's backup battery maintains the RTC (Real-Time Clock) and preserves non-volatile memory contents, including user-defined variables such as machine settings and configuration parameters.

NOTE: Replacement of the battery will lead to the loss of RTC and data not saved in the non-volatile memory.



WARNING! Turn OFF the power before opening the cabinet. If power is left ON during replacement, wear appropriate electrical safety PPE.

NOTE: Risk of data loss. When the battery is replaced, the PLC memory may be cleared and machine settings can be lost. To minimize downtime and ensure the machine can be returned to its previous operating condition, take photos of all important settings before replacing the PLC battery.

See table 5-1. for battery characteristics.

Characteristics	Description
Use	In the event of a transient power outage, the battery powers the RTC and user data.
Backup life	At least 1 year at 25°C maximum (77°F). At higher temperatures, the time is reduced.
Battery monitoring	Yes
Replaceable	Yes
Controller battery type	Lithium coin, BR2032 or CR2032X.

TABLE 5-1



WARNING! Replacement of the battery in the controllers other than with the type specified in this documentation may present a risk of fire or explosion.

Replace the battery **every 12 months** if any of the following conditions apply:

- The machine is frequently powered off.
- The battery has not been replaced within the last 12 months and the machine will be powered off for more than 10 days.
- The machine is located in a high-temperature environment year-round.

Otherwise, replace the battery **at least every 24 months** (do not exceed 24 months).

NOTE: Replace within 120 s after switching off the power.

See **Figure 5-1**. Use an insulated screwdriver to pull out the battery holder from the M221¹

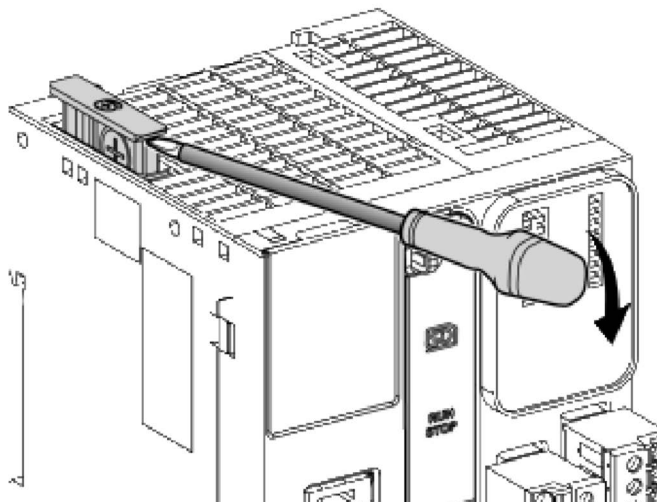

FIG. 5-1

See **Figure 5-2**. Insert the new battery into the battery holder in accordance with the polarity markings on the battery

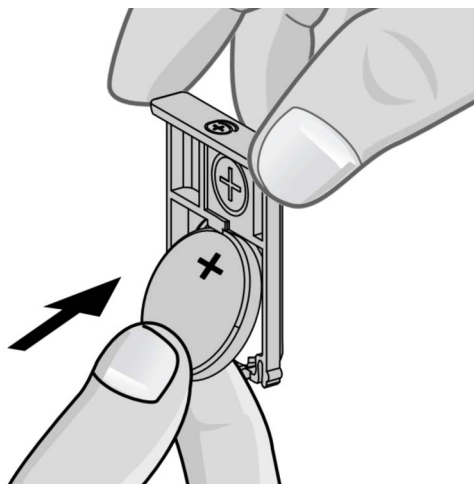

FIG. 5-2

See **Figure 5-3**. Slide in the battery holder of the M221 Logic Controller.

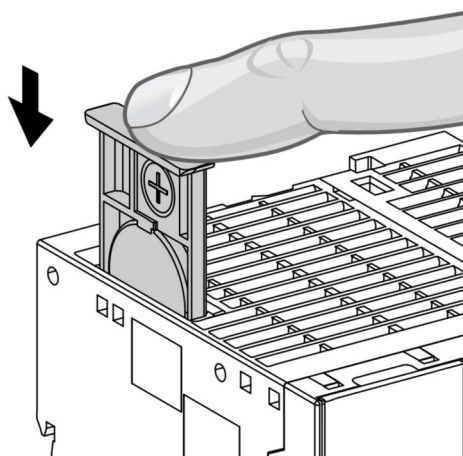

FIG. 5-3

1. Illustration sourced from Schneider Electric.

SECTION 6 ALIGNMENT

6.1 Complete Alignment Procedure

WARNING! Before performing service near moving parts such as blades, pulleys, motors, belts and chains, first turn the key switch to the OFF (#0) position and remove the key. If the key is turned on and moving parts activated, serious injury may result.

1. Install a blade (*See Section 1.8* through Section 1.9 Tracking The Blade).
2. Measure the distance from the conveyor belt to the bottom of the blade near the inside blade guide.
3. Measure the distance from the conveyor belt to the bottom of the blade near the outside blade guide.

When the blade is parallel to the belt, it will measure the same distance from the belt at the inside and outside of the saw head.

Turn the saw head tilt adjustment nut clockwise to raise the outside of the saw head. Turn the nut counterclockwise to lower the outside of the saw head. After the saw head is adjusted parallel to the conveyor belt, check the space between the uppermost mast bearing and mast rail. Adjust as necessary so the space is $1/32'' - 1/16''$.

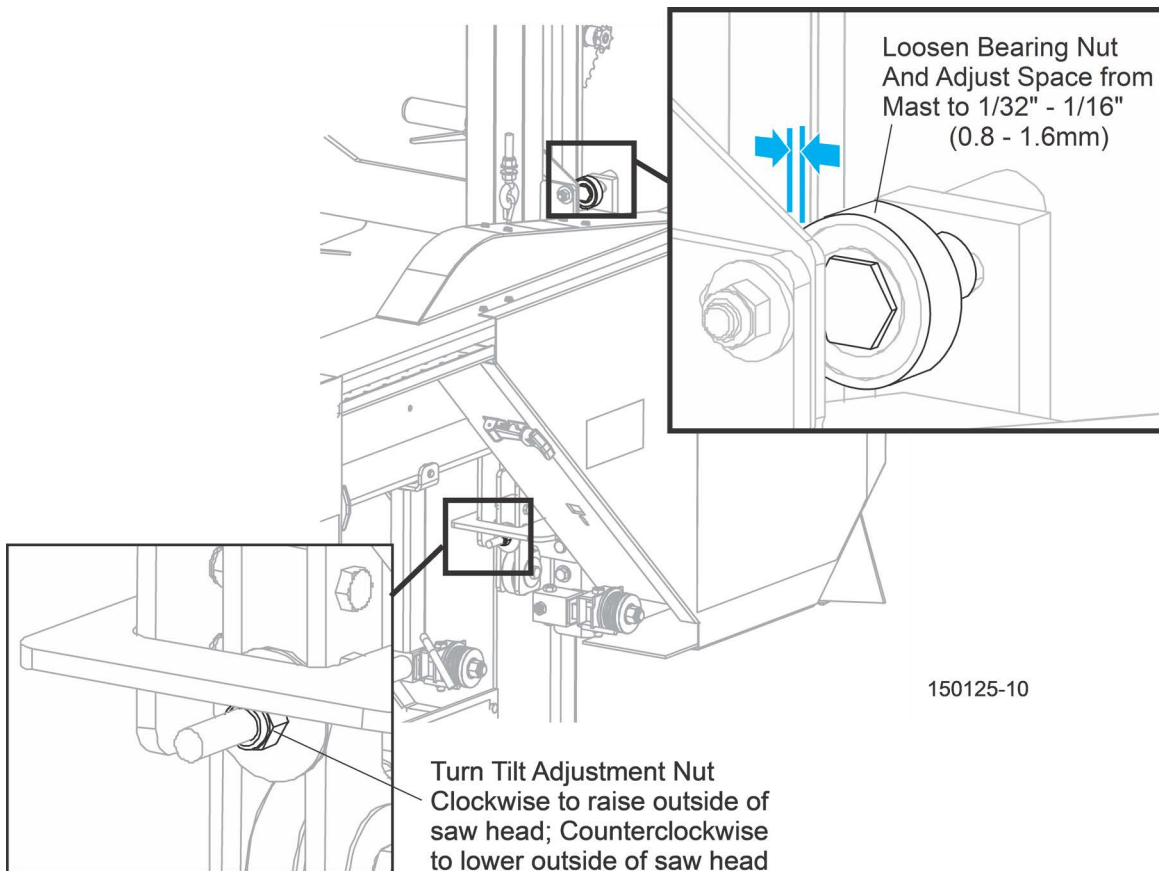

FIG. 6-0

Blade Installation

1. Remove the blade and replace the blade wheel belts. New blade wheel belts are required to perform the complete alignment procedure.
2. Blow sawdust off of the blade guide assemblies. Remove sawdust from the blade housings.
3. Remove the blade guide assemblies.

NOTE: To remove the blade guide assemblies and maintain the tilt adjustments, only loosen one side screw and the top screw. Leaving the other side screw and bottom screw in position will insure you will return the rollers to their original tilt adjustment.

4. Relocate the outer blade guide arm to position the outer blade guide furthest from the inner blade guide ([See Section 1.4](#)).
5. Install a new blade and apply the appropriate tension ([See Section 1.7](#)).
6. Close the blade housing covers and make sure all persons are clear of the saw head.
7. Start the engine.
8. Engage the blade, rotating the blade until the blade positions itself on the wheels.



WARNING! Do not spin the blade wheels by hand. Spinning the blade wheels by hand may result in serious injury.

9. Disengage the blade. Turn the engine off.

Blade Wheel Alignment

The blade wheels should be adjusted so they are level in the vertical and horizontal planes. If the blade wheels are tilted up or down, the blade will want to travel in the tilted direction. If the blade wheels are tilted horizontally, the blade will not track properly on the wheels.

1. Use the blade guide alignment tool to check the vertical alignment of each blade wheel. Attach the tool to the blade near the inner blade guide mount. Be sure the tool does not rest on a tooth or burr, and is lying flat against the bottom of the blade.

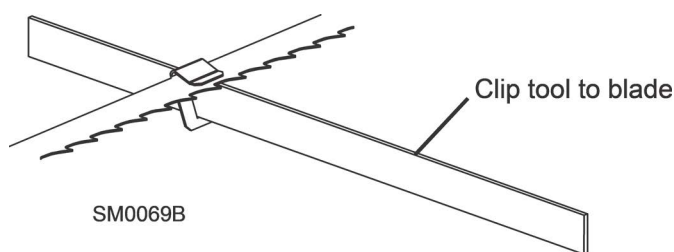

FIG. 6-0

2. Measure from the bottom of the tool to the top surface of the conveyor belt at the front and rear ends of the tool.
3. If the two measurements differ by more than 1/16" (1.5 mm), adjust the vertical tilt of the drive-side blade wheel.

Use the vertical adjustment screws to adjust the drive-side blade wheel. To tilt the wheel down, loosen the top adjustment screw one quarter turn. Loosen the jam nut on the bottom adjustment screw and tighten the screw. Tighten the top and bottom jam nuts.

To tilt the wheel up, loosen the bottom adjustment screw one quarter turn. Loosen the jam nut on the top adjustment screw and tighten the screw. Tighten the top and bottom jam nuts.

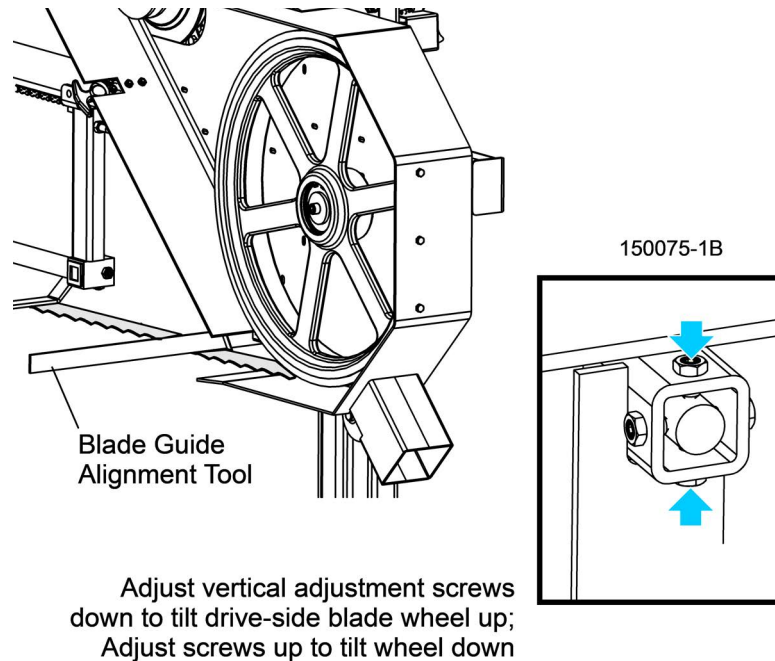
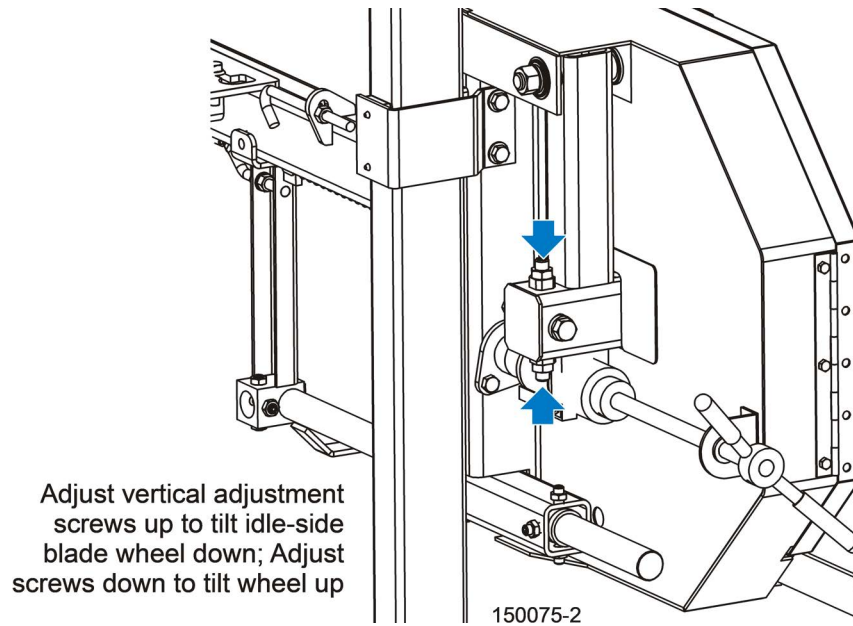

FIG. 6-0

4. Recheck the vertical tilt of the drive-side blade wheel with the blade guide alignment tool. Readjust the blade wheel as necessary until the front and rear of the tool are the same distance from the conveyor belt (within 1/16" [1.5 mm]).
5. Remove the tool from the blade and reattach it near the outer blade guide assembly.
6. Measure from the tool to the conveyor belt at both ends of the tool. If the measurements at the front and rear ends of the tool differ by more than 1/16" (1.5 mm), adjust the vertical tilt of the idle-side blade wheel.

Use the vertical adjustment screws to adjust the idle-side blade wheel. To tilt the wheel up, loosen the bottom adjustment screw one quarter turn. Loosen the jam nut on the top adjustment screw and tighten the screw. Tighten the top and bottom jam nuts.

To tilt the wheel down, loosen the top adjustment screw one quarter turn. Loosen the jam nut on the bottom adjustment screw and tighten the screw. Tighten the top and bottom jam nuts.

FIG. 6-0

7. Recheck the vertical tilt of the idle-side blade wheel with the blade guide alignment tool. Readjust the blade wheel as necessary until the front and rear of the tool are the same distance from the conveyor belt (within 1/16" [1.5 mm]).
8. Check the position of the blade on the idle-side blade wheel.

The horizontal tilt of the blade wheel should be adjusted so that the gullet of an 1-1/4" blade is 1/8" (3 mm) out from the front edge of the wheel ($\pm 1/32$ [0.75 mm]).

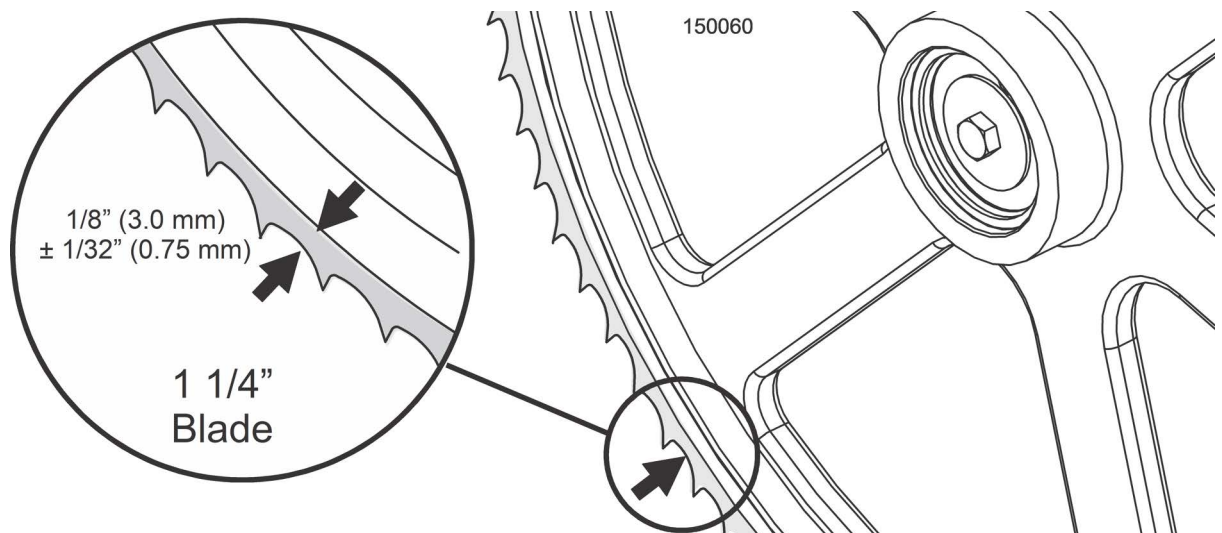
FIG. 6-0

Use the cant control adjustment to adjust the idle-side blade wheel. If the blade is too far forward on the wheel, turn the cant control counterclockwise. If it is too far back on the wheel, turn the cant control clockwise.

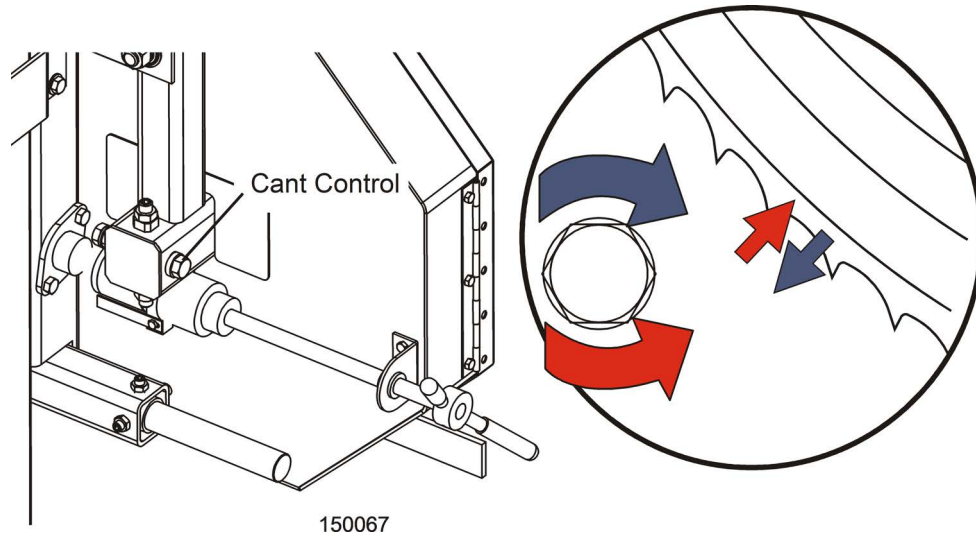
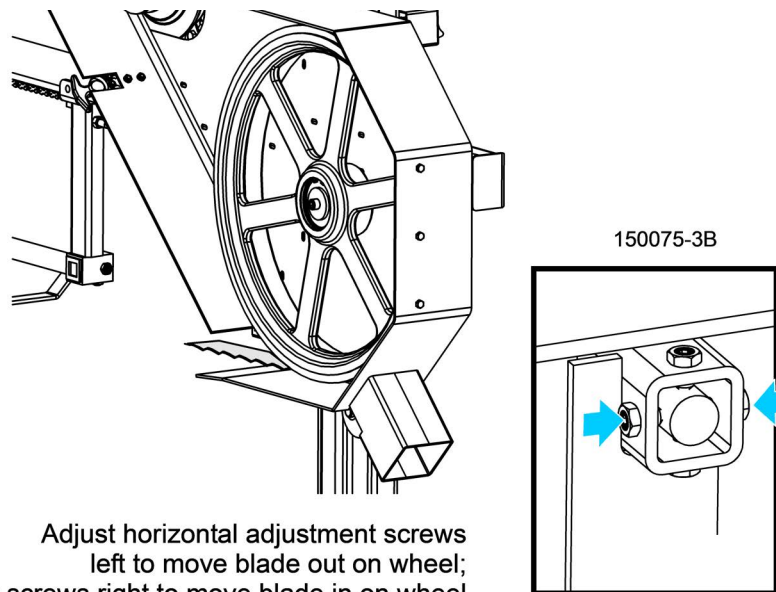

FIG. 6-1

9. Check the position of the blade on the drive-side blade wheel. The blade should be positioned on the wheel as described for the idle-side blade wheel. Adjust the drive-side blade wheel if necessary.

Use the horizontal adjustment screws to adjust the drive-side blade wheel. To move the blade back on the wheel, loosen the right adjustment screw one quarter turn. Loosen the jam nut on the left adjustment screw and tighten the screw. Tighten the left and right jam nuts.

To move the blade out on the wheel, loosen the left adjustment screw one quarter turn. Loosen the jam nut on the right adjustment screw and tighten the screw. Tighten the left and right jam nuts.



Adjust horizontal adjustment screws
left to move blade out on wheel;
Adjust screws right to move blade in on wheel

FIG. 6-1

Blade Guide Installation

Each resaw has two blade guide assemblies that help the blade maintain a straight cut. The two blade guide assemblies are positioned on the saw head to guide the blade on each side of the material being cut.

One blade guide assembly is mounted in a stationary position on the drive side of the saw head. This assembly is referred to as the "inner" blade guide assembly.

The other blade guide assembly is mounted on the idle side of the saw head. It is referred to as the "outer" assembly and is adjustable for various widths of materials to be processed.

NOTE: Before installing the blade guide assemblies, remove the blade guide adjusting screws and apply a lubricating oil such as 10W30 or Dexron III to each screw. This will prevent the screws and threaded holes from corroding and make screw adjustments easier.

1. Install the outer blade guide assembly (with waterlube tube) to the mounting block on the blade guide arm. Position the assembly so the roller flange is 1/8" (3.0 mm) from the blade.
2. Install the inner blade guide assembly to the mounting block on the saw head. Position the assembly so the roller flange is 1/16" (1.5 mm) from the blade.

Tighten the two previously-loosened tilt adjustment screws to secure the blade guide assembly.

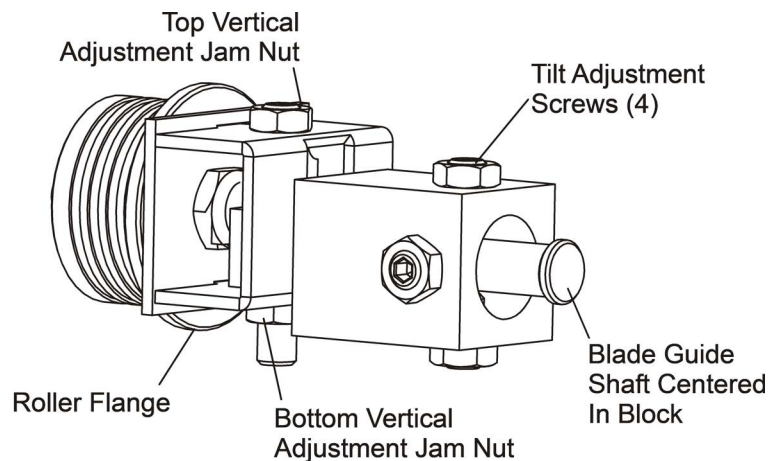

FIG. 6-1

Blade Guide Arm Alignment

The blade guide arm should be parallel to the blade in the vertical and horizontal directions.

1. Relocate the outer blade guide arm to position the outer blade guide closest to the inner blade guide ([See Section 1.4](#)).
2. Place a straight edge on the conveyor belt that will extend the length of the blade guide arm.
3. Measure from the bottom of the blade guide arm to the straight edge at both ends of the arm. The distance to the straight edge should be the same (within 1/32") at each end.

Loosen the mounting bolts and use the vertical adjustment screws to tilt the arm. Loosen the jam nuts and turn the screws as necessary until the arm is parallel to the straight edge. Retighten the jam nuts.

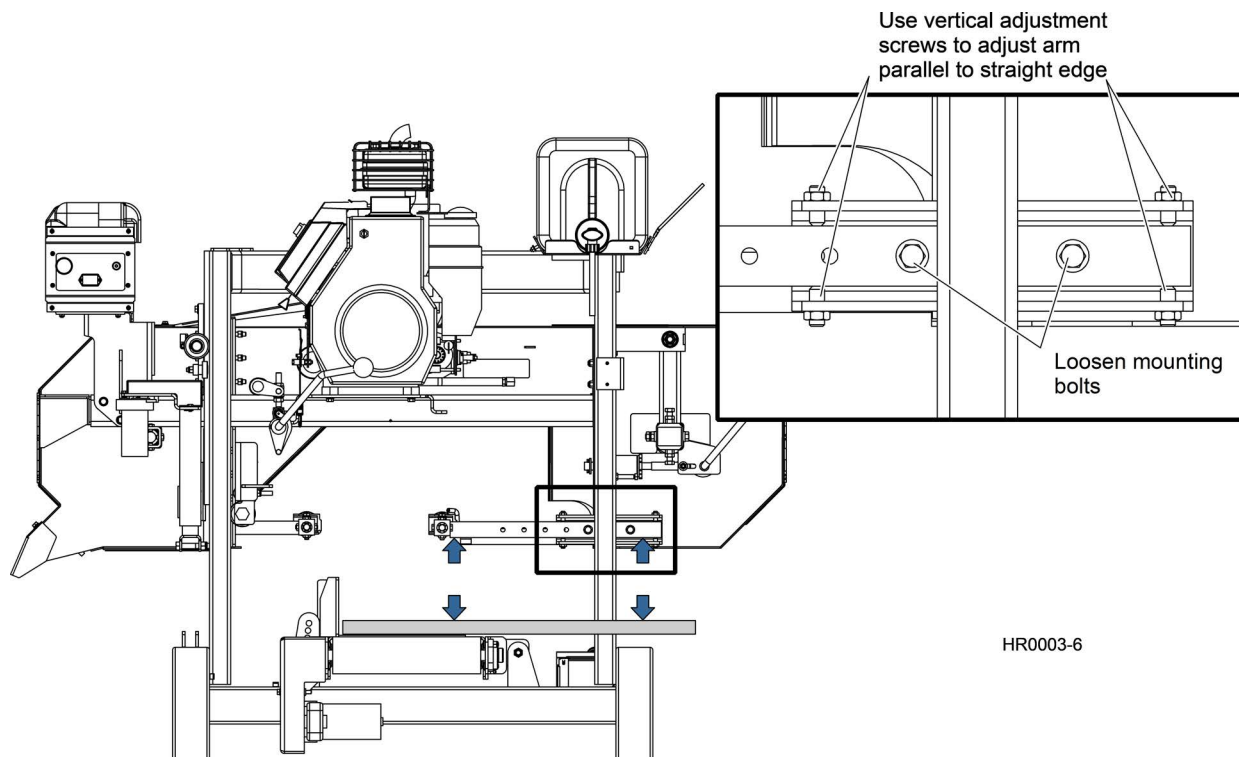

FIG. 6-1

With the blade guide arm still all the way in toward the other blade guide, tighten all the side screws until they touch the arm. Back the screws off 1/4 turn and tighten the jam nuts.

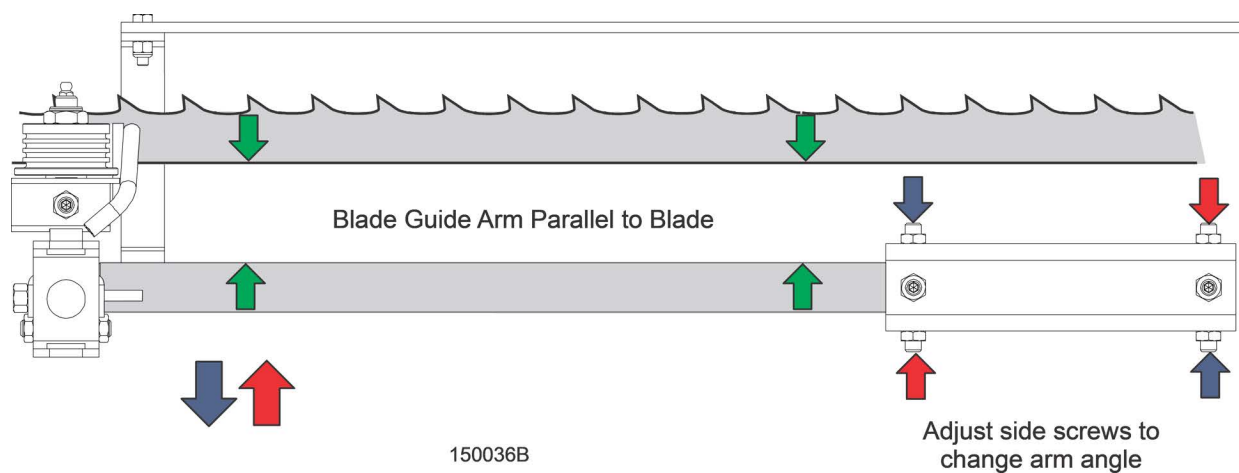

FIG. 6-1

4. Measure the distance between the blade guide arm and back edge of the blade. Adjust the appropriate side screws on the blade guide arm housing so the arm measures the same distance from the blade at both ends of the arm.
5. To move the blade guide end of the arm toward the front of the resaw, loosen jam nuts on the front inside screw and the rear outside screw. Turn the screws counterclockwise one full turn and tighten the jam nuts. Loosen the jam nuts on the front outside screw and the rear inside screw. Turn the screws clockwise until they touch the arm, back off 1/4" turn, and tighten the jam nuts.

- To move the blade guide end of the arm toward the rear of the resaw, loosen jam nuts on the front outside screw and the rear inside screw. Turn the screws counterclockwise one full turn and tighten the jam nuts. Loosen the jam nuts on the front inside screw and the rear outside screw. Turn the screws clockwise until they touch the arm, back off 1/4" turn, and tighten the jam nuts.

Blade Guide Deflection

Perform the following steps to achieve proper blade deflection with the blade guides.

- Raise the saw head until the blade is 6" (150 mm) above the conveyor belt. Measure the actual distance with a tape from the top of the belt to the bottom of the blade.
- Make sure the two vertical adjustment set screws are threaded into the blade guide shaft until they touch each other.

Loosen the bottom jam nut and tighten the top jam nut until the blade guide deflects the blade down until the bottom of the blade measures 5 3/4" (144 mm) from the conveyor belt.

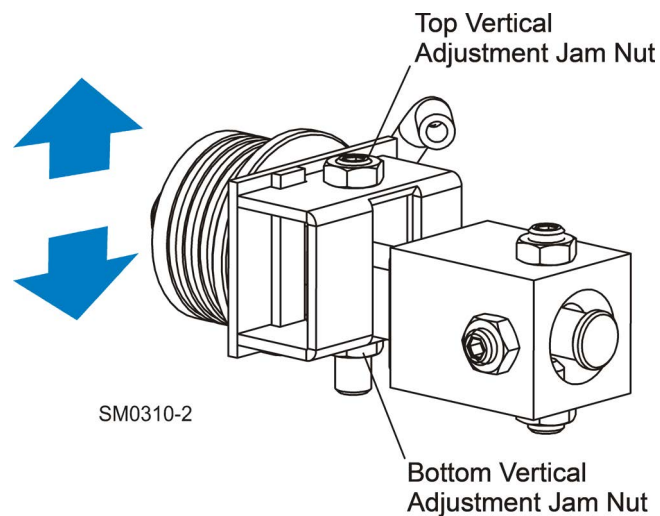

FIG. 6-1

- Repeat for the other blade guide.

NOTE: Be sure that the blade guide deflector rod clears the blade on both guide assemblies. The rod on the outer guide assembly should be checked with the arm all the way in and all the way out.

Blade Guide Vertical Tilt Alignment

The blade guides should be adjusted properly in the vertical plane. If the blade guides are tilted vertically, the blade will try to travel in the tilted direction.

A Blade Guide Alignment Tool (BGAT) is provided to help you measure the vertical tilt of the blade.

- Open the adjustable blade guide arm 1/2" (15 mm) from full open.
- Clamp the alignment tool on the blade. Position the tool close to the outer blade guide roller. Be sure the tool does not rest on a tooth or burr, and is lying flat on the blade.

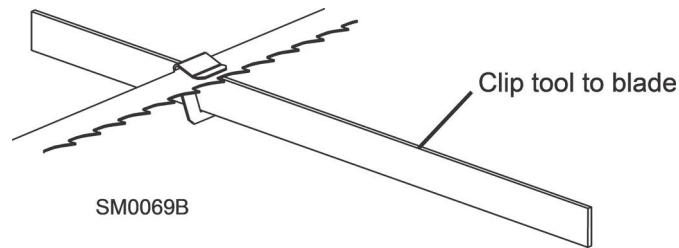

FIG. 6-1

3. Measure from the bottom of the tool to the top surface of the conveyor belt at the front and rear ends of the tool.
4. If the measurement from the tool to the belt is not equal within 1/32" (.75 mm), adjust the vertical tilt of the outer blade guide roller.
5. Loosen one set screw at the side of the blade guide assembly.

Loosen the jam nuts on the top and bottom vertical tilt adjustment screws. To tilt the roller up, loosen the bottom screw and tighten top screw. To tilt the roller down, loosen the top screw and tighten the bottom screw. Tighten the jam nuts and recheck the tilt of the blade.

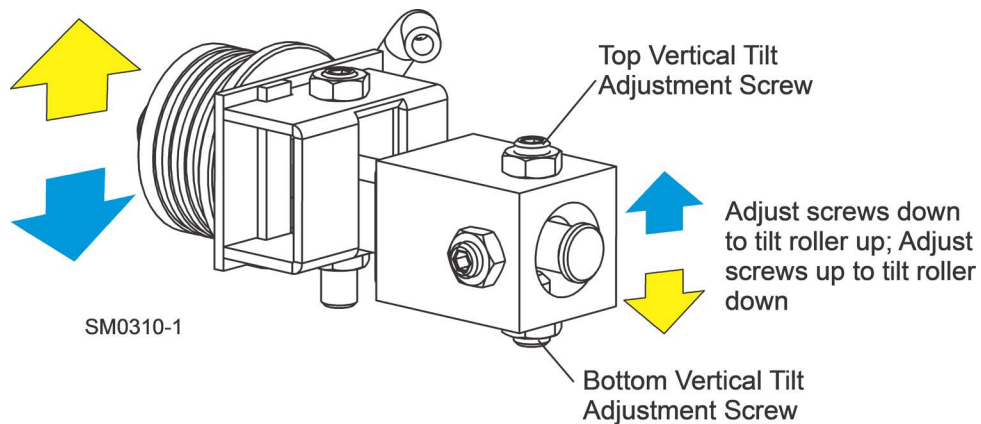

FIG. 6-1

6. Move the blade guide alignment tool close to the inner blade guide roller assembly and repeat the above steps. Adjust the vertical tilt of the inner blade guide if necessary.
7. After adjusting the vertical tilt of the blade guides, recheck the blade deflection and adjust if necessary.

Blade Guide Horizontal Tilt Adjustment

If the blade guides are tilted in the wrong direction horizontally, the back of the blade may contact the flange as the roller is spinning down, causing it to push the blade away from the guide roller.

1. Remove the blade guide alignment tool from the blade and adjust the blade guide arm halfway in.
2. Remove the clip from the blade guide alignment tool. Place the tool against the face of the outer blade guide roller.

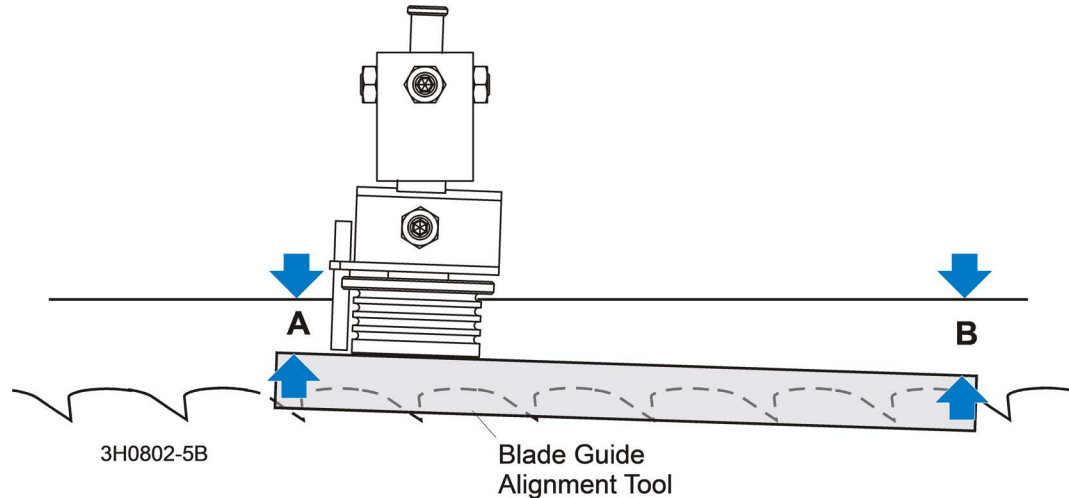
FIG. 6-1

3. Measure between the back edge of the blade and the tool at the end closest to the inner blade guide ("B").
4. Measure between the back edge of the blade and the other end of the tool ("A").

The roller should be tilted slightly to the left ('A' 1/8" [3 mm] less than 'B' ±1/8" [3 mm]).

Loosen the jam nuts on the horizontal tilt adjustment screws. To tilt the roller left, loosen the right screw and tighten left screw. To tilt the roller right, loosen the left screw and tighten the right screw. Tighten the jam nuts and recheck the tilt of the blade.

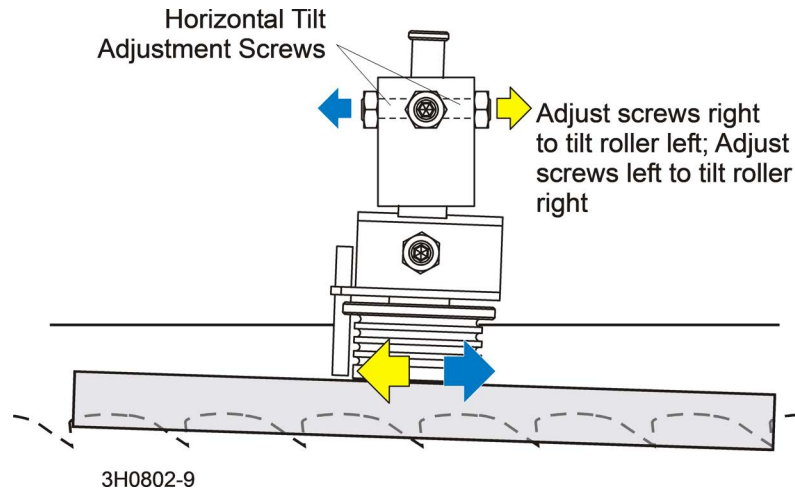
FIG. 6-1

5. Repeat the above steps for the inner blade guide roller assembly.

NOTE: Once the blade guides have been adjusted, any cutting variances are most likely caused by the blade. [See Blade Handbook, Form #600.](#)

Blade Guide Flange Spacing

Each blade guide must be adjusted so the roller flange is the correct distance from the back edge of the blade. If the flange is too close to or too far from the blade, the resaw will not cut accurately.

HINT: When adjusting blade guide spacing, loosen the top set screw and one side set screw only. This will ensure horizontal and vertical tilt adjustments are maintained when the adjustment screws are retightened.

1. Measure the distance between the flange on the outer blade guide roller to the back edge of the blade. This distance should measure 1/8" (3.0 mm). Adjust the roller back or forward if necessary.

Loosen the top and one side screw shown. Tap the blade guide forward or backward until properly positioned. Retighten the screws and jam nuts.

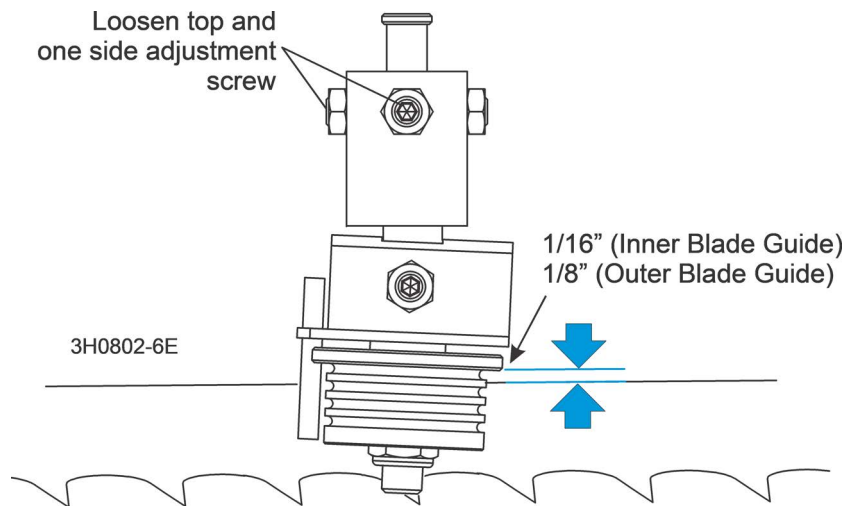

FIG. 6-1

2. Measure the distance between the flange on the inner blade guide roller to the back edge of the blade. This distance should measure 1/16" (1.5 mm). Adjust the roller back or forward if necessary.

Blade Height Scale Adjustment

After the entire resaw has been aligned and all adjustments made, check that the blade height scale indicates the true distance from the blade to the bed rails.

1. Measure from the bottom edge on a down-set tooth of the blade to the top of the feed conveyor belt, near the inner blade guide assembly.
2. View the blade height scale with eyes level with the indicator. The scale should indicate the actual distance from the blade to the belt. Adjust the indicator if necessary.

Loosen the indicator bracket mounting nut. Adjust the bracket up or down until the indicator is aligned with the correct mark on the scale (+0 -1/32 [0.8 mm]). Retighten the indicator mounting nut.

For example, if the measurement from the down-set tooth of the blade to the belt was 4 3/4", make sure the indicator reads 4 3/4" on the scale.

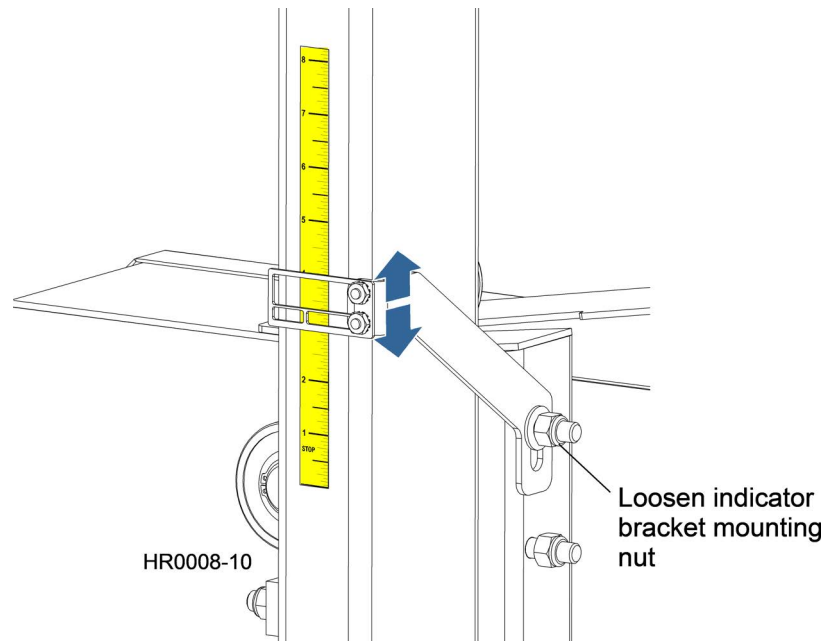

FIG. 6-2

Conveyor Belt Alignment

If the conveyor belt begins to slip, perform the following steps to tighten the belt:

1. Loosen the tensioner locking bolts on both sides of the frame. Loosen the outer jam nut on each adjustment bolt. Use a wrench to hold the adjustment bolt and turn the inner jam nut clockwise to push the conveyor belt roller out. Turn the

adjustment bolts on each side of the frame equally. Only tighten the belt until it no longer slips. Retighten outer jam nuts and the locking bolts.

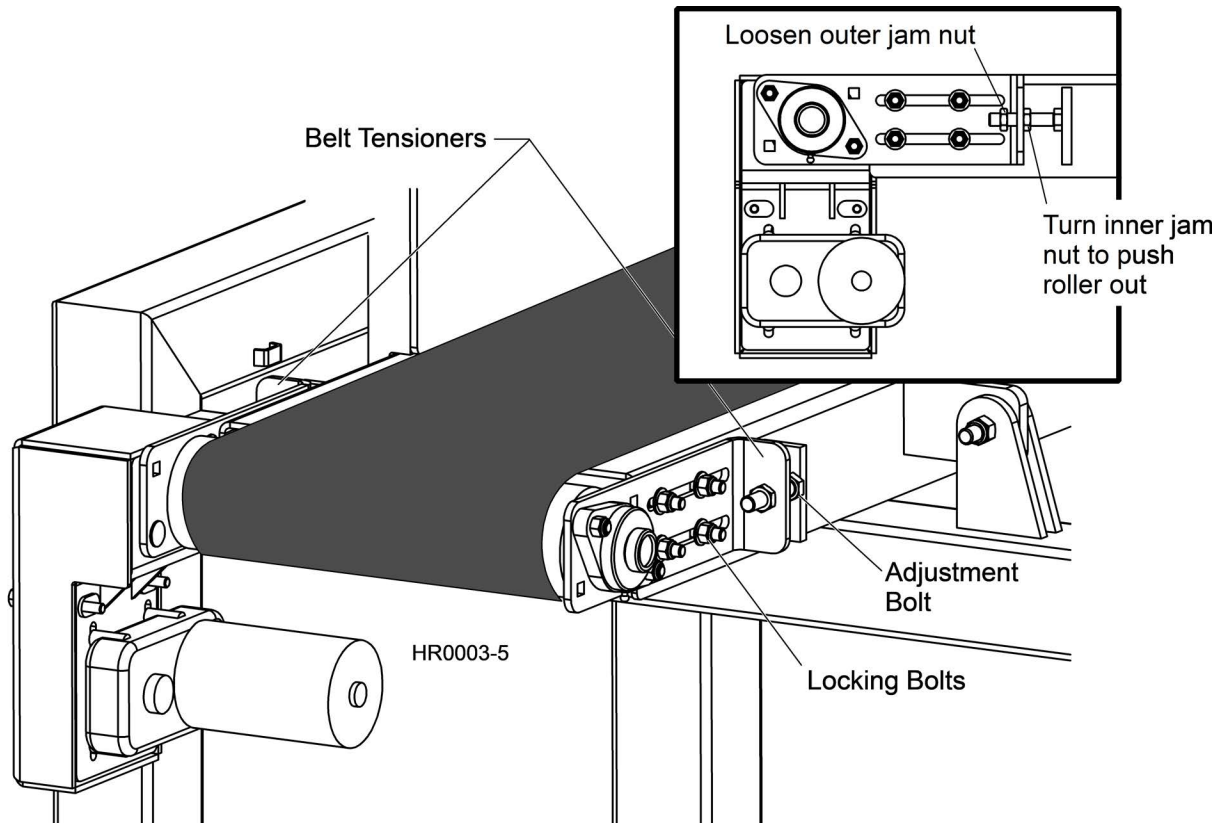

FIG. 6-2

2. After tightening the belt, run the belt for a few minutes and make sure the belt remains centered on the drive rollers while running. If the conveyor belt keeps traveling to one side or the other, loosen the belt tensioner locking bolts on one side of the belt. Use a wrench to hold the alignment bolt and adjust the jam nuts to move the end of the roller in or out.

Example: If the belt is tracking to the left, extend the left tensioner bracket out to move the belt to the right. Adjust in small increments until the belt travels straight. Retighten the locking nuts.

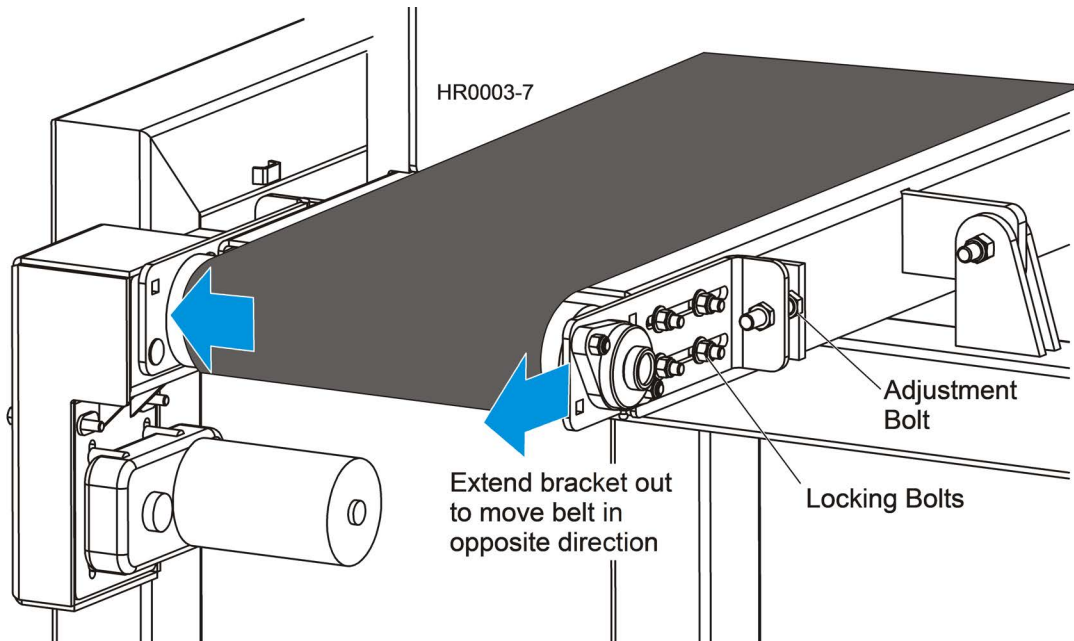

FIG. 6-3

Periodically check the conveyor belt for wear. Replace a damaged or worn belt as needed.

AR Always check the conveyor belt alignment after installing a new belt. Align the conveyor belt after replacing as necessary.

SECTION 7 ELECTRICAL INFORMATION

See [Appendix HR120/HR130 Electrical Information \(Form #2224\)](#) for complete electrical information including electrical component lists, electrical component layouts and wiring diagrams.