

## **ELECTRICAL INFORMATION**

**HR120**

**Rev. A4.07+**

**HR130EC15-1**

**Rev. A6.02-A6.04**

**HR130EB15-1**

**Rev. A6.02-A6.04**

## **APPENDIX A ELECTRICAL INFORMATION**

**HR120**

**Rev. A4.07+**

# 1.1 Schematic

## HR120G18

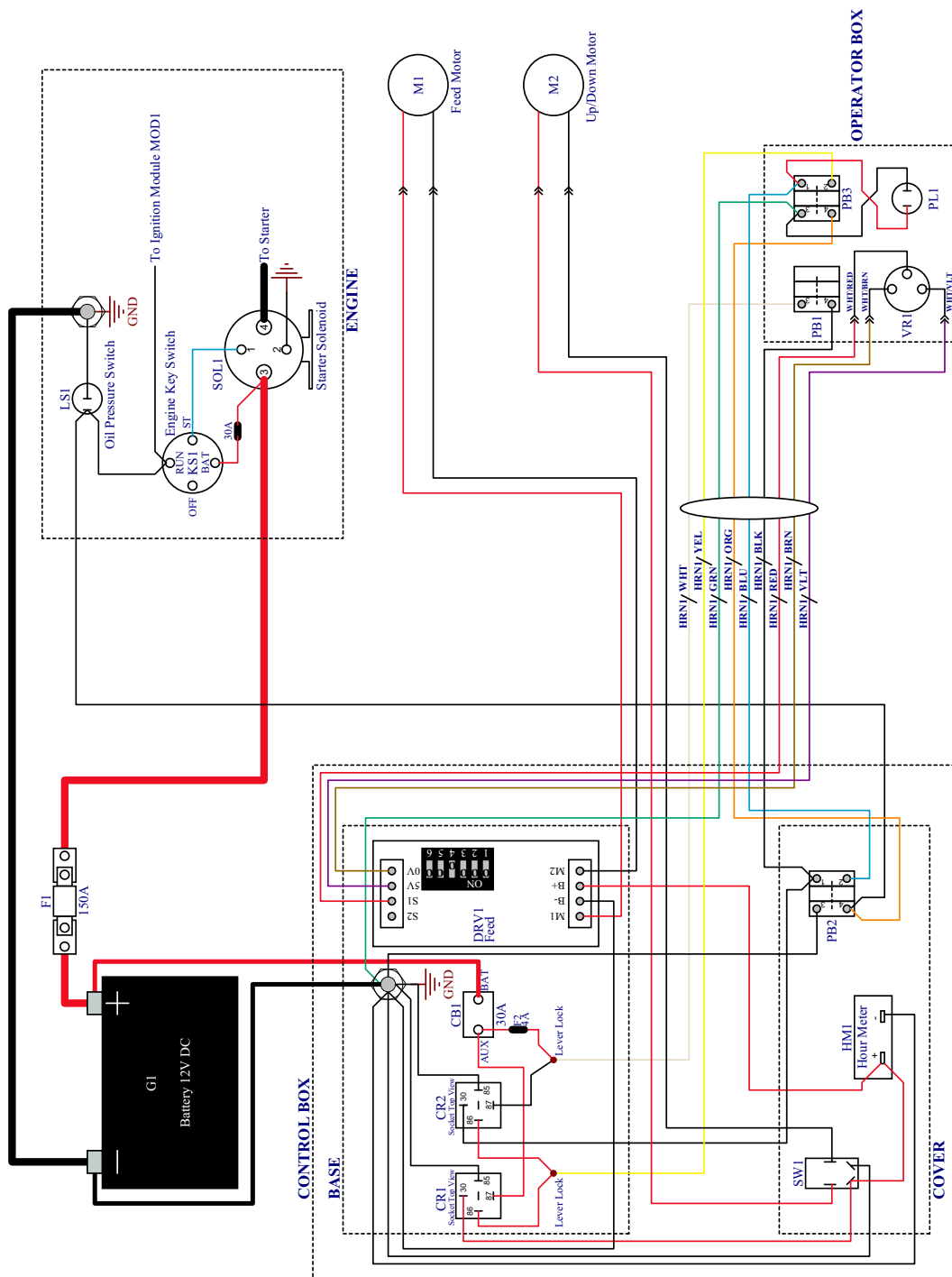

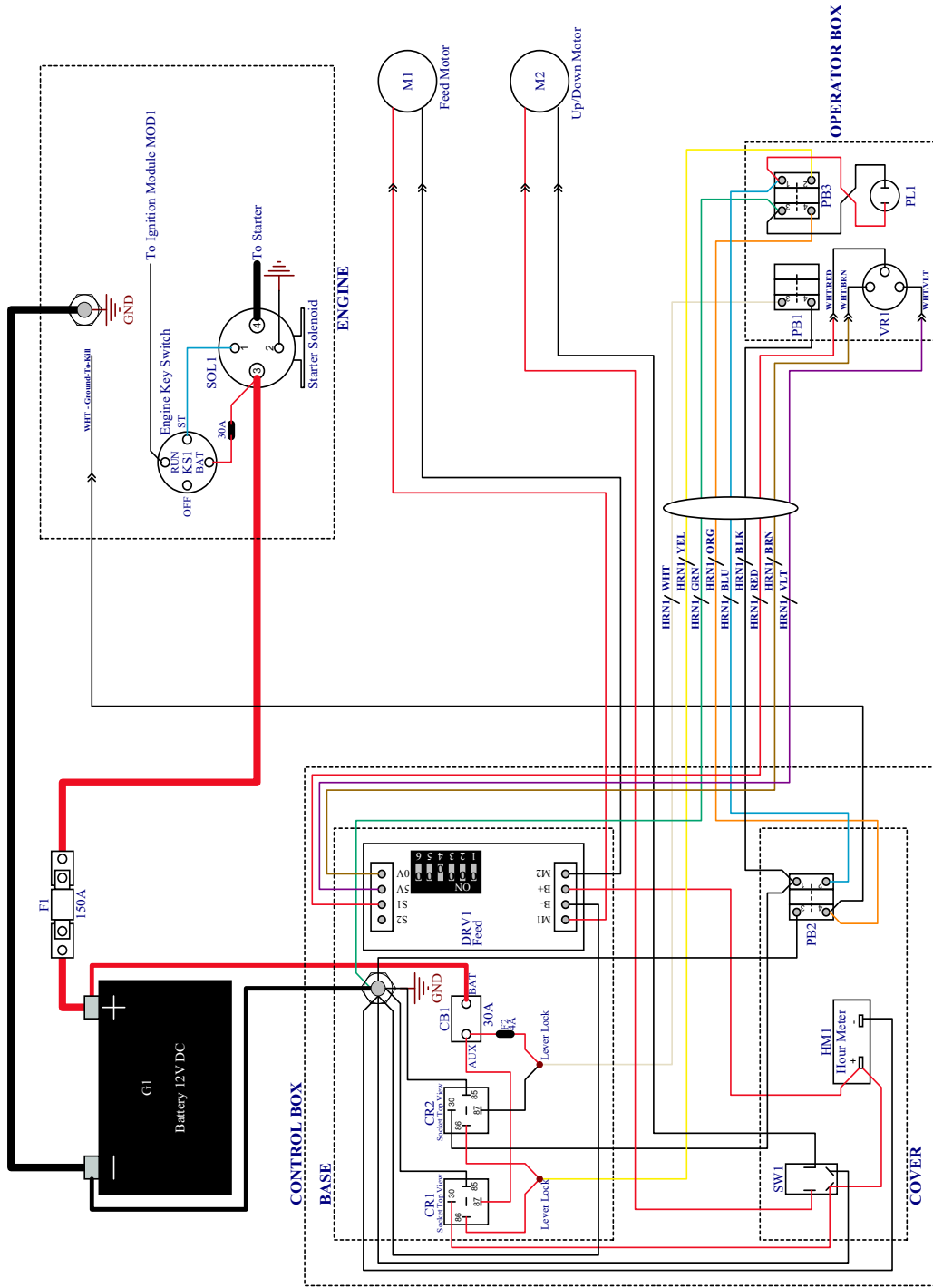

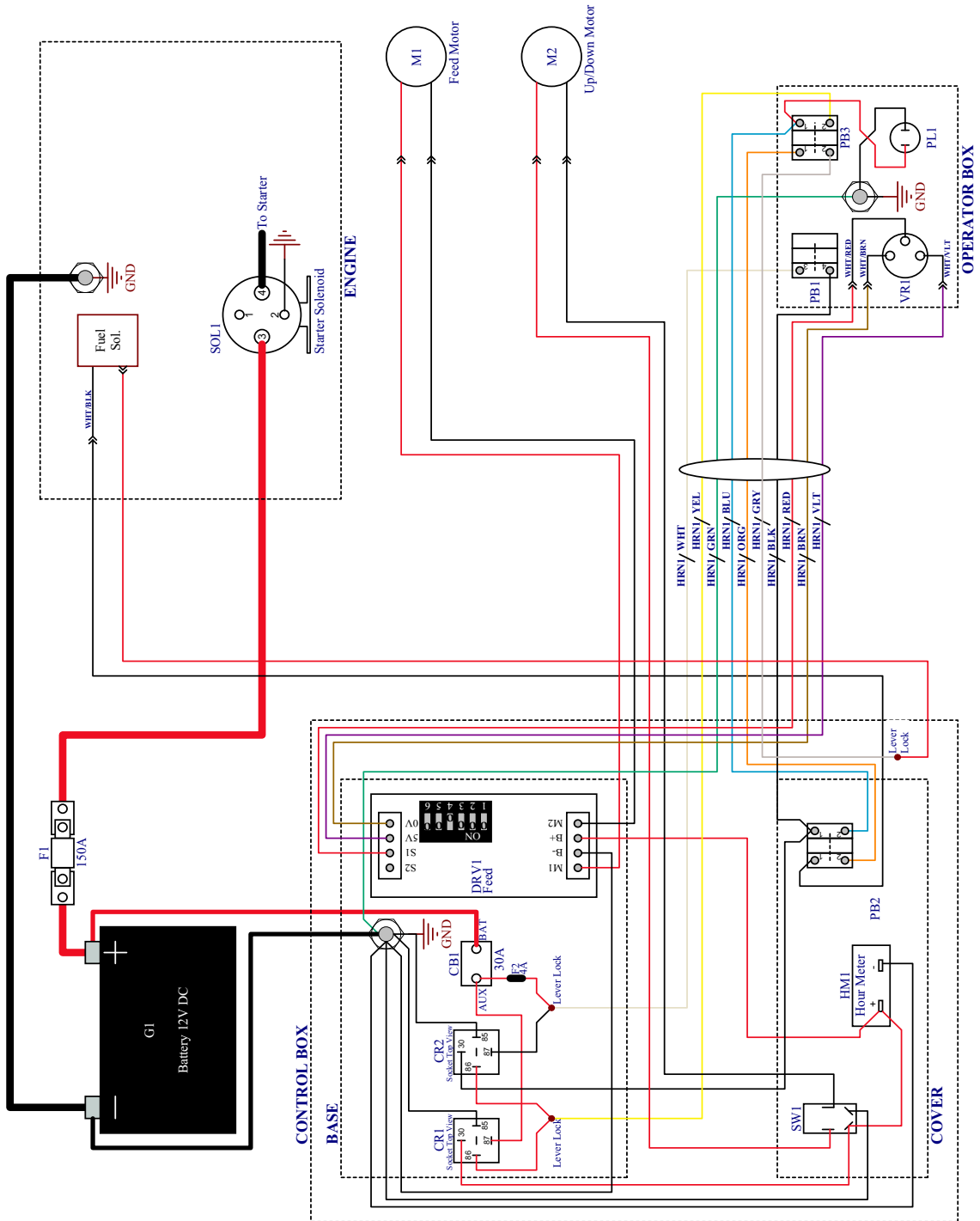

HR120EA10

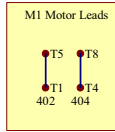
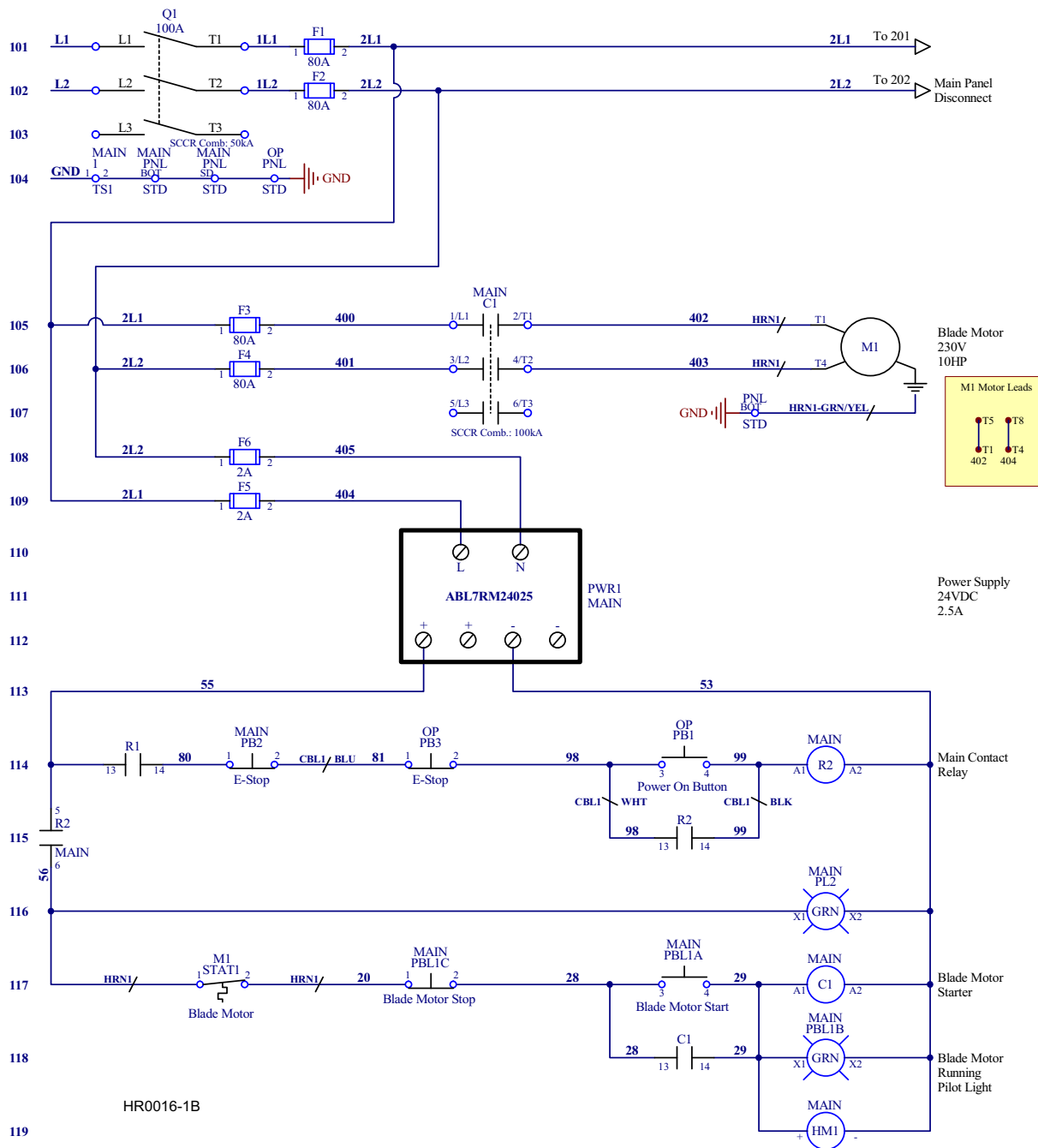

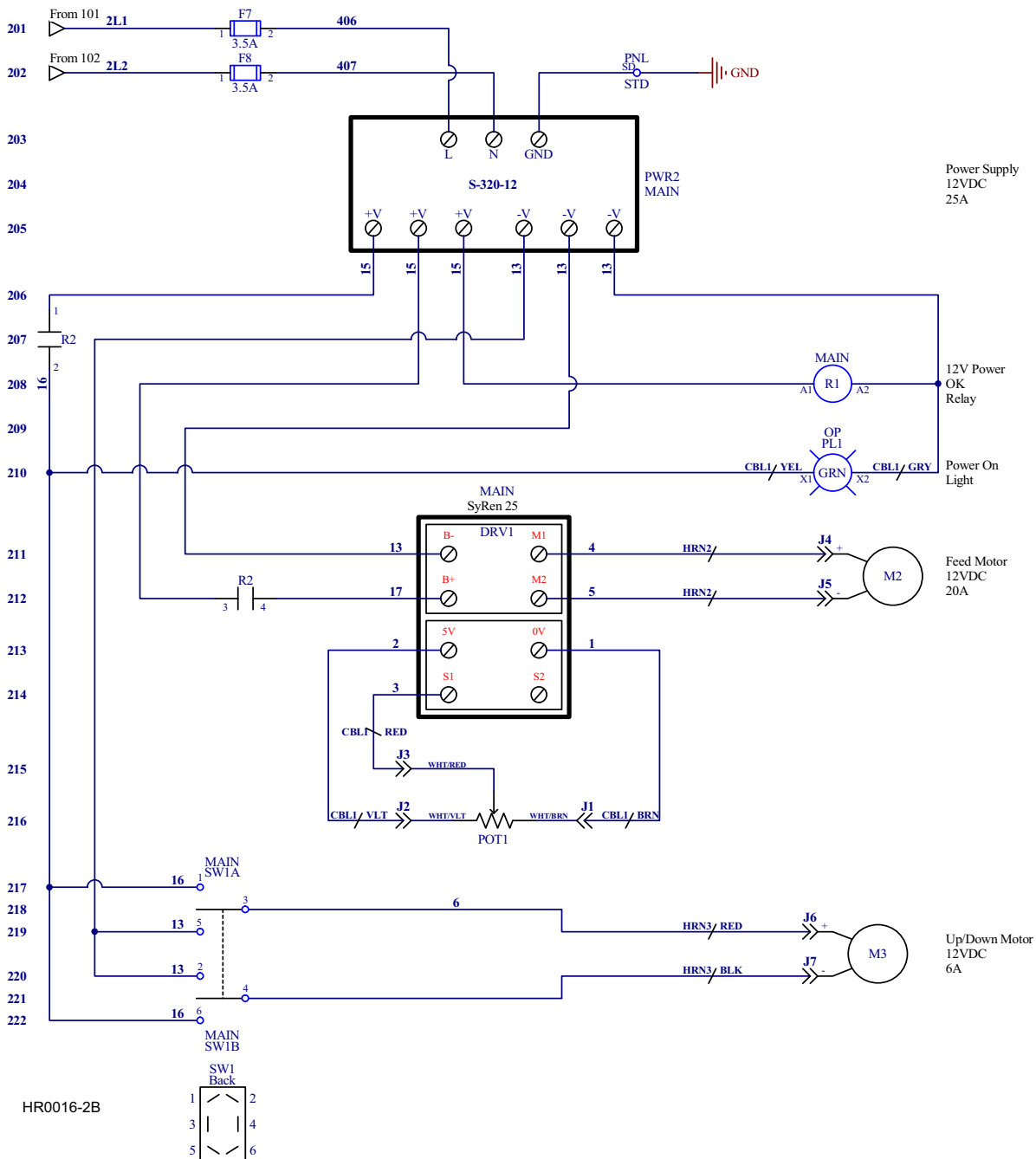

## 1.2 Component Layout

*HR120G18*  
*HR120G25*  
*HR120D17*

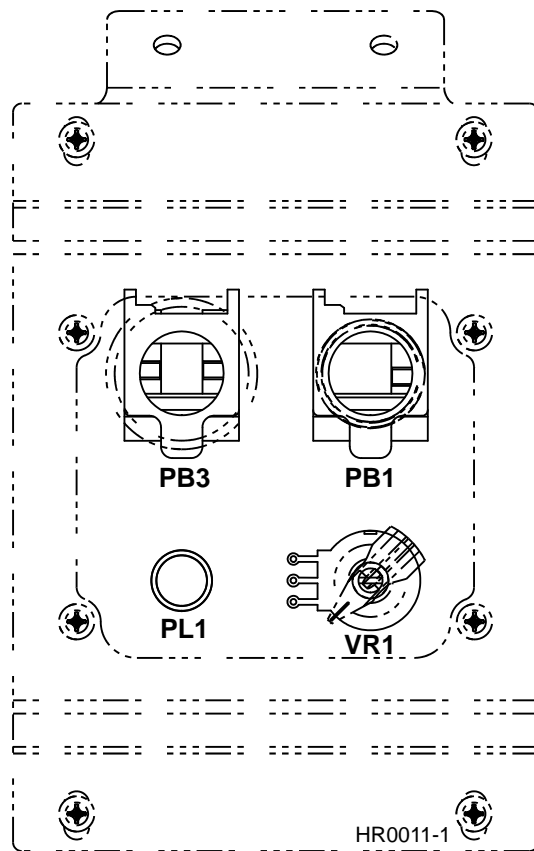

**FEED CONTROL**

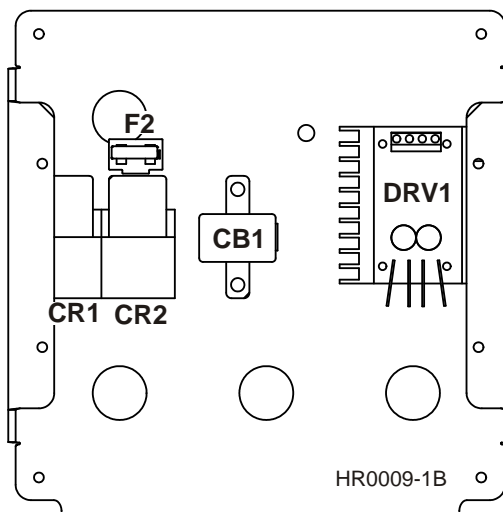
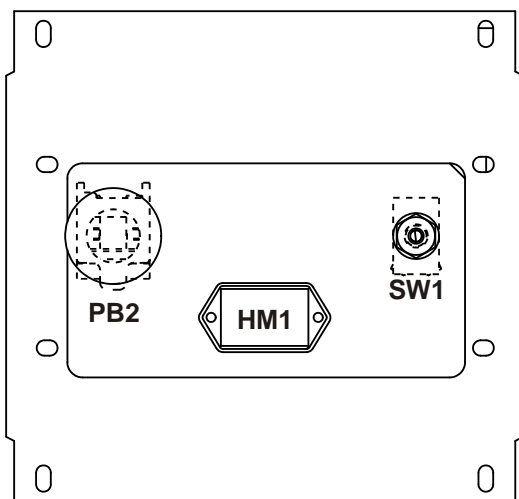

**UP/DOWN CONTROL**



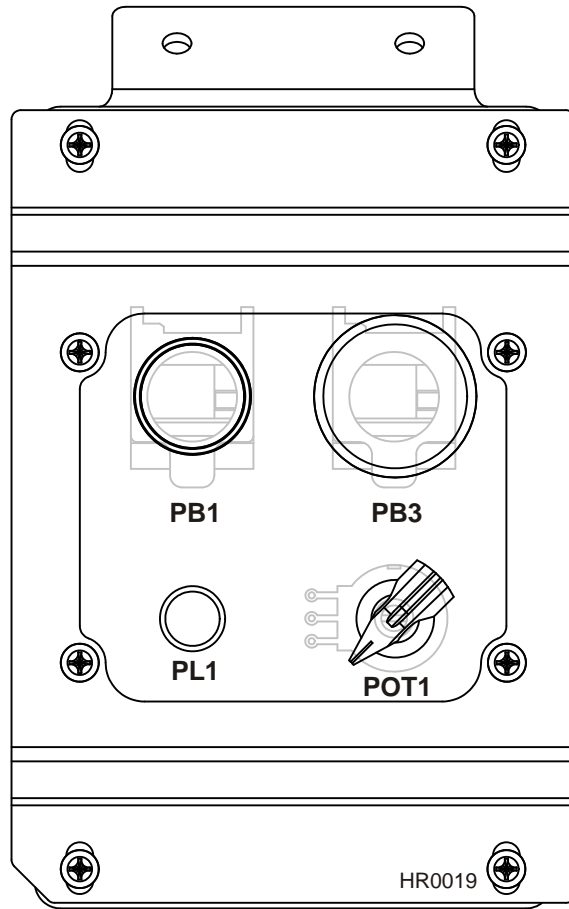

**FEED CONTROL**

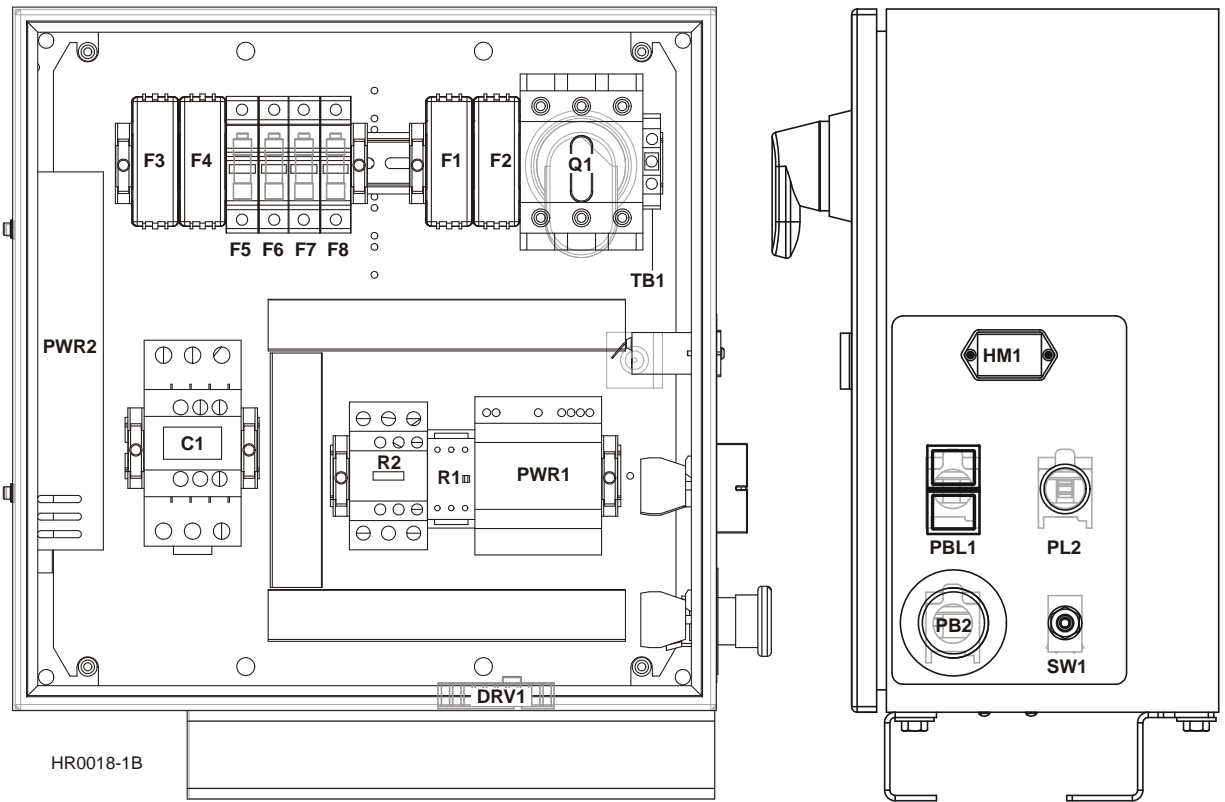

**MAIN CONTROL**

### 1.3 Motor Driver Module DIP Switch Settings (HR120 Only)

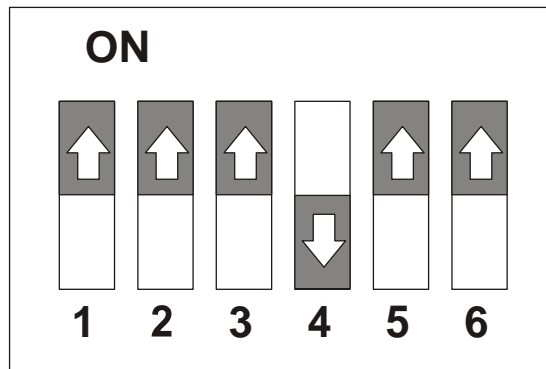

HR0023

## 1.4 Component List

### HR120G18

Component List		
Item	Wood-Mizer Part No.	Description
30A	024150-30	Fuse, 30A ATO Blade Green
CB1	E20431	Breaker, 30A Manual Reset Circuit
CR1, CR2	051335	Relay, ISO 12V Coil w/Diode
DRV1	057829-FR	Driver Kit, 25A DC Motor Field Replacement
F1	052370-150	Fuse Link, 150 Amp, 250 Volt
F2	052354	Fuseholder, ATO 16AWG w/20" Red Wires
	024150-4	Fuse, 4A ATO Pink
G1	028004	Battery, 600U 12 Volt DC
HM1	015401	Hour Meter, 12 Volt DC
KS1	---	Switch, Kohler Key
LS1	051992	Switch, Kohler Oil Pressure
M1	053578	Motor Assembly, HR120 Feed
M2	053577	Motor Assembly, HR120 Up/Down
MOD1	---	Module, Kohler Ignition (G15)
PB1	050152	Switch Head, Green Guarded
	025242	Switch Body, 22mm 1NO XB4
PB2, PB3	024945	Switch Head, Red Push Button 22mm XB4
	050527	Switch Body, 22mm 1NC 1NO ZB4
PL1	E20483	Light, Green 12V .187 Tabs
SOL1	038425	Solenoid, Kohler Starter
SW1	024200	Switch, DPDT 21A Reverse Mom. Spade Toggle
VR1	053572	Switch Assembly, HR120 Feed Rate Pot
	P06257	Knob, Speed Control
---	052293	Junction Block, 3-Position Wire Clamp (Qty. 2)

## HR120G25

<b>Component List</b>		
<b>Item</b>	<b>Wood-Mizer Part No.</b>	<b>Description</b>
<b>30A</b>	024150-30	Fuse, 30A ATO Blade Green
<b>CB1</b>	E20431	Breaker, 30A Manual Reset Circuit
<b>CR1, CR2</b>	051335	Relay, ISO 12V Coil w/Diode
<b>DRV1</b>	057829-FR	Driver Kit, 25A DC Motor Field Replacement
<b>F1</b>	052370-150	Fuse Link, 150 Amp, 250 Volt
<b>F2</b>	052354	Fuseholder, ATO 16AWG w/20" Red Wires
	024150-4	Fuse, 4A ATO Pink
<b>G1</b>	028004	Battery, 600U 12 Volt DC
<b>HM1</b>	015401	Hour Meter, 12 Volt DC
<b>KS1</b>	---	Switch, Kohler Key
<b>M1</b>	053578	Motor Assembly, HR120 Feed
<b>M2</b>	053577	Motor Assembly, HR120 Up/Down
<b>MOD1</b>	---	Module, Kohler Ignition
<b>PB1</b>	050152	Switch Head, Green Guarded
	025242	Switch Body, 22mm 1NO XB4
<b>PB2, PB3</b>	024945	Switch Head, Red Push Button 22mm XB4
	050527	Switch Body, 22mm 1NC 1NO ZB4
<b>PL1</b>	E20483	Light, Green 12V .187 Tabs
<b>SOL1</b>	---	Solenoid, Kohler Starter
<b>SW1</b>	024200	Switch, DPDT 21A Reverse Mom. Spade Toggle
<b>VR1</b>	053572	Switch Assembly, HR120 Feed Rate Pot
	P06257	Knob, Speed Control
<b>---</b>	052293	Junction Block, 3-Position Wire Clamp (Qty. 2)

## HR120D17

<b>Component List</b>		
<b>Item</b>	<b>Wood-Mizer Part No.</b>	<b>Description</b>
<b>CB1</b>	E20431	Breaker, 30A Manual Reset Circuit
<b>CR1, CR2</b>	051335	Relay, ISO 12V Coil w/Diode
<b>DRV1</b>	057829-FR	Driver Kit, 25A DC Motor Field Replacement
<b>F1</b>	052370-150	Fuse Link, 150 Amp, 250 Volt
<b>F2</b>	052354	Fuseholder, ATO 16AWG w/20" Red Wires
	024150-4	Fuse, 4A ATO Pink
<b>G1</b>	028004	Battery, 600U 12 Volt DC
<b>HM1</b>	015401	Hour Meter, 12 Volt DC
<b>M1</b>	053578	Motor Assembly, HR120 Feed
<b>M2</b>	053577	Motor Assembly, HR120 Up/Down
<b>PB1</b>	050152	Switch Head, Green Guarded
	025242	Switch Body, 22mm 1NO XB4
<b>PB2, PB3</b>	024945	Switch Head, Red Push Button 22mm XB4
	025161	Switch Body, 22mm 1NC ZB4
	050540	Contact, NC ZBE102
<b>PL1</b>	E20483	Light, Green 12V .187 Tabs
<b>SW1</b>	024200	Switch, DPDT 21A Reverse Mom. Spade Toggle
<b>VR1</b>	053572	Switch Assembly, HR120 Feed Rate Pot
	P06257	Knob, Speed Control
<b>---</b>	052293	Junction Block, 3-Position Wire Clamp (Qty. 2)

## HR120EA10

Component List		
Item	Wood-Mizer Part No.	Description
C1	053604	Contact, 65A 3P 24VDC Coil Compact
DRV1	057829-1	Driver, 25A DC Motor w/Spade Terminals
F1 - F4	053586	Fuseholder, Cube 100A
	053587	Fuse, 80A Class J Cube
F5 - F6	052512	Fuse Block, 2P Class CC 30A Ind. DIN
	E22716	Fuse, 2A 600V Class CC
F7 - F8	052512	Fuseholder, 2P Class CC Finger Safe
	052721	Fuse, 3.5A 600V Class CC Delay
HM1	015401	Hour Meter, 12 Volt DC
M1	036214	Motor, 10HP Single Phase 60Hz
M2	053578	Motor Assembly, HR120 Feed
M3	053577	Motor Assembly, HR120 Up/Down
PB1	050152	Switch Head, Green Guarded
	025242	Switch Body, 22mm 1NO XB4
PB2, PB3	024945	Switch Head, Red Push Button 22mm XB4
	025161	Switch Body, 22mm 1NC ZB4
PBL1	051746	Switch Operator, 2 Button w/Pilot Red/Green
	052501	Boot, Clear Sealing ZB Switch
	025236-31	Switch Body, 22mm Green LED 1NO 24V ZB4
	050540	Contact, NC ZBE102
PL1	E20483	Light, Green 12V .187 Tabs
PL2	024970-3	Pilot Light, Green 24V 22mm LED XB4
POT1	053572	Switch Assembly, HR120 Feed Rate Pot
	P06257	Knob, Speed Control
PWR1	053591	Power Supply, 24VDC 60W
PWR2	053592	Power Supply, 12VDC 320W
Q1	050906-1	Disconnect, 100Amp 3P Non-Fused 6mm
	050907-1	Operator, Red/Yellow Pistol Grip 6mm
	050908-1	Shaft, Pistol Grip Disconnect 290mm x 6mm
R1	053590	Relay, Control 12VDC 2NO
R2	052465	Contact, 32A 3P 24VDC Coil
SW1	024200	Switch, DPDT 21A Reverse Mom. Spade Toggle
TB1	053585	Terminal Block, Grounding

## **APPENDIX B ELECTRICAL INFORMATION**

**HR130EC15-1**

**Rev. A6.02-A6.04**





# Revision History

Date	Revision	Revision Record	Drawn By	Checked By
9/1/10	A1.01	Changed Power Supply Fuses For CSA	JRF	SDC
3/10/11	A2.00	Added Top Level Machines w/Setworks	JRF	SDC
11/21/13	A3.00	Setworks Software V2.0	JRF	SDC
5/28/14	A4.00	Changed Scheider Electric Terminal Blocks To Wago	JRF	SDC
9/3/15	A4.03	Added Connector To Feed Motor	JRF	JEC
9/28/15	A5.00	Change To High Efficiency Blade Motor	JRF	SDC
6/24/16	A6.00	Setworks Software V3.0	JRF	SDC
10/31/16	A6.01	Added Terminal Block For PLC Output V+ Connection	JRF	SDC

**Wood-Mizer®**

Project Description: HR130EC15-1

Revision:	A6.02	Pg Desc:	Revision History
Mounting Location:	+	Type:	Overview
Prev. pg:	A1	Page:	B1
Next pg:	+MAIN/1	Total Pgs:	22

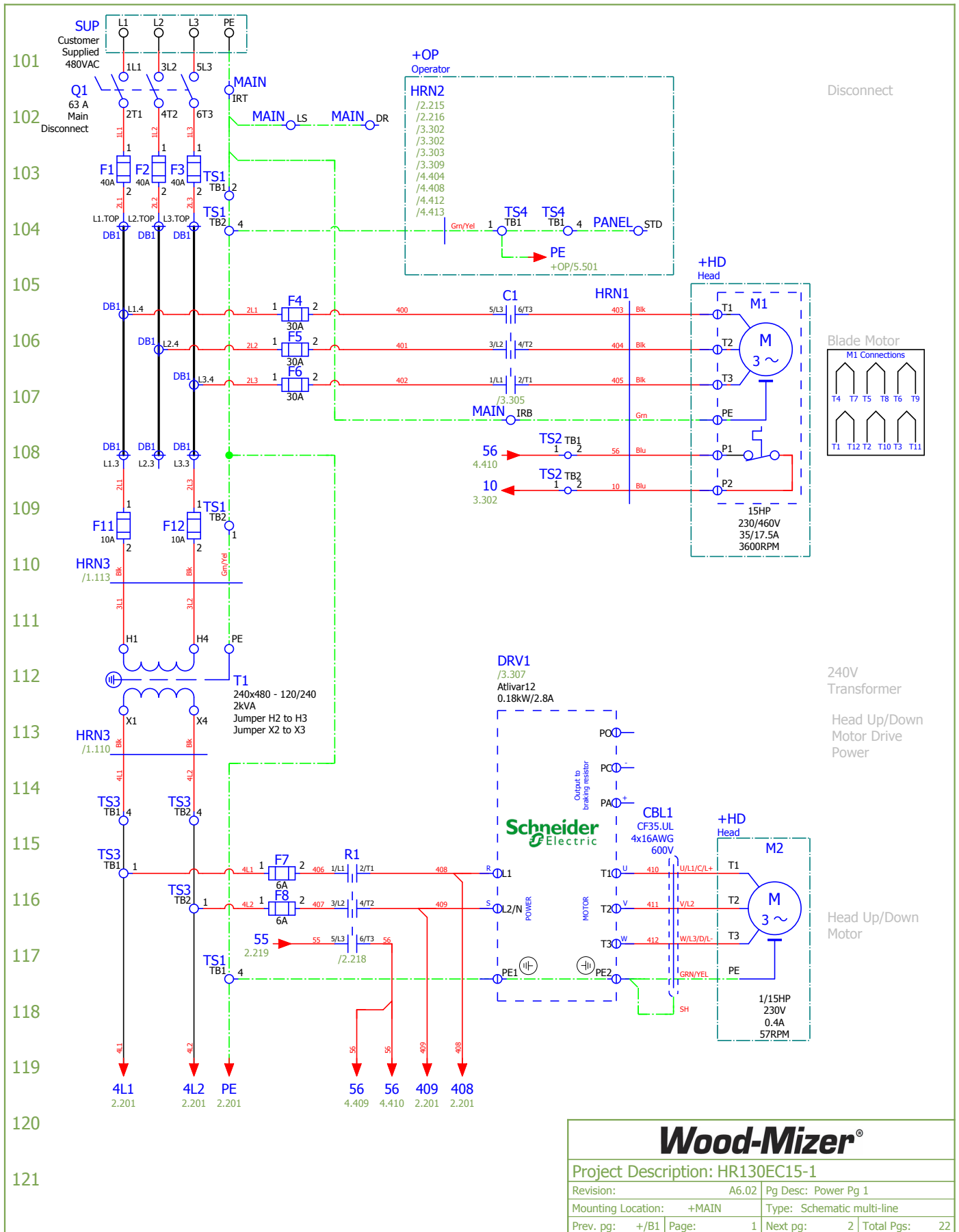

# Wood-Mizer®

Project Description: HR130EC15-1			
Revision:	A6.02	Pg Desc:	Power Pg 1
Mounting Location:	+MAIN	Type:	Schematic multi-line
Prev. pg:	+/B1	Page:	1
		Next pg:	2
		Total Pgs:	22

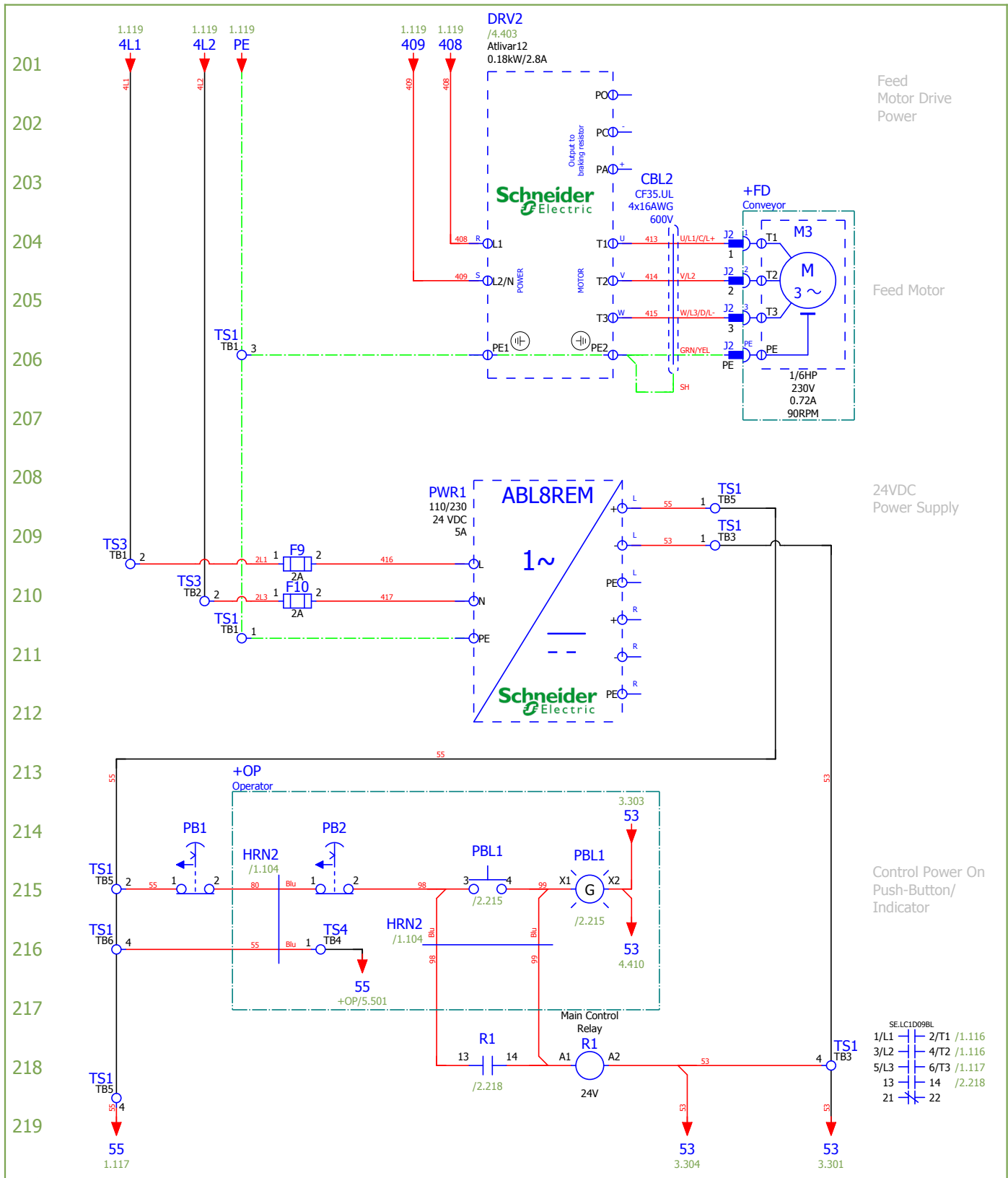

# Wood-Mizer®

Project Description: HR130EC15-1			
Revision:	A6.02	Pg Desc: Power Pg 2	
Mounting Location:	+MAIN	Type: Schematic multi-line	
Prev. pg.:	1	Page:	2
		Next pg.:	3
		Total Pgs.:	22

301  
302  
303  
304  
305  
306  
307  
308  
309  
310  
311  
312  
313  
314  
315  
316  
317  
318  
319  
320  
321

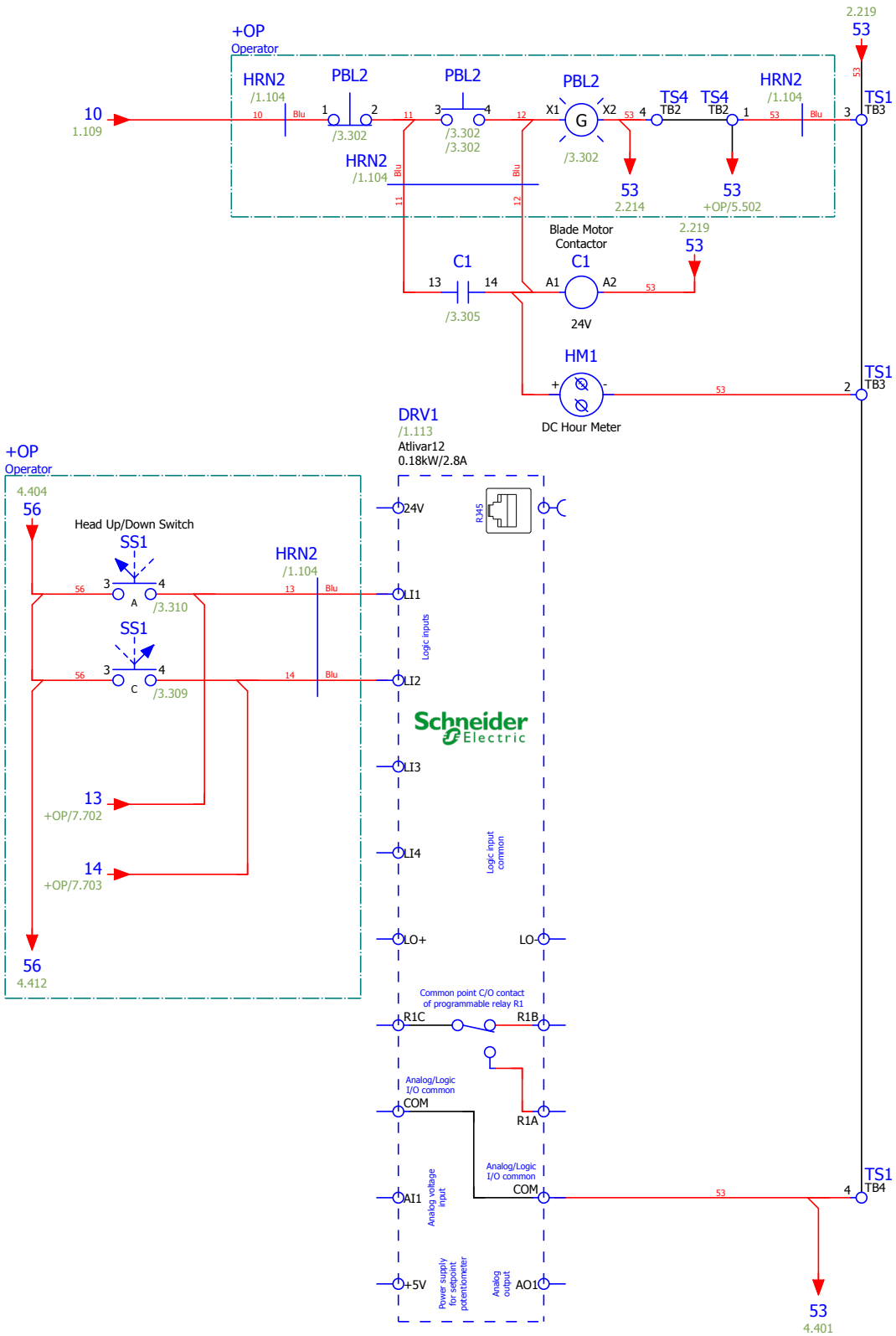

Blade Motor Start/Stop Push-Button/Indicator

SE.LCID25BD  
1/L1 2/T1 /1.107  
3/L2 4/T2 /1.106  
5/L3 6/T3 /1.106  
13 14 /3.305  
21 22

Blade Motor Hour Meter

Head Up/Down Motor Drive Control

Head Up

Head Down

<b>Wood-Mizer®</b>			
Project Description: HR130EC15-1			
Revision:	A6.02	Pg Desc: Control Pg 1	
Mounting Location:	+MAIN	Type: Schematic multi-line	
Prev. pg:	2	Page:	3
		Next pg:	4
		Total Pgs:	22

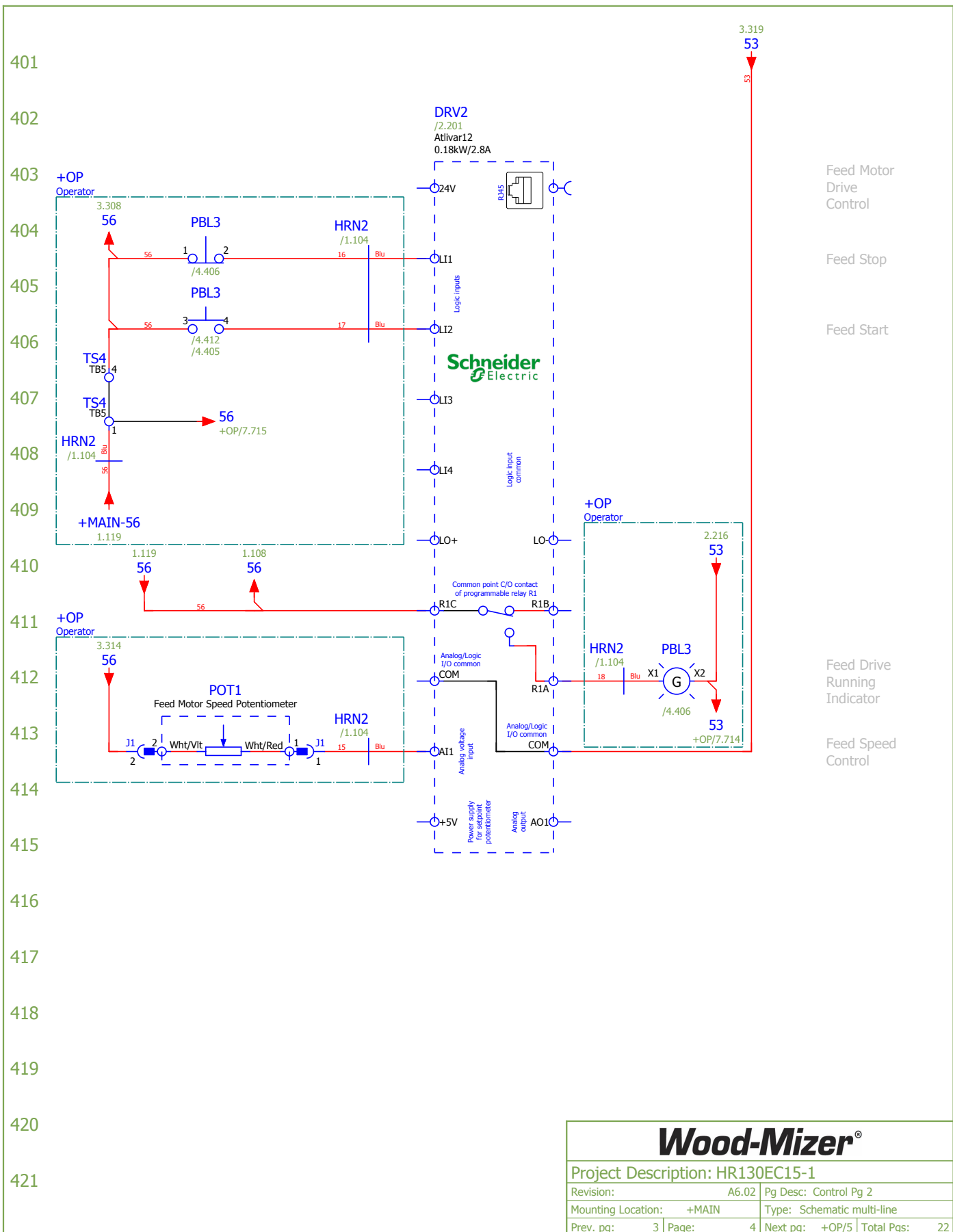

# Wood-Mizer®

Project Description: HR130EC15-1			
Revision:	A6.02	Pg Desc: Control Pg 2	
Mounting Location:	+MAIN	Type: Schematic multi-line	
Prev. pg:	3	Page:	4
		Next pg:	+OP/5
		Total Pgs:	22

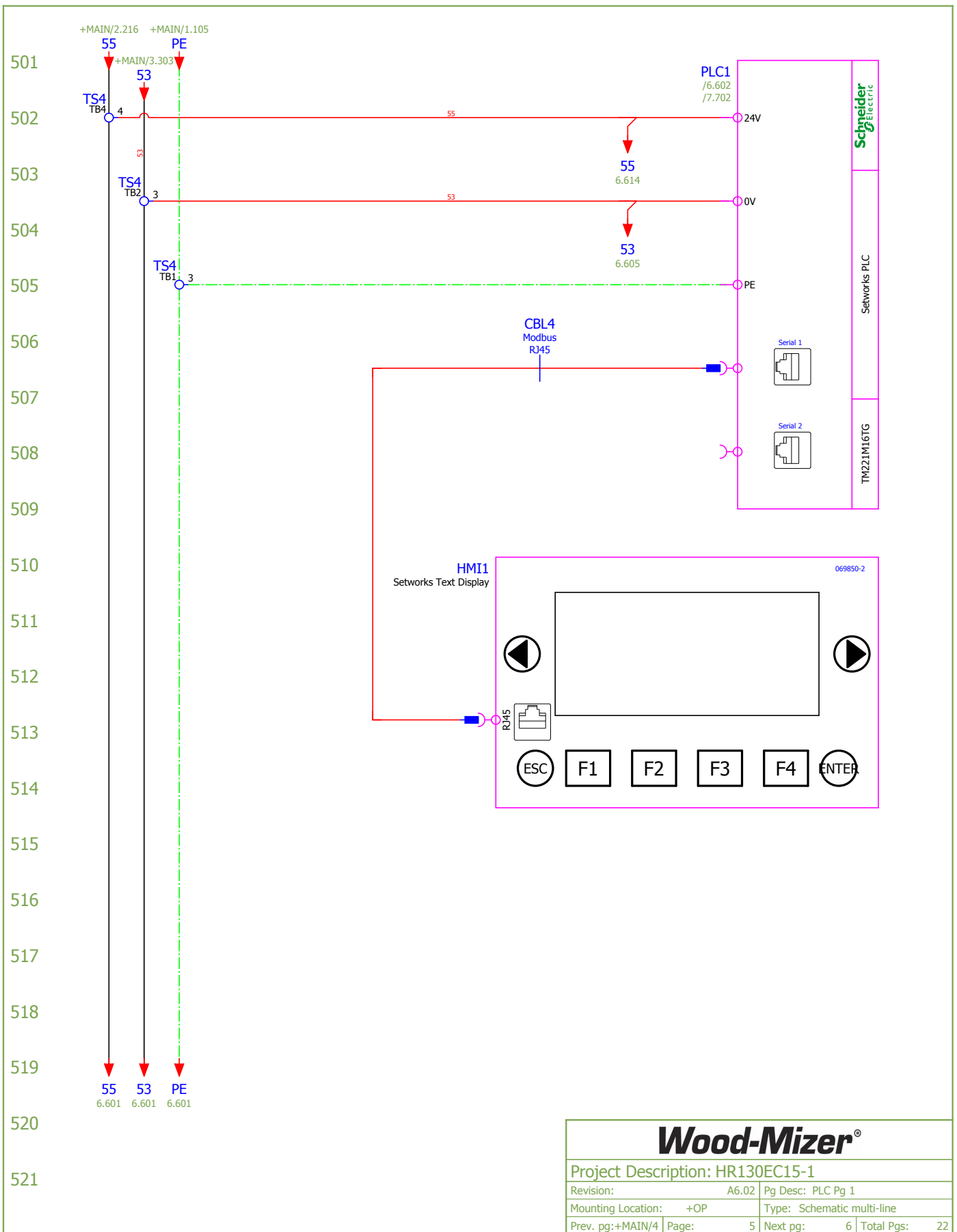

**Wood-Mizer®**

Project Description: HR130EC15-1			
Revision:	A6.02	Pg Desc:	PLC Pg 1
Mounting Location:	+OP	Type:	Schematic multi-line
Prev. pg: +MAIN/4	Page: 5	Next pg: 6	Total Pgs: 22

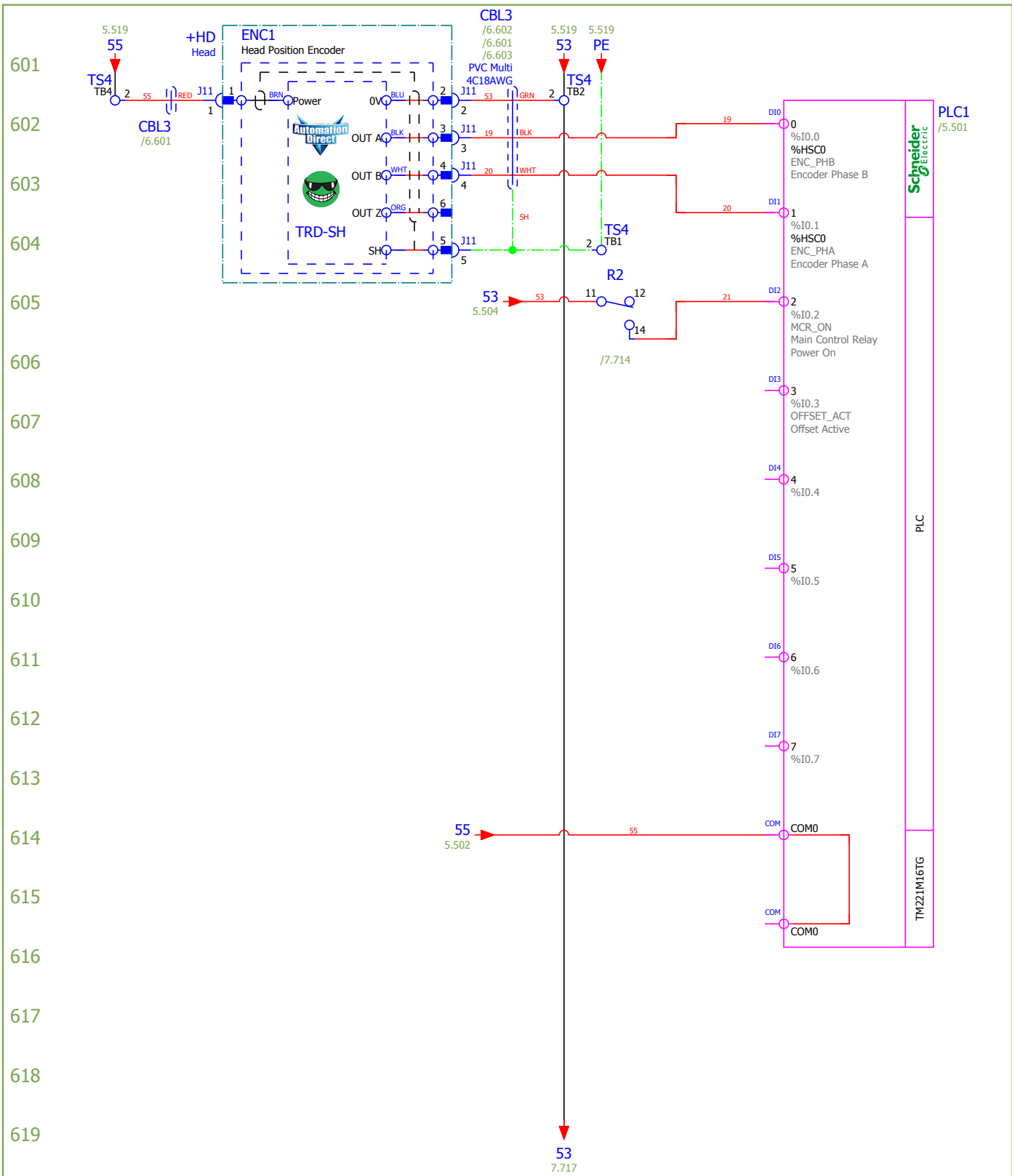

601  
602  
603  
604  
605  
606  
607  
608  
609  
610  
611  
612  
613  
614  
615  
616  
617  
618  
619  
620  
621



701  
702  
703  
704  
705  
706  
707  
708  
709  
710  
711  
712  
713  
714  
715  
716  
717  
718  
719  
720  
721

PLC1  
/5.501

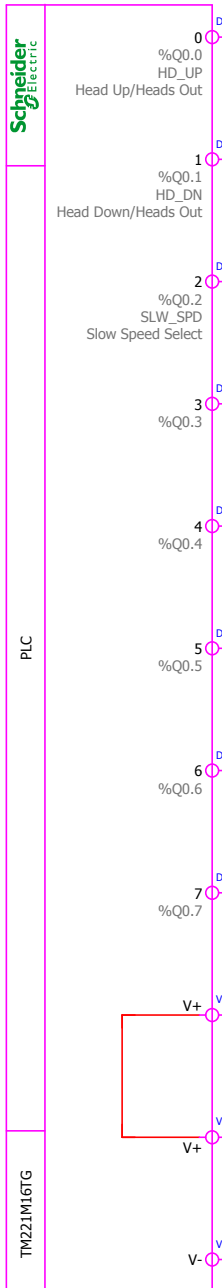

PLC

TM221M16TG

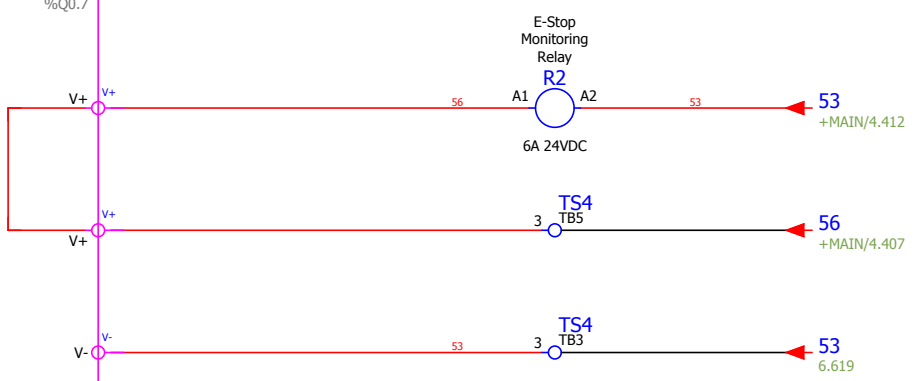
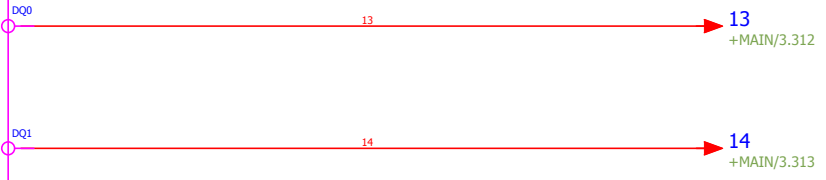

FR\_38.61.7.024.0050  
14  
12 11 /6.605

# Wood-Mizer®

Project Description: HR130EC15-1			
Revision:	A6.02	Pg Desc:	PLC Pg 3
Mounting Location:	+OP	Type:	Schematic multi-line
Prev. pg:	6	Page:	7
Next pg:+	Docs/C1	Total Pgs:	22

# Device Tag/Parts List

WM\_PARTS\_LIST-Manual

Device tag	Function	Wood-Mizer Part Number	Wood-Mizer Description	Qty.	X-Ref
C1	Blade Motor Contactor	051322	Contact, 25A 3P 24VDC Coil	1	+MAIN/3.305
DB1	Distribution Block	069701	Distribution Block, 3P 1 to 4	1	+MAIN/1.104
DRV1	Head Up/Down Motor Drive Power	069799	AC Drive Assy, HR130 Up/Down w/Software	1	+MAIN/1.113
DRV2	Feed Motor Drive Power	069800	Drive Assy, HR130 Feed w/Software	1	+MAIN/2.201
ENC1	Head Position Encoder	069840	Encoder Assy, HR130 Networks	1	+OP/6.601
F1	Main L1 Fuse	053717	Fuseholder, 60A Cube	1	+MAIN/1.103
F1	=	069702	Fuse, 40A Class J Cube	1	+MAIN/1.103
F2	Main L2 Fuse	053717	Fuseholder, 60A Cube	1	+MAIN/1.103
F2	=	069702	Fuse, 40A Class J Cube	1	+MAIN/1.103
F3	Main L3 Fuse	053717	Fuseholder, 60A Cube	1	+MAIN/1.103
F3	=	069702	Fuse, 40A Class J Cube	1	+MAIN/1.103
F4	Blade Motor L1 Fuse	053736	Fuseholder, Cube 30A	1	+MAIN/1.106
F4	=	053737	Fuse, 30A Class J Cube	1	+MAIN/1.106
F5	Blade Motor L2 Fuse	053736	Fuseholder, Cube 30A	1	+MAIN/1.106
F5	=	053737	Fuse, 30A Class J Cube	1	+MAIN/1.106
F6	Blade Motor L3 Fuse	053736	Fuseholder, Cube 30A	1	+MAIN/1.107
F6	=	053737	Fuse, 30A Class J Cube	1	+MAIN/1.107
F7	Up/Down Motor Drive L1 Fuse	052512	Fuse Holder, 2P Class CC Screw Clamp	1	+MAIN/1.116
F7	=	052456	Fuse, 6A 600V Calss CC Delay	1	+MAIN/1.116
F8	Up/Down Motor Drive L2 Fuse	052456	Fuse, 6A 600V Calss CC Delay	1	+MAIN/1.116
F9	Power Supply L1 Fuse	052512	Fuse Holder, 2P Class CC Screw Clamp	1	+MAIN/2.209
F9	=	E22716	Fuse, 2A 600V Class CC	1	+MAIN/2.209
F10	Power Supply N Fuse	E22716	Fuse, 2A 600V Class CC	1	+MAIN/2.210
F11	Transformer H1 Fuse	052512	Fuse Holder, 2P Class CC Screw Clamp	1	+MAIN/1.109
F11	=	051957	Fuse, 10A 600V Class CC Delay	1	+MAIN/1.109
F12	Transformer H4 Fuse	051957	Fuse, 10A 600V Class CC Delay	1	+MAIN/1.109
HM1	Blade Motor Hour Meter	015401	Digital Meter, Hour Rect Mount w/Gasket	1	+MAIN/3.306
HMI1	Networks Text Display	069850-2	HMI Assy, PLC Networks	1	+OP/5.510
M1	Blade Motor	074780	Motor, 15HP 3520RPM Leeson Wattsaver	1	+MAIN/1.105
M2	Head Up/Down Motor	025696	Motor, 1/15HP 57RPM 230V 3PH 30:1 Gear	1	+MAIN/1.116
M3	Feed Motor	073702	Motor Assy, HR130 Feed Conveyor	1	+MAIN/2.204
PB1	Main E-Stop Push-Button	025161	Switch Body, 1NC 22mm ZB4	1	+MAIN/2.215
PB1	=	024945	Switch, PB E-Stop Maintnd Red 22mm ZB4	1	+MAIN/2.215
PB1	=	050992	Legend, E-Stop, Round Yellow	1	+MAIN/2.215
PB2	Operator E-Stop Push-Button	025161	Switch Body, 1NC 22mm ZB4	1	+MAIN/2.215
PB2	=	024945	Switch, PB E-Stop Maintnd Red 22mm ZB4	1	+MAIN/2.215
PB2	=	050992	Legend, E-Stop, Round Yellow	1	+MAIN/2.215
PBL1	Control Power On Push-Button	024974-3	Switch, PB Grn 22mm 1NO/1NC LED 24V XB4	1	+MAIN/2.215
PBL2	Blade Motor Start/Stop Push-Button	025236-31	Switch Body, 22mm Grn LED 1 NO 24V ZB4	1	+MAIN/3.302
PBL2	=	051746	Switch Operator, 2 Button w/Pilot Red/Gr	1	+MAIN/3.302
PBL2	=	050540	Contact, NC ZBE102	1	+MAIN/3.302
PBL2	=	052501	Boot, Clear Sealing ZB Sw	1	+MAIN/3.302
PBL3	Feed Motor Start/Stop Push-Button	025236-31	Switch Body, 22mm Grn LED 1 NO 24V ZB4	1	+MAIN/4.406
PBL3	=	051746	Switch Operator, 2 Button w/Pilot Red/Gr	1	+MAIN/4.406
PBL3	=	050540	Contact, NC ZBE102	1	+MAIN/4.406
PBL3	=	052501	Boot, Clear Sealing ZB Sw	1	+MAIN/4.406
PLC1	Networks PLC	069849-3	PLC Ass, PLC Networks	1	+OP/5.501
POT1	Feed Motor Speed Potentiometer	025200	Pot Assy, 4-20mA 24V W/conn	1	+MAIN/4.413
POT1	=	033476	O-Ring, 7/32 IN #009	2	+MAIN/4.413
POT1	=	033478	Knob, 1/4 ID Fluted Round Plastic	1	+MAIN/4.413
PWR1	24VDC Power Supply	069703	Power Supply, 24VDC 5A 110/230	1	+MAIN/2.208
Q1	Main Disconnect	050881-1	Disconnect, 63A 600V 3P 6mm Shaft	1	+MAIN/1.102
Q1	=	050908-1	Shaft, 290mm Pistol Grip Disconnect	1	+MAIN/1.102
Q1	=	050907-1	Handle, Disconnect Red/Yel Pistol Grip	1	+MAIN/1.102
R1	Main Control Relay	024890	Contact, 9A 3P 24VDC Coil	1	+MAIN/2.218
R2	E-Stop Monitoring Relay	069883	Relay, 6A 24VDC w/ Cage Clamp Socket	1	+OP/7.714
SS1	Head Up/Down Switch	050545	Base, 2NO Contact	1	+MAIN/3.309

## Wood-Mizer®

Project Description: HR130EC15-1

Revision:	A6.02	Pg Desc:	Parts list
Mounting Location:	+Docs	Type:	Parts list
Prev. pg:	+OP/7	Page:	C1
Next pg:	C2	Total Pgs:	22



# Terminal line-up diagram

Wood-Mizer\_Terminal\_Lineup\_Diagram

Terminal strip +MAIN-TS1									
Terminal				Jumper		End Plate	Remark	Terminal	
Designation	Level	P/N	Description	Diagram	Part number	Part number		X-Ref	
TB1		068104	Terminal Block, 4Pos 1.5mm GND Clamp	•					/1.03
TB2		068104	Terminal Block, 4Pos 1.5mm GND Clamp	•		068105			/1.04
TB3		068103	Terminal Block, 4Pos 1.5mm Com Clamp	●	068113		Jumper is Trimmed Down To 2 Position Jumper Between TB3-4		/2.09
TB4		068103	Terminal Block, 4Pos 1.5mm Com Clamp	●		068105			/3.18
TB5		068103	Terminal Block, 4Pos 1.5mm Com Clamp	●	068113		Jumper is Trimmed Down To 2 Position Jumper Between TB5-6		/2.09
TB6		068103	Terminal Block, 4Pos 1.5mm Com Clamp	●		068105			/2.16

**Wood-Mizer®**

Project Description: HR130EC15-1

Revision: A6.02 Pg Desc: Terminal line-up diagram

Mounting Location: +Docs Type: Terminal line-up diagram

Prev. pg: C2 Page: D1 Next pg: D2 Total Pgs: 22

# Terminal line-up diagram

Wood-Mizer\_Terminal\_Lineup\_Diagram

Terminal strip +MAIN-TS2								
Terminal				Jumper		End Plate	Remark	Terminal X-Ref
Designation	Level	P/N	Description	Diagram	Part number	Part number		
TB1		068100	Terminal Block, 2Pos 1.5mm Clamp	■				/1.08
TB2		068100	Terminal Block, 2Pos 1.5mm Clamp	■		068102		/1.09

**Wood-Mizer®**

Project Description: HR130EC15-1

Revision: A6.02 Pg Desc: Terminal line-up diagram

Mounting Location: +Docs Type: Terminal line-up diagram

Prev. pg: D1 Page: D2 Next pg: D3 Total Pgs: 22

# Terminal line-up diagram

Wood-Mizer\_Terminal\_Lineup\_Diagram

## Terminal strip +MAIN-TS3

Terminal				Jumper		End Plate	Remark	Terminal X-Ref
Designation	Level	P/N	Description	Diagram	Part number	Part number		
TB1		068103	Terminal Block, 4Pos 1.5mm Com Clamp	■				/1.15
TB2		068103	Terminal Block, 4Pos 1.5mm Com Clamp	■		068105		/1.15

**Wood-Mizer®**

Project Description: HR130EC15-1

Revision: A6.02 Pg Desc: Terminal line-up diagram

Mounting Location: +Docs Type: Terminal line-up diagram

Prev. pg: D2 Page: D3 Next pg: D4 Total Pgs: 22

# Terminal line-up diagram

Wood-Mizer\_Terminal\_Lineup\_Diagram

Terminal strip +OP-TS4								
Terminal				Jumper		End Plate	Remark	Terminal X-Ref
Designation	Level	P/N	Description	Diagram	Part number	Part number		
TB1		068104	Terminal Block, 4Pos 1.5mm GND Clamp	•		068105		+MAIN/1.04
TB2		068103	Terminal Block, 4Pos 1.5mm Com Clamp	●	068113		Jumper is Trimmed Down To 2 Position Jumper Between TB2-3	+MAIN/3.02
TB3		068103	Terminal Block, 4Pos 1.5mm Com Clamp	●		068105		/7.17
TB4		068103	Terminal Block, 4Pos 1.5mm Com Clamp	•		068105		+MAIN/2.16
TB5		068103	Terminal Block, 4Pos 1.5mm Com Clamp	•		068105		+MAIN/4.07

**Wood-Mizer®**

Project Description: HR130EC15-1

Revision: A6.02 Pg Desc: Terminal line-up diagram

Mounting Location: +Docs Type: Terminal line-up diagram

Prev. pg: D3 Page: D4 Next pg: E1 Total Pgs: 22

# Cable overview

Wood-Mizer\_Cable\_Overview

Cable Designation	Cable Part Number	Cable Description	Cable X-Ref
CBL1	053743	Cable Assy, HR130 Up/Down Motor	+MAIN/1.115
CBL2	073703	Cable Assy, HR130 Feed Motor Connector	+MAIN/2.204
CBL3	069839	Cable Assy, HR130 Encoder	+OP/6.601
CBL4	078394	Cable, Modbus XBT RJ45 2.5m	+OP/5.506
HRN1	053742	Harness Assy, HR130EC15-1 Blade Motor	+MAIN/1.105
HRN2	053745	Harness Assy, HR130 Operator	+MAIN/1.104
HRN3	N/A	Part of Control Assembly	+MAIN/1.110

**Wood-Mizer®**

Project Description: HR130EC15-1

Revision:	A6.02	Pg Desc:	Cable overview
Mounting Location:	+Docs	Type:	Cable overview
Prev. pg:	D4	Page:	E1
Next pg:	F1	Total Pgs:	22



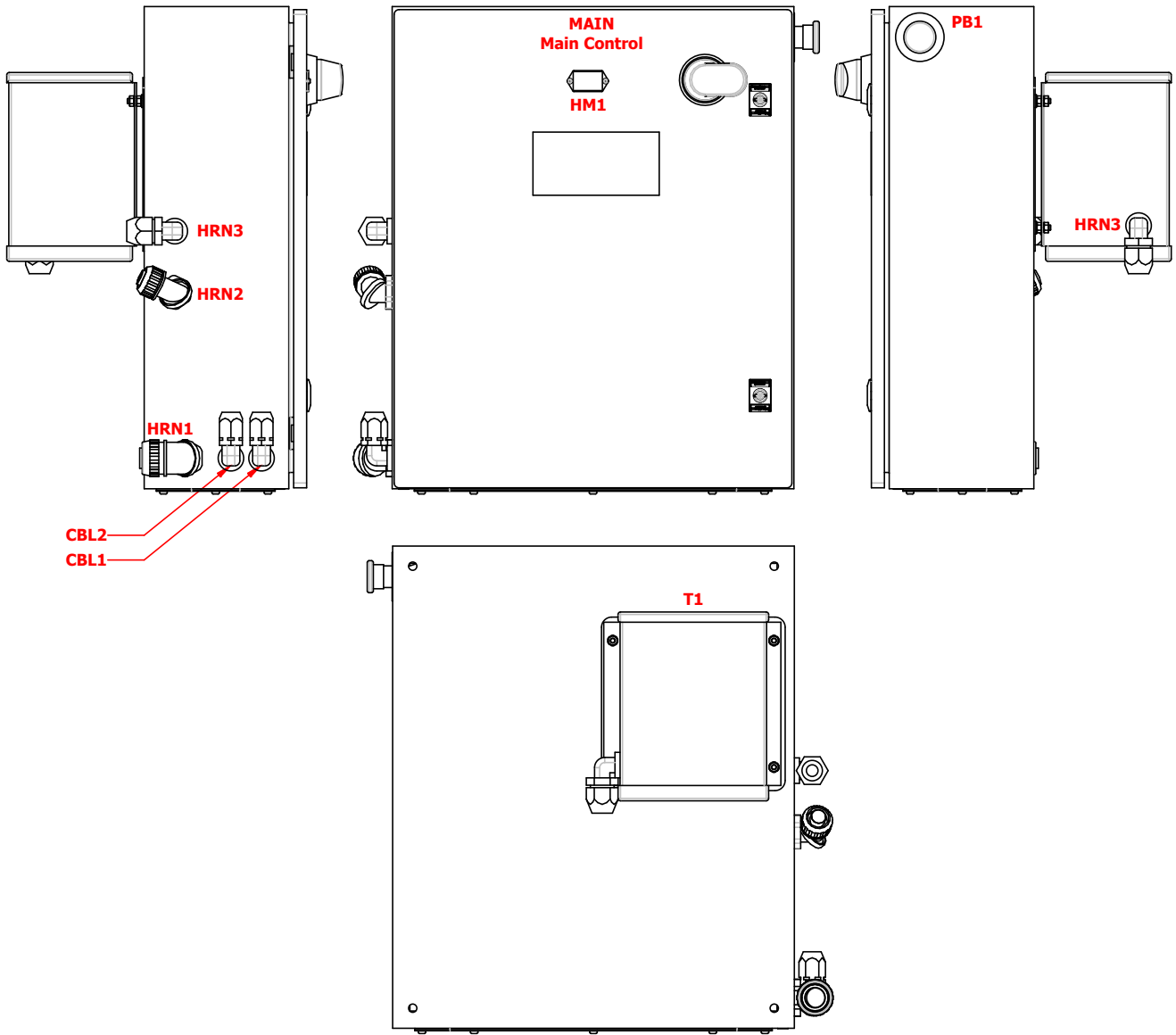

# Wood-Mizer®

Project Description: HR130EC15-1

Revision:	A6.02	Pg Desc:	Main Control Layout
Mounting Location:	+Docs	Type:	Panel layout
Prev. pg:	E1	Page:	F1
		Next pg:	F2
		Total Pgs:	22

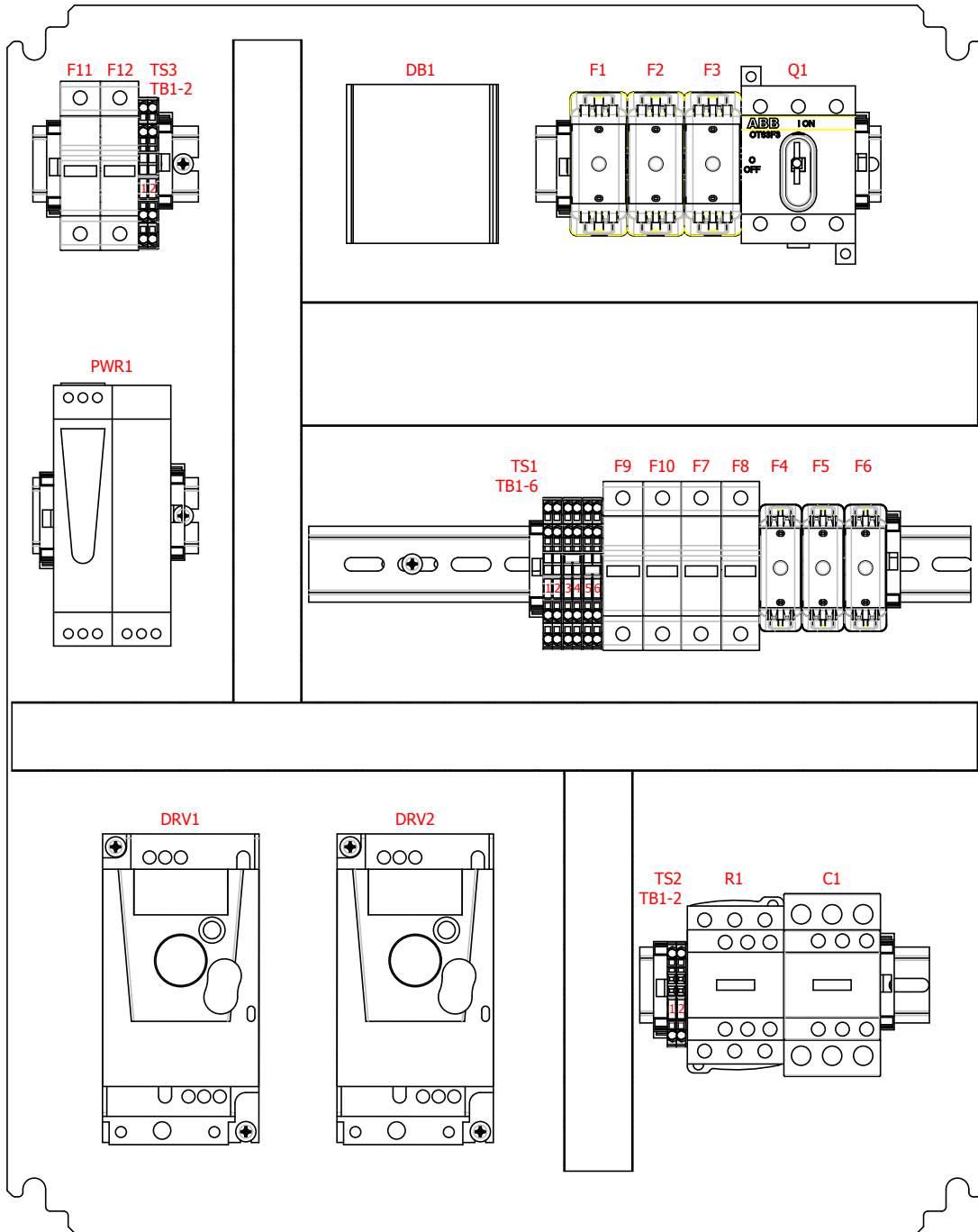

# Wood-Mizer®

Project Description: HR130EC15-1

Revision:	A6.02	Pg Desc:	Main Control Insert Layout
Mounting Location:	+Docs	Type:	Panel layout
Prev. pg:	F1	Page:	F2
Next pg:	F3	Total Pgs:	22

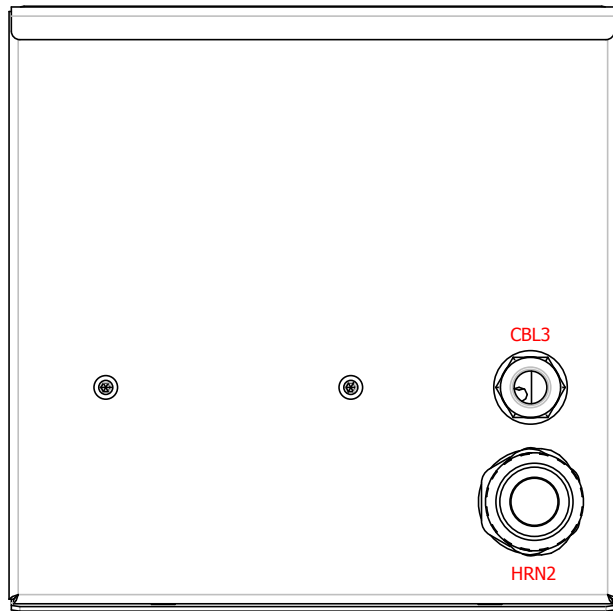
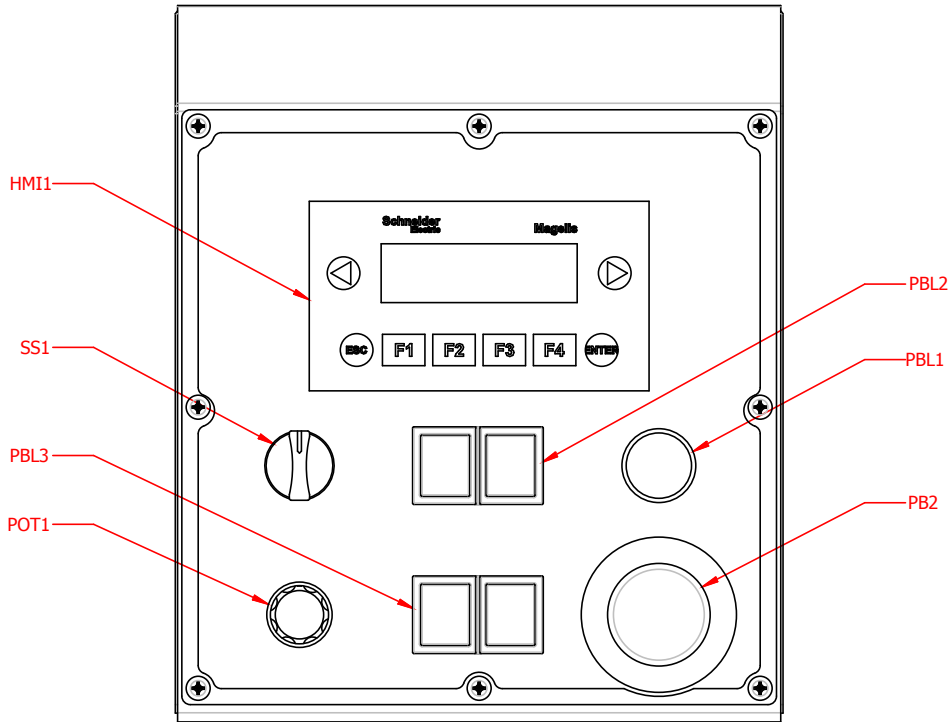

# Wood-Mizer®

Project Description: HR130EC15-1

Revision:	A6.02	Pg Desc:	Operator Layout
Mounting Location:	+Docs	Type:	Panel layout
Prev. pg:	F2	Page:	F3
		Next pg:	F4
		Total Pgs:	22

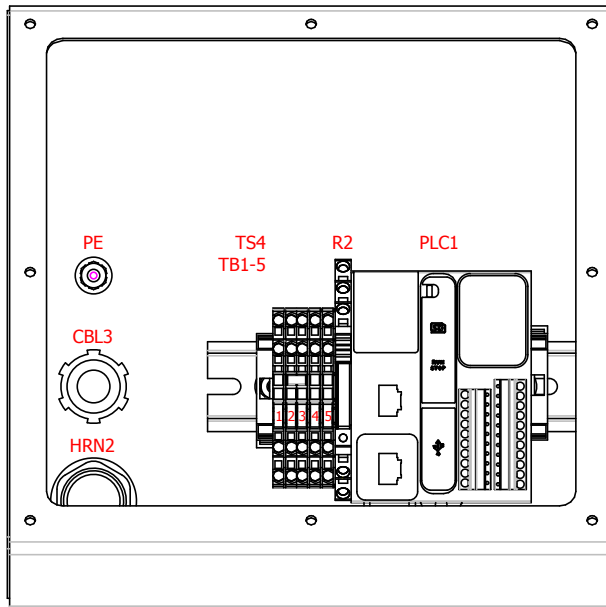
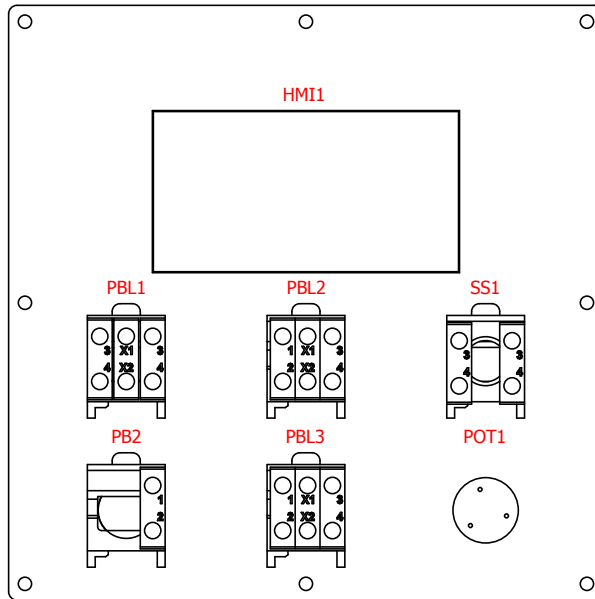

**Wood-Mizer®**

Project Description: HR130EC15-1

Revision: A6.02 Pg Desc: Operator Layout Internal

Mounting Location: +Docs Type: Panel layout

Prev. pg: F3 Page: F4 Next pg: F5 Total Pgs: 22

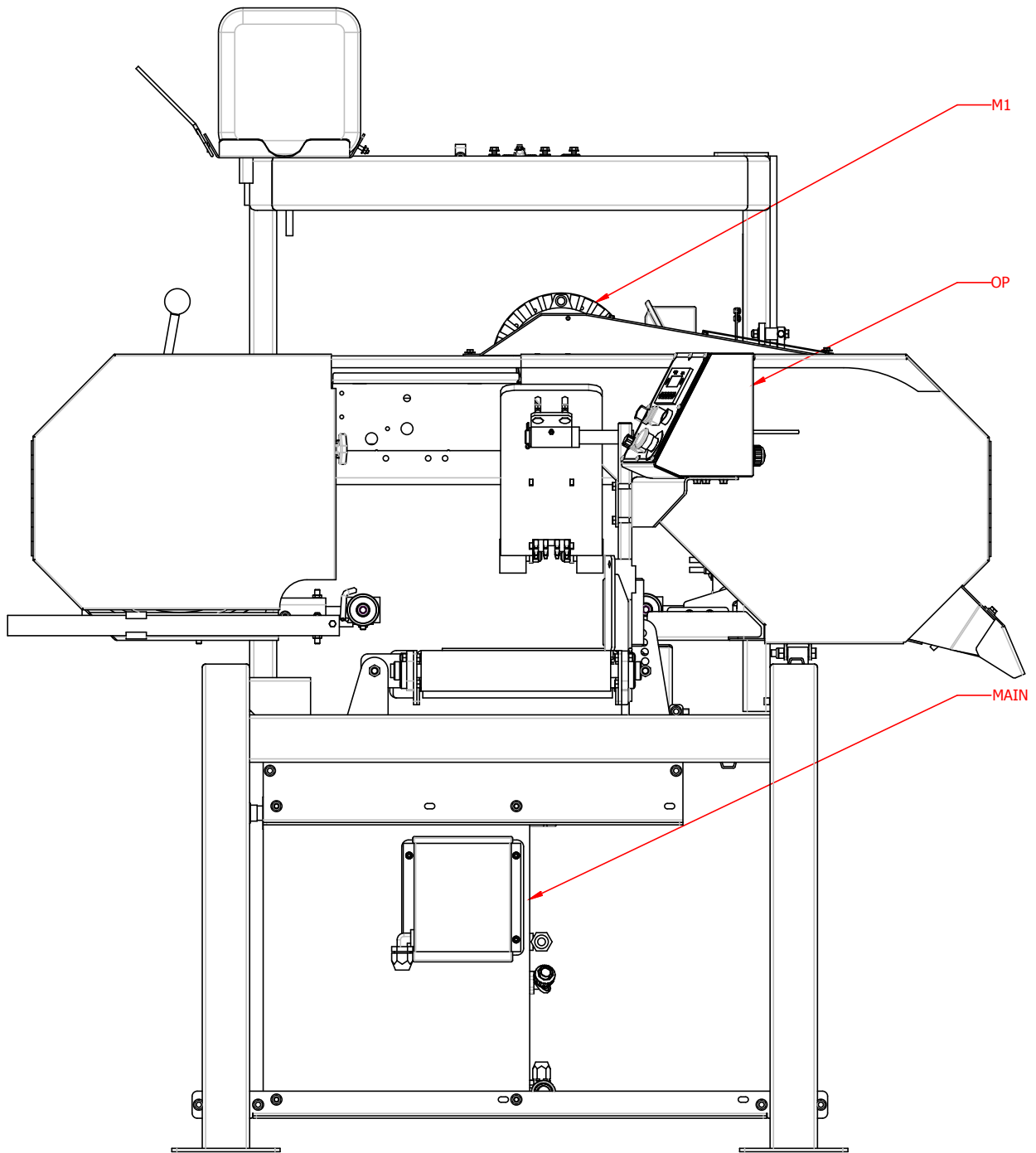

# Wood-Mizer®

Project Description: HR130EC15-1

Revision:	A6.02	Pg Desc:	Machine Front
Mounting Location:	+Docs	Type:	Panel layout
Prev. pg:	F4	Page:	F5
		Next pg:	F6
		Total Pgs:	22

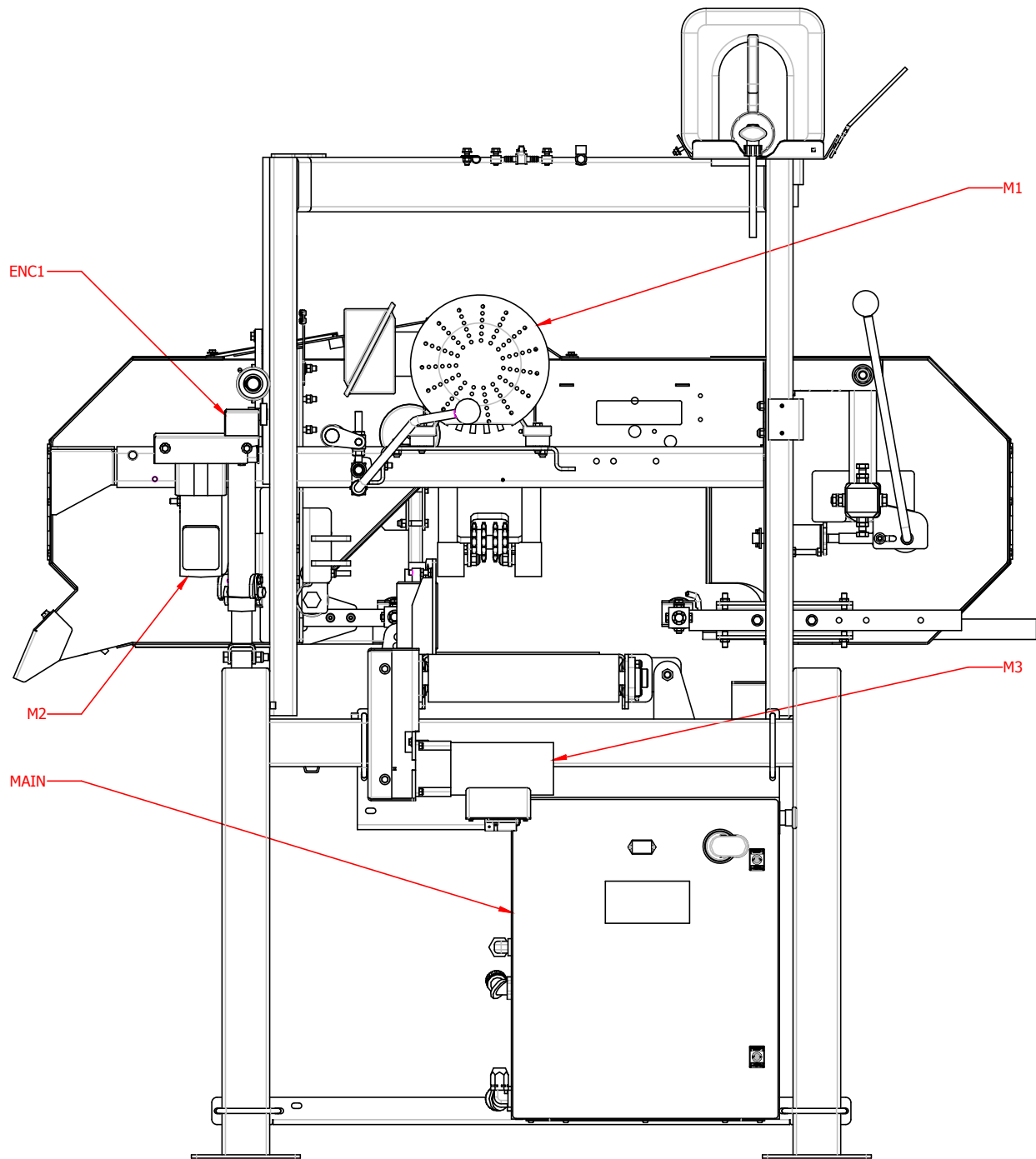

# Wood-Mizer®

Project Description: HR130EC15-1

Revision:	A6.02	Pg Desc:	Machine Layout Back
Mounting Location:	+Docs	Type:	Panel layout
Prev. pg:	F5	Page:	F6
		Next pg:	Total Pgs: 22

## **APPENDIX C ELECTRICAL INFORMATION**

**HR130EB15-1**

**Rev. A6.02-A6.04**

# Table of contents

WM\_TableOfContents

Page	Page type	Page description	Date	Edited by
/A1	Table of contents	Table of contents	12/30/2016	JRF
/B1	Overview	Revision History	12/29/2016	JRF
+MAIN/1	Schematic multi-line	Power Pg 1	12/30/2016	JRF
+MAIN/2	Schematic multi-line	Power Pg 2	12/30/2016	JRF
+MAIN/3	Schematic multi-line	Control Pg 1	12/29/2016	JRF
+MAIN/4	Schematic multi-line	Control Pg 2	12/29/2016	JRF
+OP/5	Schematic multi-line	PLC Pg 1	12/30/2016	JRF
+OP/6	Schematic multi-line	PLC Pg 2	12/30/2016	JRF
+OP/7	Schematic multi-line	PLC Pg 3	12/29/2016	JRF
+Docs/C1	Parts list	Parts list	12/30/2016	JRF
+Docs/D1	Terminal line-up diagram	Terminal line-up diagram	12/29/2016	JRF
+Docs/D2	Terminal line-up diagram	Terminal line-up diagram	12/29/2016	JRF
+Docs/D3	Terminal line-up diagram	Terminal line-up diagram	12/29/2016	JRF
+Docs/E1	Cable overview	Cable overview	12/30/2016	JRF
+Docs/F1	Panel layout	Main Control Layout	12/30/2016	JRF
+Docs/F2	Panel layout	Main Control Insert Layout	12/30/2016	JRF
+Docs/F3	Panel layout	Operator Layout	12/30/2016	JRF
+Docs/F4	Panel layout	Operator Layout Internal	12/30/2016	JRF
+Docs/F5	Panel layout	Machine Layout Front	12/30/2016	JRF
+Docs/F6	Panel layout	Machine Layout Back	12/30/2016	JRF

HR0057

<b>Wood-Mizer<sup>®</sup></b>			
Project Description: HR130EB15-1			
Revision:	A6.02	Pg Desc: Table of contents	
Mounting Location:	+	Type: Table of contents	
Prev. pg:	Page: A1	Next pg:	B1 Total Pgs: 20



# Revision History

Date	Revision	Revision Record	Drawn By	Checked By
9/1/10	A1.01	Changed Power Supply Fuses For CSA	JRF	SDC
3/10/11	A2.00	Added Top Level Machines w/Setworks	JRF	SDC
11/21/13	A3.00	Setworks Software V2.0	JRF	SDC
5/28/14	A4.00	Changed Scheider Electric Terminal Blocks To Wago	JRF	SDC
9/3/15	A4.03	Added Connector To Feed Motor	JRF	JEC
9/28/15	A5.00	Change To High Efficiency Blade Motor	JRF	SDC
6/24/16	A6.00	Setworks Software V3.0	JRF	SDC
10/31/16	A6.01	Added Terminal Block For PLC Output V+ Connection	JRF	SDC

**Wood-Mizer®**

Project Description: HR130EB15-1

Revision:	A6.02	Pg Desc:	Revision History
Mounting Location:	+	Type:	Overview
Prev. pg:	A1	Page:	B1
Next pg:	+MAIN/1	Total Pgs:	20

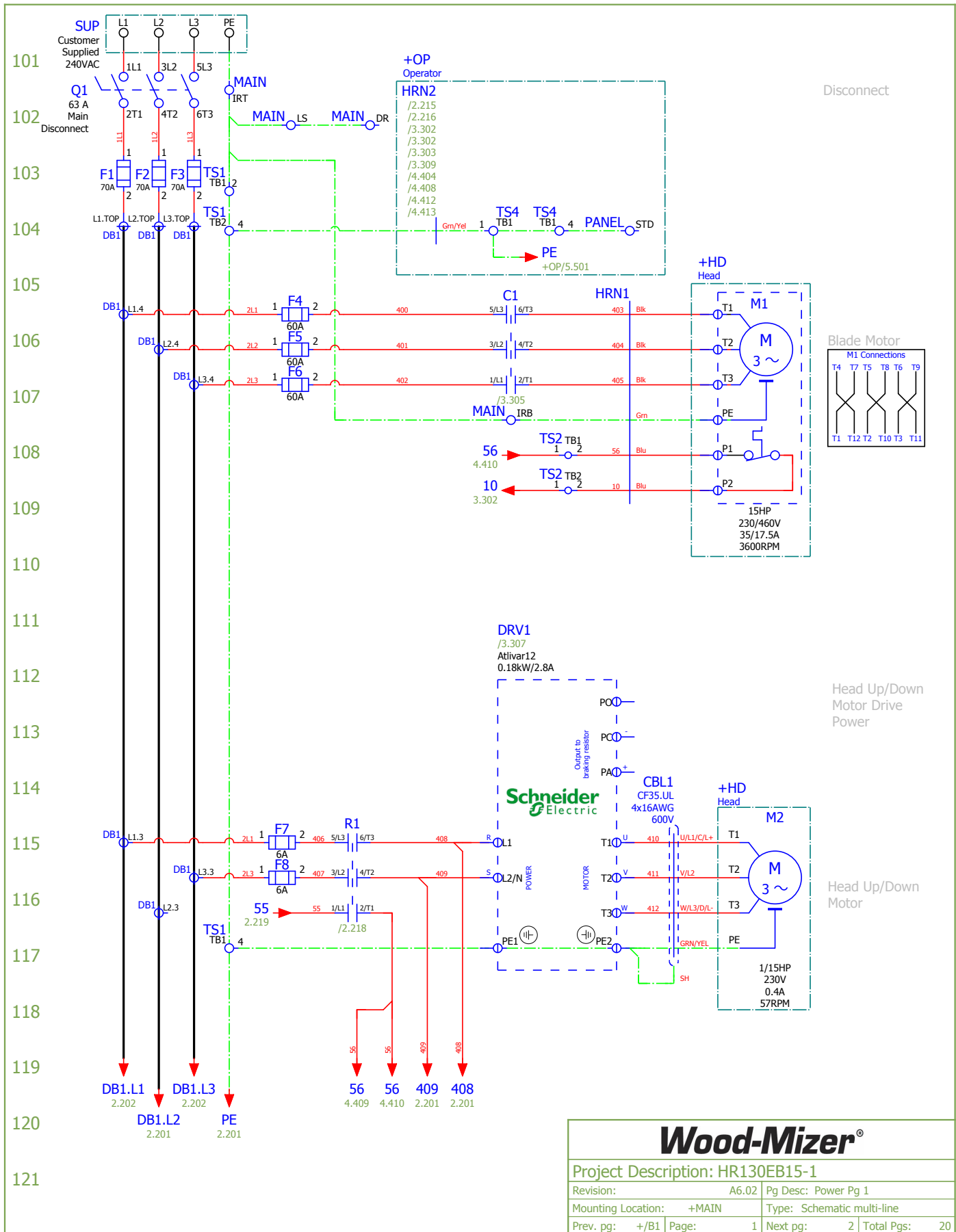

# Wood-Mizer®

Project Description: HR130EB15-1			
Revision:	A6.02	Pg Desc: Power Pg 1	
Mounting Location:	+MAIN	Type: Schematic multi-line	
Prev. pg:	+/B1	Page:	1
Next pg:	2	Total Pgs:	20

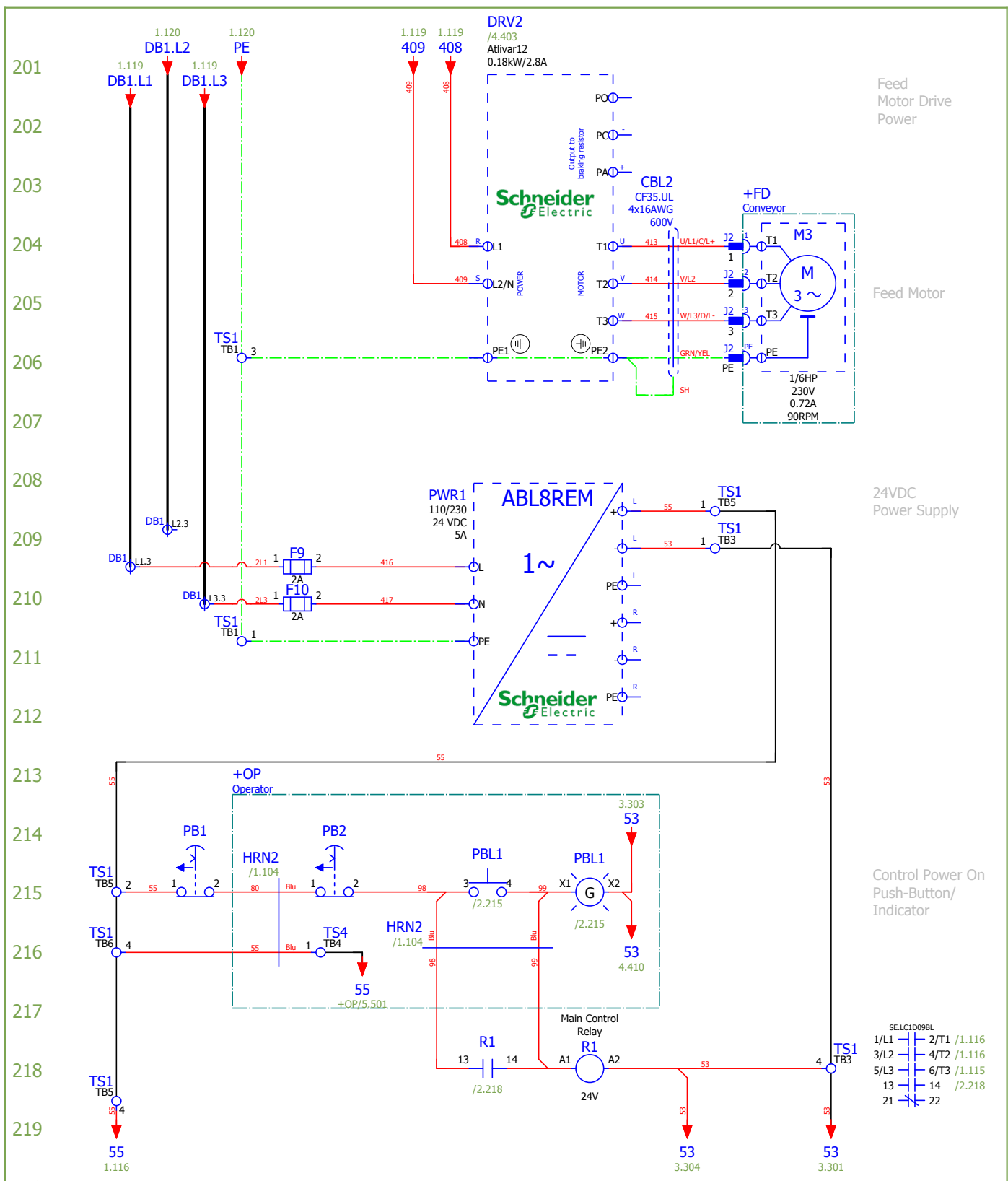

# Wood-Mizer®

Project Description: HR130EB15-1		
Revision:	A6.02	Pg Desc: Power Pg 2
Mounting Location:	+MAIN	Type: Schematic multi-line
Prev. pg.:	1	Page: 2
		Next pg.: 3
		Total Pgs: 20

301  
302  
303  
304  
305  
306  
307  
308  
309  
310  
311  
312  
313  
314  
315  
316  
317  
318  
319  
320  
321

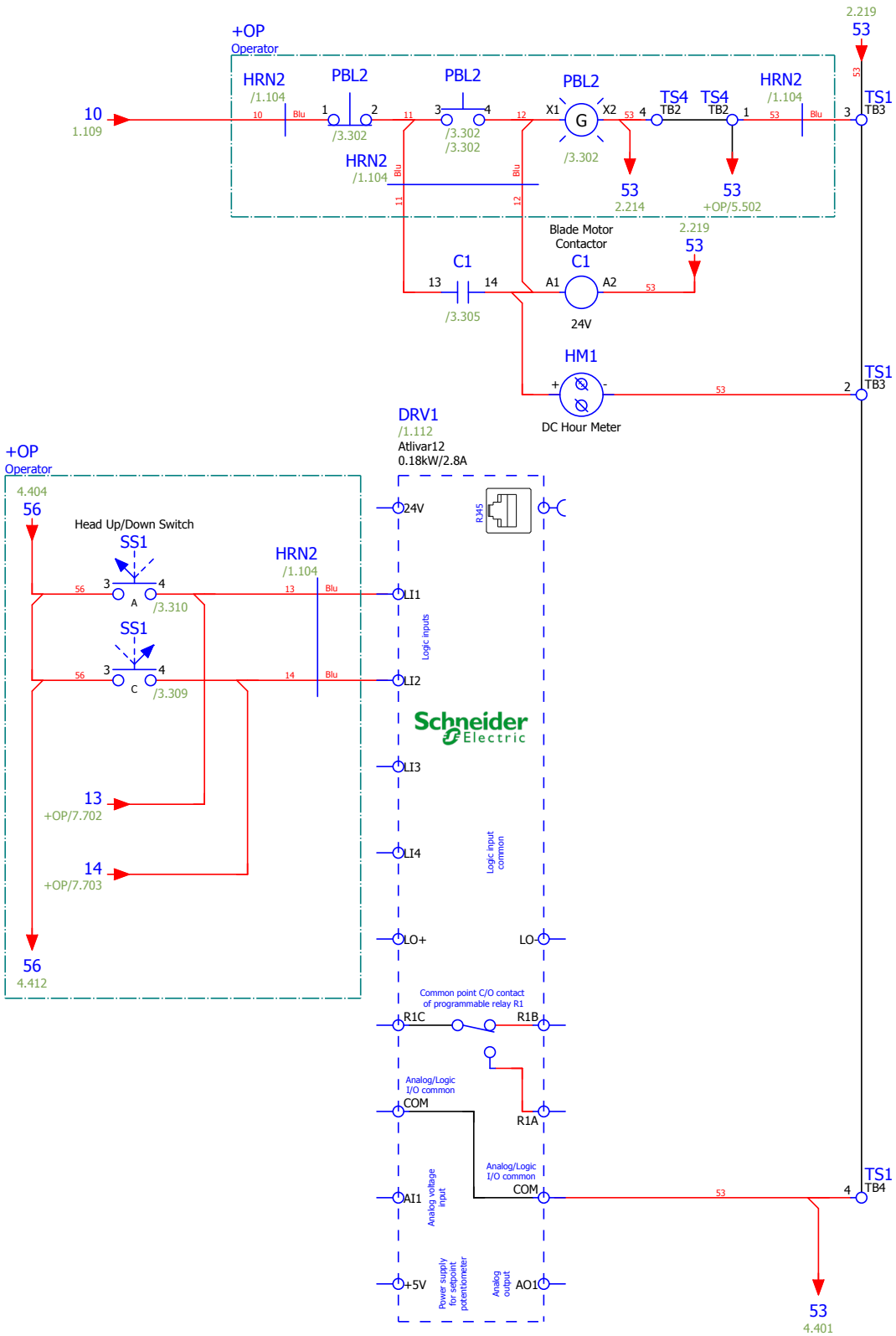

Blade Motor  
Start/Stop  
Push-Button/  
Indicator

SE.LCID25BD  
1/L1 2/T1 /1.107  
3/L2 4/T2 /1.106  
5/L3 6/T3 /1.106  
13 14 /3.305  
21 22

Blade Motor  
Hour Meter

Head Up/Down  
Motor Drive  
Control

Head Up

Head Down



**Wood-Mizer®**

Project Description: HR130EB15-1			
Revision:	A6.02	Pg Desc: Control Pg 1	
Mounting Location:	+MAIN	Type: Schematic multi-line	
Prev. pg:	2	Page:	3
Next pg:	4	Total Pgs:	20

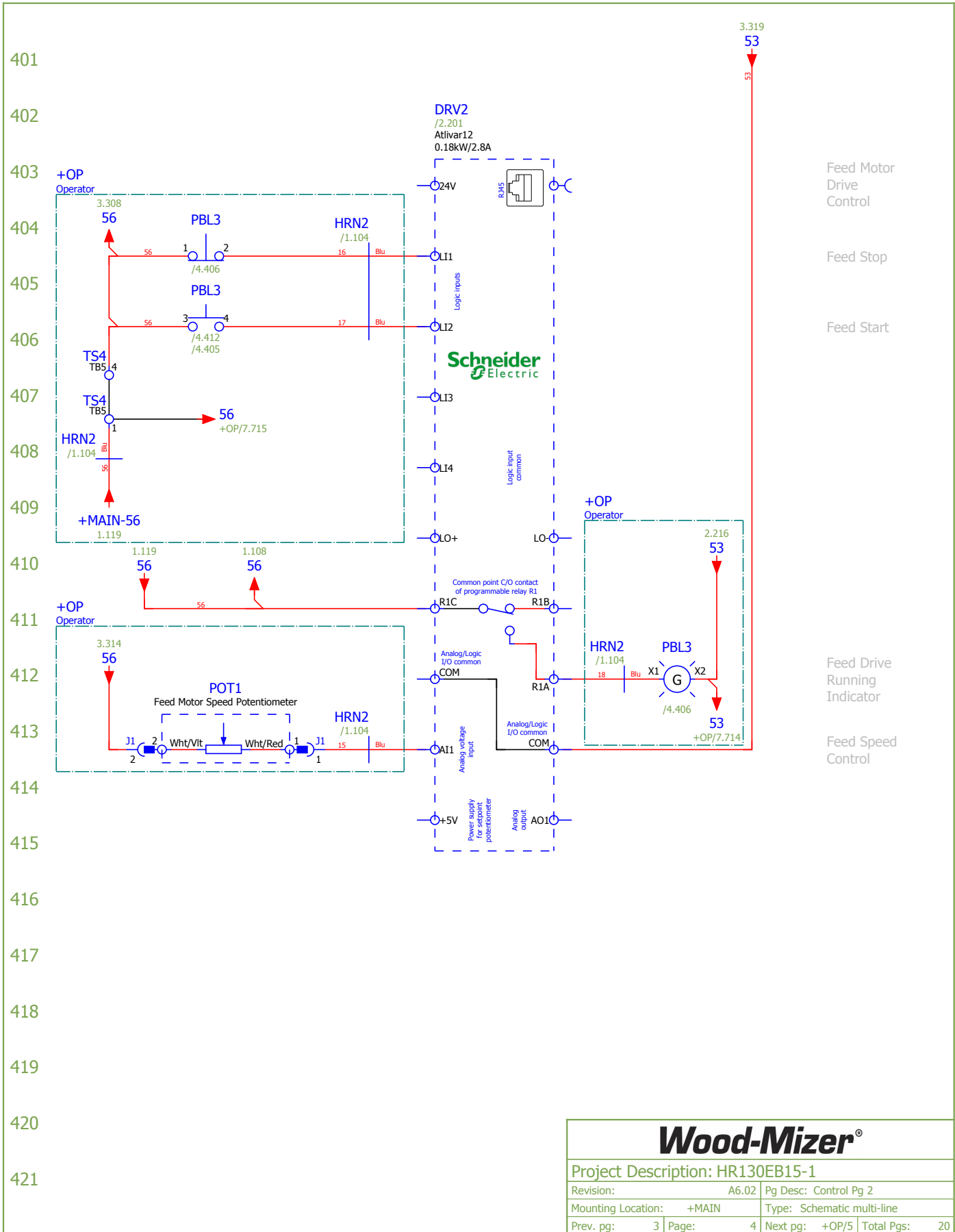

# Wood-Mizer®

Project Description: HR130EB15-1			
Revision:	A6.02	Pg Desc: Control Pg 2	
Mounting Location:	+MAIN	Type: Schematic multi-line	
Prev. pg:	3	Page:	4
		Next pg:	+OP/5
		Total Pgs:	20

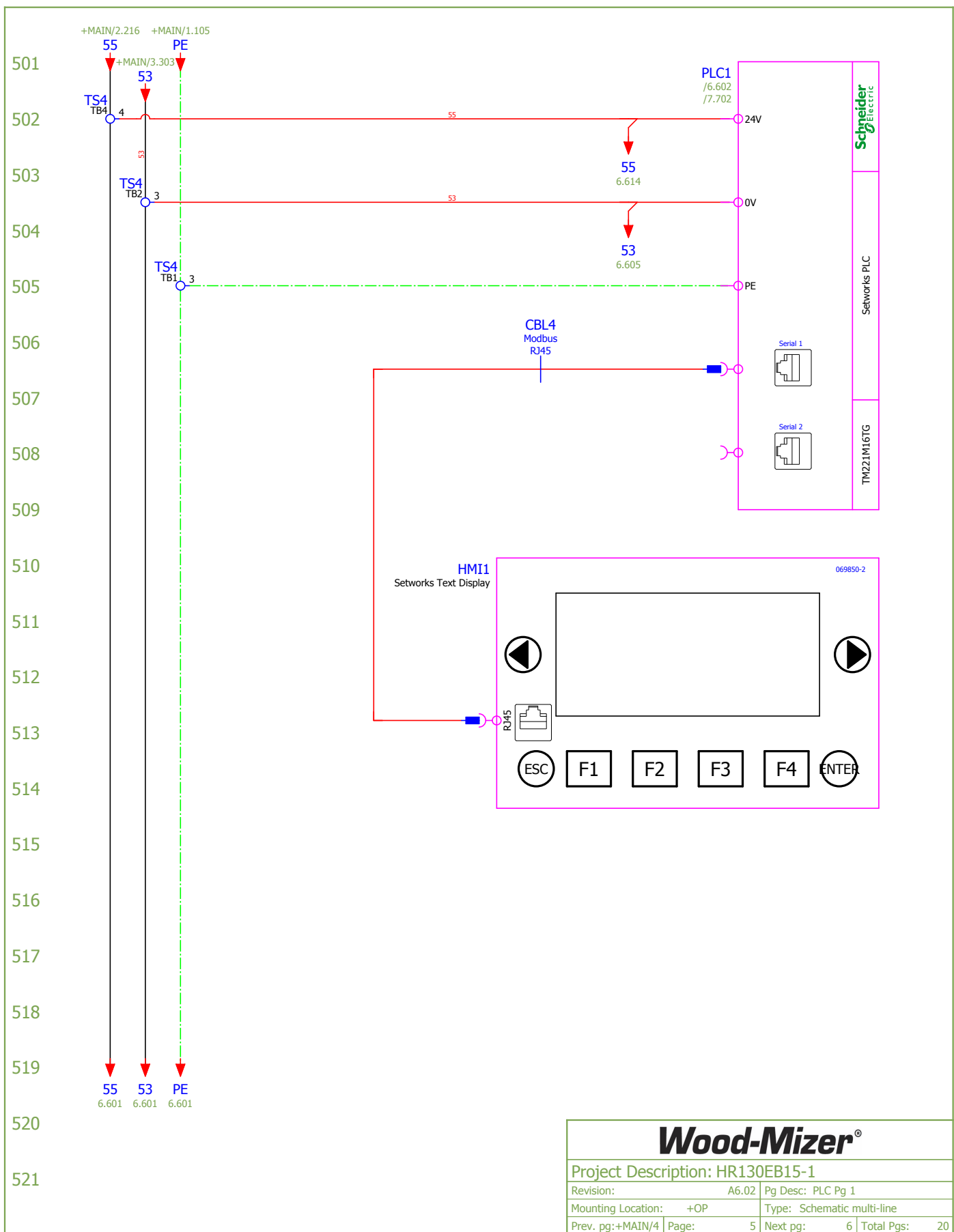

**Wood-Mizer®**

Project Description: HR130EB15-1			
Revision:	A6.02	Pg Desc:	PLC Pg 1
Mounting Location:	+OP	Type:	Schematic multi-line
Prev. pg: +MAIN/4	Page:	5	Next pg: 6 Total Pgs: 20

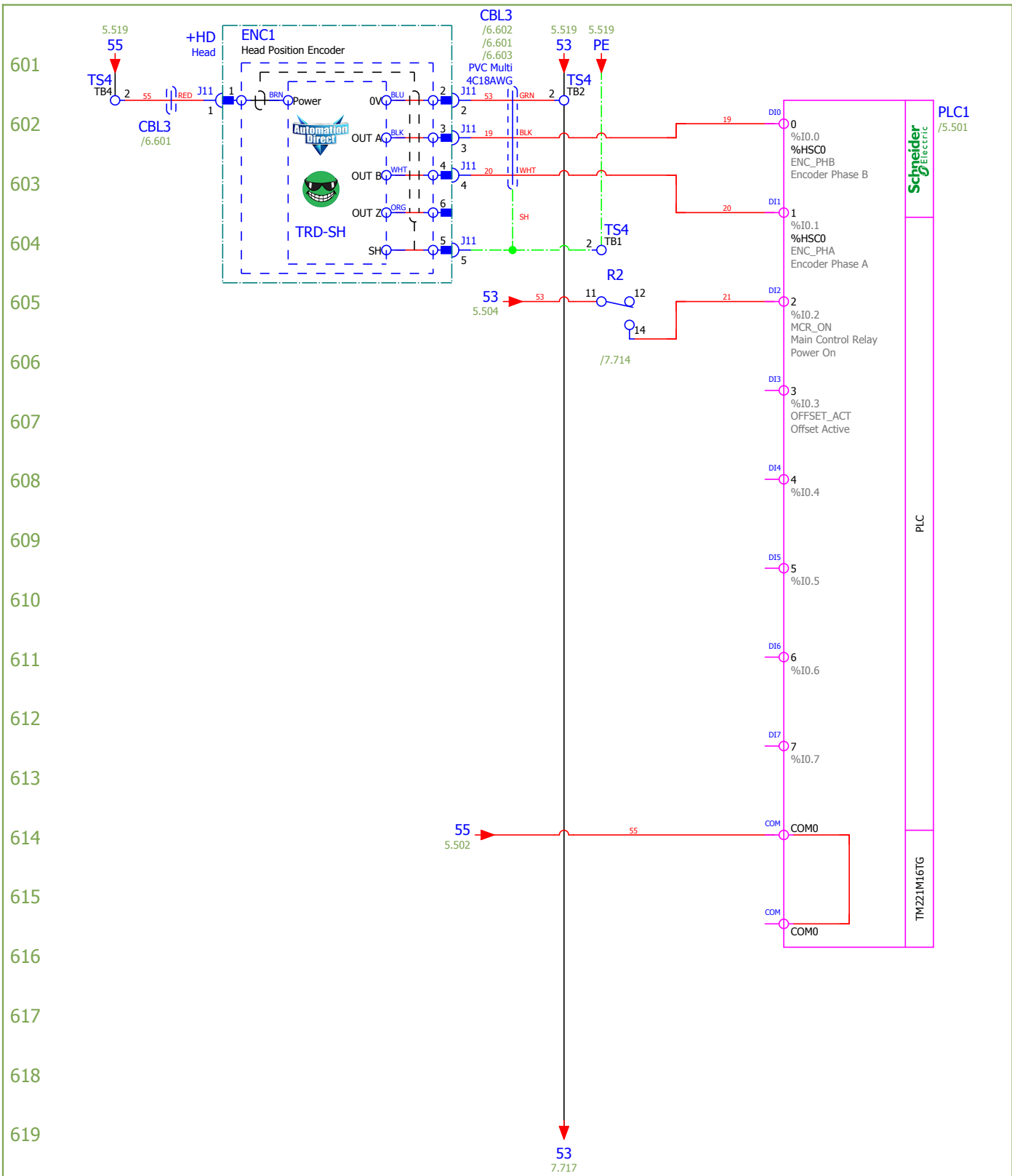

601  
602  
603  
604  
605  
606  
607  
608  
609  
610  
611  
612  
613  
614  
615  
616  
617  
618  
619  
620  
621

701  
702  
703  
704  
705  
706  
707  
708  
709  
710  
711  
712  
713  
714  
715  
716  
717  
718  
719  
720  
721

PLC1  
/5.501

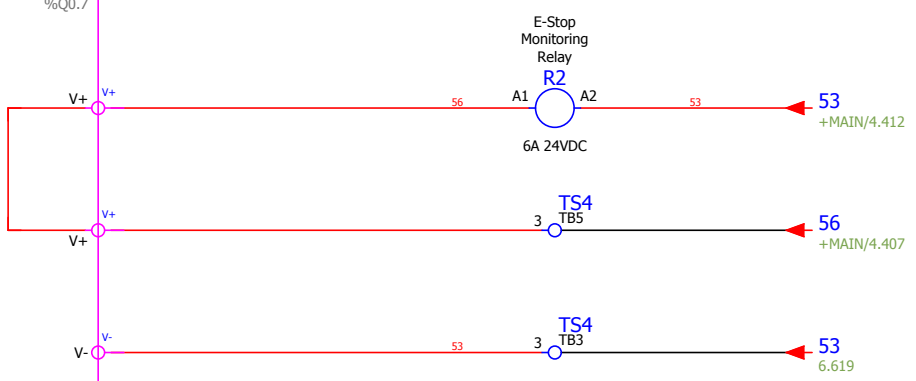
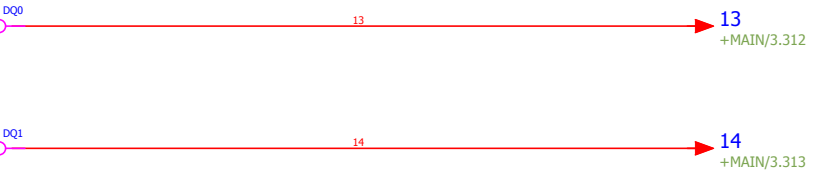
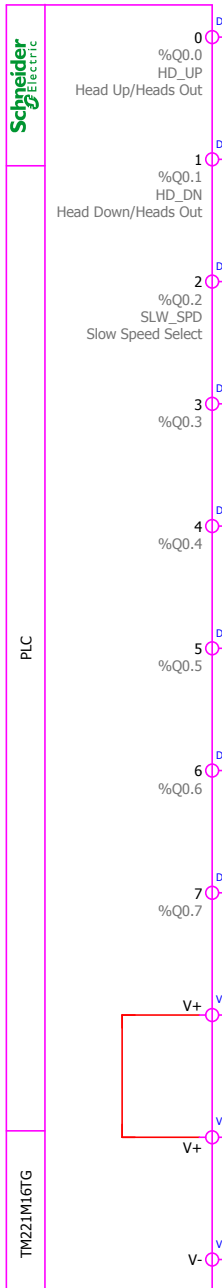

FR\_38.61.7.024.0050  
14  
12 11 /6.605

<b>Wood-Mizer®</b>			
Project Description: HR130EB15-1			
Revision:	A6.02	Pg Desc:	PLC Pg 3
Mounting Location:	+OP	Type:	Schematic multi-line
Prev. pg:	6	Page:	7
Next pg:+	Docs/C1	Total Pgs:	20



# Device Tag/Parts List

WM\_PARTS\_LIST-Manual

Device tag	Function	Wood-Mizer Part Number	Wood-Mizer Description	Qty.	X-Ref
C1	Blade Motor Contactor	051322	Contact, 25A 3P 24VDC Coil	1	+MAIN/3.305
DB1	Distribution Block	069701	Distribution Block, 3P 1 to 4	1	+MAIN/1.104
DRV1	Head Up/Down Motor Drive Power	069799	AC Drive Assy, HR130 Up/Down w/Software	1	+MAIN/1.112
DRV2	Feed Motor Drive Power	069800	Drive Assy, HR130 Feed w/Software	1	+MAIN/2.201
ENC1	Head Position Encoder	069840	Encoder Assy, HR130 Networks	1	+OP/6.601
F1	Main L1 Fuse	053586	Fuseholder, 100A Cube	1	+MAIN/1.103
F1	=	069707	Fuse, 70A Class J Cube	1	+MAIN/1.103
F2	Main L2 Fuse	053586	Fuseholder, 100A Cube	1	+MAIN/1.103
F2	=	069707	Fuse, 70A Class J Cube	1	+MAIN/1.103
F3	Main L3 Fuse	053586	Fuseholder, 100A Cube	1	+MAIN/1.103
F3	=	069707	Fuse, 70A Class J Cube	1	+MAIN/1.103
F4	Blade Motor L1 Fuse	053717	Fuseholder, 60A Cube	1	+MAIN/1.106
F4	=	069708	Fuse, 60A Class J Cube	1	+MAIN/1.106
F5	Blade Motor L2 Fuse	053717	Fuseholder, 60A Cube	1	+MAIN/1.106
F5	=	069708	Fuse, 60A Class J Cube	1	+MAIN/1.106
F6	Blade Motor L3 Fuse	053717	Fuseholder, 60A Cube	1	+MAIN/1.107
F6	=	069708	Fuse, 60A Class J Cube	1	+MAIN/1.107
F7	Up/Down Motor Drive L1 Fuse	052512	Fuse Holder, 2P Class CC Screw Clamp	1	+MAIN/1.115
F7	=	052456	Fuse, 6A 600V Calss CC Delay	1	+MAIN/1.115
F8	Up/Down Motor Drive L2 Fuse	052456	Fuse, 6A 600V Calss CC Delay	1	+MAIN/1.116
F9	Power Supply L1 Fuse	052512	Fuse Holder, 2P Class CC Screw Clamp	1	+MAIN/2.209
F9	=	E22716	Fuse, 2A 600V Class CC	1	+MAIN/2.209
F10	Power Supply N Fuse	E22716	Fuse, 2A 600V Class CC	1	+MAIN/2.210
HM1	Blade Motor Hour Meter	015401	Digital Meter, Hour Rect Mount w/Gasket	1	+MAIN/3.306
HMI1	Networks Text Display	069850-2	HMI Assy, PLC Networks	1	+OP/5.510
M1	Blade Motor	074780	Motor, 15HP 3520RPM Leeson Wattsaver	1	+MAIN/1.105
M2	Feed Motor	025696	Motor, 1/15HP 57RPM 230V 3PH 30:1 Gear	1	+MAIN/1.115
M3	=	073702	Motor Assy, HR130 Feed Conveyor	1	+MAIN/2.204
PB1	Main E-Stop Push-Button	025161	Switch Body, 1NC 22mm ZB4	1	+MAIN/2.215
PB1	=	024945	Switch, PB E-Stop Maintnd Red 22mm ZB4	1	+MAIN/2.215
PB1	=	050992	Legend, E-Stop, Round Yellow	1	+MAIN/2.215
PB2	Operator E-Stop Push-Button	025161	Switch Body, 1NC 22mm ZB4	1	+MAIN/2.215
PB2	=	024945	Switch, PB E-Stop Maintnd Red 22mm ZB4	1	+MAIN/2.215
PB2	=	050992	Legend, E-Stop, Round Yellow	1	+MAIN/2.215
PBL1	Control Power On Push-Button	024974-3	Switch, PB Grn 22mm 1NO/1NC LED 24V XB4	1	+MAIN/2.215
PBL2	Blade Motor Start/Stop Push-Button	025236-31	Switch Body, 22mm Grn LED 1 NO 24V ZB4	1	+MAIN/3.302
PBL2	=	051746	Switch Operator, 2 Button w/Pilot Red/Gr	1	+MAIN/3.302
PBL2	=	050540	Contact, NC ZBE102	1	+MAIN/3.302
PBL2	=	052501	Boot, Clear Sealing ZB Sw	1	+MAIN/3.302
PBL3	Feed Motor Start/Stop Push-Button	025236-31	Switch Body, 22mm Grn LED 1 NO 24V ZB4	1	+MAIN/4.406
PBL3	=	051746	Switch Operator, 2 Button w/Pilot Red/Gr	1	+MAIN/4.406
PBL3	=	050540	Contact, NC ZBE102	1	+MAIN/4.406
PBL3	=	052501	Boot, Clear Sealing ZB Sw	1	+MAIN/4.406
PLC1	Networks PLC	069849-3	PLC Ass, PLC Networks	1	+OP/5.501
POT1	Feed Motor Speed Potentiometer	025200	Pot Assy, 4-20mA 24V W/conn	1	+MAIN/4.413
POT1	=	033476	O-Ring, 7/32 IN #009	2	+MAIN/4.413
POT1	=	033478	Knob, 1/4 ID Fluted Round Plastic	1	+MAIN/4.413
PWR1	24VDC Power Supply	069703	Power Supply, 24VDC 5A 110/230	1	+MAIN/2.208
Q1	Main Disconnect	050881-1	Disconnect, 63A 600V 3P 6mm Shaft	1	+MAIN/1.102
Q1	=	050908-1	Shaft, 290mm Pistol Grip Disconnect	1	+MAIN/1.102
Q1	=	050907-1	Handle, Disconnect Red/Yel Pistol Grip	1	+MAIN/1.102
R1	Main Control Relay	024890	Contact, 9A 3P 24VDC Coil	1	+MAIN/2.218
R2	E-Stop Monitoring Relay	069883	Relay, 6A 24VDC w/ Cage Clamp Socket	1	+OP/7.714
SS1	Head Up/Down Switch	050545	Base, 2NO Contact	1	+MAIN/3.309
SS1	=	051744	Switch Operator, 3 Pos Sel Mom ZB4	1	+MAIN/3.309

## Wood-Mizer®

Project Description: HR130EB15-1

Revision:	A6.02	Pg Desc:	Parts list
Mounting Location:	+Docs	Type:	Parts list
Prev. pg:	+OP/7	Page:	C1
Next pg:	D1	Total Pgs:	20

# Terminal line-up diagram

Wood-Mizer\_Terminal\_Lineup\_Diagram

## Terminal strip +MAIN-TS1

Terminal				Jumper		End Plate	Remark	Terminal X-Ref
Designation	Level	P/N	Description	Diagram	Part number	Part number		
TB1		068104	Terminal Block, 4Pos 1.5mm GND Clamp	•				/1.03
TB2		068104	Terminal Block, 4Pos 1.5mm GND Clamp	•		068105		/1.04
TB3		068103	Terminal Block, 4Pos 1.5mm Com Clamp	●	068113		Jumper is Trimmed Down To 2 Position Jumper Between TB3-4	/2.09
TB4		068103	Terminal Block, 4Pos 1.5mm Com Clamp	●		068105		/3.18
TB5		068103	Terminal Block, 4Pos 1.5mm Com Clamp	●	068113		Jumper is Trimmed Down To 2 Position Jumper Between TB5-6	/2.09
TB6		068103	Terminal Block, 4Pos 1.5mm Com Clamp	●		068105		/2.16

**Wood-Mizer®**

Project Description: HR130EB15-1

Revision: A6.02 Pg Desc: Terminal line-up diagram

Mounting Location: +Docs Type: Terminal line-up diagram

Prev. pg: C1 Page: D1 Next pg: D2 Total Pgs: 20

# Terminal line-up diagram

Wood-Mizer\_Terminal\_Lineup\_Diagram

Terminal strip +MAIN-TS2								
Terminal				Jumper		End Plate	Remark	Terminal X-Ref
Designation	Level	P/N	Description	Diagram	Part number	Part number		
TB1		068100	Terminal Block, 2Pos 1.5mm Clamp	■				/1.08
TB2		068100	Terminal Block, 2Pos 1.5mm Clamp	■		068102		/1.09

**Wood-Mizer®**

Project Description: HR130EB15-1

Revision: A6.02 Pg Desc: Terminal line-up diagram

Mounting Location: +Docs Type: Terminal line-up diagram

Prev. pg: D1 Page: D2 Next pg: D3 Total Pgs: 20

# Terminal line-up diagram

Wood-Mizer\_Terminal\_Lineup\_Diagram

## Terminal strip +OP-TS4

Terminal				Jumper		End Plate	Remark	Terminal X-Ref
Designation	Level	P/N	Description	Diagram	Part number	Part number		
TB1		068104	Terminal Block, 4Pos 1.5mm GND Clamp	•		068105		+MAIN/1.04
TB2		068103	Terminal Block, 4Pos 1.5mm Com Clamp	●	068113		Jumper is Trimmed Down To 2 Position Jumper Between TB2-3	+MAIN/3.02
TB3		068103	Terminal Block, 4Pos 1.5mm Com Clamp	●		068105		/7.17
TB4		068103	Terminal Block, 4Pos 1.5mm Com Clamp	•		068105		+MAIN/2.16
TB5		068103	Terminal Block, 4Pos 1.5mm Com Clamp	•		068105		+MAIN/4.07

**Wood-Mizer®**

Project Description: HR130EB15-1

Revision: A6.02 Pg Desc: Terminal line-up diagram

Mounting Location: +Docs Type: Terminal line-up diagram

Prev. pg: D2 Page: D3 Next pg: E1 Total Pgs: 20

# Cable overview

Wood-Mizer\_Cable\_Overview

<b>Cable</b> Designation	<b>Cable</b> Part Number	<b>Cable</b> Description	<b>Cable</b> X-Ref
CBL1	053743	Cable Assy, HR130 Up/Down Motor	+MAIN/1.115
CBL2	073703	Cable Assy, HR130 Feed Motor Connector	+MAIN/2.204
CBL3	069839	Cable Assy, HR130 Encoder	+OP/6.601
CBL4	078394	Cable, Modbus XBT RJ45 2.5m	+OP/5.506
HRN1	053741	Harness Assy, HR130EB15-1 Blade Motor	+MAIN/1.105
HRN2	053745	Harness Assy, HR130 Operator	+MAIN/1.104

**Wood-Mizer®**

Project Description: HR130EB15-1

Revision: A6.02 Pg Desc: Cable overview

Mounting Location: +Docs Type: Cable overview

Prev. pg: D3 Page: E1 Next pg: F1 Total Pgs: 20

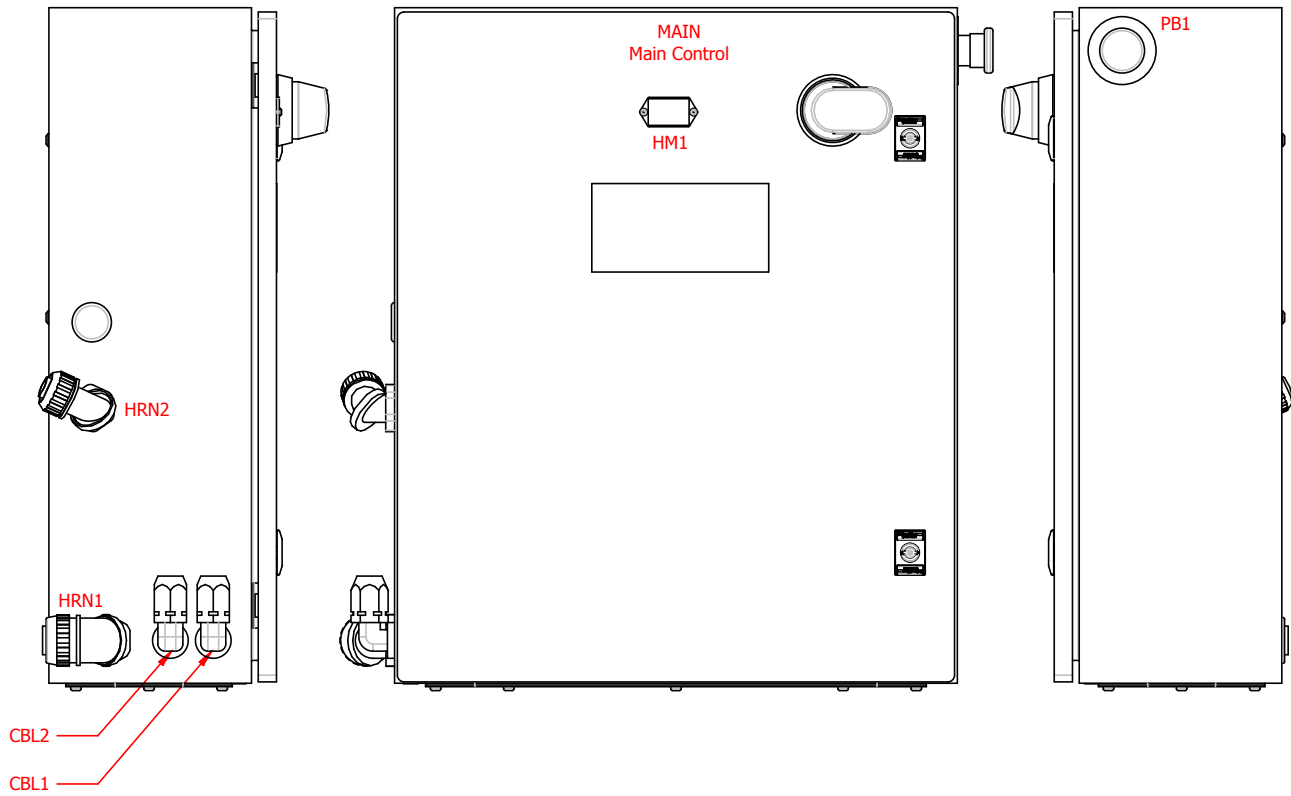

# Wood-Mizer®

Project Description: HR130EB15-1

Revision:	A6.02	Pg Desc:	Main Control Layout
Mounting Location:	+Docs	Type:	Panel layout
Prev. pg:	E1	Page:	F1
		Next pg:	F2
		Total Pgs:	20

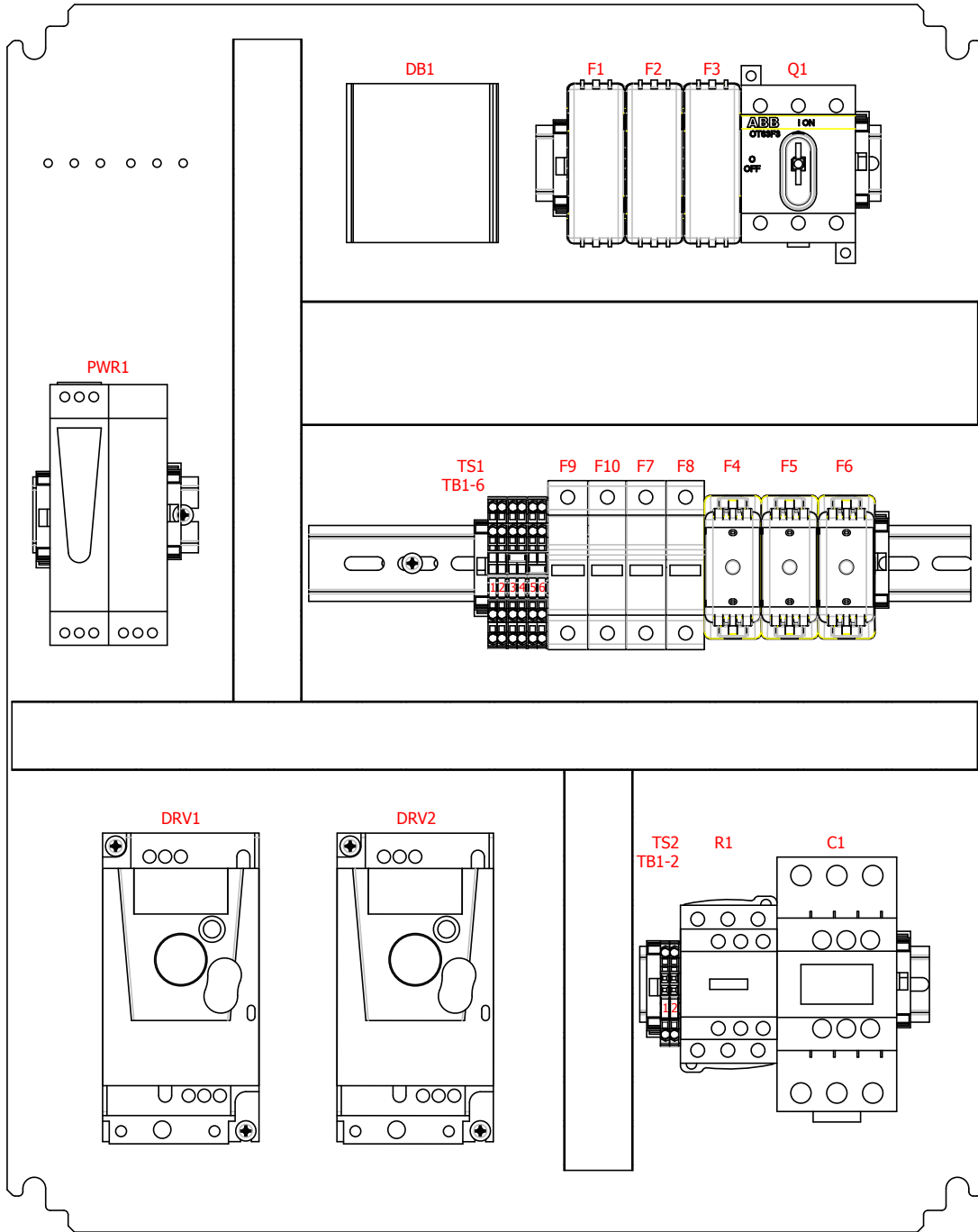

# Wood-Mizer®

Project Description: HR130EB15-1

Revision:	A6.02	Pg Desc:	Main Control Insert Layout
Mounting Location:	+Docs	Type:	Panel layout
Prev. pg:	F1	Page:	F2
		Next pg:	F3
		Total Pgs:	20

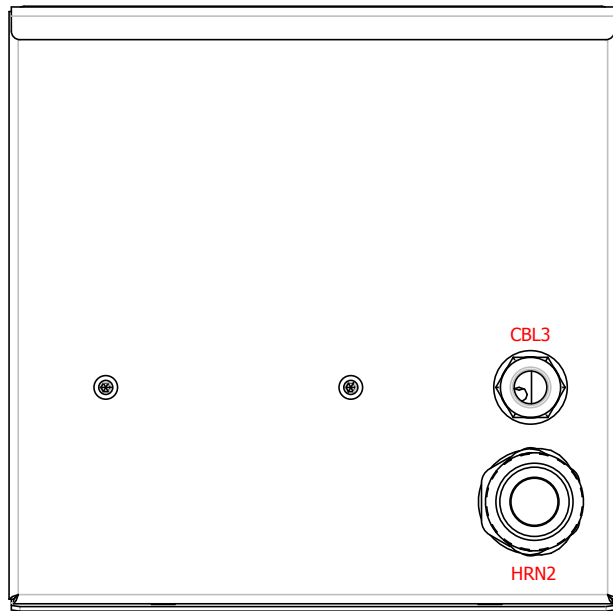
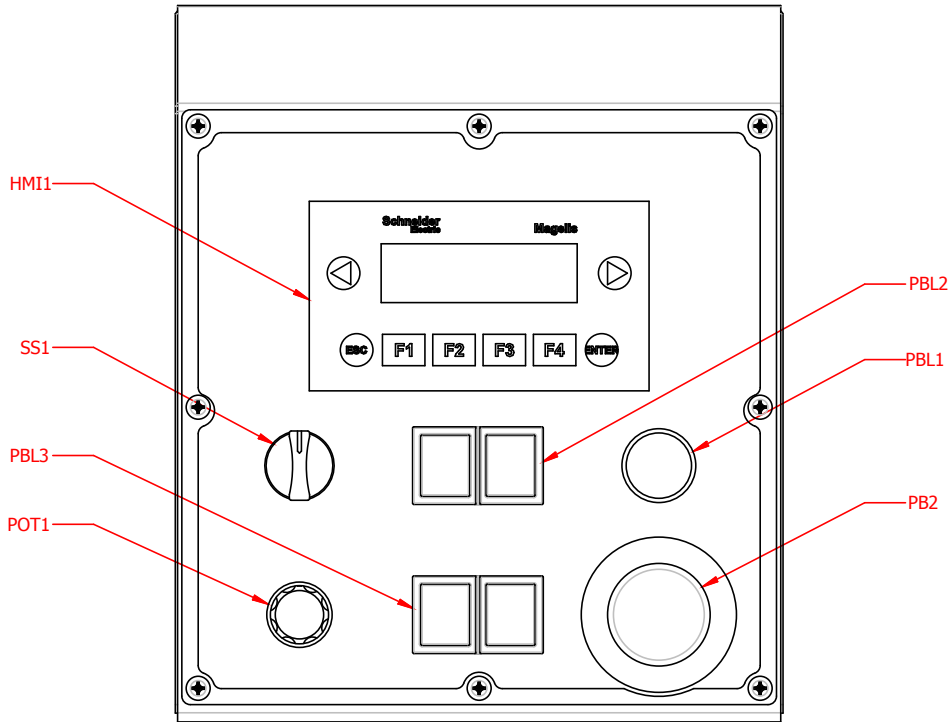

# Wood-Mizer®

Project Description: HR130EB15-1

Revision:	A6.02	Pg Desc:	Operator Layout
Mounting Location:	+Docs	Type:	Panel layout
Prev. pg:	F2	Page:	F3
		Next pg:	F4
		Total Pgs:	20



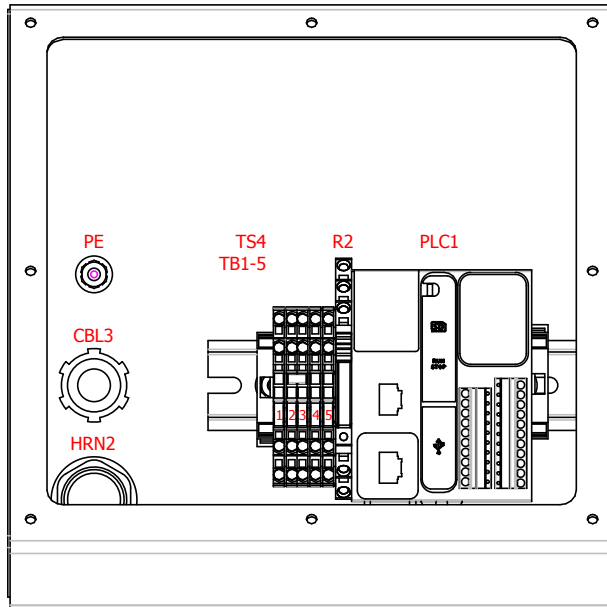
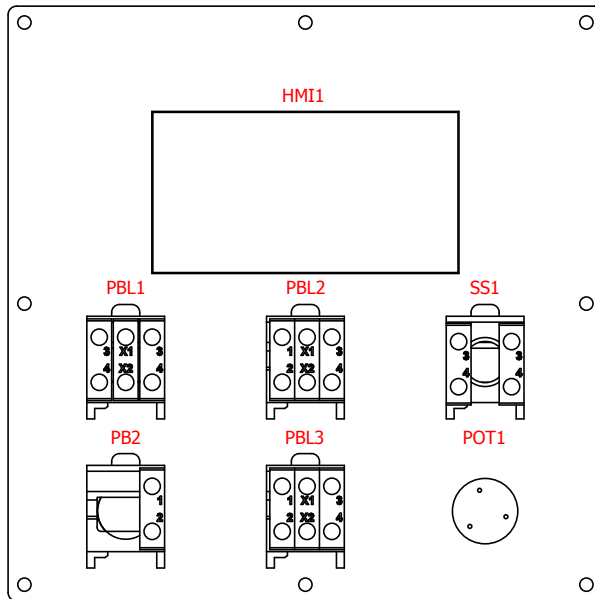

**Wood-Mizer®**

Project Description: HR130EB15-1

Revision: A6.02 Pg Desc: Operator Layout Internal

Mounting Location: +Docs Type: Panel layout

Prev. pg: F3 Page: F4 Next pg: F5 Total Pgs: 20

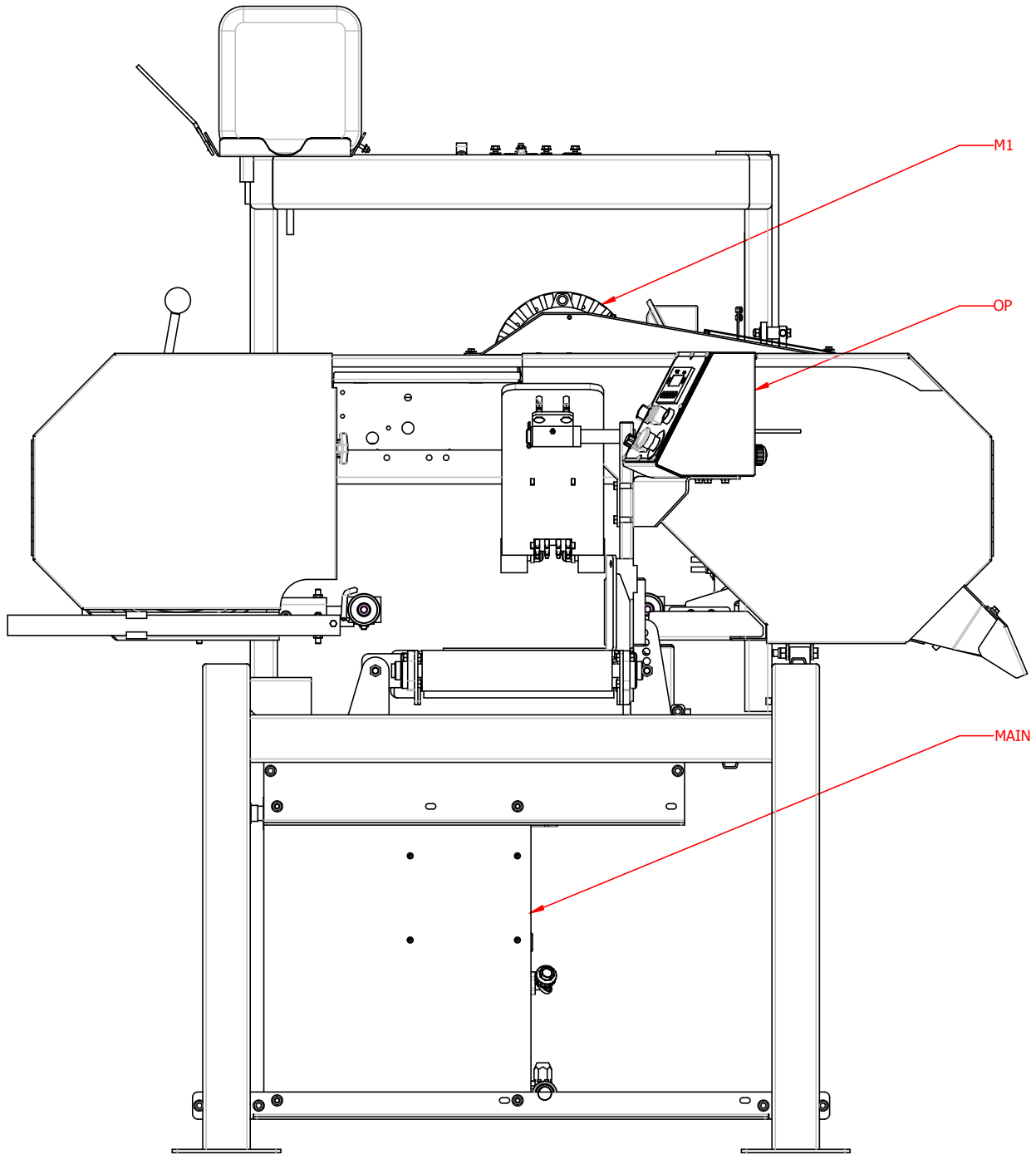

# Wood-Mizer®

Project Description: HR130EB15-1

Revision:	A6.02	Pg Desc:	Machine Layout Front
Mounting Location:	+Docs	Type:	Panel layout
Prev. pg:	F4	Page:	F5
		Next pg:	F6
		Total Pgs:	20

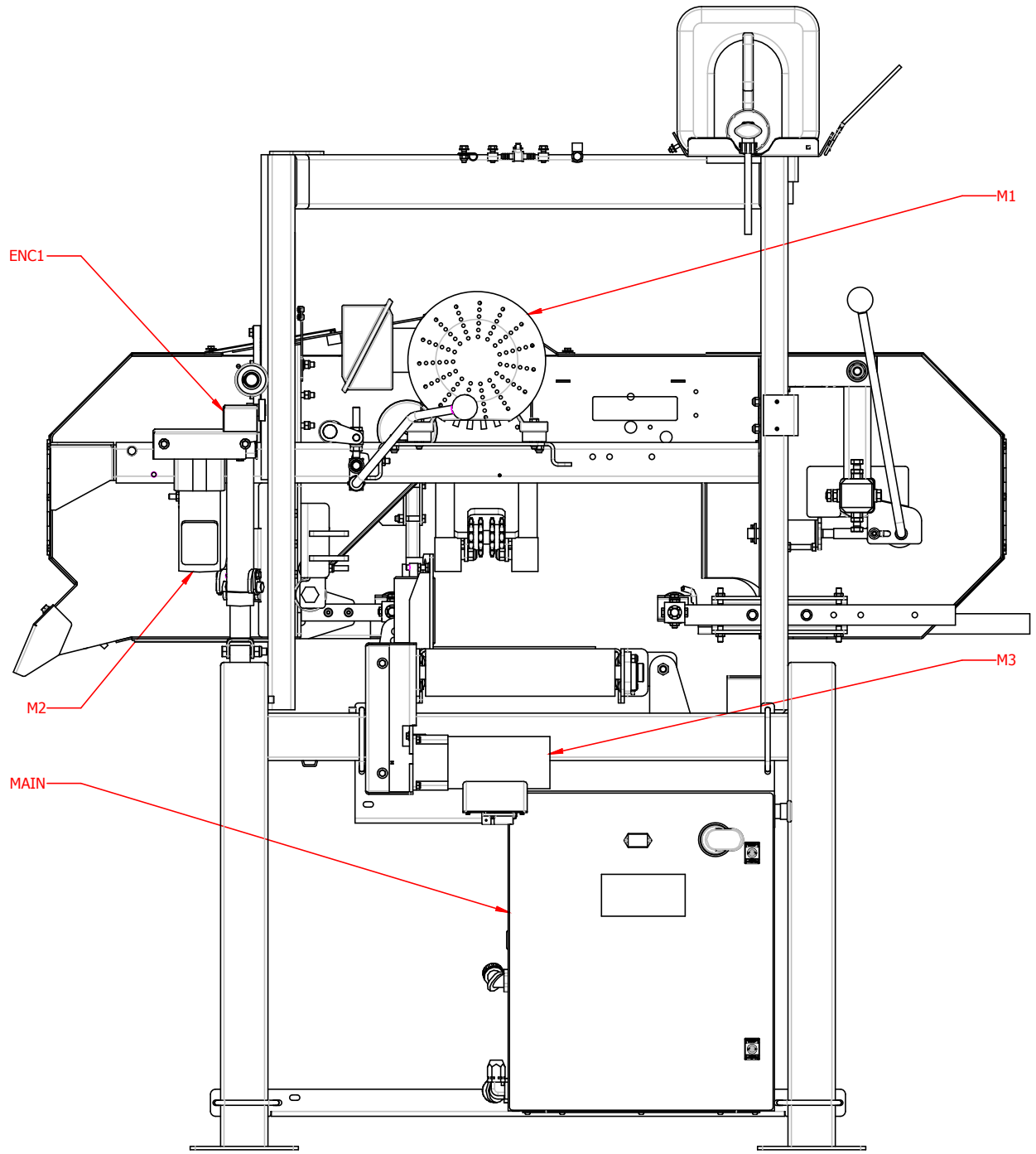

# Wood-Mizer®

Project Description: HR130EB15-1

Revision:	A6.02	Pg Desc:	Machine Layout Back
Mounting Location:	+Docs	Type:	Panel layout
Prev. pg:	F5	Page:	F6
		Next pg:	Total Pgs: 20