

ELECTRICAL INFORMATION

HR120
HR130

Rev. A1.00- A4.07
Rev. A1.00- A6.02

1.1 Schematic

HR120G15/HR120G18

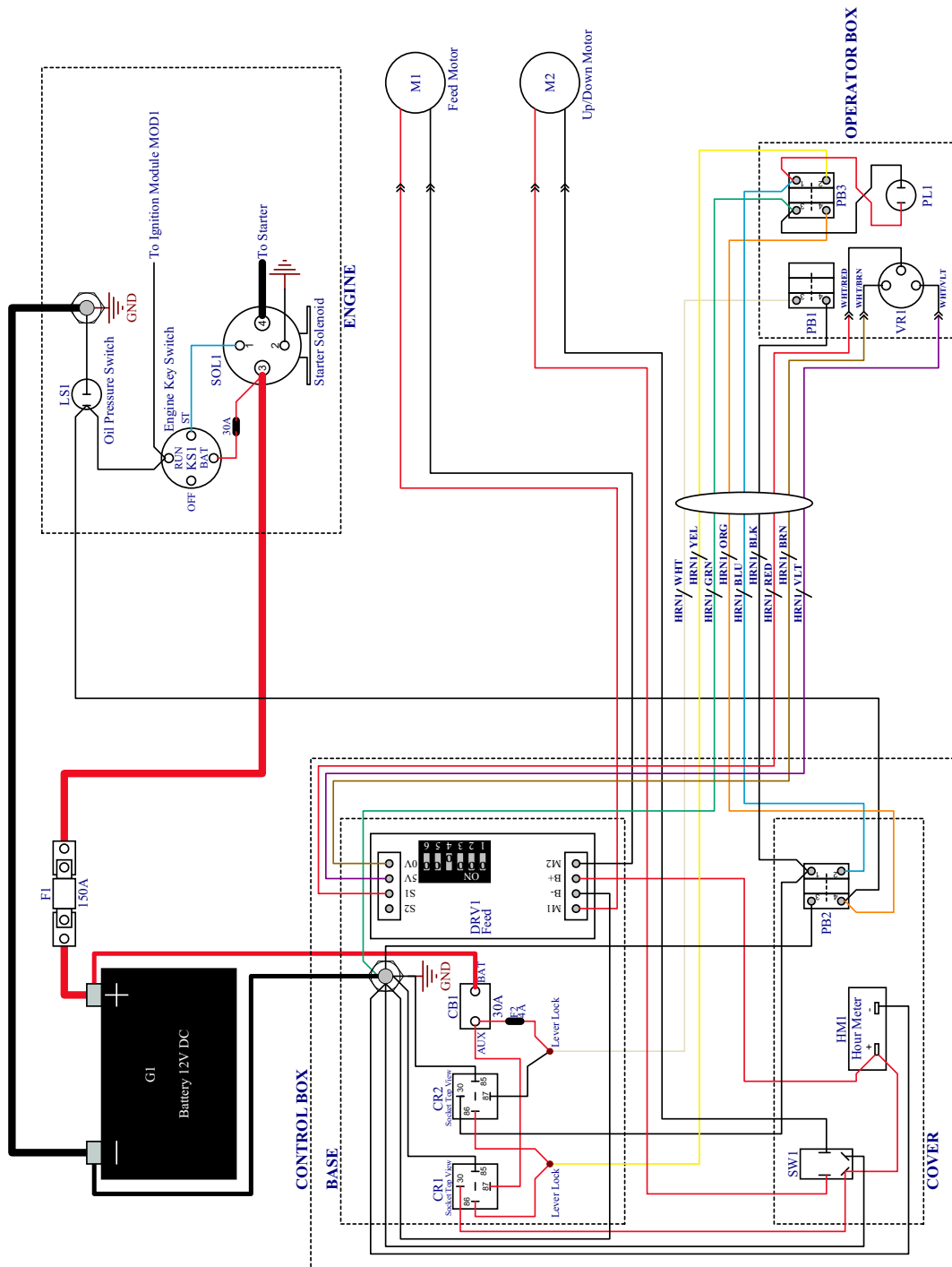

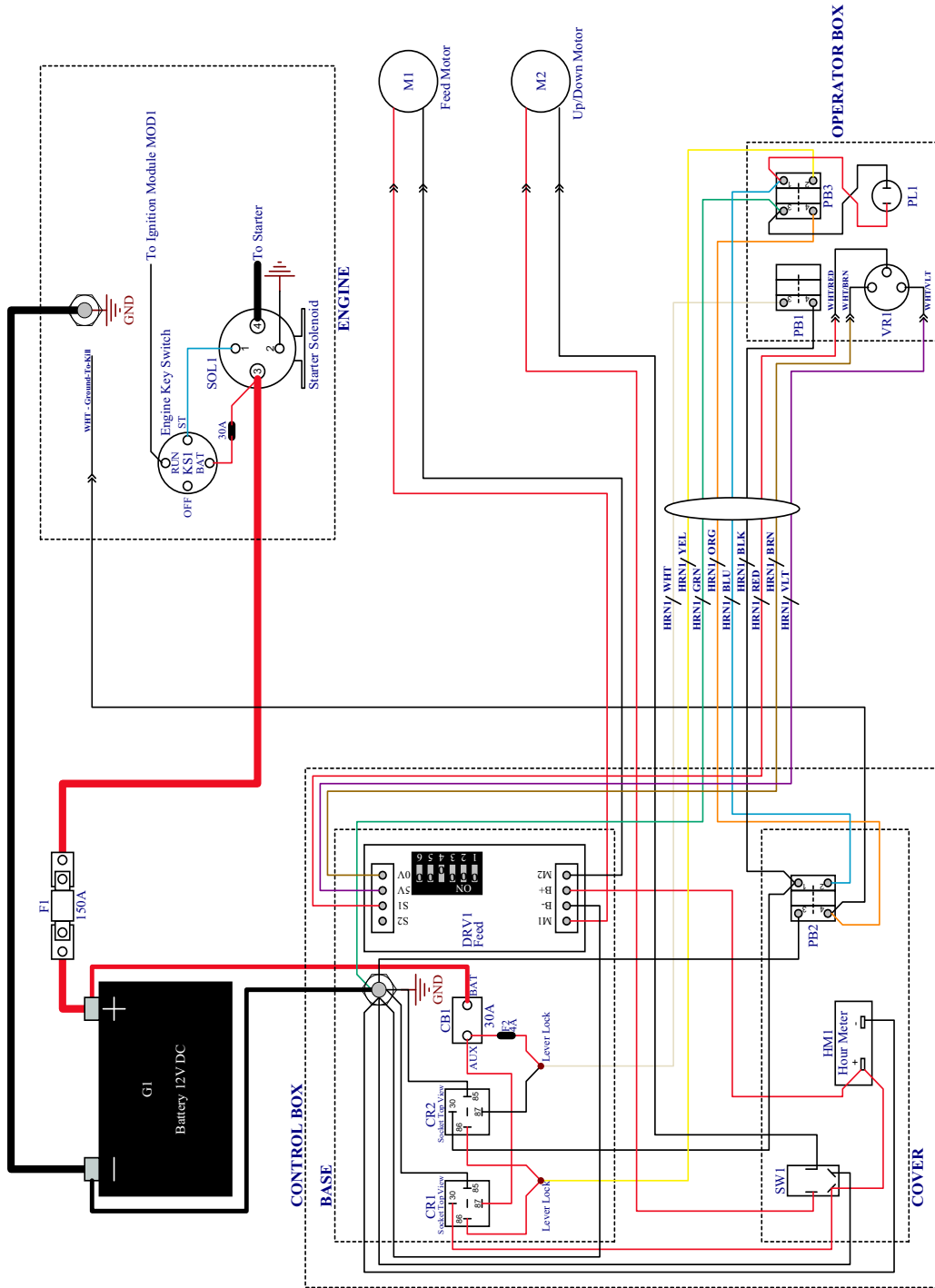

HR120D17

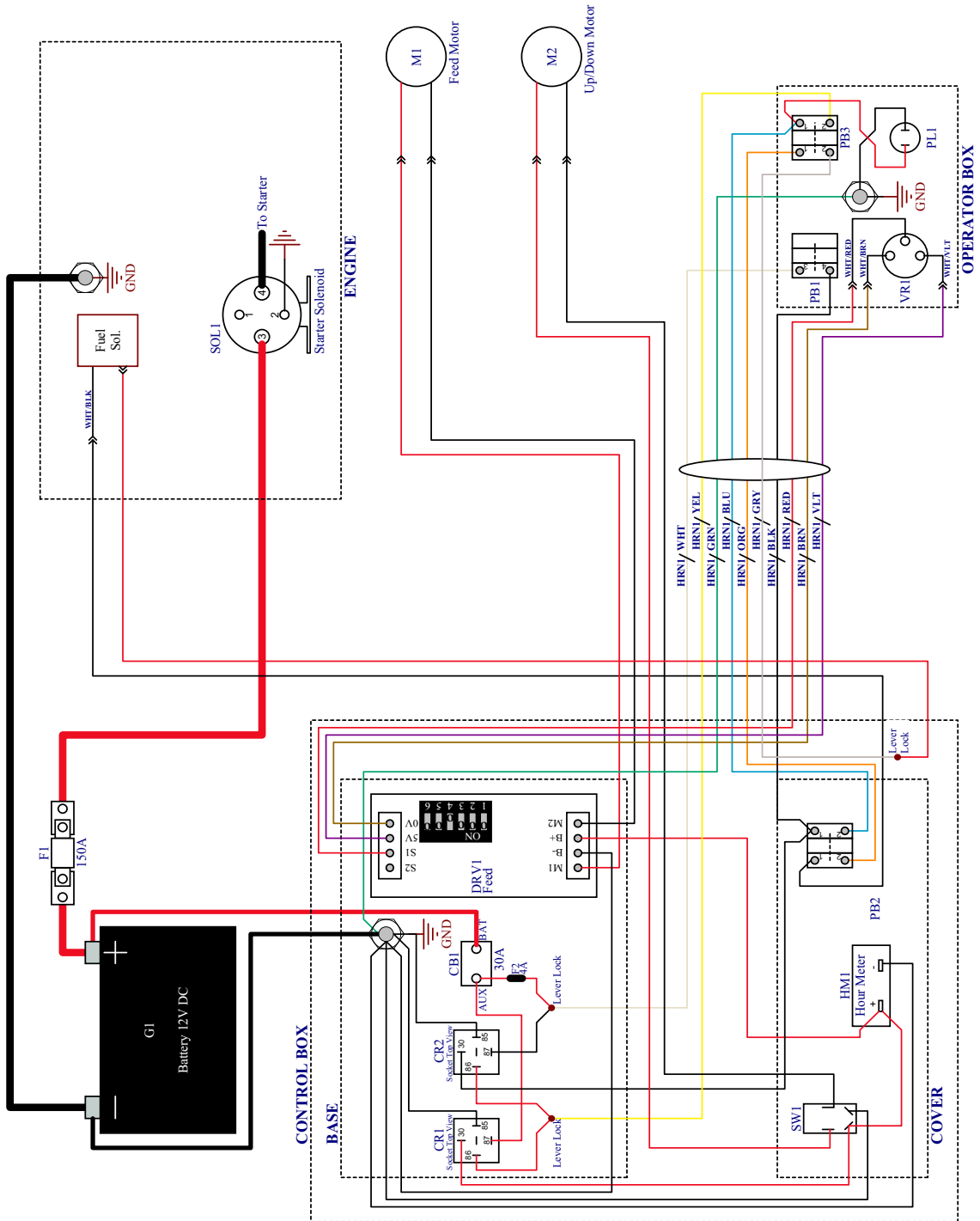

HR120E10/HR120EA10 Rev. A1.01+

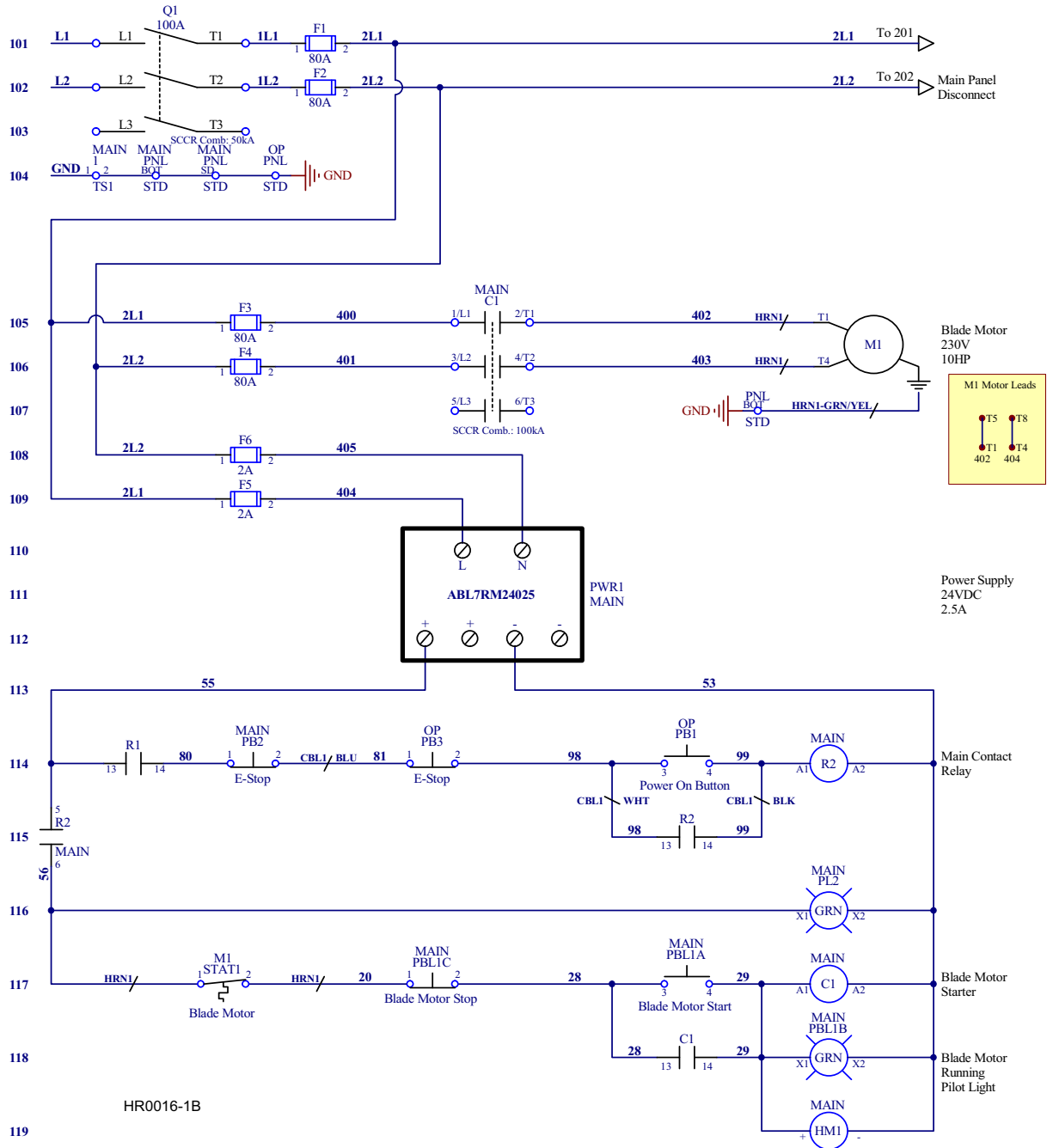

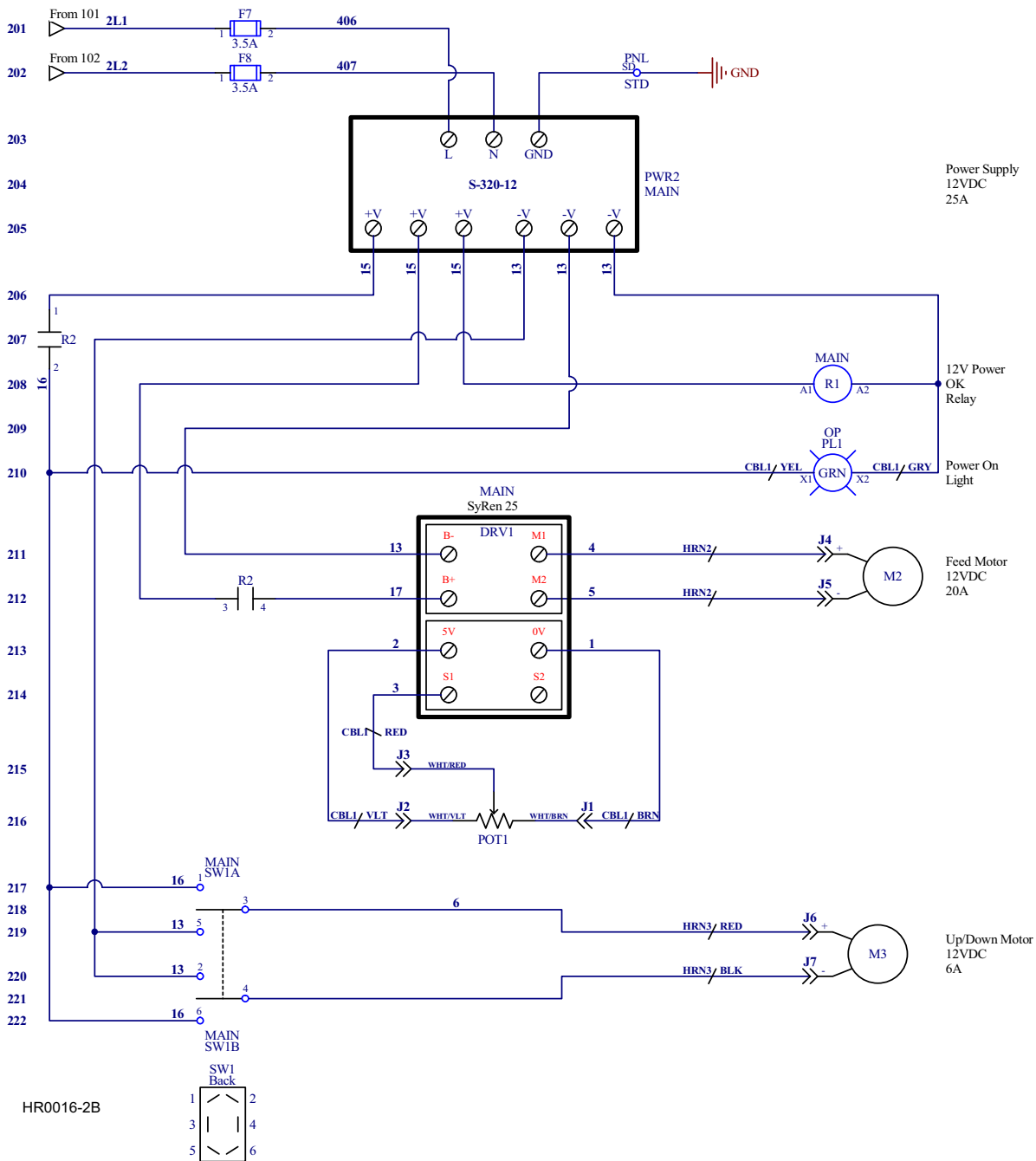

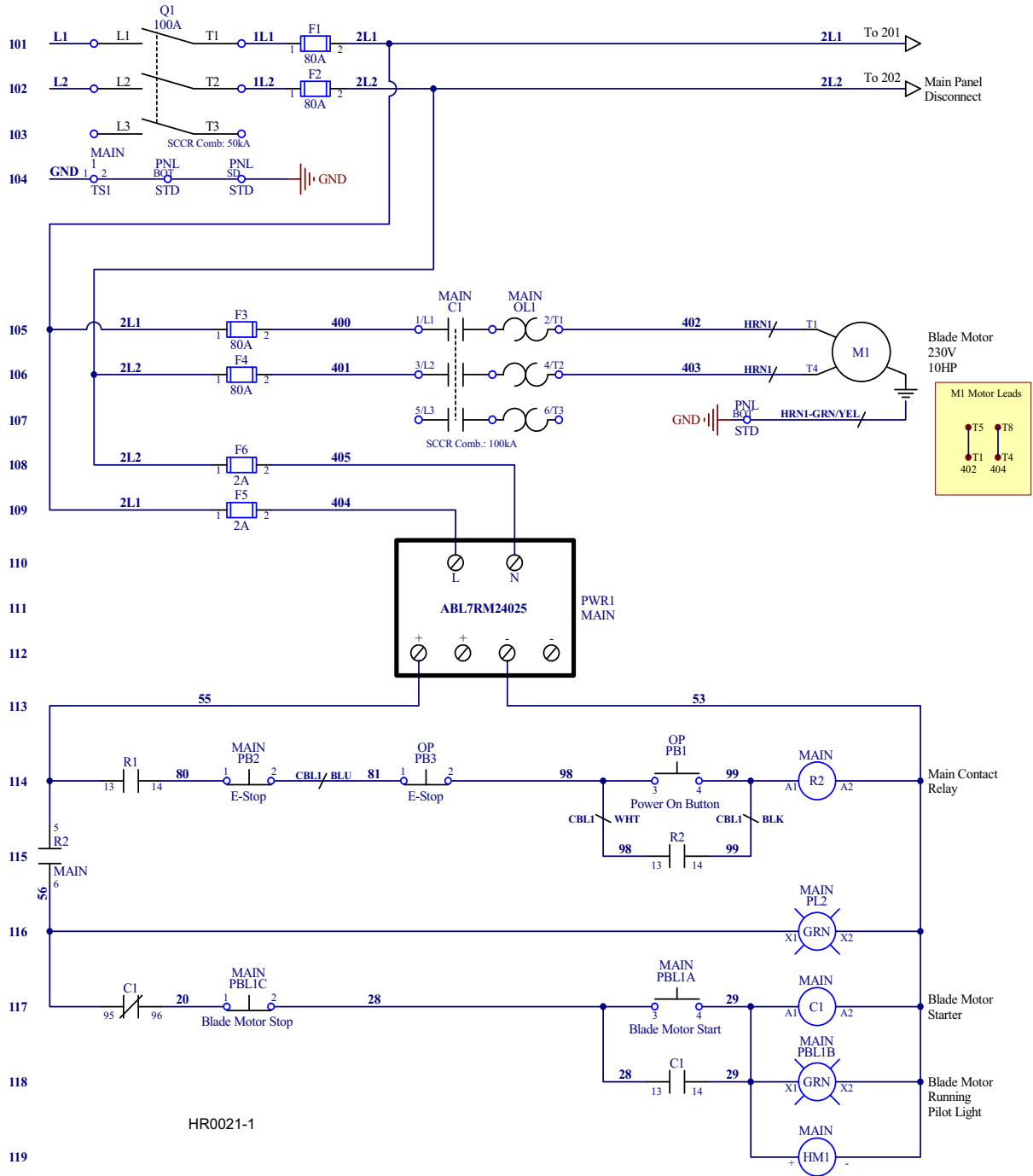

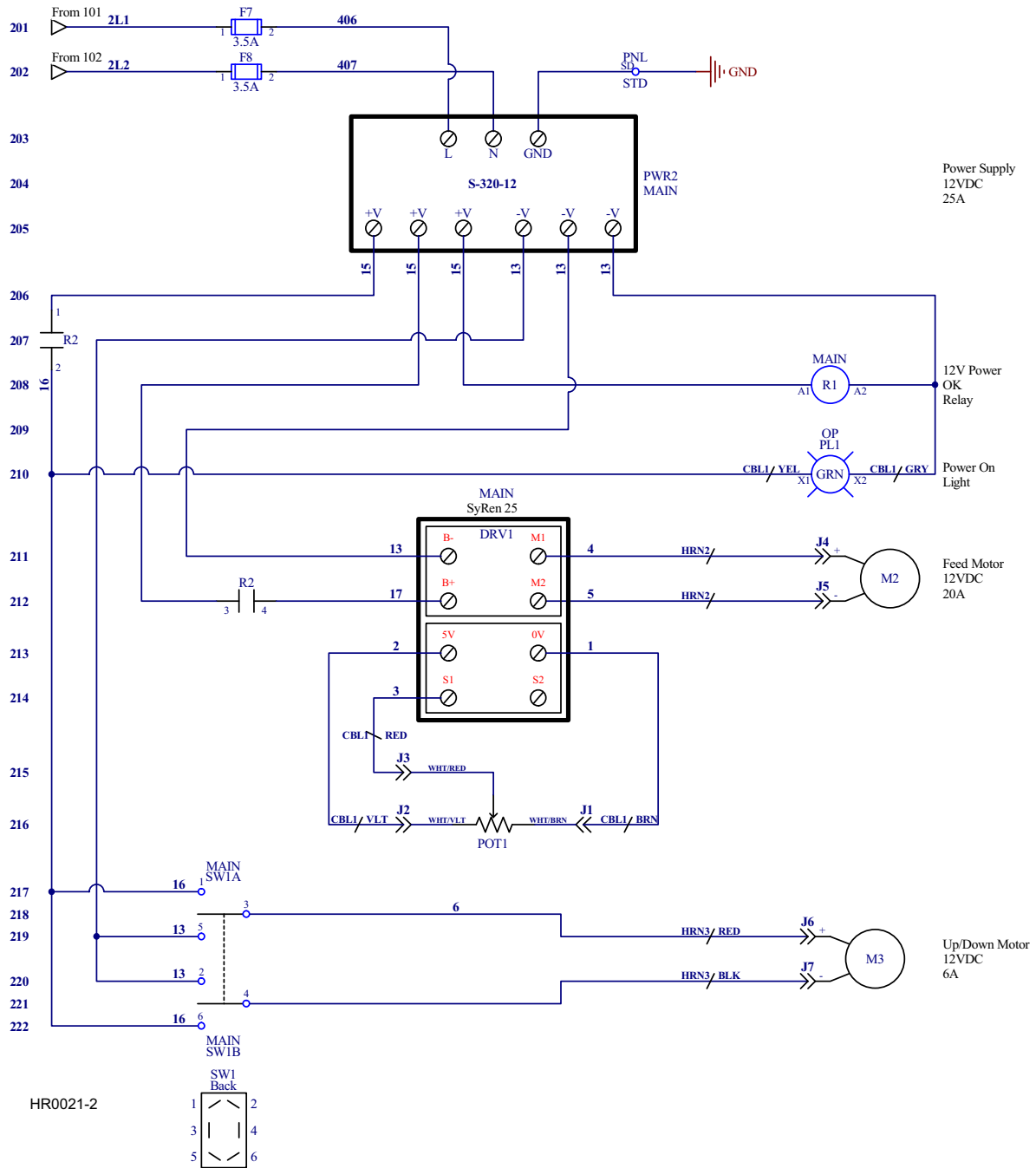

HR130EB15

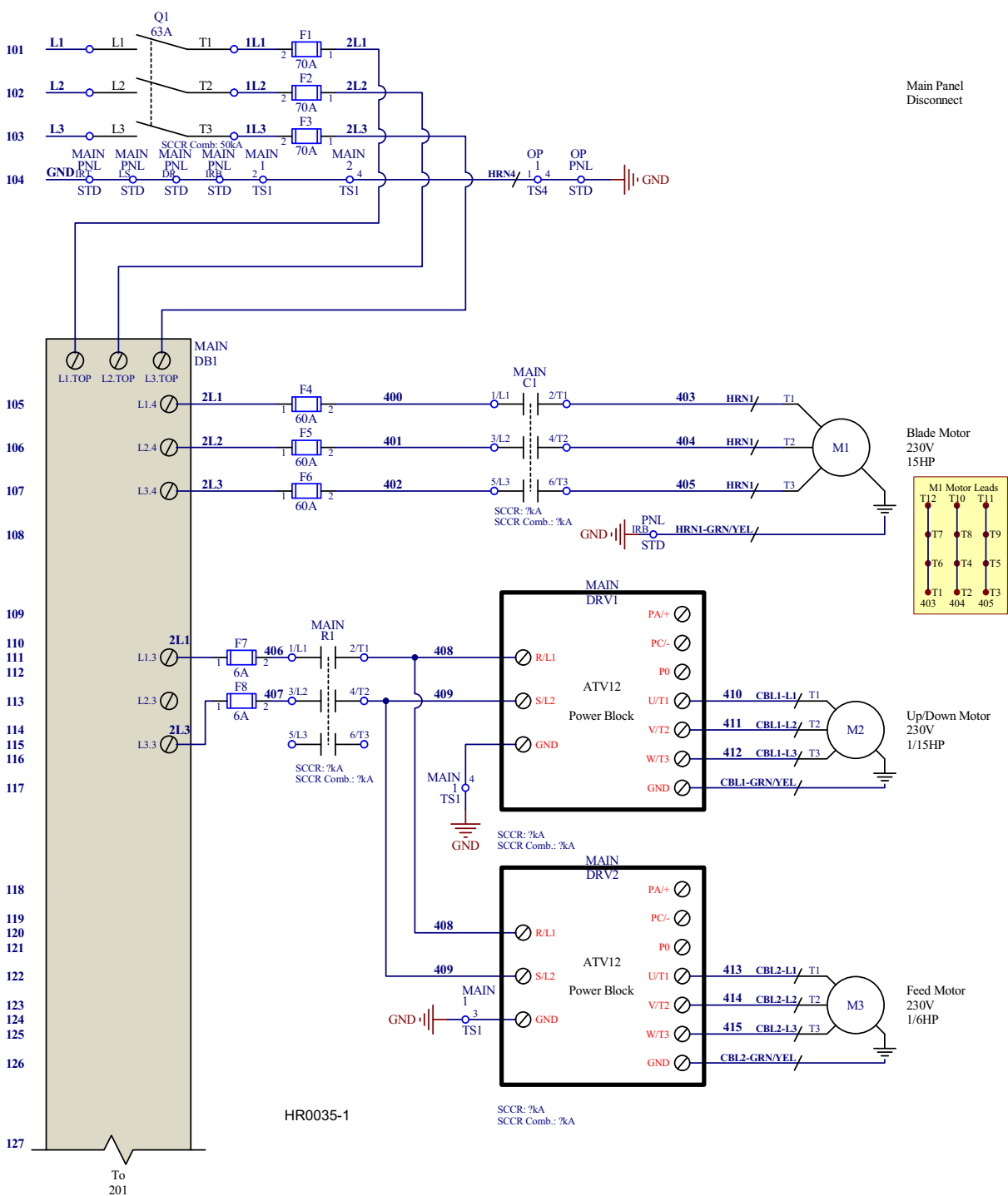

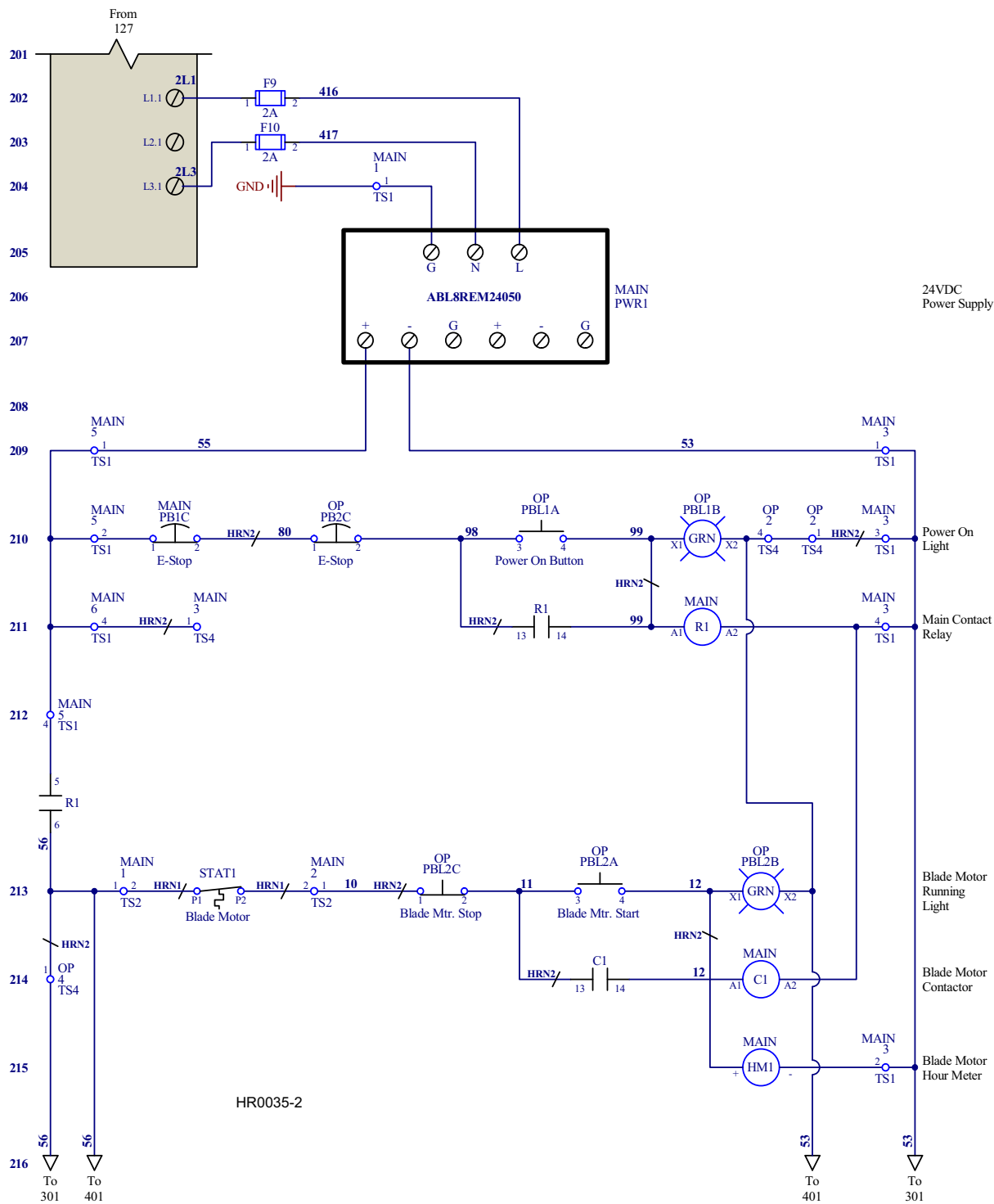

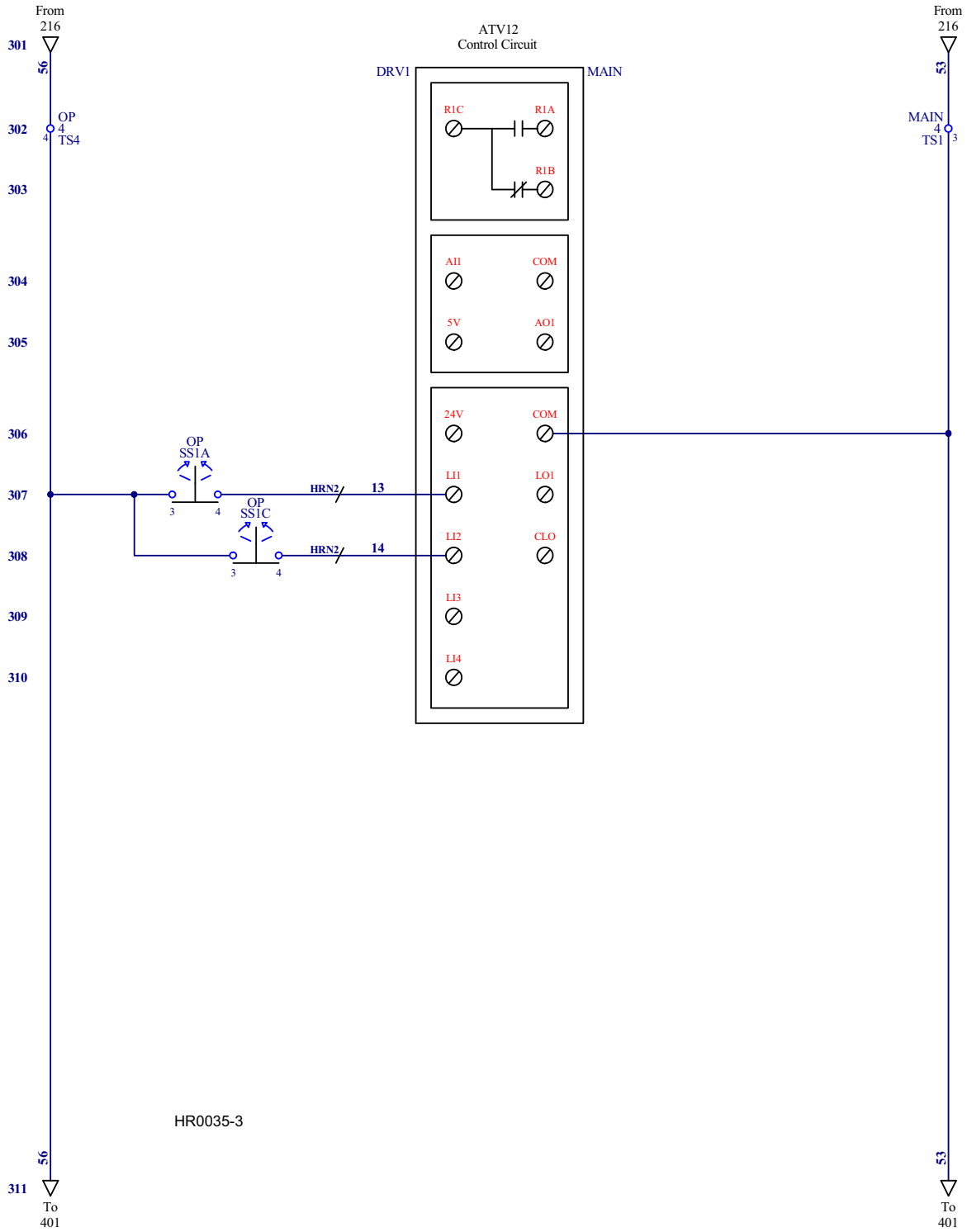

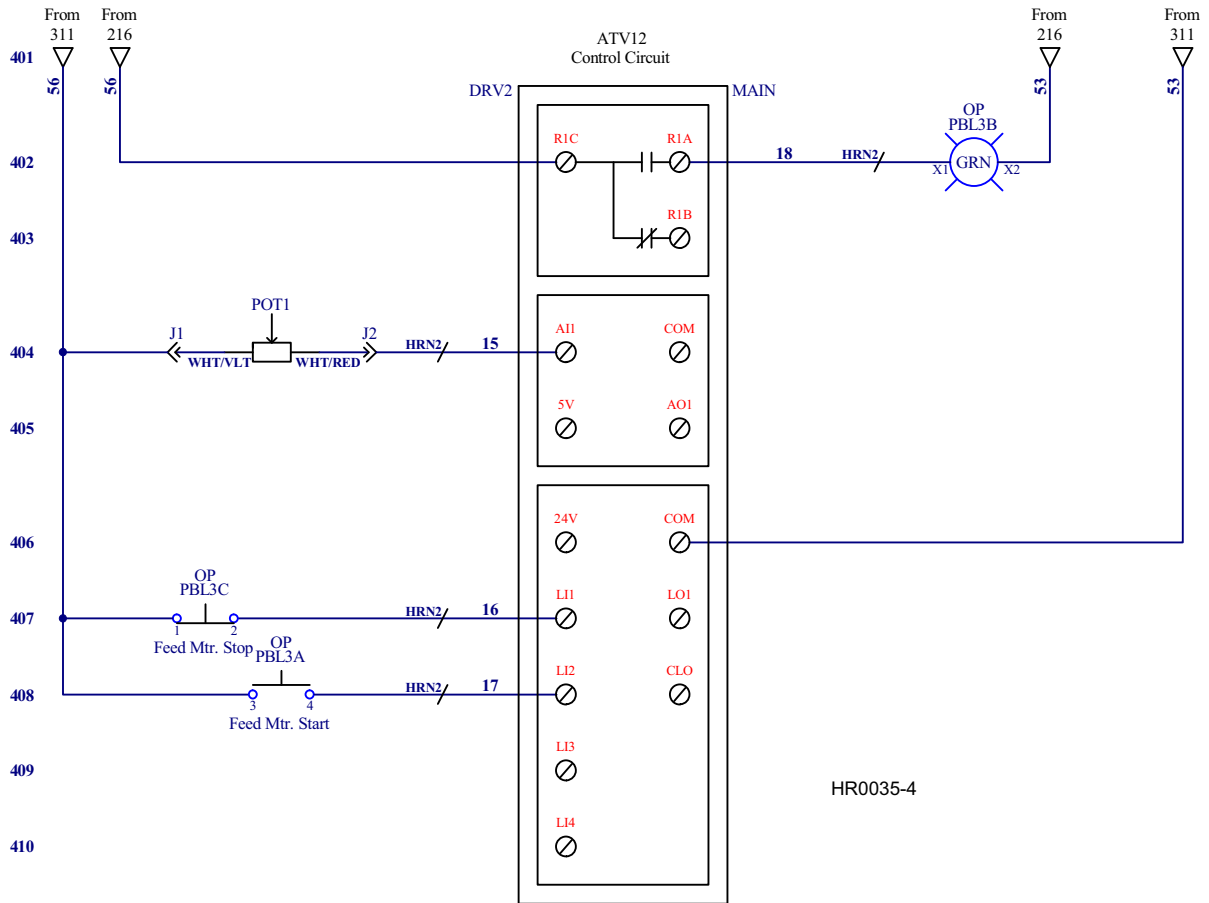

HR130EC15

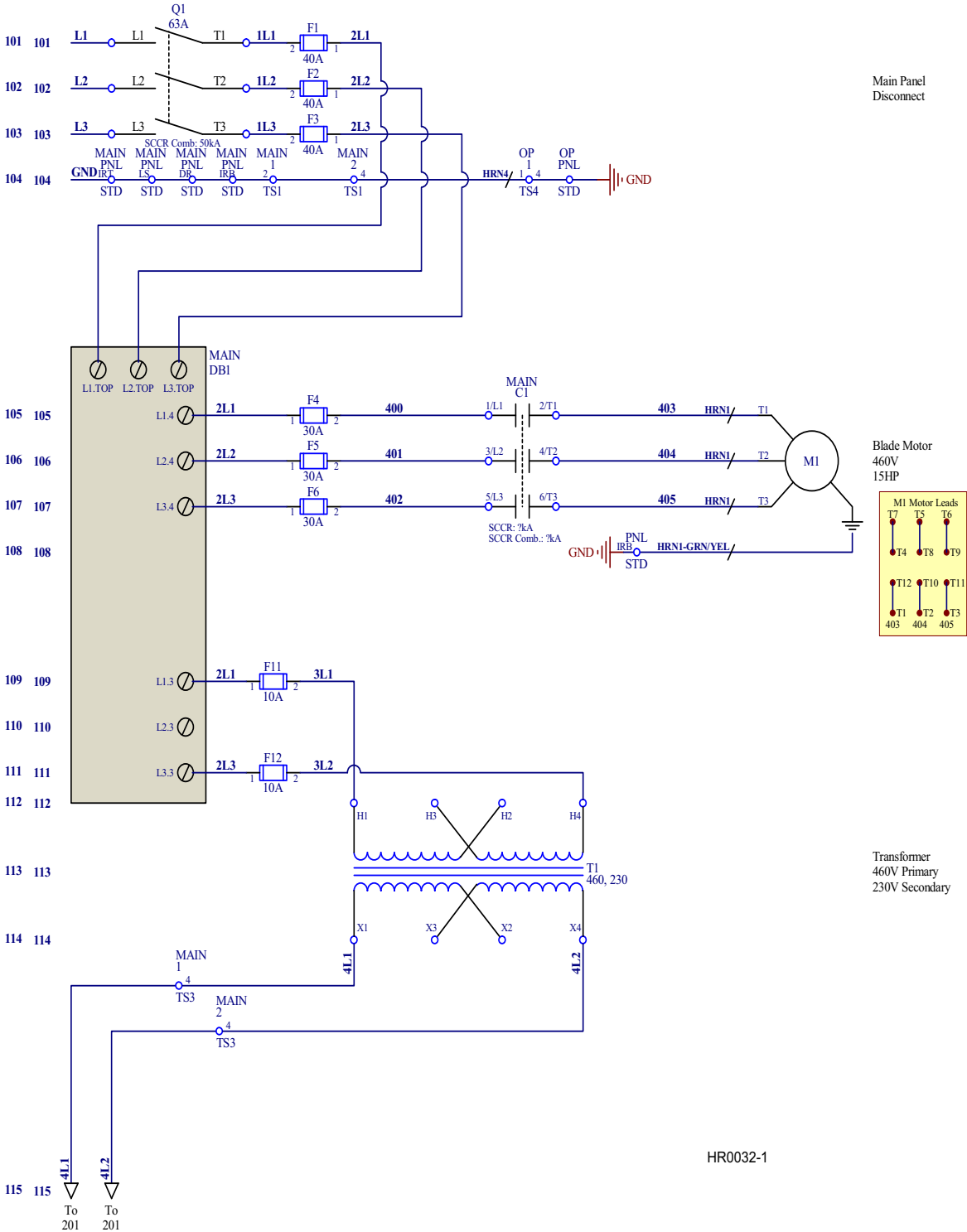

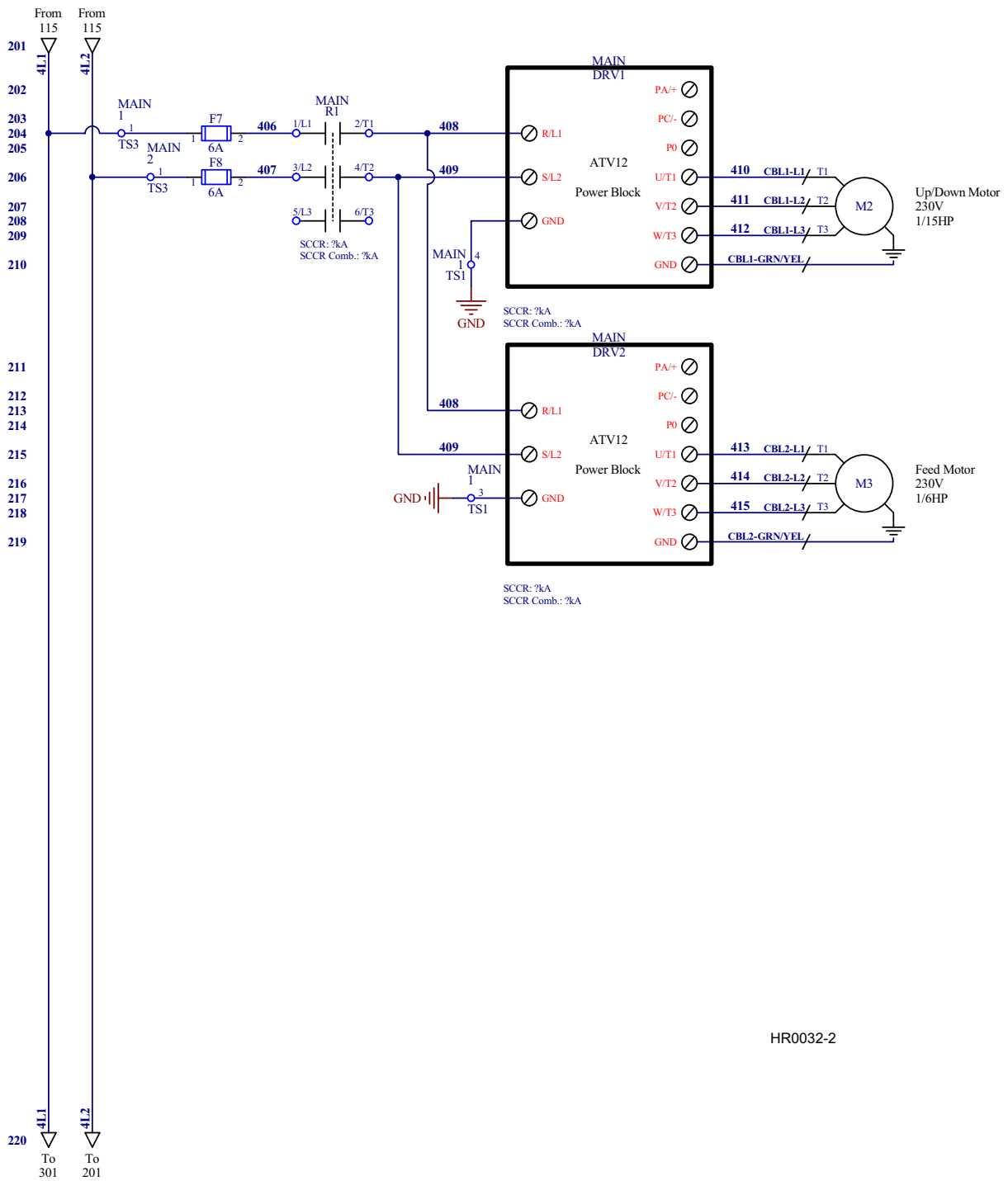

HR0032-2

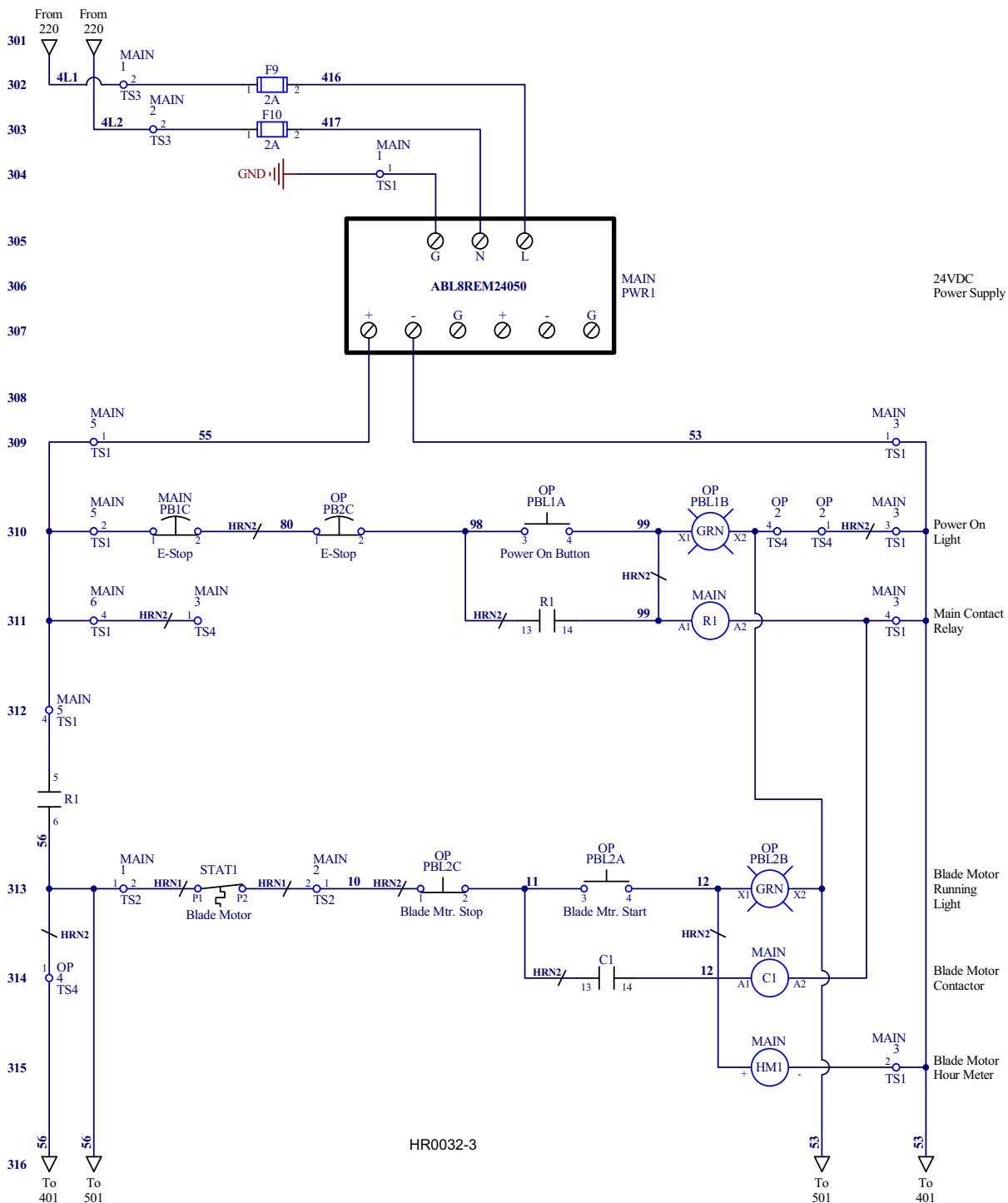

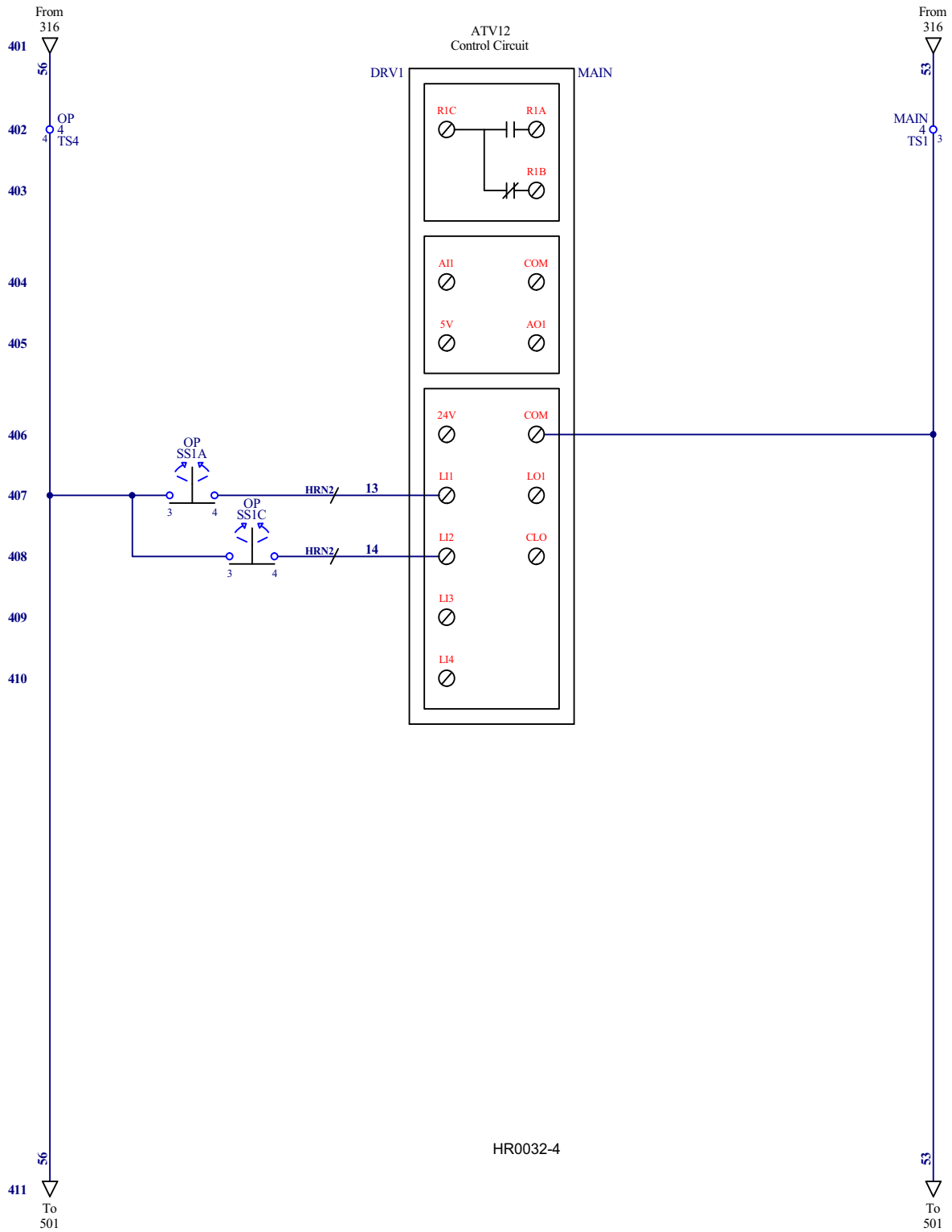

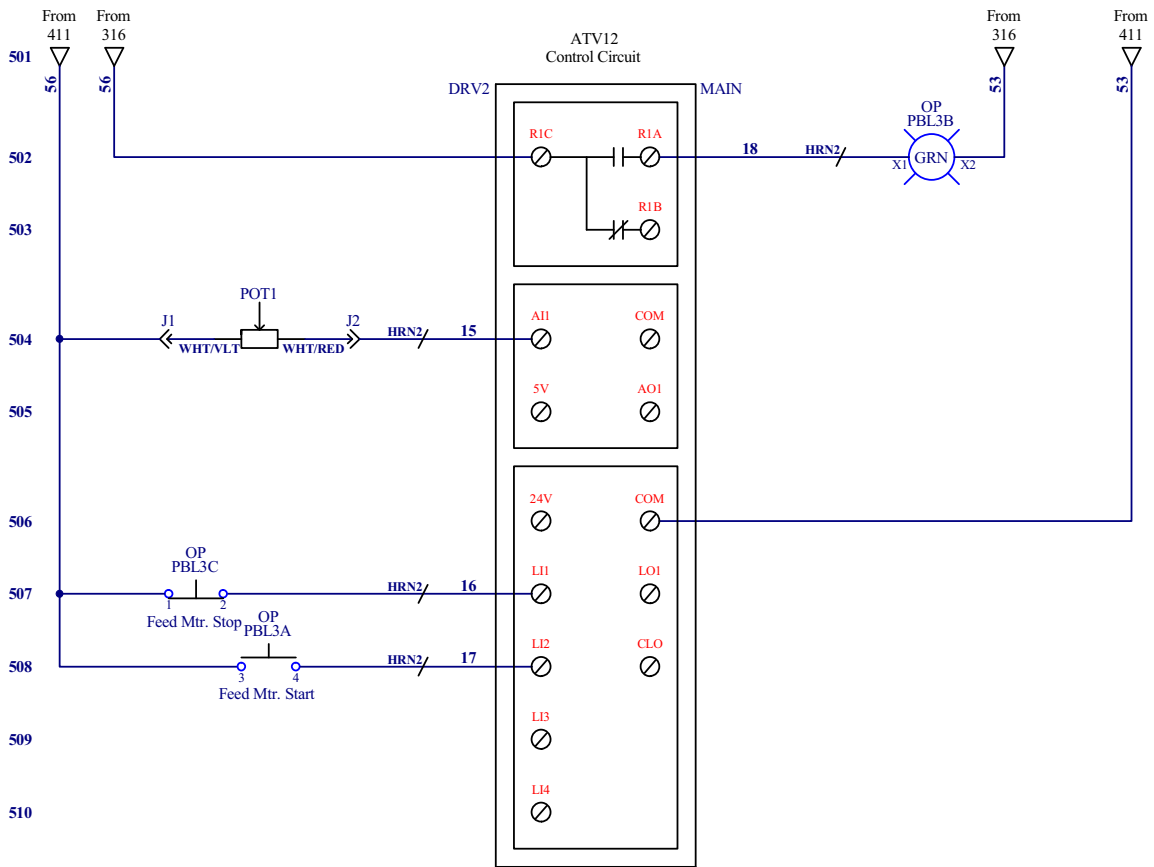

HR0032-5

1.2 Component Layout

HR120G15/HR120G18
HR120G25
HR120D17

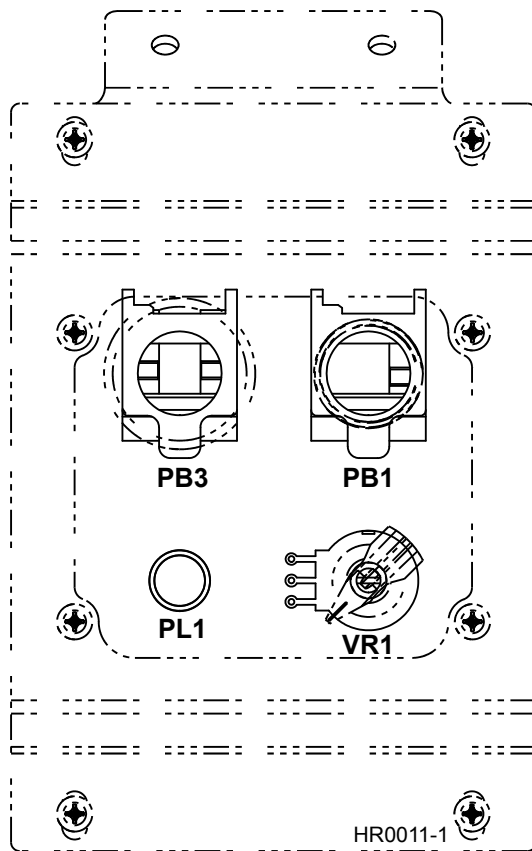

FEED CONTROL

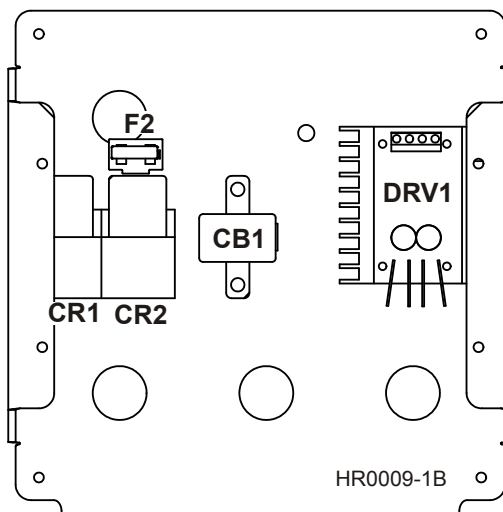
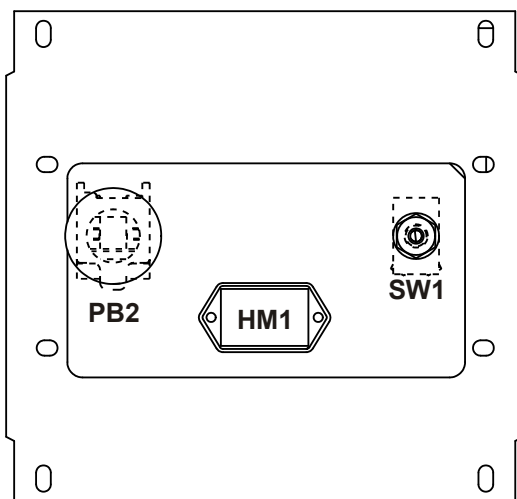

UP/DOWN CONTROL

HR120E10/HR120EA10

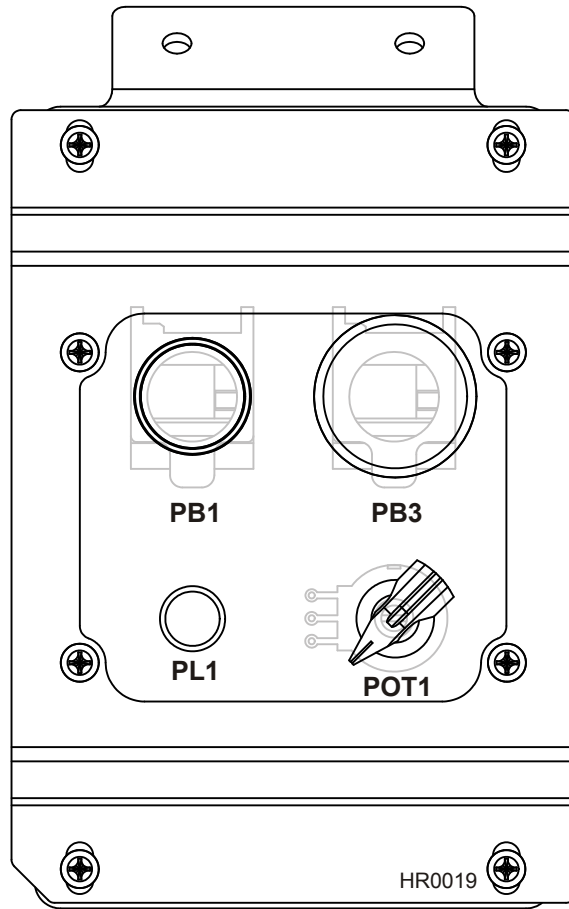

FEED CONTROL

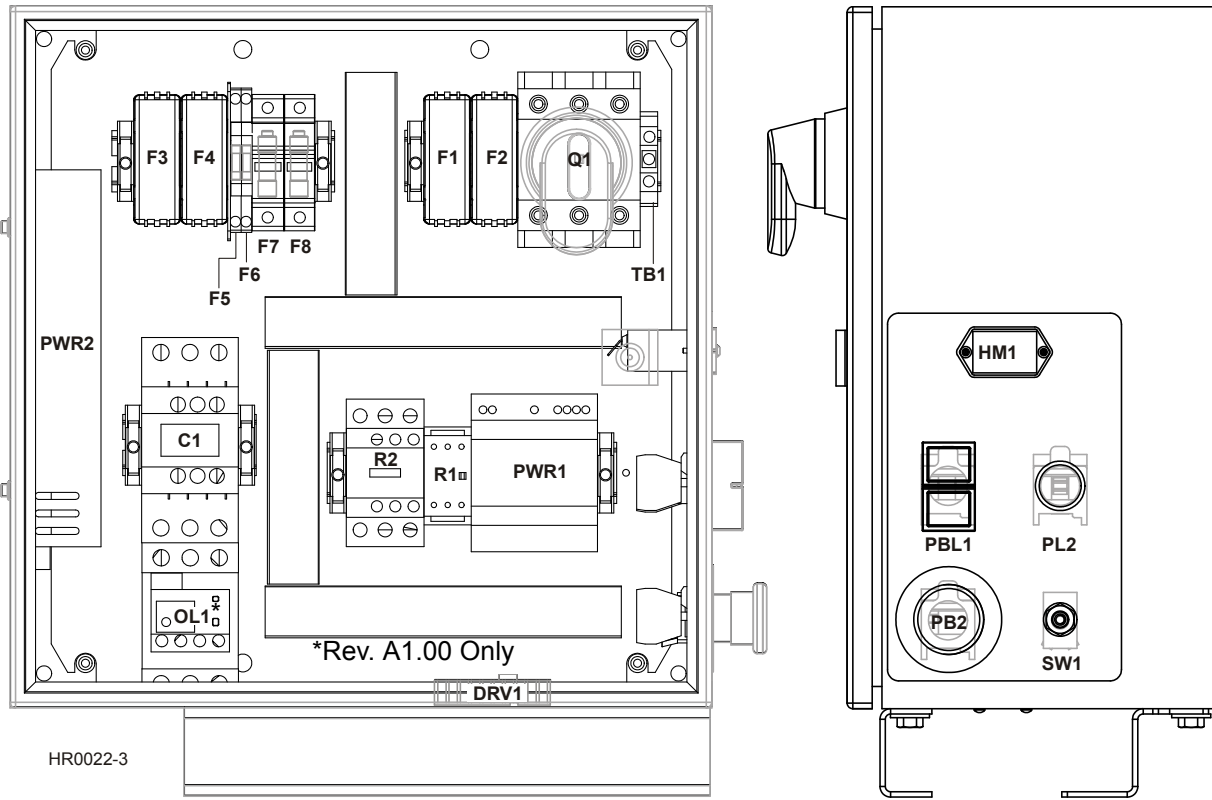

MAIN CONTROL

HR130EB15

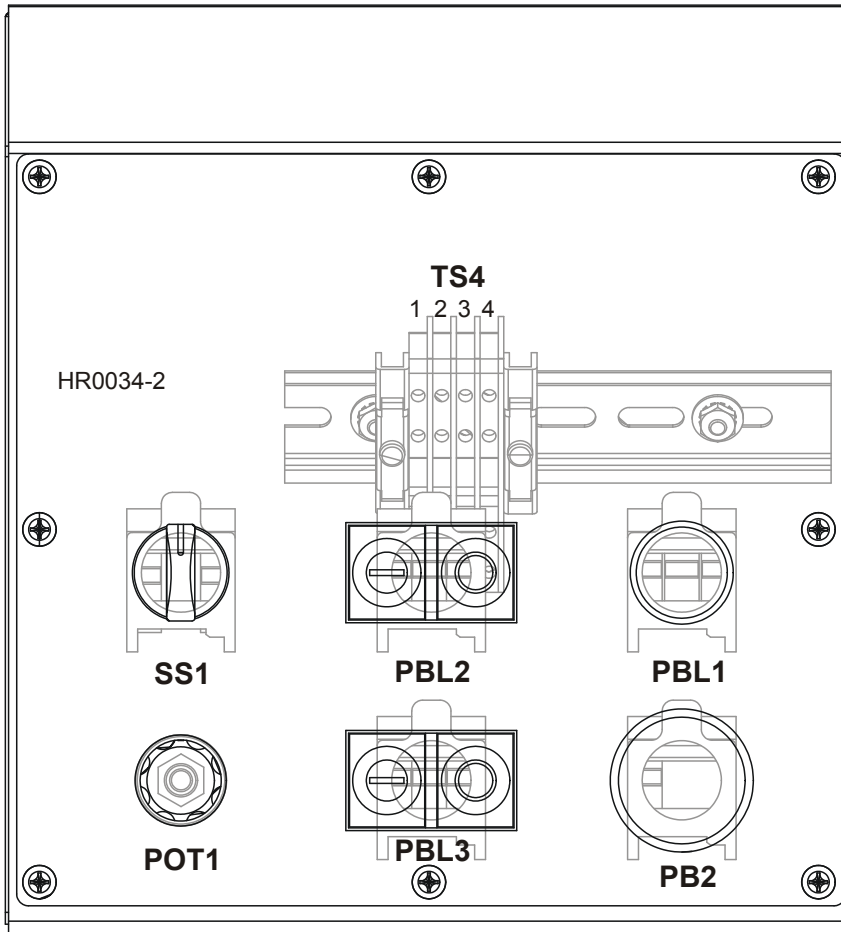

OPERATOR CONTROL

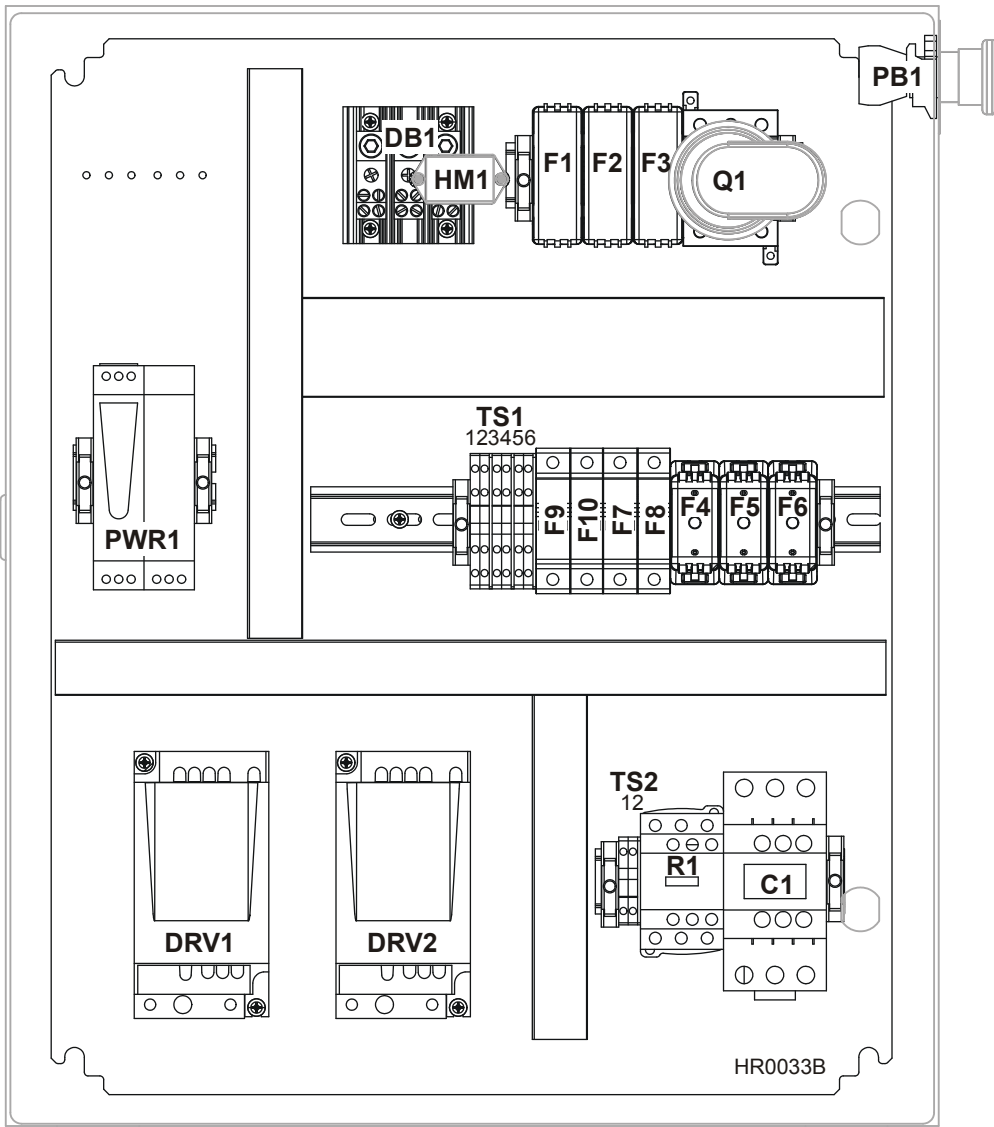

MAIN CONTROL

HR130EC15

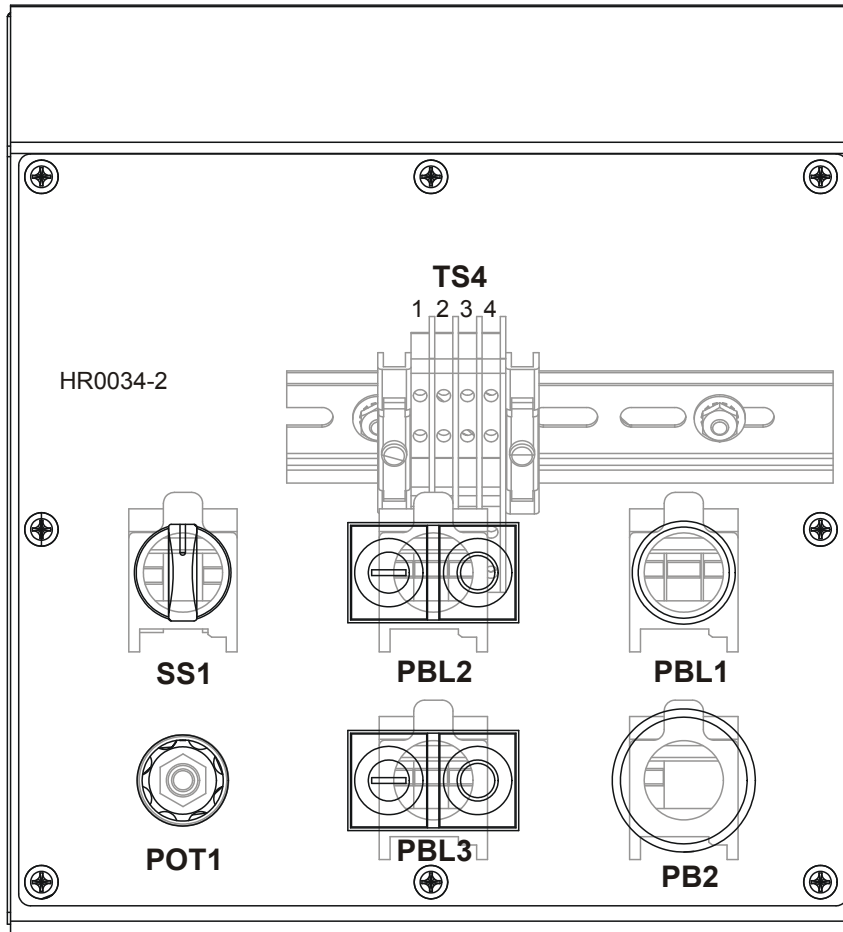

OPERATOR CONTROL

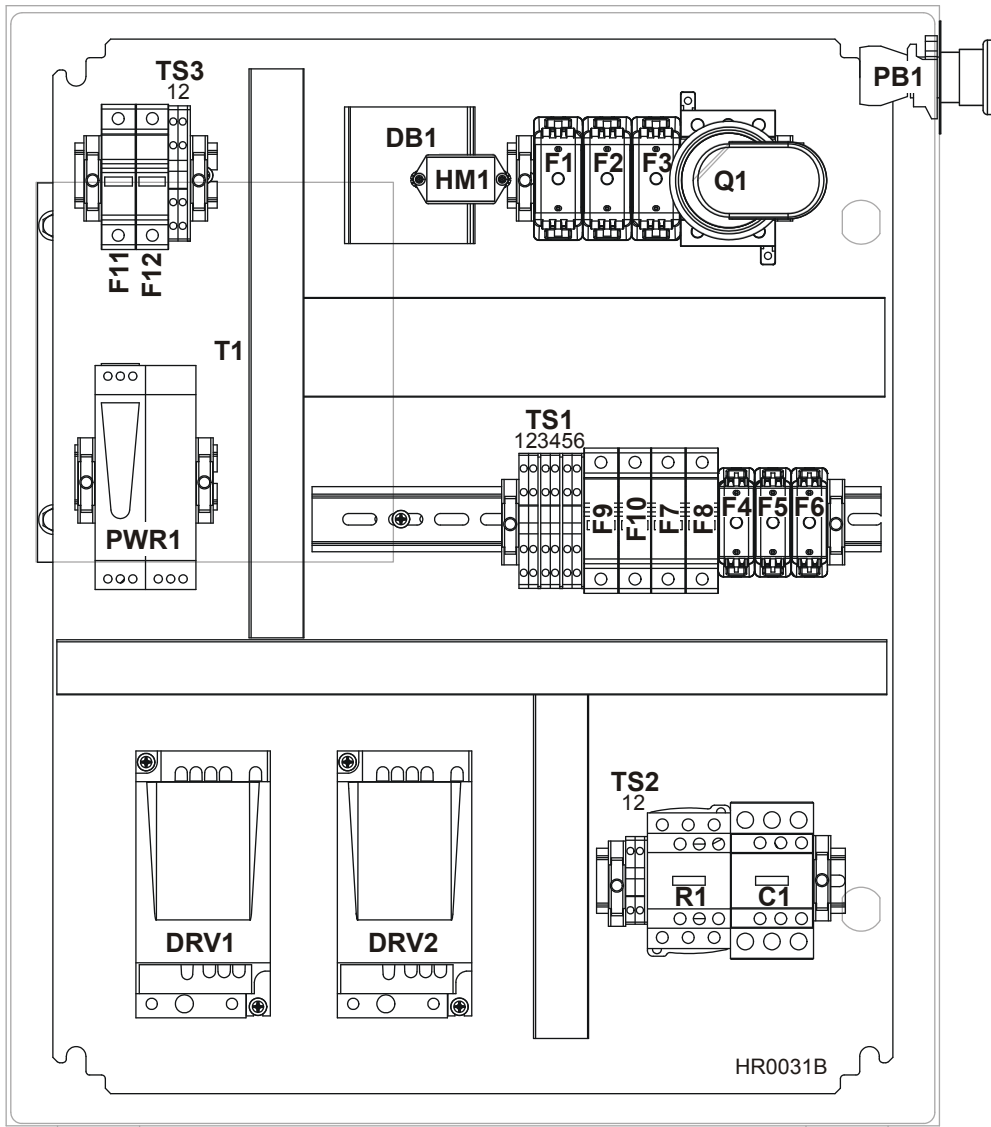

MAIN CONTROL

1.3 Motor Driver Module DIP Switch Settings (HR120 Only)

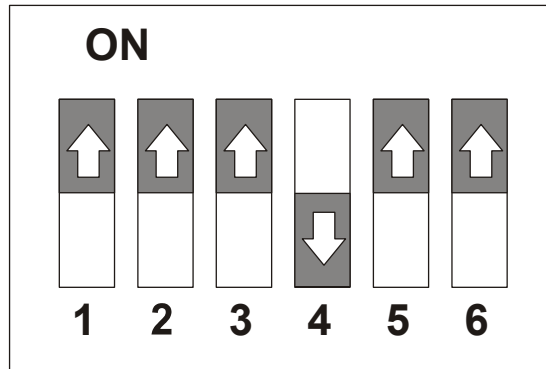

HR0023

1.4 Component List

HR120G15/HR120G18

Component List		
Item	Wood-Mizer Part No.	Description
30A	024150-30	Fuse, 30A ATO Blade Green
CB1	E20431	Breaker, 30A Manual Reset Circuit
CR1, CR2	051335	Relay, ISO 12V Coil w/Diode
DRV1	057829-FR ¹	Driver Kit, 25A DC Motor Field Replacement
F1	052370-150	Fuse Link, 150 Amp, 250 Volt
F2	052354	Fuseholder, ATO 16AWG w/20" Red Wires
	024150-4	Fuse, 4A ATO Pink
G1	028004	Battery, 600U 12 Volt DC
HM1	015401	Hour Meter, 12 Volt DC
KS1	---	Switch, Kohler Key
LS1	051992	Switch, Kohler Oil Pressure
M1	053578	Motor Assembly, HR120 Feed
M2	053577	Motor Assembly, HR120 Up/Down
MOD1	---	Module, Kohler Ignition (G15)
PB1	050152	Switch Head, Green Guarded
	025242	Switch Body, 22mm 1NO XB4
PB2, PB3	024945	Switch Head, Red Push Button 22mm XB4
	050527	Switch Body, 22mm 1NC 1NO ZB4
PL1	E20483	Light, Green 12V .187 Tabs
SOL1	038425	Solenoid, Kohler Starter
SW1	024200	Switch, DPDT 21A Reverse Mom. Spade Toggle
VR1	053572	Switch Assembly, HR120 Feed Rate Pot
	P06257	Knob, Speed Control

¹ Field Replacement Kit 057829-FR replaces Driver Module 057829 originally supplied prior to 1/10. Module B-, B+, M1 & M2 connections changed from terminal block to spade terminal to allow proper wiring size to be used. Kit includes new driver module w/spade terminals, quick connect terminals and instructions.

HR120G25

Component List		
Item	Wood-Mizer Part No.	Description
30A	024150-30	Fuse, 30A ATO Blade Green
CB1	E20431	Breaker, 30A Manual Reset Circuit
CR1, CR2	051335	Relay, ISO 12V Coil w/Diode
DRV1	057829-FR ¹	Driver Kit, 25A DC Motor Field Replacement
F1	052370-150	Fuse Link, 150 Amp, 250 Volt
F2	052354	Fuseholder, ATO 16AWG w/20" Red Wires
	024150-4	Fuse, 4A ATO Pink
G1	028004	Battery, 600U 12 Volt DC
HM1	015401	Hour Meter, 12 Volt DC
KS1	---	Switch, Kohler Key
M1	053578	Motor Assembly, HR120 Feed
M2	053577	Motor Assembly, HR120 Up/Down
MOD1	---	Module, Kohler Ignition
PB1	050152	Switch Head, Green Guarded
	025242	Switch Body, 22mm 1NO XB4
PB2, PB3	024945	Switch Head, Red Push Button 22mm XB4
	050527	Switch Body, 22mm 1NC 1NO ZB4
PL1	E20483	Light, Green 12V .187 Tabs
SOL1	---	Solenoid, Kohler Starter
SW1	024200	Switch, DPDT 21A Reverse Mom. Spade Toggle
VR1	053572	Switch Assembly, HR120 Feed Rate Pot
	P06257	Knob, Speed Control

¹ Field Replacement Kit 057829-FR replaces Driver Module 057829 originally supplied prior to 1/10. Module B-, B+, M1 & M2 connections changed from terminal block to spade terminal to allow proper wiring size to be used. Kit includes new driver module w/spade terminals, quick connect terminals and instructions.

HR120D17

Component List		
Item	Wood-Mizer Part No.	Description
CB1	E20431	Breaker, 30A Manual Reset Circuit
CR1, CR2	051335	Relay, ISO 12V Coil w/Diode
DRV1	057829-FR ¹	Driver Kit, 25A DC Motor Field Replacement
F1	052370-150	Fuse Link, 150 Amp, 250 Volt
F2	052354	Fuseholder, ATO 16AWG w/20" Red Wires
	024150-4	Fuse, 4A ATO Pink
G1	028004	Battery, 600U 12 Volt DC
HM1	015401	Hour Meter, 12 Volt DC
M1	053578	Motor Assembly, HR120 Feed
M2	053577	Motor Assembly, HR120 Up/Down
PB1	050152	Switch Head, Green Guarded
	025242	Switch Body, 22mm 1NO XB4
PB2, PB3	024945	Switch Head, Red Push Button 22mm XB4
	025161	Switch Body, 22mm 1NC ZB4
	050540	Contact, NC ZBE102
PL1	E20483	Light, Green 12V .187 Tabs
SW1	024200	Switch, DPDT 21A Reverse Mom. Spade Toggle
VR1	053572	Switch Assembly, HR120 Feed Rate Pot
	P06257	Knob, Speed Control

¹ Field Replacement Kit 057829-FR replaces Driver Module 057829 originally supplied prior to 1/10. Module B-, B+, M1 & M2 connections changed from terminal block to spade terminal to allow proper wiring size to be used. Kit includes new driver module w/spade terminals, quick connect terminals and instructions.

HR120E10/HR120EA10

Component List		
Item	Wood-Mizer Part No.	Description
C1	053604 ¹	Contact, 65A 3P 24VDC Coil Compact
DRV1	057829-1	Driver, 25A DC Motor w/Spade Terminals
F1 - F4	053586	Fuseholder, Cube 100A
	053587	Fuse, 80A Class J Cube
F5 - F6	052512	Fuse Block, 2P Class CC 30A Ind. DIN
	E22716 ¹	Fuse, 2A 600V Class CC
F7 - F8	052512	Fuseholder, 2P Class CC Finger Safe
	052721	Fuse, 3.5A 600V Class CC Delay
HM1	015401	Hour Meter, 12 Volt DC
M1	036214 ²	Motor, 10HP Single Phase 60Hz
M2	053578	Motor Assembly, HR120 Feed
M3	053577	Motor Assembly, HR120 Up/Down
OL1	053692 ³	Relay, 37-50A Class 10 Overload
PB1	050152	Switch Head, Green Guarded
	025242	Switch Body, 22mm 1NO XB4
PB2, PB3	024945	Switch Head, Red Push Button 22mm XB4
	025161	Switch Body, 22mm 1NC ZB4
PBL1	051746	Switch Operator, 2 Button w/Pilot Red/Green
	052501	Boot, Clear Sealing ZB Switch
	025236-31	Switch Body, 22mm Green LED 1NO 24V ZB4
	050540	Contact, NC ZBE102
PL1	E20483	Light, Green 12V .187 Tabs
PL2	024970-3	Pilot Light, Green 24V 22mm LED XB4
POT1	053572	Switch Assembly, HR120 Feed Rate Pot
	P06257	Knob, Speed Control
PWR1	053591	Power Supply, 24VDC 60W
PWR2	053592	Power Supply, 12VDC 320W
Q1	050906-1 ⁴	Disconnect, 100Amp 3P Non-Fused 6mm
	050907-1 ⁴	Operator, Red/Yellow Pistol Grip 6mm
	050908-1 ⁴	Shaft, Pistol Grip Disconnect 290mm x 6mm
R1	053590	Relay, Control 12VDC 2NO
R2	052465	Contact, 32A 3P 24VDC Coil
SW1	024200	Switch, DPDT 21A Reverse Mom. Spade Toggle
TB1	053585	Terminal Block, Grounding

¹ 65A Contactor 053604 replaced 50A Contactor 053601 9/10 to provide adequate horsepower rating. Fuse E22716 replaces 050889 to meet CSA Standards.

² Motor 036214 modified to motor equipped with overload thermostats (Rev. A1.01). If replacing the motor on previous revisions equipped with an overload relay in the control cabinet, leave thermostats unconnected.

³ Rev. A1.00 Only. Blade motor modified Rev. A1.01 to motor equipped with overload thermostats.

⁴ 5mm Disconnect Shaft OXP5X265 replaced by vendor with 6mm shaft OXP6X290 (2/10). Replacement of any disconnect component requires replacement of disconnect, shaft and operator handle (050906-1, 050907-1 & 050908-1).

HR130EB15

Component List		
Item	Wood-Mizer Part No.	Description
C1	053601	Contactora, 50A 3P 24VDC D-A Series
DB1	069701	Distribution Block, 3P 1 to 4
	069728	Cover, Distribution Block
DRV1	069799	Drive Assembly, HR130 Up/Down (Drive+Software)
DRV2	069800	Drive Assembly, HR130 Feed (Drive+Software)
F1 - F3	053586	Fuseholder, Cube 100A
	069707	Fuse, 70A Class J Cube
F4 - F6	053717	Fuseholder, Cube 60A
	069708	Fuse, 60A Class J Cube
F7 - F8	052512	Fuseholder, 2P Class CC Finger Safe
	052456	Fuse, 6A 600V Class CC Delay
F9 - F10	052512	Fuse Block, 2P Class CC 30A Ind. DIN
	E22716	Fuse, 2A 600V Class CC
HM1	015401	Hour Meter, 12 Volt DC
M1	025698	Motor, 15HP 2230V
M2	025696	Motor, 1/15HP 57RPM 230V 3PH 30:1 Gear
M3	025702	Motor, 1/6HP 90RPM 230V 3PH 19:1 Gear
PB1 - PB2	024945	Switch Head, Red Push Button 22mm XB4
	025161	Switch Body, 22mm 1NC ZB4
PBL1	024974-3	Switch, Green Push Button 22mm 1NO/1NC LED
PBL2 - PBL3	051746	Switch Operator, 2 Button w/Pilot Red/Green
	052501	Boot, Clear Sealing ZB Switch
	025236-31	Switch Body, 22mm Green LED 1NO 24V ZB4
	050540	Contact, NC ZBE102
POT1	025200	Potentiometer Assembly, 4-20mA 24V w/Conn.
	033476	O-Ring, 7/32" ID #009 (2 required)
	033478	Knob, 1/4" ID Fluted Round Plastic
SS1	051744	Switch Operator, 3 Position Momentary Select
	050545	Switch Base, 2NO Contact
	P06257	Knob, Speed Control
PWR1	069703	Power Supply, 24VDC 5A 110/230V
Q1	050881-1	Disconnect, 63Amp 600V 3P 6mm
	050907-1	Operator, Red/Yellow Pistol Grip 6mm
	050908-1	Shaft, Pistol Grip Disconnect 290mm x 6mm
R1	024890	Relay, Control 9A 3P 24VDC Coil
TS1.1 - TS1.2 TS4.1	068105	Terminal Block, 4 Position Grounding
TS1.3 - TS1.6 TS4.2 - TS4.4	068103	Terminal Block, 4 Position Common
TS2.1 - TS2.2	068100	Terminal Block, 2 Position

HR130EC15

Component List		
Item	Wood-Mizer Part No.	Description
C1	051322	Contact, 25A 3P 24VDC Coil Compact
DB1	069701	Distribution Block, 3P 1 to 4
	069728	Cover, Distribution Block
DRV1	069799	Drive Assembly, HR130 Up/Down (Drive+Software)
DRV2	069800	Drive Assembly, HR130 Feed (Drive+Software)
F1 - F3	053717	Fuseholder, Cube 60A
	069702	Fuse, 40A Class J Cube
F4 - F6	053736	Fuseholder, Cube 30A
	053737	Fuse, 30A Class J Cube
F7 - F8	052512	Fuseholder, 2P Class CC Finger Safe
	052456	Fuse, 6A 600V Class CC Delay
F9 - F10	052512	Fuse Block, 2P Class CC 30A Ind. DIN
	E22716	Fuse, 2A 600V Class CC
F11 - F12	052512	Fuseholder, 2P Class CC Finger Safe
	051957	Fuse, 10A 600V Class CC Delay
HM1	015401	Hour Meter, 12 Volt DC
M1	025698	Motor, 15HP 2230V
M2	025696	Motor, 1/15HP 57RPM 230V 3PH 30:1 Gear
M3	025702	Motor, 1/6HP 90RPM 230V 3PH 19:1 Gear
PB1 - PB2	024945	Switch Head, Red Push Button 22mm XB4
	025161	Switch Body, 22mm 1NC ZB4
PBL1	024974-3	Switch, Green Push Button 22mm 1NO/1NC LED
PBL2 - PBL3	051746	Switch Operator, 2 Button w/Pilot Red/Green
	052501	Boot, Clear Sealing ZB Switch
	025236-31	Switch Body, 22mm Green LED 1NO 24V ZB4
	050540	Contact, NC ZBE102
POT1	025200	Potentiometer Assembly, 4-20mA 24V w/Conn.
	033476	O-Ring, 7/32" ID #009 (2 required)
	033478	Knob, 1/4" ID Fluted Round Plastic
SS1	051744	Switch Operator, 3 Position Momentary Select
	050545	Switch Base, 2NO Contact
	P06257	Knob, Speed Control
PWR1	069703	Power Supply, 24VDC 5A 110/230V
Q1	050881-1	Disconnect, 63Amp 600V 3P 6mm
	050907-1	Operator, Red/Yellow Pistol Grip 6mm
	050908-1	Shaft, Pistol Grip Disconnect 290mm x 6mm
R1	024890	Relay, Control 9A 3P 24VDC Coil
T1	069705	Transformer, 240x480 Pri/120x240 Sec 2kA Sealed
TS1.1 - TS1.2 TS4.1	068105	Terminal Block, 4 Position Grounding
TS1.3 - TS1.6 TS3.1 - TS3.2 TS4.2 - TS4.4	068103	Terminal Block, 4 Position Common
TS2.1 - TS2.2	068100	Terminal Block, 2 Position