

**Wood-Mizer® HR120 HR130
Resaw
Parts Manual**

**HR120
HR130**

**Rev. A1.00 - A4.08
Rev. A1.00 - A6.04**

Safety is our #1 concern!

Form #1628



WARNING! Read and understand this manual before using this machine.

California
Proposition 65 Warning



WARNING: Breathing gas/diesel engine exhaust exposes you to chemicals known to the State of California to cause cancer and birth defects or other reproductive harm.

Always start and operate the engine in a well-ventilated area.
If in an enclosed area, vent the exhaust to the outside.
Do not modify or tamper with the exhaust system.
Do not idle the engine except as necessary.

For more information go to **www.P65warnings.ca.gov**.



WARNING: Drilling, sawing, sanding or machining wood products can expose you to wood dust, a substance known to the State of California to cause cancer. Avoid inhaling wood dust or use a dust mask or other safeguards for personal protection.

For more information go to **www.P65Warnings.ca.gov/wood**.

Active Patents assigned to Wood-Mizer, LLC

Wood-Mizer, LLC has received patents that protect our inventions which are a result of a dedication to research, innovation, development, and design. Learn more at: woodmizer.com/patents

©2024 Wood-Mizer LLC

Printed in the United States of America, all rights reserved. No part of this manual may be reproduced in any form by any photographic, electronic, mechanical or other means or used in any information storage and retrieval system without written permission from

Wood-Mizer, LLC
8180 West 10th Street
Indianapolis, Indiana 46214

Table of Contents

Section-Page

SECTION 1	REPLACEMENT PARTS	1-1
1.1	How To Use The Parts List.....	1-1
1.2	Sample Assembly.....	1-1
1.3	Torque Values	1-2
SECTION 2	BLADE GUIDE ROLLERS & ARM	2-1
2.1	Blade Guide Assembly, Idle Side	2-1
2.2	Blade Guide Assembly, Drive Side	2-3
2.3	Blade Guide Arm	2-5
SECTION 3	BLADE WHEELS & TENSIONER	3-1
3.1	Blade Drive Assembly	3-1
3.2	Idle Blade Wheel Assembly.....	3-2
3.3	Blade Tensioner Assembly	3-3
3.4	Blade Tensioner Assembly	3-4
SECTION 4	SAW HEAD ASSEMBLIES	4-1
4.1	Blade Housing Covers & Wood Blocks	4-1
4.2	Water Lube Assembly (G18/G25, G15 & D17)	4-3
4.3	Water Lube Assembly (G18/G25)	4-5
4.4	Water Lube Assembly (D17)	4-7
4.5	Saw Head Decals	4-9
4.6	Saw Head Decals	4-11
4.7	Saw Head Decals	4-13
SECTION 4	CONTROL & BATTERY BOXES	4-1
4.1	Battery Box Assembly	4-1
4.2	Feed Control Box Assembly (HR120G15/G18/G25).....	4-2
4.3	Feed Control Box Assembly (HR120D17).....	4-4
4.4	Feed Control Box Assembly (HR120E10)	4-5
4.5	Up/Down Control Box Assembly (G15/G18/G25)	4-6
4.6	Up/Down Control Box Assembly (D17)	4-9
4.7	Up/Down Control Box Assembly (HR120E10/HR120EA10)	4-11
4.8	Control Panel Components (HR120EA10).....	4-13
4.9	Control Assembly (HR130EB15)	4-14
4.10	Control Assembly (HR130EB15)	4-16
4.11	Control Assembly (HR130EC15)	4-18
4.12	Operator Control Assembly (HR130).....	4-20
4.13	Control Insert Components (HR120E10/HR120EA10)	4-23
4.14	Control Insert Components (HR120E10)	4-25
4.15	Control Insert Components (HR130EB15).....	4-27
4.16	Control Insert Components (HR130EC15).....	4-29
SECTION 5	UP/DOWN SYSTEM	5-1
5.1	Saw Head Lift (HR120)	5-1
5.2	Saw Head Lift (HR120)	5-3
5.3	Saw Head Lift (HR130)	5-5
5.4	Saw Head Mount & Blade Height Scale.....	5-7

Table of Contents

Section-Page

SECTION 6	CONVEYOR BELT FEED SYSTEM	6-1
6.1	Feed Belt Conveyor (HR120).....	6-1
6.2	Feed Belt Conveyor (HR120).....	6-3
6.3	Feed Belt Conveyor (HR120).....	6-4
6.4	Feed Belt Conveyor (HR130).....	6-6
6.5	Hold-Down Assembly.....	6-7
6.6	Conveyor Feed Assembly (HR120).....	6-8
6.7	Conveyor Feed Assembly (HR120).....	6-10
6.8	Conveyor Drive Assembly (HR130).....	6-11
6.9	Shingle Belt Assembly (Optional).....	6-12
SECTION 7	ENGINE ASSEMBLY	7-1
7.1	Engine (G19).....	7-1
7.2	Engine (G25).....	7-3
7.3	Engine (D17).....	7-5
7.4	Motor (E15).....	7-7
7.5	Motor (E10).....	7-9
7.6	Fuel Tank (G25).....	7-10
7.7	Fuel Tank (G25).....	7-11
7.8	Fuel Tank (G25).....	7-12
7.9	Fuel Tank (D17).....	7-13
7.10	Fuel Tank (D17).....	7-14
7.11	Throttle/Clutch Assembly (G15).....	7-15
7.12	Throttle/Clutch Assembly (G18/G25).....	7-17
7.13	Throttle/Clutch Assembly (D17).....	7-19
7.14	Throttle/Clutch Assembly (E10/E15).....	7-21
SECTION 8	TABLE OPTION	8-1
8.1	HR100 Series Tables.....	8-1

SECTION 1 REPLACEMENT PARTS

1.1 How To Use The Parts List

- Use the table of contents to locate the assembly that contains the part you need.
- Go to the appropriate section and locate the part in the illustration.
- Use the number pointing to the part to locate the correct part number and description in the table.
- Parts shown indented under another part are included with that part.

To Order Parts

- From the continental US, call **1-800-525-8100** to order parts. Have your customer number, vehicle identification number, and part numbers ready when you call.
- From other international locations, contact the Wood-Mizer distributor in your area for parts.

1.2 Sample Assembly

REF	PART #	DESCRIPTION	COMMENTS	QTY.
	012345	SAMPLE ASSEMBLY, COMPLETE	INCLUDES ITEMS 1-6	1
1	F02222-22	Sample Part		1
2	F03333-33	Sample Part		2
	098765	Sample Subassembly	Includes items 3-6	1
3	S04444-44	Subassembly Sample Part		1
4	K55555	Subassembly Sample Part		1
	054321	Sample Sub-Subassembly	Includes items 5-6	2
5	022222	Sub-Subassembly Sample Part		1
6	F10234-56	Sub-Subassembly Sample Part		1

The Sample Assembly, Complete, part number 02345 (top level assembly) includes two parts (F0222-22 and F0333-33) and the 098765 subassembly.

Subassembly 098765 contains two parts(S04444-44 and K55555) and two copies of sub-subassembly 054321.

Each sub-subassembly 054321 contains two parts (022222 and F10234-56).

1.3 Torque Values

Grade		Units	SAE 5	SAE 8
Grade Mark				
Bolt Dia.	Threads Per In.	Units	SAE 5	SAE 8
6	32	in-lbs (Nm)	20 (2.3)	-
8	32	in-lbs (Nm)	24 (2.7)	30 (3.4)
10	24	in-lbs (Nm)	35 (4.0)	45 (5.1)
10	32	in-lbs (Nm)	40 (4.5)	50 (5.7)
12	24	in-lbs (Nm)	50 (5.7)	65 (7.3)
1/4	20	in-lbs (Nm)	95 (10.7)	125 (14.1)
1/4	28	in-lbs (Nm)	95 (10.7)	150 (17.0)
5/16	18	ft-lbs (Nm)	17 (22.6)	23 (31.2)
5/16	24	ft-lbs (Nm)	20 (27.1)	25 (33.8)
3/8	16	ft-lbs (Nm)	30 (40.7)	40 (54.2)
3/8	24	ft-lbs (Nm)	35 (47.5)	45 (61.0)
7/16	14	ft-lbs (Nm)	50 (67.8)	65 (88.1)
7/16	20	ft-lbs (Nm)	55 (74.6)	70 (94.9)
1/2	13	ft-lbs (Nm)	75 (101.7)	100 (135.6)
1/2	20	ft-lbs (Nm)	85 (115.3)	110 (149.2)
9/16	12	ft-lbs (Nm)	105 (142.4)	135 (183.1)
9/16	18	ft-lbs (Nm)	115 (155.9)	150 (203.4)
5/8	11	ft-lbs (Nm)	150 (203.4)	195 (264.4)
5/8	18	ft-lbs (Nm)	160 (217.0)	210 (284.8)
3/4	10	ft-lbs (Nm)	170 (230.5)	220 (298.3)
3/4	16	ft-lbs (Nm)	175 (237.3)	225 (305.1)
7/8	9	ft-lbs (Nm)	302 (409.5)	473 (640.9)
7/8	14	ft-lbs (Nm)	300 (406.8)	400 (542.4)
1	8	ft-lbs (Nm)	466 (631.8)	714 (967.4)

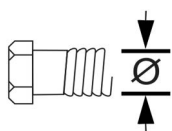

Metric Bolt Head Identification



Metric Grade 8.8



Metric Grade 10.9

COARSE THREAD					FINE THREAD				Wrench Size	
Diameter & Thread Pitch	Metric 8.8		Metric 10.9		Diameter & Thread Pitch	Metric 8.8		Metric 10.9		
	N-m	lbs-ft	N-m	lbs-ft		N-m	lbs-ft	N-m		lbs-ft
6 x 1.0	8	6	11	8					10 mm	
8 x 1.25	20	15	27	20	8 x 1.0	21	16	29	22	13 mm
10 x 1.5	39	29	54	40	10 x 1.25	41	30	57	42	16 mm
12 x 1.75	68	50	94	70	12 x 1.25	75	55	103	76	18 mm
14 x 2.0	109	80	151	111	14 x 1.5	118	87	163	120	21 mm
16 x 2.0	169	125	234	173	16 x 1.5	181	133	250	184	24 mm
18 x 2.5	234	172	323	239	18 x 1.5	263	194	363	268	27 mm
20 x 2.5	330	244	457	337	20 x 1.5	367	270	507	374	30 mm
22 x 2.5	451	332	623	460	22 x 1.5	495	365	684	505	34 mm
24 x 3.0	571	421	790	583	24 x 2.0	623	459	861	635	36 mm
30 x 3.0	1175	867	1626	1199	30 x 2.0	1258	928	1740	1283	46 mm

SECTION 2 BLADE GUIDE ROLLERS & ARM

2.1 Blade Guide Assembly, Idle Side

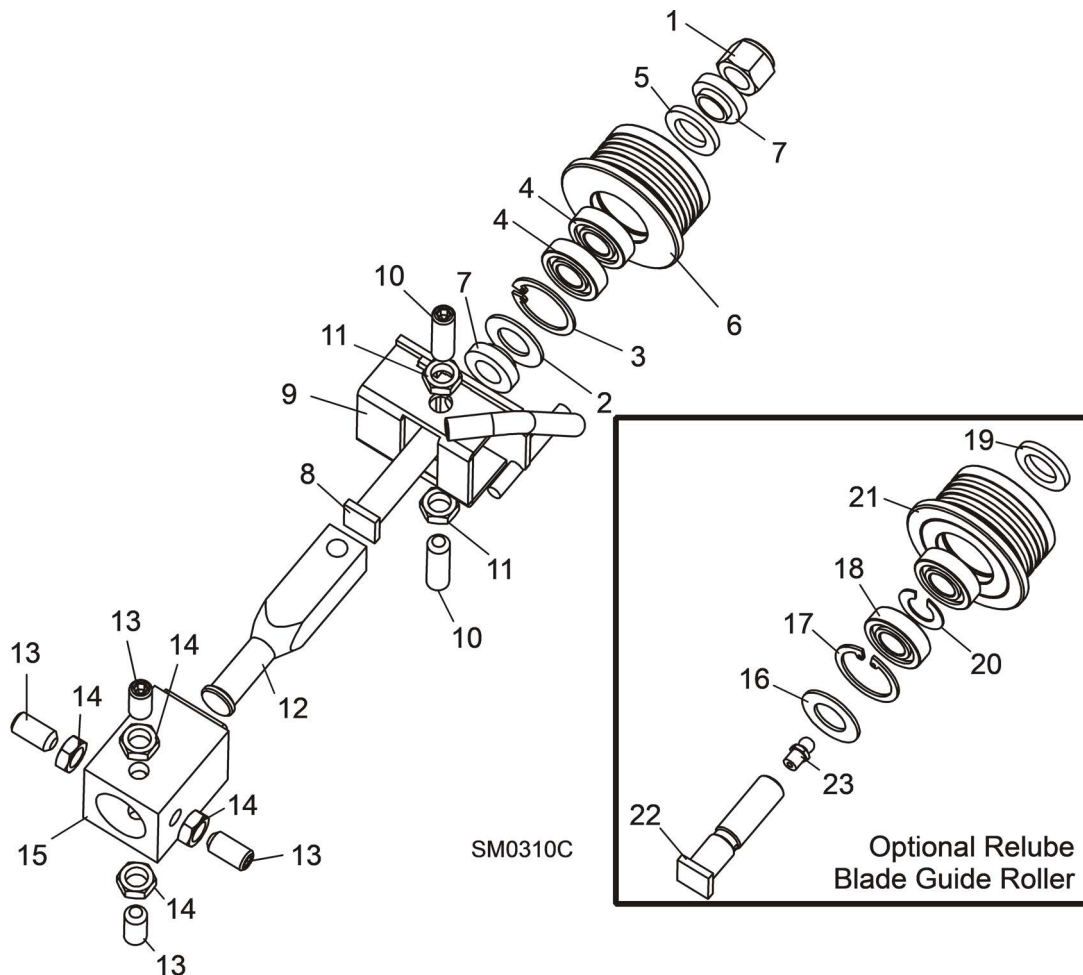

REF	PART #	DESCRIPTION	COMMENTS	QTY.
	A08197	BLADE GUIDE ASSEMBLY, COMPLETE IDLE SIDE		1
1	F05010-15	Nut, 1/2-20 Hex Nylon Lock		1
	A04925	Roller Assembly, Blade Guide	standard	1
	K07079	Bearing Kit, Blade Guide Rebuild		1
2	P04252	Washer, 5/8" White Felt		1
3	F04254-1	Ring, 1 1/8" Interior Retaining		1
4	015975	Bearing, R8-2RS Blade Guide	Available in assemblies only.	2
5	P06455	Washer, 5/8" Gray Felt		1
	F05005-105	Screw, 1/4-28 x 1/4" Socket Head Cup Point Set Black Oxide		1
	057407-1507	Instruction Sheet, Blade Guide Rebuild		1
6	S04250	Roller, Flanged Blade Guide	Available in assemblies only.	1
	A04925-364	Instruction Sheet, Blade Guide Roller Replacement		1

2 Blade Guide Rollers & Arm

Blade Guide Assembly, Idle Side

REF	PART #	DESCRIPTION	COMMENTS	QTY.
7	S04253	Spacer, Blade Guide		2
8	036373	Bolt, Blade Guide Roller		1
9	W08495	Bracket, Blade Guide Idle Side With Water Tube		1
10	F05007-96	Screw, 3/8-24 X 1 1/4" Stainless Steel Socket Head Flat Point		2
11	F05010-22	Nut, 3/8-24 Jam		2
12	S08196	Shaft, Blade Guide Adjustment		1
13	F05007-95	SCREW, 3/8-24 X 3/4" STAINLESS STEEL SOCKET HEAD FLAT POINT		4
14	F05010-22	NUT, 3/8-24 JAM		4
15	W08159	TUBE, BLADE GUIDE MOUNT	<i>(See Section 2.3)</i>	1
	016568	ROLLER ASSEMBLY, BLADE GUIDE RELUBE	Optional	1
	057407	Bearing Kit, Relube Blade Guide Rebuild		1
16	P04252	Washer, 5/8" White Felt		1
17	F04254-1	Ring, 1 1/8" Interior Retaining		1
18	015975	Bearing, R8-2RS Blade Guide	Available in assemblies only. Bearing must be modified for use with relube roller assemblies. Remove one seal from each bearing, place open sides facing each other and place spacer 035411 between bearings.	2
19	P06455	Washer, 5/8" Gray Felt		1
	057407-1507	Instruction Sheet, Blade Guide Rebuild		1
20	035411	Spacer, Blade Guide Bearing		1
21	035426	Roller, Flanged Blade Guide Relube	Available in assemblies only.	1
	A04925-364	Instruction Sheet, Blade Guide Roller Replacement		1
22	S08192	BOLT, BLADE GUIDE ROLLER	Relube only	1
23	P05060	FITTING, 1/4-28 GREASE	Relube only	1

2.2 Blade Guide Assembly, Drive Side

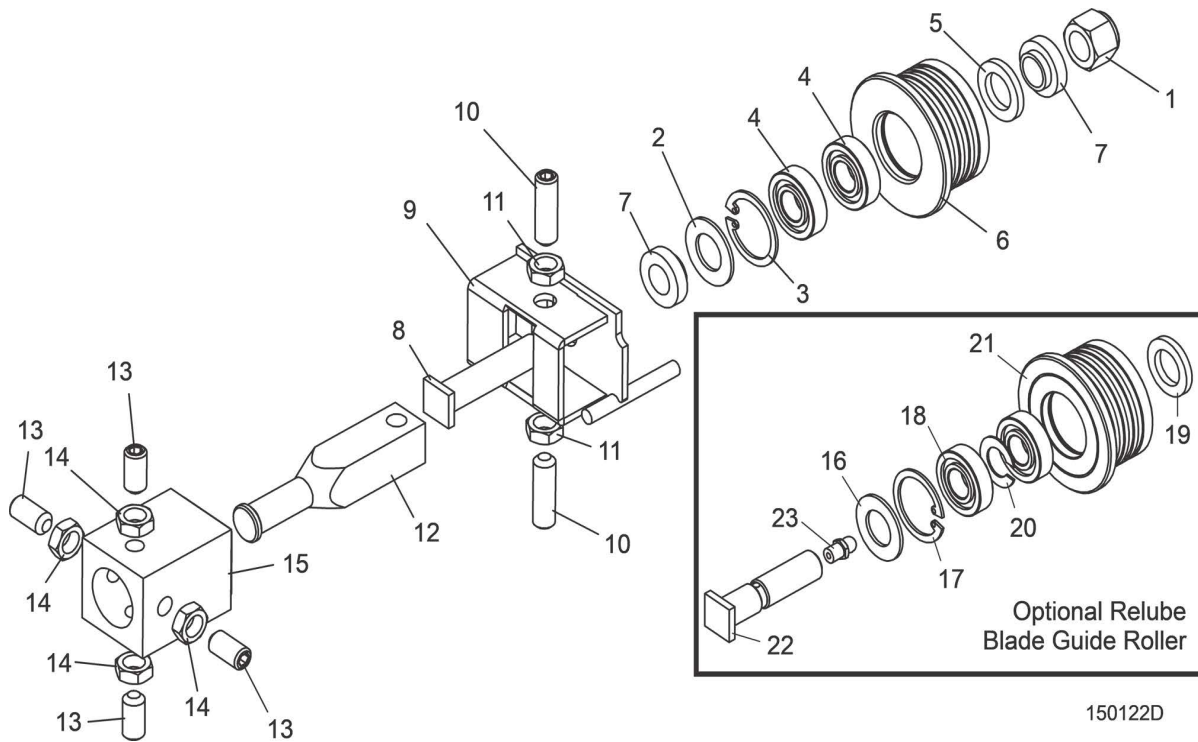

REF	PART #	DESCRIPTION	COMMENTS	QTY.
	A08191	BLADE GUIDE ASSEMBLY, COMPLETE DRIVE SIDE		1
1	F05010-15	Nut, 1/2-20 Hex Nylon Lock		1
	A04925	Roller Assembly, Blade Guide	Standard	1
	K07079	Bearing Kit, Blade Guide Rebuild		1
2	P04252	Washer, 5/8" White Felt		1
3	F04254-1	Ring, 1 1/8" Interior Retaining		1
4	015975	Bearing, R8-2RS Blade Guide	Available in assemblies only.	2
5	P06455	Washer, 5/8" Gray Felt		1
	F05005-105	Screw, 1/4-28 x 1/4" Socket Head Cup Point Set Black Oxide		1
	057407-1507	Instruction Sheet, Blade Guide Rebuild		1
6	S04250	Roller, Flanged Blade Guide	Available in assemblies only.	1
	A04925-364	Instruction Sheet, Blade Guide Roller Replacement		1
7	S04253	Spacer, Blade Guide		2
8	036373	Bolt, Blade Guide Roller		1
9	W08482	Bracket, Blade Guide Drive Side		1
10	F05007-96	Screw, 3/8-24 X 1 1/4" Stainless Steel Socket Head Flat Point		2
11	F05010-22	Nut, 3/8-24 Jam		2
12	S08196	Shaft, Blade Guide Adjustment		1
13	F05007-95	SCREW, 3/8-24 X 3/4" STAINLESS STEEL SOCKET HEAD FLAT POINT SET		3

2 Blade Guide Rollers & Arm

Blade Guide Assembly, Drive Side

REF	PART #	DESCRIPTION	COMMENTS	QTY.
14	F05007-99	BOLT, 3/8-24 X 1" STAINLESS STEEL HEX HEAD		1
15	F05010-22	NUT, 3/8-24 JAM		4
16	W08159	TUBE WELDMENT, BLADE GUIDE MOUNT	Part of saw frame weldment	1
	016568	ROLLER ASSEMBLY, BLADE GUIDE RELUBE	Optional	1
	057407	Bearing Kit, Relube Blade Guide Rebuild		1
17	P04252	Washer, 5/8" White Felt		1
18	F04254-1	Ring, 1 1/8" Interior Retaining		1
19	015975	Bearing, R8-2RS Blade Guide	Available in assemblies only. Bearing must be modified for use with relube roller assemblies. Remove one seal from each bearing, place open sides facing each other and place spacer 035411 between bearings.	2
20	P06455	Washer, 5/8" Gray Felt		1
21	035411	Spacer, Blade Guide Bearing		1
	057407-1507	Instruction Sheet, Blade Guide Rebuild		1
22	035426	Roller, Flanged Blade Guide Relube	Available in assemblies only.	1
	A04925-364	Instruction Sheet, Blade Guide Roller Replacement		1
23	S08192	BOLT, BLADE GUIDE ROLLER	Relube only	1
24	P05060	FITTING, 1/4-28 GREASE	Relube only	1

2.3 Blade Guide Arm

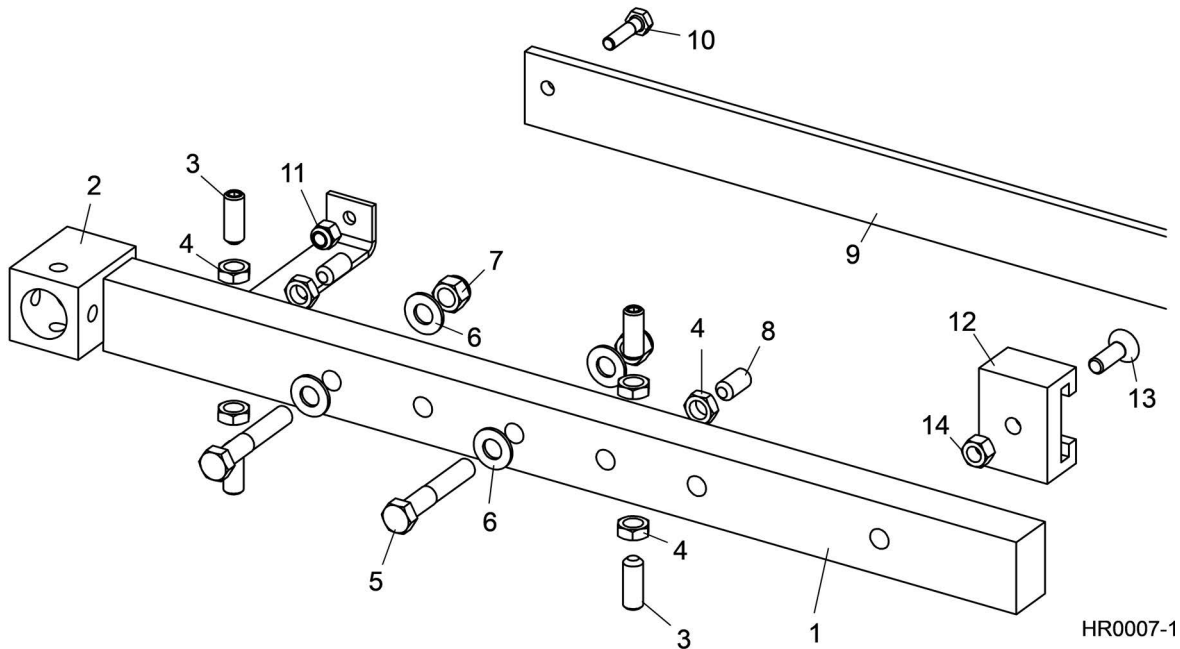

REF	PART #	DESCRIPTION	COMMENTS	QTY.
1	063127	BAR WLDMNT, BLADE GUIDE		1
2	W08159	Tube, Blade Guide Mount		1
3	F05007-184	SCREW, 3/8-24 X 1" FLAT POINT SOCKET HEAD STAINLESS		4
4	F05010-22	NUT, 3/8"-24 HEX JAM		6
5	F05007-201	BOLT, 3/8-16 X 2 1/4" HEX HEAD GRADE 5		2
6	F05011-3	WASHER, 3/8" SAE FLAT		4
7	F05010-10	NUT, 3/8-16 HEX NYLON LOCK		2
8	F05007-95	SCREW, 3/8-24 X 3/4" FLAT POINT SOCKET HEAD STAINLESS		2
9	063194	GUARD, LT15 BLADE GUIDE ARM		1
10	F05005-38	BOLT, 1/4-20 X 1" HEX HEAD GRADE 2		1
11	F05010-69	NUT, 1/4-20 HEX NYLON LOCK		1
12	014882	BLOCK, BLADE GUIDE ARM GUARD GUIDE		1
13	F05006-124	BOLT, 5/16-18 X 1" FLAT HEAD		1
14	F05010-6	NUT, 5/16-18 HEX LOCK		1

SECTION 3 BLADE WHEELS & TENSIONER

3.1 Blade Drive Assembly

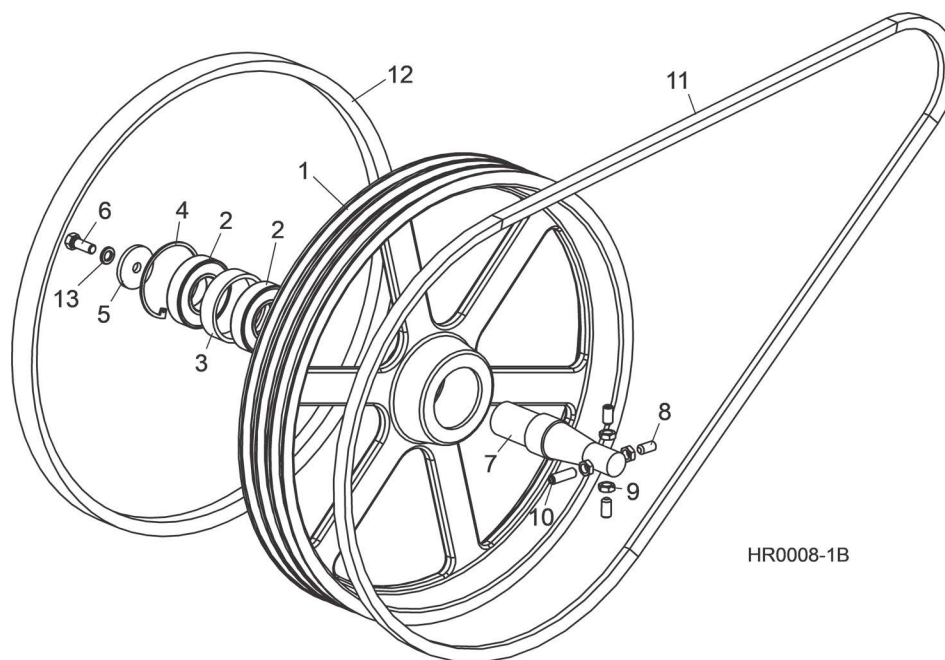

REF	PART #	DESCRIPTION	COMMENTS	QTY.
	014995	WHEEL ASSEMBLY, DRIVE SIDE BLADE (G15/E10/E15)		1
	036657	WHEEL ASSEMBLY, DRIVE SIDE BLADE (G18/G25/D17)		1
1	014727	Wheel, Drive Side Blade (G15/E10/E15)		1
	047702	Wheel, Drive Side Blade (G18/G25/D17)		1
2	014811	Bearing, #6207 2RS		2
3	014730	Spacer, Drive Bearing		1
4	F04254-30	Ring, 3.121 IR Beveled Retaining		1
5	014728	WASHER, DRIVE WHEEL RETAINING		1
6	F05007-87	BOLT, 3/8-16 X 1" HEX HEAD GRADE 5		1
7	014729	SHAFT, LT15 DRIVE SIDE BLADE WHEEL		1
8	F05007-95	SCREW, 3/8-24 X 3/4" FLAT POINT SOCKET HEAD STAINLESS		3
9	F05010-22	NUT, 3/8-24 HEX JAM		4
10	F05007-96	SCREW, 3/8-24 X 1 1/4" FLAT POINT SOCKET HEAD STAINLESS		1
11	P25301	BELT, BX85 (60HZ E10/E15)		1
	P20701	BELT, BX86 (50HZ E15)		1
	047751	BELT, 2/3VFL900 DRIVE (G18/G25/D17)		1
	017943	BELT, BX87 (G15)		1
12	P04185	BELT, B57		1
13	F05011-4	WASHER, 3/8" SPLIT LOCK		1

3.2 Idle Blade Wheel Assembly

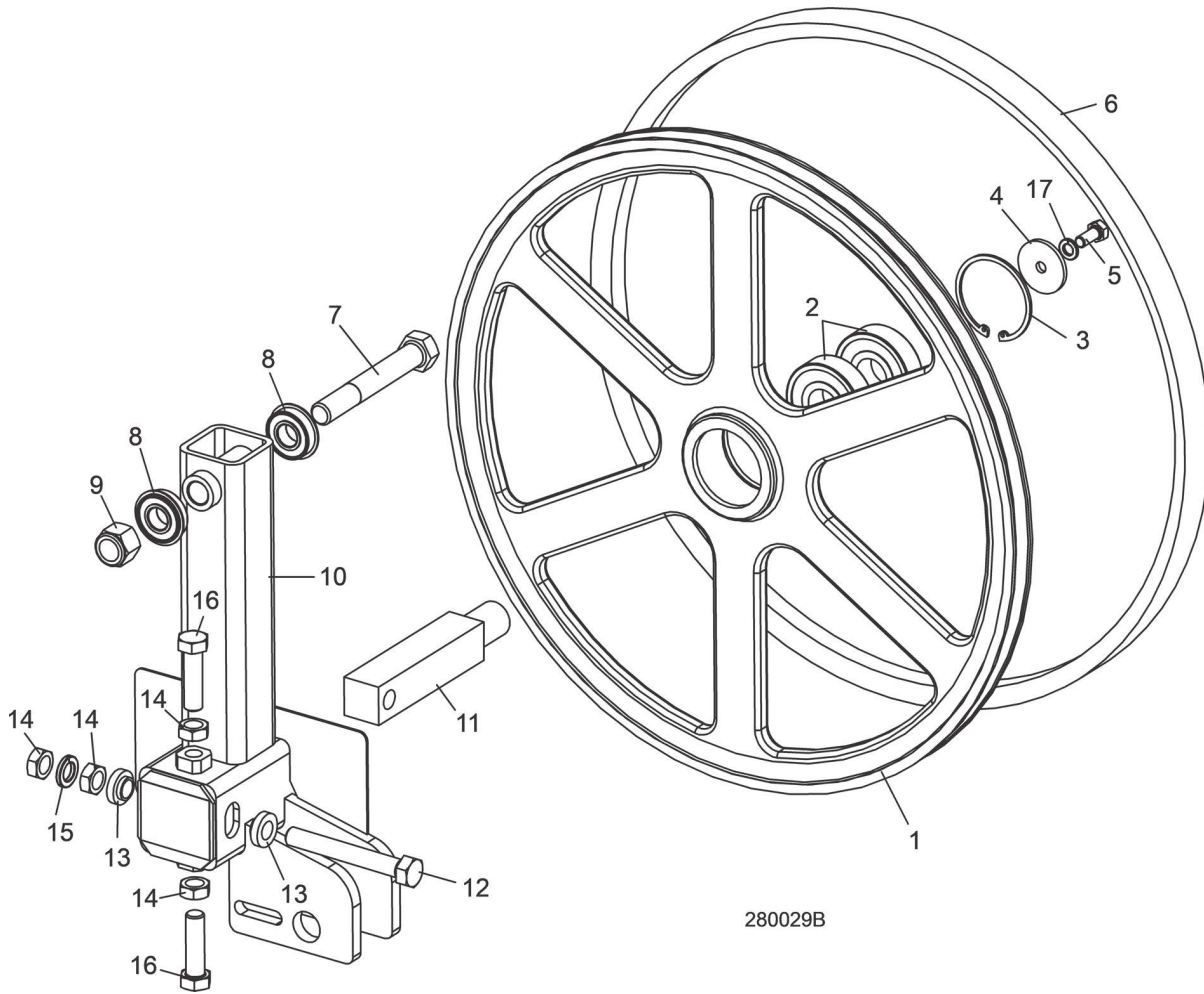

REF	PART #	DESCRIPTION	COMMENTS	QTY.
	A08218	WHEEL ASSEMBLY, IDLE SIDE BLADE		1
1	P08125	Wheel, Idle Side Blade	Available in assemblies only.	1
2	P08066	Bearing, Idle Side Blade Wheel #6305-AA, C3, ABEC-1, SRI-2 Grease		2
3	F04254-21	Ring, 2 7/16" Internal Retaining		1
4	S08220	WASHER, IDLE BLADE WHEEL RETAINER		1
5	F05006-102	BOLT, 5/16-18 X 3/4" HEX HEAD		1
6	P04185	BELT, BLADE WHEEL B57		1
7	F05009-3	BOLT, 5/8-11 X 4 1/2" HEX HEAD		1
8	014834	BEARING, 5/8" I.D. W/SNAP RING		2
9	F05010-34	NUT, 5/8-11 HEX NYLON LOCK		1
10	049349	IDLER WELDMENT, BLADE WHEEL		1
11	S12565	SHAFT, IDLE WHEEL		1
12	F05008-111	BOLT, 1/2-20 X 3 3/4" HEX HEAD FULL THREAD GRADE 2		1
13	S04253	SPACER, 1/2" I.D. FLANGED		2
14	F05010-16	NUT, 1/2-20 HEX JAM		4
15	F05011-9	WASHER, 1/2" SPLIT LOCK		1
16	F05008-127	BOLT, 1/2-20 X 1 3/4" HEX HEAD GRADE 5		2

3.3 Blade Tensioner Assembly

HR120Rev. A4.04+

HR130Rev. A4.04+

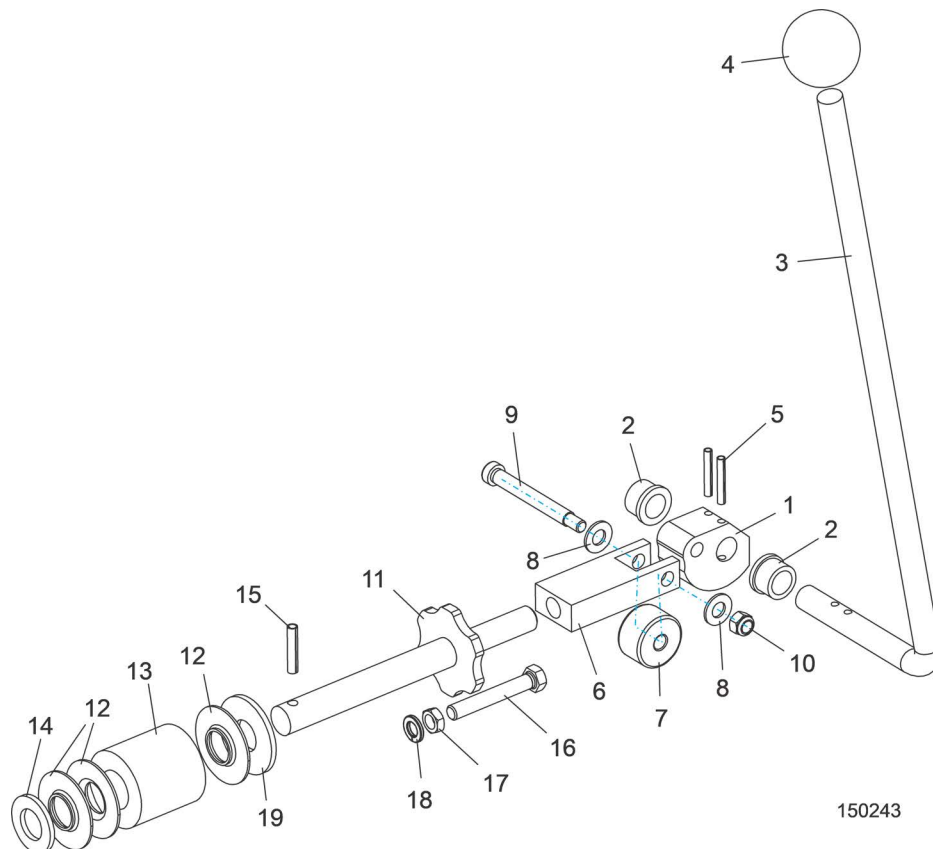

REF	PART #	DESCRIPTION	COMMENTS	QTY.
	074801	TENSION ASSEMBLY, CAM ACTUATED BLADE	LT15/28/35, HR120/130	1
1	049104	Cam, Tension		1
2	P05135	Bushing, 5/8" x 7/8" x 1/2" Bronze		2
3	103801	Handle, Blade Tensioner, LT15/28/35		1
4	P04211	Knob, 5/8-18 Ball		1
5	F05012-16	Pin, 3/16" x 1 1/4" Roll		2
6	049321	Block, Tensioner Bearing Mount		1
7	048219	Cam Follower, 3/8" x 1 3/8" x 13/16"		1
8	F05011-3	Washer, 3/8" SAE Flat		2
9	F05007-202	Bolt, 3/8 x 2 1/2" Socket Head Shoulder		1
10	F05010-58	Nut, 5/16-18 Hex Nylon Lock		1
11	038642	Shaft Weldment, Blade Tension		1
12	014925	Guide, Tension Handle		3
13	014828	Spring, Rubber Tensioner Blade		1
14	F05011-62	Washer, 3/4" SAE Flat		1
15	F05012-12	Pin, 1/4" x 1 1/4" Roll		1
16	F05007-157	Bolt, 3/8-16 x 2 1/2" Hex Head Full Thread		1
17	F05010-29	Nut, 3/8-16 Jam		1
18	F05011-4	Washer, 3/8" Split Lock		1
19	F05011-29	Washer, 3/4" USS Flat		1

3.4 Blade Tensioner Assembly

HR120Rev. A1.00 - A4.03

HR130Rev. A1.00 - A4.03

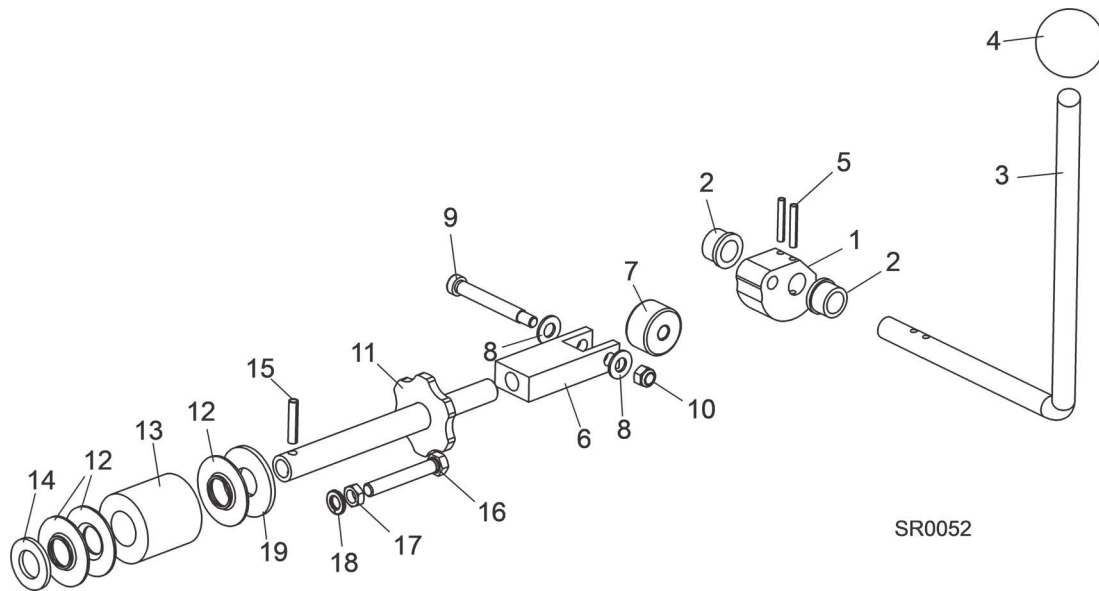

REF	PART #	DESCRIPTION	COMMENTS	QTY.
	038643	TENSION ASSEMBLY, CAM ACTUATED BLADE		1
1	049104	Cam, Tension		1
2	P05135	Bushing, 5/8" x 7/8" x 1/2" Bronze		2
3	048804	Handle, Blade Tensioner		1
4	P04211	Knob, 5/8-18 Ball		1
5	F05012-16	Pin, 3/16" x 1 1/4" Roll		2
6	049321	Block, Tensioner Bearing Mount		1
7	048219	Cam Follower, 3/8" x 1 3/8" x 13/16"		1
8	F05011-3	Washer, 3/8" SAE Flat		2
9	F05007-202	Bolt, 3/8 x 2 1/2" Socket Head Shoulder		1
10	F05010-58	Nut, 5/16-18 Hex Nylon Lock		1
11	038642	Shaft Weldment, Blade Tension		1
12	014925	Guide, Tension Handle		3
13	014828	Spring, Rubber Tensioner Blade		1
14	F05011-62	Washer, 3/4" SAE Flat		1
15	F05012-12	Pin, 1/4" x 1 1/4" Roll		1
16	F05007-157	Bolt, 3/8-16 x 2 1/2" Hex Head Full Thread		1
17	F05010-29	Nut, 3/8-16 Jam		1
18	F05011-4	Washer, 3/8" Split Lock		1
19	F05011-29	Washer, 3/4" USS Flat		1

SECTION 4 SAW HEAD ASSEMBLIES

4.1 Blade Housing Covers & Wood Blocks

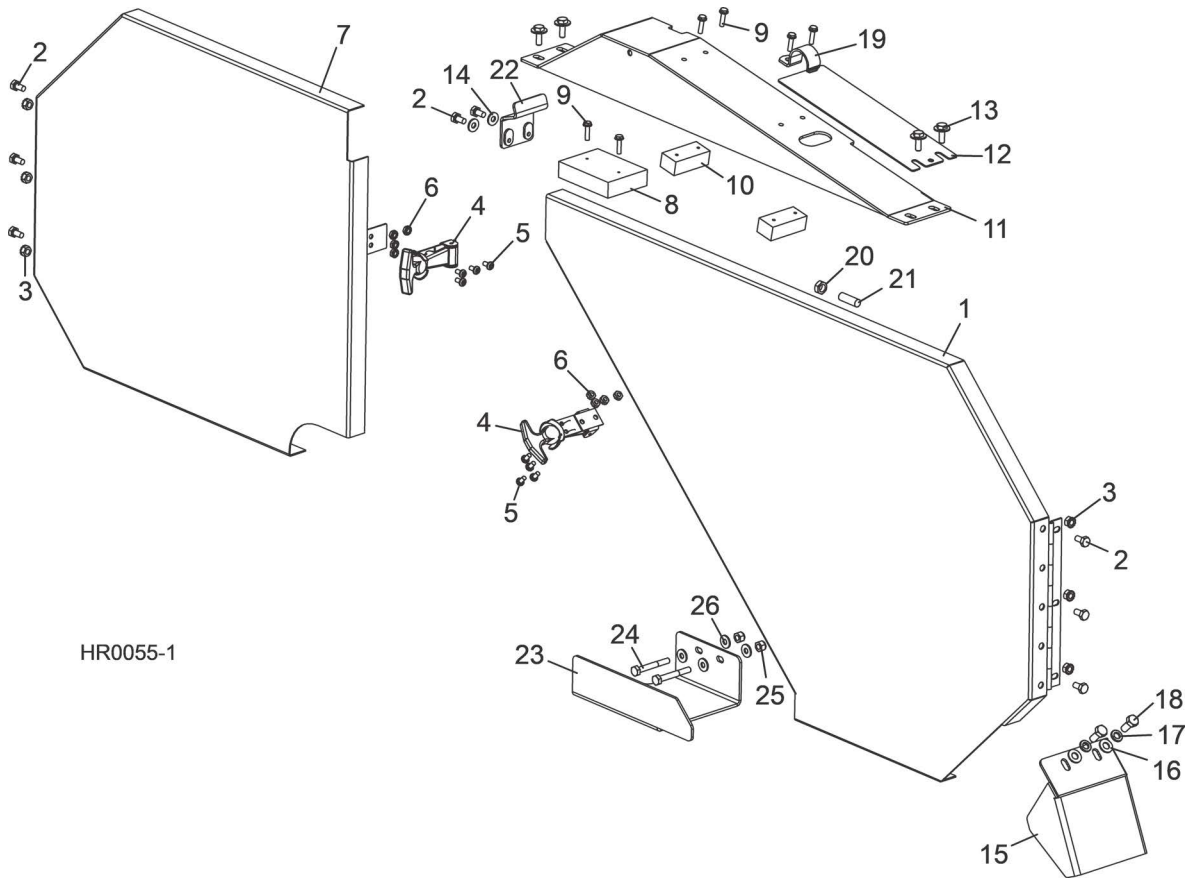

REF	PART #	DESCRIPTION	COMMENTS	QTY.
1	065072	COVER, DRIVE SIDE HR120 BLADE HOUSING	Replaces 014984 originally supplied prior to 11/15/10. Logo decals modified and no longer appropriate for HR100 series resaws. INCLUDES COVER DECALS - (See Section 4.5)	1
	065317	COVER, DRIVE SIDE HR130 BLADE HOUSING	INCLUDES COVER DECALS - (See Section 4.5)	1
2	F05005-15	BOLT, 1/4-20 X 1/2" HEX HEAD		8
3	F05010-9	NUT, 1/4-20 KEPS		6
4	014829	LATCH, FLEXIBLE DRAW		2
5	F05004-3	SCREW, #10-24 X 3/8" CROSS SLOTTED ROUND HEAD		8
6	F05010-14	NUT, #10-24 SELF-LOCKING HEX		8
7	065073	COVER, IDLE SIDE HR120 BLADE HOUSING	Replaces 014985 originally supplied prior to 11/15/10. Logo decals modified and no longer appropriate for HR100 series resaws. INCLUDES COVER DECALS - (See Section 4.5)	1
	065075	COVER, IDLE SIDE HR130 BLADE HOUSING	INCLUDES COVER DECALS - (See Section 4.5)	1
8	015844	BLOCK, BLADE VIBRATION DAMPENING		1

REF	PART #	DESCRIPTION	COMMENTS	QTY.
9	F05015-33	BOLT, #10 X 3/4" SLOTTED HEX WASHER HEAD		6
10	016506	BLOCK, 3/4" X 1" X 2" WOOD	E10/E15 Only.	2
	038633	COVER ASSEMBLY, TOP ENGINE PULLEY	Modified to add belt tension access opening and cover (4/15).	1
11	074574	Cover Weldment, LT15/28 Top Belt Cover		1
12	074546	Plate, Belt Guard Cover		1
13	F05005-134	Bolt, 1/4-20 x 3/4" Hex Head w/Conical Washer		4
14	F05011-11	WASHER, 1/4" SAE FLAT		2
15	003811	PLATE, SAWDUST DEFLECTOR		1
16	F05011-17	WASHER, 5/16" SAE FLAT		2
17	F05011-13	WASHER, 5/16" SPLIT LOCK		2
18	F05006-5	BOLT, 5/16-18 X 3/4" HEX HEAD		2
19	P05436	CLAMP, 1" EMT (E10 ONLY)		1
20	F05010-29	NUT, 3/8-16 JAM		1
21	F05007-18	SCREW, 3/8-16 X 1 1/4 SHOP SET		1
22	074394	BRACKET WELDMENT, LT15 BELT ENHANCE	Belt enhancement bracket added to the saw head (HR120/HR130 Rev. A4.01).	1
	079320	GUARD ASSEMBLY, HR120/130 DRIVE SIDE BLADE	Added 079320 to better guard the blade (HR120 Rev. A4.07/HR130 Rev. A6.02). Order 079398 Drive Side Blade Kit to add to older resaws.	1
23	079319	Plate, HR120/130 Drive Side Blade Guard		1
24	F05005-125	Bolt, 1/4-20x2 Hex Head Grade 5		2
25	F05010-69	Nut, 1/4-20 Nylock		2
26	F05011-11	Washer, 1/4 SAE Flat		4
	015849	Decal, LT15 Blade Guide Bar		0.3

4.2 Water Lube Assembly (G18/G25, G15 & D17)

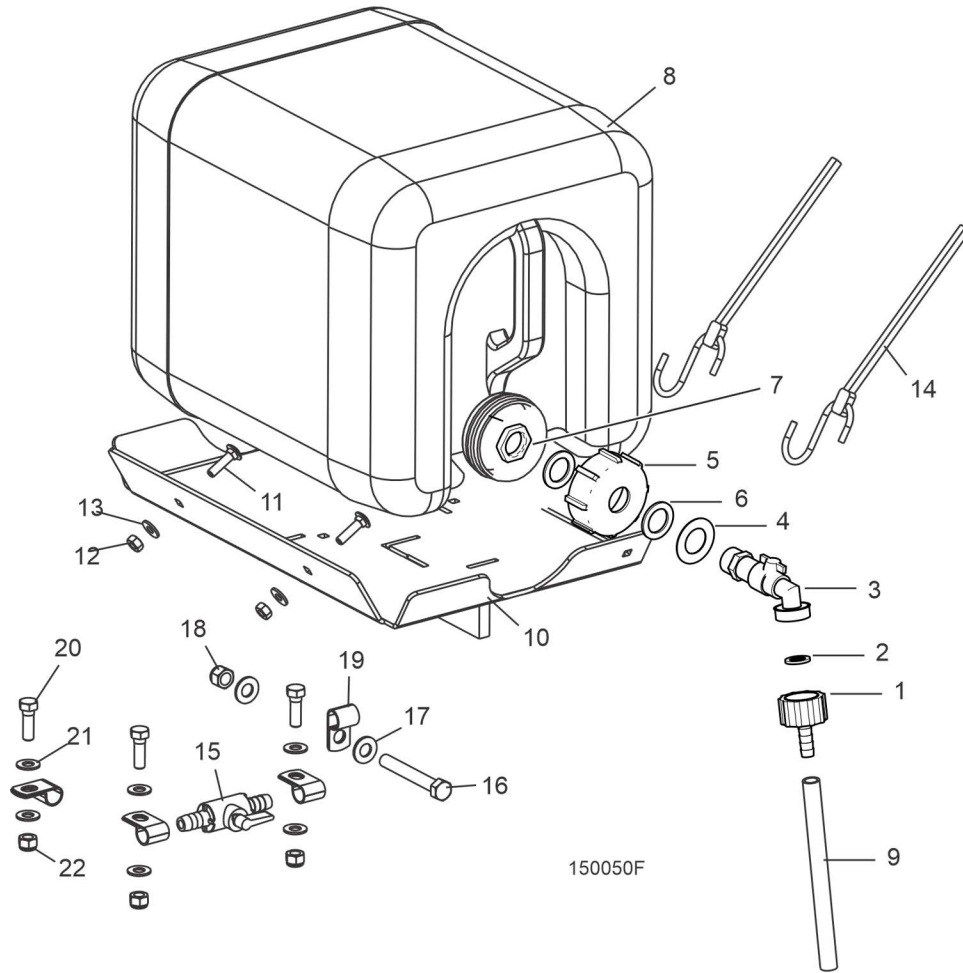

REF	PART #	DESCRIPTION	COMMENTS	QTY.
	015799	WATER LUBE ASSEMBLY		1
	550787	Assembly, Water Bottle	Replaced 014642, 061372, 133320 & 014113 after 1/29/2024 per ECN 39290.	1
1	550777	Fitting, G3/4" X 10mm Hose Barb		1
2	550778	Gasket, 1/2 (Batard)		1
3	550776	Fitting, Water Lube Shutoff Valve		1
4	530841	Shim, 21/37-1		1
5	550785	Cap, Water Bottle		1
6	550780	O-ring, 27x20x1.5		2
7	550779	Gland Nut, 1/2 Npt		1
8	513866	Bottle, Water		1
	014642	Bottle Assembly, Water Lube w/Cap		1
	061372	O-ring, Water Bottle Cap	If the water bottle cap keeps leaking, add this o-ring to the cap. Leave the existing o-ring installed.	1
	014636	Fitting, 3/4FPT x 3/4MPT	Deleted after 9/19/2022 per ECN 38718.	1

REF	PART #	DESCRIPTION	COMMENTS	QTY.
	133320	Valve, 3/4 NPT Elbow 3/4 Male GHT Outlet	Replaced 014100 after 9/19/2022 per ECN 38718.	1
	014100	Fitting, Water Lube Shutoff Valve		1
	014113	Fitting, 5/8" NPT to 3/8" Hose Barb		1
9	R01885	Tubing, Water Lube 3/8" I.D.		7 ft.
10	015798	Tray Weldment, LT15 Water Lube		1
11	F05005-34	Bolt, 1/4-20 x 1" Carriage Head		2
12	F05010-21	Nut, 1/4-20 Hex Lock		2
13	F05011-11	Washer, 1/4" SAE Flat		2
14	P11668	Strap, 20" Rubber w/Hook		2
15	065635	Valve, LT15 Water Shut Off	Added to make the lube system easier to operate (HR120/HR130 Rev. A2.03).	1
16	F05007-27	Bolt, 3/8-16 x 3/4" Hex Head Grade 2		1
17	F05011-4	Washer, 3/8" Split Lock		1
18	F05011-3	Washer, 3/8" Flat SAE		1
19	P07584	Clamp, 1/2" EMT Coated		4
20	F05006-1	Bolt, 5/16-18 x 1" Hex Head		3
21	F05011-17	Washer, 5/16" SAE Flat		6
22	F05010-58	Nut, 5/16-18 Nylok Hex		3

4.3 Water Lube Assembly (G18/G25)

HR120Rev. A1.00 - A4.01

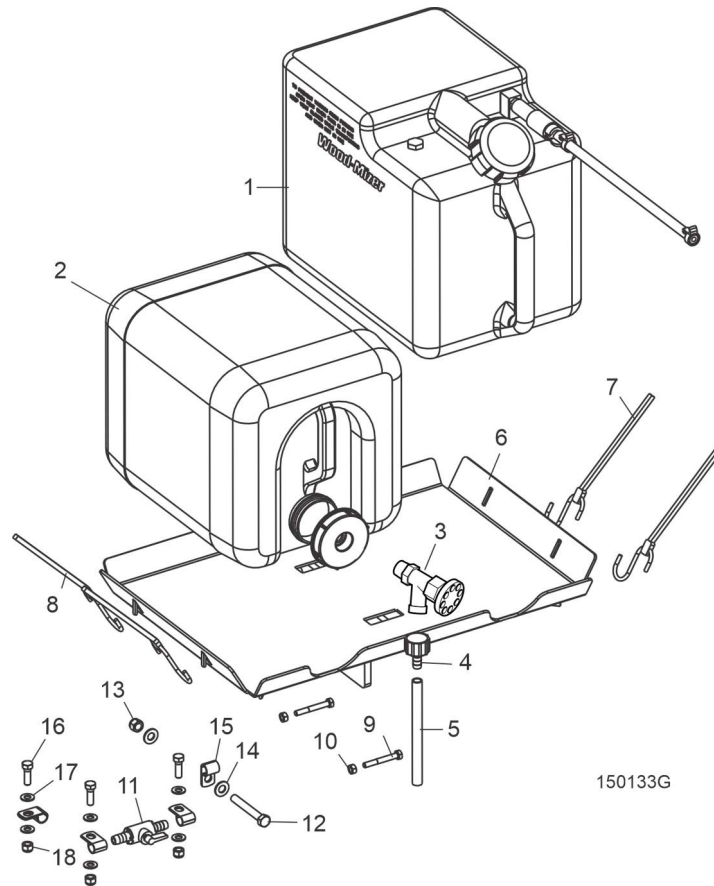

REF	PART #	DESCRIPTION	COMMENTS	QTY.
	047744	WATER LUBE ASSEMBLY		1
1		Fuel Tank Parts (<i>See Section 7.5</i>)		1
2	014642	Bottle Assembly, Water Lube w/Cap		1
	014636	Fitting, 3/4FPT x 3/4MPT	Deleted after 9/19/2022 per ECN 38718	1
3	133320	Valve, 3/4 NPT Elbow 3/4 Male GHT Outlet	Replaced 014100 after 9/19/2022 per ECN 38718.	1
	014100	Fitting, Water Lube Shutoff Valve		1
4	014113	Fitting, 5/8" NPT to 3/8" Hose Barb		1
5	R01885	Tubing, Water Lube 3/8" I.D.		7 ft.
6	047745	Tray Weldment, LT15 Water Lube/Fuel Tank		1
7	P11258	Strap, 24" Rubber w/Hook		2
8	P11668	Strap, 20" Rubber w/Hook		2
9	F05005-125	Bolt, 1/4-20 x 2" Hex Head Grade 5		2
10	F05010-21	Nut, 1/4-20 Hex Lock		2
11	065635	Valve, LT15 Water Shut Off	Added to make the lube system easier to operate (HR120/HR130 Rev. A2.03).	1
12	F05007-27	Bolt, 3/8-16 x 3/4" Hex Head Grade 2		1
13	F05011-4	Washer, 3/8" Split Lock		1

REF	PART #	DESCRIPTION	COMMENTS	QTY.
14	F05011-3	Washer, 3/8" Flat SAE		1
15	P07584	Clamp, 1/2" EMT Coated		4
16	F05006-1	Bolt, 5/16-18 x 1" Hex Head		3
17	F05011-17	Washer, 5/16" SAE Flat		6
18	F05010-58	Nut, 5/16-18 Nylok Hex		3

4.4 Water Lube Assembly (D17)

HR120Rev. A1.00 - A4.04

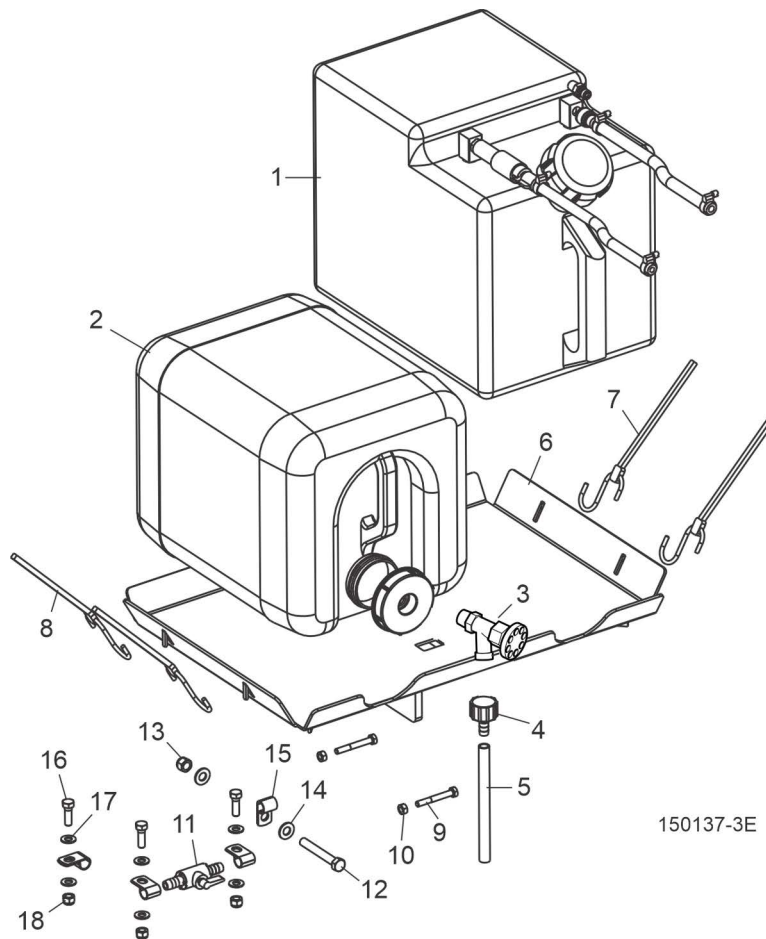

REF	PART #	DESCRIPTION	COMMENTS	QTY.
	038581	TRAY ASSEMBLY, LT15 WATER/DIESEL BOT-TLE		1
1		Fuel Tank Parts (<i>See Section 7.6</i>)		
2	014642	Bottle Assembly, Water Lube w/Cap		1
	014636	Fitting, 3/4FPT x 3/4MPT	Deleted after 9/29/2022 per ECN 38718.	1
3	133320	Valve, 3/4 NPT Elbow 3/4 Male GHT Outlet	Replaced 014100 after 9/29/2022 per ECN 38718.	1
	014100	Fitting, Water Lube Shutoff Valve		1
4	014113	Fitting, 5/8" NPT to 3/8" Hose Barb		1
5	R01885	Tubing, Water Lube 3/8" I.D.		7 ft.
6	047745	Tray Weldment, LT15 Water Lube/Fuel Tank		1
7	P11258	Strap, 24" Rubber w/Hook		2
8	P11668	Strap, 20" Rubber w/Hook		2
9	F05005-125	Bolt, 1/4-20 x 2" Hex Head Grade 5		2
10	F05010-21	Nut, 1/4-20 Hex Lock		2
11	065635	Valve, LT15 Water Shut Off	Added to make the lube system easier to operate (HR120/HR130 Rev. A2.03).	1
12	F05007-27	Bolt, 3/8-16 x 3/4" Hex Head Grade 2		1

REF	PART #	DESCRIPTION	COMMENTS	QTY.
13	F05011-4	Washer, 3/8" Split Lock		1
14	F05011-3	Washer, 3/8" Flat SAE		1
15	P07584	Clamp, 1/2" EMT Coated		4
16	F05006-1	Bolt, 5/16-18 x 1" Hex Head		3
17	F05011-17	Washer, 5/16" SAE Flat		6
18	F05010-58	Nut, 5/16-18 Nylok Hex		3

4.5 Saw Head Decals

After 5/11

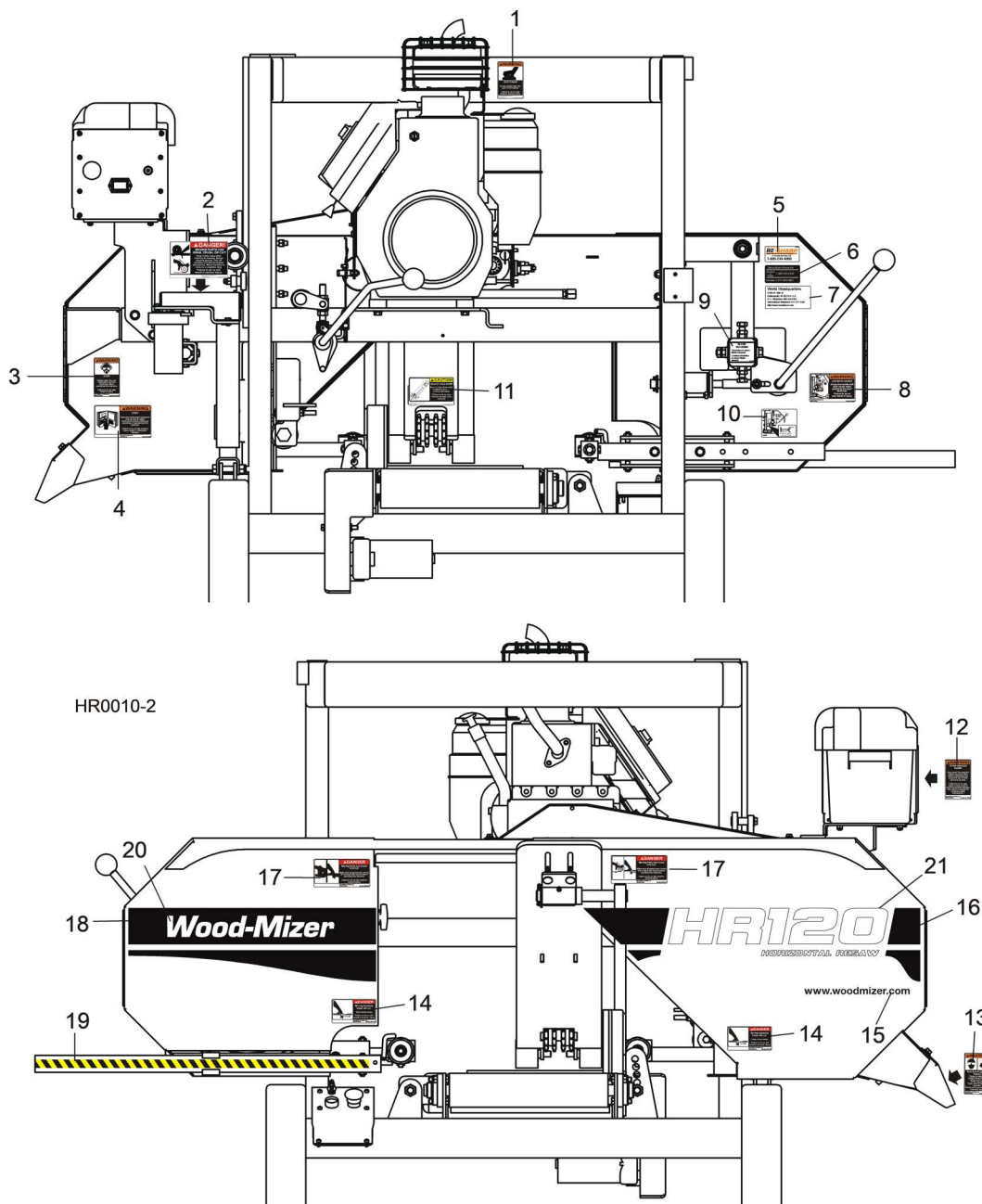

REF	PART #	DESCRIPTION	COMMENTS	QTY.
1	014419	DECAL, HOT ENGINE WARNING		1
2	028720	DECAL, MOVING PARTS DANGER		1
3	S11753	DECAL, EYE/EAR PROTECTION WARNING		1
4	016402	DECAL, READ MANUAL WARNING		1
5	P12879	DECAL, RESHARP INFO		1
6	S12117	DECAL, TOLL FREE PARTS		1
7	015840	DECAL, WORLD HEADQUARTERS ADDRESS		1
8	049367	DECAL, TENSIONER WARNING		1

REF	PART #	DESCRIPTION	COMMENTS	QTY.
9	P11789	DECAL, BLADE TRACK INFO		1
10	049368	DECAL, BLADE TENSION INFO		1
11	063189	DECAL, ADJUST HOLD-DOWN CAUTION		1
12	P10364	DECAL, 12V ELECTRICAL SYSTEM WARNING		1
13	P11754	DECAL, SAWDUST CHUTE WARNING		1
14	S11752	DECAL, BLADE DANGER		2
15	003235	DECAL, WOOD-MIZER WEBSITE LOGO		1
16	065385	DECAL, DRIVE SIDE EURO-STRIPE BK HR120		1
	065386	DECAL, DRIVE SIDE EURO-STRIPE BK HR130		1
17	033254	DECAL, MOVING PARTS DANGER		2
18	065008	DECAL, IDLE SIDE EURO-STRIPE BK 15/28/35		1
19	015849	DECAL, BLADE GUIDE ARM STRIPE		1
20	065002	DECAL, WOOD-MIZER LOGO WHT LT10/15/28/35		1
21	062721	DECAL, HR120 EURO LOGO WHITE		1
	062720	DECAL, HR130 EURO LOGO WHITE		1

4.6 Saw Head Decals
Between 4/10 and 5/11

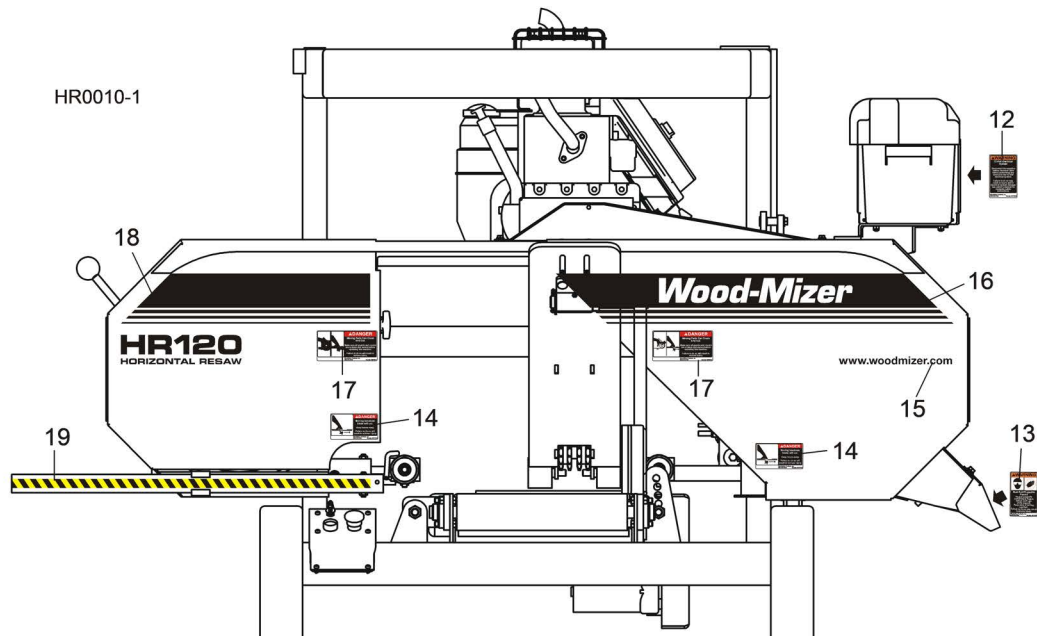
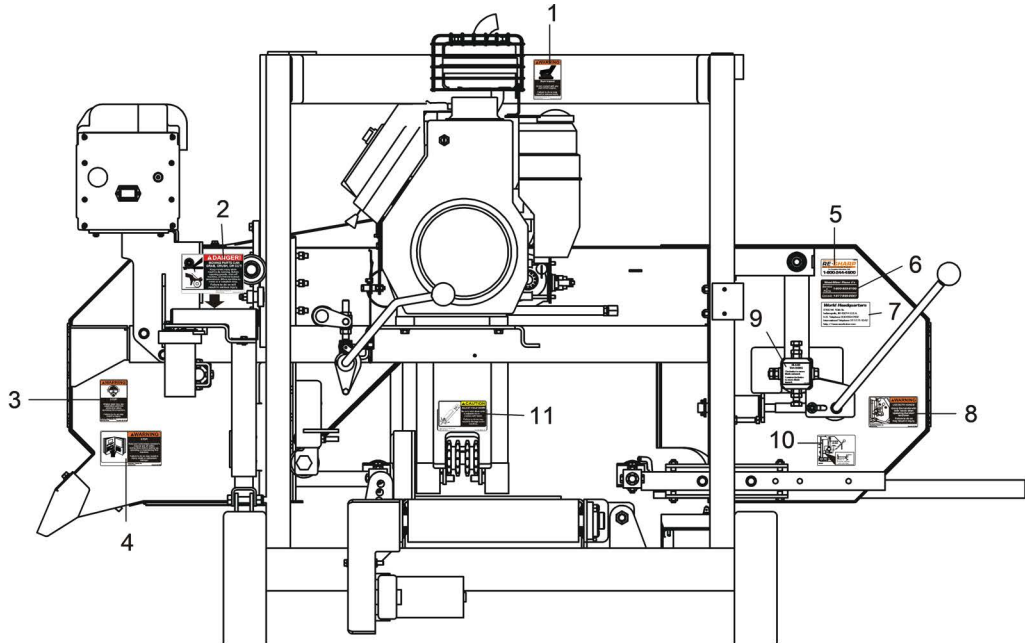

REF	PART #	DESCRIPTION	COMMENTS	QTY.
1	014419	DECAL, HOT ENGINE WARNING		1
2	028720	DECAL, MOVING PARTS DANGER		1
3	S11753	DECAL, EYE/EAR PROTECTION WARNING		1
4	016402	DECAL, READ MANUAL WARNING		1
5	P12879	DECAL, RESHARP INFO		1
6	S12117	DECAL, TOLL FREE PARTS		1
7	015840	DECAL, WORLD HEADQUARTERS ADDRESS		1
8	049367	DECAL, TENSIONER WARNING		1
9	P11789	DECAL, BLADE TRACK INFO		1

REF	PART #	DESCRIPTION	COMMENTS	QTY.
10	049368	DECAL, BLADE TENSION INFO		1
11	063189	DECAL, ADJUST HOLD-DOWN CAUTION		1
12	P10364	DECAL, 12V ELECTRICAL SYSTEM WARNING		1
13	P11754	DECAL, SAWDUST CHUTE WARNING		1
14	S11752	DECAL, BLADE DANGER		2
15	003235	DECAL, WOOD-MIZER WEBSITE LOGO		1
16	059509	DECAL, WOOD-MIZER COVER LOGO		1
17	033254	DECAL, MOVING PARTS DANGER		2
18	059508	DECAL, HR120 COVER LOGO		1
	025724	DECAL, HR130 COVER LOGO		1
19	015849	DECAL, BLADE GUIDE ARM STRIPE		1

4.7 Saw Head Decals
Before 4/10

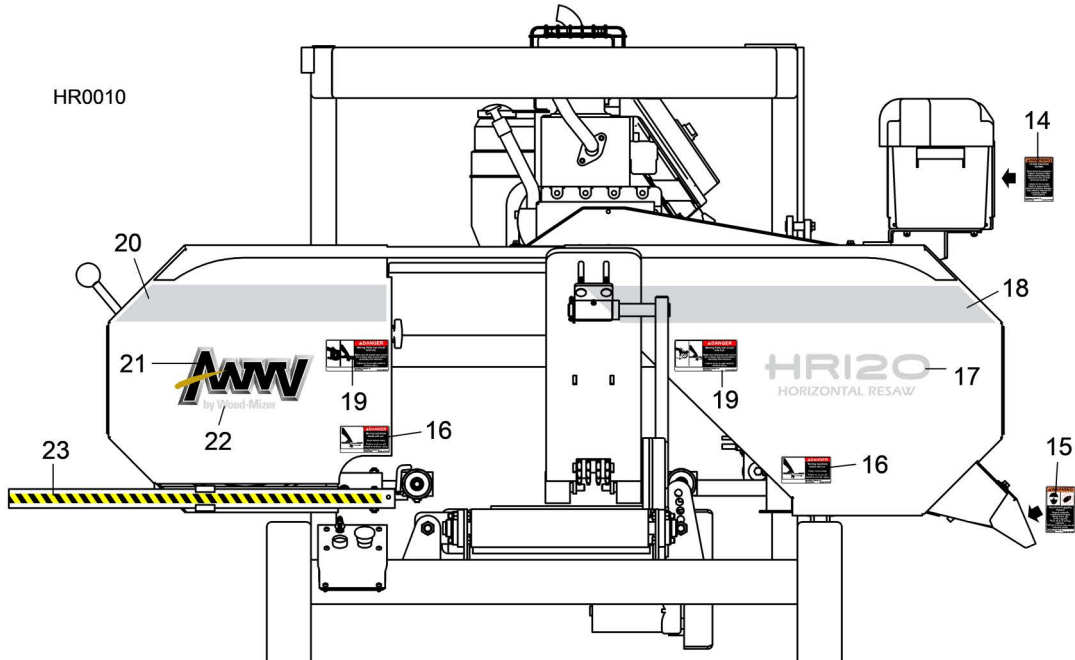
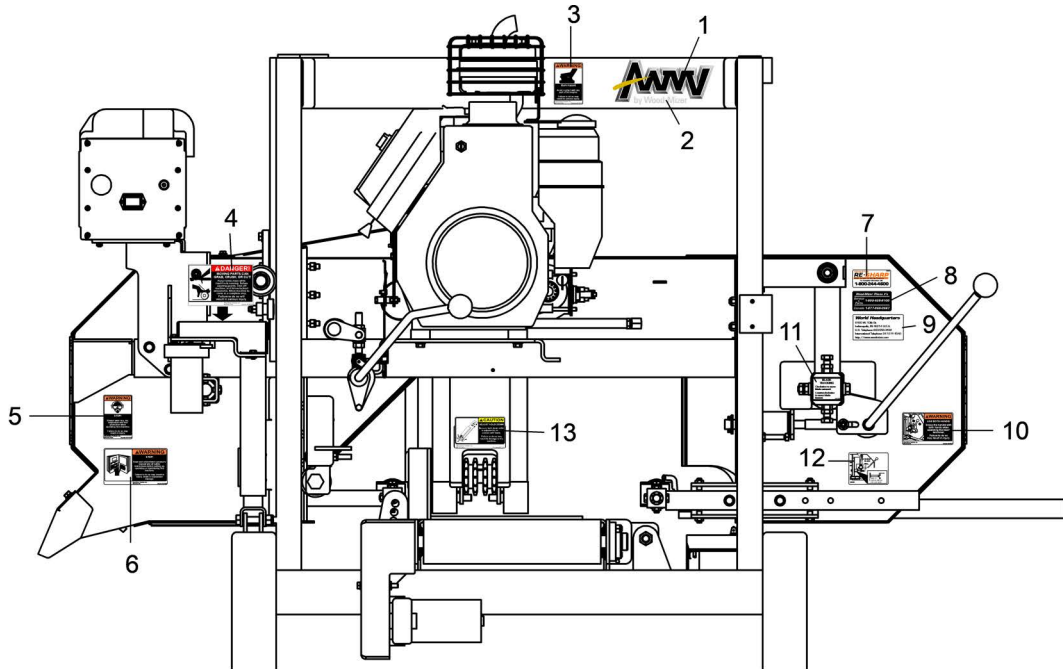

REF	PART #	DESCRIPTION	COMMENTS	QTY.
1	052409	DECAL, AWMV LOGO 8"		1
2	059507	DECAL, BY WOOD-MIZER FOR 8" AWMV LOGO		1
3	014419	DECAL, HOT ENGINE WARNING		1
4	028720	DECAL, MOVING PARTS DANGER		1
5	S11753	DECAL, EYE/EAR PROTECTION WARNING		1
6	016402	DECAL, READ MANUAL WARNING		1
7	P12879	DECAL, RESHARP INFO		1
8	S12117	DECAL, TOLL FREE PARTS		1

REF	PART #	DESCRIPTION	COMMENTS	QTY.
9	015840	DECAL, WORLD HEADQUARTERS ADDRESS		1
10	049367	DECAL, TENSIONER WARNING		1
11	P11789	DECAL, BLADE TRACK INFO		1
12	049368	DECAL, BLADE TENSION INFO		1
13	063189	DECAL, ADJUST HOLD-DOWN CAUTION		1
14	P10364	DECAL, 12V ELECTRICAL SYSTEM WARNING		1
15	P11754	DECAL, SAWDUST CHUTE WARNING		1
16	S11752	DECAL, BLADE DANGER		2
17	059509	DECAL, HR120 LOGO		1
18	059511	DECAL, HR120 RIGHT BLADE COVER STRIPE		1
19	033254	DECAL, MOVING PARTS DANGER		2
20	059510	DECAL, HR120 LEFT BLADE COVER STRIP		1
21	052271	DECAL, AWMV LOGO 11"		1
22	059508	DECAL, BY WOOD-MIZER FOR 11" AWMV LOGO		1
23	015849	DECAL, BLADE GUIDE ARM STRIPE		1

SECTION 4 CONTROL & BATTERY BOXES

4.1 Battery Box Assembly

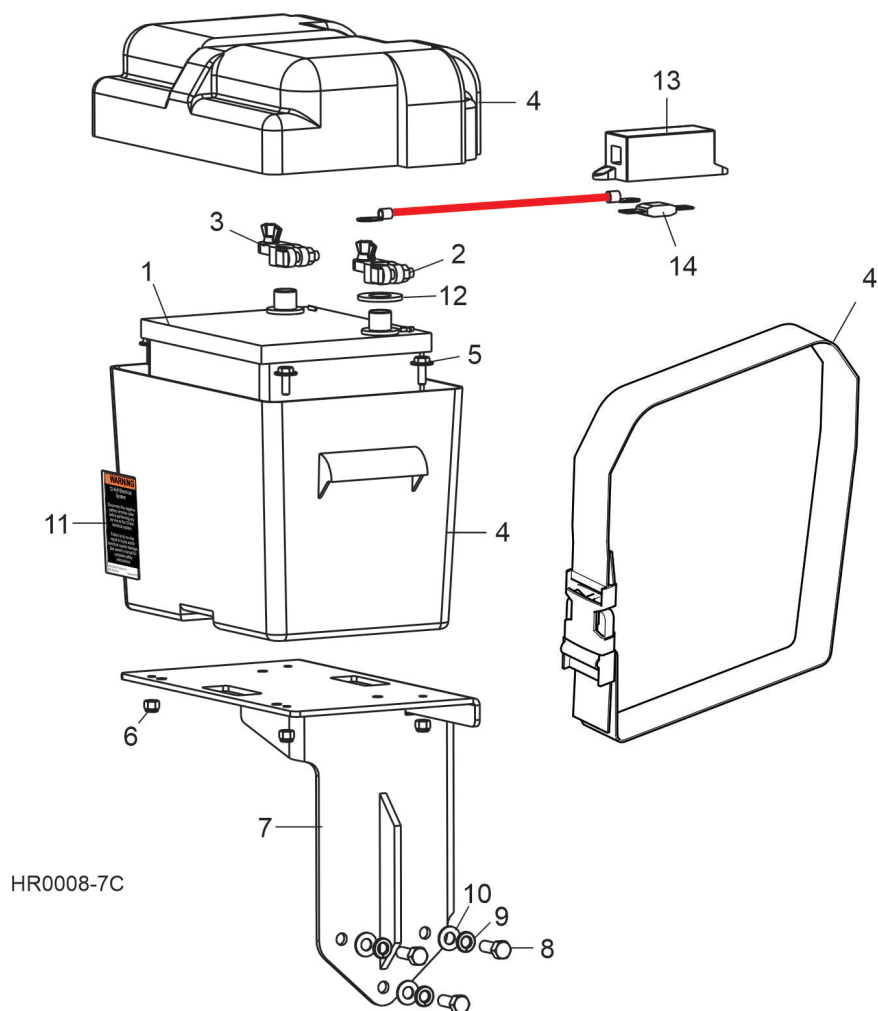

REF	PART #	DESCRIPTION	COMMENTS	QTY.
	034609	BATTERY MODULE, HR120 G18/G25/D17		1
1	028004	Battery, 12 Volt 600U	Available in assemblies only.	1
2	033358	Terminal, Positive Battery		1
3	033359	Terminal, Negative Battery		1
4	016413	Box Assembly, LT15 Battery		1
5	F05005-134	Bolt, 1/4-20x 3/4" W/Conical Washer		4
6	F05010-69	Nut, 1/4-20 Hex Nylon Lock		4
7	034899	Mount Weldment, Battery/Control Box		1
8	F05007-7	Bolt, 3/8-16 x 1" Hex Head		3
9	F05011-4	Washer, 3/8" Split		3
10	F05011-3	Washer, 3/8" SAE Flat		3
11	P10364	Decal, 12V Warning		1
12	P12161	Washer, Felt Battery Terminal		1
	052372	FUSEHOLDER ASSEMBLY, MEGA FUSE 150A		1
13	052371	Fuseholder, Mega Fuse		1
14	052370-150	Fuse, 150A Mega		1

4.2 Feed Control Box Assembly (HR120G15/G18/G25)

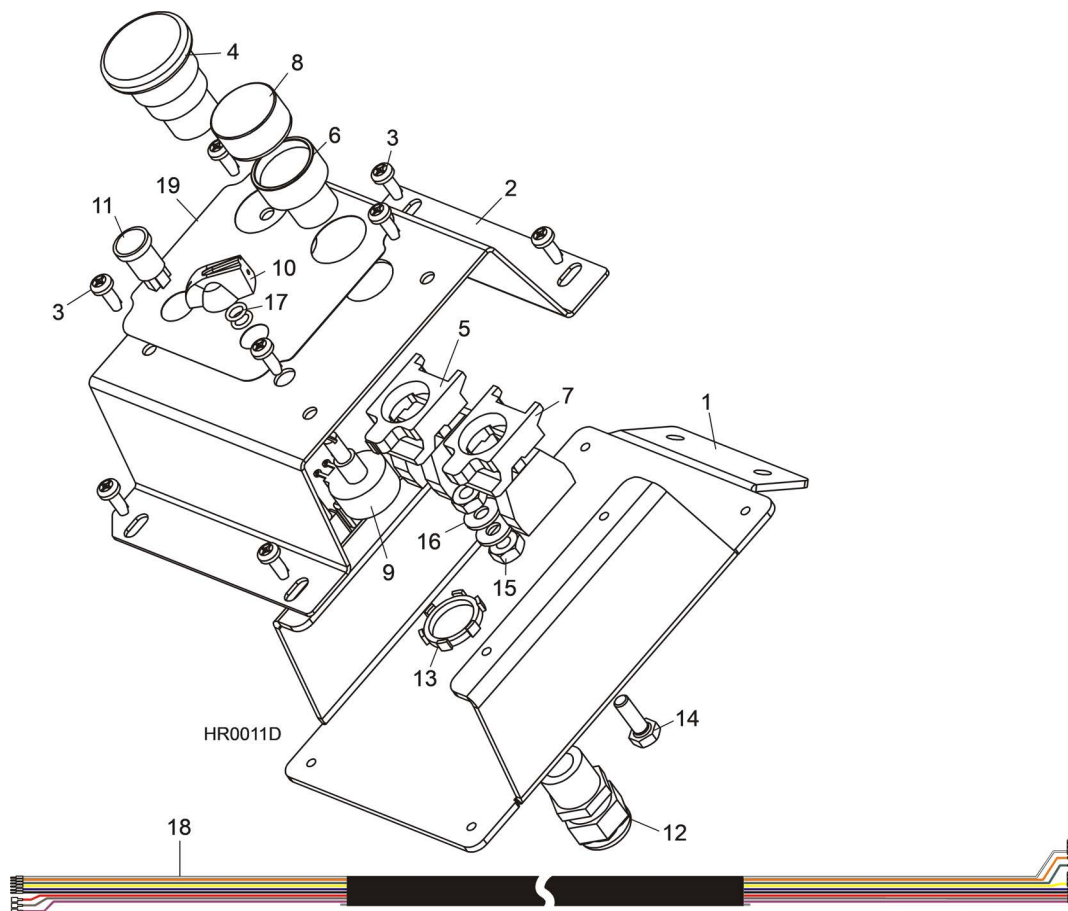

REF	PART #	DESCRIPTION	COMMENTS	QTY.
	053569	CONTROL ASSEMBLY, HR120 G15/G18/G25 FEED		1
1	053567	Plate, HR120 Feed Control Base		1
2	053568	Plate, HR120 Feed Control Face		1
3	F05015-17	Screw, #10-24 x 1/2" Phillips Pan Head Type 23		8
4	024945	Operator, 22mm ZB4 Red Maintained E-Stop Push Button		1
5	050527	Base, 1 NC 1 NO Contact ZB4		1
6	050152	Switch Head, Green Guarded		1
7	025242	Switch Body, 1NO 22mm ZB4		1
8	053678	Boot, 22mm Round Sealing Push Button		1
9	053572	Switch Assembly, HR120 Feed Rate Pot		1
10	P06257	Knob, Speed Control		1
11	E20483	Light, Green 12V .187 Tabs		1
12	051299	Connector, 1/2" NPT .17 - .47 Cord Grip	Connector 051299 & Lock Nut E20461 replace grommet P04137 (2/10).	1
13	E20461	Nut, 1/2" Connector Lock		1
14	F05005-1	Bolt, 1/4-20 x 3/4" Hex Head Full Thread		1
15	F05010-129	Nut, 1/4-20 Heavy Duty Hex Jam		2
16	F05011-11	Washer, 1/4" SAE Flat		2
17	033476	O-Ring, 7/32" ID #009		2
18	053573	Harness, HR120 G15/G18/G25 Operator		1

4 **Control & Battery Boxes**
Feed Control Box Assembly (HR120G15/G18/G25)

REF	PART #	DESCRIPTION	COMMENTS	QTY.
19	053570	Decal, HR120 Feed Control		1

4.3 Feed Control Box Assembly (HR120D17)

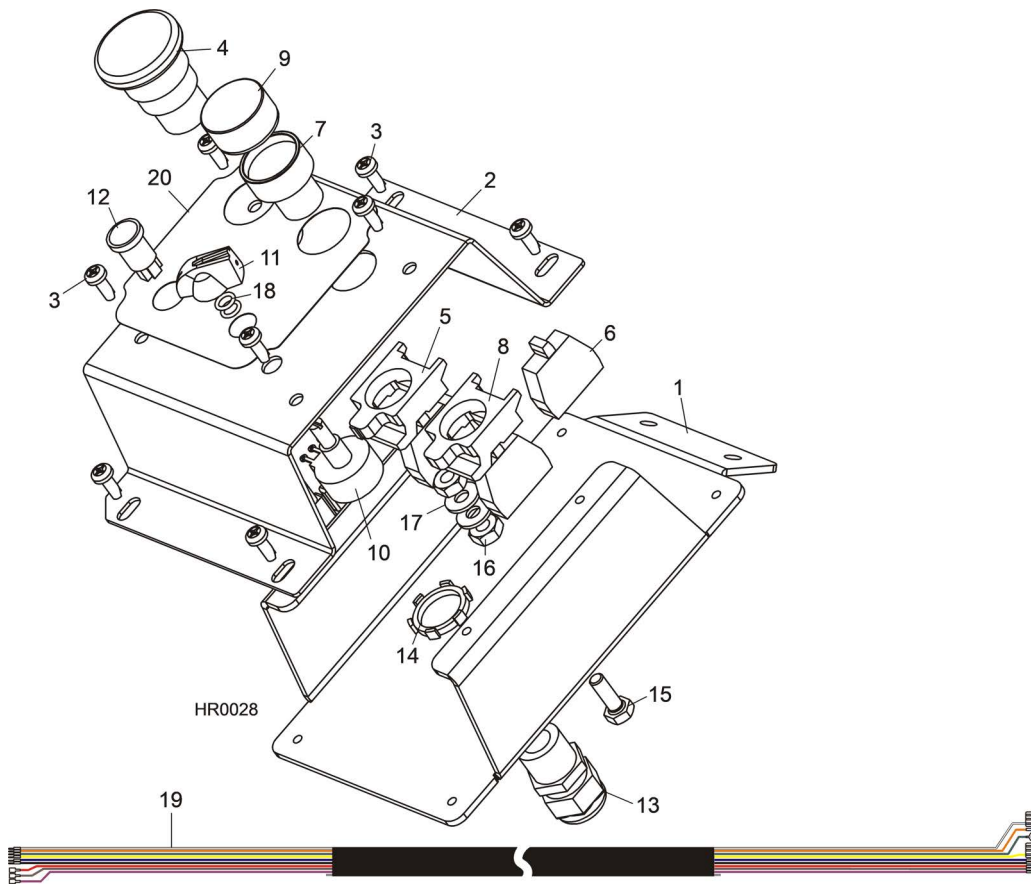

REF	PART #	DESCRIPTION	COMMENTS	QTY.
	069301	CONTROL ASSEMBLY, HR120 D18 FEED		1
1	053567	Plate, HR120 Feed Control Base		1
2	053568	Plate, HR120 Feed Control Face		1
3	F05015-17	Screw, #10-24 x 1/2" Phillips Pan Head Type 23		8
4	024945	Operator, 22mm ZB4 Red Maintained E-Stop Push Button		1
5	025161	Base, 1 NC Contact ZB4		1
6	050540	Contact, NC ZBE102		1
7	050152	Switch Head, Green Guarded		1
8	025242	Switch Body, 1NO 22mm ZB4		1
9	053678	Boot, 22mm Round Sealing Push Button		1
10	053572	Switch Assembly, HR120 Feed Rate Pot		1
11	P06257	Knob, Speed Control		1
12	E20483	Light, Green 12V .187 Tabs		1
13	051299	Connector, 1/2" NPT .17 - .47 Cord Grip		1
14	E20461	Nut, 1/2" Connector Lock		1
15	F05005-1	Bolt, 1/4-20 x 3/4" Hex Head Full Thread		1
16	F05010-129	Nut, 1/4-20 Heavy Duty Hex Jam		2
17	F05011-11	Washer, 1/4" SAE Flat		2
18	033476	O-Ring, 7/32" ID #009		2
19	053690	Harness, HR120 D18 Operator		1
20	053570	Decal, HR120 Feed Control		1

4.4 Feed Control Box Assembly (HR120E10)

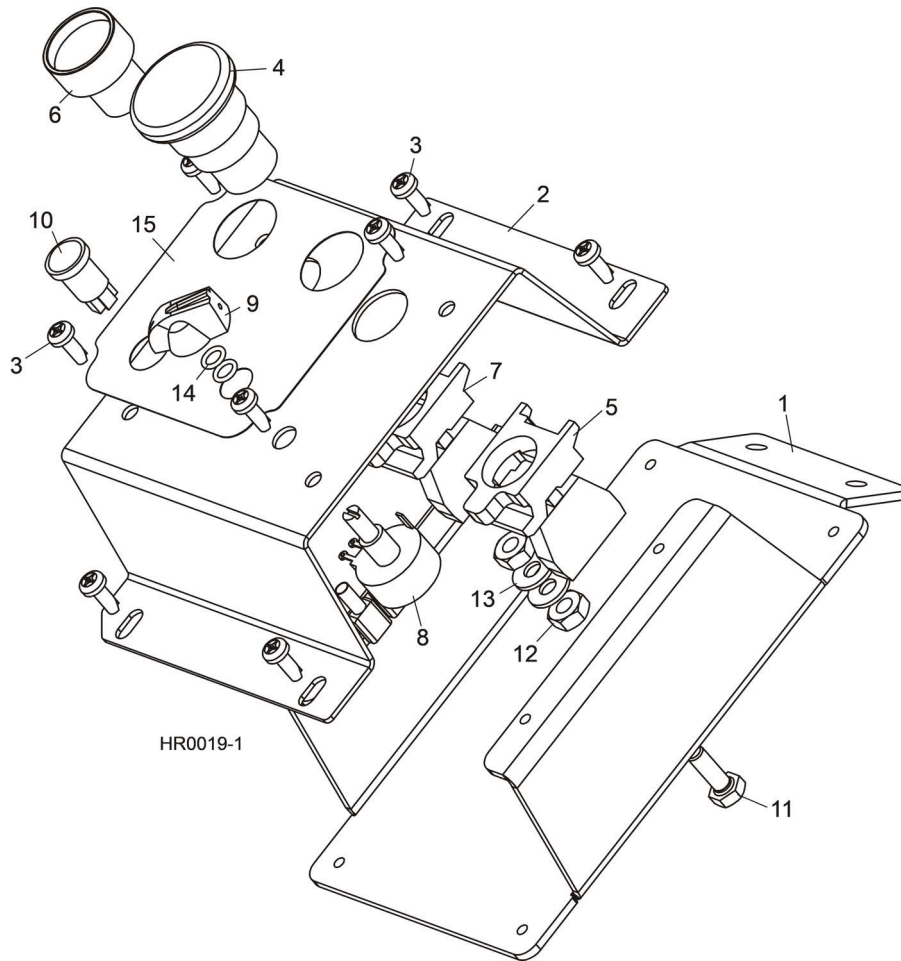

REF	PART #	DESCRIPTION	COMMENTS	QTY.
	053637	CONTROL ASSEMBLY, HR120 E10 FEED		1
1	053567	Plate, HR120 Feed Control Base		1
2	053568	Plate, HR120 Feed Control Face		1
3	F05015-17	Screw, #10-24 x 1/2" Phillips Pan Head Type 23		8
4	024945	Operator, 22mm ZB4 Red Maintained E-Stop Push Button		1
5	025161	Base, 1 NC 22mm ZB4		1
6	050152	Switch Head, Green Guarded		1
7	025242	Switch Body, 1NO 22mm ZB4		1
8	053572	Switch Assembly, HR120 Feed Rate Pot		1
9	P06257	Knob, Speed Control		1
10	E20483	Light, Green 12V .187 Tabs		1
11	F05005-1	Bolt, 1/4-20 x 3/4" Hex Head Full Thread		1
12	F05010-129	Nut, 1/4-20 Heavy Duty Hex Jam		2
13	F05011-11	Washer, 1/4" SAE Flat		2
14	033476	O-Ring, 7/32" ID #009		2
15	053608	Decal, HR120 E10 Feed Control		1

4.5 Up/Down Control Box Assembly (G15/G18/G25)

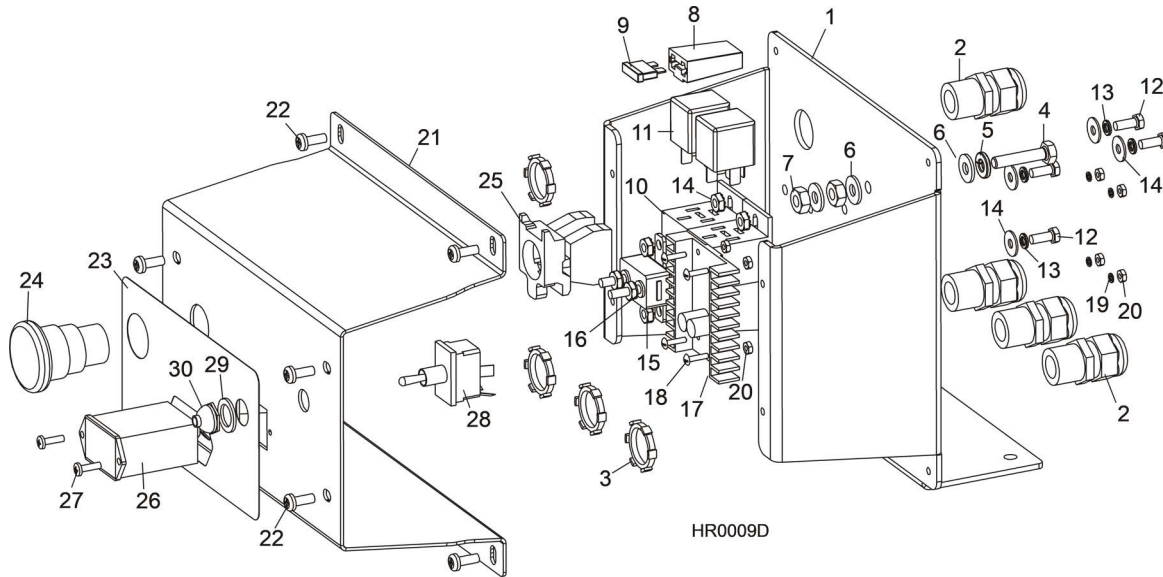

HR0009D

REF	PART #	DESCRIPTION	COMMENTS	QTY.
	053581	CONTROL ASSEMBLY, HR120G15/HR120G18 UP/DOWN		1
	053582	CONTROL ASSEMBLY, HR120G25 UP/DOWN		1
1	063181	Plate, Up/Down Control Base	Field Replacement Kit 057829-FR replaces Driver Module 057829 originally supplied prior to 1/10. Module B-, B+, M1 & M2 connections changed from terminal block to spade terminal to allow proper wiring size to be used. Kit includes new driver module w/spade terminals, quick connect terminals and instructions. Control Base Plate 063181 modified to reposition driver module to accommodate spade terminals. Four F05010-43 #4-40 Hex Nuts added to support driver module.	1
2	051299	Connector, 1/2" NPT .17 - .47 Cord Grip	Connector 051299 & Lock Nut E20461 replace grommet P04137 (2/10).	4
3	E20461	Nut, 1/2" Connector Lock		4
4	F05005-3	Bolt, 1/4-20 x 1 1/4" Hex Head Full Thread		1
5	F05011-14	Washer, 1/4" Split Lock		1
6	F05011-11	Washer, 1/4" SAE Flat		3
7	F05010-129	Nut, 1/4-20 Heavy Duty Hex Jam		2
8	052354	Fuseholder, ATO 16 GA Red SXL 20" Wires		1
9	024150-4	Fuse, 4A ATO Pink Blade		1
10	050033	Socket, Relay Plug		2
11	051335	Relay, ISO 12V Coil w/Diode		2
12	F05004-27	Bolt, #10-24 x 1/2" Indented Hex Head Stainless Steel		4
13	F05011-20	Washer, #10 Split Lock		4

REF	PART #	DESCRIPTION	COMMENTS	QTY.
14	F05011-18	Washer, #10 SAE Flat		4
15	F05010-14	Nut, #10-24 Self-Locking Hex		4
16	E20431	Breaker, 30A Manual Reset Circuit		1
17	057829-FR	Driver Kit, 25A DC Motor Field Replacement	Field Replacement Kit 057829-FR replaces Driver Module 057829 originally supplied prior to 1/10. Module B-, B+, M1 & M2 connections changed from terminal block to spade terminal to allow proper wiring size to be used. Kit includes new driver module w/spade terminals, quick connect terminals and instructions. Control Base Plate 063181 modified to reposition driver module to accommodate spade terminals. Four F05010-43 #4-40 Hex Nuts added to support driver module.	1
18	F05004-14	Screw, #4-40 x 1/2" Slotted Round Head		4
19	F05011-21	Washer, #4 Split Lock		4
20	F05010-43	Nut, #4-40 Hex	Field Replacement Kit 057829-FR replaces Driver Module 057829 originally supplied prior to 1/10. Module B-, B+, M1 & M2 connections changed from terminal block to spade terminal to allow proper wiring size to be used. Kit includes new driver module w/spade terminals, quick connect terminals and instructions. Control Base Plate 063181 modified to reposition driver module to accommodate spade terminals. Four F05010-43 #4-40 Hex Nuts added to support driver module.	8
21	063180	Plate, Up/Down Control Front	Front panel 063180 modified to accept self-tapping screw F05015-28 to mount hour meter (6/12). Use #6-32 x 3/4" Socket Button Head Screw F05004-93 and Self Locking Nut F05010-59 to mount hour meters on older panels.	1
22	F05015-17	Bolt, #10-24 x 1/2" Phillips Pan Head Type 23		8
23	053571	Decal, HR120 Up/Down Control Box		1
24	024945	Operator, 22mm ZB4 Red Maintained E-Stop Push Button		1
25	050527	Base, 1 NC 1 NO Contact ZB4		1
26	015401	Meter, Rectangle Mount Hour		1
27	F05015-28	Screw, #6-32 x 1/2" Phillips Pan Head Type 23	Front panel 063180 modified to accept self-tapping screw F05015-28 to mount hour meter (6/12). Use #6-32 x 3/4" Socket Button Head Screw F05004-93 and Self Locking Nut F05010-59 to mount hour meters on older panels.	2

REF	PART #	DESCRIPTION	COMMENTS	QTY.
28	024200	Switch, DPDT 21A Reverse Momentary Spade Toggle		1
29	P05251-1	Washer, 1/2" ID x 3/4" OD x 1/16" Nylon		1
30	P02575	Boot, Toggle Switch		1

4.6 Up/Down Control Box Assembly (D17)

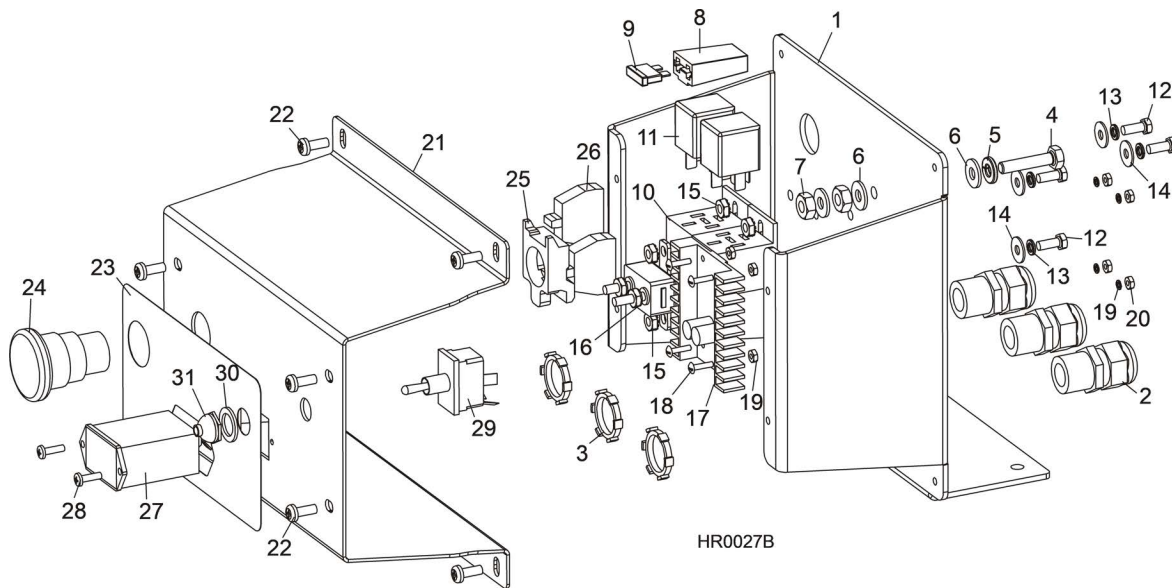

REF	PART #	DESCRIPTION	COMMENTS	QTY.
	069300	CONTROL ASSEMBLY, HR120 D17/D18 UP/DOWN		1
1	063181	Plate, Up/Down Control Base		1
2	051299	Connector, 1/2" NPT .17 - .47 Cord Grip		4
3	E20461	Nut, 1/2" Connector Lock		4
4	F05005-3	Bolt, 1/4-20 x 1 1/4" Hex Head Full Thread		1
5	F05011-14	Washer, 1/4" Split Lock		1
6	F05011-11	Washer, 1/4" SAE Flat		3
7	F05010-129	Nut, 1/4-20 Heavy Duty Hex Jam		2
8	052354	Fuseholder, ATO 16 GA Red SXL 20" Wires		1
9	024150-4	Fuse, 4A ATO Pink Blade		1
10	024319	Socket, Relay Stackable		2
	073826	TPA, Delphi 5 Pos	Terminal position assurance locks not shown.	2
11	051335	Relay, ISO 12V Coil w/Diode		2
12	F05004-27	Bolt, #10-24 x 1/2" Indented Hex Head Stainless Steel		4
13	F05011-20	Washer, #10 Split Lock		4
14	F05011-18	Washer, #10 SAE Flat		4
15	F05010-14	Nut, #10-24 Self-Locking Hex		4
16	E20431	Breaker, 30A Manual Reset Circuit		1
17	057829-FR	Driver Kit, 25A DC Motor Field Replacement		1
18	F05004-14	Screw, #4-40 x 1/2" Slotted Round Head		4
19	F05011-21	Washer, #4 Split Lock		4
20	F05010-43	Nut, #4-40 Hex		8

REF	PART #	DESCRIPTION	COMMENTS	QTY.
21	063180	Plate, Up/Down Control Front	Front panel 063180 modified to accept self-tapping screw F05015-28 to mount hour meter (6/12). Use #6-32 x 3/4" Socket Button Head Screw F05004-93 and Self Locking Nut F05010-59 to mount hour meters on older panels.	1
22	F05015-17	Bolt, #10-24 x 1/2" Phillips Pan Head Type 23		8
23	053571	Decal, HR120 Up/Down Control Box		1
24	024945	Operator, 22mm ZB4 Red Maintained E-Stop Push Button		1
25	025161	Base, 1 NC Contact ZB4		1
26	050540	Contact, NC ZBE102		1
27	015401	Meter, Rectangle Mount Hour		1
28	F05015-28	Screw, #6-32 x 1/2" Phillips Pan Head Type 23	Front panel 063180 modified to accept self-tapping screw F05015-28 to mount hour meter (6/12). Use #6-32 x 3/4" Socket Button Head Screw F05004-93 and Self Locking Nut F05010-59 to mount hour meters on older panels.	2
29	024200	Switch, DPDT 21A Reverse Momentary Spade Toggle		1
30	P05251-1	Washer, 1/2" ID x 3/4" OD x 1/16" Nylon		1
31	P02575	Boot, Toggle Switch		1

4.7 Up/Down Control Box Assembly (HR120E10/HR120EA10)

HR120E10/HR120EA10 Rev. A1.01+

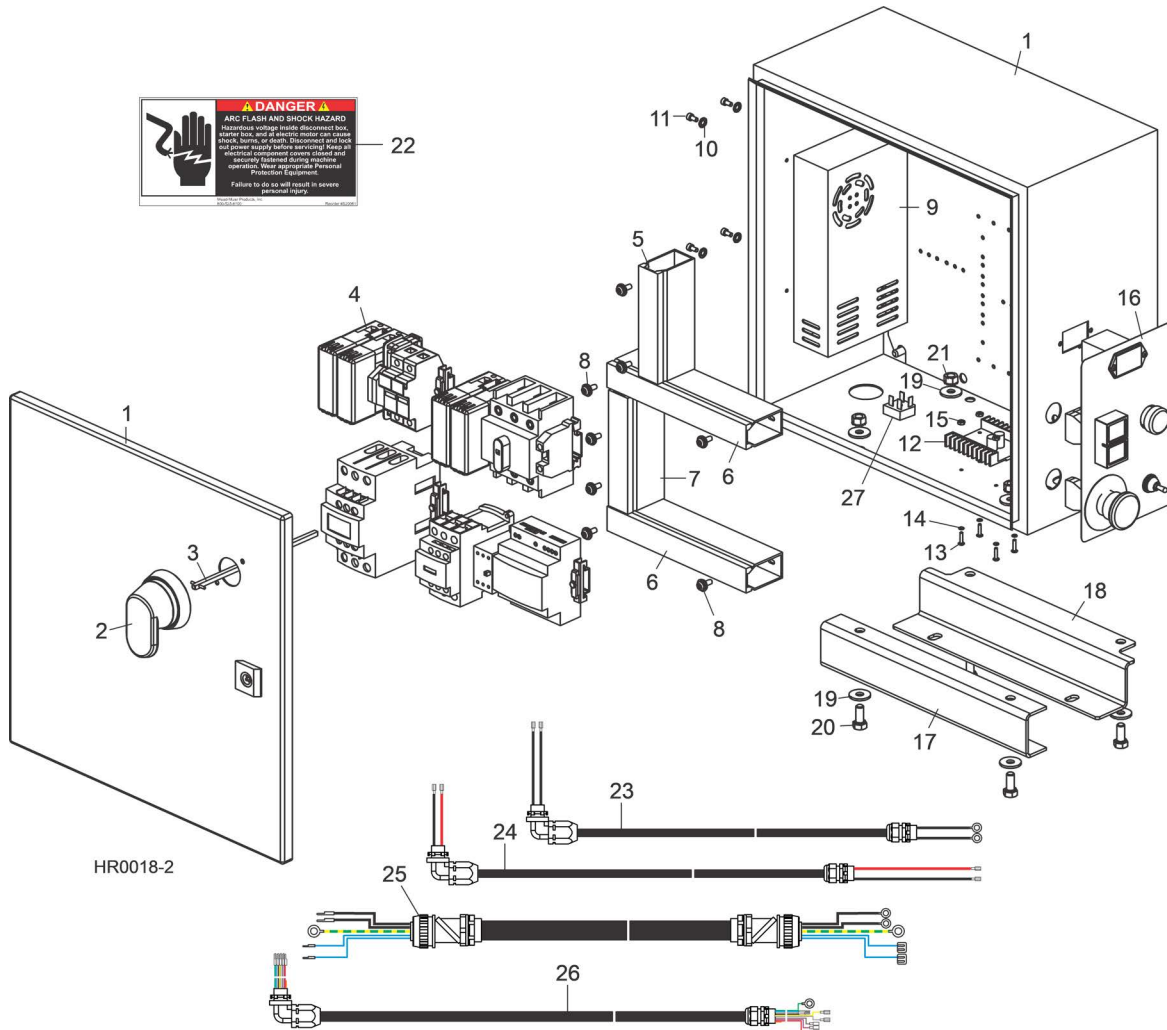

REF	PART #	DESCRIPTION	COMMENTS	QTY.
	053596	CONTROL ASSEMBLY, HR120EA10		1
1	053584	Enclosure, 16" x 16" x 8" Custom Electrical		1
2	050907-1	Handle, Red/Yellow Pistol Grip Operator 6mm	5mm Disconnect Shaft OXP5X265 replaced by vendor with 6mm shaft OXP6X290 (2/10). Replacement of any disconnect component requires replacement of disconnect, shaft and operator handle (050906-1, 050907-1 & 050908-1).	1
3	050908-1	Shaft, 290mm x 6mm Disconnect (Modified to 7")		1
4		Insert Panel Parts	(See Section 4.13)	
5	024472	Cable Duct, 2" x 1" x 6' Open Slot Gray		.069 Ft.
6	024472	Cable Duct, 2" x 1" x 6' Open Slot Gray		.111 Ft.
7	024472	Cable Duct, 2" x 1" x 6' Open Slot Gray		.073 Ft.
8	F05004-186	Screw, #10-24 x 1/2" Phillips Head		8
9	053592	Power Supply, 12VDC 320W Chassis Mount		1
10	F05011-57	Washer, 4mm Split Lock		4
11	F05004-255	Screw, M4-.7 x 8mm Socket Head		4

REF	PART #	DESCRIPTION	COMMENTS	QTY.
12	057829-1	Driver, 25A DC Motor w/Spade Terminals		1
13	F05004-14	Screw, #4-40 x 1/2" Slotted Round Head		4
14	F05011-21	Washer, #4 Split Lock		4
15	F05010-43	Nut, #4-40 Hex		4
16		Control Panel Parts	See Electrical Information in Online Manuals	
17	035991	Bracket, Front Mounting		1
18	035992	Bracket, Rear Mounting		1
19	F05011-16	Washer, 5/16" Standard Flat		4
20	F05006-5	Bolt, 5/16-18 x 3/4" Hex Head		4
21	F05010-20	Nut, 5/16-18 Self-Locking Hex		4
22	S20061	Decal, Electrical Hazard Danger		1
23	053593	Harness Assembly, HR120EA10 Feed Motor		1
24	053594	Harness Assembly, HR120EA10 Up/Down Motor		1
25	053589	Harness Assembly, HR120EA10 Blade Motor		1
26	053595	Harness Assembly, HR120EA10 Operator Control		1
27	E10456	Rectifier, 200 PIV 35A Bridge	Added after 10/4/2018	1

4.8 Control Panel Components (HR120EA10)

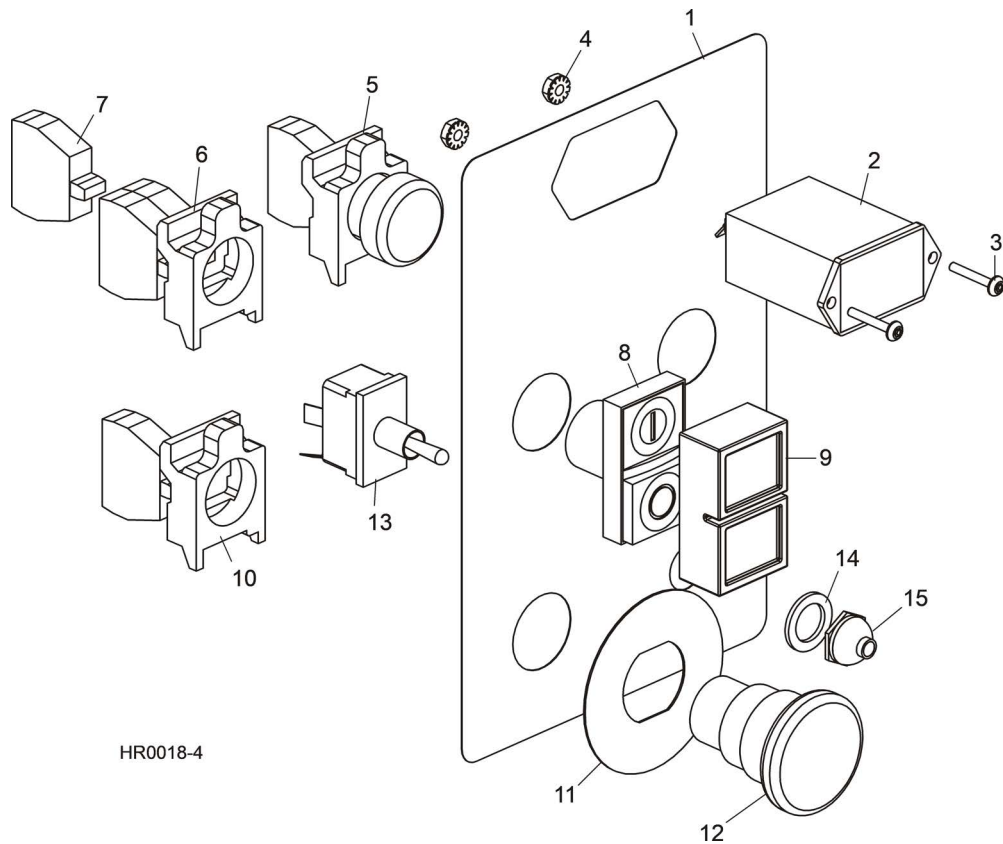

REF	PART #	DESCRIPTION	COMMENTS	QTY.
1	053626	DECAL, 1PH E10 CONTROL CABINET OPERATION	Decal modified Rev. A1.01 for improved operator control positions.	1
2	015401	METER, RECTANGE MOUNT HOUR		1
3	F05004-93	SCREW, #6-32 X 3/4" STAINLESS SOCKET BUTTON HEAD		2
4	F05010-69	NUT, #6-32 SELF-LOCKING HEX		2
5	024970-3	LIGHT, G433N 24V 22MM LED XB4 PILOT		1
6	025236-31	SWITCH BODY, 22MM GREEN LED 1NO 24V ZB4		1
7	050540	CONTACT, NC ZBE102		1
8	051746	SWITCH OPERATOR, 2 BUTTON W RED/GREEN PILOT		1
9	052501	BOOT, CLEAR ZB SWITCH SEALING		1
10	025161	SWITCH BODY, 1NC 22MM ZB4		1
11	050992	LEGEND, EMERGENCY STOP		1
12	024945	SWITCH OPERATOR, RED 22MM ZB4 RED MAINTAINED E-STOP		1
13	024200	SWITCH, DPDT 21A REV MOMENTARY SPADE TOGGLE		1
14	P05251-1	WASHER, 1/2" ID X 3/4" OD X 1/16" NYLON		1
15	P02575	BOOT, TOGGLE SWITCH		1

4.9 Control Assembly (HR130EB15)

HR130Rev. A2.01+

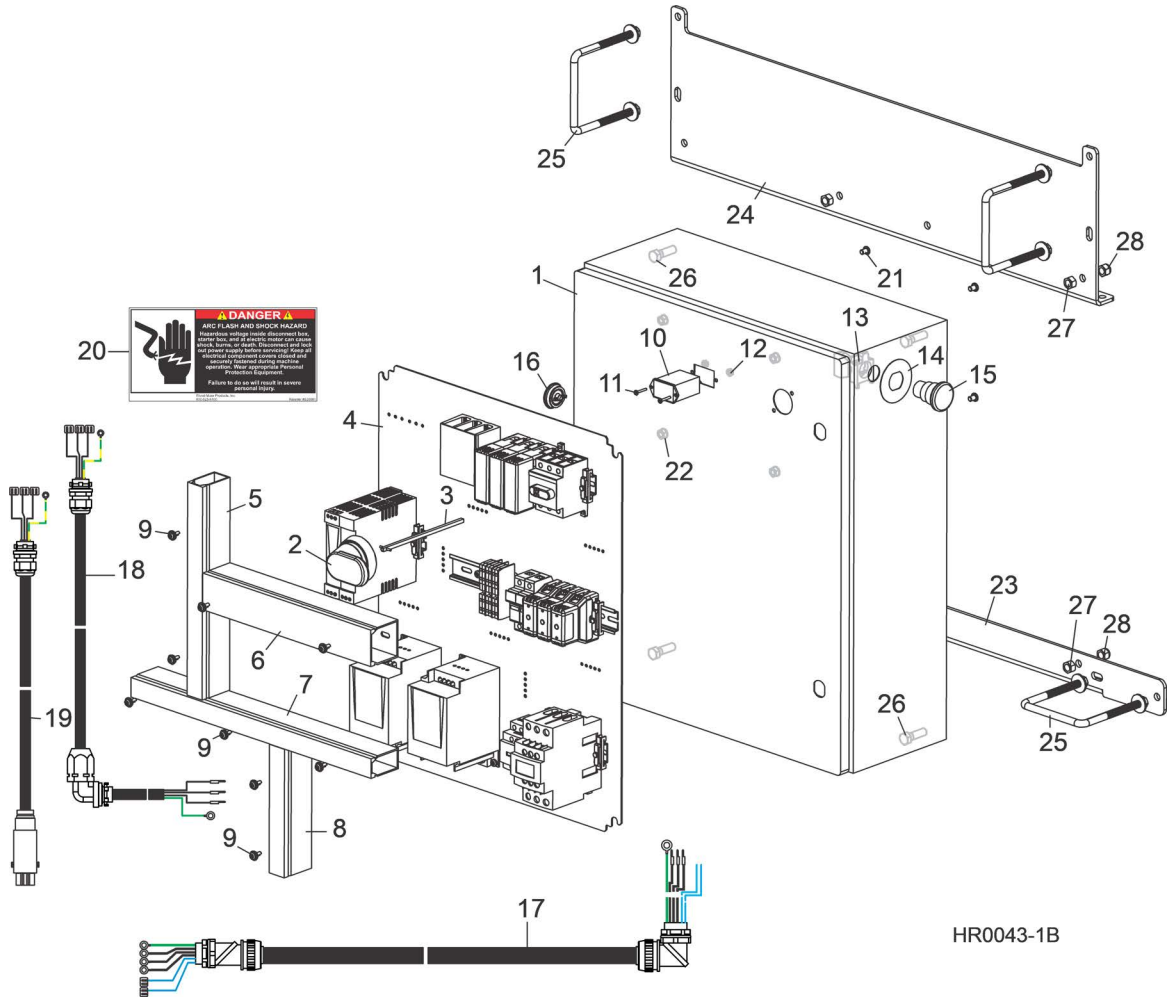

REF	PART #	DESCRIPTION	COMMENTS	QTY.
	053730	CONTROL ASSEMBLY, HR130EB15	(W/O NETWORKS ONLY)	1
	069880	CONTROL ASSEMBLY, HR130EB15	(W/NETWORKS ONLY)	1
1	069700	Enclosure, HR130 Control		1
2	050907-1	Handle, Red/Yellow Pistol Grip Operator 6mm		1
3	050908-1	Shaft, 290mm x 6mm Disconnect	Modified to 6 1/8"	1
4		Insert Panel Parts	(See Section 4.15)	
5	024472	Cable Duct, 2" x 1" x 6' Open Slot Gray		.167 Ft.
6	024471	Cable Duct, 2" x 2" x 6' Open Slot Gray		.111 Ft.
7	024472	Cable Duct, 2" x 1" x 6' Open Slot Gray		.243 Ft.
8	024472	Cable Duct, 2" x 1" x 6' Open Slot Gray		.101 Ft.
9	F05004-186	Screw, #10-24 x 1/2" Phillips Head		9
10	015401	Meter, Rectangle Mount Hour w/Gasket		1
11	F05004-93	Screw, #6-32 x 3/4" Socket Button Head Stainless		2
12	F05010-59	Nut, #6-32 Self-Locking Hex		2
13	025161	Switch Body, 1NC 22mm ZB4		1
14	050992	Legend, Emergency Stop		1
15	024945	Switch Operator, Red 22mm ZB4 Red Maintained E-Stop		1

4 Control & Battery Boxes

Control Assembly (HR130EB15)

REF	PART #	DESCRIPTION	COMMENTS	QTY.
16	024685	Plug, AS050 Oiltite		1
17	053741	Harness Assembly, HR130EB15 Blade Motor		1
18	053743	Cable Assembly, HR130 Up/Down Motor		1
19	073703	Cable Assembly, HR130 Feed Motor Connector	Replaces 053744 HR130 Feed Motor Cable Assembly to make it easy to disconnect conveyor feed motor for shipping purposes (Rev. A4.03).	1
20	S20061	Decal, Electrical Hazard Danger		1
21	F05005-62	Screw, 1/4-20 x 3/8" Socket Button Head		4
22	F05010-9	Nut, 1/4-20 Self-Locking Hex		4
		HR130 Operator Control Assembly Parts	(See Section 4.12)	
23	059679	PLATE, CONTROL BOX MOUNT		1
24	065185	PLATE, UPPER CONTROL BOX MOUNT		1
25	003207	BOLT, 3/8-16 X 4" X 5" U		4
26	F05007-123	BOLT, 3/8-16 X 1 1/4" HEX HEAD GRADE 5		4
27	F05010-1	NUT, 3/8-16 HEX		4
28	F05010-10	NUT, 3/8-16 HEX NYLON LOCK		4

4.10 Control Assembly (HR130EB15)

HR130Rev. A1.00 - A2.00

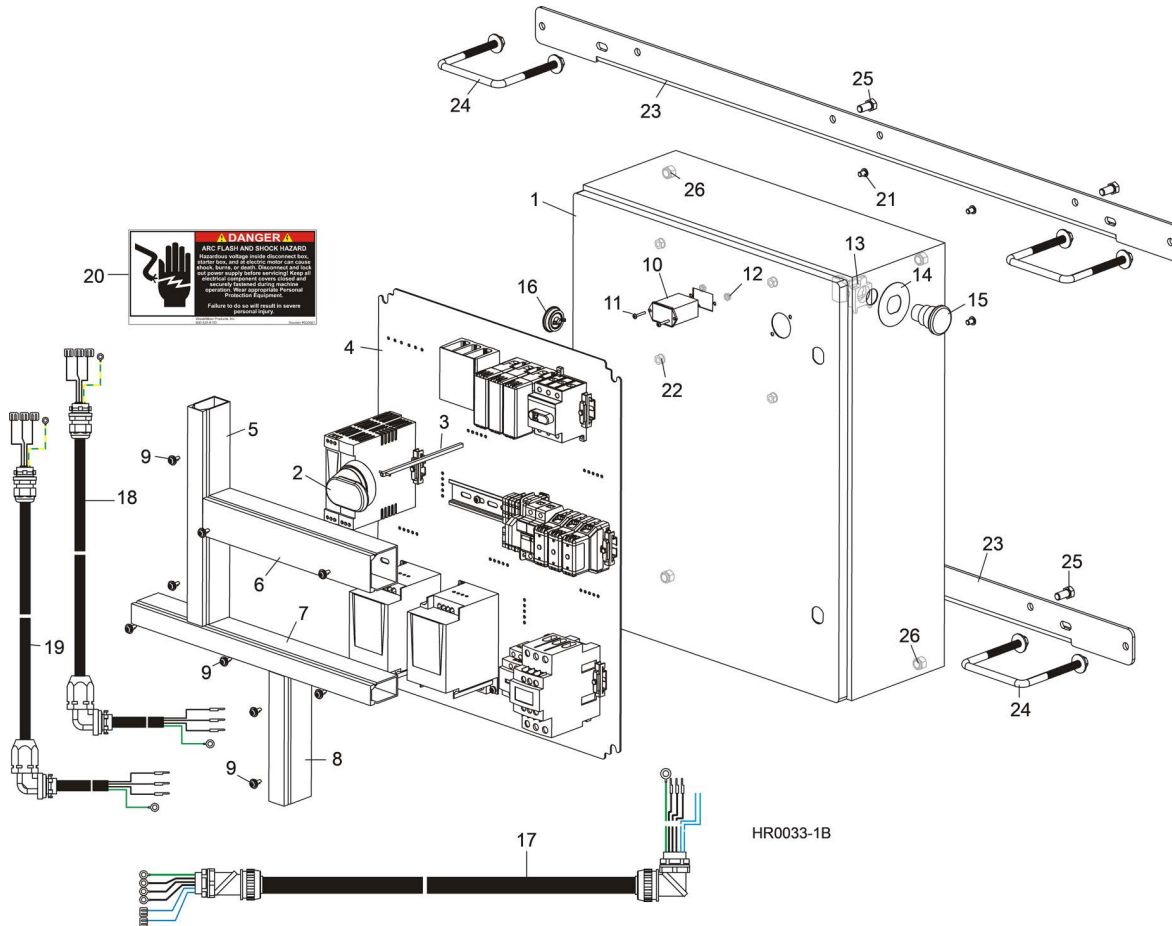

REF	PART #	DESCRIPTION	COMMENTS	QTY.
	053730	CONTROL ASSEMBLY, HR130EB15		1
	069880	CONTROL ASSEMBLY, HR130EB15 W/SETWORKS		1
1	069700	Enclosure, HR130 Control		1
2	050907-1	Handle, Red/Yellow Pistol Grip Operator 6mm		1
3	050908-1	Shaft, 290mm x 6mm Disconnect (Modified to 6 1/8")		1
4		Insert Panel Parts	See Section 4.16	
5	024472	Cable Duct, 2" x 1" x 6' Open Slot Gray		.167 Ft.
6	024471	Cable Duct, 2" x 2" x 6' Open Slot Gray		.111 Ft.
7	024472	Cable Duct, 2" x 1" x 6' Open Slot Gray		.243 Ft.
8	024472	Cable Duct, 2" x 1" x 6' Open Slot Gray		.101 Ft.
9	F05004-186	Screw, #10-24 x 1/2" Phillips Head		9
10	015401	Meter, Rectangle Mount Hour w/Gasket		1
11	F05004-93	Screw, #6-32 x 3/4" Socket Button Head Stainless		2
12	F05010-59	Nut, #6-32 Self-Locking Hex		2
13	025161	Switch Body, 1NC 22mm ZB4		1
14	050992	Legend, Emergency Stop		1
15	024945	Switch Operator, Red 22mm ZB4 Red Maintained E-Stop		1
16	024685	Plug, AS050 Oiltite		1

4 Control & Battery Boxes

Control Assembly (HR130EB15)

REF	PART #	DESCRIPTION	COMMENTS	QTY.
17	053741	Harness Assembly, HR130EB15 Blade Motor		1
18	053743	Cable Assembly, HR130 Up/Down Motor		1
19	053744	Cable Assembly, HR130 Feed Motor		1
20	S20061	Decal, Electrical Hazard Danger		1
21	F05005-62	Screw, 1/4-20 x 3/8" Socket Button Head		4
22	F05010-9	Nut, 1/4-20 Self-Locking Hex		4
		HR130 Operator Control Assembly Parts	See Section 4.13	
23	059679	PLATE, CONTROL BOX MOUNT	Lower mount plate modified and upper mount plate replaced Rev. A2.01 to remove interference with new powered board return option HRPBR (See Section 4.9).	2
24	003207	BOLT, 3/8-16 X 4" X 5" U		4
25	F05007-118	BOLT, 3/8-16 X 3/4" HEX HEAD GRADE 5		4
26	F05010-10	NUT, 3/8-16 HEX NYLON LOCK		4

4.11 Control Assembly (HR130EC15)

HR130Rev. A2.01+

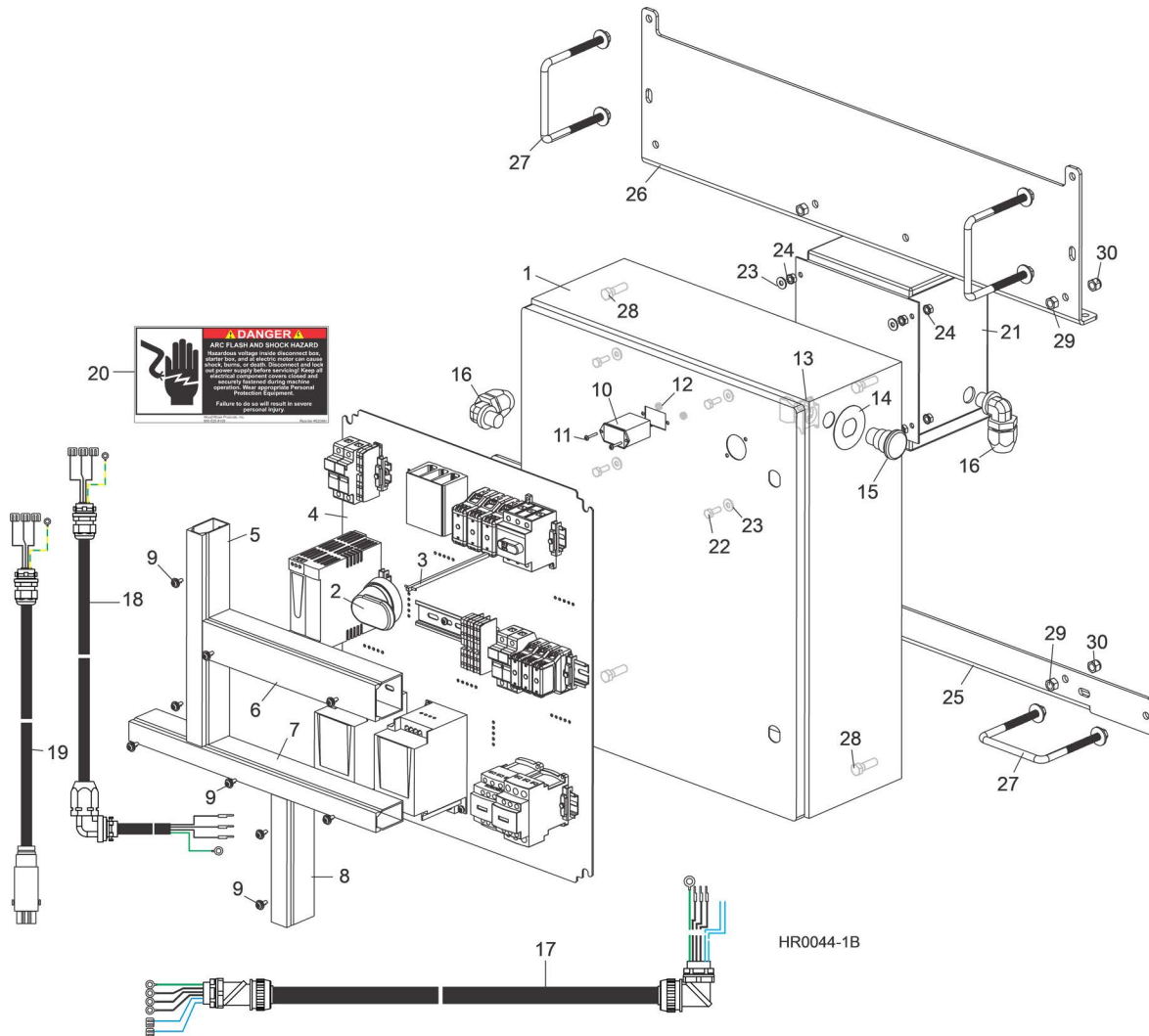

REF	PART #	DESCRIPTION	COMMENTS	QTY.
	053731	CONTROL ASSEMBLY, HR130EC15	(W/O NETWORKS ONLY)	1
	069881	CONTROL ASSEMBLY, HR130EC15	(W/NETWORKS ONLY)	1
1	069700	Enclosure, HR130 Control		1
2	050907-1	Handle, Red/Yellow Pistol Grip Operator 6mm		1
3	050908-1	Shaft, 290mm x 6mm Disconnect	(Modified to 6 1/8")	1
4		Insert Panel Parts	(See Section 4.16)	
5	024472	Cable Duct, 2" x 1" x 6' Open Slot Gray		.167 Ft.
6	024471	Cable Duct, 2" x 2" x 6' Open Slot Gray		.111 Ft.
7	024472	Cable Duct, 2" x 1" x 6' Open Slot Gray		.243 Ft.
8	024472	Cable Duct, 2" x 1" x 6' Open Slot Gray		.101 Ft.
9	F05004-186	Screw, #10-24 x 1/2" Phillips Head		9
10	015401	Meter, Rectangle Mount Hour w/Gasket		1
11	F05004-93	Screw, #6-32 x 3/4" Socket Button Head Stainless		2
12	F05010-59	Nut, #6-32 Self-Locking Hex		2
13	025161	Switch Body, 1NC 22mm ZB4		1
14	050992	Legend, Emergency Stop		1

4 Control & Battery Boxes

Control Assembly (HR130EC15)

REF	PART #	DESCRIPTION	COMMENTS	QTY.
15	024945	Switch Operator, Red 22mm ZB4 Red Maintained E-Stop		1
16	E22722	Connector, 1/2" 90° LiquidTite		1
17	053742	Harness Assembly, HR130EC15 Blade Motor		1
18	053743	Cable Assembly, HR130 Up/Down Motor		1
19	073703	Cable Assembly, HR130 Feed Motor Connector	Replaces 053744 HR130 Feed Motor Cable Assembly to make it easy to disconnect conveyor feed motor for shipping purposes (Rev. A4.03).	1
20	S20061	Decal, Electrical Hazard Danger		1
21	069705	Transformer, 240x480 Pri 120/240 Sec 2kA Sealed		1
22	F05005-101	Bolt, 1/4-20 x 1" Hex Head		4
23	F05011-11	Washer, 1/4" SAE Flat		8
24	F05010-9	Nut, 1/4-20 Self-Locking Hex		8
		HR130 Operator Control Assembly Parts	(See Section 4.12)	
25	059679	PLATE, CONTROL BOX MOUNT		1
26	065185	PLATE, UPPER CONTROL BOX MOUNT		1
27	003207	BOLT, 3/8-16 X 4" X 5" U		4
28	F05007-123	BOLT, 3/8-16 X 1 1/4" HEX HEAD GRADE 5		4
29	F05010-1	NUT, 3/8-16 HEX		4
30	F05010-10	NUT, 3/8-16 HEX NYLON LOCK		4

4.12 Operator Control Assembly (HR130)

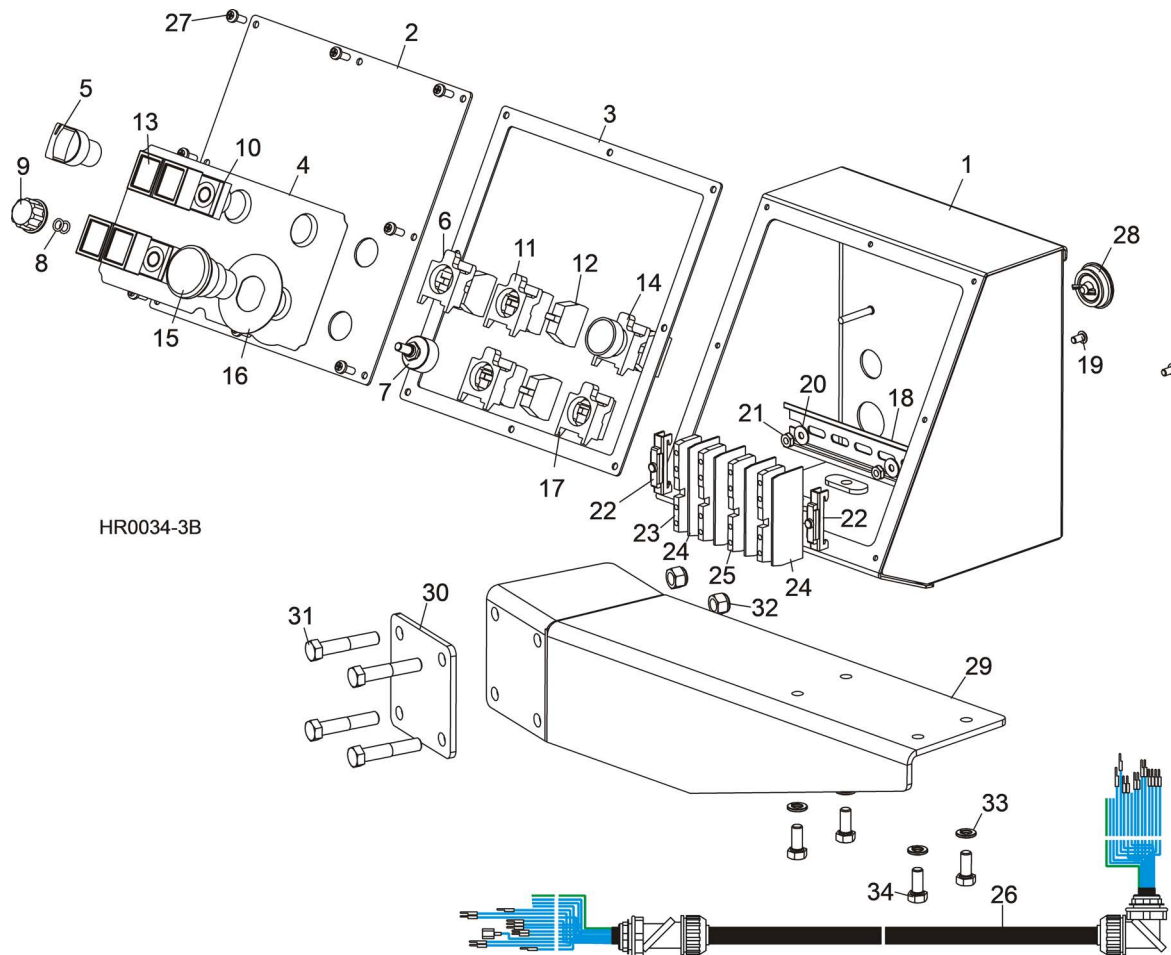

REF	PART #	DESCRIPTION	COMMENTS	QTY.
	069706	CONTROL ASSEMBLY, HR130 OPERATOR		1
	069882	CONTROL ASSEMBLY, HR130 OPERATOR W/SETWORKS		1
1	013965	Box Weldment, HR130 Operator Control (w/o Setworks Only)		1
2	013967	Plate, HR130 Operator Control Front (w/o Setworks Only)		1
3	013987	Gasket, HR130 Operator Control Box		1
4	112569	Decal, HR130 Operator Control	Replaced 069709 after 6/21/23 per ECN 37780	1
	069709	Decal, HR130 Operator Control		1
5	051744	Switch Operator, 3 Position Momentary Selector		1
6	050545	Switch Body, 2 NO Contacts		1
7	025200	Potentiometer Assembly, 4-20mA 24V w/Connectors		1
8	033476	O-Ring, 7/32" ID #009		2
9	033478	Knob, 1/4" ID Fluted Round Plastic		1
10	051746	Switch Operator, 2-Button Red/Green Pilot		2
11	025236-31	Switch Body, 22mm Green LED 1 NO 24V		2
12	025161	Contact, NC ZBE102		2

4 Control & Battery Boxes
Operator Control Assembly (HR130)

REF	PART #	DESCRIPTION	COMMENTS	QTY.
13	052501	Boot, Clear ZB Switch Sealing		2
14	024974-3	Switch, Green Push Button 1NO/1NC LED 24V		1
15	024945	Switch Operator, Red 22mm ZB4 Red Maintained E-Stop		1
16	050992	Legend, Emergency Stop		1
17	025161	Switch Body, 1NC 22mm ZB4		1
18	024474	Rail, 35mm x 7.5mm x 1m Steel DIN		.084
19	F05004-218	Screw, #10-24 x 3/8" Socket Button Head Stainless		2
20	F05011-18	Washer, #10 SAE Flat		2
21	F05010-14	Nut, #10-24 Self-Locking Hex		2
22	E22707	Clamp, Plastic DIN Rail		2
23	053534	Terminal Block, 4 Position Ground		1
24	053535	End Cap, 4 Position Terminal Block		4
25	053536	Terminal Block, 4 Position Common		3
26	053745	Harness Assembly, HR130 Operator		1
27	F05015-17	Bolt, #10-24 x 1/2" Phillips Pan Head Type 23		8
28	024685	Plug, AS050 Oiltite		1
	069841-4	Control Assy, HR130 Setworks	Replaced 069841-3 after 6/21/23 per ECN 37780	1
	069841-3	Control Assembly, HR130 Setworks (w/Setworks Only)	069841-3 replaces 069841-2 HR130 Setworks Control Assembly (Rev. A6.00). 069841-3 HR130 Setworks Control Assembly includes 069849-3 PLC Setworks Assembly and 069850-2 PLC Setworks HMI Assembly. Previously, 069841-2 replaced 069841 HR130 Setworks Control Assembly (Rev. A3.00). 069841 HR130 Setworks Control Assembly includes 069849 PLC Setworks Assembly and 069850 PLC Setworks HMI Assembly used only on HR130 prior to Rev. A3.00. Use 069849-2 and 069850-2 for HR130 Rev. A3.00-A5.00.	1
	112568	Plate, HR Front Panel	Replaced 013964 after 6/21/23 per ECN 37780	1
	013964	Plate, HR Front Panel		1
	013987	Gasket, Face Panel		1
	069710	Decal, HR130 Operator w/Setworks		1
	069883	Relay, 6A 24VDC w/Cage Clamp Socket		1
	069849-3	PLC Assembly, PLC Setworks		1
	112566-3	HMI Assembly, PLC Setworks	Replaced 069850-2 after 6/21/23 per ECN 37780	1
	069850-2	HMI Assembly, PLC Setworks		1
	069847	Cable, XBT N/R Communication		1
	069840	Encoder Assembly, HR130 Setworks		1
	069839	Cable Assembly, HR130 Setworks		1
	F05004-142	Screw, #6-32 x 3/8" Round Head Philips		2
	F05010-59	Nut, #6-32 Keps		2
29	059697	PLATE, 7GA ANGLED CONTROL MOUNT		1

REF	PART #	DESCRIPTION	COMMENTS	QTY.
30	059696	PLATE, 7GA X 3 1/2" SQUARE MOUNT		1
31	F05007-124	BOLT, 3/8-16 X 2" HEX HEAD		4
32	F05010-10	NUT, 3/8-16 HEX NYLON LOCK		4
33	F05011-13	WASHER, 5/16" SPLIT LOCK		4
34	F05006-102	BOLT, 5/16-18 X 3/4" HEX HEAD GRADE 5		4
	069850-KIT	ASSY, HR130 SETWORKS HMI RETRO		1
	112566-3	HMI Assembly, PLC Setworks		1
	112568	Plate, HR Front Panel		1
	112569	Decal, HR130 Operator Control		1

4.13 Control Insert Components (HR120E10/HR120EA10)

HR120E10/HR120EA10Rev. A1.01+

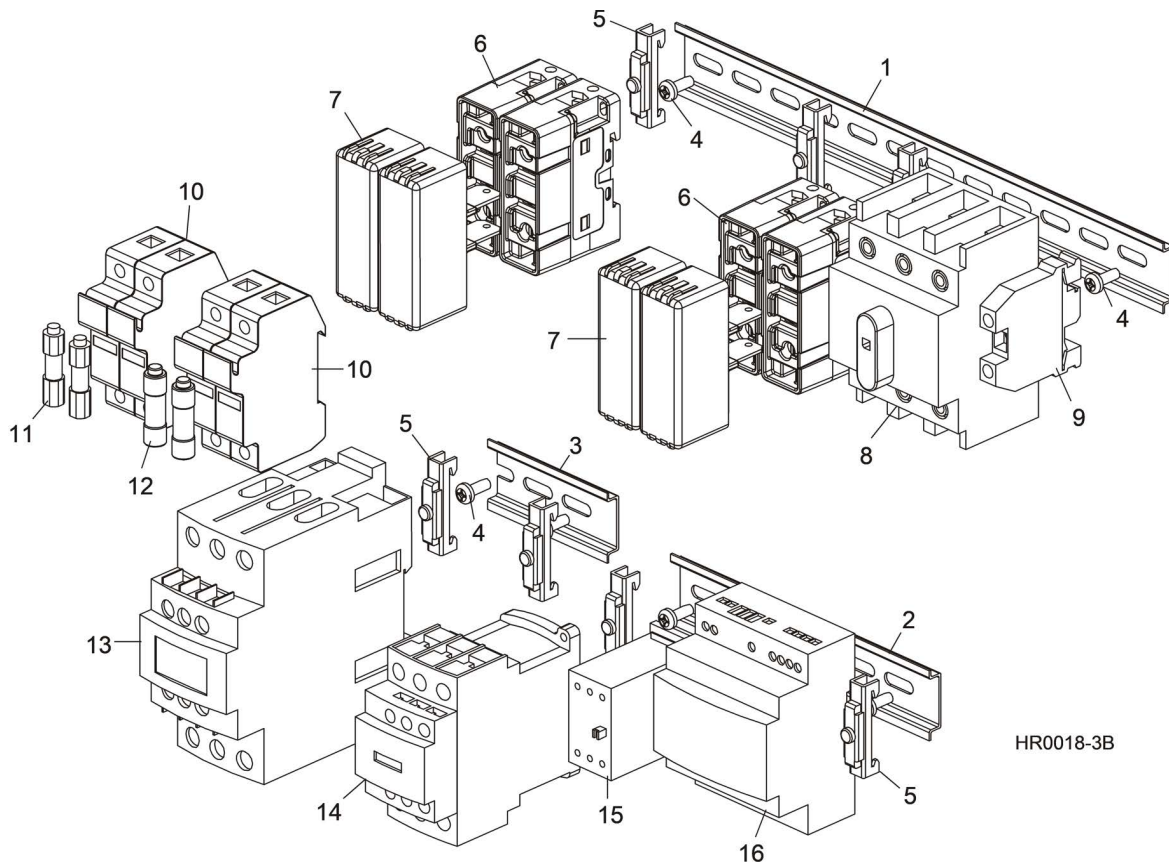

HR0018-3B

REF	PART #	DESCRIPTION	COMMENTS	QTY.
1	024474-12	DIN RAIL, 35MM X 7.5MM X 1M STEEL SYMMET- RICAL		.17 Ft.
2	024474-6	DIN RAIL, 35MM X 7.5MM X 1M STEEL SYMMET- RICAL		.090 Ft.
3	024474-3	DIN RAIL, 35MM X 7.5MM X 1M STEEL SYMMET- RICAL		.042 Ft.
4	F05015-17	SCREW, #10-24 X 1/2" PHILLIPS PAN HEAD TYPE 23		8
5	E22707	CLAMP, PLASTIC DIN RAIL		7
6	053586	FUSEHOLDER, 100A CUBE		4
7	053587	FUSE, 80A CLASS J CUBE		4
8	050906-1	DISCONNECT, 100A 3PH NON-FUSED	5mm Disconnect Shaft OXF5X265 replaced by vendor with 6mm shaft OXP6X290 (2/10). Replacement of any dis- connect component requires replacement of disconnect, shaft and operator handle (050906-1, 050907-1 & 050908-1).	1
9	053585	TERMINAL BLOCK, GROUNDING		1
10	052512	FUSE BLOCK, 2P CLASS CC 30A DIN		2

REF	PART #	DESCRIPTION	COMMENTS	QTY.
11	E22716	FUSE, 2A 600V CLASS CC	65A Contactor 053604 replaced 50A Contactor 053601 9/10 to provide adequate horsepower rating. Fuse E22716 replaces 050889 to meet CSA Standards.	2
12	052721	FUSE, 3.5A 600V CLASS CC DELAY		2
13	053604	CONTACTOR, 65A 3P 24VDC D-A SERIES	65A Contactor 053604 replaced 50A Contactor 053601 9/10 to provide adequate horsepower rating. Fuse E22716 replaces 050889 to meet CSA Standards.	1
14	052465	CONTACTOR, 32A 3P 24VDC COIL		1
15	053590	RELAY, 12VDC 2NO CONTROL		1
16	053591	POWER SUPPLY, 24VDC 60W DIN MOUNT		1

4.14 Control Insert Components (HR120E10)

HR120E10Rev. A1.00

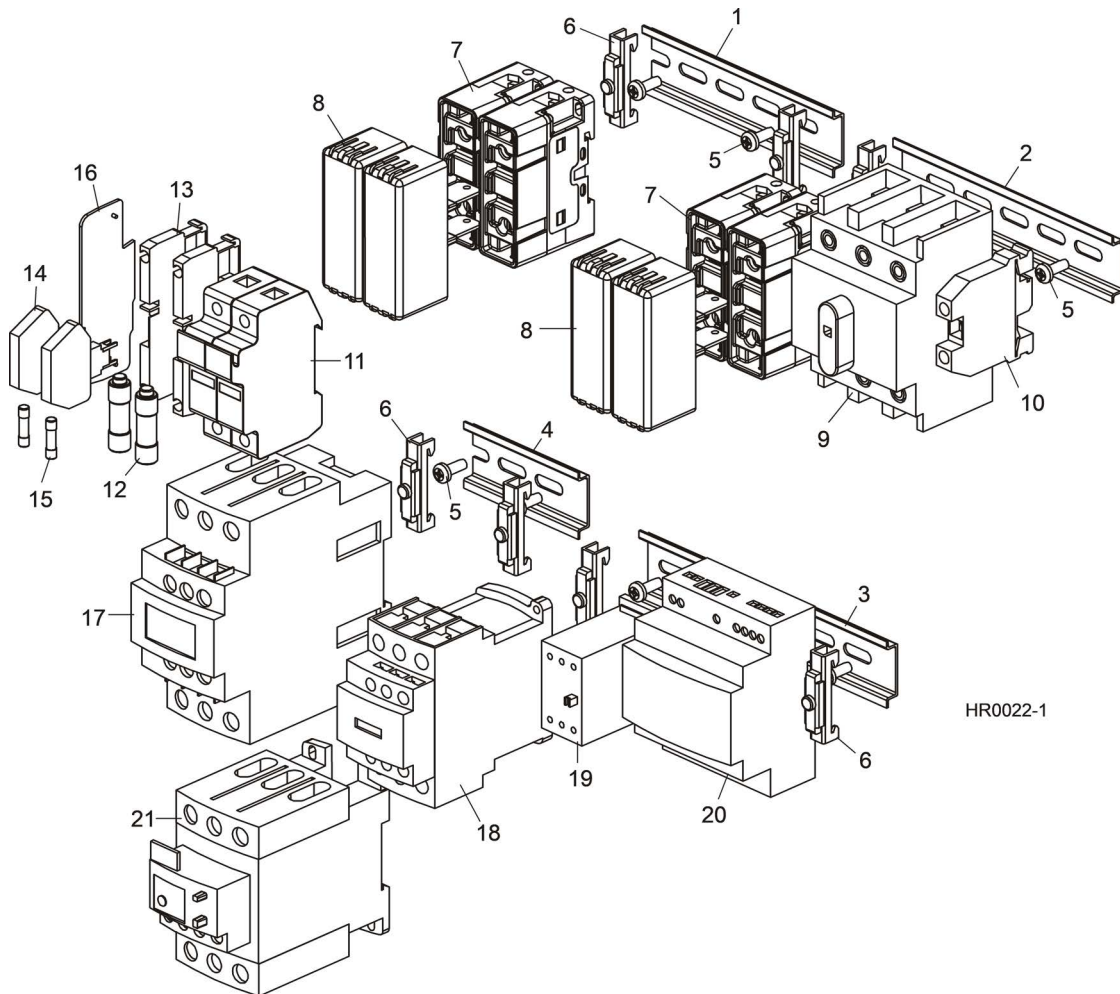

REF	PART #	DESCRIPTION	COMMENTS	QTY.
1	024474	DIN RAIL, 35MM X 7.5MM X 1M STEEL SYMMETRICAL		.069 Ft.
2	024474	DIN RAIL, 35MM X 7.5MM X 1M STEEL SYMMETRICAL		.080 Ft.
3	024474	DIN RAIL, 35MM X 7.5MM X 1M STEEL SYMMETRICAL		.090 Ft.
4	024474	DIN RAIL, 35MM X 7.5MM X 1M STEEL SYMMETRICAL		.042 Ft.
5	F05015-17	SCREW, #10-24 X 1/2" PHILLIPS PAN HEAD TYPE 23		8
6	E22707	CLAMP, PLASTIC DIN RAIL		7
7	053586	FUSEHOLDER, 100A CUBE		4
8	053587	FUSE, 80A CLASS J CUBE		4
9	050906-1	DISCONNECT, 100A 3PH NON-FUSED	5mm Disconnect Shaft OXP5X265 replaced by vendor with 6mm shaft OXP6X290 (2/10). Replacement of any disconnect component requires replacement of dis- connect, shaft and operator handle (050906-1, 050907-1 & 050908-1).	1
10	053585	TERMINAL BLOCK, GROUNDING		1
11	052512	FUSE BLOCK, 2P CLASS CC 30A DIN		1

REF	PART #	DESCRIPTION	COMMENTS	QTY.
12	052721	FUSE, 3.5A 600V CLASS CC DELAY		2
13	053562	TERMINAL BLOCK, 2P NO CONNECT		2
14	053497	TERMINAL BLOCK, 5X20MM FUSEHOLDER		2
15	050889	FUSE, 2A TIME LAG 5X20MM (PKG 10)		2 Pk.
16	053563	END CAP, NO CONNECT TERMINAL BLOCK		1
17	053604 ²	CONTACTOR, 65A 3P 24VDC D-A SERIES	65A Contactor 053604 replaced 50A Contactor 053601 9/10 to provide adequate horsepower rating.	1
18	052465	CONTACTOR, 32A 3P 24VDC COIL		1
19	053590	RELAY, 12VDC 2NO CONTROL		1
20	053591	POWER SUPPLY, 24VDC 60W DIN MOUNT		1
21	053692 ³	RELAY, 37-50A CLASS 10 OVERLOAD	Overload Relay 053692 applies only to Rev. A1.00 with original blade motor without thermostats.	1

4.15 Control Insert Components (HR130EB15)

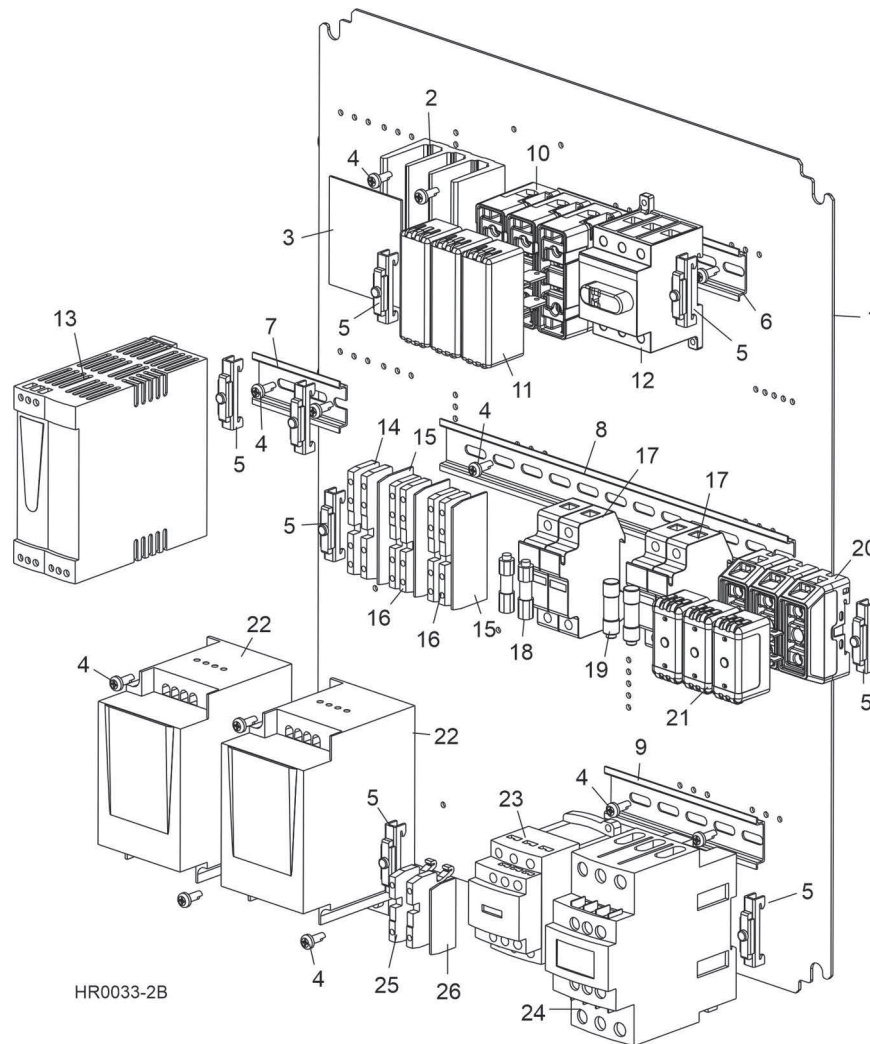

REF	PART #	DESCRIPTION	COMMENTS	QTY.
1	013968	PANEL, 14GA HR130 CONTROL INSERT		1
2	069701	DISTRIBUTION BLOCK, 3P 1 TO 4		1
3	069728	COVER, DISTRIBUTION BLOCK		1
4	F05015-17	SCREW, #10-24 X 1/2" PHILLIPS PAN HEAD TYPE 23		16
5	E22707	CLAMP, PLASTIC DIN RAIL		8
6	024474	DIN RAIL, 35MM X 7.5MM X 1M STEEL SYMMETRICAL		.087 Ft.
7	024474	DIN RAIL, 35MM X 7.5MM X 1M STEEL SYMMETRICAL		.042 Ft.
8	024474	DIN RAIL, 35MM X 7.5MM X 1M STEEL SYMMETRICAL		.167 Ft.
9	024474	DIN RAIL, 35MM X 7.5MM X 1M STEEL SYMMETRICAL		.073 Ft.
10	053586	FUSEHOLDER, 100A CUBE		3
11	069707	FUSE, 70A CLASS J CUBE		3
12	050881-1	DISCONNECT, 63A 600V 3PH 6MM SHAFT		1
13	069703	POWER SUPPLY, 24VDC 5A 110/230		1
14	053534	TERMINAL BLOCK, 4 POSITION GROUNDING		2
15	053535	END CAP, 4X TERMINAL BLOCK		3
16	053536	TERMINAL BLOCK, 4 POSITION COMMON		4
17	052512	FUSE BLOCK, 2P CLASS CC 30A DIN		2

REF	PART #	DESCRIPTION	COMMENTS	QTY.
18	E22716	FUSE, 2A 600V CLASS CC		2
19	052456	FUSE, 6A 600V CLASS CC DELAY		2
20	053717	FUSEHOLDER, 60A CUBE		3
21	069708	FUSE, 60A CLASS J CUBE		3
22	069704	AC DRIVE, ATV12 0.25HP 230V 1PH-3PH		2
23	024890	CONTACTOR, 9A 3P 24VDC COIL		1
24	053601	CONTACTOR, 50A 3P 24VDC D-A SERIES		1
25	053550	TERMINAL BLOCK, 2 POSITION		2
26	053551	END CAP, 2X TERMINAL BLOCK		1

4.16 Control Insert Components (HR130EC15)

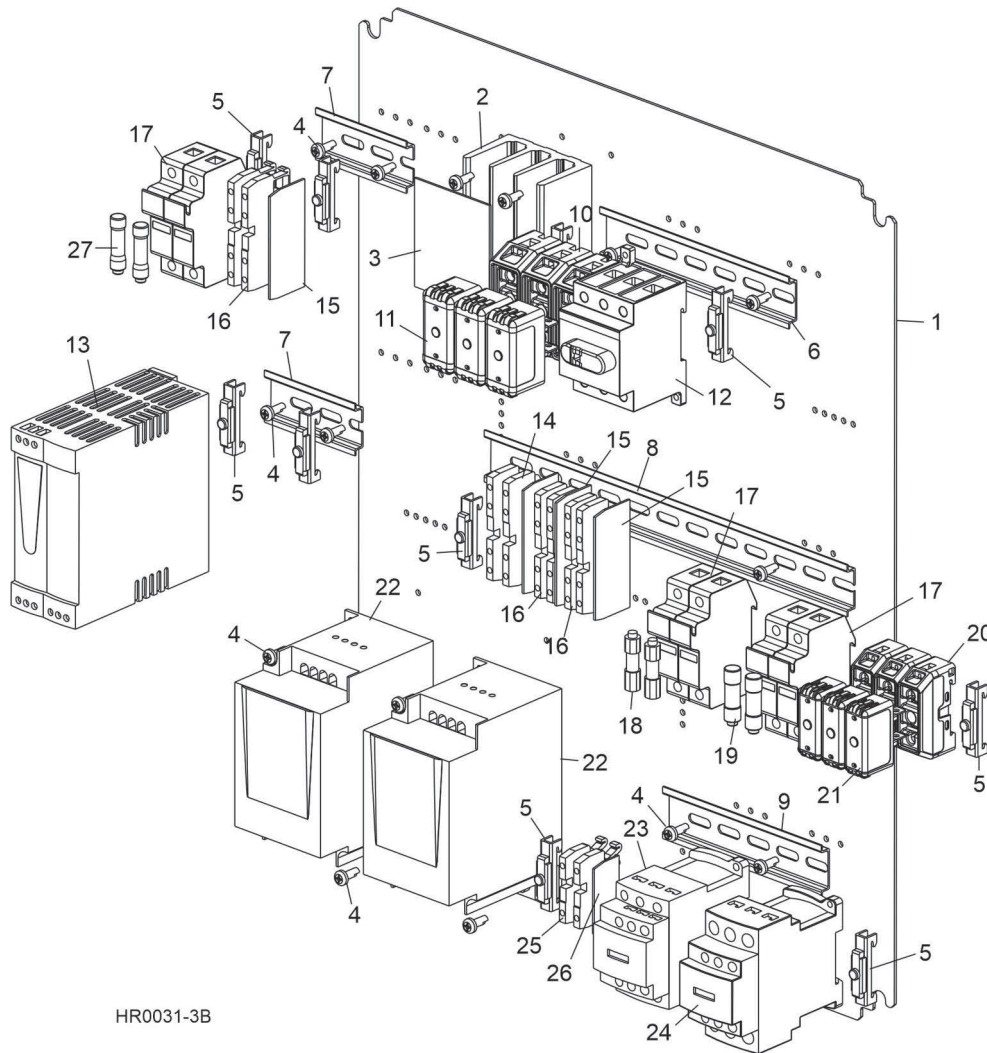

HR0031-3B

REF	PART #	DESCRIPTION	COMMENTS	QTY.
1	013968	PANEL, 14GA HR130 CONTROL INSERT		1
2	069701	DISTRIBUTION BLOCK, 3P 1 TO 4		1
3	069728	COVER, DISTRIBUTION BLOCK		1
4	F05015-17	SCREW, #10-24 X 1/2" PHILLIPS PAN HEAD TYPE 23		18
5	E22707	CLAMP, PLASTIC DIN RAIL		10
6	024474	DIN RAIL, 35MM X 7.5MM X 1M STEEL SYMMET- RICAL		.087 Ft.
7	024474	DIN RAIL, 35MM X 7.5MM X 1M STEEL SYMMET- RICAL		.042 Ft.
8	024474	DIN RAIL, 35MM X 7.5MM X 1M STEEL SYMMET- RICAL		.167 Ft.
9	024474	DIN RAIL, 35MM X 7.5MM X 1M STEEL SYMMET- RICAL		.073 Ft.
10	053717	FUSEHOLDER, 60A CUBE		3
11	069702	FUSE, 40A CLASS J CUBE		3
12	050881-1	DISCONNECT, 63A 600V 3PH 6MM SHAFT		1
13	069703	POWER SUPPLY, 24VDC 5A 110/230		1
14	053534	TERMINAL BLOCK, 4 POSITION GROUNDING		2

REF	PART #	DESCRIPTION	COMMENTS	QTY.
15	053535	END CAP, 4X TERMINAL BLOCK		4
16	053536	TERMINAL BLOCK, 4 POSITION COMMON		6
17	052512	FUSE BLOCK, 2P CLASS CC 30A DIN		3
18	E22716	FUSE, 2A 600V CLASS CC		2
19	052456	FUSE, 6A 600V CLASS CC DELAY		2
20	053736	FUSEHOLDER, 30A CUBE		3
21	053737	FUSE, 30A CLASS J CUBE		3
22	069704	AC DRIVE, ATV12 0.25HP 230V 1PH-3PH		2
23	024890	CONTACTOR, 9A 3P 24VDC COIL		1
24	051322	CONTACTOR, 25A 3P 24VDC COIL		1
25	053550	TERMINAL BLOCK, 2 POSITION		2
26	053551	END CAP, 2X TERMINAL BLOCK		1
27	051957	FUSE, 10A 600V CLASS CC DELAY		2

SECTION 5 UP/DOWN SYSTEM

5.1 Saw Head Lift (HR120)

HR120Rev. A1.01+

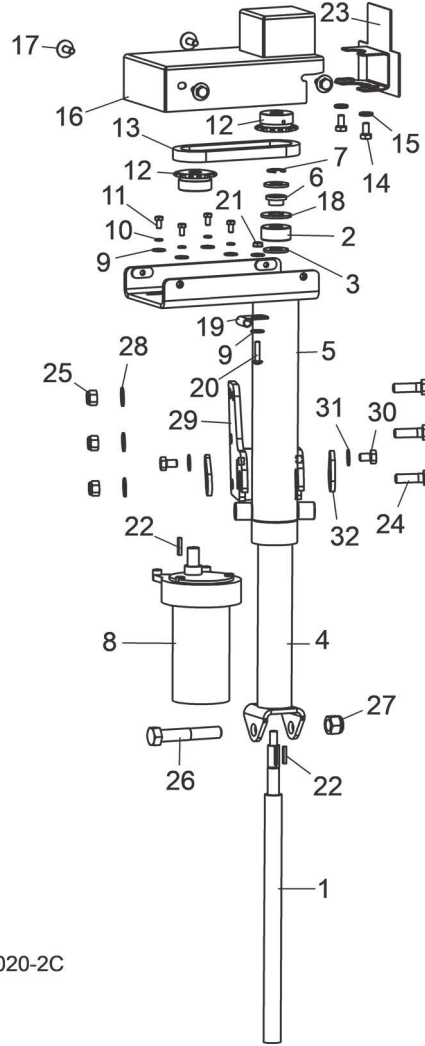

HR0020-2C

REF	PART #	DESCRIPTION	COMMENTS	QTY.
	074142	LIFT ASSEMBLY, HR120 SAW HEAD	Replaces 063147 Saw Head Lift Assembly including 007669 Saw Head Lift Upper Tube Weldment (Rev. A4.00). Previously, saw head lift assembly redesigned to improve durability (Rev. A3.00). 025706 Shaft replaced 007668 Saw Head Lift Shaft, 065767 Motor replaced 053577 HR120 Up/Down Motor Assembly, 101332-2 sprocket (2) replaced 063159 (1) and 063160 (1) sprockets, 025751 chain replaced 063188 #25 x 13 1/4" Roller Chain w/P09983 #25 Master Link, 025755 cover replaced 007671 Lift Drive Chain Cover, 036803 key replaced F05012-34 1/8" x 1" Roll Pin (2), added 065056 cover and cover fasteners.	1
1	025706	Shaft, HR Lift w/Setworks		1
2	063156	Bearing, 1/2" Thrust		1
3	F05011-2	Washer, 1/2" SAE Flat		2
4	063149	Tube Weldment, Saw Head Lift Base		1
5	074141	Tube Weldment, HR Lift		1
6	049007	Bushing, 1/2" ID x 5/8" OD x 3/8" Long Flanged		1
7	P10649	E-Clip, 1/2" Shaft		1
8	065767	Motor, 1/15HP 62RPM 12VDC 53:1 Gear		1
9	F05011-18	Washer, #10 SAE Flat		6
10	F05011-20	Washer, #10 Split Lock		4
11	F05004-60	Bolt, #10-32 x 1/2" Hex Head		4
12	101332-2	Sprocket, 35B14 x 1/2" Bore w/Set Screws		2
13	025751	Chain, #35 x 35 Pitches w/Master Link		1
14	F05005-15	Bolt, 1/4-20 x 1/2" Hex Head		2
15	F05011-14	Washer, 1/4" Split Lock		2
16	025755	Cover Weldment, HR130 Up/Down		1
17	F05005-134	Bolt, 1/4-20 x 3/4" Conical Washer Head		4
18	F05011-5	Washer, 5/8" SAE Flat		1
19	024155	Clamp, 1/4" Wire w/13/32" Mounting Hole		1
20	F05004-33	Screw, #10-24 x 7/8" Slotted Round Head		1
21	F05010-14	Nut, #10-24 Self-Locking Hex		1
22	036803	Key, 1/8" x 1/8" x 3/4"		2
23	065056	Cover, Encoder Mount		1
24	F05007-123	BOLT, 3/8-16 X 1 1/4" HEX HEAD		3
25	F05010-10	NUT, 3/8-16 HEX NYLON LOCK		3
26	F05008-23	BOLT, 1/2-13 X 3" HEX HEAD GRADE 5		1
27	F05010-8	NUT, 1/2-13 HEX NYLON LOCK		1
28	F05011-3	WASHER, 3/8" SAE FLAT		3
29	074137	LIFT WELDMENT, UPPER HR		1
30	F05006-15	BOLT, 5/16-18 X 1/2" HEX HEAD GRADE 5		2
31	F05011-17	WASHER, 5/16" SAE FLAT		2
32	074189	PLATE, LIFT RETAINER		2

5.2 Saw Head Lift (HR120)

HR120Rev. A1.00

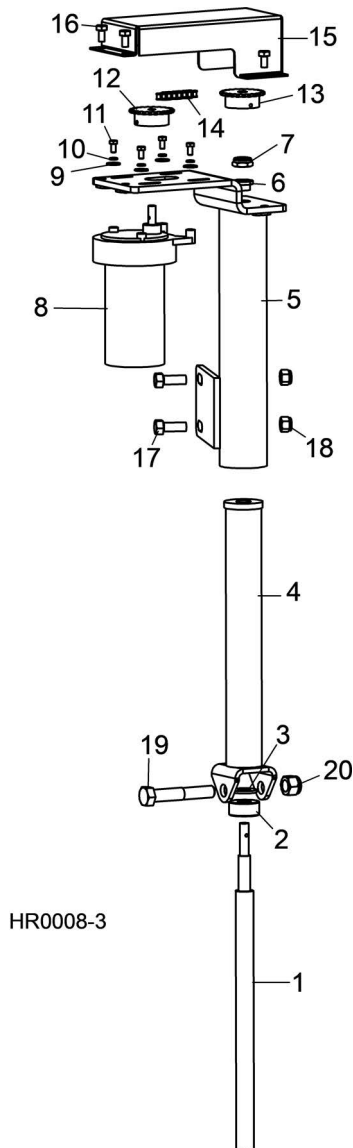

HR0008-3

REF	PART #	DESCRIPTION	COMMENTS	QTY.
	063147	LIFT ASSEMBLY, SAW HEAD		1
1	063155	Shaft, Saw Head Lift		1
2	063156	Bearing, 1/2" Thrust		1
3	F05011-2	Washer, 1/2" SAE Flat		1
4	063149	Tube Weldment, Saw Head Lift Base		1
5	063148	Tube Weldment, Saw Head Lift Upper		1
6	049007	Bushing, 1/2" ID x 5/8" OD x 3/8" Long Flanged		1
7	F05010-127	Nut, 1/2-13 Hex Half Nylon Lock		1
8	053577	Motor Assembly, HR120 Up/Down		1
9	F05011-18	Washer, #10 SAE Flat		4
10	F05011-20	Washer, #10 Split Lock		4
11	F05004-60	Bolt, #10-32 x 1/2" Hex Head		4

REF	PART #	DESCRIPTION	COMMENTS	QTY.
12	063159	Sprocket, 25B22 x 5/16" Modified		1
13	063160	Sprocket, 25B22 x 3/8" Modified		1
14	063188	Chain, #25 x 13 1/4" Roller		1
15	063178	Cover, Lift Drive Chain		1
16	F05005-15	Bolt, 1/4-20 x 1/2" Hex Head		3
17	F05007-7	BOLT, 3/8-16 X 1" HEX HEAD		2
18	F05010-10	NUT, 3/8-16 HEX NYLON LOCK		2
19	F05008-23	BOLT, 1/2-13 X 3" HEX HEAD GRADE 5		1
20	F05010-8	NUT, 1/2-13 HEX NYLON LOCK		1

5.3 Saw Head Lift (HR130)

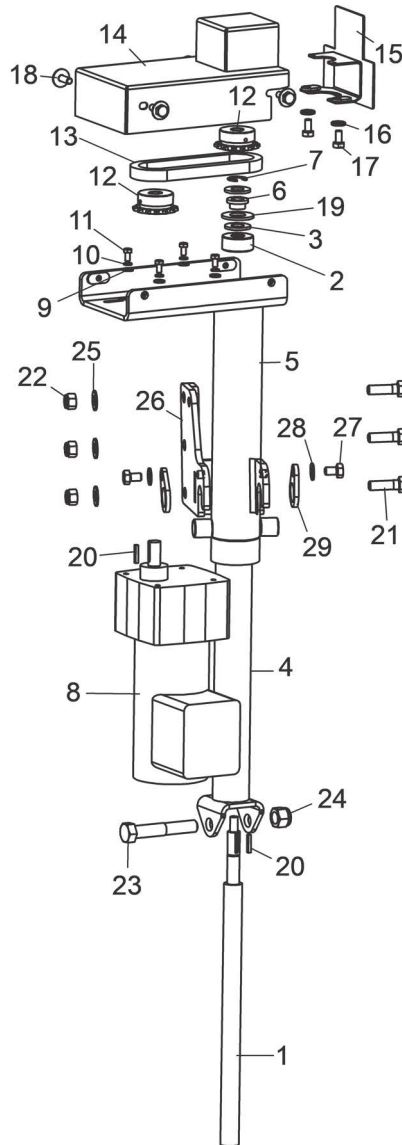

HR0036-3C

REF	PART #	DESCRIPTION	COMMENTS	QTY.
	074143	LIFT ASSEMBLY, HR130 SAW HEAD	Replaces 025695 Saw Head Lift Assembly including 007669 Saw Head Lift Upper Tube Weldment (Rev. A3.00).	1
1	025706	Shaft, Saw Head Lift		1
2	063156	Bearing, 1/2" Thrust		1
3	F05011-2	Washer, 1/2" SAE Flat		2
4	063149	Tube Weldment, Saw Head Lift Base		1
5	074141	Tube Weldment, HR Lift		1
6	049007	Bushing, 1/2" ID x 5/8" OD x 3/8" Long Flanged		1
7	P10649	E-Clip, 1/2" Shaft		1
8	025696	Motor, 1/15HP 57RPM 230V 3PH 30:1 Gear		1
9	F05011-18	Washer, #8 SAE Flat		4
10	F05011-20	Washer, #10 Split Lock		4
11	F05004-60	Bolt, #10-32 x 1/2" Hex Head		4
12	101332-2	Sprocket, 35B14 x 1/2" Bore w/Set Screw		2

REF	PART #	DESCRIPTION	COMMENTS	QTY.
13	025751	Chain, #35 x 35 Pitch w/Master Link		1
14	025755	Cover Weldment, HR130 Lift Drive Chain	Cover Weldment 025755 modified (Rev. A2.01) to two-piece cover to accommodate setworks option. If setworks added to previous revision HR130, order parts 025755, 065056, two F05011-14 and two F05005-15.	1
15	065056	Cover Weldment, Encoder Mount		1
16	F05011-14	Washer, 1/4" Split Lock		2
17	F05005-15	Bolt, 1/4-20 x 1/2" Hex Head		2
18	F05005-134	Bolt, 1/4-20 x 3/4" Conical Washer Head		4
19	F05011-5	Washer, 5/8" SAE Flat		1
20	036803	Key, 1/8" Square x 3/4"		2
21	F05007-123	BOLT, 3/8-16 X 1 1/4" HEX HEAD		3
22	F05010-10	NUT, 3/8-16 HEX NYLON LOCK		3
23	F05008-23	BOLT, 1/2-13 X 3" HEX HEAD GRADE 5		1
24	F05010-8	NUT, 1/2-13 HEX NYLON LOCK		1
25	F05011-3	WASHER, 3/8" SAE FLAT		3
26	074137	LIFT WELDMENT, UPPER HR		1
27	F05006-15	BOLT, 5/16-18 X 1/2" HEX HEAD GRADE 5		2
28	F05011-17	WASHER, 5/16" SAE FLAT		2
29	074189	PLATE, LIFT RETAINER		2

5.4 Saw Head Mount & Blade Height Scale

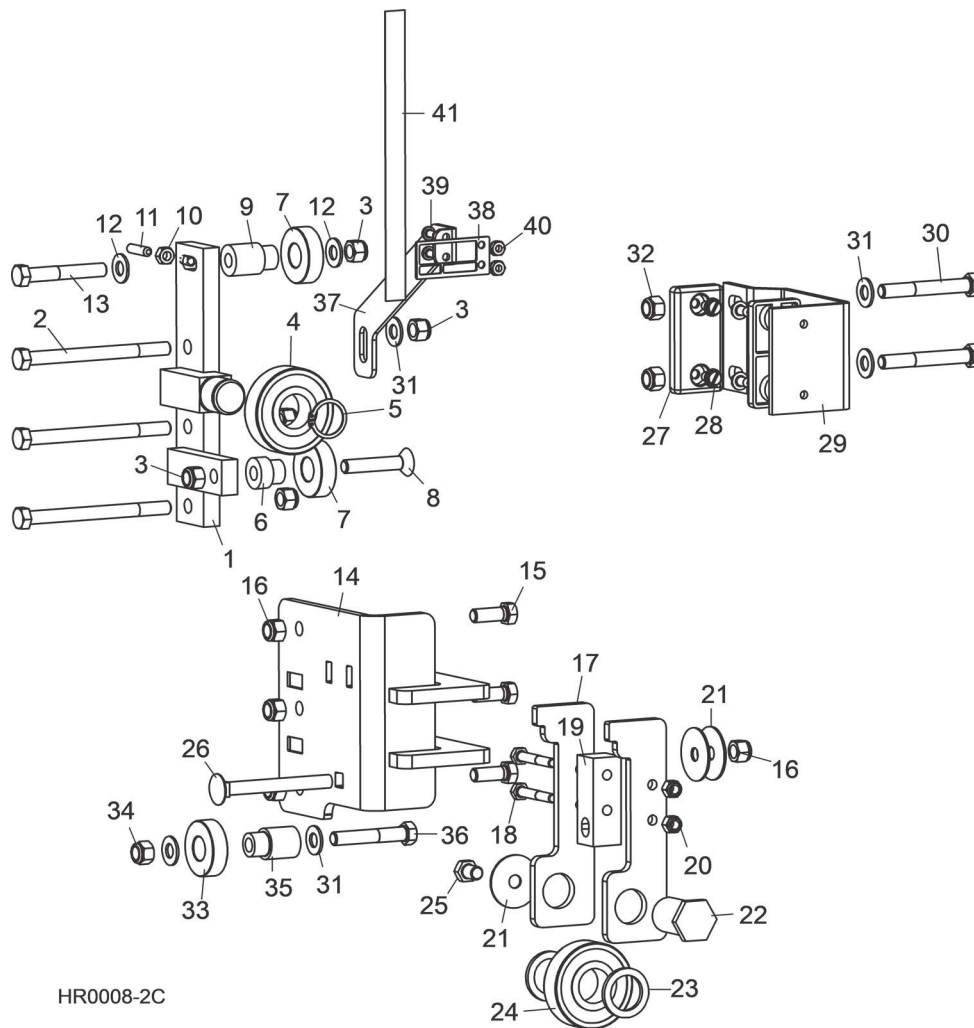

HR0008-2C

REF	PART #	DESCRIPTION	COMMENTS	QTY.
	046885	BEARING ASSEMBLY, SAW HEAD MOUNT UPPER	Modified to improve contact between roller bearings and up/down tube (HR120 Rev. A4.03/HR130 Rev. A4.02). Modifications include adding new parts as listed in parts table and removing (1) 014932 Saw Head Mount Bearing Shaft, (1) F04254-2 5/8" 5100-62 OR Ring, (1) P06030-1 5/8" x 1.7548" x .4724" Bearing and (1) F05007-87 3/8-16 x 1" Hex Head Bolt from top mount hole of upper bearing assembly.	1
1	046635	Bracket Weldment, Upper Saw Head Mount		1
2	F05007-35	Bolt, 3/8-16 x 4 1/2" Hex Head		3
3	F05010-10	Nut, 3/8-16 Hex Nylon Lock		5
4	P08066	Bearing, .9843" x 2.4409" x .6693"		1
5	F04254-26	Ring, 25mm 5100-98 OR		1
6	046608	Bushing, Saw Head Mount Bearing		1
7	P06030-2	Bearing, 6203-2NSL 17mm SRI-2 ABEC-1		2
8	F05007-198	Bolt, 3/8-16 x 2" Flat Socket Head		1

REF	PART #	DESCRIPTION	COMMENTS	QTY.
9	074748	Spacer, Bearing		1
10	F05010-63	Nut, 1/4-20 Free		1
11	F05005-2	Screw, 1/4-20 x 1" SH Cup Pt Set		1
12	F05011-3	Washer, 3/8" SAE Flat		2
13	F05007-125	Bolt, 3/8-16 x 2 1/2" Hex Head Grade 5		1
	046886	BEARING ASSEMBLY, SAW HEAD MOUNT LOWER		1
14	046969	Bracket Weldment, Lower Saw Head Mount		1
15	F05007-97	Bolt, 3/8-16 x 1" Hex Head Grade 5		3
16	F05010-10	Nut, 3/8-16 Hex Nylon Lock		4
17	046604	Plate, Bearing Cam		2
18	046607	Block, Bearing Spacer		1
19	F05005-68	Bolt, 1/4-20 x 1 3/4" Hex Head Grade 5		2
20	F05010-69	Nut, 1/40-20 Hex Nylon Lock		2
21	F05011-44	Washer, 3/8" Fender		3
22	046606	Shaft, Bearing Mount		1
23	046974	Washer, Spacer		2
24	P08066	Bearing, .9843" x 2.4409" x .6693"		1
25	F05004-124	Bolt, 3/8-16 x 1/2" Hex Head Grade 5		1
26	F05007-161	Bolt, 3/8-16 x 3 1/2" Carriage Head		1
27	P13576	PAD, IDLE SIDE SLIDE		2
28	F05015-1	BOLT, 1/4-20 X 1/2" SLOTTED HEX HEAD		4
29	014905	BRACKET, IDLE SIDE SLIDE PAD MOUNT		1
30	F05007-29	BOLT, 3/8-16 X 2 3/4" HEX HEAD		2
31	F05011-3	WASHER, 3/8" SAE FLAT		4
32	F05010-10	NUT, 3/8-16 HEX NYLON LOCK		2
33	F05011-3	WASHER, 3/8" FLAT		1
34	F05010-10	NUT, 3/8-16 HEX NYLON LOCK		1
35	074748	SPACER, BEARING		1
36	F05007-201	BOLT, 3/8-16 X 2-1/4" HEX HEAD GRADE 5		1
37	046963	BRACKET, BLADE HEIGHT POINTER MOUNT	HR120	1
	017805	BRACKET, BLADE HEIGHT POINTER MOUNT	HR130	1
38	017805	POINTER, BLADE HEIGHT		1
39	F05004-3	SCREW, #10-24 X 3/8" PHILLIPS PAN HEAD		2
40	F05010-14	NUT, #10-24 SELF-LOCKING HEX		2
41	007653	DECAL, HR100 SERIES BLADE HEIGHT SCALE		1

SECTION 6 CONVEYOR BELT FEED SYSTEM

6.1 Feed Belt Conveyor (HR120)

Rev. A2.00+

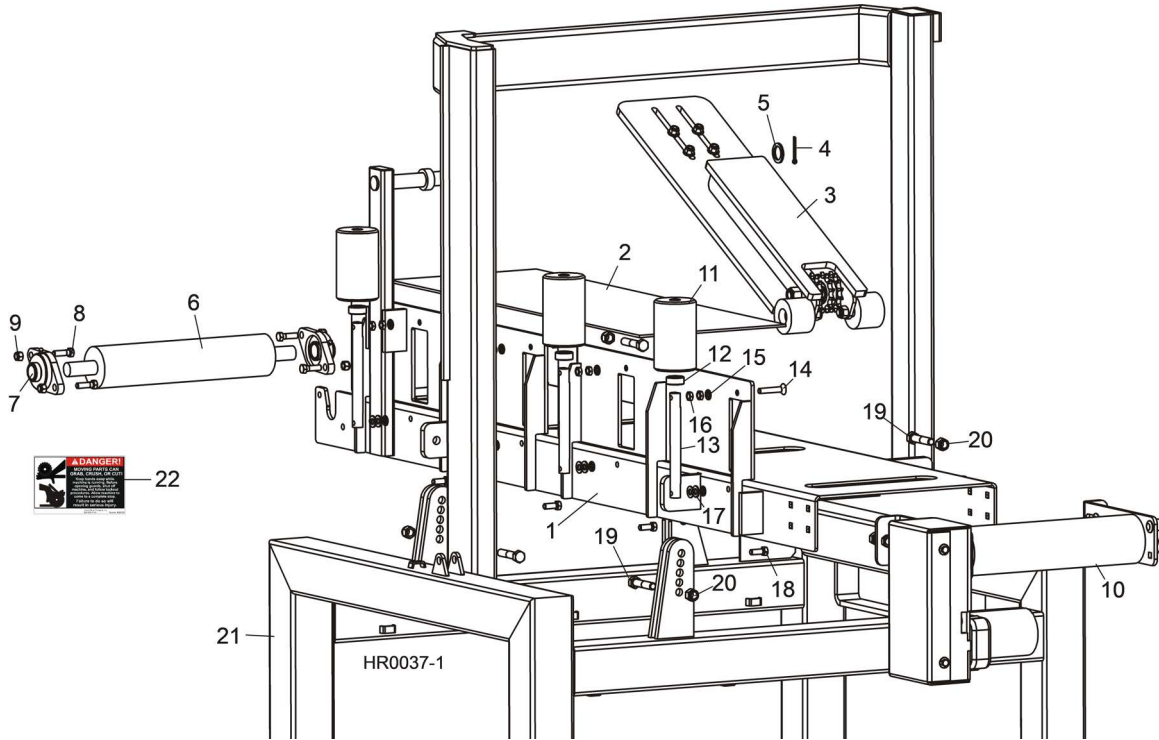

REF	PART #	DESCRIPTION	COMMENTS	QTY.
	063103	CONVEYOR ASSEMBLY, HR120 FEED BELT		1
1	063109	Frame Weldment, HR100 Series Conveyor		1
2	063175	Belt, 12" x 154" Rough Top Laced	(See Section 6.9) for optional shingle belt	1
	061189	Pin, Conveyor Belt .065	(See Section 6.5)	14
3		Hold-Down Parts		
4	F05012-23	Pin, 3/16" x 1 1/2" Cotter		1
5	046974	Washer, Spacer		1
6	063121	Pulley, 3" x 14" Crowned		1
7	038124	Bearing, 1" Flanged VF2S 216		2
8	F05007-123	Bolt, 3/8-16 x 1 1/4" Hex Head Grade 5		4
9	F05010-10	Nut, 3/8-16 Hex Nylon Lock		4
10		Belt Drive Parts	(See Section 6.6)	
	025770	Roller Assembly, HR100 Series Side		4
11	062447	Roller, Side		1
12	P04146	Collar, 3/4" ID Lock		1
13	062448	Shaft, Side Roller Mount		1
14	F05007-198	Screw, 3/8-16 x 2" Flat Socket Head		1
15	F05011-4	Washer, 3/8" Split Lock		2
16	F05010-29	Nut, 3/8-16 Hex Jam		2
17	F05011-3	Washer, 3/8" SAE Flat		2

REF	PART #	DESCRIPTION	COMMENTS	QTY.
18	F05007-82	Bolt, 3/8-16 x 1" Hex Head Grade 8		1
19	F05008-74	BOLT, 1/2-13 X 2 1/2 HEX HEAD GRADE 5		4
20	F05010-8	NUT, 1/2-13 HEX NYLON LOCK		4
21	063105	TABLE WELDMENT, HR100 SERIES RESAW		1
22	028720	DECAL, MOVING PARTS DANGER		2

6.2 Feed Belt Conveyor (HR120)

After 4/10 - Rev. A1.01

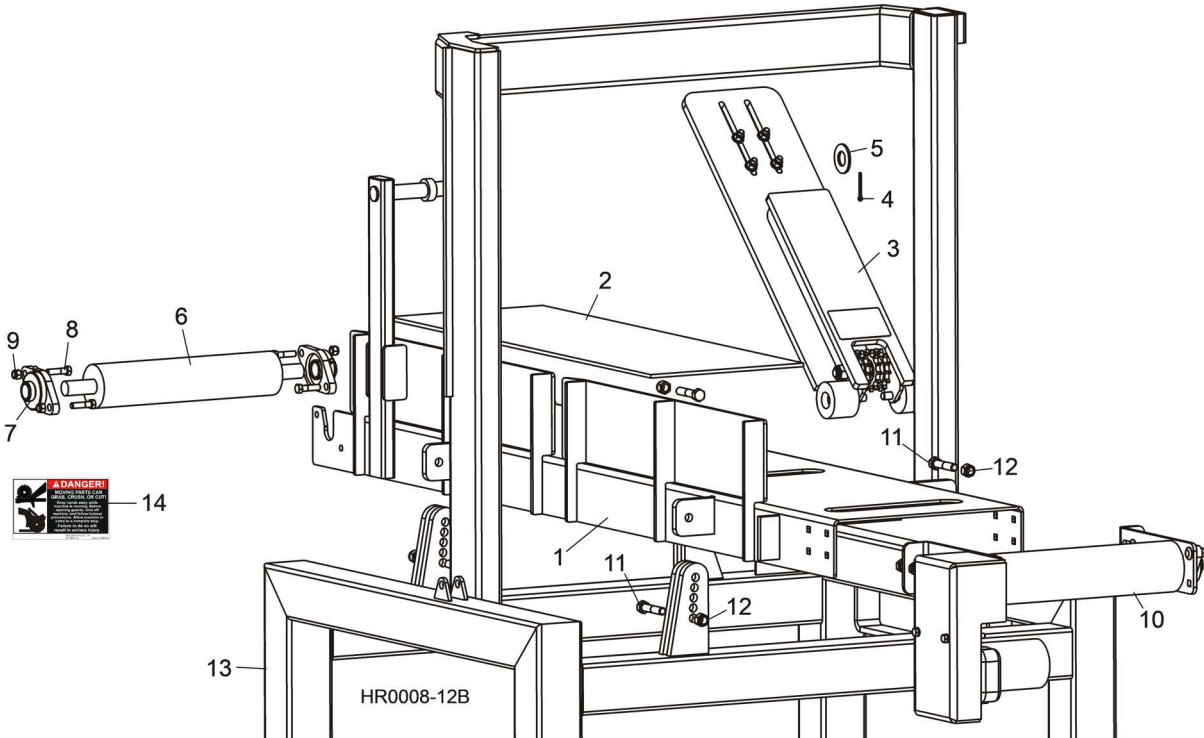

6.3 Feed Belt Conveyor (HR120)

REF	PART #	DESCRIPTION	COMMENTS	QTY.
	063103	CONVEYOR ASSEMBLY, HR120 FEED BELT	Conveyor Assembly 063103 modified Rev. A2.00 to include side roller assemblies (See Section 6.1).	1
1	063109	Frame Weldment, HR100 Series Conveyor		1
2	063175	Belt, 12" x 154" Rough Top Laced (for optional shingle belt)	(See Section 6.6)	1
	061189	Pin, Conveyor Belt .065		14
3		Hold-Down Parts ()	(See Section 6.3)	
4	F05012-23	Pin, 3/16" x 1 1/2" Cotter		1
5	046974	Washer, Spacer		1
6	063121	Pulley, 3" x 14" Crowned		1
7	038124	Bearing, 1" Flanged VF2S 216		2
8	F05007-123	Bolt, 3/8-16 x 1 1/4" Hex Head Grade 5		4
9	F05010-10	Nut, 3/8-16 Hex Nylon Lock		4
10		Belt Drive Parts ()	(See Section 6.4)	
11	F05008-74	BOLT, 1/2-13 X 2 1/2 HEX HEAD GRADE 5		4
12	F05010-8	NUT, 1/2-13 HEX NYLON LOCK		4
13	063105	TABLE WELDMENT, HR100 SERIES RESAW		1
14	028720	DECAL, MOVING PARTS DANGER		2

Before 4/10

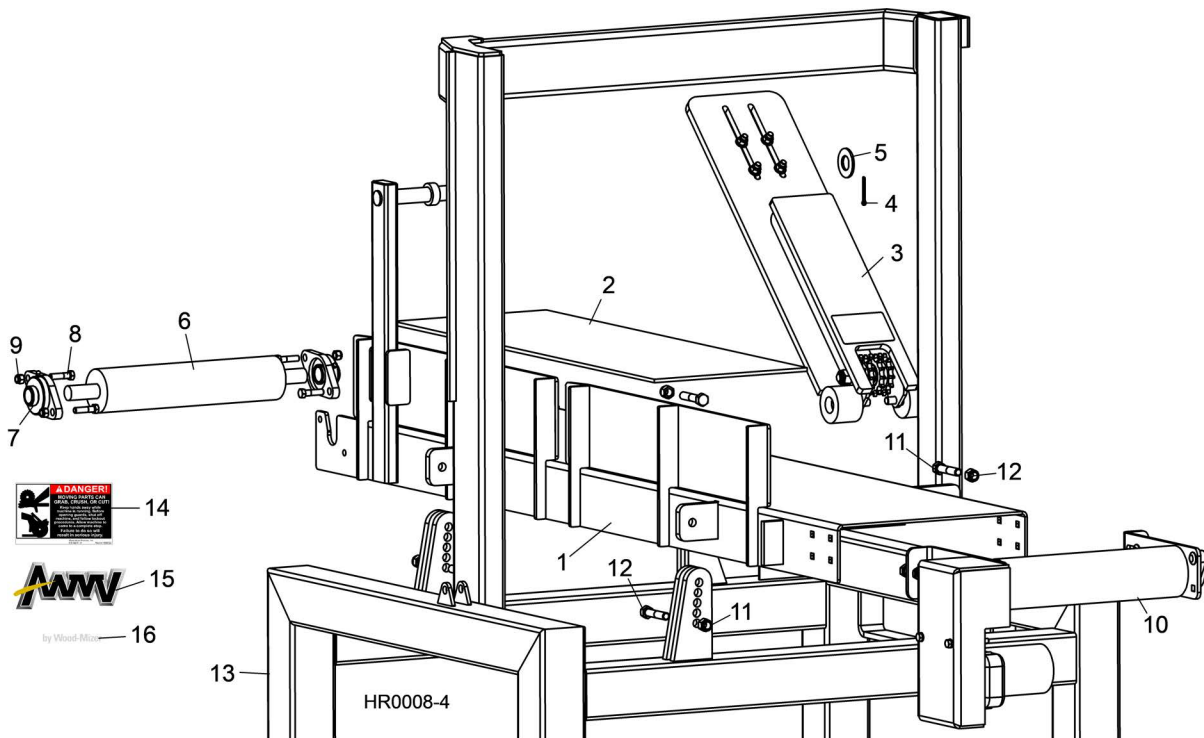

6 Conveyor Belt Feed System

Feed Belt Conveyor (HR120)

REF	PART #	DESCRIPTION	COMMENTS	QTY.
	063103	CONVEYOR ASSEMBLY, HR120 FEED BELT	Conveyor Assembly 063103 modified 8/10 to include side roller assemblies (See Section 6.1).	1
1	063109	Frame Weldment, HR120 Conveyor	Slots added to prevent sawdust from building up between the belt and the conveyor plate (2/10).	1
2	063175	Belt, 12" x 154" Rough Top Laced ((See Section 6.6) for optional shingle belt)		1
	061189	Pin, Conveyor Belt .065		14
3		Hold-Down Parts ((See Section 6.3))		
4	F05012-23	Pin, 3/16" x 1 1/2" Cotter		1
5	F05011-28	Washer, 1" SAE Flat		1
6	063121	Pulley, 3" x 14" Crowned		1
7	038124	Bearing, 1" Flanged VF2S 216		2
8	F05007-78	Bolt, 3/8-16 x 1 1/2" Hex Head Grade 5		4
9	F05010-10	Nut, 3/8-16 Hex Nylon Lock		4
10		Belt Drive Parts ((See Section 6.4))		
11	F05008-74	Bolt, 1/2-13 x 2 1/2 Hex Head Grade 5		4
12	F05010-8	Nut, 1/2-13 Hex Nylon Lock		4
13	063105	TABLE WELDMENT, HR120 RESAW		1
14	028720	DECAL, MOVING PARTS DANGER		2
15	052416	DECAL, AWMV LOGO 6"		2
16	059506	DECAL, BY WOOD-MIZER FOR 6" AWMV LOGO		2

6.4 Feed Belt Conveyor (HR130)

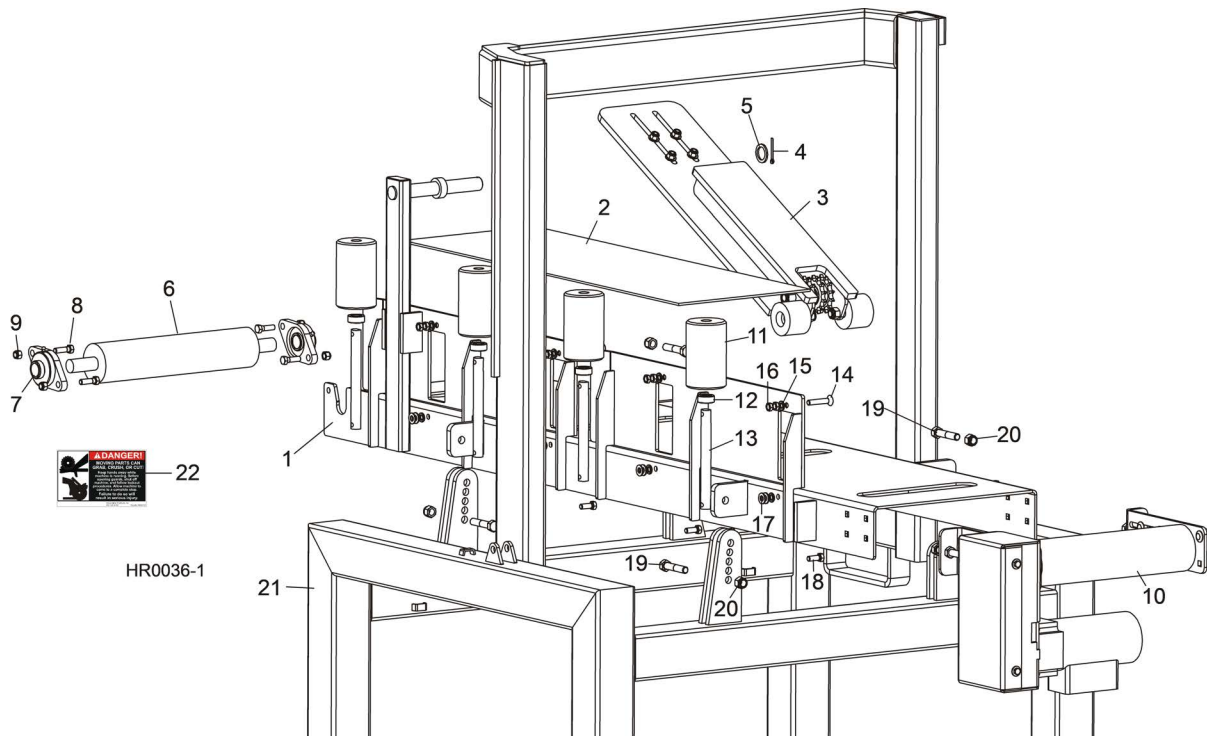

REF	PART #	DESCRIPTION	COMMENTS	QTY.
	025693	CONVEYOR ASSEMBLY, HR130 FEED BELT		1
1	063109	Frame Weldment, HR100 Series Conveyor		1
2	063175	Belt, 12" x 154" Rough Top Laced	(See Section 6.9) for optional shingle belt	1
	061189	Pin, Conveyor Belt .065		14
3		Hold-Down Parts	(See Section 6.5)	
4	F05012-23	Pin, 3/16" x 1 1/2" Cotter		1
5	046974	Washer, Spacer		1
6	063121	Pulley, 3" x 14" Crowned		1
7	038124	Bearing, 1" Flanged VF2S 216		2
8	F05007-123	Bolt, 3/8-16 x 1 1/4" Hex Head Grade 5		4
9	F05010-10	Nut, 3/8-16 Hex Nylon Lock		4
10		Belt Drive Parts	(See Section 6.8)	
	025770	Roller Assembly, HR100 Series Side		4
11	062447	Roller, Side		1
12	P04146	Collar, 3/4" ID Lock		1
13	062448	Shaft, Side Roller Mount		1
14	F05007-198	Screw, 3/8-16 x 2" Flat Socket Head		1
15	F05011-4	Washer, 3/8" Split Lock		2
16	F05010-29	Nut, 3/8-16 Hex Jam		2
17	F05011-3	Washer, 3/8" SAE Flat		2
18	F05007-82	Bolt, 3/8-16 x 1" Hex Head Grade 8		1
19	F05008-74	BOLT, 1/2-13 X 2 1/2 HEX HEAD GRADE 5		4
20	F05010-8	NUT, 1/2-13 HEX NYLON LOCK		4
21	063105	TABLE WELDMENT, HR100 SERIES RESAW		1
22	028720	DECAL, MOVING PARTS DANGER		2

6.5 Hold-Down Assembly

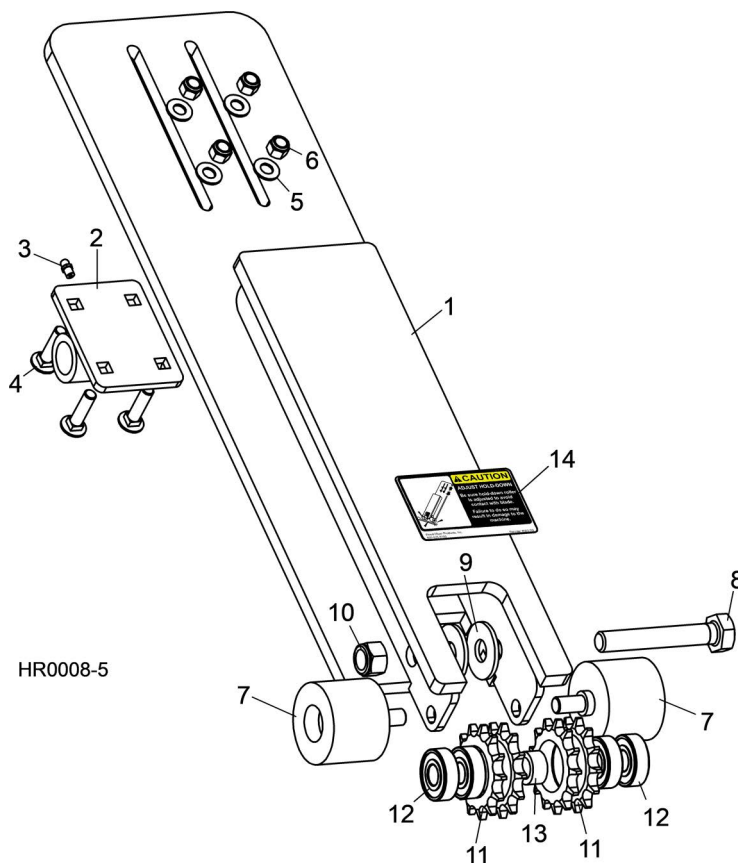

REF	PART #	DESCRIPTION	COMMENTS	QTY.
	063137	HOLD DOWN ASSY, CANT	HR120, HR130	1
1	063132	Box Weldment, Cant Hold-Down		1
2	063162	Pivot Weldment, Cant Hold-Down		1
3	P05060	Fitting, 1/4-28 Grease		1
4	F05007-85	Bolt, 3/8-16 x 1 1/2" Carriage Head Grade 5		4
5	F05011-3	Washer, 3/8" SAE Flat		4
6	F05010-10	Nut, 3/8-16 Hex Nylon Lock		4
7	063135	Roller, Cant Hold-Down		2
8	F05009-31	Bolt, 5/8-11 x 4 Hex Head Full Thread Grade 5		1
9	F05011-40	Washer, 5/8" Standard Flat		2
10	F05010-34	Nut, 5/8-11 Hex Nylon Lock		1
	016019	Sprocket Assy, #50-2 Idler		2
11	015202	Sprocket, D50B13 Modified		1
12	P06030-1	Bearing, 5/8" ID x 1.7548" OD x .4724"		2
13	063169	Spacer, 5/8" ID x 1" OD x .5"		1
14	063189	DECAL, ADJUST HOLD-DOWN CAUTION		1

6.6 Conveyor Feed Assembly (HR120)

HR120Rev. A1.01+

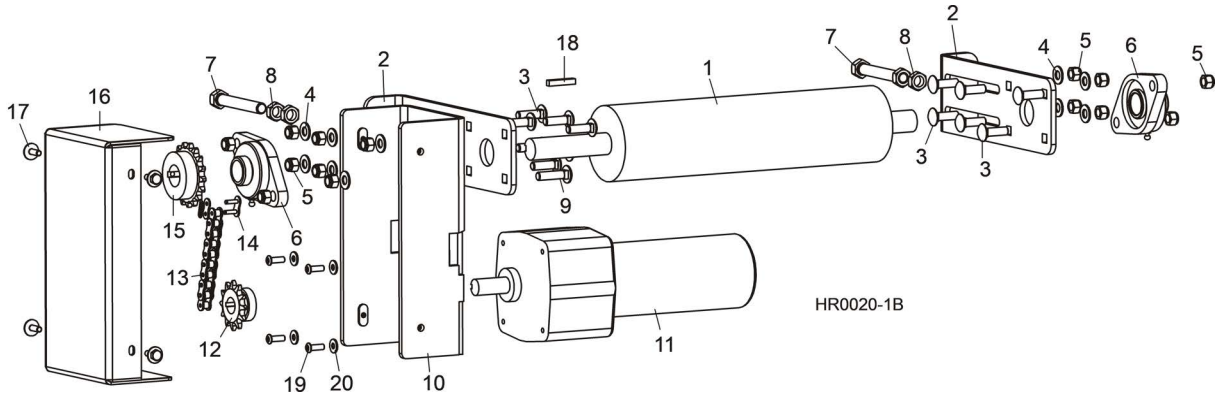

REF	PART #	DESCRIPTION	COMMENTS	QTY.
1	063122	PULLEY 3" X 14" LAGGED		1
2	063125	PLATE, ROLLER TENSION		2
3	F05007-127	BOLT, 3/8-16 X 1 1/4" CARRIAGE HEAD GRADE 5		12
4	F05011-3	WASHER, 3/8" SAE FLAT		10
5	F05010-10	NUT, 3/8-16 HEX NYLON LOCK		14
6	038124	BEARING, 1" FLANGED VF2S 216		2
7	F05008-111	BOLT, 1/2-20 X 3 3/4" HEX HEAD FULL THREAD GRADE 5		2
8	F05010-16	NUT, 1/2-20 HEX JAM		4
9	F05007-85	BOLT, 3/8-16 X 1 1/2" CARRIAGE HEAD GRADE 5		2
10	065734	MOUNT WELDMENT, FEED MOTOR	065734 Mount Weldment replaced 007605 Feed Motor Mount Plate Weldment and 065735 Motor replaced 053578 Feed Motor Assembly to improve motor durability (Rev. A3.00). Use 065756 HR120 Gear Motor Kit for service (Rev. A3.00). Upgrade kit 065804 including 1/4HP gearmotor assembly, motor mount, hex head bolts and flat washers is available for upgrade (Rev. A1.01 - A2.03).	1
11	065735 ¹	MOTOR, 12V X 1/4HP GEAR 43:1 FEED		1
	061294	Brush Kit, Feed Motor HR120		1
12	101795	SPROCKET, 40B12 X 3/4" BORE		1
13	063184	CHAIN, #40 X 40 PITCH		1
14	P04200	LINK, #40 MASTER		1
15	003883	SPROCKET, 40B17 X 1" BORE		1
16	007606	COVER WELDMENT, FEED DRIVE		1
17	F05005-134	BOLT, 1/4-20 X 3/4" CONICAL WASHER HEAD		4
18	017832	KEY, 1/4" SQUARE X 1 3/8"		1

6 **Conveyor Belt Feed System**
Conveyor Feed Assembly (HR120)

REF	PART #	DESCRIPTION	COMMENTS	QTY.
19	F05005-73	BOLT, 1/4-28 X 3/4" HEX HEAD GRADE 5		4
20	F05011-11	WASHER, 1/4" SAE FLAT		4

6.7 Conveyor Feed Assembly (HR120)

HR120Rev. A1.00

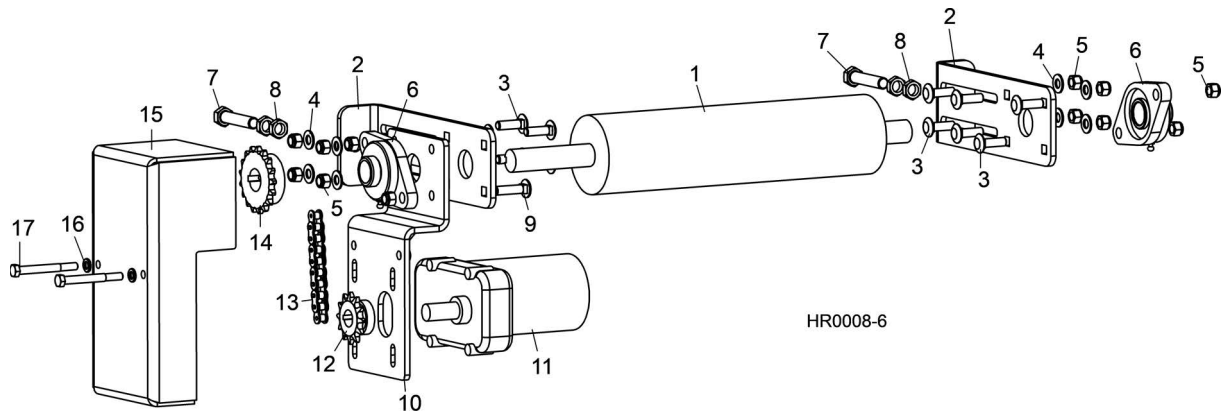

REF	PART #	DESCRIPTION	COMMENTS	QTY.
1	063122	PULLEY 3" X 14" LAGGED		1
2	063125	PLATE, ROLLER TENSION		2
3	F05007-127	BOLT, 3/8-16 X 1 1/4" CARRIAGE HEAD GRADE 5		10
4	F05011-3	WASHER, 3/8" SAE FLAT		8
5	F05010-10	NUT, 3/8-16 HEX NYLON LOCK		12
6	038124	BEARING, 1" FLANGED VF2S 216		2
7	F05008-135	BOLT, 1/2-20 X 2 1/2" HEX HEAD FULL THREAD GRADE 5		2
8	F05010-16	NUT, 1/2-20 HEX JAM		4
9	F05007-85	BOLT, 3/8-16 X 1 1/2" CARRIAGE HEAD GRADE 5		2
10	063170	PLATE WELDMENT, FEED MOTOR MOUNT		1
11	053578	MOTOR ASSEMBLY, HR120 FEED	Gearmotor and motor mount replaced Rev. A3.00 to improve motor durability (See Section 6.6). Upgrade kit 065804 including 1/4HP gearmotor assembly, motor mount, hex head bolts and flat washers is available for upgrade.	1
	065182	Brush Kit, Klauber 33:1 Gearmotor Endbell		1
12	101795	SPROCKET, 40B12 X 3/4" BORE		1
13	063184	CHAIN, #40 X 40 PITCH		1
14	003884	SPROCKET, 40B17 X 1 1/4" BORE		1
15	063171	COVER WELDMENT, FEED DRIVE		1
16	F05011-13	WASHER, 5/16" SPLIT LOCK		2
17	F05006-62	BOLT, 5/16-18 X 3" HEX HEAD GRADE 5		2

6.8 Conveyor Drive Assembly (HR130)

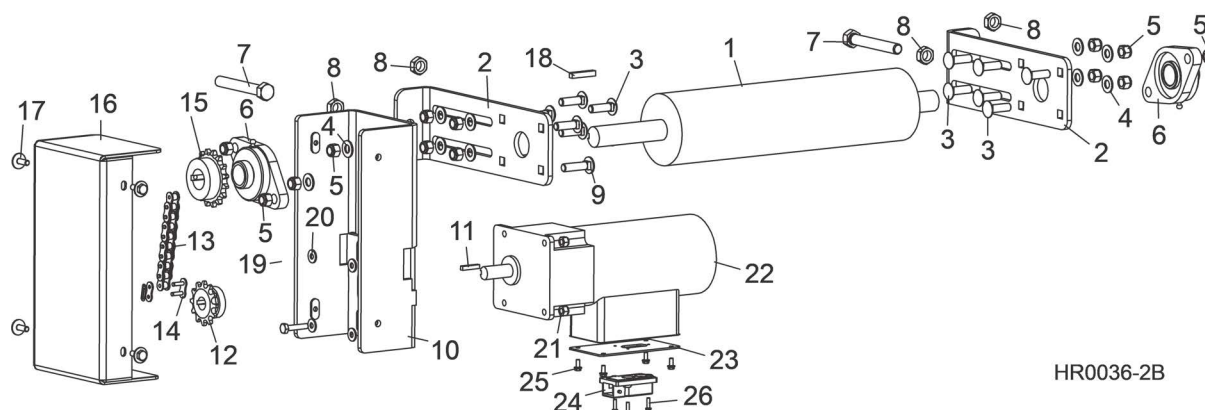

HR0036-2B

REF	PART #	DESCRIPTION	COMMENTS	QTY.
1	063122	PULLEY 3" X 14" LAGGED		1
2	063125	PLATE, ROLLER TENSION		2
3	F05007-127	BOLT, 3/8-16 X 1 1/4" CARRIAGE HEAD GRADE 5		12
4	F05011-3	WASHER, 3/8" SAE FLAT		10
5	F05010-10	NUT, 3/8-16 HEX NYLON LOCK		14
6	038124	BEARING, 1" FLANGED VF2S 216		2
7	F05008-135	BOLT, 1/2-20 X 2 1/2" HEX HEAD FULL THREAD GRADE 5		2
8	F05010-16	NUT, 1/2-20 HEX JAM		4
9	F05007-85	BOLT, 3/8-16 X 1 1/2" CARRIAGE HEAD GRADE 5		2
10	007605	PLATE WELDMENT, FEED MOTOR MOUNT		1
11	S31027	KEY, 3/16" SQUARE X 1"		1
12	025704	SPROCKET, 40B12 X 5/8" BORE		1
13	063184	CHAIN, #40 X 39 PITCH (19 1/2")		1
14	P04200	LINK, #40 MASTER		1
15	007311	SPROCKET, 40B16 X 1" BORE		1
16	007606	COVER WELDMENT, FEED DRIVE		1
17	F05005-134	BOLT, 1/4-20 X 3/4" CONICAL WASHER HEAD		4
18	017832	KEY, 1/4" SQUARE X 1 3/8"		1
19	F05005-3	BOLT, 1/4-20 X 1 1/4" FULL THREAD HEX HEAD		4
20	F05011-11	WASHER, 1/4" SAE FLAT		4
21	F05010-69	NUT, 1/4-20 HEX NYLON LOCK		4
	073702	MOTOR ASSEMBLY, HR130 FEED CONVEYOR	Introduced to make it easy to disconnect conveyor feed motor for shipping purposes (Rev. A4.03).	1
22	025702	Motor, 1/6HP 90RPM 230V 3PH 19:1 Gear		1
23	076752	Plate, HR130 Motor Connector Mount		1
24	073706	Connector, 3+PE 6-10mm Cable OD Male		1
25	F05015-8	Bolt, #8-32 x 3/8" Self Tap		4
26	F05015-28	Screw, #6-32 x 1/2" Plain PH T23		3

6.9 Shingle Belt Assembly (Optional)

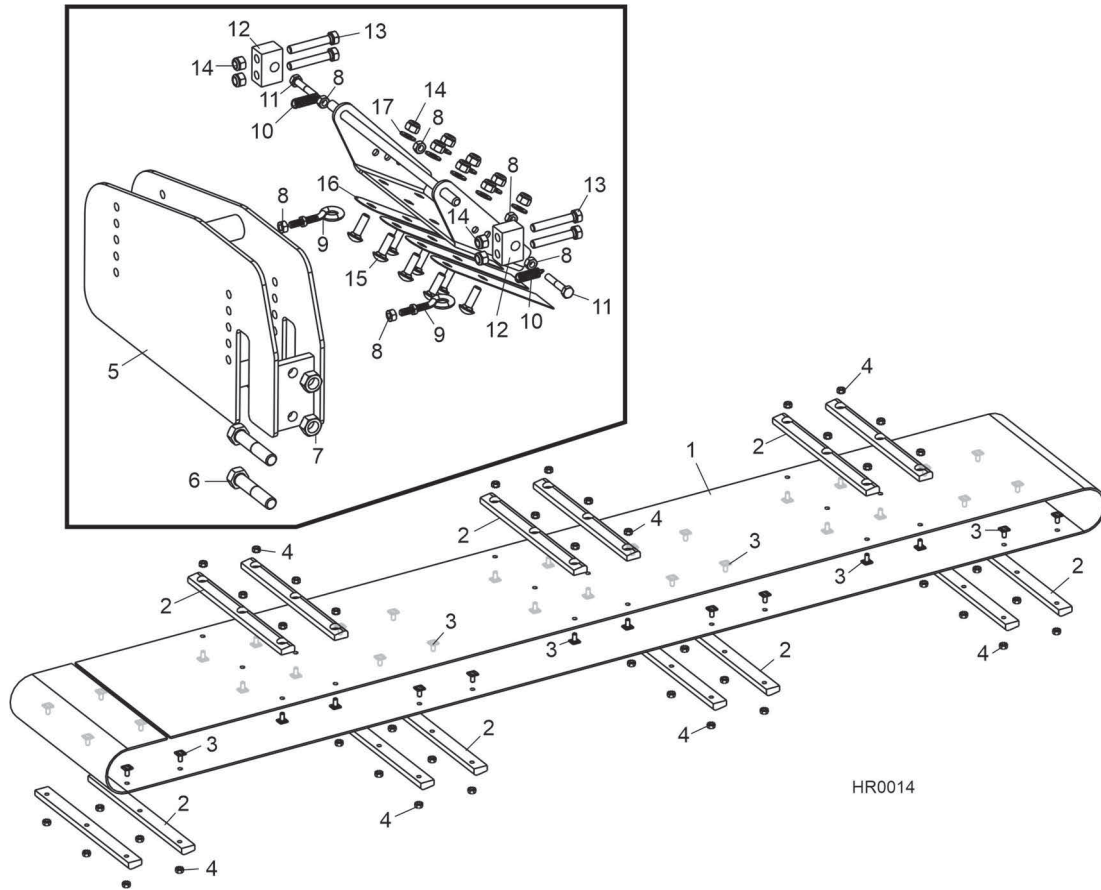

HR0014

REF	PART #	DESCRIPTION	COMMENTS	QTY.
	HR120-SB	BELT ASSEMBLY, HR100 SERIES SHINGLE		1
1	063191	Belt, 12" Wide PVC		1
2	059366	Bar, Shingle Catch		14
3	007616	Stud, 1/4-20 x 1/2" Base Plate		42
4	F05010-9	Nut, 1/4-20 Self-Locking Hex		42
	059549	Hold-Down Assembly, HR100 Series Shingle		1
5	059547	Bracket Weldment, HR100 Series Shingle Stop		1
6	F05008-74	Bolt, 1/2-13 x 2 1/2" Hex Head Grade 5		2
7	F05010-35	Nut, 1/2-13 Hex		2
8	F05010-63	Nut, 1/4-20 Hex		6
9	007673	Bolt, 1/4-20 x 1 1/2" Eye w/Nut		2
10	046645	Spring, .375" OD x 1.25" Extension		2
11	F05005-5	Bolt, 1/4-20 x 1 1/2" Hex Head		2
12	059535	Block, Hold-Down Pivot		2
13	F05006-13	Bolt, 5/16-18 x 2" Hex Head Full Thread		4
14	F05010-59	Nut, 5/16-18 Hex Nylon Lock		12
15	F05006-9	Bolt, 5/16-18 x 1" Carriage Head Stainless		8
16	059552	Plate, Shingle Hold-Down Strap		4
17	F05011-17	Washer, 5/16" SAE Flat		8

SECTION 7 ENGINE ASSEMBLY

7.1 Engine (G19)

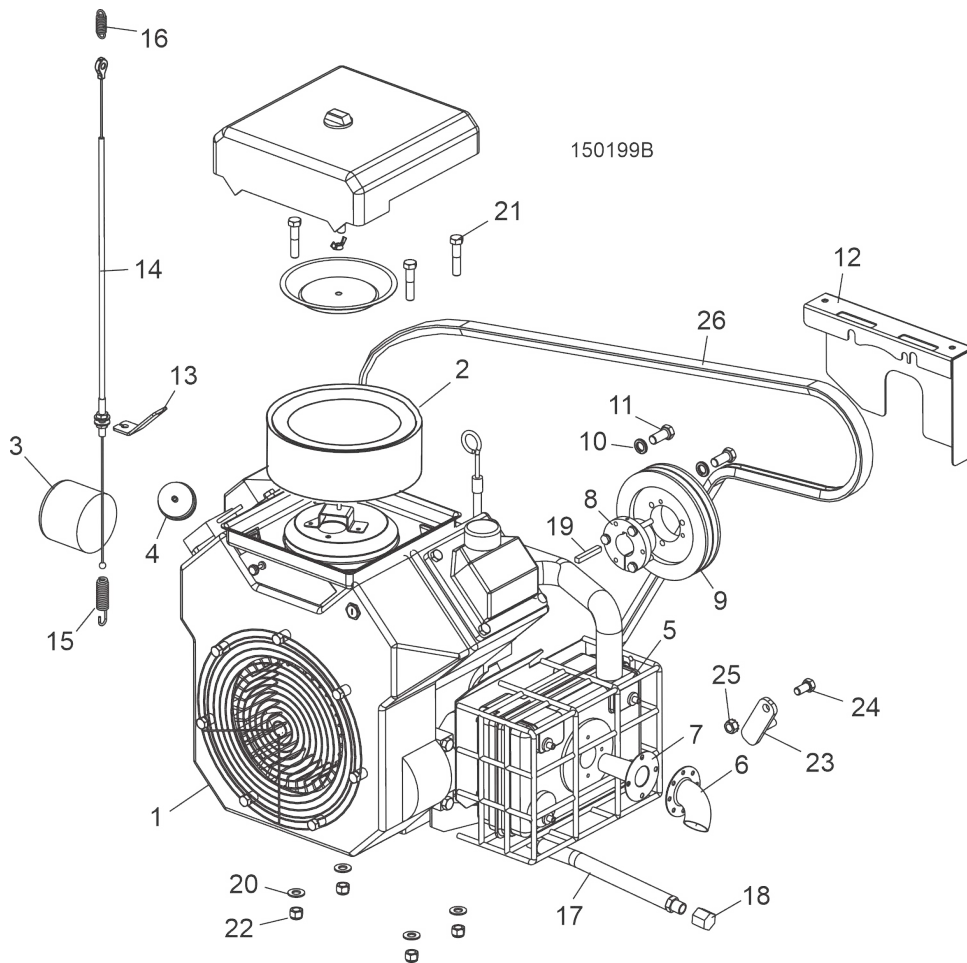

REF	PART #	DESCRIPTION	COMMENTS	QTY.
	065191	ENGINE ASSEMBLY, HR120/LT15 G19		1
1	016899	Engine, 19Hp Kohler CH18		1
2	141022	Filter, 19hp Kohler Air&PreClnr Kit		1
	006907	Plug, Kohler Spark #12-132-02	006907 and 006931 combined	2
	061370	Module Kit, Kohler Ignition #KH24 584 45S (Qty. 2)		1
	048391	Pump, Kohler Fuel #24-393-16S		1
	061150	Switch, Kohler Ignition #25-099-37S		1
3	065264	Filter, Kohler Oil #12 050 01S		1
4	P12758	Filter, Kohler Fuel #24-050-13		1
5	065193	Muffler Assembly, Kohler		1
6	016495	Deflector, Kohler Muffler #12-755-28		1
7	016496	Arrestor, Kohler Spark #12-189-02		1
8	038432	Bushing, 1 1/8" SH		1
9	047742	Pulley, 3V5.6 x 2" SH		1
10	F05011-48	Washer, 7/16" Split Lock		2
11	F05007-145	Bolt, 7/16-14 x 1" Hex Head Grade 5		2
12	016493	Plate, Engine Guard		1

REF	PART #	DESCRIPTION	COMMENTS	QTY.
13	047750	Plate, Throttle Cable Mount		1
14	047749	Cable, LT15 G25 Throttle		1
15	016033	Spring, Throttle		1
16	015952	Spring, Throttle Extension		1
17	P10082	Hose, 3/8" NPT Oil Drain		1
18	P04332	Cap, Oil Drain Hose		1
19	S04124	Key, 1/4" x 1 11/16"		1
	024718	HARNES, BATTERY TO ENGINE		1
20	F05011-3	WASHER, 3/8" SAE FLAT		4
21	F05007-119	BOLT, 3/8-16 X 1 3/4" HEX HEAD GRADE 5		4
22	F05010-10	NUT, 3/8-16 HEX NYLON LOCK		4
23	048237	SUPPORT WELDMENT, DRIVE BELT		1
24	F05007-118	BOLT, 3/8-16 X 3/4" HEX HEAD GRADE 5		1
25	F05010-19	NUT, 3/8-16 SELF-LOCKING HEX		1
26	047751	BELT, 2/3VFL900 DRIVE (D17, D19 & G25 ONLY)		1

7.2 Engine (G25)

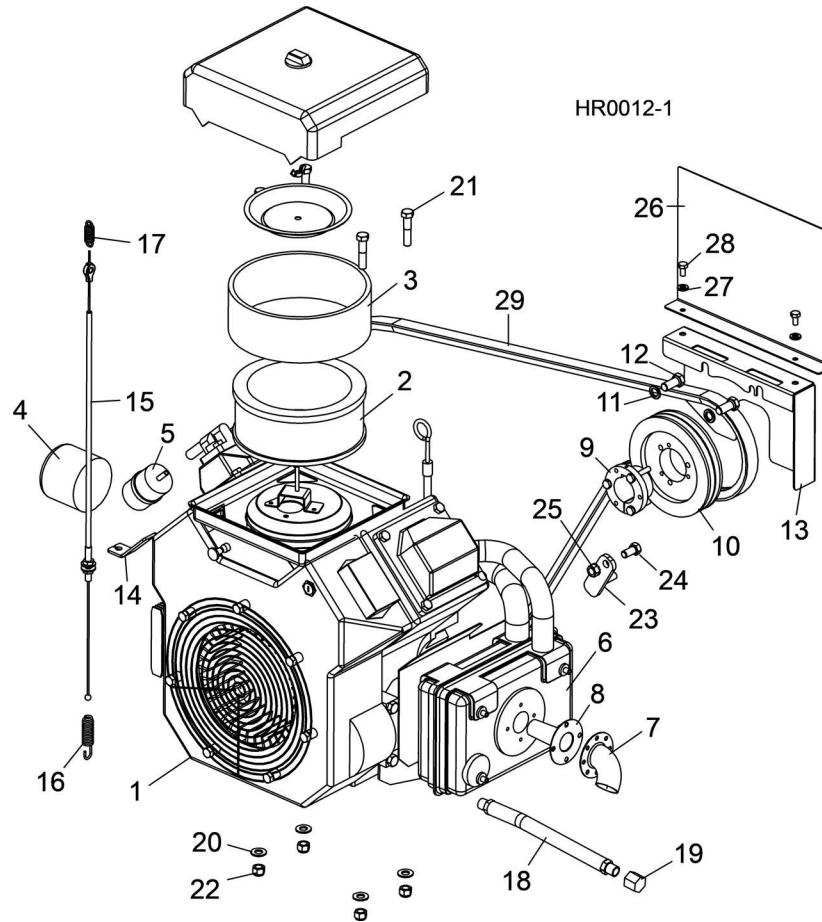

REF	PART #	DESCRIPTION	COMMENTS	QTY.
	015993	MANUAL, KOHLER CH25 OWNER'S		1
	015994	MANUAL, KOHLER CH25 SERVICE		1
	047740	ENGINE ASSEMBLY, G25		1
1	012832	Engine, 25Hp Kohler CH25 Spec PA 68600		1
	016290	Gasket Kit, Kohler CH25 Head #24-757-31		1
	P12734	Filter Kit, Kohler Air/Pre #24-883-03-S1		1
2	P12736	Filter, Kohler Air #24-083-03	Available in assemblies only.	1
3	P12737	Pre Cleaner, Kohler #24-083-05	Available in assemblies only.	1
	P12757	Plug, RC12YC Kohler Spark #12-132-02		2
	016079	Module Kit, Kohler Ignition #25-584-14-S		2
4	014717	Filter, Kohler Oil #52-050-02		1
5	P12758	Filter, Kohler Fuel #24-050-13		1
	061150	Switch, Ignition G19/25		1
6	051569	Muffler Assembly, Kohler #24-786-19		1
7	016495	Deflector, Kohler Muffler #12-755-28		1
8	016496	Arrestor, Kohler Spark #12-189-02		1
9	016535	Bushing, 1 7/16" SH		1
10	047742	Pulley, 3V5.6 x 2" SH		1
11	F05011-48	Washer, 7/16" Split Lock		2
12	F05007-145	Bolt, 7/16-14 x 1" Hex Head Grade 5		2

REF	PART #	DESCRIPTION	COMMENTS	QTY.
13	016493	Plate, Engine Guard		1
14	047750	Plate, Throttle Cable Mount		1
15	047749	Cable, LT15 G25 Throttle		1
16	016033	Spring, Throttle		1
17	015952	Spring, Throttle Extension		1
18	P10082	Hose, 3/8" NPT Oil Drain		1
19	P04332	Cap, Oil Drain Hose		1
	061303	SOLENOID, FUEL SHUT OFF 24-757-01-S		1
	024718	HARNESS, BATTERY TO ENGINE		1
20	F05011-3	WASHER, 3/8" SAE FLAT		4
21	F05007-119	BOLT, 3/8-16 X 1 3/4" HEX HEAD GRADE 5		4
22	F05010-10	NUT, 3/8-16 HEX NYLON LOCK		4
23	048237	SUPPORT WELDMENT, DRIVE BELT		1
24	F05007-118	BOLT, 3/8-16 X 3/4" HEX HEAD GRADE 5		1
25	F05010-19	NUT, 3/8-16 SELF-LOCKING HEX		1
26	063193	PLATE, AIR DEFLECTOR		1
27	F05011-14	WASHER, 1/4" SPLIT LOCK		2
28	F05005-15	BOLT, 1/4-20 X 1/2" HEX HEAD		2
29	047751	BELT, 2/3VFL900 DRIVE		1

7.3 Engine (D17)

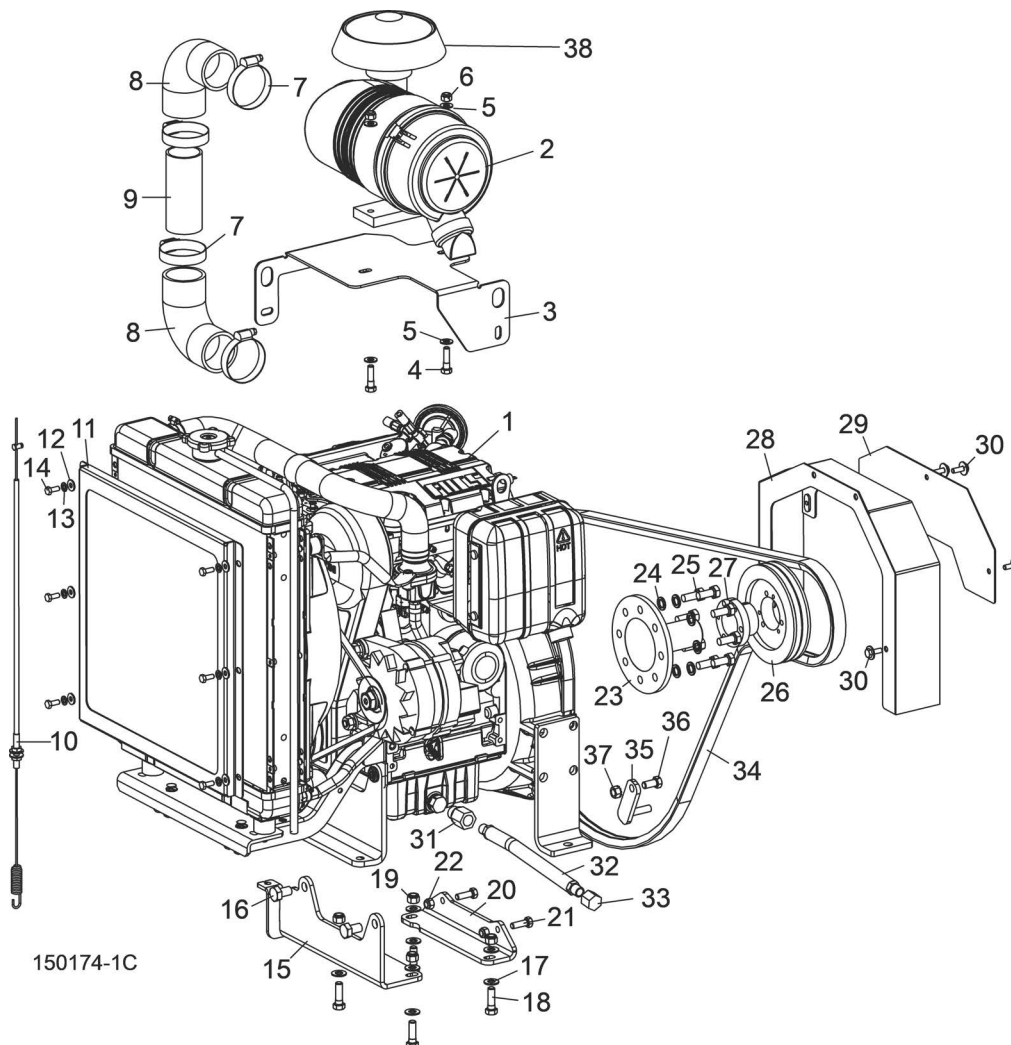

REF	PART #	DESCRIPTION	COMMENTS	QTY.
	007333	ENGINE ASSEMBLY, LT15 17HP DIESEL		1
1	007332	Engine, 17HP Kohler Diesel Model KDW702	Available in assemblies only.	1
2	007401	Filter Assembly, Kohler #ED0037004550-S		1
	007613	Filter, Kohler Secondary Air #ED0021751250-S		1
	007408	Filter, Kohler Primary Air #ED0021751240-S		1
	007614	Motor, Kohler Starter #ED0058402240-S		1
	065408	Alternator, Kohler 65A #ED0011572700-S	065408 replaces 014277 Kohler 14V 45A #ED0011573600-S Alternator and 065409 replaces 014212 Kohler Fan #ED0024403080-S Belt.	1
	065409	Belt, Kohler Fan #ED0024403160-S		1
	061187	Filter, Kohler/Lombardini Oil #ED0021752830-S		1
	061188	Filter, Kohler/Lombardini Fuel #ED0021752880-S		1
	014557	Switch Kit, Oil Pressure w/Gasket		1

REF	PART #	DESCRIPTION	COMMENTS	QTY.
	014279	Switch, Diesel Fuel Shut-Off		1
	014289	Pump, Diesel Fuel		1
	014278	Plug, Diesel Glow		2
3	062308	Bracket, Air Filter Mount		1
4	F05006-18	Bolt, 5/16-18 x 1 1/4" Hex Head Full Thread		2
5	F05011-17	Washer, 5/16" SAE Flat		4
6	F05010-20	Nut, 5/16-18 Self-Locking Hex		2
7	P09895	Clamp, 2 1/2" Hose		4
8	007394	Elbow, 90° x 2" ID Rubber		2
9	007395	Tube, 1 3/4" ID x 2" OD x 4"		1
10	007392	Cable, LT15 D17D17		1
11	007465	Guard Weldment, D17 Radiator		1
12	F05011-11	Washer, 1/4" SAE Flat		6
13	F05011-14	Washer, 1/4" Split Lock		6
14	F05004-219	Bolt, M6 x 1.0 x 16mm Hex Head		6
15	007427	Bracket Weldment, Rear D17 Mount		1
16	F05004-251	Bolt, M12 x 1.75 x 20mm Hex Head Full Thread		2
17	F05011-3	Washer, 3/8" SAE Flat		8
18	F05007-123	Bolt, 3/8-16 x 1 1/4" Hex Head Grade 5		4
19	F05010-10	Nut, 3/8-16 Hex Nylon Lock		4
20	007426	Bracket, D17 Front Mount		1
21	F05006-27	Bolt, 5/16-18 x 1" Hex Head Grade 5		2
22	F05010-58	Nut, 5/16-18 Hex Nylon Lock		2
23	014024	Shaft, Diesel Engine Drive		1
24	F05011-88	Washer, 10mm Split Lock		8
25	F81003-11	Bolt, M10-1.5 x 24mm Hex Head Grade 8.8		8
26	047742	Sheave, 3V5.6 x 2-SH		1
27	007338	Bushing, SH - 1 9/16"		1
28	007336	Guard Weldment, Motor Pulley		1
29	007344	Cover, Engine Pulley Guard		1
30	F05005-134	Bolt, 1/4-20 x 3/4" Hex w/Conical Washer Head		4
31	065163	Fitting, M18 x 3/8" NPT Adaptor		1
32	P10082	Hose, 3/8" NPT x 9 5/8" Rubber		1
33	P04332	Fitting, 3/8" Galvanized Pipe Cap		1
34	047751	BELT, 2/3VFL900 DRIVE		1
35	048237	SUPPORT WELDMENT, DRIVE BELT		1
36	F05007-118	BOLT, 3/8-16 X 3/4" HEX HEAD GRADE 5		1
37	F05010-19	NUT, 3/8-16 SELF-LOCKING HEX		1
	074947	PANEL, FRONT D17 YANMAR		1

7.4 Motor (E15)

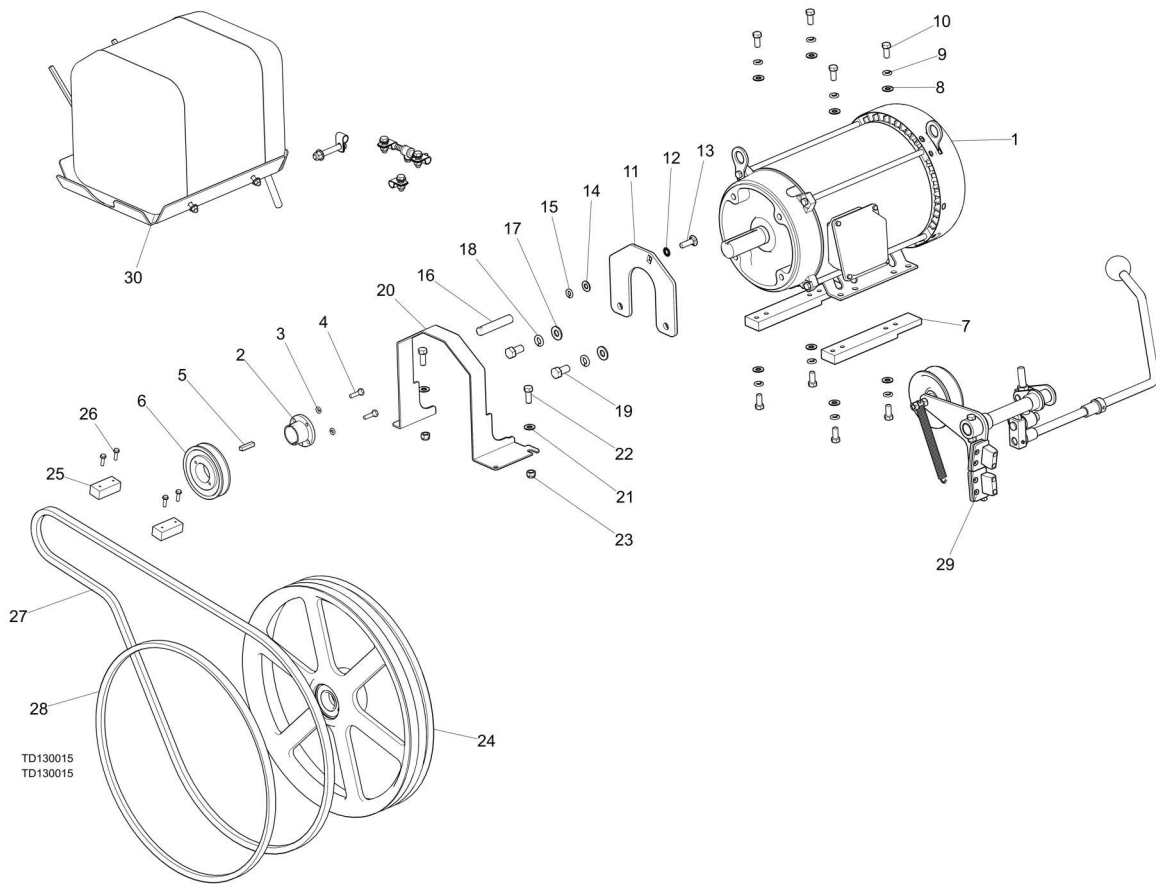

REF	PART #	DESCRIPTION	COMMENTS	QTY.
	130015	Module, HR130 E15 3PH Motor		1
	130014	Assembly, HR130 15HP 3PH Electric Motor		1
1	130000	Motor, 15HP 3530RPM Marathon Premium Eff		1
	p04864	Bushing, 1 3/8 Split Taper		1
2	qt138			1
3	f05011-14	Washer, 1/4 Split Lock		2
4	f05005-101	BOLT, 1/4-20 X 1 HEX HEAD GR5		2
5	qt138_key	Part, New		1
6	036057	Sheave, BK45QT		1
7	130011	Spacer, 3/4x1-1/2x9 Motor		2
8	f05011-3	Washer, 3/8 Flat SAE		8
9	f05011-4	Washer, 3/8 Split Lock		8
10	f05007-185	Bolt, 3/8-16x7/8 HH Gr5		8
	130048	Assembly, Clutch Enhancement	Clutch enhancement added after 7/1/2020 per ECN 37573	1
11	130047	Plate, Clutch Enhancement Mnt		1
12	f05011-36	Washer, 3/8 Star External		1
13	f05007-127	Bolt, 3/8-16x1 1/4 Carriage Gr5		1

REF	PART #	DESCRIPTION	COMMENTS	QTY.
14	f05011-3	Washer, 3/8 Flat SAE		1
15	f05011-4	Washer, 3/8 Split Lock		1
16	074751	Rod, LT70 Clutch Enhancement		1
17	f05011-2	Washer, 1/2 SAE Flat		2
18	f05011-9	Washer, 1/2 Split Lock		2
19	f05008-50	Bolt, 1/2-13x1 HH Gr2		2
20	034904	Guard, Motor Shaft LT15E10		1
21	f05011-3	Washer, 3/8 Flat SAE		2
22	f05007-7	Bolt, 3/8-16x1 HH		2
23	f05010-10	Nut, 3/8-16 Hex Nyl Lock		2
24	014995	Wheel Assembly, LT15 Drive	(See Section 2.1)	1
25	016506	Block, Wood 3/4x1x2-3/16		2
26	f05015-33	Screw,#10x3/4 SI Hex Washer Hd Sht Met		4
27	p25301	Belt, BX85		1
28	p04185	Belt, B57 Blade Wheel		1
29		Throttle/Clutch Assembly (E15)	(See Section 7.14)	1
30	015799	Tray Assembly, LT15 Water Bottle	See Section 4.2	1

7.5 Motor (E10)

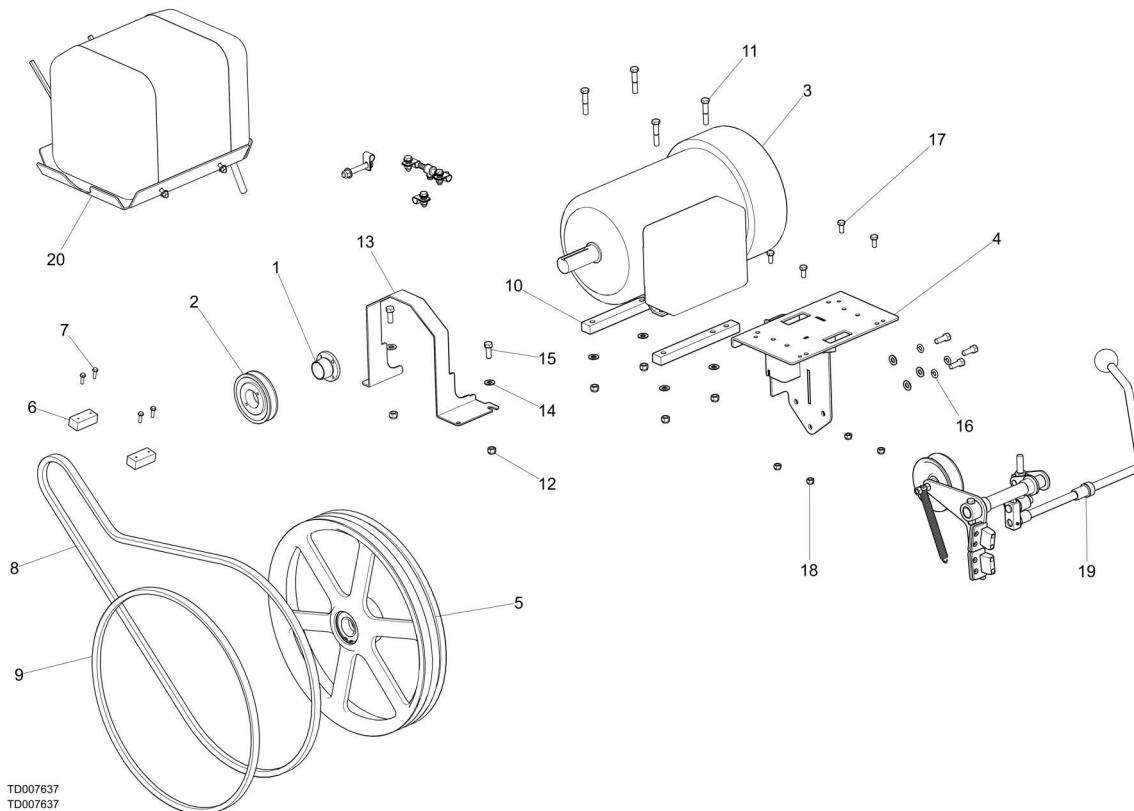

TD007637
TD007637

REF	PART #	DESCRIPTION	COMMENTS	QTY.
	007634	Motor Module, HR120 E10 1Ph		2
	036215.	Motor Assembly, LT15 10hp Single Phase		2
1	036214	Motor, 10hp Single Phase Lincoln 60Hz		2
2	p04864	Bushing, S/T H-1 3/8		2
3	036057	Sheave, BK45QT		2
4	034899	Mount Wldmt, Battery/Control Box		2
5	014995	Wheel Assembly, Lt15 Drive	(See Section 2.1)	2
6	016506	Block, Wood 3/4x1x2-3/16		4
7	f05015-33	Screw, #10x3/4 SI Hex Was Head Scr		8
8	p25301	Belt, BX85		2
9	p04185	BELT, B-57		2
10	034807	Spacer, Motor LT15E		4
11	f05007-124	Bolt, 3/8-16 x 2 HH Grd 8 YZD		8
12	f05010-10	Nut, 3/8-16 Hex Nyl Lock		12
13	034904	Guard, Motor Shaft LT15E10		2
14	f05011-3	Washer, 3/8 Flat SAE		18
15	f05007-7	Bolt, 3/8-16x1 HH		10
16	f05011-4	Washer, 3/8 Split Lock		6
17	f05006-102	Bolt, 5/16-18 x 3/4 HH Gr5		8
18	f05010-58.	Nut, 5/16-18 Nyl Lock		8
19		Throttle/Clutch Assembly (E15, E10)	(See Section 7.14)	1
20	015799	Tray Assembly, LT15 Water Bottle	See Section 4.2	1

7.6 Fuel Tank (G25)

HR120Rev. A4.04+

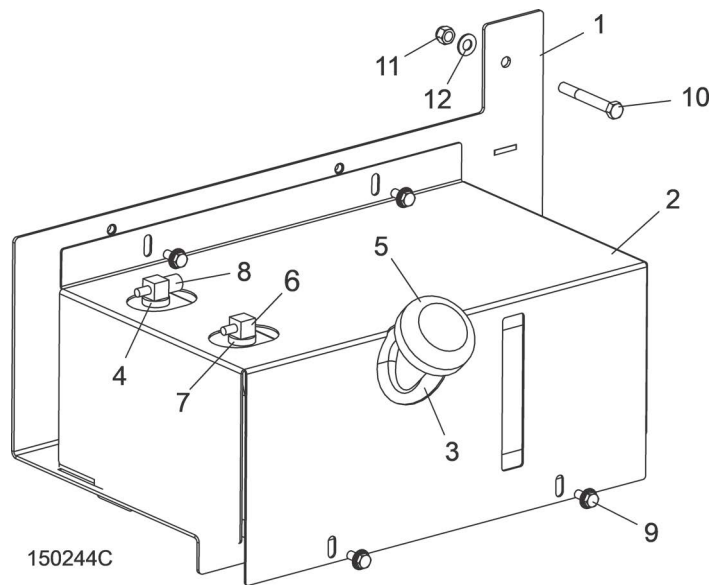

REF	PART #	DESCRIPTION	COMMENTS	QTY.
	103815	TRAY ASSEMBLY, LT15 FUEL TANK		1
1	103802	Weldment, Fuel Tank Tray		1
2	103867	Cover, Fuel Tank		1
3	103878	Tank, 5 Gallon Low Pro EPA Fuel	Fuel shut-off valve added to fuel tank to prevent possibility of fuel feeding back into engine during travel (HR120 Rev. A4.06). Created service part 074943 Fuel Pick-Up with Shut-Off Fitting.	1
4	F05006-101	Bolt, 5/16-18 x 3/4" Hex Head w/Flat&Lock Washer		4
5	F05007-73	Bolt, 3/8-16 x 3" Hex Head Grade 5		2
6	F05010-10	Nut, 3/8-16 Hex Nyloc		2
7	F05011-3	Washer, 3/8" Flat SAE		2
	R02423-1	Hose, Fuel 3/16" EPA 15G CARB		8 Ft.
	R02423-2	Hose, Fuel 1/4" EPA 15G CARB		8 Ft.

7.7 Fuel Tank (G25)

HR120Rev. A4.02 - A4.03

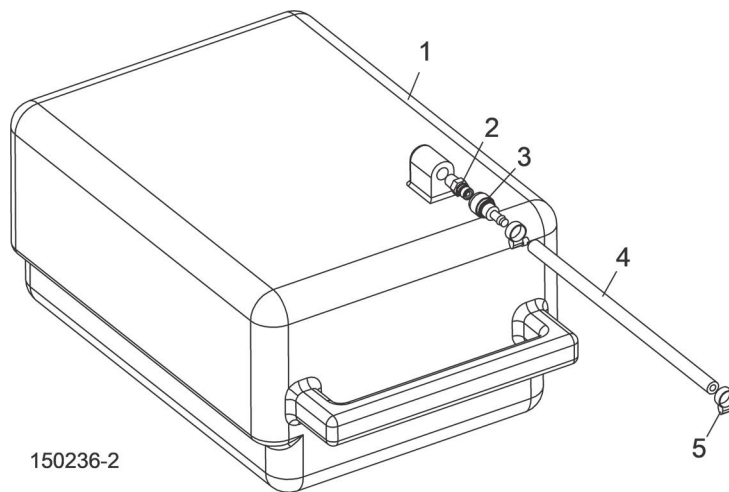

REF	PART #	DESCRIPTION	COMMENTS	QTY.
1	076478	TANK, GAS		1
2	015583	FITTING, 1/4" NPT MALE QUICK DISCONNECT		1
3	015582	FITTING, FEMALE QUICK DISCONNECT BARB		1
4	P642	HOSE, 1/4" ID FUEL		9.3 Ft
5	P649	CLAMP, 7/32" - 1/2" HOSE		2

7.8 Fuel Tank (G25)

HR120Rev. A1.00 - A4.01

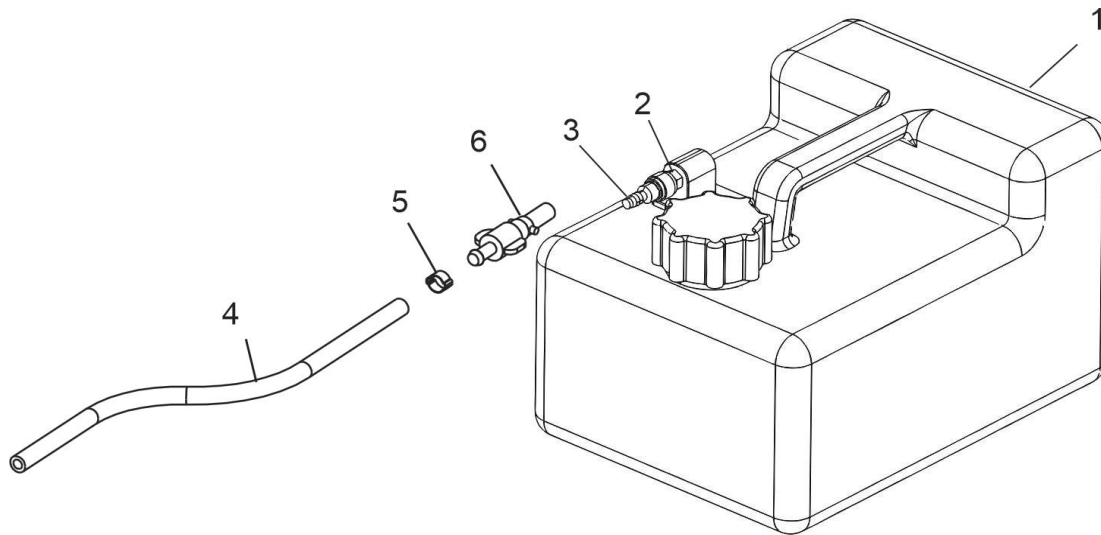

3H0415D

REF	PART #	DESCRIPTION	COMMENTS	QTY.
	074664	Assy, 3 Gallon Gas Tank, Single Line	Replaced A12285 for service after 9/28/23 per ECN 39168	1
1	X200-1144	Can, 3 Gallon Gas		1
2	015583	Fitting, 1/4 NPT Male Quick Disconnect		1
3	015582	Fitting, Female Quick Disconnect Barb		1
	A12285	Tank Assembly, 5-gallon Red Gasoline	Customers with sawmills and edgers manufactured in 2010 and later need to use new EPA approved 3 or 6 gallon gas can assemblies (see technical bulletin TB150005 for more information). Replace with 074664 after 9/28/23 per ECN 39168.	1
	P12167	Tank, 5-Gallon Red Fuel	Deleted after 9/28/2023 per ECN 39168	1
	P12172	Pickup, 9" Fuel		1
	P09683	Cap, 3 or 5-Gallon Fuel Tank		1
	P12175	Fitting, 1/4" NPT Plastic Female Disconnect		1
	P10367	Fitting, 3/8" NPT Hex Plug		1
4	P642	HOSE, 1/4" ID FUEL		8 Ft
5	P649	CLAMP, 7/32 - 1/2 HOSE		2
6	P12176	FITTING, 1/4" NPT PLASTIC MALE DISCONNECT	Replacement requires qty. 1 hose clamp (P649).	1

7.9 Fuel Tank (D17)

HR120Rev. A4.05+

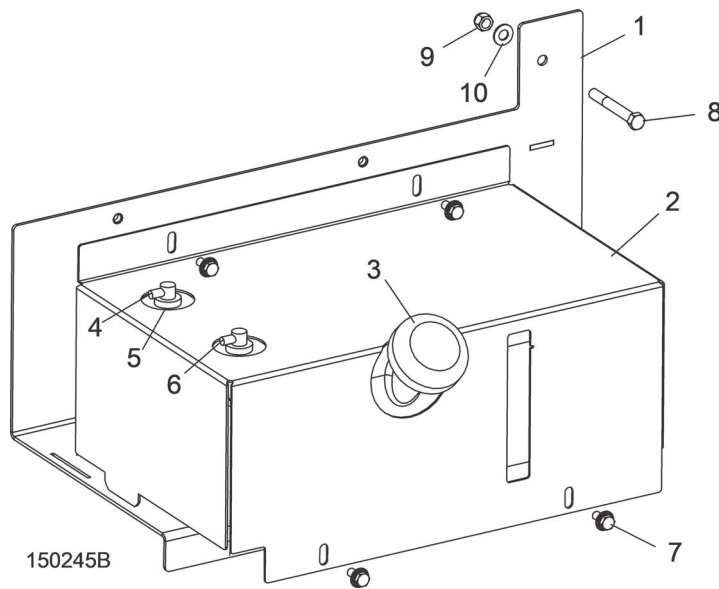

REF	PART #	DESCRIPTION	COMMENTS	QTY.
	074828	TANK ASSEMBLY, 5 GALLON DIESEL		1
1	103802	Weldment, Fuel Tank Tray		1
2	103867	Cover, Fuel Tank		1
3	103928	Tank, 5 Gallon Low Pro Diesel		1
4	F05006-101	Bolt, 5/16-18 x 3/4" Hex Head w/Flat&Lock Washer		4
5	F05007-73	Bolt, 3/8-16 x 3" Hex Head Grade 5		2
6	F05010-10	Nut, 3/8-16 Hex Nyloc		2
7	F05011-3	Washer, 3/8" Flat SAE		2
	R02423-3	Hose, Fuel 5/16" EPA 15G CARB		8 Ft.
	R02423-2	Hose, Fuel 1/4" EPA 15G CARB		8 Ft.
	103802	Weldment, Fuel Tank Tray		1
	P649	Clamp, 7/32in-5/8in Hose		2
	P07584	Clamp, 1/2EMT Coated		1

7.10 Fuel Tank (D17)

HR120Rev. A1.00 - A4.04

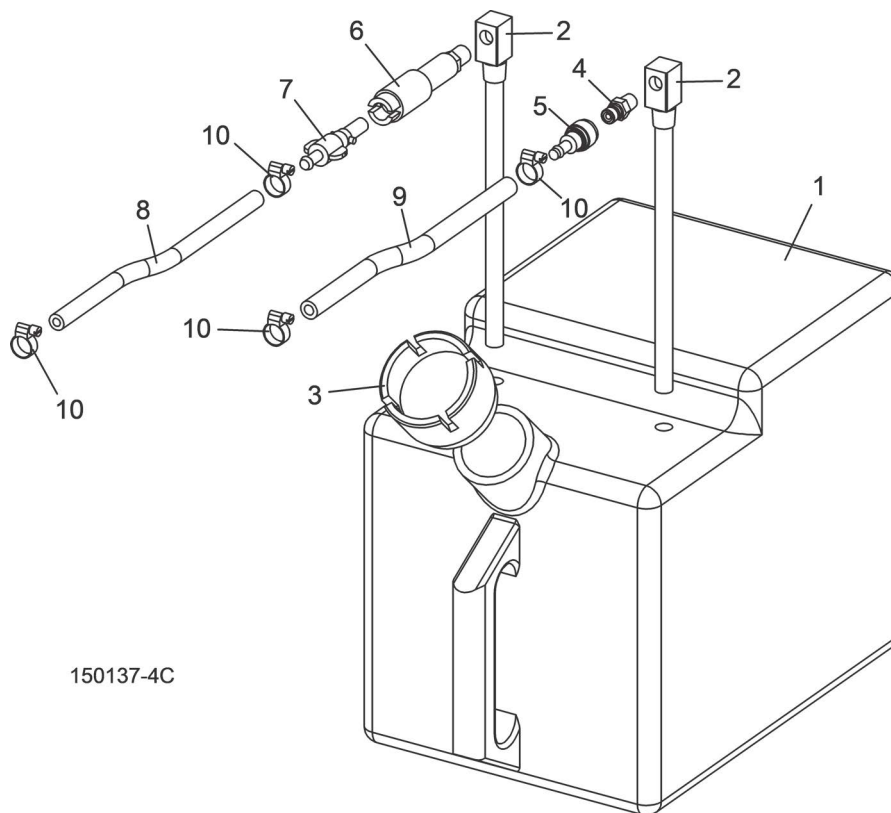

150137-4C

REF	PART #	DESCRIPTION	COMMENTS	QTY.
	A12132	TANK ASSEMBLY, 5 GALLON DIESEL		1
1	P12166	Tank, 5-Gallon Diesel Fuel	Available in assemblies only.	1
2	P12172	Fitting, 1/4" NPT x 9" Fuel Pickup		2
3	P09683	Cap, 3 or 5-Gallon Fuel Tank		1
4	015583	Fitting, 1/4" NPT Male Quick Disconnect		1
5	015582	Fitting, Female Quick Disconnect Barb		1
6	P12175	Fitting, 1/4" NPT Plastic Female Disconnect		1
7	P12176	Fitting, 1/4" NPT Plastic Male Disconnect		1
8	P642	HOSE, 1/4" ID FUEL		7.5 Ft
9	016338	HOSE, 5/16" FUEL LINE		7 Ft
10	P649	CLAMP, 7/32"-1/2" HOSE		4

7.11 Throttle/Clutch Assembly (G15)

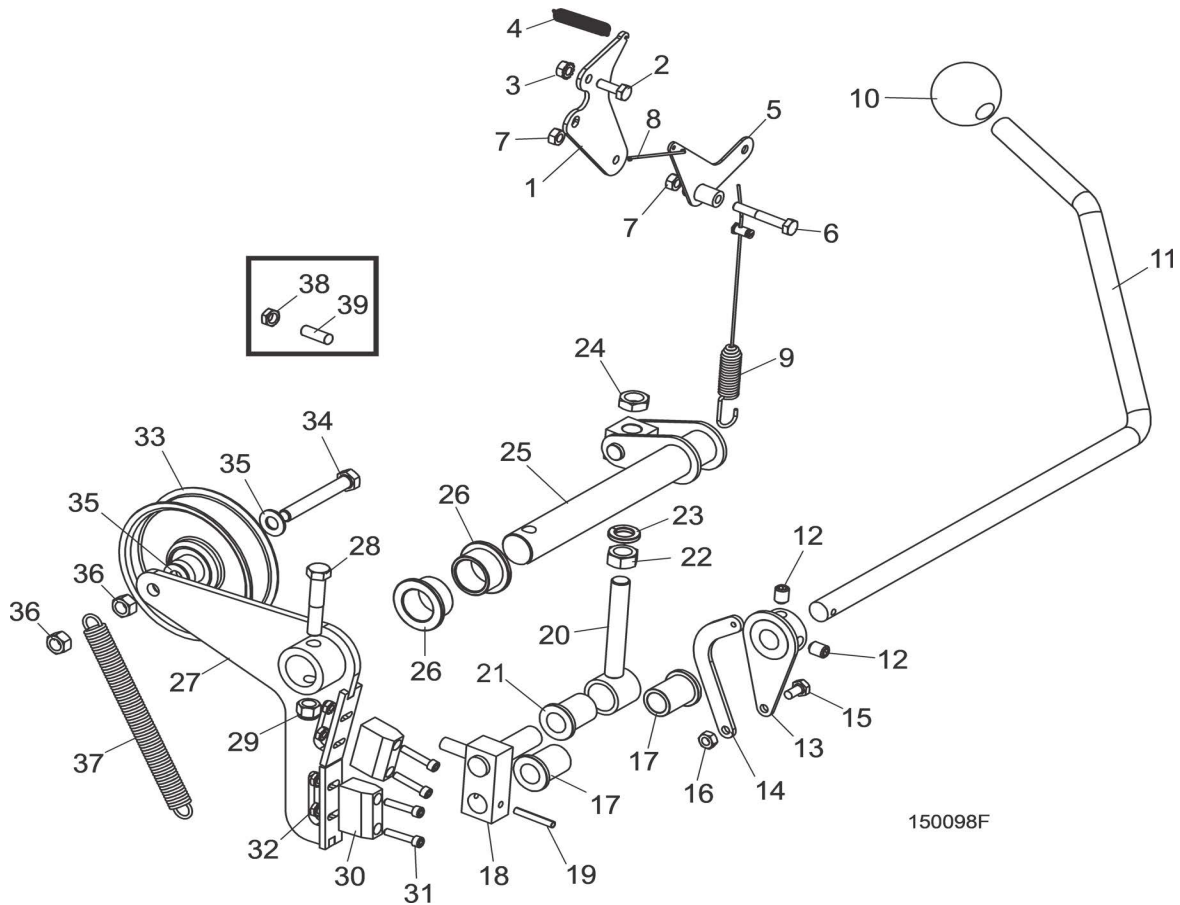

REF	PART #	DESCRIPTION	COMMENTS	QTY.
1	034616	PLATE, THROTTLE CABLE BRACKET LT15G		1
2	F05005-1	SCREW, 1/4-20 X 3/4 FT HEX HEAD		1
3	F05010-9	NUT, 1/4-20 SELF-LOCKING HEX		1
4	014818	SPRING, EXTENSION 3/8 X 3		1
5	034805	PIVOT WELDMENT, THROTTLE LT15G		1
6	F05005-4	BOLT, 1/4-20 X 1 3/4" HEX HEAD		1
7	F05010-21	NUT, 1/4-20 SWAGED		2
8	015446	LINK, THROTTLE 2 13/16		1
9	034838	CABLE ASSEMBLY, LT15G15 THROTTLE		1
10	P04211	KNOB, 5/8-11 BALL		1
11	016487	HANDLE, LT15 CLUTCH		1
12	F05007-12	SCREW, 3/8-16 X 1/2 SOCKET HEAD CUP PT SET		2
13	034815	ACTUATOR WELDMENT, THROTTLE LT15D&G		1
14	034818	LINKAGE, THROTTLE LT15D&G		1
15	F05005-15	BOLT, 1/4-20 X 1/2" HEX HEAD		1
16	F05010-21	NUT, 1/4-20 SWAGED		1
17	016486	BUSHING, 5/8" ID X 7/8" OD X 1 1/8" LONG FLANGED BRONZE		2
18	034612	BLOCK WELDMENT, LINKAGE CLUTCH/BRAKE		1
19	F05012-16	PIN, 3/16 X 1 1/4 ROLL		1

REF	PART #	DESCRIPTION	COMMENTS	QTY.
20	034605	LINKAGE ASSEMBLY, W/BEARING		1
21	016486	Bushing, 5/8" ID x 7/8" OD x 1 1/8" Long Flanged Bronze		1
22	F05010-35	NUT, 1/2-13 FREE HEX, ZINC		1
23	F05011-9	WASHER, 1/2 SPLIT LOCK		1
24	F05010-31	NUT, 1/2-13 JAM		1
25	034608	PIVOT WELDMENT, CLUTCH/BRAKE		1
26	P737	BUSHING, 1 X 1 1/4 X 3/4 FLG BRONZE		2
	034603	BRAKE/CLUTCH ASSEMBLY, LT15		1
27	034613	Arm Weldment, Clutch/Brake LT15		1
28	F05007-124	Bolt, 3/8-16 x 2 Hex Head Gr5		1
29	F05010-10	Nut, 3/8-16 Hex Nylon Lock		2
30	016488	Block, LT15 Brake		2
31	F05004-2	Screw, 10-24 x 1" Socket Head		4
32	F05010-14	Nut, #10-24 Keps		4
33	034602	Idler, 4" O.D. x 3/8 Bore		1
34	F05007-125	Bolt, 3/8-16 x 2-1/2 Hex Head Gr5		1
35	F05011-3	Washer, 3/8 Flat		3
36	F05010-25	Nut, 3/8-16 Swaged Lock		1
37	034810	Spring, Idler Arm LT15/D/E/G		1

7.12 Throttle/Clutch Assembly (G18/G25)

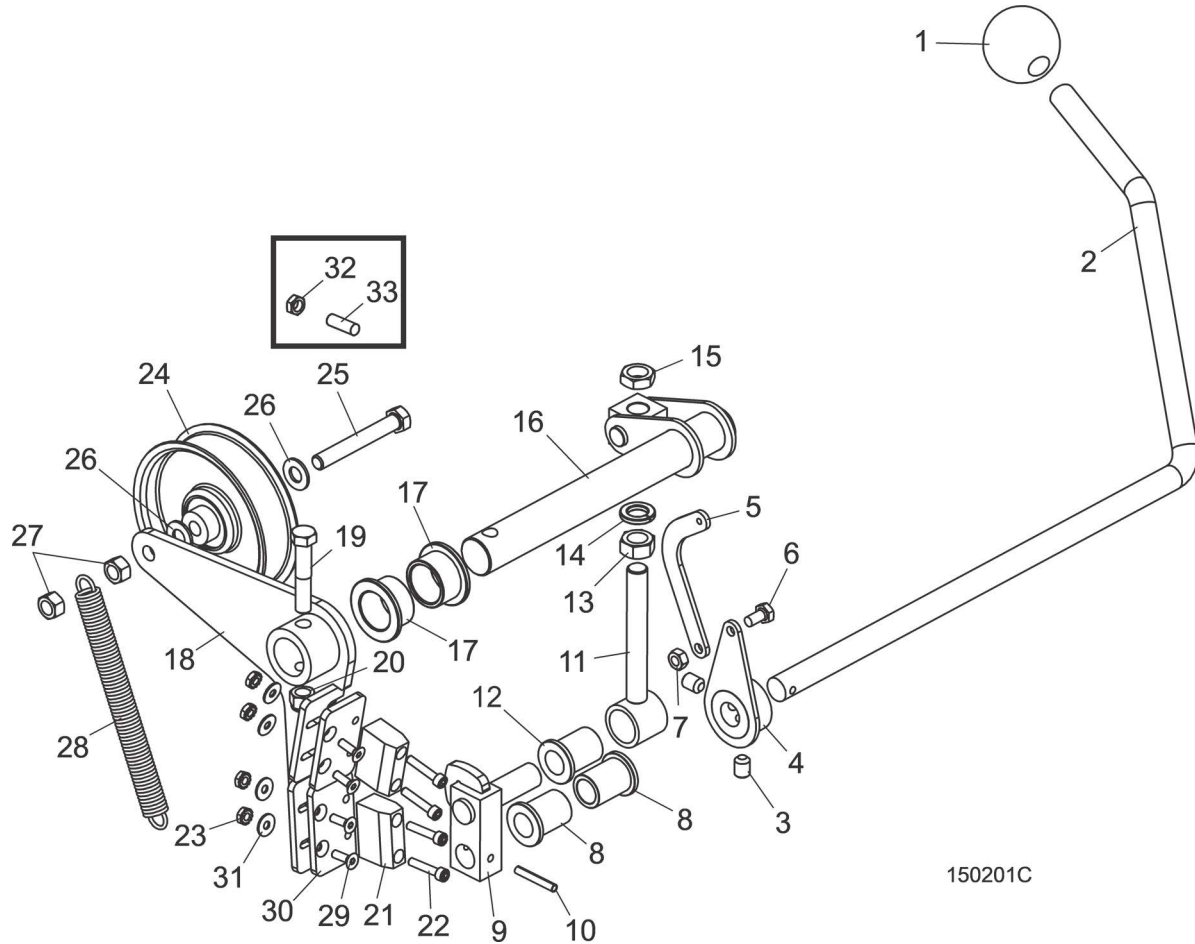

150201C

REF	PART #	DESCRIPTION	COMMENTS	QTY.
1	P04211	KNOB, 5/8-11 BALL		1
2	016487	HANDLE, LT15 CLUTCH		1
3	F05007-12	SCREW, 3/8-16 X 1/2 SOCKET HEAD CUP PT SET		2
4	034815	ACTUATOR WELDMENT, THROTTLE LT15D&G		1
5	034818	LINKAGE, THROTTLE LT15D&G		1
6	F05005-15	BOLT, 1/4-20 X 1/2" HEX HEAD		1
7	F05010-21	NUT, 1/4-20 SWAGED		1
8	016486	BUSHING, 5/8" ID X 7/8" OD X 1 1/8" LONG FLANGED BRONZE		2
9	065572	BLOCK WELDMENT, LINKAGE CLUTCH/BRAKE	Replaces 034612 to make clutch pivot stop adjustable Rev. A2.02.	1
10	F05012-16	PIN, 3/16 X 1 1/4 ROLL		1
11	034605	LINKAGE ASSEMBLY, W/BEARING		1
12	016486	Bushing, 5/8" ID x 7/8" OD x 1 1/8" Long Flanged Bronze		1
13	F05010-35	NUT, 1/2-13 FREE HEX, ZINC		1
14	F05011-9	WASHER, 1/2 SPLIT LOCK		1
15	F05010-31	NUT, 1/2-13 JAM		1
16	034608	PIVOT WELDMENT, CLUTCH/BRAKE		1

REF	PART #	DESCRIPTION	COMMENTS	QTY.
17	P737	BUSHING, 1 X 1 1/4 X 3/4 FLG BRONZE		2
	065874	BRAKE/CLUTCH ASSEMBLY, LT15	Replaces Brake/Clutch Assembly 034603 to improve durability (Rev. A3.00).	1
18	065873	Arm Weldment, Clutch/Brake LT15		1
19	F05007-124	Bolt, 3/8-16 x 2 Hex Head Gr5		1
20	F05010-10	Nut, 3/8-16 Hex Nylon Lock		2
21	016488	Block, LT15 Brake		2
22	F05004-2	Screw, 10-24 x 1" Socket Head		4
23	F05010-14	Nut, #10-24 Keps		4
24	034602	Idler, 4" O.D. x 3/8 Bore		1
25	F05007-125	Bolt, 3/8-16 x 2-1/2 Hex Head Gr5		1
26	F05011-3	Washer, 3/8 Flat		3
27	F05010-25	Nut, 3/8-16 Swaged Lock		1
28	034810	Spring, Idler Arm LT15/D/E/G		1
29	F05004-282	Screw, 10-24 x 5/8" FSHC		4
30	065872	Plate, Brake Adjustment		2
31	F05011-18	Washer, #10 SAE Flat		4

7.13 Throttle/Clutch Assembly (D17)

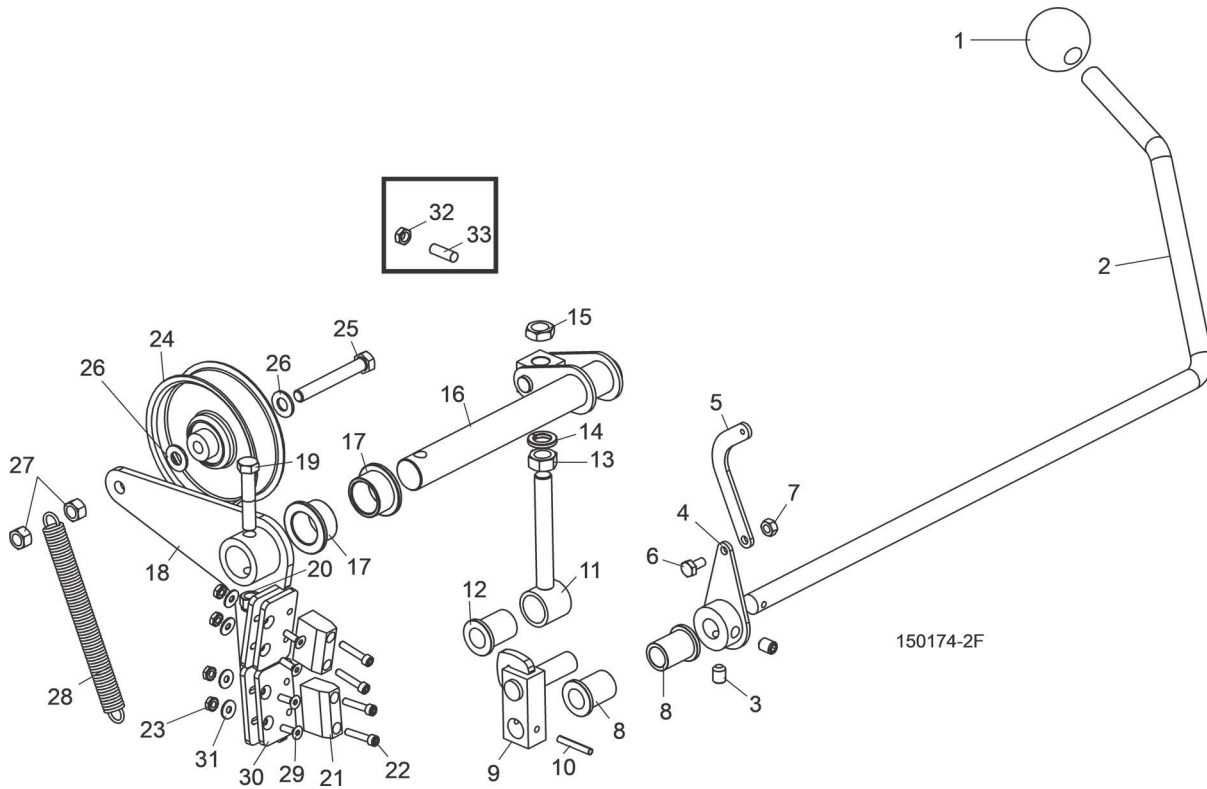

REF	PART #	DESCRIPTION	COMMENTS	QTY.
1	P04211	KNOB, 5/8-11 BALL		1
2	062313	HANDLE, LT15 CLUTCH		1
3	F05007-12	SCREW, 3/8-16 X 1/2" SOCKET HEAD CUP PT SET		2
4	034815	ACTUATOR WELDMENT, THROTTLE LT15D&G		1
5	034818	LINKAGE, THROTTLE LT15D&G		1
6	F05005-15	BOLT, 1/4-20 X 1/2" HEX HEAD		1
7	F05010-21	NUT, 1/4-20 SWAGED		1
8	016486	BUSHING, 5/8" ID X 7/8" OD X 1 1/8" LONG FL BRONZE		2
9	065572	BLOCK WELDMENT, LINKAGE CLUTCH/BRAKE	Replaces 034612 to make clutch pivot stop adjustable Rev. A2.02.	1
10	F05012-16	PIN, 3/16" X 1 1/4" ROLL		1
	034605	LINKAGE ASSEMBLY, W/BEARING		1
11	034604	Link Weldment, Clutch/Brake	Available in assemblies only.	1
12	016486	Bushing, 5/8" ID x 7/8" OD x 1 1/8" Long Fl Bronze		1
13	F05010-35	NUT, 1/2-13 FREE HEX, ZINC		1
14	F05011-9	WASHER, 1/2" SPLIT LOCK		1
15	F05010-31	NUT, 1/2-13 JAM		1
16	034608	PIVOT WELDMENT, CLUTCH/BRAKE		1
17	P737	BUSHING, 1" X 1 1/4" X 3/4" FLG BRONZE		2

REF	PART #	DESCRIPTION	COMMENTS	QTY.
	065874	BRAKE/CLUTCH ASSEMBLY, LT15	Replaces Brake/Clutch Assembly 034603 to improve durability (Rev. A3.00). Brake/Clutch Assembly 034603 (including Clutch/Brake Arm Weldment 034613) modified 9/10. Spring mount hardware changed to provide more freedom of movement and prevent binding point in spring.	1
18	065873	Arm Weldment, Clutch/Brake LT15		1
19	F05007-124	Bolt, 3/8-16 x 2" Hex Head Gr5		1
20	F05010-10	Nut, 3/8-16 Hex Nylon Lock		2
21	016488	Block, LT15 Brake		2
22	F05004-2	Screw, 10-24 x 1" Socket Head		4
23	F05010-14	Nut, #10-24 Keps		4
24	034602	Idler, 4" O.D. x 3/8" Bore		1
25	F05007-230	Bolt, 3/8-16 x 2-3/4" Hex Head Gr5 Full Thread	Replaces Brake/Clutch Assembly 034603 to improve durability (Rev. A3.00). Brake/Clutch Assembly 034603 (including Clutch/Brake Arm Weldment 034613) modified 9/10. Spring mount hardware changed to provide more freedom of movement and prevent binding point in spring.	1
26	F05011-3	Washer, 3/8" Flat		3
27	F05010-25	Nut, 3/8-16 Swaged Lock		1
28	034810	Spring, Idler Arm LT15D/E/G		1
29	F05004-282	Screw, 10-24 x 5/8" FSHC		4
30	065872	Plate, Brake Adjustment		2
31	F05011-18	Washer, #10 SAE Flat		4

7.14 Throttle/Clutch Assembly (E10/E15)

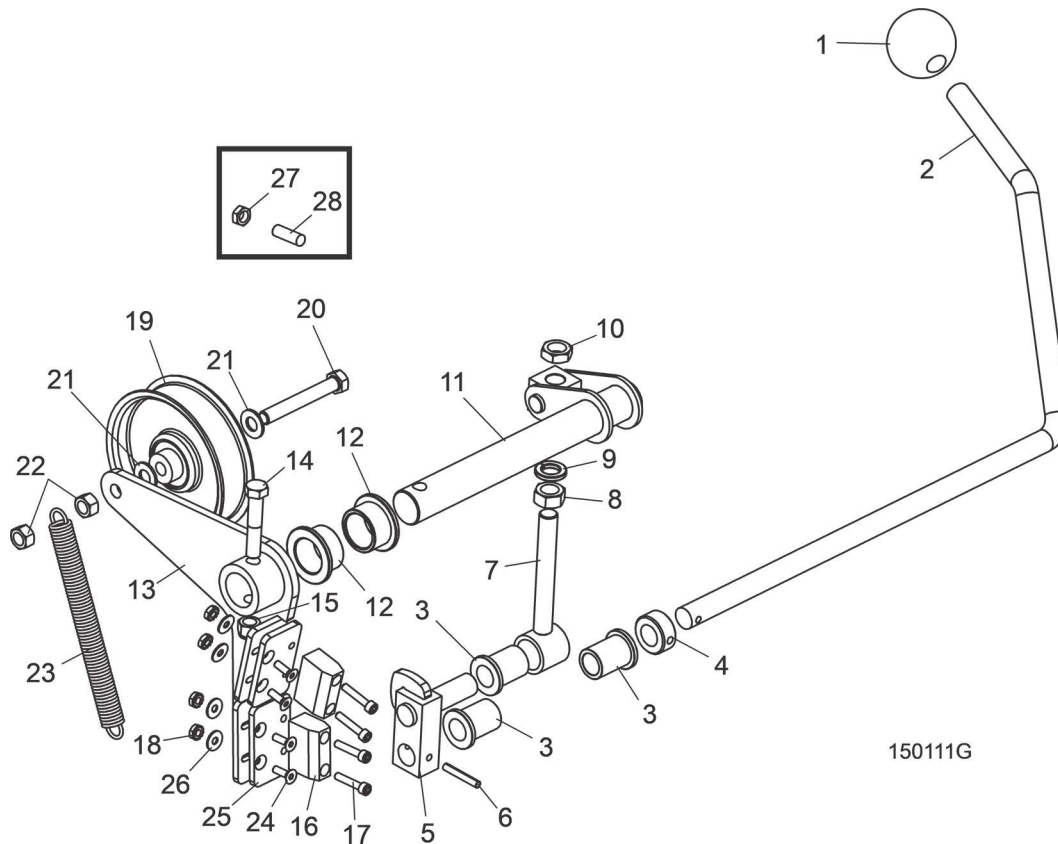

REF	PART #	DESCRIPTION	COMMENTS	QTY.
1	P04211	KNOB, 5/8-11 BALL		1
2	016487	HANDLE, LT15 CLUTCH		1
3	016486	BUSHING, 5/8 ID X 7/8 OD X 1 1/8 LONG FL BRONZE		2
4	P05035	COLLAR, 5/8 ID LOCK		1
5	065572	BLOCK WELDMENT, LINKAGE CLUTCH/BRAKE	Replaces 034612 to make clutch pivot stop adjustable Rev. A2.02.	1
6	F05012-16	PIN, 3/16 X 1 1/4 ROLL		1
7	034605	LINKAGE ASSEMBLY, W/BEARING		1
8	F05010-35	NUT, 1/2-13 FREE HEX, ZINC		1
9	F05011-9	WASHER, 1/2 SPLIT LOCK		1
10	F05010-31	NUT, 1/2-13 JAM		1
11	034608	PIVOT WELDMENT, CLUTCH/BRAKE		1
12	P737	BUSHING, 1 X 1 1/4 X 3/4 FLANGE BRONZE		2
	065874	BRAKE/CLUTCH ASSEMBLY, LT15	Replaces Brake/Clutch Assembly 034603 to improve durability (Rev. A3.00).	1
13	065873	Arm Weldment, Clutch/Brake LT15		1
14	F05007-124	Bolt, 3/8-16 x 2 Hex Head Gr5		1
15	F05010-10	Nut, 3/8-16 Hex Nylon Lock		2
16	016488	Block, LT15 Brake		2
17	F05004-2	Screw, 10-24 x 1 Socket Head		4

REF	PART #	DESCRIPTION	COMMENTS	QTY.
18	F05010-14	Nut, #10-24 Keps		4
19	034602	Idler, 4" O.D. x 3/8 Bore		1
20	F05007-125	Bolt, 3/8-16 x 2-1/2 Hex Head Gr5		1
21	F05011-3	Washer, 3/8 Flat		3
22	F05010-25	Nut, 3/8-16 Swaged Lock		1
23	034810	Spring, Idler Arm LT15/D/E/G		1
24	F05004-282	Screw, 10-24 x 5/8" FSHC		4
25	065872	Plate, Brake Adjustment		2
26	F05011-18	Washer, #10 SAE Flat		4

SECTION 8 TABLE OPTION

8.1 HR100 Series Tables

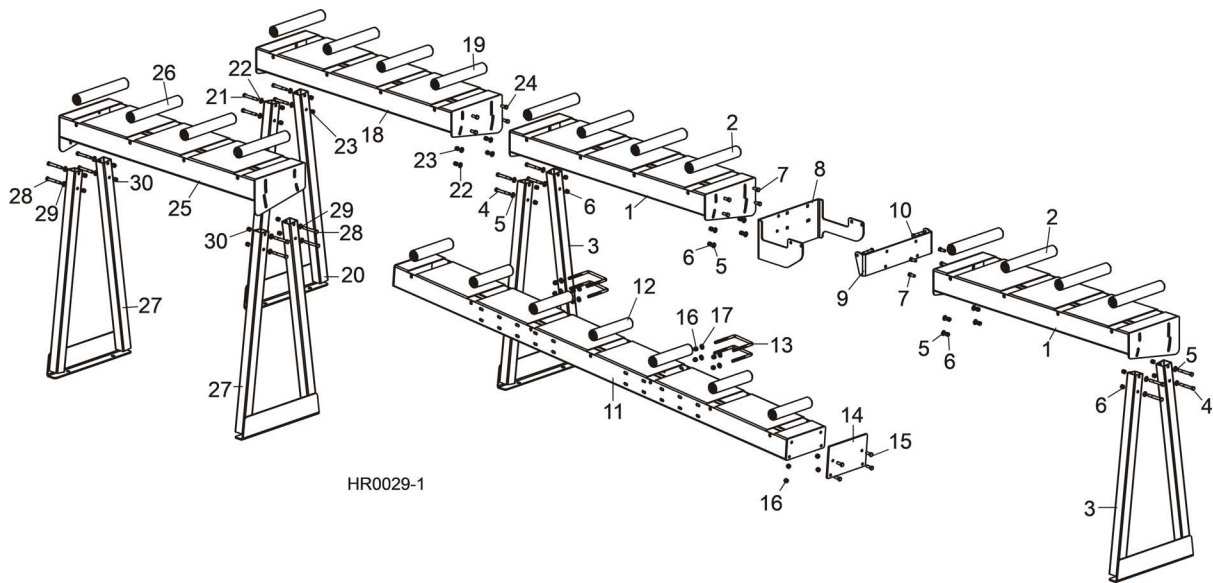

REF	PART #	DESCRIPTION	COMMENTS	QTY.
1-17	HRTBL-KIT	TABLE KIT, HR COMPLETE		1
1-7	HRTBL-END1	Table Kit, HR End		2
1	059561	Table Weldment, HR End		1
2	059563	Roller, 1.90" OD x 12"		4
3	059564	Leg Weldment, HR Table		1
4	F05007-73	Bolt, 3/8-16 x 3" Hex Head Grade 5		4
5	F05011-3	Washer, 3/8" SAE Flat		8
6	F05010-10	Nut, 3/8-16 Hex Nylon Lock		8
7	F05007-87	Bolt, 3/8-16 x 1" Hex Head Grade 5		4
8-10	HRTBL-MOUNT	Mount Kit, HR Table		1
8	059570	Plate, Table Mount Rear		1
9	059568	Plate, Table Mount		1
10	F05007-124	Bolt, 3/8-16 x 2" Hex Head Grade 5		2
11-17	HRTBL-SIDE	Table Kit, HR Side		1
11	059571	Table Weldment, HR Side		1
12	059584	Roller, 1.90" OD x 9"		7
13	003207	Bolt, 3/8-16 x 4" x 5" U		4
14	059574	Plate, Table Stop		1
15	F05007-87	Bolt, 3/8-16 x 1" Hex Head Grade 5		4
16	F05010-10	Nut, 3/8-16 Hex Nylon Lock		12
17	F05011-3	Washer, 3/8" Flat SAE		8
18-24	HRTBL-END1	TABLE KIT, HR 4' EXTENSION END		1
18	059561	Table Weldment, HR End		1
19	059563	Roller, 1.90" OD x 12"		4
20	059564	Leg Weldment, HR Table		1
21	F05007-73	Bolt, 3/8-16 x 3" Hex Head Grade 5		4

REF	PART #	DESCRIPTION	COMMENTS	QTY.
22	F05011-3	Washer, 3/8" SAE Flat		8
23	F05010-10	Nut, 3/8-16 Hex Nylon Lock		8
24	F05007-87	Bolt, 3/8-16 x 1" Hex Head Grade 5		4
25-30	HRTBL-END2	TABLE KIT, HR STAND-ALONE END		1
25	059561	Table Weldment, HR End		1
26	059563	Roller, 1.90" OD x 12"		4
27	059564	Leg Weldment, HR Table		2
28	F05007-73	Bolt, 3/8-16 x 3" Hex Head Grade 5		8
29	F05011-3	Washer, 3/8" SAE Flat		8
30	F05010-10	Nut, 3/8-16 Hex Nylon Lock		8