

Wood-Mizer® HR120 Resaw

Parts Manual

HR120

Rev. A6.00 - A6.00

Safety is our #1 concern!

Form #1627



WARNING! Read and understand this manual before using this machine.

California

Proposition 65 Warning



WARNING: Breathing gas/diesel engine exhaust exposes you to chemicals known to the State of California to cause cancer and birth defects or other reproductive harm.

Always start and operate the engine in a well-ventilated area.
If in an enclosed area, vent the exhaust to the outside.
Do not modify or tamper with the exhaust system.
Do not idle the engine except as necessary.

For more information go to www.P65warnings.ca.gov.



WARNING: Drilling, sawing, sanding or machining wood products can expose you to wood dust, a substance known to the State of California to cause cancer. Avoid inhaling wood dust or use a dust mask or other safeguards for personal protection.

For more information go to www.P65Warnings.ca.gov/wood.

Active Patents assigned to Wood-Mizer, LLC

Wood-Mizer, LLC has received patents that protect our inventions which are a result of a dedication to research, innovation, development, and design. Learn more at: woodmizer.com/patents

©2024 Wood-Mizer LLC

Printed in the United States of America, all rights reserved. No part of this manual may be reproduced in any form by any photographic, electronic, mechanical or other means or used in any information storage and retrieval system without written permission from

Wood-Mizer, LLC
8180 West 10th Street
Indianapolis, Indiana 46214

SECTION 1 REPLACEMENT PARTS

1.1 How To Use The Parts List..... 1-1
 1.2 Sample Assembly..... 1-1
 1.3 Torque Values 1-2
 1.4 1-3

SECTION 2 BLADE GUIDE ROLLERS & ARM

2.1 Blade Guide Assembly, Idle Side 2-1
 2.2 Blade Guide Assembly, Drive Side 2-3
 2.3 Blade Guide Arm 2-5

SECTION 3 BLADE WHEELS AND TENSIONER

3.1 Blade Drive Assembly 3-1
 3.2 Idle Blade Wheel Assembly..... 3-3
 3.3 Blade Tensioner Assembly 3-5

SECTION 4 SAW HEAD ASSEMBLIES

4.1 Blade Housing Covers & Wood Blocks 4-1
 4.2 Water Lube Assembly..... 4-4
 4.3 Saw Head Decals 4-6

SECTION 5 CONTROL & BATTERY BOXES

5.1 Battery Box Assembly 5-1
 5.2 Feed Control Box Assembly (HR120G18/G25)..... 5-2
 5.3 Feed Control Box Assembly (HR120D17)..... 5-3
 5.4 Feed Control Box Assembly (HR120E10) 5-4
 5.5 Up/Down Control Box Assembly (G18/G25) 5-5
 5.6 Up/Down Control Box Assembly (D17) 5-7
 5.7 Up/Down Control Box Assembly (HR120E10/HR120EA10) 5-9
 5.8 Control Panel Components (HR120EA10)..... 5-11
 5.9 Control Insert Components (HR120EA10)..... 5-12

SECTION 6 UP-DOWN SYSTEM

6.1 Saw Head Lift 6-1
 6.2 Saw Head Mount & Blade Height Scale..... 6-3

SECTION 7 CONVEYOR BELT FEED SYSTEM

7.1 Feed Belt Conveyor 7-1
 7.2 Hold-Down Assembly..... 7-3
 7.3 Conveyor Feed Assembly 7-4
 7.4 Shingle Belt Assembly (Optional) 7-5

SECTION 8 ENGINE ASSEMBLY

8.1 Engine (G19)..... 8-1
 8.2 Engine (G25)..... 8-3
 8.3 Engine (D17)..... 8-5
 8.4 Motor (E10) 8-7

Table of Contents

Section-Page

8.5	Fuel Tank (G25)	8-9
8.6	Fuel Tank (D17)	8-10
8.7	Throttle/Clutch Assembly (G18/G25).....	8-11
8.8	Throttle/Clutch Assembly (D17).....	8-13
8.9	Throttle/Clutch Assembly (E10)	8-15

SECTION 9 TABLE OPTION

9.1	HR100 Series Tables	9-1
-----	---------------------------	-----

SECTION 1 REPLACEMENT PARTS

1.1 How To Use The Parts List

- Use the table of contents to locate the assembly that contains the part you need.
- Go to the appropriate section and locate the part in the illustration.
- Use the number pointing to the part to locate the correct part number and description in the table.
- Parts shown indented under another part are included with that part.

To Order Parts

- From the continental US, call **1-800-525-8100** to order parts. Have your customer number, vehicle identification number, and part numbers ready when you call.
- From other international locations, contact the Wood-Mizer distributor in your area for parts.

1.2 Sample Assembly



REF	PART #	DESCRIPTION	COMMENTS	QTY.
	012345	SAMPLE ASSEMBLY, COMPLETE	INCLUDES ITEMS 1-6	1
1	F02222-22	Sample Part		1
2	F03333-33	Sample Part		2
	098765	Sample Subassembly	Includes items 3-6	1
3	S04444-44	Subassembly Sample Part		1
4	K55555	Subassembly Sample Part		1
	054321	Sample Sub-Subassembly	Includes items 5-6	2
5	022222	Sub-Subassembly Sample Part		1
6	F10234-56	Sub-Subassembly Sample Part		1

The Sample Assembly, Complete, part number 02345 (top level assembly) includes two parts (F0222-22 and F0333-33) and the 098765 subassembly.

Subassembly 098765 contains two parts(S04444-44 and K55555) and two copies of sub-subassembly 054321.

Each sub-subassembly 054321 contains two parts (022222 and F10234-56).

1.3 Torque Values

Grade		Units	SAE 5	SAE 8
Grade Mark				
Bolt Dia.	Threads Per In.	Units	SAE 5	SAE 8
6	32	in-lbs (Nm)	20 (2.3)	-
8	32	in-lbs (Nm)	24 (2.7)	30 (3.4)
10	24	in-lbs (Nm)	35 (4.0)	45 (5.1)
10	32	in-lbs (Nm)	40 (4.5)	50 (5.7)
12	24	in-lbs (Nm)	50 (5.7)	65 (7.3)
1/4	20	in-lbs (Nm)	95 (10.7)	125 (14.1)
1/4	28	in-lbs (Nm)	95 (10.7)	150 (17.0)
5/16	18	ft-lbs (Nm)	17 (22.6)	23 (31.2)
5/16	24	ft-lbs (Nm)	20 (27.1)	25 (33.8)
3/8	16	ft-lbs (Nm)	30 (40.7)	40 (54.2)
3/8	24	ft-lbs (Nm)	35 (47.5)	45 (61.0)
7/16	14	ft-lbs (Nm)	50 (67.8)	65 (88.1)
7/16	20	ft-lbs (Nm)	55 (74.6)	70 (94.9)
1/2	13	ft-lbs (Nm)	75 (101.7)	100 (135.6)
1/2	20	ft-lbs (Nm)	85 (115.3)	110 (149.2)
9/16	12	ft-lbs (Nm)	105 (142.4)	135 (183.1)
9/16	18	ft-lbs (Nm)	115 (155.9)	150 (203.4)
5/8	11	ft-lbs (Nm)	150 (203.4)	195 (264.4)
5/8	18	ft-lbs (Nm)	160 (217.0)	210 (284.8)
3/4	10	ft-lbs (Nm)	170 (230.5)	220 (298.3)
3/4	16	ft-lbs (Nm)	175 (237.3)	225 (305.1)
7/8	9	ft-lbs (Nm)	302 (409.5)	473 (640.9)
7/8	14	ft-lbs (Nm)	300 (406.8)	400 (542.4)
1	8	ft-lbs (Nm)	466 (631.8)	714 (967.4)

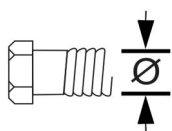

Metric Bolt Head Identification

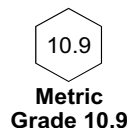
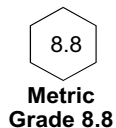

COARSE THREAD					FINE THREAD				Wrench Size	
Diameter & Thread Pitch	Metric 8.8		Metric 10.9		Diameter & Thread Pitch	Metric 8.8		Metric 10.9		
	N-m	lbs-ft	N-m	lbs-ft		N-m	lbs-ft	N-m		lbs-ft
6 x 1.0	8	6	11	8					10 mm	
8 x 1.25	20	15	27	20	8 x 1.0	21	16	29	22	13 mm
10 x 1.5	39	29	54	40	10 x 1.25	41	30	57	42	16 mm
12 x 1.75	68	50	94	70	12 x 1.25	75	55	103	76	18 mm
14 x 2.0	109	80	151	111	14 x 1.5	118	87	163	120	21 mm
16 x 2.0	169	125	234	173	16 x 1.5	181	133	250	184	24 mm
18 x 2.5	234	172	323	239	18 x 1.5	263	194	363	268	27 mm
20 x 2.5	330	244	457	337	20 x 1.5	367	270	507	374	30 mm
22 x 2.5	451	332	623	460	22 x 1.5	495	365	684	505	34 mm
24 x 3.0	571	421	790	583	24 x 2.0	623	459	861	635	36 mm
30 x 3.0	1175	867	1626	1199	30 x 2.0	1258	928	1740	1283	46 mm

1.4

SECTION 2 BLADE GUIDE ROLLERS & ARM

2.1 Blade Guide Assembly, Idle Side

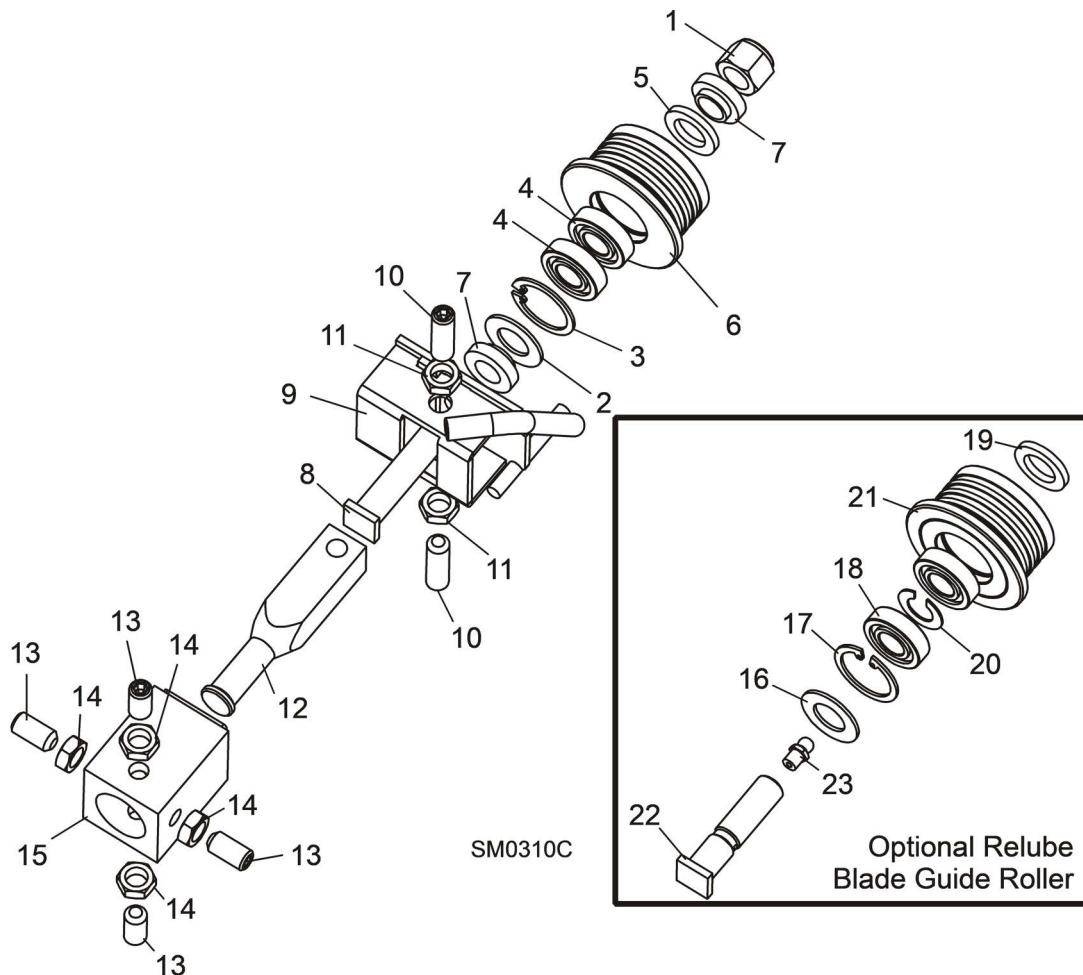

REF	PART #	DESCRIPTION	COMMENTS	QTY.
	A08197	BLADE GUIDE ASSEMBLY, COMPLETE IDLE SIDE		1
1	F05010-15	Nut, 1/2-20 Hex Nylon Lock		1
	A04925	Roller Assembly, Blade Guide	standard	1
	K07079	Bearing Kit, Blade Guide Rebuild		1
2	P04252	Washer, 5/8" White Felt		1
3	F04254-1	Ring, 1 1/8" Interior Retaining		1
4	015975	Bearing, R8-2RS Blade Guide	Available in assemblies only.	2
5	P06455	Washer, 5/8" Gray Felt		1
	F05005-105	Screw, 1/4-28 x 1/4" Socket Head Cup Point Set Black Oxide		1
	057407-1507	Instruction Sheet, Blade Guide Rebuild		1
6	S04250	Roller, Flanged Blade Guide	Available in assemblies only.	1
	A04925-364	Instruction Sheet, Blade Guide Roller Replacement		1

REF	PART #	DESCRIPTION	COMMENTS	QTY.
7	S04253	Spacer, Blade Guide		2
8	036373	Bolt, Blade Guide Roller		1
9	W08495	Bracket, Blade Guide Idle Side With Water Tube		1
10	F05007-96	Screw, 3/8-24 X 1 1/4" Stainless Steel Socket Head Flat Point		2
11	F05010-22	Nut, 3/8-24 Jam		2
12	S08196	Shaft, Blade Guide Adjustment		1
13	F05007-95	SCREW, 3/8-24 X 3/4" STAINLESS STEEL SOCKET HEAD FLAT POINT		4
14	F05010-22	NUT, 3/8-24 JAM		4
15	W08159	TUBE, BLADE GUIDE MOUNT	<i>(See Section 2.3)</i>	1
	016568	ROLLER ASSEMBLY, BLADE GUIDE RELUBE	Optional	1
	057407	Bearing Kit, Relube Blade Guide Rebuild		1
16	P04252	Washer, 5/8" White Felt		1
17	F04254-1	Ring, 1 1/8" Interior Retaining		1
18	015975	Bearing, R8-2RS Blade Guide	Available in assemblies only. Bearing must be modified for use with relube roller assemblies. Remove one seal from each bearing, place open sides facing each other and place spacer 035411 between bearings.	2
19	P06455	Washer, 5/8" Gray Felt		1
	057407-1507	Instruction Sheet, Blade Guide Rebuild		1
20	035411	Spacer, Blade Guide Bearing		1
21	035426	Roller, Flanged Blade Guide Relube	Available in assemblies only.	1
	A04925-364	Instruction Sheet, Blade Guide Roller Replacement		1
22	S08192	BOLT, BLADE GUIDE ROLLER	Relube only	1
23	P05060	FITTING, 1/4-28 GREASE	Relube only	1

2.2 Blade Guide Assembly, Drive Side

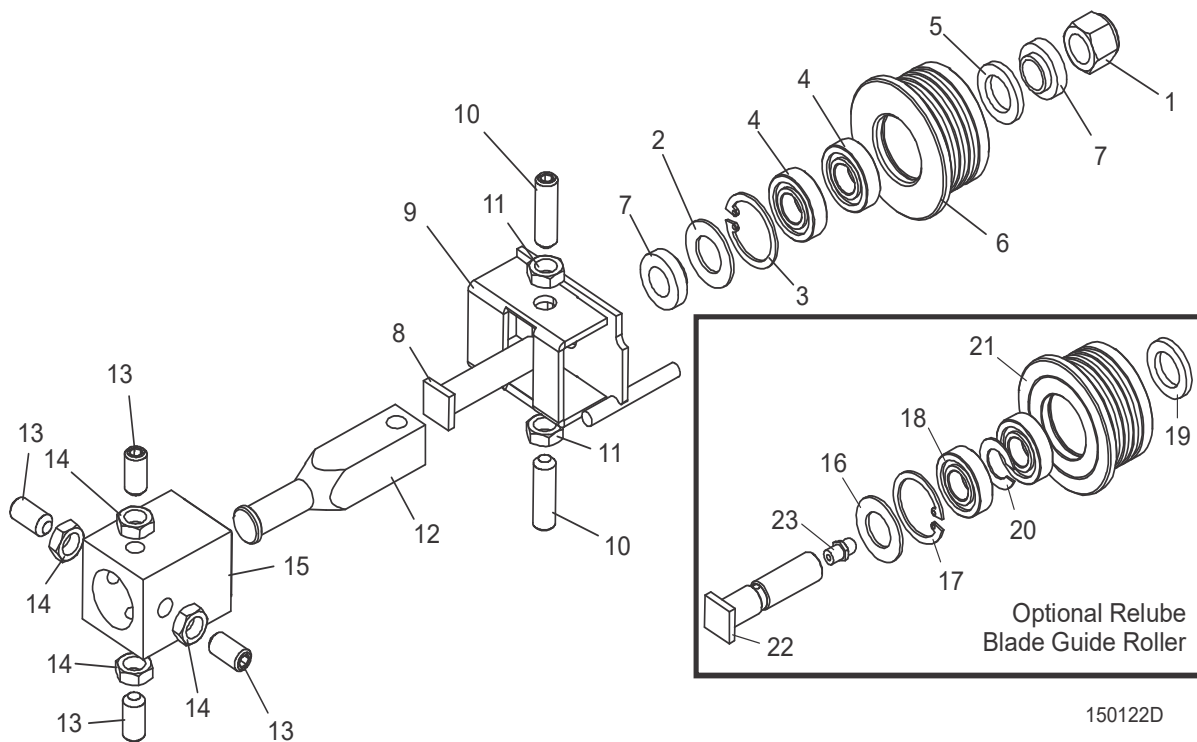

REF	PART #	DESCRIPTION	COMMENTS	QTY.
	A08191	BLADE GUIDE ASSEMBLY, COMPLETE DRIVE SIDE		1
1	F05010-15	Nut, 1/2-20 Hex Nylon Lock		1
	A04925	Roller Assembly, Blade Guide	Standard	1
	K07079	Bearing Kit, Blade Guide Rebuild		1
2	P04252	Washer, 5/8" White Felt		1
3	F04254-1	Ring, 1 1/8" Interior Retaining		1
4	015975	Bearing, R8-2RS Blade Guide	Available in assemblies only.	2
5	P06455	Washer, 5/8" Gray Felt		1
	F05005-105	Screw, 1/4-28 x 1/4" Socket Head Cup Point Set Black Oxide		1
	057407-1507	Instruction Sheet, Blade Guide Rebuild		1
6	S04250	Roller, Flanged Blade Guide	Available in assemblies only.	1
	A04925-364	Instruction Sheet, Blade Guide Roller Replacement		1
7	S04253	Spacer, Blade Guide		2
8	036373	Bolt, Blade Guide Roller		1
9	W08482	Bracket, Blade Guide Drive Side		1
10	F05007-96	Screw, 3/8-24 X 1 1/4" Stainless Steel Socket Head Flat Point		2
11	F05010-22	Nut, 3/8-24 Jam		2
12	S08196	Shaft, Blade Guide Adjustment		1
13	F05007-95	SCREW, 3/8-24 X 3/4" STAINLESS STEEL SOCKET HEAD FLAT POINT SET		3

REF	PART #	DESCRIPTION	COMMENTS	QTY.
14	F05007-99	BOLT, 3/8-24 X 1" STAINLESS STEEL HEX HEAD		1
15	F05010-22	NUT, 3/8-24 JAM		4
16	W08159	TUBE WELDMENT, BLADE GUIDE MOUNT	Part of saw frame weldment	1
	016568	ROLLER ASSEMBLY, BLADE GUIDE RELUBE	Optional	1
	057407	Bearing Kit, Relube Blade Guide Rebuild		1
17	P04252	Washer, 5/8" White Felt		1
18	F04254-1	Ring, 1 1/8" Interior Retaining		1
19	015975	Bearing, R8-2RS Blade Guide	Available in assemblies only. Bearing must be modified for use with relube roller assemblies. Remove one seal from each bearing, place open sides facing each other and place spacer 035411 between bearings.	2
20	P06455	Washer, 5/8" Gray Felt		1
21	035411	Spacer, Blade Guide Bearing		1
	057407-1507	Instruction Sheet, Blade Guide Rebuild		1
22	035426	Roller, Flanged Blade Guide Relube	Available in assemblies only.	1
	A04925-364	Instruction Sheet, Blade Guide Roller Replacement		1
23	S08192	BOLT, BLADE GUIDE ROLLER	Relube only	1
24	P05060	FITTING, 1/4-28 GREASE	Relube only	1

2.3 Blade Guide Arm

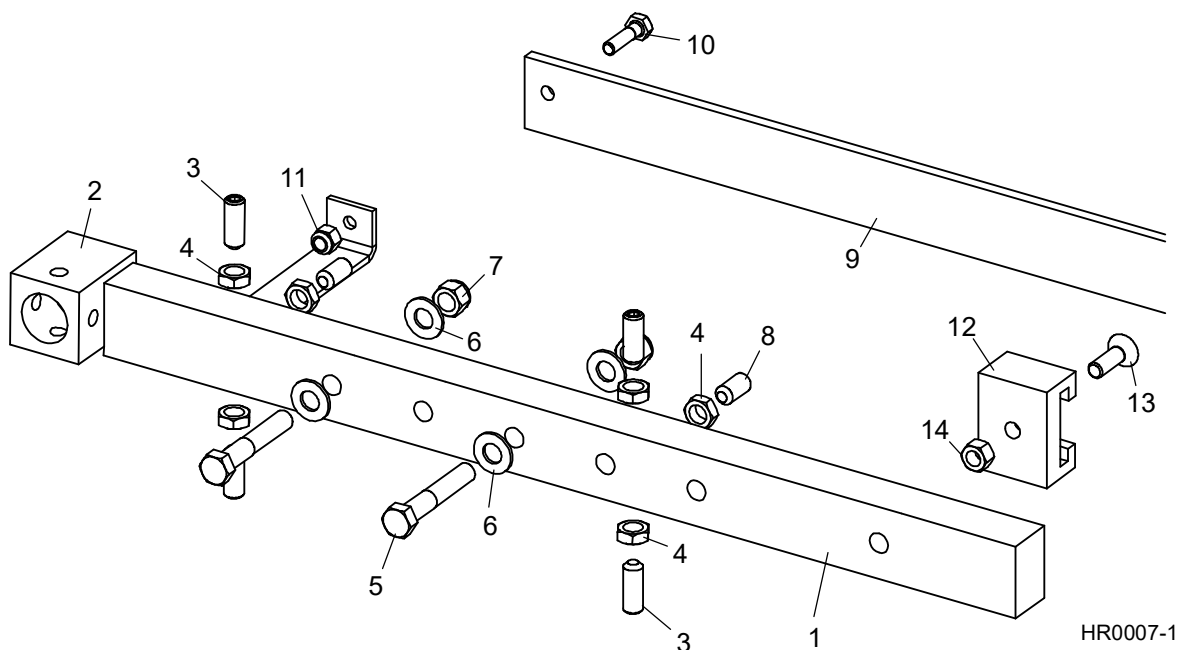

REF	PART #	DESCRIPTION	COMMENTS	QTY.
1	063127	BAR WLDMNT, BLADE GUIDE		1
2	W08159	Tube, Blade Guide Mount		1
3	F05007-184	SCREW, 3/8-24 X 1" FLAT POINT SOCKET HEAD STAINLESS		4
4	F05010-22	NUT, 3/8"-24 HEX JAM		6
5	F05007-201	BOLT, 3/8-16 X 2 1/4" HEX HEAD GRADE 5		2
6	F05011-3	WASHER, 3/8" SAE FLAT		4
7	F05010-10	NUT, 3/8-16 HEX NYLON LOCK		2
8	F05007-95	SCREW, 3/8-24 X 3/4" FLAT POINT SOCKET HEAD STAINLESS		2
9	063194	GUARD, LT15 BLADE GUIDE ARM		1
10	F05005-38	BOLT, 1/4-20 X 1" HEX HEAD GRADE 2		1
11	F05010-69	NUT, 1/4-20 HEX NYLON LOCK		1
12	014882	BLOCK, BLADE GUIDE ARM GUARD GUIDE		1
13	F05006-124	BOLT, 5/16-18 X 1" FLAT HEAD		1
14	F05010-6	NUT, 5/16-18 HEX LOCK		1

SECTION 3 BLADE WHEELS AND TENSIONER

3.1 Blade Drive Assembly

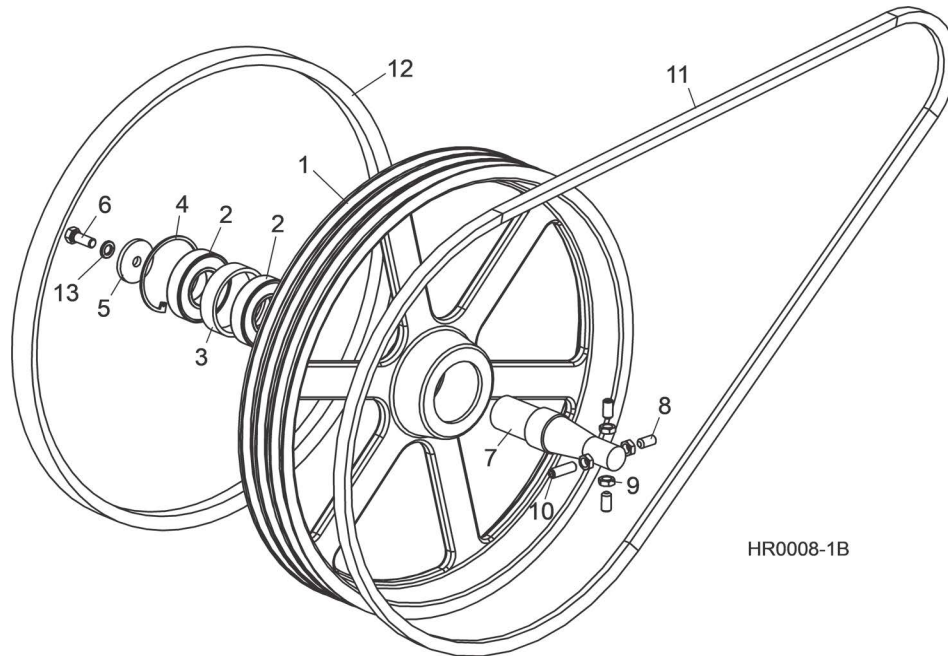

REF	PART #	DESCRIPTION	COMMENTS	QTY.
	014995	WHEEL ASSEMBLY, DRIVE SIDE BLADE (E10/E15)		1
	036657	WHEEL ASSEMBLY, DRIVE SIDE BLADE (G18/G25/D17)		1
1	014727	Wheel, Drive Side Blade (E10/E15)		1
	047702	Wheel, Drive Side Blade (G18/G25/D17)		1
2	014811	Bearing, #6207 2RS		2
3	014730	Spacer, Drive Bearing		1
4	F04254-30	Ring, 3.121 IR Beveled Retaining		1
5	014728	WASHER, DRIVE WHEEL RETAINING		1
6	F05007-87	BOLT, 3/8-16 X 1" HEX HEAD GRADE 5		1
7	014729	SHAFT, LT15 DRIVE SIDE BLADE WHEEL		1
8	F05007-95	SCREW, 3/8-24 X 3/4" FLAT POINT SOCKET HEAD STAINLESS		3
9	F05010-22	NUT, 3/8-24 HEX JAM		4
10	F05007-96	SCREW, 3/8-24 X 1 1/4" FLAT POINT SOCKET HEAD STAINLESS		1
11	P25301	BELT, BX85 (60HZ E10/E15)		1
	P20701	BELT, BX86 (50HZ E15)		1
	047751	BELT, 2/3VFL900 DRIVE (G18/G25/D17)		1

3 Blade Wheels & Tensioner

Blade Drive Assembly

REF	PART #	DESCRIPTION	COMMENTS	QTY.
	017943	BELT, BX87 (G15)		1
12	P04185	BELT, B57		1
13	F05011-4	WASHER, 3/8" SPLIT LOCK		1

3.2 Idle Blade Wheel Assembly

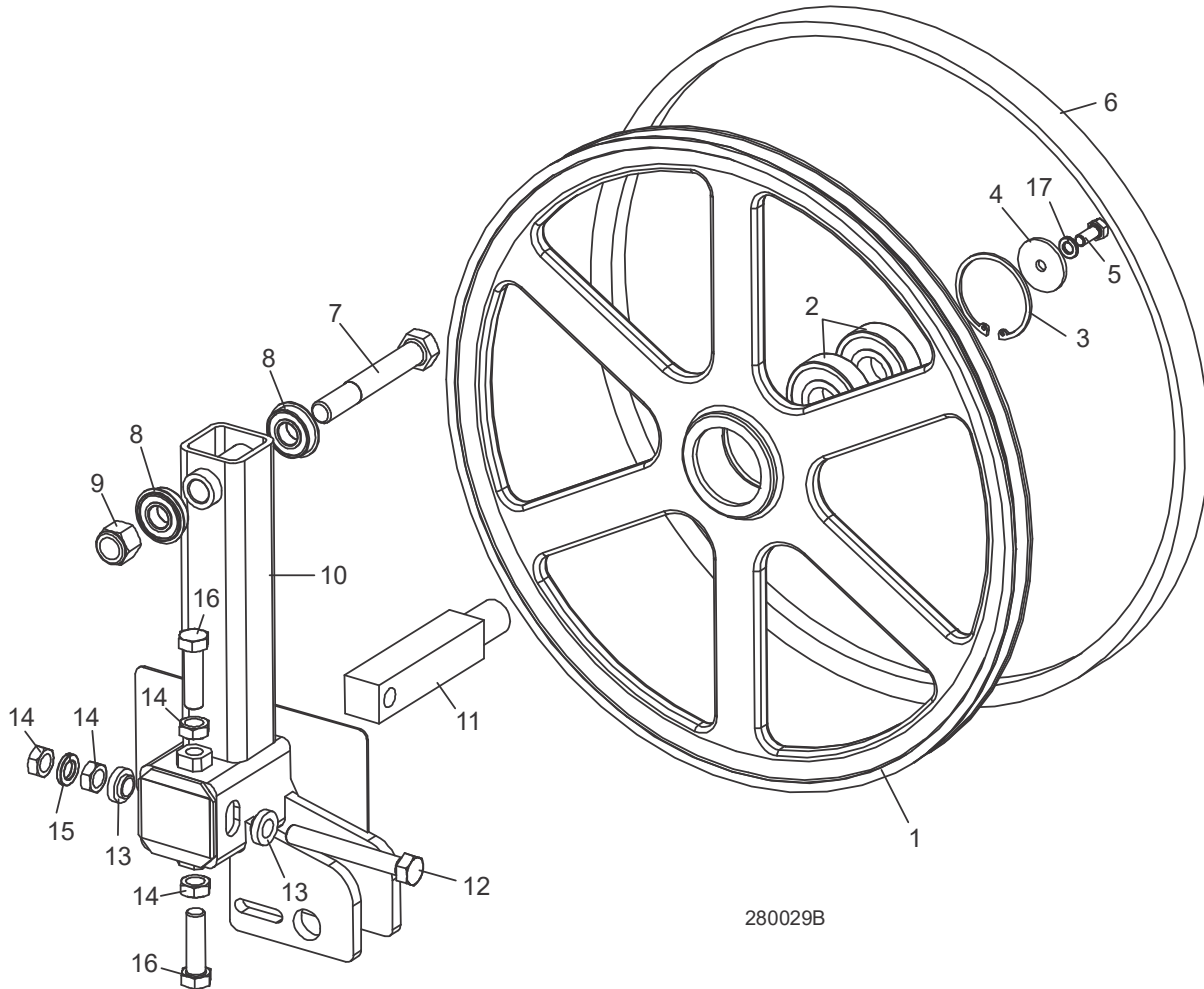

REF	PART #	DESCRIPTION	COMMENTS	QTY.
	A08218	WHEEL ASSEMBY, IDLE SIDE BLADE		1
1	P08125	Wheel, Idle Side Blade	Available in assemblies only.	1
2	P08066	Bearing, Idle Side Blade Wheel #6305-AA, C3, ABEC-1, SRI-2 Grease		2
3	F04254-21	Ring, 2 7/16" Internal Retaining		1
4	S08220	WASHER, IDLE BLADE WHEEL RETAINER		1
5	F05006-102	BOLT, 5/16-18 X 3/4" HEX HEAD		1
6	P04185	BELT, BLADE WHEEL B57		1
7	F05009-3	BOLT, 5/8-11 X 4 1/2" HEX HEAD		1
8	014834	BEARING, 5/8" I.D. W/SNAP RING		2
9	F05010-34	NUT, 5/8-11 HEX NYLON LOCK		1
10	049349	IDLER WELDMENT, BLADE WHEEL		1
11	S12565	SHAFT, IDLE WHEEL		1

3**Blade Wheels & Tensioner***Idle Blade Wheel Assembly*

REF	PART #	DESCRIPTION	COMMENTS	QTY.
12	F05008-111	BOLT, 1/2-20 X 3 3/4" HEX HEAD FULL THREAD GRADE 2		1
13	S04253	SPACER, 1/2" I.D. FLANGED		2
14	F05010-16	NUT, 1/2-20 HEX JAM		4
15	F05011-9	WASHER, 1/2" SPLIT LOCK		1
16	F05008-127	BOLT, 1/2-20 X 1 3/4" HEX HEAD GRADE 5		2

3.3 Blade Tensioner Assembly

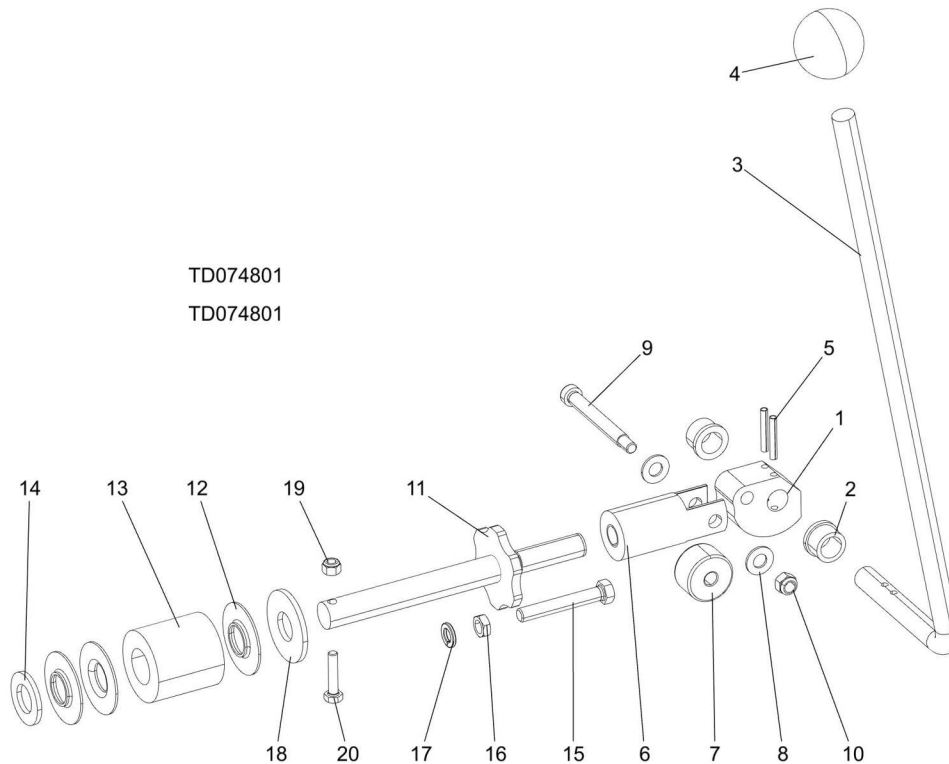

TD074801
TD074801

REF	PART #	DESCRIPTION	COMMENTS	QTY.
	074801	TENSION ASSEMBLY, CAM ACTUATED BLADE	LT15/28/35, HR120/130	1
1	049104	Cam, Tension		1
2	P05135	Bushing, 5/8" x 7/8" x 1/2" Bronze		2
3	103801	Handle, Blade Tensioner, LT15/28/35		1
4	P04211	Knob, 5/8-18 Ball		1
5	F05012-16	Pin, 3/16" x 1 1/4" Roll		2
6	049321	Block, Tensioner Bearing Mount		1
7	048219	Cam Follower, 3/8" x 1 3/8" x 13/16"		1
8	F05011-3	Washer, 3/8" SAE Flat		2
9	F05007-202	Bolt, 3/8 x 2 1/2" Socket Head Shoulder		1
10	F05010-58	Nut, 5/16-18 Hex Nylon Lock		1
11	038642	Shaft Weldment, Blade Tension		1
12	014925	Guide, Tension Handle		3
13	014828	Spring, Rubber Tensioner Blade		1
14	F05011-62	Washer, 3/4" SAE Flat		1
15	F05007-157	Bolt, 3/8-16 x 2 1/2" Hex Head Full Thread		1
16	F05010-29	Nut, 3/8-16 Jam		1
17	F05011-4	Washer, 3/8" Split Lock		1



Blade Wheels & Tensioner

Blade Tensioner Assembly

REF	PART #	DESCRIPTION	COMMENTS	QTY.
18	F05011-29	Washer, 3/4" USS Flat		1
19	F05010-69	Nut, 1/4-20 Nylock		1
20	F05005-116	Bolt, 1/4-20x1 1/4 HH Gr5		1

SECTION 4 SAW HEAD ASSEMBLIES

4.1 Blade Housing Covers & Wood Blocks

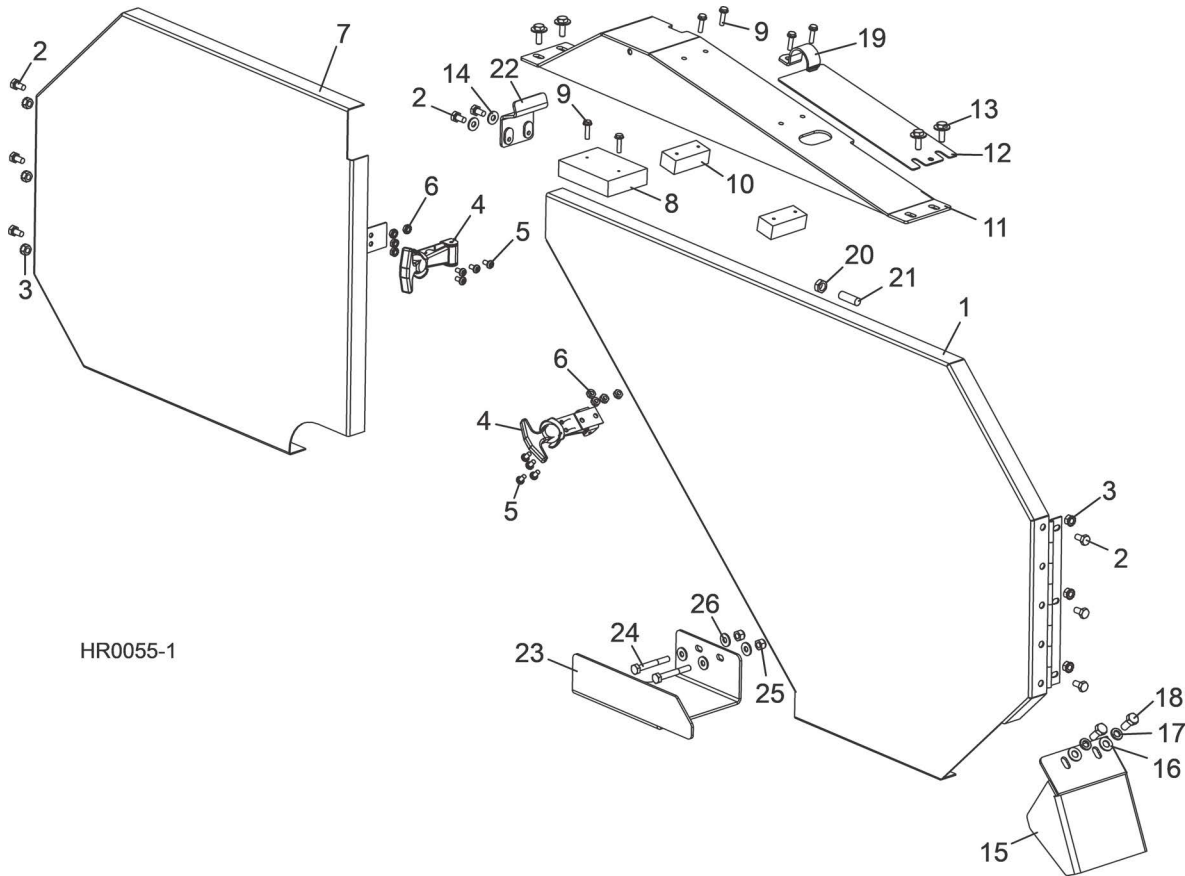

REF	PART #	DESCRIPTION	COMMENTS	QTY.
1	065072	COVER, DRIVE SIDE HR120 BLADE HOUSING	INCLUDES COVER DECALS - See Section 4.3	1
	065317	COVER, DRIVE SIDE HR130 BLADE HOUSING	INCLUDES COVER DECALS - See Section 4.3	1
2	F05005-15	BOLT, 1/4-20 X 1/2" HEX HEAD		8
3	F05010-9	NUT, 1/4-20 KEPS		6
4	014829	LATCH, FLEXIBLE DRAW		2
5	F05004-3	SCREW, #10-24 X 3/8" CROSS SLOTTED ROUND HEAD		8
6	F05010-14	NUT, #10-24 SELF-LOCKING HEX		8
7	065073	COVER, IDLE SIDE HR120 BLADE HOUSING	INCLUDES COVER DECALS - See Section 4.3	1
	065075	COVER, IDLE SIDE HR130 BLADE HOUSING	INCLUDES COVER DECALS - See Section 4.3	1

4

Saw Head Assemblies*Blade Housing Covers & Wood Blocks*

REF	PART #	DESCRIPTION	COMMENTS	QTY.
8	015844	BLOCK, BLADE VIBRATION DAMPENING		1
9	F05015-33	BOLT, #10 X 3/4" SLOTTED HEX WASHER HEAD		6
10	016506	BLOCK, 3/4" X 1" X 2" WOOD	E10/E15 Only.	2
	038633	COVER ASSEMBLY, TOP ENGINE PULLEY		1
11	074574	Cover Weldment, LT15/28 Top Belt Cover		1
12	074546	Plate, Belt Guard Cover		1
13	F05005-134	Bolt, 1/4-20 x 3/4" Hex Head w/Conical Washer		4
14	F05011-11	WASHER, 1/4" SAE FLAT		2
15	003811	PLATE, SAWDUST DEFLECTOR		1
16	F05011-17	WASHER, 5/16" SAE FLAT		2
17	F05011-13	WASHER, 5/16" SPLIT LOCK		2
18	F05006-5	BOLT, 5/16-18 X 3/4" HEX HEAD		2
19	P05436	CLAMP, 1" EMT (E10 ONLY)		1
20	F05010-29	NUT, 3/8-16 JAM		1
21	F05007-18	SCREW, 3/8-16 X 1 1/4 SHOP SET		1
22	074394	BRACKET WELDMENT, LT15 BELT ENHANCE		1
	079320	GUARD ASSEMBLY, HR120/130 DRIVE SIDE BLADE		1
23	079319	Plate, HR120/130 Drive Side Blade Guard		1
24	F05005-125	Bolt, 1/4-20x2 Hex Head Grade 5		2
25	F05010-69	Nut, 1/4-20 Nylock		2
26	F05011-11	Washer, 1/4 SAE Flat		4
	015849	Decal, LT15 Blade Guide Bar		0.3

4 Saw Head Assemblies

Water Lube Assembly

4.2 Water Lube Assembly

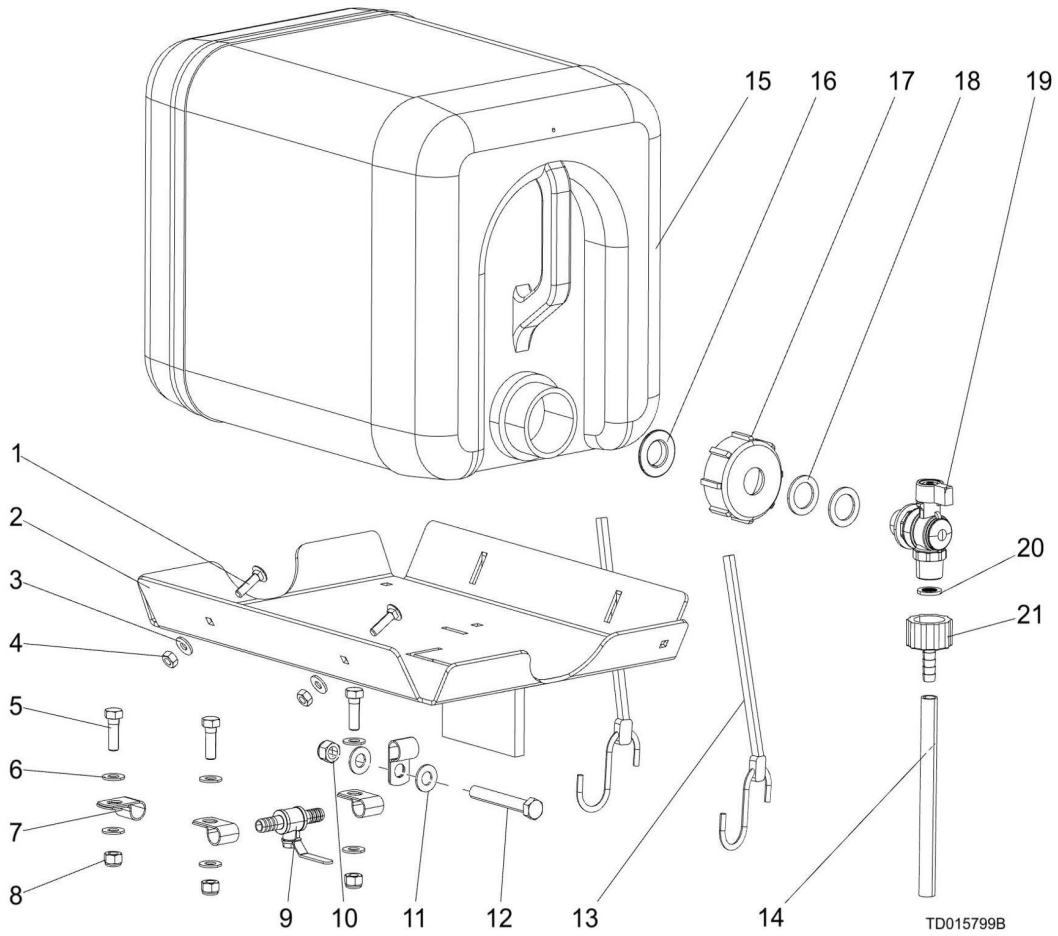

REF	PART #	DESCRIPTION	COMMENTS	QTY.
	015799	WATER LUBE ASSEMBLY		1
1	F05005-34	Bolt, 1/4-20 X 1 Carr		2
2	015798	Tray Weldment, Water Bottle LT15		1
3	F05011-11	Washer, 1/4 SAE Flat		2
4	F05010-21	Nut, 1/4-20 Swaged		2
5	F05006-1	Bolt, 5/16-18x1 HH Gr2		3
6	F05011-17	Washer, 5/16 SAE Flat		6
7	P07584	Clamp, 1/2EMT Coated		4
8	F05010-58	Nut, 5/16-18 Nyl Lock		3
9	065635	Valve, 1/4Turn Ball 3/8 Hose Barbs		1
10	F05010-10	Nut, 3/8-16 Hex Nyl Lock		1
11	F05011-3	Washer, 3/8 Flat SAE		2
12	F05007-230	Bolt, 3/8-16x2 3/4 FT Gr5		1
13	P11668	Strap, 20 Rubber W/Hooks		2
14	R01885	Hose, Water Lube Stock		12.83'

REF	PART #	DESCRIPTION	COMMENTS	QTY.
	601615	Assembly, Water Bottle		1
15	513866	Bottle, Water		1
		Assembly, Cap w/ Valve		
16	625839	Nut, Brass 1/2" for Water Bottle		1
17	550785	Cap, Water Bottle		1
18	550780	O-Ring, 20X30X2		2
19	625845	Valve	Available in assembly only	1
20	550778	Gasket, 1/2" w/Strainer		1
21	550777	Fitting, G3/4" X 10mm Hose Barb		1

4.3 Saw Head Decals

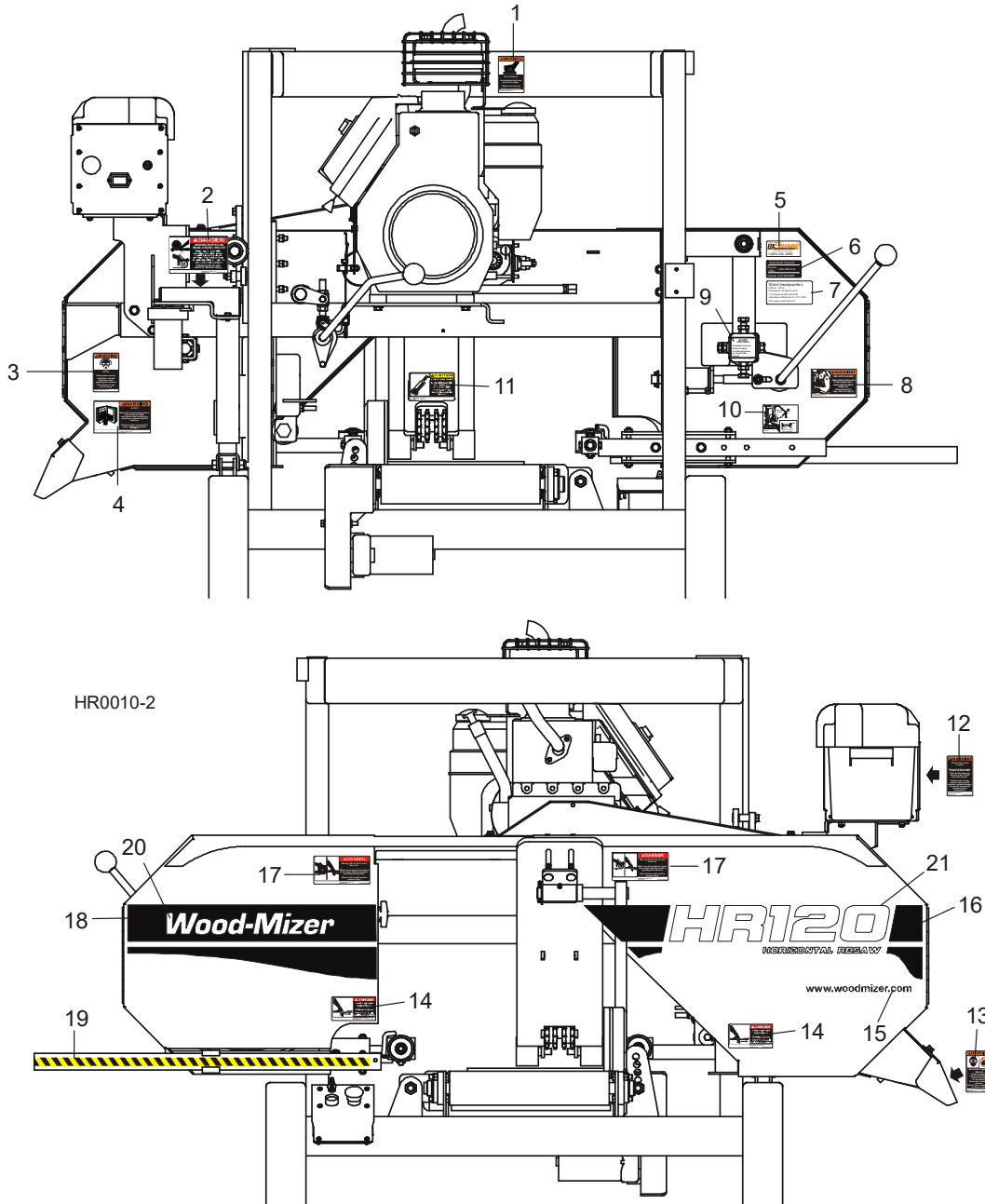

REF	PART #	DESCRIPTION	COMMENTS	QTY.
1	014419	DECAL, HOT ENGINE WARNING		1
2	028720	DECAL, MOVING PARTS DANGER		1
3	S11753	DECAL, EYE/EAR PROTECTION WARNING		1
4	016402	DECAL, READ MANUAL WARNING		1
5	P12879	DECAL, RESHARP INFO		1
6	S12117	DECAL, TOLL FREE PARTS		1
7	015840	DECAL, WORLD HEADQUARTERS ADDRESS		1
8	049367	DECAL, TENSIONER WARNING		1
9	P11789	DECAL, BLADE TRACK INFO		1
10	049368	DECAL, BLADE TENSION INFO		1
11	063189	DECAL, ADJUST HOLD-DOWN CAUTION		1
12	P10364	DECAL, 12V ELECTRICAL SYSTEM WARNING		1

REF	PART #	DESCRIPTION	COMMENTS	QTY.
13	P11754	DECAL, SAWDUST CHUTE WARNING		1
14	S11752	DECAL, BLADE DANGER		2
15	003235	DECAL, WOOD-MIZER WEBSITE LOGO		1
16	065385	DECAL, DRIVE SIDE EURO-STRIPE BK HR120		1
17	033254	DECAL, MOVING PARTS DANGER		2
18	065008	DECAL, IDLE SIDE EURO-STRIPE BK 15/28/35		1
19	015849	DECAL, BLADE GUIDE ARM STRIPE		1
20	065002	DECAL, WOOD-MIZER LOGO WHT LT10/15/28/35		1
21	062721	DECAL, HR120 EURO LOGO WHITE		1

SECTION 5 CONTROL & BATTERY BOXES

5.1 Battery Box Assembly

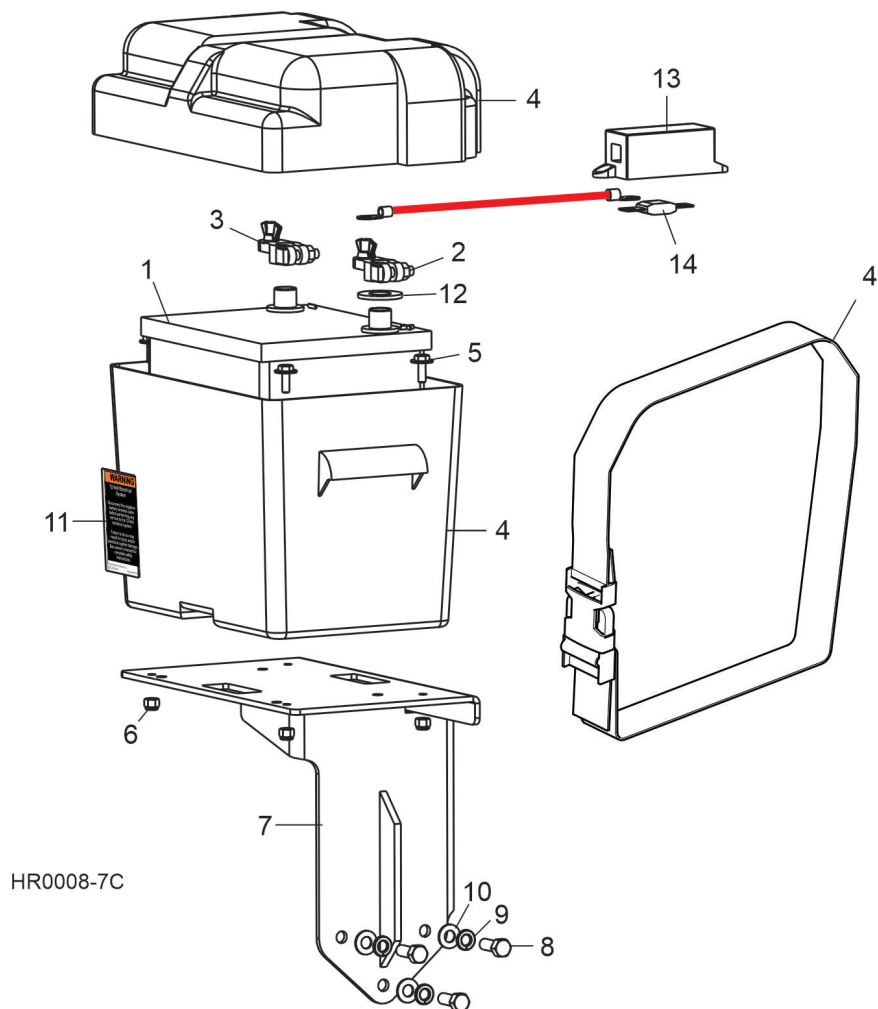

REF	PART #	DESCRIPTION	COMMENTS	QTY.
	034609	BATTERY MODULE, HR120 G18/G25/D17		1
1	028004	Battery, 12 Volt 600U	Available in assemblies only.	1
2	033358	Terminal, Positive Battery		1
3	033359	Terminal, Negative Battery		1
4	016413	Box Assembly, LT15 Battery		1
5	F05005-134	Bolt, 1/4-20x 3/4" W/Conical Washer		4
6	F05010-69	Nut, 1/4-20 Hex Nylon Lock		4
7	034899	Mount Weldment, Battery/Control Box		1
8	F05007-7	Bolt, 3/8-16 x 1" Hex Head		3
9	F05011-4	Washer, 3/8" Split		3
10	F05011-3	Washer, 3/8" SAE Flat		3
11	P10364	Decal, 12V Warning		1
12	P12161	Washer, Felt Battery Terminal		1
	052372	FUSEHOLDER ASSEMBLY, MEGA FUSE 150A		1
13	052371	Fuseholder, Mega Fuse		1
14	052370-150	Fuse, 150A Mega		1

5.2 Feed Control Box Assembly (HR120G18/G25)

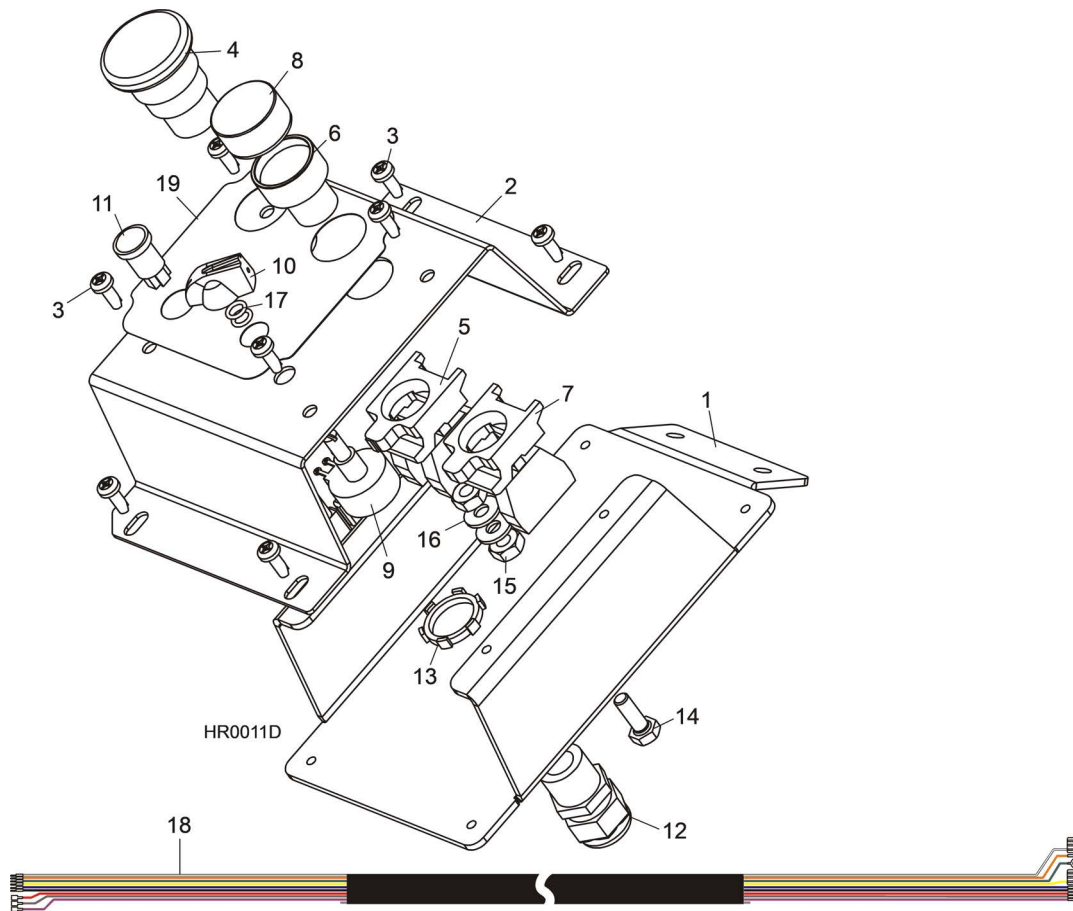

REF	PART #	DESCRIPTION	COMMENTS	QTY.
	053569	CONTROL ASSEMBLY, HR120 G18/G25 FEED		1
1	053567	Plate, HR120 Feed Control Base		1
2	053568	Plate, HR120 Feed Control Face		1
3	F05015-17	Screw, #10-24 x 1/2" Phillips Pan Head Type 23		8
4	024945	Operator, 22mm ZB4 Red Maintained E-Stop Push Button		1
5	050527	Base, 1 NC 1 NO Contact ZB4		1
6	050152	Switch Head, Green Guarded		1
7	025242	Switch Body, 1NO 22mm ZB4		1
8	053678	Boot, 22mm Round Sealing Push Button		1
9	053572	Switch Assembly, HR120 Feed Rate Pot		1
10	P06257	Knob, Speed Control		1
11	E20483	Light, Green 12V .187 Tabs		1
12	051299	Connector, 1/2" NPT .17 - .47 Cord Grip		1
13	E20461	Nut, 1/2" Connector Lock		1
14	F05005-1	Bolt, 1/4-20 x 3/4" Hex Head Full Thread		1
15	F05010-129	Nut, 1/4-20 Heavy Duty Hex Jam		2
16	F05011-11	Washer, 1/4" SAE Flat		2
17	033476	O-Ring, 7/32" ID #009		2
18	053573	Harness, HR120 G18/G25 Operator		1
19	053570	Decal, HR120 Feed Control		1

5.3 Feed Control Box Assembly (HR120D17)

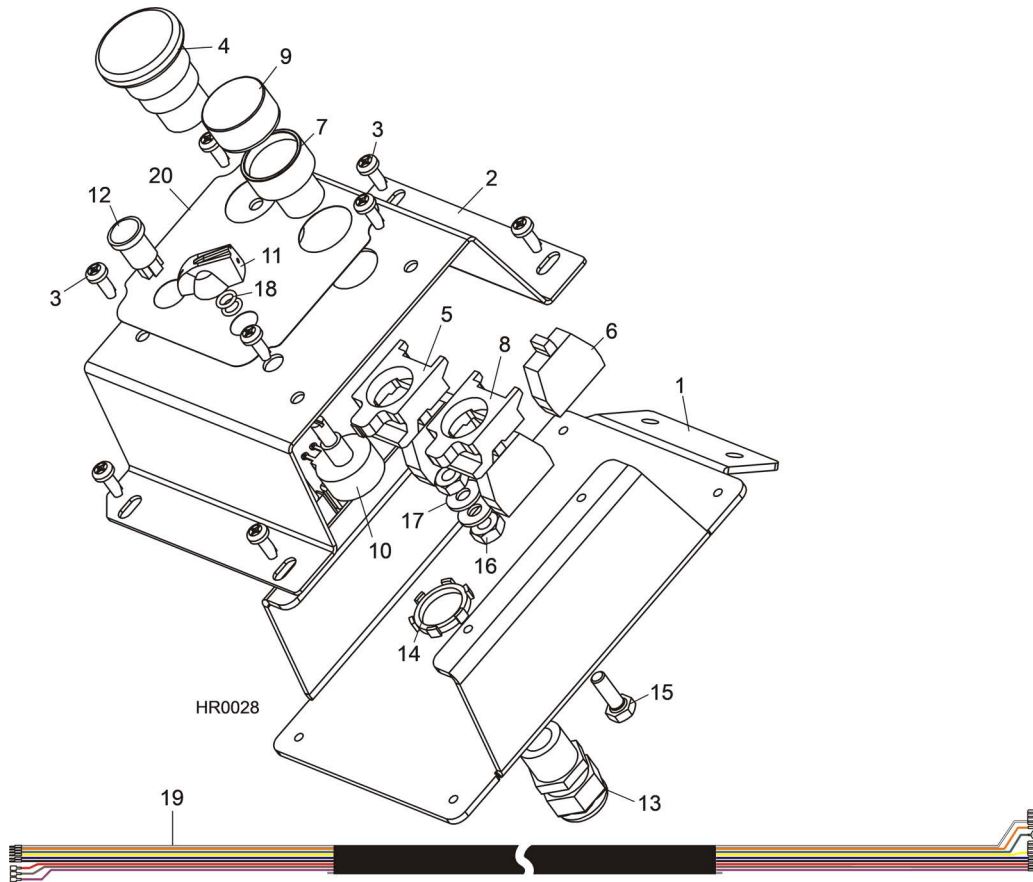

REF	PART #	DESCRIPTION	COMMENTS	QTY.
	069301	CONTROL ASSEMBLY, HR120 D18 FEED		1
1	053567	Plate, HR120 Feed Control Base		1
2	053568	Plate, HR120 Feed Control Face		1
3	F05015-17	Screw, #10-24 x 1/2" Phillips Pan Head Type 23		8
4	024945	Operator, 22mm ZB4 Red Maintained E-Stop Push Button		1
5	025161	Base, 1 NC Contact ZB4		1
6	050540	Contact, NC ZBE102		1
7	050152	Switch Head, Green Guarded		1
8	025242	Switch Body, 1NO 22mm ZB4		1
9	053678	Boot, 22mm Round Sealing Push Button		1
10	053572	Switch Assembly, HR120 Feed Rate Pot		1
11	P06257	Knob, Speed Control		1
12	E20483	Light, Green 12V .187 Tabs		1
13	051299	Connector, 1/2" NPT .17 - .47 Cord Grip		1
14	E20461	Nut, 1/2" Connector Lock		1
15	F05005-1	Bolt, 1/4-20 x 3/4" Hex Head Full Thread		1
16	F05010-129	Nut, 1/4-20 Heavy Duty Hex Jam		2
17	F05011-11	Washer, 1/4" SAE Flat		2
18	033476	O-Ring, 7/32" ID #009		2
19	053690	Harness, HR120 D18 Operator		1
20	053570	Decal, HR120 Feed Control		1

5.4 Feed Control Box Assembly (HR120E10)

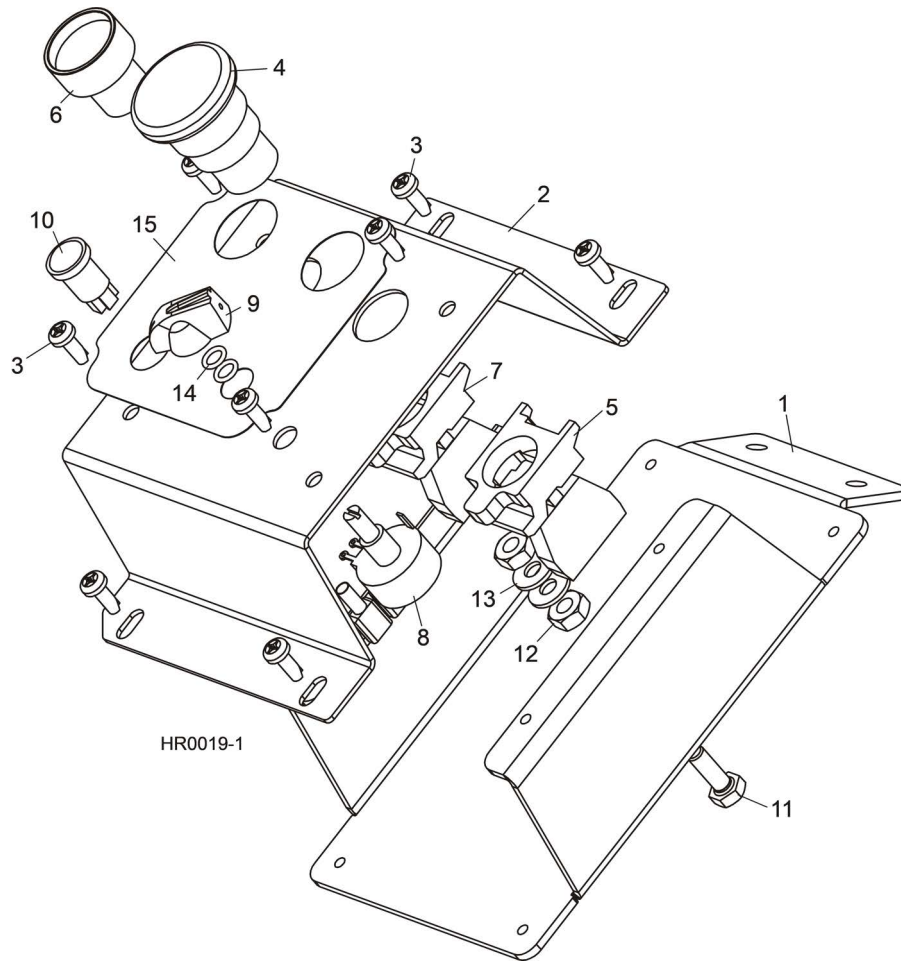

REF	PART #	DESCRIPTION	COMMENTS	QTY.
	053637	CONTROL ASSEMBLY, HR120 E10 FEED		1
1	053567	Plate, HR120 Feed Control Base		1
2	053568	Plate, HR120 Feed Control Face		1
3	F05015-17	Screw, #10-24 x 1/2" Phillips Pan Head Type 23		8
4	024945	Operator, 22mm ZB4 Red Maintained E-Stop Push Button		1
5	025161	Base, 1 NC 22mm ZB4		1
6	050152	Switch Head, Green Guarded		1
7	025242	Switch Body, 1NO 22mm ZB4		1
8	053572	Switch Assembly, HR120 Feed Rate Pot		1
9	P06257	Knob, Speed Control		1
10	E20483	Light, Green 12V .187 Tabs		1
11	F05005-1	Bolt, 1/4-20 x 3/4" Hex Head Full Thread		1
12	F05010-129	Nut, 1/4-20 Heavy Duty Hex Jam		2
13	F05011-11	Washer, 1/4" SAE Flat		2
14	033476	O-Ring, 7/32" ID #009		2
15	053608	Decal, HR120 E10 Feed Control		1

5.5 Up/Down Control Box Assembly (G18/G25)

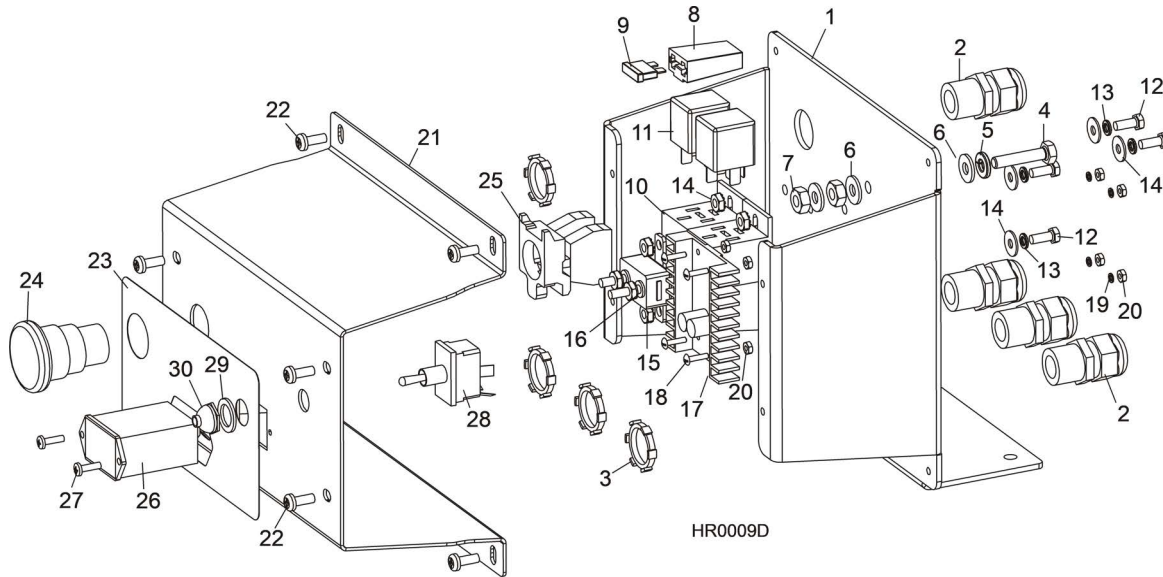

REF	PART #	DESCRIPTION	COMMENTS	QTY.
	053581	CONTROL ASSEMBLY, HR120G18 UP/DOWN		1
	053582	CONTROL ASSEMBLY, HR120G25 UP/DOWN		1
1	063181	Plate, Up/Down Control Base		1
2	051299	Connector, 1/2" NPT .17 - .47 Cord Grip		4
3	E20461	Nut, 1/2" Connector Lock		4
4	F05005-3	Bolt, 1/4-20 x 1 1/4" Hex Head Full Thread		1
5	F05011-14	Washer, 1/4" Split Lock		1
6	F05011-11	Washer, 1/4" SAE Flat		3
7	F05010-129	Nut, 1/4-20 Heavy Duty Hex Jam		2
8	052354	Fuseholder, ATO 16 GA Red SXL 20" Wires		1
9	024150-4	Fuse, 4A ATO Pink Blade		1
10	050033	Socket, Relay Plug		2
11	051335	Relay, ISO 12V Coil w/Diode		2
12	F05004-27	Bolt, #10-24 x 1/2" Indented Hex Head Stainless Steel		4
13	F05011-20	Washer, #10 Split Lock		4
14	F05011-18	Washer, #10 SAE Flat		4
15	F05010-14	Nut, #10-24 Self-Locking Hex		4
16	E20431	Breaker, 30A Manual Reset Circuit		1
17	057829-FR	Driver Kit, 25A DC Motor Field Replacement		1
18	F05004-14	Screw, #4-40 x 1/2" Slotted Round Head		4
19	F05011-21	Washer, #4 Split Lock		4
20	F05010-43	Nut, #4-40 Hex		8
21	063180	Plate, Up/Down Control Front		1
22	F05015-17	Bolt, #10-24 x 1/2" Phillips Pan Head Type 23		8
23	053571	Decal, HR120 Up/Down Control Box		1
24	024945	Operator, 22mm ZB4 Red Maintained E-Stop Push Button		1
25	050527	Base, 1 NC 1 NO Contact ZB4		1

REF	PART #	DESCRIPTION	COMMENTS	QTY.
26	015401	Meter, Rectangle Mount Hour		1
27	F05015-28	Screw, #6-32 x 1/2" Phillips Pan Head Type 23		2
28	024200	Switch, DPDT 21A Reverse Momentary Spade Toggle		1
29	P05251-1	Washer, 1/2" ID x 3/4" OD x 1/16" Nylon		1
30	P02575	Boot, Toggle Switch		1

5.6 Up/Down Control Box Assembly (D17)

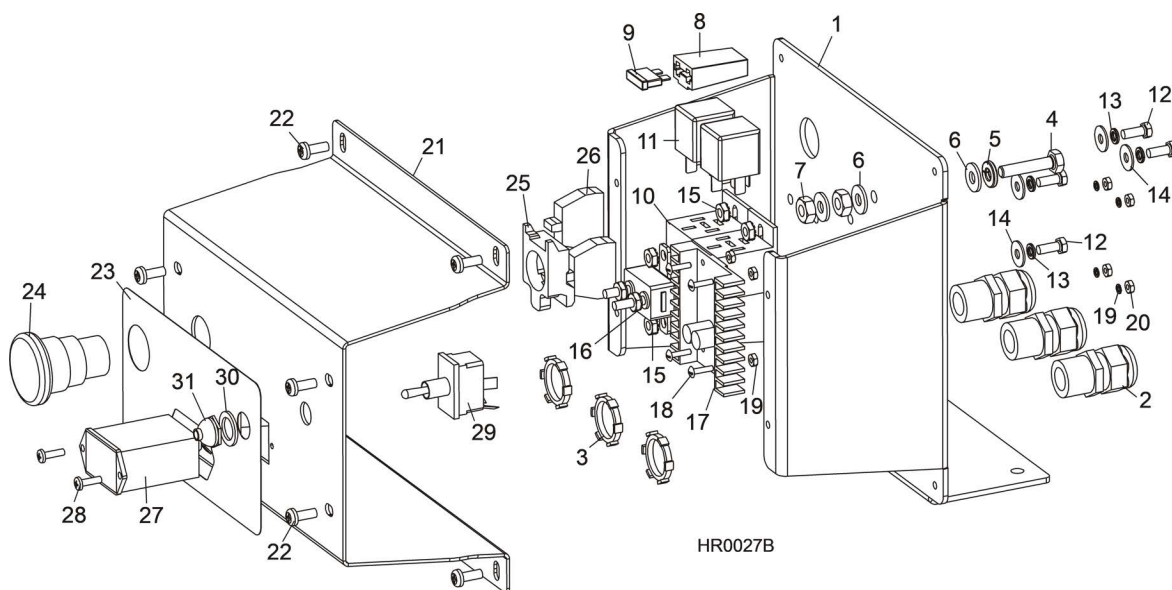

REF	PART #	DESCRIPTION	COMMENTS	QTY.
	069300	CONTROL ASSEMBLY, HR120 D17 UP/DOWN		1
1	063181	Plate, Up/Down Control Base		1
2	051299	Connector, 1/2" NPT .17 - .47 Cord Grip		4
3	E20461	Nut, 1/2" Connector Lock		4
4	F05005-3	Bolt, 1/4-20 x 1 1/4" Hex Head Full Thread		1
5	F05011-14	Washer, 1/4" Split Lock		1
6	F05011-11	Washer, 1/4" SAE Flat		3
7	F05010-129	Nut, 1/4-20 Heavy Duty Hex Jam		2
8	052354	Fuseholder, ATO 16 GA Red SXL 20" Wires		1
9	024150-4	Fuse, 4A ATO Pink Blade		1
10	024319	Socket, Relay Stackable		2
	073826	TPA, Delphi 5 Pos	Terminal position assurance locks not shown.	2
11	051335	Relay, ISO 12V Coil w/Diode		2
12	F05004-27	Bolt, #10-24 x 1/2" Indented Hex Head Stainless Steel		4
13	F05011-20	Washer, #10 Split Lock		4
14	F05011-18	Washer, #10 SAE Flat		4
15	F05010-14	Nut, #10-24 Self-Locking Hex		4
16	E20431	Breaker, 30A Manual Reset Circuit		1
17	057829-FR	Driver Kit, 25A DC Motor Field Replacement		1
18	F05004-14	Screw, #4-40 x 1/2" Slotted Round Head		4
19	F05011-21	Washer, #4 Split Lock		4
20	F05010-43	Nut, #4-40 Hex		8
21	063180	Plate, Up/Down Control Front		1
22	F05015-17	Bolt, #10-24 x 1/2" Phillips Pan Head Type 23		8
23	053571	Decal, HR120 Up/Down Control Box		1
24	024945	Operator, 22mm ZB4 Red Maintained E-Stop Push Button		1

REF	PART #	DESCRIPTION	COMMENTS	QTY.
25	025161	Base, 1 NC Contact ZB4		1
26	050540	Contact, NC ZBE102		1
27	015401	Meter, Rectangle Mount Hour		1
28	F05015-28	Screw, #6-32 x 1/2" Phillips Pan Head Type 23		2
29	024200	Switch, DPDT 21A Reverse Momentary Spade Toggle		1
30	P05251-1	Washer, 1/2" ID x 3/4" OD x 1/16" Nylon		1
31	P02575	Boot, Toggle Switch		1

5.7 Up/Down Control Box Assembly (HR120E10/HR120EA10)

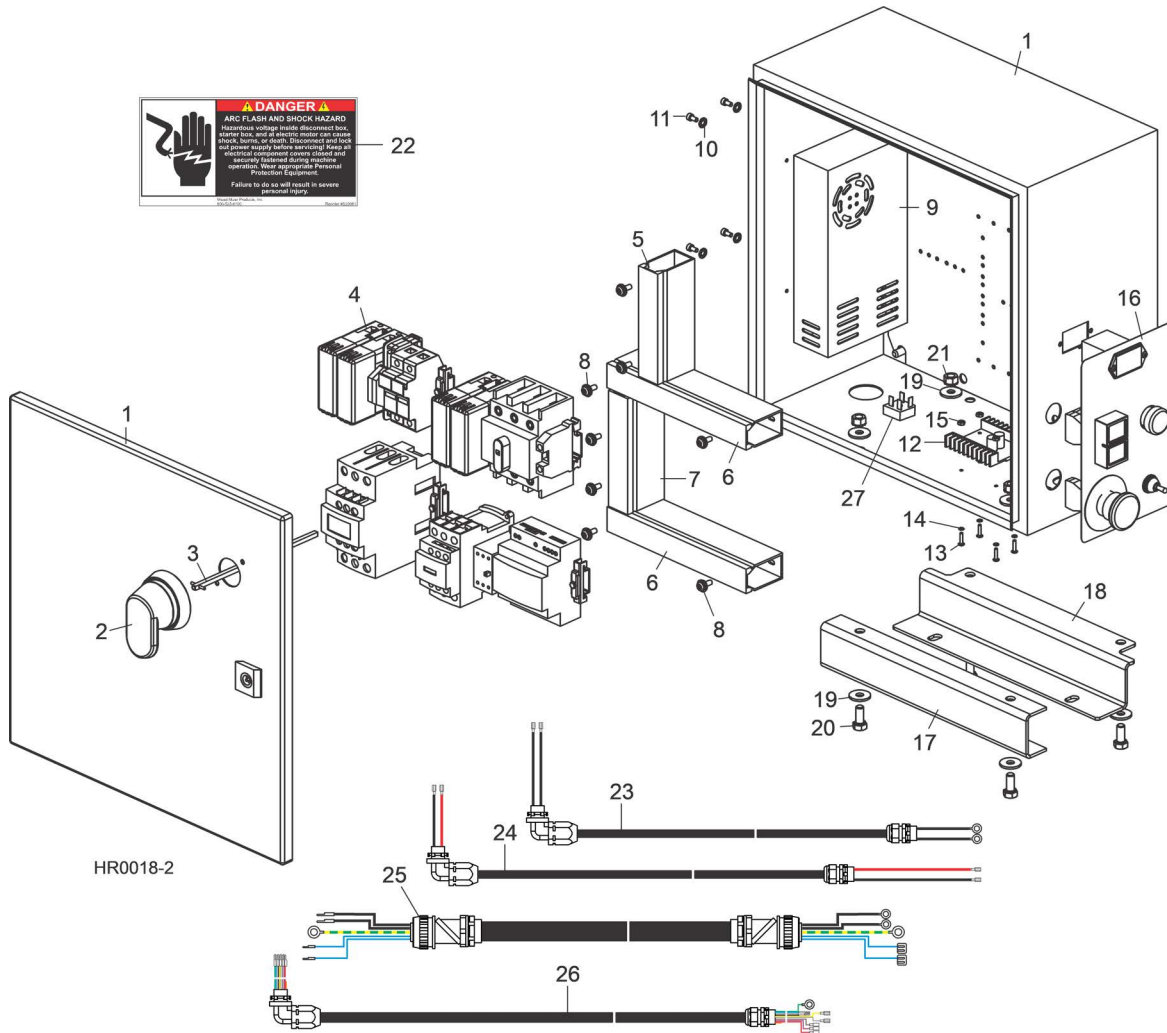

REF	PART #	DESCRIPTION	COMMENTS	QTY.
	053596	CONTROL ASSEMBLY, HR120EA10		1
1	053584	Enclosure, 16" x 16" x 8" Custom Electrical		1
2	050907-1	Handle, Red/Yellow Pistol Grip Operator 6mm		1
3	050908-1	Shaft, 290mm x 6mm Disconnect (Modified to 7")		1
4		Insert Panel Parts	<i>(See Section 5.12)</i>	
5	024472	Cable Duct, 2" x 1" x 6' Open Slot Gray		.069 Ft.
6	024472	Cable Duct, 2" x 1" x 6' Open Slot Gray		.111 Ft.
7	024472	Cable Duct, 2" x 1" x 6' Open Slot Gray		.073 Ft.
8	F05004-186	Screw, #10-24 x 1/2" Phillips Head		8
9	053592	Power Supply, 12VDC 320W Chassis Mount		1
10	F05011-57	Washer, 4mm Split Lock		4
11	F05004-255	Screw, M4-.7 x 8mm Socket Head		4
12	057829-1	Driver, 25A DC Motor w/Spade Terminals		1
13	F05004-14	Screw, #4-40 x 1/2" Slotted Round Head		4
14	F05011-21	Washer, #4 Split Lock		4
15	F05010-43	Nut, #4-40 Hex		4

REF	PART #	DESCRIPTION	COMMENTS	QTY.
16		Control Panel Parts	See <i>Electrical Information</i> in Online Manuals	
17	035991	Bracket, Front Mounting		1
18	035992	Bracket, Rear Mounting		1
19	F05011-16	Washer, 5/16" Standard Flat		4
20	F05006-5	Bolt, 5/16-18 x 3/4" Hex Head		4
21	F05010-20	Nut, 5/16-18 Self-Locking Hex		4
22	S20061	Decal, Electrical Hazard Danger		1
23	053593	Harness Assembly, HR120EA10 Feed Motor		1
24	053594	Harness Assembly, HR120EA10 Up/Down Motor		1
25	053589	Harness Assembly, HR120EA10 Blade Motor		1
26	053595	Harness Assembly, HR120EA10 Operator Control		1
27	E10456	Rectifier, 200 PIV 35A Bridge		1

5.8 Control Panel Components (HR120EA10)

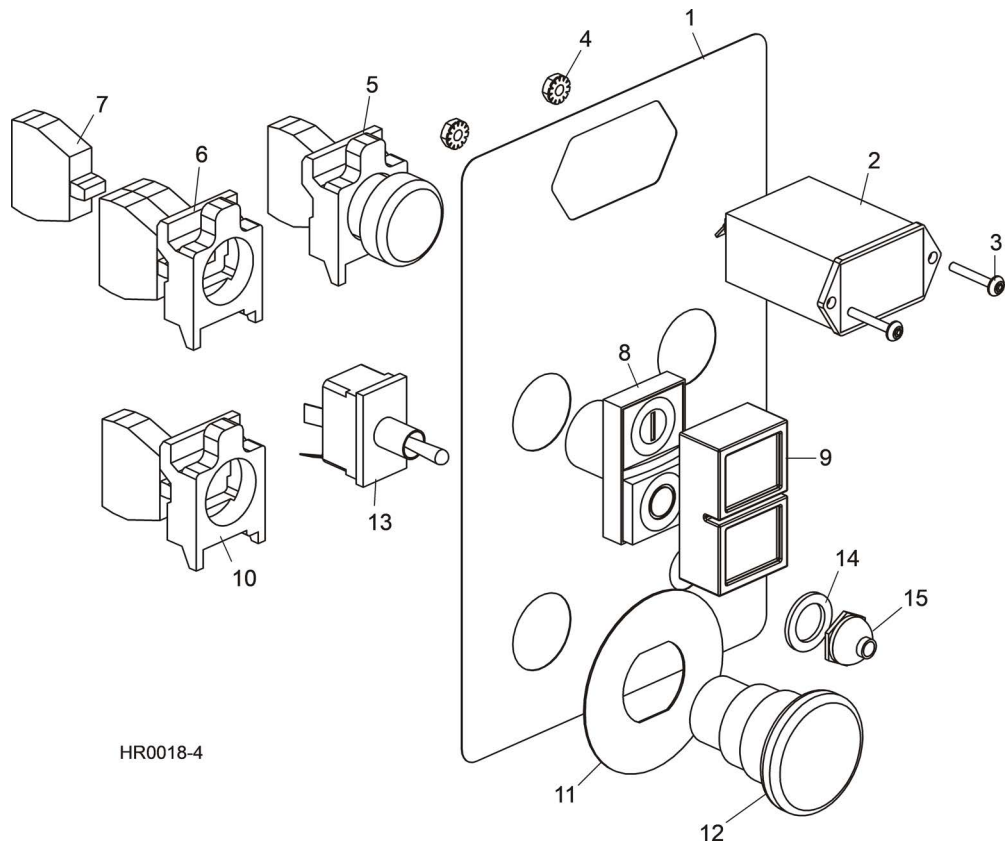

HR0018-4

REF	PART #	DESCRIPTION	COMMENTS	QTY.
1	053626	DECAL, 1PH E10 CONTROL CABINET OPERATION		1
2	015401	METER, RECTANGE MOUNT HOUR		1
3	F05004-93	SCREW, #6-32 X 3/4" STAINLESS SOCKET BUTTON HEAD		2
4	F05010-69	NUT, #6-32 SELF-LOCKING HEX		2
5	024970-3	LIGHT, G433N 24V 22MM LED XB4 PILOT		1
6	025236-31	SWITCH BODY, 22MM GREEN LED 1NO 24V ZB4		1
7	050540	CONTACT, NC ZBE102		1
8	051746	SWITCH OPERATOR, 2 BUTTON W RED/GREEN PILOT		1
9	052501	BOOT, CLEAR ZB SWITCH SEALING		1
10	025161	SWITCH BODY, 1NC 22MM ZB4		1
11	050992	LEGEND, EMERGENCY STOP		1
12	024945	SWITCH OPERATOR, RED 22MM ZB4 RED MAINTAINED E-STOP		1
13	024200	SWITCH, DPDT 21A REV MOMENTARY SPADE TOGGLE		1
14	P05251-1	WASHER, 1/2" ID X 3/4" OD X 1/16" NYLON		1
15	P02575	BOOT, TOGGLE SWITCH		1

5.9 Control Insert Components (HR120EA10)

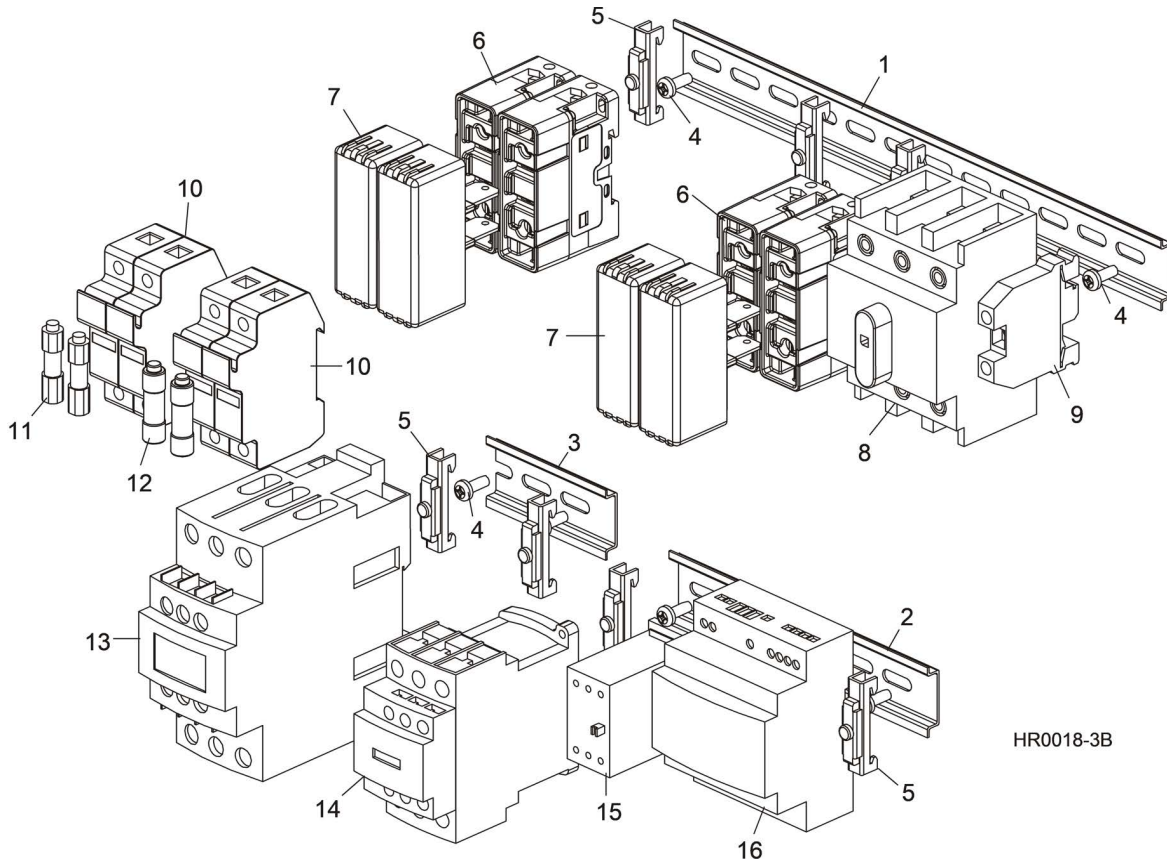

HR0018-3B

REF	PART #	DESCRIPTION	COMMENTS	QTY.
1	024474-12	DIN RAIL, 35MM X 7.5MM X 1M STEEL SYMMET- RICAL		.17 Ft.
2	024474-6	DIN RAIL, 35MM X 7.5MM X 1M STEEL SYMMET- RICAL		.090 Ft.
3	024474-3	DIN RAIL, 35MM X 7.5MM X 1M STEEL SYMMET- RICAL		.042 Ft.
4	F05015-17	SCREW, #10-24 X 1/2" PHILLIPS PAN HEAD TYPE 23		8
5	E22707	CLAMP, PLASTIC DIN RAIL		7
6	053586	FUSEHOLDER, 100A CUBE		4
7	053587	FUSE, 80A CLASS J CUBE		4
8	050906-1	DISCONNECT, 100A 3PH NON-FUSED		1
9	053585	TERMINAL BLOCK, GROUNDING		1
10	052512	FUSE BLOCK, 2P CLASS CC 30A DIN		2
11	E22716	FUSE, 2A 600V CLASS CC		2
12	052721	FUSE, 3.5A 600V CLASS CC DELAY		2
13	053604	CONTACTOR, 65A 3P 24VDC D-A SERIES		1
14	052465	CONTACTOR, 32A 3P 24VDC COIL		1
15	053590	RELAY, 12VDC 2NO CONTROL		1
16	053591	POWER SUPPLY, 24VDC 60W DIN MOUNT		1

SECTION 6 UP-DOWN SYSTEM

6.1 Saw Head Lift

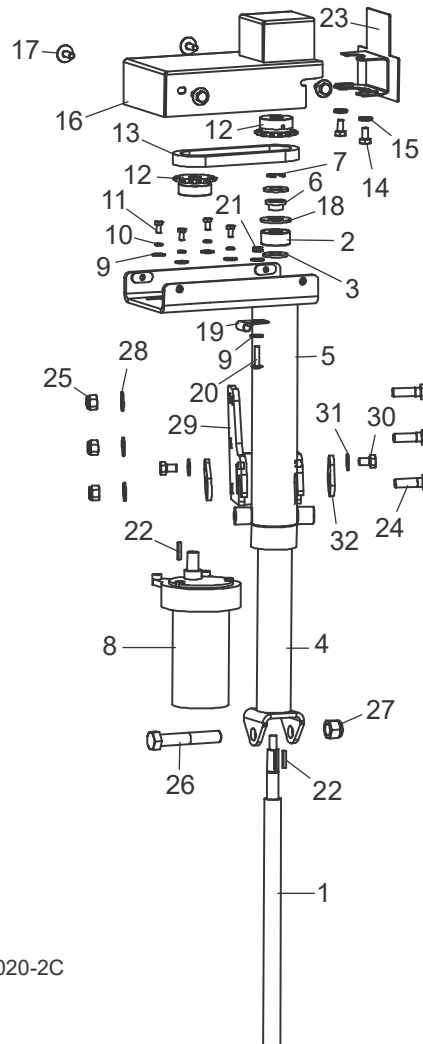

HR0020-2C

REF	PART #	DESCRIPTION	COMMENTS	QTY.
	074142	LIFT ASSEMBLY, HR120 SAW HEAD		1
1	025706	Shaft, HR Lift w/Setworks		1
2	063156	Bearing, 1/2" Thrust		1
3	F05011-2	Washer, 1/2" SAE Flat		2
4	063149	Tube Weldment, Saw Head Lift Base		1
5	074141	Tube Weldment, HR Lift		1
6	049007	Bushing, 1/2" ID x 5/8" OD x 3/8" Long Flanged		1
7	P10649	E-Clip, 1/2" Shaft		1
8	065767	Motor, 1/15HP 62RPM 12VDC 53:1 Gear		1
9	F05011-18	Washer, #10 SAE Flat		6
10	F05011-20	Washer, #10 Split Lock		4

REF	PART #	DESCRIPTION	COMMENTS	QTY.
11	F05004-60	Bolt, #10-32 x 1/2" Hex Head		4
12	101332-2	Sprocket, 35B14 x 1/2" Bore w/Set Screws		2
13	025751	Chain, #35 x 35 Pitches w/Master Link		1
14	F05005-15	Bolt, 1/4-20 x 1/2" Hex Head		2
15	F05011-14	Washer, 1/4" Split Lock		2
16	025755	Cover Weldment, HR130 Up/Down		1
17	F05005-134	Bolt, 1/4-20 x 3/4" Conical Washer Head		4
18	F05011-5	Washer, 5/8" SAE Flat		1
19	024155	Clamp, 1/4" Wire w/13/32" Mounting Hole		1
20	F05004-33	Screw, #10-24 x 7/8" Slotted Round Head		1
21	F05010-14	Nut, #10-24 Self-Locking Hex		1
22	036803	Key, 1/8" x 1/8" x 3/4"		2
23	065056	Cover, Encoder Mount		1
24	F05007-123	BOLT, 3/8-16 X 1 1/4" HEX HEAD		3
25	F05010-10	NUT, 3/8-16 HEX NYLON LOCK		3
26	F05008-23	BOLT, 1/2-13 X 3" HEX HEAD GRADE 5		1
27	F05010-8	NUT, 1/2-13 HEX NYLON LOCK		1
28	F05011-3	WASHER, 3/8" SAE FLAT		3
29	074137	LIFT WELDMENT, UPPER HR		1
30	F05006-15	BOLT, 5/16-18 X 1/2" HEX HEAD GRADE 5		2
31	F05011-17	WASHER, 5/16" SAE FLAT		2
32	074189	PLATE, LIFT RETAINER		2

6 Saw Head Components

Saw Head Mount & Blade Height Scale

6.2 Saw Head Mount & Blade Height Scale

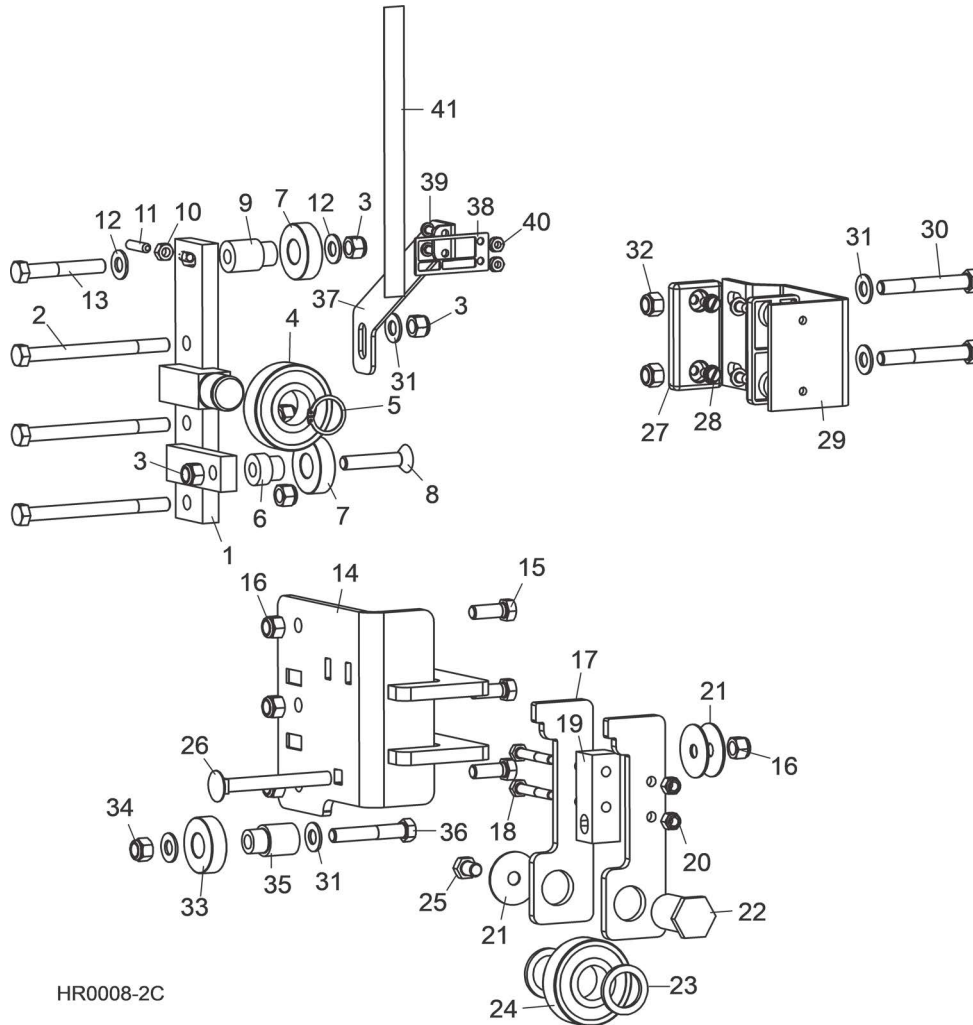

HR0008-2C

REF	PART #	DESCRIPTION	COMMENTS	QTY.
	046885	BEARING ASSEMBLY, SAW HEAD MOUNT UPPER		1
1	046635	Bracket Weldment, Upper Saw Head Mount		1
2	F05007-35	Bolt, 3/8-16 x 4 1/2" Hex Head		3
3	F05010-10	Nut, 3/8-16 Hex Nylon Lock		5
4	P08066	Bearing, .9843" x 2.4409" x .6693"		1
5	F04254-26	Ring, 25mm 5100-98 OR		1
6	046608	Bushing, Saw Head Mount Bearing		1
7	P06030-2	Bearing, 6203-2NSL 17mm SRI-2 ABEC-1		2
8	F05007-198	Bolt, 3/8-16 x 2" Flat Socket Head		1
9	074748	Spacer, Bearing		1
10	F05010-63	Nut, 1/4-20 Free		1

Saw Head Components

Saw Head Mount & Blade Height Scale

6

REF	PART #	DESCRIPTION	COMMENTS	QTY.
11	F05005-2	Screw, 1/4-20 x 1" SH Cup Pt Set		1
12	F05011-3	Washer, 3/8" SAE Flat		2
13	F05007-125	Bolt, 3/8-16 x 2 1/2" Hex Head Grade 5		1
	046886	BEARING ASSEMBLY, SAW HEAD MOUNT LOWER		1
14	046969	Bracket Weldment, Lower Saw Head Mount		1
15	F05007-97	Bolt, 3/8-16 x 1" Hex Head Grade 5		3
16	F05010-10	Nut, 3/8-16 Hex Nylon Lock		4
17	046604	Plate, Bearing Cam		2
18	046607	Block, Bearing Spacer		1
19	F05005-68	Bolt, 1/4-20 x 1 3/4" Hex Head Grade 5		2
20	F05010-69	Nut, 1/40-20 Hex Nylon Lock		2
21	F05011-44	Washer, 3/8" Fender		3
22	046606	Shaft, Bearing Mount		1
23	046974	Washer, Spacer		2
24	P08066	Bearing, .9843" x 2.4409" x .6693"		1
25	F05004-124	Bolt, 3/8-16 x 1/2" Hex Head Grade 5		1
26	F05007-161	Bolt, 3/8-16 x 3 1/2" Carriage Head		1
27	P13576	PAD, IDLE SIDE SLIDE		2
28	F05015-1	BOLT, 1/4-20 X 1/2" SLOTTED HEX HEAD		4
29	014905	BRACKET, IDLE SIDE SLIDE PAD MOUNT		1
30	F05007-29	BOLT, 3/8-16 X 2 3/4" HEX HEAD		2
31	F05011-3	WASHER, 3/8" SAE FLAT		4
32	F05010-10	NUT, 3/8-16 HEX NYLON LOCK		2
33	F05011-3	WASHER, 3/8" FLAT		1
34	F05010-10	NUT, 3/8-16 HEX NYLON LOCK		1
35	074748	SPACER, BEARING		1
36	F05007-201	BOLT, 3/8-16 X 2-1/4" HEX HEAD GRADE 5		1
37	046963	BRACKET, BLADE HEIGHT POINTER MOUNT	HR120	1
38	017805	POINTER, BLADE HEIGHT		1
39	F05004-3	SCREW, #10-24 X 3/8" PHILLIPS PAN HEAD		2
40	F05010-14	NUT, #10-24 SELF-LOCKING HEX		2
41	007653	DECAL, HR100 SERIES BLADE HEIGHT SCALE		1

SECTION 7 CONVEYOR BELT FEED SYSTEM

7.1 Feed Belt Conveyor

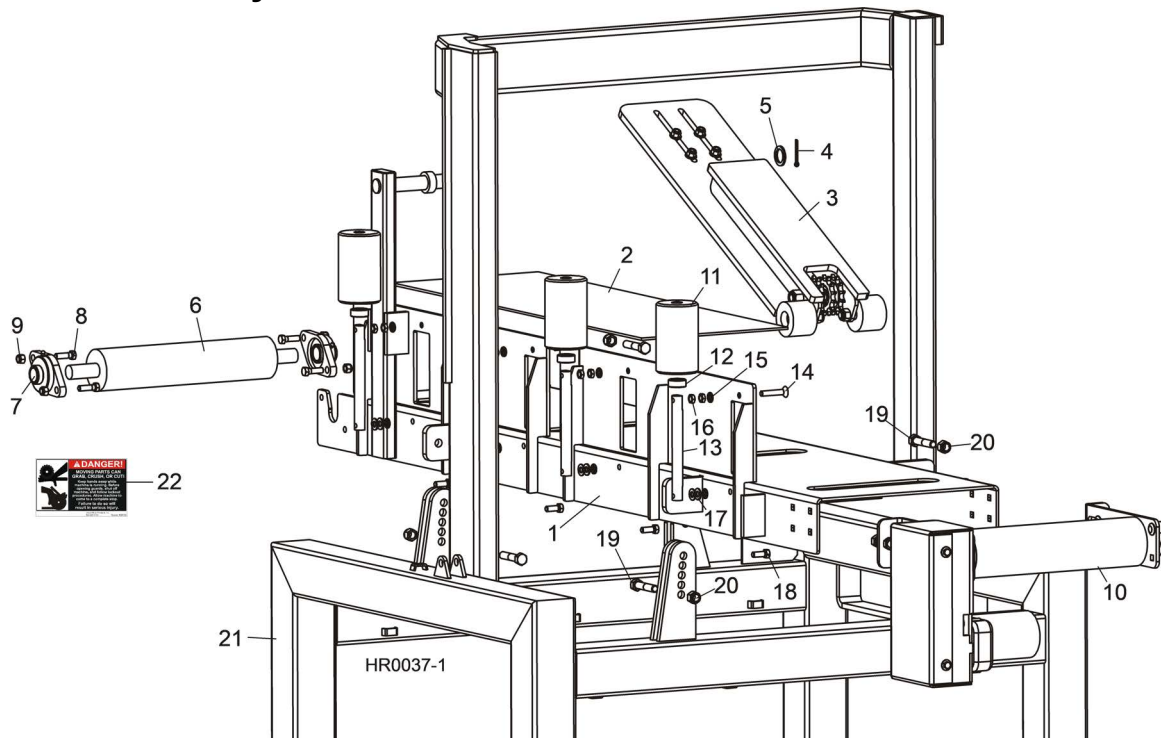

REF	PART #	DESCRIPTION	COMMENTS	QTY.
	063103	CONVEYOR ASSEMBLY, HR120 FEED BELT		1
1	063109	Frame Weldment, HR100 Series Conveyor		1
2	063175	Belt, 12" x 154" Rough Top Laced	(See Section 7.9) for optional shingle belt	1
	061189	Pin, Conveyor Belt .065	(See Section 7.5)	14
3		Hold-Down Parts		
4	F05012-23	Pin, 3/16" x 1 1/2" Cotter		1
5	046974	Washer, Spacer		1
6	063121	Pulley, 3" x 14" Crowned		1
7	038124	Bearing, 1" Flanged VF2S 216		2
8	F05007-123	Bolt, 3/8-16 x 1 1/4" Hex Head Grade 5		4
9	F05010-10	Nut, 3/8-16 Hex Nylon Lock		4
10		Belt Drive Parts	(See Section 7.4)	
	025770	Roller Assembly, HR100 Series Side		4
11	062447	Roller, Side		1
12	P04146	Collar, 3/4" ID Lock		1
13	062448	Shaft, Side Roller Mount		1
14	F05007-198	Screw, 3/8-16 x 2" Flat Socket Head		1
15	F05011-4	Washer, 3/8" Split Lock		2
16	F05010-29	Nut, 3/8-16 Hex Jam		2
17	F05011-3	Washer, 3/8" SAE Flat		2
18	F05007-82	Bolt, 3/8-16 x 1" Hex Head Grade 8		1
19	F05008-74	BOLT, 1/2-13 X 2 1/2 HEX HEAD GRADE 5		4
20	F05010-8	NUT, 1/2-13 HEX NYLON LOCK		4

REF	PART #	DESCRIPTION	COMMENTS	QTY.
21	063105	TABLE WELDMENT, HR100 SERIES RESAW		1
22	028720	DECAL, MOVING PARTS DANGER		2

7.2 Hold-Down Assembly

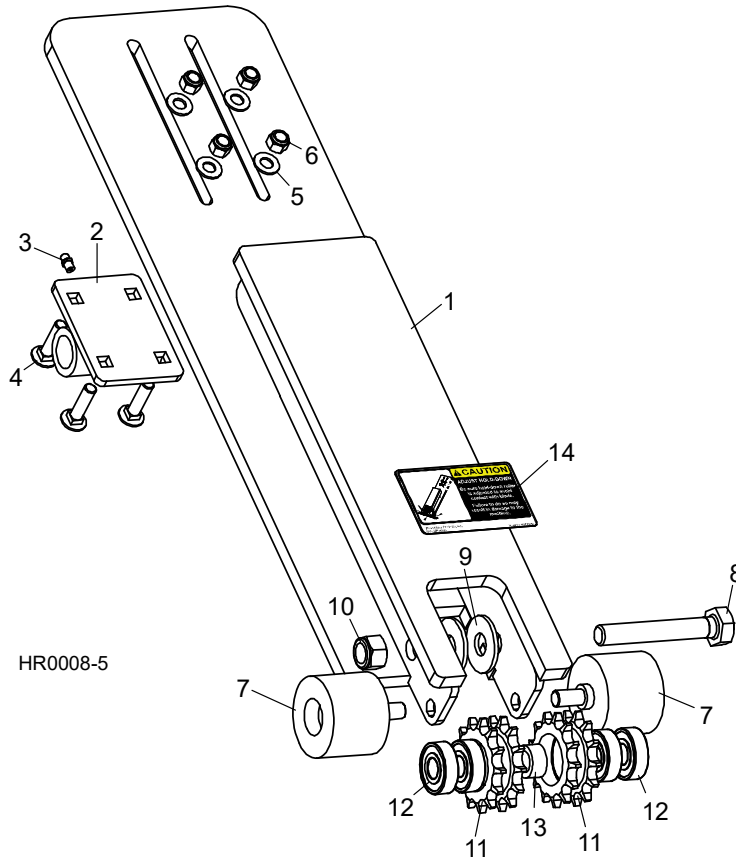

REF	PART #	DESCRIPTION	COMMENTS	QTY.
	063137	HOLD DOWN ASSY, CANT		1
1	063132	Box Weldment, Cant Hold-Down		1
2	063162	Pivot Weldment, Cant Hold-Down		1
3	P05060	Fitting, 1/4-28 Grease		1
4	F05007-85	Bolt, 3/8-16 x 1 1/2" Carriage Head Grade 5		4
5	F05011-3	Washer, 3/8" SAE Flat		4
6	F05010-10	Nut, 3/8-16 Hex Nylon Lock		4
7	063135	Roller, Cant Hold-Down		2
8	F05009-31	Bolt, 5/8-11 x 4 Hex Head Full Thread Grade 5		1
9	F05011-40	Washer, 5/8" Standard Flat		2
10	F05010-34	Nut, 5/8-11 Hex Nylon Lock		1
	016019	Sprocket Assy, #50-2 Idler		2
11	015202	Sprocket, D50B13 Modified		1
12	P06030-1	Bearing, 5/8" ID x 1.7548" OD x .4724"		2
13	063169	Spacer, 5/8" ID x 1" OD x .5"		1
14	063189	DECAL, ADJUST HOLD-DOWN CAUTION		1

7.3 Conveyor Feed Assembly

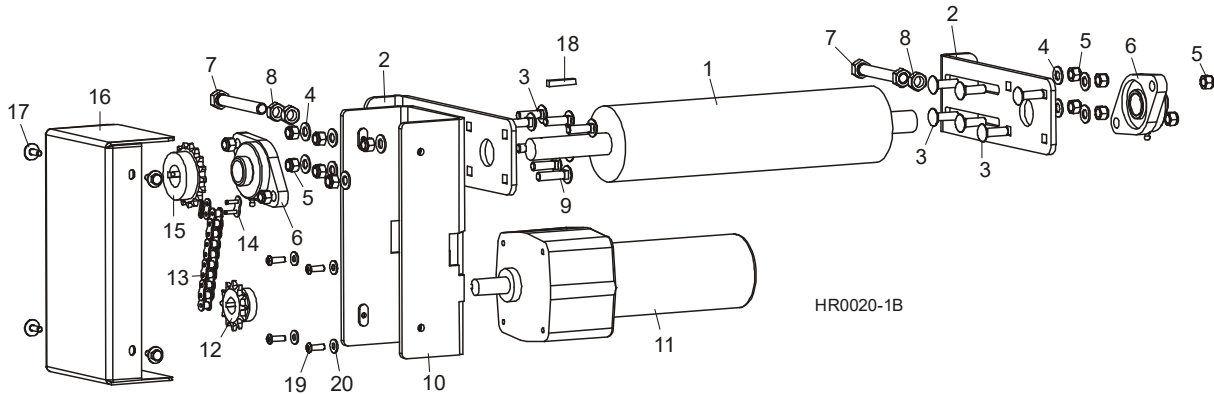

REF	PART #	DESCRIPTION	COMMENTS	QTY.
1	063122	PULLEY 3" X 14" LAGGED		1
2	063125	PLATE, ROLLER TENSION		2
3	F05007-127	BOLT, 3/8-16 X 1 1/4" CARRIAGE HEAD GRADE 5		12
4	F05011-3	WASHER, 3/8" SAE FLAT		10
5	F05010-10	NUT, 3/8-16 HEX NYLON LOCK		14
6	038124	BEARING, 1" FLANGED VF2S 216		2
7	F05008-111	BOLT, 1/2-20 X 3 3/4" HEX HEAD FULL THREAD GRADE 5		2
8	F05010-16	NUT, 1/2-20 HEX JAM		4
9	F05007-85	BOLT, 3/8-16 X 1 1/2" CARRIAGE HEAD GRADE 5		2
10	065734	MOUNT WELDMENT, FEED MOTOR		1
11	065735	MOTOR, 12V X 1/4HP GEAR 43:1 FEED		1
	061294	Brush Kit, Feed Motor HR120		1
12	101795	SPROCKET, 40B12 X 3/4" BORE		1
13	063184	CHAIN, #40 X 40 PITCH		1
14	P04200	LINK, #40 MASTER		1
15	003883	SPROCKET, 40B17 X 1" BORE		1
16	007606	COVER WELDMENT, FEED DRIVE		1
17	F05005-134	BOLT, 1/4-20 X 3/4" CONICAL WASHER HEAD		4
18	017832	KEY, 1/4" SQUARE X 1 3/8"		1
19	F05005-73	BOLT, 1/4-28 X 3/4" HEX HEAD GRADE 5		4
20	F05011-11	WASHER, 1/4" SAE FLAT		4

7 Conveyor Belt Feed System

Shingle Belt Assembly (Optional)

7.4 Shingle Belt Assembly (Optional)

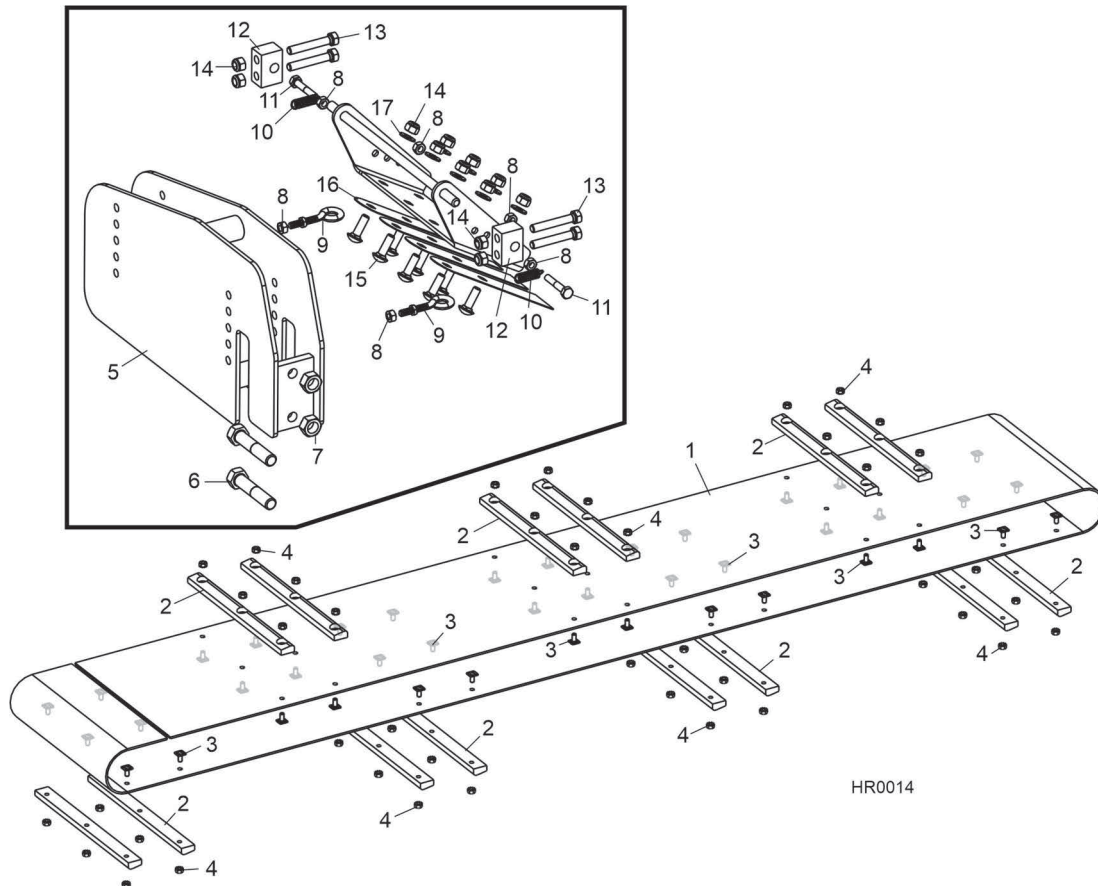

REF	PART #	DESCRIPTION	COMMENTS	QTY.
	HR120-SB	BELT ASSEMBLY, HR100 SERIES SHINGLE		1
1	063191	Belt, 12" Wide PVC		1
2	059366	Bar, Shingle Catch		14
3	007616	Stud, 1/4-20 x 1/2" Base Plate		42
4	F05010-9	Nut, 1/4-20 Self-Locking Hex		42
	059549	Hold-Down Assembly, HR100 Series Shingle		1
5	059547	Bracket Weldment, HR100 Series Shingle Stop		1
6	F05008-74	Bolt, 1/2-13 x 2 1/2" Hex Head Grade 5		2
7	F05010-35	Nut, 1/2-13 Hex		2
8	F05010-63	Nut, 1/4-20 Hex		6
9	007673	Bolt, 1/4-20 x 1 1/2" Eye w/Nut		2
10	046645	Spring, .375" OD x 1.25" Extension		2
11	F05005-5	Bolt, 1/4-20 x 1 1/2" Hex Head		2
12	059535	Block, Hold-Down Pivot		2

Conveyor Belt Feed System
Shingle Belt Assembly (Optional)

7

REF	PART #	DESCRIPTION	COMMENTS	QTY.
13	F05006-13	Bolt, 5/16-18 x 2" Hex Head Full Thread		4
14	F05010-59	Nut, 5/16-18 Hex Nylon Lock		12
15	F05006-9	Bolt, 5/16-18 x 1" Carriage Head Stainless		8
16	059552	Plate, Shingle Hold-Down Strap		4
17	F05011-17	Washer, 5/16" SAE Flat		8

SECTION 8 ENGINE ASSEMBLY

8.1 Engine (G19)

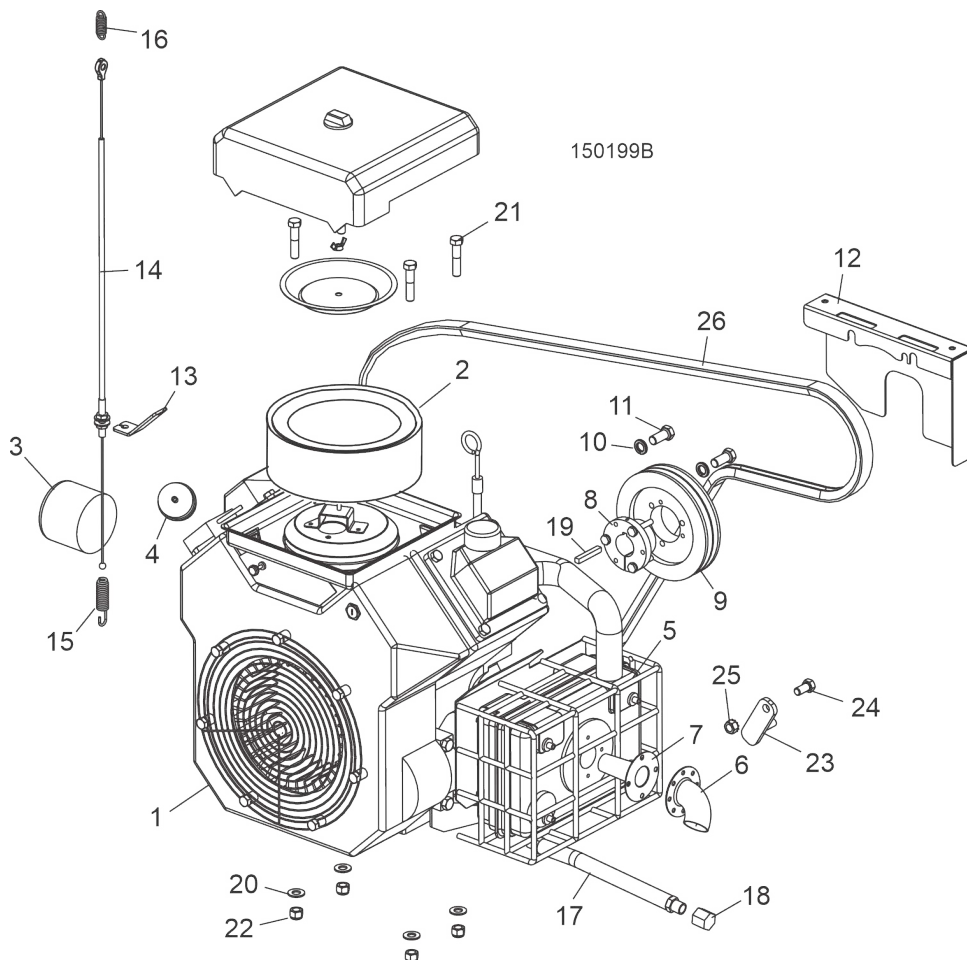

REF	PART #	DESCRIPTION	COMMENTS	QTY.
	143211	ENGINE ASSY, KOHLER G19 (CH620-3197)		1
1	133876	Engine, G19HP Kohler CH620-3197		1
	2	Filter, 19hp Kohler Air&PreClnr Kit		1
	P12757	Plug, RC12YC Kohler Spark #12-132-02		2
	061370	Module Kit, Kohler Ignition #KH24 584 45S (Qty. 2)		1
	048391	Pump, Kohler Fuel #24-393-16S		1
	061150	Switch, Kohler Ignition #25-099-37S		1
3	065264	Filter, Kohler Oil #12 050 01S		1
4	P12758	Filter, Kohler Fuel #24-050-13		1
5	065193	Muffler Assembly, Kohler		1

REF	PART #	DESCRIPTION	COMMENTS	QTY.
6	016495	Deflector, Kohler Muffler #12-755-28		1
7	016496	Arrestor, Kohler Spark #12-189-02		1
8	038432	Bushing, 1 1/8" SH		1
9	047742	Pulley, 3V5.6 x 2" SH		1
10	F05011-48	Washer, 7/16" Split Lock		2
11	F05007-145	Bolt, 7/16-14 x 1" Hex Head Grade 5		2
12	016493	Plate, Engine Guard		1
13	047750	Plate, Throttle Cable Mount		1
14	047749	Cable, LT15 G25 Throttle		1
15	016033	Spring, Throttle		1
16	015952	Spring, Throttle Extension		1
17	P10082	Hose, 3/8" NPT Oil Drain		1
18	P04332	Cap, Oil Drain Hose		1
19	S04124	Key, 1/4" x 1 11/16"		1
	024718	HARNES, BATTERY TO ENGINE		1
20	F05011-3	WASHER, 3/8" SAE FLAT		4
21	F05007-119	BOLT, 3/8-16 X 1 3/4" HEX HEAD GRADE 5		4
22	F05010-10	NUT, 3/8-16 HEX NYLON LOCK		4
23	048237	SUPPORT WELDMENT, DRIVE BELT		1
24	F05007-118	BOLT, 3/8-16 X 3/4" HEX HEAD GRADE 5		1
25	F05010-19	NUT, 3/8-16 SELF-LOCKING HEX		1
26	047751	BELT, 2/3VFL900 DRIVE (D17, D19 & G25 ONLY)		1

8 Engine Assembly

Engine (G25)

8.2 Engine (G25)

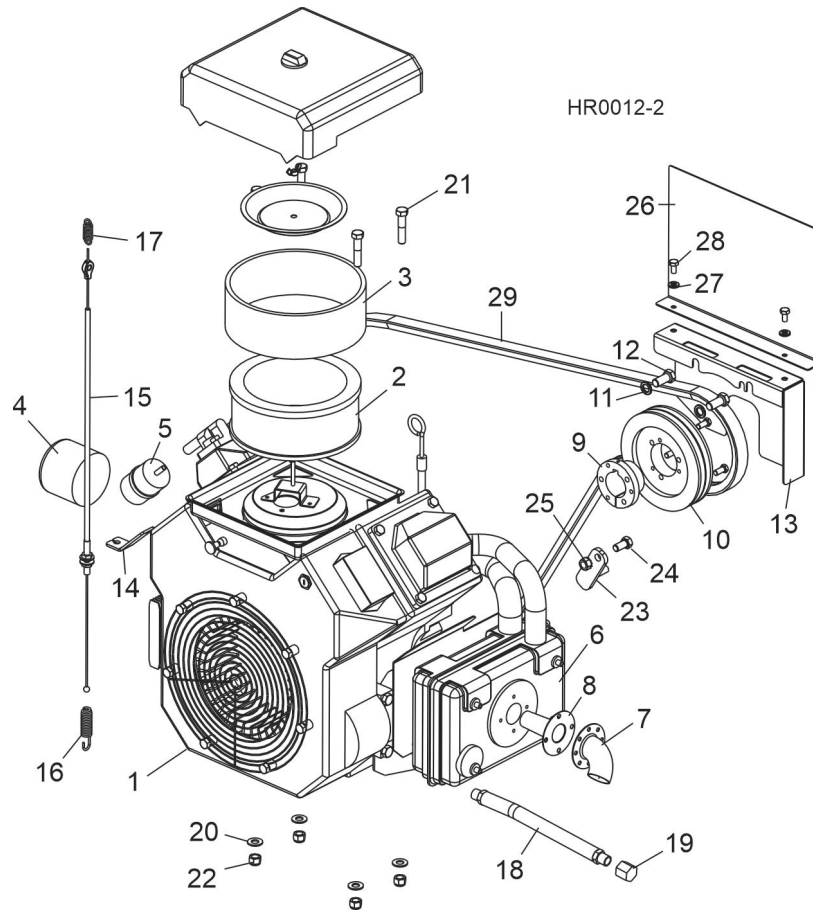

REF	PART #	DESCRIPTION	COMMENTS	QTY.
	015993	MANUAL, KOHLER CH25 OWNER'S		1
	015994	MANUAL, KOHLER CH25 SERVICE		1
	143105	ENGINE ASSY, KOHLER G25 (CH740-3384)		1
1	133873	Engine, G25HP Kohler CH740-3384 w/ Key		1
	016290	Gasket Kit, Kohler CH25 Head #24-757-31		1
	P12734	Filter Kit, Kohler Air/Pre #24-883-03-S1		1
2	P12736	Filter, Kohler Air #24-083-03	Available in assemblies only.	1
3	P12737	Pre Cleaner, Kohler #24-083-05	Available in assemblies only.	1
	P12757	Plug, RC12YC Kohler Spark #12-132-02		2
	016079	Module Kit, Kohler Ignition #25-584-14-S		2
4	014717	Filter, Kohler Oil #52-050-02		1
5	P12758	Filter, Kohler Fuel #24-050-13		1
	061150	Switch, Ignition G19/25		1
6	051569	Muffler Assembly, Kohler #24-786-19		1
7	016495	Deflector, Kohler Muffler #12-755-28		1

REF	PART #	DESCRIPTION	COMMENTS	QTY.
8	016496	Arrestor, Kohler Spark #12-189-02		1
9	016535	Bushing, 1 7/16" SH		1
10	047742	Pulley, 3V5.6 x 2" SH		1
11	F05011-48	Washer, 7/16" Split Lock		2
12	F05007-145	Bolt, 7/16-14 x 1" Hex Head Grade 5		2
13	016493	Plate, Engine Guard		1
14	047750	Plate, Throttle Cable Mount		1
15	047749	Cable, LT15 G25 Throttle		1
16	016033	Spring, Throttle		1
17	015952	Spring, Throttle Extension		1
18	P10082	Hose, 3/8" NPT Oil Drain		1
19	P04332	Cap, Oil Drain Hose		1
	061303	SOLENOID, FUEL SHUT OFF 24-757-01-S		1
	024718	HARNES, BATTERY TO ENGINE		1
20	F05011-3	WASHER, 3/8" SAE FLAT		4
21	F05007-119	BOLT, 3/8-16 X 1 3/4" HEX HEAD GRADE 5		4
22	F05010-10	NUT, 3/8-16 HEX NYLON LOCK		4
23	048237	SUPPORT WELDMENT, DRIVE BELT		1
24	F05007-118	BOLT, 3/8-16 X 3/4" HEX HEAD GRADE 5		1
25	F05010-19	NUT, 3/8-16 SELF-LOCKING HEX		1
26	063193	PLATE, AIR DEFLECTOR		1
27	F05011-14	WASHER, 1/4" SPLIT LOCK		2
28	F05005-15	BOLT, 1/4-20 X 1/2" HEX HEAD		2
29	047751	BELT, 2/3VFL900 DRIVE		1

8 Engine Assembly Engine (D17)

8.3 Engine (D17)

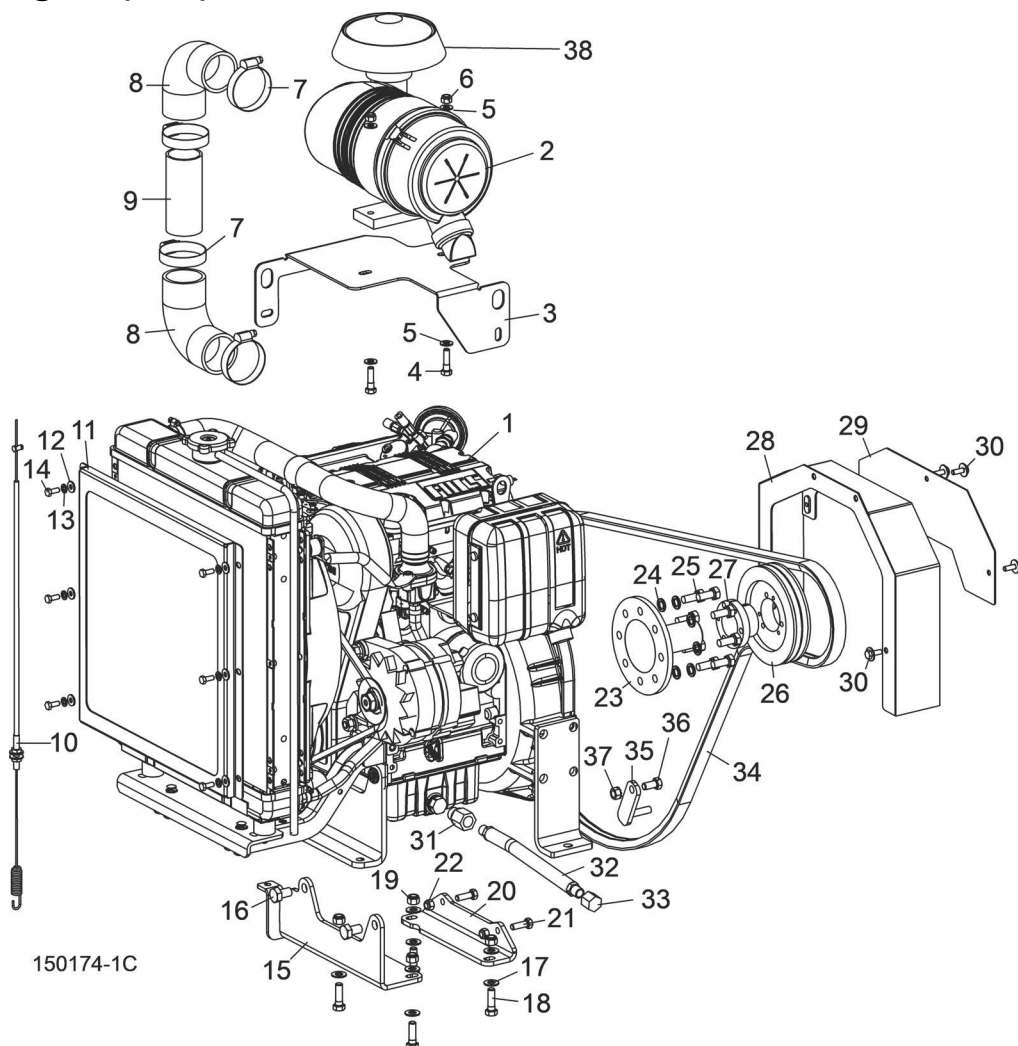

REF	PART #	DESCRIPTION	COMMENTS	QTY.
	007333	ENGINE ASSEMBLY, LT15 17HP DIESEL		1
1	007332	Engine, 17HP Kohler Diesel Model KDW702	Available in assemblies only.	1
2	007401	Filter Assembly, Kohler #ED0037004550-S		1
	007613	Filter, Kohler Secondary Air #ED0021751250-S		1
	007408	Filter, Kohler Primary Air #ED0021751240-S		1
	007614	Motor, Kohler Starter #ED0058402240-S		1
	065408	Alternator, Kohler 65A #ED0011572700-S		1
	065409	Belt, Kohler Fan #ED0024403160-S		1
	061187	Filter, Kohler/Lombardini Oil #ED0021752830-S		1

REF	PART #	DESCRIPTION	COMMENTS	QTY.
	061188	Filter, Kohler/Lombardini Fuel #ED0021752880-S		1
	014557	Switch Kit, Oil Pressure w/Gasket		1
	014279	Switch, Diesel Fuel Shut-Off		1
	014289	Pump, Diesel Fuel		1
	014278	Plug, Diesel Glow		2
3	062308	Bracket, Air Filter Mount		1
4	F05006-18	Bolt, 5/16-18 x 1 1/4" Hex Head Full Thread		2
5	F05011-17	Washer, 5/16" SAE Flat		4
6	F05010-20	Nut, 5/16-18 Self-Locking Hex		2
7	P09895	Clamp, 2 1/2" Hose		4
8	007394	Elbow, 90° x 2" ID Rubber		2
9	007395	Tube, 1 3/4" ID x 2" OD x 4"		1
10	007392	Cable, LT15 D17D17		1
11	007465	Guard Weldment, D17 Radiator		1
12	F05011-11	Washer, 1/4" SAE Flat		6
13	F05011-14	Washer, 1/4" Split Lock		6
14	F05004-219	Bolt, M6 x 1.0 x 16mm Hex Head		6
15	007427	Bracket Weldment, Rear D17 Mount		1
16	F05004-251	Bolt, M12 x 1.75 x 20mm Hex Head Full Thread		2
17	F05011-3	Washer, 3/8" SAE Flat		8
18	F05007-123	Bolt, 3/8-16 x 1 1/4" Hex Head Grade 5		4
19	F05010-10	Nut, 3/8-16 Hex Nylon Lock		4
20	007426	Bracket, D17 Front Mount		1
21	F05006-27	Bolt, 5/16-18 x 1" Hex Head Grade 5		2
22	F05010-58	Nut, 5/16-18 Hex Nylon Lock		2
23	014024	Shaft, Diesel Engine Drive		1
24	F05011-88	Washer, 10mm Split Lock		8
25	F81003-11	Bolt, M10-1.5 x 24mm Hex Head Grade 8.8		8
26	047742	Sheave, 3V5.6 x 2-SH		1
27	007338	Bushing, SH - 1 9/16"		1
28	007336	Guard Weldment, Motor Pulley		1
29	007344	Cover, Engine Pulley Guard		1
30	F05005-134	Bolt, 1/4-20 x 3/4" Hex w/Conical Washer Head		4
31	065163	Fitting, M18 x 3/8" NPT Adaptor		1
32	P10082	Hose, 3/8" NPT x 9 5/8" Rubber		1
33	P04332	Fitting, 3/8" Galvanized Pipe Cap		1
34	047751	BELT, 2/3VFL900 DRIVE		1
35	048237	SUPPORT WELDMENT, DRIVE BELT		1
36	F05007-118	BOLT, 3/8-16 X 3/4" HEX HEAD GRADE 5		1
37	F05010-19	NUT, 3/8-16 SELF-LOCKING HEX		1
	074947	PANEL, FRONT D17 YANMAR		1

8 Engine Assembly

Motor (E10)

8.4 Motor (E10)

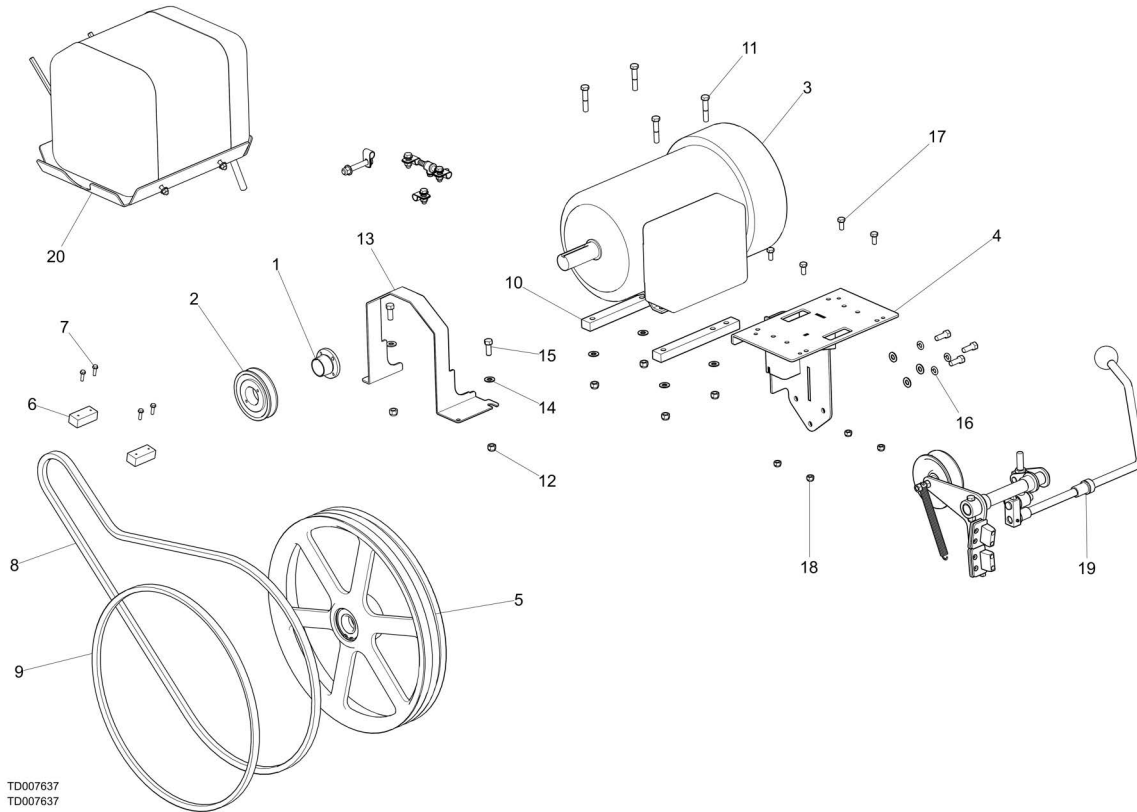

TD007637
TD007637

REF	PART #	DESCRIPTION	COMMENTS	QTY.
	007634	Motor Module, HR120 E10 1Ph		2
	036215.	Motor Assembly, LT15 10hp Single Phase		2
1	036214	Motor, 10hp Single Phase Lincoln 60Hz		2
2	p04864	Bushing, S/T H-1 3/8		2
3	036057	Sheave, BK45QT		2
4	034899	Mount Wldmt, Battery/Control Box		2
5	014995	Wheel Assembly, Lt15 Drive	See Section 2.1	2
6	016506	Block, Wood 3/4x1x2-3/16		4
7	f05015-33	Screw, #10x3/4 SI Hex Was Head Scr		8
8	p25301	Belt, BX85		2
9	p04185	BELT, B-57		2
10	034807	Spacer, Motor LT15E		4
11	f05007-124	Bolt, 3/8-16 x 2 HH Grd 8 YZD		8
12	f05010-10	Nut, 3/8-16 Hex Nyl Lock		12
13	034904	Guard, Motor Shaft LT15E10		2
14	f05011-3	Washer, 3/8 Flat SAE		18
15	f05007-7	Bolt, 3/8-16x1 HH		10
16	f05011-4	Washer, 3/8 Split Lock		6
17	f05006-102	Bolt, 5/16-18 x 3/4 HH Gr5		8

REF	PART #	DESCRIPTION	COMMENTS	QTY.
18	f05010-58.	Nut, 5/16-18 Nyl Lock		8
19		Throttle/Clutch Assembly (E15, E10)	See Section 8.14	1
20	015799	Tray Assembly, LT15 Water Bottle	See Section 4.2	1

8.5 Fuel Tank (G25)

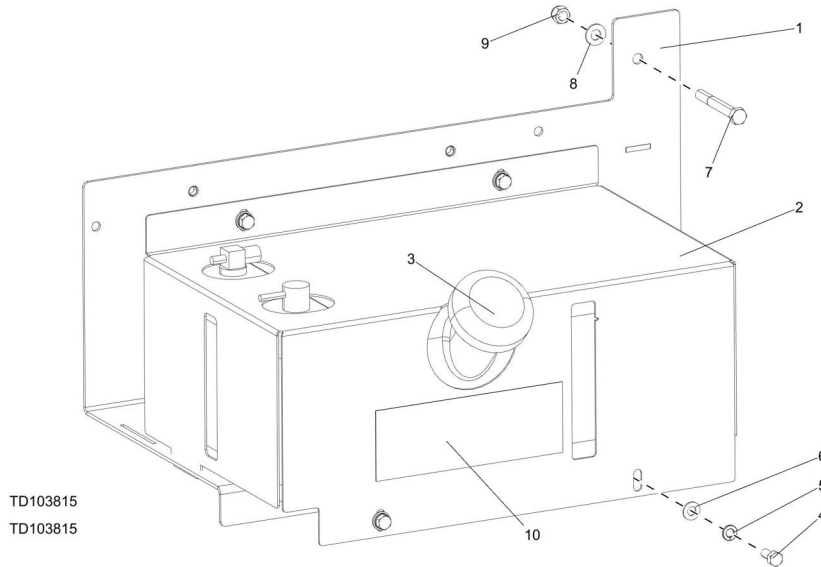

REF	PART #	DESCRIPTION	COMMENTS	QTY.
	103815	TRAY ASSEMBLY, LT15 FUEL TANK		1
1	103802	Weldment, Fuel Tank Tray		1
2	103867	Cover, Fuel Tank		1
3	103878	Tank, 5 Gallon Low Pro EPA Fuel	Fuel shut-off valve added to fuel tank to prevent possibility of fuel feeding back into engine during travel (HR120 Rev. A4.06). Created service part 074943 Fuel Pick-Up with Shut-Off Fitting.	1
4	F05006-102	Bolt, 5/16-18x3/4 HH Gr5 Zinc		4
5	F05011-13	Washer, 5/16 Split Lock		4
6	F05011-17	Washer, 5/16 SAE Flat		4
7	F05007-73	Bolt, 3/8-16 x 3" Hex Head Grade 5		2
8	F05011-3	Washer, 3/8" Flat SAE		2
9	F05010-10	Nut, 3/8-16 Hex Nyloc		2
10	133825	Decal, Fuel Warning		1
	R02423-1	Hose, Fuel 3/16" EPA 15G CARB		8 Ft.
	R02423-2	Hose, Fuel 1/4" EPA 15G CARB		8 Ft.

8.6 Fuel Tank (D17)

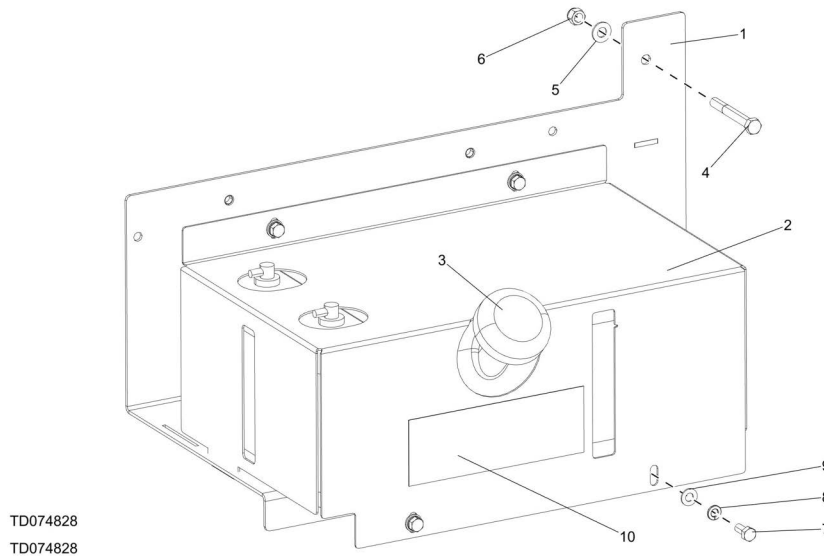

REF	PART #	DESCRIPTION	COMMENTS	QTY.
	074828	TANK ASSEMBLY, 5 GALLON DIESEL		1
1	103802	Weldment, Fuel Tank Tray		1
2	103867	Cover, Fuel Tank		1
3	103928	Tank, 5 Gallon Low Pro Diesel		1
	061257	Cap, Fuel Tank Diesel 080185BE		1
	061255	Fitting, Pick-Up/Tube Diesel 468871A		1
	061250	Grommet, Shut Off 046881		2
	061256	Fitting, Return/tube Diesel 468489		1
4	F05007-73	Bolt, 3/8-16 x 3" Hex Head Grade 5		2
5	F05011-3	Washer, 3/8" Flat SAE		2
6	F05010-10	Nut, 3/8-16 Hex Nyloc		2
7	F05006-102	Bolt, 5/16-18x3/4 HH Gr5 Zinc		4
8	F05011-13	Washer, 5/16 Split Lock		4
9	F05011-17	Washer, 5/16 SAE Flat		4
10	133825	Decal, Fuel Warning		1
	R02423-1	Hose, Fuel 3/16" EPA 15G CARB		8 Ft.
	R02423-2	Hose, Fuel 1/4" EPA 15G CARB		8 Ft.
	103802	Weldment, Fuel Tank Tray		1
	P649	Clamp, 7/32in-5/8in Hose		2
	P07584	Clamp, 1/2EMT Coated		1

8.7 Throttle/Clutch Assembly (G18/G25)

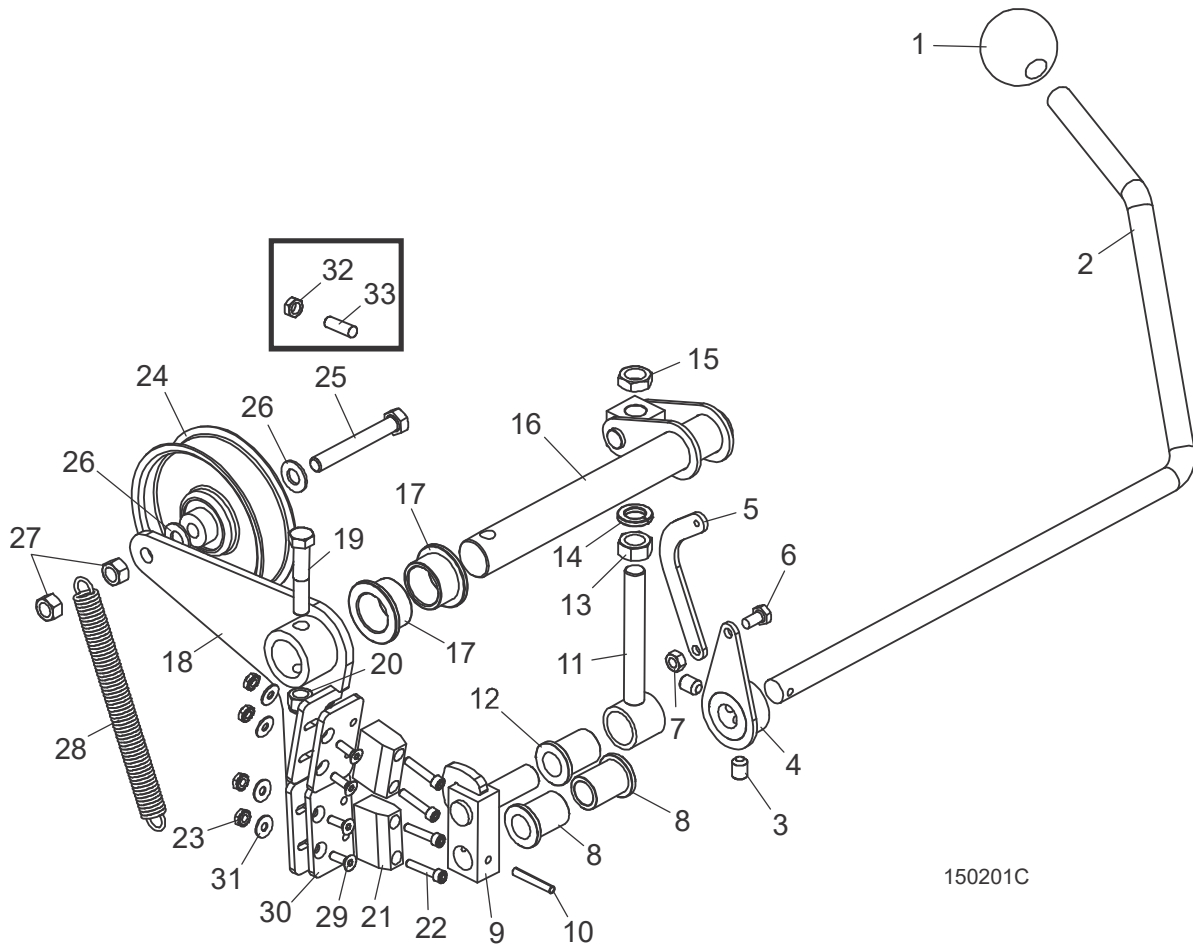

REF	PART #	DESCRIPTION	COMMENTS	QTY.
1	P04211	KNOB, 5/8-11 BALL		1
2	016487	HANDLE, LT15 CLUTCH		1
3	F05007-12	SCREW, 3/8-16 X 1/2 SOCKET HEAD CUP PT SET		2
4	034815	ACTUATOR WELDMENT, THROTTLE LT15D&G		1
5	034818	LINKAGE, THROTTLE LT15D&G		1
6	F05005-15	BOLT, 1/4-20 X 1/2" HEX HEAD		1
7	F05010-21	NUT, 1/4-20 SWAGED		1
8	016486	BUSHING, 5/8" ID X 7/8" OD X 1 1/8" LONG FLANGED BRONZE		2
9	065572	BLOCK WELDMENT, LINKAGE CLUTCH/BRAKE		1
10	F05012-16	PIN, 3/16 X 1 1/4 ROLL		1
11	034605	LINKAGE ASSEMBLY, W/BEARING		1

REF	PART #	DESCRIPTION	COMMENTS	QTY.
12	016486	Bushing, 5/8" ID x 7/8" OD x 1 1/8" Long Flanged Bronze		1
13	F05010-35	NUT, 1/2-13 FREE HEX, ZINC		1
14	F05011-9	WASHER, 1/2 SPLIT LOCK		1
15	F05010-31	NUT, 1/2-13 JAM		1
16	034608	PIVOT WELDMENT, CLUTCH/BRAKE		1
17	P737	BUSHING, 1 X 1 1/4 X 3/4 FLG BRONZE		2
	065874	BRAKE/CLUTCH ASSEMBLY, LT15		1
18	065873	Arm Weldment, Clutch/Brake LT15		1
19	F05007-124	Bolt, 3/8-16 x 2 Hex Head Gr5		1
20	F05010-10	Nut, 3/8-16 Hex Nylon Lock		2
21	016488	Block, LT15 Brake		2
22	F05004-2	Screw, 10-24 x 1" Socket Head		4
23	F05010-14	Nut, #10-24 Keps		4
24	034602	Idler, 4" O.D. x 3/8 Bore		1
25	F05007-125	Bolt, 3/8-16 x 2-1/2 Hex Head Gr5		1
26	F05011-3	Washer, 3/8 Flat		3
27	F05010-25	Nut, 3/8-16 Swaged Lock		1
28	034810	Spring, Idler Arm LT15/D/E/G		1
29	F05004-282	Screw, 10-24 x 5/8" FSHC		4
30	065872	Plate, Brake Adjustment		2
31	F05011-18	Washer, #10 SAE Flat		4

8 Engine Assembly

Throttle/Clutch Assembly (D17)

8.8 Throttle/Clutch Assembly (D17)

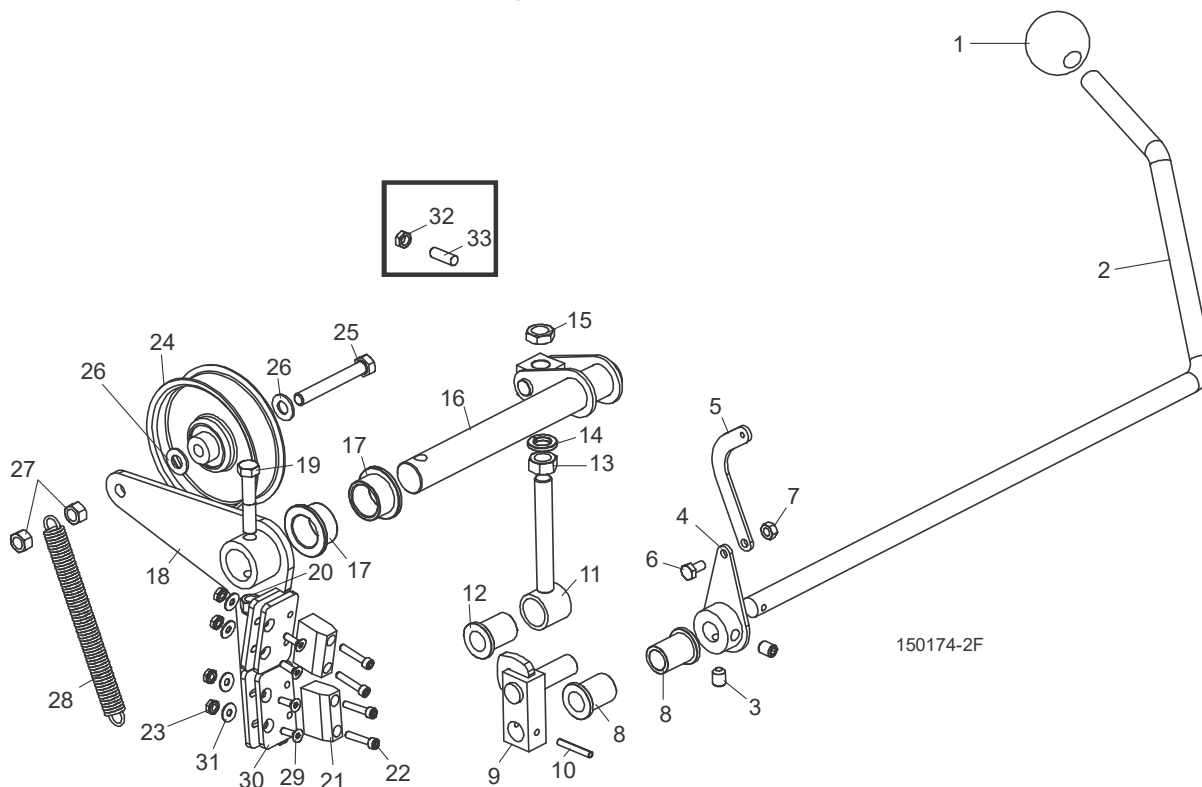

REF	PART #	DESCRIPTION	COMMENTS	QTY.
1	P04211	KNOB, 5/8-11 BALL		1
2	062313	HANDLE, LT15 CLUTCH		1
3	F05007-12	SCREW, 3/8-16 X 1/2" SOCKET HEAD CUP PT SET		2
4	034815	ACTUATOR WELDMENT, THROTTLE LT15D&G		1
5	034818	LINKAGE, THROTTLE LT15D&G		1
6	F05005-15	BOLT, 1/4-20 X 1/2" HEX HEAD		1
7	F05010-21	NUT, 1/4-20 SWAGED		1
8	016486	BUSHING, 5/8" ID X 7/8" OD X 1 1/8" LONG FL BRONZE		2
9	065572	BLOCK WELDMENT, LINKAGE CLUTCH/BRAKE		1
10	F05012-16	PIN, 3/16" X 1 1/4" ROLL		1
	034605	LINKAGE ASSEMBLY, W/BEARING		1
11	034604	Link Weldment, Clutch/Brake	Available in assemblies only.	1
12	016486	Bushing, 5/8" ID x 7/8" OD x 1 1/8" Long Fl Bronze		1
13	F05010-35	NUT, 1/2-13 FREE HEX, ZINC		1
14	F05011-9	WASHER, 1/2" SPLIT LOCK		1

REF	PART #	DESCRIPTION	COMMENTS	QTY.
15	F05010-31	NUT, 1/2-13 JAM		1
16	034608	PIVOT WELDMENT, CLUTCH/BRAKE		1
17	P737	BUSHING, 1" X 1 1/4" X 3/4" FLG BRONZE		2
	065874	BRAKE/CLUTCH ASSEMBLY, LT15		1
18	065873	Arm Weldment, Clutch/Brake LT15		1
19	F05007-124	Bolt, 3/8-16 x 2" Hex Head Gr5		1
20	F05010-10	Nut, 3/8-16 Hex Nylon Lock		2
21	016488	Block, LT15 Brake		2
22	F05004-2	Screw, 10-24 x 1" Socket Head		4
23	F05010-14	Nut, #10-24 Keps		4
24	034602	Idler, 4" O.D. x 3/8" Bore		1
25	F05007-230	Bolt, 3/8-16 x 2-3/4" Hex Head Gr5 Full Thread		1
26	F05011-3	Washer, 3/8" Flat		3
27	F05010-25	Nut, 3/8-16 Swaged Lock		1
28	034810	Spring, Idler Arm LT15D/E/G		1
29	F05004-282	Screw, 10-24 x 5/8" FSHC		4
30	065872	Plate, Brake Adjustment		2
31	F05011-18	Washer, #10 SAE Flat		4

8.9 Throttle/Clutch Assembly (E10)

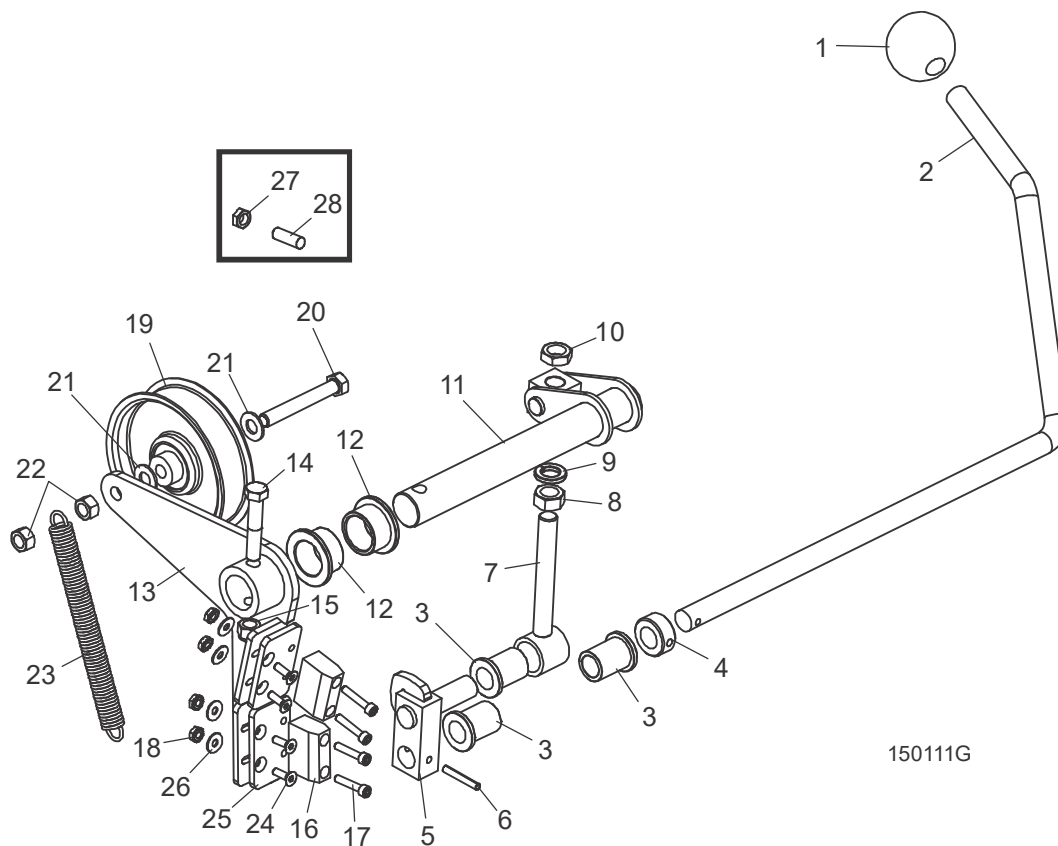

REF	PART #	DESCRIPTION	COMMENTS	QTY.
1	P04211	KNOB, 5/8-11 BALL		1
2	016487	HANDLE, LT15 CLUTCH		1
3	016486	BUSHING, 5/8 ID X 7/8 OD X 1 1/8 LONG FL BRONZE		2
4	P05035	COLLAR, 5/8 ID LOCK		1
5	065572	BLOCK WELDMENT, LINKAGE CLUTCH/BRAKE		1
6	F05012-16	PIN, 3/16 X 1 1/4 ROLL		1
7	034605	LINKAGE ASSEMBLY, W/BEARING		1
8	F05010-35	NUT, 1/2-13 FREE HEX, ZINC		1
9	F05011-9	WASHER, 1/2 SPLIT LOCK		1
10	F05010-31	NUT, 1/2-13 JAM		1
11	034608	PIVOT WELDMENT, CLUTCH/BRAKE		1
12	P737	BUSHING, 1 X 1 1/4 X 3/4 FLANGE BRONZE		2
	065874	BRAKE/CLUTCH ASSEMBLY, LT15		1
13	065873	Arm Weldment, Clutch/Brake LT15		1

REF	PART #	DESCRIPTION	COMMENTS	QTY.
14	F05007-124	Bolt, 3/8-16 x 2 Hex Head Gr5		1
15	F05010-10	Nut, 3/8-16 Hex Nylon Lock		2
16	016488	Block, LT15 Brake		2
17	F05004-2	Screw, 10-24 x 1 Socket Head		4
18	F05010-14	Nut, #10-24 Keps		4
19	034602	Idler, 4" O.D. x 3/8 Bore		1
20	F05007-125	Bolt, 3/8-16 x 2-1/2 Hex Head Gr5		1
21	F05011-3	Washer, 3/8 Flat		3
22	F05010-25	Nut, 3/8-16 Swaged Lock		1
23	034810	Spring, Idler Arm LT15/D/E/G		1
24	F05004-282	Screw, 10-24 x 5/8" FSHC		4
25	065872	Plate, Brake Adjustment		2
26	F05011-18	Washer, #10 SAE Flat		4

SECTION 9 TABLE OPTION

9.1 HR100 Series Tables

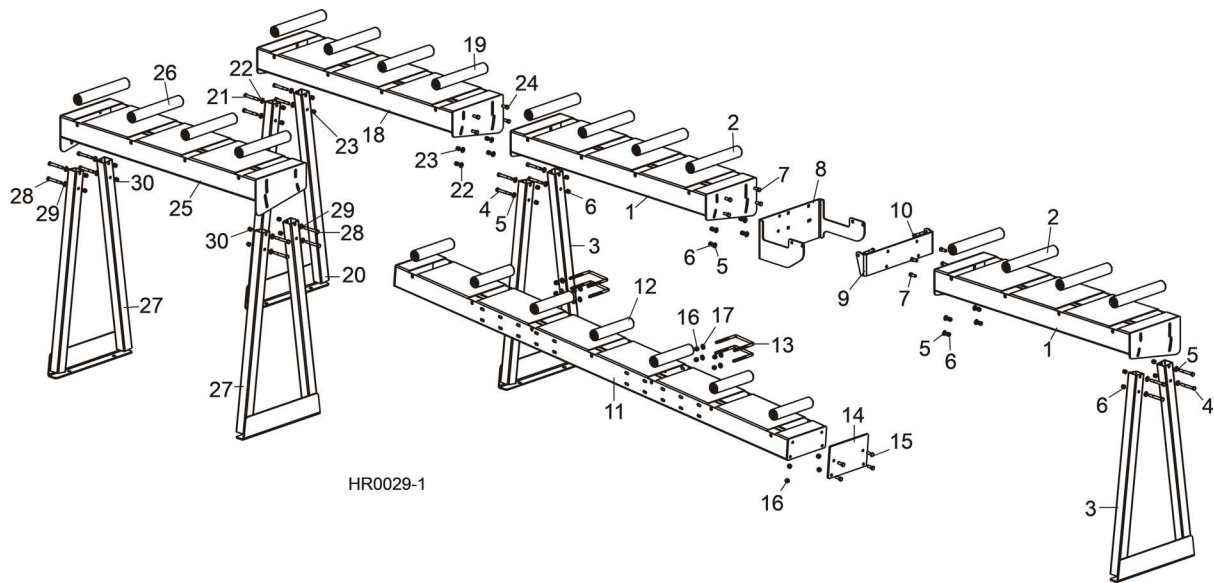

REF	PART #	DESCRIPTION	COMMENTS	QTY.
1-17	HRTBL-KIT	TABLE KIT, HR COMPLETE		1
1-7	HRTBL-END1	Table Kit, HR End		2
1	059561	Table Weldment, HR End		1
2	059563	Roller, 1.90" OD x 12"		4
3	059564	Leg Weldment, HR Table		1
4	F05007-73	Bolt, 3/8-16 x 3" Hex Head Grade 5		4
5	F05011-3	Washer, 3/8" SAE Flat		8
6	F05010-10	Nut, 3/8-16 Hex Nylon Lock		8
7	F05007-87	Bolt, 3/8-16 x 1" Hex Head Grade 5		4
8-10	HRTBL-MOUNT	Mount Kit, HR Table		1
8	059570	Plate, Table Mount Rear		1
9	059568	Plate, Table Mount		1
10	F05007-124	Bolt, 3/8-16 x 2" Hex Head Grade 5		2
11-17	HRTBL-SIDE	Table Kit, HR Side		1
11	059571	Table Weldment, HR Side		1
12	059584	Roller, 1.90" OD x 9"		7
13	003207	Bolt, 3/8-16 x 4" x 5" U		4
14	059574	Plate, Table Stop		1
15	F05007-87	Bolt, 3/8-16 x 1" Hex Head Grade 5		4
16	F05010-10	Nut, 3/8-16 Hex Nylon Lock		12
17	F05011-3	Washer, 3/8" Flat SAE		8
18-24	HRTBL-END1	TABLE KIT, HR 4' EXTENSION END		1
18	059561	Table Weldment, HR End		1
19	059563	Roller, 1.90" OD x 12"		4
20	059564	Leg Weldment, HR Table		1
21	F05007-73	Bolt, 3/8-16 x 3" Hex Head Grade 5		4

REF	PART #	DESCRIPTION	COMMENTS	QTY.
22	F05011-3	Washer, 3/8" SAE Flat		8
23	F05010-10	Nut, 3/8-16 Hex Nylon Lock		8
24	F05007-87	Bolt, 3/8-16 x 1" Hex Head Grade 5		4
25-30	HRTBL-END2	TABLE KIT, HR STAND-ALONE END		1
25	059561	Table Weldment, HR End		1
26	059563	Roller, 1.90" OD x 12"		4
27	059564	Leg Weldment, HR Table		2
28	F05007-73	Bolt, 3/8-16 x 3" Hex Head Grade 5		8
29	F05011-3	Washer, 3/8" SAE Flat		8
30	F05010-10	Nut, 3/8-16 Hex Nylon Lock		8