

Dear Wood-Mizer Owner:

Thank you for recognizing the importance of sawmill safety and placing the same high priority on safety as does Wood-Mizer.

As requested, we have enclosed a set of safety decals for your sawmill. Wood-Mizer encourages you to review each label as you place them on your sawmill. In addition, we have enclosed the updated Safety Section from the current manual for your model mill.

In closing, Wood-Mizer will continue to strive to offer the safest portable sawmills in the industry. Your safety is our main concern.

Sincerely,

A handwritten signature in blue ink that reads "Jim Brown". The signature is written in a cursive style with a large, looping initial "J".

Jim Brown
Vice President of Customer Service

SAFETY

Safety Symbols

The following symbols and signal words call your attention to instructions concerning your personal safety. Be sure to observe and follow these instructions.



DANGER! indicates an imminently hazardous situation which, if not avoided, will result in death or serious injury.



WARNING! suggests a potentially hazardous situation which, if not avoided, could result in death or serious injury.



CAUTION! refers to potentially hazardous situations which, if not avoided, may result in minor or moderate injury or damage to equipment.



IMPORTANT! indicates vital information.

NOTE: gives helpful information.



Warning stripes are placed on areas where a single decal would be insufficient. To avoid serious injury, keep out of the path of any equipment marked with warning stripes.

Safety Instructions

NOTE: ONLY safety instructions regarding personal injury are listed in this section. Caution statements regarding only equipment damage appear where applicable throughout the manual.

OBSERVE SAFETY INSTRUCTIONS



IMPORTANT! Read the entire Operator's Manual before operating the sawmill. Take notice of all safety warnings throughout this manual and those posted on the machine. Keep this manual with this machine at all times, regardless of ownership.

Also read any additional manufacturer's manuals and observe any applicable safety instructions including dangers, warnings, and cautions.

Only persons who have read and understood the entire operator's manual should operate the sawmill. The sawmill is not intended for use by or around children.

IMPORTANT! It is always the owner's responsibility to comply with all applicable federal, state and local laws, rules and regulations regarding the ownership, operation and towing of your Wood-Mizer sawmill. All Wood-Mizer mill owners are encouraged to become thoroughly familiar with these applicable laws and comply with them fully while using or towing the mill.



WEAR SAFETY CLOTHING



WARNING! Secure all loose clothing and jewelry before operating the sawmill. Failure to do so may result in serious injury or death.

WARNING! Always wear gloves and eye protection when handling bandsaw blades. Changing blades is safest when done by one person! Keep all other persons away from area when coiling, carrying or changing a blade. Failure to do so may result in serious injury.

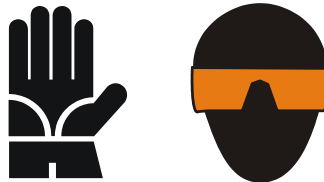

WARNING! Always wear eye, ear, respiration, and foot protection when operating or servicing the sawmill.



KEEP SAWMILL AND AREA AROUND SAWMILL CLEAN



DANGER! Maintain a clean and clear path for all necessary movement around the mill and lumber stacking areas. Failure to do so will result in serious injury.

HANDLE FUEL/LUBRICANTS SAFELY



DANGER! Due to the flammable nature of fuel and oil, never smoke, weld, grind or allow sparks near your engine or storage tanks, especially during times of fueling.

DANGER! Never allow fuel to spill on a hot engine during fueling operations or otherwise. The hot temperature of your engine could induce a fire or explosion.



WARNING! Store gasoline away from sawdust and other flammable materials. Failure to do so may result in serious injury.



WARNING! Use ONLY water with the water lube accessory. Never use flammable fuels or liquids. If these types of liquids are necessary to clean the blade, remove it and clean with a rag. Failure to do so may result in serious injury or death.

WARNING! Drum switch grease contains Petroleum Hydrocarbon Lubricant. Eye and skin irritant. If introduced into eyes, flush with water for at least 15 minutes. If film or irritation persists, seek medical attention. Wash skin with soap and water. If ingested, do not induce vomiting - contact a physician. **KEEP OUT OF THE REACH OF CHILDREN.**

DISPOSE OF SAWING BY-PRODUCTS PROPERLY



IMPORTANT! Always properly dispose of all sawing by-products, including sawdust and other debris, coolant, oil, fuel, oil filters and fuel filters.

USE CAUTION WHEN WORKING WITH BATTERIES



DANGER! Batteries expel explosive gases. Keep sparks, flames, burning cigarettes, or other ignition sources away at all times. Always wear safety goggles and a face shield when working near batteries. Failure to do so will cause serious injury.¹



WARNING! Battery posts, terminals and related accessories contain lead and lead compounds, chemicals known to the State of California to cause cancer and reproductive harm. Wash hands after handling.



WARNING! Charge the battery in a well ventilated area. Do not attempt to charge a frozen battery.

Use extreme care to avoid spilling or splashing electrolyte (which is dilute sulfuric acid) as it can destroy clothing and burn the skin. If electrolyte is spilled or splashed on clothing or the body, it should be neutralized immediately and then rinsed with clean water. A solution of baking soda, or household ammonia, and water may be used as a neutralizer.

Electrolyte splashed into the eyes is extremely dangerous. If this should happen, force the eye open and flood it with cool, clean water for approximately fifteen minutes. A doctor should be called immediately when the accident occurs and “on-the-spot” medical attention given if possible. If a doctor cannot come to the scene of the accident immediately, follow his instructions concerning actions to take. Do not add eye drops or other medication unless advised to do so by the doctor. Do not place a battery or acid within the reach of children. If acid (electrolyte) is taken internally drink large quantities of water or milk. Follow with milk of magnesia, beaten egg or vegetable oil. Call a physician immediately.

If electrolyte is spilled or splashed on any surface of the machine, it should be neutralized and rinsed with clean water.



CAUTION! Do not overcharge the battery. Overcharging may reduce the overall service life of the battery.

CAUTION! Be sure the battery is fully charged before transporting the sawmill. If the battery is not fully charged, excessive vibration could reduce the overall service life of the battery.

1. Battery Council International, copyright 1987

CAUTIONS FOR SAWMILL SETUP



WARNING! Do not set up the mill on ground with more than a 10 degree incline. If setup on an incline is necessary, put blocks under one side of the mill or dig out areas for the outrigger legs to keep mill level. Setting up the mill on an incline could cause it to tip over, resulting in serious personal injury.

WARNING! Chock the trailer wheels to prevent movement before unhitching it from the towing vehicle. Failure to do so may result in serious injury or death.

WARNING! Put front outrigger down before moving saw head from the rest position. Failure to do so may result in serious injury.

WARNING! Always make sure the trailer is supporting the sawmill frame when operating a sawmill with adjustable outriggers. Failure to do so may result in serious injury or death. The adjustable outriggers are intended to support the saw frame with assistance from the trailer.

WARNING! The adjustable outriggers supplied with portable sawmills are not intended for setup on concrete or other hard surfaces. Long-term use of the adjustable outriggers on hard surfaces may cause the outriggers to fail, causing the sawmill to drop. This could result in possible serious injury or death.

If setting the sawmill up on concrete or other hard surface, replace the adjustable outrigger legs with stationary legs.

WARNING! Securely fasten the feet of a stationary sawmill to the floor before operating the sawmill. Failure to do so may result in serious injury or death.

WARNING! The optional hydraulic log loader is operational whenever the saw carriage and contact strip are engaged, even with the keyswitch off. To avoid unintentional use of the loader, do not leave the sawmill unattended with the hydraulic power contacts engaged. Doing so may result in serious injury or death.

CHECK SAWMILL BEFORE OPERATION

 **DANGER!** Make sure all guards and covers are in place and secured before operating or towing the sawmill. Failure to do so may result in serious injury.

Be sure the blade housing and pulley covers are in place and secure. Use the safety retainer pin and cable to fasten blade housing covers.



1 Safety

Safety Instructions

KEEP PERSONS AWAY

 **DANGER!** Stay clear of the area between the trailer axle and saw carriage. Failure to do so will result in serious injury.



DANGER! Keep all persons out of the path of moving equipment and logs when operating sawmill or loading and turning logs. Failure to do so will result in serious injury.

DANGER! Always be sure the blade is disengaged and all persons are out of the path of the blade before starting the engine or motor. Failure to do so will result in serious injury.

KEEP HANDS AWAY



DANGER! Always disengage the blade and shut off the sawmill engine before changing the blade. Failure to do so will result in serious injury.

DANGER! Engine components can become very hot during operation. Avoid contact with any part of a hot engine. The exhaust components of your engine are especially hot during and following operation. Contact with hot engine components can cause serious burns. Therefore, never touch or perform service functions on a hot engine. Allow the engine to cool sufficiently before beginning any service function.

DANGER! Always keep hands away from moving bandsaw blade. Failure to do so will result in serious injury.

DANGER! Always be aware of and take proper protective measures against rotating shafts, pulleys, fans, etc. Always stay a safe distance from rotating members and make sure that loose clothing or long hair does not engage rotating members resulting in possible injury.



WARNING! Do not spin the blade wheels by hand. Spinning the blade wheels by hand may result in serious injury.

WARNING! Always disengage the clutch/brake mechanism whenever the sawmill is not cutting. Failure to do so may result in serious injury.

WARNING! Do not for any reason adjust the engine drive belts or belt support bracket with the engine running. Doing so may result in serious injury.

WARNING! Always keep clear of exiting sawdust. Keep hands, feet and any other objects away from the sawdust chute when operating sawmill. Failure to do so may result in serious injury.

CAUTIONS FOR GAS OR DIESEL ENGINE OPERATION



DANGER! Operate your engine/machine only in well ventilated areas. The exhaust gases of your engine can cause nausea, delirium and potentially death unless adequate ventilation is present.

DANGER! Never operate an engine with a fuel or oil leak. The leaking fuel or oil could potentially come in contact with hot surfaces and ignite into flames.

WARNING! Do not operate engine without proper and operational spark arrester/muffler. Sparks emitted from the engine exhaust could ignite surrounding materials, causing serious injury or death.

USE PROPER PROCEDURE WHEN CONDUCTING ELECTRICAL SAFETY CHECKS AND MAINTENANCE



DANGER! Make sure all electrical installation, service and/or maintenance work is performed by a qualified electrician and is in accordance with applicable electrical codes.

DANGER! Hazardous voltage inside the electric sawmill disconnect box, starter box, and at the motor can cause shock, burns, or death. Disconnect and lock out power supply before servicing! Keep all electrical component covers closed and securely fastened during mill operation.



WARNING! Consider all electrical circuits energized and dangerous.

WARNING! Disconnect the negative battery terminal cable before performing any service to the 12-Volt electrical system. Failure to do so may result in injury and/or electrical system damage.

WARNING! Never assume or take the word of another person that the power is off; check it out and lock it out.

WARNING! Do not wear rings, watches, or other jewelry while working around an open electrical circuit.

WARNING! Before performing service near moving parts such as blades, pulleys, motors, belts and chains, first turn the key switch to the OFF (#0) position and remove the key. If the key is turned on and moving parts activated, serious injury may result.

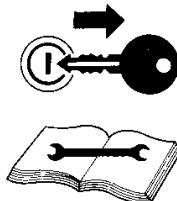

WARNING! Remove the blade before performing any service to the engine or sawmill. Failure to do so may result in serious injury.

DANGER! Lockout procedures must be used during:

- Changing or adjusting blades
- Unjamming operations
- Cleaning
- Mechanical repair
- Electrical maintenance
- Retrieval of tools/parts from work area
- Activities where guards or electrical panel guard is open or removed

Maintenance hazards include:

- Blade contact
- Pinch points
- Kickbacks
- Missiles (thrown blades/wood chips)
- Electrical

Failure to lockout may result in:

- Cut
- Crush
- Blindness
- Puncture
- Serious injury and death
- Amputation
- Burn
- Shock
- Electrocution

To control maintenance dangers:

Lockout procedures must be followed (see ANSI Standard Z244.1-1982 and OSHA regulation 1910.147).

Never rely on machine stop control for maintenance safety (emergency stops, on/off buttons, interlocks).

Do not reach into moving blades or feed systems. Allow all coasting parts to come to a complete stop.

Electrical power supply and air supply must both be locked out.

Where established lockout procedures cannot be used (electrical troubleshooting or mechanical dynamic troubleshooting), alternative effective protective techniques shall be employed which may require special skills and planning.

Always follow safe operations practices in the workplace.

SAWMILL LOCKOUT PROCEDURE

Lockout procedures must be followed (see ANSI Standard Z244.1-1982 and OSHA regulation 1910.147).

Purpose:

This procedure establishes the minimum requirements for lockout of energy sources that could cause injury.

Responsibility:

The responsibility for seeing that this procedure is followed is binding upon all workers. All workers shall be instructed in the safety significance of the lockout procedure. It is your responsibility to ensure safe operation of the machine.

Preparation For Lockout:

Sawmill must be locked out both electrically and pneumatically (lockout air valve).

Sequence of Lockout Procedure:

1. Notify all persons that a lockout is required and the reason therefore.
2. If the Sawmill is operating, shut it down by the normal stopping procedure.
3. Operate the switch and valve so that the energy sources are disconnected or isolated from the Sawmill. Stored energy such as moving blades, feed system and air pressure shall be dissipated.
4. Lockout the energy isolating devices with assigned individual locks.
5. After ensuring that no persons are exposed and as a check on having disconnected the energy sources, operate the push button or other normal operating controls to make certain the Sawmill will not operate. Caution: Return operating controls to neutral position after the test.
6. The Sawmill is now locked out.

Restoring Equipment to Service

1. When the job is complete and the Sawmill is ready for testing or normal service, check the Sawmill area to see that no one is exposed.
2. When the Sawmill is all clear, remove all locks. The energy isolating devices may be operated to restore energy to the Sawmill.

Procedure Involving More Than One Person

In the preceding steps, if more than one individual is required to lock out the Sawmill, each shall place his own personal lock on the energy isolating devices.

Rules for Using Lockout Procedure

The Sawmill shall be locked out to protect against accidental or inadvertent operation when such operation could cause injury to personnel. Do not attempt to operate any switch or valve bearing a lock.

Owner's Responsibility

The procedures listed in this manual may not include all ANSI, OSHA, or locally required safety procedures. It is the owner/operator's responsibility and not Wood-Mizer Products to ensure all operators are properly trained and informed of all safety protocols. Owner/Operators are responsible for following all safety procedures when operating and performing maintenance to the Sawmill.

KEEP SAFETY LABELS IN GOOD CONDITION



IMPORTANT! Always be sure that all safety decals are clean and readable. Replace all damaged safety decals to prevent personal injury or damage to the equipment. Contact your local distributor, or call your Customer Service Representative to order more decals.



IMPORTANT! If replacing a component which has a safety decal affixed to it, make sure the new component also has the safety decal affixed.

USE CAUTION WHEN WORKING WITH HEAVY LOGS



WARNING! Always make sure log is clamped securely before sawing. Failure to do so may result in serious injury or death.

WARNING! Always leave optional hydraulic loading arm halfway up while log is on sawmill bed. Failure to do so may result in serious injury or death.

OPTIONAL BOARD RETURN SAFETY



DANGER! Keep all persons out of the path of returning boards. Failure to do so will result in serious injury.



WARNING! The board return is intended to assist a second operator in removing boards quickly. Do not use the board return when operating the sawmill alone. Serious injury, death or damage to the equipment may result.

WARNING! Never use the board return table as a platform to stand on. This table is designed and intended to assist in the removal of boards only. Standing on the table may result in serious injury.

UP/DOWN SYSTEM SAFETY



WARNING! Always secure the saw head with a 5/16" chain with at least 1900 lbs. working load capacity before adjusting the up/down chain. The saw head may fall, causing severe injury or death.

WARNING! Always secure the saw head with a 5/16" chain with at least 1900 lbs. working load capacity before adjusting the mast pads. The saw head may fall, causing severe injury or death.

WARNING! Always secure the saw head with a 5/16" chain with approximately 1900 lbs. working load capacity before removing the up/down motor belt. The saw head may fall, causing severe injury or death.

POWER FEED SYSTEM SAFETY



DANGER! If leaving the blade engaged for maximum production rates, make sure the off-bearer stays out of the path of the blade. Failure to do so will result in serious injury or death.



WARNING! Be sure the power feed switch is in the neutral position before turning the key switch to the on (#1) or accessory (#3) position. This prevents accidental carriage movement which may cause serious injury or death.

GENERAL TRAILER SAFETY



DANGER! Make sure your hitch has adequate safety chain hook-ups. Do not use eyebolts for safety chain hook-up. Safety chains should be hooked to bumper of vehicle so that each chain would pull the trailer equally in the event the hitch became disengaged. Failure to do so may result in serious personal injury and/or severe machine damage.

DANGER! Be sure that the hitch and safety chains are secure before towing the sawmill. Failure to do so may result in serious personal injury and/or severe machine damage.

DANGER! Make sure all light connections have been made and are working properly before towing the sawmill. Failure to do so may result in serious personal injury and/or severe machine damage.



WARNING! Always check trailer tires for proper inflation before towing sawmill. Failure to do so may lead to tire failure resulting in property damage and/or serious injury or death.

ADDITIONAL SAFETY FOR ELECTRIC BRAKE TRAILERS



DANGER! Make sure the electric brake wire is secured as close to the trailer axle as possible to prevent wire disconnection during towing. Failure to do so may result in serious personal injury and/or severe machine damage.

DANGER! Be sure electric brake battery is charged and is working properly before towing the sawmill. Failure to do so may result in serious personal injury and/or severe machine damage.

DANGER! Do not use the electric brake system as an “emergency brake” while the sawmill is not being towed. Extended use of the electric brakes while the sawmill is stationary will drain the brake battery.

014419

WARNING

Burn Hazard
Avoid contact with any part of hot engine.
Failure to do so may result in serious injury.

WOODS CHISEL POINTERS, INC. Model No. 40324

Wood-Mizer®

Excavator/Mulchmaster
Model No. 40324
© 2002 Woods Chisel Pointers, Inc.
All rights reserved. Printed in the USA.

DANGER! READ THE OPERATOR'S MANUAL AND UNDERSTAND ALL SAFETY INSTRUCTIONS BEFORE YOU OPERATE THIS MACHINE.

LEER EL MANUAL DE OPERACIÓN Y CONVIÉRTASE EN TALLER. LEA TODAS LAS INSTRUCCIONES DE SEGURIDAD ANTES DE OPERAR LA MÁQUINA. LEA EL SECCIONADO DE LA MÁQUINA Y ENTENDE LAS INSTRUCCIONES DE SEGURIDAD ANTES DE OPERAR LA MÁQUINA. LEA TODAS LAS INSTRUCCIONES DE SEGURIDAD ANTES DE OPERAR LA MÁQUINA. LEA TODAS LAS INSTRUCCIONES DE SEGURIDAD ANTES DE OPERAR LA MÁQUINA.

SETUP PROCEDURE FOR SLOPING TERRAIN
OPERACION PARA OPERAR EN TERRENO INCLINADO.
PROCEDIMIENTO PARA OPERAR EN TERRENO INCLINADO.
CALCULAR EL PUNTO PARA PONER EL TERRENO AL NIVEL.

BLOCK UP DOWNHILL SIDE EXCAVATE UPHILL SIDE
PARA BLOQUEAR LA MÁQUINA EN UN TERRENO INCLINADO, BLOQUEAR EL LADO DE BAJO Y EXCAVAR EL LADO DE ARRIBA.
TRAMPOLINAR. BLOQUEAR EL LADO DE BAJO Y EXCAVAR EL LADO DE ARRIBA.

033254

DANGER

Moving Parts Can Crush And Cut
Make sure all guards and covers are in place before you are operating this machine.
Failure to do so will result in serious injury.

WOODS CHISEL POINTERS, INC. Model No. 40324

ADANGER

Moving bandsaw blades will cut.
Keep hands away.
Failure to do so will result in serious injury.

WOODS CHISEL POINTERS, INC. Model No. 40324

S11752

CAUTION

Do not try to force the saw.
If you force the saw, the motor and power travel links system may result.

WOODS CHISEL POINTERS, INC. Model No. 40324

S11762

WARNING

STOP!
Always wear eye, ear, respiration and foot protection when operating this machine.
Failure to do so may result in injury.

WOODS CHISEL POINTERS, INC. Model No. 40324

S11753

WARNING

Crush Hazard
Always put front outrigger down before moving the machine to the rest position.
Failure to do so may result in serious injury.

WOODS CHISEL POINTERS, INC. Model No. 40324

015400

016402

WARNING

STOP!
Read and understand operator's manual and all safety instructions just before operating or maintaining this machine.
Failure to do so may result in injury or equipment damage.

WOODS CHISEL POINTERS, INC. Model No. 40324

LOG RULE & LUMBER SCALE
ESCALA DE REGLAS DE MADERA
ESCALA DE REGLAS DE MADERA
ESCALA DE REGLAS DE MADERA

CONTENTS IN BOARD FEET
CONTENIDO EN TABLAS DE MADERA
CONTENIDO EN TABLAS DE MADERA

BOARD	THICKNESS	WIDTH	LENGTH	BOARD FEET
1x2	3/4"	1 1/2"	8'	16
1x4	3/4"	3 1/2"	8'	32
1x6	3/4"	5 1/2"	8'	48
1x8	3/4"	7 1/2"	8'	64
1x10	3/4"	9 1/2"	8'	80
1x12	3/4"	11 1/2"	8'	96
2x4	1 1/2"	3 1/2"	8'	32
2x6	1 1/2"	5 1/2"	8'	48
2x8	1 1/2"	7 1/2"	8'	64
2x10	1 1/2"	9 1/2"	8'	80
2x12	1 1/2"	11 1/2"	8'	96

P11754

WARNING

Dust And Projectile
Inspect projectile catches and clear them before turning each trigger of the sawmill.
Keep hands away from the sawmill.
Failure to do so may result in injury.

WOODS CHISEL POINTERS, INC. Model No. 40324

P10147

CAUTION

Release the blade tension when the mill is not in use to avoid damage to the blade tensioner and loss of fluid from the gauge.

WOODS CHISEL POINTERS, INC. Model No. 40324

300148-1

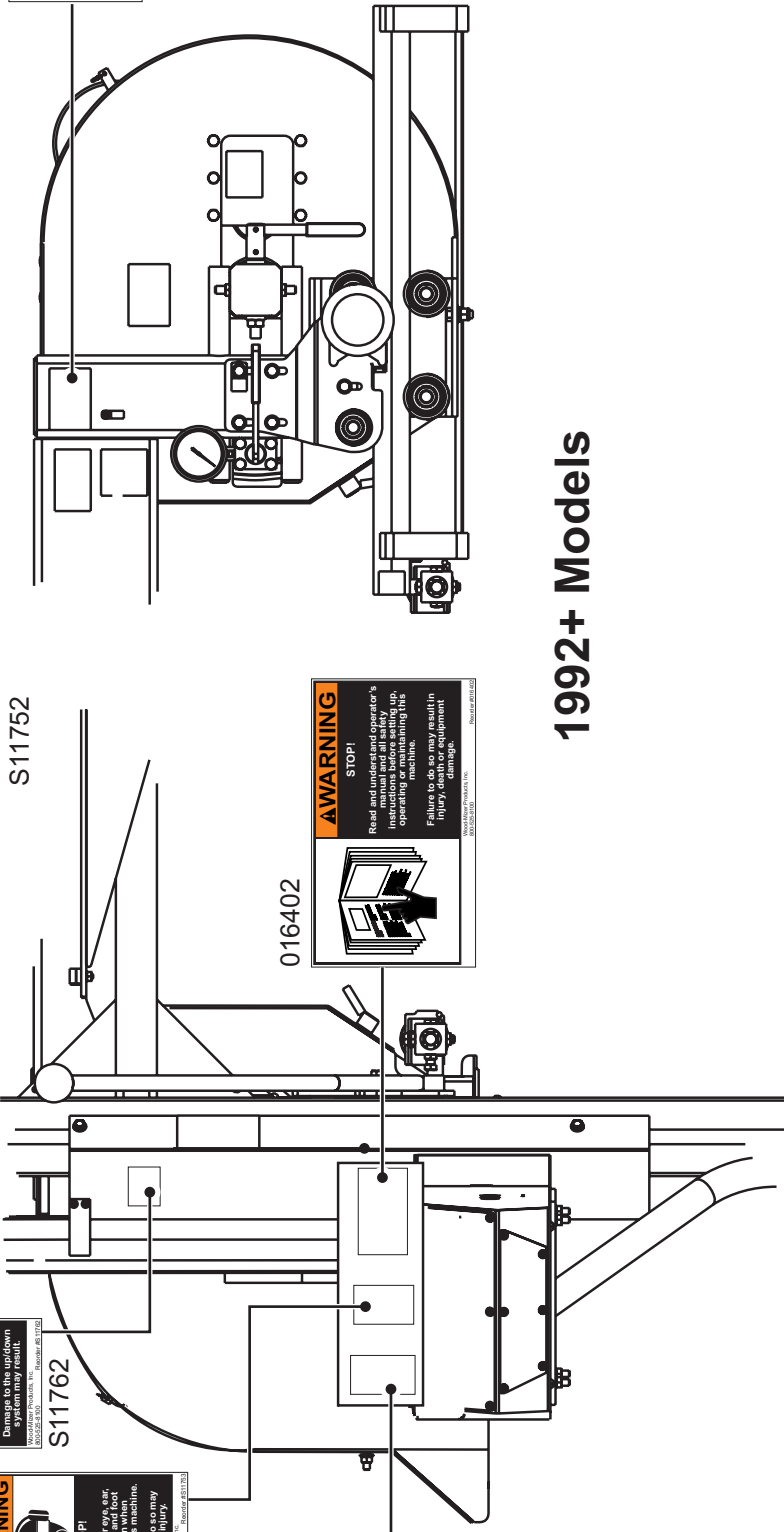

1992+ Models

014419

WARNING

Burn Hazard
Avoid contact with any part of hot engine. Failure to do so may result in serious injury.

WOOD-MIZER, INC. • P10147 • 014419

Wood-Mizer®

ANGER! READ THE OPERATOR'S MANUAL AND UNDERSTAND ALL SAFETY INSTRUCTIONS BEFORE YOU OPERATE THIS MACHINE.

LEER EL MANUAL DE OPERACION Y ENTENDE TODAS LAS INSTRUCCIONES DE SEGURIDAD ANTES DE OPERAR LA MACHINA. LEA Y ENTENDE TODAS LAS INSTRUCCIONES DE SEGURIDAD Y LAS INSTRUCCIONES DE OPERACION ANTES DE OPERAR LA MACHINA.

BEFORE OPERATING THIS MACHINE, READ AND UNDERSTAND ALL SAFETY INSTRUCTIONS AND OPERATING PROCEDURES. FAILURE TO DO SO MAY RESULT IN SERIOUS INJURY.

SET-UP PROCEDURE FOR SLOPING TERRAIN

OPERACION PARA ARRANCAR EN TERRENO CON PENDIENTE.
PROCEDIMIENTO PARA ARRANCAR EN TERRENO CON PENDIENTE.
CAUTION: BE SURE TO ALWAYS USE TERRAIN ADJUSTERS.

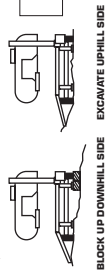

BLOCK UP DOWNHILL SIDE EXCAVATE UPHILL SIDE
FORWARD TILT ADJUSTER IS USED TO ADJUST THE MACHINES TILT TO THE SIDE OF THE HILLS.
TERRAIN ADJUSTERS ARE USED TO ADJUST THE MACHINES TILT TO THE SIDE OF THE HILLS.

LOG RULE & LUMBER SCALE

OPERACION DEL PRODUCTO
INSTRUCIONES DE SEGURIDAD Y PROCEDIMIENTOS DE OPERACION
CONTENIDOS EN ESTE LIBRO
CONTENIDOS EN ESTE LIBRO

CONTENTS IN BOARD FEET

CONTENIDOS EN TABLAS DE MADERA
CONTENIDOS EN TABLAS DE MADERA

LUMBER SCALE		METRIC SCALE	
INCHES	FEET	METERS	CUBIC METERS
1	0.083	0.025	0.0001
2	0.167	0.051	0.0002
3	0.250	0.076	0.0003
4	0.333	0.102	0.0004
5	0.417	0.127	0.0005
6	0.500	0.152	0.0006
7	0.583	0.178	0.0007
8	0.667	0.203	0.0008
9	0.750	0.229	0.0009
10	0.833	0.254	0.0010
11	0.917	0.279	0.0011
12	1.000	0.305	0.0012
13	1.083	0.330	0.0013
14	1.167	0.355	0.0014
15	1.250	0.381	0.0015
16	1.333	0.406	0.0016
17	1.417	0.431	0.0017
18	1.500	0.457	0.0018
19	1.583	0.482	0.0019
20	1.667	0.508	0.0020
21	1.750	0.533	0.0021
22	1.833	0.558	0.0022
23	1.917	0.584	0.0023
24	2.000	0.609	0.0024
25	2.083	0.635	0.0025
26	2.167	0.660	0.0026
27	2.250	0.685	0.0027
28	2.333	0.711	0.0028
29	2.417	0.736	0.0029
30	2.500	0.762	0.0030
31	2.583	0.787	0.0031
32	2.667	0.812	0.0032
33	2.750	0.838	0.0033
34	2.833	0.863	0.0034
35	2.917	0.889	0.0035
36	3.000	0.914	0.0036
37	3.083	0.939	0.0037
38	3.167	0.965	0.0038
39	3.250	0.990	0.0039
40	3.333	1.015	0.0040
41	3.417	1.041	0.0041
42	3.500	1.066	0.0042
43	3.583	1.091	0.0043
44	3.667	1.117	0.0044
45	3.750	1.142	0.0045
46	3.833	1.167	0.0046
47	3.917	1.193	0.0047
48	4.000	1.218	0.0048
49	4.083	1.243	0.0049
50	4.167	1.268	0.0050
51	4.250	1.294	0.0051
52	4.333	1.319	0.0052
53	4.417	1.344	0.0053
54	4.500	1.369	0.0054
55	4.583	1.395	0.0055
56	4.667	1.420	0.0056
57	4.750	1.445	0.0057
58	4.833	1.471	0.0058
59	4.917	1.496	0.0059
60	5.000	1.521	0.0060
61	5.083	1.546	0.0061
62	5.167	1.572	0.0062
63	5.250	1.597	0.0063
64	5.333	1.622	0.0064
65	5.417	1.647	0.0065
66	5.500	1.673	0.0066
67	5.583	1.698	0.0067
68	5.667	1.723	0.0068
69	5.750	1.748	0.0069
70	5.833	1.774	0.0070
71	5.917	1.799	0.0071
72	6.000	1.824	0.0072
73	6.083	1.849	0.0073
74	6.167	1.875	0.0074
75	6.250	1.900	0.0075
76	6.333	1.925	0.0076
77	6.417	1.950	0.0077
78	6.500	1.976	0.0078
79	6.583	2.001	0.0079
80	6.667	2.026	0.0080
81	6.750	2.051	0.0081
82	6.833	2.077	0.0082
83	6.917	2.102	0.0083
84	7.000	2.127	0.0084
85	7.083	2.152	0.0085
86	7.167	2.178	0.0086
87	7.250	2.203	0.0087
88	7.333	2.228	0.0088
89	7.417	2.253	0.0089
90	7.500	2.278	0.0090
91	7.583	2.304	0.0091
92	7.667	2.329	0.0092
93	7.750	2.354	0.0093
94	7.833	2.379	0.0094
95	7.917	2.405	0.0095
96	8.000	2.430	0.0096
97	8.083	2.455	0.0097
98	8.167	2.480	0.0098
99	8.250	2.506	0.0099
100	8.333	2.531	0.0100

033254

ADANGER

Moving Parts Can Crush And Cut.
Make sure all guards and covers are in place before operating this machine. Failure to do so will result in serious injury.

WOOD-MIZER, INC. • P10147 • 033254

ADANGER

Moving bandsaw blade will cut.
Keep hands away from the blade. Failure to do so will result in serious injury.

WOOD-MIZER, INC. • P10147 • 011752

S11752

CAUTION

Do not try to force the saw through the log. Excessive force and lower travel limits. Damage to the undown system may result.

WOOD-MIZER, INC. • P10147 • 011762

S11762

WARNING

STOP!
Always wear eye, ear, and respiratory protection when operating this machine. Failure to do so may result in injury.

WOOD-MIZER, INC. • P10147 • 011753

S11753

WARNING

Crush Hazard
Always pull front outrigger down before moving the machine. Failure to do so may result in serious injury.

WOOD-MIZER, INC. • P10147 • 015400

015400

016402

WARNING

STOP!
Read and understand operator's instructions before setting up, operating, or maintaining this machine. Failure to do so may result in injury, death or equipment damage.

WOOD-MIZER, INC. • P10147 • 016402

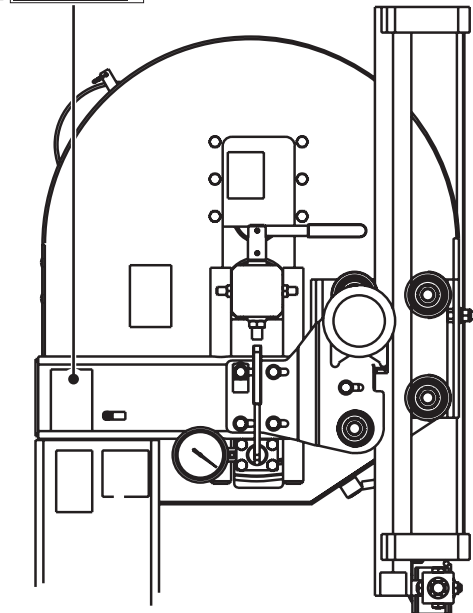

P10147
(Hydraulic Tensioner Only)

CAUTION
Changes in temperature can cause the blade tensioner to lose tension and lose of fluid from the gauge.
Release the blade tension when the mill is not in use to avoid damage to the blade tensioner.

WOOD-MIZER, INC. • P10147 • 015418

300148-2

1982-91 Models

S11761

CAUTION
To prevent tender damage, lower the saw head before operating sawmill or loading logs.

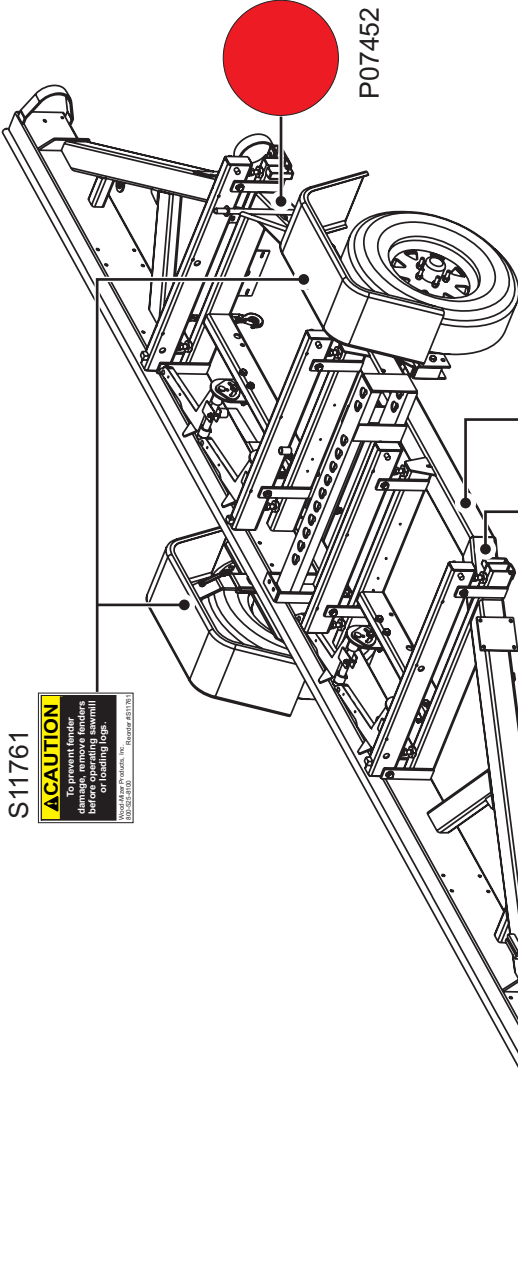

P07452

P07453

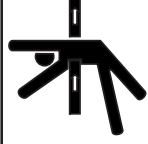

ADANGER
To Avoid Injury:
Keep all persons out of the path of moving equipment and logs when operating sawmill or loading or turning logs. Failure to do so will result in serious injury.

S09851

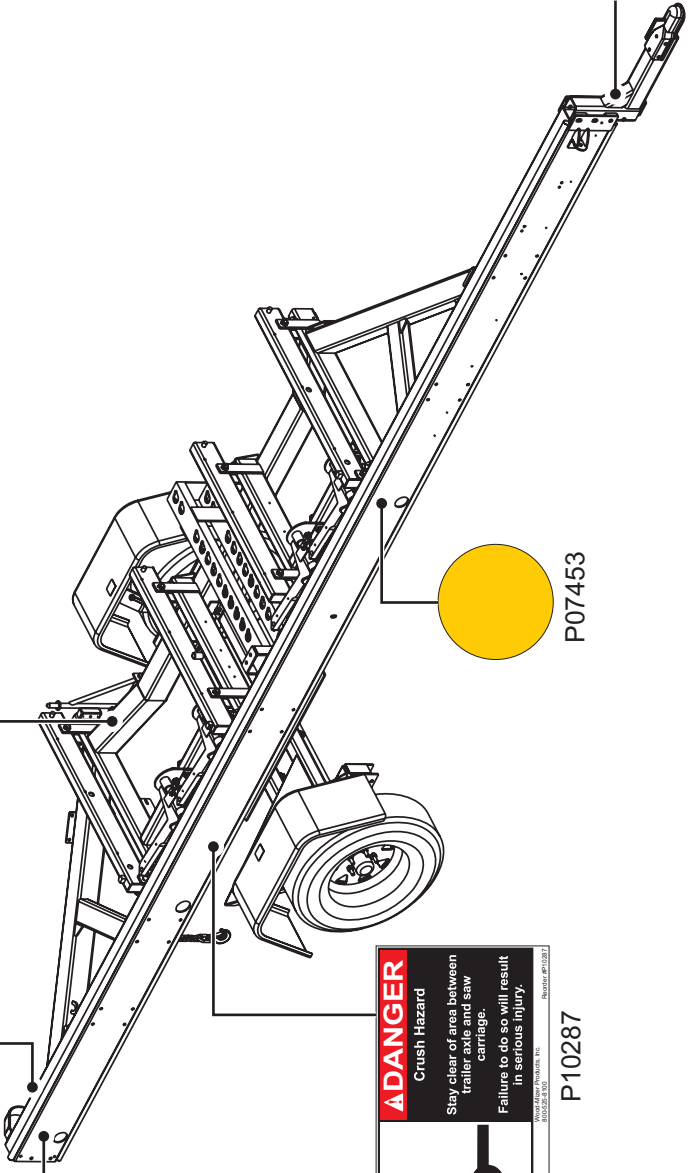

P07452

S12581

CAUTION
Lower the saw head onto the rear pin collar. Then, lower the saw head ensure that the saw head cannot be dislocated from the rear pin.
Failure to properly secure the saw head will result in severe machine damage.

ADANGER
Crush Hazard
Stay clear of area between trailer axle and saw carriage.
Failure to do so will result in serious injury.



P10287

014106

AWARNING
Towing Safety
Make sure all brake and light connections have working properly before towing the sawmill.
Be sure electric brake has working properly before towing the sawmill.
Failure to do so may result in serious injury.

300148-3

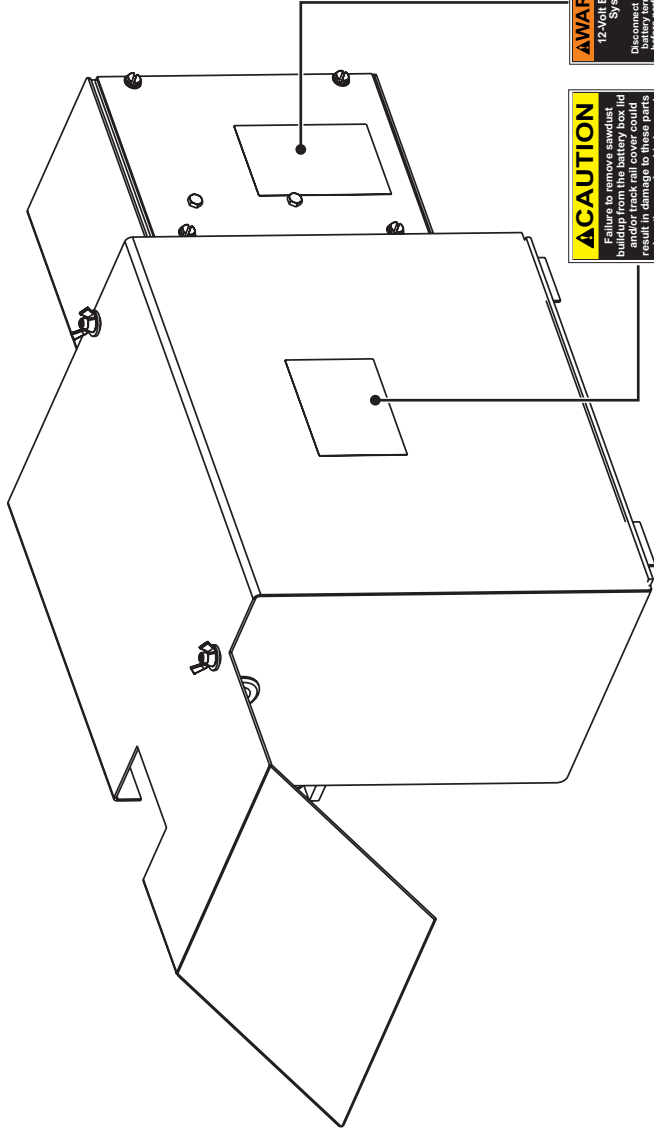

CAUTION
 Failure to remove sawdust lid
 before lowering track rail cover could
 result in damage to these parts
 when the saw head is lowered
 to its lowest position.

Part # 014774
 © 2010 Husqvarna, Inc.
 Husqvarna 014774

014774

WARNING
 12-Volt Electrical
 System
 Disconnect the negative
 battery terminal cable
 before working on the
 12-Volt electrical system.
 Failure to do so may
 result in injury and/or
 electrical system damage.
 See owner's manual for
 instructions.

© 2010 Husqvarna, Inc.
 Husqvarna 010364

P10364

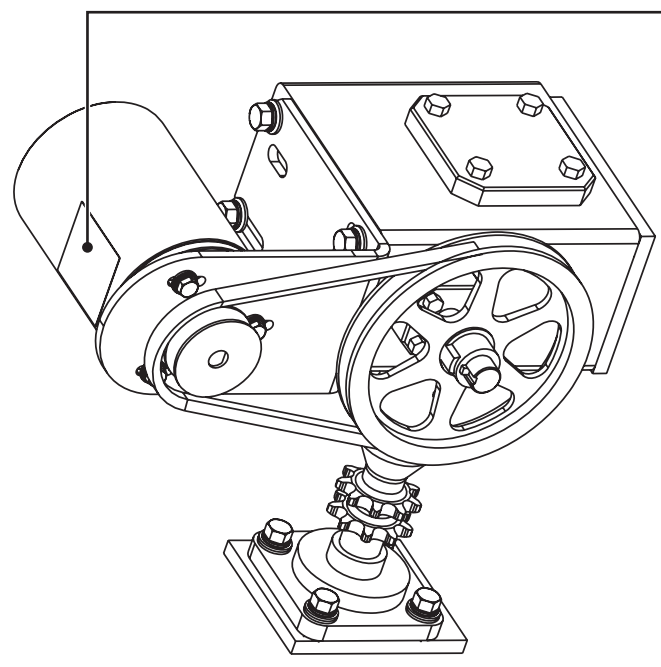

WARNING
 Disconnect motor leads
 before connecting any
 external power source. Failure to do so
 may cause serious injury
 or death. Disconnect the
 electrical system.

© 2010 Husqvarna, Inc.
 Husqvarna 024431

024431
 (Motors w/external
 power terminals
 only)

