

# **Twin Blade Edger**

## **Safety, Operation, Maintenance, & Parts Manual**

---

<b>EG200G26</b>	<b>rev. B2.03</b>
<b>EG200D24</b>	<b>rev. B2.03</b>
<b>EG200EC15</b>	<b>rev. B2.03</b>

---

***Safety is our #1 concern!***

*Form #904*



**WARNING! Read and understand this manual before using this machine.**

**California**  
Proposition 65 Warning



**WARNING:** Breathing gas/diesel engine exhaust exposes you to chemicals known to the State of California to cause cancer and birth defects or other reproductive harm.

- Always start and operate the engine in a well-ventilated area.
- If in an enclosed area, vent the exhaust to the outside.
- Do not modify or tamper with the exhaust system.
- Do not idle the engine except as necessary.

For more information go to **[www.P65warnings.ca.gov](http://www.P65warnings.ca.gov)**.



**WARNING:** Drilling, sawing, sanding or machining wood products can expose you to wood dust, a substance known to the State of California to cause cancer. Avoid inhaling wood dust or use a dust mask or other safeguards for personal protection.

For more information go to **[www.P65Warnings.ca.gov/wood](http://www.P65Warnings.ca.gov/wood)**.

**Active Patents assigned to Wood-Mizer, LLC**

Wood-Mizer, LLC has received patents that protect our inventions which are a result of a dedication to research, innovation, development, and design. Learn more at: [woodmizer.com/patents](http://woodmizer.com/patents)

**©March 25, 2022 Wood-Mizer LLC**

Printed in the United States of America, all rights reserved. No part of this manual may be reproduced in any form by any photographic, electronic, mechanical or other means or used in any information storage and retrieval system without written permission from

**Wood-Mizer, LLC**  
**8180 West 10th Street**  
**Indianapolis, Indiana 46214**

**ABOUT THIS MANUAL**

**SECTION 1 SAFETY**

2.1 Safety Symbols ..... 2-1  
2.2 Safety Instructions..... 2-2

**SECTION 2 SERVICE**

3.1 If You Need To Order Parts ..... 3-1  
3.2 Customer and Edger Identification ..... 3-1  
3.3 If You Need Service..... 3-2

**SECTION 3 SETUP AND OPERATION**

4.1 Setup..... 4-1  
4.2 Electrical Installation (EE15 Only)..... 4-1  
4.3 Pre-Operation Check..... 4-2  
4.4 Edging Lumber ..... 4-4  
4.5 Preparing the Edger for Towing..... 4-6

**SECTION 4 MAINTENANCE**

5.1 Changing the Blades ..... 5-1  
5.2 Tensioning the Belts..... 5-2  
5.3 Tensioning the Chains..... 5-3  
5.4 Checking the Rollers..... 5-4  
5.5 Lubrication ..... 5-4  
5.6 Maintaining and Sharpening Anti-Kickback Fingers ..... 5-4  
5.7 Alignment..... 5-4

**SECTION 5 TROUBLESHOOTING**

6.1 Boards Are Not Self-Feeding..... 6-1  
6.2 Jammed Boards ..... 6-1

## ABOUT THIS MANUAL

This manual is to replace or to be used with all previous information received on the Wood-Mizer®<sup>1</sup> EG200 Twin Blade Edger. All future mailings will be an addition to or a revision of individual sections of this manual as we obtain new information.

The information and instructions given in this manual do not amend or extend the limited warranties for the equipment given at the time of purchase.

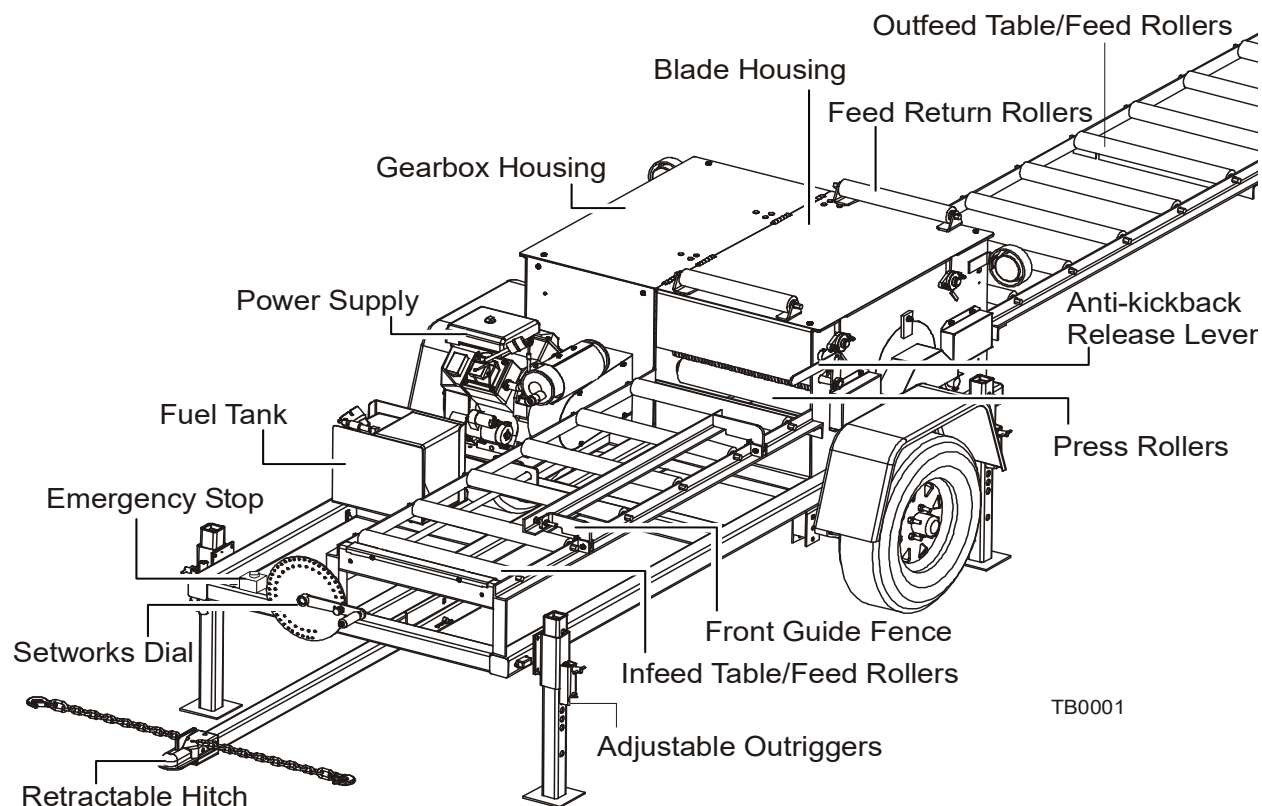

<sup>1</sup> Wood-Mizer® is a registered trademark of Wood-Mizer Products, Inc.

## SECTION 2 SAFETY

### 2.1 Safety Symbols

The following symbols and signal words call your attention to instructions concerning your personal safety. Be sure to observe and follow these instructions.



**DANGER!** indicates an imminently hazardous situation which, if not avoided, will result in death or serious injury.



**WARNING!** suggests a potentially hazardous situation which, if not avoided, could result in death or serious injury.



**CAUTION!** refers to potentially hazardous situations which, if not avoided, may result in minor or moderate injury or damage to equipment.



**IMPORTANT!** indicates vital information.

**NOTE:** gives helpful information.

## 2.2 Safety Instructions

**NOTE:** ONLY safety instructions regarding personal injury are listed in this section. Caution statements regarding only equipment damage appear where applicable throughout the manual.



**WARNING!** Clean sawdust from all guards, vents, control boxes, or any area where sawdust may gather after every shift. Failure to do so may result in fire, causing death or serious injury.



### OBSERVE SAFETY INSTRUCTIONS



**IMPORTANT!** Read the entire Owner's Manual before operating the Edger. Take notice of all safety warnings throughout this manual and those posted on the machine. Keep this manual with this machine at all times, regardless of ownership.

Also read any additional manufacturer's manuals and observe any applicable safety instructions including dangers, warnings, and cautions.

Only persons who have read and understood the entire operator's manual should operate the Edger. The Edger is not intended for use by or around children.

**IMPORTANT!** It is always the owner's responsibility to comply with all applicable federal, state and local laws, rules and regulations regarding the ownership, operation and towing of your Wood-Mizer Edger. All Wood-Mizer owners are encouraged to become thoroughly familiar with these applicable laws and comply with them fully while using or towing the Edger.



### WEAR SAFETY CLOTHING



**WARNING!** Secure all loose clothing and jewelry before operating the Edger. Failure to do so may result in serious injury or death.

**WARNING!** Always wear eye, ear, respiration, and foot protection when operating or servicing the Edger.



### DISPOSE OF SAWING BY-PRODUCTS PROPERLY

**WARNING!** Maintain a clean and clear path for all necessary movement around the Edger and lumber stacking areas. Failure to do so will result in serious injury.





**IMPORTANT!** Always properly dispose of all sawing by-products, including sawdust and other debris, coolant, oil, fuel, oil filters and fuel filters.

### USE CAUTION WHEN WORKING WITH BATTERIES



**DANGER!** Batteries expel explosive gases. Keep sparks, flames, burning cigarettes, or other ignition sources away at all times. Always wear safety goggles and a face shield when working near batteries. Failure to do so will cause serious injury.

 **WARNING!** Battery posts, terminals and related accessories contain lead and lead compounds, chemicals known to the State of California to cause cancer and reproductive harm. Wash hands after handling.

 **WARNING!** Charge the battery in a well ventilated area. Do not attempt to charge a frozen battery.

 **CAUTION!** Do not overcharge the battery. Overcharging may reduce the overall service life of the battery.

**CAUTION!** Be sure the battery is fully charged before transporting the edger. If the battery is not fully charged, excessive vibration could reduce the overall service life of the battery.

## HANDLE FUEL/LUBRICANTS SAFELY

 **DANGER!** Due to the flammable nature of fuel and oil, never smoke, weld, grind or allow sparks near your engine or storage tanks, especially during times of fueling.

**DANGER!** Never allow fuel to spill on a hot engine during fueling operations or otherwise. The hot temperature of your engine could induce a fire or explosion.

 **WARNING!** Store gasoline away from sawdust and other flammable materials. Failure to do so may result in serious injury.



## CHECK EDGER BEFORE OPERATION OR TOWING

 **DANGER!** Make sure all guards and covers are in place and secured before operating or towing the Edger. Failure to do so may result in serious injury.

 **WARNING!** Also make sure your hitch has adequate safety chain hookups. Safety chains should be hooked to bumper of vehicle so that each chain would pull the trailer equally in the event the hitch became disengaged. Failure to do so may result in serious personal injury and/or severe machine damage



**WARNING!** Always shut off the engine to stop the blade whenever the Edger is not in use. Failure to do so may result in serious injury.

**WARNING!** Do not for any reason adjust the engine drive belts with the engine running. Doing so may result in serious injury.

**WARNING!** Always ensure that there is a sharp point on the anti-kickback fingers before each use of the Edger.

Be sure anti-kickback fingers are free from obstruction and are in a downward position with lever released. Failure to do so may result in serious injury.

## KEEP PERSONS AWAY



**DANGER!** Keep all persons out of the path of moving equipment and boards when operating the Edger. Failure to do so will result in serious injury.

## KEEP HANDS AWAY



**DANGER!** Engine components can become very hot during operation. Avoid contact with any part of a hot engine. The exhaust components of your engine are especially hot during and following operation. Contact with hot engine components can cause serious burns. Therefore, never touch or perform service functions on a hot engine. Allow the engine to cool sufficiently before beginning any service function.

**DANGER!** Moving Parts Can Crush and Cut. Keep hands clear. Make sure all guards and covers are in place and secured before operating or towing. Failure to do so may result in serious injury.

**DANGER!** Always be aware of and take proper protective measures against rotating shafts, pulleys, fans, etc. Always stay a safe distance from rotating members and make sure that loose clothing or long hair does not engage rotating members resulting in possible injury.

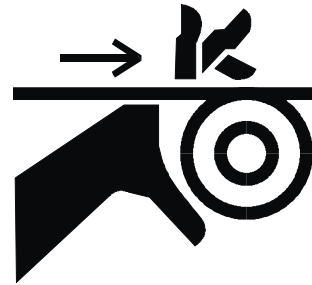





**WARNING!** Coastdown Required. Always shut off the engine and allow all moving parts to come to a complete stop before removing any guards or covers. Do NOT operate with any guards or covers removed.

**WARNING!** Kickback Hazard. Stay clear of area during operation. Follow all anti-kickback service and safety rules. Failure to do so may result in serious injury.



## CAUTIONS FOR ENGINE OPERATION



**DANGER!** Operate your engine/machine only in well ventilated areas. The exhaust gases of your engine can cause nausea, delirium and potentially death unless adequate ventilation is present.

**DANGER!** Never operate an engine with a fuel or oil leak. The leaking fuel or oil could potentially come in contact with hot surfaces and ignite into flames.

**WARNING!** Do not operate engine without proper and operational spark arrester/muffler. Sparks emitted from the engine exhaust could ignite surrounding materials, causing serious injury or death.

## USE PROPER PROCEDURE WHEN CONDUCTING ELECTRICAL SAFETY CHECKS AND MAINTENANCE



**DANGER!** Make sure all electrical installation, service and/or maintenance work is performed by a qualified electrician and is in accordance with applicable electrical codes.

**DANGER!** ARC FLASH AND SHOCK HAZARD! Hazardous voltage inside the electric sawmill disconnect box, starter box, and at the motor can cause shock, burns, or death. Disconnect and lock out power supply before servicing! Keep all electrical component covers closed and securely fastened during edger operation. Wear appropriate Personal Protection Equipment.



**WARNING!** Consider all electrical circuits energized and dangerous.

**WARNING!** Never assume or take the word of another person that the power is off; check it out and lock it out.

**WARNING!** Do not wear rings, watches, or other jewelry while working around an open electrical circuit.

**WARNING!** Before performing service near moving parts such as blades, pulleys, motors, belts and chains, first turn the engine key switch to the OFF (#0) position and remove the key. If the key is turned on and moving parts activated, serious injury may result.

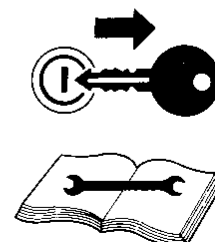

**DANGER!** Lockout procedures must be used during:

- Changing or adjusting blades
- Unjamming operations
- Cleaning
- Mechanical repair
- Electrical maintenance
- Retrieval of tools/parts from work area
- Activities where guards or electrical panel guard is open or removed

**Maintenance hazards include:**

- Blade contact
- Pinch points
- Kickbacks
- Missiles (thrown blades/wood chips)
- Electrical

Failure to lockout may result in:

- Cut
- Crush
- Blindness
- Puncture
- Serious injury and death
- Amputation
- Burn
- Shock
- Electrocution

**To control maintenance dangers:**

Lockout procedures must be followed (see ANSI Standard Z244.1-1982 and OSHA regulation 1910.147).

Never rely on machine stop control for maintenance safety (emergency stops, on/off buttons, interlocks).

Do not reach into moving blades or feed systems. Allow all coasting parts to come to a complete stop.

Electrical power supply and air supply must both be locked out.

Where established lockout procedures cannot be used (electrical troubleshooting or mechanical dynamic troubleshooting), alternative effective protective techniques shall be employed which may require special skills and planning.

Always follow safe operations practices in the workplace.

**EDGER LOCKOUT PROCEDURE**

Lockout procedures must be followed (see ANSI Standard Z244.1-1982 and OSHA regulation 1910.147).

**Purpose:**

This procedure establishes the minimum requirements for lockout of energy sources that could cause injury.

**Responsibility:**

The responsibility for seeing that this procedure is followed is binding upon all workers. All workers shall be instructed in the safety significance of the lockout procedure. It is your responsibility to ensure safe operation of the machine.

**Sequence of Lockout Procedure:**

1. Notify all persons that a lockout is required and the reason therefore.
2. If the edger is operating, shut it down by the normal stopping procedure.
3. Operate the switch so that the energy sources are disconnected or isolated from the edger. Stored energy such as moving blades and feed system shall be dissipated.
4. Lockout the energy isolating devices with assigned individual locks.
5. After ensuring that no persons are exposed and as a check on having disconnected the energy sources, operate the push button or other normal operating controls to make certain the edger will not operate. Caution: Return operating controls to neutral position after the test.
6. The edger is now locked out.

**Restoring Equipment to Service**

1. When the job is complete and the edger is ready for testing or normal service, check the edger area to see that no one is exposed.
2. When the edger is all clear, remove all locks. The energy isolating devices may be operated to restore energy to the edger.

**Procedure Involving More Than One Person**

In the preceding steps, if more than one individual is required to lock out the edger, each shall place his own personal lock on the energy isolating devices.

**Rules for Using Lockout Procedure**

The edger shall be locked out to protect against accidental or inadvertent operation when such operation could cause injury to personnel. Do not attempt to operate any switch or valve bearing a lock.

**Owner's Responsibility**

The procedures listed in this manual may not include all ANSI, OSHA, or locally required safety procedures. It is the owner/operator's responsibility and not Wood-Mizer Products to ensure all operators are properly trained and informed of all safety protocols. Owner/Operators are responsible for following all safety procedures when operating and performing maintenance to the edger.

## SECTION 3 SERVICE

Wood-Mizer is committed to providing you with the latest technology, best quality and strongest customer service available on the market today. We continually evaluate our customers' needs to ensure we're meeting current wood-processing demands. Your comments and suggestions are welcome.

### 3.1 If You Need To Order Parts

From the continental U.S., call our toll-free Parts hotline at **1-800-525-8100**. Please have the vehicle identification number and your customer number ready when you call. Wood-Mizer will accept these methods of payment:

- Visa, Mastercard, or Discover
- COD
- Prepayment
- Net 15 (with approved credit)

Be aware that shipping and handling charges may apply. Handling charges are based on size and quantity of order. In most cases, items will ship on the day they are ordered. Second Day and Next Day shipping are available at additional cost.

If your edger was purchased outside of the United States, contact your distributor for replacement parts.

### 3.2 Customer and Edger Identification

Each Wood-Mizer edger has a 17-digit Vehicle Identification Number (VIN). In addition, when you pick up your edger, you will receive a customer number. These three numbers will help expedite our service to you. Please locate them now and write them below so you have quick, easy access to them. VIN plates can be found in three locations: 1) on the Edger's frame above the hitch receiver tube; 2) inside the gearbox housing below the hour meter; 3) and on the trailer axle (if applicable).

See the following figures for V.I.N. locations.

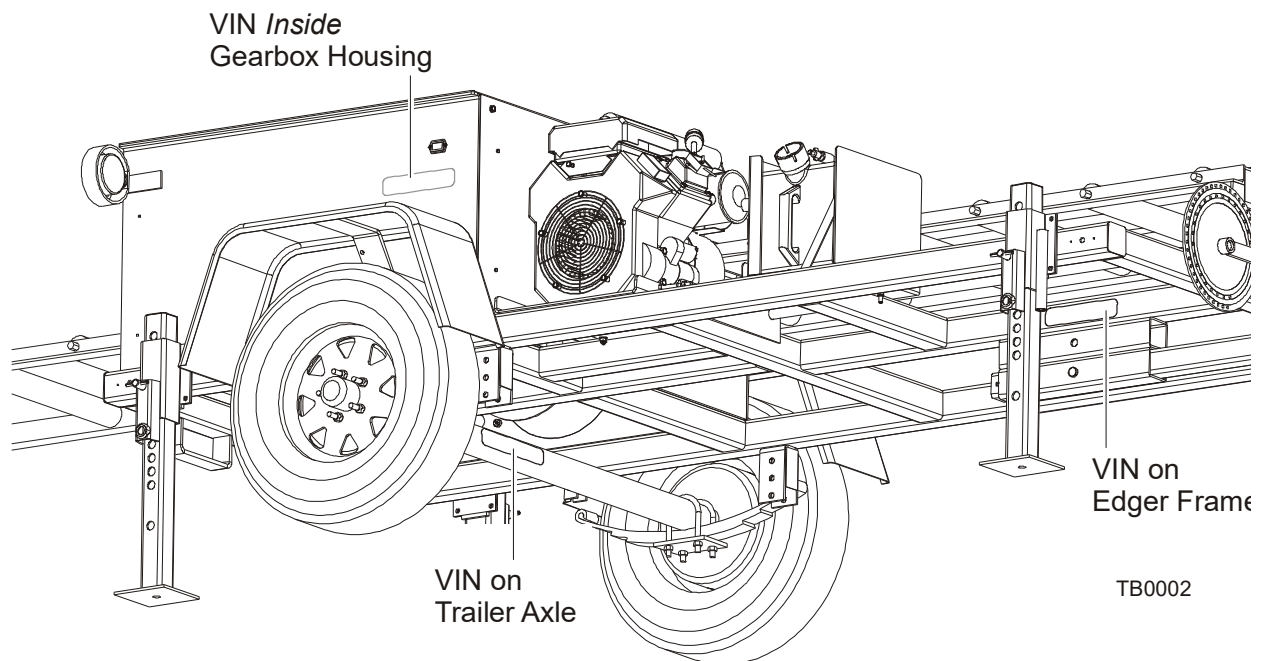

**FIG. 3-1**

(To be filled in by purchaser)  
Edger VIN \_\_\_\_\_  
Customer No. \_\_\_\_\_

### 3.3 If You Need Service

From the continental U.S., call us toll-free at **1-800-525-8100**. Ask to speak with a Customer Service Representative. Please have your vehicle identification number and your customer number ready when you call. The Service Representative can help you with questions about the operation and maintenance of your edger. He also can schedule you for a service call.

**Office Hours:** All times are Eastern Standard Time. Please remember that Indiana does not go on Daylight Savings Time in the summer.

Monday - Friday	Saturday	Sunday
8 a.m. to 5 p.m.	8 a.m. to 12 p.m.	Closed

If your edger was purchased outside the United States, contact the distributor for service.

## SECTION 4 SETUP AND OPERATION

### 4.1 Setup

1. Lower and set the front two outriggers. To lower, use the provided jack handle to lift the weight from the locking pin. If necessary, rotate the locking pin counterclockwise so that the inner roll pin is free from the outrigger channel notch, then pull the locking pin out to release the outrigger. Lower the outrigger as necessary. Push the locking pin back in and turn clockwise until the inner roll pin is behind the outrigger channel notch to “lock” the outrigger in place.

2. Unhitch the Edger from the vehicle.

When towing, the hitch can be used in the upper or lower hitch receiver tube. For storage, however, the hitch must be in the lower hitch receiver tube. To store, move the hitch safety pin to the upper receiver tube. Make sure the hitch lock lever is folded down and slide the hitch all the way back into the lower receiver tube.

3. Lower and set the remaining two rear outriggers.

4. Level the Edger. Adjust the outriggers to raise or lower each end of the Edger as needed. Adjust all outriggers evenly to avoid twisting the Edger frame by jacking one outrigger higher than the other.



**CAUTION!** Use the four outriggers on each corner of the Edger to level the machine prior to operating. Failure to do so can and will affect machine operation and wear life.

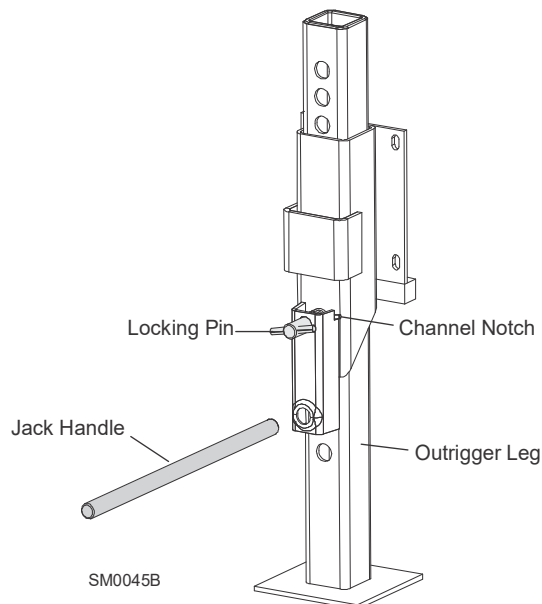

FIG. 4-1

5. Remove the front shipping braces and loosen the rear bolts used to secure the outfeed table in the travel position. Place the outfeed table behind the Edger in the operating position and retighten the rear bolts to secure in place.

Make sure the outfeed table is level with the rest of the Edger. Place blocks under the table if necessary.

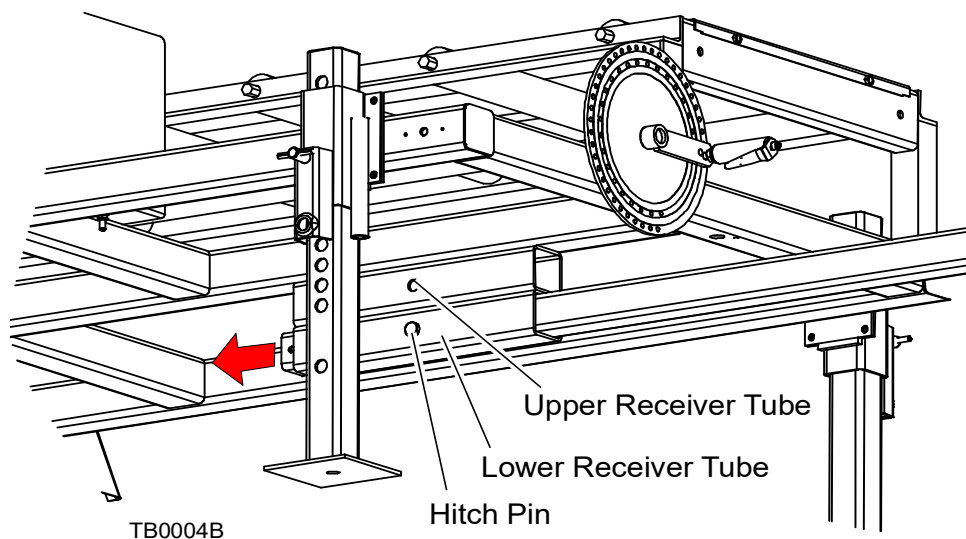

FIG. 4-2

### 4.2 Electrical Installation (EE15 Only)



**DANGER!** Make sure all electrical installation, service and/or maintenance work is performed by a qualified electrician and is in accordance with applicable electrical codes.

**DANGER!** Hazardous voltage inside the electric disconnect box, starter box, and at the motor can cause shock, burns, or death. Disconnect and lock out power supply before servicing! Keep all electrical component covers closed and securely fastened during Edger operation.

Refer to the wiring diagram supplied in the Electrical Information manual for [208-480 Volt motor wiring](#) or [575 Volt motor wiring](#).

Install a fused disconnect switch within sight of the machine. Typical minimum switch, fuse, and wire sizes for use with various operating voltages is shown. Do all installation in accordance with local electrical codes. Fuses are sized for short-circuit protection only. The motor is configured with internal thermostats for overload protection. If an overload condition does occur, the thermostats shut the motor down and the motor cannot be restarted until it cools to a safe operating temperature.

3-Phase Volts	Fuse Disconnect	Time Delay Fuse	Suggested Wire Size
208 VAC	60 Amps	60 Amps	6AWG up to 100'
220 VAC	60 Amps	60 Amps	6AWG up to 100'
240 VAC	60 Amps	60 Amps	6AWG up to 100'
380 VAC	30 Amps	30 Amps	10AWG up to 50'
415 VAC	30 Amps	30 Amps	10AWG up to 50'
440 VAC	30 Amps	30 Amps	10AWG up to 50'
480 VAC	30 Amps	30 Amps	10AWG up to 50'
575 VAC	30 Amps	30 Amps	10AWG up to 50'

**TABLE 4-1**

### 4.3 Pre-Operation Check

Prior to operating the Edger; always perform these basic checks:

1. Make sure the Edger has been properly set up.
2. Make sure the engine drive belt is tensioned properly. [See Section 4.2](#) for more information.



**WARNING!** Do not for any reason adjust the engine drive belts with the engine running. Doing so may result in serious injury.

3. Be sure the anti-kickback fingers are in proper working condition.



**WARNING!** Always ensure that there is a sharp point on the anti-kickback fingers before each use of the Edger.

Be sure anti-kickback fingers are free from obstruction and are in a downward position with lever released. Failure to do so may result in serious injury.

4. Be sure all guards and covers are in place and secured.

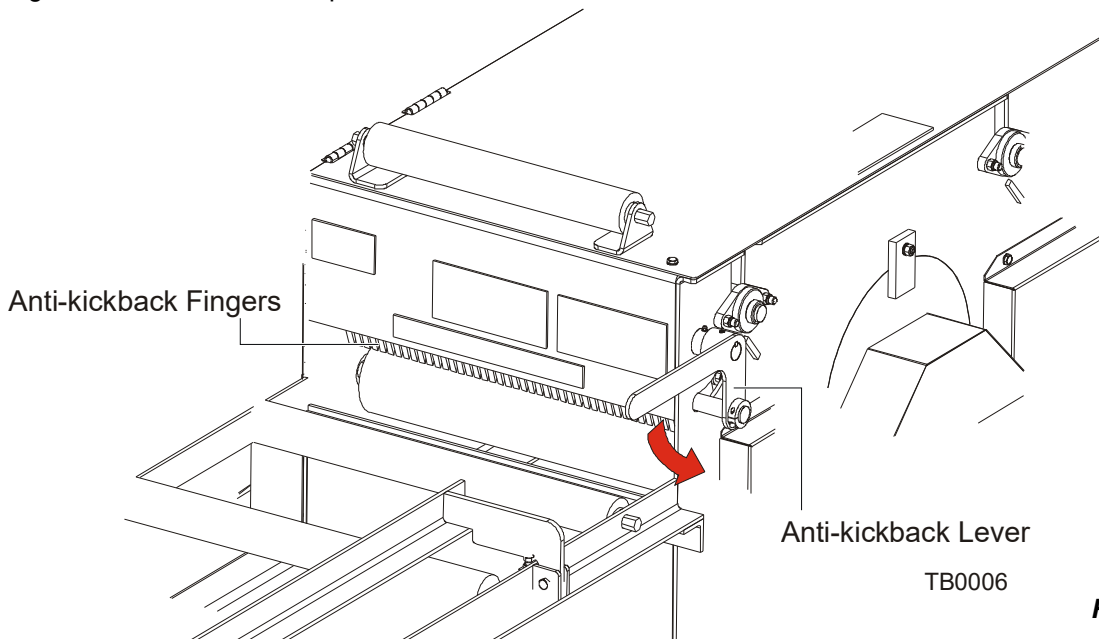

**DANGER!** Make sure all guards and covers are in place and secured before operating or towing the Edger. Failure to do so may result in serious injury.

5. **The blades are spinning whenever the engine is ON.** You should always turn off the engine to stop the blade whenever the Edger is not in use and ensure that all parts have stopped moving before removing any covers or guards.



**WARNING!** Coastdown Required. Always shut off the engine and allow all moving parts to come to a complete stop before removing any guards or covers. Do NOT operate with any guards or covers removed.

**WARNING!** Always shut off the engine to stop the blade whenever the Edger is not in use. Failure to do so may result in serious injury.

An Emergency Stop is located at the front of the Edger, to the left of the Setworks dial. Press the Emergency Stop to shut down the engine. Before operating the Edger again, reset the switch by turning the button to the right and releasing.

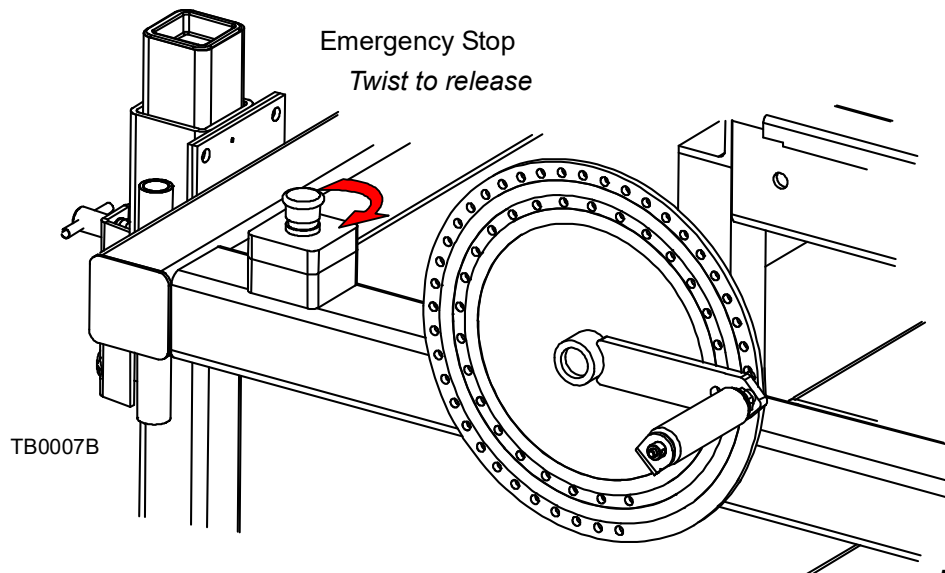



## 4.4 Edging Lumber



**DANGER!** Make sure all guards and covers are in place and secured before operating or towing the Edger. Failure to do so may result in serious injury.

**DANGER!** Keep all persons out of the path of moving equipment and boards when operating the Edger or loading boards. Failure to do so will result in serious injury.

**DANGER!** Moving Parts Can Crush and Cut. Keep hands clear. Make sure all guards and covers are in place and secured before operating or towing. Failure to do so may result in serious injury.

**DANGER!** Maintain a clean and clear path for all necessary movement around the Edger and lumber stacking areas. Failure to do so will result in serious injury.



**WARNING!** Always shut off the engine to stop the blade whenever the Edger is not in use. Failure to do so may result in serious injury.

**WARNING!** Always wear eye, ear, respiration, and foot protection when operating the Edger. Failure to do so may result in serious injury.

**WARNING!** Secure all loose clothing and jewelry before operating the Edger. Failure to do so may result in serious injury or death.

After performing the pre-operation check, you are ready to begin edging lumber. Set the setworks dial indicator for the desired size of boards to be cut.

The setworks dial adjusts the movable saw blade closer to or farther away from the fixed saw blade, thus setting the width of the cut to be made. To set, press the lock release, turn the setworks handle as necessary, and release the lock release into the appropriate labeled hole, from 3" to 15" (or 8 to 38 cm).

For example, setting the dial at 3" will position the movable blade 3" from the fixed blade. Resulting cuts will be 3" in width.

**NOTE:** To change from using U.S. measurements to metric measurements, simply remove the handle from the handle's outer hole and reinstall to the handle's inner hole.

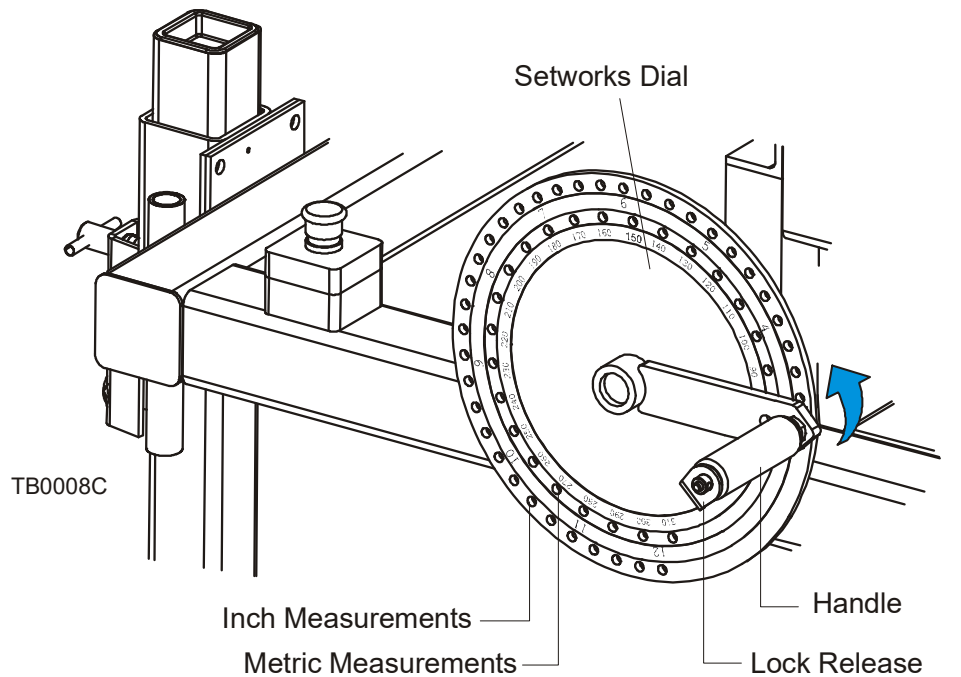

**6.** Set the front fence.

The front fence of the infeed table can be left in place and used as a guide or pivoted up, out of the way.

- 7.** Position a board on top of the infeed rollers.
- 8.** Start the engine. If you have an electric or gas Edger, see the appropriate manual supplied with your specific engine/motor configuration for detailed operating instructions. If you have a ED21 or ED26 diesel Edger, follow the instructions outlined in [Step 9](#).

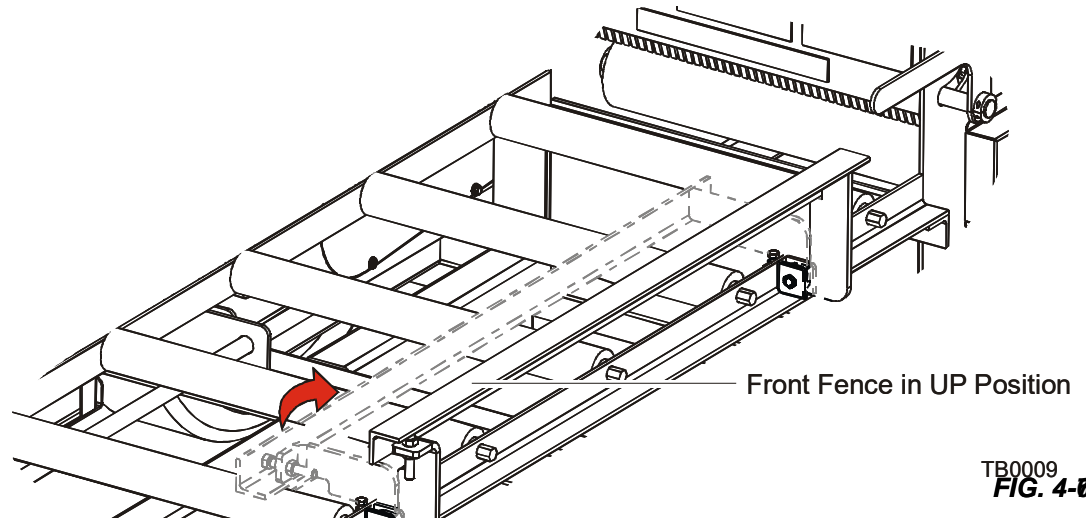

TB0009  
**FIG. 4-6**



**IMPORTANT!** If at any time you need to immediately stop the engine and/or Edger operation, press the Emergency Stop button located at the front of the Edger.

- 9.** To start D21/D26 diesel Edgers, insert the key into the key switch and turn to the preheat (#3) position. Wait the recommended glow plug on time then turn the key to the start (#2) position. As the engine starts, release the key to the run (#1) position.

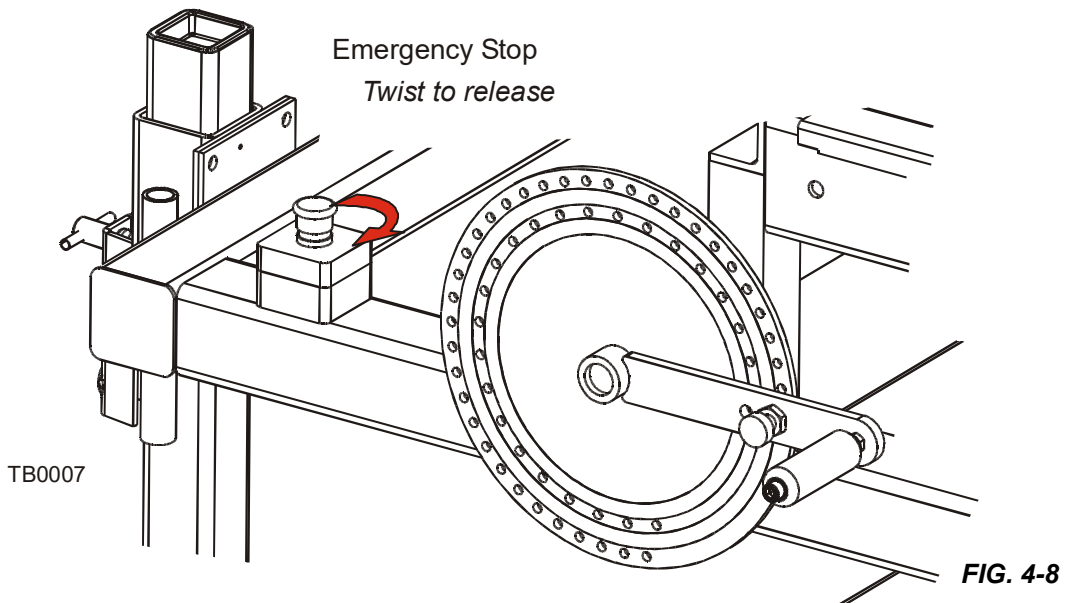

TB0007

**FIG. 4-8**

On Times For Manually Operated Glow Plugs	
Ambient Temperature	Suggested Glow Plug On Time
Less Than 32° F (0° C)	30 Seconds
32 - 60° F (0 -15° C)	25 Seconds
60 - 80° F (15 - 27° C)	15 Seconds
Above 80° F (27° C)	10 Seconds

**TABLE 4-1**

10. Gently push the board through the anti-kickback fingers into the blade until the board begins to feed itself.
11. If the board needs to be edged again, lift the board from the outfeed table. Use the return feed rollers on top of the Edger unit to return the board to the infeed operator.

### 4.5 Preparing the Edger for Towing



**IMPORTANT!** Your vehicle should be equipped with a Class 2 hitch with a solid 2" ball (not two-piece) and rated for at least 3500 pounds (1588 kg). The hitch should be correctly mounted to the towing vehicle so that it will be able to pull this type of load.

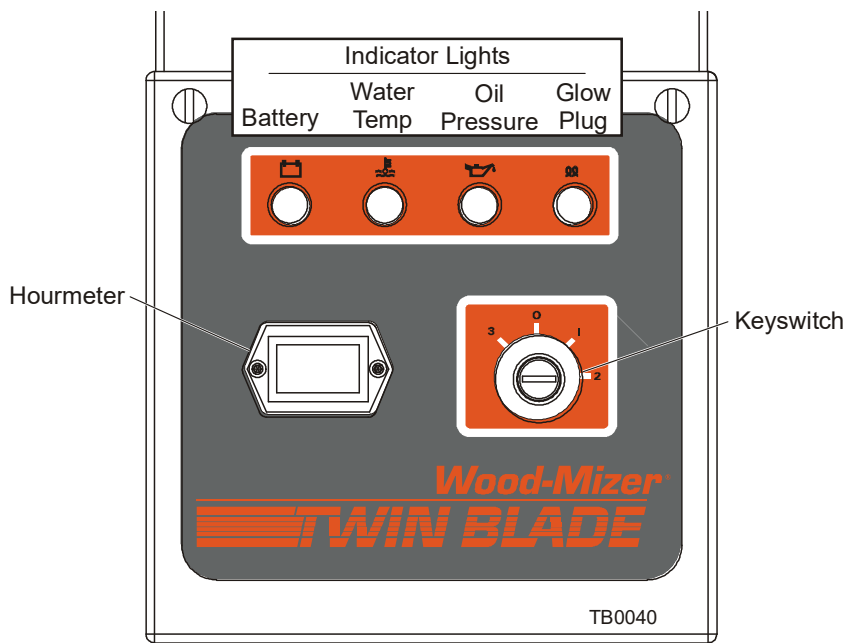
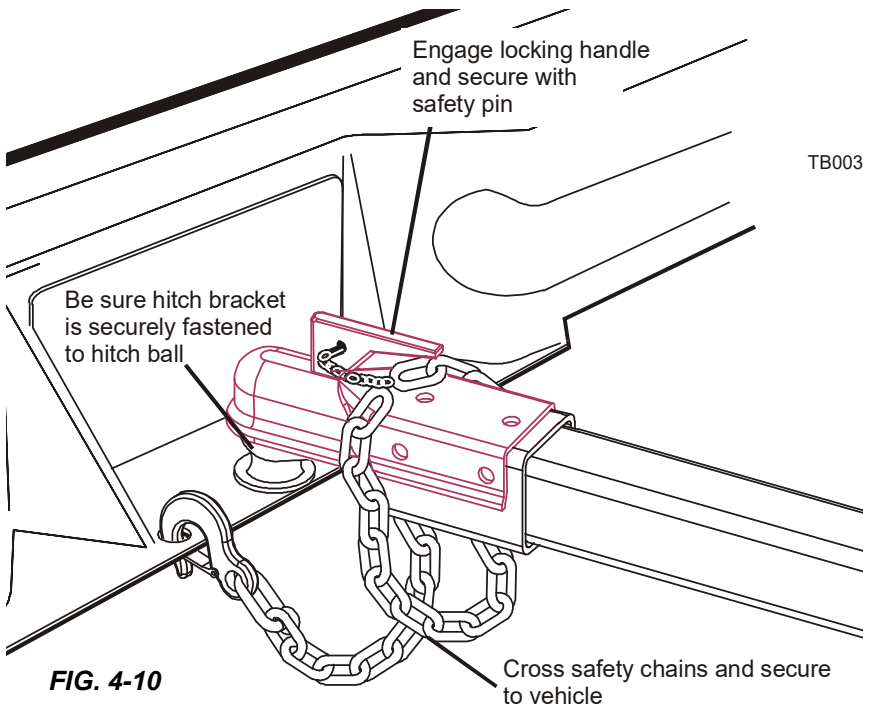

**FIG. 4-9**

1. Unbolt the outfeed table from the rear of the Edger and place on top of the Edger in the travel position. Use the rear bolts and front shipping braces to secure in place.
2. Raise the rear outriggers.
3. Extend the hitch tube from underneath the Edger and secure with the safety pin. Two receiver tubes are provided under the Edger frame to allow for different bumper heights.
4. Pull the edger behind the towing vehicle and place the hitch over the ball coupling on your vehicle. Adjust the coupler if necessary so it is as tight as possible on the ball and the locking lever can still be opened and closed.
5. Flip the locking handle downward, being sure the bracket underneath firmly clamps around the ball.
6. Secure the locking handle with the safety pin.



**DANGER!** Make sure hitch bracket is securely fastened around ball before towing the edger. Ball should be completely engaged by the hitch bracket and securely locked in place. Use the hitch only with the specified ball size. Failure to do so may result in serious personal injury and/or severe machine damage.



**FIG. 4-10**

7. Cross the safety chains underneath the hitch and hook to the vehicle. The chains should be connected so that there is still slack in the chains when the vehicle is turned sharply in either direction.



**DANGER!** Make sure your hitch has adequate safety chain hookups. Do not use eyebolts for safety chain hook-up. Safety chains should be hooked to bumper of vehicle so that each chain would pull the trailer equally in the event the hitch became disengaged. Failure to do so may result in serious personal injury and/or severe machine damage.

8. Connect the 4-pin plug from the edger to the receptacle on your vehicle. Check signals.
9. Raise the front outriggers. Recheck that all loose items are removed or secured.
10. Place both fenders in the slots located behind the trailer tires.



**DANGER!** Be sure that the hitch and safety chains are secure before towing the edger. Failure to do so may result in serious personal injury and/or severe machine damage.

**DANGER!** Make sure all light connections have been made and are working properly before towing the edger. Failure to do so may result in serious personal injury and/or severe machine damage. Make sure you have complied with all applicable Federal, State and Local motor vehicle safety laws.

**DANGER!** Chock the edger to prevent movement before unhitching it from the towing vehicle. Failure to do so may result in serious injury or death.



**CAUTION!** Always check trailer tires for proper inflation before towing edger. Failure to do so may result in machine damage.

## SECTION 5 MAINTENANCE

Refer to the engine manufacturer's manual for maintenance intervals and procedures regarding the power supply unless otherwise instructed in this manual. Follow the manufacturer's recommendations for dusty conditions.



**IMPORTANT!** This manual only provides information about additional procedures or procedures to be performed at different time intervals than found in the manufacturer's manuals. Refer to the manufacturer's manual for complete maintenance instructions.

### 5.1 Changing the Blades

Replace the blades as necessary. Dull blades will cause the engine to work harder and will result in decreased cut quality and accuracy. Blade life will vary depending on maintenance of machine, operator, species of wood being sawn, and condition of wood being sawn.



**DANGER!** Before changing the blades, make sure the arbor has come to a complete stop and the motor is shut off completely. Failing to do so can cause serious injury.



**WARNING!** Always wear eye, glove and foot protection when handling saw blades.

1. To access the blades, unbolt and open the blade housing cover.
2. Loosen the blade locking nut set screws.
3. Remove the blade shaft bearing plate assembly from the Edger. To remove, first unbolt and remove the blade shaft end guard. Loosen the blade bearing retaining bolt. Remove the three lock washers and hex nuts on the bearing plate and pry the plate from the Edger.
4. Next, remove the blades from the shaft. Remove the fixed blade locking nut and the fixed blade. Loosen the two hex screws on the fixed blade arbor and remove the arbor from the shaft.

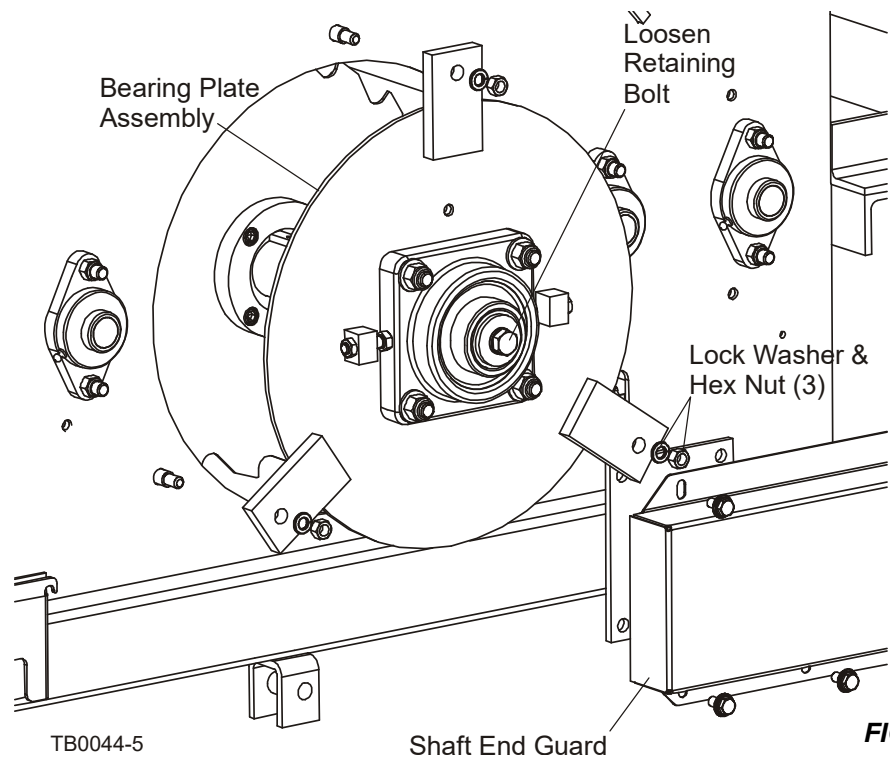
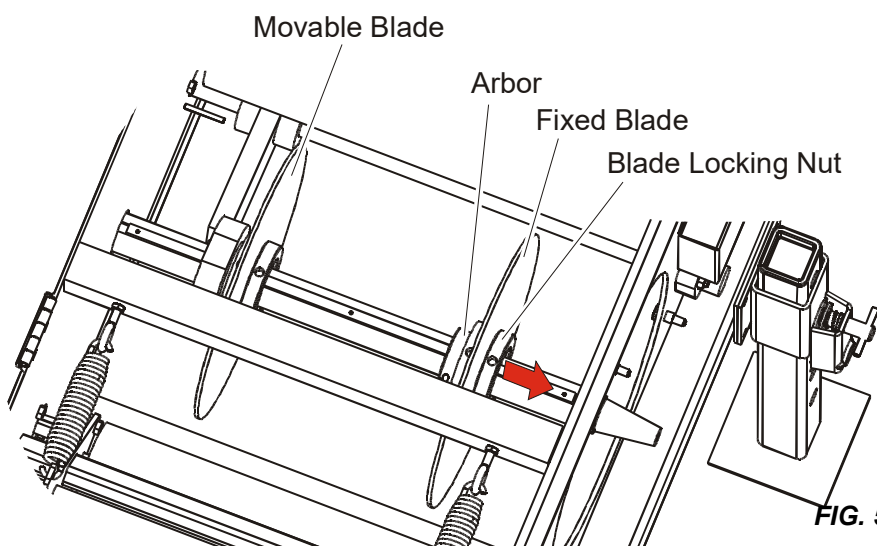



FIG. 5-1

5. Unscrew and remove the adjustable blade locking nut. Slide the movable blade from the shaft.
6. Apply an anti-seize lubricant to the face of the arbor and to the face and threads of the blade locking nut.
7. Install a new or resharpened blade to shaft and position it next to the movable blade arbor. Loosely reinstall the adjustable blade locking nut.
8. Reinstall the fixed blade arbor to the shaft. Install a new or resharpened blade, and loosely reinstall the fixed blade locking nut.
9. Reinstall the bearing plate assembly and secure in place with the lock washers and hex nuts. Tighten the bearing retaining bolt.
10. Reinstall blade shaft end guard.
11. Tighten the blade locking nut set screws.
12. Align the blades. [See Section 4.8.](#)
13. During alignment, the blade arbor hex screws will be tightened to secure the blade assemblies in place.
14. After alignment, be sure to close and re-secure the blade housing cover.



## 5.2 Tensioning the Belts

 **DANGER!** Always shut off the engine and allow all moving parts to come to a complete stop before removing any guards or covers. Failure to do so will result in serious injury.

 **WARNING!** Do not for any reason adjust the engine drive belts with the engine running. Doing so may result in serious injury.

 **CAUTION!** Never apply belt dressing as this will damage the belt and cause early failure.

1. Check the drive belt for wear every 8 hours of operation and more frequently during the first 24-48 hours of operation. Tension or replace as necessary:

**EG200EC15/EG200G26:** Tension should be 9/16" deflection with 9 lbs of force for new belts or 9/16" deflection with 6 lbs of force for used belts.

**EG200ED21/EG200ED26:** Tension should be 17/32" deflection with 8 - 12 lbs of force.

To tension the drive belt:

- Unbolt and open the gearbox housing cover.
- Locate the mounting bolts which secure the drive belt guard to the gearbox housing. Loosen these so that the drive belt housing is free to slide as necessary.
- Loosen the four engine mounting bolts.
- Use the two adjustment bolts as shown to move the engine mount towards the front of the Edger until the belt is properly tensioned. Be sure to adjust the bolts evenly so the motor remains in alignment.

 **CAUTION!** Do not over tighten the drive belt as it can cause premature belt and/or bearing failure.



**CAUTION!** Do not under-tighten the drive belt as it can cause one or all of the following damages: slippage of the belt on the drive pulley, binding or fetching up of the saws while in the cut, damage or bending of saws

2. Retighten the engine mounting bolts.
3. Retighten the belt guard mounting bolts.
4. Check the idler belt for wear every 8 hours of operation. Tension or replace as necessary. Tension should be 1/8" deflection with 9 lbs of force for new belts or 1/8" deflection with 6 lbs of force for used belts.

To tension the idler belt:

- With the gearbox housing cover still open, locate the idler drive bracket. Loosen the bottom mounting bolt first, then the top adjustment bolt.
- Push the bottom of the bracket towards the idler pulley until the belt is tensioned as needed.

5. Retighten the top adjustment bolt and the bottom idler bracket mounting bolt.
6. Close the gearbox housing cover and use the existing bolts to secure.

### 5.3 Tensioning the Chains

Check the drive chains for tension every 40 hours of operation and tension as necessary. The chains should have approximately 1/2" of slack. **NOTE:** The smaller idler chains have no adjustment.

To tension the drive chains, unbolt and open the gearbox housing cover.

- Loosen the four gearbox mounting bolts.
- Use the adjustment bolts underneath the gearbox to raise the gearbox until the chains are tensioned as needed. Be sure to adjust the bolts evenly.

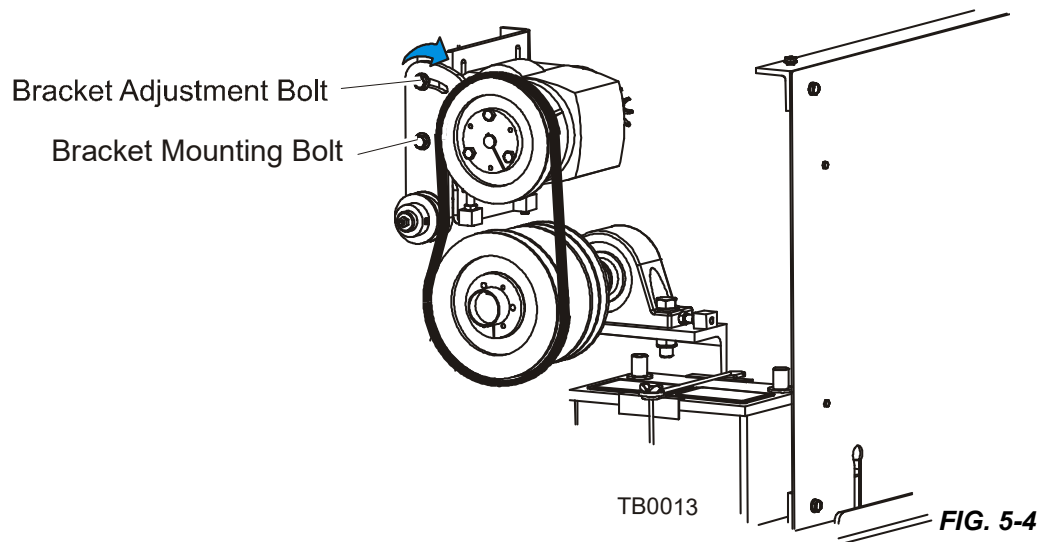
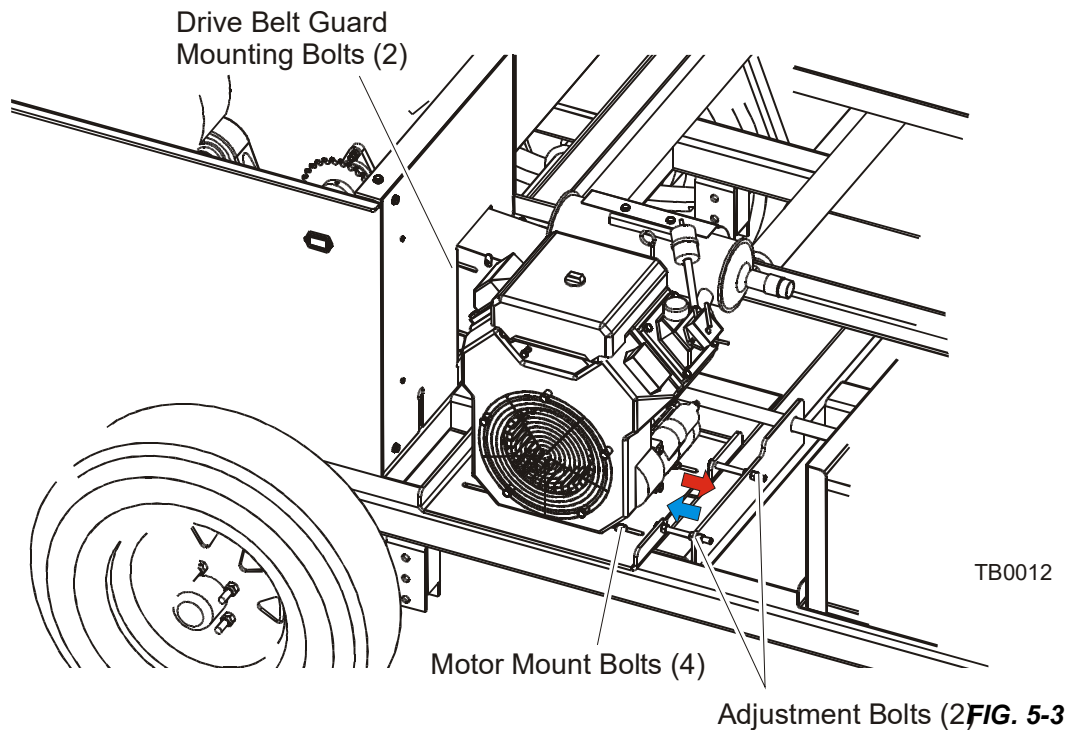

Retighten the gearbox mounting bolts and close and secure the gearbox housing cover.

## 5.4 Checking the Rollers

1. Check the feed rollers every 8 hours of operation. Remove any dirt or debris from the rollers. Make sure they spin freely, without much play. Replace the spring-loaded feed rollers as needed.
2. Check the press rollers every 8 hours of operation. Clean any debris or sap buildup from the rollers with a wire brush. Replace the press roller bearings if there is any play in the rollers.

## 5.5 Lubrication

1. Clean any debris from the blade drive shaft and every 8 hours of operation. Use a soft cloth to apply a dry graphite daily to ensure resistance-free motion and to prevent surface corrosion.

Also, clean debris from the rack and pinion every 8 hours of operation. Lubricate with dry graphite.

2. Lubricate the blade shaft bearings every 200 hours of operation with one to two pumps of lithium-based grease such as Shell Alvania No. 3. Do not overgrease.
3. Lubricate the anti-kickback shaft pivots every 200 hours of operation with a high-quality lithium-based grease such as Shell Alvania No. 3.
4. Lubricate the press roller bearings every 200 hours of operation with a high-quality lithium-based grease such as Shell Alvania No. 3.
5. Lubricate the Setworks dial every 200 hours of operation with a high-quality lithium-based grease such as Shell Alvania No. 3.
6. Apply anti-seize lubricant to the surfaces and threads of the blade arbors and locking nuts every blade change ([See Section 5.1](#)).

## 5.6 Maintaining and Sharpening Anti-Kickback Fingers

This machine has the potential for kick-backs. Kick-backs can cause the board to be suddenly and uncontrollably hurled towards the operator. Such action can result in severe injury or death.

If you are working with frozen boards or with boards that have protruding knots, the chance of kickbacks is increased.

The infeed opening of the Edger is equipped with anti-kickback fingers to help prevent kickback from occurring. To maintain the safety of your Edger, periodically inspect the machine to ensure all anti-kickback fingers are intact and undamaged and have a sharp point. Missing or damaged parts can affect the safety of the machine operator or bystanders and should be replaced immediately. Dulled parts should be re-ground with a hand grinder or replaced.



**DANGER!** Always ensure that there is a sharp point on the anti-kickback fingers before each use of the Edger.

Be sure anti-kickback fingers are free from obstruction and are in a downward position with lever released. Failure to do so may result in serious injury.

## 5.7 Alignment



**WARNING!** Before performing service near moving parts such as blades, pulleys, motors, belts and chains, first turn the engine key switch to the OFF (#0)

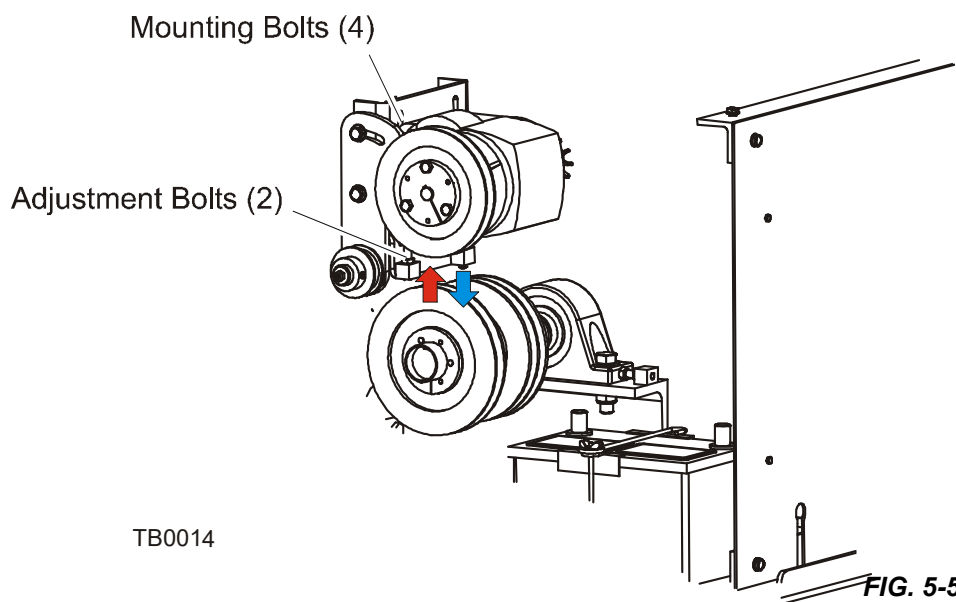



position and remove the key. If the key is turned on and moving parts activated, serious injury may result.

**WARNING!** Coastdown Required. Always shut off the engine and allow all moving parts to come to a complete stop before removing any guards or covers. Do NOT operate with any guards or covers

1. Make sure the blade housing cover is open and the blade locking nuts and arbors are loose.
2. Run a string (or straight edge) from the front of the Edger frame to the back. The string should pass directly underneath the "zero" mark on the fixed blade scale and should be parallel to the blades.
3. Move the fixed blade assembly until the inside face of the blade is against the string.

Tighten the fixed blade arbor hex screws to secure the assembly in place.

4. Next, use the front fence adjustment bolt to adjust the front fence parallel with the string.
5. To position the adjustable blade, set the setworks dial at 3". Measure from the inside of the fixed blade to the inside of the movable blade. If necessary, loosen the movable blade arm and slide the blade assembly on the shaft until the blades are 3" apart. Retighten the blade arm and tighten the arbor hex screws to secure in place.

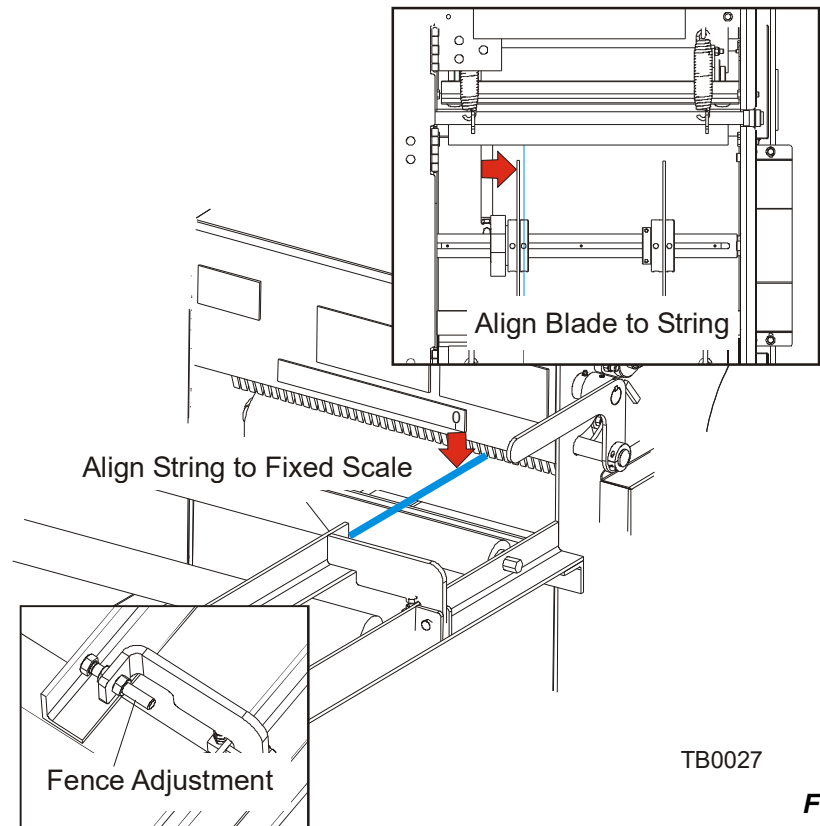

TB0027

**FIG. 5-6**

## SECTION 6 TROUBLESHOOTING

### 6.1 Boards Are Not Self-Feeding



**DANGER!** Always shut off the engine and allow all moving parts to come to a complete stop before removing any guards or covers.

1. If boards are not self-feeding, increase the tension on the top press rollers.
2. To do this, unbolt and open the blade housing cover.
3. Locate the four horizontal springs which provide tension to the press rollers.
4. Tighten the tension spring eyebolts until sufficient tension is placed on the top press rollers. Always use the lowest amount of tension that still enables boards to feed properly. Too much tension on soft wood can mar the wood.



**CAUTION!** Do not overtension as this can affect wear life and can cause the rollers to mar the surface of some of the softer woods.

5. Close and secure the blade housing cover.

### 6.2 Jammed Boards



**DANGER!** Always shut off the engine and allow all moving parts to come to a complete stop before removing any guards or covers.

1. If a board becomes jammed, temporarily remove press roller tension to release the board.
2. To do this, unbolt and open the blade housing cover.
3. Loosen the nuts on the tension spring eyebolts until enough tension has been released to remove the jammed board.

You may need to use cant hooks to lift the press rollers enough to remove the board. It may also be necessary to lift the anti-kickback fingers by pushing the kickback lever down.

4. Retighten the nuts until the top press rollers are properly tensioned. Always use the lowest amount of tension that still enables boards to feed properly. Too much tension on soft wood can mar the wood.



**CAUTION!** Do not overtension as this can affect wear life and can cause the rollers to mar the surface of some of the softer woods.

Close and secure the blade housing cover.