

Parts Manual

Twin Vertical Saw (TVS) rev. B3.00

Safety is our #1 concern!

Form #1674

Models Effected:

TVSEC15U-FT-3.6, Twin Vertical Saw, 15HP Elec 3.6M Flat F

TVSEC15U, Twin Vertical Saw, 15hp Elec 480v/60hz

TVSEC15U-FT2.4, Twin Vertical Saw, 15HP Elec Spiky Feed

TVSEC15U-SC2.4-SD, Twin Vertical Saw, 15HP Elec Spiky Feed

TVSEC15U-SC3.6-SD, Twin Vertical Saw, 15HP Elec Spiky Feed



WARNING! Read and understand this manual before using this machine.

SECTION 1 REPLACEMENT PARTS

1.1 How To Use The Parts List1-1
 1.2 Sample Assembly1-1

SECTION 2 BLADE GUIDE ROLLERS & ARM

2.1 Blade Guide Assembly, Idle Side.....2-1
 2.2 Blade Guide Assembly, Drive Side.....2-3

SECTION 3 BLADE WHEELS & TENSIONER

3.1 Blade Wheel Assembly, Drive Side3-1
 3.2 Blade Wheel Assembly, Idle Side3-2
 3.3 Blade Tensioner Assembly.....3-3
 3.4 Blade Tensioner Pump Assembly3-5

SECTION 4 SAW HEAD

4.1 Middle Throat Screw4-1
 4.2 Water Lube Assembly (LMS)4-2
 4.3 Saw Head Decals.....4-4
 4.4 Blade Housing Cover4-5
 4.5 Saw Head Width Manual Adjustment Assembly4-7
 4.6 Saw Head Width Automatic Adjustment Assembly (Optional).....4-9
 4.7 Saw Head Width Indicator4-12
 4.8 Saw Head Slide Brackets.....4-13
 4.9 Hold-Down Roller4-14
 4.10 Blade Drive Motor.....4-16
 4.11 Saw Head Support Rollers.....4-17
 4.12 Main Control Assembly4-18
 4.13 Operator Control Box Assembly4-19
 4.14 Laser Assembly (Optional).....4-20

SECTION 5 INFEED & OUTFEED TABLES

5.1 TVS Infeed5-1
 5.2 Infeed Table Chain Tension Wheel.....5-5
 5.3 Chain Drive Assembly, TVS5-6
 5.4 TVS Outfeed.....5-8
 5.5 Additional Hold-Down Roller Kit (Optional)5-11
 5.6 Tables Decals.....5-13

SECTION 6 INCLINE LOG DECK

6.1 Infeed Assembly6-1
 6.2 Limit Switch Assembly6-3
 6.3 Drive Assembly6-4
 6.4 Chain Guards6-6
 6.5 Decals6-7

SECTION 7 CROSS TRANSFER DECK

7.1 Front Module & Chains.....7-1
 7.2 Central Module.....7-2

Table of Contents

Section-Page

7.3	Rear Module	7-3
7.4	Cross Transfer Deck Drive	7-4
7.5	Leg Kits.....	7-5
7.6	Slabs Table.....	7-6
7.7	Decals.....	7-8

SECTION 1 REPLACEMENT PARTS

1.1 How To Use The Parts List

- Go to the appropriate section and locate the part in the illustration.
- Use the number pointing to the part to locate the correct part number and description in the table.
- Parts shown indented under another part are included with that part.
- Parts marked with a diamond (◆) are only available in the assembly listed above the part.

See the sample table below. Sample Part #A01111 includes part F02222-2 and subassembly A03333. Subassembly A03333 includes part S04444-4 and subassembly K05555. The diamond (◆) indicates that S04444-4 is not available except in subassembly A03333. Subassembly K05555 includes parts M06666 and F07777-77. The diamond (◆) indicates M06666 is not available except in subassembly K05555.

1.2 Sample Assembly				
REF	DESCRIPTION (◆ Indicates Parts Available In Assemblies Only)	PART #	QTY.	
	SAMPLE ASSEMBLY, COMPLETE (Includes All Indented Parts Below)	A01111	1	
1	Sample Part	F02222-22	1	
2	Sample Subassembly (Includes All Indented Parts Below)	A03333	1	
	Sample Part (Indicates Part Is Only Available With A03333)	S04444-4	1	◆
3	Sample Subassembly (Includes All Indented Parts Below)	K05555	1	
	Sample Part (Indicates Part Is Only Available With K05555)	M06666	2	◆
4	Sample Part	F07777-77	1	

To Order Parts:

From the continental U.S., call **1-800-525-8100** to order parts. Have your customer number, VIN, and part numbers ready when you call. From other international locations, contact the Wood-Mizer distributor in your area for parts.

SECTION 2 BLADE GUIDE ROLLERS & ARM

2.1 Blade Guide Assembly, Idle Side

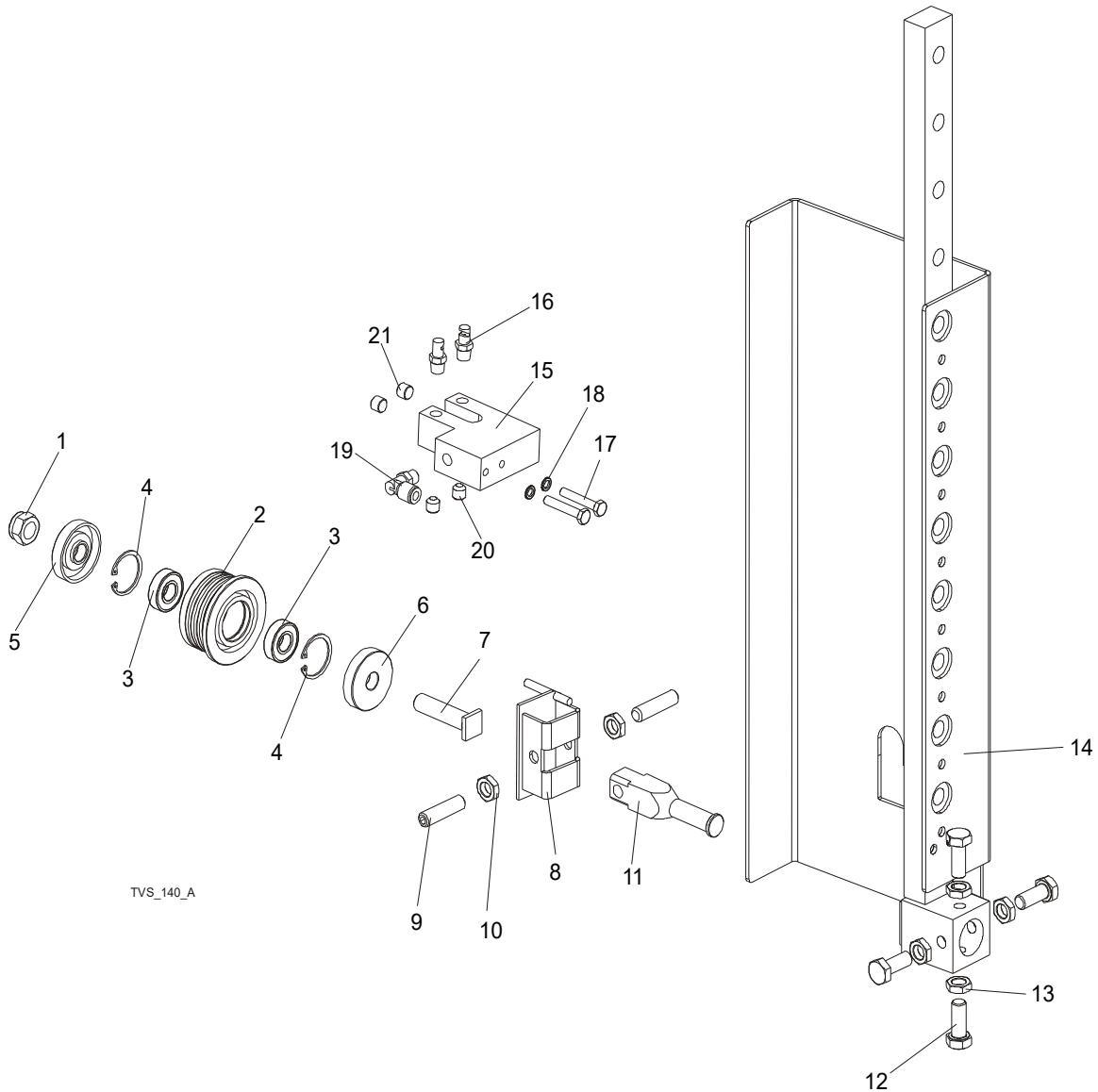

REF	PART #	DESCRIPTION	COMMENTS	QTY.
	500562	ROLLER, TVS BLADE GUIDE COMPLETE		1
	500561	Roller, TVS Blade Guide		1

2

Blade Guide Rollers & Arm*Blade Guide Assembly, Idle Side*

REF	PART #	DESCRIPTION	COMMENTS	QTY.
1	F81034-2	Nut, M12-8 Hex Nylon Zinc Lock		1
2	500560	Roller, TVS Blade Guide Wide	Available in assemblies only.	1
3	087893	Bearing, 6001 2rsr Fag		2
4	F81090-9	Ring, W28 Inside Retaining		1
5	087891-1	Ring, Zinc-plated Spacer (For Extend.roll)		1
6	087892-1	Ring, Zinc-plated Spacer (For Extend.roll)		1
7	087762-1	Shaft, Blade Guide Roller Zinc-plated		1
8	500563-1	Bracket Weldment, Blade Guide Painted		1
9	F81015-2	Screw, M10x1x40 Din 913 A2-70 Set Stainless Steel		2
10	F81033-10	Nut, M10x1-04-st-a2 Iso 8675 Thin		2
11	088255-1	Shaft, Blade Guide Mount Zinc-plated		1
12	F81003-28	BOLT, M10X1X25 DIN 933		4
13	F81033-10	NUT, M10X1-04-ST-A2 ISO 8675 THIN		4
14	508387-1	ROLLER GUIDE, TVS RIGHT-PTD		1
	508390-1	ROLLER GUIDE, TVS LEFT-PTD		1
	098583	LUBE SYSTEM, TVS		2
15	097943-1	Block, Nozzle Mounting Zinc-plated		1
16	033479	Nozzle, Blade Lube Spray		2
17	F81001-71	Bolt, M6x35 8.8 Hex Head Zinc		2
18	F81053-3	Washer, M6 Split Lock Zinc		2
19	P09736	Fitting, 1/8" MPTx1/4" Tube,elbow,swivel		1
20	P30127	Fitting, 1/8" NPT Socket Pipe Plug		2
21	F81015-3	Plug, M10x1 Din 906 Bn40 "Bossard"		2

2.2 Blade Guide Assembly, Drive Side

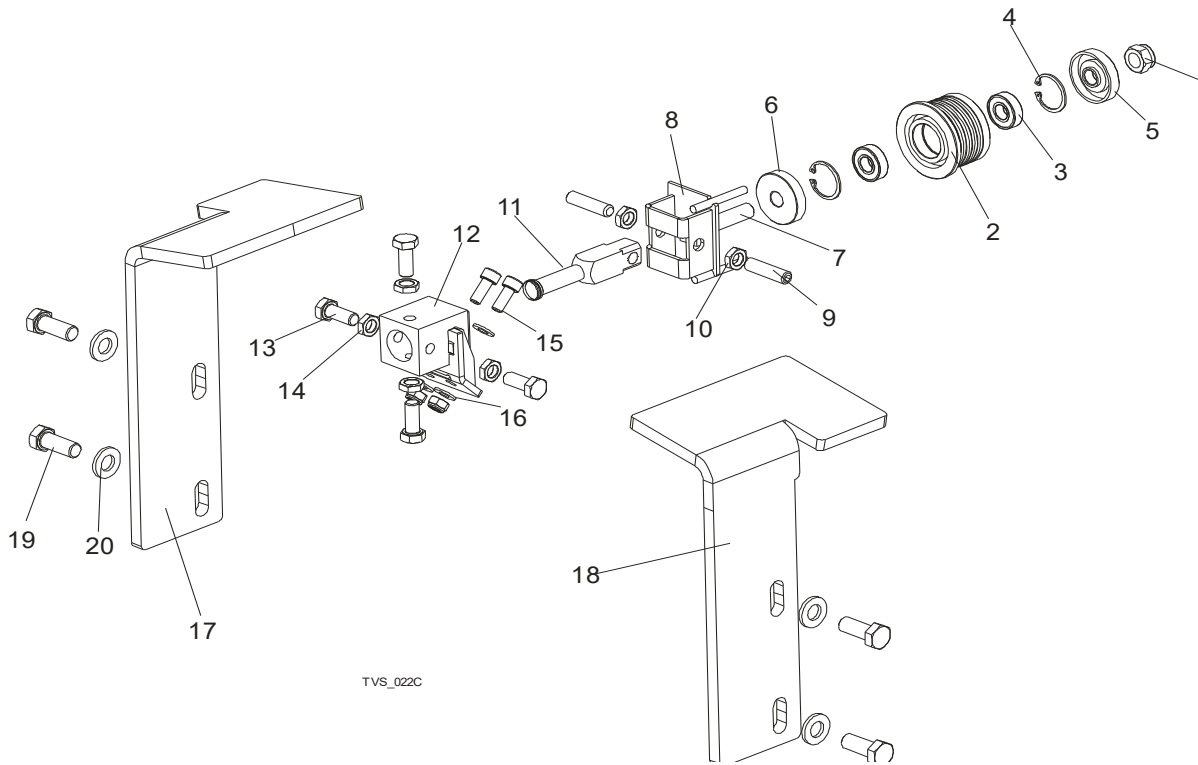

TVS_022C

REF	PART #	DESCRIPTION	COMMENTS	QTY.
	500562	ROLLER, TVS BLADE GUIDE COMPLETE		1
	500561	Roller, TVS Blade Guide		1
1	F81034-2	Nut, M12-8 Hex Nylon Zinc Lock		1
2	500560	Roller, TVS Blade Guide Wide	Available in assemblies only.	1
3	087893	Bearing, 6001 2RSR Fag		2
4	F81090-9	Ring, W28 Inside Retaining		1
5	087891-1	Ring, Zinc-plated Spacer (For Extend.roll)		1
6	087892-1	Ring, Zinc-plated Spacer (For Extend.roll)		1
7	087762-1	Shaft, Blade Guide Roller Zinc-plated		1
8	500563-1	Bracket Weldment, Blade Guide Painted		1
9	F81015-2	Screw, M10x1x40 Din 913 A2-70 Set Stainless Steel		2
10	F81033-10	Nut, M10x1-04-st-a2 Iso 8675 Thin		2
11	088255-1	Shaft, Blade Guide Mount Zinc-plated		1
12	514887-1	BLOCK WELDMENT, PAINTED BLADE GUIDE MOUNT		3

2**Blade Guide Rollers & Arm***Blade Guide Assembly, Drive Side*

REF	PART #	DESCRIPTION	COMMENTS	QTY.
13	F81003-28	BOLT, M10X1X25 DIN 933 STAINLESS STEEL		1
14	F81033-10	NUT, M10x1-04-ST-A2 ISO 8675 THIN		4
15	F81002-30	BOLT, M8 X 20-8.8 SOCKET HEAD		2
16	F81054-4	WASHER, 8.2 SPLIT LOCK ZINC		2
17	097660-1	COVER, DRIVE SIDE ROLLER RIGHT		1
18	098435-1	COVER, DRIVE SIDE ROLLER LEFT		1
19	F81004-22	BOLT M12x30-8.8		4
20	F81056-1	WASHER, M12 , FLAT, ZINC		4

SECTION 3 BLADE WHEELS & TENSIONER

3.1 Blade Wheel Assembly, Drive Side

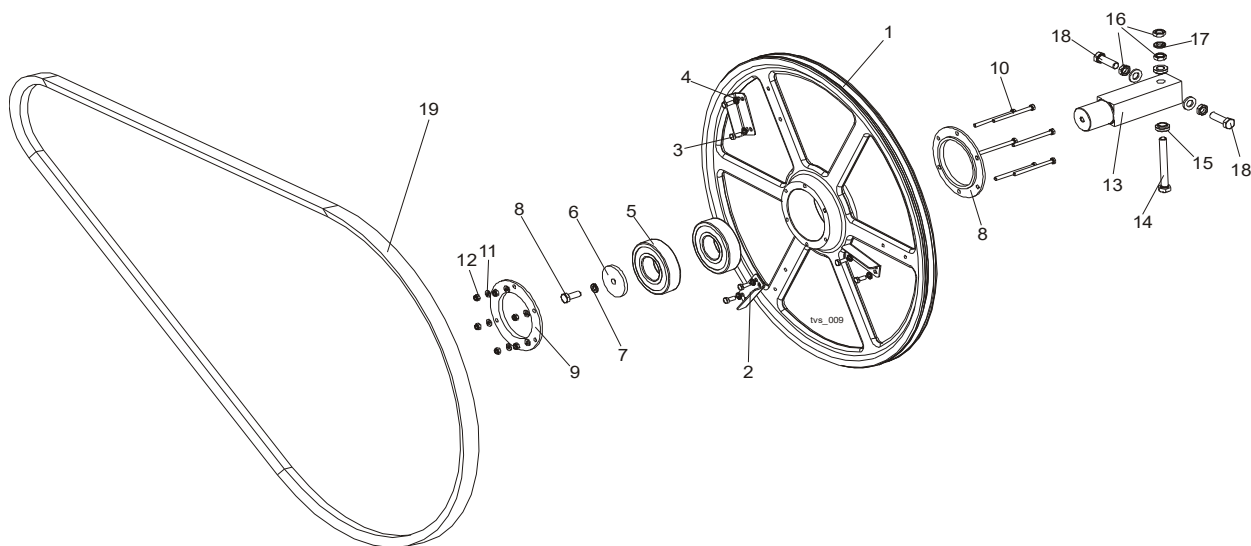

REF	PART #	DESCRIPTION	COMMENTS	QTY.
	096109	DRIVE WHEEL, TVS, COMPLETE		1
1	096105-1	Drive Blade Wheel		1
2	097808-1	Wing, TVS		3
3	F81001-15	Bolt, M6 x 16 8.8 Fe/Zn5 PN-M/82105		6
4	F81053-3	Washer, M6 Split Lock Zinc		6
5	096107	Bearing 6309 2RSR		2
6	088957-1	Washer, Idle Blade Wheel Retaining		1
7	F81055-2	Washer, M10 Split Lock zinc		1
8	F81003-31	Bolt, M10X25 8.8 Hex Head Full Thread		1
9	096108-1	Ring, Bearing Mounting		2
10	F81001-61	Bolt, M6x80 Fe/Zn5		6
11	F81053-1	Washer, M6, Flat, zinc		6
12	F81031-2	Nut, M6, Hex, Nylon Lock zinc		6
13	096110	AXLE, DRIVE WHEEL, TVS		1
14	F81004-41	BOLT, M12X1.25X100-8.8 HEX HEAD ZINC		1
15	086769-1	SPACER, BLADE GUIDE		2
16	F81034-5	NUT, M12X1.25 8.8 HEX ZINC THIN		3
17	F81056-2	WASHER, M12 SPLIT LOCK ZINC		1
18	F81004-42	BOLT, M12X1.25X40 HEX HEAD		2
19	033391	DRIVE BELT, 5VX1080		1

3 Blade Wheels & Tensioner

Blade Wheel Assembly, Idle Side

3.2 Blade Wheel Assembly, Idle Side

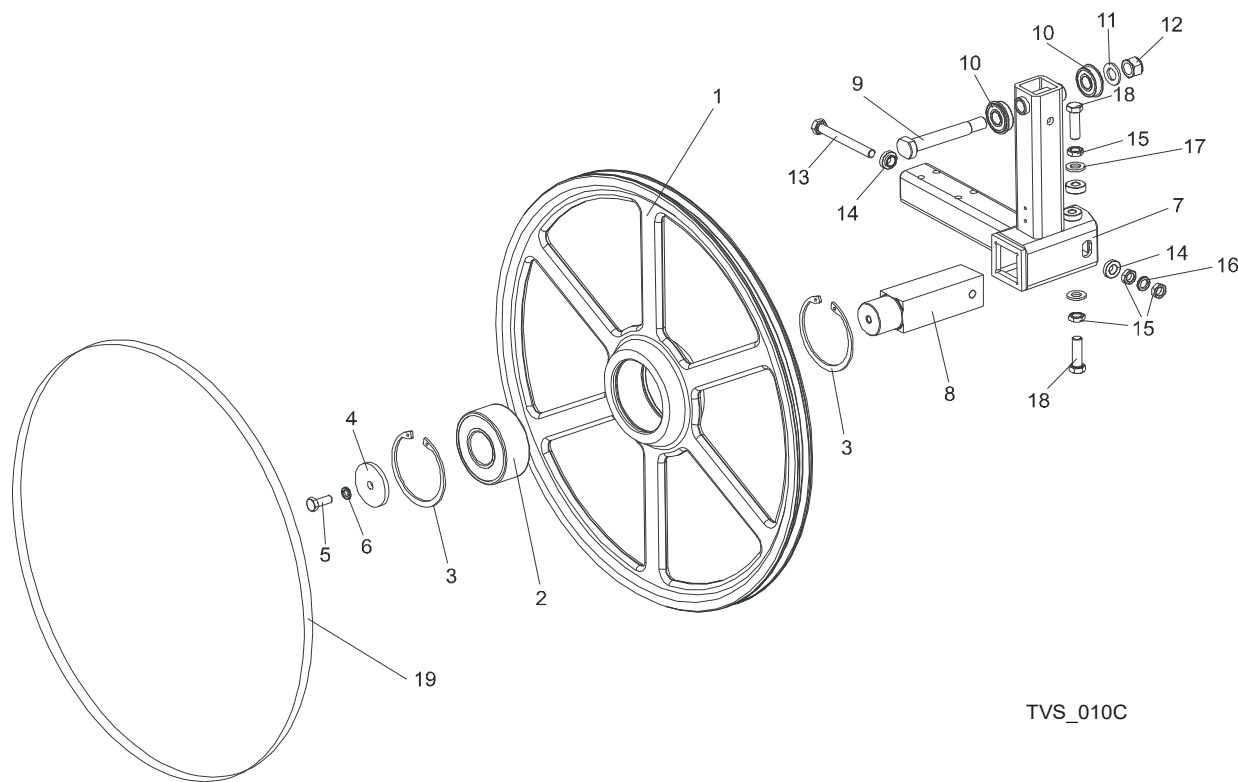

TVS_010C

REF	PART #	DESCRIPTION	COMMENTS	QTY.
	088764	WHEEL ASSEMBLY, IDLE SIDE BLADE		1
1	090810-1	Wheel, Idle Side, ptd		1
2	086428	Bearing, 3309B.2RSR.TVH FAG		1
3	F81090-10	Ring, W100 Inside Retaining		2
4	088957	WASHER, BLADE WHEEL RETAINING ZINC-PLATED		1
5	F81003-31	BOLT, M10X25 8.8 HEX HEAD FULL THREAD		1
6	F81055-2	WASHER, 10.2 SPLIT LOCK ZINC		1
7	504816-1	ARM WELDMENT, TVS IDLE LEFT SIDE BLADE WHEEL		1
	504817-1	ARM WELDMENT, TVS IDLE RIGHT SIDE BLADE WHEEL		1
8	088474	SHAFT, IDLE SIDE BLADE WHEEL		1
9	086404	BOLT, ARM BEARING MOUNT		1
10	086395	BEARING, 6203-2RS NR NSK W/SNAP RING		2
11	F81058-1	WASHER, 17 FLAT ZINC		1
12	F81036-2	NUT, M16-8 HEX NYLON ZINC LOCK		1

REF	PART #	DESCRIPTION	COMMENTS	QTY.
13	F81004-41	BOLT, M12X1.25X100-8.8 HEX HEAD FULL THREAD ZINC		1
14	086769-1	WASHER, FLANGED ZINC-PLATED		2
15	F81034-5	NUT, M12X1.25 8.8 HEX THIN ZINC		4
16	F81056-2	WASHER, Z12.2 SPLIT LOCK ZINC		1
17	F81056-1	WASHER, 13 FLAT ZINC		2
18	F81004-42	BOLT, M12X1.25X40-8.8 HEX HEAD FULL THREAD ZINC		2
19	017922-1	BELT, B72.5		1

3.3 Blade Tensioner Assembly

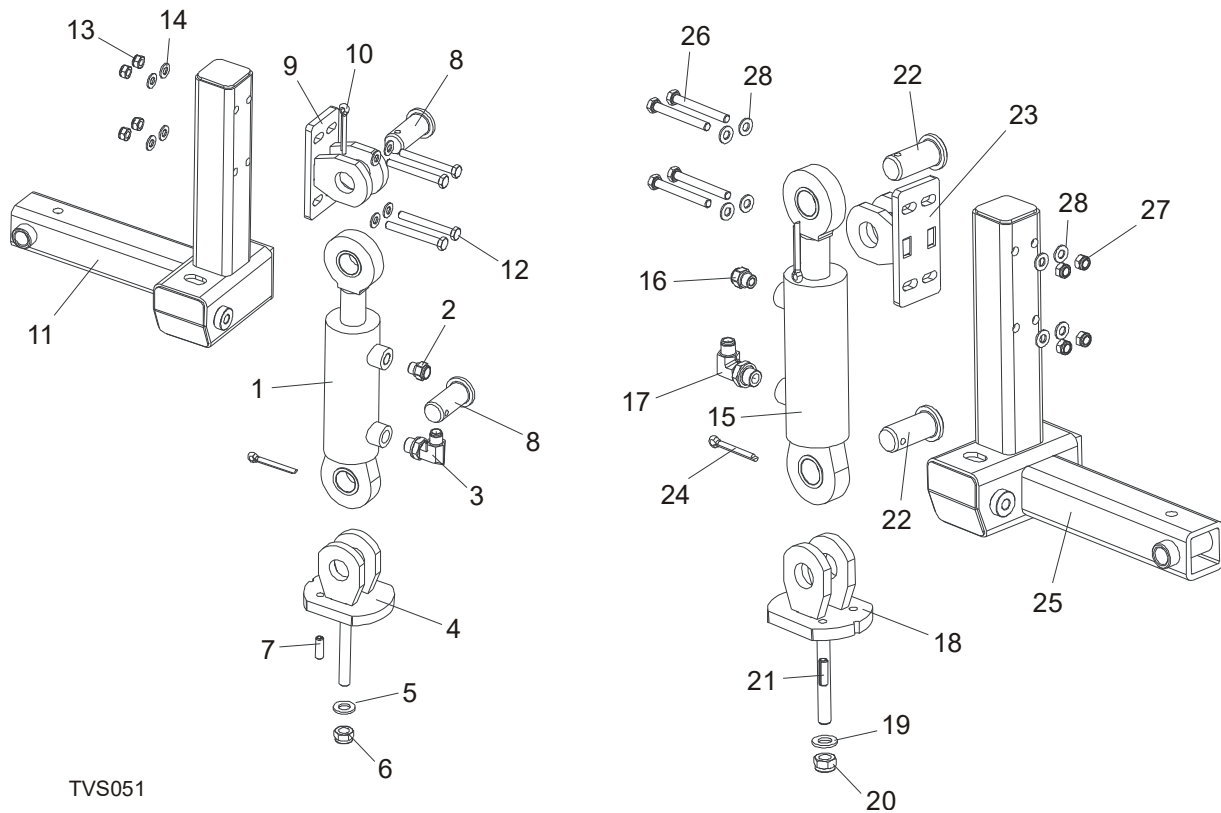

REF	PART #	DESCRIPTION	COMMENTS	QTY.
	504826	HYDRAULIC BLADE TENSIONER, RIGHT SIDE		1
1	504812	Cylinder, SJ2F-16-50/28/70 Hydraulic		1
2	090794	Breather Type 2901-14-17		1
3	096335	Fitting 3/8" BSP-9/16" Jic Elbow		1
4	504822-1	Mounting Bracket, Hydraulic Cylinder, Lower		1

3

Blade Wheels & Tensioner*Blade Tensioner Assembly*

REF	PART #	DESCRIPTION	COMMENTS	QTY.
5	F81056-1	Washer, M12 Flat Zinc		1
6	F81034-2	Nut, M12-8 Hex Nylon Zinc Lock		1
7	F81046-4	Pin, 8x26 Fe/Zn5 Roll		1
8	504824-1	Pin, Zinc-plated		4
9	504819-1	Mounting Bracket, Hydraulic Cylinder, Upper		2
10	F81045-2	Pin S-ZN 6.3x45 Cotter		4
11	504817-1	Arm Weldment, TVS Idle Right Side Blade Wheel		1
12	F81002-71	Bolt M8x70 8.8 Fe/Zn5		8
13	F81032-2	Nut, M8-8-B Hex Nylon Lock Zinc		8
14	F81054-1	Washer, 8.4 Flat Zinc		16
	504815	HYDRAULIC BLADE TENSIONER, LEFT SIDE		1
15	504812	Cylinder, SJ2F-16-50/28/70 Hydraulic		1
16	090794	Breather Type 2901-14-17		1
17	096335	Fitting 3/8" BSP-9/16" Jic Elbow		1
18	504822-1	Mounting Bracket, Hydraulic Cylinder, Lower		1
19	F81056-1	Washer, M12 Flat Zinc		1
20	F81034-2	Nut, M12-8 Hex Nylon Zinc Lock		1
21	F81046-4	Pin, 8x26 Fe/Zn5 Roll		1
22	504824-1	Pin, Zinc-plated		4
23	504819-1	Mounting Bracket, Hydraulic Cylinder, Upper		2
24	F81045-2	Pin S-ZN 6.3x45 Cotter		4
25	504816-1	Arm Weldment, TVS Idle Left Side Blade Wheel		1
26	F81002-71	Bolt M8x70 8.8 Fe/Zn5		8
27	F81032-2	Nut, M8-8-B Hex Nylon Lock Zinc		8
28	F81054-1	Washer, 8.4 Flat Zinc		16

3.4 Blade Tensioner Pump Assembly

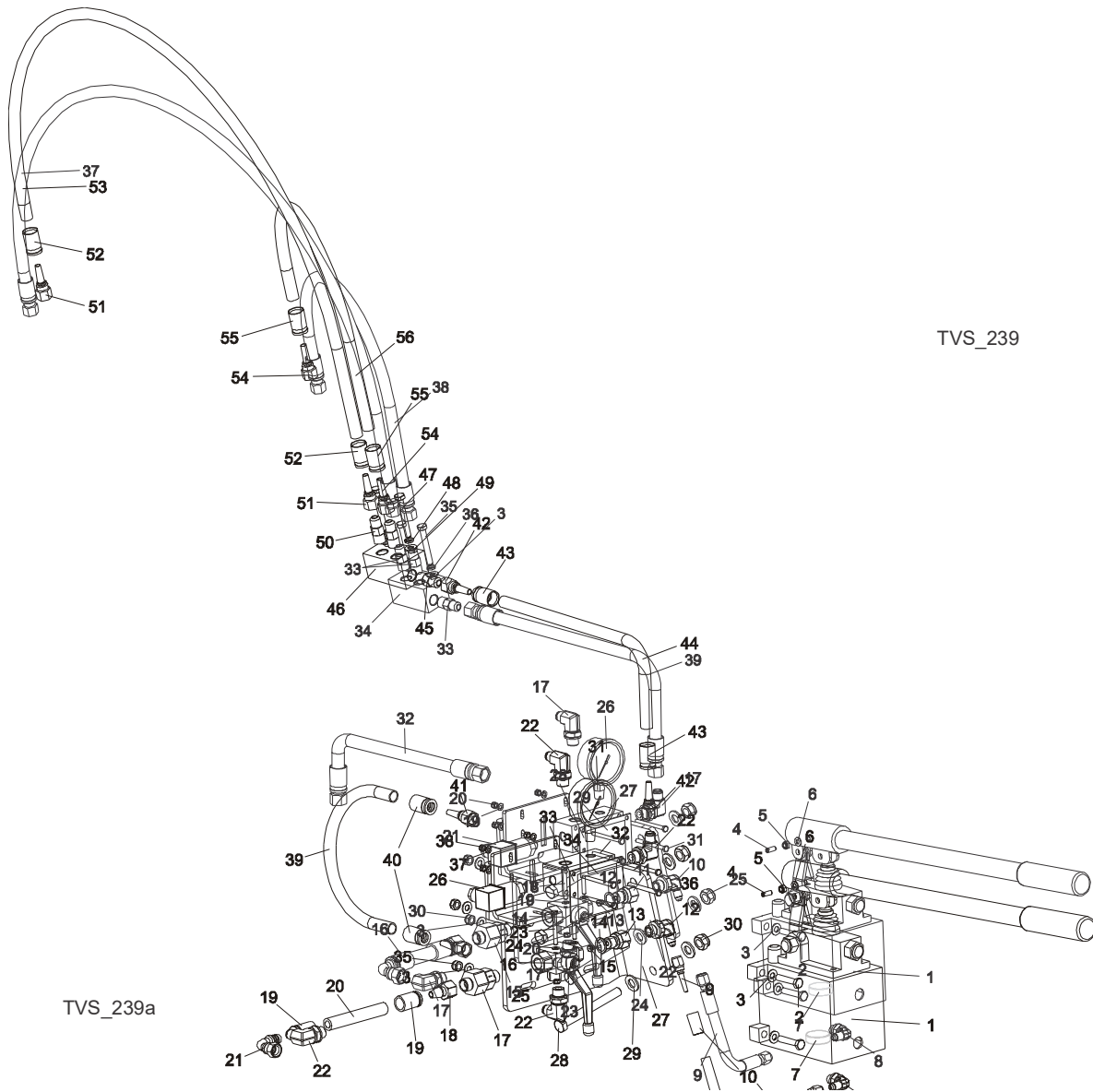

TVS_239

TVS_239a

REF	PART #	DESCRIPTION	COMMENTS	QTY.
	504825	PUMP ASSEMBLY, BLADE TENSIONER		1
1	092789	Pump, PMS12/TNK1 Manual w/1-litre Tank		1
2	F81002-15	Bolt, M8x40-8.8 Hex Head Full Thread Zinc		4
3	F81054-1	Washer, 8.4 Flat Zinc		8
4	096874	Plunger, GN615.3-M6-K Ball Threaded		1

3 Blade Wheels & Tensioner

Blade Tensioner Pump Assembly

REF	PART #	DESCRIPTION	COMMENTS	QTY.
5	F81031-2	Nut, M6-8-B Hex Nylon Zinc Lock		1
6	F81053-1	Washer, 6.4 Flat Zinc		1
7	500022	Magnet, Mw.38x12/n38 Neodymium		1
8	094562	Elbow, Ca-204410-3		1
	505174	Hose, 1/4"(0.19m) Hydraulic		1
9	085902	Nipple JIC 7/16-20		2
10	085903	Crimpsocket, 1/4" Hydraulic Hose		2
11	505174	Hose, 1/4" (0.19m) Hydraulic		1
12	094563	Elbow, CA-204411-3		1
	096850-1	Fitting w/nozzle, G 3/8		1
13	096850-1	Fitting, G3/8 Zinc-plated Special		1
14	F81058-3	Washer, 16 Copper		1
15	091007	Nozzle, D092-O 1mm Dia. Pro-pane&butane		1
16	504803	Valve, RSAP3 VOL2L G3/8" Three-way		1
17	094559	Valve, RHV12LREDA3C Check		1
	504831	Hose, 3/8" w/9/16 M18x1.5 End Fitting		1
18	505309	Fitting, Dn10 D12l M18x1.5 End		1
19	096910	Crimpsocket, Dn-10 3/8" Hydraulic Hose		2
20	504831	Hose, 3/8" w/9/16 ;m18x1.5 End Fitting		1
21	096335	Fitting, 3/8" BSP-9/16" JIC Elbow		1
22	096335	Fitting, 3/8" BSP-9/16" JIC Elbow		3
23	F81000-22	Bolt, M5x45 Din933 A2-70 Stainless Steel		2
24	F81052-1	Washer, 5.3 Flat Zinc		2
25	F81030-2	Nut, M5-8 Din 985 Zinc-plated		2
26	504830	Switch, F4-T-I-M3-16 Bar Pressure		1
27	504836-1	Plate Weldment, Ptd Mounting		1
28	F81004-47	Bolt, M12x110-8.8-b Hex Head Zinc		2
29	F81056-1	Washer, 13 Flat Zinc		4
30	F81034-2	Nut, M12-8 Hex Nylon Zinc Lock		2
31	505176	Gauge, 3000psi Oil Pressure		1
32	504829-1	Block, Zinc-plated Mounting		1
33	505310-1	Plate - Zinc-plated		1
34	505346	Decal, TVS Blade Tensioner Handle Position		1
35	F81032-2	Nut, M8-8-B Hex Nylon Lock Zinc		4
36	F81000-36	Bolt, M5x60 8.8 Hex Head Zinc		4
37	F81052-1	Washer, 5.3 Flat Zinc		4
38	F81030-2	Nut, M5-8 Din 985 Zinc-plated		4
39	504832	Hose, Hydraulic		1
40	085901	Crimpsocket, 3/8" Hydraulic Hose		2
41	085900	Nipple, JIC 9/18-18 Hydr.		2
	505173	Hose, 3/8 "(0.54m) Hydraulic		1
42	085900	Nipple, JIC 9/18-18 Hydr.		2

Blade Wheels & Tensioner
Blade Tensioner Pump Assembly

3

REF	PART #	DESCRIPTION	COMMENTS	QTY.
43	085901	Crimpsocket, 3/8" Hydraulic Hose		2
44	505173	Hose, 3/8 "(0.54m) Hydraulic		1
45	091842	Fitting, G3/8-9/16-18jic Manual Pump		1
46	504828-1	Tee Fitting - Zinc-plated		1
47	F81002-54	Bolt, M8x60-8.8 Hex Head Zinc		2
48	F81054-4	Washer, 8.2 Split Lock Zinc		2
49	F81054-1	Washer, 8.4 Flat Zinc		2
50	091842	Fitting, G3/8-9/16-18jic Manual Pump		2
	504834	Hose, 3/8" 1.2 M Hydraulic		1
51	085900	Nipple, JIC 9/18-18 Hydr.		2
52	085901	Crimpsocket, 3/8" Hydraulic Hose		2
53	504834	Hose, 3/8" 1.2 M Hydraulic		1
	504833	Hose, 3/8:"(0.7m) Hydraulic		1
54	085900	Nipple, JIC 9/18-18 Hydr.		2
55	085901	Crimpsocket, 3/8" Hydraulic Hose		2
56	504833	Hose, 3/8:"(0.7m) Hydraulic		1

4 Saw Head
Middle Throat Screw

SECTION 4 SAW HEAD

4.1 Middle Throat Screw

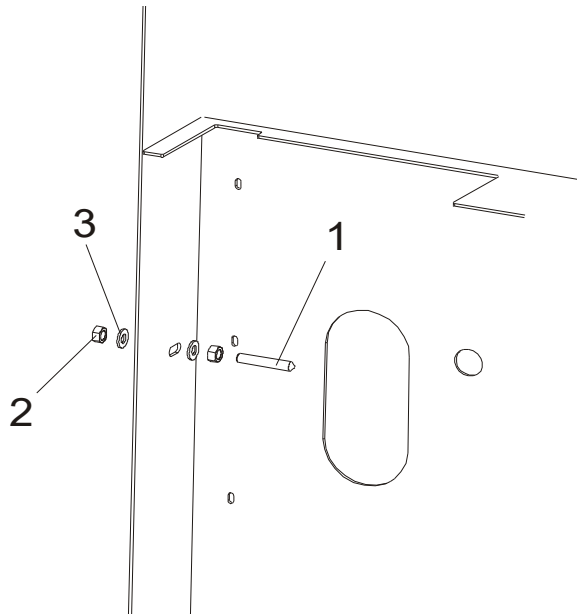

REF	PART #	DESCRIPTION	COMMENTS	QTY.
1	F81003-87	SCREW, M10X60-45H HEX SOCKET SET CONE POINT ZINC		1
2	F81033-3	NUT, M10-8-B HEX ZINC		2
3	F81055-1	WASHER, 10.5 FLAT ZINC		2

4.2 Water Lube Assembly (LMS)

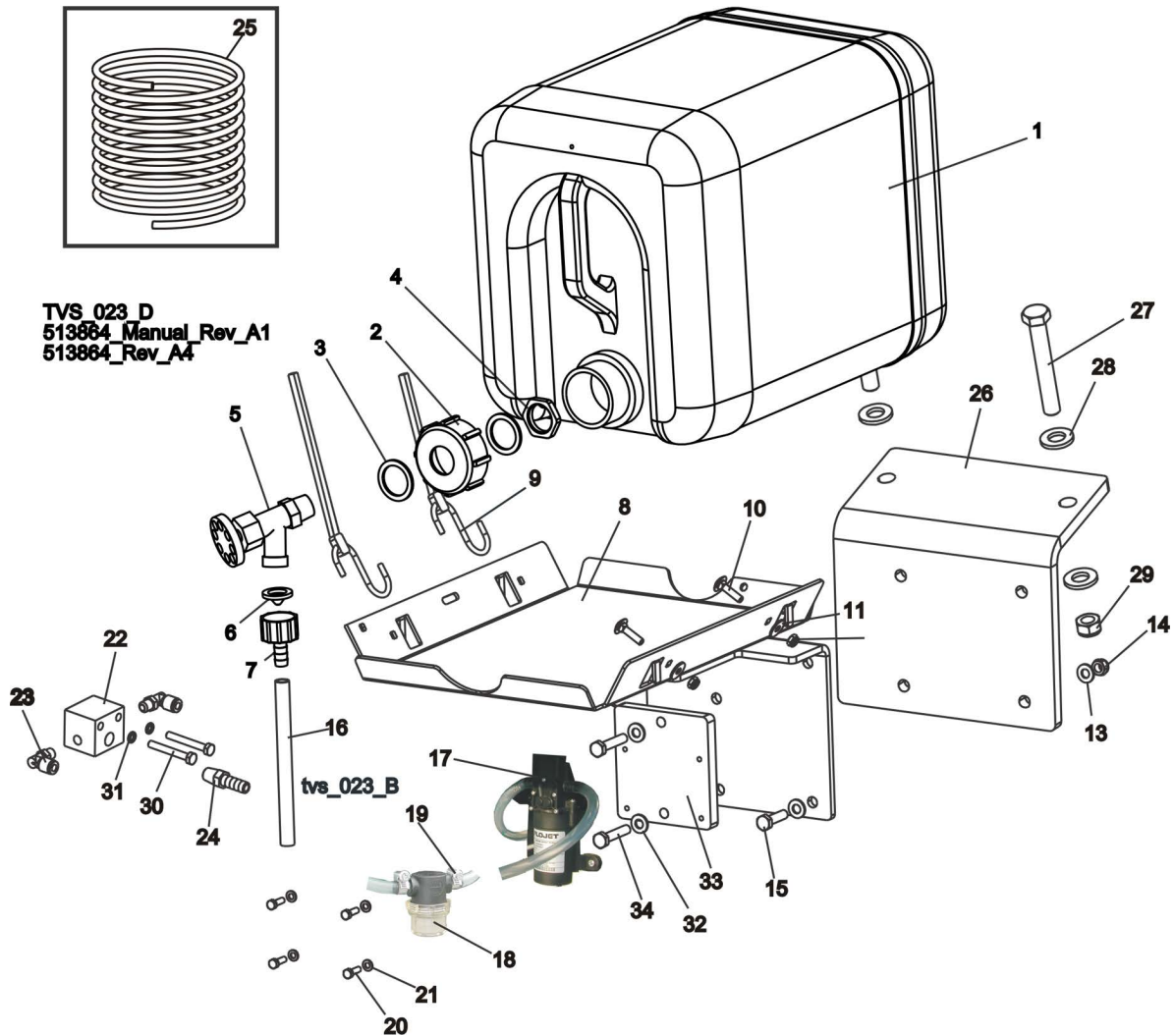

REF	PART #	DESCRIPTION	COMMENTS	QTY.
	091036	BOTTLE KIT, LT20 WATER LUBE		1
	513864	Bottle, Water - Complete		1
	513865	Bottle, Water With Nut		1
1	513866	Bottle, Water		1
2	513867	Nut, Water Bottle		1
3	513869	Seal, 35x26x2 Rubber		2
4	513868	Nut, 3/4 Npt Packing		1
5	133320	Valve, 3/4 NPT Elbow 3/4 Male GHT Outlet		1

4

Saw Head*Water Lube Assembly (LMS)*

REF	PART #	DESCRIPTION	COMMENTS	QTY.
6	016086	Filter, Water Lube		1
7	014113	Reducer, 5/8npt/3/8barb Water Lube		1
8	091033-1	Tray Weldment, LT20 Water Lube		1
9	P11668	Strap, 20" Rubber		2
10	F81001-20	Bolt, M6x25-8.8 Carriage Head Zinc		2
11	F81053-11	Washer, 6.5 Zinc Flat		2
12	F81031-2	Nut, M6-8-B Hex Nylon Zinc Lock		2
13	F81054-1	Washer, 8.4 Flat Zinc		8
14	F81032-2	Nut, M8-8-B Hex Nylon Zinc Lock		4
15	F81002-4	Bolt, M8x20-8.8-b Hex Head Full Thread Zinc		4
16	R01885	Tubing, Water Lube		1
17	510763	PUMP ASSEMBLY, PRESSURE LUBE		1
18	033447	FILTER, PRESSURE LUBE		1
	033441	Screen Kit, Mesh Filter		1
19	F81080-1	CLAMP, PLASTIC HOSE DIA. 8-12MM		2
20	F81000-51	BOLT, M5X16-5.8-HEX HEAD FULL THREAD ZINC		4
21	F81052-1	WASHER, M5 FLAT ZINC		4
22	099213-1	FITTING, TEE TVS LMS		1
23	P09736	FITTING, 1/8" MPT X 1/4 TUBE, ELBOW,SWIVEL		2
24	014685	FITTING, 1/4" NPT-3/8" BARB		1
25	033456	HOSE, 1/4" OD X 6 1/2'		1
26	096178-1	BRACKET, WATER TANK MOUNTING, PTD		1
27	F81004-46	BOLT, M12X80-8.8		2
28	F81056-1	WASHER, M12 FLAT ZINC		4
29	F81034-1	NUT, M12 NYLON HEX ZINC LOCK		2
30	F81001-6	BOLT, M6X45MM HEX HEAD GR5(8.8)F/T ZINC		2
31	F81053-3	WASHER, M6 SPLIT LOCK ZINC		2
32	F81054-1	WASHER, 8.4 FLAT ZINC		2
33	098762-1	RACKET, LMS PUMP ZINC		1
34	F81002-15	BOLT, M8x40-8.8 HEX HEAD FULL THREAD ZINC		2

4.3 Saw Head Decals

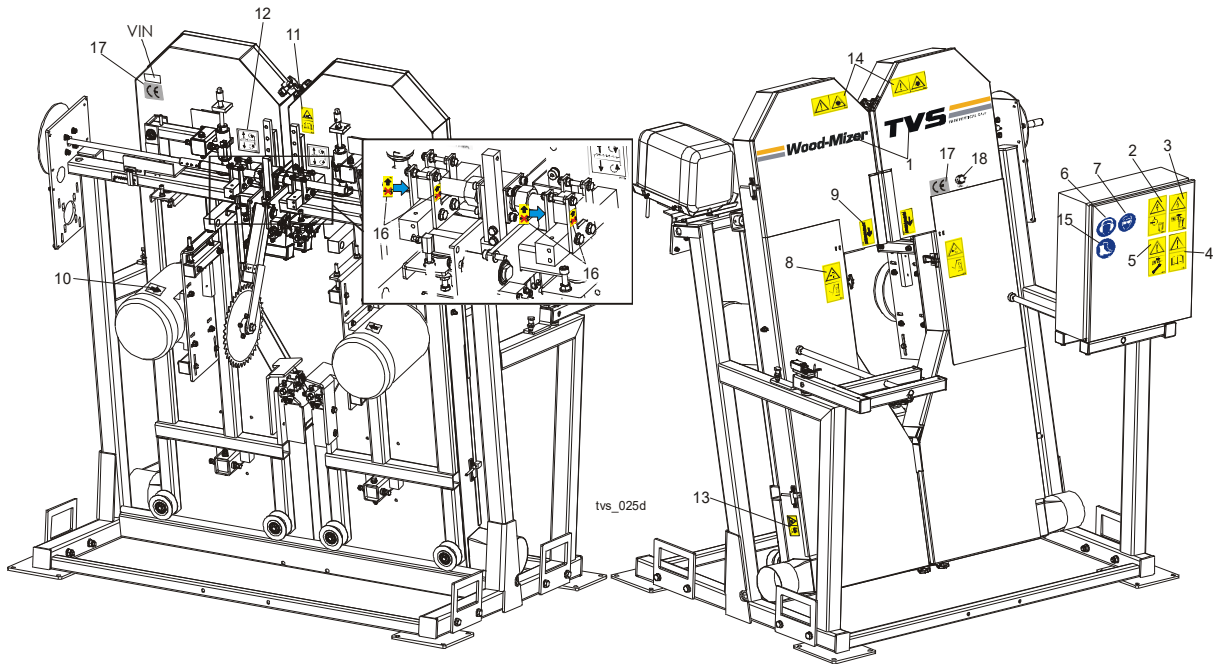

REF	PART #	DESCRIPTION	COMMENTS	QTY.
	099479	Decals Kit, Complete TVS Pictograms		1
1	099422	Decals, TVS Name		1
2	096316	Decal, High Voltage In Electric Box		1
3	096319	Decal, Disconnect Power Supply Befor Opening The Box		1
4	096317	Decal, Read The Manual Before Operating The Machine		1
5	098177	Decal, Disconnect Power Supply Before Servicing		1
6	S12005G	Decal, Ear Warning		1
7	S12004G	Decal, Eye Warning		1
8	099220	Decal, Close Guards Prior To Operatiiong The Machine		2
9	096321	Decal, Blade Movement Direction		2
10	S20097	Decal, Motor Direction		2
11	099223	Decal, Blade Tension - Instruction, Pictogram		1
12	P11789	Decal, Blade Alignment		2
13	099222	Decal, Saw Dust Protection, Pictogram		2
14	099504	Decal, Caution - Laser Beam (Optional)		2
15	501465	Decal, Use Safety Boots Pictogram		1
16	500031	Decal, Don't Adjust Nuts Pictogram		4

4

Saw Head

Blade Housing Cover

REF	PART #	DESCRIPTION	COMMENTS	QTY.
		Tables Decals, See Section 5.6		
17	P85070	DECAL, CE CERTIFIED MACHINE (SMALL)		1
18	099401	DECAL, GOST CERTIFIED MACHINE		1

4.4 Blade Housing Cover

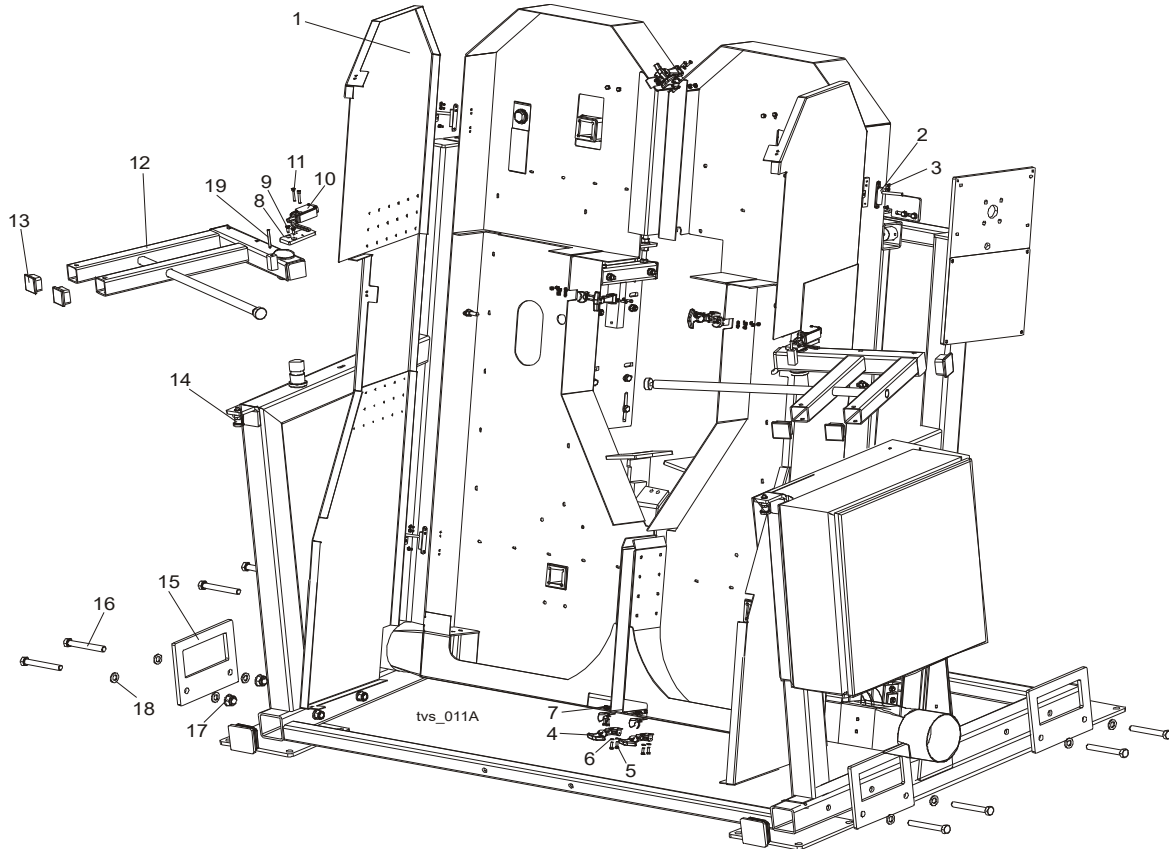

REF	PART #	DESCRIPTION	COMMENTS	QTY.
1	098612-1	COVER, BLADE HOUSING TVS LEFT WLDMT/PTD		1
	096117-1	COVER, BLADE HOUSING TVS RIGHT WLDMT/PTD		1
2	096146	HINGE, COVER		4
3	F81000-15	SCREW, M5X12- 5.8-B SLOTTED COUNTER- SUNK ZINC		8
4	014829	LATCH, FLEXIBLE DRAW		6
5	F81000-51	BOLT, M5X16-5.8-HEX HEAD FULL THREAD ZINC		12
6	F81052-1	WASHER, M5, FLAT ZINC		24
7	F81030-2	NUT, M5-8- DIN 985 ZINC		12

REF	PART #	DESCRIPTION	COMMENTS	QTY.
8	098760-1	FLAT BAR, LIMIT SWITCH MOUNTING ZINC		2
9	F81001-21	SCREW, M6X16, HEX SOCKET HEAD CAP		4
10	088407	SWITCH, GSCA 01S1 LIMIT		2
11	F81000-73	BOLT, M5X35 8.8 HEX SOCKET HEAD CAP ZINC		4
12	098611-1	ARM, CONTROL BOX TVS MOUNTING LEFT WLDMT/PTD		2
	096370-1	ARM, CONTROL BOX TVS MOUNTING RIGHT WLDMT/PTD		2
13	095371	CAP, 50X50(3-5MM THICK) #199274 SHR TUBE END		4
14	090197	PIN, DETENT		2
15	099145-1	PLATE, MOUNTING TVS		4
16	F81006-25	BOLT, M16X120 -8.8- A2E ISO 24014		8
17	F81036-2	NUT, M16 HEX NYLON ZINC LOCK		8
18	F81058-1	WASHER, M16 FLAT ZINC		16
19	F81048-8	PIN, 5M6X50 DIN 6325 HRC60		2

4 Saw Head

Saw Head Width Manual Adjustment Assembly

4.5 Saw Head Width Manual Adjustment Assembly

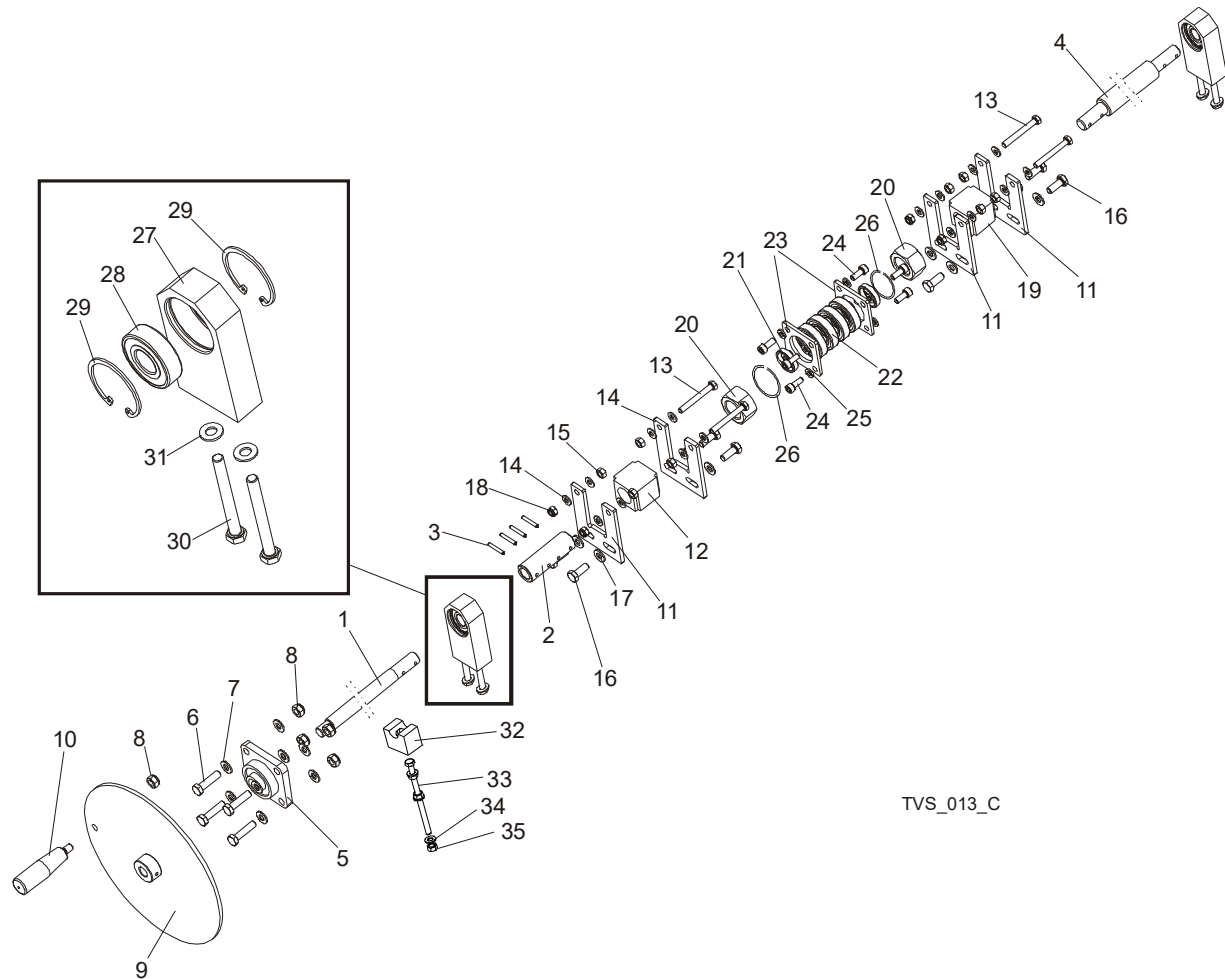

TVS_013_C

REF	PART #	DESCRIPTION	COMMENTS	QTY.
	097664	SCREW, SAW HEAD WIDTH ADJUSTMENT TVS COMPLETE		1
1	096359-1	Rod, Saw Head Width Adjustment		1
2	097665-1	Fastener, Saw Head Width Adjustment Screw		1
3	F81044-21	Pin, 5x30 Roll Zinc		4
4	096154-1	Screw, Saw Head Width Adjustment TVS		1
5	097667	BEARING, UCF 204 W/HOUSING		1
6	F81003-16	BOLT, M10X40-8.8 HEX HEAD FULL THREAD ZINC		4
7	F81055-1	WASHER, M10 FLAT ZINC		8
8	F81033-1	NUT, M10 NYLON HEX ZINC LOCK		5
9	098617-1	PLATE, SAW HEAD ADJUSTMENT SCREW WLDMT/PTD		1

REF	PART #	DESCRIPTION	COMMENTS	QTY.
10	086338	KNOB, PLASTIC CRANK HANDLE		1
11	096861-1	BRACKET, TURNBUCKLE MOUNT ZINC-PLATED		2
12	101439	TURNBUCKLE, M30 TVS		1
13	F81002-9	BOLT, M8X65 8.8 HEX HEAD FULL THREAD ZINC		2
14	F81054-1	WASHER, M8 FLAT ZINC		8
15	F81032-1	NUT, M8 HEXAGON GRADE 5.8 FREE ZINC		4
16	F81003-11	BOLT, M10-1.5X25MM HEX HEAD GR8.8		4
17	F81055-1	WASHER, FLAT M10 ZINC		4
18	F81032-2	NUT, M8 HEXAGON NYLON LOCK ZINC		2
19	101440	TURNBUCKLE, M30 LH TVS		1
20	F81038-3	NUT, M30 HEX ZINC		2
21	096356-1	BUSHING, FI 34 X 38 X 8 SPACER		2
22	096191	BEARING, 6006 2RSR		4
23	096157-1	BRACKET, BEARING MOUNT BLOCK TVS-ZINC		2
24	F81002-30	BOLT, M8X20 8.8-HEX SOCKET HEAD CAP ZINC		8
25	F81054-4	WASHER, 8.2 ZINC		8
26	F81068-1	WASHER, SPLIT LOCK Z30.5		2
	500012	BLOCK, TVS SAW HEAD WIDTH ADJUSTMENT SCREW COMPLETE		2
27	500011-1	Block, TVS Saw Head Width Adjustment Screw		1
28	088447	Bearing, 6204 2RS-CX Rolling		1
29	089653	Ring, W47 Inside Retaining		2
30	F81002-91	Bolt, M8 x 75 8.8 FE/ZN5, PN-M/82101		2
31	F81054-1	Washer, 8.4 Flat Zinc		2
	516336	BOLT ASSEMBLY, HANDLE BRAKING		1
32	517532	Block, Handle Braking Bolt Assembly		1
33	F81002-72	Bolt M8x130 8.8 Hex Head Full Thread Zinc		1
34	F81054-1	Washer, 8.4 Flat,zinc		3
35	F81032-1	Nut, M8-8-b Hex Zinc		3

4 Saw Head

Saw Head Width Automatic Adjustment Assembly (Optional)

4.6 Saw Head Width Automatic Adjustment Assembly (Optional)

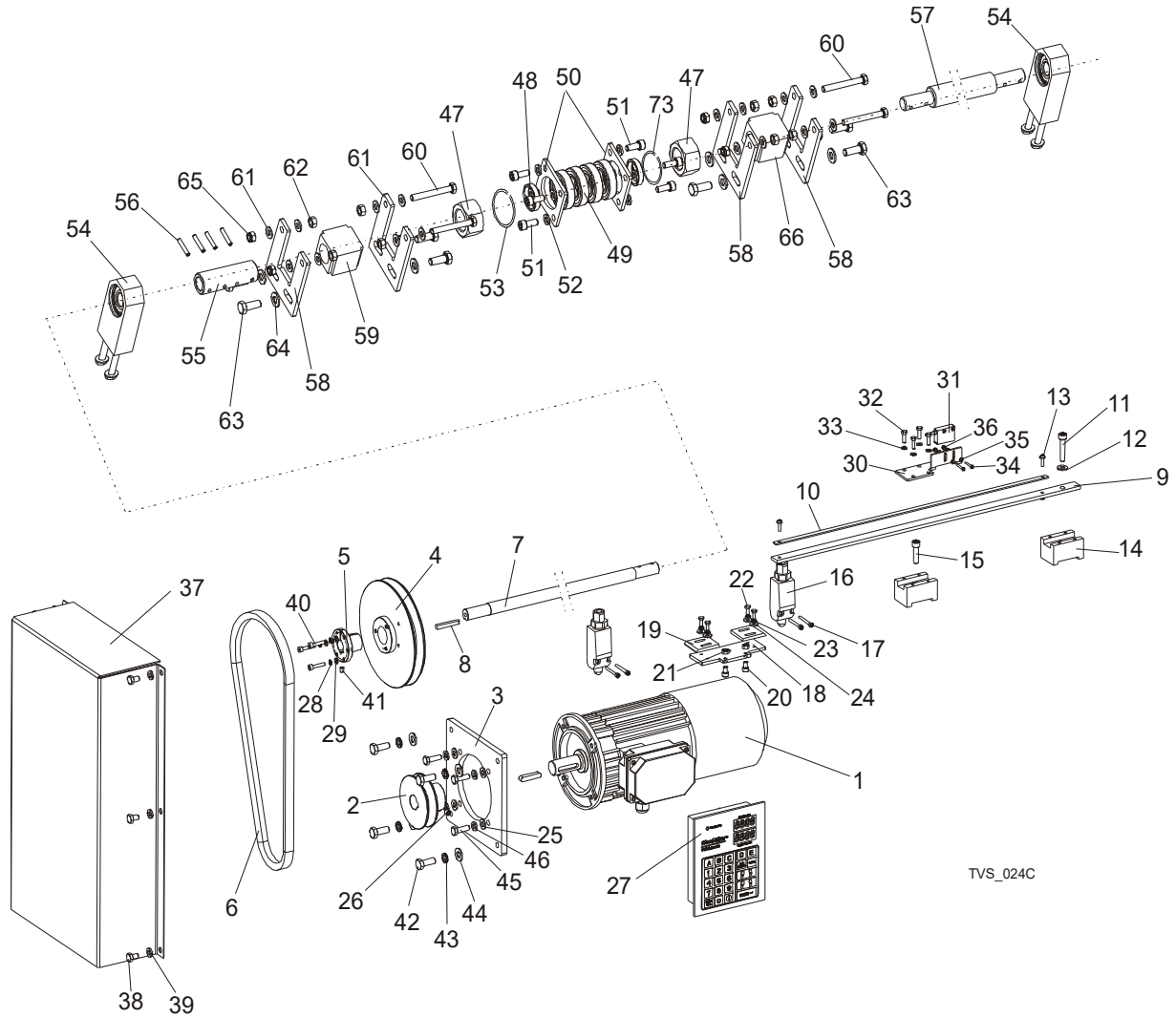

REF	PART #	DESCRIPTION	COMMENTS	QTY.
	099185	SCREW, SAW HEAD WIDTH ADJUSTMENT TVS COMPLETE		1
	099185-4C	SCREW, CUTTING WIDTH SETTING - COMPLETE, TVS USA (UL)		1
1	098891	Motor, SKH90-8L1 HPS 0.55KW, 750RPM, 400V (Europe)		1
	099515-UL	Motor, SKH90-8L1 0.55KW, 750RPM, 400V (TVS-USA)		1
2	098116-1	Sheave, TVS Saw Head Width Adjustment		1
3	099181-1	Bracket, Motor		1
4	098117-1	Sheave, Type B $\Phi 180 \times \phi 30$		1
5	099317	Bushing, Taper		1

Saw Head

Saw Head Width Automatic Adjustment Assembly (Optional)

4

REF	PART #	DESCRIPTION	COMMENTS	QTY.
6	099320	Belt, TVS		1
7	099180-1	Rod, Saw Head Width Adjustment		1
8	089229	Key, AB 6 x 6 x 45 Parallel		1
	502924	Guard, TVS W/magnetic Strip		1
9	502694	Guard, TVS Magnetic Strip	Available in assemblies only.	1
10	096014-1	Strip, MB320 (1m) Magnetic		1
11	F81002-29	Screw, M8 x 40 -8.8- hex socked head cap zinc		1
12	F81054-1	Washer, M8 Flat		1
13	F81051-2	Washer, 4.3 Flat Zinc		1
14	502923	Mounting Block With Magnetic Strip		2
15	F81002-31	Screw, M8 x 30 -8.8 Hex Socked Head Cap Zinc		1
16	089816	Limit Switch		2
17	F81000-8	Bolt, M3 x 20-5.8-a-pan Head		4
	098992	Limit Switch Assembly		1
18	098988-1	Plate, Limit Switch Mount		1
19	098989	Bar, Limit Switch Flat		2
20	F81001-12	Screw, M6 x 10 -8.8- Hex Socked Head Cap Zinc		2
21	F81031-1	Nut, M6 Hexagon Free Grade 5(8.8) Zinc		2
22	F81000-5	Bolt, M5 X 12-5.8-hex Head Full Thread Zinc		4
23	F81052-2	Washer, M5 Split Lock		4
24	F81052-3	Washer, 5.5 Flat Zinc Special		4
25	F81054-1	Washer, M8 Flat Zinc		4
26	F81014-1	Screw, Set M8 x 8-33H FE/ZN Hex Sckt Head		1
27	503467	Controller, TBS01		1
28	F81052-2	Washer, M5 Split Lock		3
29	F81052-1	Washer, M5, Flat Zinc		3
30	502922-1	Bracket, Sensor		1
31	096014	Sensor Assembly, MSK-320		1
32	F81000-20	Bolt, M5x16 -8.8- Fhex Head Full Thread Zinc		4
33	F81052-1	Washer, M5, Flat Zinc		4
34	F81000-8	Screw, M3 x 20-5.8-a-pan Head		2
35	F81050-2	Washer, 3.2 Flat Zinc		4
36	F81028-2	Nut, M3-6- Hex Nylon Zinc Lock		2
37	098121-1	Cover, Saw Head Width Adjustment Tvs		1
38	F81002-6	Bolt, M8 x 12mm, Hex Head Full Thread,gr8.8,zinc		6
39	F81054-4	Washer, 8.2 Split Lock		6
40	F81000-7	Screw, M5 x 25-8.8-hex Socked Head Cap Zinc		1
41	F81013-1	Screw, M6 x 8 Pan Head		1
42	F81003-11	Bolt, M10-1.5 x 25mm Hex Head Grade 8.8		4
43	F81055-2	Washer, M10 Split Lock Zinc		4

4

Saw Head*Saw Head Width Automatic Adjustment Assembly (Optional)*

REF	PART #	DESCRIPTION	COMMENTS	QTY.
44	F81055-1	Washer, Flat M10, Zinc		4
45	F81002-5	Bolt, M8 x 25mm Hex Head Grade 5.8 Zinc		4
46	F81054-4	Washer, 8.2 Split Lock Zinc		4
47	F81038-3	NUT, M30 HEX ZINC		2
48	096356-1	BUSHING, FI 34 X 38 X 8 SPACER		2
49	096191	BEARING, 6006 2RSR		4
50	096157-1	BRACKET, BEARING MOUNT BLOCK TVS-ZINC		2
51	F81002-30	BOLT, M8 X 20 -8.8-HEX SOCKET HEAD CAP ZINC		8
52	F81054-4	WASHER, 8.2 ZINC		8
53	F81068-1	WASHER, SPLIT LOCK Z30.5		2
54	500012	BLOCK, TVS SAW HEAD WIDTH ADJUSTMENT SCREW COMPLETE		2
55	097665-1	FASTENER, SAW HEAD WIDTH ADJUSTMENT SCREW		1
56	F81044-21	PIN, 5 X 30 ROLL ZINC		4
57	096154-1	SCREW, SAW HEAD WIDTH ADJUSTMENT TVS		1
58	096861-1	BRACKET, TURNBUCKLE MOUNT ZINC-PLATED		2
59	101439	TURNBUCKLE, M30 TVS		1
60	F81002-9	BOLT, M8 X 65 8.8 HEX HEAD FULL THREAD ZINC		2
61	F81054-1	WASHER, M8 FLAT ZINC		8
62	F81032-1	NUT, M8 HEXAGON, GRADE 5.8 FREE ZINC		4
63	F81003-11	BOLT, M10-1.5 X 25MM HH GR8.8		4
64	F81055-1	WASHER, FLAT M10 ZINC		4
65	F81032-2	NUT, M8 HEXAGON NYLON LOCK ZINC		2
66	101440	TURNBUCKLE - M30 LH TVS		1

4.7 Saw Head Width Indicator

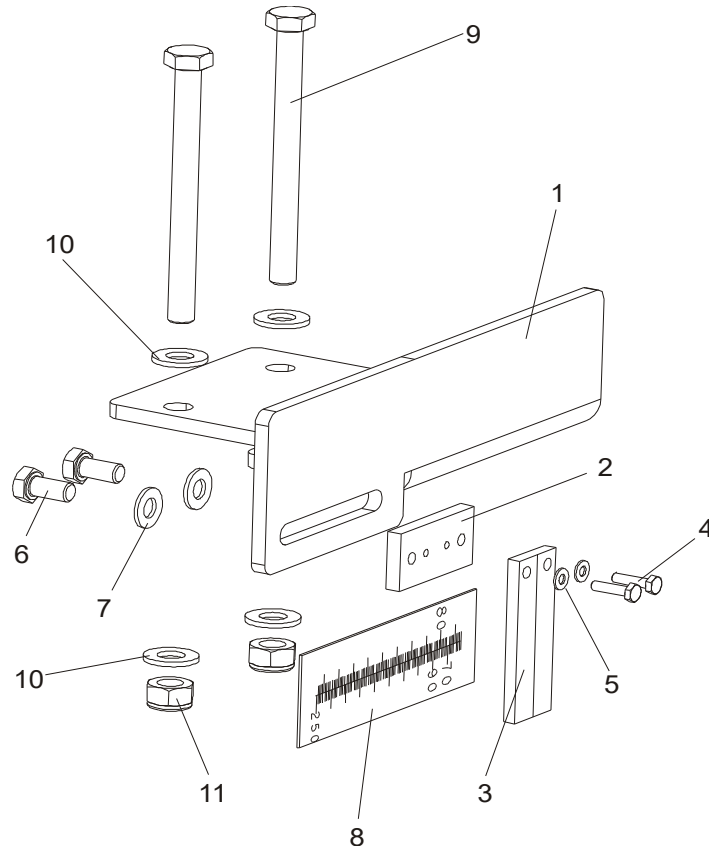

REF	PART #	DESCRIPTION	COMMENTS	QTY.
	098756	SCALE INDICATOR, TVS COMPLETE		1
1	098622-1	Bracket, Scale Indicator TVS		1
2	094438-1	Block, Blade Width Indicator Reducer		1
3	094821	Indicator, Blade Width Scale		1
4	F81011-6	Bolt, M4x16 5.8 Hex Head Full Thread Zinc		2
5	F81051-2	Washer, 4.3 Flat Zinc		2
6	F81002-20	Bolt, M8x16 -8.8-b-hex Head Full Thread Zinc		2
7	F81054-1	Washer, M8 Flat Zinc		2
8	098619	Scale, TVS Metric		1
	502669	Scale, TVS Inch		1
9	F81003-43	Bolt, M10x110 8.8 Hex Head Zinc		2
10	F81055-1	Washer, M10 Flat Zinc		4
11	F81033-1	Nut, M10 Nylon Hex Zinc Lock		2

4 Saw Head

Saw Head Slide Brackets

4.8 Saw Head Slide Brackets

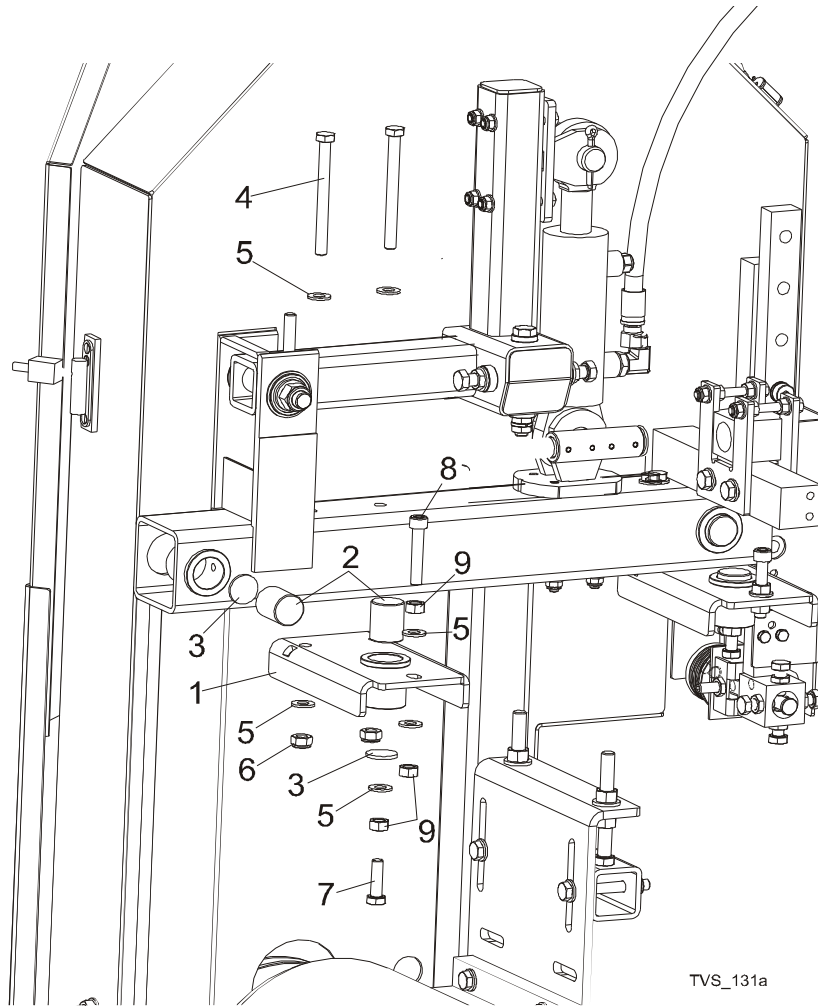

REF	PART #	DESCRIPTION	COMMENTS	QTY.
1	096838-1	BRACKET, SLIDE LOWER TVS		2
2	096128	ROD, SLIDE TVS		4
3	096129-1	WASHER, BUSHING SLIDE ZINC TVS		4
4	F81003-43	BOLT, M10X110 8.8 ZINC		4
5	F81055-1	WASHER, 10.5 FLAT ZINC		9
6	F81033-1	NUT, M10-8-B NYLON HEX ZINC LOCK		4
7	F81003-17	BOLT, M10X35-8.8 HEX HEAD FULL THREAD ZINC		2
8	F81003-55	SCREW, M10X55-8.8 HEX SOCKET HEAD CAP		2
9	F81033-3	NUT, M10-8-B-FE		6

4.9 Hold-Down Roller

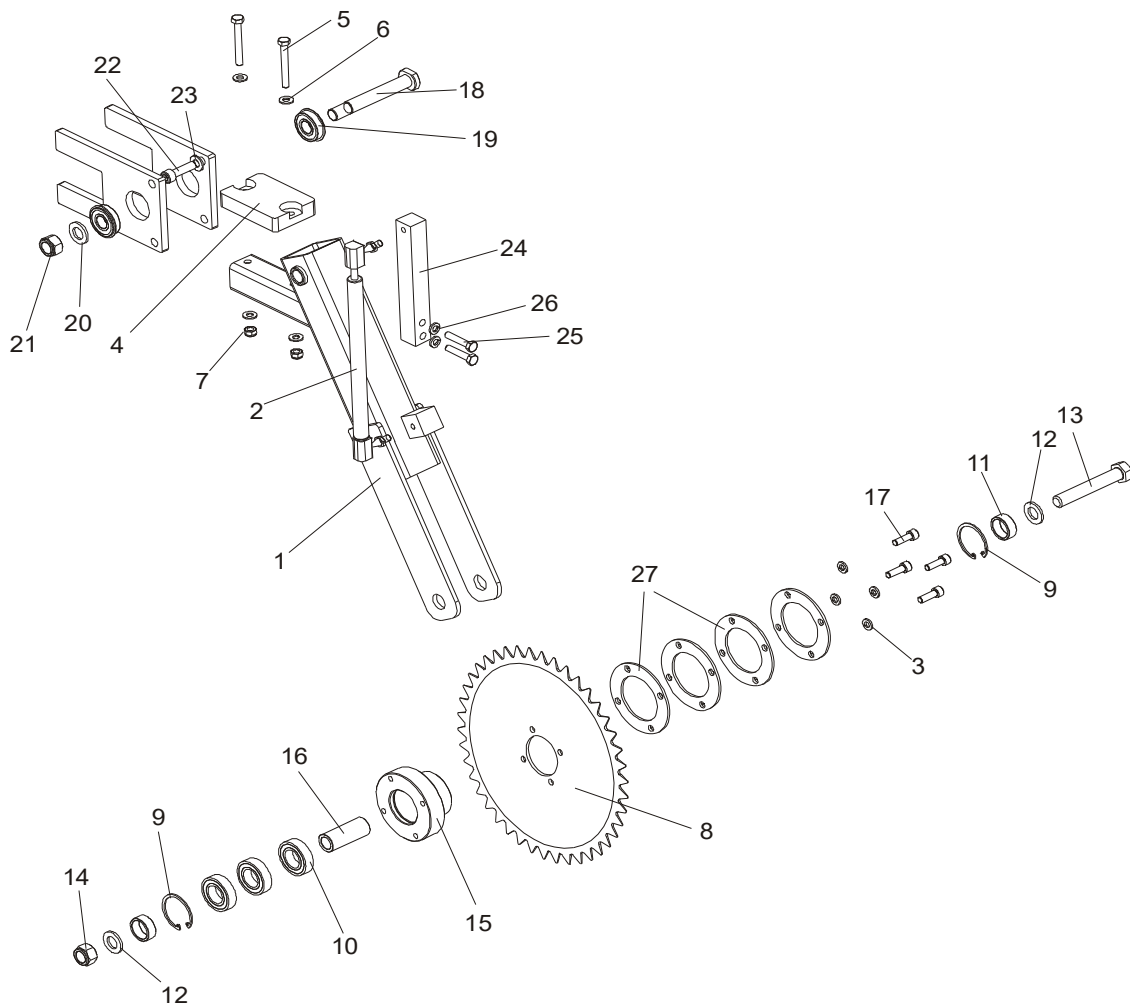

REF	PART #	DESCRIPTION	COMMENTS	QTY.
	097954	ROLLER, HOLD-DOWN TVS		1
1	097953-1	Arm, Lower Hold-down Wldmt/ptd		1
2	089212	Spring, 340N Gas Complete		1
3	F81054-4	Washer, 8.2 Split Lock Zinc		4
4	094969	Bumper, Grene 70 3201 0010 Shr Rubber		1
5	F81002-3	Bolt, M8 x 65mm Hex Head Grade 5.8 Zinc		2
6	F81054-1	Washer, M8 Flat Zinc		4
7	F81032-2	Nut, M8 Hex Nylon Lock Zinc		2
8	096352-1	Wheel, Log Hold-down Tvs		1
9	089653	Ring, W47 Spring Retaining		2
10	089652	Bearing, 6005 2RS CX		3

4

Saw Head*Hold-Down Roller*

REF	PART #	DESCRIPTION	COMMENTS	QTY.
11	097942-1	Bushing, Fi 25.5 X 32x12 Spacer Zinc		2
12	F81058-1	Washer, M16 Flat Zinc		2
13	F81006-2	Bolt, M16x100mm Hex Head Full Thrd Zinc		1
14	F81036-2	Nut, M16 Hex Nylon Zinc Lock		1
15	096351-1	Shaft, Log Hold-down Wheel Zinc-plated		1
16	098610-1	Bushing, Fi 25x16,5x60 Spacer Zinc		1
17	F81002-21	Bolt, M8x25 -8.8- Hex Socket Head Cap Zinc		4
18	086404	PIN, IDLER ARM MOUNT		1
19	086395	BEARING W/SNAP RING 6203-2RS		2
20	F81058-1	WASHER, M16 FLAT ZINC		1
21	F81036-2	NUT, M16 HEX NYLON ZINC LOCK		1
22	F81003-56	BOLT, M10X35 HEX SOCKET HEAD CAP ZINC		1
23	F81055-1	WASHER, M10 FLAT ZINC		1
24	096160-1	BRACKET, GAS SPRING ZINC		1
25	F81002-15	BOLT, 8MM X 1.25 X 40MM HH ZINC		2
26	F81054-4	WASHER, 8.2 SPLIT LOCK ZINC		2
27	099530-1	SPACER		4

4.10 Blade Drive Motor

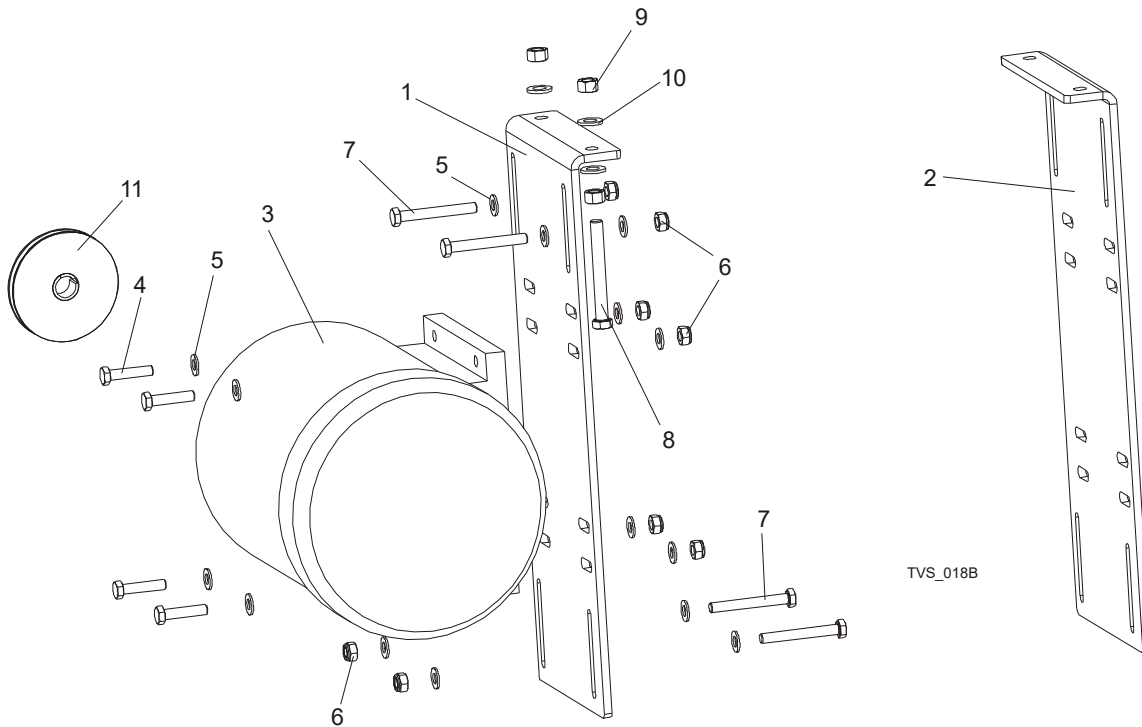

REF	PART #	DESCRIPTION	COMMENTS	QTY.
1	099398-1	PLATE, MOTOR MOUNT RIGHT - PTD		1
2	099397-1	PLATE, MOTOR MOUNT LEFT - PTD		1
3	P85186-UL	MOTOR, 12KW (17HP) 460V ELECTRIC		2
4	F81003-3	BOLT, M10X45MM HEX HEAD FULL THRD ZINC		8
5	F81055-1	WASHER, M10 FLAT ZINC		32
6	F81033-1	NUT, M10 NYLON HEX ZINC LOCK		16
7	F81003-50	BOLT, M10X80 -8.8- HEX ZINC		8
8	F81004-45	BOLT, M12X100 8.8 HEX HEAD FULL THREAD ZINC		4
9	F81034-1	NUT, M12 HEX GRADE 5.8 ZINC		4
10	F81056-1	WASHER, M12 FLAT ZINC		8
11	500571	PULLEY, SPB 140X1/38 (F02325+T31079)	Standard Equipment. Blade Linear Velocity v=67 ft./sec. (20.5 m/s).	2
	500575	PULLEY, SPB 170X1/38 (F01794+T31079)	Blade Linear Velocity v=82 ft./sec. (25 m/s).	2
	099601	PULLEY, SPB190/1 W/2012/38 TAPER SPLIT BUSHING	Blade Linear Velocity v=92 ft./sec. (28 m/s).	2

4

Saw Head

Saw Head Support Rollers

REF	PART #	DESCRIPTION	COMMENTS	QTY.
	501556	PULLEY, SPB125X1/FI38 F02319+T31079 TAPER SPLIT BUSHING	Blade Linear Velocity v=75 ft./sec. (23 m/s).	2
	099503	PULLEY, 150/ FI42 F02329+T31081 (TVS-USA)		1

4.11 Saw Head Support Rollers

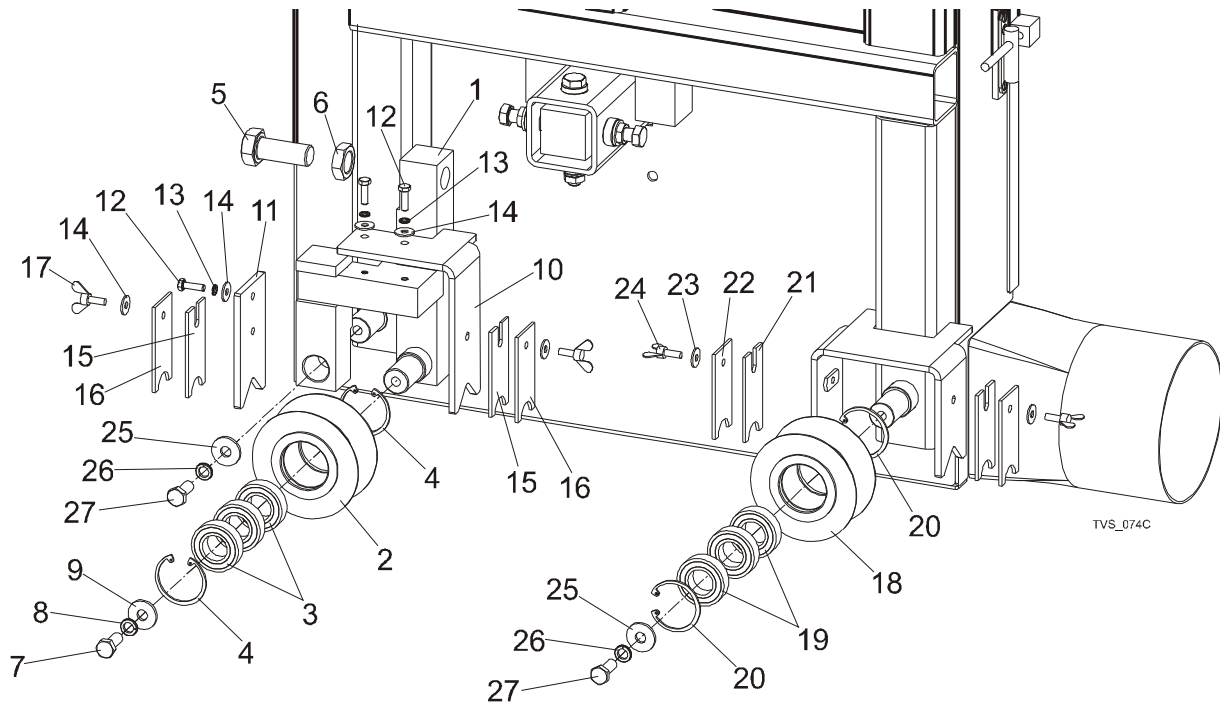

REF	PART #	DESCRIPTION	COMMENTS	QTY.
	100179	ROLLER, TVS SAW HEAD ADJUST SUPPORT COMPLETE		2
1	100177-1	Support, TVS Saw Head Roller		1
	096835	Roller, TVS Saw Head Support, Complete		1
2	096834-1	Roller, TVS Saw Head Support, Ptd		1
3	089652	Bearing, 6005 2RS CX		3
4	089653	Ring, W47 Spring Retaining		2
5	F81007-2	Bolt, M10x1.5x50-8.8-B Zinc-plated		1
6	F81037-7	Nut, M20x1.5 Zinc-plated Thin		1
7	F81003-31	Bolt, M10 x 25 8.8 FE/ZN5, PN-M/82105		1
8	F81055-2	Washer, 10.2 Split Lock Zinc		1
9	F81055-6	Washer, 10.5 Zinc Flat Special		1
10	101092-1	Support, Wiper Right		1
11	101093-1	Support, Wiper Left		1

REF	PART #	DESCRIPTION	COMMENTS	QTY.
12	F81001-2	Bolt, M6x20-8.8 Hex Head Full Thread Zinc		3
13	F81053-3	Washer, Z6.1 Split Lock Zinc		3
14	F81053-11	Washer, 6.5 Flat Zinc		5
15	101090	Wiper, Top Rail		2
16	088559-1	Plate, Track Wiper Ptd		2
17	F81001-16	Bolt, M6x16 BN276		2
	096835	ROLLER, TVS SAW HEAD SUPPORT COMPLETE		1
18	096834-1	Roller, TVS Saw Head Support Ptd		1
19	089652	Bearing, 6005 2RS CX		3
20	089653	Ring, W47 Spring Retaining		2
21	F81053-11	WASHER, 6.5 FLAT ZINC		5
22	101090	WIPER, TOP RAIL		2
23	088559-1	PLATE, TRACK WIPER PTD		2
24	F81001-16	BOLT, M6X16 BN276		2
25	F81003-31	BOLT, M10 X 25 8.8 FE/ZN5 PN-M/82105		2
26	F81055-2	WASHER, 10.2 SPLIT LOCK ZINC		2
27	F81055-6	WASHER, 10.5 ZINC FLAT SPECIAL		2

4.12 Main Control Assembly

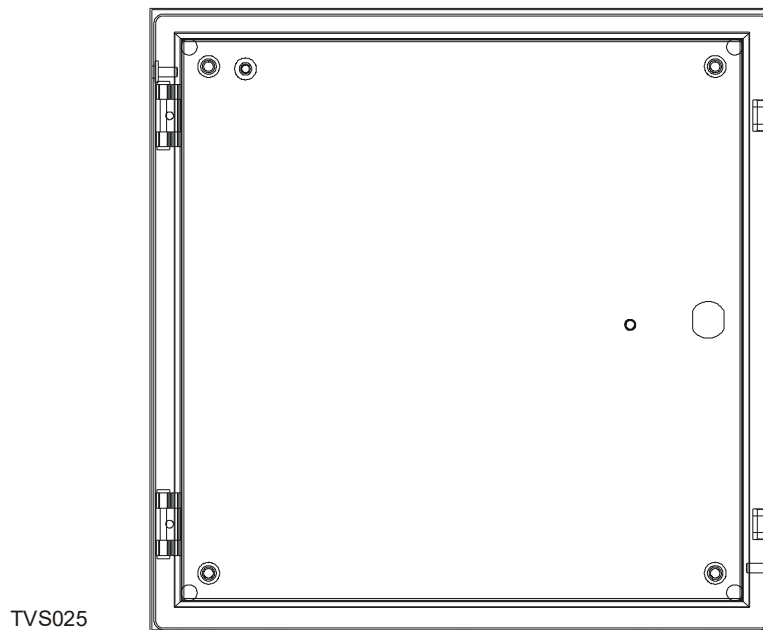

REF	PART #	DESCRIPTION	COMMENTS	QTY.
	053722-4	CONTROL ASSEMBLY, TVSEC15U MAIN (U.S. ONLY)		1

4 Saw Head

Operator Control Box Assembly

REF	PART #	DESCRIPTION	COMMENTS	QTY.
	053724	Enclosure, TVS Control		1
	062457	Plate, Control Box Mount		1
	062458	Plate, Control Box Saddle		1
	053723-4	Insert Assembly, TVSEC15U Main		1
	S20061	Decal, Electrical Hazard Danger		1
	069748	Harness Assembly, TVS Blade Motor Left		1
	069749	Harness Assembly, TVS Blade Motor Right		1
		<i>See Form #2049 TVS Electrical Information for more electrical information and replacement parts</i>		

4.13 Operator Control Box Assembly

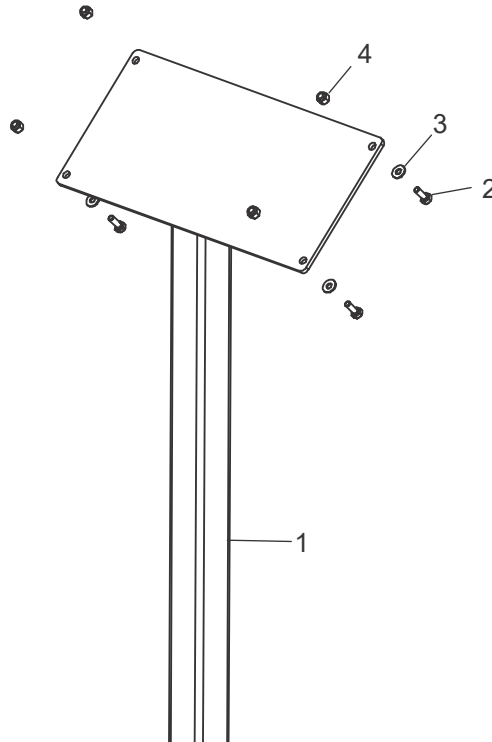

REF	PART #	DESCRIPTION	COMMENTS	QTY.
	069762	OPERATOR ASSEMBLY, TVS (U.S. ONLY)		1
1	039336	Stand Weldment, Edger Control		1
	053728-2	Control Assembly, TVSEC15U Operator		1
	069746-1	Enclosure, TVS Operator		1
	078312	Decal, TVS Operator Control		1
	078313	Plate, TVS Operator Stwx Blank Front		1
	078314	Plate, TVS Operator Stwx Blank Back		1

REF	PART #	DESCRIPTION	COMMENTS	QTY.
	078315	Gasket, TVS Operator Stwx Blank		1
		<i>See Form #2049 TVS Electrical Information</i> for more electrical information and replacement parts		
2	F05005-1	Bolt, 1/4-20 x 3/4" Full Thread HHC		4
3	F05011-11	Washer, 1/4" SAE Flat		8
4	F05010-69	Nut, 1/4-20 Nylock		4

4.14 Laser Assembly (Optional)

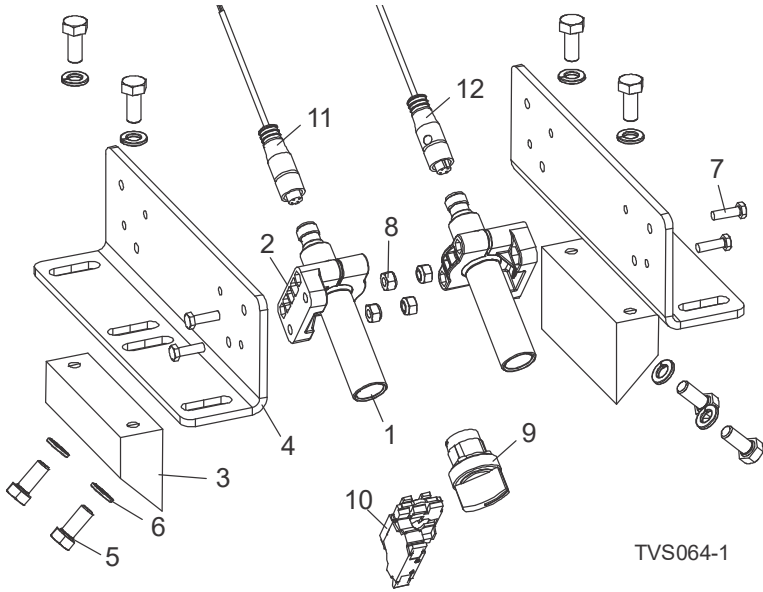

TVS064-1

REF	PART #	DESCRIPTION	COMMENTS	QTY.
	TVSULAS-CI	TVS LASER ASSEMBLY, COMPLETE (CUSTOMER INSTALLED)		1
	TVSULAS-MI	TVS LASER ASSEMBLY, COMPLETE (MANUFACTURER INSTALLED)		1
1	069771-3	Control Assembly, TVSEC15U Lasers		1
2	069855	Laser, 5mW 532nm 90 Deg Line Z-Laser		2
3	069856	Bracket, M18 Swivel		2
4	062455	Block, Laser Mount		2
5	062456	Plate, Laser Mount		2
6	F05006-5	Bolt, 5/16-18 x 3/4" HHC		8
7	F05011-13	Washer, 5/16" Split Lock		8

4 Saw Head

Laser Assembly (Optional)

REF	PART #	DESCRIPTION	COMMENTS	QTY.
8	F05004-18	Screw, 10-24 x 5/8" Unsl Indent HH Machine		4
9	F05010-160	Nut, 10-24 Hex Nylock		4
10	068943	Switch, 2Pos Maintained ZB5		1
11	068952	Collar, Mount 1NO ZB5		1
12	078387	Cable Assembly, TVSU Laser Left		1
13	078388	Cable Assembly, TVS Laser Right		1
14	M1736	Instruction Sheet, TVS Networks Installation		1

SECTION 5 INFEED & OUTFEED TABLES

5.1 TVS Infeed

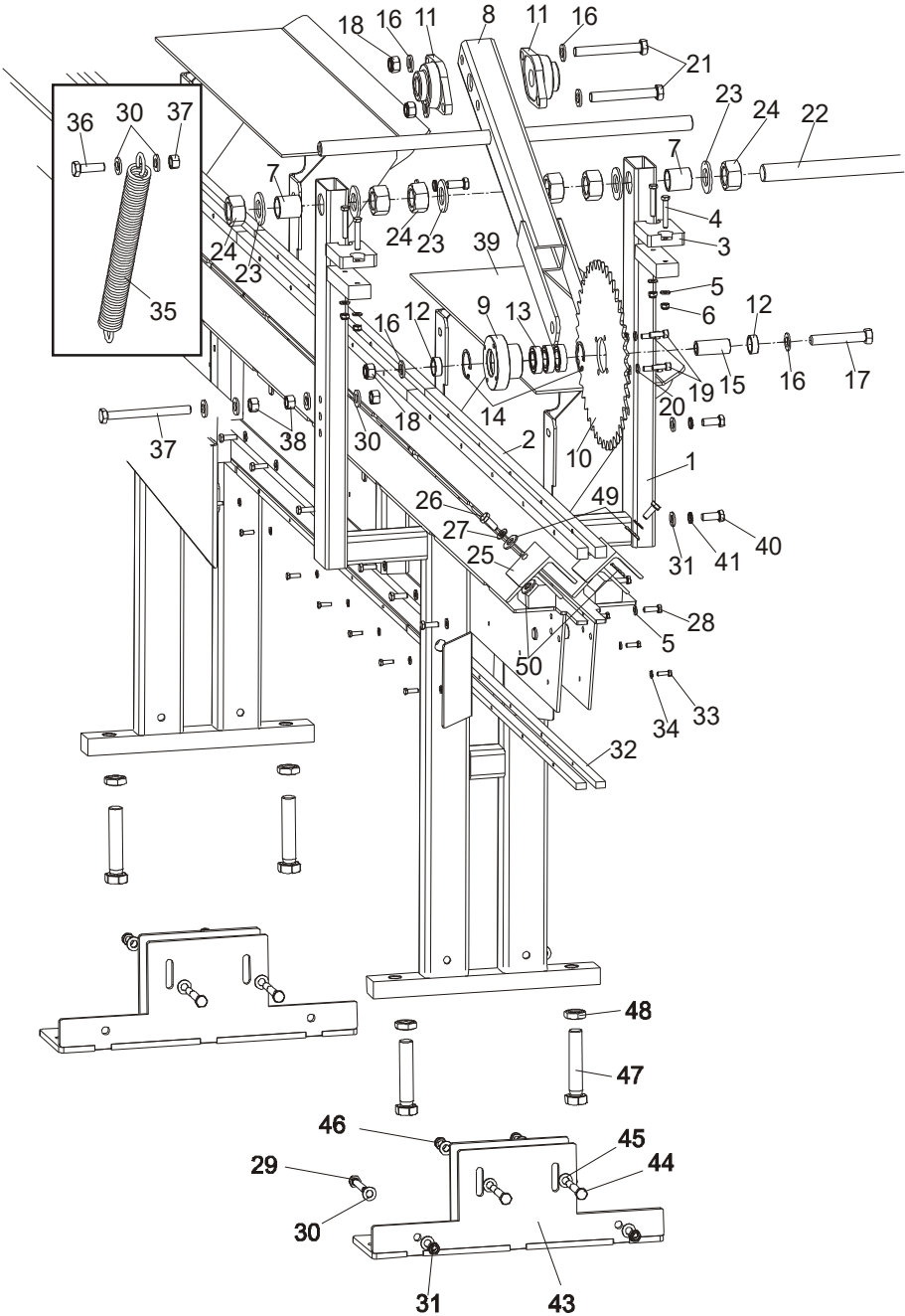

5 Infeed & Outfeed Tables

TVS Infeed

REF	PART #	DESCRIPTION	COMMENTS	QTY.
	098946	INFEED, TVSIV2.4I		1
	098947	INFEED, TVSIV2.4M		1
	097641	TVS Infeed, Short Complete		1
1	097643-1	TVS Infeed, Short	Available in assemblies only.	1
2	098652-1	Bar, Chain Outer Slide		2
	096199-1	Bar, Chain Slide Zinc		4
3	094969	Bumper, Grene 70 3201 0010 Shr Rubber		2
4	F81002-19	Bolt, M8x50-8.8-hex Head Full Thread Zinc		4
5	F81054-1	Washer, M8 Flat Zinc		42
6	F81032-2	Nut, M8 Hex Nylon Lock Zinc		4
7	096355-1	Bushing, Spacer Zinc		2
	096350	Arm, Complete Roller Hold-Down		1
8	096348-1	Arm, Roller Hold-Down Wldmt/ptd		1
9	096351-1	Shaft, Log Hold-Down Wheel Zinc-plated		1
10	096352-1	Wheel, Log Hold-down Zinc-plated		1
11	090851	Bearing, UCFL 206 CX		2
12	097942-1	Bushing, Fi 25,5 X 32x12- Spacer Zinc		2
13	089652	Bearing, 6005 2RS CX		3
14	089653	Ring, W47 Spring Retaining		2
15	098610-1	Bushing, Fi 25x16.5x60 -spacer Zinc		1
16	F81058-1	Washer, M16 Flat Zinc		6
17	F81006-2	Bolt, M16x100mm Hex Head Full Thrd Zinc		1
18	F81036-2	Nut, M16 Hex Nylon Zinc Lock		3
19	F81002-21	Bolt, M8x25 -8.8- Hex Socket Head Cap		4
20	F81054-4	Washer, 8.2 Split Lock Zinc		4
21	F81006-25	Bolt, M16x120 -8.8- A2E ISO 24014		2
22	096344-1	Rod, M30 (690) Hold-Down Arm Threaded Zinc		1
23	F81061-9	Washer, 31 Flat Zinc		6
24	F81038-3	Nut, M30 Hex Zinc		6
25	098325-1	Angle, TVS Infeed Short Ptd		2
26	F81003-11	Bolt, M10-1.5x25mm Hex Head Gr 8.8		2
27	F81055-1	Washer, M10 Flat Zinc		2
28	F81002-5	Bolt, M8 X 25mm Hex Head Gr 5.8 Zinc		38
29	F81004-10	Bolt, M12x75-8.8- Hex Head Full Thread Zinc		2
30	F81056-1	Washer, M12 Flat Zinc		32
31	F81034-2	Nut, M12 Hex Nylon Zinc Lock		2
32	098942-1	Bar, Chain Support		6

REF	PART #	DESCRIPTION	COMMENTS	QTY.
33	F81001-2	Bolt, M6x20mm, Hh Full Thread Zinc		30
34	F81053-1	Washer, M6 Flat Zinc		30
35	091863	Spring, Fi 4.5x Fi 35x303		2
36	F81004-4	Bolt, M12x40 8.8 Hex Head Full Thr		2
37	F81004-55	Bolt, M12x130 8.8 Hex Head Full Thr		2
38	F81034-1	Nut, M12 Hexagon Grade 5.8 Zinc		8
43	099534-1	Leg, TVS		2
44	F81004-2	Bolt, M12x90-8.8 Hex Head Zinc		2
45	F81056-1	Washer, M12 Flat Zinc		4
46	F81034-2	Nut, M12-8 Hex Nylon Lock		2
47	F81009-6	Bolt M24x120 8.8 FE/ZN5		2
48	F81039-3	Nut M24-04-B		2
48	100623	Washer, 10.5 x 19 x 0.5 Flat		2
48	100624	Washer, 10.5 x 19 x 1 Flat		2
	098948	INFEED, TVSIV3.6I		1
	098949	INFEED, TVSIV3.6M		1
	098747	TVS Infeed, Long Complete		1
1	098742-1	TVS Infeed, Long	Available in assemblies only.	1
2	098652-1	Bar, Chain Outer Slide - Zinc		2
	096199-1	Bar, Chain Slide - Zinc		6
3	094969	Bumper, Grene 70 3201 0010 Shr Rubber		2
4	F81002-19	Bolt, M8x50-8.8 Hex Head Full Thread Zinc		4
5	F81054-1	Washer, M8 Flat Zinc		42
6	F81032-2	Nut, M8 Hex Nylon Lock Zinc		4
7	096355-1	Bushing, Spacer Zinc		2
	096350	Arm, Complete Roller Hold-down		1
8	096348-1	Arm, Roller Hold-down Wldmt/Ptd		1
9	096351-1	Shaft, Log Hold-down Wheel Zinc-Plated		1
10	096352-1	Wheel, Log Hold-down Zinc-Plated		1
11	090851	Bearing, UCFL 206 CX		2
12	097942-1	Bushing, Fi 25.5 x 32x12 Ppacer Zinc		2
13	089652	Bearing, 6005 2RS CX		3
14	089653	Ring, W47 Spring Retaining		2
15	098610-1	Bushing, Fi 25x16.5x60 -spacer Zinc		1
16	F81058-1	Washer, M16 Flat Zinc		6
17	F81006-2	Bolt, M16x100mm Hex Head Full Thrd Zinc		1
18	F81036-2	Nut, M16 Hex Nylon Zinc Lock		3
19	F81002-21	Bolt, M8x25 -8.8- Hex Socket Head Cap		4
20	F81054-4	Washer, 8.2 Split Lock Zinc		4

5 Infeed & Outfeed Tables

TVS Infeed

REF	PART #	DESCRIPTION	COMMENTS	QTY.
21	F81006-25	Bolt, M16x120 -8.8- A2E ISO 24014		2
22	096344-1	Rod, M30 (690) Hold-down Arm Threaded Zinc		1
23	F81061-9	Washer, 31 Flat Zinc		6
24	F81038-3	Nut, M30 Hex Zinc		6
25	098325-1	Angle, TVS Infeed Short Ptd		2
26	F81003-11	Bolt, M10-1.5x25mm Hex Head Gr 8.8		2
27	F81055-1	Washer, M10 Flat Zinc		2
28	F81002-5	Bolt, M8 X 25mm Hex Head Gr 5.8 Zinc		38
29	F81004-10	Bolt, M12x75-8.8 Hex Head Full Thread Zinc		2
30	F81056-1	Washer, M12 Flat Zinc		32
31	F81034-2	Nut, M12 Hex Nylon Zinc Lock		2
32	098942-1	Bar, Chain Support		8
33	F81001-2	Bolt, M6x20mm Hh Full Thread Zinc		38
34	F81053-1	Washer, M6 Flat Zinc		38
35	091863	Spring, Fi 4.5x Fi 35x303		2
36	F81004-4	Bolt, M12x40 8.8 Hex Head Full Thr.zinc		2
37	F81004-55	Bolt, M12x130 8.8 Hex Head Full Thr.zinc		2
38	F81034-1	Nut, M12 Hexagon Grade 5.8 Zinc		8
43	099534-1	Leg, TVS		2
44	F81004-2	Bolt, M12x90-8.8 Hex Head Zinc		2
45	F81056-1	Washer, M12 Flat Zinc		4
46	F81034-2	Nut, M12-8 Hex Nylon Zinc Lock		2
47	F81009-6	Bolt M24x120 8.8 Fe/Zn5		2
48	F81039-3	Nut M24-04-B		2
39	098115-1	Table, TVS Side	2 pcs with I-version table (in line), 4pcs with M-version table (manual).	2/4
40	F81004-22	Bolt, M12x30-8.8		16
41	F81056-2	Washer, M12 Split Lock Zinc		16
42	098340	Table, Log Ramp Complete	Only with I-version table (in line).	1

5.2 Infeed Table Chain Tension Wheel

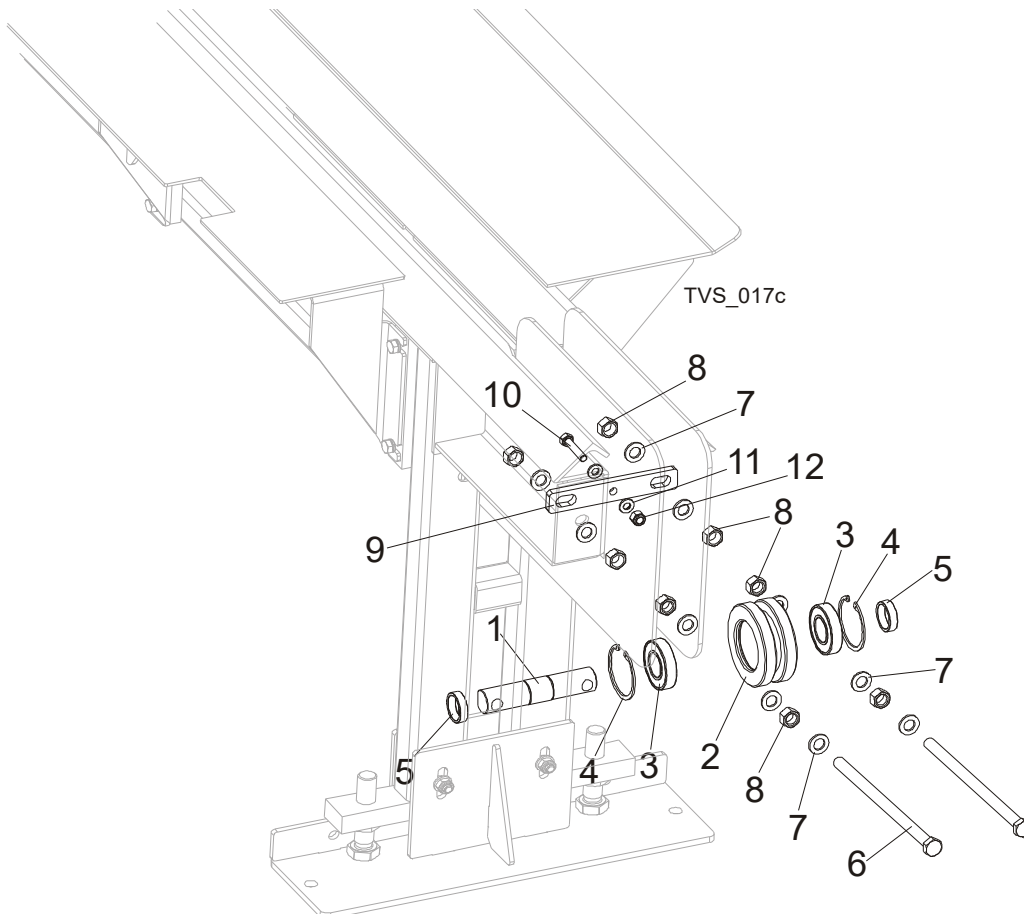

REF	PART #	DESCRIPTION	COMMENTS	QTY.
	097655	CHAIN TENSION WHEEL COMPLETE		1
1	096207-1	Shaft, Chain Tension Wheel		1
2	096208-1	Wheel, TVS Chain Tension		1
3	014811	Bearing, 6207-2RS C3 35x72x17		2
4	F81090-4	Ring, W72 Spring Retaining		2
5	096602-1	BUSHING, FI 36 X 44 X 12 -SPACER ZINC		2
6	F81006-27	BOLT, M16X290-8.8 -A2 HEX HEAD FULL THREAD ZINC		2
7	F81058-1	WASHER, M16 FLAT ZINC		8
8	F81036-1	NUT, M16 HEX GRADE 5.8 PLAIN		8
	100752	SCRAPER, TVS TENSIONING WHEEL, COMPLETE		1
9	100751-1	Holder, Tensioning Wheel Scraper		1
10	F81003-16	Bolt, M10x40-8.8		1

5 Infeed & Outfeed Tables

Chain Drive Assembly, TVS

REF	PART #	DESCRIPTION	COMMENTS	QTY.
11	F81055-1	Washer, 10.5 Flat Zinc		2
12	F81033-1	Nut, M10-8-B Nylon Hex Zinc Lock		1

5.3 Chain Drive Assembly, TVS

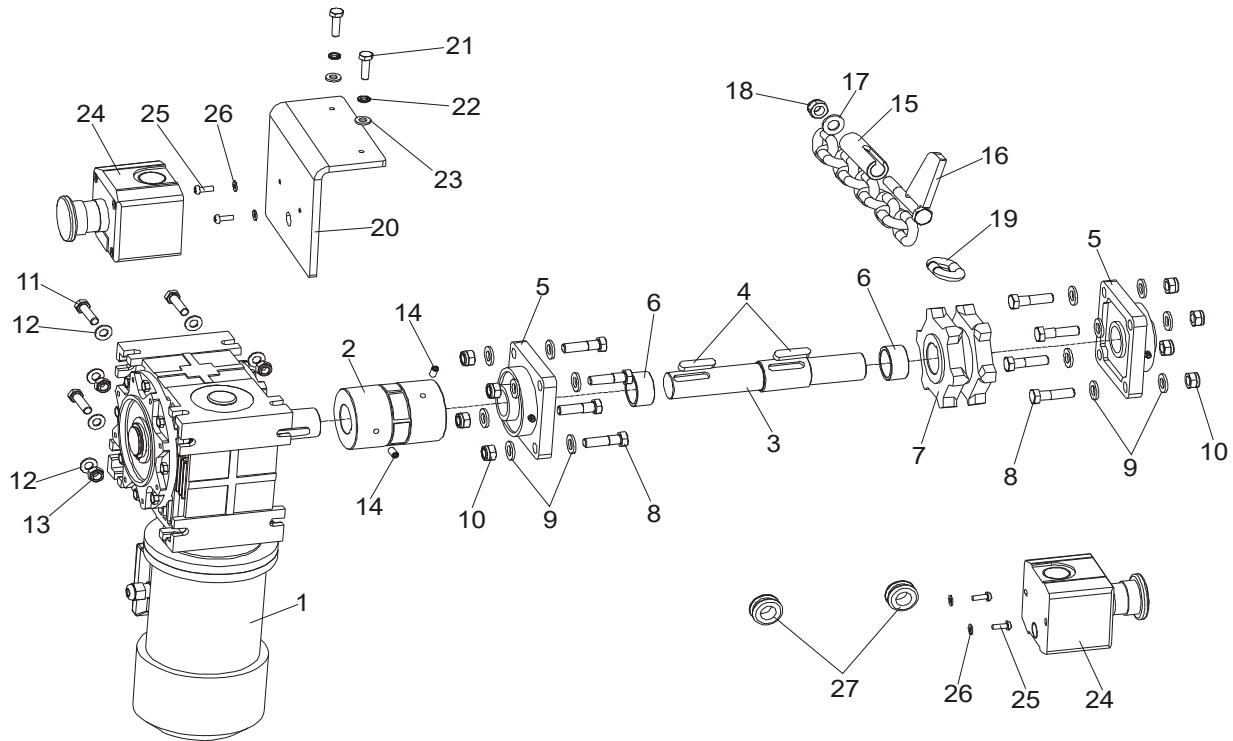

REF	PART #	DESCRIPTION	COMMENTS	QTY.
	098671	CHAIN DRIVE, TVS COMPLETE		1
1	098663	Motoreducer, MR-80/64/1.1-1400/K3/V6		1
2	098664	Coupling, Rotex-38 ST 92 1A 38X45, 1A 35X45		1
	505216-S	Connecting Element, 38-92 SHA 098664 Coupler		1
3	096203-1	Shaft, TVS Chain Drive Zinc-plated		1
4	091312	Key, A10x8x45 Parallel		2
5	097668	Bearing, UCF 207 w/Housing		2
6	096125-1	Bushing, Fi 38x30.5x22-spacer Zinc		2
7	097657	Sprocket, 16B 20Z		1
8	F81004-32	Bolt, M12x45-8.8 Hex Head Zinc		8
9	F81056-1	Washer, M12 Flat Zinc		16
10	F81034-2	Nut, M12 Hex Nylon Zinc Lock		8
11	F81003-16	Bolt, M10x40-8.8 Hex Head Full Thread Zinc		4

Infeed & Outfeed Tables

Chain Drive Assembly, TVS

5

REF	PART #	DESCRIPTION	COMMENTS	QTY.
12	F81055-1	Washer, M10 Flat Zinc		8
13	F81033-1	Nut, M10 Nylon Hex Zinc Lock		4
14	F81014-2	Screw, M8x16-33H Hex Socked Flat Point Set		2
15	097650	COMPLETE CHAIN W/DOGS	Occurs in combination: Short Infeed + Short Outfeed.	1
	097649	Chain, TVS		1
	098809	CHAIN, L.13321 W/DOGS	Occurs in combination: Short Infeed + Medium Outfeed.	1
	098808	Chain		1
	098987	COMPLETE CHAIN W/DOGS	Occurs in combination: Short Infeed + Long Outfeed.	1
	098986	Chain		1
	098987	CHAIN, L.15615 W/DOGS	Occurs in combination: Long Infeed + Medium Outfeed.	1
	098986	Chain		1
	098812	CHAIN, L.17785 W/DOGS	Occurs in combination: Long Infeed + Long Outfeed.	1
	098811	Chain		1
16	097647-1	Dog	Dogs amount depend on chain type.	6-9
17	F81056-1	Washer, M12 Flat Zinc		1
18	F81034-2	Nut, M12 Hex Nylon Zinc Lock		1
19	098661	Link, Chain Master		1
20	098814-1	BRACKET, EMERGENCY SWITCH TVS		1
21	F81001-2	BOLT, M6X20MM HH FULL THREAD ZINC		2
22	F81053-3	WASHER, M6 SPLIT LOCK ZINC		2
23	F81053-1	WASHER, M6 FLAT ZINC		2
24	E22703-P	SWITCH, EMERGENCY XALJ174F		2
25	F81011-43	SCREW, M4X12-5,8-B CROSS RECESSED PAN		4
26	F81051-2	WASHER, 4.3 FLAT ZINC		4
27	086188	GROMMET, 20/13 RUBBER		2

5.4 TVS Outfeed

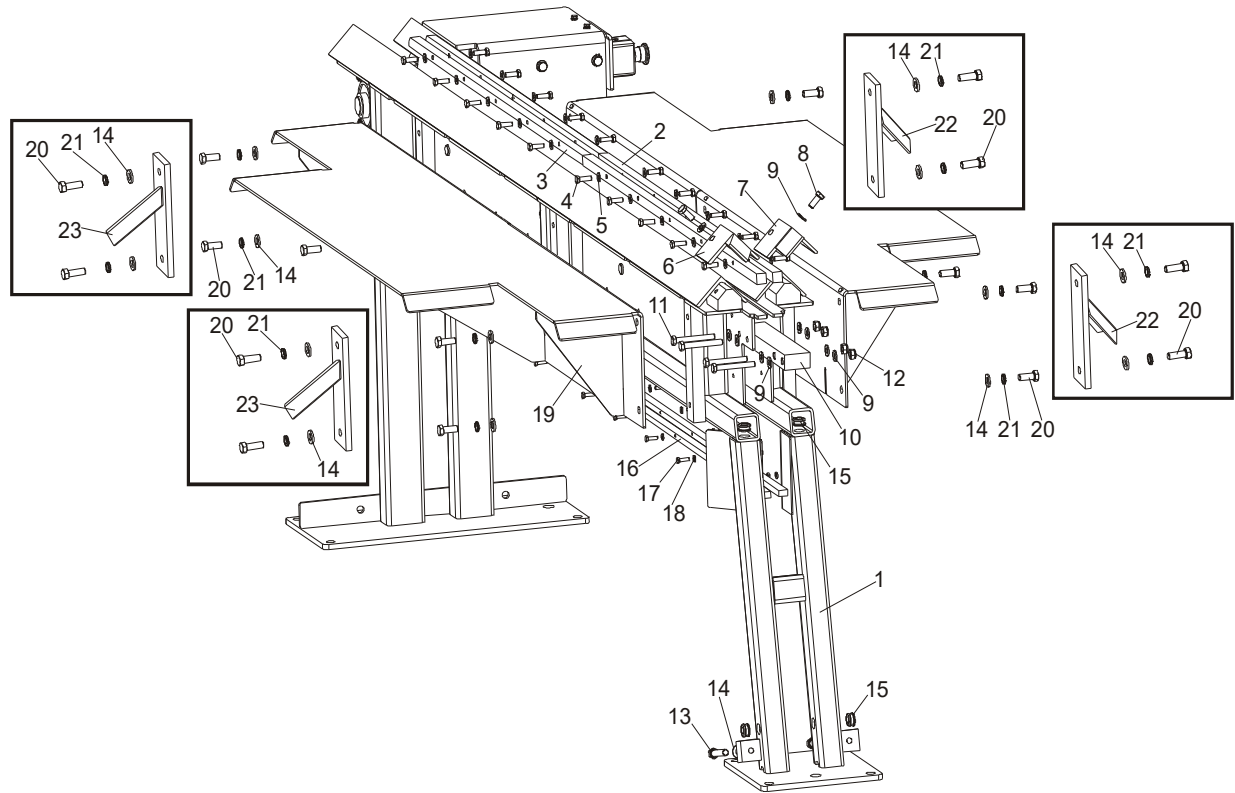

REF	PART #	DESCRIPTION	COMMENTS	QTY.
	098950	OUTFEED, TVSOV2.4I		1
	098951	OUTFEED, TVSOV2.4M		1
	097642	Outfeed Table, TVS Complete		1
1	097644-1	Table, TVS Outfeed		1
2	096199-1	Bar, Chain Slide Zinc		2
3	098652-1	Bar, Chain Outer Slide Zinc		2
4	F81002-5	Bolt, M8 X 25mm Hex Head Gr 5.8 Zinc		20
5	F81054-1	Washer, M8 Flat Zinc		20
6	098315-1	Block, Guide Wldmt/ptd - Left		1
7	098670-1	Block, Guide Wldmt/ptd - Right		1
8	F81003-11	Bolt, M10-1.5x25mm Hex Head Gr 8.8		2
9	F81055-1	Washer, M10 Flat Zinc		10
10	098667-1	Connector, Table Zinc-plated		1
11	F81003-50	Bolt, M10x80 8.8 Hex Head Zinc		4
12	F81033-1	Nut, M10 Nylon Hex Zinc Lock		4
13	F81004-21	Bolt, M12x75-8.8-hex Head Zinc		2

REF	PART #	DESCRIPTION	COMMENTS	QTY.
14	F81056-1	Washer, M12 Flat Zinc		14
15	086188	Grommet, 20/13 Rubber		4
16	098942-1	Bar, Chain Support		4
17	F81001-2	Bolt, M6x20mm Hex Head Full Thread Zinc		20
18	F81053-1	Washer, M6 Flat Zinc		20
19	097932-1	Table, Side Ptd		2
20	F81004-22	Bolt, M12x30-8.8	First number of the fasteners concerns I-version table (in line), second concerns M-version table (manual).	8/12
21	F81056-2	Washer, M12 Split Lock Zinc		8/12 1
22	097885-1	Angle, Board Removal Left	Only in I-version table (in line).	2
23	097886-1	Angle, Board Removal Right		2
	098952	OUTFEED, TVSOV3.6I		1
	098953	OUTFEED, TVSOV3.6M		1
	098755	Outfeed, Medium Complete		1
1	098754-1	Outfeed, TVS Medium		1
2	096199-1	Bar, Chain Slide - Zinc		2
3	098652-1	Bar, Chain Outer Slide - Zinc		2
	098753-1	Bar, Chain Short Slide- Zinc		2
4	F81002-5	Bolt, M8 X 25mm Hex Head Gr 5.8 Zinc		28
5	F81054-1	Washer, M8 Flat Zinc		28
6	098315-1	Block, Guide Wldmt/ptd - Left		1
7	098670-1	Block, Guide Wldmt/ptd - Right		1
8	F81003-11	Bolt, M10-1.5x25mm Hex Head Gr 8.8		2
9	F81055-1	Washer, Flat M10 Zinc		10
10	098667-1	Connector, Table Zinc-plated		1
11	F81003-50	Bolt, M10x80 -8.8- Hex Head Zinc		4
12	F81033-1	Nut, M10 Nylon Hex Zinc Lock		4
13	F81004-21	Bolt, M12x75-8.8-hex Head Zinc		2
14	F81056-1	Washer, M12 Flat Zinc		14
15	086188	Grommet, 20/13 Rubber		4
16	098942-1	Bar, Chain Support		4
	098943-1	Bar, Chain Short Support		2
17	F81001-2	Bolt, M6x20mm Hex Head Full Thread Zinc		28
18	F81053-1	Washer, M6 Flat Zinc		28
19	097932-1	Table, Side		2
20	F81004-22	Bolt M12x30-8.8		8/12 ¹
21	F81056-2	Washer, M12 Split Lock Zinc		8/12 ¹
22	097885-1	Angle, Board Removal Left	Only in I-version table (in line).	2
23	097886-1	Angle, Board Removal Right		2
	098954	OUTFEED, TVSOV4.8I		1
	098955	OUTFEED, TVSOV4.8M		1

5 Infeed & Outfeed Tables

TVS Outfeed

REF	PART #	DESCRIPTION	COMMENTS	QTY.
	098796	Outfeed, TVS Long Complete		1
1	098795-1	Outfeed, TVS		1
2	096199-1	Bar, Chain Slide -zinc		4
3	098652-1	Bar, Chain Outer Slide -zinc		2
	098753-1	Bar, Chain Short Slide -zinc		2
4	F81002-5	Bolt, M8 x 25mm Hex Head Gr 5.8 Zinc		36
5	F81054-1	Washer, M8 Flat Zinc		36
6	098315-1	Block, Guide Wldmt/ptd - Left		1
7	098670-1	Block, Guide Wldmt/ptd - Right		1
8	F81003-11	Bolt, M10-1.5x25mm Hex Head Gr 8.8		2
9	F81055-1	Washer, M10 Flat Zinc		10
10	098667-1	Connector, Table Zinc-plated		1
11	F81003-50	Bolt, M10x80-8.8 Hex Head Zinc		4
12	F81033-1	Nut, M10 Nylon Hex Zinc Lock		4
13	F81004-21	Bolt, M12x75-8.8 Hex Head Zinc		2
14	F81056-1	Washer, M12 Flat Zinc		14
15	086188	Grommet, 20/13 Rubber		4
16	098942-1	Bar, Chain Support		6
	098943-1	Bar, Chain Support Short		2
17	F81001-2	Bolt, M6x20mm Hex Head Full Thread Zinc		38
18	F81053-1	Washer, M6 Flat Zinc		38
19	097932-1	Table, Side Ptd		4
20	F81004-22	Bolt M12x30-8.8		16/24 1
21	F81056-2	Washer, M12 Split Lock Zinc		16/24 1
22	097885-1	Angle, Board Removal Left	Only in I-version table (in line).	4
23	097886-1	Angle, Board Removal Right		4

5.5 Additional Hold-Down Roller Kit (Optional)

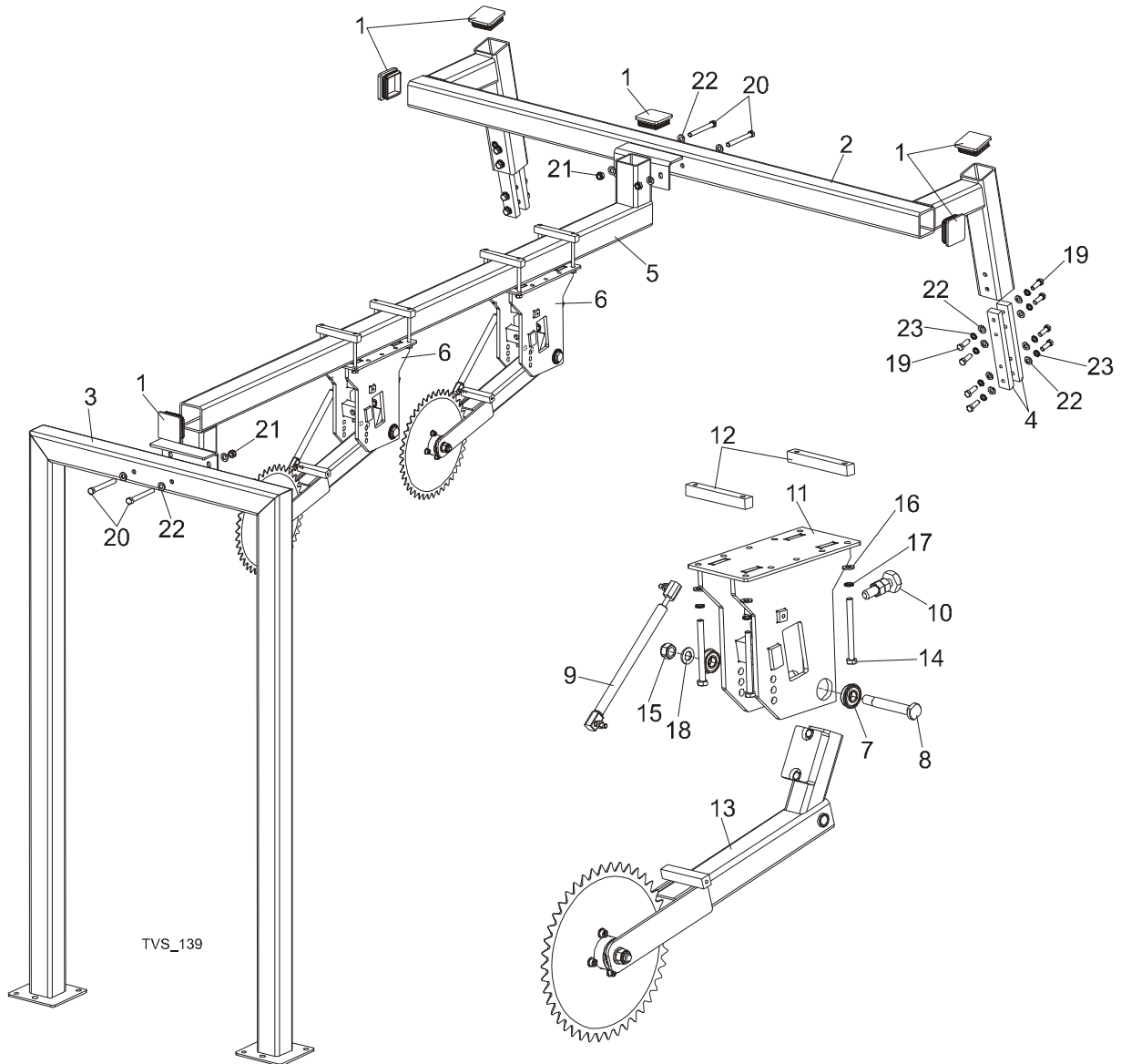

REF	PART #	DESCRIPTION	COMMENTS	QTY.
	101457	ADDITIONAL HOLD-DOWN ROLLER KIT, TVS 2.4		1
	101458	ADDITIONAL HOLD-DOWN ROLLER KIT, TVS 3.6		1
	101459	ADDITIONAL HOLD-DOWN ROLLER KIT, TVS 4.8		1

5

Infeed & Outfeed Tables*Additional Hold-Down Roller Kit (Optional)*

REF	PART #	DESCRIPTION	COMMENTS	QTY.
1	089644	Cap, Hold-Down Roller Frame		6
2	100731-1	Support Construction, Hold-Down Roller Rear		1
3	100738-1	Frame, Hold-Down Roller Construction Front		1
4	100756-1	Bar, Hold-Down Roller Support Mount		4
5	101181-1	Middle Tube, Hold-Down Roller Construction (Short Table)		1
	100945-1	Middle Tube, Hold-Down Roller Construction (Middle Table)		1
	101184-1	Middle Tube, Hold-Down Roller Construction (Long Table)		1
6	101450	Hold-Down Roller, TVS Additional Complete		1/2/3
7	086395	Bearing w/Snap Ring LT15 6203-2RS		2
8	086404	Bolt, Arm Bearnig Mount		1
9	089212	Spring, 340N Gas Complete		1
10	093710	Bolt, M16 w/2 Nuts		1
11	100746-1	Support, Hold-Down Roller Upper		1
12	100757-1	Bar, Hold-Down Roller Support Mount		2
13	100973	Roller, TVS Hold-Down Additional		1
14	F81003-19	Bolt, M10 x 115-8.8 Zinc Lock		4
15	F81036-2	Nut, M16 Hex Nylon Zinc Lock		1
16	F81055-1	Washer, 10.5 Flat Zinc		4
17	F81055-2	Washer, 10.2 Split Lock Zinc		4
18	F81058-1	Washer, 17 Flat Zinc		1
19	F81004-24	Bolt, M12x35-8.8 Zinc Hex Head Full		16
20	F81004-47	Bolt, M12x110-8.8 Zinc Hex Head Full		4
21	F81034-2	Nut, M12-8 Hex Nylon Zinc Lock		4
22	F81056-1	Washer, 13 Flat Zinc		24
23	F81056-2	Washer, Z12.2 Split Lock Zinc		16

5.6 Tables Decals

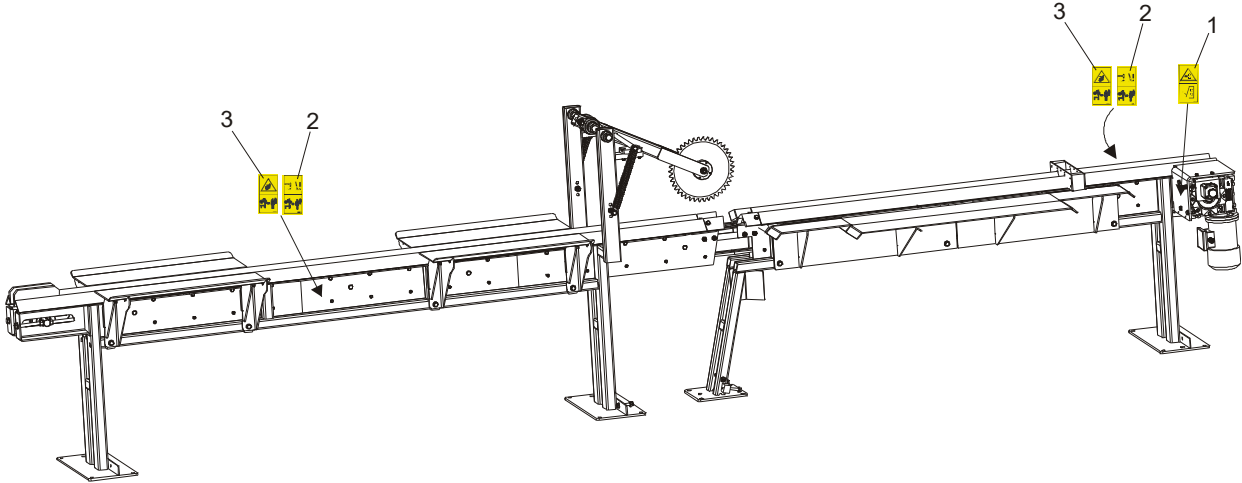

REF	PART #	DESCRIPTION	COMMENTS	QTY.
	099580	DECALS KIT, PICTOGRAMS, INFEE&OUT-FEED TABLES		1
1	099220	Decal, Close Guards Prior To Operating The Machine		1
2	096314	Decal, Keep All Persons A Safe Distance		2
3	099221	Decal, Keep A Safe Distance		2

SECTION 6 INCLINE LOG DECK

6.1 Infeed Assembly

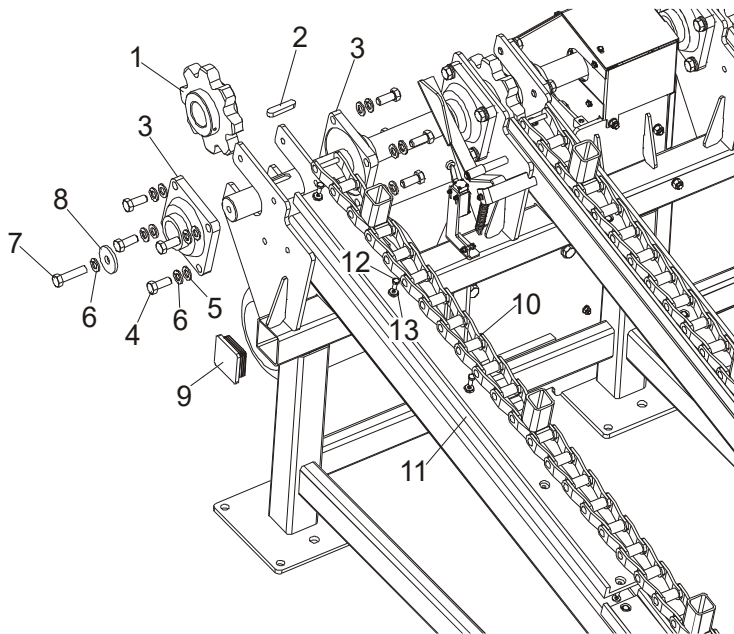

TVS_039

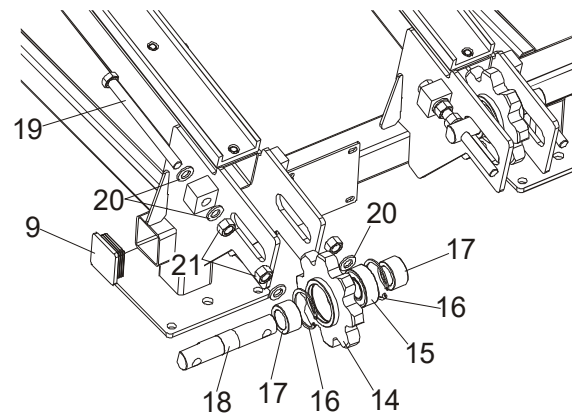

REF	PART #	DESCRIPTION	COMMENTS	QTY.
	097999	TVS INCLINE LOG DECK		1
1	089888-1	Sprocket, Z8 Oxidized		4
2	098029	Key, A16x10x70 Parallel		4

REF	PART #	DESCRIPTION	COMMENTS	QTY.
3	089889	Bearing, Ucf 211w/housing (55 Dia. Shaft)		8
4	F81006-13	Bolt, M16x40-8.8 Hex Head Full Thread Zinc		32
5	F81058-1	Washer, 17 Flat Zinc		32
6	F81058-2	Washer, 16.3 Split Lock Zinc		32
7	F81006-1	Bolt, M16x65-8.8-b Hex Head Full Thread Zinc		4
8	098012-1	Washer, TVS Special		2
9	089644	Cap, Frame Tube		4
10	098479-1	Chain, TVS Incline Log Deck		4
11	033722	Channel, Uhmw Conveyor		8
12	F81002-1	Bolt, M8x20-5.8 Hex Head Full Thread Zinc		40
13	F81053-11	Washer, 6.5 Special Flat Zinc		40
14	089919-1	Sprocket, Z8 Rear Oxidized		4
15	088449	Bearing, 3208B.2RSR.TVH FAG		4
16	F81090-25	Ring, W80 Inside Retaining		8
17	089916-1	Bushing, Sprocket Spacer		8
18	089915-1	Shaft, Chain Tension Sprocket		4
19	F81007-1	Bolt, M20x240-8.8 Hex Head Full Thread Zinc		8
20	F81059-2	Washer, 21 Flat Zinc		24
21	F81037-1	Nut, M20-8 Hex Zinc		16

6.2 Limit Switch Assembly

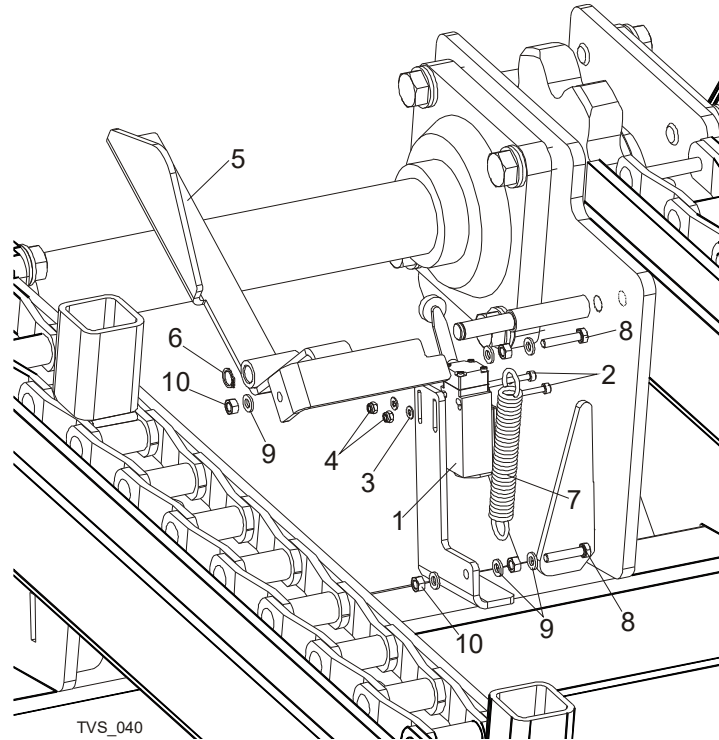

REF	PART #	DESCRIPTION	COMMENTS	QTY.
1	086469	LIMIT SWITCH, GLCB01A2B		1
2	F81011-34	SCREW, M4x35-8.8 HEX SOCKET HEAD CAP ZINC		2
3	F81051-2	WASHER, 4.3 FLAT ZINC		2
4	F81029-1	NUT, M4-B HEX NYLON LOCK ZINC		2
5	098474-1	ARM, TVS LIMIT SWITCH ACTIVATOR - COMPLETE		1
6	F81090-14	RING, Z12 OUTSIDE RETAINING		1
7	091865	SPRING, FI 1.9 X FI 14.2 X 104		1
8	F81001-13	BOLT, M6x30 5.8 HEX HEAD FULL THREAD		2
9	F81053-1	WASHER, 6.4 FLAT ZINC		6
10	F81031-1	NUT, M6-8 HEX ZINC		4

6.3 Drive Assembly

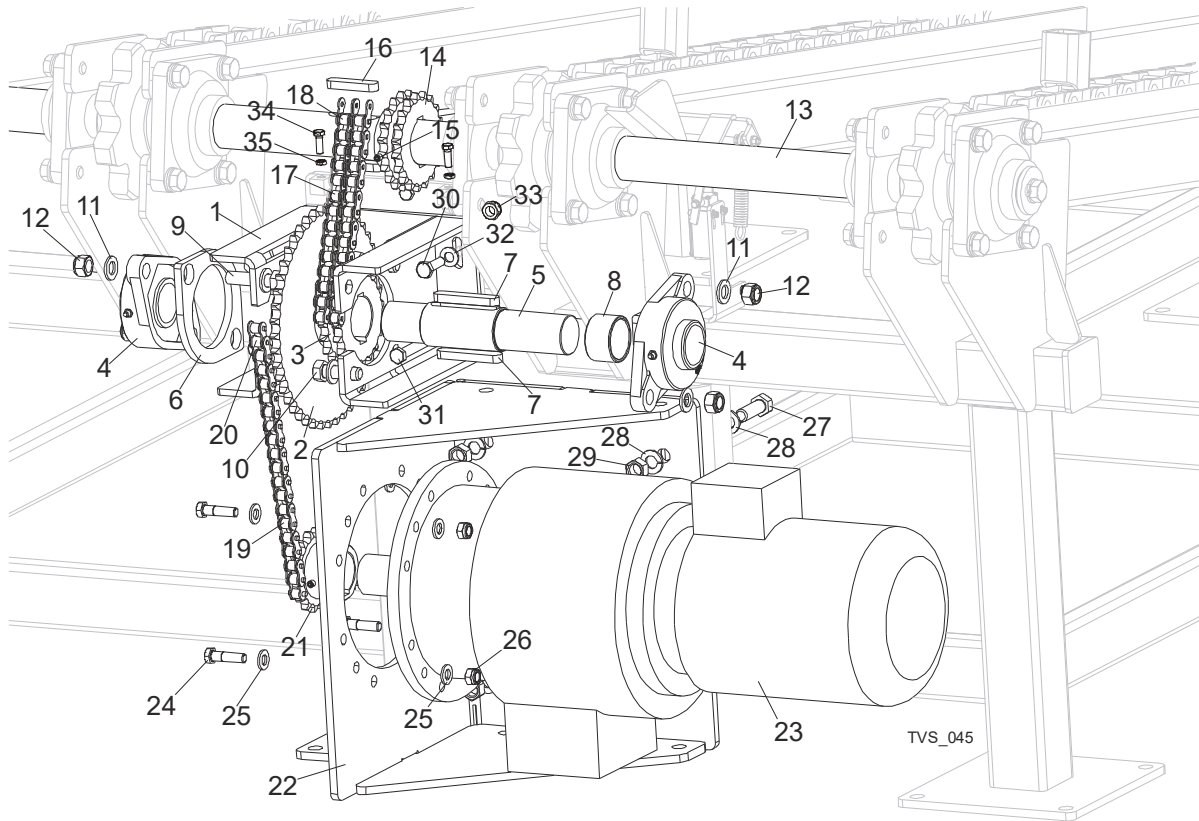

REF	PART #	DESCRIPTION	COMMENTS	QTY.
	098424	GEAR ASSEMBLY, TVS INCLINE LOG DECK		1
1	098422-1	Bracket Weldment, Tvs Sprocket Mounting		1
2	089894-1	Sprocket, 12B Z45 Oxidized		1
3	098013-1	Sprocket, 12B Z19		1
4	098824	Bearing, UCFL 210 CX W/housing		2
5	098419-1	Shaft, Intermediate Sprocket Zinc-plated		1
6	099106-1	Plate, Fl 210 Bearing Spacer		1
7	099131	Key, A16x10x90 Parallel		2
8	098011-1	Spacer, TVS Sprocket		1
9	099647	Bolt, M16		2
10	F81006-7	Bolt, M16x50-8.8 Hex Head Full Thread Zinc		2
11	F81058-1	Washer, 17 Flat Zinc		8
12	f81036-2	Nut, M16-8 Hex Nylon Lock Zinc		4

6

Incline Log Deck*Drive Assembly*

REF	PART #	DESCRIPTION	COMMENTS	QTY.
13	098010	SHAFT, TVS INCLINE LOG DECK MAIN		1
14	098013-1	SPROCKET, 12B Z19		1
15	f81014-1	SCREW, M8X8-33H HEX SOCKET SET FLAT POINT ZINC		4
16	098029	KEY, A16X10X70 PARALLEL		2
17	099250	CHAIN, 12B-2-41 (0.8 RM)		1
18	099249	LINK, 12B-1PZ CHAIN		1
19	099248	CHAIN, 12B-1-65 (1.25 RM)		1
20	090713	LINK, 12B-1PZ CHAIN		1
21	090303-1	SPROCKET, 12B Z16 OXIDIZED		1
22	089897-1	BRACKET WELDMENT, DECK MOTOR MOUNT		1
23	089892	MOTOREDUCER, SBCM 180/112M-4/32		1
24	f81004-32	BOLT, M12X45-8.8 HEX HEAD ZINC		4
25	f81056-1	WASHER, 13 FLAT ZINC		8
26	f81034-2	NUT, M12-8 HEX NYLON LOCK ZINC		4
27	f81006-7	BOLT, M16X50-8.8 HEX HEAD FULL THREAD ZINC		4
28	f81058-1	WASHER, 17 FLAT ZINC		8
29	f81036-1	NUT, M16-5.8 HEX ZINC		4
30	F81004-4	BOLT, M12X40-8.8 HEX HEAD FULL THREAD ZINC		2
31	F81004-38	BOLT, M12X120 8.8 HEX HEAD ZINC		2
32	F81056-1	WASHER, 13 FLAT ZINC		8
33	F81034-1	NUT, M12-8-B HEX ZINC		4
34	F81003-4	BOLT, M10X50MM,HEX HEAD FULL THRD ZINC		2
35	F81033-3	NUT, M10-8-B-FE		

6.4 Chain Guards

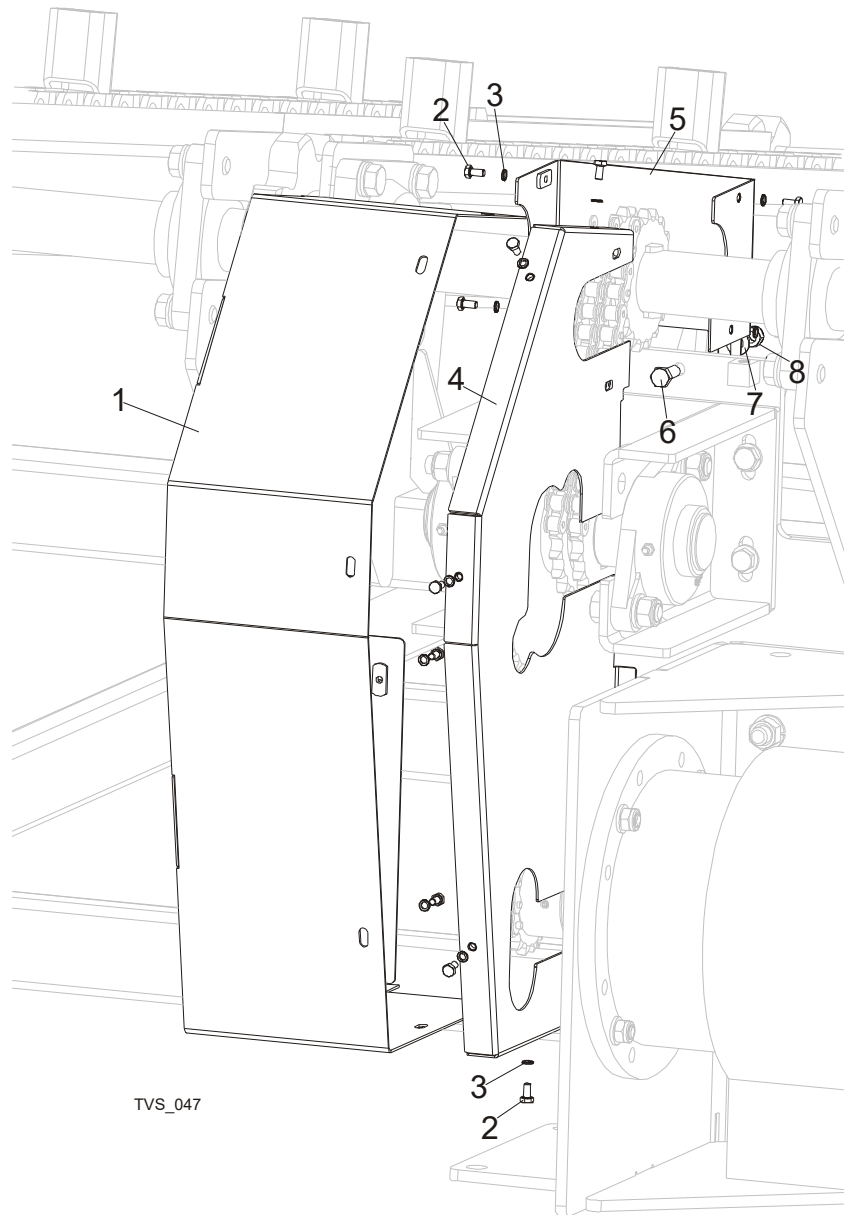

REF	PART #	DESCRIPTION	COMMENTS	QTY.
1	098467-1	GUARD, TVS ILD GEAR - MAIN		1
2	F81001-7	BOLT, M6X12-8.8 HEX HEAD FULL THREAD ZINC		11
3	F81053-3	WASHER, Z 6.1 SPLIT LOCK ZINC		11

6 Incline Log Deck

Decals

REF	PART #	DESCRIPTION	COMMENTS	QTY.
4	098470-1	GUARD, TVS ILD GEAR - SIDE		1
5	098469-1	GUARD, TVS REAR		1
6	F81003-2	BOLT, M10X30-5.8 HEX HEAD FULL THREAD ZINC		1
7	F81055-1	WASHER, 10.5 FLAT ZINC		1
8	F81033-1	NUT, M10-8-B HEX NYLON LOCK ZINC		1

6.5 Decals

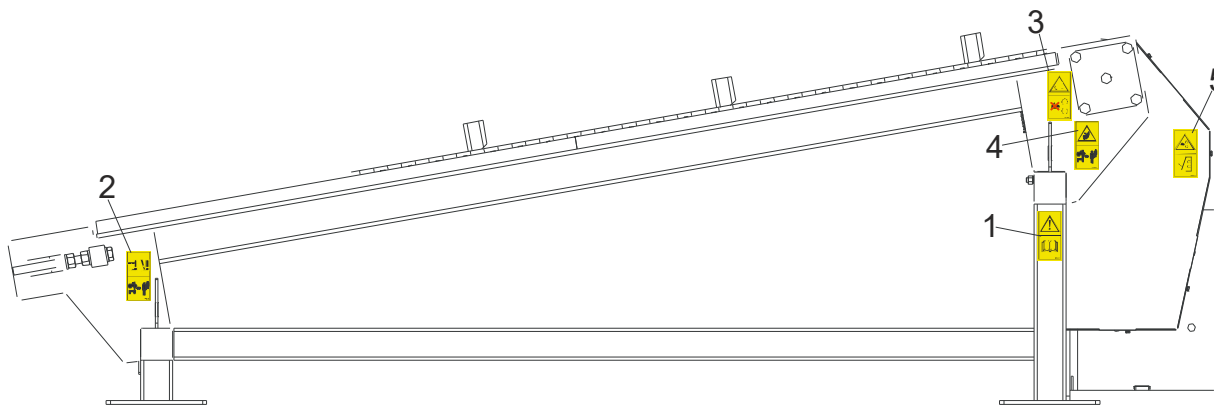

TVS_048

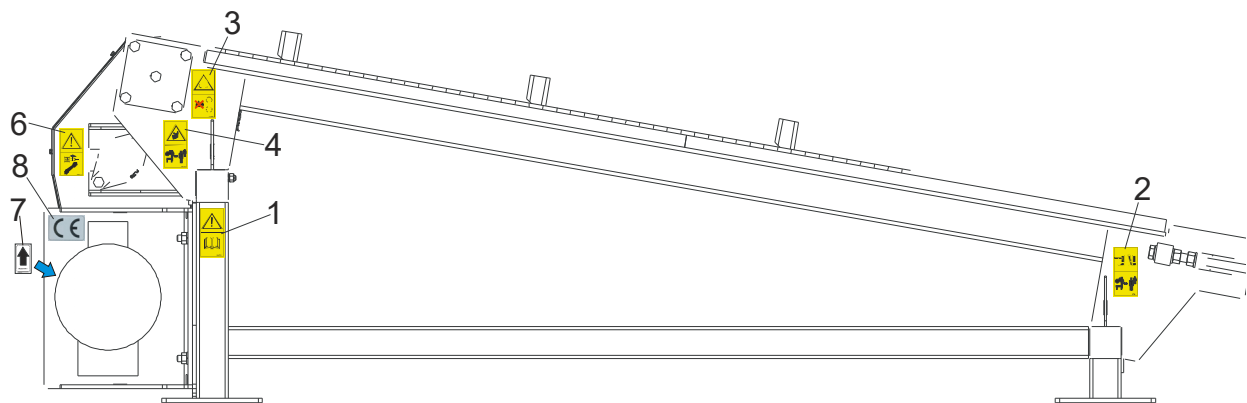

REF	PART #	DESCRIPTION	COMMENTS	QTY.
	099579	DECALS KIT, PICTOGRAMS, INCLINE LOG DECK		1
1	096317	Decal, Read Operator's Manual (Pictogram)		2
2	096314	Decal, Keep Away Warning (Pictogram)		2
3	099540	Decal, Gear Danger (Pictogram)		2

REF	PART #	DESCRIPTION	COMMENTS	QTY.
4	099221	Decay, Keep Away Warning (Pictogram)		2
5	099220	Decal, Close All Guards And Covers Before Starting The Machine		1
6	098177	Decal, Disconnect And Lock Out Power Supply Before Servicing (Pictogram)		1
7	S20097H	Decal, 1400 RPM Motor Direction		1
8	P85070	DECAL, CE - CERTIFIED SAWMILL		1

SECTION 7 CROSS TRANSFER DECK

7.1 Front Module & Chains

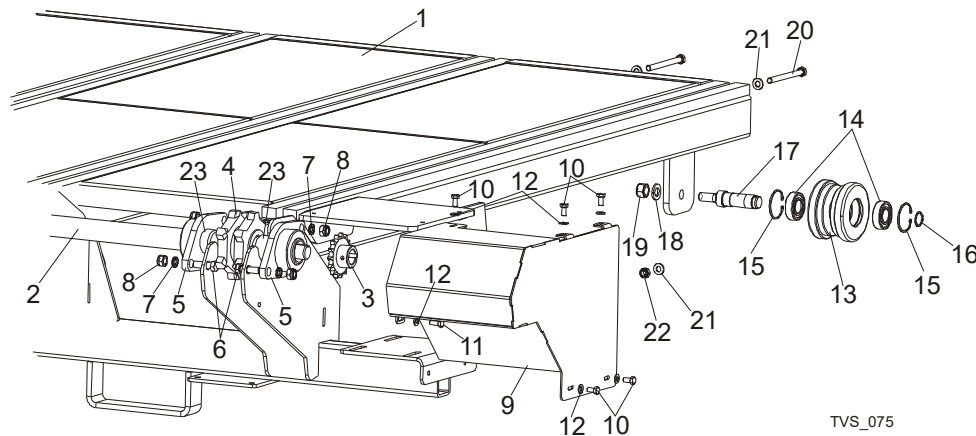

REF	PART #	DESCRIPTION	COMMENTS	QTY.
	099556	COMPLETE FRONT MODULE		1
1	097899-1	Frame Weldment, Ctd Front		1
2	097893	Shaft, Ctd Drive		1
3	095162	Sprocket, 10B Z 15 Incline Conveyor		1
4	097657	Sprocket, 16B 20Z		4
5	097898	Bearing, FYTB 40 KG		8
6	F81004-1	Bolt, M12x40-8.8 Hex Head Zinc		16
7	F81056-2	Washer, M12 Split Lock Zinc		16
8	F81034-2	Nut, M12-8 Hex Nylon Zinc Lock		16
9	097903-1	Cover, Ctd Chain		1
10	F81002-20	Bolt, M8x16-8.8 Hex Head Zinc		5
11	F81002-4	Bolt, M8x20-8.8-b Hex Head Full Thread Zinc		1
12	F81054-1	Washer, 8.4 Flat, Zinc		6
	098492	Wheel, Ctd Complete		4
13	098493	Tensioner, Ctd Chain		1
14	087353	Bearing, SKF 6205-2RS Roller		2
15	F81090-6	Ring, W52 Inside Retaining		2
16	F81090-22	Ring, 25Z Outside Retaining		1
17	098494	Shaft, Ctd Chain Tensioner		1
18	F81058-2	Washer, 16.3 Split Lock Zinc		4
19	F81036-2	Nut, M16-8 Hex Nylon Zinc Lock		4
20	F81003-18	Bolt, M10x125-8.8 Hex Head Zinc		6
21	F81055-1	Washer, 10.5 Flat Zinc		12

REF	PART #	DESCRIPTION	COMMENTS	QTY.
22	F81033-1	Nut, M10-8-b Hex Nylon Zinc Lock		6
23	099958-1	Bushing, Fi 40 x Fi 48x14 Spacer		8
	099310	CHAIN, SLPCTD3.6 ZINC-PLATED		4
	099571	CHAIN, SLPCTD5.4		4
	099572	CHAIN, CTC7.2		4

7.2 Central Module

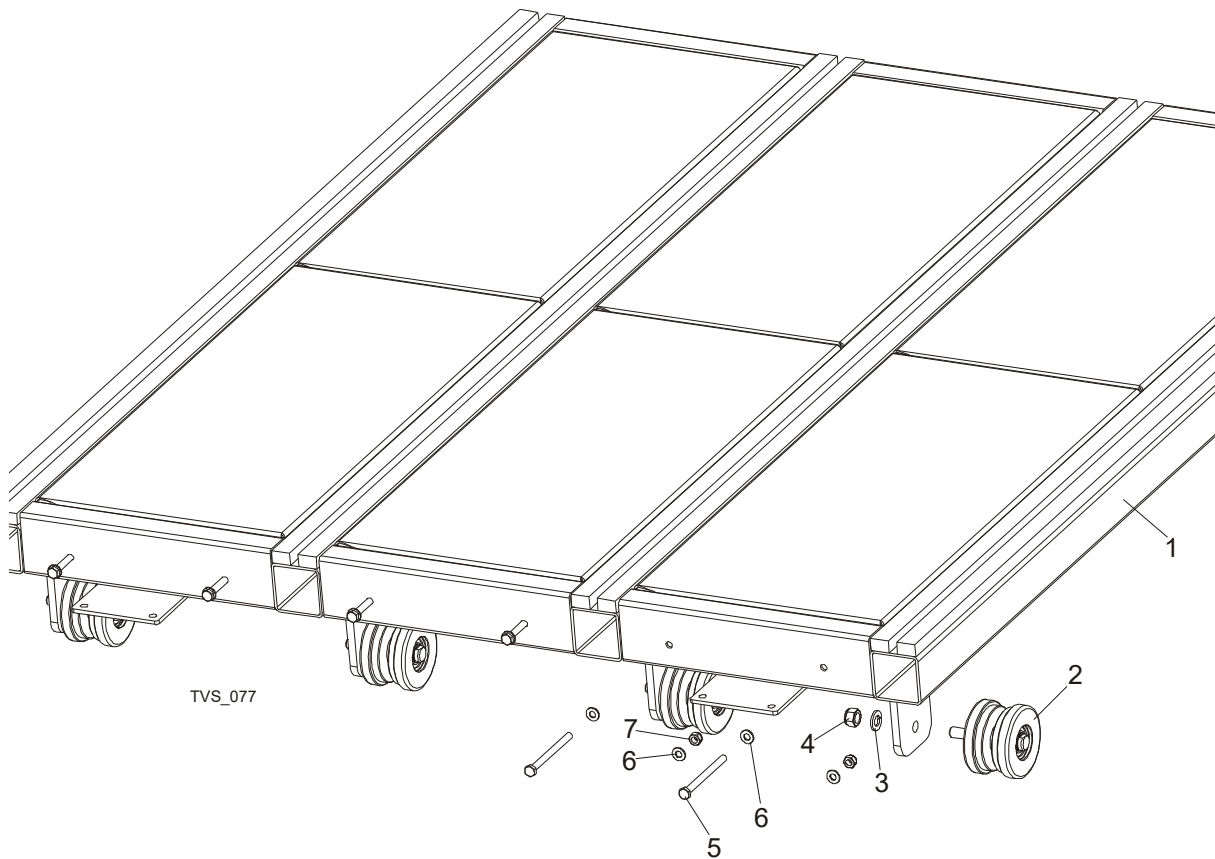

REF	PART #	DESCRIPTION	COMMENTS	QTY.
	099557	COMPLETE CENTRAL MODULE	Used on CTD5.4 - 1 piece and on CTD7.2 - 2 pieces.	1/2
1	098125-1	Module, Ctd Central Painted		1
2	098492	Wheel, Ctd Complete		4
3	F81058-2	Washer, 16.3 Split Lock Zinc		4
4	F81036-2	Nut, M16-8 Hex Nylon Zinc Lock		4

7 Cross Transfer Deck

Rear Module

REF	PART #	DESCRIPTION	COMMENTS	QTY.
5	F81003-18	Bolt, M10x125-8.8 Hex Head Zinc		6
6	F81055-1	Washer, 10.5 Flat Zinc		12
7	F81033-1	Nut, M10-8-B Hex Nylon Zinc Lock		6

7.3 Rear Module

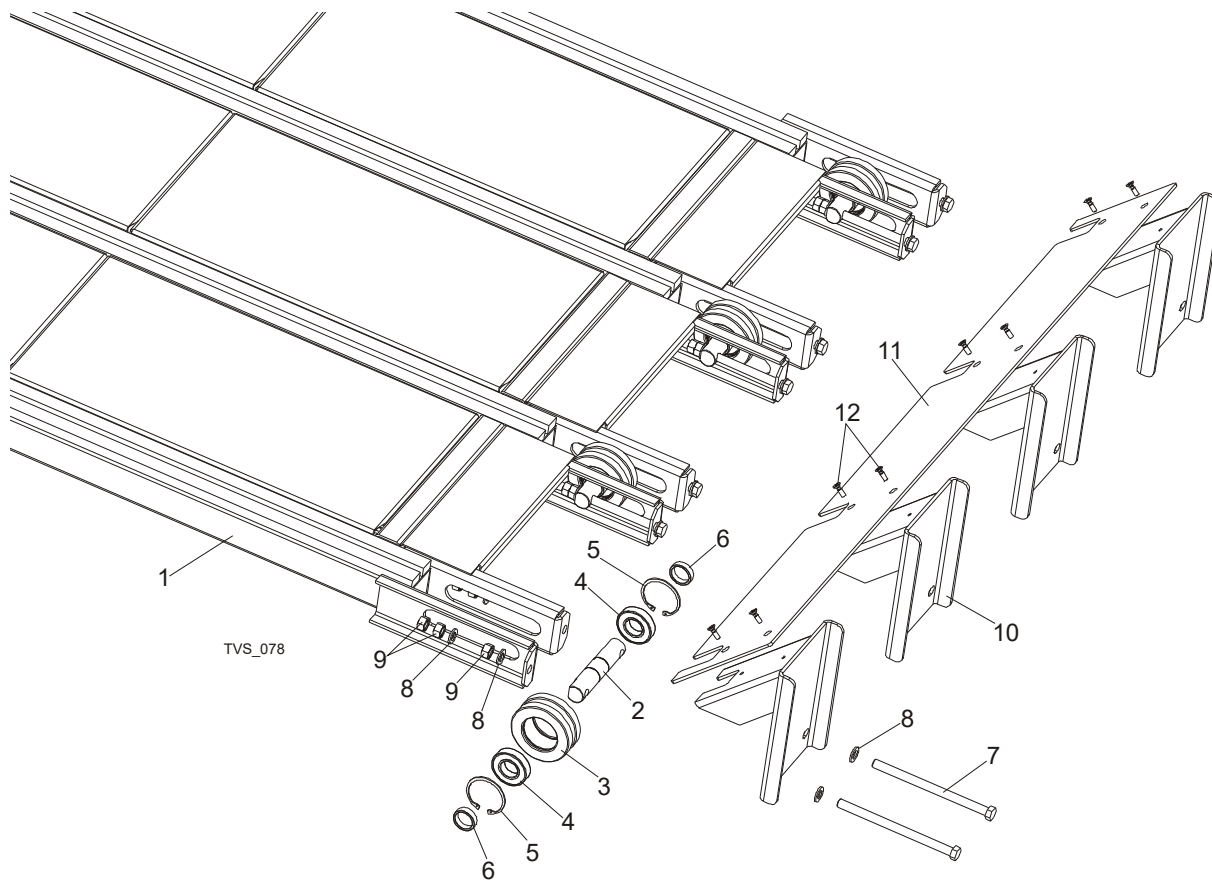

REF	PART #	DESCRIPTION	COMMENTS	QTY.
	099558	COMPLETE REAR MODULE		1
1	097900-1	Frame Weldment, Ctd Rear Ptd		1
	097655	Complete Chain Tension Wheel		4
2	096207-1	Shaft, Chain Tension Wheel		1
3	096208-1	Wheel, Tvs Chain Tension		1
4	014811	Bearing, 6207-2RS C3 35x72x17		2
5	F81090-4	Ring, W72 Inside Retaining		2
6	099959-1	Bushing, Fi 36x Fi 44x22 Spacer Zinc		8
7	F81006-29	Bolt, M16x240-8.8-A2 Full Thread		8

REF	PART #	DESCRIPTION	COMMENTS	QTY.
8	F81058-1	Washer, 17 Flat Zinc		24
9	F81036-1	Nut, M16-5.8 Hex Zinc		24
	099560	BUMPER ASSEMBLY		1
10	098223-1	Bracket, Bumper Mounting		4
11	098496-1	Plate, Ctd Bumper		1
12	F81002-51	Screw, M8x25 Cross Recessed Countersunk Head		8

7.4 Cross Transfer Deck Drive

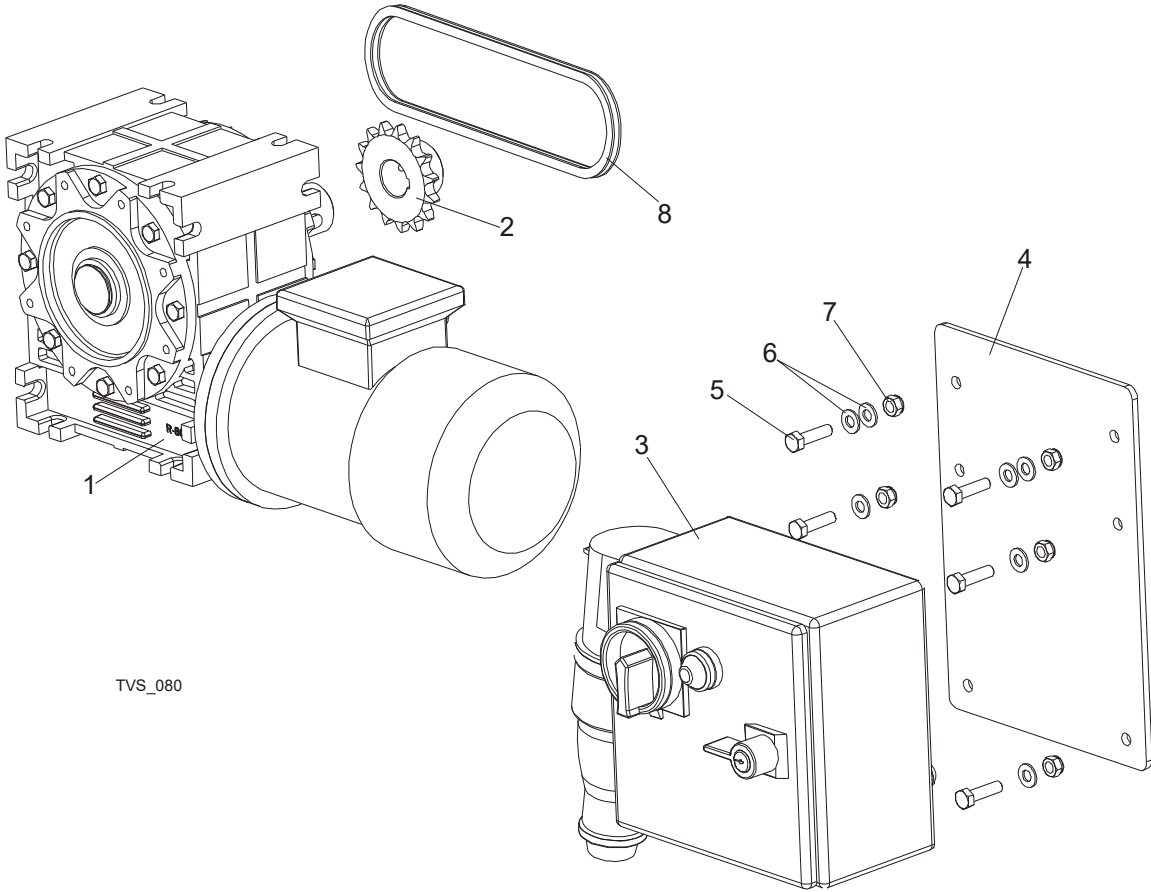

REF	PART #	DESCRIPTION	COMMENTS	QTY.
	099559	MOTOR KIT		1
1	098663	Motoreducer, MR-80/64-1.1-1400/K3/V6		1
2	095162	Sprocket, 10B Z 15 Incline Conveyor		1
3	098826	Box, Ctd Electric		1

7 Cross Transfer Deck

Leg Kits

REF	PART #	DESCRIPTION	COMMENTS	QTY.
4	099550-1	Panel, Ctd Electric Box		1
5	F81002-2	Bolt, M8x30-5.8 Hex Head Full Thread Zinc		6
6	F81054-1	Washer, 8.4 Flat Zinc		8
7	F81032-2	Nut, M8-8-B Hex Nylon Zinc Lock		6
8	099781	Chain, 10B-48PZ		1

7.5 Leg Kits

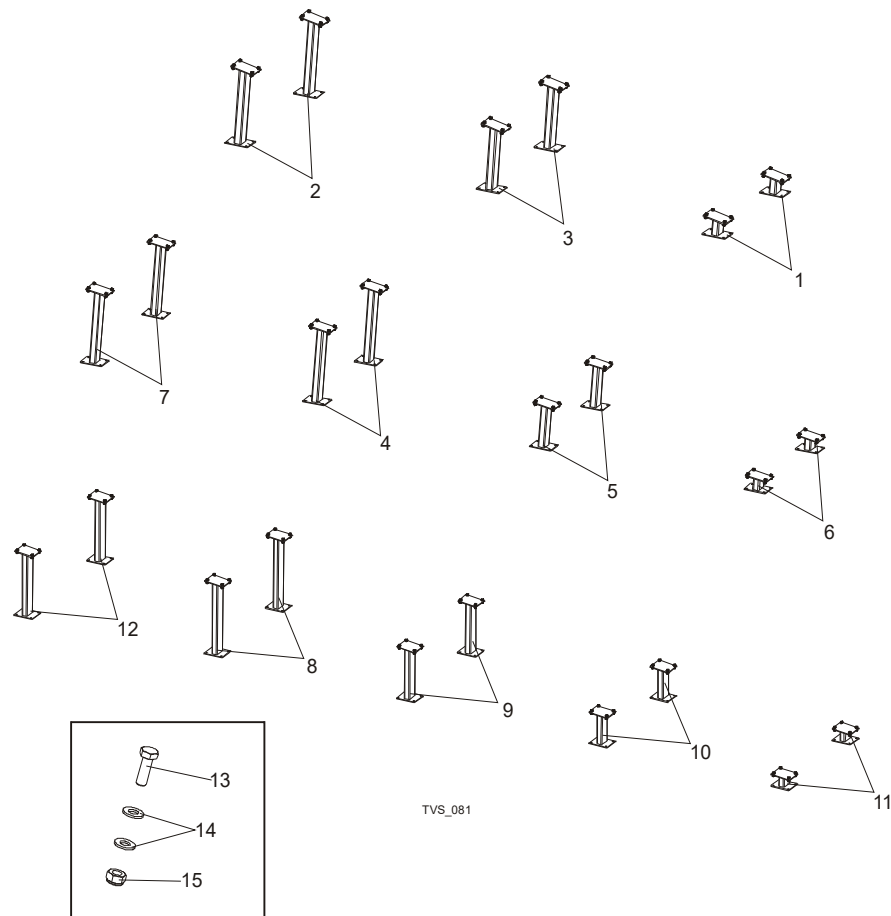

REF	PART #	DESCRIPTION	COMMENTS	QTY.
	099554	LEG KIT, CTD SHORT		1
1	099279-1	Leg, 7.6m Rear Ptd		2
2	099415-1	Leg, Front Ptd		2
3	099416-1	Leg, Rear Ptd		2
	099568	LEG KIT, CTD MEDIUM		1
4	099573-1	Leg, Ctd5.4 Middle Ptd (1)		2
5	099574-1	Leg, Ctd5.4 Middle Ptd (2)		2

REF	PART #	DESCRIPTION	COMMENTS	QTY.
6	099575-1	Leg, Ctd5.4 Rear Ptd		2
7	099576-1	Leg, Ctd5.4 Front Ptd		2
	099553	LEG KIT, CTD LONG		1
8	099277-1	Leg, Ctd7.2 Middle Ptd (1)		2
9	099278-1	Leg, Ctd7.2 Middle Ptd (2)		2
10	099562-1	Leg, Ctd7.2 Middle Ptd (3)		2
11	099564-1	Leg, Ctd7.2 Rear Ptd		2
12	099566-1	Leg, Ctd7.2 Front Ptd		2
13	F81003-2	BOLT, M10X30-5.8 HEX HEAD FULL THREAD ZINC		24/32/ 40
14	F81055-1	WASHER, 10.5 FLAT ZINC		48/64/ 80
15	F81033-1	NUT, M10-8-B HEX NYLON ZINC LOCK		24/32/ 40

7.6 Slabs Table

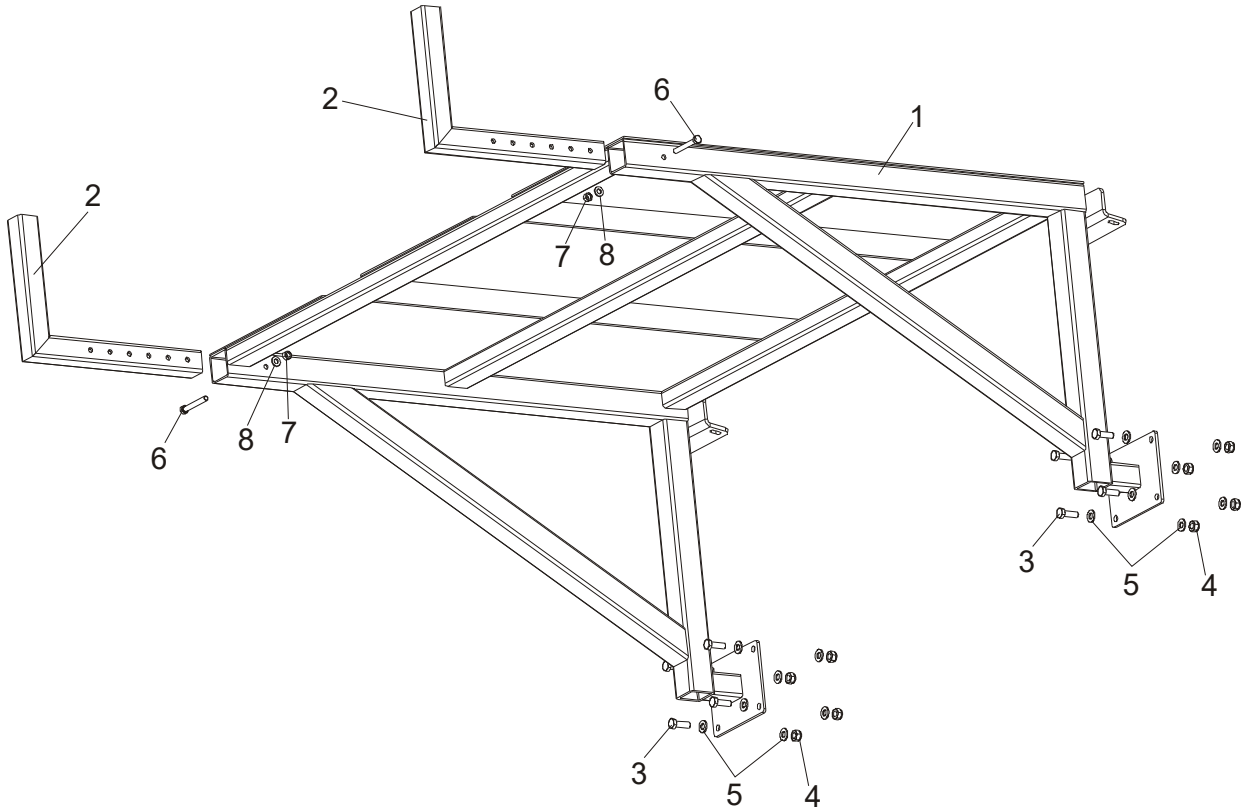

REF	PART #	DESCRIPTION	COMMENTS	QTY.
1	100517-1	TABLE, SLPCTD HIGH		1

7**Cross Transfer Deck***Slabs Table*

REF	PART #	DESCRIPTION	COMMENTS	QTY.
2	100531-1	ARM, TABLE LOCK		2
3	F81003-2	BOLT, M10X30-5.8 HEX HEAD FULL THREAT		8
4	F81033-1	NUT, M10-8-B NYLON HEX ZINC LOCK		16
5	F81055-1	WASHER, 10.5 FLAT ZINC		8
6	F81002-9	BOLT, M8X65 8.8 HEX HEAD ZINC		2
7	F81032-1	NUT, M8 HEXAGON, GRADE 5.8 FREE ZINC		2
8	F81054-1	WASHER, 8.4 FLAT ZINC		2

7.7 Decals

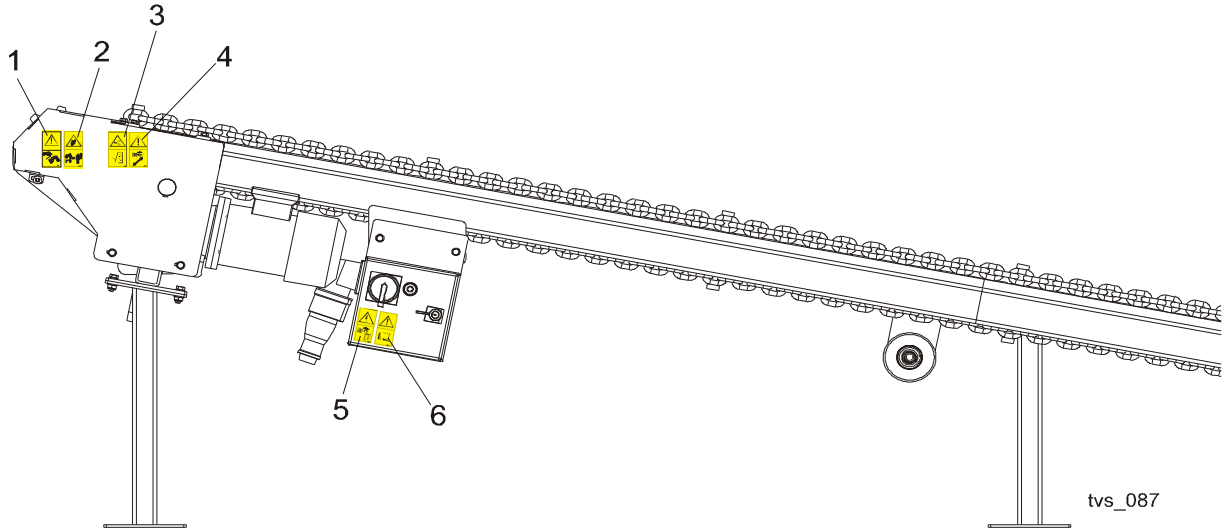

tvS_087

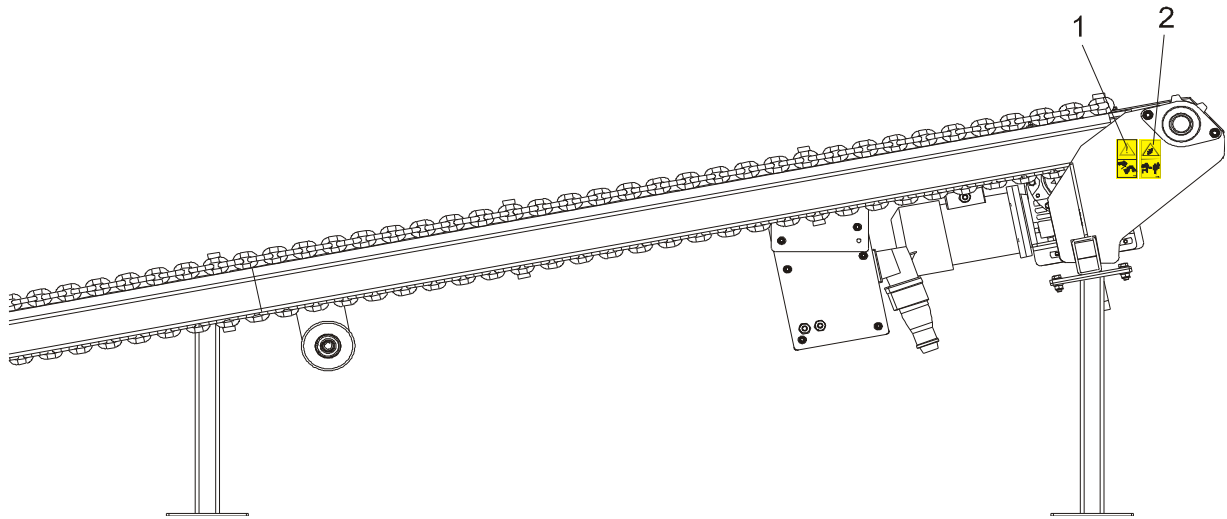

REF	PART #	DESCRIPTION	COMMENTS	QTY.
	099835	DECALS KIT, PICTOGRAMS, CROSS TRANSFER DECK		1
1	099780	Decal, Look Out For The Falling Slabs (Pictogram)		2
2	099221	Decay, Keep Away Warning (Pictogram),		2
3	099220	Decal, Close All Guards And Covers Before Starting The Machine		1

7 Cross Transfer Deck

Decals

REF	PART #	DESCRIPTION	COMMENTS	QTY.
4	098177	Decal, Disconnect And Lock Out Power Supply Before Servicing (Pictogram)		1
5	096314	Decal, Keep Away Warning (Pictogram)		2
6	099540	Decal, Gear Danger (Pictogram)		2