

## **APPENDIX A ELECTRICAL INFORMATION**

**EG300EC25U (U.S. Only)      Rev. B4.00+**

# Table of contents

WM\_TableOfContents

Page	Page type	Page description	Date	Edited by
/A1	Table of contents	Table of contents	6/14/2017	SDC
/B1	Overview	Revision History	6/14/2017	SDC
+ENC1/1	Schematic multi-line	Power Pg 1	6/14/2017	SDC
+ENC1/2	Schematic multi-line	Power Pg 2	6/12/2017	SDC
+ENC1/3	Schematic multi-line	Control Pg 1	6/12/2017	SDC
+ENC1/4	Schematic multi-line	Control Pg 2	6/12/2017	SDC
+ENC1/5	Schematic multi-line	Control Pg 3	6/14/2017	SDC
+ENC1/6	Schematic multi-line	Control Pg 4	6/12/2017	SDC
+ENC2/7	Schematic multi-line	PLC Pg 1	6/12/2017	SDC
+ENC2/8	Schematic multi-line	PLC Pg 2	6/14/2017	SDC
+ENC2/9	Schematic multi-line	PLC Pg 3	6/12/2017	SDC
+Docs/C1	Parts list	Parts list	6/14/2017	SDC
+Docs/D1	Terminal line-up diagram	Terminal line-up diagram	6/14/2017	SDC
+Docs/D2	Terminal line-up diagram	Terminal line-up diagram	6/14/2017	SDC
+Docs/D3	Terminal line-up diagram	Terminal line-up diagram	6/14/2017	SDC
+Docs/D4	Terminal line-up diagram	Terminal line-up diagram	6/14/2017	SDC
+Docs/D5	Terminal line-up diagram	Terminal line-up diagram	6/14/2017	SDC
+Docs/E1	Cable overview	Cable overview	6/14/2017	SDC
+Docs/F1	Panel layout	Main Control Layout	6/14/2017	SDC
+Docs/F2	Panel layout	Main Control Insert Layout	6/14/2017	SDC
+Docs/F3	Panel layout	Operator Face Layout	6/14/2017	SDC
+Docs/F4	Panel layout	Operator Cable Layout	6/14/2017	SDC
+Docs/F5	Panel layout	Machine Layout Front	6/14/2017	SDC
+Docs/F6	Panel layout	Machine Layout Left	6/14/2017	SDC
+Docs/F7	Panel layout	Machine Layout Top	6/14/2017	SDC
+Mfg_Docs/G1	Parts list	Mfg. Parts List	6/14/2017	SDC
+Mfg_Docs/H1	Cable overview	Mfg. Cable Overview	6/14/2017	SDC

EG3007

		<b>Wood-Mizer®</b>	
Project Description: EG300EC25U			
Revision:	B4.00	Pg Desc: Table of contents	
Mounting Location: +		Type: Table of contents	
Prev. pg:	Page: A1	Next pg: B1	Total Pgs: 27

# Revision History

Date	Revision	Revision Record	Drawn By	Checked By
11/18/16	B3.00	Power Supply Change, Setworks PLC Change	JRF	SDC
06/05/17	B4.00	Changed U1 & U2 to Altivar 320 Series from Altivar 312 Series. CBL2 & CBL3 Changed due to Altivar Grounding Termination.	SDC	JRF

 <b>Wood-Mizer®</b>	
Project Description: EG300EC25U	
Revision:	B4.00 Pg Desc: Revision History
Mounting Location: +	Type: Overview
Prev. pg: A1	Page: B1 Next pg: +ENC1/1 Total Pgs: 27

# Wood-Mizer®

Voltage	480VAC +4/-10%
Phase	3Ph
Frequency	60 Hz
FLA Machine	42.5A
FLA Largest Load	34A
Wiring Diagram	907EU
SCCR	5kA

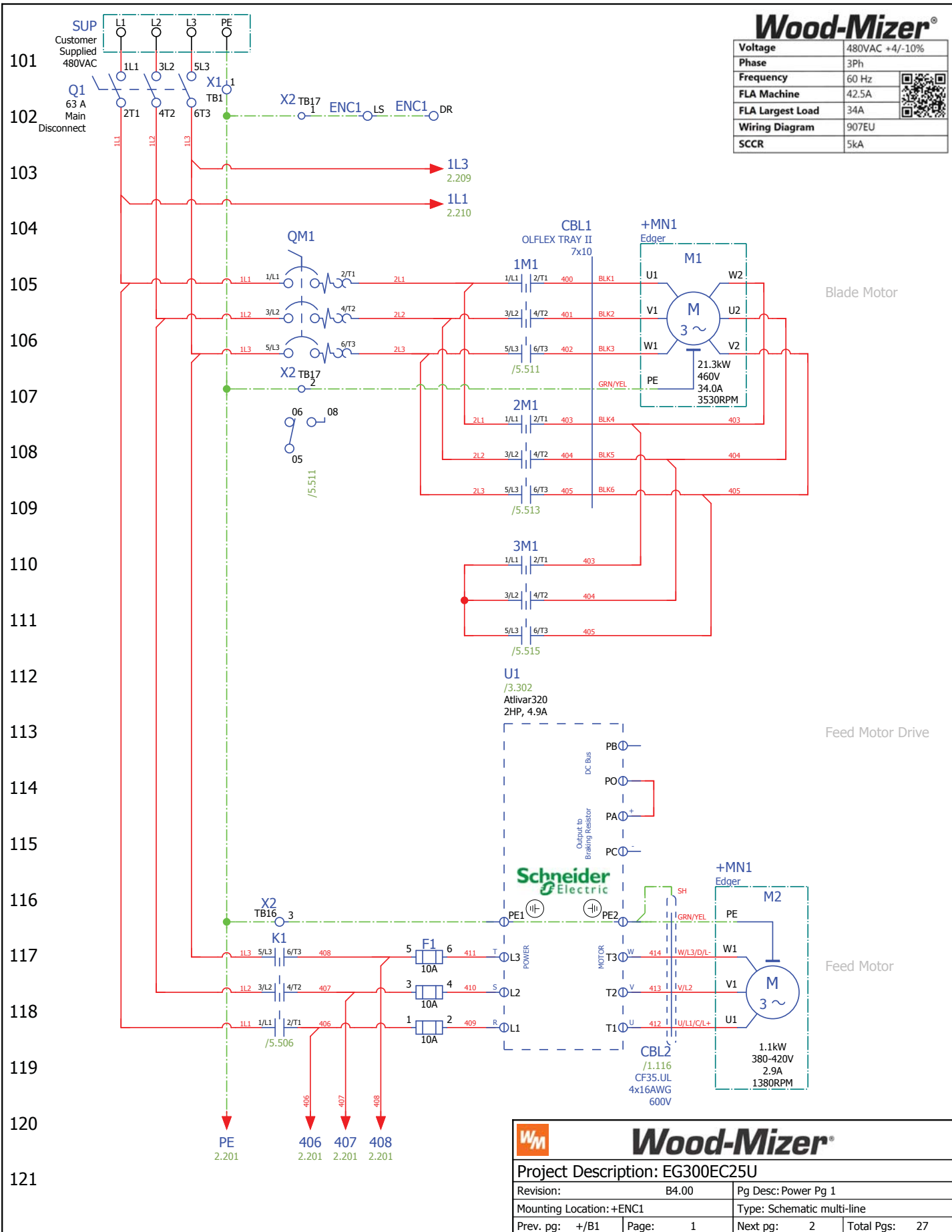

Blade Motor

Feed Motor Drive

Feed Motor

## Wood-Mizer®

Project Description: EG300EC25U

Revision: B4.00	Pg Desc: Power Pg 1
Mounting Location: +ENC1	Type: Schematic multi-line
Prev. pg: +/B1	Page: 1
Next pg: 2	Total Pgs: 27

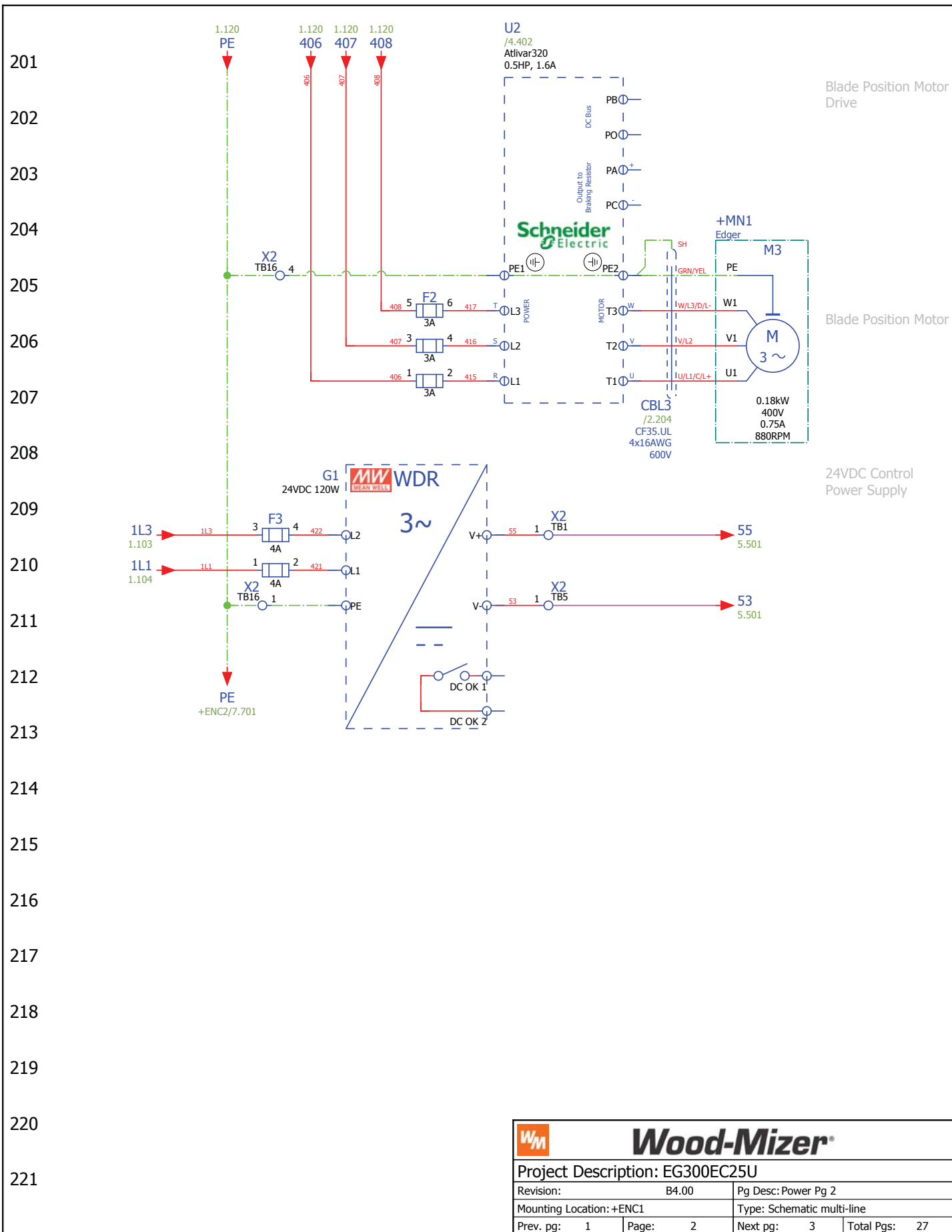

301  
302  
303  
304  
305  
306  
307  
308  
309  
310  
311  
312  
313  
314  
315  
316  
317  
318  
319  
320  
321

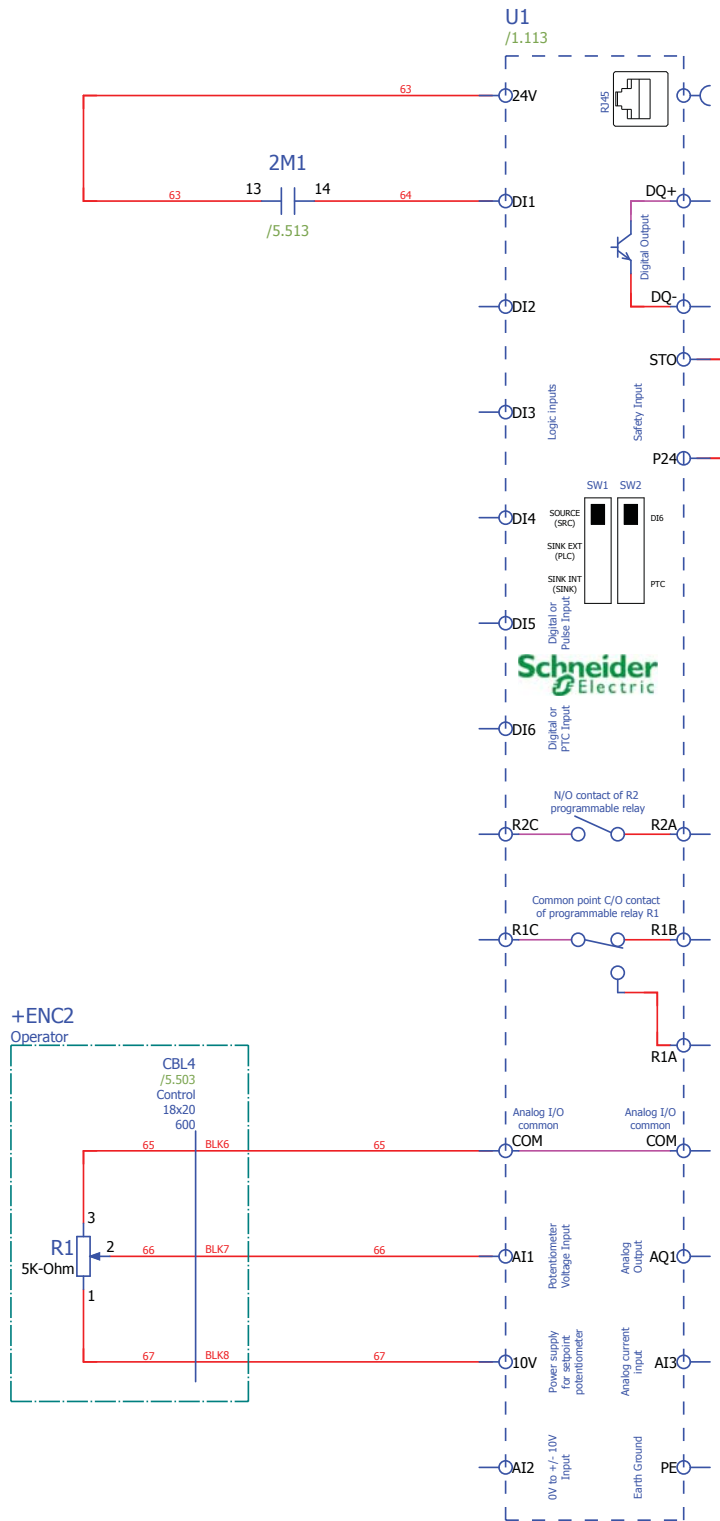

Feed Forward Control

Feed Speed Potentiometer

		<b>Wood-Mizer®</b>	
Project Description: EG300EC25U			
Revision:	B4.00	Pg Desc: Control Pg 1	
Mounting Location:	+ENC1	Type: Schematic multi-line	
Prev. pg:	2	Page:	3
		Next pg:	4
		Total Pgs:	27

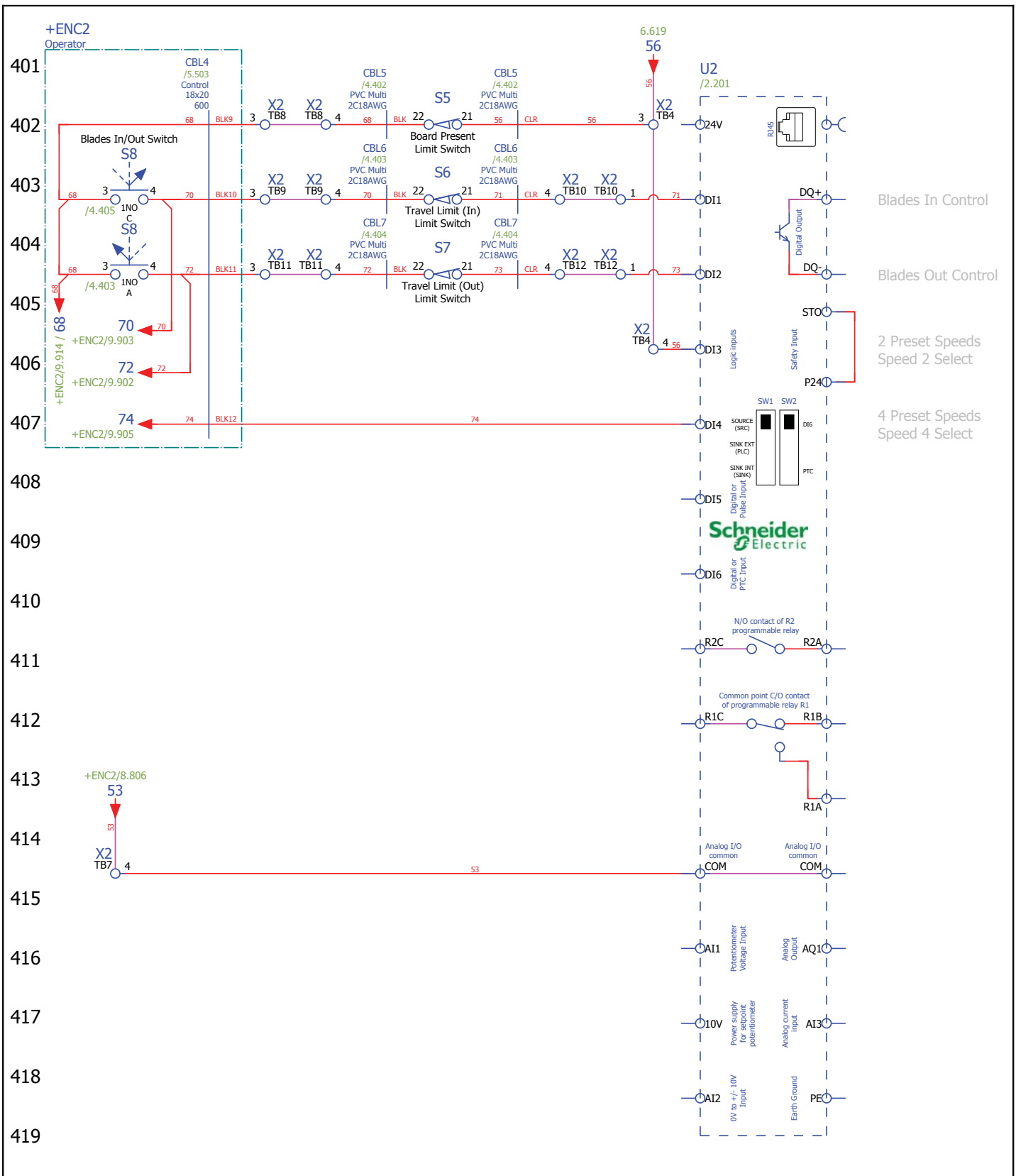

<b>Wood-Mizer®</b>	
Project Description: EG300EC25U	
Revision:	B4.00 Pg Desc: Control Pg 2
Mounting Location: +ENC1	Type: Schematic multi-line
Prev. pg: 3	Page: 4 Next pg: 5 Total Pgs: 27

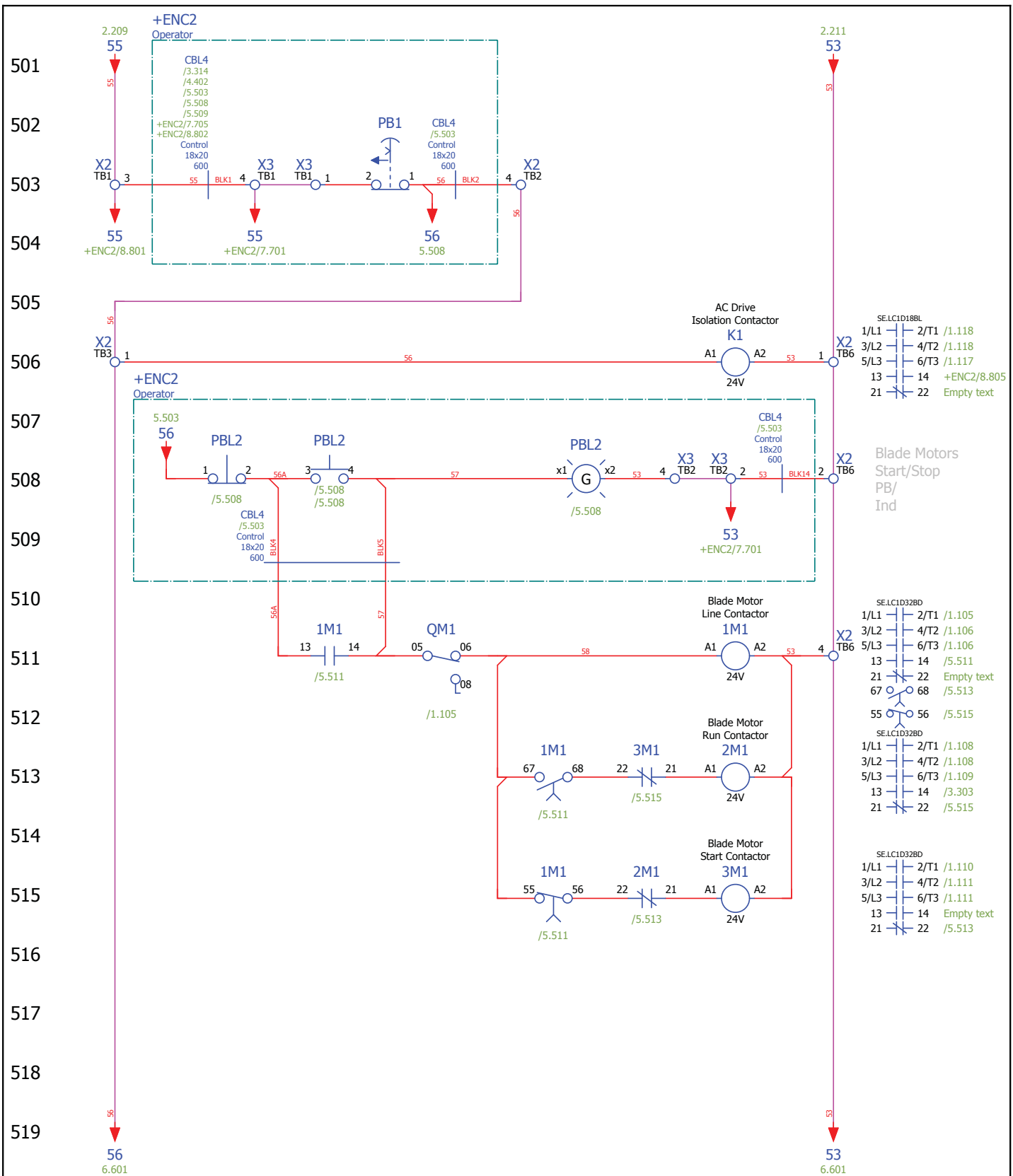

- SE.LC1D18BL
- 1/L1 2/T1 /1.118
  - 3/L2 4/T2 /1.118
  - 5/L3 6/T3 /1.117
  - 13 14 +ENC2/8.805
  - 21 22 Empty text

Blade Motors  
Start/Stop  
PB/  
Ind

- SE.LC1D32BD
- 1/L1 2/T1 /1.105
  - 3/L2 4/T2 /1.106
  - 5/L3 6/T3 /1.106
  - 13 14 /5.511
  - 21 22 Empty text
  - 67 68 /5.513
  - 55 56 /5.515

- SE.LC1D32BD
- 1/L1 2/T1 /1.108
  - 3/L2 4/T2 /1.108
  - 5/L3 6/T3 /1.109
  - 13 14 /3.303
  - 21 22 /5.515

- SE.LC1D32BD
- 1/L1 2/T1 /1.110
  - 3/L2 4/T2 /1.111
  - 5/L3 6/T3 /1.111
  - 13 14 Empty text
  - 21 22 /5.513

<b>Wood-Mizer®</b>	
Project Description: EG300EC25U	
Revision: B4.00	Pg Desc: Control Pg 3
Mounting Location: +ENC1	Type: Schematic multi-line
Prev. pg: 4	Page: 5
Next pg: 6	Total Pgs: 27



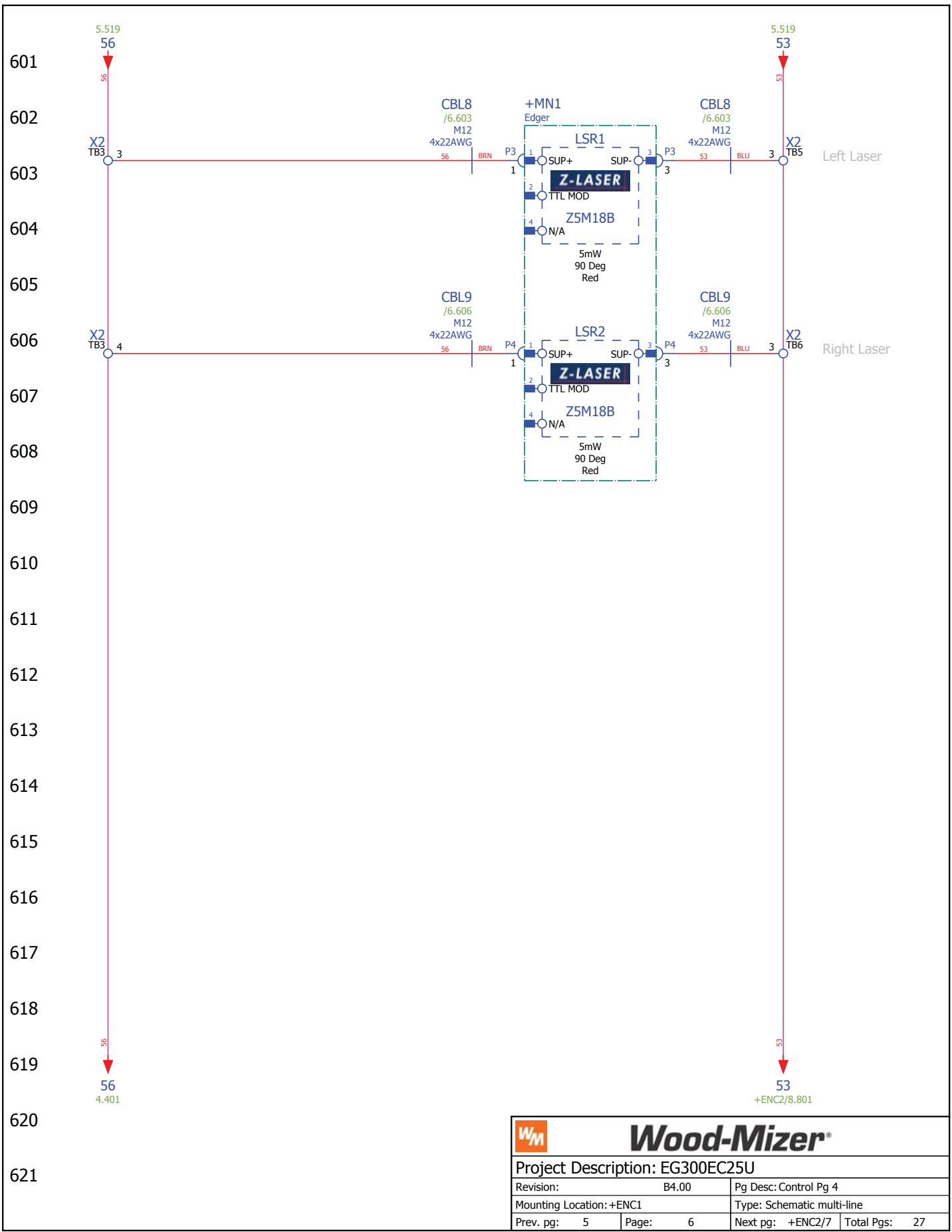

601  
602  
603  
604  
605  
606  
607  
608  
609  
610  
611  
612  
613  
614  
615  
616  
617  
618  
619  
620  
621

		<b>Wood-Mizer®</b>	
Project Description: EG300EC25U			
Revision:	B4.00	Pg Desc: Control Pg 4	
Mounting Location:	+ENC1	Type: Schematic multi-line	
Prev. pg:	5	Page:	6
Next pg:	+ENC2/7	Total Pgs:	27

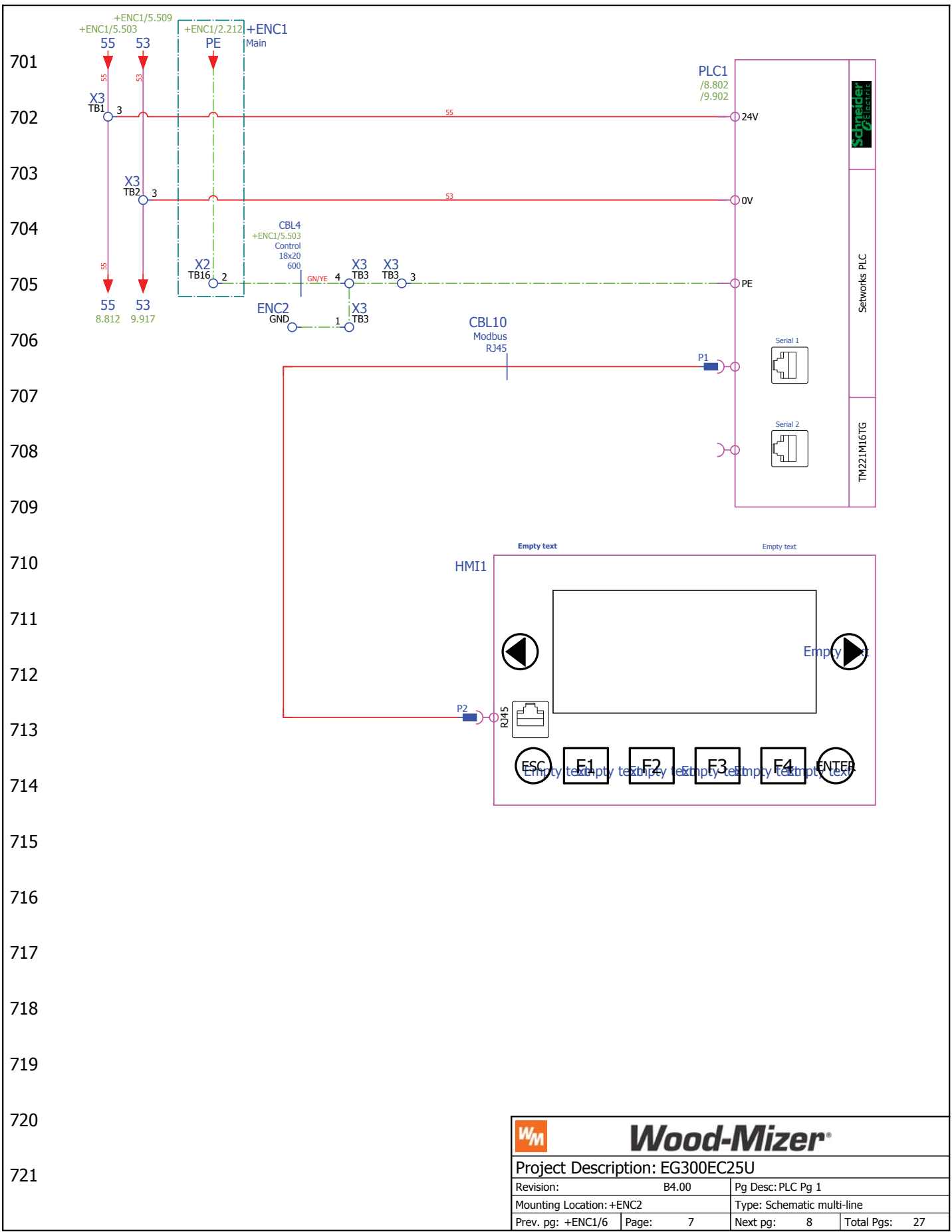

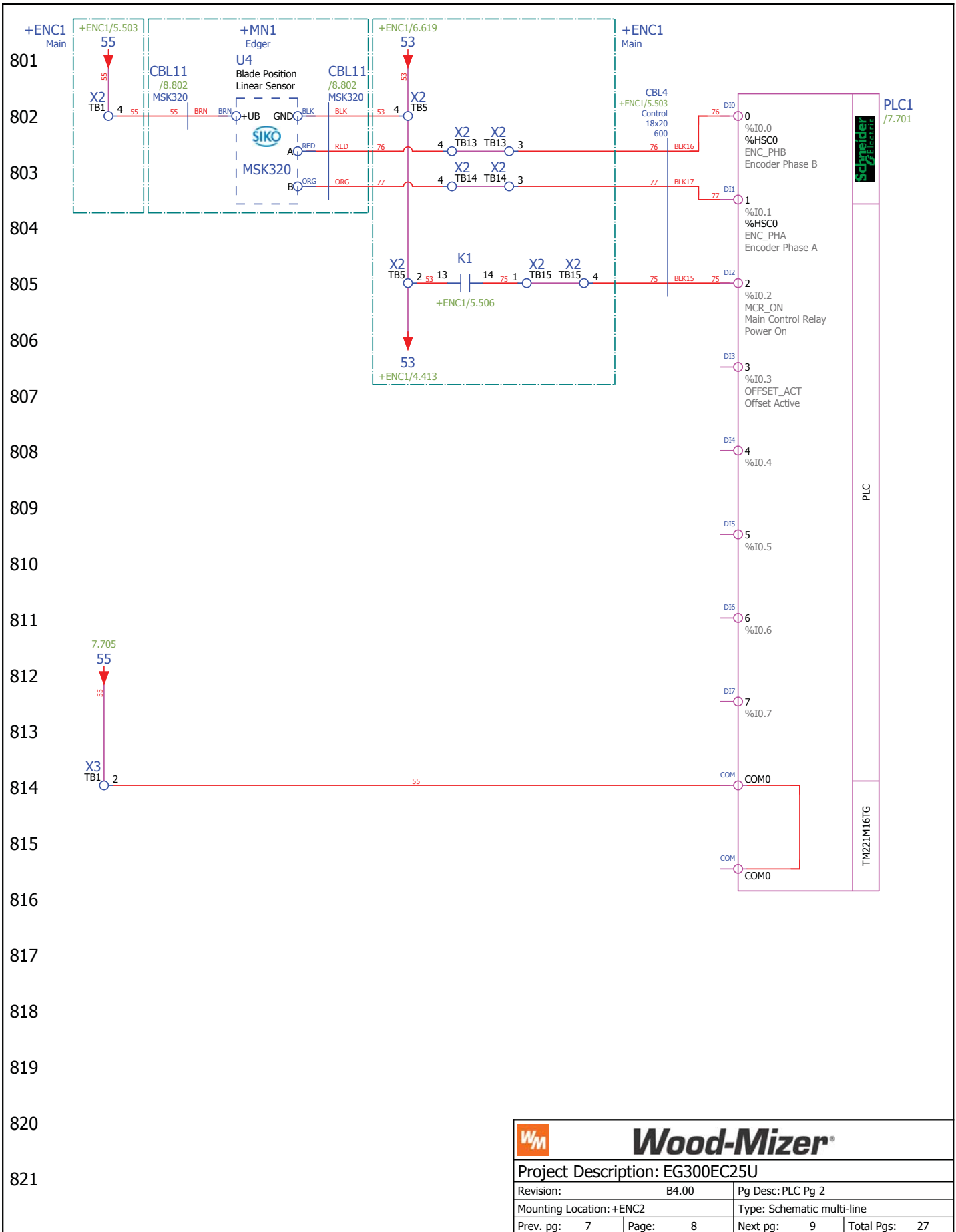

901  
902  
903  
904  
905  
906  
907  
908  
909  
910  
911  
912  
913  
914  
915  
916  
917  
918  
919  
920  
921

PLC1  
/7.701

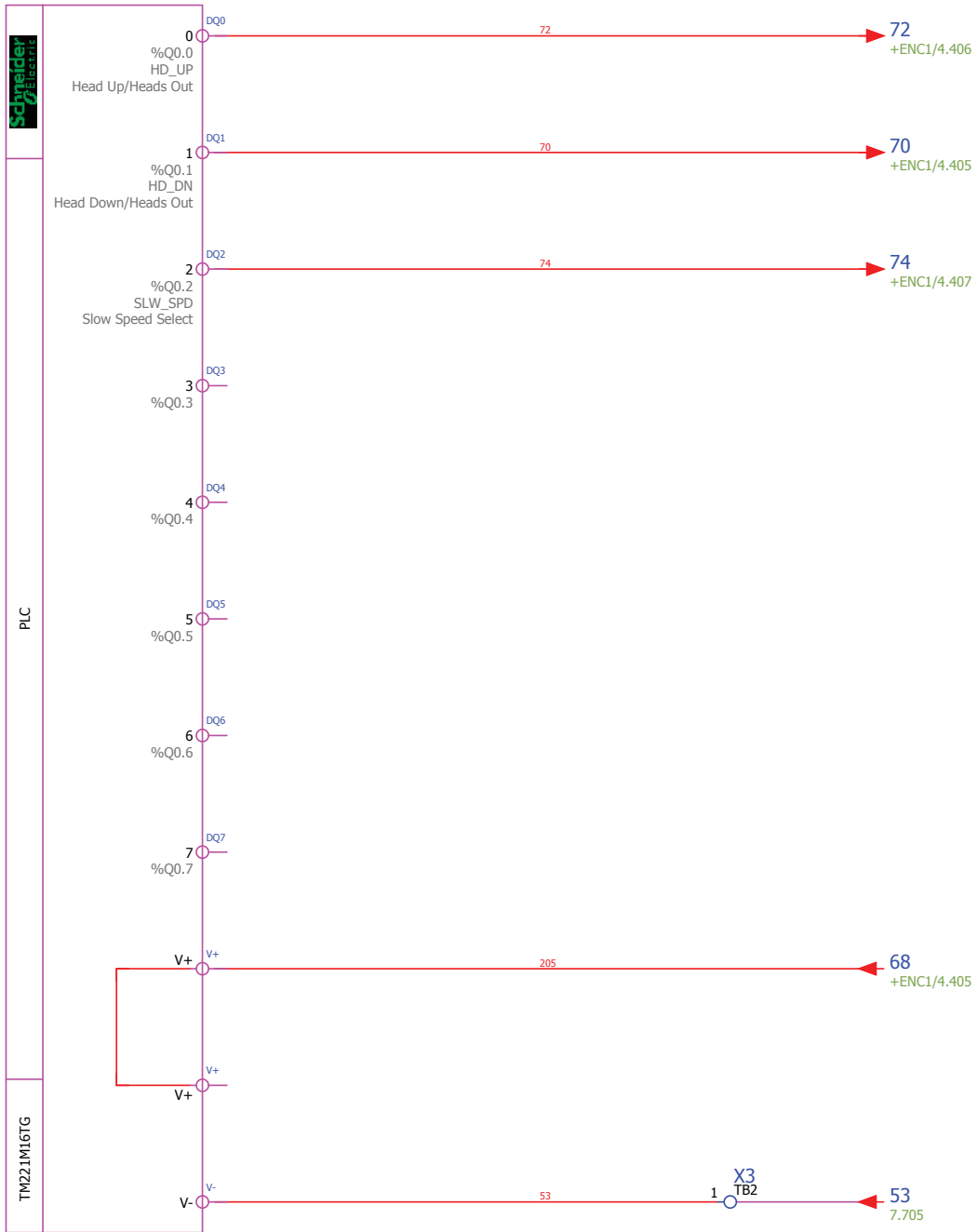

		<b>Wood-Mizer®</b>	
Project Description: EG300EC25U			
Revision:	B4.00	Pg Desc: PLC Pg 3	
Mounting Location:	+ENC2	Type: Schematic multi-line	
Prev. pg:	8	Page:	9
Next pg: +Docs/C1		Total Pgs: 27	

# Device Tag/Parts List

WM\_PARTS\_LIST-Manual

Device tag	Function	Wood-Mizer Part Number	Wood-Mizer Description	Qty.	X-Ref
1M1	Blade Motor Line Contactor	052465	Contactora, 32A 3P 24VDC Coil	1	+ENC1/5.511
1M1	=	078372	Contactora, Wye-Delta Assy Kit D09-12	1	+ENC1/5.511
2M1	Blade Motor Run Contactor	052465	Contactora, 32A 3P 24VDC Coil	1	+ENC1/5.513
3M1	Blade Motor Start Contactor	052465	Contactora, 32A 3P 24VDC Coil	1	+ENC1/5.515
ENC1		068090	Enclosure, EG300EC25U Control	1	+ENC1/1
F1	Feed Motor Drive Fuses	068067	Fuse Holder, 3P Class CC Wire Clamp	1	+ENC1/1.117
F1	=	051957	Fuse, 10A 600V Class CC Delay	3	+ENC1/1.117
F2	Blade Position Motor Drive Fuses	068067	Fuse Holder, 3P Class CC Wire Clamp	1	+ENC1/2.205
F2	=	052793	Class CC Fuse 3 A	3	+ENC1/2.205
F3	24VDC Power Supply Fuses	068066	Fuse Holder, 2P Class CC Wire Clamps	1	+ENC1/2.209
F3	=	052713	Fuse, 4A 600V Calss CC Delay	2	+ENC1/2.209
G1	24VDC Power Supply	068242	Power Supply, 24VDC 5A 200-500V	1	+ENC1/2.208
HMI1	Setworks Text Display	069850-2	HMI Assy, PLC Setworks	1	+ENC2/7.710
K1	AC Drive Isolation Contactor	024911	Contactora, 18A 3P 24VDC Low Pwr Coil	1	+ENC1/5.506
LSR1	Left Laser	069855	Laser, 5mW 532nm 90 Deg Line Z-Laser	1	+ENC1/6.603
LSR2	Right Laser	069855	Laser, 5mW 532nm 90 Deg Line Z-Laser	1	+ENC1/6.606
M1	Blade Motor	085519	Motor, 21.3 kW 28.6 HP 3ph 50/60Hz	1	+ENC1/1.105
M2	Feed Motor	098663	MOTOR MR-80/64 / 1.1-1400 / K3 / V6	1	+ENC1/1.117
M3	Head Position Motor	101024	MOTOR MR-50/78/0.18-900 K3/B8-EDGER	1	+ENC1/2.205
PB1	E-Stop Push-Button	068950	Collar, Mount 1NC ZB5	1	+ENC1/5.503
PB1	=	068940	Pushbutton Head, 22mm E-Stop Twist-Pull	1	+ENC1/5.503
PB1	=	050992	Legend, E-Stop, Round Yellow	1	+ENC1/5.503
PBL2	Blade Motors Start/Stop PB/ Ind	068952	Collar, Mount 1NO ZB5	1	+ENC1/5.508
PBL2	=	068921	Contact Block, NC ZB5	1	+ENC1/5.508
PBL2	=	068910	Light Module, Green ZB5	1	+ENC1/5.508
PBL2	=	068909	Push-Button, Grn/Red Flush Illuminated	1	+ENC1/5.508
PLC1	Setworks PLC	069849-3	PLC Ass, PLC Setworks	1	+ENC2/7.701
Q1	Main Disconnect	050881-1	Disconnect, 63A 600V 3P 6mm Shaft	1	+ENC1/1.102
Q1	=	051673-1	Shaft, Disconnect 180mmx6mm	1	+ENC1/1.102
Q1	=	050883-1	Handle, Disconnect RED/YEL 6mm Shaft	1	+ENC1/1.102
QM1	Blade Motor Motor Protector	073503	Motor Starter, GV3P50 37-50A 3P	1	+ENC1/1.105
QM1	=	073509	Auxiliary Contact, GVAM11 Short Circuit	1	+ENC1/1.105
R1	Feed Speed Control	068077	Potentiometer, 5K-Ohm 22mm	1	+ENC1/3.316
S5	Board Present Limit Switch	100910	Switch, TVS Travel Limit	1	+ENC1/4.402
S6	Travel Limit (In) Limit Switch	086469	Switch, GLCB01A2B Limit	1	+ENC1/4.403
S7	Travel Limit (Out) Limit Switch	086469	Switch, GLCB01A2B Limit	1	+ENC1/4.405
S8	Blades In/Out Switch	068952	Collar, Mount 1NO ZB5	1	+ENC1/4.403
S8	=	068920	Contact Block, NO ZB5	1	+ENC1/4.403
S8	=	073511	Selector Switch Head, 3 Pos Spring Return	1	+ENC1/4.403
U1	Feed Motor Drive	068174-2	Drive Assy, EG300EC25U Feed	1	+ENC1/1.113
U2	Blade Position Motor Drive	068175-2	Drive Assy, EG300EC25U Blade Position	1	+ENC1/2.201
U4	Blade Position Linear Sensor	096014	Sensor Assembly, MSK-320	1	+ENC2/8.802

# Terminal line-up diagram

Wood-Mizer\_Terminal\_Lineup\_Diagram

Terminal strip +ENC1-ENC1								
Terminal				Jumper		End Plate	Remark	Terminal X-Ref
Ref. Des.	Level	P/N	Description	Diagram	P/N	P/N		
DR								/1.02
LS								/1.02

		<b>Wood-Mizer®</b>		
Project Description: EG300EC25U				
Revision:		B4.00	Pg Desc: Terminal line-up diagram	
Mounting Location: +Docs			Type: Terminal line-up diagram	
Prev. pg:	C1	Page:	D1	Next pg: D2 Total Pgs: 27

# Terminal line-up diagram

Wood-Mizer\_Terminal\_Lineup\_Diagram

## Terminal strip +ENC1-X1

Terminal				Jumper		End Plate	Remark	Terminal X-Ref
Ref. Des.	Level	P/N	Description	Diagram	P/N	P/N		
TB1		068111	Terminal Block, 2 Pos 16mm GND Clamp			068112		/1.02

		<b>Wood-Mizer®</b>	
Project Description: EG300EC25U			
Revision:	B4.00	Pg Desc: Terminal line-up diagram	
Mounting Location: +Docs		Type: Terminal line-up diagram	
Prev. pg:	D1	Page:	D2
Next pg:	D3	Total Pgs:	27

# Terminal line-up diagram

Wood-Mizer\_Terminal\_Lineup\_Diagram

Terminal strip +ENC1-X2								
Terminal				Jumper		End Plate	Remark	Terminal X-Ref
Ref. Des.	Level	P/N	Description	Diagram	P/N	P/N		
TB1		068103	Terminal Block, 4Pos 1.5mm Com Clamp					/2.09
TB2		068103	Terminal Block, 4Pos 1.5mm Com Clamp	●	068113		Jumper Is Trimmed Down To 2 Position Jumper Between TB2-3	/5.03
TB3		068103	Terminal Block, 4Pos 1.5mm Com Clamp	●				/5.06
TB4		068103	Terminal Block, 4Pos 1.5mm Com Clamp	●				/4.06
TB5		068103	Terminal Block, 4Pos 1.5mm Com Clamp	●	068113		Jumper Is Trimmed Down To 2 Position Jumper Between TB4-5	/2.11
TB6		068103	Terminal Block, 4Pos 1.5mm Com Clamp	●				/5.06
TB7		068103	Terminal Block, 4Pos 1.5mm Com Clamp	●				/4.15
TB8		068103	Terminal Block, 4Pos 1.5mm Com Clamp					/4.02
TB9		068103	Terminal Block, 4Pos 1.5mm Com Clamp					/4.03
TB10		068103	Terminal Block, 4Pos 1.5mm Com Clamp					/4.03
TB11		068103	Terminal Block, 4Pos 1.5mm Com Clamp					/4.05
TB12		068103	Terminal Block, 4Pos 1.5mm Com Clamp					/4.05
TB13		068103	Terminal Block, 4Pos 1.5mm Com Clamp					+ENC2/8.03
TB14		068103	Terminal Block, 4Pos 1.5mm Com Clamp					+ENC2/8.03
TB15		068103	Terminal Block, 4Pos 1.5mm Com Clamp			068105		+ENC2/8.05
TB16		068104	Terminal Block, 4Pos 1.5mm GND Clamp			068105		/1.16
TB17		068107	Terminal Block, 2Pos 4mm GND Clamp			068108		/1.02

		<b>Wood-Mizer®</b>	
Project Description: EG300EC25U			
Revision:	B4.00	Pg Desc: Terminal line-up diagram	
Mounting Location: +Docs		Type: Terminal line-up diagram	
Prev. pg:	D2	Page:	D3
Next pg:	D4	Total Pgs:	27



# Terminal line-up diagram

Wood-Mizer\_Terminal\_Lineup\_Diagram

**Terminal strip +ENC2-ENC2**

Terminal				Jumper		End Plate	Remark	Terminal X-Ref
Ref. Des.	Level	P/N	Description	Diagram	P/N	P/N		
GND								/7.06

		<b>Wood-Mizer®</b>	
Project Description: EG300EC25U			
Revision:	B4.00	Pg Desc: Terminal line-up diagram	
Mounting Location: +Docs		Type: Terminal line-up diagram	
Prev. pg:	D3	Page:	D4
Next pg:	D5	Total Pgs:	27

# Terminal line-up diagram

Wood-Mizer\_Terminal\_Lineup\_Diagram

Terminal strip +ENC2-X3								
Terminal				Jumper		End Plate	Remark	Terminal X-Ref
Ref. Des.	Level	P/N	Description	Diagram	P/N	P/N		
TB1		068103	Terminal Block, 4Pos 1.5mm Com Clamp	•				+ENC1/5.03
TB2		068103	Terminal Block, 4Pos 1.5mm Com Clamp	•		068105		+ENC1/5.08
TB3		068104	Terminal Block, 4Pos 1.5mm GND Clamp	•		068105		/7.05

		<b>Wood-Mizer®</b>	
Project Description: EG300EC25U			
Revision:	B4.00	Pg Desc: Terminal line-up diagram	
Mounting Location: +Docs		Type: Terminal line-up diagram	
Prev. pg:	D4	Page:	D5
Next pg:	E1	Total Pgs:	27

# Cable Overview

Wood-Mizer\_Cable\_Overview

Cable Designation	Cable Part Number	Cable Description	Cable X-Ref
CBL1	078413	Cable Assy, Edger Blade Motor	+ENC1/1.105
CBL2	078414-1	Cable Assy, Edger Feed Motor	+ENC1/1.118
CBL3	078415-1	Cable Assy, Edger Blade Position Motor	+ENC1/2.207
CBL4	078416	Cable Assy, Edger Operator	+ENC1/5.503
CBL5	078417	Cable Assy, Edger Board Switch	+ENC1/4.402
CBL6	078418	Cable Assy, Edger Blades In Switch	+ENC1/4.403
CBL7	078419	Cable Assy, Edger Blades Out Switch	+ENC1/4.404
CBL8	078420	Cable Assy, Edger Laser Left	+ENC1/6.603
CBL9	078421	Cable Assy, Edger Laser Right	+ENC1/6.606
CBL10	078423	Cable Assy, Edger Modbus Comms	+ENC2/7.706
CBL11	096014	Sensor Assy, MSK320 (Integrated Into Sensor)	+ENC2/8.802

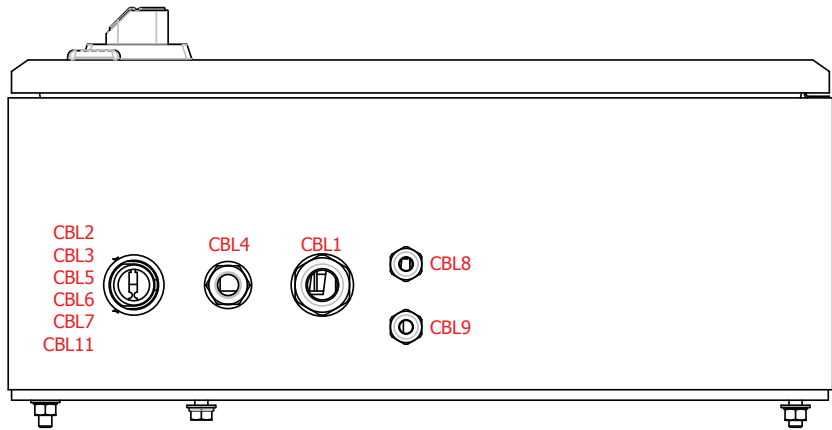
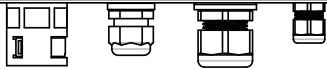
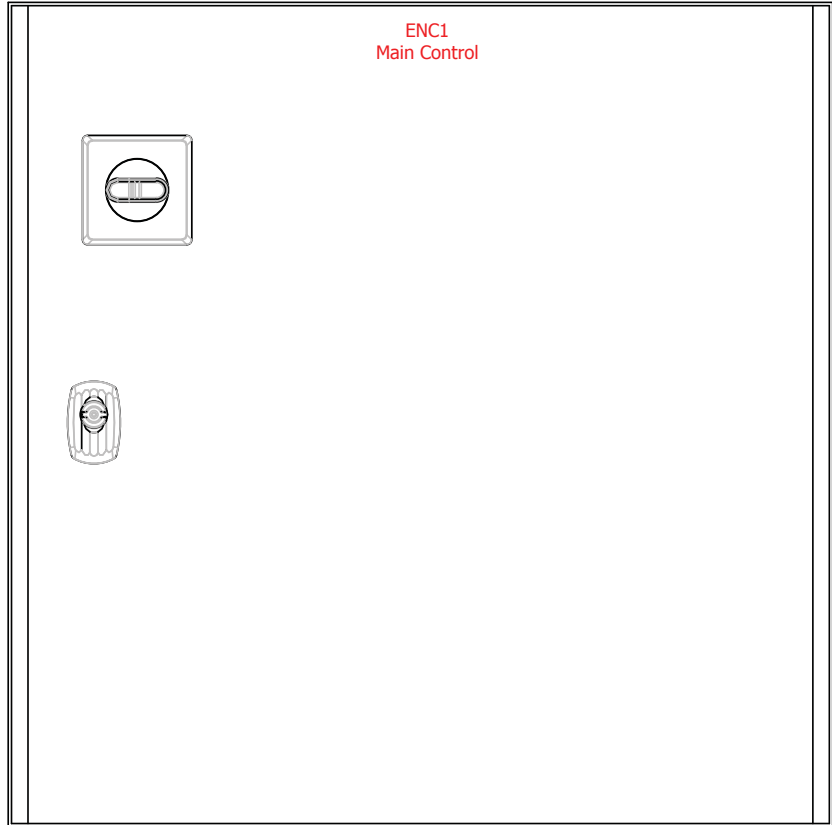

		<b>Wood-Mizer®</b>	
Project Description: EG300EC25U			
Revision:	B4.00	Pg Desc: Main Control Layout	
Mounting Location: +Docs		Type: Panel layout	
Prev. pg:	E1	Page:	F1
Next pg:		F2	Total Pgs: 27

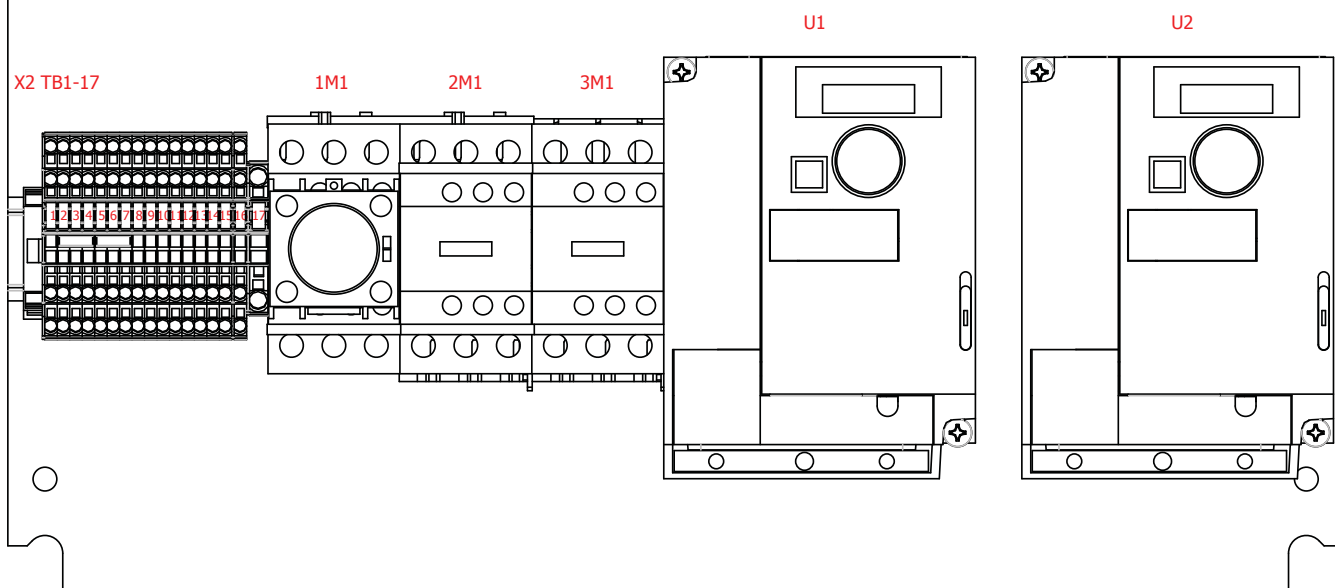
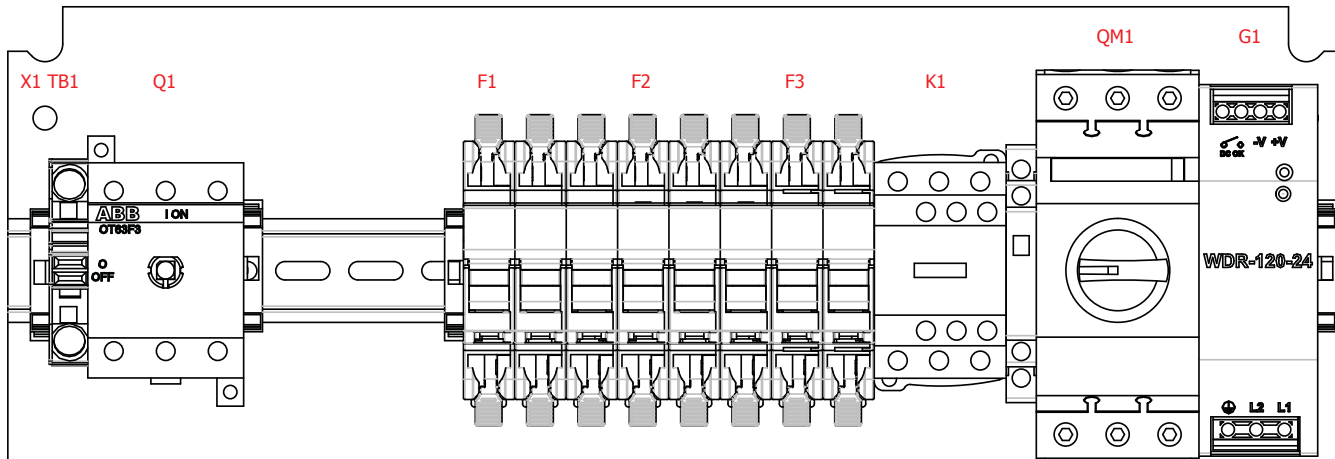

		<b>Wood-Mizer®</b>	
Project Description: EG300EC25U			
Revision:	B4.00	Pg Desc: Main Control Insert Layout	
Mounting Location:	+Docs	Type: Panel layout	
Prev. pg:	F1	Page:	F2
		Next pg:	F3
		Total Pgs:	27

HMI1

PB1

PBL2

S8

R1

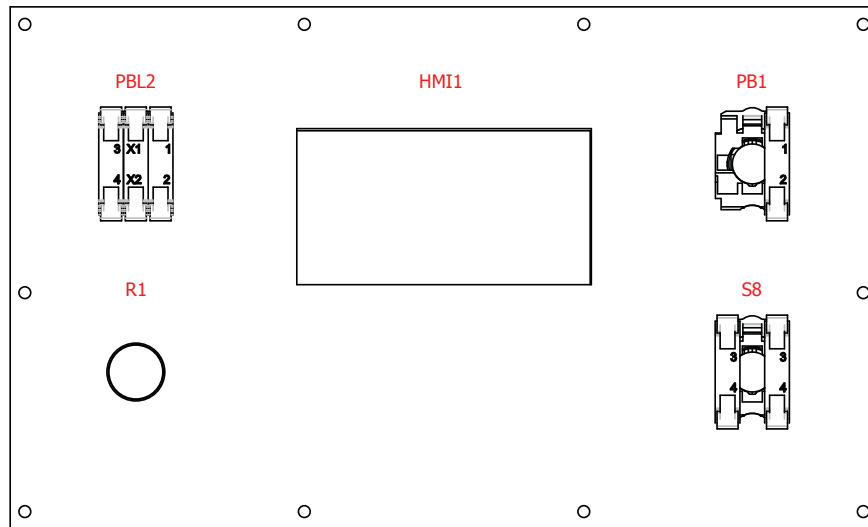

**Wood-Mizer®**

Project Description: EG300EC25U

Revision: B4.00 Pg Desc: Operator Face Layout

Mounting Location: +Docs Type: Panel layout

Prev. pg: F2 Page: F3 Next pg: F4 Total Pgs: 27

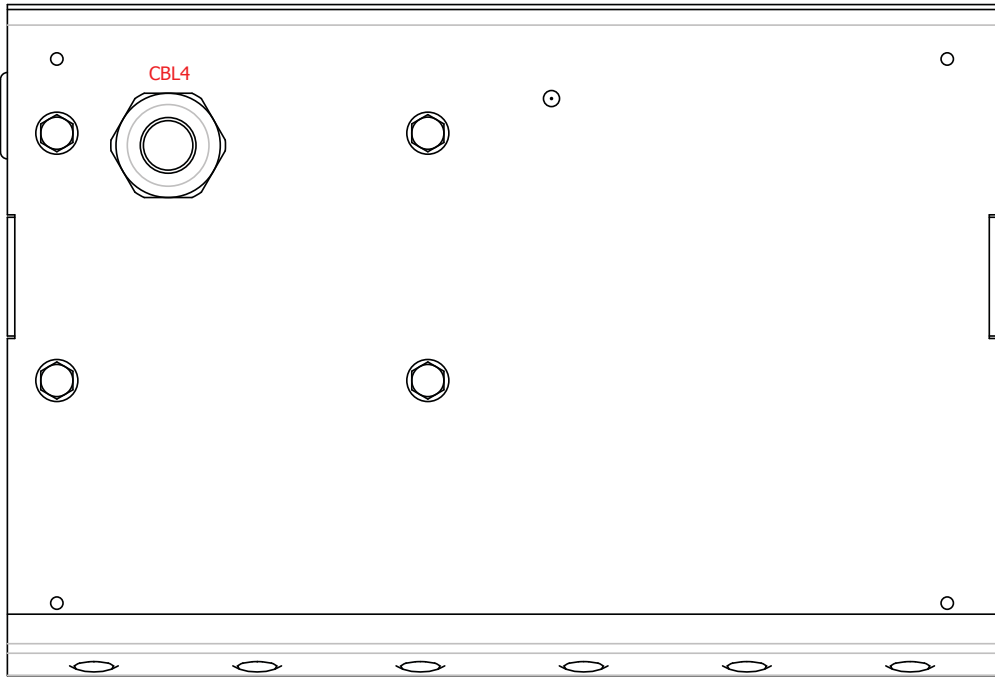

**Wood-Mizer®**

Project Description: EG300EC25U

Revision: B4.00 Pg Desc: Operator Cable Layout

Mounting Location: +Docs Type: Panel layout

Prev. pg: F3 Page: F4 Next pg: F5 Total Pgs: 27

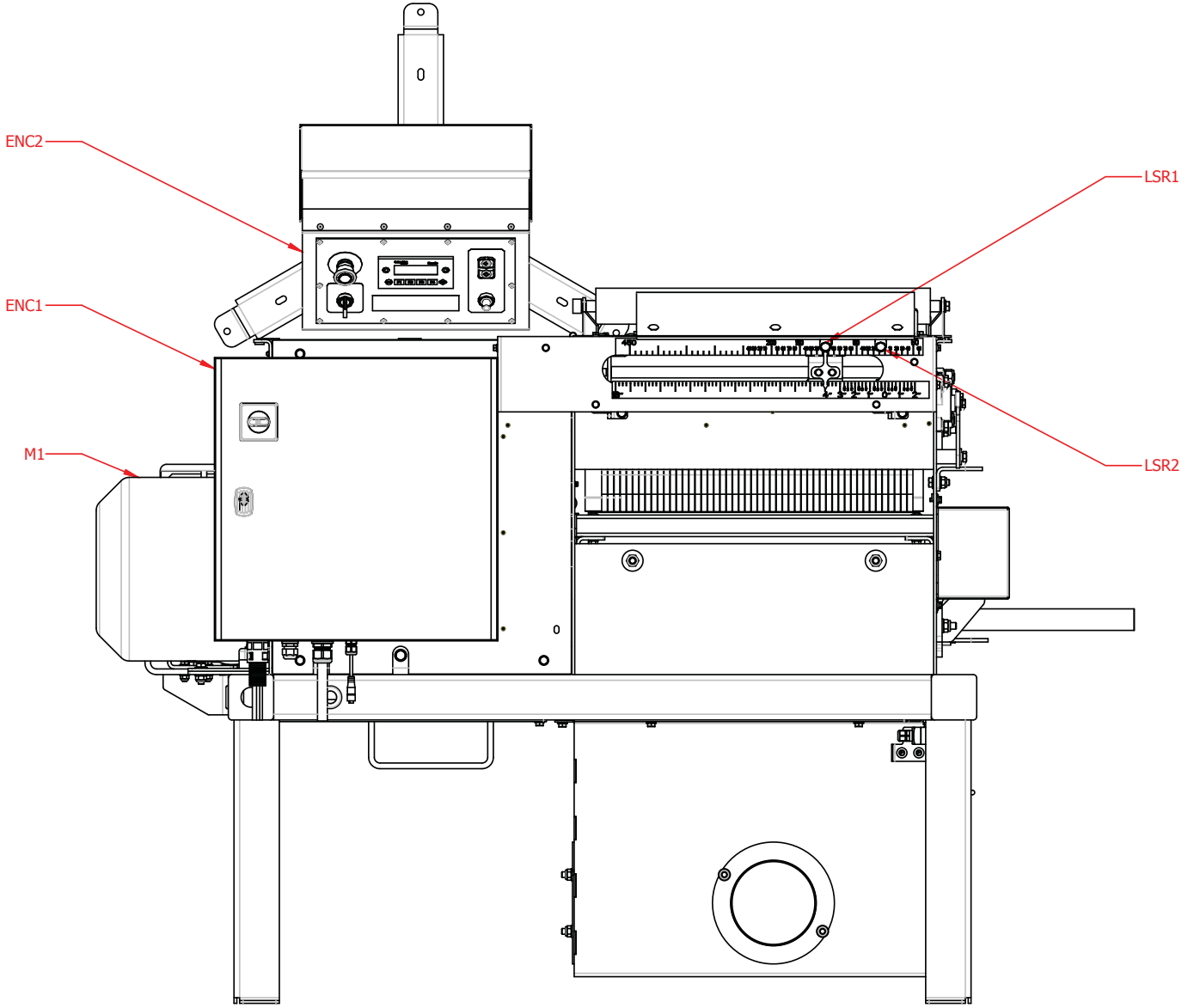



		<b>Wood-Mizer®</b>	
Project Description: EG300EC25U			
Revision:	B4.00	Pg Desc: Machine Layout Front	
Mounting Location:	+Docs	Type: Panel layout	
Prev. pg:	F4	Page:	F5
		Next pg:	F6
		Total Pgs:	27

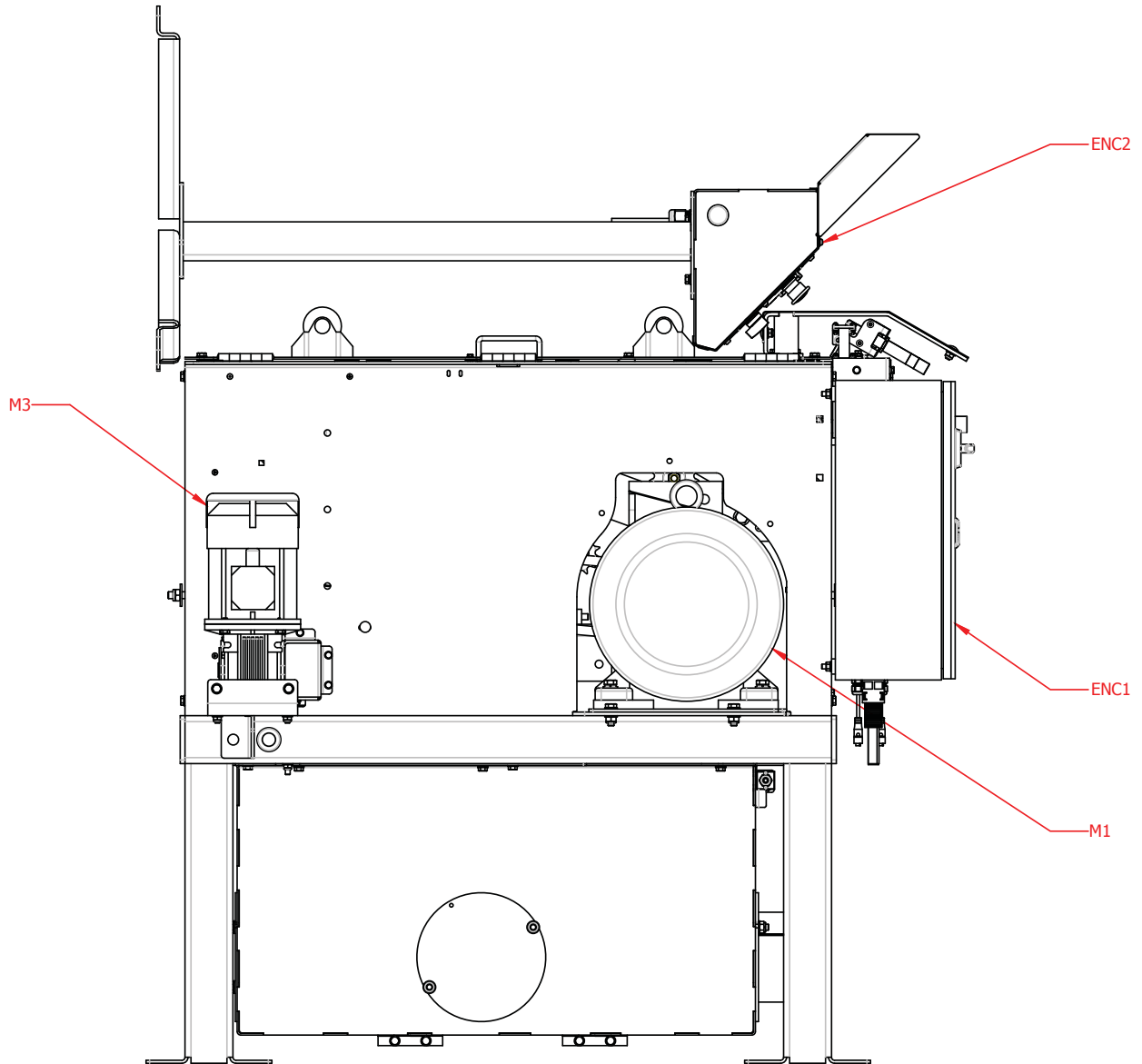

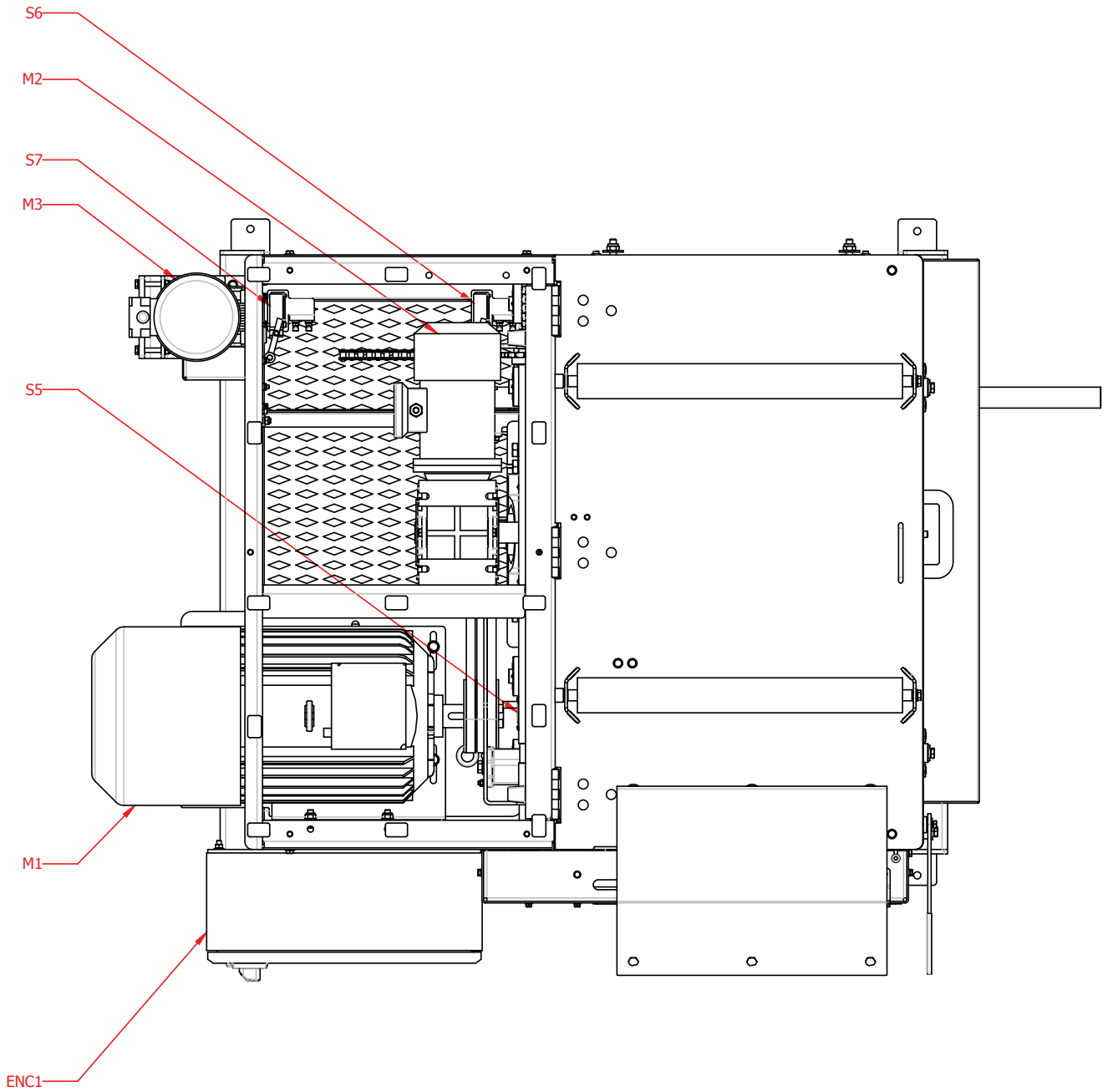

 <b>Wood-Mizer®</b>	
Project Description: EG300EC25U	
Revision: B4.00	Pg Desc: Machine Layout Left
Mounting Location: +Docs	Type: Panel layout
Prev. pg: F5	Page: F6
Next pg: F7	Total Pgs: 27



		<b>Wood-Mizer®</b>	
Project Description: EG300EC25U			
Revision:	B4.00	Pg Desc: Machine Layout Top	
Mounting Location: +Docs		Type: Panel layout	
Prev. pg:	F6	Page:	F7
Next pg:+Mfg_Docs/GI		Total Pgs: 27	