

## **SECTION 1 ELECTRICAL INFORMATION**

**EG300EC25U (U.S. Only) Prior to Rev. B3.00**

FIG. 1-1 SYMBOL DIAGRAM (EG300EC25U PAGE 1 OF 5)

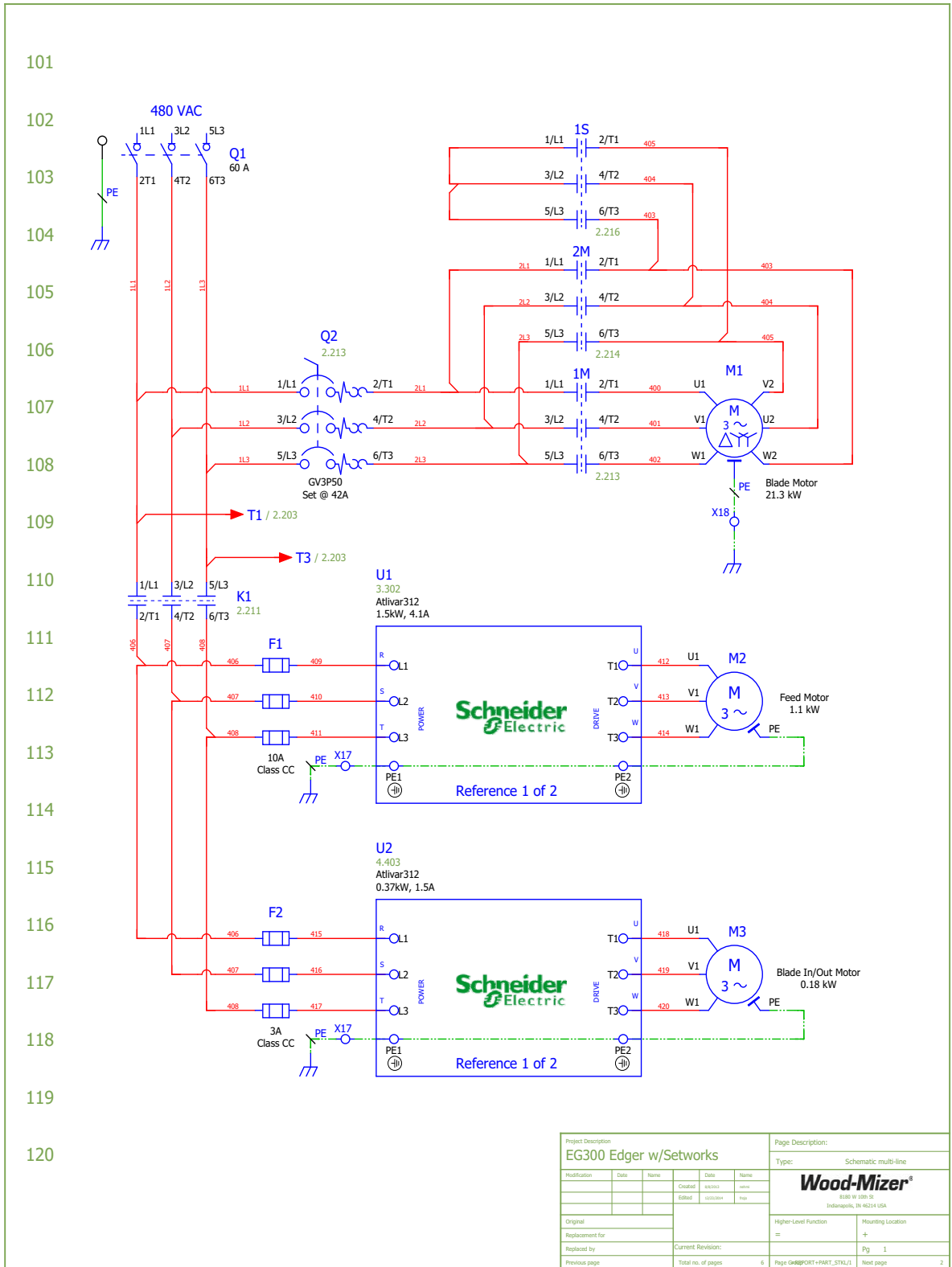

Project Description				Page Description:			
EG300 Edger w/Setworks				Type: Schematic multi-line			
Modification	Date	Name	Created	Date	Name	Wood-Mizer®	
			Edited			8800 W 10th St Indianapolis, IN 46254 USA	
Original						Higher-Level Function	Mounting Location
Replacement for						=	+
Replaced by			Current Revision:				Pg 1
Previous page			Total no. of pages	6	Page GEBBPORT+PART_STX1.1		Next page 2

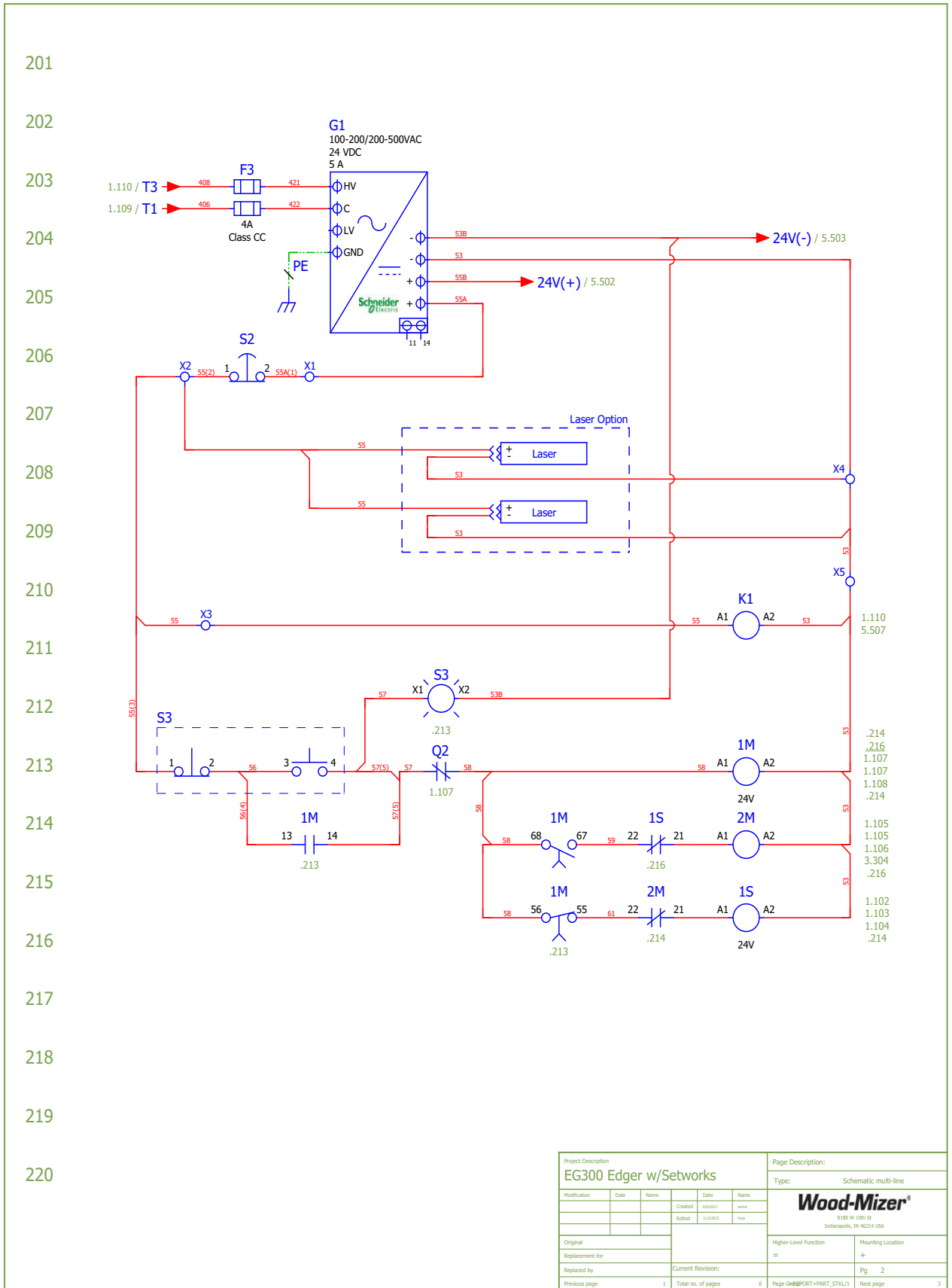

Project Description <b>EG300 Edger w/Setworks</b>						Page Description: Type: Schematic multi-line	
Modification	Date	Name	Created	Date	Name	 B180 W 1075 S Indianapolis, IN 46214 USA	
			Edited				
Original						Higher-Level Function	Mounting Location
Replacement for						=	+
Replaced by			Current Revision:				Pg 2
Previous page	1	Total no. of pages	6	Page	Gr88PORT+PART_STX11	Next page	3

FIG. 1-3 SYMBOL DIAGRAM (EG300EC25U PAGE 3 OF 5)

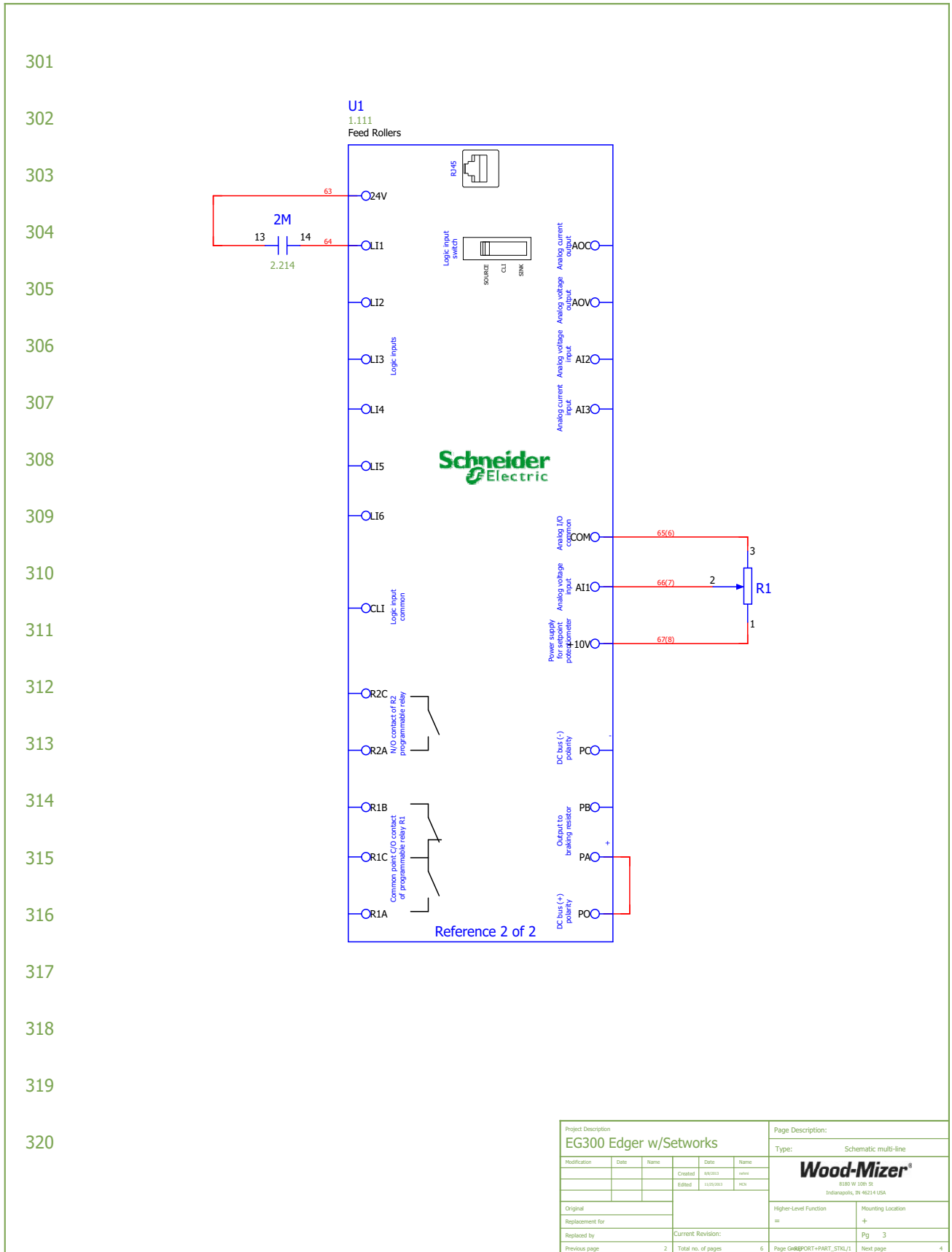

FIG. 1-4 SYMBOL DIAGRAM (EG300EC25U PAGE 4 OF 5)

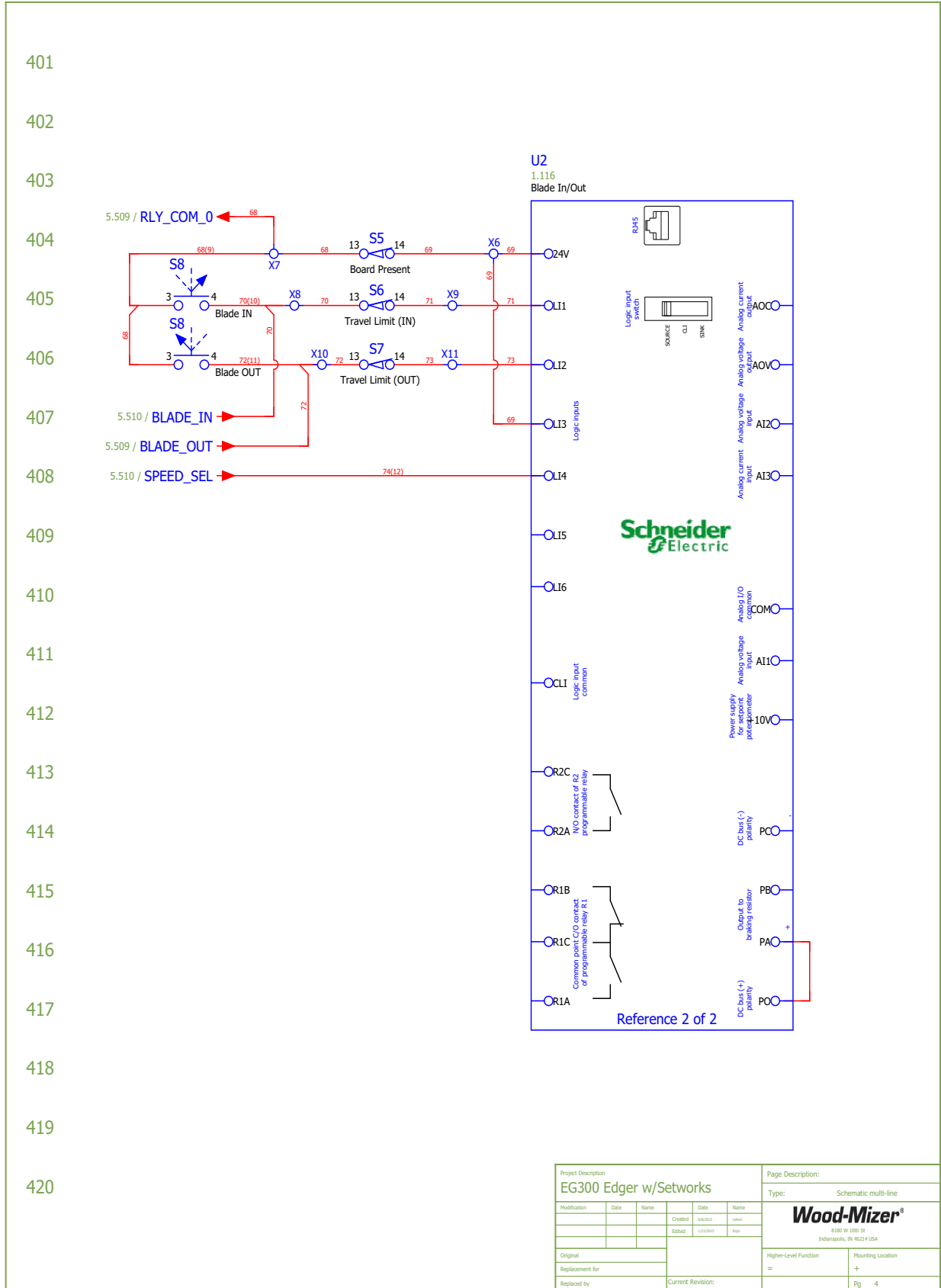
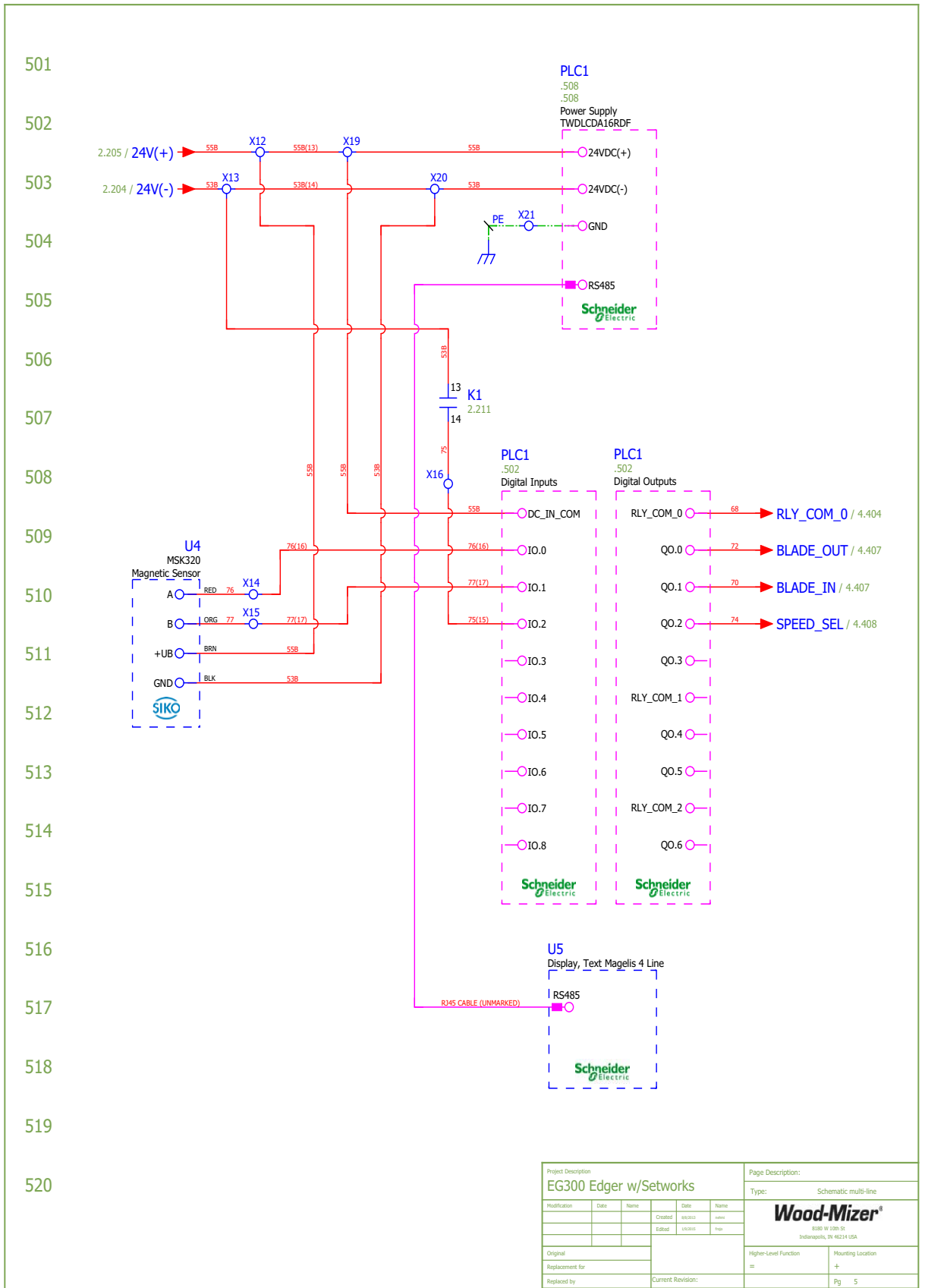

FIG. 1-5 SYMBOL DIAGRAM (EG300EC25U PAGE 5 OF 5)



Project Description <b>EG300 Edger w/Setworks</b>						Page Description: Type: Schematic multi-line	
Modification	Date	Name	Date	Name	Created	Issued	Approved
					Edited	Withdrawn	Yes
Original						Higher-Level Function	
Replacement for						Mounting Location	
Replaced by						Pg 5	
						<b>Wood-Mizer®</b> 6280 W. 13th St. Indianapolis, IN 46214 USA	

**Electrical Component List, , EG300EC25U (U.S. Only)**

Symbol	Manufacturer	Manufacturer Part No.	Wood-Mizer Part No.	Description
1M	SE	LC1D32BD	052465	Contacto TeSys LC1-D - 3P - AC-3 440V 32A
2M	SE	LC1D32BD	052465	Contacto TeSys LC1-D - 3P - AC-3 440V 32A
1S	SE	LC1D32BD	052465	Contacto TeSys LC1-D - 3P - AC-3 440V 32A
F1	WAGO	WAGO-811-431	068067	Fuse Holder, 3P Class CC Wire Clamp
	Littlefuse	CCMR010	051957	Fuse, 10A 600V Class CC Delay
F2	WAGO	WAGO-811-431	068067	Fuse Holder, 3P Class CC Wire Clamp
	Littlefuse	CCMR003	052793	Class CC Fuse 3 A
F3	WAGO	811.421	068066	Class CC Fuse Holder 30 A
	Littlefuse	CCMR004	052713	Class CC Fuse 4 A
G1	SE	ABL8RPS24050	069936	Two-phase power supply
H1	TEL	XB4 BVB3	024970-3	Pilot Light, Complete Assy Green
K1	SE	LC1D18BL	024911	Contacto TeSys LC1-D - 3P - AC-3 440V 18 A
PLC1	Schneider Electric	TWDLCA16DRF	069849	PLC Assy, Twido 16 IO
Q1	ABB	ABB-OT45F3	050881-1	Switch Disconnecto
Q2	Schneider Electric	GV3P50	073503	Motor Starter, GV3P50 37-50A 3P
	SE	GVAM11	---	Auxiliary Contact
R1	Automation Direct	ECX2300-5K	---	Potentiometer, 22mm 5k
S2	Schneider Electric	ZBE1025 068921	068921	Contact Block, 1NC Wire Clamp
	Schneider Electric	ZB5AS54 068940	068940	Pushbutton Head, 22mm E-Stop Twist-Pull
S3	Schneider Electric	ZB5 AW7A3741	068909	Pushbutton, Green Flush/Red Flush Illuminated Double-Headed
	Schneider Electric	ZB5AZ1025	068950	Pushbutton Collar, 1NC ZB5 Wire Clamp
	Schneider Electric	ZBE1015	068920	Contact Block, 1NO Wire Clamp
	Schneider Electric	ZBVB35	068910	Light Module, Green ZB5
S5	Schneider	XCKD2102N12	069772	Limit Switch, Modular Roller
S6	Schneider	XCKD2145M12	---	Limit Switch, Roller Lever
S7	Schneider	XCKD2145M12	---	Limit Switch, Roller Lever
S8	Schneider	ZB5AJ5	---	Selector Switch Head, 3 Pos Spring Return
	Schneider Electric	ZBE10	068920	Contact Block, 1NO Wire Clamp
	Schneider Electric	ZB5AZ1015	068952	Pushbutton Collar, 1NO ZB5 Wire Clamp
TDR1	Schneider Electric	LADS2	069732	Relay, Time Delay Auxillary
U1	Schneider Electric	SQD-ATV312HU15N4	052093-1	Altivar 312 Variable Speed Drive, 2HP
U2	Schneider Electric	SQD-ATV312H037N4	068094	Altivar 312 Variable Speed Drive, 0.5HP
U4	SIKO	---	096014	Sensor Assembly, MSK-320
U5	Schneider Electric	XBTN400	069835	Display, Text Magelis 4 Line 24VDC Green