



Single Blade Edger

Safety, Operation, Maintenance & Parts Manual

SBEG10/EG50G10

rev. A1.01 - A2.02



Safety is our #1 concern! Read and understand all safety information and instructions before operating, setting up or maintaining this machine.

July 2010

Form #1622

Table of Contents

Section-Page

SECTION 1	INTRODUCTION	1-1
1.1	About This Manual.....	1-1
1.2	Getting Service.....	1-2
1.3	Specifications.....	1-4
1.4	Customer and Equipment Identification.....	1-5
SECTION 2	SAFETY	2-1
2.1	Safety Symbols.....	2-1
2.2	Safety Instructions.....	2-2
SECTION 3	SETUP & OPERATION	3-1
3.1	Setup.....	3-1
3.2	Alignment.....	3-5
3.3	Operation.....	3-8
3.4	Transporting The Edger.....	3-10
SECTION 4	MAINTENANCE	4-1
4.1	Drive System.....	4-1
4.2	Feed Table Rollers.....	4-2
4.3	Blade System.....	4-3
SECTION 5	REPLACEMENT PARTS	5-1
5.1	Edger.....	5-1
5.2	Frame Assembly.....	5-2
5.3	Frame Assembly.....	5-4
5.4	Guide Fence Assembly.....	5-6
5.5	Rear Leg Assembly.....	5-8
5.6	Blade Assembly.....	5-9
5.7	Blade Cover Assembly.....	5-11
5.8	Engine Assembly.....	5-12
5.9	Engine Assembly.....	5-14
	INDEX	I

SECTION 1 INTRODUCTION

1.1 About This Manual

This manual is to replace or to be used with all previous information received on the Wood-Mizer® * Single Blade Edger. All future mailings will be an addition to or a revision of individual sections of this manual as we obtain new information.

The information and instructions given in this manual do not amend or extend the limited warranties for the equipment given at the time of purchase.

Important components of the edger are identified below.

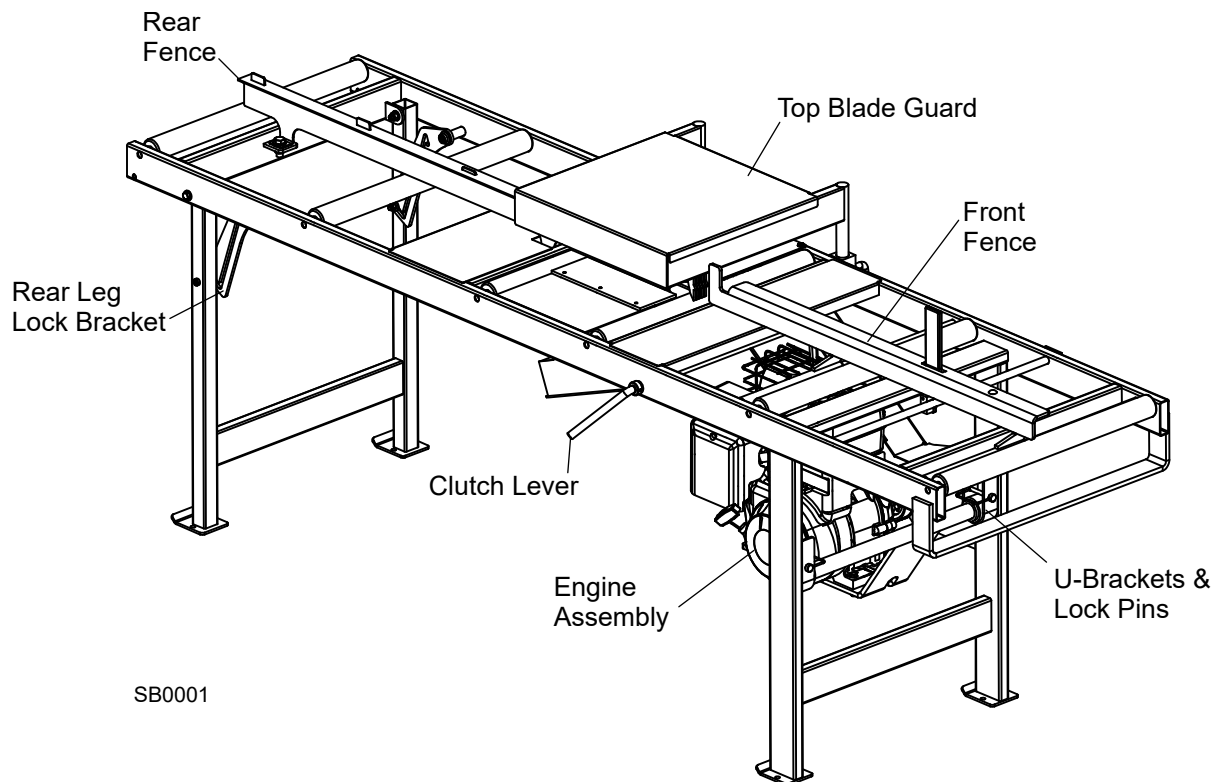

*Wood-Mizer® is a registered trademark of Wood-Mizer Products, Inc.

1.2 Getting Service

Wood-Mizer is committed to providing you with the latest technology, best quality and strongest customer service available on the market today. We continually evaluate our customers' needs to ensure we're meeting current wood-processing demands. Your comments and suggestions are welcome.

General Contact Information

Toll free phone numbers are listed below for the *continental* U.S. and Canada. See the next page for contact information for specific Wood-Mizer locations.

	United States	Canada
Sales	1-800-553-0182	1-877-866-0667
Service	1-800-525-8100	1-877-866-0667
Website	www.woodmizer.com	www.woodmizer.ca
E-mail	woodmizer@woodmizer.com	oninfo@woodmizer.com

Office Hours: All times are Eastern Standard Time.

Monday - Friday	Saturday (Indianapolis Office Only)	Sunday
8 a.m. to 5 p.m.	8 a.m. to 12 p.m.	Closed

Please have your vehicle identification number and your customer number ready when you call.

Wood-Mizer will accept these methods of payment:

- Visa, Mastercard, or Discover
- COD
- Prepayment
- Net 15 (with approved credit)

Be aware that shipping and handling charges may apply. Handling charges are based on size and quantity of order. In most cases, items will ship on the day they are ordered. Second Day and Next Day shipping are available at additional cost.

If your sawmill was purchased outside the United States or Canada, contact the distributor for service.

Wood-Mizer Locations

USA World Headquarters

Serving North & South America, Oceania, East Asia

Wood-Mizer LLC
8180 West 10th Street
Indianapolis, IN 46214

Phone: 317.271.1542 or 800.553.0182
Customer Service: 800.525.8100
Fax: 317.273.1011
Email: infocenter@woodmizer.com

Canadian Headquarters

Serving Canada

Wood-Mizer Canada
396 County Road 36, Unit B
Lindsay, ON K9V 4R3

Phone: 705.878.5255 or 877.357.3373
Fax: 705.878.5355
Email: ContactCanada@woodmizer.com

Brazil Headquarters

Serving Brazil

Wood-Mizer do Brasil
Rua Dom Pedro 1, No: 205 Bairro: Sao Jose
Ivoti/RS CEP:93.900-000

Tel: +55 51 9894-6461/ +55 21 8030-3338/ +55 51
3563-4784
Email: info@woodmizer.com.br

Europe Headquarters

Serving Europe, Africa, West Asia

Wood-Mizer Industries Sp z o.o.
Nagorna 114
62-600 Kolo, Poland

Phone: +48.63.26.26.000
Fax: +48.63.27.22.327

Branches & Authorized Sales Centers

For a complete list of dealers, visit www.woodmizer.com

1.3 Specifications

Model: SBEG10/EG50G10 Rev. A1.01+

Dimensions

Length: 96"
Width: 35 3/4"
Height: 40"
Table Height: 32 5/8"
Weight: 373 lbs (480 lbs w/shipping crate)

Capacity:

Min. Output Width (Fence to Blade): 2"
Max. Output Width (Fence to Blade): 12"
Min. Material Thickness: 1/4"
Max. Material Thickness: 2 1/4"

Misc Specifications

Blade Diameter: 10"
Blade Bore: 5/8"
Blade Kerf (24 Tooth): .125"

Engine/Motor:

Fuel/Energy: Gas
Make: Briggs
HP Rating: 10.4
Weight: 52.8 lbs
RPM-Idle: 1750 RPM
RPM-High (No load): 3750 RPM
Noise Level (Operator; not cutting/cutting; dBA):
Noise Level (Puller; not cutting/cutting; dBA):
Blade Speed (No load) RPM: 3750
Fuel Consumption (Gallon/Clock Hr.):
Cooling: Air
Engine Drive Shaft O.D. (inches): 1"
Engine Drive Pulley: 3.65"
Main Driven Pulley: 3.65"
Drive Belt: 2/3VX600
Oil Capacity w/Filter (qts.): .875 qts. (.8 liters)

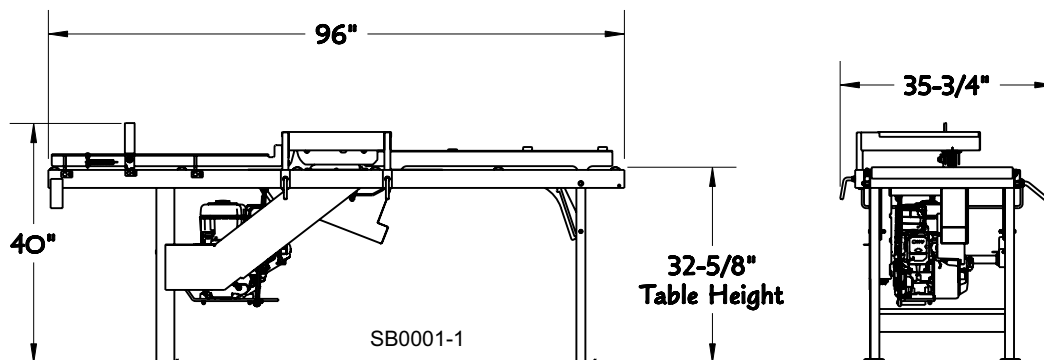

1.4 Customer and Equipment Identification

An identification plate is located on unit. The plate contains the model and revision information for your unit. You will also receive a customer number when you purchase your unit.

These numbers will help expedite our service to you. Please locate them now and write them below so you have quick, easy access to them.

Identification Information (To be filled in by purchaser)

Model No. _____

Revision No. _____

Customer No. _____

MFG BY/ FABRIQUÉ PAR: WOOD-MIZER PRODUCTS, INC. 8180 W. 10th St. Indianapolis, IN 46214-2400 U.S.A. 317/ 271-1542 Or 800/ 553-0182	
Model No.:	SBEG10
Serial No.:	08090001
Rev.:	A1.00
SB0002	

IDENTIFICATION PLATE

SECTION 2 SAFETY

2.1 Safety Symbols

The following symbols and signal words call your attention to instructions concerning your personal safety. Be sure to observe and follow these instructions.



DANGER! indicates an imminently hazardous situation which, if not avoided, will result in death or serious injury.



WARNING! suggests a potentially hazardous situation which, if not avoided, could result in death or serious injury.



CAUTION! refers to potentially hazardous situations which, if not avoided, may result in minor or moderate injury or damage to equipment.



IMPORTANT! indicates vital information.

NOTE: gives helpful information.



Warning stripes are placed on areas where a single decal would be insufficient. To avoid serious injury, keep out of the path of any equipment marked with warning stripes.

2.2 Safety Instructions

Read and observe all safety instructions before operating this equipment! Also read any additional manufacturer's manuals and observe any applicable safety instructions including dangers, warnings, and cautions.

Always be sure that all safety decals are clean and readable. Replace all damaged safety decals to prevent personal injury or damage to the equipment. Contact your local distributor, or call your Customer Service Representative to order more decals.



IMPORTANT! It is always the owner's responsibility to comply with all applicable federal, state and local laws, rules and regulations regarding the ownership and operation of your Wood-Mizer Edger. All Wood-Mizer Edger owners are encouraged to become thoroughly familiar with these applicable laws and comply with them fully while using the equipment.

Always properly dispose of all sawing by-products, including sawdust and other debris, coolant, oil, fuel, oil filters and fuel filters.

DISPOSE OF SAWING BY-PRODUCTS PROPERLY



WARNING! Clean sawdust from all guards, vents, control boxes, or any area where sawdust may gather after every shift. Failure to do so may result in fire, causing death or serious injury.



IMPORTANT! Always properly dispose of all sawing by-products, including sawdust and other debris, coolant, oil, fuel, oil filters and fuel filters.

Edger Setup and Transportation Safety



WARNING! When setting up or transporting the Edger, avoid areas marked as pinch points. These are located near the rear folding leg and the engine pulley. Keep your hands away from these areas to prevent injury.



WARNING! Always wear gloves and eye protection when handling blades. Failure to do so may result in serious injury.



CAUTION! Before operating the Edger, be sure to remove

2 **Safety** *Safety Instructions*

the shipping block from under the blade cover. Failure to do so will cause damage to the machine.

Edger Operation Safety



DANGER! Make sure all guards and covers are in place and secured before operating or transporting the Edger. Failure to do so may result in serious injury.

DANGER! Always keep hands away from moving blade. Blade may still be moving even when the clutch lever is disengaged. Failure to do so will result in serious injury.

DANGER! Keep all persons out of the path of moving equipment and boards when operating the Edger or loading boards. Failure to do so will result in serious injury.

DANGER! Maintain a clean and clear path for all necessary movement around the Edger and lumber stacking areas. Failure to do so will result in serious injury.

DANGER! Always be sure the blade is disengaged and all persons are out of the path of the blade before starting the engine or motor. Failure to do so will result in serious injury.

DANGER! Always shut off the engine and allow all moving parts to come to a complete stop before removing any guards or covers. Failure to do so will result in serious injury.



WARNING! Always shut off the engine to stop the blade whenever the Edger is not in use. Failure to do so may result in serious injury.

WARNING! Always wear eye, ear, respiration, and foot protection when operating the Edger. Failure to do so may result in serious injury.

WARNING! Secure all loose clothing and jewelry before operating the Edger. Failure to do so may result in serious injury or death.

WARNING! Kickback Hazard. Stay clear of area during operation. Follow all anti-kickback service and safety rules. Failure to do so may result in serious injury.



CAUTION! Avoid resting boards or other objects on the blade guard. Damage to the guard may result.

Refueling and Engine Operation Safety



DANGER! Always be sure the blade is disengaged and all persons are out of the path of the blade before starting the engine or motor. Failure to do so will result in serious injury.



WARNING! Store gasoline away from sawdust and other flammable materials. Also remove sawdust from above the engine tank before refueling. Failure to do so may result in serious injury.

WARNING! Use an appropriate funnel to refuel tank. Remove any spilled fuel from area before starting engine. Failure to do so may result in serious injury.

WARNING! Do not for any reason adjust the engine drive belts or belt support bracket with the engine running. Doing so may result in serious injury.

WARNING! Always wear proper and necessary safety equipment when performing service functions. Proper safety equipment includes eye protection, breathing protection, hand protection and foot protection.

WARNING! The engine exhaust from this product contains chemicals known to the State of California to cause cancer, birth defects or other reproductive harm.



CAUTION! Do not lift the engine by the carburetor when replacing the drive belt. Damage to the engine may result.

SECTION 3 SETUP & OPERATION

3.1 Setup



CAUTION! Before operating the Edger, be sure to remove the shipping block from under the blade cover. Failure to do so will cause damage to the machine.

1. A shipping block supports the blade guard during factory shipment. Remove this block before operating the Edger. To remove:
 - Loosen the two mount knobs on the right side of the blade guard. Lift the guard from the machine and remove the shipping block.
 - Replace the blade guard. Retighten the mount knobs.
2. Unfold the rear leg. Swing the leg all the way down until they lock in position. Be sure the pivot bolts seat in the brace notches.



WARNING! When setting up or transporting the Edger, avoid areas marked as pinch points. These are located near the rear folding leg and the engine pulley. Keep your hands away from these areas to prevent injury.

See Figure 3-1.

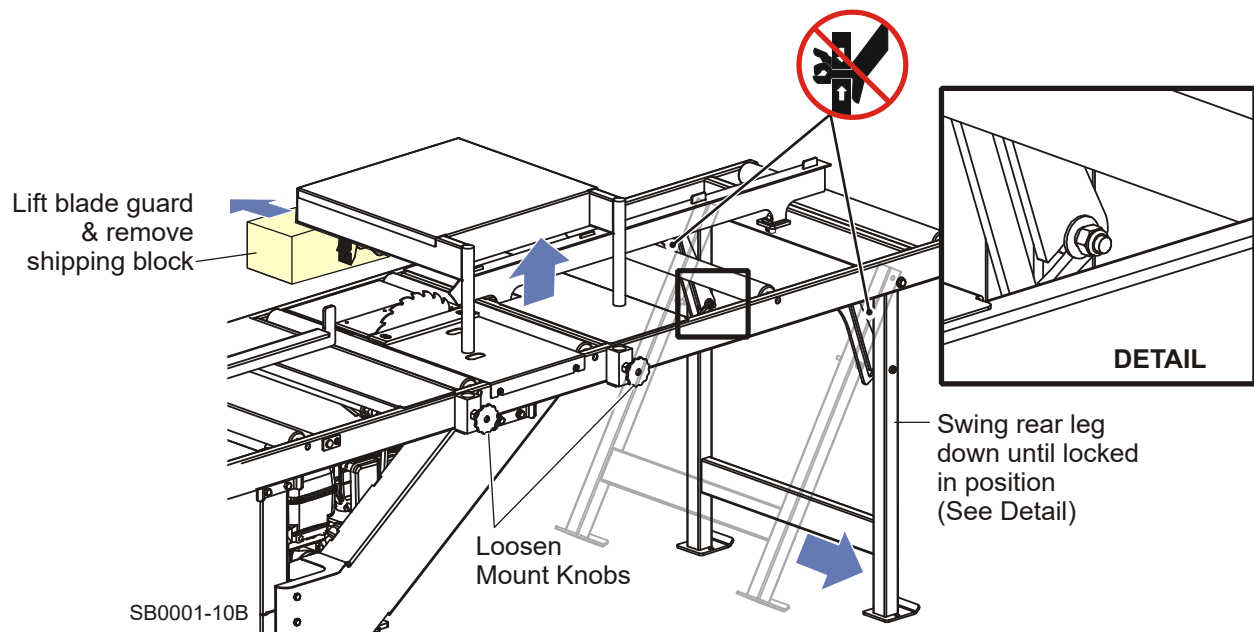

FIG. 3-1

3 Setup & Operation

Setup

3. Install the engine. To install:

See Figure 3-2.

- Position the engine beneath the Edger.
- Remove the U-bracket lock pins and clutch retaining pin. Raise the clutch handle.

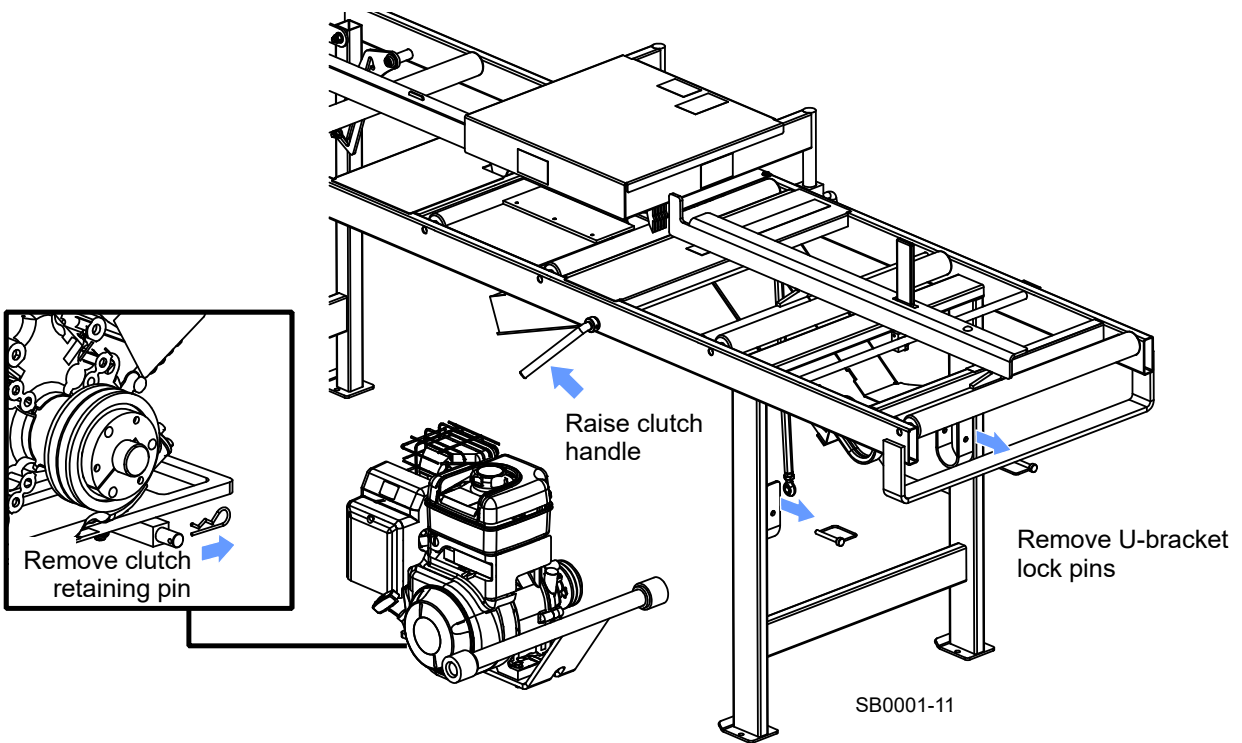

FIG. 3-2

See Figure 3-3.

- Place the ends of the engine mounting bar in the U-brackets and reinstall the U-bracket lock pins.
- Position the drive belt around the engine pulley.



WARNING! When setting up or transporting the Edger, avoid areas marked as pinch points. These are located near the rear folding leg and the engine pulley. Keep your hands away from these areas to prevent injury.

- Connect the clutch linkage to the motor mount plate pin and replace the retaining pin.

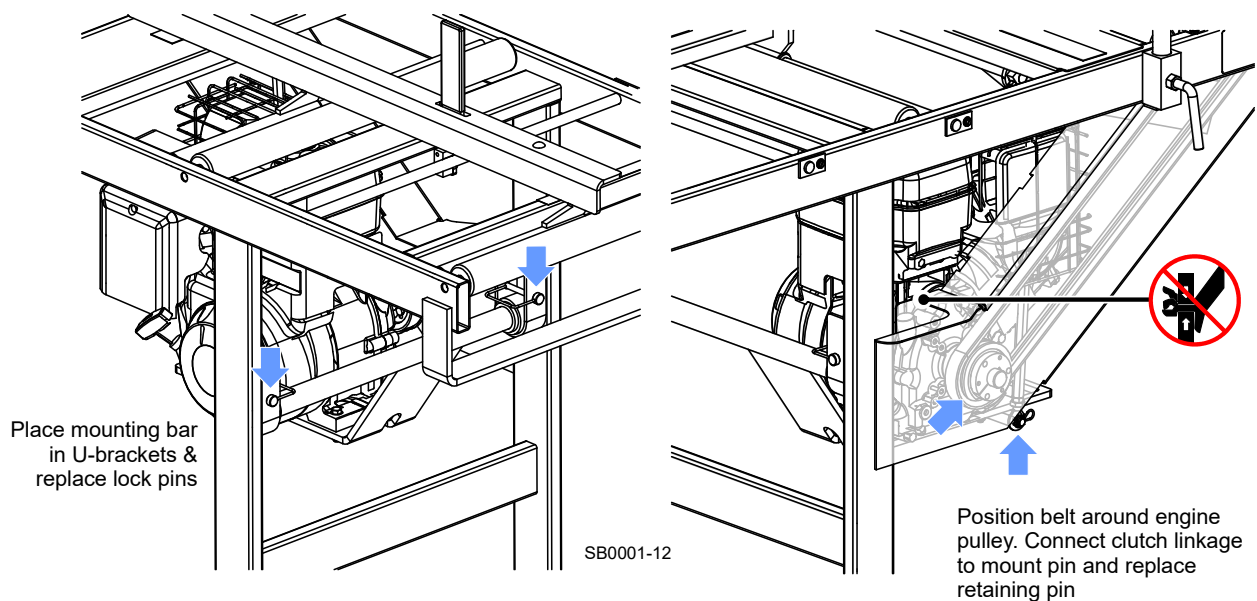

FIG. 3-3

4. If necessary, level the Edger by shimming under the leg foot pads. **NOTE:** Adjust the rear of the edger slightly lower than the front to allow gravity to assist in feeding boards.

3 Setup & Operation

Setup

5. Adjust the front guide fence:

See Figure 3-4.

- The guide scale shows how many inches the front fence is from the blade. This helps you to determine the width of lumber you will be sawing.
- For example, if you wish to cut 2" lumber, you will need to adjust the front fence 2" from the blade, or to the 2" mark on the guide scale. The front fence can be adjusted as often as necessary.
- The front fence can be adjusted from 0 to 12". To adjust the front fence, pull the fence lock handle and slide the fence to the desired position. Release the fence lock handle to lock the fence into place.

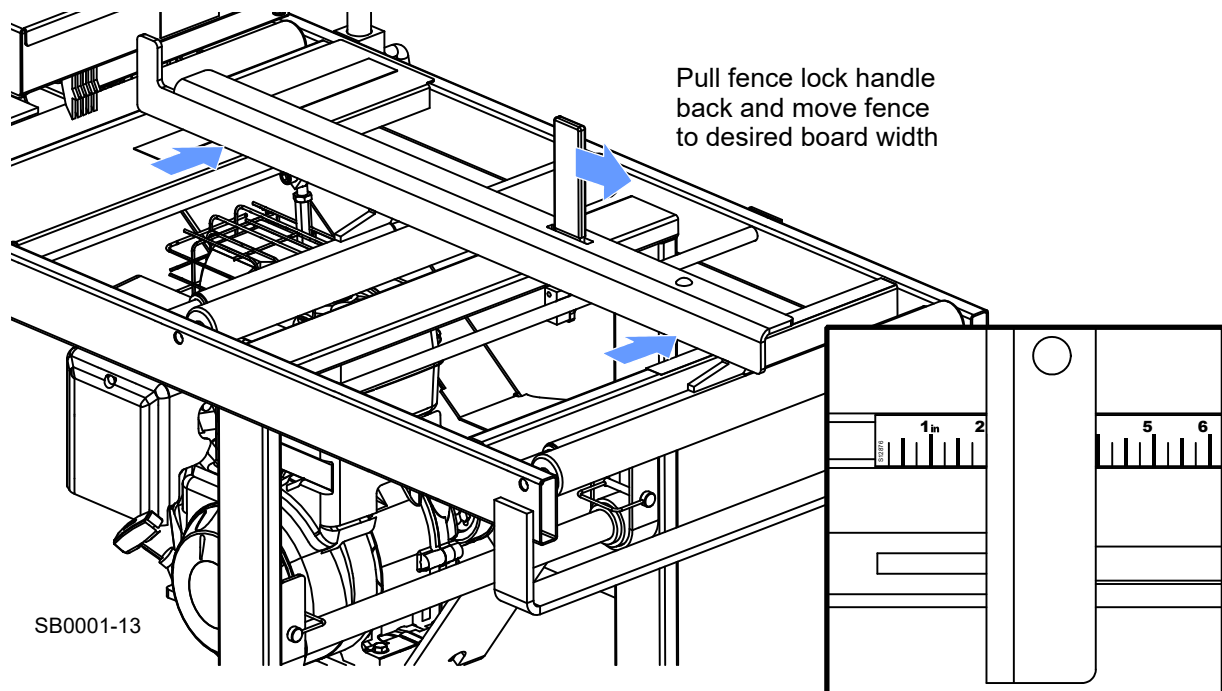

FIG. 3-4

3.2 Alignment

Proper machine alignment is important for optimum cutting performance. Check machine alignment often and adjust as necessary. To check:

1. Adjust the front fence to the 5" position. Be sure the blade clutch handle is disengaged.
2. Loosen the mount knobs and remove the blade guard. Unscrew and remove the blade bearing cover plate.

See Figure 3-5.

3. Tie one end of a string (string must be approximately 11' or longer in length) to the front fence tab. Route the string around the front end of the fence. Pulling the string tight, align it with the face of the front fence along the entire length of fence.

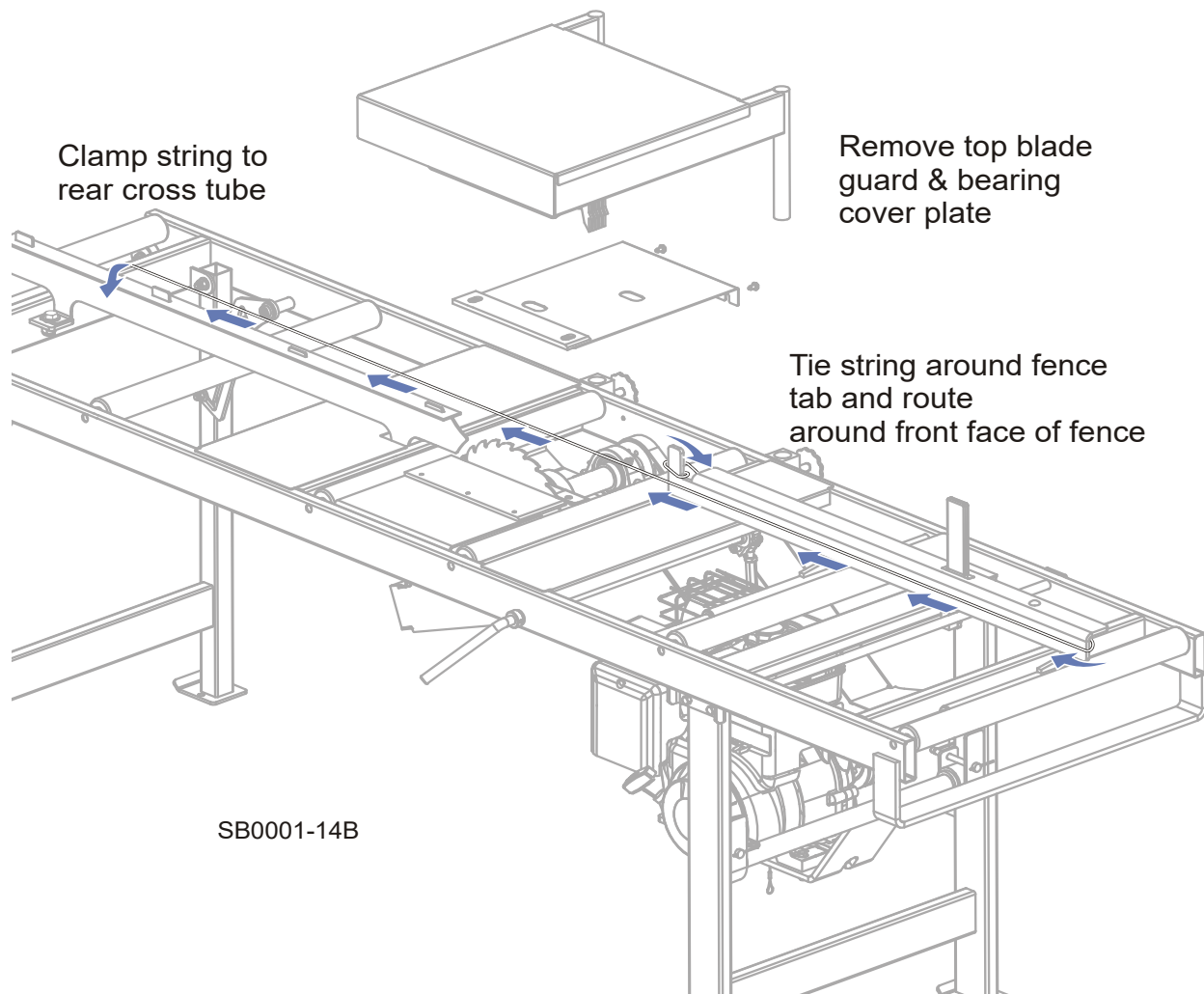

FIG. 3-5

3

Setup & Operation

Alignment

4. Use a C-clamp to secure the string to the rear frame cross tube, maintaining the string alignment to the front fence.
5. Measure the distance between the face of the blade and the string at each end of the blade. The measurements should be the same as the front fence setting (5 inches) at both ends.

See Figure 3-6.

6. If necessary, loosen the blade shaft bearing mount bolts and adjust the position of the blade. Retighten the bearing mount bolts. After adjusting the blade, loosen the blade filler plate thumb screws and adjust the plate close to, but not touching the blade. Retighten the thumb screws.

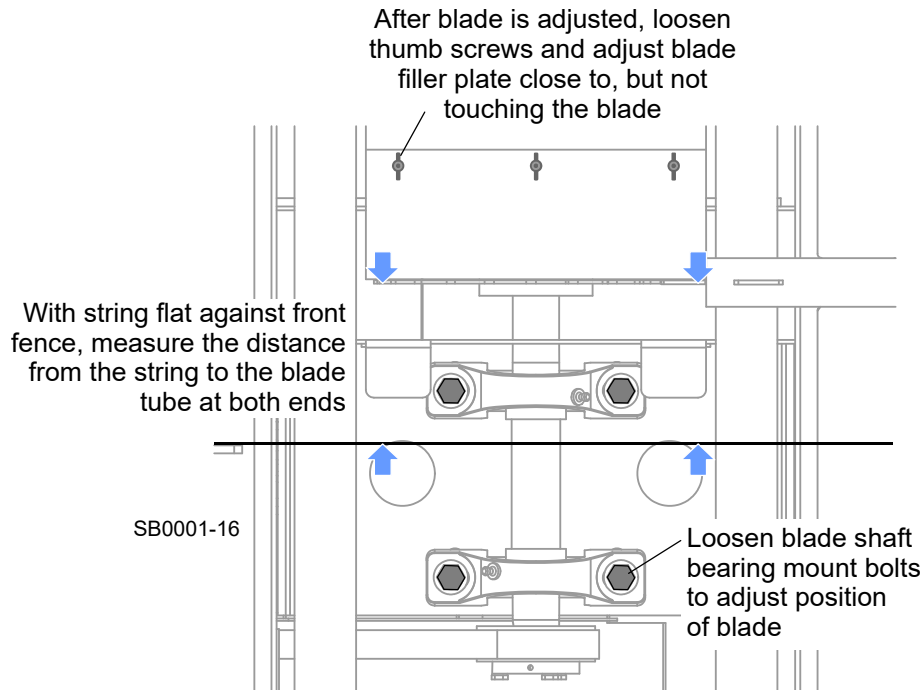

FIG. 3-6

7. Measure the distance between the face of the rear fence and the string at each end of the rear fence. The measurements should be the same as the front fence setting (5 inches).

See Figure 3-7. If necessary, loosen the locking nuts and move the rear fence rail as necessary. Retighten the nuts.

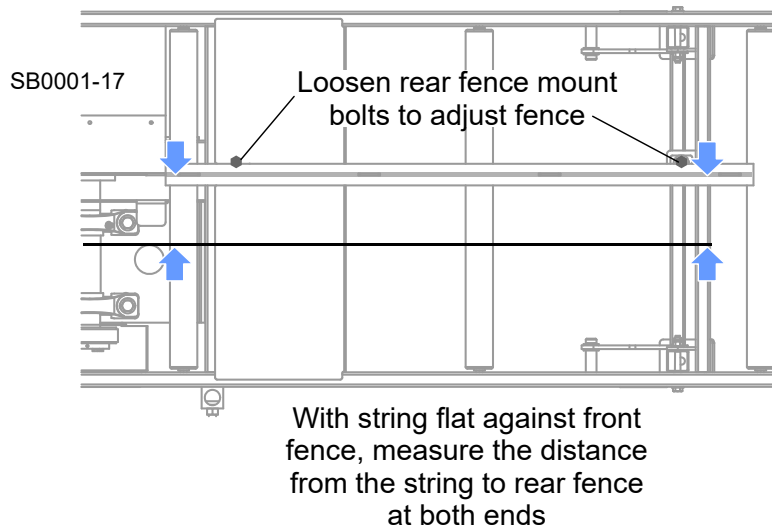

FIG. 3-7

3.3 Operation

1. Make sure the Edger has been properly set up and the blade guard and fences have been properly adjusted to cut your size boards. [See Section 3.1.](#)
2. Check the alignment. [See Section 3.2.](#)
3. Start the engine:



DANGER! Always be sure the blade is disengaged and all persons are out of the path of the blade before starting the engine or motor. Failure to do so will result in serious injury.



DANGER! Make sure all guards and covers are in place and secured before operating or transporting the Edger. Failure to do so may result in serious injury.



WARNING! Always wear eye, ear, respiration, and foot protection when operating the Edger. Failure to do so may result in serious injury.

WARNING! Secure all loose clothing and jewelry before operating the Edger. Failure to do so may result in serious injury or death.

- Making sure the clutch lever is disengaged (in the raised position), turn the engine switch located on top of the engine to the ON position.
 - Move the choke to the START position.
 - Pull the engine cord slowly until you feel resistance, then pull the cord quickly to start the engine. Repeat with the choke opened slightly if necessary.
 - When the engine starts, slowly open the choke all the way by moving the choke lever to the OFF position.
4. Begin edging:
 - Lower the clutch lever to engage the blade. Push the lever down until the clutch linkage locks into the engaged position.



DANGER! Always keep hands away from moving blade. Blade may still be moving even when the clutch lever is disengaged. Failure to do so will result in serious injury.

DANGER! Keep all persons out of the path of moving equipment and boards when operating the Edger or loading boards. Failure to do so will result in serious injury.

DANGER! Maintain a clean and clear path for all necessary movement around the Edger and lumber stacking areas. Failure to do so will result in serious injury.



CAUTION! Avoid resting boards or other objects on the blade guard. Damage to the guard may result.

- Position a board against the front fence. Push the board into the blade until the board begins to feed itself.
- Measure the edged board to make sure the front fence is adjusted properly. If the measurements are not correct, readjust the front fence and repeat step 4.

5. TO SHUT OFF THE ENGINE, turn the engine switch to the OFF position.



WARNING! Always shut off the engine to stop the blade whenever the Edger is not in use. Failure to do so may result in serious injury.

3.4 Transporting The Edger

Follow these steps to transport the Edger in a pickup truck (minimum 8' bed required):



WARNING! When setting up or transporting the Edger, avoid areas marked as pinch points. These are located near the rear folding legs and the engine pulley. Keep your hands away from these areas to prevent injury.

1. Make the Edger lighter and more portable by removing the engine. To remove, disconnect the clutch linkage from the motor mount pin and remove the lock pins from the Edger U-brackets. Lift the engine up and remove it from the Edger. Reinstall the lock pins into the U-brackets.
2. Back the truck to the rear of the edger until the truck bed is positioned under the rear of the Edger frame. Lift the weight from the rear Edger leg and fold the leg up to the Edger frame, allowing rollers at the rear of the Edger to rest on the bed of the truck.
3. Slide the Edger into the truck. Secure as necessary for transport.

SECTION 4 MAINTENANCE



DANGER! Always shut off the engine and allow all moving parts to come to a complete stop before removing any guards or covers. Failure to do so will result in serious injury.

4.1 Drive System

1. Refer to the engine manufacturer's owner's manual for engine maintenance recommendations and instructions.
2. Check the drive belt for wear every 8 hours of operation. Replace as necessary.



CAUTION! Do not lift the engine by the carburetor when replacing the drive belt. Damage to the engine may result.

3. Over time, the drive belt will stretch. To tighten the belt, adjust the clutch turnbuckle. If no more adjustment is available, replace the belt.

See Figure 4-1. Loosen the jam nuts at the upper and lower rod ends (note the lower jam nut has left-hand threads). Turn the clutch turnbuckle to the left as viewed to lengthen.

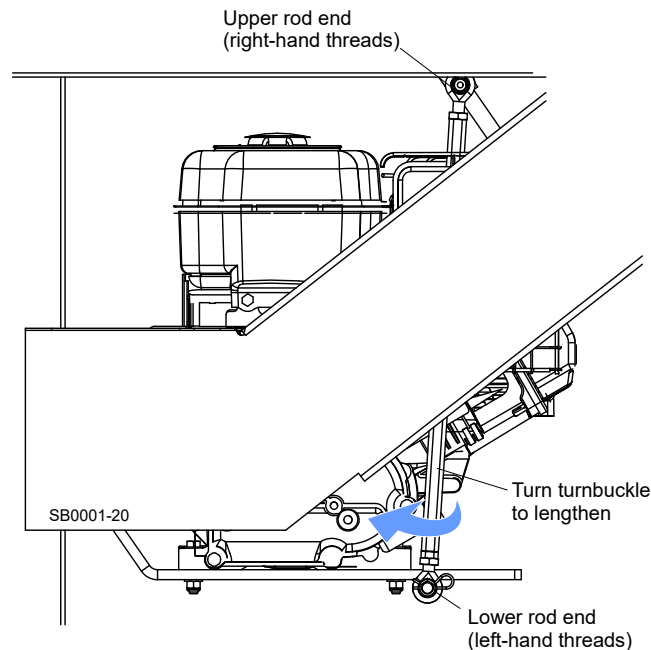

FIG. 4-1

4.2 Feed Table Rollers

25

Check the feed table rollers for wear every 25 hours of operation. Rollers should spin freely, without too much play. To replace, cut the old roller in half and remove it from the edger. Install the new spring-loaded roller.

4.3 Blade System

1. Check the blade every 8 hours of operation. Resharpener or replace as needed.

See Figure 4-2. To replace, loosen the two mount knobs and remove the top blade guard. Unscrew and remove the blade filler plate. Raise the lock bracket to lock the blade shaft in place. Through the access hole in the blade guard, remove the blade retainer bolt (left-hand threads, turn clockwise) and washer. Remove the retainer plate and blade. Install the new blade. Reinstall the washer and the nut. Replace the blade filler plate and the top blade guard. Lower the lock bracket to release the blade shaft.



WARNING! Always wear gloves and eye protection when handling bandsaw blades. Changing blades is safest when done by one person! Keep all other persons away from area when coiling, carrying or changing a blade. Failure to do so may result in serious injury.

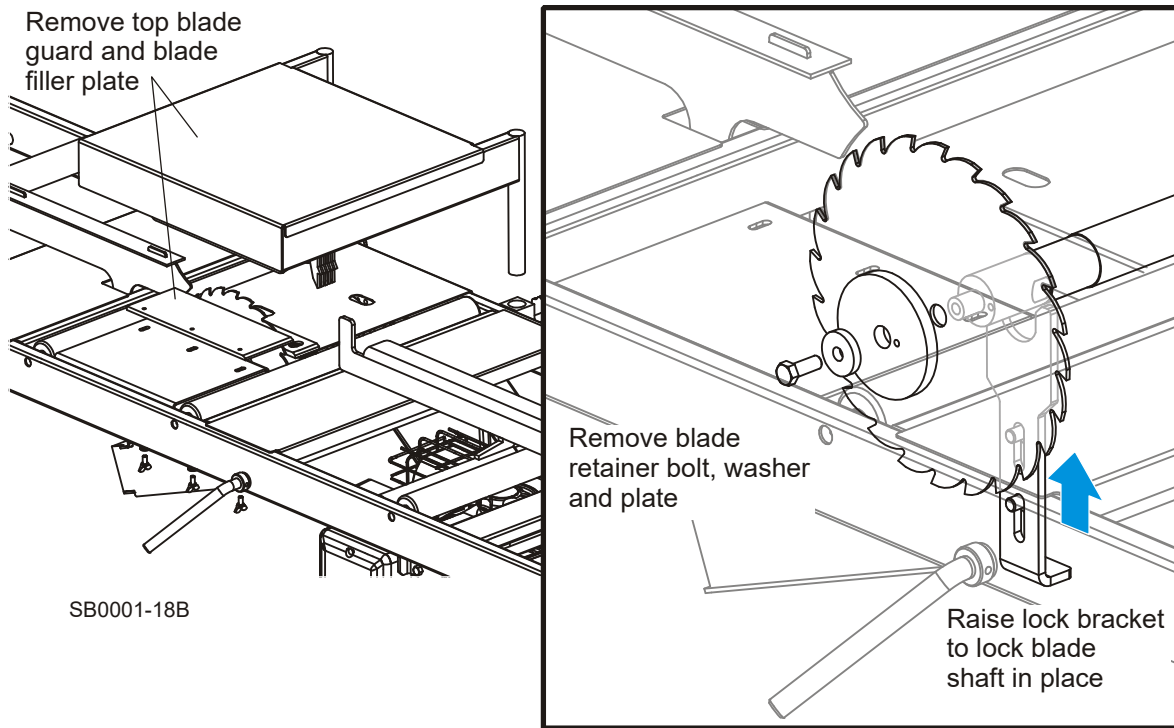

FIG. 4-2

2. Check blade bearing performance every 50 hours of operation. Replace as necessary.

4

Maintenance

Blade System

3. Lubricate the blade bearings every 400 hours of operation. Use a high-quality synthetic grease such as Amoco Rycon #2 or Chevron SRI #2.

400

See **Figure 4-3**. Access the bearing grease fittings through the holes in the blade bearing cover plate.

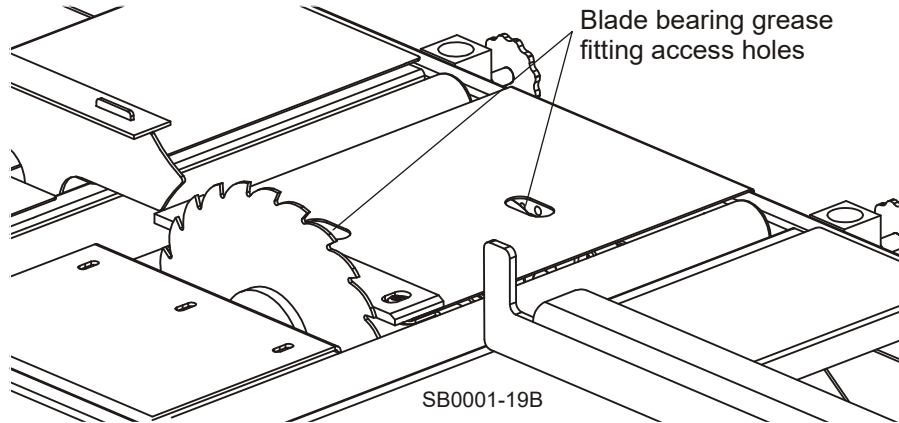
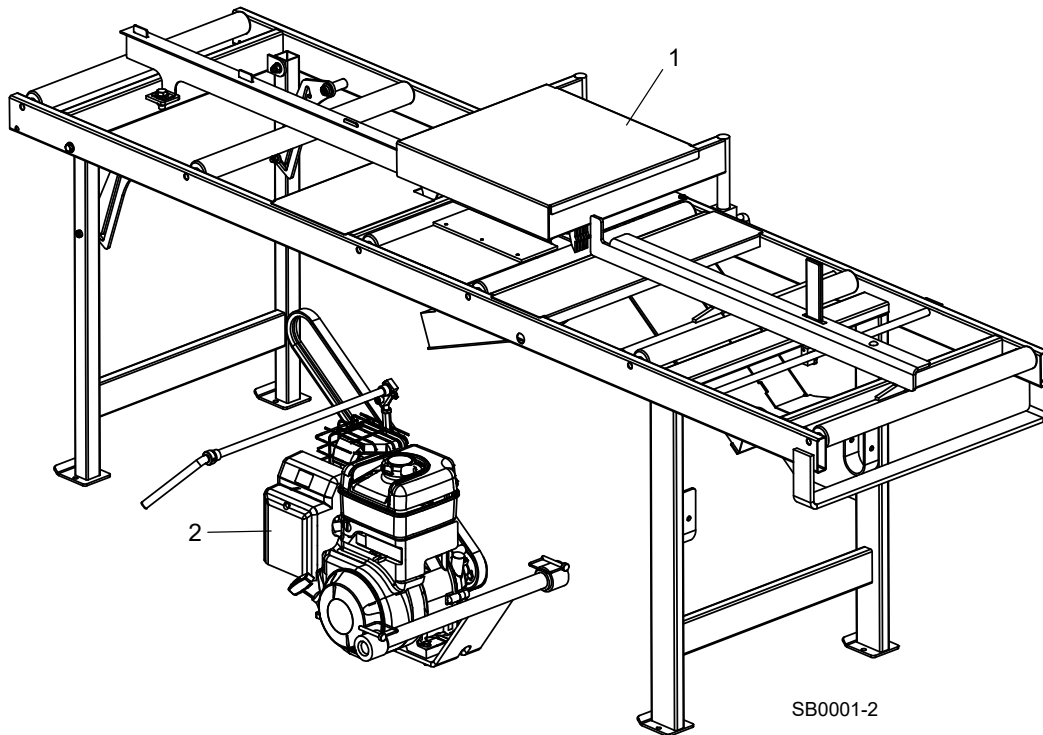

FIG. 4-3

SECTION 5 REPLACEMENT PARTS

5.1 Edger



REF	DESCRIPTION (◆ Indicates Parts Available In Assemblies Only)	PART NUMBER	QTY.
	EDGER, EG50 SINGLE BLADE 10HP GAS	EG50G10 ¹	1
	EDGER, SINGLE BLADE 10HP GAS	SBEG10 ¹	1
1	Edger Parts (See Section 5.2)		
2	Engine Parts (See Section 5.8)		

¹ Model number changed 7/10.

5 Replacement Parts

Frame Assembly

5.2 Frame Assembly

EG50G10

Rev. A1.03+

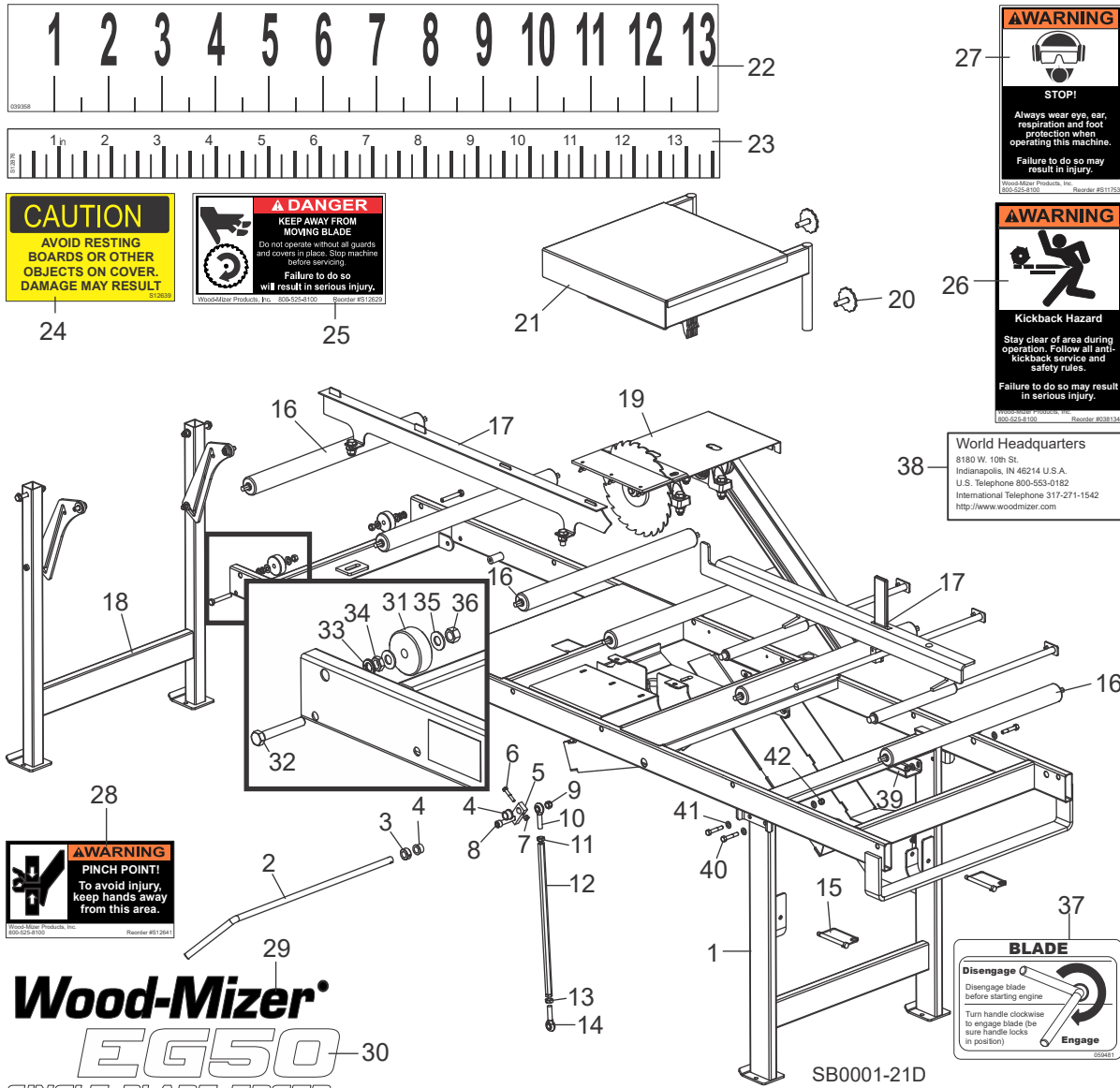

Wood-Mizer
EG50 30
 SINGLE BLADE EDGER

REF	DESCRIPTION (◆ Indicates Parts Available In Assemblies Only)	PART NUMBER	QTY.	
	EDGER, SINGLE BLADE BASE	007180	1	
	Frame Assembly, Single Blade Edger	007176	1	◆
1	Frame Weldment, Single Blade Edger	007154	1	◆
2	Handle, Edger Clutch	007179	1	
3	Collar, 5/8" ID Lock	P05035	1	
4	Bushing, 5/8" ID x 7/8" OD x 1/2" Bronze	P05135	2	
5	Block, Edger Clutch	007178	1	
6	Bolt, 1/4-20 x 1 1/2" Hex Head Grade 5	F05005-124	1	

7	Nut, 1/4-20 Hex Nylon Lock	F05010-69	1	
8	Screw, 7/16-20 x 1 1/2" Socket Head	F05007-120	1	
9	Nut, 7/16-20 Hex Nylon Lock	F05010-83	1	
	Turnbuckle Assembly, Edger Clutch	007197	1	
10	Rod End, 7/16-20 Right Hand Male	P11579	1	
11	Nut, 7/16-20 Hex Jam	F05010-38	1	
12	Turnbuckle, Edger Clutch	007196	1	
13	Nut, 7/16-20 Left Hand Hex Jam	F05010-87	1	
14	Rod End, 7/16-20 Left Hand Male	P11578	1	
15	Pin, 3/8" x 3 1/2" Retaining	046411	2	
16	Roller, 24" Conveyor	007177	6	
17	Fence Parts (See Section 5.4)			
18	Rear Leg Parts (See Section 5.5)			
19	Blade System Parts (See Section 5.6)			
20	Knob Weldment, Control Box Mount	034658	2	
21	Top Blade Guard Parts (See Section 5.7)			
22	Decal, Edger Cover Inch Scale	039358	1	
	Decal, Edger Cover Metric Scale	S12662	1	
23	Decal, Fence Inch Scale	S12876	1	
	Decal, Fence Metric Scale	S12877	1	
24	Decal, Edger Cover Caution	S12639	1	
25	Decal, Moving Blade Danger	S12629	4	
26	Decal, Kickback Hazard Warning	038134	1	
27	Decal, Eye/Ear Warning	S11753	1	
28	Decal, Hand Pinch Warning	S12641	3	
29	Decal, 2 1/2" Wood-Mizer Logo	049401	2	
30	Decal, EG50 Euro Logo White	062724 ¹	2	
31	Roller, 3/8" ID x 2" OD x 3/4"	007455	2	
32	Bolt, 3/8-16 x 2 1/2" Hex Head Full Thread	F05007-157	2	
33	Washer, 3/8" Split Lock	F05011-4	2	
34	Nut, 3/8-16 Hex Jam	F05010--29	2	
35	Washer, 3/8" SAE Flat	F05011-3	4	
36	Nut, 3/8-16 Hex Lock	F05010-25	2	
37	Decal, SBE Clutch Operation	059481	1	
38	Decal, World Headquarters Info	015840	1	
39	Bracket, Clutch Rod	079516 ²	1	
40	Bolt, 5/16-18x1 3/4 Hex Head	F05009-70	4	
41	Washer, 5/16 SAE Flat	F05011-17	16	
42	Nut, 5/16-18 Nylok Hex	F05010-58	6	

¹ 062724 decal replaces 025754 EG50 Edger Logo Decal (5/11).

² Added 079516 Clutch Rod Bracket to provide a new location to hang the clutch rod while the engine assembly is removed (Rev. A2.02). Also, modified 007172 Clutch Pivot Bracket (welded to 007154 Peg Frame) to restore full travel of clutch handle.

5 Replacement Parts

Frame Assembly

5.3 Frame Assembly

SBEG10 Rev. A1.00 - A1.02

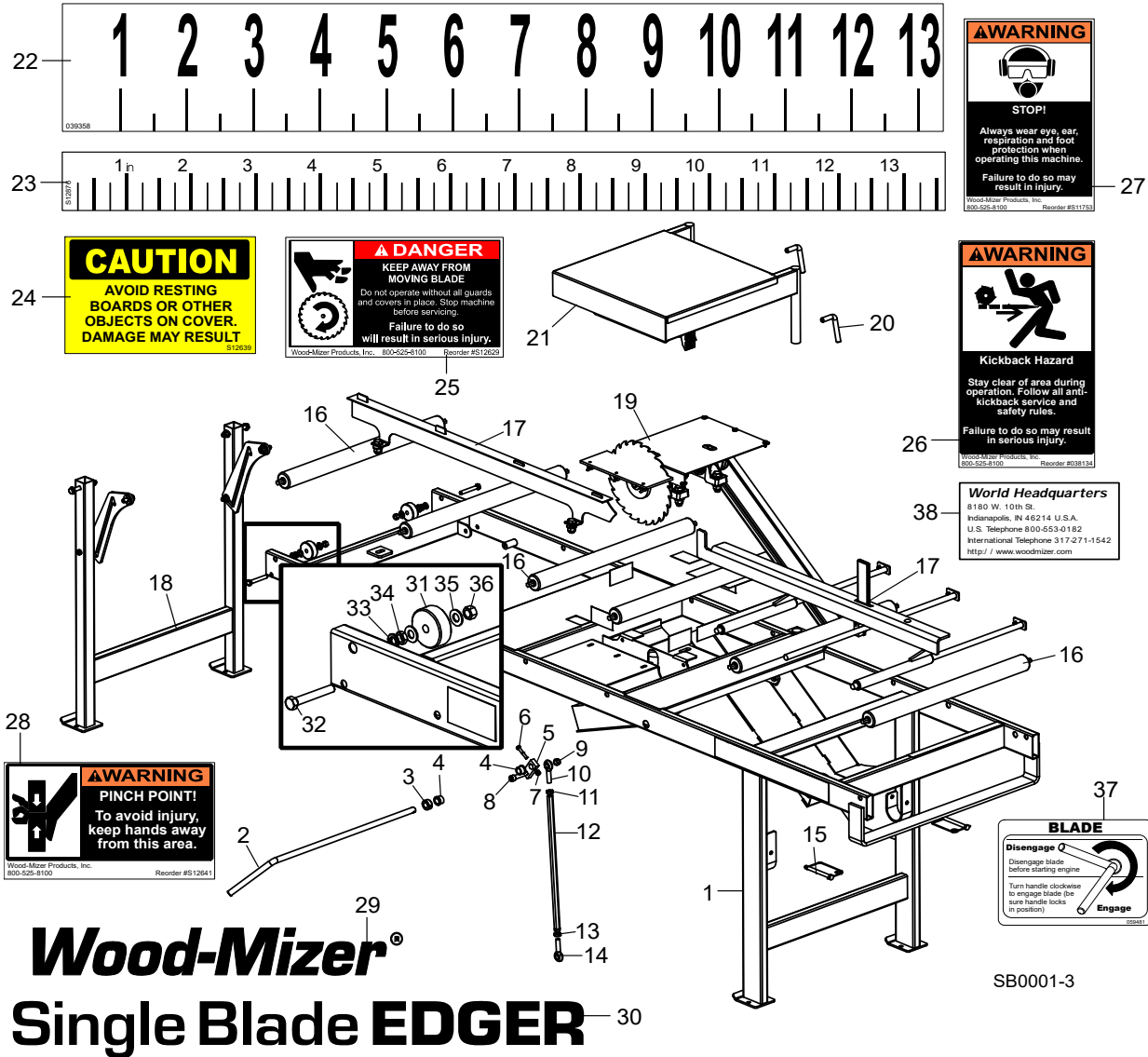

REF	DESCRIPTION (◆ Indicates Parts Available In Assemblies Only)	PART NUMBER	QTY.	
	EDGER, SINGLE BLADE BASE	007180	1	
	Frame Assembly, Single Blade Edger	007176	1	◆
1	Frame Weldment, Single Blade Edger	007154	1	◆
2	Handle, Edger Clutch	007179	1	
3	Collar, 5/8" ID Lock	P05035	1	
4	Bushing, 5/8" ID x 7/8" OD x 1/2" Bronze	P05135	2	
5	Block, Edger Clutch	007178	1	
6	Bolt, 1/4-20 x 1 1/2" Hex Head Grade 5	F05005-124	1	
7	Nut, 1/4-20 Hex Nylon Lock	F05010-69	1	

8	Screw, 7/16-20 x 1 1/2" Socket Head	F05007-120	1	
9	Nut, 7/16-20 Hex Nylon Lock	F05010-83	1	
	Turnbuckle Assembly, Edger Clutch	007197	1	
10	Rod End, 7/16-20 Right Hand Male	P11579	1	
11	Nut, 7/16-20 Hex Jam	F05010-38	1	
12	Turnbuckle, Edger Clutch	007196	1	
13	Nut, 7/16-20 Left Hand Hex Jam	F05010-87	1	
14	Rod End, 7/16-20 Left Hand Male	P11578	1	
15	Pin, 3/8" x 3 1/2" Retaining	046411	2	
16	Roller, 24" Conveyor	007177	6	
17	Fence Parts (See Section 5.4)			
18	Rear Leg Parts (See Section 5.5)			
19	Blade System Parts (See Section 5.6)			
20	Handle, Top Guard Lock	S12676	2	
21	Top Blade Guard Parts (See Section 5.7)			
22	Decal, Edger Cover Inch Scale	039358	1	
	Decal, Edger Cover Metric Scale	S12662	1	
23	Decal, Fence Inch Scale	S12876	1	
	Decal, Fence Metric Scale	S12877	1	
24	Decal, Edger Cover Caution	S12639	1	
25	Decal, Moving Blade Danger	S12629	4	
26	Decal, Kickback Hazard Warning	038134	1	
27	Decal, Eye/Ear Warning	S11753	1	
28	Decal, Hand Pinch Warning	S12641	3	
29	Decal, 2 1/2" Wood-Mizer Logo	049401	2	
30	Decal, Single Blade Edger Logo	059474	2	
31	Roller, 3/8" ID x 2" OD x 3/4"	007455	2	
32	Bolt, 3/8-16 x 2 1/2" Hex Head Full Thread	F05007-157	2	
33	Washer, 3/8" Split Lock	F05011-4	2	
34	Nut, 3/8-16 Hex Jam	F05010-29	2	
35	Washer, 3/8" SAE Flat	F05011-3	4	
36	Nut, 3/8-16 Hex Lock	F05010-25	2	
37	Decal, SBE Clutch Operation	059481	1	
38	Decal, World Headquarters Info	015840	1	

5.4 Guide Fence Assembly

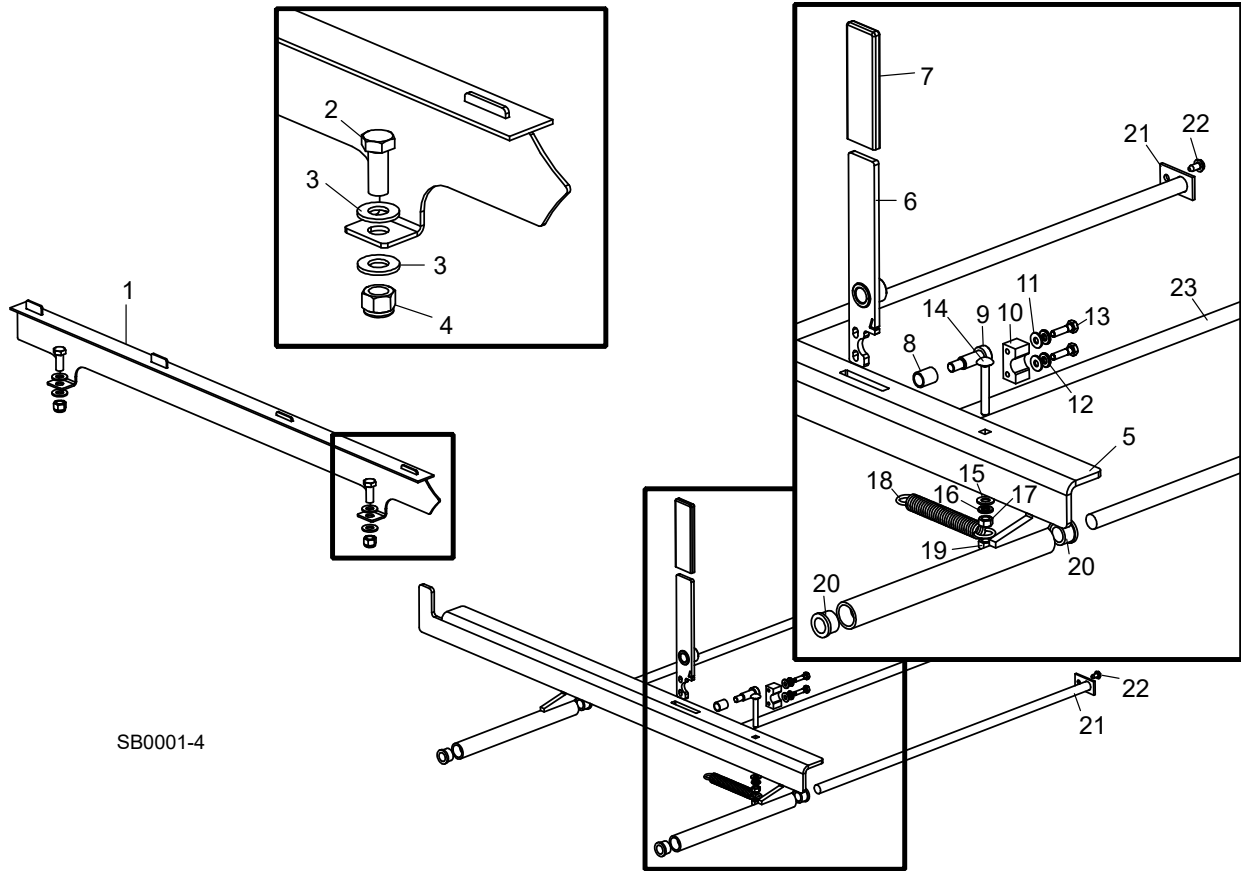

SB0001-4

REF	DESCRIPTION (◆ Indicates Parts Available In Assemblies Only)	PART NUMBER	QTY.
1	FENCE WELDMENT, REAR T-BAR	007305	1
2	BOLT, 1/2-13 X 1 1/4" HEX HEAD	F05008-37	2
3	WASHER, 1/2" SAE FLAT	F05011-2	4
4	NUT, 1/2-13 HEX NYLON LOCK	F05010-8	2
	FENCE ASSEMBLY, SINGLE BLADE EDGER	007298	1
5	Fence Weldment, Single Blade Edger	007297	1
6	Handle Weldment, Edger Fence	007301	1
7	Cover, Fence Handle	016726	1
8	Bushing, 1/2" ID x 5/8" OD x 3/4" Bronze	046976	1
9	Bolt, 1/2" x 1" Shoulder Socket Head	F05008-146	1
10	Block, Edger Fence Pivot	007302	1
11	Washer, 1/4" SAE Flat	F05011-60	2
12	Washer, 1/4" Split Lock	F05011-14	2
13	Bolt, 1/4-20 x 1" Hex Head Grade 5	F05005-101	2
14	Bolt, 5/16-18 x 2 1/4" Full Thread Carriage Head	F05006-61	1
15	Washer, 5/16" SAE Flat	F05011-17	1
16	Washer, 5/16" Split Lock	F05011-13	1

17	Nut, 5/16-18 Hex	F05010-17	1	
18	Spring, Edger Front Fence	P04060	1	
19	Nut, 5/16-18 Hex Lock	F05010-6	1	
20	Bushing, 5/8" ID x 7/8" OD x 1/2" Bronze	P05135	4	
21	SHAFT WELDMENT, EDGER FENCE	007290	2	
22	BOLT, 1/4-20 X 1/2" SELF-TAPPING HEX HEAD	F05015-1	3	
23	SHAFT WELDMENT, EDGER SETWORKS	007292	1	

5 Replacement Parts

Rear Leg Assembly

5.5 Rear Leg Assembly

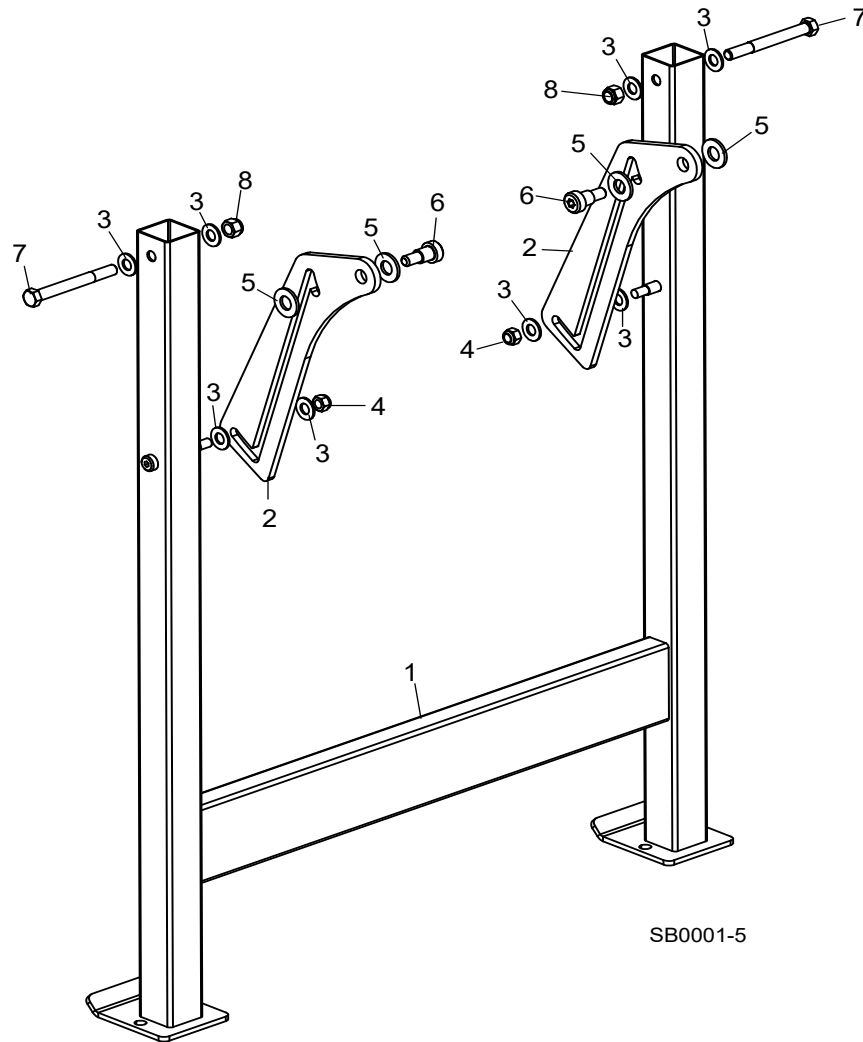

REF	DESCRIPTION (◆ Indicates Parts Available In Assemblies Only)	PART NUMBER	QTY.
1	LEG WELDMENT, EDGER REAR	007183	1
2	PLATE, REAR LEG LOCK	007184	2
3	WASHER, 3/8" SAE FLAT	F05011-3	8
4	NUT, 5/16-18 HEX NYLON LOCK	F05010-58	2
5	WASHER, 1/2" SAE FLAT	F05011-2	4
6	BOLT, 3/8"-16 X 1/2" SHOULDER SOCKET HEAD	F05008-63	2
7	BOLT, 3/8-16 X 3 1/2" HEX HEAD	F05004-123	2
8	NUT, 3/8-16 HEX NYLON LOCK	F05010-10	2

5.6 Blade Assembly

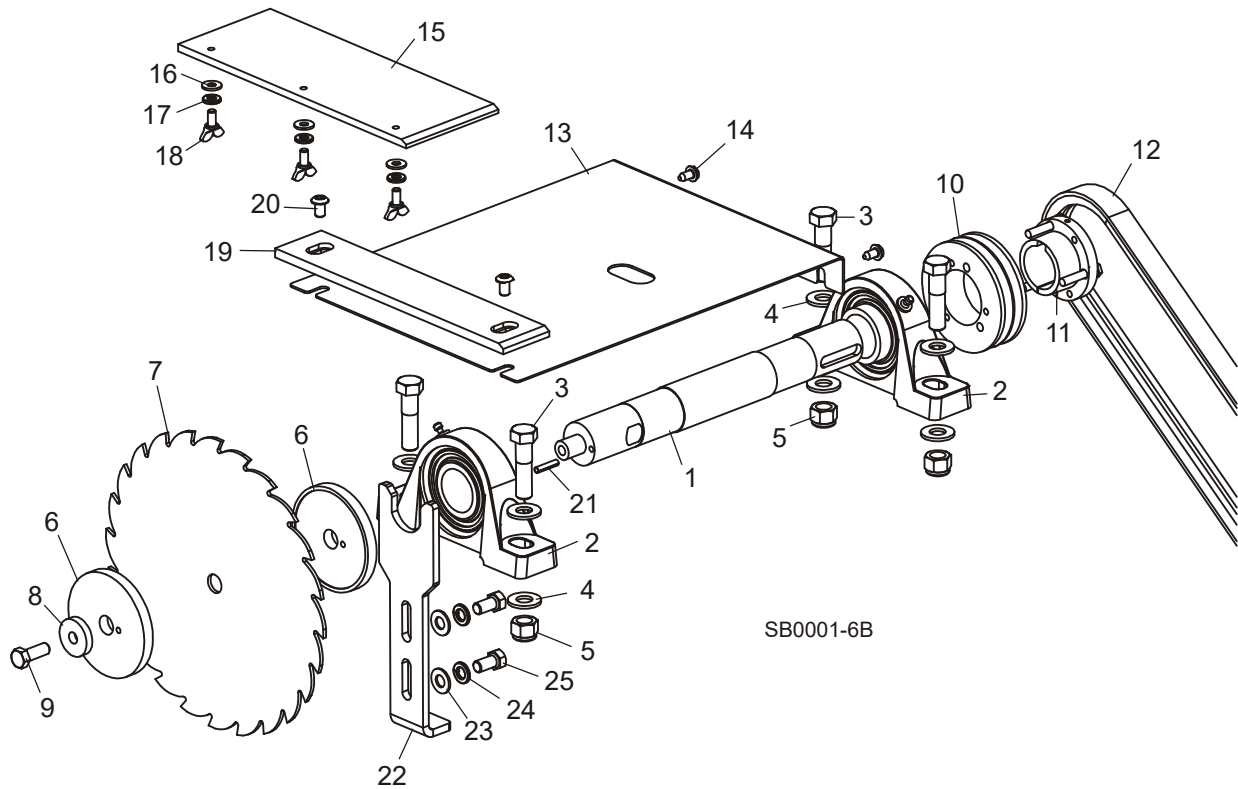

REF	DESCRIPTION (◆ Indicates Parts Available In Assemblies Only)	PART NUMBER	QTY.
1	SHAFT, EDGER BLADE	007185	1
2	BEARING, 1 7/16" BORE PILLOW BLOCK	P07981-1	2
3	BOLT, 1/2-13 X 2" HEX HEAD GRADE 5	F05008-102	4
4	WASHER, 1/2" SAE FLAT	F05011-2	8
5	NUT, 1/2-13 HEX NYLON LOCK	F05010-8	4
6	RETAINER, EDGER BLADE	007186	2
7	BLADE, 10"-24T .8" KERF	025916 ¹	1
8	WASHER, 3/8" ID X 1 1/4" OD	S02779	1
9	BOLT, 3/8-16 X 1" LEFT HAND HEX HEAD GRADE 5	F05007-227	1
10	SHEAVE, 3V3.65X2 SH	007194	1
11	BUSHING, SH X 1 7/16"	016535	1
12	BELT, 2/3VX600	007195	1
13	COVER, EDGER BLADE BEARING	065569 ²	1
14	BOLT, 1/4-20 X 1/2" SELF-TAPPING HEX HEAD	F05015-1	2
15	PLATE, BLADE FILLER	007199	1
16	WASHER, 1/4" SAE FLAT	F05011-11	3
17	WASHER, 1/4" SPLIT LOCK	F05011-14	3
18	BOLT, 1/4-20 X 1/2" WING	F05005-16	3
19	PLATE, BLADE FILLER INSIDE	065570 ²	1

5**Replacement Parts***Blade Assembly*

20	BOLT, 5/16-18 X 1/2" SBH	F05006-20	2	
21	PIN, 3/16" X 7/8" ROLL	F05012-19	1	
22	LOCK, BLADE SHAFT	065571 ²	1	
23	BOLT, 3/8-16 X 3/4" HEX HEAD GRADE 2	F05007-27	2	
24	WASHER, 3/8" SPLIT LOCK	F05011-4	2	
25	WASHER, 3/8" FLAT SAE	F05011-3	2	

¹ Blade 025916 replaces 007187 Rev. A1.03. New blade has wider kerf to eliminate binding with rear T-bar.

² 065569 replaced 007198 Blade Bearing Cover; inside Blade Retaining Washer (007186) pinned to blade shaft with F05012-19 Roll Pin; 065571 Blade Shaft Lock and 065570 Blade Filler Inside Plate added (Rev. A2.00).

5.7 Blade Cover Assembly

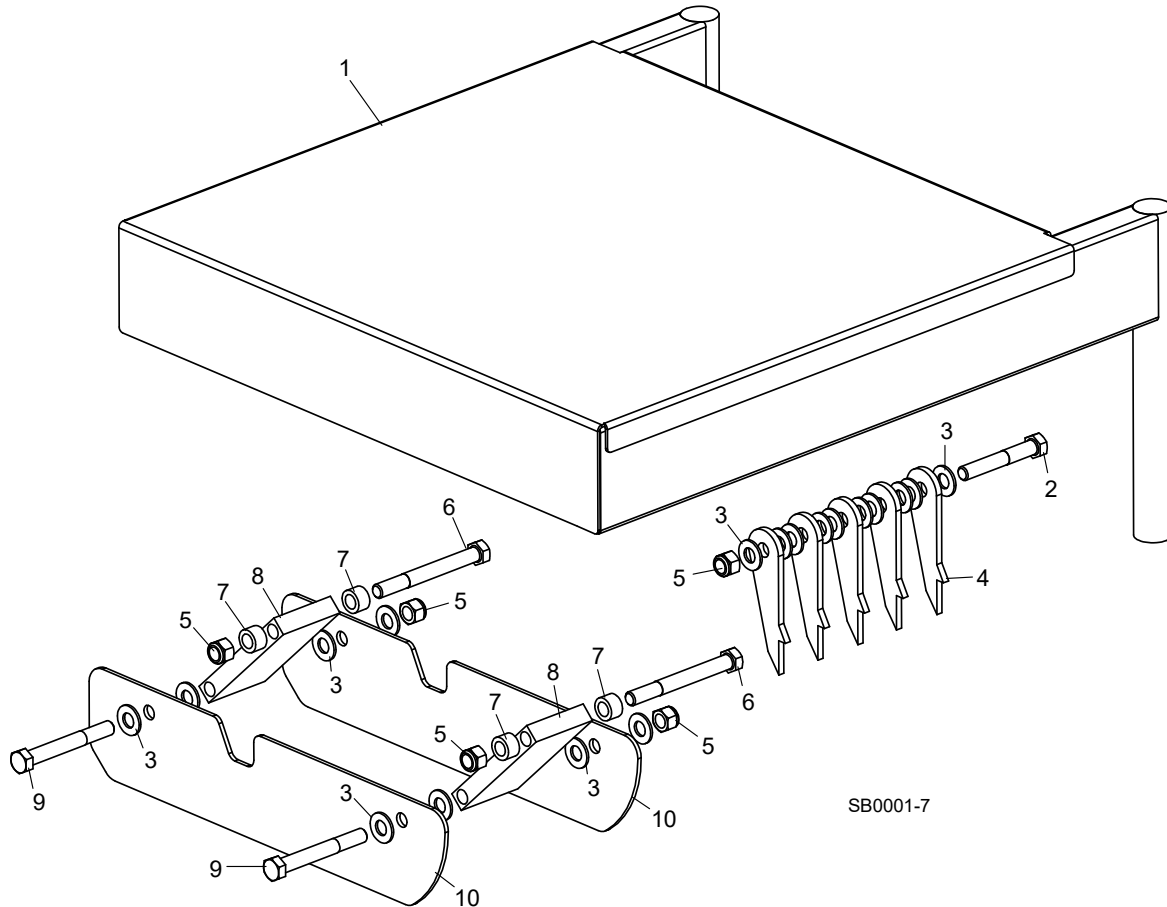

SB0001-7

REF	DESCRIPTION (◆ Indicates Parts Available In Assemblies Only)	PART NUMBER	QTY.
	COVER ASSEMBLY, EDGER BLADE	007314	1
1	Cover Weldment, Edger Blade	007313	1
2	Bolt, 3/8-16 x 2 1/2" Hex Head Grade 5	F05007-125	1
3	Washer, 3/8" SAE Flat	F05011-3	18
4	Plate, Edger Kickback Finger	007317	5
5	Nut, 3/8-16 Hex Nylon Lock	F05010-10	5
6	Bolt, 3/8-16 x 3 1/2" Hex Head	F05004-123	2
7	Spacer, .39" ID x .625" OD x .39"	055323	4
8	Plate, Edger Cover Link	007315	2
9	Bolt, 3/8-16 x 3" Hex Head Grade 5	F05007-73	2
10	Plate, Edger Blade Guard	007316	2

5.8 Engine Assembly

Rev. A1.02+

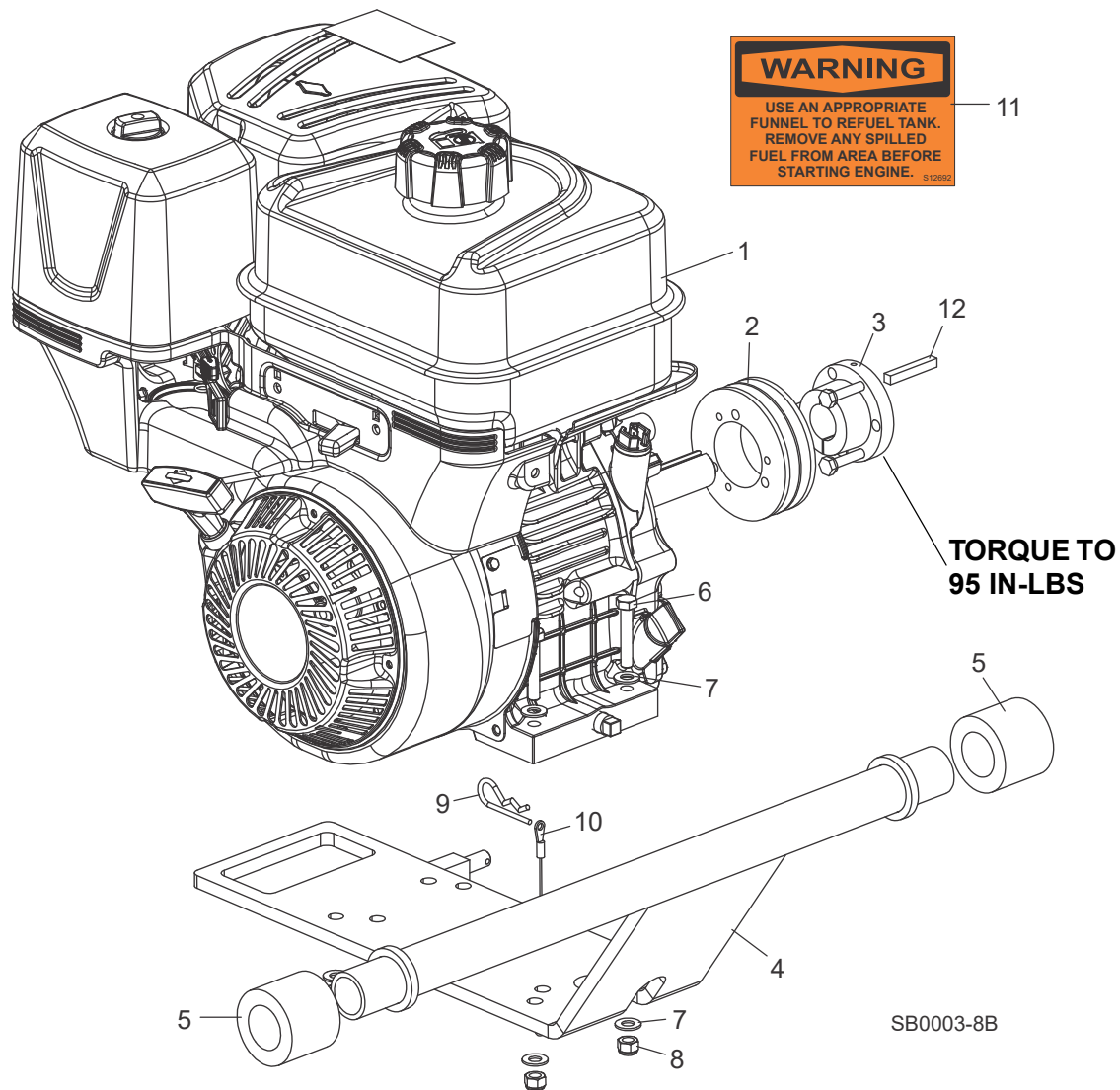

REF	DESCRIPTION (◆ Indicates Parts Available In Assemblies Only)	PART NUMBER	QTY.
	ENGINE ASSEMBLY, 10HP EDGER	007192	1
1	Engine, 10HP Briggs Gas #2053320246B1	057862 ¹	1
	Magneto, Briggs #492341	061754	1
	Filter, Air Briggs #491588S	039426	1
	Pre-Cleaner, Air Briggs #491435S	061755	1
	Plug, Spark Briggs #491055S	039423	1
2	Sheave, 3V3.65x2 SH	007194	1
3	Bushing, SH x 1"	039202	1
4	Mount Weldment, Edger Engine	007191 ²	1
5	Bushing, 1 1/4" ID x 2 1/8" OD x 1 3/4" Rubber	P12164	2

6	Bolt, 5/16-18 x 1 3/4" Hex Head Full Thread Grade 5	F05006-81	4	
7	Washer, 5/16" SAE Flat	F05011-17	8	
8	Nut, 5/16-18 Hex Nylon Lock	F05010-58	4	
9	Pin, 1/8" x 1 13/16" Safety	P05059	1	
10	Lanyard, 3/64" x 6"	016030	1	
11	Decal, Engine Refuel Warning	S12692	1	
12	Key, 1/4 x 1 11/16	S04124	1	

¹ Engine changed to new 10HP Briggs Vanguard Engine Specification (Rev. A2.01). Updated 007191 to move by 7/16" for clutch linkage clearance around engine muffler guard plate.

² Mount Weldment 007191 modified to eliminate need for spacer blocks 007598 (Rev. A1.02). [See Section 5.9](#) for mounting hardware on previous revisions.

5.9 Engine Assembly

Rev. A1.01

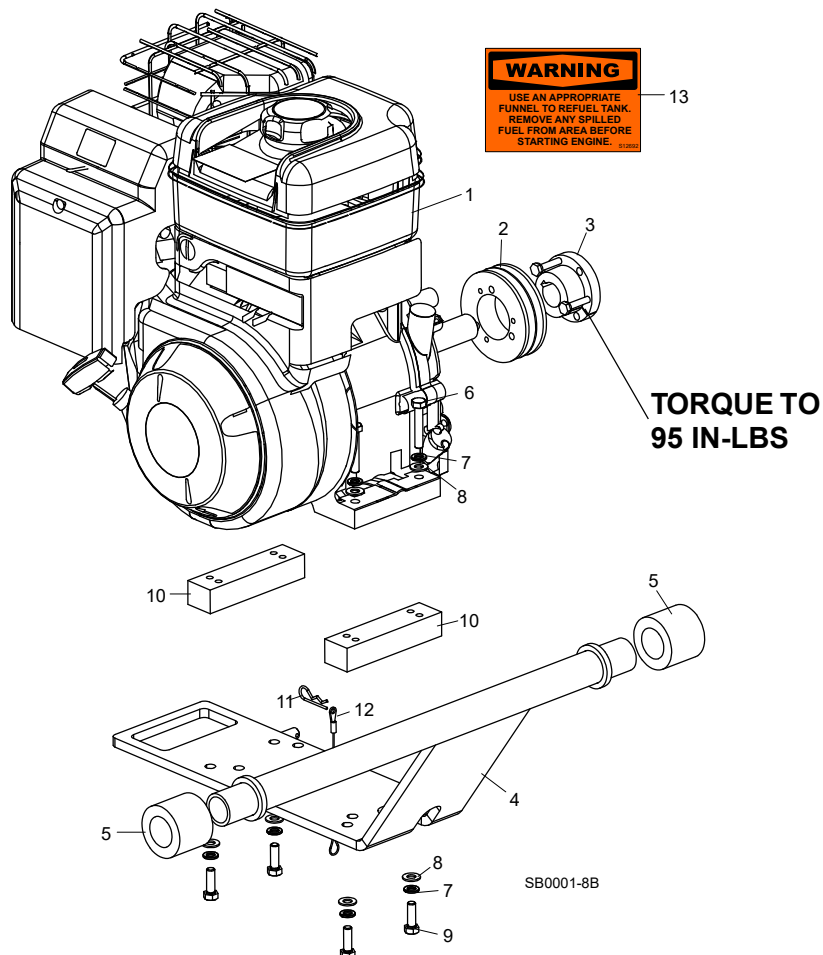

REF	DESCRIPTION (◆ Indicates Parts Available In Assemblies Only)	PART NUMBER	QTY.
	ENGINE ASSEMBLY, 10HP EDGER	007192 ¹	1
1	Engine, 10HP Briggs Gas #2053320246B1	057862	1
	Magneto, Briggs #492341	061754	1
	Filter, Air Briggs #491588S	039426	1
	Pre-Cleaner, Air Briggs #491435S	061755	1
	Plug, Spark Briggs #491055S	039423	1
2	Sheave, 3V3.65x2 SH	007194	1
3	Bushing, SH x 1"	039202	1
4	Mount Weldment, Edger Engine	007191 ¹	1
5	Bushing, 1 1/4" ID x 2 1/8" OD x 1 3/4" Rubber	P12164	2
6	Bolt, 5/16-18 x 1 3/4" Hex Head Full Thread Grade 5	F05006-81	4
7	Washer, 5/16" Split Lock	F05011-13	8
8	Washer, 5/16" SAE Flat	F05011-17	8
9	Bolt, 5/16-18 x 1" Hex Head Grade 5	F05006-27	4

10	Block, SBE Motor Mount Spacer	007598 ¹	2	
11	Pin, 1/8" x 1 13/16" Safety	P05059	1	
12	Lanyard, 3/64" x 6"	016030	1	
13	Decal, Engine Refuel Warning	S12692	1	

¹ Engine Assembly 007192 modified 9/09 with revised Mount Weldment 007191 to eliminate need for spacer blocks 007598 ([See Section 5.8](#)).

INDEX

M

maintenance
blade system 4-3
drive system 4-1
feed table rollers 4-2

R

replacement parts
blade assembly 5-9
blade cover 5-11
edger 5-1
engine 5-12, 5-14
frame 5-2, 5-4
guide fence 5-6
rear leg 5-8

S

safety
instructions 2-2
symbols 2-1

service information
branch locations 1-3
customer & equipment ID 1-5
general contact info 1-2
specifications 1-4

setup & operation
alignment 3-5
operation 3-8
setup 3-1
transporting 3-10