

Industrial Edger
Safety, Operation & Parts Manual

EG400EC30

rev. A5.03

Safety is our #1 concern!

Form #1110



WARNING! Read and understand this manual before using this machine.

California
Proposition 65 Warning



WARNING: Breathing gas/diesel engine exhaust exposes you to chemicals known to the State of California to cause cancer and birth defects or other reproductive harm.

- Always start and operate the engine in a well-ventilated area.
- If in an enclosed area, vent the exhaust to the outside.
- Do not modify or tamper with the exhaust system.
- Do not idle the engine except as necessary.

For more information go to **www.P65warnings.ca.gov**.



WARNING: Drilling, sawing, sanding or machining wood products can expose you to wood dust, a substance known to the State of California to cause cancer. Avoid inhaling wood dust or use a dust mask or other safeguards for personal protection.

For more information go to **www.P65Warnings.ca.gov/wood**.

Active Patents assigned to Wood-Mizer, LLC

Wood-Mizer, LLC has received patents that protect our inventions which are a result of a dedication to research, innovation, development, and design. Learn more at: woodmizer.com/patents

©2022 Wood-Mizer LLC

Printed in the United States of America, all rights reserved. No part of this manual may be reproduced in any form by any photographic, electronic, mechanical or other means or used in any information storage and retrieval system without written permission from

Wood-Mizer, LLC
8180 West 10th Street
Indianapolis, Indiana 46214

INTRODUCTION

1.1	About This Manual	1-1
1.2	Getting Service.....	1-1
1.3	Specifications	1-1

1.1	Dimensions.....	1-2
-----	-----------------	-----

SAFETY

2.1	Safety Symbols	2-3
2.2	Safety Instructions.....	2-4
2.3	Electrical Lockout Procedures	2-6

SETUP AND OPERATION

3.1	Setup.....	3-1
3.2	Electrical Installation	3-3
	<i>Electrical Requirements</i>	3-3
	<i>Installation</i>	3-4
3.3	Pre-Operation Check.....	3-8
3.4	Starting & Stopping The Machine	3-10
3.5	Edging Lumber	3-12
3.6	Setworks Setup & Operation (Optional).....	3-14
	<i>Setworks Calibration</i>	3-14
	<i>Setworks Enable/Disable</i>	3-14
	<i>Setworks Operation</i>	3-14
	<i>Setworks Programming</i>	3-15
3.7	Remote Operation (Optional).....	3-16

MAINTENANCE

4.1	Replacing the Blade Teeth	4-1
4.2	Changing the Blades	4-1
4.3	Tensioning the Belts.....	4-4
4.4	Tensioning the Chains.....	4-7
4.5	Feed Rate.....	4-10
4.6	Maintaining and Sharpening Anti-Kickback Fingers	4-11
4.7	Laser Guides Alignment	4-12
4.8	Maintenance Log.....	4-16

REPLACEMENT PARTS

5.1	How To Use The Parts List.....	5-1
	<i>To Order Parts</i>	5-1
5.2	Sample Assembly.....	5-1
5.3	Torque Values	5-2

5.1	Infeed Table Assembly	5-3
5.2	Blade and Laser Drives	5-5

Table of Contents

Section-Page

5.3	Laser Drive Motor.....	5-7
5.4	Laser Guides Housing.....	5-8
5.5	Laser Guides	5-10
5.6	Blades Assembly.....	5-11
5.7	Blades Shaft	5-13
5.8	Blades Motor Assembly.....	5-14
5.9	Feed Drive Assembly.....	5-15
5.10	Upper Driven Roller.....	5-17
5.11	Lower Drive Rollers.....	5-18
5.12	Upper Idle Roller	5-19
5.13	Tensioner Assembly.....	5-20
5.14	Kickback Assembly	5-21
5.15	Operator Control Assembly	5-22
5.16	Operator Control Assembly (w/Optional Setworks).....	5-24
5.17	Electrical Cabinet, Laser Interface & Harnesses	5-26
5.18	Frame Assembly	5-28
5.19	Housing Covers & Control Assembly	5-30
5.20	Top Blade Guard Assembly	5-31
5.21	Decals.....	5-32
5.22	Chute Assembly	5-33
5.23	Setworks Retrofit (Optional).....	5-34
5.24	Display Assembly (Optional).....	5-35
5.25	Transducer Assembly (Optional)	5-36
5.26	Transducer Cover Assembly (Optional)	5-37
5.27	Setworks Switch Assembly (Optional).....	5-38
5.28	Remote Assembly (Optional).....	5-39

ELECTRICAL INFORMATION

6.1	Electrical Symbol Diagram.....	6-1
6.2	Electrical Component List	6-7
6.3	Component Layout Diagrams	6-9
	<i>Control Cabinet/Laser Interface</i>	<i>6-9</i>
	<i>Operator Interface without Setworks</i>	<i>6-10</i>
	<i>Operator Interface with Setworks</i>	<i>6-10</i>

INDEX

I

Wood-Mizer® LLC Limited Product Warranty



Wood-Mizer LLC ("Warrantor"), an Indiana corporation with its principal place of business at 8180 West Tenth Street, Indianapolis, IN 46214-2400 USA, warrants to the purchaser ("Purchaser") that for the time periods specifically stated herein and subject to the terms, conditions and limitations stated herein, the equipment manufactured by the Warrantor will be free from defects in material and workmanship attributable to Warrantor so long as, during the warranty periods stated herein, the equipment is installed, operated and maintained in accordance with the instructions provided by Warrantor.

PRODUCT	MODEL CLASS	LENGTH OF WARRANTY		EFFECTIVE DATE
		USA & CANADA	NON USA & CANADA	
Portable Sawmills, Resaws, Edgers	LT, LX, HR, EG	Two years	One year	Date of purchase
Portable Sawmills with Chassis	LT28, LT35, LT40, LT50, LT70, LX450	Two years, excluding the chassis, which chassis shall have a five year warranty	One year	
Industrial Sawmills, Resaws, Edgers	WM, HR, EG, TVS, SVS	One year	One year	Date of purchase or date of installation / training (if applicable), whichever occurs first, not to exceed 6 months from date of purchase
TITAN Industrial	WB, TV, HR, EG, EA, MR	One year	One year	
Material Handling	TWC, IC, TD, LD, GC, CR, CB, CC	One year	One year	
Blade Maintenance Equipment	BMS, BMT, BMST	One year	One year	Date of purchase
Options and Accessories	Various	One year*	One year*	
Moulders, Extractors	MP, MD	Two years	One year	
Kilns	KS, KD	One year	One year	
Slab Flattener	MB	Two years	One year	
Pallet Equipment	PD, PC	One year	One year	
Log Splitters	FS	One year	One year	
Replacement Parts	Various	90 days	90 days	

* Warranty on Options will match the warranty on the primary equipment when purchased on same invoice.

Exclusions from 90 Day, Limited One Year and Two Year Warranty

Warrantor shall have **no** responsibility under this warranty for any wear components, including, but not limited to: belts, blade guides, blades, electric motor brushes, drum switches, filters, fuses, hoses, bearings (excluding cylindrical drive bearings), bushings, cable carriers, and spark plugs. All wear components are furnished "as is", without any warranty from Warrantor. This limited warranty does not cover any defects caused by misuse, negligence, alterations, damage due to overload, abnormal conditions, excessive operation, accident, or lack of performance of normal maintenance services.

Several components which are used in the manufacture of the equipment but not manufactured by Warrantor such as cant hooks, power plants, laser sights, batteries, tires, and trailer axles have warranties provided by the original equipment manufacturer (written copies available upon request). Warrantor does not separately warrant such items. Components or equipment manufactured by third parties are not covered by this warranty. Warrantor, however, will provide reasonable assistance to the Purchaser to make claims against any warranties applicable to such component parts as provided by such original equipment manufacturers. Components or equipment manufactured by third parties are not covered by this Warranty.

Five Year Limited Chassis Warranty

The limited five year chassis warranty described above, DOES NOT extend to (a) any damage stemming from accident, improper towing, overload, abuse, misuse, abnormal conditions, negligence, excessive operation, or lack of maintenance, (b) rust caused by exposure to corrosive atmospheric conditions, or (c) the sawmill head, carriage, axle, brakes, or any hydraulic or electrical components attached to the chassis.

Warrantor's Obligations as To Defects

In the event that the equipment fails to perform due to defective materials or workmanship attributable to Warrantor under normal use and service within the established warranty period, Purchaser's sole and exclusive remedy and Warrantor's sole liability shall be to replace or repair, in Warrantor's sole and subjective discretion, any defective part at Warrantor's principal place of business without cost to the Purchaser if such defect exists. The determination of whether a product is defective shall be made by Warrantor in Warrantor's sole and subjective discretion. The Purchaser must notify Warrantor prior to shipping any defective part. Warrantor, at its sole discretion, may cover expenses incurred in shipping the defective part to Warrantor for evaluation; provided, however, that Warrantor will not be responsible for labor, travel time, mileage, removal, installation or incidental or consequential damages. However, any part in excess of 140 pounds must be returned by the Purchaser, to the Warrantor's nearest authorized facility at the Purchaser's expense, if return is requested by Warrantor. Warrantor shall have a reasonable time within which to replace or repair the defective part. If Warrantor determines that the product is not defective under the terms of this warranty in Warrantor's sole and subjective discretion, then Purchaser shall be responsible for any expenses incurred by Warrantor in returning the equipment to the Purchaser.

Limitations and Disclaimers of Other Warranties

EXCEPT FOR THE EXPRESS WARRANTY PROVISIONS STATED ABOVE, WARRANTOR DISCLAIMS ALL WARRANTIES, EXPRESS AND/OR IMPLIED, INCLUDING WITHOUT LIMITATION, THE IMPLIED WARRANTIES OF MERCHANTABILITY, AND FITNESS FOR A PARTICULAR PURPOSE, NON-INFRINGEMENT AND TITLE. No representation or other affirmation of fact by representatives of Warrantor, whether verbal or in writing, including photographs, brochures, samples, models, or other sales aids, shall constitute a warranty or other basis for any legal action against Warrantor. There are no other representations, promises, agreements, covenants, warranties, guarantees, stipulations or conditions, express or implied, by Warrantor except as expressly set forth herein. THE ORIGINAL PURCHASER AND ANY INTENDED USER OR BENEFICIARY OF THIS EQUIPMENT, SHALL NOT BE ENTITLED TO RECOVER ANY INDIRECT, SPECIAL, PUNITIVE, EXEMPLARY, CONSEQUENTIAL, SPECIAL, OR INCIDENTAL DAMAGES OR LOSSES, INCLUDING BUT NOT LIMITED TO, DAMAGES OF LOST PRODUCTION, LOST REVENUE, LOST PRODUCT, LOST PROFITS, LOST BUSINESS, LOSS OF USE, LOSS OF GOODWILL, OR BUSINESS INTERRUPTION, FROM WARRANTOR FOR ANY REASON WHATSOEVER INCLUDING WITHOUT LIMITATION WARRANTY OR DEFECT IN THE PRODUCT REGARDLESS OF THE SOLE, JOINT AND/OR CONCURRENT NEGLIGENCE, BREACH OF CONTRACT, BREACH OF WARRANTY, STRICT LIABILITY IN TORT OR STATUTORY CLAIMS OR OTHER LEGAL FAULT OR RESPONSIBILITY OF EITHER WARRANTOR OR PURCHASER OR ITS EMPLOYEES OR AGENTS. Warrantor does not warrant that its equipment meets or complies with the requirements of any particular safety code or governmental requirements.

Defective items replaced under the terms of this warranty become the property of Warrantor.

Design Changes

Warrantor reserves the right to change the design of its products from time to time without notice and without obligation to make corresponding changes in or to its products previously manufactured.

Rights of Purchasers

The validity and effect of this limited warranty as well as its interpretation, operation and effect, shall be determined exclusively by the principles of law and equity of the State of Indiana, USA. This limited warranty gives Purchaser specific legal rights. Purchaser may also have other rights, which may vary from state to state. Some states may not allow limitations as to the duration of implied warranties or to the exclusion or limitation of incidental or consequential damages, so some of the limitations and exclusions detailed set forth above may not apply. In the event that any one or more of the provisions of this warranty shall be or become invalid, illegal or unenforceable in any respect, the validity, legality and enforceability of the remaining provisions of this warranty shall not be affected thereby.

Interpretations

This Warranty constitutes the entire warranty agreement between Warrantor and Purchaser and supersedes any prior understandings or agreements pertaining to the same subject matter. This warranty cannot be amended except in writing which refers to this warranty which is signed by both Warrantor and Purchaser.

SECTION 1 INTRODUCTION

1.1 About This Manual

This manual replaces any previous information received on your Wood-Mizer® equipment.

The information and instructions in this manual do not amend or extend the limited warranties for the equipment given at the time of purchase.

1.2 Getting Service

For contact information, sales, service, parts, and additional manuals, sign into your account on <https://woodmizer.com>, or call inside the USA: 1-800-553-0182 or from outside the USA: 317-271-1542

1.3 Specifications

Equipment specification are included in the Online Manuals, which are found at <https://apps.woodmizer.com/Manuals/Manuals.aspx?parent=0>.

SECTION 1

1.1 Dimensions

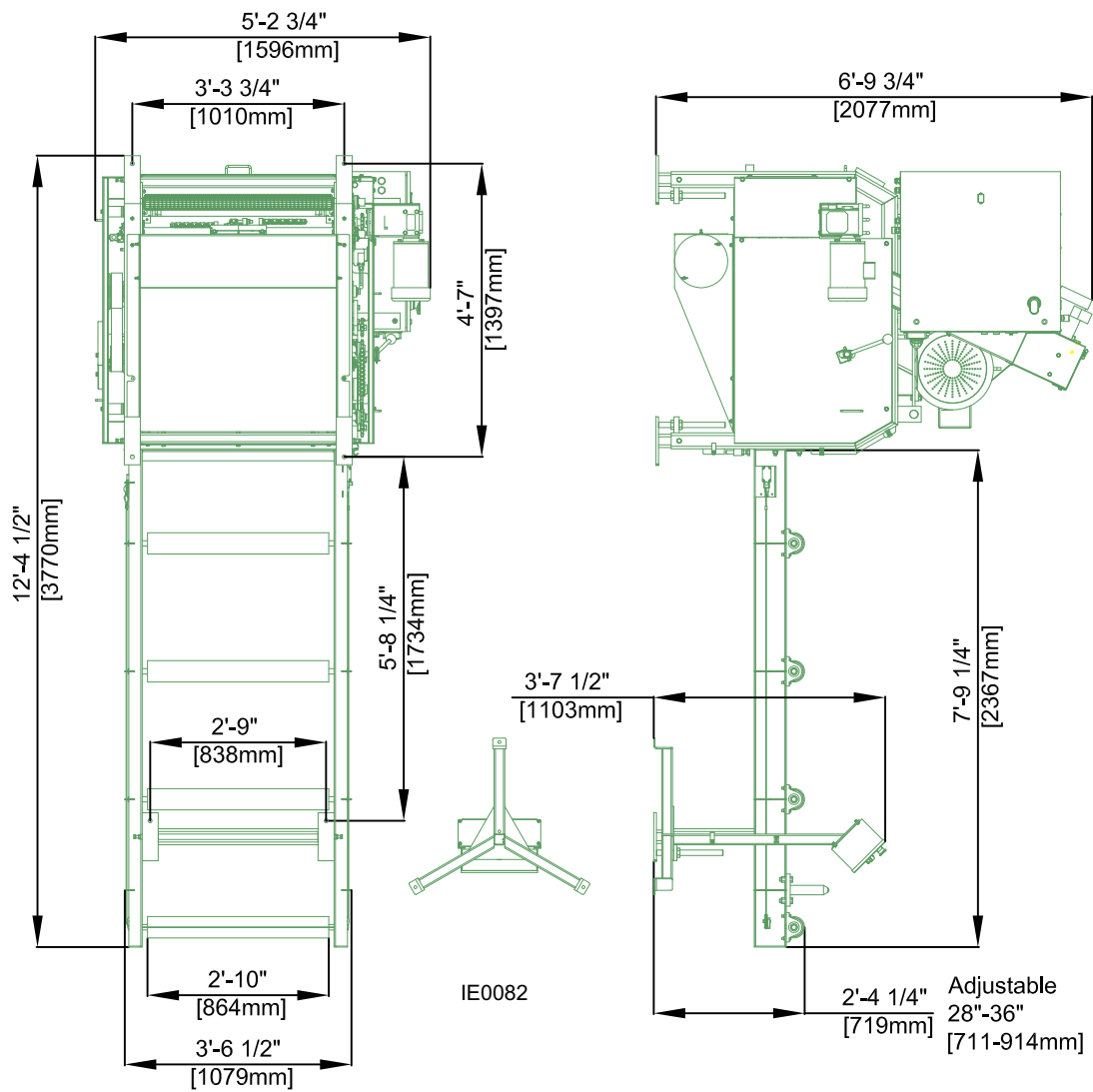

INDUSTRIAL EDGER DIMENSIONS

SECTION 2 SAFETY

2.1 Safety Symbols

The following symbols and signal words call your attention to instructions concerning your personal safety. Be sure to observe and follow these instructions.



DANGER! indicates an imminently hazardous situation which, if not avoided, will result in serious injury or death.



WARNING! suggests a potentially hazardous situation which, if not avoided, could result in serious injury or death.



CAUTION! refers to potentially hazardous situations which, if not avoided, may result in minor or moderate injury or damage to equipment.

NOTICE indicates vital information.

2.2 Safety Instructions

NOTE: ONLY safety instructions regarding personal injury are listed in this section. Caution statements regarding only equipment damage appear where applicable throughout the manual.

OBSERVE SAFETY INSTRUCTIONS

NOTICE Read the entire Owner's Manual before operating the Edger. Take notice of all safety warnings throughout this manual and those posted on the machine. Keep this manual with this machine at all times, regardless of ownership.

Also read any additional manufacturer's manuals and observe any applicable safety instructions including dangers, warnings, and cautions.

Only persons who have read and understood the entire operator's manual should operate the Edger. The Edger is not intended for use by or around children.

NOTICE It is always the owner's responsibility to comply with all applicable federal, state and local laws, rules and regulations regarding the ownership and operation of your Wood-Mizer Edger. All Wood-Mizer owners are encouraged to become thoroughly familiar with these applicable laws and comply with them fully while using the Edger.



WEAR SAFETY CLOTHING



WARNING! Secure all loose clothing and jewelry before operating the Edger. Failure to do so may result in serious injury or death.

WARNING! Always wear eye, ear, respiration, and foot protection when operating or servicing the Edger.



KEEP EDGER AND AREA AROUND EDGER CLEAN



DANGER! Maintain a clean and clear path for all necessary movement around the Edger and lumber stacking areas. Failure to do so will result in serious injury.

DISPOSE OF SAWING BY-PRODUCTS PROPERLY



WARNING! Clean sawdust from all guards, vents, control boxes, or any area where sawdust may gather after every shift. Failure to do so may result in fire, causing death or serious injury.



NOTICE Always properly dispose of all sawing by-products, including sawdust and other debris, coolant, oil, fuel, oil filters and fuel filters.

CHECK EDGER BEFORE OPERATION



DANGER! Make sure all guards and covers are in place and secured before operating the Edger.



WARNING! Check for proper rotation of the blades before operating the machine. Failure to do so may result in serious injury and/or machine damage.

WARNING! Always shut off the machine to stop the blade whenever the Edger is not in use.

WARNING! Do not for any reason adjust the drive belts with the machine running.

WARNING! Always ensure that there is a sharp point on the anti-kickback fingers before each use of the Edger.

Be sure anti-kickback fingers are free from obstruction and are in a downward position with lever released.

WARNING! Always check the control box mounted and cable activated Emergency Stop switches for proper operation prior to each use of the machine.



KEEP PERSONS AWAY



DANGER! Keep all persons out of the path of moving equipment and boards when operating the Edger. Failure to do so will result in serious injury.

KEEP HANDS AWAY

DANGER! Moving Parts Can Crush and Cut. Keep hands clear. Make sure all guards and covers are in place and secured before operating or towing.

DANGER! Always be aware of and take proper protective measures against rotating shafts, pulleys, sprockets, etc. Always stay a safe distance from rotating members and make sure that loose clothing or long hair does not engage rotating members resulting in possible injury.



WARNING! Coastdown Required. Always shut down the edger and allow all moving parts to come to a complete stop before removing any guards or covers. Do NOT operate with any guards or covers removed.

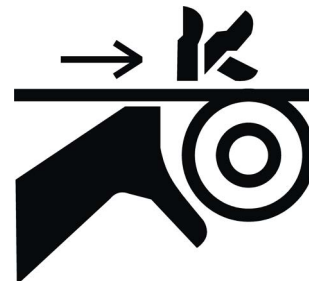

WARNING! Kickback Hazard. Stay clear of area during operation. Follow all anti-kickback service and safety rules.



USE PROPER PROCEDURE WHEN CONDUCTING ELECTRICAL SAFETY CHECKS AND MAINTENANCE



DANGER! Make sure all electrical installation, service and/or maintenance work is performed by a qualified electrician and is in accordance with applicable electrical codes.

DANGER! ARC FLASH AND SHOCK HAZARD! Hazardous voltage inside the electric sawmill disconnect box, starter box, and at the motor can cause shock, burns, or death. Disconnect and lock out power supply before servicing! Keep all electrical component covers closed and securely fastened during edger operation. Wear appropriate Personal Protection Equipment.

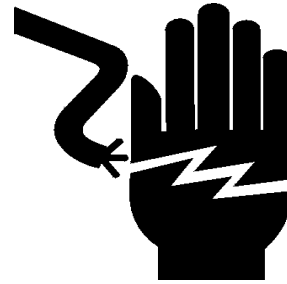

WARNING! Consider all electrical circuits energized and dangerous.

WARNING! Never assume or take the word of another person that the power is off; check it out and lock it out.

WARNING! Do not wear rings, watches, or other jewelry while working around an open electrical circuit.

KEEP SAFETY LABELS IN GOOD CONDITION

NOTICE Ensure that all safety decals are clean and readable. Replace all damaged safety decals to prevent personal injury or damage to the equipment. Contact your local distributor, or call your Customer Service Representative to order more decals.

NOTICE If replacing a component which has a safety decal affixed to it, make sure the new component also has the safety decal affixed.

2.3 Electrical Lockout Procedures

RULES FOR USING LOCKOUT PROCEDURE

The sawmill shall be locked out to protect against accidental or inadvertent operation when such operation could cause injury to personnel. Do not attempt to operate any switch or valve bearing a lock.

LOCKOUT PROCEDURES MUST BE USED DURING:

Changing or adjusting blades
Unjamming operations
Cleaning
Mechanical repair

Electrical maintenance
Retrieval of tools/parts from work area
Activities where guards or electrical panel guard is open or removed

MAINTENANCE HAZARDS INCLUDE:

Blade contact	Missiles (thrown blades/wood chips)
Pinch points	Electrical
Kickbacks	

FAILURE TO LOCKOUT MAY RESULT IN:

Cut	Serious injury and death
Crush	Amputation
Blindness	Burn
Puncture	Shock
Electrocution	

TO CONTROL MAINTENANCE DANGERS:

- Lockout procedures must be followed (see OSHA regulation 1910.147).
- Never rely on machine stop control for maintenance safety (emergency stops, on/off buttons, interlocks).
- Do not reach into moving blades or feed systems. Allow all coasting parts to come to a complete stop.
- Electrical power supply and air supply must both be locked out.
- Where established lockout procedures cannot be used (electrical troubleshooting or mechanical dynamic troubleshooting), alternative effective protective techniques shall be employed which may require special skills and planning.
- Always follow safe operations practices in the workplace.

SAWMILL LOCKOUT PROCEDURE

Lockout procedures per OSHA regulation 1910.147, appendix A:

GENERAL

The following simple lockout procedure is provided to assist owner/operators in developing their procedures so they meet the requirements of OSHA regulation 1910.147. When the energy isolating devices are not lockable, tagout may be used, provided the owner/operator complies with the provisions of the standard which require additional training and more rigorous periodic inspections. When tagout is used and the energy isolating devices are lockable, the owner/operator must provide full operator protection (see OSHA regulation 1910.147, paragraph (c)(3)) and additional training and more rigorous periodic inspections are required. For more complex systems, more comprehensive procedures may need to be developed, documented, and utilized.

PURPOSE

This procedure establishes the minimum requirements for the lockout of energy isolating devices whenever maintenance or servicing is done on machines or equipment. It shall be used to ensure that the machine or equipment is stopped, isolated from all potentially hazardous energy sources and locked out before personnel perform any servicing or maintenance where the unexpected energization or start-up of the machine or equipment or release of stored energy could cause injury.

COMPLIANCE WITH THIS PROGRAM

All personnel are required to comply with the restrictions and limitations imposed upon them during the use of lockout. The authorized personnel are required to perform the lockout in accordance with this procedure. All operators, upon observing a machine or piece of equipment which is locked out to perform servicing or maintenance shall not attempt to start, energize, or use that machine or equipment.

SEQUENCE OF LOCKOUT

1. Notify all affected personnel that servicing or maintenance is required on a machine or equipment and that the machine or equipment must be shut down and locked out to perform the servicing or maintenance.
2. The authorized employee shall refer to the company procedure to identify the type and magnitude of the energy that the machine or equipment utilizes, shall understand the hazards of the energy, and shall know the methods to control the energy.
3. If the machine or equipment is operating, shut it down by the normal stopping procedure (depress the stop button, open switch, close valve, etc.).

4. De-activate the energy isolating device(s) so that the machine or equipment is isolated from the energy source(s).
5. Lock out the energy isolating device(s) with assigned individual lock(s).
6. Stored or residual energy (such as that in capacitors, springs, elevated machine members, rotating flywheels, hydraulic systems, and air, gas, steam, or water pressure, etc.) must be dissipated or restrained by methods such as grounding, repositioning, blocking, bleeding down, etc.
7. Ensure that the equipment is disconnected from the energy source(s) by first checking that no personnel are exposed, then verify the isolation of the equipment by operating the push button or other normal operating control(s) or by testing to make certain the equipment will not operate.



CAUTION! Return operating control(s) to neutral or "off" position after verifying the isolation of the equipment.

8. The machine or equipment is now locked out.

RESTORING EQUIPMENT TO SERVICE

When the servicing or maintenance is completed and the machine or equipment is ready to return to normal operating condition, the following steps shall be taken.

1. Check the machine or equipment and the immediate area around the machine to ensure that nonessential items have been removed and that the machine or equipment components are operationally intact.
2. Check the work area to ensure that all personnel have been safely positioned or removed from the area.
3. Verify that the controls are in neutral.
4. Remove the lockout devices and re-energize the machine or equipment.

NOTE: The removal of some forms of blocking may require re-energization of the machine before safe removal.

5. Notify affected personnel that the servicing or maintenance is completed and the machine or equipment is ready for use.

PROCEDURE INVOLVING MORE THAN ONE PERSON

In the preceding steps, if more than one individual is required to lock out the sawmill, **each shall place his own personal lock on the energy isolating devices.**

SECTION 3 SETUP AND OPERATION

3.1 Setup

Use a forklift or other appropriate equipment to move the edger.



WARNING! Use extreme care and proper equipment to lift and move the edger. Lift the machine from under the front or rear of the base only, never from sides or upper carriage. Failure to do so may result in personal injury and/or machine damage.

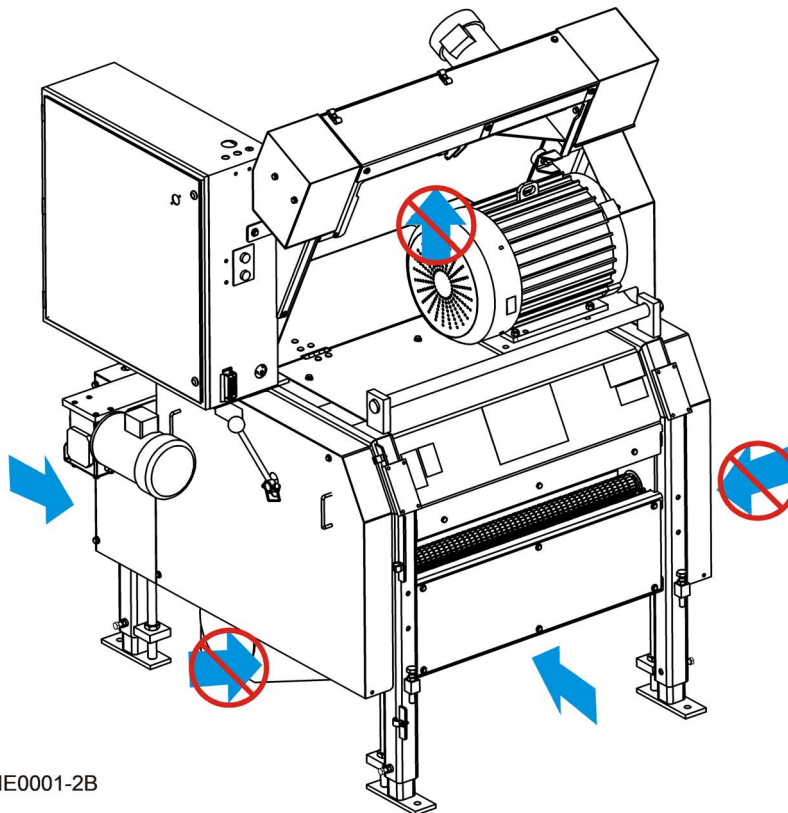

FIG. 3-1

1. Place the edger on a concrete foundation strong enough to support the weight of the machine.

NOTE: Allow for room around the edger to feed and remove boards.

2. Secure the edger to the foundation with anchor bolts.
3. Adjust the four legs of the edger so the infeed height is appropriate for your application.
4. Loosen the locking bolt and turn the adjustment nut counterclockwise to raise the edger, clockwise to lower the edger.

5. Retighten the locking bolt.

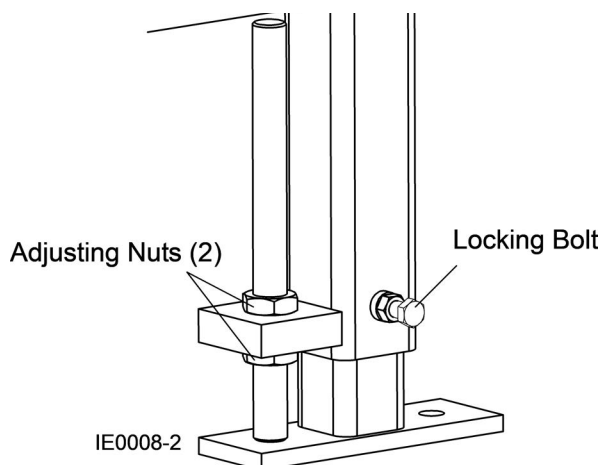

FIG. 3-2

1. Assemble the infeed table to the front of the edger with the bolts provided.
2. Use the height adjustment bolt and nut to support the infeed table properly before securing the infeed table to the edger on both sides.

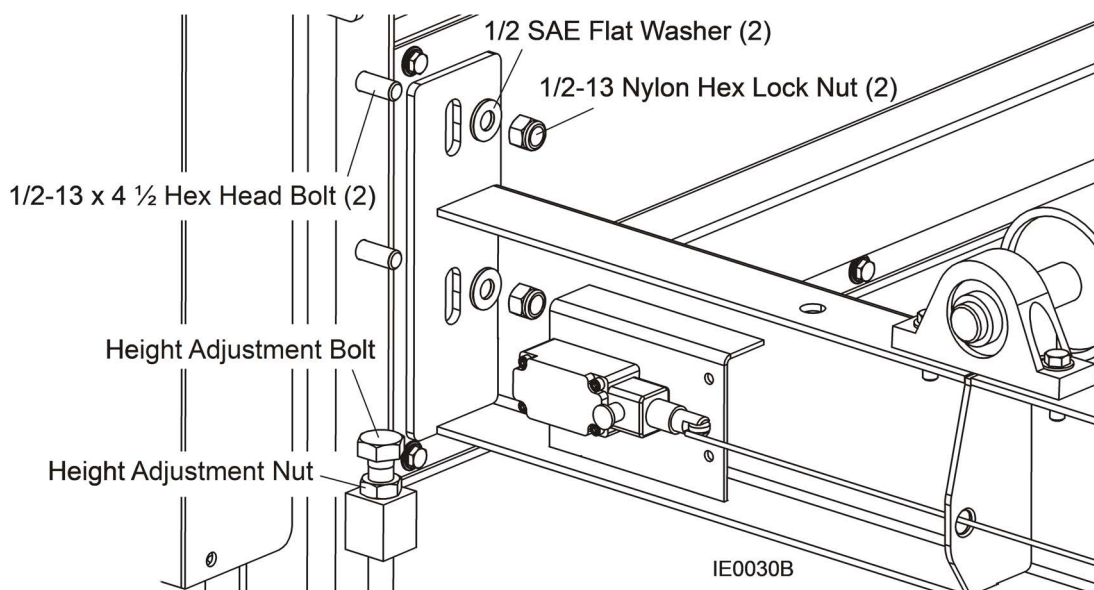

FIG. 3-3

3. Adjust the infeed table height in the same manner as the edger legs so the table is aligned with the infeed rollers of the edger.

NOTE: Make sure the infeed table rollers are leveled with the edger lower infeed drive rollers before starting cutting.

3.2 Electrical Installation

DANGER! Make sure all electrical installation, service and/or maintenance work is performed by a qualified electrician and is in accordance with applicable electrical codes.

DANGER! Hazardous voltage inside the electric disconnect box, starter box, and at the motor can cause shock, burns, or death. Disconnect and lock out power supply before servicing! Keep all electrical component covers closed and securely fastened during edger operation.

Electrical Requirements

CAUTION! The edger motors and transformer are pre-wired for 480 volt, 60 Hz power supplies. If you plan to use a 480 volt, 60 Hz edger with another type of power supply, you will need to rewire the motor to avoid damage to the machine.

The edger identification plate including the required electrical information is shown below:

MFG BY: WOOD-MIZER LLC, 8180 W. 10th St. Indianapolis, IN 46214-2400 317/271-1542 or 800/553-0182							
SERIAL #	EG400EC30	A1.00	FLA OF LARGEST LOAD	378			
FLA	42.2	IR	50kA	SCCR	5kA	VOLTS	480
	(Base unit only)					HZ	60
						PH	3
ELECTRICAL DIAGRAM #		PATENTS				S20038	

300_0003C

EG400 IDENTIFICATION PLATE

IMPORTANT! The edger is wired for use with a 480 volt power supply. To operate the edger with 240V, 400V or 600V power supplies an additional transformer is required. See the table below for transformers available from Wood-Mizer. All transformers are manufactured by Square D.

Conversion From/To	240 to 480 volts	400 to 480 volts	600 to 480 volts
Wood-Mizer Part No.	069711	068054	068185

TABLE 3-0***Installation***

Perform the following steps prior to operating the edger to make the required electrical connections:

1. Unlock and open the electrical box on the edger.
2. Locate the main disconnecter in the upper right corner inside the electrical box.
3. Route the power supply cable through the upper hole in the electrical box and above the disconnecter.
4. Connect the power supply wires to the main disconnecter in the electrical box as shown.

Connect the power supply to the main disconnect in the electrical box.

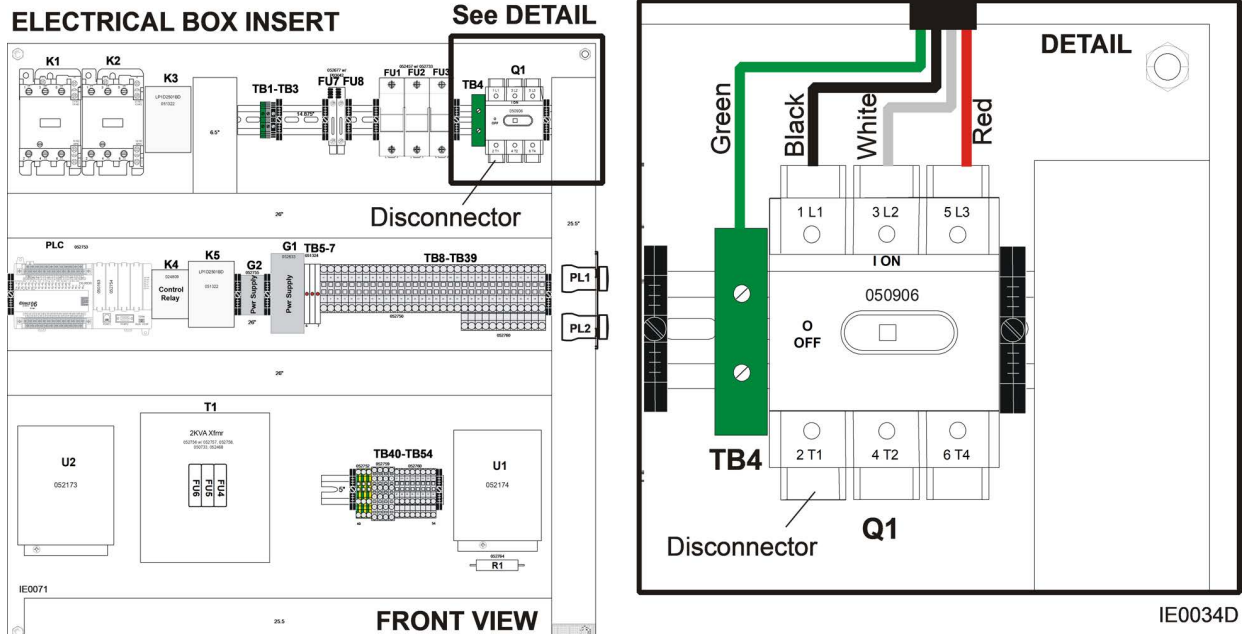

FIG. 3-4

5. Close the electrical box and lock with keys.
6. Setup the edger control box next to the edger. Make sure that the place where the control box is located is safe and comfortable to operate the edger. Connect the control box cable to the electrical box.

Connect the edger control box to the electrical box as shown.

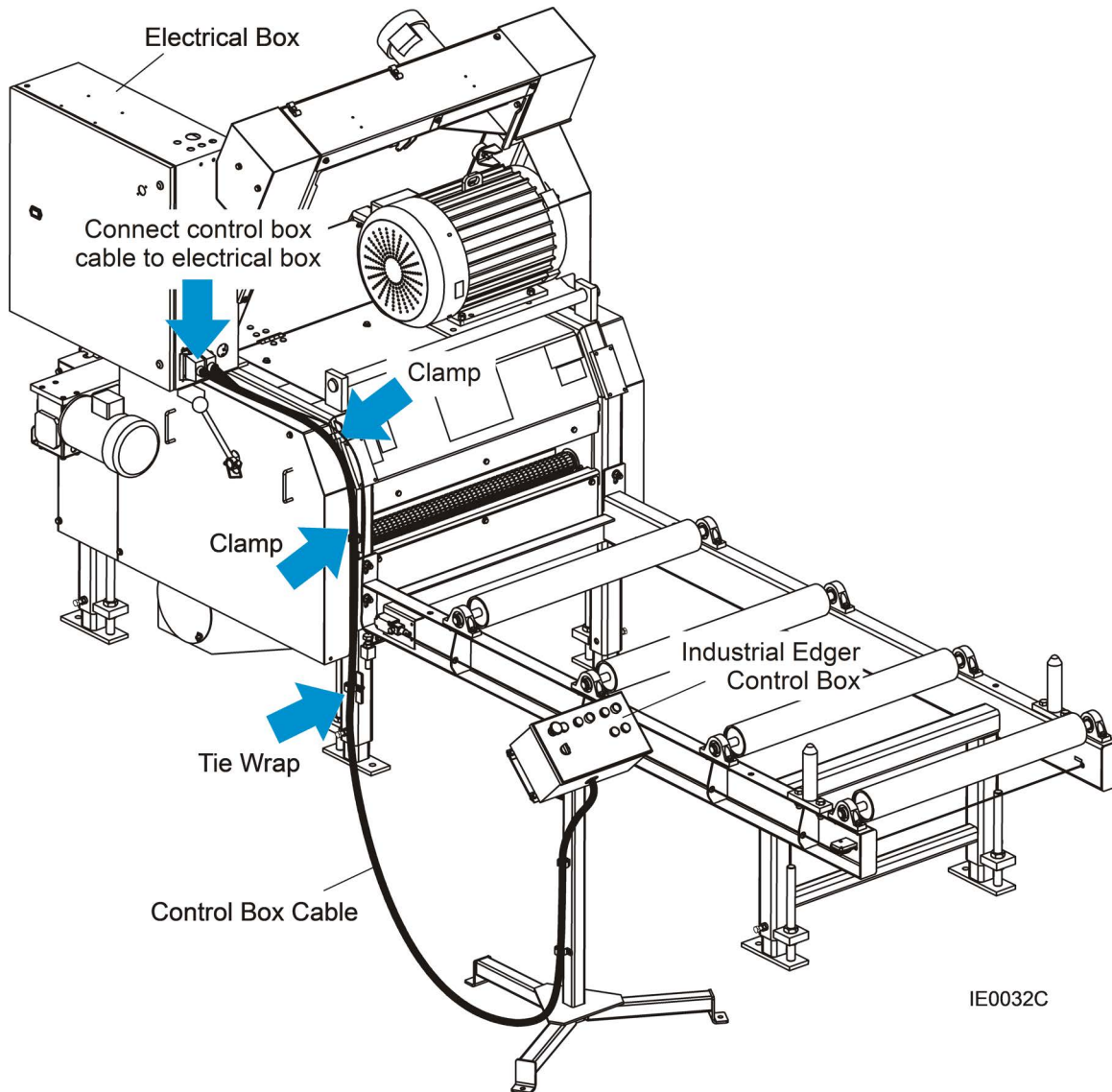

FIG. 3-5

7. Secure the control box cable with three cable clamps (3) installed to the edger frame. Make sure that the drive side removable guard can be accessed easily if necessary.

8. Connect the existing safety switch cable from the electrical box to the safety switch located on the left side of the infeed table frame. Secure the cable with the tie wraps to the control box cable.

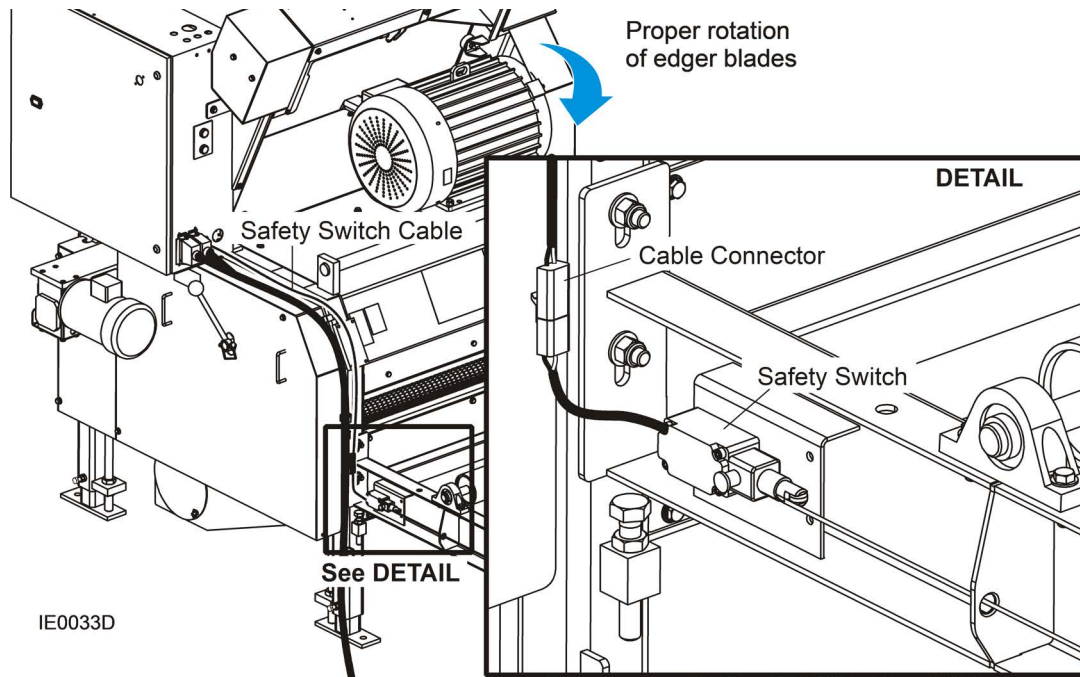

FIG. 3-6

9. Check for proper rotation of the edger blades. The infeed will always rotate the correct direction, but the blade rotation can be reversed. Push the MACHINE-START button and then the BLADES-START button. The blades should spin clockwise as viewed from the control side of the machine. If the blades spin in the wrong direction, turn off the machine, disconnect and lockout the electrical power and check the wiring. [See SECTION 6](#) for electrical wiring diagrams.



WARNING! Check for proper rotation of the blades before operating the machine. Failure to do so may result in serious injury and/or machine damage.

WARNING! Coastdown Required. Always shut off the motor and allow all moving parts to come to a complete stop before removing any guards or covers. Do NOT operate with any guards or covers removed.

WARNING! Always shut off the motor to stop the blade whenever the edger is not in use. Failure to do so may result in serious injury.

3.3 Pre-Operation Check

Prior to operating the Edger; always perform these basic checks:

1. Make sure the Edger has been properly set up.
2. Make sure the motor drive belt is tensioned properly. [See Section 4.3](#) for more information.



WARNING! Do not for any reason adjust the motor drive belts with the motor running. Doing so may result in serious injury.

3. Be sure the anti-kickback fingers are in proper working condition.



WARNING! Always ensure that there is a sharp point on the anti-kickback fingers before each use of the Edger.

Be sure anti-kickback fingers are free from obstruction and are in a downward position with lever released. Failure to do so may result in serious injury.

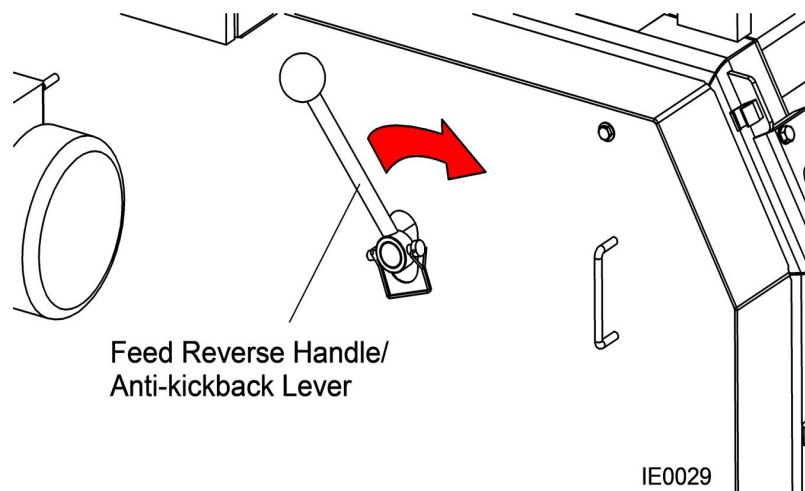

FIG. 3-7

NOTE: The feed reverse handle/anti-kickback lever lifts the anti-kickback finger, shuts down the blades and reverses the infeed movement. Release the lever and restart the blades by pressing the START BLADES button on the control box to continue cutting.

4. Be sure all guards and covers are in place and secured.



DANGER! Make sure all guards and covers are in place and secured before operating the Edger. Failure to do so may result in serious injury.

5. Also be aware that the blades are spinning whenever the motor is ON. You should always turn off the motor to stop the blade whenever the Edger is not in use and ensure that all parts have stopped moving before removing any covers or guards.



WARNING! Coastdown Required. Always shut off the motor and allow all moving parts to come to a complete stop before removing any guards or covers. Do NOT operate with any guards or covers removed.

WARNING! Always shut off the motor to stop the blade whenever the Edger is not in use. Failure to do so may result in serious injury.

6. An Emergency Stop is located on the front panel of the Edger control box. Press the Emergency Stop to shut down the edger. Before operating the Edger again, turn the E-Stop switch clockwise and release.

The Edger is also equipped with an additional Emergency Stop switch located on the infeed table. The switch is activated by pulling the red cable installed around the infeed table frame. Pull the cable to shut down the edger. Restart the Edger using the buttons and switches on the control box when necessary.



WARNING! Always check the control box mounted and cable activated Emergency Stop switches for proper operation prior to each use of the machine. Failure to do so may result in serious injury.

WARNING! Always disconnect and lockout power before performing any service to the edger. Follow the lockout procedure provided in the safety section ([See Section 2.2](#)). Failure to do so may result in serious injury.

3.4 Starting & Stopping The Machine

DANGER! Make sure all guards and covers are in place and secured before operating the edger. Failure to do so may result in serious injury. Be sure the blade housing and pulley covers are in place and secure.

Always be sure all persons are away from the edger before starting the motor. Failure to do so will result in serious injury.

WARNING! Always wear eye, ear, respiration, and foot protection when operating the edger. Failure to do so may result in serious injury.

Always check the control box mounted and cable activated Emergency Stop switches for proper operation prior to each use of the machine. Failure to do so may result in serious injury.

1. If necessary, release the MACHINE E-STOP button by turning it clockwise until it pops out.

The main control panel has switches to start and stop edger functions.

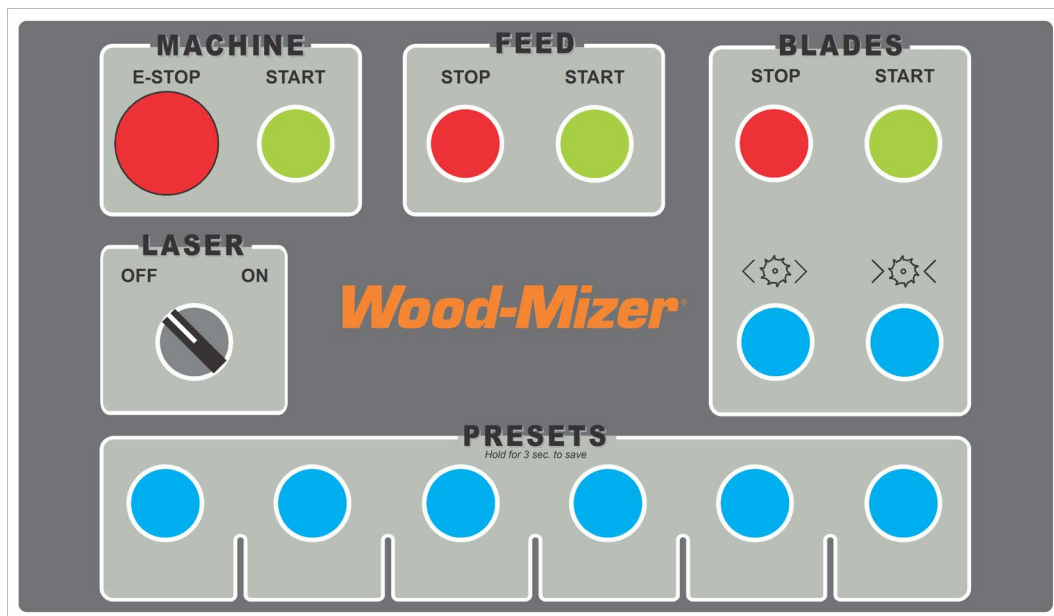

IE0003D

FIG. 3-0

2. Push the green MACHINE-START button on the control box to turn on the edger power.

NOTE: The covers and the electrical cabinet must be closed before the edger can be started.

3. Turn the laser guides on by turning the LASER switch to the ON position.
4. Adjust the position of the blade by pushing the left or right blue POSITION buttons on the control box until the lasers indicate the desired position.

NOTE: If there is material still in the feed path or the feed rollers are not in the rest position, the MACHINE START light on the control panel and MACHINE ON light on the electrical cabinet will flash. Changes in blade position cannot be made while the lights are flashing.

NOTE: If the edger is equipped with the optional Networks, you can use the preset buttons to move the blades to the desired position. [See Section 3.6](#) for details.

5. Push the BLADES-START button to start the edger blades.
6. Push the FEED-START button to start the edger feed system. **NOTE:** The edger feed system will not start unless the blades have been started first.

SHUTDOWN SWITCHES

1. Push the MACHINE-E-STOP button in an emergency to stop and shut down the edger. This button must be released by turning clockwise before the edger can be restarted.

Pull out the emergency red wire around the infeed table whenever it is necessary to shut down the edger.

2. Push the FEED-STOP or BLADE-STOP buttons to stop the corresponding functions without shutting down the machine.
3. Turn the LASERS switch to OFF to turn off the laser guides.

3.5 Edging Lumber



DANGER! Make sure all guards and covers are in place and secured before operating the Edger. Failure to do so may result in serious injury.

Keep all persons out of the path of moving equipment and boards when operating the Edger or loading boards. Failure to do so will result in serious injury.

Moving Parts Can Crush and Cut. Keep hands clear. Make sure all guards and covers are in place and secured before operating. Failure to do so may result in serious injury.

Maintain a clean and clear path for all necessary movement around the Edger and lumber stacking areas. Failure to do so will result in serious injury.



WARNING! Always shut off the machine to stop the blade whenever the Edger is not in use. Failure to do so may result in serious injury.

Always wear eye, ear, respiration, and foot protection when operating the Edger. Failure to do so may result in serious injury.

Secure all loose clothing and jewelry before operating the Edger. Failure to do so may result in serious injury or death.

1. Start the machine and turn the lasers on as described in Section 3.4 Starting & Stopping The Machine.
2. Place the board in the approximate center of the infeed table. Use the provided pivot posts to assist loading if necessary.

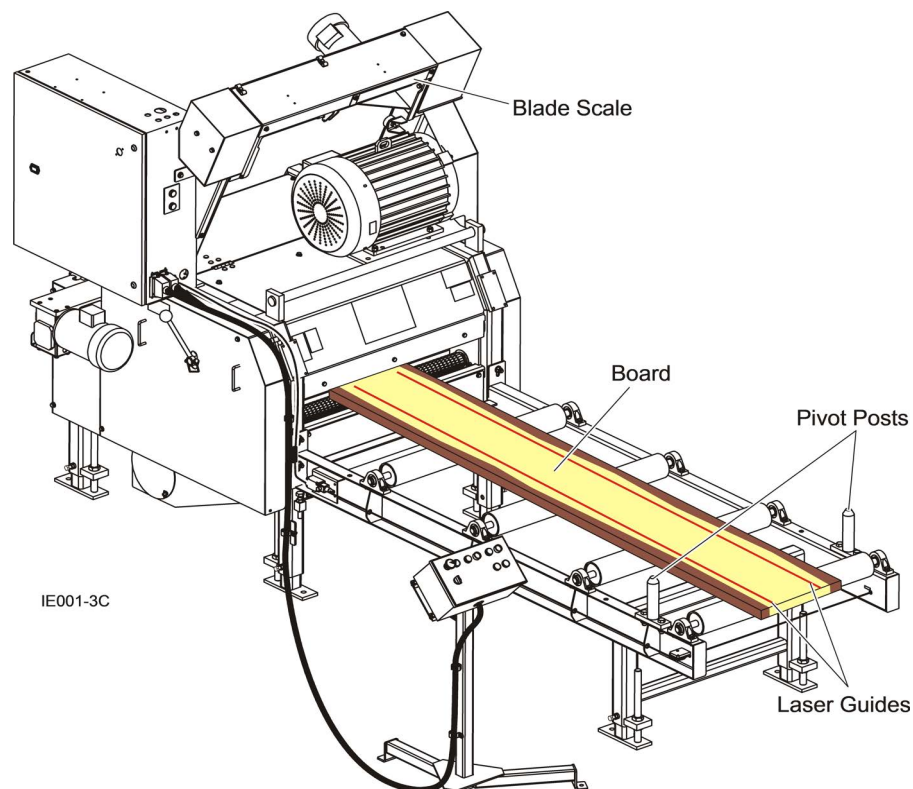

FIG. 3-8

3. Use the blade adjustment button on the control panel to move the blades as desired. The laser lights will show the path of the blade. Use the top scale located on the laser guide housing to determine the width of cut.

NOTE: If the edger is equipped with the optional LED display, use the display unit to determine the width of cut.

NOTE: If the edger is equipped with the optional Networks, you can use the preset buttons to move the blades to the desired width. Use the optional LED display to check the current width of cut. [See Section 3.6](#) for details.

4. Start the blade motors and the feed motor. Push the board into the edger until the feed system takes the board.
5. Repeat the above procedures for all boards to be edged.
6. Shut down the machine when done edging.

3.6 Networks Setup & Operation (Optional)



DANGER! Make sure all guards and covers are in place and secured before operating the edger. Failure to do so may result in serious injury. Be sure the blade housing and pulley covers are in place and secure.

DANGER! Always be sure all persons are away from the edger before starting the motor. Failure to do so will result in serious injury.



WARNING! Always wear eye, ear, respiration, and foot protection when operating the edger. Failure to do so may result in serious injury.

WARNING! Always check the control box mounted and cable activated Emergency Stop switches for proper operation prior to each use of the machine. Failure to do so may result in serious injury.

Setworks Calibration

The Setworks may need to be calibrated before operating the edger.

1. Push the MACHINE START button on the control box to turn the edger power on.

NOTE: The covers and the electrical cabinet must be closed before starting the edger.

2. Use the BLADES IN or BLADES OUT buttons to move the blades until they are exactly 10" (254mm) apart.
3. Press and hold the FEED START and FEED STOP buttons simultaneously until the display shows "10" (or "254mm").

The Setworks is now calibrated and ready to operate.

Setworks Enable/Disable

1. Turn the edger power on.
2. Enable Setworks in imperial units, by pressing and holding the PRESET #1 & the FEED STOP buttons simultaneously for 10 seconds until the display reads "Imperial Setworks Enabled".
3. Enable Setworks in metric units, by pressing and holding the PRESET #2 & the FEED STOP buttons simultaneously for 10 seconds until the display reads "Metric Setworks Enabled".
4. Disable Setworks, by pressing and holding the PRESET #3 & the FEED STOP buttons simultaneously for 10 seconds until the display reads "Setworks Disabled".

Setworks Operation

1. Push the MACHINE START button on the control box to turn the edger power on, if necessary.
2. Enable the Setworks as described above, if necessary.
3. Turn the laser guides on by turning the LASER switch to the ON position.
4. Press one of the six Setworks switches on the control box to adjust the position of the blades. Pressing the preset button will move the blades to the position already programmed into the button. Use the optional LED display to check the current width of cut.
5. Push the BLADES START button to start the edger blades.

6. Push the FEED START button to start the edger feed system.

Networks Programming

The Networks default values are programmed in the factory but can be easily reprogrammed by the edger operator.

The default values of the preset buttons are shown below.

Networks Button #	Imperial	Metric
Preset 1	8"	203mm
Preset 2	10"	254mm
Preset 3	12"	305mm
Preset 4	14"	356mm
Preset 5	16"	406mm
Preset 6	18"	457mm

TABLE 3-1

To reprogram the Networks preset buttons:

1. Use the BLADES IN or BLADES OUT buttons to move the blades to the desired position.
2. Press and hold one of the Networks buttons for 3 seconds. While the new value is being stored the preset light indicator will be off. When the value is stored the light indicator will turn on.
3. Repeat steps 1-2 for the remaining preset buttons.

3.7 Remote Operation (Optional)

The 6-button remote transmitter is used to change the width of cut on the edger as necessary. To move the blades to the desired position, press one of the buttons on the remote transmitter. **NOTE:** If the Edger is not equipped with the optional Networks, buttons #5 and #6 are the only functioning buttons on the remote transmitter. Press the button #5 to move the blades in; press the button #6 to move the blades out.

The 6-button remote transmitter is shown below.



FIG. 3-9

NOTE: If the Edger is equipped with the optional Networks, the remote buttons 1-4 have the same preset values programmed as the values stored in the Networks preset buttons 1-4 on the operator control box.

The default values of the remote transmitter buttons when the Edger is equipped with the optional Networks are shown below.

Remote Button #	Imperial	Metric
Preset 1	8"	203mm
Preset 2	10"	254mm
Preset 3	12"	305mm
Preset 4	14"	356mm
Preset 5	Press to Move Blades In	
Preset 6	Press to Move Blades Out	

TABLE 3-2

The operator can easily change the factory-programmed preset values by using the optional Networks preset buttons on the control box. To reprogram the Networks preset buttons:

1. Use the BLADE-IN or BLADE-OUT buttons to move the blades to the desired position.
2. Press and hold one of the Networks buttons for 3 seconds. While the new value is being stored the preset light indicator will be off. When the value is stored the light indicator will turn on.
3. Repeat steps 1-2 for the remaining preset buttons.

SECTION 4 MAINTENANCE

Refer to the motor manufacturer's manual for maintenance intervals and procedures regarding the power supply unless otherwise instructed in this manual. Follow the manufacturer's recommendations for dusty conditions.

NOTICE This manual only provides information about additional procedures or procedures to be performed at different time intervals than found in the manufacturer's manuals. Refer to the manufacturer's manual for complete maintenance instructions.

4.1 Replacing the Blade Teeth



DANGER! Coastdown Required. Always shut down the edger and allow all moving parts to come to a complete stop before removing any guards or covers. Do NOT operate with any guards or covers removed.



WARNING! Always disconnect and lockout power before performing any service to the edger. Follow the lockout procedure provided in the safety section ([See Section 2.2](#)). Failure to do so may result in serious injury.

Replace the blade teeth as necessary. Dull blade teeth will cause the motor to work harder and will result in decreased cut quality and accuracy. Blade teeth life will vary depending on maintenance of machine, operator, species of wood being sawn, and condition of wood being sawn. To remove the blade teeth perform the following steps:

1. Unbolt and open the rear top blade guard. Make sure the guard is secured properly during the blade tooth replacement procedure.
2. Lift the upper idle roller with a rod. To do so, insert the rod into the slot on the right side of the upper idle roller. Make sure the roller rests safely before starting the blade tooth replacement procedure.

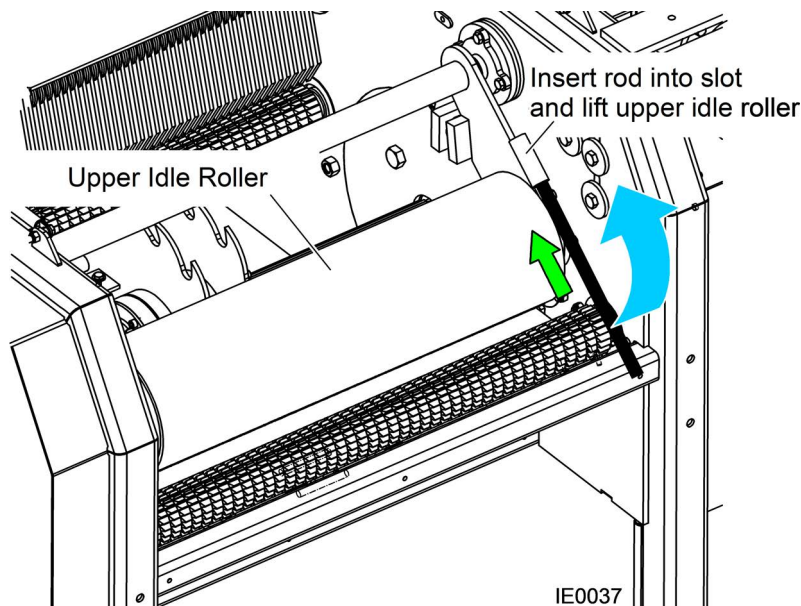

FIG. 4-1

3. Place the blade tooth replacement tool on the blade tooth to be removed.

- Secure the replacement tool with the locking pin, so that the longer end of the locking pin comes both through the lower hole in the replacement tool and the hole in the blade tooth.

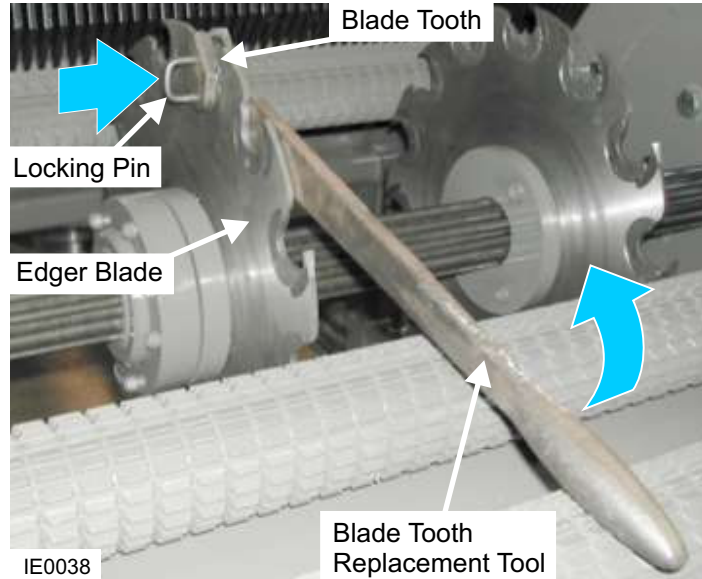

FIG. 4-2

- Remove the blade tooth by moving the replacement tool handle upwards.

REPLACE THE BLADE TOOTH

- Install the new blade tooth in the blade tooth replacement tool. Secure the blade tooth to the replacement tool with the locking pin.
- Place the replacement tool on the blade where the blade tooth is to be installed.
- Move the replacement tool downwards to install the new blade tooth in place.
- Remove the locking pin from the replacement tool when done. Remove the replacement tool from the blade.
- Repeat the procedure with the remaining blade teeth.
- Use the rod to lower the idle roller when done.
- Close the rear top blade guard.
- Secure the guard with the existing bolts.

4.2 Changing the Blades

1. Replace the blades as necessary. **NOTE:** It may be necessary to replace the blades only due to their damage. The blades are equipped with replaceable cutting teeth. [See Section 4.1](#) to replace the blade teeth.

 **DANGER!** Before changing the blades, make sure the blades have come to a complete stop and the edger is shut down completely. Failing to do so can cause serious injury.

 **WARNING!** Always disconnect and lockout power before performing any service to the edger. Follow the lockout procedure provided in the safety section ([See Section 2.2](#)). Failure to do so may result in serious injury.

Always wear eye, glove and foot protection when handling saw blades.

2. Unbolt and open the rear top blade guard.
3. Use a supporting strap to keep the shaft in place before removing the blade door assembly on the left side of the edger.

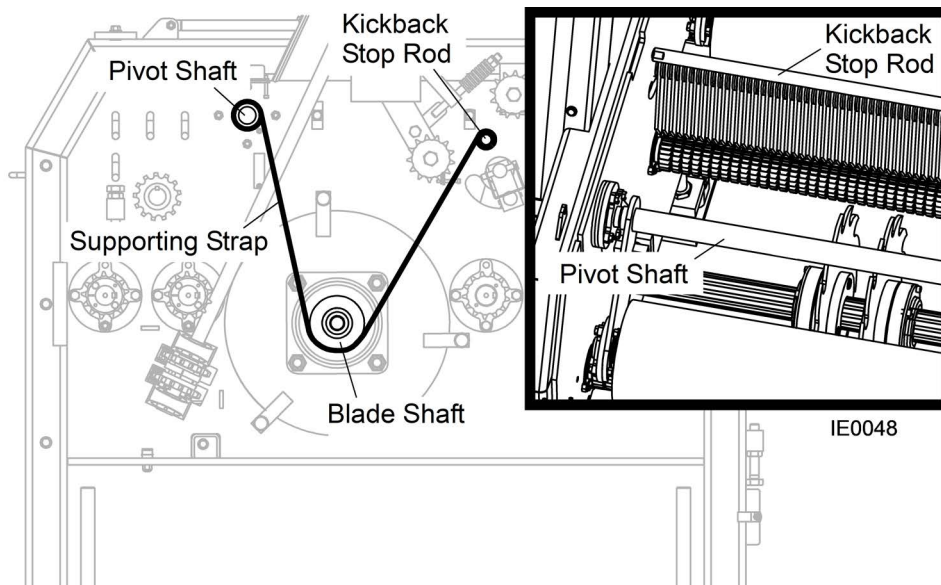
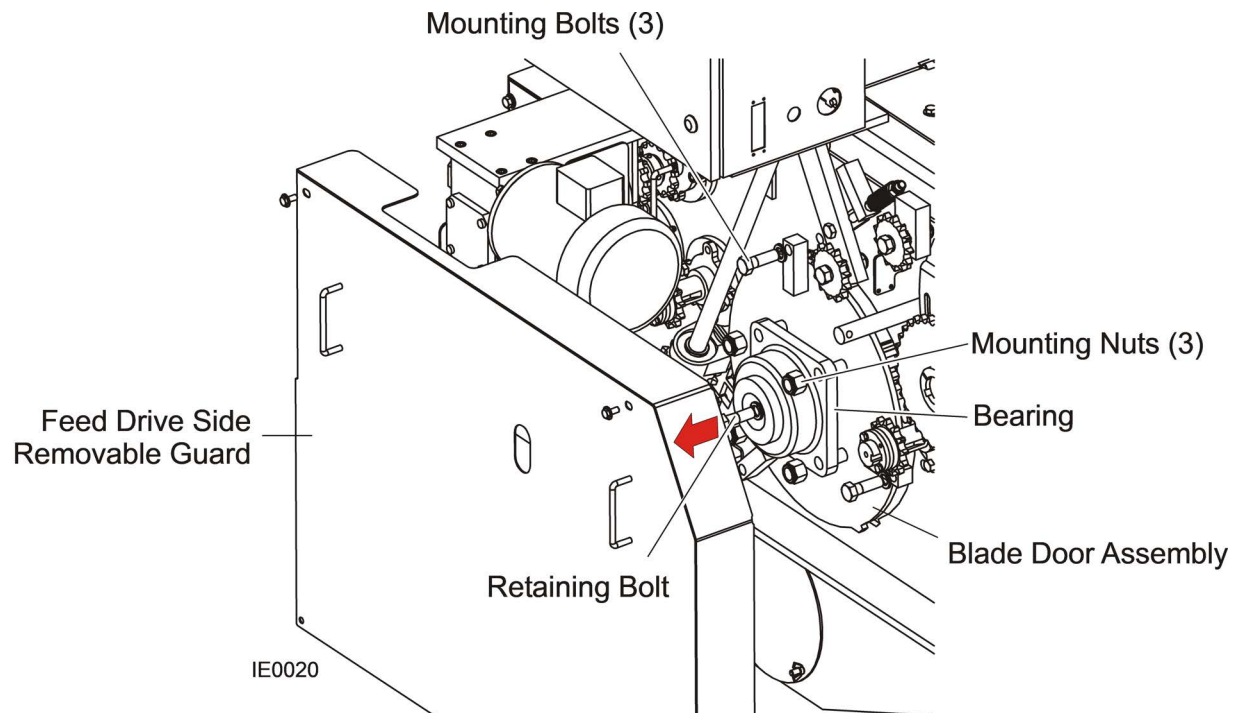

FIG. 4-3

4. Remove the locking nuts securing the right and left blade pushers to the blades. Uninstall the blade pushers from the blades.
5. Remove the feed drive side removable guard from the Edger.
6. Remove the blade door assembly from the Edger.
 - Unbolt the blade door assembly.
 - Loosen the retaining bolt and remove the four mounting nuts on the bearing.
 - Pry the blade door assembly from the Edger and remove the door.

**FIG. 4-4**

7. Remove the blades from the shaft. Make sure the right and left blade pushers are already uninstalled from the blades and lowered properly.
8. Slide the blades out through the blade door hole.

NOTE: It can be necessary to raise the shaft 2-3 inches to allow the blades to pass the blade pushers.

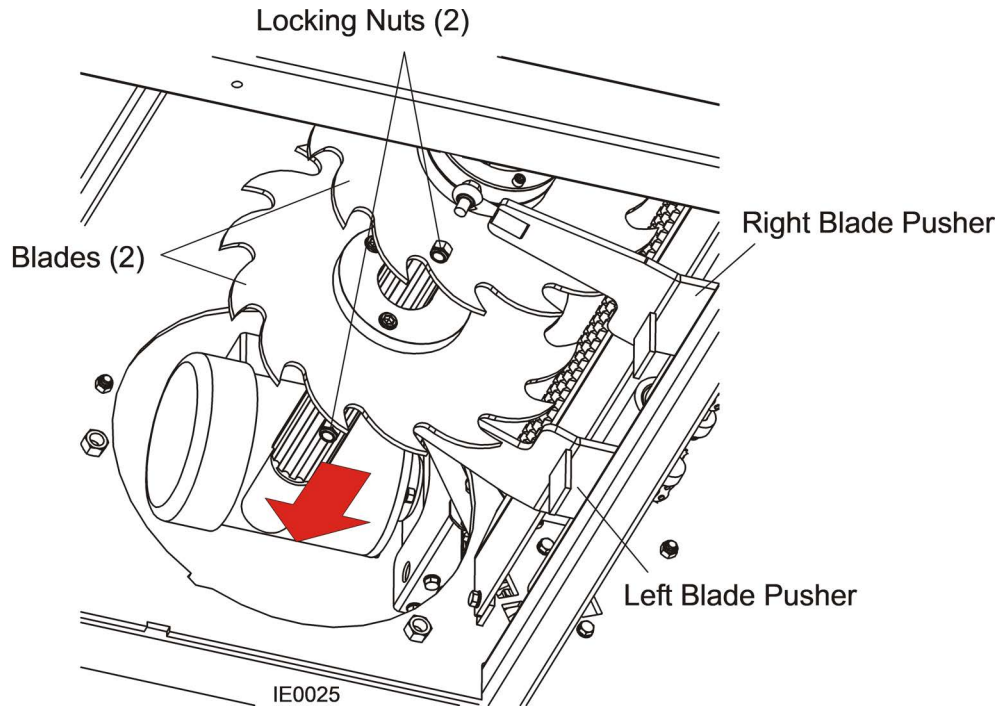

FIG. 4-5

9. Place the new blades on the shaft and position them next to the right and left blade pushers.
10. Install the right and left blade pushers to the blades.
11. Reinstall the blade locking nuts to secure the pushers to the blades.
12. Reinstall the blade door assembly and secure in place with the mounting bolts.
13. Reinstall the blade bearing and retaining bolt. Secure the bearing in place with the existing mounting nuts.
14. Remove the supporting strap from the blade assembly.
15. Close and secure the rear top blade guard.

4.3 Tensioning the Belts



DANGER! Coastdown Required. Always shut down the edger and allow all moving parts to come to a complete stop before removing any guards or covers. Do NOT operate with any guards or covers removed.



WARNING! Always disconnect and lockout power before performing any service to the edger. Follow the lockout procedure provided in the safety section ([See Section 2.2](#)). Failure to do so may result in serious injury.

Do not for any reason adjust the motor drive belts with the motor running. Doing so may result in serious injury.



CAUTION! Never apply belt dressing as this will damage the belt and cause early failure.

1. Check the drive belt for wear **every 8 hours** of operation and more frequently during the first 24-48 hours of operation.
2. Tension or replace as necessary.

NOTE: Tension should be 1/2" deflection with 16 lbs of force for new belts or 1/2" deflection with 11 lbs of force for used belts.

To tension the drive belt:

- Unbolt and open the blade drive side removable guard.
- Loosen the motor mounting nut securing the adjustment bolt.
- Use the adjustment bolt as shown below to move the motor mount up or down until the belt is properly tensioned.

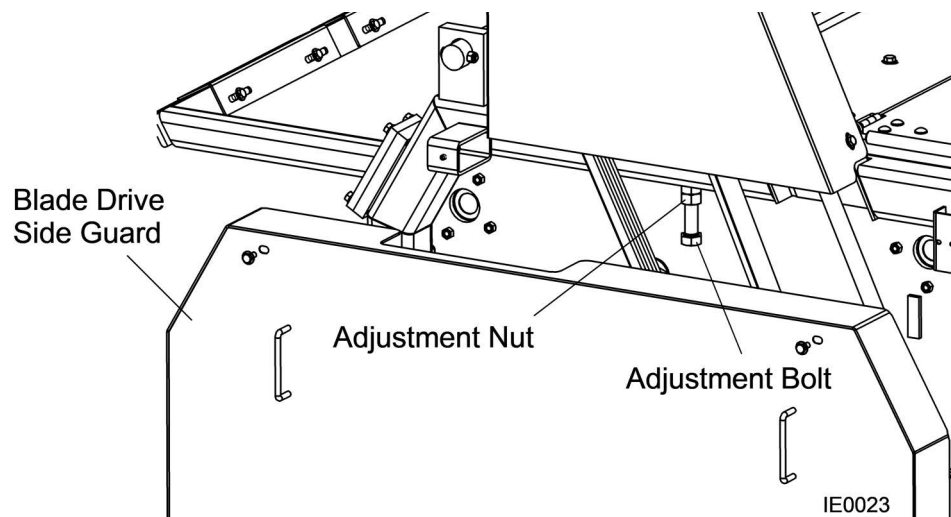

FIG. 4-6



CAUTION! Do not over tighten the drive belt as it can cause premature belt and/or bearing failure.

CAUTION! Do not under-tighten the drive belt as it can cause one or all of the following damages: slippage of the belt on the drive pulley, binding or fetching up of the saws while in the cut, damage or bending of saws

- Retighten the motor mounting nut when done.
- Close and secure the blade drive side removable guard.

3. Check the laser light box timing belt for wear every 8 hours of operation. Tension or replace as necessary. The belt tensioner should be adjusted closely enough to remove any belt slack. Do not overtighten.

To tension the laser light box belt:

- Locate the adjustment pulley in the laser light box. Loosen the mounting nut securing the adjustment pulley.
- Push the adjustment pulley up or down until the belt is tensioned as needed.

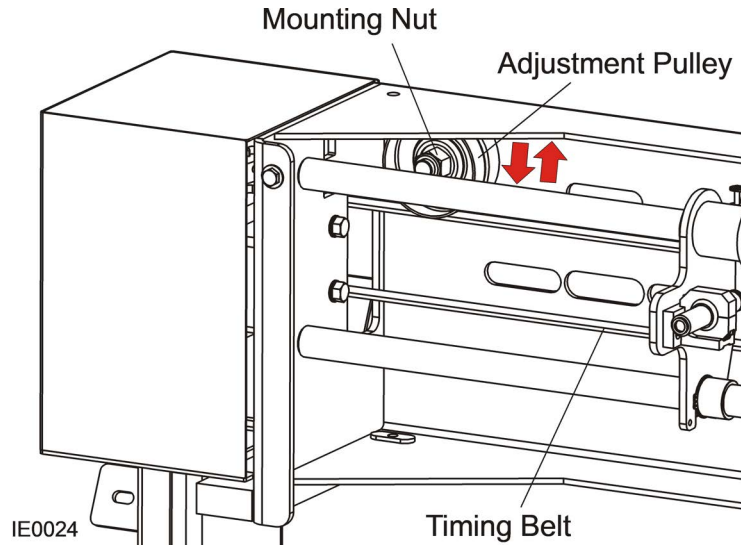

FIG. 4-7

- Retighten the adjustment nut to secure the adjustment pulley when done.

4.4 Tensioning the Chains

DANGER! Coastdown Required. Always shut down the edger and allow all moving parts to come to a complete stop before removing any guards or covers. Do NOT operate with any guards or covers removed.

WARNING! Always disconnect and lockout power before performing any service to the edger. Follow the lockout procedure provided in the safety section ([See Section 2.2](#)). Failure to do so may result in serious injury.

IMPORTANT: It is necessary to tension the outfeed drive chain first before tensioning the infeed drive chain.

Refer to the following diagram for chain routing instructions.

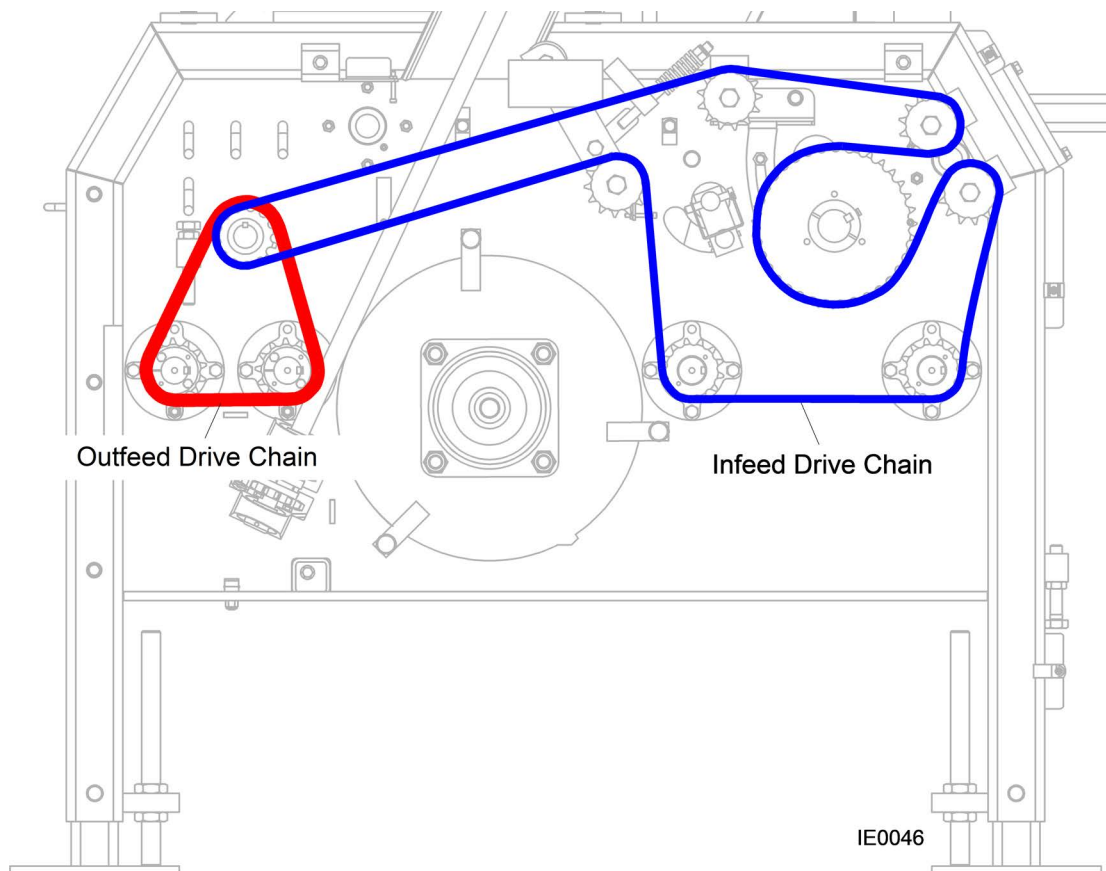
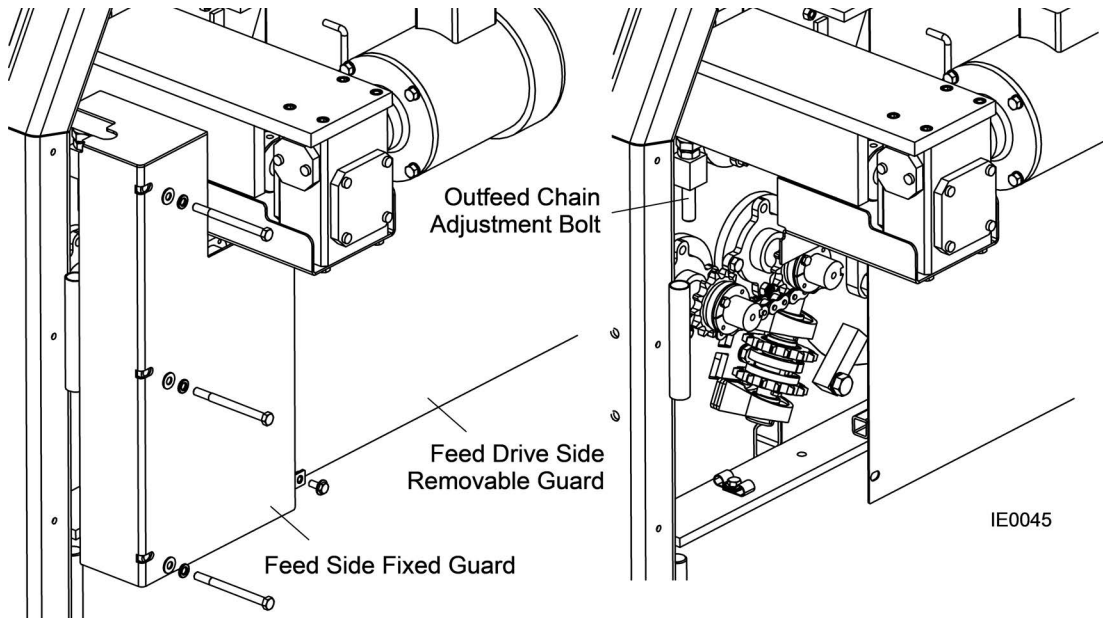

FIG. 4-8

TENSION THE OUTFEED DRIVE CHAIN

1. Unbolt and open the feed side fixed guard.

**FIG. 4-9**

2. Loosen the four bolts securing the edger feed drive assembly to the edger frame.
3. Rotate the adjustment bolt below the edger feed drive assembly clockwise/counterclockwise until the outfeed drive chain is tensioned as needed. The outfeed chain total deflection should not exceed 1/4" in the center of the chain between the sprockets.
4. Tighten the four bolts mounting the edger feed drive assembly to the edger frame.
5. Close and secure the feed side fixed guard.

TENSION THE INFEEED DRIVE CHAIN

1. Unbolt and open the feed drive side removable guard.
2. Turn the adjustment nut on the drive chain tensioner until the drive chain is tensioned as needed.

NOTE: The total deflection of the spring should be from 3/8" to 1/2".

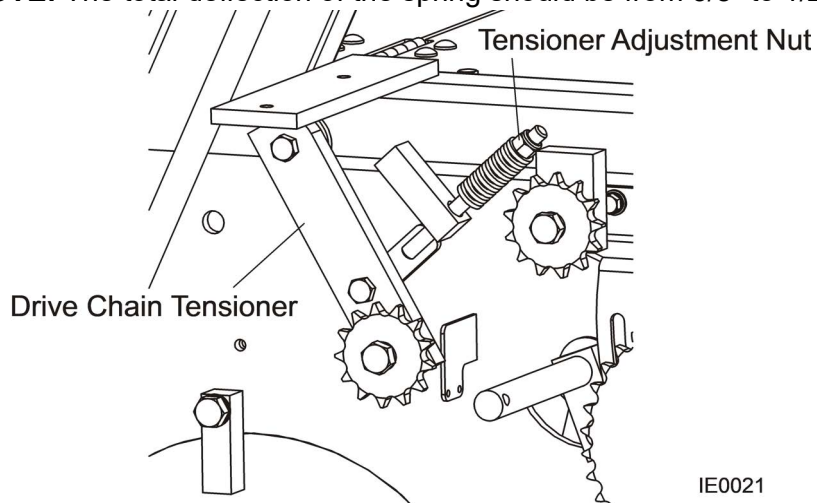
**FIG. 4-10**

3. Close and secure the feed drive side removable guard when done.

CHECK THE LASER DRIVE CHAINS

1. Check tension **every 40 hours** of operation and adjust tension as necessary.
2. Remove the chain slack but do not overtighten.

NOTE: The properly adjusted chain should have 1/4" to 3/8" vertical deflection when applying 6 to 8 pounds of force.

3. Turn the two adjustment nuts at the rear of each laser assembly until the chain is tensioned as needed.

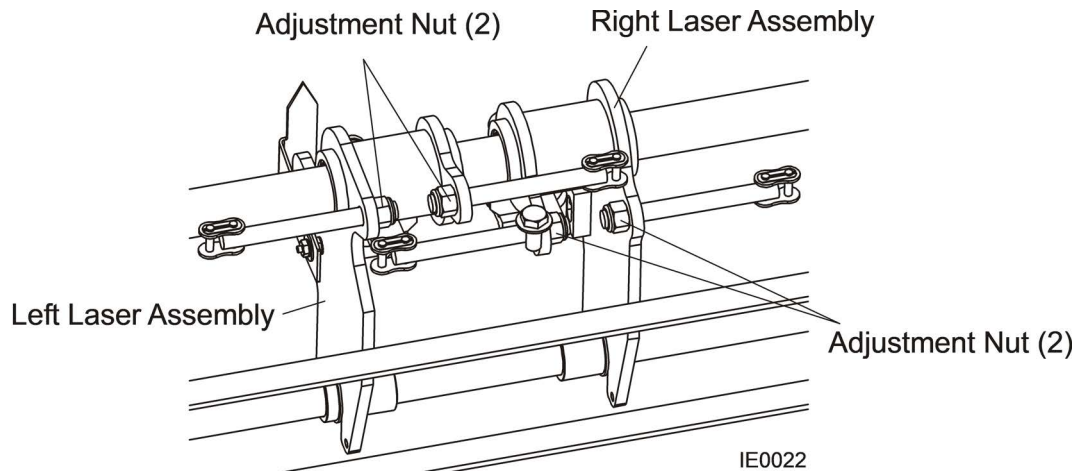

FIG. 4-11

4.5 Feed Rate

The feed rate can be readjusted. There are three possible feed rates depending on the board thickness. The factory setting is shown below.

Board Thickness	Average Feed Rate (ft./min.)
Up to 1.5"	111
1.5"-4"	78
4"	44

TABLE 4-0

The feed rate can be readjusted by changing the position of two proximity switches located under the feed drive side removable guard.



DANGER! Coastdown Required. Always shut down the edger and allow all moving parts to come to a complete stop before removing any guards or covers. Do NOT operate with any guards or covers removed.



WARNING! Always disconnect and lockout power before performing any service to the edger. Follow the lockout procedure provided in the safety section ([See Section 2.2](#)). Failure to do so may result in serious injury.

CHANGE THE POSITION OF THE PROXIMITY SWITCH

1. Remove the anti-kickback lever and feed drive side removable guard from the Edger.
2. Loosen the nuts securing the proximity switches to the mount bracket.

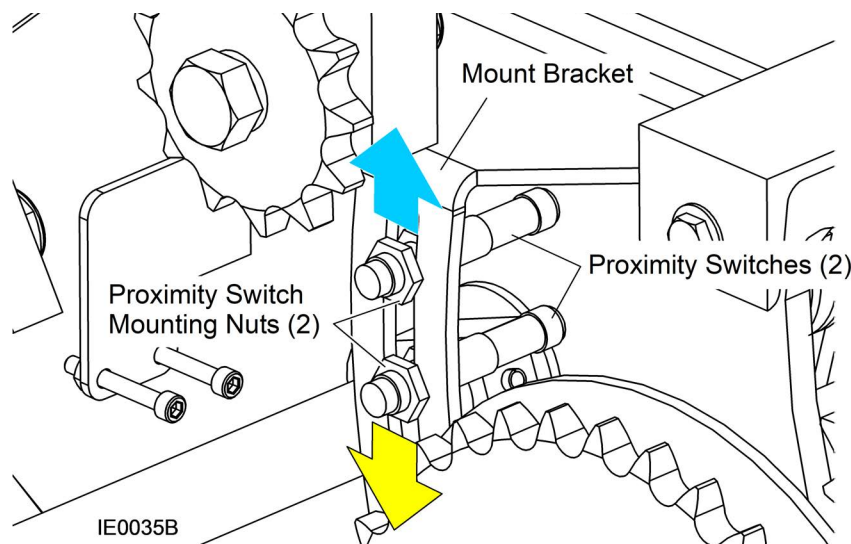

FIG. 4-12

3. Move the proximity switches to a desired position.
4. Tighten the nuts on the proximity switches and secure in place.
5. Reinstall the feed drive side removable guard and anti-kickback lever to the Edger.

4.6 Maintaining and Sharpening Anti-Kickback Fingers



DANGER! This machine has the potential for kick-backs. Kick-backs can cause the board to be suddenly and uncontrollably hurled towards the operator. Such action will result in severe injury or death.

If working with frozen boards or with boards that have protruding knots, the chance of kickbacks is increased.

The infeed opening of the Industrial Edger is equipped with anti-kickback fingers to help prevent kickback from occurring. To maintain the safety of your Edger, periodically inspect the machine to ensure all anti-kickback fingers are intact and undamaged and have a sharp point. Missing or damaged parts can affect the safety of the machine operator or bystanders and should be replaced immediately. Dulled parts should be re-ground with a hand grinder or replaced.



DANGER! Always ensure that there is a sharp point on the anti-kickback fingers before each use of the Edger.

Be sure anti-kickback fingers are free from obstruction and are in a downward position with lever released. Failure to do so may result in serious injury.

4.7 Laser Guides Alignment



WARNING! Coastdown Required. Always shut off the motor and allow all moving parts to come to a complete stop before removing any guards or covers. Do NOT operate with any guards or covers.

Always disconnect and lockout power before performing any service to the edger. Follow the lockout procedure provided in the safety section ([See Section 2.2](#)). Failure to do so may result in serious injury.

1. Open the blade housing cover to access the edger blades.
2. Run a straight edge from the front of the Edger frame to the back.
3. Put the straight edge next to the blade and make sure it is parallel to the blade.

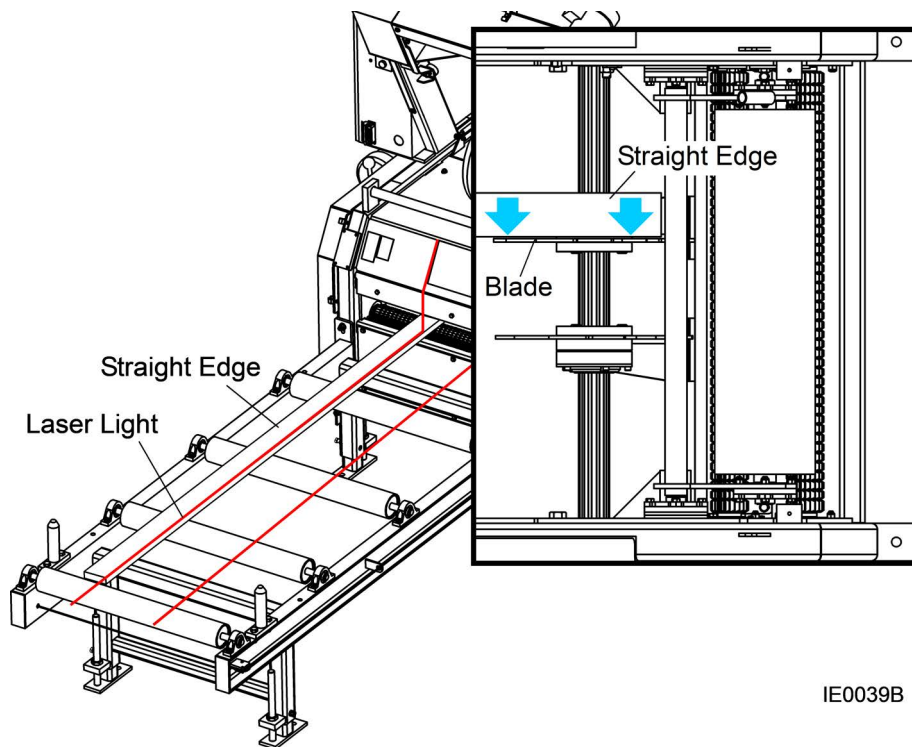

FIG 4-12

4. Turn on the edger and check the position of the laser lights on the straight edge.
5. Adjust the laser guides if necessary.

LASER ADJUSTMENT PROCEDURES.

1. To move the laser light up or down, loosen the nut on the slotted screw securing the laser to the guide assembly.
2. Move the rear part of the laser guide assembly up or down to put the laser light closer or further away from the edger main frame.

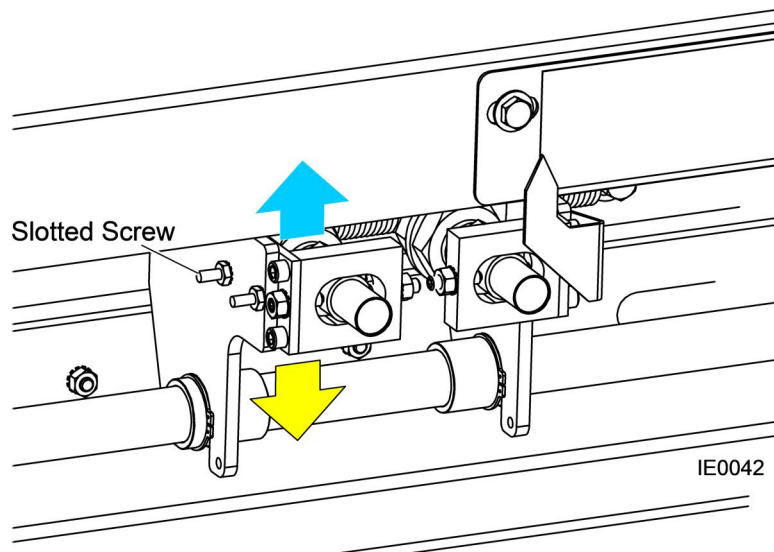
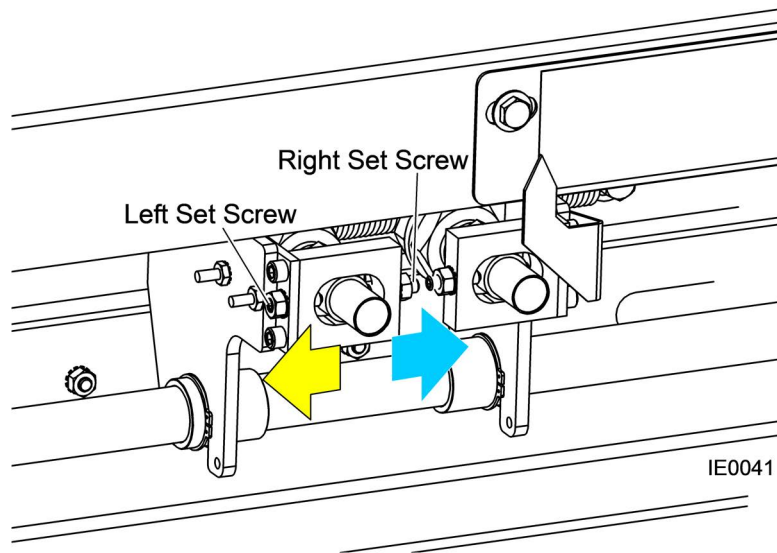

FIG 4-12

3. Make sure the laser light lays down on all four infeed table rollers.
4. Tighten the nut on the slotted screw when finished.

5. To move the laser light right or left, loosen two set screws located on both sides of the laser guide.
 - Tighten the left set screw to move the laser guide to the left side.
 - Tighten the right set screw to move the laser guide to the right side.

**FIG 4-12**

6. Check if the laser light is parallel to the straight edge.
7. Secure both set screws in place when finished.

8. To move the laser light when slanted, use the laser guide adjustment nut on the laser guide assembly.
9. Turn the adjustment nut clockwise to move the laser light as shown below and check the laser light position.
10. Turn the adjustment nut counterclockwise to move the laser light to the opposite directions as shown below and check the laser light position. The laser light must be parallel to the straight edge.

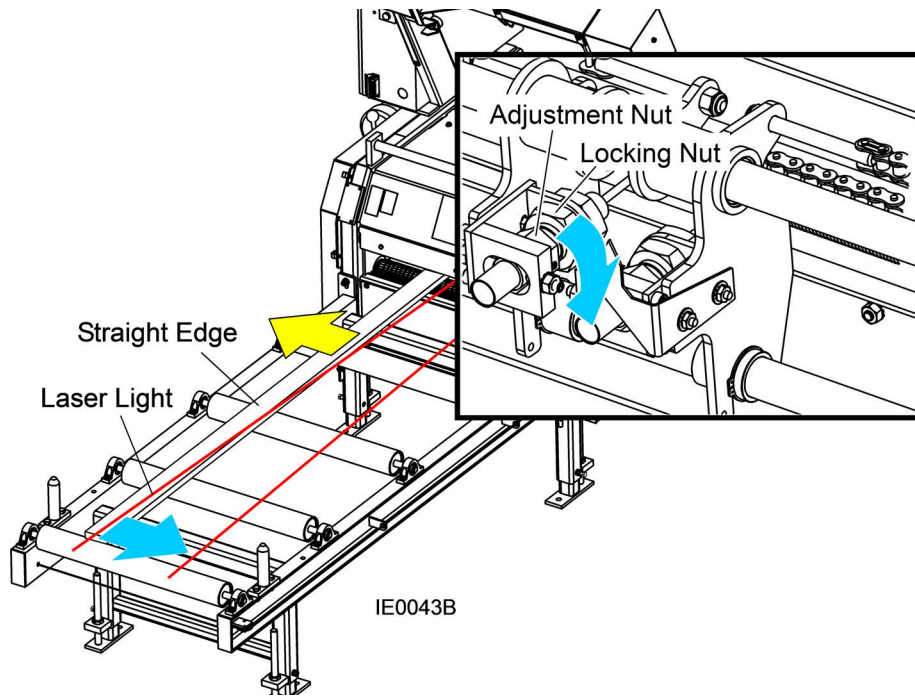

FIG 4-12

11. Repeat the steps above to align the other laser guide assembly if necessary.

4.8 Maintenance Log

MAINTENANCE LOG		DAILY MAINTENANCE PROCEDURES										
Inspect/replace blade teeth or blade	See Section 4.1 See Section 4.2	Daily										
Check drive/laser timing belts for wear and tension ¹	See Section 4.3	Daily										
Check infeed rollers	See Section 4.5	Daily										
Check blade drive shaft	See Section 4.6	Daily										
Inspect kickback fingers	See Section 4.8	Daily										
PROCEDURE	REFERENCE		TOTAL HOURS OF OPERATION FILL IN THE DATE AND THE MACHINE HOURS AS YOU PERFORM EACH PROCEDURE. A SHADED BOX INDICATES MAINTENANCE IS NOT NEEDED AT THIS TIME.									
Check feed/laser drive chain tension	See Section 4.4		40 HRS	80 HRS	120 HRS	160 HRS	200 HRS	240 HRS	280 HRS	320 HRS	360 HRS	400 HRS
Lubricate blade shaft and roller bearings	See Section 4.6											

¹ Check more frequently during the first 24-48 hours of operation.

MAINTENANCE LOG		TOTAL HOURS OF OPERATION									
PROCEDURE	REFERENCE	FILL IN THE DATE AND THE MACHINE HOURS AS YOU PERFORM EACH PROCEDURE. A SHADED BOX INDICATES MAINTENANCE IS NOT NEEDED AT THIS TIME.									
Check feed/laser drive chain tension	See Section 4.4	440 HRS	480 HRS	520 HRS	560 HRS	600 HRS	640 HRS	680 HRS	720 HRS	760 HRS	800 HRS
Lubricate blade shaft and roller bearings	See Section 4.6										

MAINTENANCE LOG		TOTAL HOURS OF OPERATION									
PROCEDURE	REFERENCE	FILL IN THE DATE AND THE MACHINE HOURS AS YOU PERFORM EACH PROCEDURE. A SHADED BOX INDICATES MAINTENANCE IS NOT NEEDED AT THIS TIME.									
Check feed/laser drive chain tension	See Section 4.4	840 HRS	880 HRS	920 HRS	960 HRS	1000 HRS	1040 HRS	1080 HRS	1120 HRS	1160 HRS	1200 HRS
Lubricate blade shaft and roller bearings	See Section 4.6										

MAINTENANCE LOG

PROCEDURE	REFERENCE	TOTAL HOURS OF OPERATION									
		FILL IN THE DATE AND THE MACHINE HOURS AS YOU PERFORM EACH PROCEDURE. A SHADED BOX INDICATES MAINTENANCE IS NOT NEEDED AT THIS TIME.									
		1240 HRS	1280 HRS	1320 HRS	1360 HRS	1400 HRS	1440 HRS	1480 HRS	1520 HRS	1560 HRS	1600 HRS
Check feed/laser drive chain tension	See Section 4.4										
Lubricate blade shaft and roller bearings	See Section 4.6										

MAINTENANCE LOG

PROCEDURE	REFERENCE	TOTAL HOURS OF OPERATION									
		FILL IN THE DATE AND THE MACHINE HOURS AS YOU PERFORM EACH PROCEDURE. A SHADED BOX INDICATES MAINTENANCE IS NOT NEEDED AT THIS TIME.									
		1640 HRS	1680 HRS	1720 HRS	1760 HRS	1800 HRS	1840 HRS	1880 HRS	1920 HRS	1960 HRS	2000 HRS
Check feed/laser drive chain tension	See Section 4.4										
Lubricate blade shaft and roller bearings	See Section 4.6										

MAINTENANCE LOG

PROCEDURE	REFERENCE	TOTAL HOURS OF OPERATION									
		FILL IN THE DATE AND THE MACHINE HOURS AS YOU PERFORM EACH PROCEDURE. A SHADED BOX INDICATES MAINTENANCE IS NOT NEEDED AT THIS TIME.									
		2040 HRS	2080 HRS	2120 HRS	2160 HRS	2200 HRS	2240 HRS	2280 HRS	2320 HRS	2360 HRS	2400 HRS
Check feed/laser drive chain tension	See Section 4.4										
Lubricate blade shaft and roller bearings	See Section 4.6										

MAINTENANCE LOG

PROCEDURE	REFERENCE	TOTAL HOURS OF OPERATION									
		FILL IN THE DATE AND THE MACHINE HOURS AS YOU PERFORM EACH PROCEDURE. A SHADED BOX INDICATES MAINTENANCE IS NOT NEEDED AT THIS TIME.									
		2440 HRS	2480 HRS	2520 HRS	2560 HRS	2600 HRS	2640 HRS	2680 HRS	2720 HRS	2760 HRS	2800 HRS
Check feed/laser drive chain tension	See Section 4.4										
Lubricate blade shaft and roller bearings	See Section 4.6										

SECTION 5 REPLACEMENT PARTS

5.1 How To Use The Parts List

- Use the table of contents to locate the assembly that contains the part you need.
- Go to the appropriate section and locate the part in the illustration.
- Use the number pointing to the part to locate the correct part number and description in the table.
- Parts shown indented under another part are included with that part.

To Order Parts

- From the continental US, call **1-800-525-8100** to order parts. Have your customer number, vehicle identification number, and part numbers ready when you call.
- From other international locations, contact the Wood-Mizer distributor in your area for parts.

5.2 Sample Assembly



REF	PART #	DESCRIPTION	COMMENTS	QTY.
	012345	SAMPLE ASSEMBLY, COMPLETE	INCLUDES ITEMS 1-6	1
1	F02222-22	Sample Part		1
2	F03333-33	Sample Part		2
	098765	Sample Subassembly	Includes items 3-6	1
3	S04444-44	Subassembly Sample Part		1
4	K55555	Subassembly Sample Part		1
	054321	Sample Sub-Subassembly	Includes items 5-6	2
5	022222	Sub-Subassembly Sample Part		1
6	F10234-56	Sub-Subassembly Sample Part		1

The Sample Assembly, Complete, part number 02345 (top level assembly) includes two parts (F0222-22 and F0333-33) and the 098765 subassembly.

Subassembly 098765 contains two parts(S04444-44 and K55555) and two copies of sub-subassembly 054321.

Each sub-subassembly 054321 contains two parts (022222 and F10234-56).

5.3 Torque Values

Grade		Units	SAE 5	SAE 8
Grade Mark				
Bolt Dia.	Threads. Per In.	Units	SAE 5	SAE 8
6	32	in-lbs (Nm)	20 (2.3)	-
8	32	in-lbs (Nm)	24 (2.7)	30 (3.4)
10	24	in-lbs (Nm)	35 (4.0)	45 (5.1)
10	32	in-lbs (Nm)	40 (4.5)	50 (5.7)
12	24	in-lbs (Nm)	50 (5.7)	65 (7.3)
1/4	20	in-lbs (Nm)	95 (10.7)	125 (14.1)
1/4	28	in-lbs (Nm)	95 (10.7)	150 (17.0)
5/16	18	ft-lbs (Nm)	17 (22.6)	23 (31.2)
5/16	24	ft-lbs (Nm)	20 (27.1)	25 (33.8)
3/8	16	ft-lbs (Nm)	30 (40.7)	40 (54.2)
3/8	24	ft-lbs (Nm)	35 (47.5)	45 (61.0)
7/16	14	ft-lbs (Nm)	50 (67.8)	65 (88.1)
7/16	20	ft-lbs (Nm)	55 (74.6)	70 (94.9)
1/2	13	ft-lbs (Nm)	75 (101.7)	100 (135.6)
1/2	20	ft-lbs (Nm)	85 (115.3)	110 (149.2)
9/16	12	ft-lbs (Nm)	105 (142.4)	135 (183.1)
9/16	18	ft-lbs (Nm)	115 (155.9)	150 (203.4)
5/8	11	ft-lbs (Nm)	150 (203.4)	195 (264.4)
5/8	18	ft-lbs (Nm)	160 (217.0)	210 (284.8)
3/4	10	ft-lbs (Nm)	170 (230.5)	220 (298.3)
3/4	16	ft-lbs (Nm)	175 (237.3)	225 (305.1)
7/8	9	ft-lbs (Nm)	302 (409.5)	473 (640.9)
7/8	14	ft-lbs (Nm)	300 (406.8)	400 (542.4)
1	8	ft-lbs (Nm)	466 (631.8)	714 (967.4)

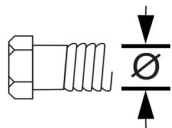

Metric Bolt Head Identification



8.8
Metric Grade 8.8



10.9
Metric Grade 10.9

COARSE THREAD					FINE THREAD				Wrench Size	
Diameter & Thread Pitch	Metric 8.8		Metric 10.9		Diameter & Thread Pitch	Metric 8.8		Metric 10.9		
	N-m	lbs-ft	N-m	lbs-ft		N-m	lbs-ft	N-m		lbs-ft
6 x 1.0	8	6	11	8					10 mm	
8 x 1.25	20	15	27	20	8 x 1.0	21	16	29	22	13 mm
10 x 1.5	39	29	54	40	10 x 1.25	41	30	57	42	16 mm
12 x 1.75	68	50	94	70	12 x 1.25	75	55	103	76	18 mm
14 x 2.0	109	80	151	111	14 x 1.5	118	87	163	120	21 mm
16 x 2.0	169	125	234	173	16 x 1.5	181	133	250	184	24 mm
18 x 2.5	234	172	323	239	18 x 1.5	263	194	363	268	27 mm
20 x 2.5	330	244	457	337	20 x 1.5	367	270	507	374	30 mm
22 x 2.5	451	332	623	460	22 x 1.5	495	365	684	505	34 mm
24 x 3.0	571	421	790	583	24 x 2.0	623	459	861	635	36 mm
30 x 3.0	1175	867	1626	1199	30 x 2.0	1258	928	1740	1283	46 mm

5.1 Infeed Table Assembly

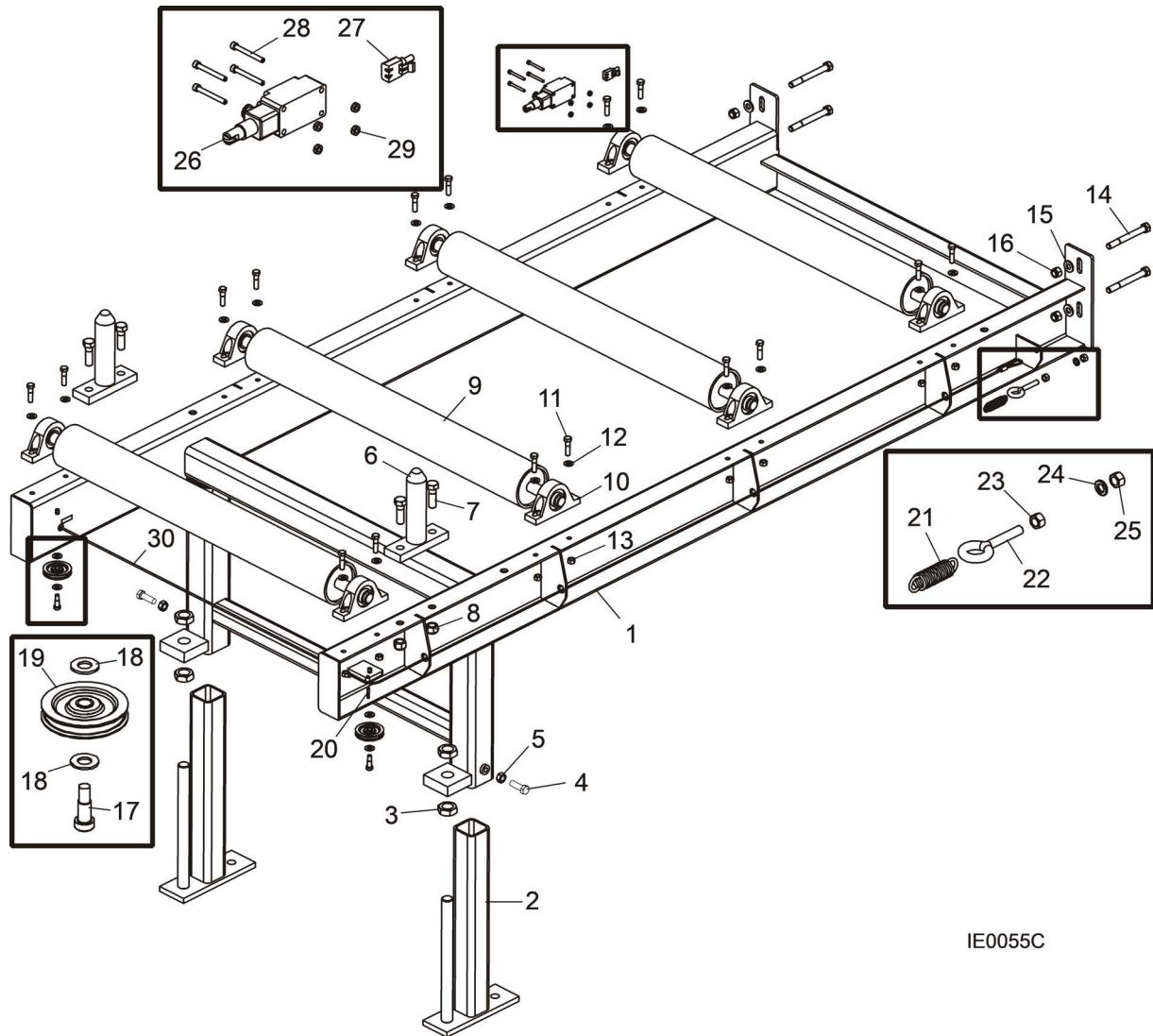

IE0055C

REF	PART #	DESCRIPTION	COMMENTS	QTY.
	039142	INFEED ASSEMBLY, EDGER		1
1	039133	Frame Weldment, Infeed		1
	039143	Foot Assembly, Edger		2
2	039115	Foot Weldment, Edger		1
3	F05010-118	Nut, 1-14 Hex Jam		2
4	F05008-33	Bolt, 1/2-13 x 1 1/2" Hex Head Grade 5		2
5	F05010-35	Nut, 1/2-13 Free Hex		2
6	039118	Shaft Weldment, Board Pivot		2
7	F05009-2	Bolt, 5/8-11 x 2" Hex Head Grade 2		4
8	F05010-34	Nut, 5/8-11 Nylon Lock		4
	039140	Roller Assembly, Infeed		4
9	039122	Roller Weldment, Infeed		1
10	039141	Bearing, 1 Pillow Block Lock		2
11	F05007-78	Bolt, 3/8-16 x 1 1/2" Hex Head Grade 5		4
12	F05011-3	Washer, 3/8" Flat		4

REF	PART #	DESCRIPTION	COMMENTS	QTY.
13	F05010-25	Nut, 3/8-16 Swaged		4
14	F05008-35	Bolt, 1/2-13 x 4 1/2" Hex Head Grade 5		4
15	F05011-2	Washer, 1/2" SAE Flat		4
16	F05010-8	Nut, 1/2-13 Nylon Hex Lock		4
17	F05007-79	Bolt, 3/8" x 5/8" Shoulder		2
18	F05011-3	Washer, 3/8" Flat		4
19	P07996	Pulley, 2 1/2" Nylon		2
20	F05012-11	Pin, 3/16" x 1" Zinc Roll		2
21	015479	Spring, 3/4 x 2 7/8 x 12 Ga		1
22	F05007-30	Bolt, 3/8-16 x 2" Turned Eye		1
23	F05010-29	Nut, 3/8-16 Hex Jam		1
24	F05011-4	Washer, 3/8" Split		1
25	F05010-1	Nut, 3/8-16 Hex		1
	052155	Switch Assembly, Perimeter Safety Pull w /Reset		1
26	052154	Switch, Cable Pull Normal Stop w/Reset		1
27	024262-2	Connector, 2P Plug Housing		1
28	F05004-192	Screw, 10-24 x 1 3/4" Socket Head Cap		4
29	F05010-14	Nut, #10-24 Keps		2
30	039381	Cable Assembly, Safety Switch		1

5.2 Blade and Laser Drives

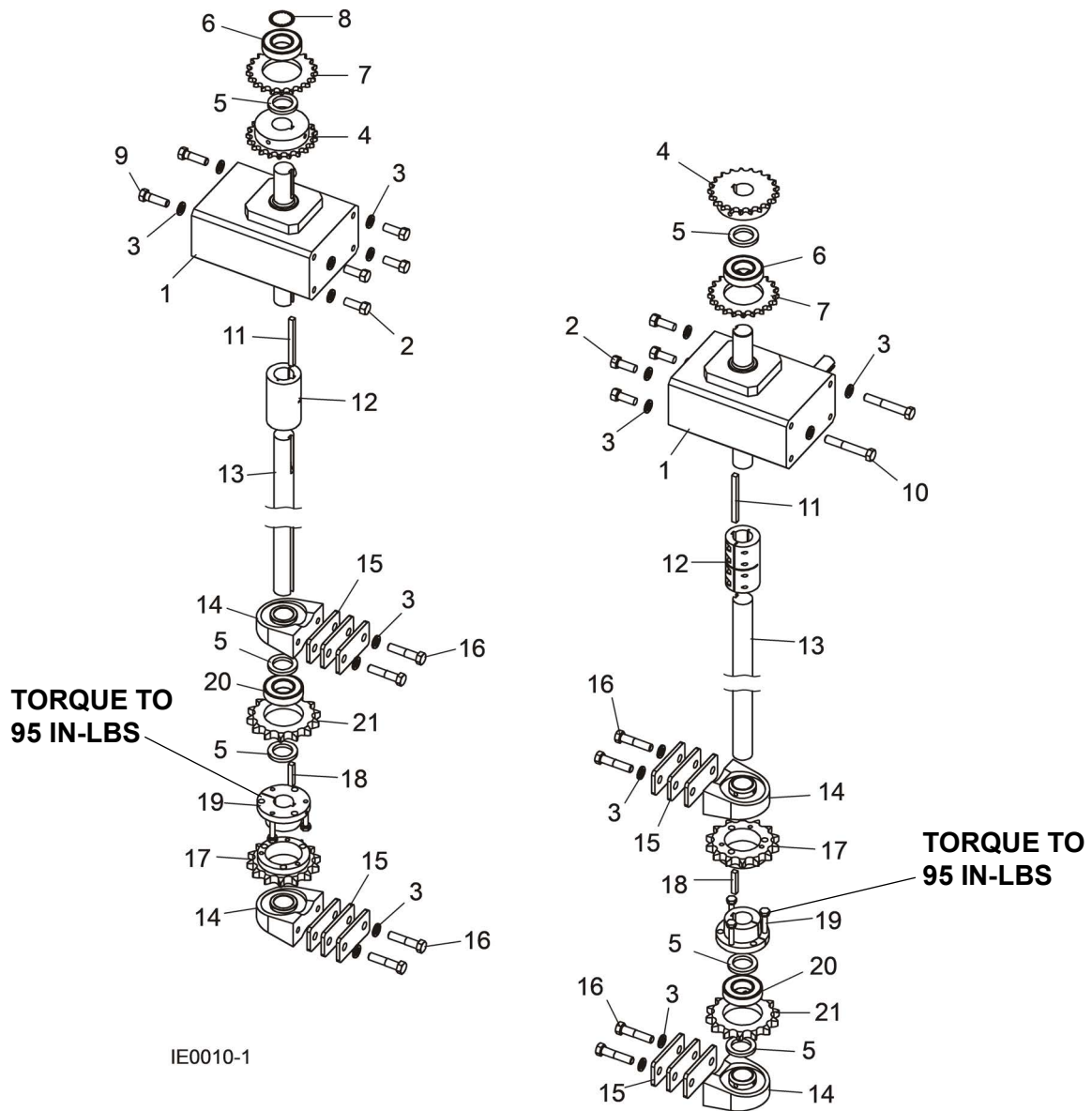

REF	PART #	DESCRIPTION	COMMENTS	QTY.
1	039203	Gearbox, IO60-60:1-RL		2
2	F05007-7	Bolt, 3/8-16x1 Hex Head		8
3	F05011-4	Washer, 3/8 Split		20
4	039197	Sprocket, 40B21 x 1		2
5	039250	Spacer, 1 1/64 ID x 1 1/2 OD x 3/16		6
	039201	Sprocket Assembly, 4021 Idler		2
6	042360	Bearing, R16 Sealed		1
7	039199	Sprocket, 40A21 Bored		1
8	F04254-40	Ring, 1 Dia Push Nut 5115-100		1
9	F05007-123	Bolt, 3/8-16x 1 1/4 Hex Head Gr5		2
10	F05007-125	Bolt, 3/8-16 x 2 1/2 Hex Head Gr5		2
11	S04124	Key, 1/4 x 1 11/16		4
12	039193	Coupler, 1 In Clamp Style		2
13	039208	Shaft, Blade Drive		2

REF	PART #	DESCRIPTION	COMMENTS	QTY.
14	039204	Bearing, MTBS-216		4
15	039205	Plate, Bearing Riser		12
16	F05007-119	Bolt, 3/8-16 UNF-2A x 1-3/4 Gr5		8
17	039195	Sprocket, H60SH14		2
18	017832	Key, 1/4Sq x 1 3/8		2
19	039202	Bushing, SH x 1		2
	039200	SPROCKET ASSEMBLY, 6014 IDLER		2
20	042360	Bearing, R16 Sealed		1
21	039198	Sprocket, 60A14 Bored		1

5.3 Laser Drive Motor

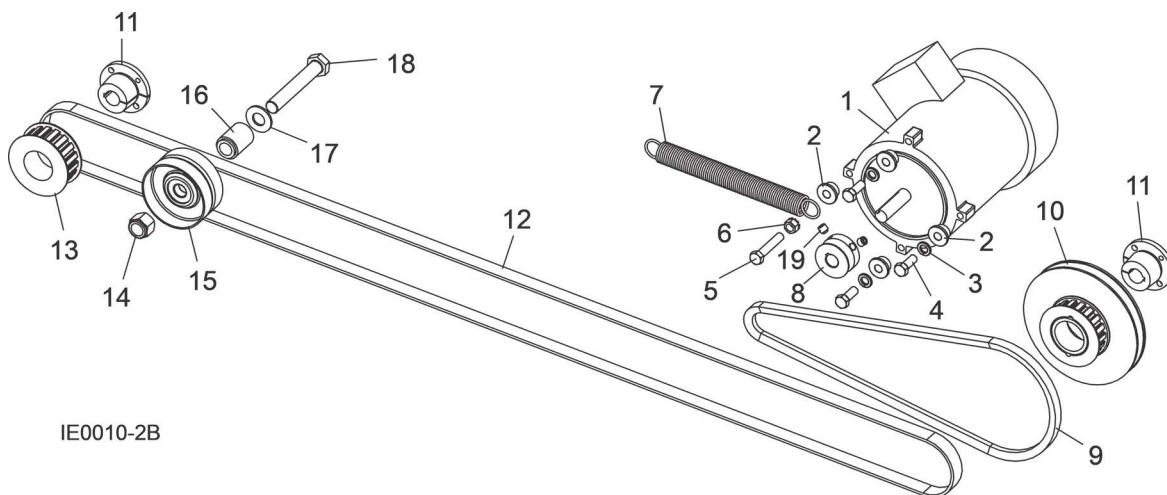

IE0010-2B

REF	PART #	DESCRIPTION	COMMENTS	QTY.
1	130062	MOTOR, LEESON 1/2HP 1725RPM		1
2	039182	BOSS, MOTOR MOUNT		4
3	F05011-4	WASHER, 3/8 SPLIT		3
4	F05007-87	BOLT, 3/8-16 X 1 HEX HEAD GR5		3
5	F05007-16	BOLT, 3/8-16 X 2 HEX HEAD FT		1
6	F05010-19	NUT, 3/8-16 KEPS		1
7	039303	SPRING, 1 OD X .105 X 9 EXT.		1
8	015135	SHEAVE, 1 3/4 FEED MOTOR		1
9	039276	BELT, 4L390		1
10	039326	SPROCKET/SHEAVE ASSEMBLY, BLADE IN/OUT		1
11	039323	BUSHING, H 3/4		2
12	039320	BELT, TIMING 1/2 PITCH 200 T 3/4 WIDE		1
13	039321	SPROCKET, TIMING 1/2 PITCH 18T 1 WIDE		1
14	F05010-71	NUT, 5/8-18 NYLON ZINC LOCK		1
15	041701	PULLEY, 3-1/4 OD IDLER		1
16	039348	TUBE, SPACER 41/64 X 1 1/8 X 1 17/32		1
17	F05011-5	WASHER, 5/8 SAE FLAT		1
18	F05009-98	BOLT, 5/8-18 X 3 1/4 HEX HEAD GR 5		1
19	F05007-68	SCREW, 3/8-16 X 3/8" SH CUP PT SET		2

5.4 Laser Guides Housing

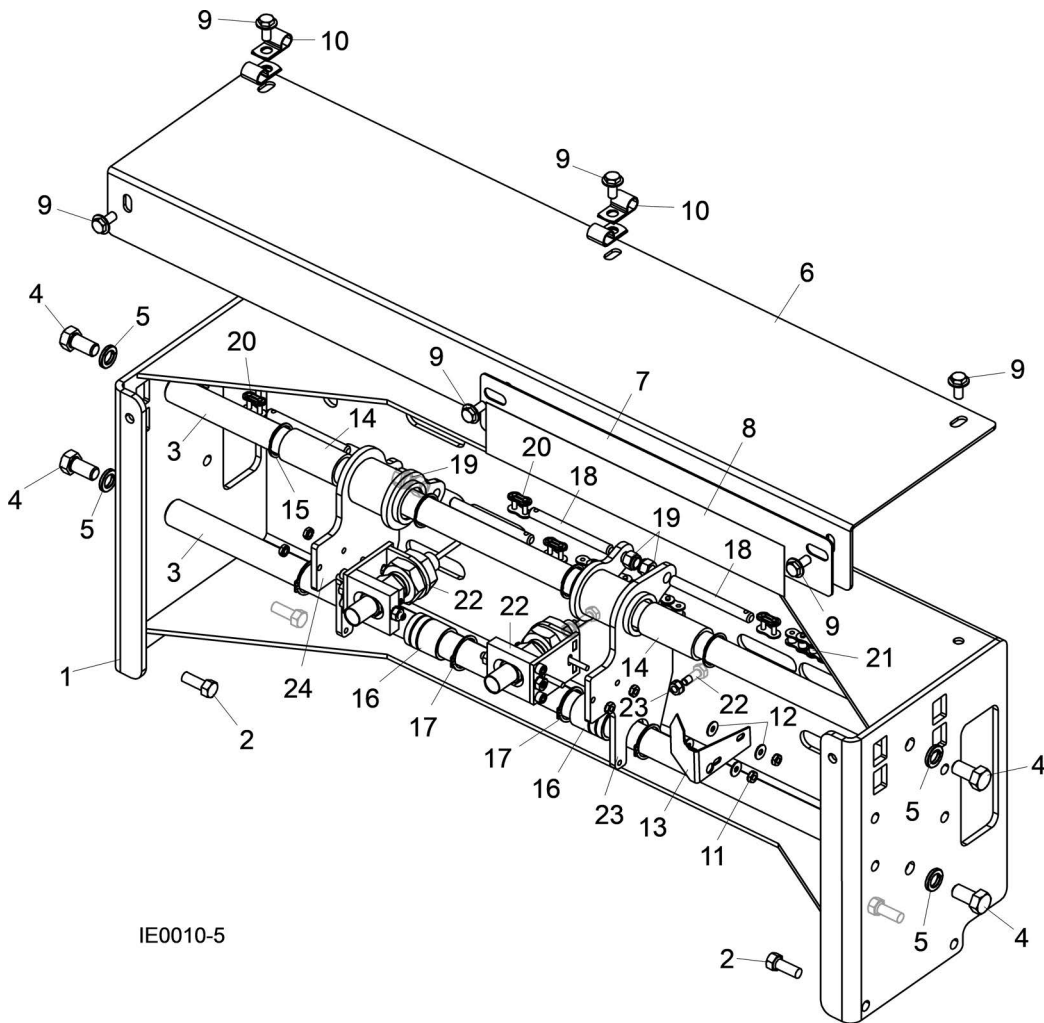

REF	PART #	DESCRIPTION	COMMENTS	QTY.
1	039185	BOX WELDMENT, LASER GUIDE		1
2	F05007-7	BOLT, 3/8-16 X 1 HEX HEAD		4
3	039206	ROD, LASER SLIDE		2
4	F05008-50	BOLT, 1/2-13X1 HEX HEAD		4
5	F05011-9	WASHER, 1/2 SPLIT LOCK		4
6	039360	COVER WELDMENT, LASER BOX TOP		1
7	039361	PLATE, BLADE SCALE MOUNT		1
8	039356	DECAL, BLADE SCALE (4-28)		1
9	F05006-101	BOLT, 5/16-18 X 3/4 HEX HEAD W/WASHER		6
10	P07584	CLAMP, 1/2 EMT COATED		4
11	F05010-14	NUT, #10-24 KEPS		2
12	F05011-18	WASHER, #10 SAE FLAT		4
13	039359	POINTER, BLADE SCALE		1
14	039254	BUSHING, 1 X 1 1/4 X 2 1/2 BRONZE		2
15	F04254-42	RING, 1 1/4 SPIRAL RETAINING		4
16	039253	BUSHING, 1 X 1 1/4 X 1 1/2 W/GROOVES		2
17	F04254-43	RING, 1 1/4 EXTERNAL 5100-125		4
18	039192	ROD, 40 CHAIN TENSIONER		4

5 Replacement Parts

Laser Guides Housing

REF	PART #	DESCRIPTION	COMMENTS	QTY.
19	F05010-10	NUT, 3/8-16 HEX NYLON LOCK		4
20	P04200	LINK, #40 MASTER		4
21	039333	CHAIN, #40 X 83 1/2		2
22		LASER ASSEMBLY, EG400 (<i>(See Section 5.5)</i>)		
23	039183	GUIDE WELDMENT, LASER LEFT		1
24	039184	GUIDE WELDMENT, LASER RIGHT		1

5.5 Laser Guides

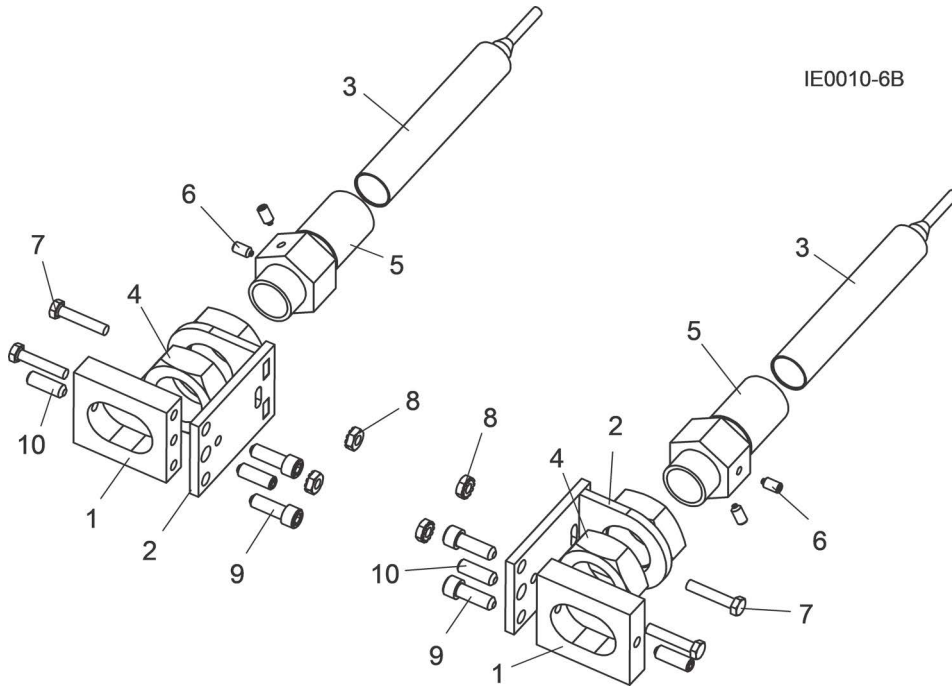

REF	PART #	DESCRIPTION	COMMENTS	QTY.
	039376	LASER ASSEMBLY, E430/EG400		2
1	110830	Block, Laser Adjust, 19mm		1
2	039374	Mount Weldment, E430/EG400 Laser		1
3	110828	Laser, 60 Deg, 15MW Line, CL-815WC		1
4	F05010-118	Nut, 1-14 Hex Jam ZC		1
5	110829	Sleeve, Laser Mount, 19mm		1
6	F05004-208	Screw, #10-32 x 3/8 Socket Head Set, Nylon		2
7	F05004-156	Bolt, #10-24 x 1 Unslotted Hex Head		2
8	F05010-14	Nut, #10-24 Keps		2
9	F05005-26	Screw, 1/4-20 x 3/4 BO Socket Head		2
10	F05005-94	Screw, 1/4-20x3/4 SH CP Nyl Lock		2

5.6 Blades Assembly

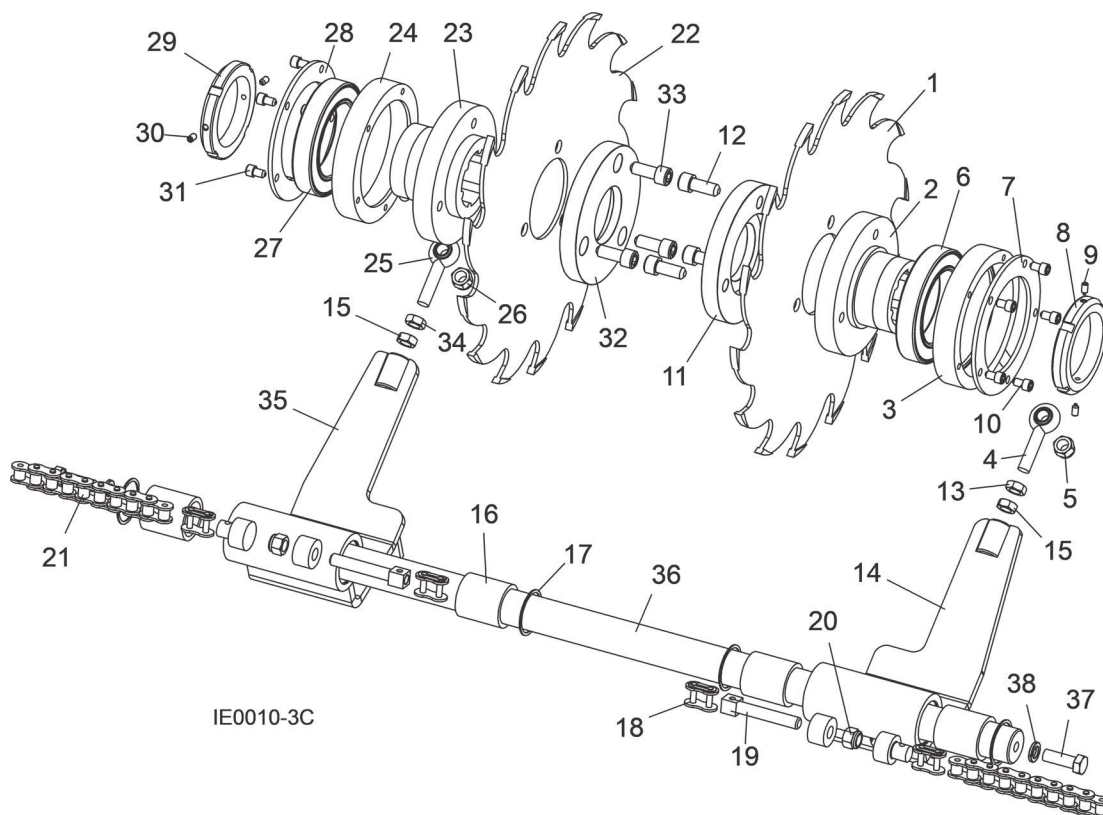

REF	PART #	DESCRIPTION	COMMENTS	QTY.
	039327	COLLAR ASSEMBLY, BLADE		1
1	039234	Blade, 16" Dia. x 14 Tooth Edger		1
	039234-CT	Blade, 16" Dia. x 14 Tooth Edger w/Carbide Tip Inserts		1
	048337-10	Shank, Edger Blade Insert (pkg. of 10)		1.4 pkg.
	048337	Shank, Edger Blade Insert (pkg. of 50)		.28 pkg.
	048338-10	Insert, High Speed Steel Edger Blade Tooth (pkg. of 10)		1.4 pkg.
	048338	Insert, High Speed Steel Edger Blade Tooth (pkg. of 100)		.14 pkg.
	048339-10	Insert, Carbide Tip Edger Blade Tooth (pkg. of 10)		1.4 pkg.
	048339	Insert, Carbide Tip Edger Blade Tooth (pkg. of 110)		.13 pkg.
	048336	Wrench for Insert Edger Blade		1
2	039127	Collar, Industrial Edger Blade		1
3	039235	Collar Weldment, Bearing		1
4	P09137	Rod End, 1/2" Male		1
5	F05010-8	Nut, 1/2-13 Nylon Hex Lock		1
6	039233	Bearing, 6016-2RS		1
7	039012	Plate, Bearing Retaining		1
	036650	Nut Assembly, Arbor w/Set Screws		1
8	039129	Nut, AN16	Available in assemblies only.	1

REF	PART #	DESCRIPTION	COMMENTS	QTY.
9	F05005-166	Screw, 1/4-20 x 1/2" Nylon Tip Set		2
10	F05006-39	Bolt, 5/16-18 x 1/2" Socket Head		5
11	039128	Ring, Industrial Edger Blade Lock		1
12	F05008-38	Bolt, 1/2-13 x 1 1/4" Socket Head		3
13	F05010-16	Nut, 1/2-20 Hex Jam		1
14	039237	PUSHER WELDMENT, LEFT BLADE		1
15	F05010-16	NUT, 1/2-20 HEX JAM		2
16	039251	BUSHING, 1 7/8" OD X 1 1/2" ID X 2" BRONZE		4
17	F04254-41	RING, 1 7/8" SPIRAL RETAINING		4
18	042398	LINK, #60 CL		4
19	039191	ROD ASSEMBLY, CHAIN TENSIONER		2
20	F05010-8	NUT, 1/2-13 NYLON HEX LOCK		2
21	039370	CHAIN, #60 X 84 3/4"		2
	039239	COLLAR ASSEMBLY, BLADE		1
22	039234	Blade, 16" Dia. x 14 Tooth Edger		1
	039234-CT	Blade, 16" Dia. x 14 Tooth Edger w/Carbide Tip Inserts		1
	048337-10	Shank, Edger Blade Insert (pkg. of 10)		1.4 pkg.
	048337	Shank, Edger Blade Insert (pkg. of 50)		.28 pkg.
	048338	Insert, High Speed Steel Edger Blade Tooth		14 pkg.
	048339	Insert, Carbide Tip Edger Blade Tooth		14 pkg.
23	039127	Collar, Industrial Edger Blade		1
24	039235	Collar Weldment, Bearing		1
25	P09137	Rod End, 1/2" Male		1
26	F05010-8	Nut, 1/2-13 Nylon Hex Lock		1
27	039233	Bearing, 6016-2RS		1
28	039012	Plate, Bearing Retaining		1
	036650	Nut Assembly, Arbor w/Set Screws		1
29	039129	Nut, AN16	Available in assemblies only.	1
30	F05005-166	Screw, 1/4-20 x 1/2" Nylon Tip Set		2
31	F05006-39	Bolt, 5/16-18 x 1/2" Socket Head		5
32	039128	Ring, Industrial Edger Blade Lock		1
33	F05008-38	Bolt, 1/2-13 x 1 1/4" Socket Head		3
34	F05010-16	Nut, 1/2-20 Hex Jam		1
35	039236	PUSHER WELDMENT, RIGHT BLADE		1
36	039209	SHAFT, BLADE SLIDE		1
37	F05008-33	BOLT, 1/2-13X1 1/2 HH GR5		2
38	F05011-9	WASHER, 1/2 SPLIT LOCK		2
	048336	WRENCH, EDGER BLADE INSERT		1
	061106	Pin, Edger Blade Wrench Replacement		1

5.7 Blades Shaft

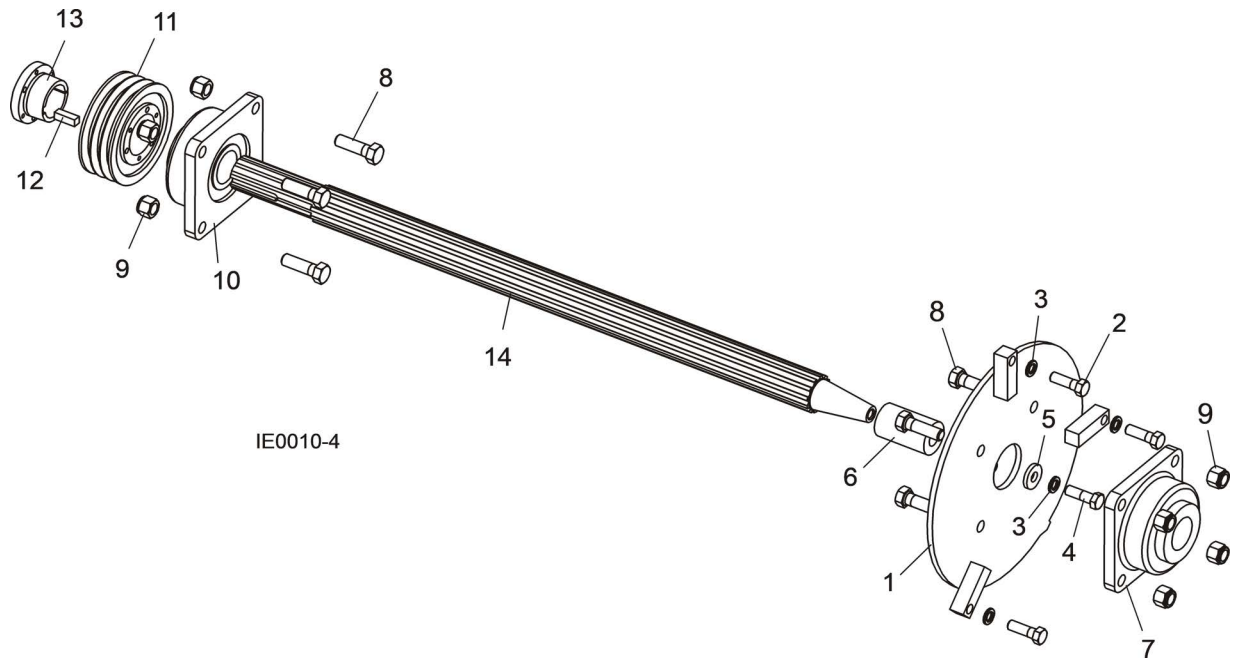

REF	PART #	DESCRIPTION	COMMENTS	QTY.
1	039338	DOOR WELDMENT, BLADE		1
2	F05009-20	BOLT, 5/8-11 X 2 1/2 GR5 HEX HEAD		3
3	F05011-27	WASHER, 5/8 SPLIT ZINC LOCK		4
4	F05009-15	BOLT, 5/8-18 X 2 HEX HEAD FT		1
5	034685	WASHER, 21/32 X 1 5/8 X 1/4 THICK		1
6	039001	CUP, BLADE DRIVE SHAFT		1
7	039150	BEARING, F-U335D		1
8	F05009-44	BOLT, 3/4-10 X 2 1/2 HEX HEAD GR5		8
9	F05010-103	NUT, 3/4-10 NYLOCK		8
10	039151	BEARING, FE-U335D		1
11	039269	SHEAVE, 35V670		1
12	033738	KEY, 1/2 SQ X 1 1/2		1
13	039267	BUSHING, SK X 2 3/16		1
14	039002	SHAFT, 2 7/16 DIA.		1

5.8 Blades Motor Assembly

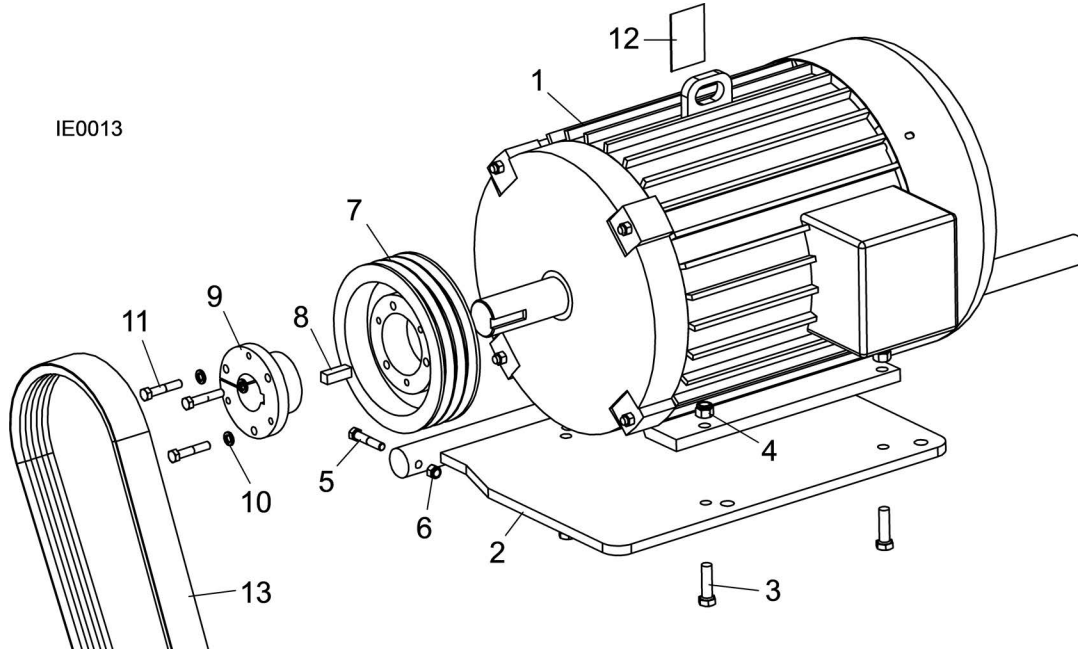

REF	PART #	DESCRIPTION	COMMENTS	QTY.
	039265	MOTOR ASSEMBLY, INDUSTRIAL EDGER		1
1	042301	Motor, Lincoln 30HP 1800RPM		1
2	039112	Mount Weldment, Motor		1
3	F05008-88	Bolt, 1/2-13 x 1 3/4 Hex Head GR5 Zinc		4
4	F05010-8	Nut, 1/2-13 Nylon Hex Lock		4
5	F05007-124	Bolt, 3/8-16 x 2 Hex Head Gr5		1
6	F05010-10	Nut, 3/8-16 Hex Nylon Lock		1
7	039268	Sheave, 35V850		1
8	033738	Key, 1/2 Sq x 1 1/2		1
9	039266	Bushing, SF x 1 7/8		1
10	F05011-4	Washer, 3/8 Split		3
11	F05007-72	Bolt, 3/8-16x2 Hex Head		3
12	S20097	Decal, Motor Direction		1
13	039270	BELT, 3 X 5V X 900		1

5.9 Feed Drive Assembly

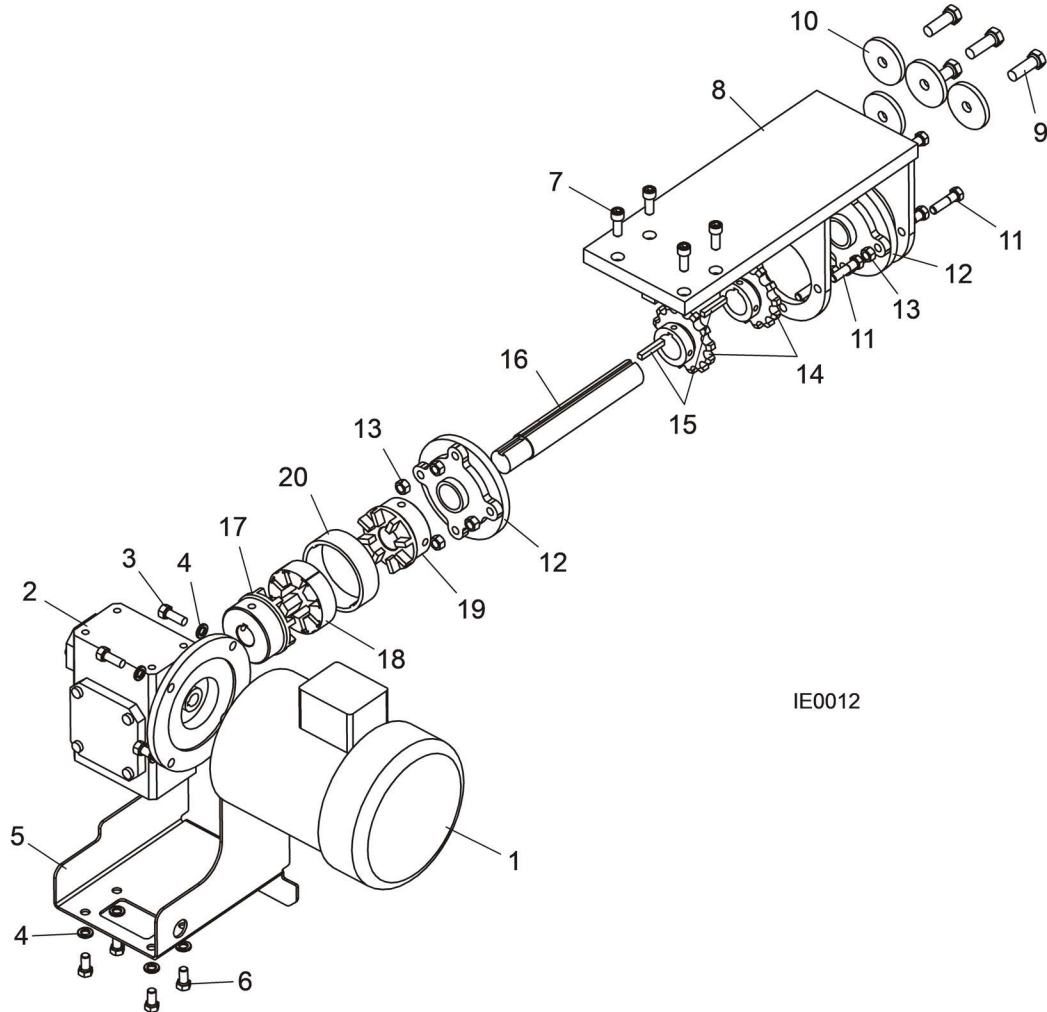

IE0012

REF	PART #	DESCRIPTION	COMMENTS	QTY.
	039249	DRIVE ASSEMBLY, EDGER FEED		1
1	079197	Motor, 2HP 3P 230/460 56C Premium Eff		1
2	042793	Gearbox, IC60 Up/Down		1
3	F05007-7	Bolt, 3/8-16 x 1 Hex Head		4
4	F05011-4	Washer, 3/8 Split		8
5	039339	Guard, Board Feed		1
6	F05007-27	Bolt, 3/8-16 x 3/4 Hex Head Gr2		4
7	F05007-52	Bolt, 3/8-16 x 1 Socket Head Cap BO		4
8	039138	Mount Weldment, Board Drive		1
9	F05008-33	Bolt, 1/2-13 x 1 1/2 Hex Head Gr5		4
10	033909	Washer, Drive Side Bearing		4
11	F05007-78	Bolt, 3/8-16 x 1 1/2 Hex Head Gr5		8

REF	PART #	DESCRIPTION	COMMENTS	QTY.
12	039152	Bearing, VFCS-320		2
13	F05010-25	Nut, 3/8-16 Swaged		8
14	039155	Sprocket, H6013 x 1.25 Bore Keyed		2
15	028080	Key, 1/4 Square x 1 1/2 Long		2
16	039214	Shaft, Edger Power Feed		1
	042655	Coupling, 10R x 1 x 1-1/8 Power Feed	Coupler set screws supplied with complete coupler 042655 or Coupling Spider 042655-2 only.	1
17	042655-1	Coupling Body, 10R x 1		1
18	042655-2	Coupling Spider, Urethane 10R w/Screws		1
19	042655-4	Coupling Body, 10R x 1-1/8		1
20	042655-5	Coupling Ring, Steel 10R		1

5 Replacement Parts

Upper Driven Roller

5.10 Upper Driven Roller

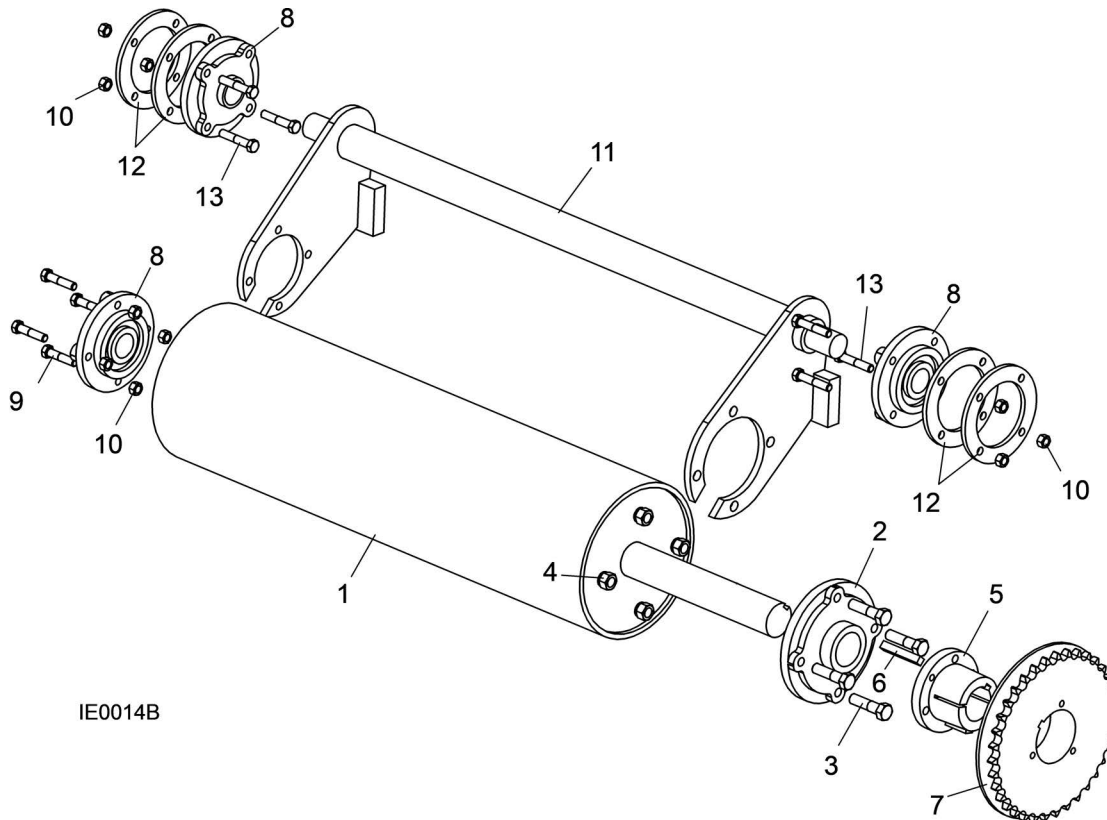

IE0014B

REF	PART #	DESCRIPTION	COMMENTS	QTY.
	039258	ROLLER ASSEMBLY, UPPER DRIVEN		1
1	039086	Roller Weldment, Infeed Holddown		1
2	039154	Bearing, VFCS-328		1
3	F05008-76	Bolt, 1/2-13 x 2 Hex Head		4
4	F05010-8	Nut, 1/2-13 Nylon Hex Lock		4
5	039260	Bushing, Q1 x 1 3/4		1
6	039380	Key, 3/8 Sq x 2 1/2		1
7	036484	Sprocket Wldmt, Feed Drive 60Q35		1
8	039152	Bearing, VFCS-320		3
9	F05007-119	Bolt, 3/8-16 UNF-2A x 1-3/4 Gr5		4
10	F05010-25	Nut, 3/8-16 Swaged Lock		10
11	039111	Pivot Weldment, Driven Holddown		1
12	039007	Spacer, Bearing		4
13	F05007-124	Bolt, 3/8-16 x 2 Hex Head Gr5		6

5.11 Lower Drive Rollers

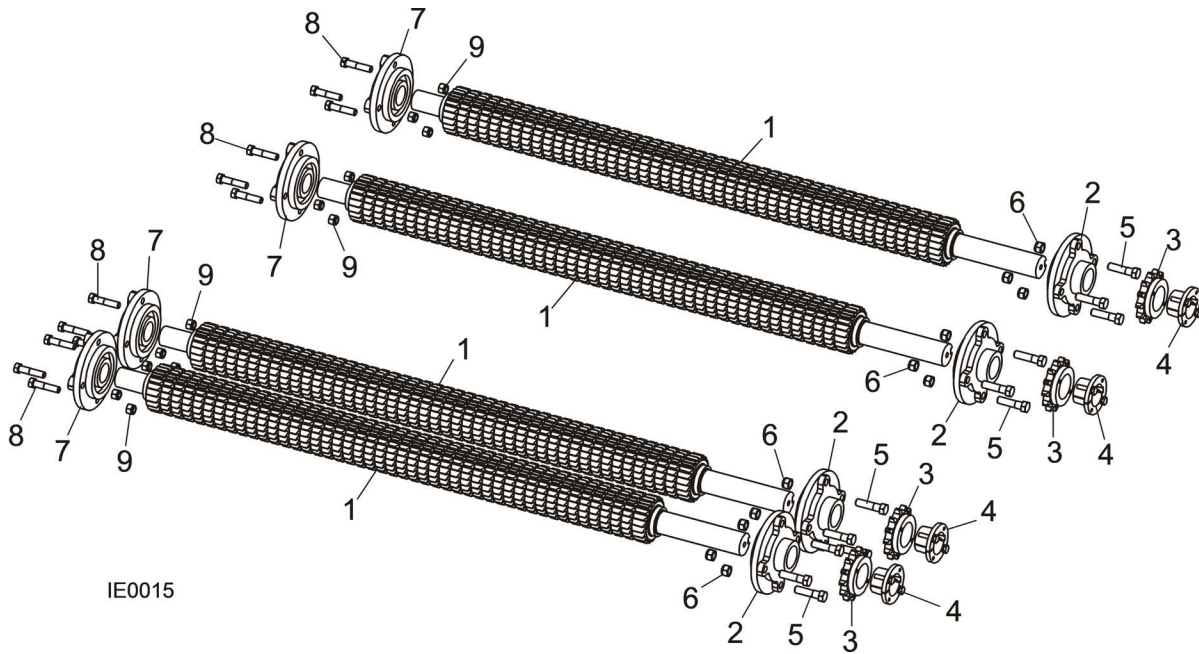

IE0015

REF	PART #	DESCRIPTION	COMMENTS	QTY.
	039255	ROLLER ASSEMBLY, LOWER DRIVE		4
1	039169	Shaft, Lower Drive		1
2	039153	Bearing, VFCS-323		1
3	039256	Sprocket, 60H13		1
4	P12962	Bushing, QT x 1 7/16		1
5	F05009-60	Bolt, 7/16-14 x 1 3/4 G8 Hex Head		3
6	F05010-135	Nut, 7/16-14 Nylon Lock		3
7	039152	Bearing, 1 1/4, 4 Bolt Flange		1
8	F05007-119	Bolt, 3/8-16 UNF-2A x 1-3/4 Gr5		3
9	F05010-10	Nut, 3/8-16 Hex Nylon Lock		3

5.12 Upper Idle Roller

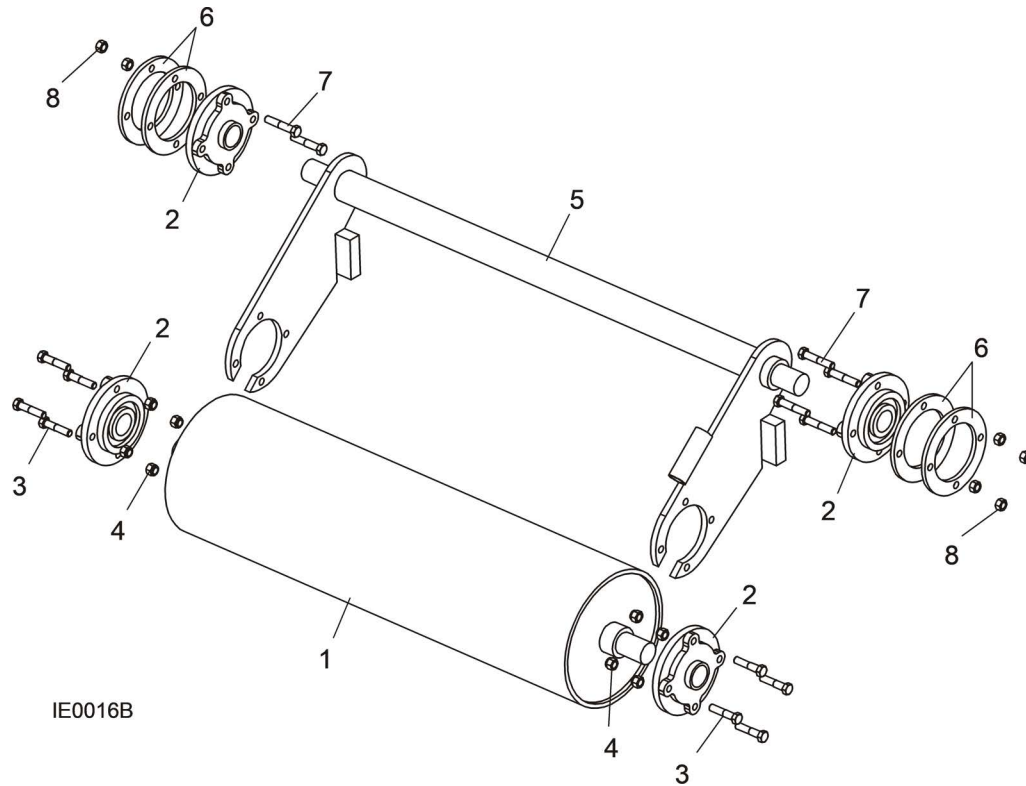

REF	PART #	DESCRIPTION	COMMENTS	QTY.
	039257	ROLLER ASSEMBLY, UPPER IDLE		1
1	039109	Roller Weldment, Idle Holddown		1
2	039152	Bearing, VFCS-320		4
3	F05007-119	Bolt, 3/8-16UNF-2A x 1-3/4" Grade 5		8
4	F05010-10	Nut, 3/8-16 Hex Nylon Lock		8
5	039110	Pivot Weldment, Idle Holddown		1
6	039007	Spacer, Bearing		4
7	F05007-124	Bolt, 3/8-16 x 2" Hex Head Grade 5		6
8	F05010-25	Nut, 3/8-16 Swagged		6

5.13 Tensioner Assembly

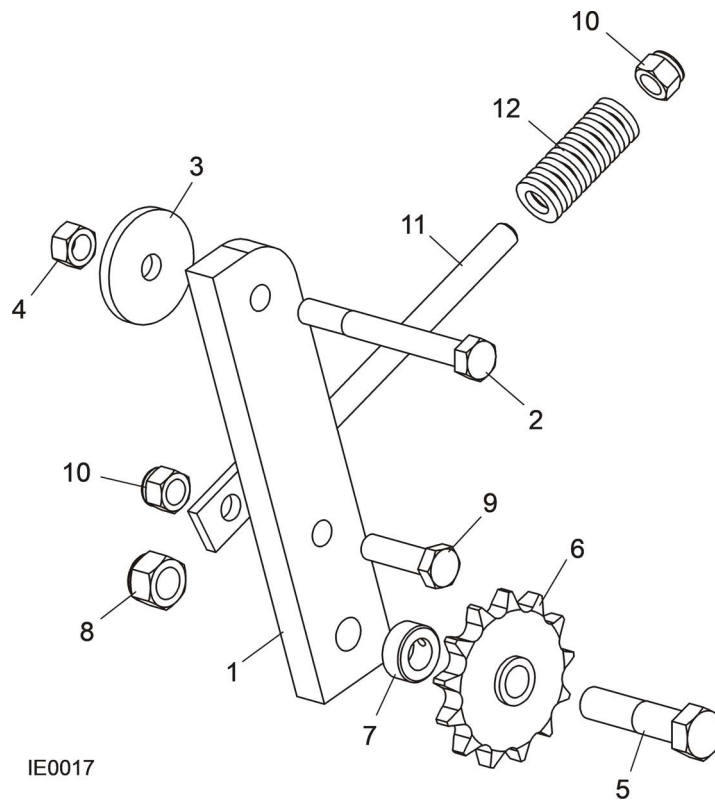

REF	PART #	DESCRIPTION	COMMENTS	QTY.
	039262	TENSIONER ASSEMBLY, INDUSTRIAL EDGER		1
1	039097	Block, Idler Pivot		1
2	F05008-35	Bolt, 1/2-13 x 4 1/2 Hex Head Gr5		1
3	033909	Washer, Drive Side Bearing		1
4	F05010-3	Nut, 1/2-13 Swaged Hex 2-way Lock		1
5	F05009-21	Bolt, 5/8-11 x 2 3/4 Hex Head		1
6	034224	Sprocket, 60BB13H x 5/8 Idler		1
7	P05035	Collar, 5/8 ID Lock		1
8	F05010-34	Nut, 5/8-11 Nylon Lock		1
9	F05008-88	Bolt, 1/2-13 x 1 3/4 Hex Head Gr5 Zinc		1
10	F05010-8	Nut, 1/2-13 Nylon Hex Lock		2
11	039116	Tensioner Weldment, Drive Chain		1
12	039263	Spring, EH100 x 250		1

5.14 Kickback Assembly

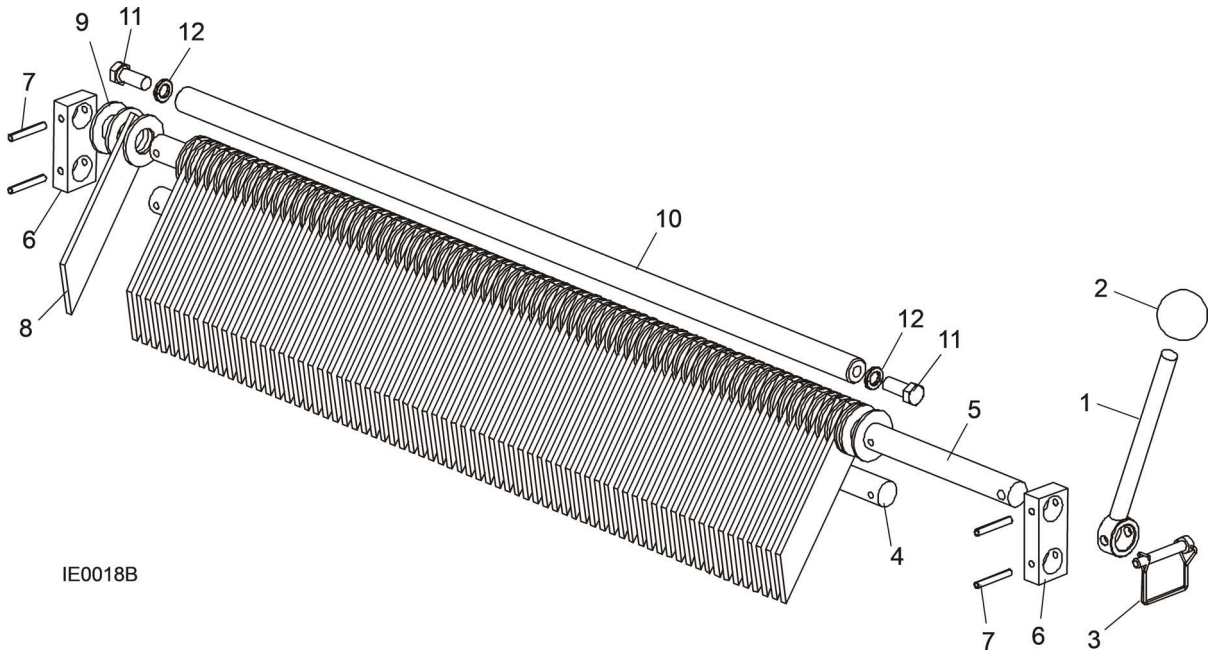

REF	PART #	DESCRIPTION	COMMENTS	QTY.
	039261	KICKBACK ASSEMBLY, INDUSTRIAL EDGER		1
1	039213	Handle Weldment, Kickback Lift		1
2	P04211	Knob, 5/8-18 Ball		1
3	014151	Pin, 3/8 x 2 1/4" SQ Wire Lock		1
4	039073	Shaft, Kickback Upper		1
5	039074	Shaft, Kickback Lower		1
6	039106	Block, Kickback Link		2
7	F05012-53	Pin, 1/4 x 1 3/4" Roll		4
8	038238	Finger, 1/4" Kickback		70
9	F05011-28	Washer, 1" ID SAE Flat		145
10	039387	Rod, Kickback Stop		1
11	F05008-37	Bolt, 1/2-13x1 1/4" Hex Head Grade 5		2
12	F05011-9	Washer, 1/2" Split Lock		2

5.15 Operator Control Assembly

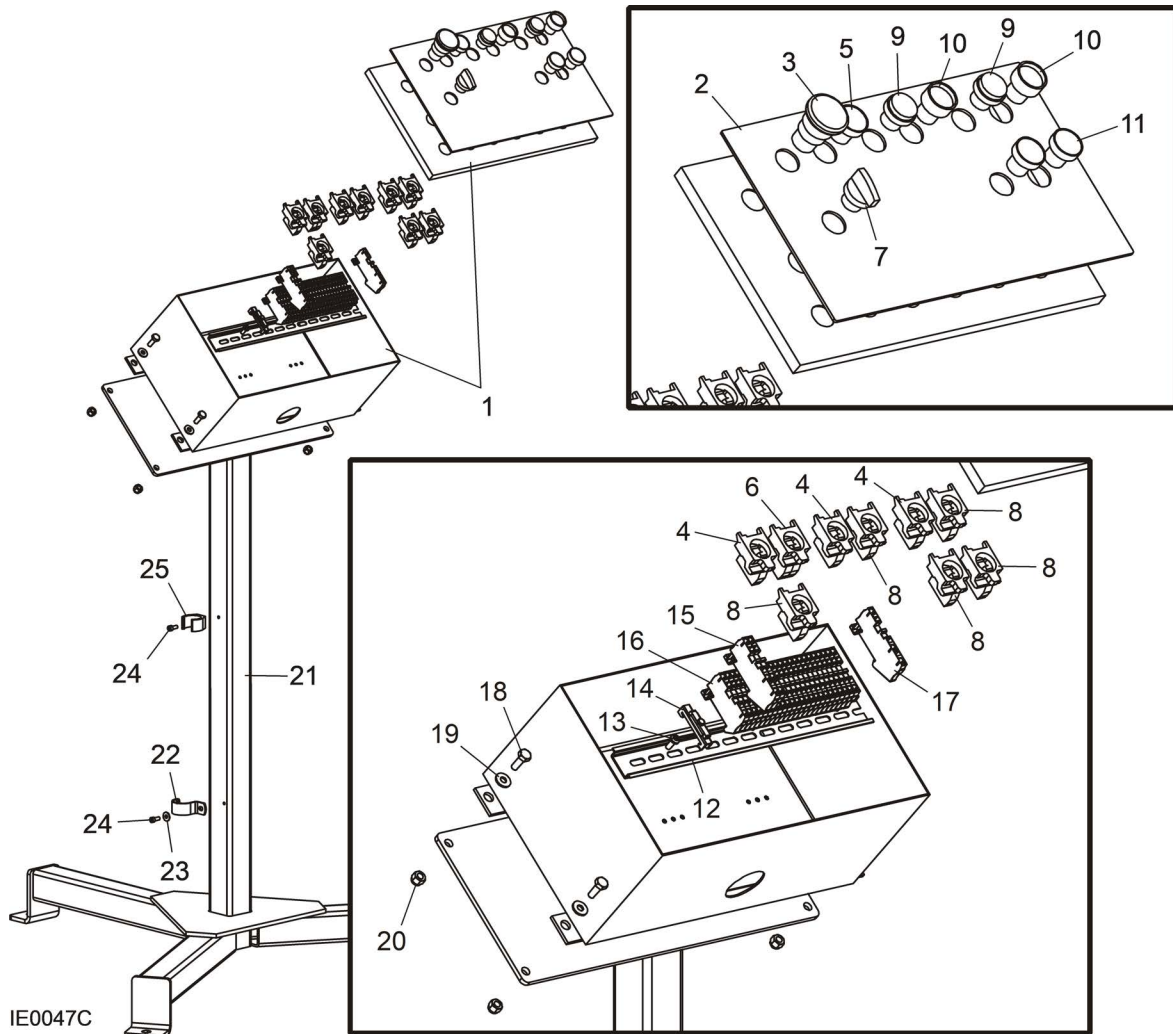

IE0047C

REF	PART #	DESCRIPTION	COMMENTS	QTY.
	039367	CONTROL ASSEMBLY, OPERATOR	See Section 5.22 if control equipped with optional Setworks.	1
	052739	Operator Assembly, Industrial Edger 2006		1
1	054667	Enclosure, E430/EG400 Setworks Operator		1
2	052769	Decal, E430 2006 Operator		1
3	024945	Switch Head, Red Push Button 22mm XB4		1
4	025161	Switch Body, 22mm 1NC XB4		3
5	051301	Switch Head, Green Flush ZB4		1
6	025236-31	Switch Body, 22mm Green LED 1NO 24V XB4		1
7	051302	Switch Head, 2 Pos. Maint. ZB4		1
8	025242	Switch Body, 22mm 1NO XB4		5
9	050151	Switch Body, Red Extended		2
10	050152	Switch Head, Green Guarded		2
11	050197	Switch Head, 22mm Mom Flush Blue XB4		2

5 Replacement Parts

Operator Control Assembly

REF	PART #	DESCRIPTION	COMMENTS	QTY.
12	024474-12_75	Rail, 35mm x 7.5mm x 12.75" Steel DIN		1
13	F05015-17	Bolt, #10-24 x 1/2" Phillips Pan Head		3
14	E22707	Clamp, Plastic DIN Rail		1
15	052760	Terminal Block, 3P Gray Cage Clamp		2
16	052750	Terminal Block, 2P Gray Cage Clamp		24
17	052752	Terminal Block, Green/Yellow GND 3P		1
	052748	Harness Assembly, Industrial Edger Control 2006		1
	052776	Hood, Top Entry 32P		1
	073750	Connector, 1-1/4" NPT 0.875-1.0 Straight		1
	052777	Insert, 16P Cage Clamp Male (1-16)		1
	052778	Insert, 16P Cage Clamp Male (17-32)		1
	073775	Connector, 1-1/4" NPT 0.875-1.0 45deg		1
18	F05005-1	Bolt, 1/4-20 x 3/4" Hex Head Full Thread		4
19	F05011-11	Washer, 1/4" SAE Flat		4
20	F05010-69	Nut, 1/4-20 Hex Nylon Lock		4
21	039336	Stand Weldment, Edger Control		1
22	P05436	Clamp, 1" EMT		1
23	F05011-18	Washer, #10 SAE Flat		1
24	F05004-26	Screw, #10-24 x 1/2" Socket Head		2
25	039379	Bracket, 3/4" Flex Mounting		1

5.16 Operator Control Assembly (w/Optional Networks)

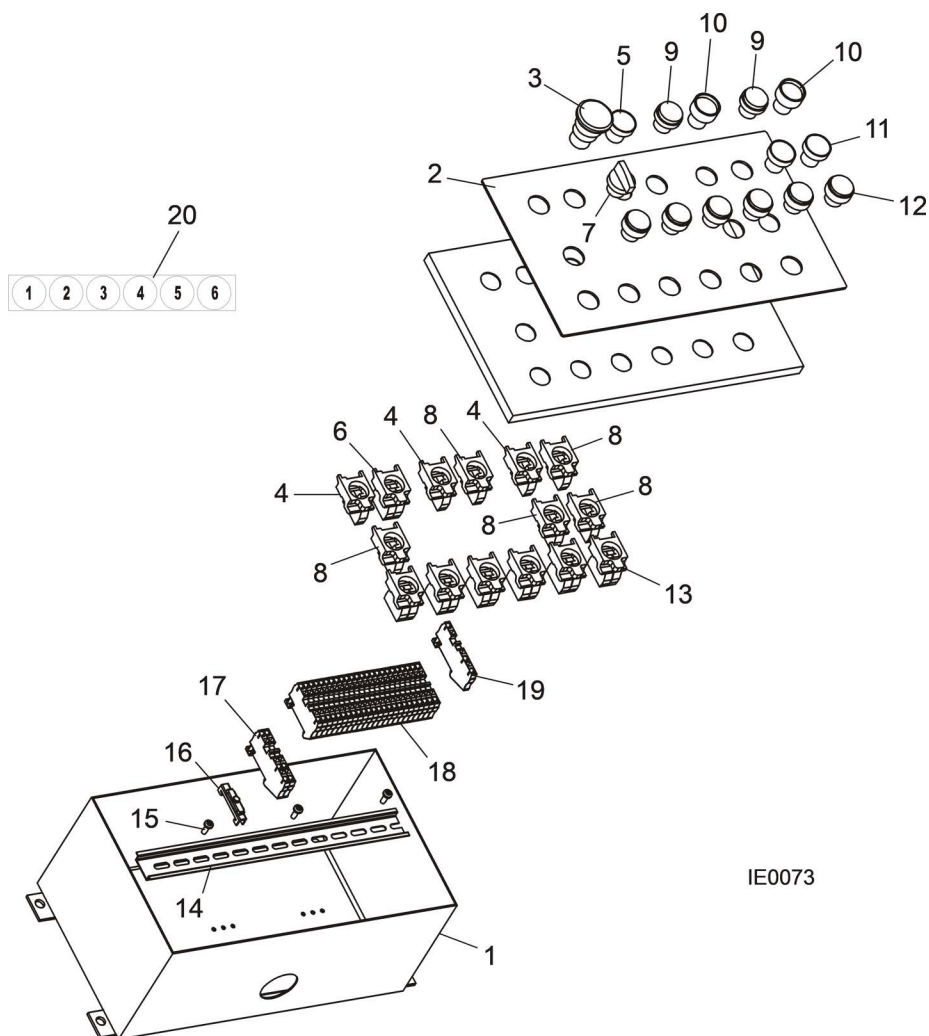

IE0073

REF	PART #	DESCRIPTION	COMMENTS	QTY.
	052770	OPERATOR ASSEMBLY, CONTROL W/SET- WORKS (FACTORY INSTALLED)		1
1	054667	Enclosure, E430/EG400 Networks Operator		1
2	054649	Decal, Industrial Edger Operator Control w/Setworks (AWMV)		1
3	024945	Switch Head, Red Push Button 22mm XB4		1
4	025161	Switch Body, 22mm 1NC XB4		3
5	051301	Switch Head, Green Flush ZB4		1
6	025236-31	Switch Body, 22mm Green LED 1NO 24V XB4		1
7	051302	Switch Head, 2 Pos. Maint. ZB4		1
8	025242	Switch Body, 22mm 1NO XB4		5
9	050151	Switch Body, Red Extended		2
10	050152	Switch Head, Green Guarded		2
11	050197	Switch Head, 22mm Mom Flush Blue XB4		2
12	025237-68	Switch, Head 22mm Mom Flush LED Blue XB4		6
13	025236-61	Switch Body, 22mm Blue LED 1 NO 24V XB4		6
14	024474-12_75	Rail, 35mm x 7.5mm x 12.75" Steel DIN		1

5 Replacement Parts

Operator Control Assembly (w/Optional Setworks)

REF	PART #	DESCRIPTION	COMMENTS	QTY.
15	F05015-17	Bolt, #10-24 x 1/2" Phillips Pan Head		3
16	E22707	Clamp, Plastic DIN Rail		1
17	052760	Terminal Block, 3P Gray Cage Clamp		2
18	052750	Terminal Block, 2P Gray Cage Clamp		24
19	052752	Terminal Block, Green/Yellow GND 3P		1
20	052822	Label Set, E430/EG400 Setworks Preset		1
	052748	Harness Assembly, Industrial Edger Control 2006		1
	052776	Hood, Top Entry 32P		1
	073750	Connector, 1-1/4" NPT 0.875-1.0 Straight		1
	052777	Insert, 16P Cage Clamp Male (1-16)		1
	052778	Insert, 16P Cage Clamp Male (17-32)		1
	073775	Connector, 1-1/4" NPT 0.875-1.0 45deg		1

5.17 Electrical Cabinet, Laser Interface & Harnesses

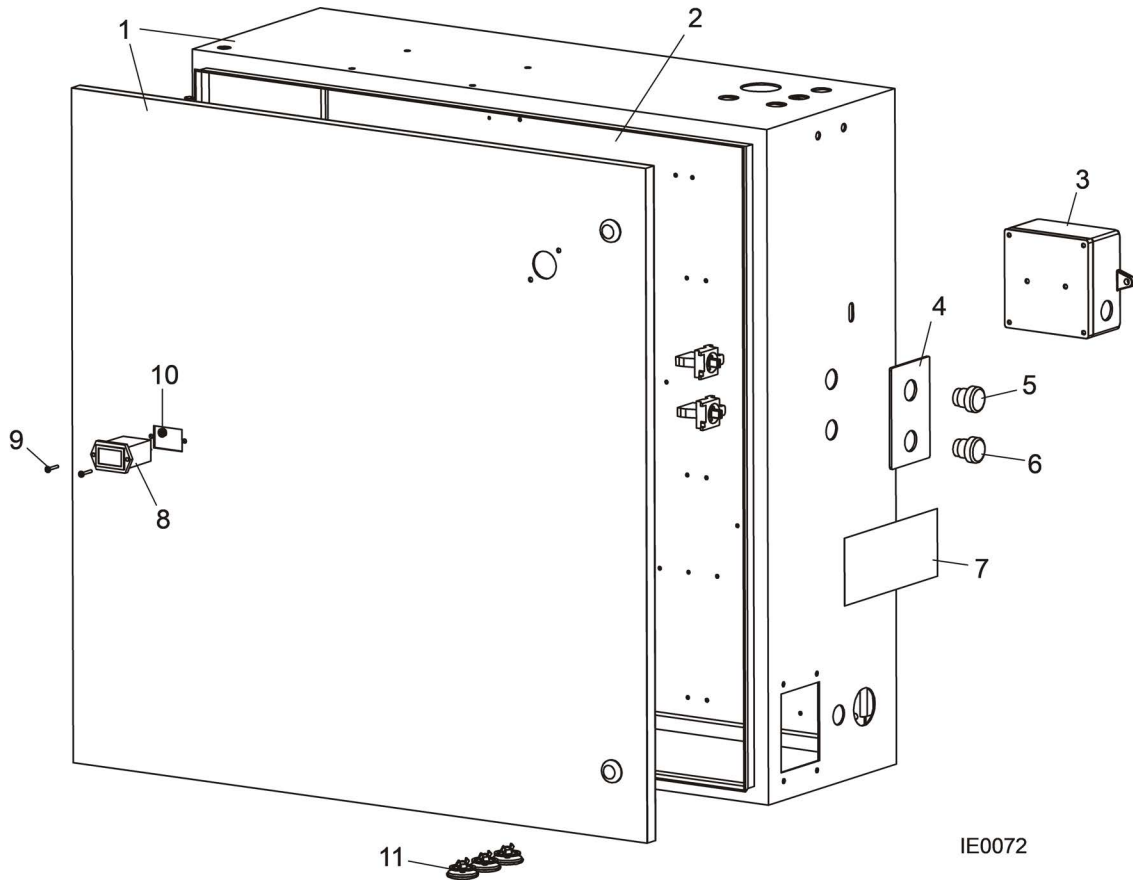

REF	PART #	DESCRIPTION	COMMENTS	QTY.
	052738	BOX ASSEMBLY, EDGER ELECTRICAL		1
1	054807	Enclosure, Industrial Edger Setworks Control		1
2		Electrical Components (<i>(See Section 6.2)</i>)		
	052749	Interface Assembly, Industrial Edger Laser 2006		1
3	051309	Enclosure Assembly, Industrial Edger Laser Interface		1
		Laser Interface Components (<i>(See Section 6.2)</i>)		
4	052289	Decal, Industrial Edger 2005 Status Lights		1
5	024970-3	Light, Green 24V 22mm LED XB4 Pilot		1
6	024970-4	Light, Red 24V 22mm LED XB4 Pilot		1
7	059506	Decal, Wood-Mizer Logo 6"		1
8	015401	Hour Meter, Rectangle Mount		1
9	F05004-93	Screw, #6-32 x 3/4" Socket Button Head Stainless Steel		2
10	F05010-59	Nut, #6-32 Self-Locking Hex		2
11	024685	Plug, AS050 OilTite		3
	052747	Connector Assembly, Industrial Edger Interface 2006		1
	052766	Insert, 16P Spring Clamp 1-16 Female		1
	052767	Insert, 16P Spring Clamp 17-32 Female		1

5 Replacement Parts
Electrical Cabinet, Laser Interface & Harnesses

REF	PART #	DESCRIPTION	COMMENTS	QTY.
	052765	Cable Assembly, E430/EG400 PLC to Display Interface		1
	051311	Cable Assembly, Industrial Edger Left Cover Switch		1
	051312	Cable Assembly, Industrial Edger Center Cover Switch		1
	051313	Cable Assembly, Industrial Edger Right Cover Switch		1
	052744	Cable Assembly, Industrial Edger Perimeter Switch 2006		1
	052740	Cable Assembly, Industrial Edger Low Feed Proximity 2006		1
	052741	Cable Assembly, Industrial Edger Medium Feed Proximity 2006		1
	052745	Cable Assembly, Industrial Edger Reverse Switch 2006		1
	052746	Harness Assembly, Industrial Edger Blade Motor 2006		1
	051330	Harness Assembly, Industrial Edger Feed Motor		1
	051319	Harness Assembly, Industrial Edger Blade Position Motor		1

5.18 Frame Assembly

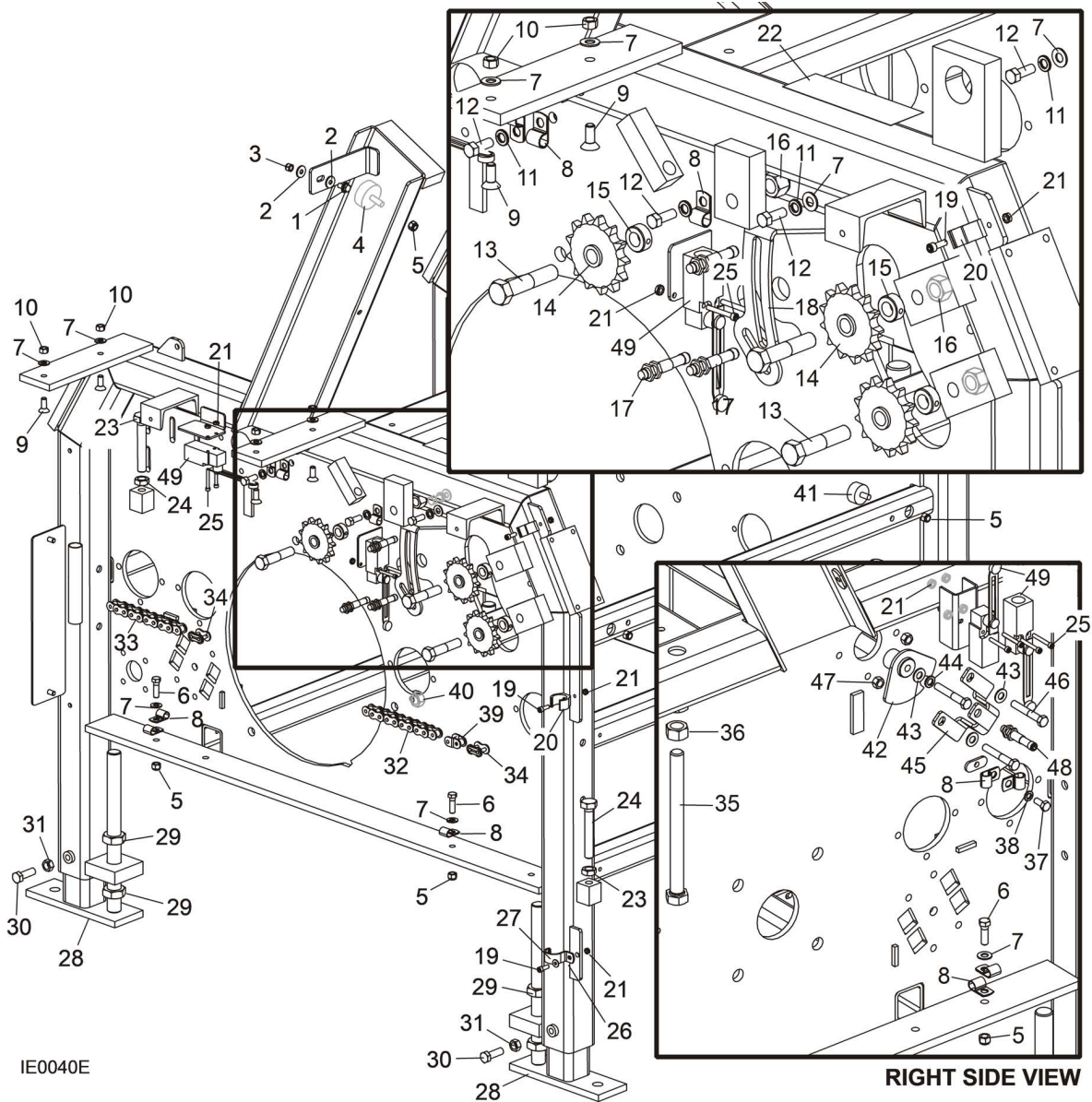

IE0040E

RIGHT SIDE VIEW

REF	PART #	DESCRIPTION	COMMENTS	QTY.
1	F05006-101	BOLT, 5/16-18 X 3/4" HEX HEAD W/WASHER		1
2	F05011-16	WASHER, 5/16" STANDARD FLAT		2
3	F05010-58	NUT, 5/16-18 NYLON LOCK		1
4	034175	BUMPER, TABLE		2
5	F05010-10	NUT, 3/8-16 HEX NYLON LOCK		5
6	F05007-2	BOLT, 3/8-16 X 1 1/4" HEX HEAD GRADE 2		3
7	F05011-3	WASHER, 3/8" FLAT		9
8	P07584	CLAMP, 1/2" EMT COATED		10
9	F05007-64	SCREW, 3/8-16 X 1" ZINC AND BAKE FS		4
10	F05010-25	NUT, 3/8-16 SWAGED		4
11	F05011-4	WASHER, 3/8" SPLIT		4
12	F05007-7	BOLT, 3/8-16 X 1" HEX HEAD		4
13	F05009-32	BOLT, 5/8-11 X 3" GRADE 2		3
14	034224	SPROCKET, 60BB13H X 5/8" IDLER		3
15	P05035	COLLAR, 5/8" ID LOCK		3

REF	PART #	DESCRIPTION	COMMENTS	QTY.
16	F05010-34	NUT, 5/8-11 NYLON LOCK		3
17	051439	SENSOR, IND PROXIMITY M12 PNP NS EX		3
18	039313	PLATE, PROXIMITY MOUNT		1
19	F05005-26	SCREW, 1/4-20 X 3/4" BO SOCKET HEAH CAP		3
20	038752	BRACKET, 3/4" FLEX MOUNTING		2
21	F05010-14	NUT, #10-24 KEPS		11
22	S20038	PLATE, SERIAL IDENTIFICATION		1
23	F05009-31	BOLT, 5/8-11 X 4" HEX HEAD FULL THREAD GRADE 5		3
24	F05010-82	NUT, 5/8-11 HEX JAM		3
25	F05004-51	BOLT, #10-24 X 1 1/2" SOCKET HEAD		8
26	F05011-18	WASHER, #10 SAE FLAT		1
27	P05436	CLAMP, 1" EMT		1
	039143	FOOT ASSEMBLY, EDGER		4
28	039115	Foot Weldment, Edger		1
29	F05010-118	Nut, 1-14 Hex Jam		2
30	F05008-33	BOLT, 1/2-13 X 1 1/2" HEX HEAD GRADE 5		4
31	F05010-35	NUT, 1/2-13 FREE HEX		4
32	039369	CHAIN, #60 X 135 3/4"		1
33	039368	CHAIN, #60 X 32 1/4"		1
34	042398	LINK, #60 CL		2
35	F05013-13	BOLT, 3/4-10 X 9" HEX HEAD FULL THREAD		1
36	F05010-7	NUT, 3/4-10 FREE HEX		1
37	F05006-5	BOLT, 5/16-18 X 3/4" HEX HEAD GRADE 2		1
38	F05011-13	WASHER, 5/16" SPLIT LOCK		1
39	036683	LINK, #60 HALF		1
40	F05010-54	NUT, 5/8-11 UNPLATED HEX		2
41	038138	BUMPER, 1 1/2" X 5/8" URETHANE		4
	038722	PROXIMITY ASSEMBLY, E430/EG400 BOARD SENSING		1
42	038715	Activator Weldment, Outfeed Sensor		1
43	F05011-3	Washer, 3/8" Flat SAE		3
44	F05011-4	Washer, 3/8" Split Lock		1
45	038710	Bracket, Outfeed Proximity Mount		1
46	F05007-125	Bolt, 3/8-16 x 2 1/2" Hex Head Grade 5		3
47	F05010-25	Nut, 3/8-16 Swagged Lock		2
48	051439	Sensor, Ind Proximity M12 PNP NS Ex		1
49	039378	SWITCH, SAFETY LIMIT		4

5.19 Housing Covers & Control Assembly

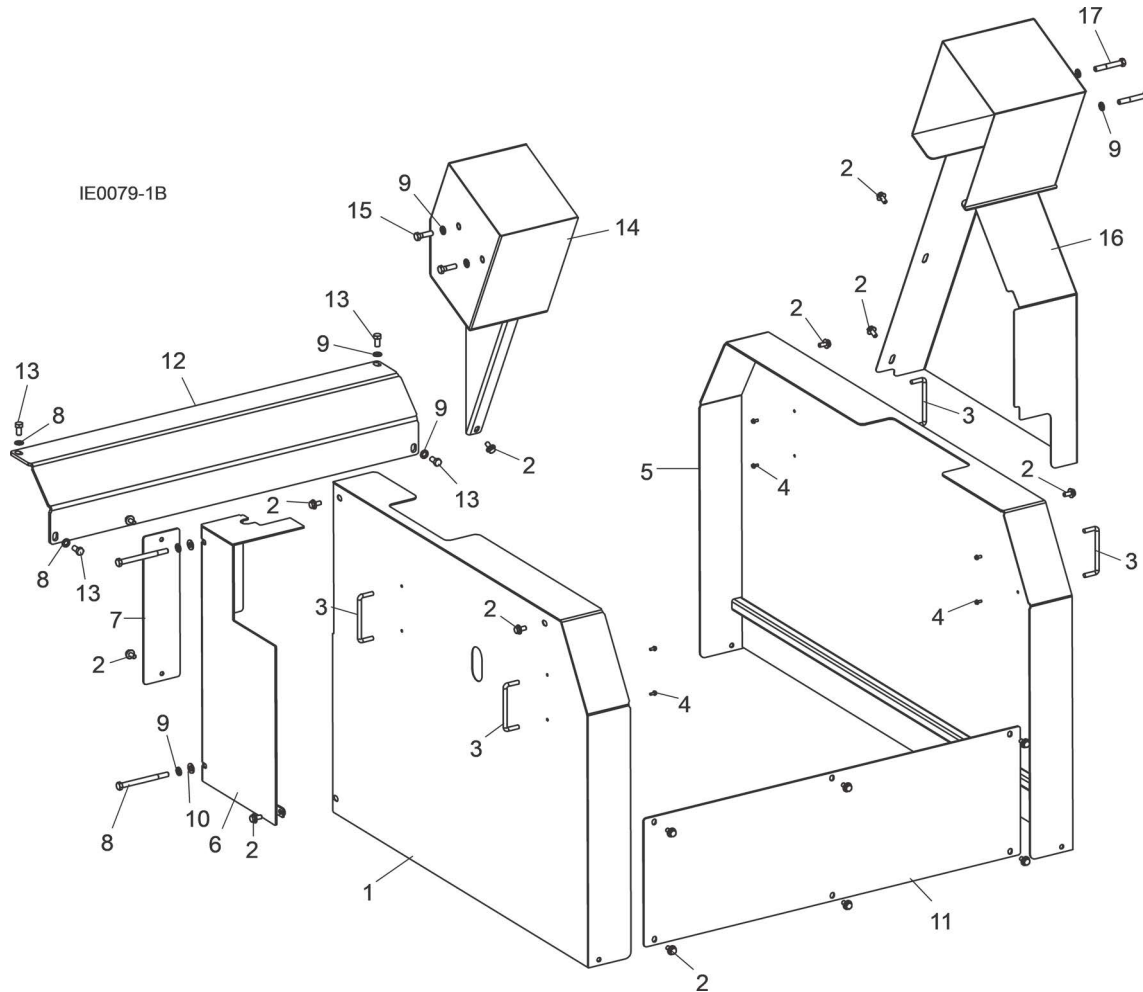

REF	PART #	DESCRIPTION	COMMENTS	QTY.
1	039220	GUARD, FEED DRIVE SIDE REMOVABLE		1
2	F05006-101	BOLT, 5/16-18 X 3/4" HEX HEAD W/WASHER		15
3	P08065	HANDLE, 4" W/BOLT		4
4	F05015-8	SCREW, #8-32 X 3/8" SELF TAP		8
5	039219	GUARD WELDMENT, BLADE DRIVE SIDE		1
6	003315	GUARD WELDMENT, FEED SIDE		1
7	003306	COVER, TAILER DRIVE ACCESS		1
8	F05007-35	BOLT, 3/8-16 X 4 1/2" HEX HEAD		2
9	F05011-4	WASHER, 3/8" SPLIT		10
10	F05011-3	WASHER, 3/8" SAE FLAT		2
11	039296	GUARD, LOWER FRONT		1
12	039210	PLATE, DRIVE GUARD		1
13	F05007-27	BOLT, 3/8-16 X 3/4 HEX HEAD		4
14	039228	GUARD WELDMENT. ELEC BOX SIDE TOP		1
15	F05007-123	BOLT, 3/8-16 X 1 1/4" HEX HEAD GR5		2
16	039229	GUARD WELDMENT, MOTOR SHEAVE		1
17	F05007-125	BOLT, 3/8-16 X 2 1/2" HEX HEAD GR5		2

5.20 Top Blade Guard Assembly

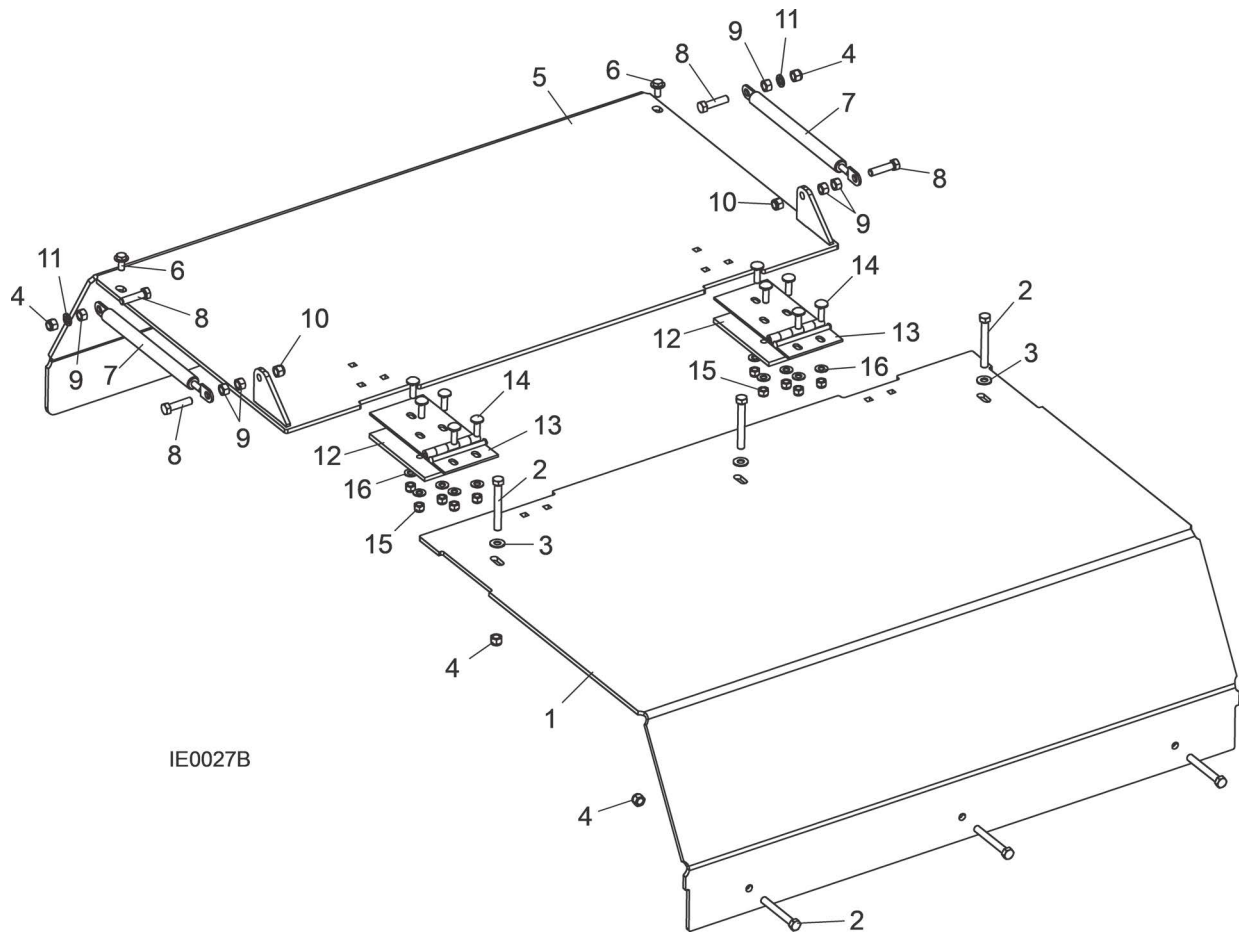

IE0027B

REF	PART #	DESCRIPTION	COMMENTS	QTY.
	039273	GUARD ASSEMBLY, TOP BLADE		1
1	039020	Plate, Top Front Cover		1
2	F05007-1	Bolt, 3/8-16 x 3 Hex Head Full Thread		6
3	F05011-3	Washer, 3/8 Flat		3
4	F05010-10	Nut, 3/8-16 Hex Nylon Lock		8
5	039272	Guard Weldment, Rear Blade		1
6	F05006-101	Bolt, 5/16-18 x 3/4 Hex Head W/Washer		2
7	P22309	Spring, Perimeter Fence Gas		2
8	F05007-17	Bolt, 3/8-16 x 1 1/2 Hex Head Full Thread		4
9	F05010-1	Nut, 3/8-16 Hex		6
10	F05010-25	Nut, 3/8-16 Swaged		2
11	F05011-4	Washer, 3/8 Split		2
12	039314	Plate, Hinge Stiffener		2
13	038136	Hinge, 2 x 5.5 x 3.5 x .125, w/Slots		2
14	F05006-9	Bolt, 5/16-18 x 1 Carriage		10
15	F05010-58	Nut, 5/16-18 Nylon Lock		10
16	F05011-17	Washer, 5/16 SAE Flat		10

5.21 Decals

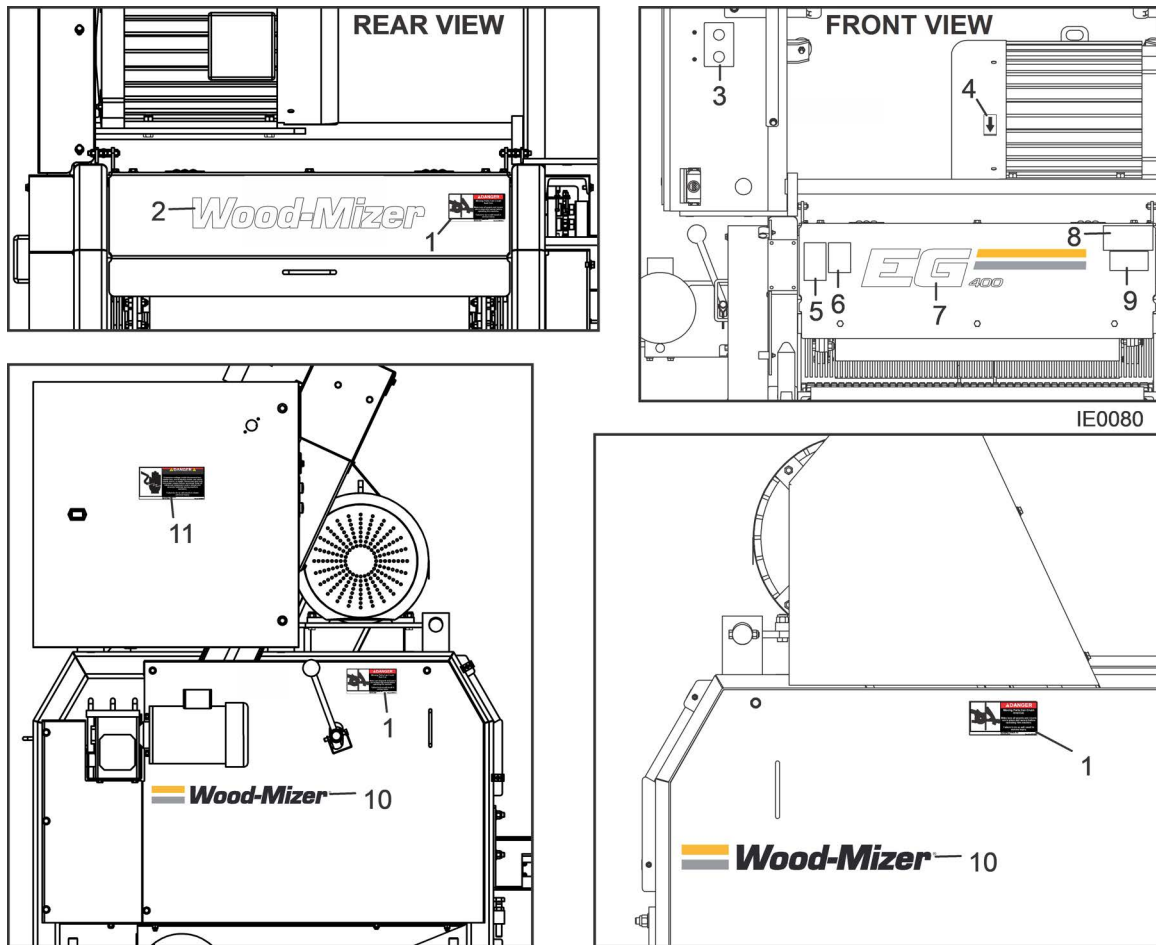

REF	PART #	DESCRIPTION	COMMENTS	QTY.
1	033254	DECAL, MOVING PARTS DANGER		2
2	065034	DECAL, WOOD-MIZER LOGO 20.5" WHITE		1
3	052289	DECAL, E430/EG400 STATUS LIGHT		1
4	S20097	DECAL, MOTOR DIRECTION		1
5	038176	DECAL, BLADE HAZARD DANGER		1
6	S11753	DECAL, EYE/EAR PROTECTION WARNING		1
7	076279	DECAL, EG400 LOGO		1
8	016402	DECAL, READ MANUAL WARNING		1
9	038134	DECAL, KICKBACK HAZARD WARNING		1
10	076273	DECAL, WOOD-MIZER LOGO WITH STRIPES		2
11	S20061	DECAL, ELECTRICAL HAZARD DANGER		1

5.22 Chute Assembly

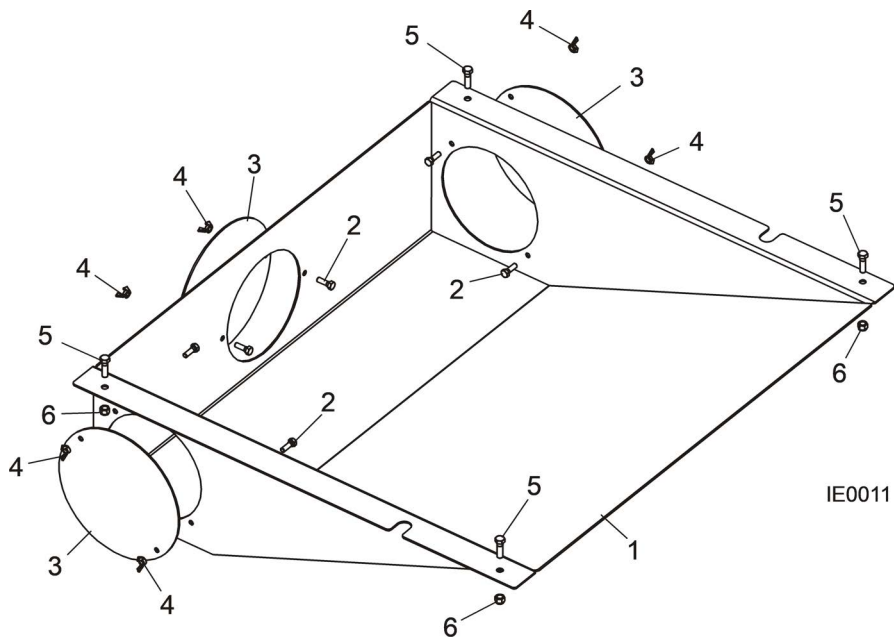

REF	PART #	DESCRIPTION	COMMENTS	QTY.
	039290	CHUTE ASSEMBLY, INDUSTRIAL EDGER		1
1	039289	Hopper Weldment, Industrial Edger		1
2	F05006-1	Bolt, 5/16-18 x 1 Hex Head Gr2		6
3	039288	Cover, Hopper Hole		3
4	F05010-23	Nut, 5/16-18 Wing		6
5	F05007-123	Bolt, 3/8-16 x 1 1/4 Hex Head Gr5		4
6	F05010-10	Nut, 3/8-16 Hex Nylon Lock		4

5.23 Networks Retrofit (Optional)

REF	PART #	DESCRIPTION	COMMENTS	QTY.
	E4SET-A	NETWORKS RETROFIT, E430/EG400 (FIELD INSTALLED)		1
1		Transducer Cover Parts (See Section 5.26)		
2		Transducer Parts (See Section 5.25)		
3		LED Display Parts (See Section 5.24)		
4		Wireless Remote Parts (See Section 5.28)		
5		Add-On Control Switch Parts (See Section 5.27)		
6	E4REM-1271	Instruction Sheet, E430/EG400 Remote Option		1
7	E4SET-1270	Instruction Sheet, E430/EG400 Networks Option		1

5.24 Display Assembly (Optional)

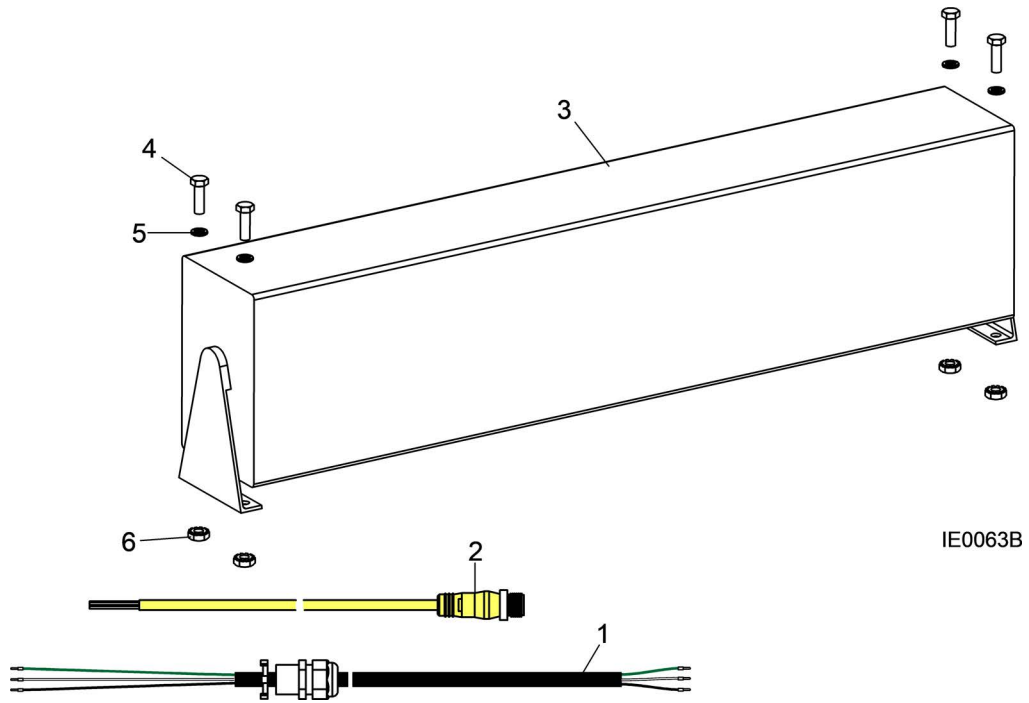

REF	PART #	DESCRIPTION	COMMENTS	QTY.
	038764	DISPLAY ASSEMBLY, LED 10" CHARACTER		1
1	052780	Cable Assembly, E430/EG400 Display Power		1
2	052784	Cable Assembly, E430/EG400 Display to Box		1
3	038762	Display, 2" x 10" Character LED		1
4	F05004-18	Screw, 10-24 x 5/8" Hex Head		4
5	F05011-20	Washer, #10 Split Lock		4
6	F05010-14	Nut, #10-24 Keps		4

5.25 Transducer Assembly (Optional)

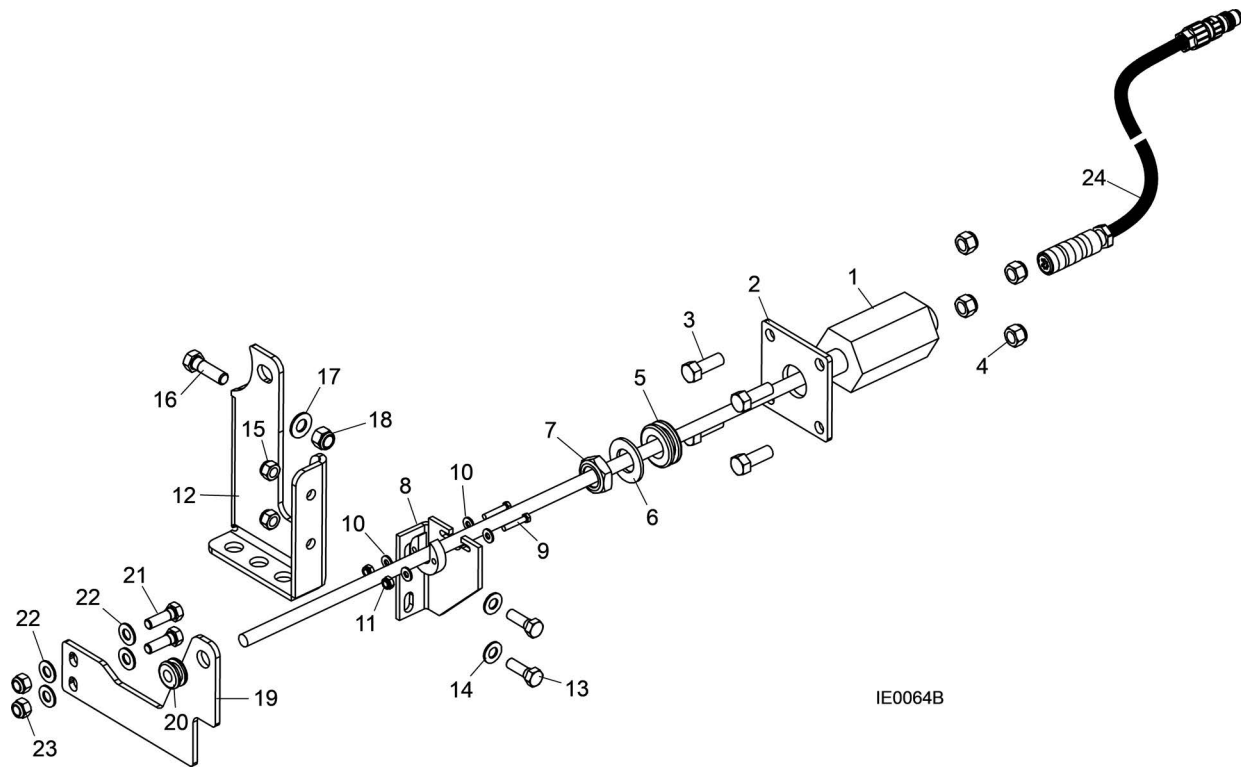

REF	PART #	DESCRIPTION	COMMENTS	QTY.
	038701	TRANSDUCER ASSEMBLY, E430/EG400 EDGER		1
1	038694	Transducer, Position 20"		1
2	038689	Plate, Linear Sensor Mount		1
3	F05007-7	Bolt, 3/8-16 x 1" Hex Head		4
4	F05010-10	Nut, 3/8-16 Hex Nylon Lock		4
5	025247	Grommet, 3/4" ID Rubber		1
6	025250	Washer, 3/4" ID Nylon		1
7	F05010-171	Nut, 3/4-16 Nylon Lock		1
8	038695	Plate, E430/EG400 Transducer Ring Mount		1
9	F05004-182	Screw, #8-32 x 7/8" Hex Head Stainless Steel		2
10	F05011-41	Washer, #8 Sae Flat		4
11	F05010-169	Nut, #8-32 Hex Nylon Lock		2
12	038688	Bracket, Pusher Magnet Mount		1
13	F05006-1	Bolt, 5/16-18 x 1" Hex Head Grade 2		2
14	F05011-17	Washer, 5/16" SAE Flat		2
15	F05010-58	Nut, 5/16-18 Nylon Lock		2
16	F05007-123	Bolt, 3/8-16 x 1 1/4" Hex Head Grade 5		1
17	F05011-3	Washer, 3/8" SAE Flat		1
18	F05010-10	Nut, 3/8-16 Hex Nylon Lock		1
19	038700	Bracket, 7Ga Rod End		1
20	025248	Grommet, Rubber 3/8" ID		1
21	F05006-1	Bolt, 5/16-18 x 1" Hex Head Grade 2		2
22	F05011-17	Washer, 5/16" SAE Flat		4
23	F05010-58	Nut, 5/16-18 Nylon Lock		2
24	052781	Cable Assembly, E430/EG400 Transducer		1

5.26 Transducer Cover Assembly (Optional)

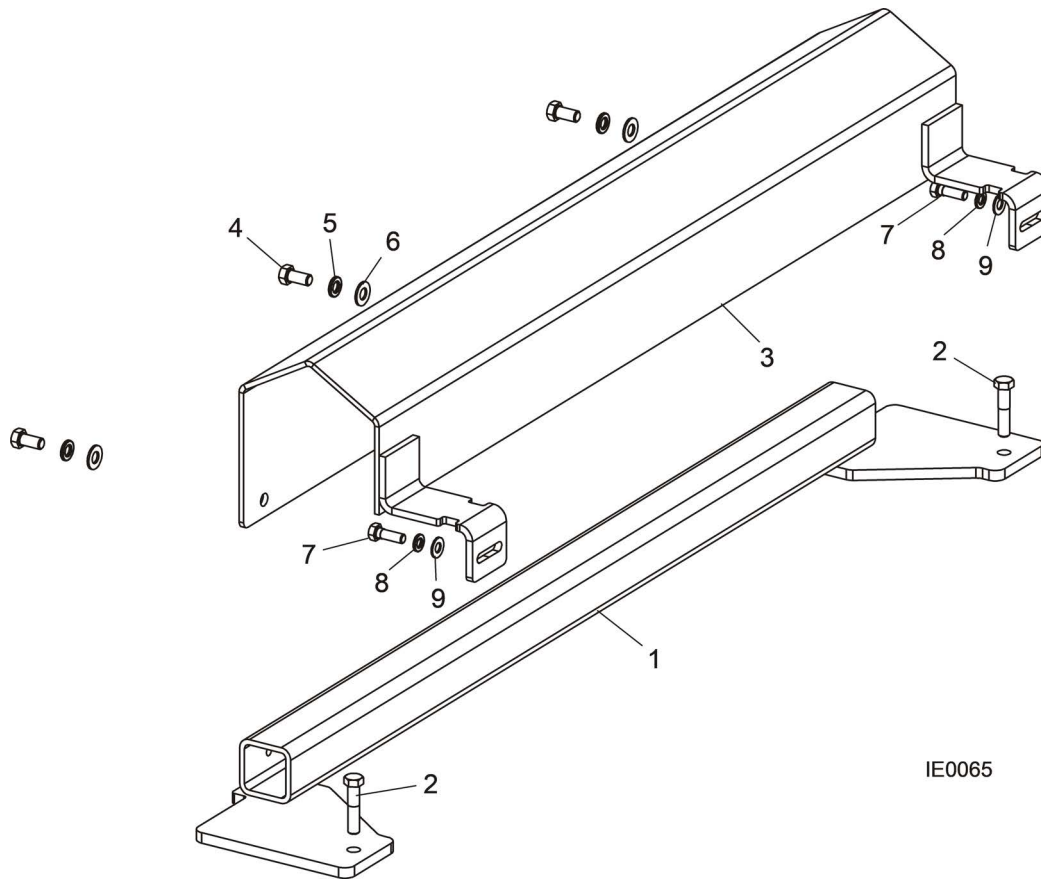

REF	PART #	DESCRIPTION	COMMENTS	QTY.
	038718	COVER ASSEMBLY, E430/EG400 EDGER TRANSDUCER		1
1	038706	Tube Weldment, E430/EG400 Cross Cover		1
2	F05007-119	Bolt, 3/8-16 x 1 3/4" Grade 5		2
3	038707	Guard Weldment, E430/EG400 Transducer		1
4	F05007-118	Bolt, 3/8-16 x 3/4" Hex Head Grade 5		3
5	F05011-4	Washer, 3/8" Split Lock		3
6	F05011-3	Washer, 3/8" Flat SAE		3
7	F05006-1	Bolt, 5/16-18 x 1" Hex Head Grade 2		2
8	F05011-13	Washer, 5/16" Split Lock		2
9	F05011-17	Washer, 5/16" SAE Flat		2

5.27 Networks Switch Assembly (Optional)

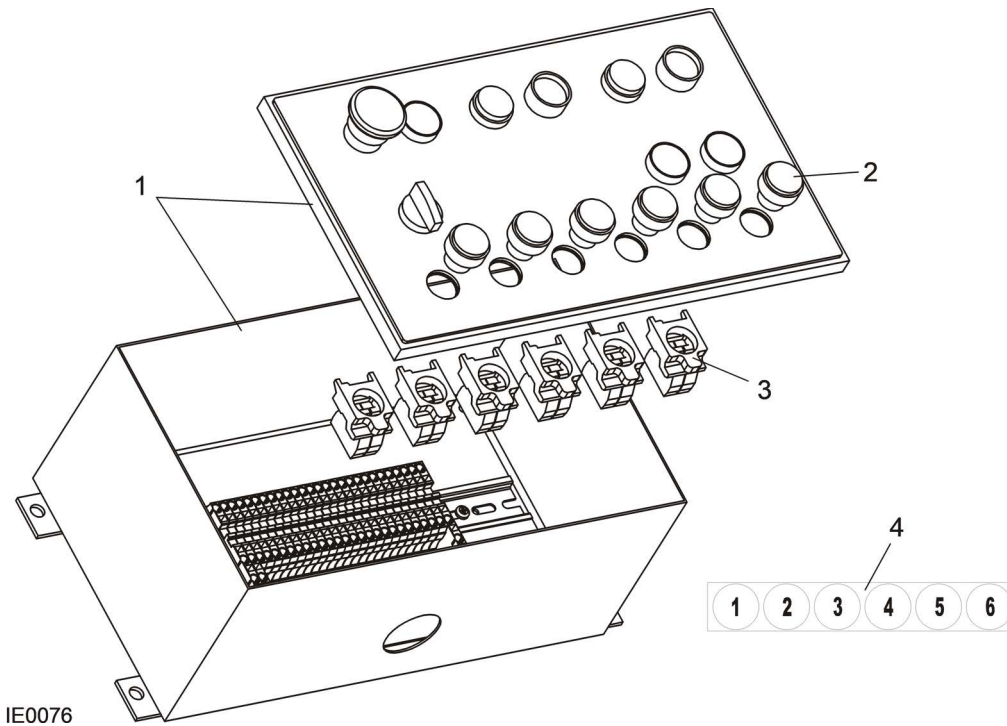

REF	PART #	DESCRIPTION	COMMENTS	QTY.
1		CONTROL ASSEMBLY, OPERATOR (See Section 5.15)		
	052819	SWITCH KIT, E430/EG400 NETWORKS (FIELD INSTALLED)		1
2	025237-68	Switch Head, 22mm Mom Flush LED Blue XB4		6
3	025236-61	Switch Body, 22mm Blue LED 1 NO 24V XB4		6
4	052822	Label Set, E430/EG400 Networks Preset		1

5.28 Remote Assembly (Optional)



IE0075

REF	PART #	DESCRIPTION	COMMENTS	QTY.
	E4REM	REMOTE ASSEMBLY, E430/EG400 BLADE POSITION WIRELESS		1
1	052798	Transmitter, 6-Button Remote		1
	052800	Receiver Assembly, 6-Function w/Connector		1
	F05005-128	Screw, 1/4-20 x 5/8" Socket Cap Stainless Steel		4
	052801	Antenna Kit, 2-Foot Extension		1
	F05011-19	Washer, 5/8 x 15/16 x .094 Nylon		1

SECTION 6 ELECTRICAL INFORMATION

6.1 Electrical Symbol Diagram

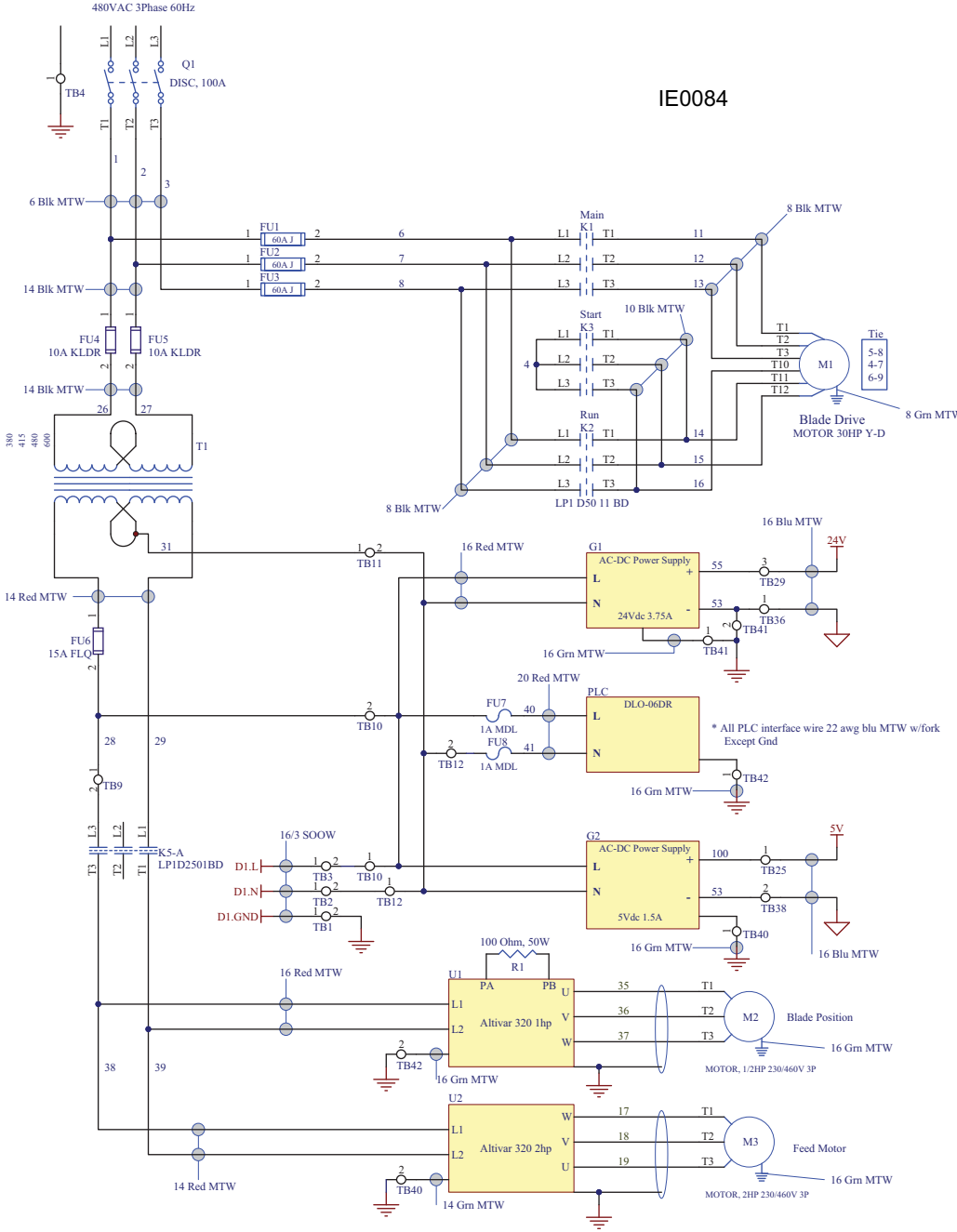

FIG. 6-1 SYMBOL DIAGRAM (1 OF 6)

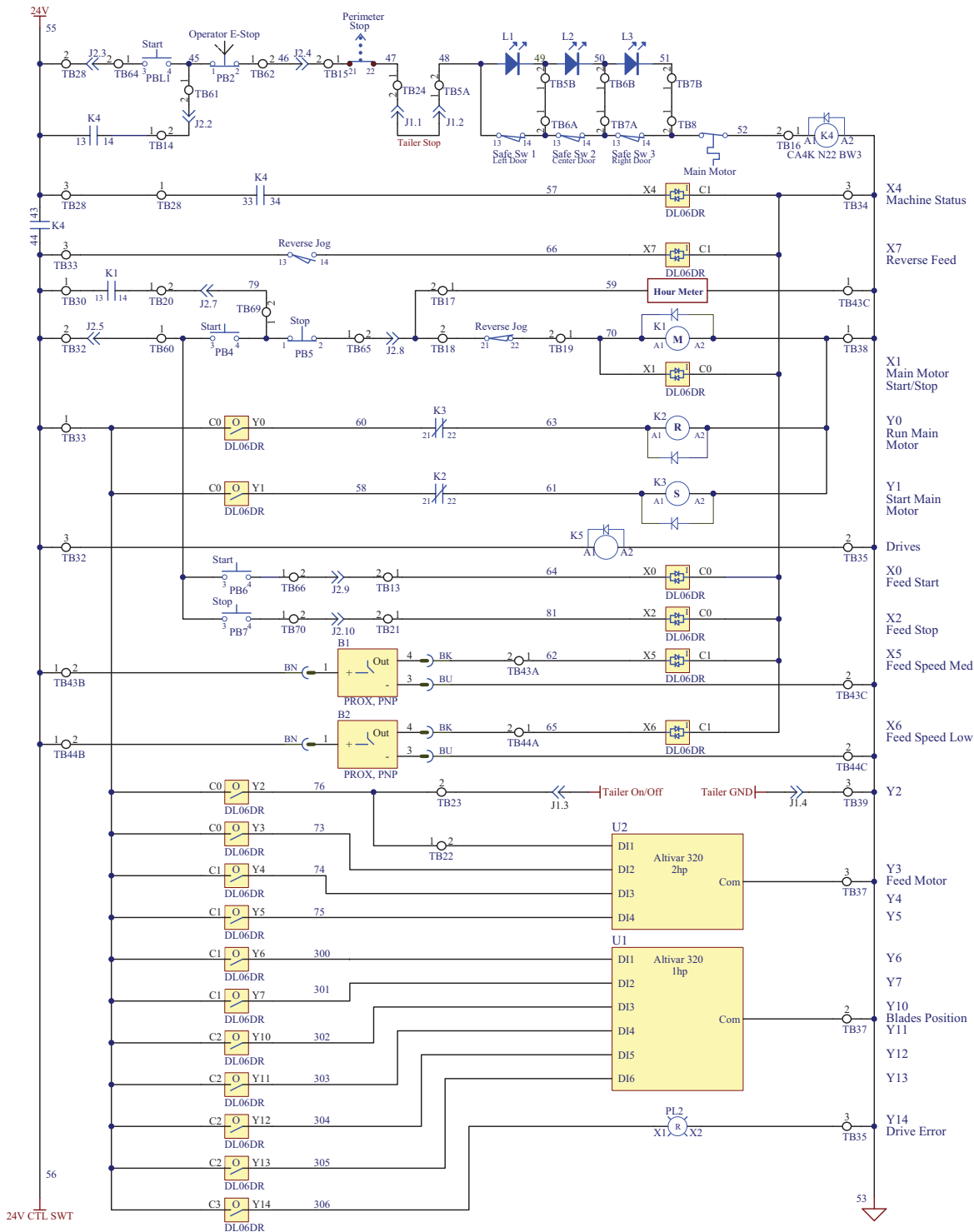

FIG. 6-1 SYMBOL DIAGRAM (2 OF 6)

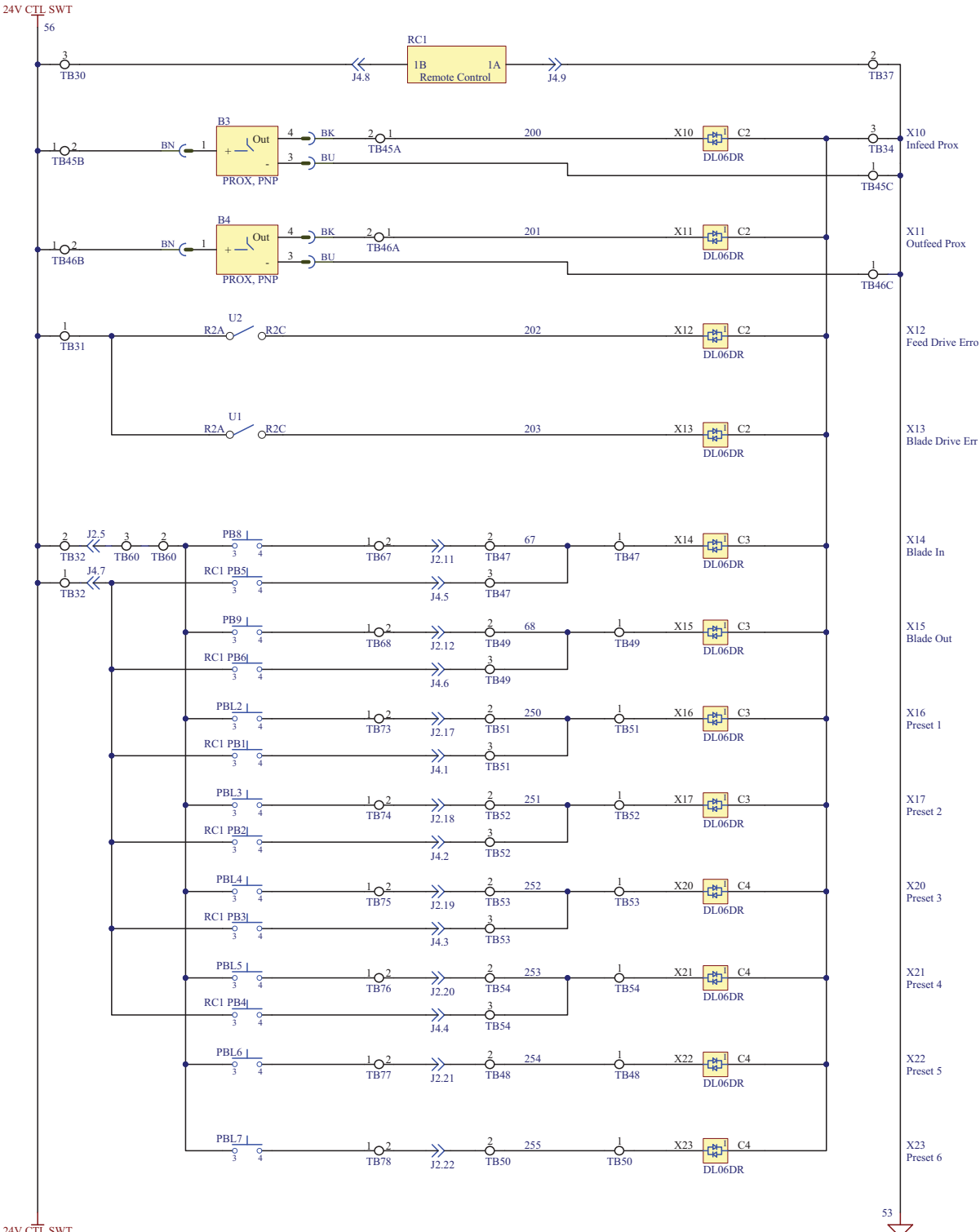

FIG. 6-1 (3 OF 6)

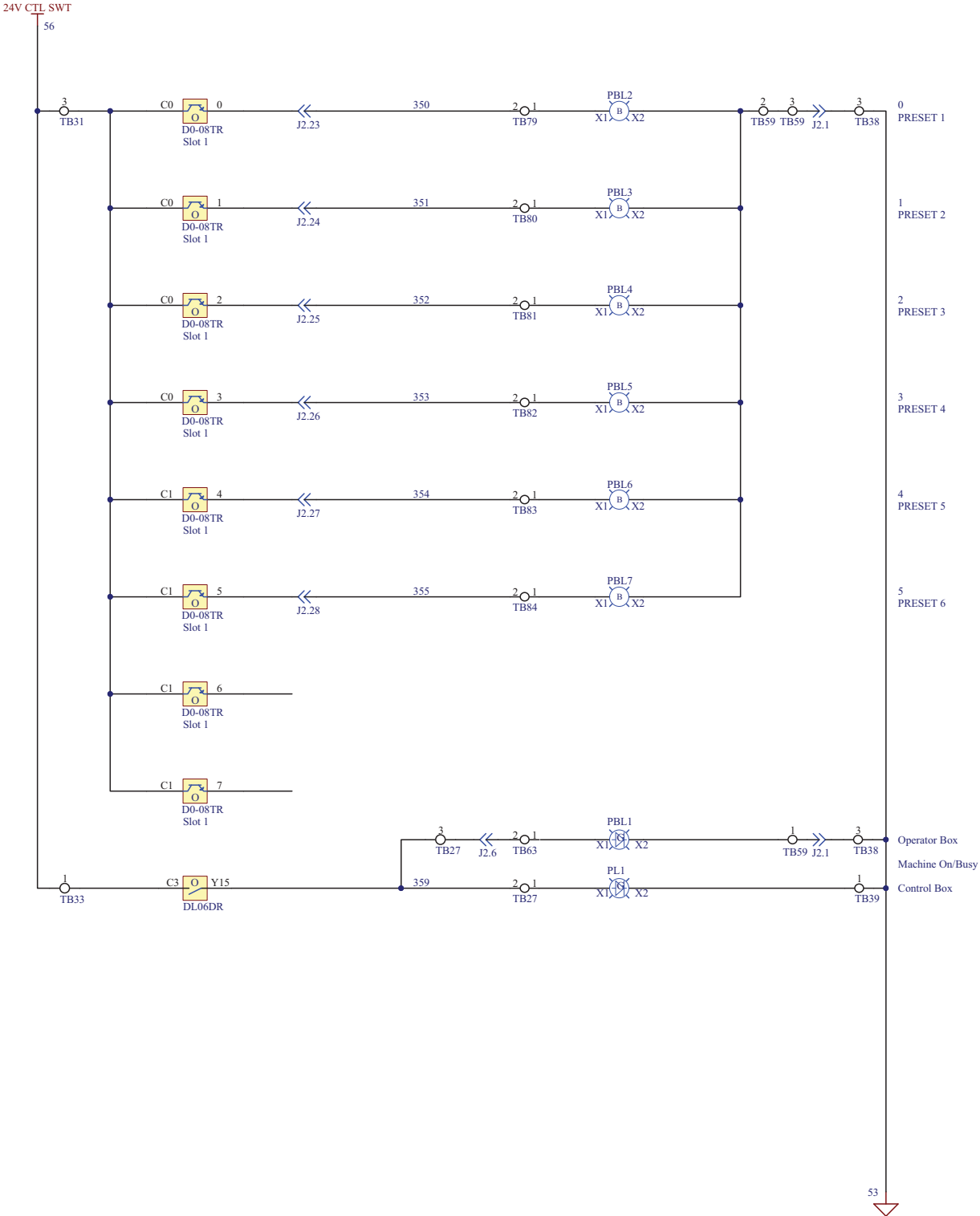
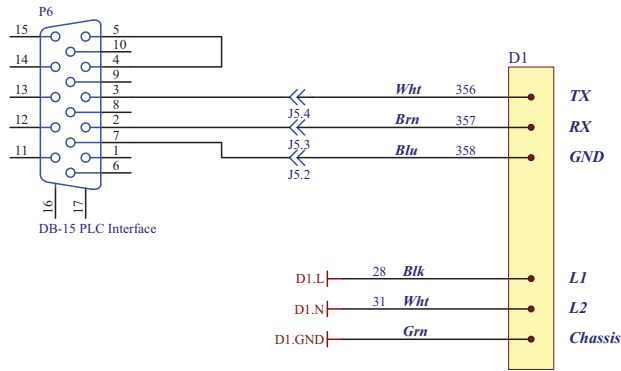
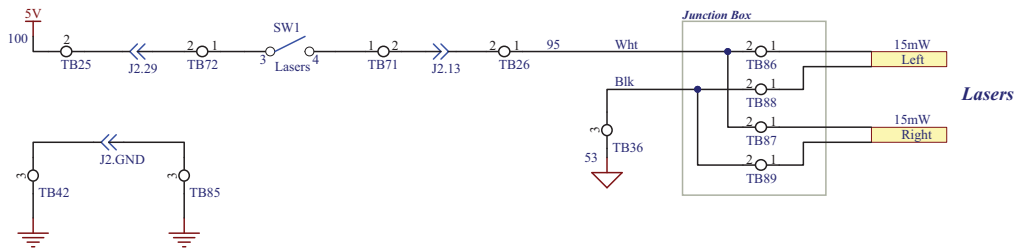

FIG. 6-1 (5 OF 6)



Interface Cable (J2)

Pin #	Wire #
1 - Black #1	53
2 - Black #2	45
3 - Black #3	55
4 - Black #4	46
5 - Black #5	56
6 - Black #6	359
7 - Black #7	79
8 - Black #8	59
9 - Black #9	64
10 - Black #10	81
11 - Black #11	67
12 - Black #12	68
13 - Black #13	95
14 - _____	
15 - _____	
16 - _____	
17 - Black #17	250
18 - Black #18	251
19 - Black #19	252
20 - Black #20	253
21 - Black #21	254
22 - Black #22	255
23 - Black #23	350
24 - Black #24	351
25 - Black #25	352
26 - Black #26	353
27 - Black #27	354
28 - Black #28	355
29 - Black #29	100
30 - _____	
31 - _____	
32 - _____	

FIG. 6-1 (6 OF 6)

6.2 Electrical Component List

Component	Wood-Mizer Part No.	Description
FU1, FU2, FU3	052733	Fuse, 600V 60A Class J
FU4, FU5	052757	Fuse, 10A 600V KLDR Class CC
FU6	052758	Fuse, 15A 600V Time Delay Midget
FU7, FU8	P03042	Fuse, MDL 1 Amp Glass
G1	052633	Power Supply, 110/230VAC 24VDC 3.75A
G2	052755	Power Supply, 110/230VAC 5VDC 1.5A
H1	015401	Hour Meter, 12 Volt DC
K1, K2	053601	Contactora, 50A 3P 24VDC D-A Series
K3, K5	051322	Contactora, Industrial Edger
K4	024809	Relay, IEC 3NO 1NC 3A 24VDC Control
M1	042301	Motor, 30HP 1800RPM Blade Drive
M2	039274	Motor, 1/2HP 1725RPM Blade Position
M3	042390	Motor, 2HP 3PH 230/460V TEFC 56C No Base
PB2	024945	Switch Head, Red Push Button 22mm XB4
	025161	Switch Body, 22mm 1NC XB4
PB4, PB6	050152	Switch Head, Green Guarded
	025242	Switch Body, 22mm 1NO XB4
PB5	050151	Switch Head, Red Extended
	025161	Switch Body, 22mm 1NC XB4
PB7	050151	Switch Head, Red Extended
	025242	Switch Body, 22mm 1NO XB4
PB8, PB9	050197	Switch Head, 22mm Mom Flush Blue XB4
	025242	Switch Body, 22mm 1NO XB4
PBL1	051301	Switch Head, Green Flush ZB4
	025236-31	Switch Body, 22mm Green LED 1NO 24V XB4
PBL2-PBL7	025237-68	Switch Head, 22mm Mom Flush LED Blu XB4
	025236-61	Switch Body, 22mm Blu LED 1 NO 24V ZB4
PL1	024970-3	Light, Green 24V 22mm LED XB4 Pilot
PL2	024970-4	Light, Red 24V 22mm LED XB4 Pilot
PLC	052753	PLC Assembly, E430 (Programmed w/Modules)
	069356	PLC Assembly, E430 2006 (Programmed)
	050163	PLC Module, 4 CH Analog Input 4-20MA
	052754	PLC Module, D06 8P Relay Out
Q1	050906-1	Disconnect, 100A 3Phase Non-Fused 6mm
	050907-1	Operator, Red/Yellow Pistol Grip Disconnect 6mm
	050908-1	Shaft, Disconnect Operator Extension 6mm
R1	052764	Resistor Assembly, 50W 100 Ohm
Reverse Jog, SAFE SW1-SW3	039378	Switch, Safety Limit
SW1	051302	Switch Head, 2 Pos. Maint. ZB4
	025242	Switch Body, 22mm 1NO XB4
T1	052756	Transformer, 2KVA 460V - 230V
TB1	051344	Terminal Block, Green/Yellow Grounding
TB2	024893	Terminal Block, 1 Tier Gray
TB3	051308	Terminal Block, 1 Tier Black
TB4	050887	Terminal Block, 1 Tier Ground

6 Electrical Information

Electrical Component List

TB5-7	051324-1	Terminal Block, 2 Tier w/LED
TB8-TB26, TB61-84, TB86-TB89	052750	Terminal Block, 2P Gray Cage Clamp
TB27-39, TB47-54, TB59-60	052760	Terminal Block, 3P Gray Cage Clamp
TB40, TB42 TB85	052752	Terminal Block, Green/Yellow GND 3P
TB43-TB46	052759	Terminal Block, 3 Tier Cage Clamp
U1	052173	Drive Assembly, IE Blade Position Motor 2005
U2	052174	Drive Assembly, IE Feed Motor 2005

6.3 Component Layout Diagrams

Control Cabinet/Laser Interface

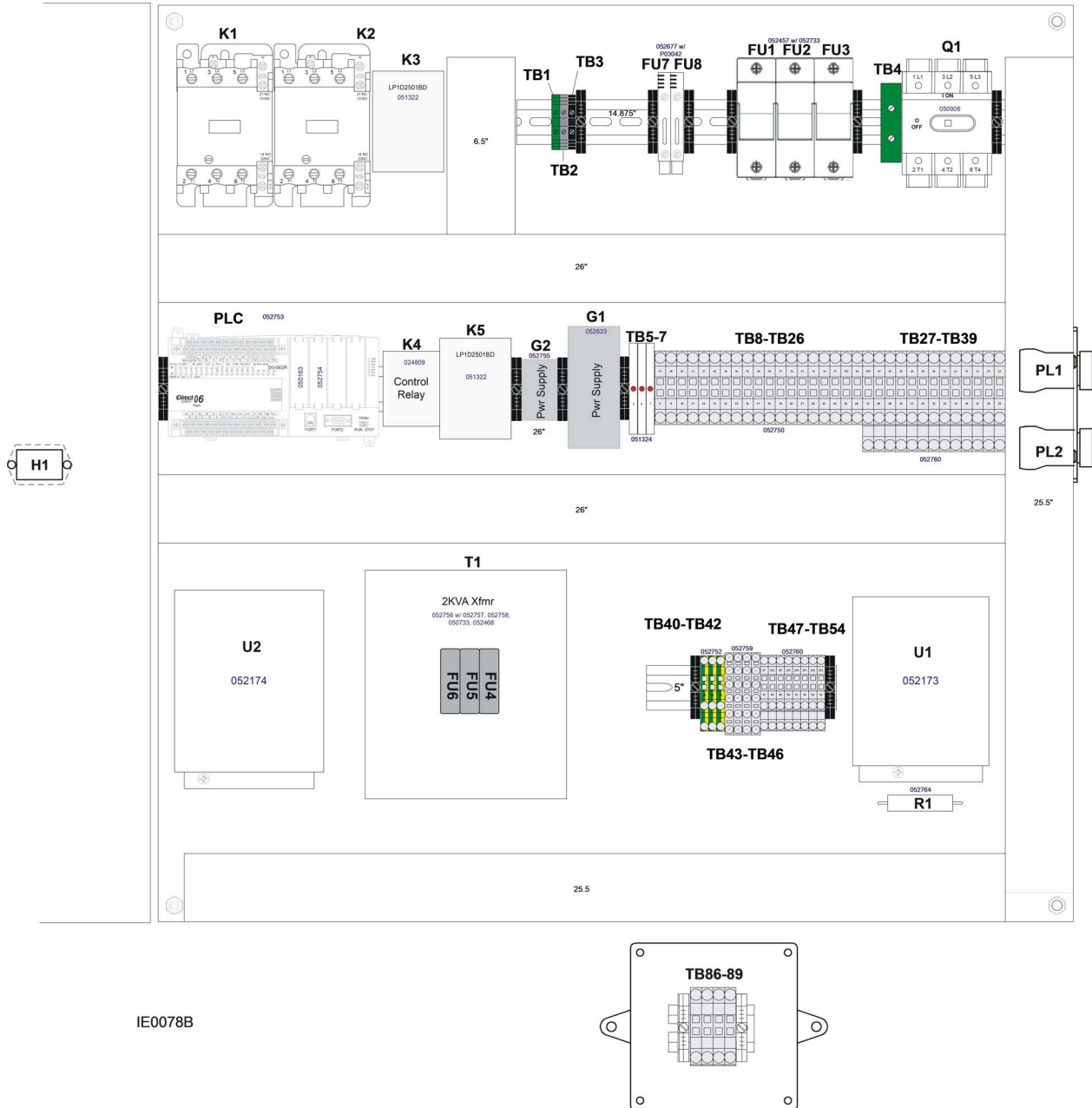

FIG. 6-1

Operator Interface without Networks

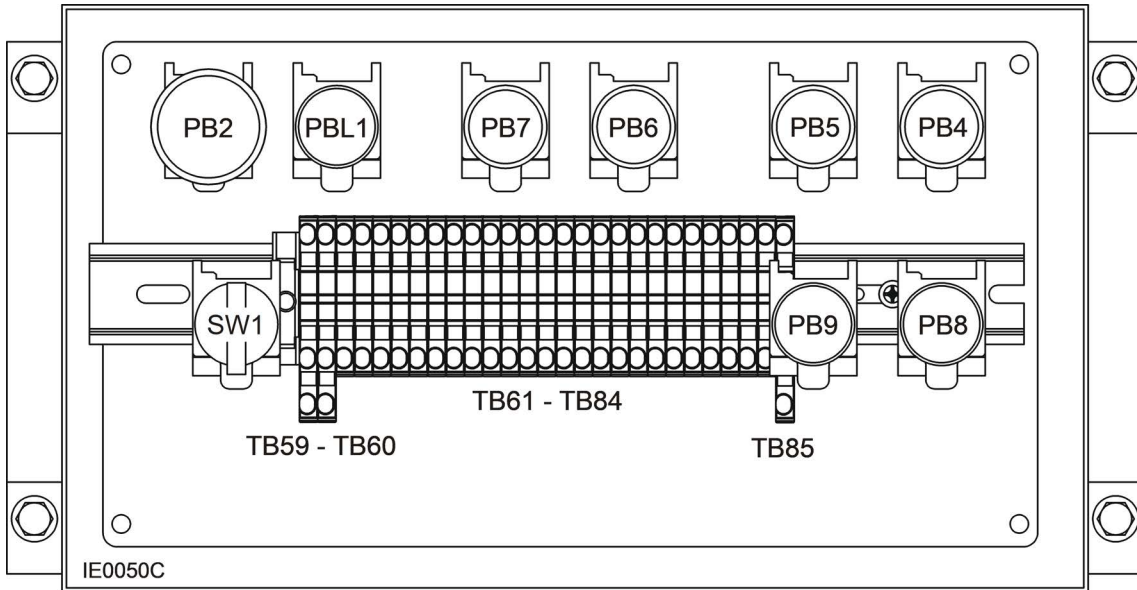

FIG. 6-1

Operator Interface with Networks

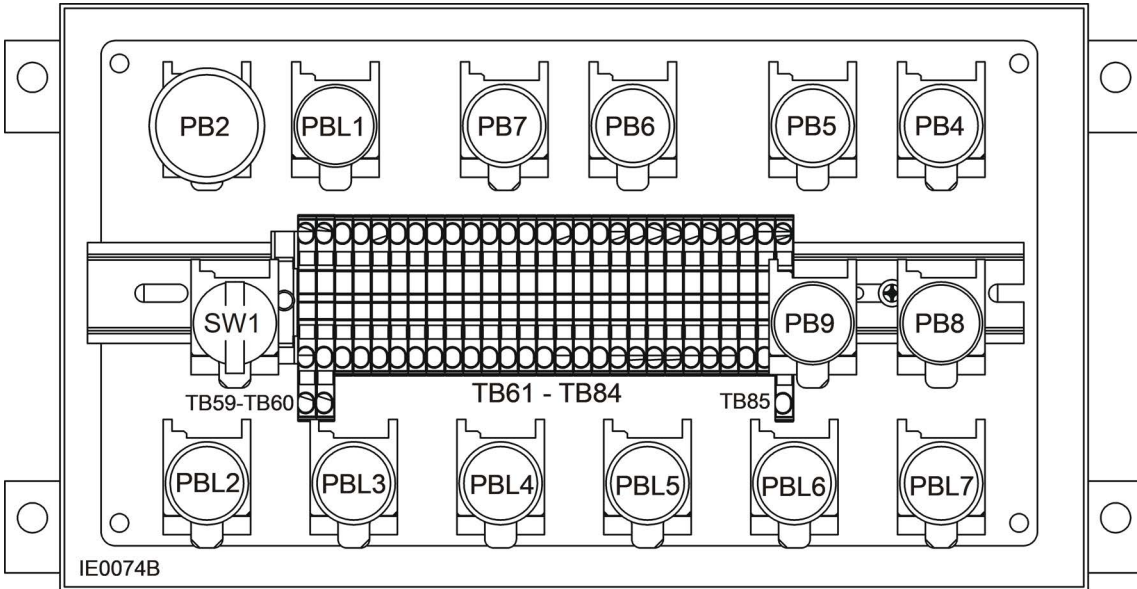

FIG. 6-1

INDEX

E

electrical information 6-1
 component layout diagrams 6-9
 component list 6-7
 symbol diagram 6-1

I

introduction
 dimensions 1-2

M

maintenance
 anti-kickback fingers 4-11
 changing blades 4-1
 feed rate adjustment 4-10
 laser guides alignment 4-12
 replacing blade teeth 4-1
 tensioning belts 4-4
 tensioning chains 4-7

O

operation & setup
 edging lumber 3-12
 electrical installation 3-3
 pre-operation checks 3-8
 remote operation (optional) 3-16
 setup 3-1
 setworks (optional) 3-14
 starting the machine 3-10

R

replacement parts
 blade and laser drives 5-5
 blades 5-11
 blades motor 5-14
 blades shaft 5-13
 chute 5-33
 display (optional) 5-35
 electrical control cabinet 5-26
 electrical harnesses 5-26
 feed drive 5-15
 frame 5-28
 housing covers 5-30, 5-32
 infeed table assembly 5-3
 kickback 5-21
 laser guides 5-10
 laser guides housing 5-8
 laser motor drive 5-7
 lower drive roller 5-18
 operator control 5-22
 operator control (w/optional setworks) 5-24
 remote (optional) 5-39
 setworks retrofit (optional) 5-34
 setworks switches (optional) 5-38
 tensioner 5-20
 top blade guard 5-31
 transducer (optional) 5-36
 transducer cover (optional) 5-37
 upper driven roller 5-17
 upper idle roller 5-19

S

safety
 instructions 2-4
 lockout procedure 2-7

Safety Symbols 1-1