

Dual Toothsetter

Safety, Operation, Maintenance, & Parts Manual

BMT200	rev. A1.03
BMT250	rev. A1.02

Safety is our #1 concern!

Form #1792

MODELS AFFECTED

BMT200
BMT250AS
BMT250MU (OBS)
BMT250MUD



WARNING! Read and understand this manual before using this machine.

California

Proposition 65 Warning



WARNING: Breathing gas/diesel engine exhaust exposes you to chemicals known to the State of California to cause cancer and birth defects or other reproductive harm.

Always start and operate the engine in a well-ventilated area.
If in an enclosed area, vent the exhaust to the outside.
Do not modify or tamper with the exhaust system.
Do not idle the engine except as necessary.

For more information go to www.P65warnings.ca.gov.



WARNING: Drilling, sawing, sanding or machining wood products can expose you to wood dust, a substance known to the State of California to cause cancer. Avoid inhaling wood dust or use a dust mask or other safeguards for personal protection.

For more information go to www.P65Warnings.ca.gov/wood.

Active Patents assigned to Wood-Mizer, LLC

Wood-Mizer, LLC has received patents that protect our inventions which are a result of a dedication to research, innovation, development, and design. Learn more at: woodmizer.com/patents

©December 11, 2023 Wood-Mizer LLC

Printed in the United States of America, all rights reserved. No part of this manual may be reproduced in any form by any photographic, electronic, mechanical or other means or used in any information storage and retrieval system without written permission from

Wood-Mizer, LLC
8180 West 10th Street
Indianapolis, Indiana 46214

SECTION 1 INTRODUCTION

1.1 About This Manual 1-1
 1.2 Getting Service..... 1-1
 1.3 Specifications 1-1
 1.4 Dimensions and Specifications 1-1

SECTION 2 GENERAL SAFETY

2.1 Safety Symbols 2-1
 2.2 Safety Instructions..... 2-1
 Observe ALL Safety Instructions..... 2-1
 2.3 Electrical Lockout Procedures 2-1

SECTION 3 SETUP & OPERATION

3.1 Assembly..... 3-1
 Blade Support Arms 3-1
 Auto Feed Installation (Optional - AC Only)..... 3-1
 Auto Feed Installation (Optional - DC Only) 3-2
 3.2 Dual Setter Calibration..... 3-5
 Tooth Set Master Gauge Calibration..... 3-5
 Dual Setter Calibration..... 3-5
 3.3 Operation..... 3-7
 Blade Installation/Setup..... 3-7
 Manual Feed Operation..... 3-10
 Auto Feed Operation..... 3-10

SECTION 4 MAINTENANCE

4.1 Routine Maintenance Schedule..... 4-1
 Every 2 Weeks 4-1
 Every 3 Months..... 4-1
 Clamp Adjustment 4-1
 Gauge Assembly Adjustment 4-1
 4.2 Safety Devices Inspection..... 4-2

SECTION 5 REPLACEMENT PARTS

5.1 Dual Toothsetter (Complete) 5-1
 5.2 Dual Toothsetter Assembly..... 5-2
 5.3 Base Housing Assembly 5-3
 5.4 Feed Drive Assembly..... 5-5
 5.5 Blade Setters 5-7
 5.6 Blade Set Arm Assembly 5-9
 5.7 Clamp Assembly 5-11
 5.8 Index Assembly..... 5-13
 5.9 Blade Support Arm Assembly 5-15
 5.10 Auto Feed Control, AC 120V (Optional)..... 5-17
 5.11 Auto Feed Control, AC 220V (Optional)..... 5-19
 5.12 Auto Feed Control, DC (Optional) 5-21
 5.13 Auto Feed Control Panel, AC (Optional)..... 5-23
 5.14 Auto Feed Motor, AC (Optional)..... 5-24
 5.15 Auto Feed Motor, DC (Optional)..... 5-25
 5.16 Toothsetter Gauge Assembly 5-26

SECTION 6 ELECTRICAL INFORMATION

6.1 Schematic, AC 120V5-27

6.2 Schematic, AC 220V5-29

6.3 Schematic, DC5-31

6.4 Component Layout Diagrams (AC Only)5-32

Front Panel, Control Box..... 5-32

Insert Panel, Control Box 5-32

6.5 Component Layout Diagrams (DC Only)5-33

Front Panel, Control Box..... 5-33

6.6 Component List (AC Only)5-34

6.7 Component List (DC Only)5-35

SECTION 1 INTRODUCTION

1.1 About This Manual

This manual replaces any previous information received on your Wood-Mizer® equipment.

The information and instructions in this manual do not amend or extend the limited warranties for the equipment given at the time of purchase.

1.2 Getting Service

For contact information, sales, service, parts, and additional manuals, sign into your account on <https://woodmizer.com>, or call inside the USA: 1-800-553-0182 or from outside the USA: 317-271-1542

1.3 Specifications

Equipment specification are included in the Online Manuals, which are found at <https://apps.woodmizer.com/Manuals/Manuals.aspx?parent=0>.

1.4 Dimensions and Specifications

The overall dimensions and weight are listed below.

	Length	Width	Height	Weight
BMT200	74" (1880 mm)	116 3/4" (2965 mm)	16 1/2" (419 mm)	90 lbs. (41 kg)
BMT250	74" (1880 mm)	116 3/4" (2965 mm)	16 1/2" (419 mm)	105 lbs. (47.5 kg)

The Dual Toothsetter models are listed below.

Model	Voltage Code ¹	Electrical Standard Code ²	Electrical Package	Description
BMT200	---	---	---	Dual Toothsetter w/Manual Crank
BMT250	M	U	EP	AC Automatic Dual Toothsetter (1 x 110V 60Hz)
BMT250	A	S	EP	AC Automatic Dual Toothsetter (1 x 230V 50Hz)
BMT250	M	U	D	DC Automatic Dual Toothsetter (1 x 110-230V 50/60Hz)

¹ M - 1 x 110V; A - 1 x 230V.

² U - UL (60Hz); S - CE (50Hz).

The motor specifications are listed below.

Motor	Manufacturer	Model	Rated Output	Rated Current	Rated Speed
Electric	Besel S.A., Poland	SKh 63-4A2	0.16 HP (0.12 kW)	0.80A at 230V 0.45A at 400V	1380 RPM
Electric	---	---	1/5 HP	---	32 RPM

The noise level of the operating BMT250 Dual Toothsetter is listed below.¹

Model	Noise Level
BMT250	dB (A)

1. The figures quoted are emission levels and are not necessarily safe working levels. Although there is a correlation between the emission and exposure levels, this cannot be used reliably to determine whether or not further precautions are required. Factors that influence the actual level of exposure of the workforce include the characteristics of the work room and the other sources of noise etc. i.e. the number of machines and other adjacent processes. Also, the permissible exposure level value may vary from country to country. This information, however, will enable the user of the machine to make a better evaluation of the hazards and risk.

1 Introduction

Dimensions and Specifications

The maximum electrical loads are listed below.

Model	Maximum Load
BMT250 (1 x 110V AC 60Hz)	6.8 Amps
BMT250 (1 x 220V AC 50/60Hz)	3.95 Amps

DANGER! Make sure all electrical installation, service and/or maintenance work is performed by a qualified electrician and is in accordance with applicable electrical codes.

DANGER! It is recommended that a 30mA Ground Fault Interrupter (GFI) be used.

Dimensions of the Dual Setter are shown below.

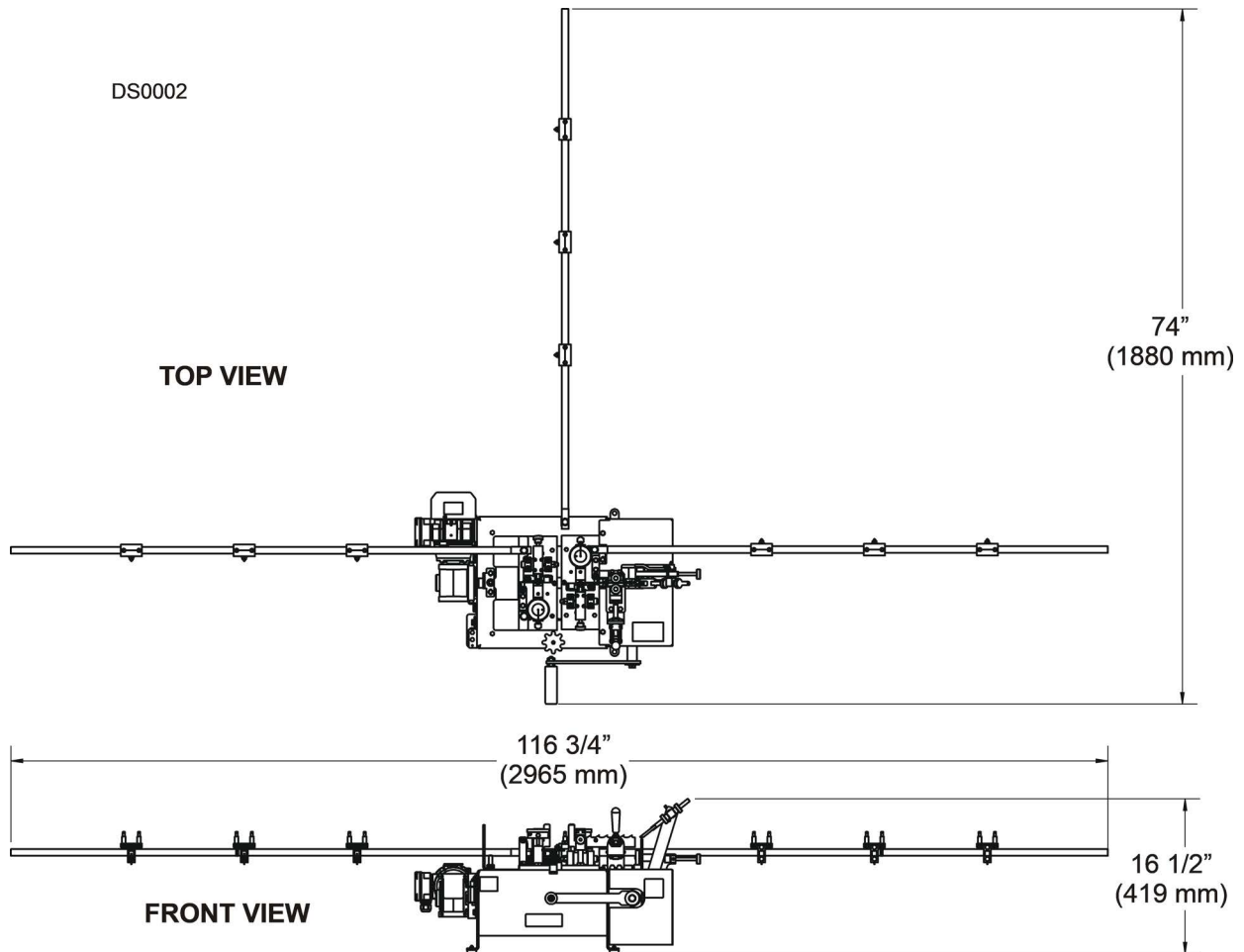



FIG. 1-1

SECTION2 GENERAL SAFETY

2.1 Safety Symbols

The following symbols and signal words call your attention to instructions concerning your personal safety. Be sure to observe and follow these instructions.

 **DANGER!** indicates an imminently hazardous situation which, if not avoided, will result in serious injury or death.

 **WARNING!** suggests a potentially hazardous situation which, if not avoided, could result in serious injury or death.

 **CAUTION!** refers to potentially hazardous situations which, if not avoided, may result in minor or moderate injury or damage to equipment.

NOTICE indicates vital information.

2.2 Safety Instructions

OWNER/OPERATOR'S RESPONSIBILITY

The procedures listed in this manual may not include all ANSI, OSHA, or locally required safety procedures. **It is the owner/operator's responsibility and not Wood-Mizer LLC to ensure all operators are properly trained and informed of all safety protocols.** Owner/Operators are responsible for following all safety procedures when operating and performing maintenance to the equipment.

Observe ALL Safety Instructions

NOTICE Read the entire Operator's Manual before operating this equipment.

Note all safety warnings throughout this manual and those posted on the machine.

Be able to access this manual at all times while operating this equipment.

Read additional manufacturer's manuals (motor) and observe their applicable safety instructions.

Only persons who have read and understood the entire operator's manual should operate this equipment.

This equipment is not intended for use by or around children.

It is the owner/operator's responsibility to comply with all applicable federal, state, and local laws, rules, and regulations regarding the ownership, operation, and transporting your equipment.

WEAR SAFETY CLOTHING

 **WARNING!** Secure all loose clothing and jewelry before operating the equipment.

Always wear eye, ear, and foot protection when operating or servicing the equipment.

Wear hand protection while handling blades.

KEEP HANDS AWAY

 **DANGER!** Remove power before clearing debris or any other maintenance activity.

Shut off the equipment before changing the blade.

Ensure all guards are in place before operating.

 **WARNING!** Avoid contact with any hot parts (motors).

Allow the system to cool sufficiently before beginning any service function, including debris removal.

Avoid contact with sharp edges of the cutting blades.

Stay a safe distance from rotating members (shafts, pulleys, fans, etc.) and ensure loose clothing or long hair does not engage rotating members

KEEP SAFETY LABELS IN GOOD CONDITION

NOTICE Ensure that all safety decals are clean and readable. Replace all damaged safety decals to prevent personal injury or damage to the equipment. Contact your local distributor, or call your Customer Service Representative to order more decals.

If replacing a component that has a safety decal affixed to it, ensure the new component also has the safety decal affixed.

2.3 Electrical Lockout Procedures

RULES FOR USING LOCKOUT PROCEDURE

The equipment shall be locked out to protect against accidental or inadvertent operation when such operation could cause injury to personnel. Do not attempt to operate any switch or valve bearing a lock.

LOCKOUT PROCEDURES MUST BE USED DURING, BUT NOT LIMITED TO:

- Changing or adjusting blades
- Unjamming operations
- Cleaning
- Mechanical repair
- Electrical maintenance
- Retrieval of tools/parts from work area
- Activities where guards or electrical panel guard is open or removed

MAINTENANCE HAZARDS INCLUDE, BUT NOT LIMITED TO:

- Blade contact
- Pinch points
- Kickbacks
- Missiles (thrown blades/wood chips)
- Electrical

FAILURE TO LOCKOUT MAY RESULT IN, BUT NOT LIMITED TO:

- Cut
- Crush
- Blindness
- Puncture
- Electrocution
- Serious injury and death

- Amputation
- Burn
- Shock

TO CONTROL MAINTENANCE DANGERS:

- Lockout procedures must be followed (see **OSHA regulation 1910.147**).
- Never rely on machine stop control for maintenance safety (emergency stops, on/off buttons, interlocks).
- Do not reach into moving blades or feed systems. Allow all coasting parts to come to a complete stop.
- Electrical power supply and air supply must both be locked out.
- Where established lockout procedures cannot be used (electrical troubleshooting or mechanical dynamic troubleshooting), alternative effective protective techniques shall be employed which may require special skills and planning.
- Always follow safe operations practices in the workplace.

EQUIPMENT LOCKOUT PROCEDURE

Lockout procedures per OSHA regulation 1910.147, appendix A:

GENERAL

The following simple lockout procedure is provided to assist owner/operators in developing their procedures so they meet the requirements of **OSHA regulation 1910.147**. When the energy isolating devices are not lockable, tagout may be used, provided the owner/operator complies with the provisions of the standard which require additional training and more rigorous periodic inspections. When tagout is used and the energy isolating devices are lockable, the owner/operator must provide full operator protection (see OSHA regulation 1910.147, paragraph (c)(3)) and additional training and more rigorous periodic inspections are required. For more complex systems, more comprehensive procedures may need to be developed, documented, and utilized.

PURPOSE

This procedure establishes the minimum requirements for the lockout of energy isolating devices whenever maintenance or servicing is done on machines or equipment. It shall be used to ensure that the machine or equipment is stopped, isolated from all potentially hazardous energy sources and locked out before personnel perform any servicing or maintenance where the unexpected energization or start-up of the machine or equipment or release of stored energy could cause injury.

COMPLIANCE WITH THIS PROGRAM

All personnel are required to comply with the restrictions and limitations imposed upon them during the use of lockout. The authorized personnel are required to perform the lockout in accordance with this procedure. All operators, upon observing a machine or piece of equipment which is locked out to perform servicing or maintenance shall not attempt to start, energize, or use that machine or equipment.

SEQUENCE OF LOCKOUT

1. Notify all affected personnel that servicing or maintenance is required on a machine or equipment and that the machine or equipment must be shut down and locked out to perform the servicing or maintenance.
2. The authorized employee shall refer to the company procedure to identify the type and magnitude of the energy that the machine or equipment utilizes, shall understand the hazards

of the energy, and shall know the methods to control the energy.

3. If the machine or equipment is operating, shut it down by the normal stopping procedure (depress the stop button, open switch, close valve, etc.).
4. De-activate the energy isolating device(s) so that the machine or equipment is isolated from the energy source(s).
5. Lock out the energy isolating device(s) with assigned individual lock(s).
6. Stored or residual energy (such as that in capacitors, springs, elevated machine members, rotating flywheels, hydraulic systems, and air, gas, steam, or water pressure, etc.) must be dissipated or restrained by methods such as grounding, repositioning, blocking, bleeding down, etc.
7. Ensure that the equipment is disconnected from the energy source(s) by first checking that no personnel are exposed, then verify the isolation of the equipment by operating the push button or other normal operating control(s) or by testing to make certain the equipment will not operate.



CAUTION! Return operating control(s) to neutral or "off" position after verifying the isolation of the equipment.

8. The machine or equipment is now locked out.

RESTORING EQUIPMENT TO SERVICE

When the servicing or maintenance is completed and the machine or equipment is ready to return to normal operating condition, the following steps shall be taken.

1. Check the machine or equipment and the immediate area around the machine to ensure that nonessential items have been removed and that the machine or equipment components are operationally intact.
2. Check the work area to ensure that all personnel have been safely positioned or removed from the area.
3. Verify that the controls are in neutral.
4. Remove the lockout devices and re-energize the machine or equipment.

NOTE: The removal of some forms of blocking may require re-energization of the machine before safe removal.

5. Notify affected personnel that the servicing or maintenance is completed and the machine or equipment is ready for use.

PROCEDURE INVOLVING MORE THAN ONE PERSON

In the preceding steps, if more than one individual is required to lock out the equipment, **each shall place his own personal lock on the energy isolating devices.**

SECTION 3 SETUP & OPERATION

3.1 Assembly

Place the setter on a table or workbench sturdy enough to support the weight of the machine. Be sure there is enough room on either side of the setter to allow for the blade to travel.

The unit will rest on the rubber feet on the bottom of the machine. If desired, the unit can be bolted to the table through the holes provided in the bottom of the base frame.

Blade Support Arms

NOTE: The blade support arms supplied with the setter are capable of supporting most blades up to 1 1/2" wide. An upgrade kit is available to increase the support arm capability to support heavier blades ([See Section 5.1](#)).

There are arm mounting locations at the right side, left side and rear of the machine. Install the spacer bushings and one arm mount block at each location. Secure each block with a provided 10mm lock washer and M10-1.5 x 80 hex head bolt.

NOTE: If setting very wide blades, you may need to exclude one or more of the spacers from each location to ensure the blade is positioned properly in the clamp. If installing the optional arm kit for heavier blades, replace the arm mounting blocks with the extension arms. Install the long extension arms to the left and right positions and the short arm to the rear position.

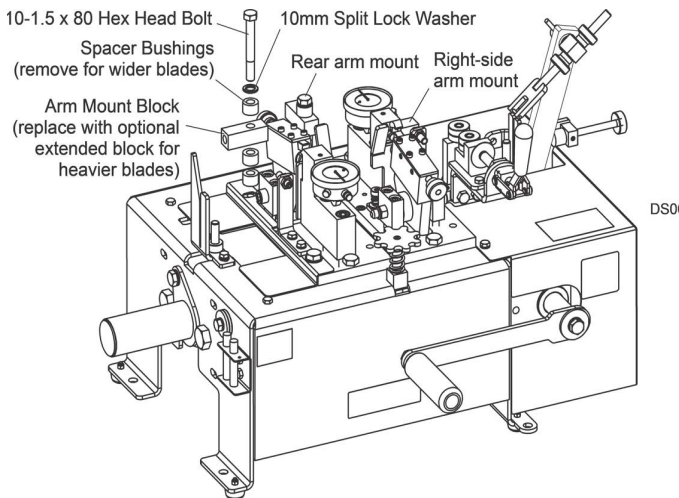

FIG. 3-1

Thread a blade support tube into the threaded holes in the three mounting blocks. Assemble a blade support extension tube to each blade support tube.

NOTE: If installing the optional arm kit for heavier blades, assemble the blade support extension tubes to the extended mounting arms.

Install at least one blade support guide to each support tube with two 1/4-20 x 1 1/2" hex head bolts, flat washers, self-locking nut and wing nut. The position of the guides will be adjusted later. Three guide assemblies are provided for each arm so you can setup for different blade lengths without having to adjust the guide assembly.

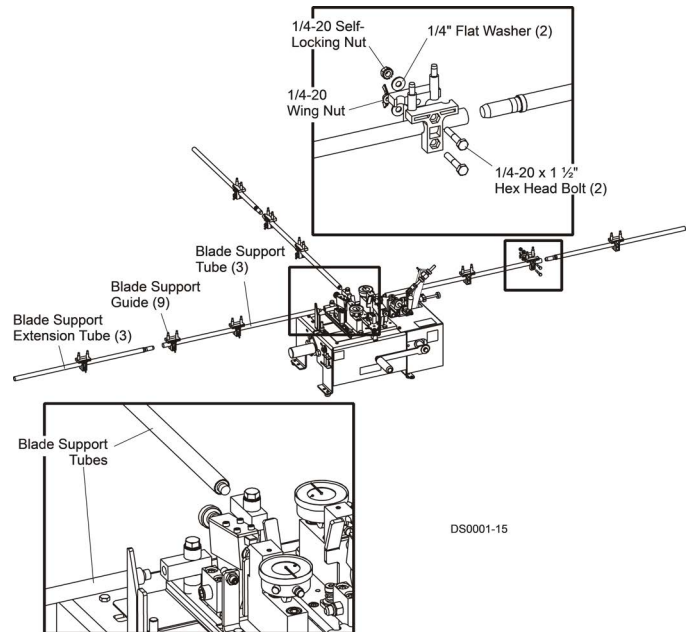

FIG. 3-2

Auto Feed Installation (Optional - AC Only)

The AC Auto Feed Option includes an electric motor and control to automate the setting process.

Before installing the Auto Feed, remove the manual feed crank handle. Disassemble the bolt, lock washer and fender washer to remove the handle. Remove the M10-1.25 x 20 hex head bolt, split lock washer and the shaft cover mounted to the left side of the setter assembly. Remove the index cover and use the existing M10-1.25 x

3 Setup & Operation

Auto Feed Installation (Optional - DC Only)

20 hex head bolt and split lock washer to reinstall the shaft cover over the manual feed shaft.

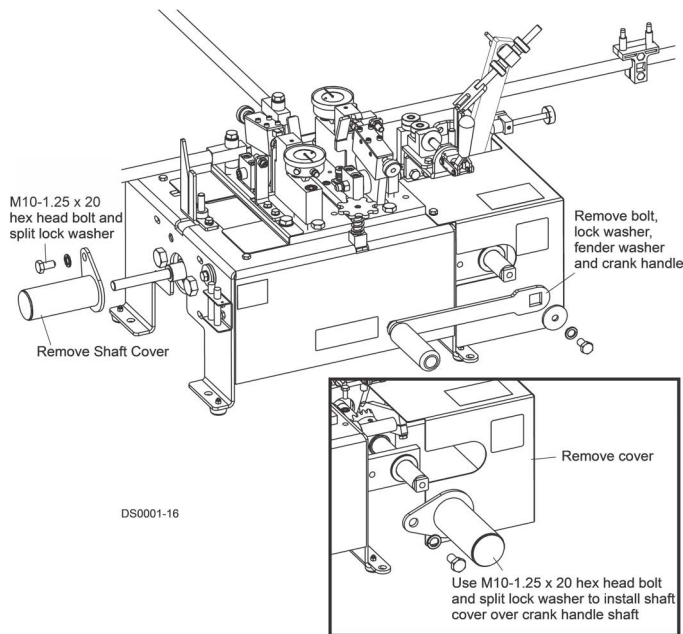

FIG. 3-3

Install two 5 x 5 x 25mm round end keys to the feed shaft and slide the motor with the mount plate onto the feed shaft. Secure the motor to the setter base.

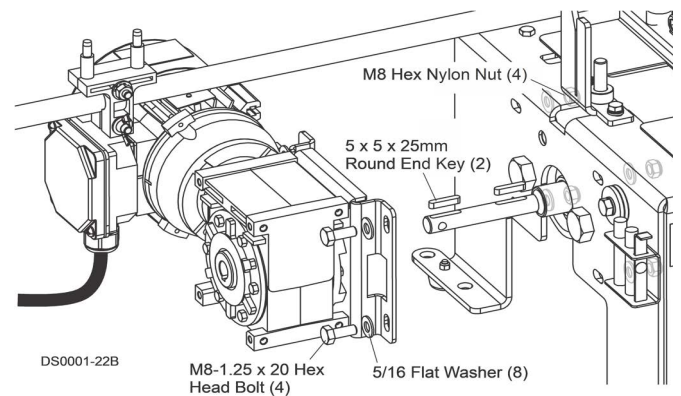

FIG. 3-4

Set the Auto Feed control box near the setter at a convenient operating location. Secure the motor harness with wire ties as necessary.

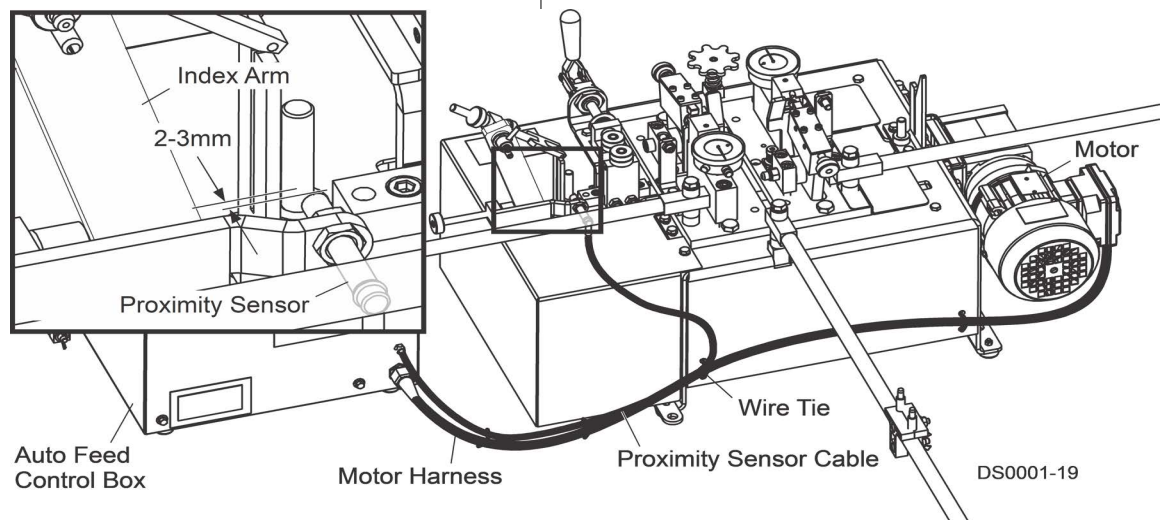

FIG. 3-5

Install the proximity sensor to the stop plate next to the setter index assembly. Make sure the proximity sensor is approximately 2-3 millimeters from the index arm. Connect the proximity sensor cable from the control box to the proximity sensor. Secure the cable to the motor harness as necessary.

Plug the power cord from the control box into a grounded receptacle. **NOTE:** The control is equipped with an auto-voltage detect feature. Simply use an appropriate adaptor plug or modify the power cord to match your receptacle.



DANGER! For the user's safety, the power cord on this product has a grounded plug. This power cord should only be used with correctly grounded (3-hole) receptacles to avoid electrical shock.

Auto Feed Installation (Optional - DC Only)

The DC Auto Feed Option includes an electric motor and control to automate the setting process.

Before installing the Auto Feed, remove the manual feed crank handle. Disassemble the bolt, lock washer and fender washer to remove the handle. Remove the M10-1.25 x 20 hex head bolt, split lock washer and the shaft cover mounted to the left side of the setter assembly. Remove the index cover and use the existing M10-1.25 x

20 hex head bolt and split lock washer to reinstall the shaft cover over the manual feed shaft.

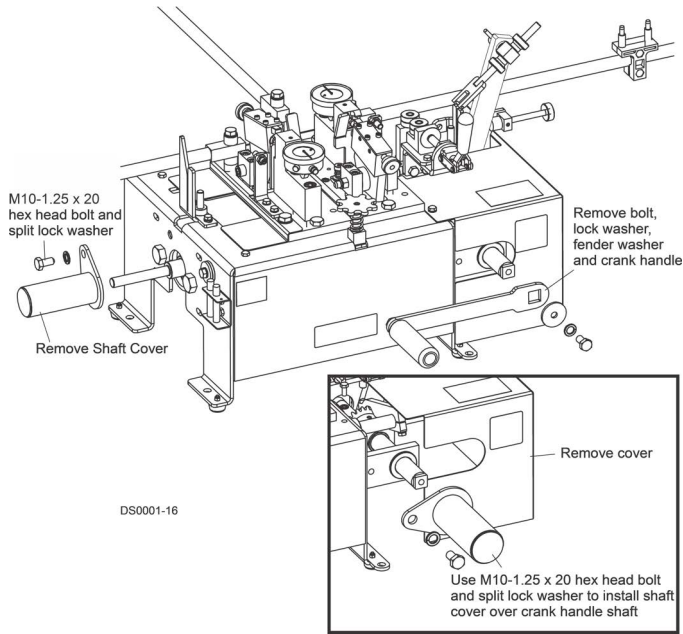

FIG. 3-6

Remove the existing shaft end bolts from the setter. Install the feed motor mount bracket around the feed shaft and secure with the provided shaft end bolts, flat washers and existing nylon lock nuts. Leave the bolts slightly loose until the motor is pinned to the feed shaft as described later.

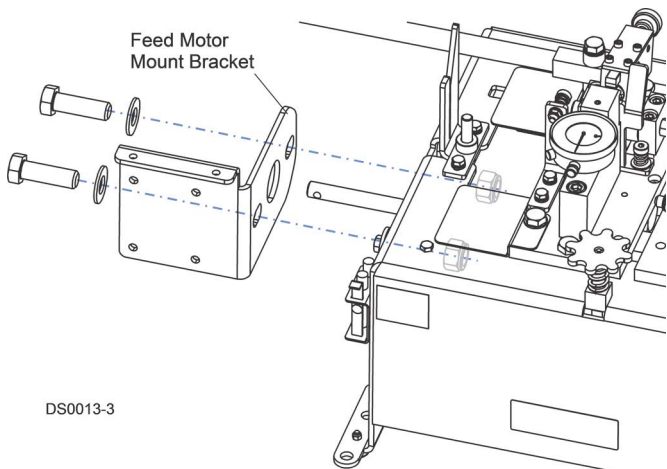

FIG. 3-7

Install the motor side brackets to the feed motor and secure with eight flanged hex head bolts.

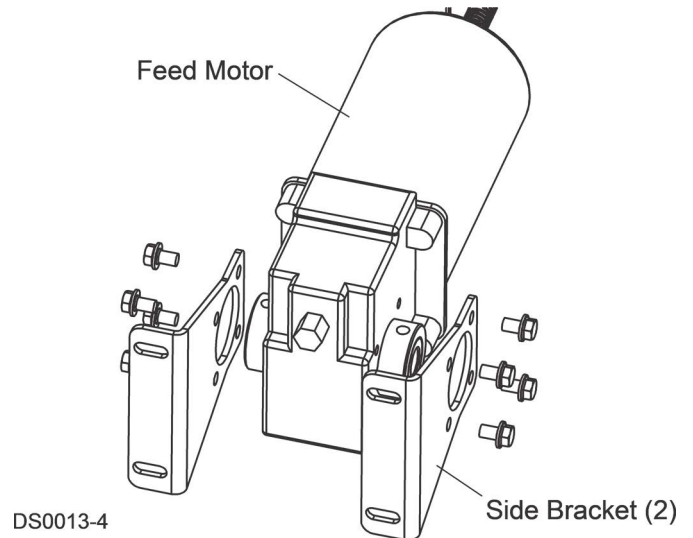

FIG. 3-8

Slide the sleeve and motor assembly onto the feed shaft and secure to the motor mount bracket with four flat washers, lock washers, hex head bolts and self-locking nuts. Leave the bolts slightly loose until the motor is pinned to the feed shaft as described later.

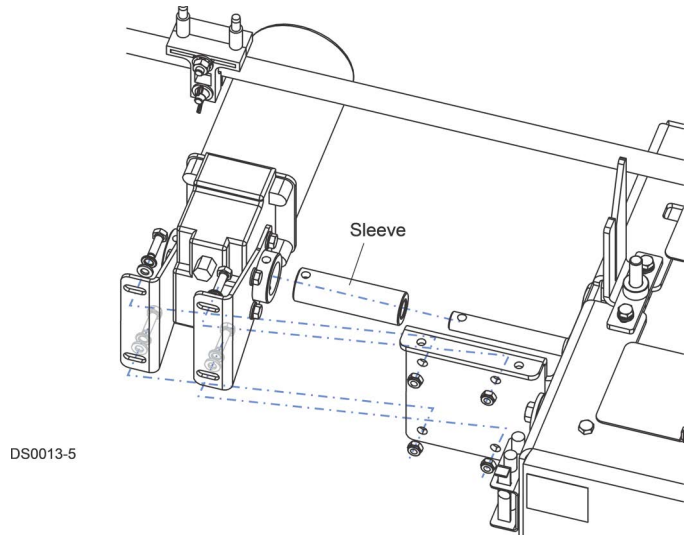

FIG. 3-9

Use a 1/2" wrench on the front hex knob to rotate the motor shaft to align the hole in the outer collar with the hole in the feed shaft. With the motor mount bolts still loose, adjust the assembly if necessary until the holes line up exactly. Install the provided roll pin to secure the motor assembly to the shaft. Tighten the feed shaft end bolts and motor mount

3 Setup & Operation

Auto Feed Installation (Optional - DC Only)

bolts and install the motor top cover with two hex head bolts, flat washers and lock nuts.

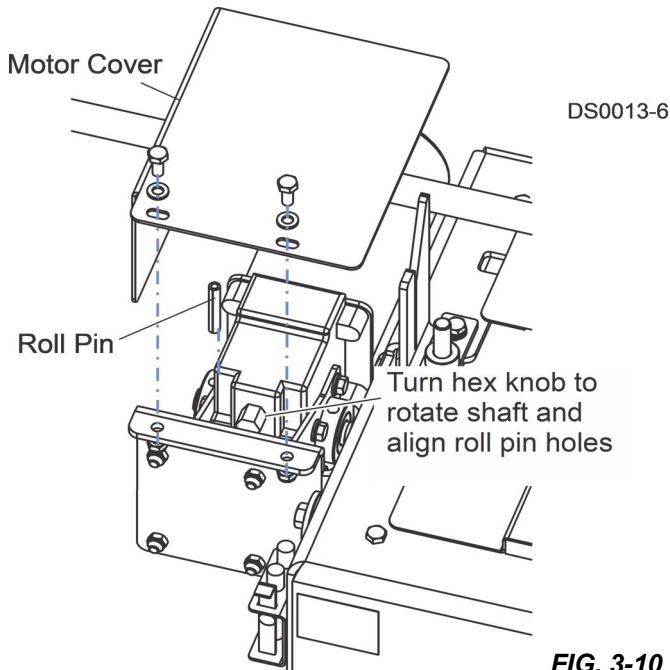

Set the Auto Feed control box near the setter at a convenient operating location. Connect the motor harnesses with two-pin connectors together. Secure the motor harness with wire ties as necessary.

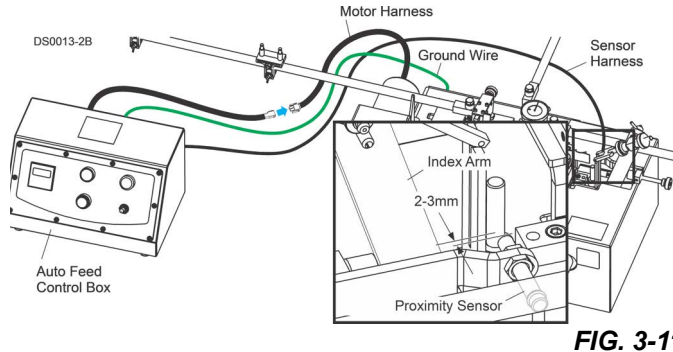

Install the proximity sensor to the stop plate next to the setter index assembly. Make sure the proximity sensor is approximately 2-3 millimeters from the index arm. Secure the cable to the motor harness as necessary.

Plug the power cord from the control box into a grounded receptacle. **NOTE:** The control is equipped with an auto-voltage detect feature. Simply use an appropriate adapter plug or modify the power cord to match your receptacle.

Connect the ground wire from the control box to one of the holes located on the back of the setter base.



DANGER! For the user's safety, the power cord on this product has a grounded plug. This power cord should only be used with correctly grounded (3-hole) receptacles to avoid electrical shock.

3.2 Dual Setter Calibration

WARNING! Always wear gloves and eye protection when handling bandsaw blades. Changing blades is safest when done by one person! Keep all other persons away from area when coiling, carrying or changing a blade. Failure to do so may result in serious injury.

For the calibration and alignment video, scan the QR code below.



BMT200 and BMT250 Tooth Setter Alignment and Calibration

Tooth Set Master Gauge Calibration

The tooth set gauge accurately measures the set of any blade tooth. The gauge needs to be assembled and calibrated before use.

Insert the dial gauge assembly into the hole in the block housing. Clamp the calibrating pin in position at the center of the dial gauge foot. Push the gauge assembly forward until the foot just touches the pin and dial needle moves .005 to .010. Tighten the locking screw with the provided hex wrench (do not overtighten). Loosen the dial lock on the gauge and rotate the dial face until the needle reads zero. Tighten the dial lock

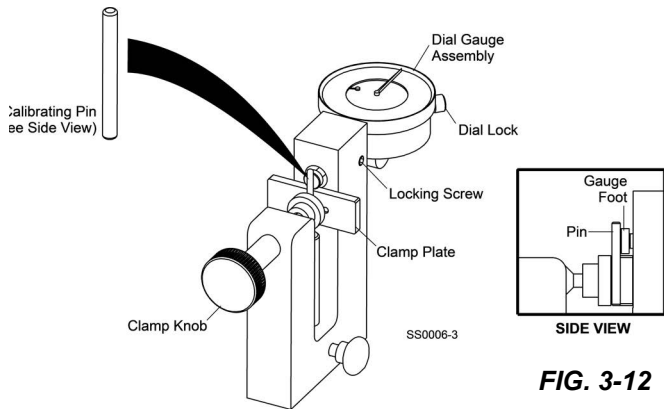

FIG. 3-12

Unclamp the calibrating pin from the set master gauge clamp by turning the clamp knob counterclockwise. With the pin not clamped, the set master gauge needle should read between -.005 and -.010. If not, reclamp the pin,

loosen the locking screw and move the set master gauge assembly back so the foot does not contact the pin. Repeat the steps above until the dial needle reads zero with the calibrating pin clamped and between -.005 and -.010 without the pin clamped. This ensures the dial foot extends beyond the clamp plate a slight amount and will read zero when the foot is aligned with the clamp plate.

Dual Setter Calibration

Pull the blade clamp lever open and flip the index arm up.

NOTE: The beveled edge on the indexer pawl must be downward facing.

Turn the feed handle counterclockwise (or push and hold the Auto Feed option START - JOG button) to advance the setter until the setter assemblies open.

Loop the blade over the setter and position between the posts of the blade support guides. Place the blade between the clamp rollers and between the setter blocks, resting on the blade height adjustment pins.

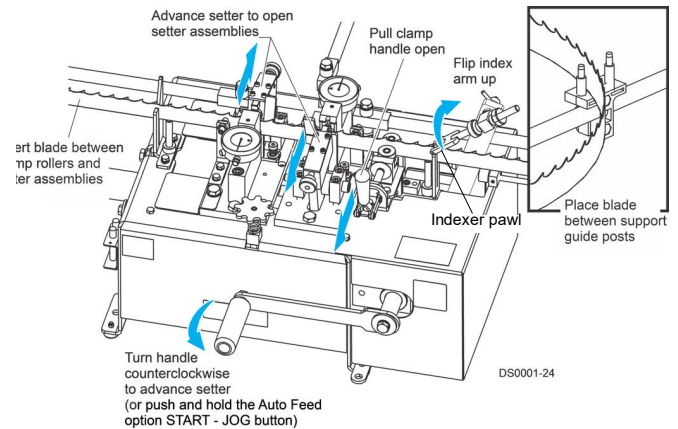

FIG. 3-13

Place the set master gauge around the blade to measure tooth set. Turn the lock knob counterclockwise to loosen and adjust the blade height rest pin up or down. Adjust so when the blade rests on the pin, the tip of the tooth is approximately centered on gauge foot. Retighten the lock knob.

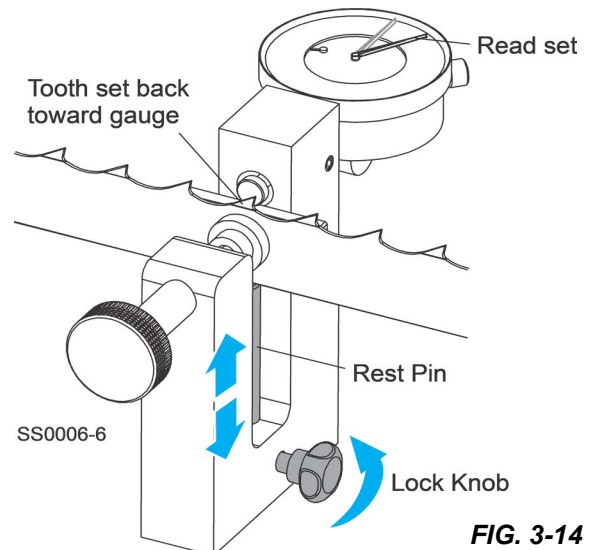

FIG. 3-14

3 Setup & Operation

Dual Setter Calibration

Slide the set master gauge assembly through the blade until a tooth set back toward the gauge is positioned in front of the dial plunger.

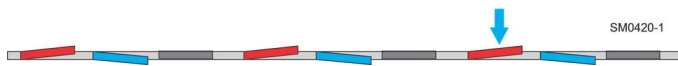

FIG. 3-15

Turn the clamp knob clockwise to securely clamp the blade and read the set measurement displayed by the set master gauge. Note the tooth set measurement and mark the measured tooth with a marker.

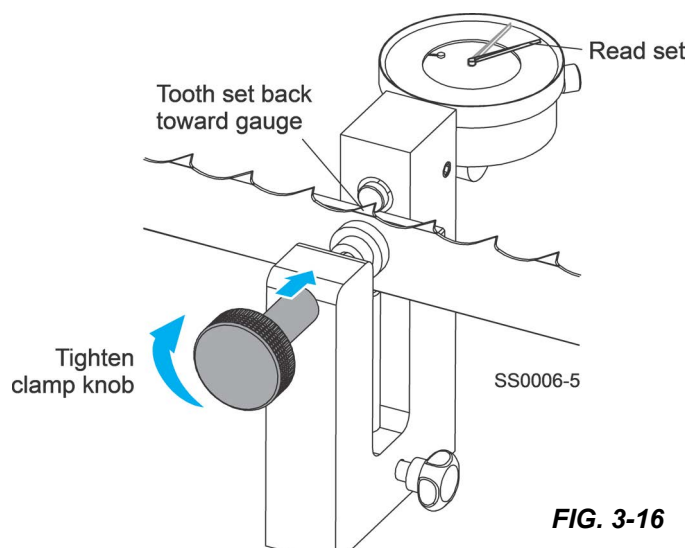

FIG. 3-16

Loosen the clamp knob and remove the set master gauge assembly from the blade. Rotate the set master gauge to the other side of the blade to measure tooth set in the opposite direction.

Find the sixth tooth for blades with 7/8" and 1-1/8" tooth spacing or the eighth tooth for blades with 1/2", 5/8" and 3/4" tooth spacing (blades with other tooth spacing may require a different tooth count) to the left set in the opposite direction and place the set master gauge around the blade to measure tooth set. Note the tooth set measurement and mark the measured tooth with a marker. Loosen the clamp knob and remove the set master gauge assembly from the blade.

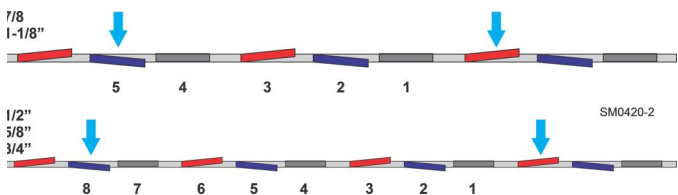
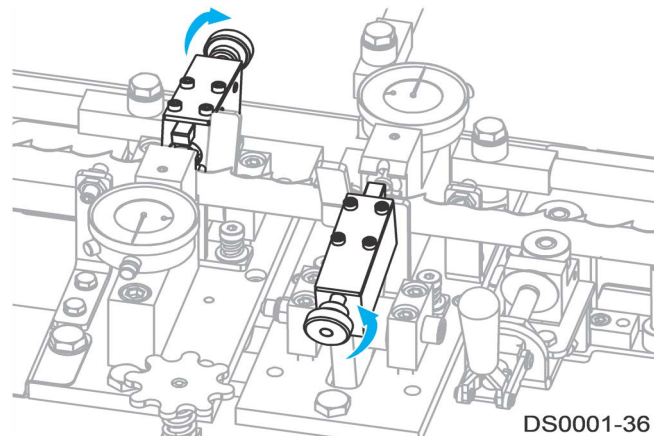

FIG. 3-17

NOTE: The setter is factory-set for blades with 7/8" tooth spacing. Once a rear-set tooth is indexed in front of the right setter block, a forward-set tooth should be positioned in front of the left setter block. To adjust the setter for different tooth spacing, loosen the left setter mounting bolts and slide the assembly to position the setter block behind a forward-set tooth. Retighten the mounting bolts.

Adjust the knobs on the left and right setter assemblies to back off the setter blocks completely (the blocks will need

to be pushed in manually because they are not spring loaded). Position the blade so that the teeth measured with the set master gauge are located in the left and right setter assemblies. Make sure the blocks are backed off far enough so they do not contact the blade. Adjust the blade height adjustment pins so the tip of the tooth is approximately centered on gauge foot.



DS0001-36
FIG. 3-18

Turn the feed handle counterclockwise (or push and hold the AUTO FEED option START - JOG button) to advance the setter until the setter assemblies start to close. Stop the setter when the setter assemblies are closed but the setter pushers do not contact the blade teeth.

Unlock the dial lock and adjust the setter gauge bezels so the needles of the setter gauges show the same tooth set measurements taken previously with the set master gauge.

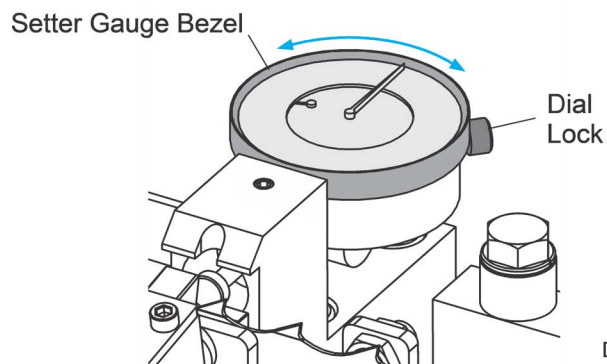

DS0001-36
FIG. 3-19

3.3 Operation

Blade Installation/Setup

WARNING! Always wear gloves and eye protection when handling bandsaw blades. Changing blades is safest when done by one person! Keep all other persons away from area when coiling, carrying or changing a blade. Failure to do so may result in serious injury.

WARNING! The toothsetter should be operated only by adults who have read and understood the entire operator's manuals.

WARNING! The illumination at the operator's position should be at least 300 lux. The light source can not cause stroboscopic effect.

AUTO FEED Option Only: Toggle the power ON/OFF switch on the back of the control box to the ON (I) position. Be sure the AUTO/MANUAL switch is in the MANUAL position.

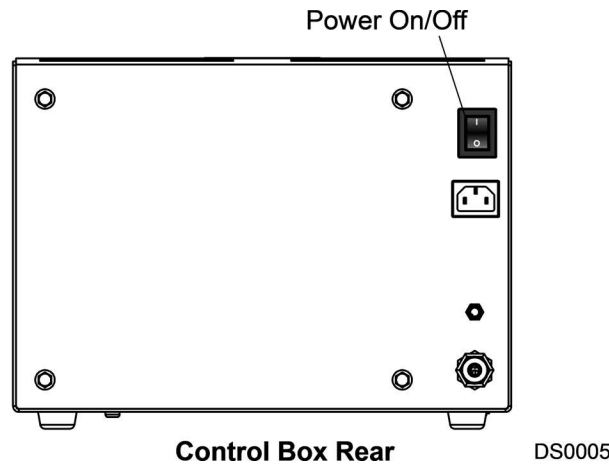
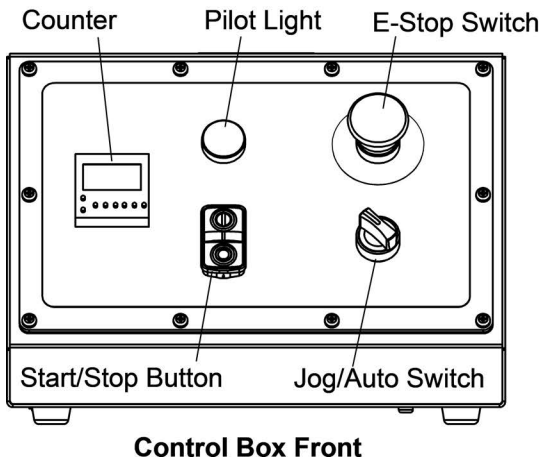

FIG. 3-20 AC ONLY

WARNING! AC Only: If at any time you need to immediately stop the machine, press the Emergency Stop (E-Stop) button. Before operating the

machine again, turn the E-Stop button clockwise to release. The machine will not start until the E-Stop button is released.

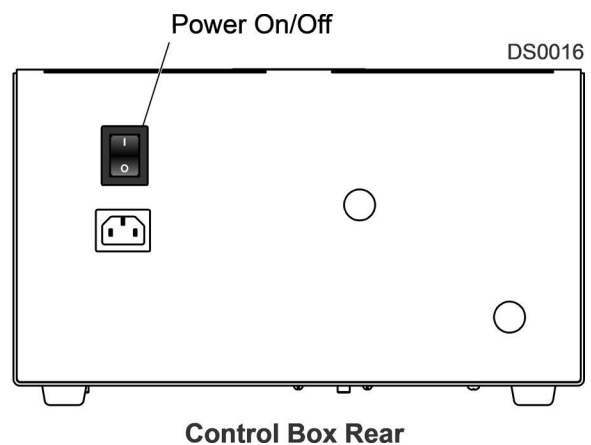
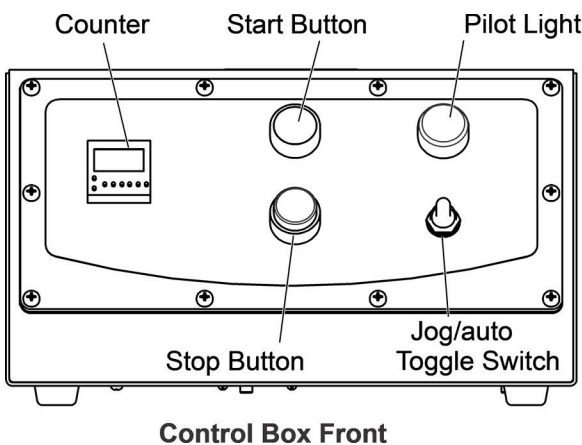

FIG. 3-21 DC ONLY

NOTE: Most blades manufactured by Wood-Mizer are made so the set pattern across the weld is consistent with the rest of the blade. You should mark your blade for the starting point or start at the weld. If the set pattern across the weld is not consistent, start the blade with the weld to the left of the left side setting clamp and end the cycle when the weld gets to the right of

the right setting clamp. To prevent resetting the teeth in the opposite direction, count the number of teeth between the two clamp blocks, subtract the number from the total quantity of teeth on the blade, and enter the result in the setter tooth counter. Use the provided bend back tool (023774) to set the teeth that are between the setter clamps.

3 Operation Blade Installation/Setup

The quantity of teeth on any particular blade depends on the length and tooth spacing of the blade. Common blade tooth quantities are provided below.

		Tooth Spacing		
		0.656"	0.875"	1.125"
Blade Length	144"	220	165	128
	158"	241	180	140
	178"	272	203	200
	184"	280	210	163
	205"	312	234	182
		No. of Teeth		

TABLE 3-1

Pull the blade clamp lever open and flip the index arm up. Turn the feed handle counterclockwise (or push and hold the Auto Feed option START - JOG button) to advance the setter until the setter assemblies open.



WARNING! Before installing the blade, inspect it for damage and cracks. Always handle the blade with extreme care. Use suitable carrier equipment for transporting the blades.

Loop the blade over the setter and position between the posts of the blade support guides. Place the blade between the clamp rollers and between the setter blocks, resting on the blade height adjustment pins and rear blade support guides.

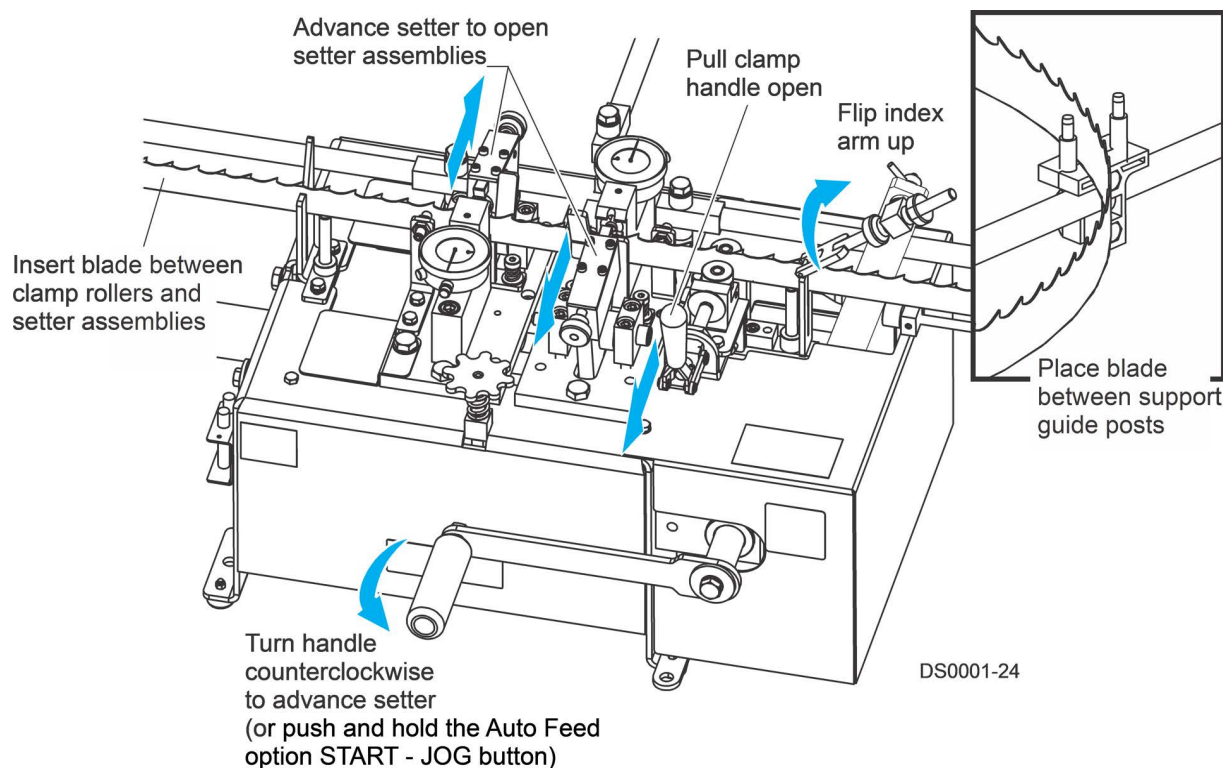

FIG. 3-22



IMPORTANT! The bottom of the blade should not touch the left or right support guides.

Loosen the wing nut on each blade support guide and adjust so the blade is positioned between the support posts. Tilt the guide slightly forward in the direction the blade travels and retighten the wing nut.



IMPORTANT! Make sure the blade support does not lift the blade. The blade should sit flat on the blade height adjustment pins. Bend the support arm down slightly if necessary to prevent it from lifting the blade. The bottom of the blade should not touch the left or right blade support guides. See FIG. 3-23.

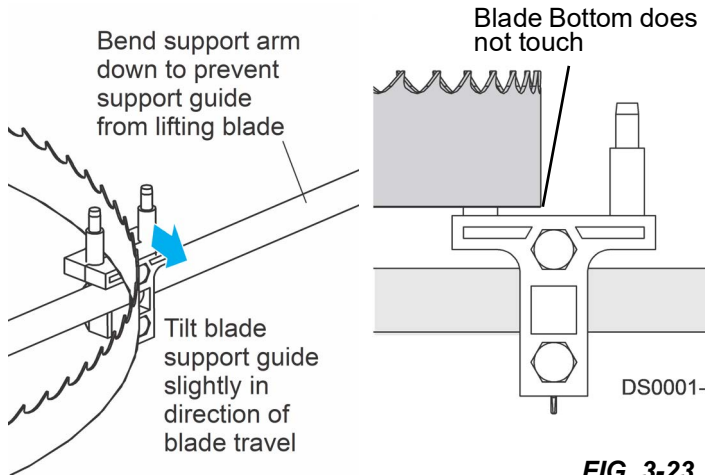

FIG. 3-23

Adjust the blade height adjustment pins so the tip of the tooth is approximately centered on gauge foot. Push the clamp handle closed and flip the index arm down onto the blade.

NOTE: Use the 3/8" x 2 1/4" blade height adjustment pins (F05012-106) for 2"-3" blades and the 3/8" x 3 1/4" blade height adjustment pins (F05012-130) for 1"-2" blades.

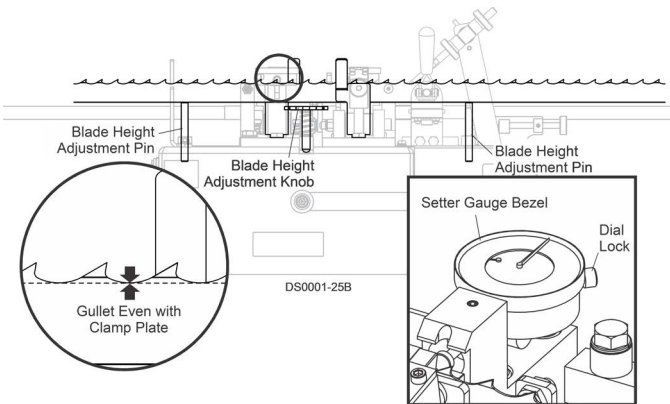

FIG. 3-24

Turn the feed handle counterclockwise (or push and hold the AUTO FEED option START - JOG button) to advance the setter until the index arm fully extends, pushing the blade forward. Stop the setter before the setter assemblies start to close.

Adjust the blade to the left in the setter until a tooth set toward the rear (or left) of the setter is positioned in front of the right setter block. Push the blade to the right until the third tooth from the right of the setter assembly is snug against the index pin. The rear or left set tooth should be set approximately centered in the right setter assembly.

Check the position of the rear-set tooth in relation to the right setter block. The tooth should be approximately centered with the block. Turn the adjustment knobs on the index arm if necessary so that rear-set tooth is approximately centered with the setter block.

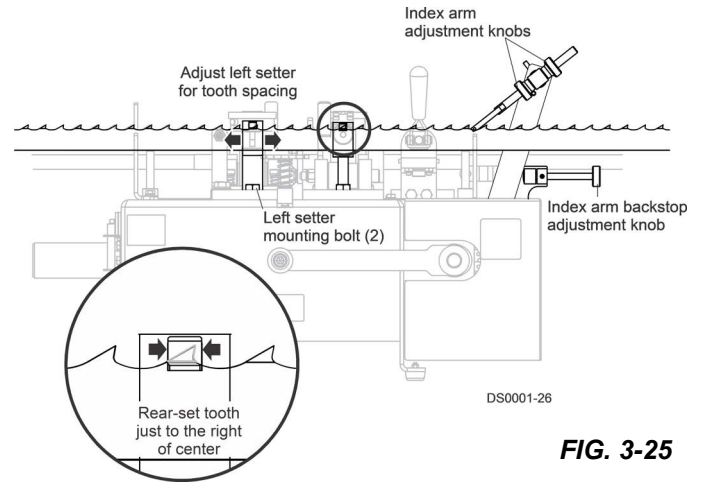

FIG. 3-25

Continue advancing the setter until the index arm retracts and just starts to move forward. The index arm should move three teeth from the one previously indexed. Turn the backstop adjustment knob in to increase the index return travel or out to decrease travel.

NOTE: The setter is factory-set for blades with 7/8" tooth spacing. Once a rear-set tooth is indexed in front of the right setter block, a forward-set tooth should be positioned in front of the left setter block. To adjust the setter for different tooth spacing, loosen the left setter mounting bolts and slide the assembly to position the setter block behind a forward-set tooth. Retighten the mounting bolts.

Perform the calibration procedure to make sure the gauge assemblies are adjusted properly ([See Section 3.2](#)).

Continue advancing the setter to index the blade to the next set of teeth. Stop the setter when the setter assemblies are completely closed. Turn the setter block adjustment knobs until the blocks just contact the blade teeth. Advance the setter to open the setter assemblies and turn the setter block adjustment knobs a few more turns.

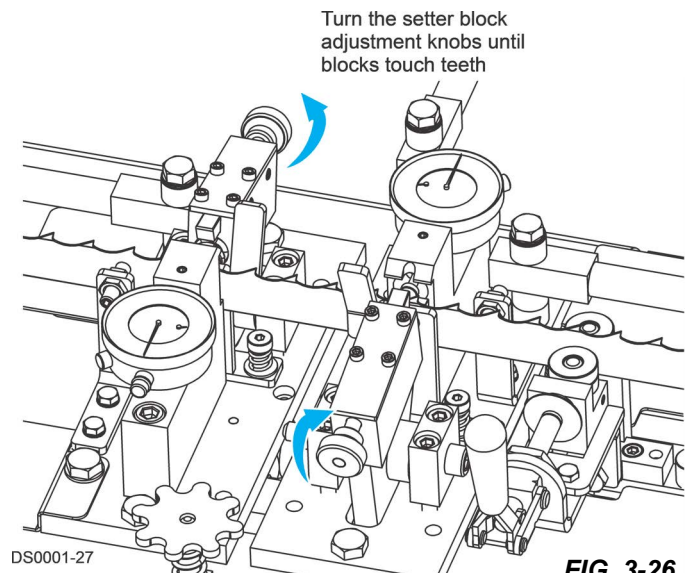

FIG. 3-26

Use the tabs on the gauges to bracket the desired set. The typical deviation allowed is .002 (the desired set shown)

3 Operation Manual Feed Operation

below is 21 with tolerance 19-23). Advance the setter to index the blade to the next set of teeth. Continue advancing the setter until the setter blocks bend the teeth and indexes to the next set of teeth. Use the supplied gauge to measure the set of both the rear-set and forward-set teeth. (See [Section 3.2](#) for more information on toothsetter calibration).

If a tooth is bent too far, use the supplied set correction tool to bend the tooth back. Adjust the appropriate setter block adjustment knob to increase or decrease how far the teeth are bent.

Repeat the steps above until the desired amount of set is achieved in both the rear-set and forward-set teeth.

Manual Feed Operation



WARNING! Always wear eye protection when operating the setter. Failure to do so may result in serious injury.

Turn the feed handle clockwise to advance the setter until the setter assemblies open. Pull the clamp handle open and rotate the blade around the setter until the blade weld is positioned to the left of the left setter assembly. Position the blade against the index arm pin with a rear-set tooth aligned with the right setter block.

Push the clamp handle closed. Turn the feed handle counterclockwise to set teeth. Continue setting teeth around the blade until the weld is reached. Advance the setter to open the setter assemblies.

Flip the index arm up and pull the clamp open to remove the blade.

Auto Feed Operation

Pull the blade clamp lever open and flip the index arm up. Push and hold the Auto Feed option START - JOG button to advance the setter until the setter assemblies open.

Loop the blade over the setter and position between the posts of the blade support guides. Place the blade between the clamp rollers and between the setter blocks, resting on the blade height adjustment pins and rear blade support guides.



IMPORTANT! The bottom of the blade should not touch the left or right support guides.



WARNING! Before installing the blade, inspect it for damage and cracks. Always handle the blade with extreme care. Use suitable carrier equipment for transporting the blades.

NOTE: Most blades manufactured by Wood-Mizer are made so the set pattern across the weld is consistent with the rest of the blade. You should mark your blade for the starting point or start at the weld. If the set pattern across the weld is not consistent, start the blade with the weld to the left of the left side setting clamp and end the cycle when the weld gets to the right of the right setting clamp. To prevent resetting the teeth in the opposite direction, count the number of teeth between the two clamp blocks, subtract the number from the total quantity of teeth on the blade, and enter the result in the setter tooth counter. Use the provided be back tool (023774) to set the teeth that are between the setter clamps.

The quantity of teeth on any particular blade depends on the length and tooth spacing of the blade. Common blade tooth quantities are provided below.

		Tooth Spacing		
		0.656"	0.875"	1.125"
Blade Length	144"	220	165	128
	158"	241	180	140
	178"	272	203	200
	184"	280	210	163
	205"	312	234	182
		No. of Teeth		

TABLE 3-2

Loosen the wing nut on each blade support guide and adjust so the blade is positioned between the support posts. Tilt the guide slightly forward in the direction the blade travels and retighten the wing nut.

IMPORTANT! Make sure the blade support does not lift the blade. The blade should sit flat on the blade height adjustment pins. Bend the support arm down slightly if necessary to prevent it from lifting the blade. The bottom of the blade should not touch the left or right blade support guides.

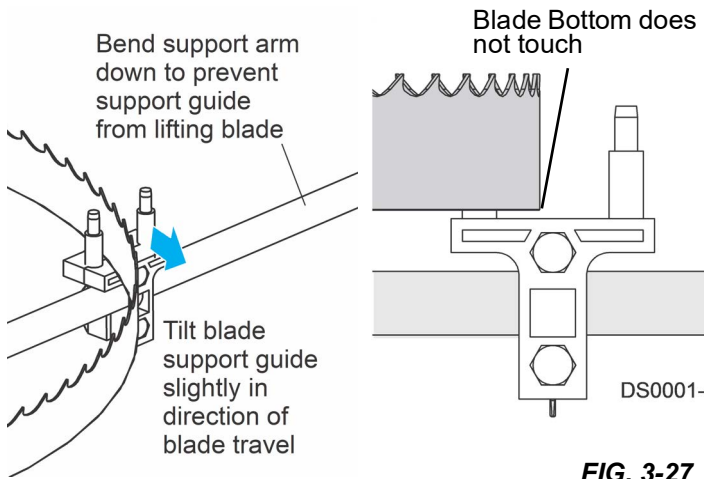

FIG. 3-27

Adjust the blade height adjustment pins so the tip of the tooth is approximately centered on gauge foot. Push the clamp handle closed and flip the index arm down onto the blade.

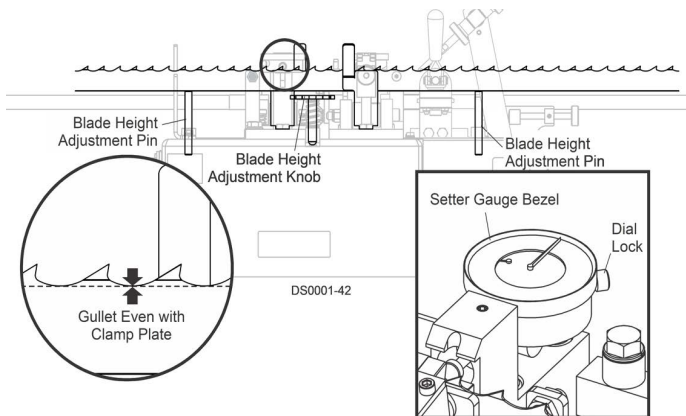

FIG. 3-28

NOTE: Use the 3/8" x 2 1/4" blade height adjustment pins (F05012-106) for 2"-3" blades and the 3/8" x 3 1/4" blade height adjustment pins (F05012-130) for 1"-2" blades.

Turn the feed handle counterclockwise (or push and hold the AUTO FEED option START - JOG button) to advance the setter until the index arm fully extends, pushing the blade forward. Stop the setter before the setter assemblies start to close.

Adjust the blade to the left in the setter until a tooth set toward the rear (or left) of the setter is positioned in front of the right setter block. Push the blade to the right until the third tooth from the right of the setter assembly is snug against the index pin. The rear or left set tooth should be set approximately centered in the right setter assembly.

Check the position of the rear-set tooth in relation to the right setter block. The tooth should be approximately centered with the block. Turn the adjustment knobs on the

index arm if necessary so that rear-set tooth is approximately centered with the setter block. Push the clamp handle closed.

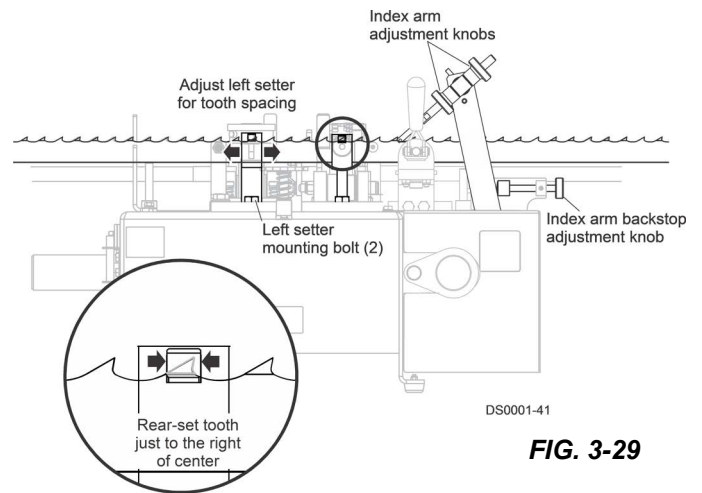

FIG. 3-29

Continue advancing the setter until the index arm retracts and just starts to move forward. The index arm should move three teeth from the one previously indexed. Turn the backstop adjustment knob in to increase the index return travel or out to decrease travel.

NOTE: The setter is factory-set for blades with 7/8" tooth spacing. Once a rear-set tooth is indexed in front of the right setter block, a forward-set tooth should be positioned in front of the left setter block. To adjust the setter for different tooth spacing, loosen the left setter mounting bolts and slide the assembly to position the setter block behind a forward-set tooth. Retighten the mounting bolts.

Perform the calibration procedure to make sure the gauge assemblies are adjusted properly ([See Section 3.2](#)).

Continue advancing the setter to index the blade to the next set of teeth. Stop the setter when the setter assemblies are completely closed. Turn the setter block adjustment knobs until the blocks just contact the blade teeth. Advance the setter to open the setter assemblies and turn the setter block adjustment knobs a few more turns.

Use the tabs on the gauges to bracket the desired set. The typical deviation allowed is .002 (the desired set shown below is 21 with tolerance 19-23).



FIG. 3-30

Continue advancing the setter until the setter blocks bend the teeth and indexes to the next set of teeth. Use the supplied gauge to measure the set of both the rear-set and forward-set teeth. ([See Section 3.2](#) for more information on toothsetter calibration).

If a tooth is bent too far, use the supplied set correction tool to bend the tooth back. Adjust the appropriate setter block

3 Operation

Auto Feed Operation

adjustment knob to increase or decrease how far the teeth are bent.

Repeat the steps above until the desired amount of set is achieved in both the rear-set and forward-set teeth.

WARNING! Always wear eye protection when operating the setter. Failure to do so may result in serious injury.

Push the START - JOG button to advance the setter until the setter assemblies open. Pull the clamp handle open and position the blade against the index arm pin with a rear-set tooth aligned with the right setter block.

Push the clamp handle closed. Enter the appropriate number of teeth on the counter. Push the lower buttons to adjust the counter setting.

NOTE: DO NOT USE THE MODE BUTTON AT ANY TIME!

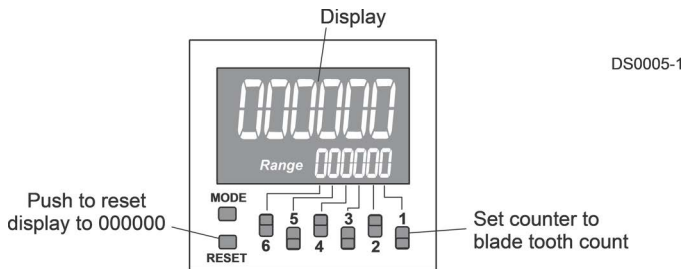

FIG. 3-31

Place the AUTO/MANUAL switch in the AUTO position. Push the START - JOG button to start setting the blade. The display value will increase as the blade passes through and the setter will stop when the display matches the counter value.

IMPORTANT! When setting Wood-Mizer blades with a raker-style pattern (one tooth bent left, one bent right and a straight tooth) the counter display should increment in multiples of three.

When done setting the blade, push the RESET button on the counter to reset the display to zero. Flip the index arm up and pull the clamp open to remove the blade. When done setting blades, toggle the power ON/OFF switch on the back of the control box to the OFF (O) position.

NOTE: The MODE button is used only to configure the counter settings for Wood-Mizer application.

SECTION 4 MAINTENANCE

WARNING! Always turn off and disconnect power at control console AND at main supply circuit breaker before performing any service to the machine.

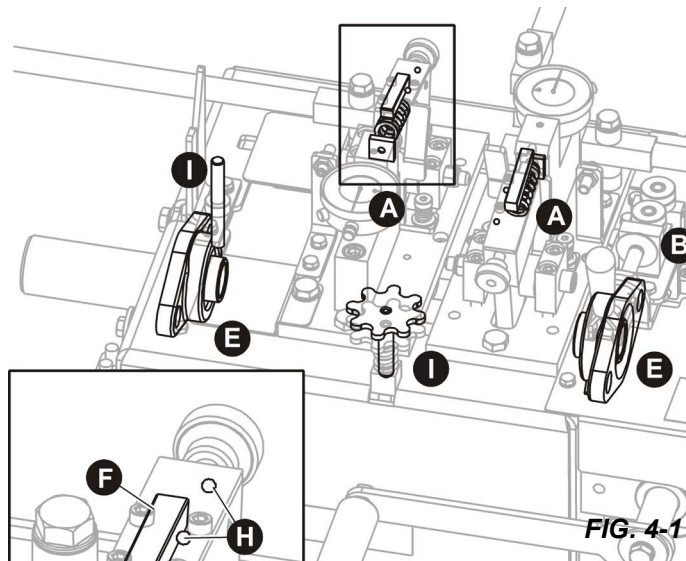

4.1 Routine Maintenance Schedule

Every 2 Weeks

Use compressed air to clean any debris from the setter assemblies (A) and blade clamp (B).

Apply NLGI No. 2 grade lithium grease to the ends of the die spring (C) of each setter assembly.

Every 3 Months

Lubricate the index arm pivot (D) and the feed shaft bearings (E). Apply NLGI No. 2 grade lithium grease to the grease fittings.

Check the setter blocks (F) and clamp pads (G) for wear. If the top edge of the clamp pad is worn, remove the mounting screw and rotate the pad 90° and replace the screw. When all four sides are worn, replace the pad. If the setter block is worn, regrind the block to 22° or replace.

Check adjustment knob tensions. The setter block and index arm backstop adjustment screws are secured with set screw/nylon ball mechanisms (H). These should be adjusted so the adjustment screws are held snugly, but still turn freely.

Check the blade height adjustment pins and knob (I) for wear and replace as necessary.

Clamp Adjustment

The clamp assembly is installed and properly adjusted at the factory. If it is necessary, use the adjustment set screw to readjust the clamp assembly as shown below.

The right end of the clamp mounting block should be 1/16" above the blade support plate.

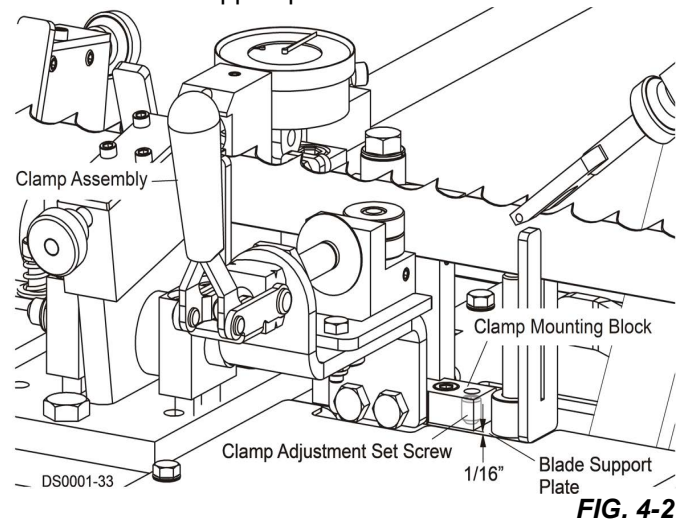

Gauge Assembly Adjustment

The gauge assemblies are installed and properly adjusted at the factory. If it is necessary, use the gauge strip to adjust the gauge assemblies as described below.

Pull the blade clamp lever open and flip the index arm up. Turn the feed handle counterclockwise (or push and hold the Auto Feed option START - JOG button) to advance the setter until the setter assemblies open.

Install the gauge strip in the setter assembly. Turn the feed handle counterclockwise (or push and hold the AUTO FEED option START - JOG button) to advance the setter until the setter assemblies start to close. Stop the setter when the setter assemblies are closed but the setter pusher does not contact the gauge strip. Make sure the gauge strip spacers are aligned with the gauge foot.

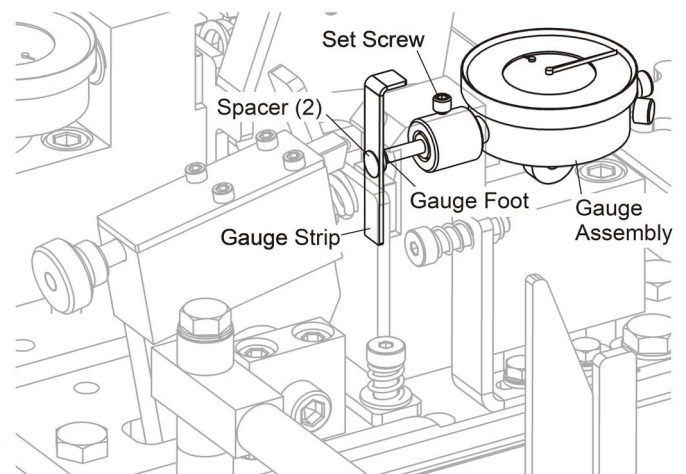

Loosen the set screw securing the gauge assembly to the setter assembly and pull the gauge assembly slightly out to remove any pressure on the gauge foot. Unlock the dial lock, adjust the setter gauge bezels to -.003 and lock the

dial lock. Reinstall the gauge assembly to the setter assembly so that the gauge foot touches the gauge strip spacer and the gauge needle reads 0. Tighten the set screw to secure the gauge assembly in place. Repeat the procedure for the other gauge assembly, if necessary. Install the blade to the toothsetter and perform the calibration procedure to make sure the gauge assemblies are adjusted properly ([See Section 3.2 Dual Setter Calibration](#)).

4.2 Safety Devices Inspection

Auto Feed Option Only (AC Only): Check the Emergency Stop (E-Stop) button for proper operation every shift.

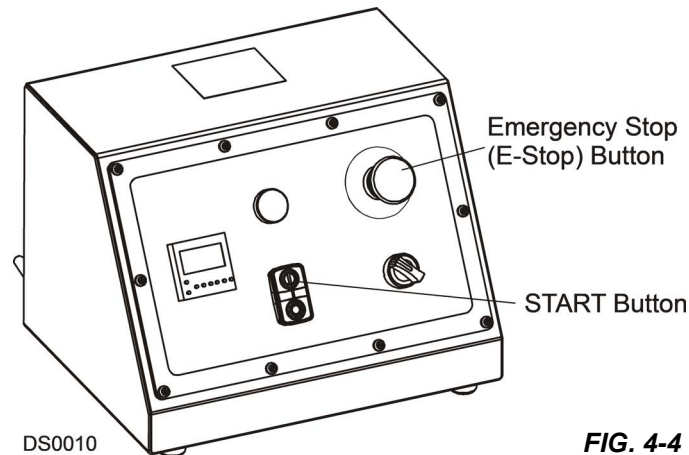

FIG. 4-4

The Emergency Stop (E-Stop) and START buttons as shown below.

To check the E-Stop button, toggle the power ON/OFF switch on the back of the control box to the ON (I) position. Press and hold the Start button to start the machine. Press the E-Stop button to shut down the machine. Before operating the machine again, turn the E-Stop button clockwise to release.

NOTE: The machine will not start until the E-Stop button is released.

SECTION 5 REPLACEMENT PARTS

5.1 Dual Toothsetter (Complete)

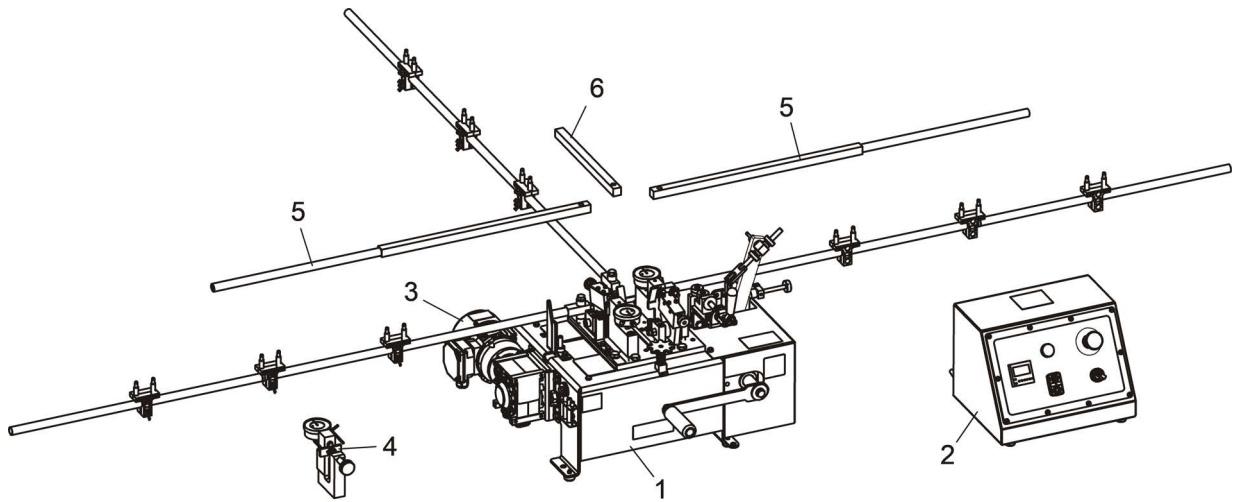

DS0001-1

REF	PART #	DESCRIPTION	COMMENTS	QTY.
1		DUAL TOOTHSETTER PARTS ()	See Section 5.2	
2		AC AUTO FEED CONTROL OPTION PARTS	See Section 5.10	
		DC AUTO FEED CONTROL OPTION PARTS	See Section 5.12	
3		AC AUTO FEED MOTOR OPTION PARTS	See Section 5.14	
		DC AUTO FEED MOTOR OPTION PARTS	See Section 5.15	
4		TOOTH SET MASTER GAUGE PARTS	See Section 5.16	
	061756	ARM KIT, LONG BLADE SUPPORT UPGRADE		1
5	060411	Arm, 36" Blade Support Extension		2
6	060412	Arm, 12" Blade Support Extension		1

5 Replacement Parts

Dual Toothsetter Assembly

5.2 Dual Toothsetter Assembly

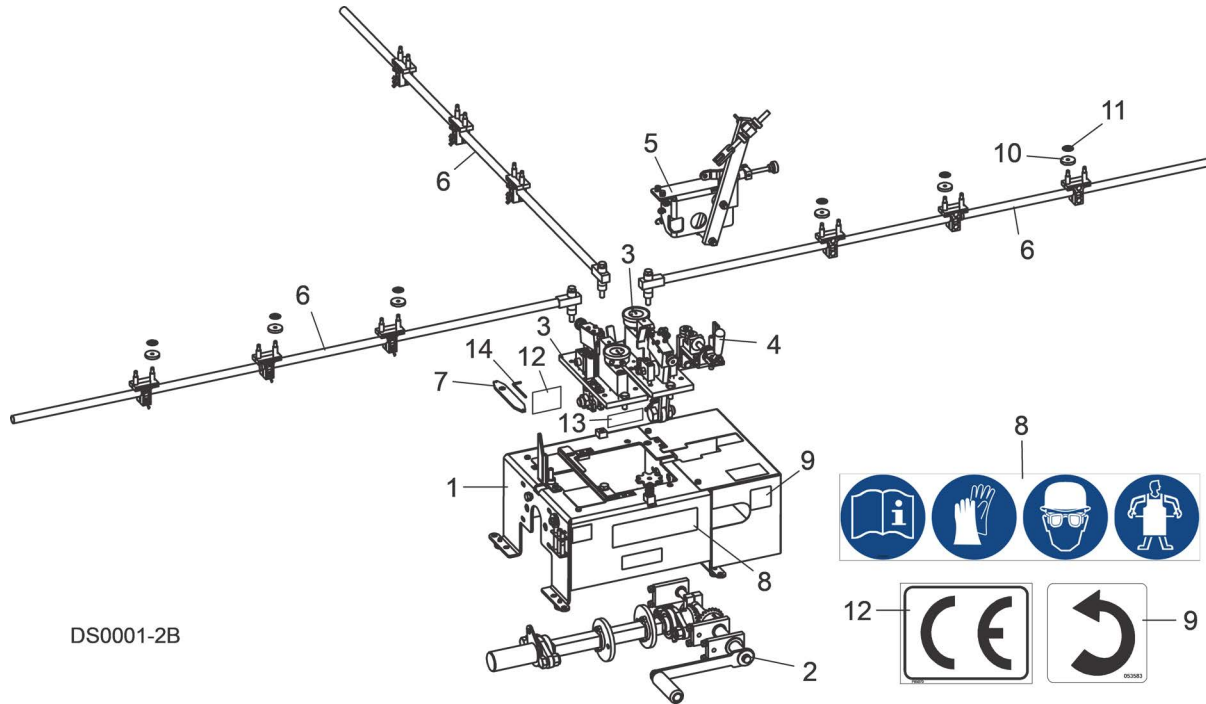

REF	PART #	DESCRIPTION	COMMENTS	QTY.
	066600	TOOTHSETTER ASSEMBLY, DUAL		1
1		Base Housing Parts	See Section 5.3	
2		Feed Drive Parts	See Section 5.4	
3		Blade Setter Parts	See Section 5.5	
4		Clamp Parts	See Section 5.7	
5		Index Parts	See Section 5.8	
6		Blade Support Arm Parts	See Section 5.9	
7	023774	Tool, Bend Back		1
8	069680	Decal Set, Universal Warning Pictorials		1
9	053583	Decal, Feed Direction		1
10	S10539	Wheel, Blade Support		6
11	F04254-54	Nut, 1/4" Dia Push		6
12	P85070	Decal, CE Certified Machine		1
13	016187	Decal, Revision		1
14	066759	Key, 3MM Hex		1
	M1792	MANUAL, DUAL TOOTHSETTER		1

5.3 Base Housing Assembly

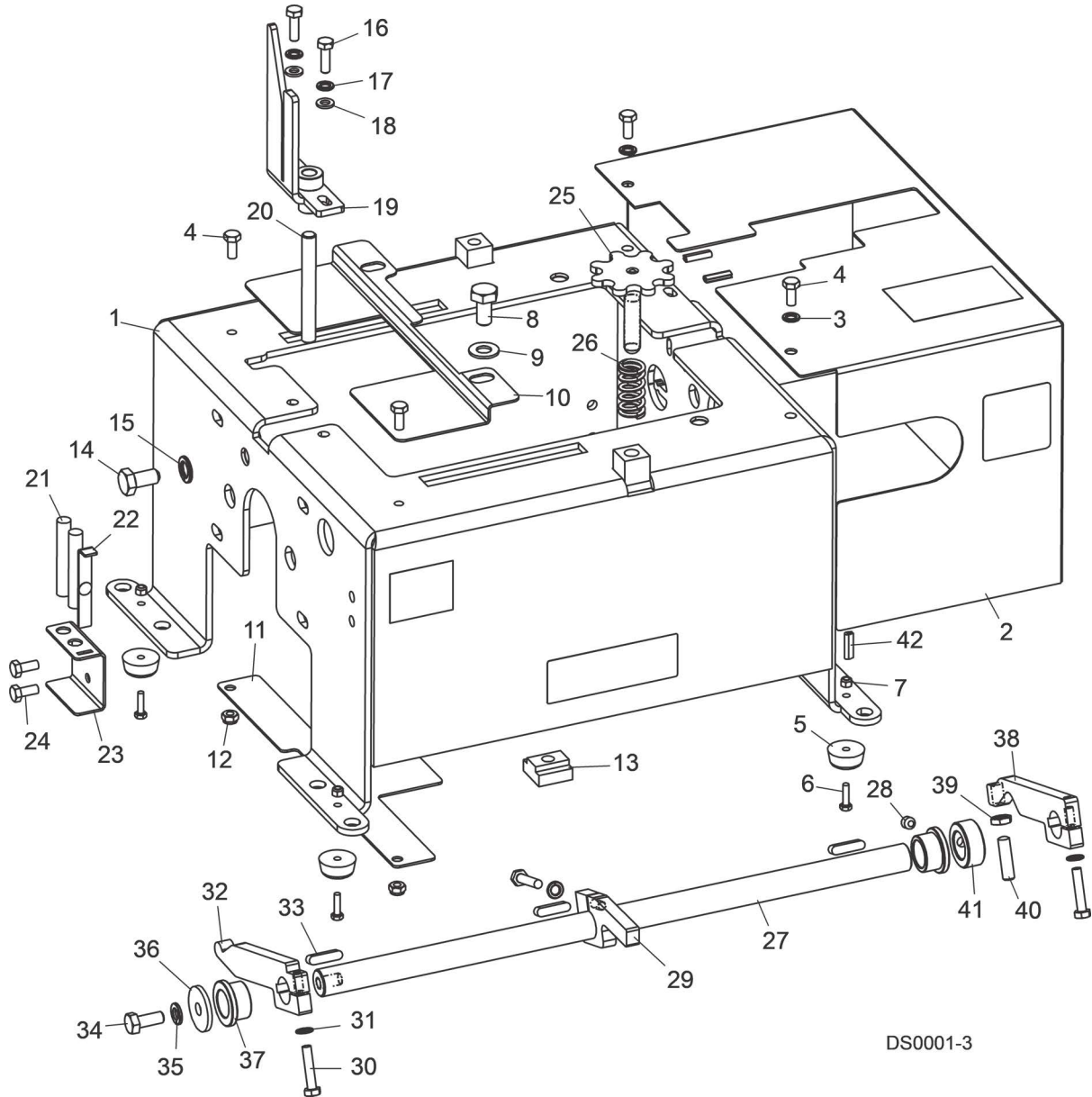

DS0001-3

REF	PART #	DESCRIPTION	COMMENTS	QTY.
1	066624	BASE WELDMENT, SETTER	Available in assemblies only.	1
2	066612	COVER, INDEX		1
3	F05026-2	WASHER, M6 SPLIT LOCK		2
4	F05020-7	BOLT, M6-1 X 14 HEX HEAD CLASS 8		4
5	P06104	FOOT, RUBBER		4
6	F05020-10	BOLT, M4-0.7 X 16 HEX HEAD CLASS 8		4

5

Replacement Parts

Base Housing Assembly

REF	PART #	DESCRIPTION	COMMENTS	QTY.
7	F05027-8	NUT, M4-0.7 X 16 HEX HEAD CLASS 8		4
8	F05022-2	BOLT, M10-1.5 X 20 HEX HEAD CLASS 8		1
9	F05011-3	WASHER, 3/8" SAE FLAT		1
10	066699	PLATE, UPPER GUARD		1
11	066698	PLATE, LOWER GUARD		1
12	F05010-200	NUT, M6-1.0 NYLON LOCK		2
13	066613	T-NUT, M10 X 1.5 STL		2
14	F05004-207	BOLT, M10-1.25 X 20MM HEX HEAD FULL THREAD 8.8		1
15	F05011-88	WASHER, 10MM SPLIT LOCK		1
	066606	GUIDE ASSEMBLY, OUTFEED		1
16	F05020-6	Bolt, M6-1 x 20 Hex Head Class 8		2
17	F05026-2	Washer, M6 Split Lock		2
18	F05026-1	Washer, M6 Flat Class 4		2
19	066653	Guide Weldment, Outfeed		1
20	F05012-130	Pin, 3/8' x 3 1/4" Dowel		1
	066700	HOLDER ASSEMBLY, SETTER PIN		1
21	F05012-106	Pin, 3/8" x 2 1/4" Hardened Dowel		2
22	066721	Gauge Assembly, Setter		1
23	066696	Holder, Pin		1
24	F05020-7	Bolt, M6-1 x 14 Hex Head Class 8		2
25	066660	ADJUSTER WELDMENT, BLADE HEIGHT		1
26	066677	SPRING, .72 OD X 1.50 LGH X .105 WIRE		1
	066638	BLADE HEIGHT ADJUSTER, DUAL SETTER		1
27	066642	Shaft, Blade Adjuster		1
28	F05021-8	Screw, M8-1.25 x 8 SH Cup Set		1
29	066644	Arm, Adjuster		1
30	F05020-8	Bolt, M6-1 x 30 Hex Head Class 8		3
31	F05026-2	Washer, M6 Split Lock		3
32	066655	Arm, Blade Height		1
33	076051	Key, 6x6x25mm	066671 removed (ECN: 37675)	3
34	F05021-2	Bolt, M8-1.25 x 20 Hex Head Class 8		1
35	F05011-45	Washer, 8mm Split Lock		1
36	F05011-105	Washer, 5/16" x 1 1/4" x 1/8"		1
37	P786	Bushing, 3/4" ID x 1" OD x 5/8" Long Flanged		2
38	066643	Arm, Blade Height Adjustable		1
39	F05010-76	Nut, M8 x 1.25 Metric Jam		1
40	F05021-22	Screw, M8-1.25 x30mm SHOP Set		1
41	066673	Collar, 3/4" ID x 1 1/4" OD x 1/2" Long Metric		1
42	074827	EXTRUSION, RUBBER ISOLATOR		4

5.4 Feed Drive Assembly

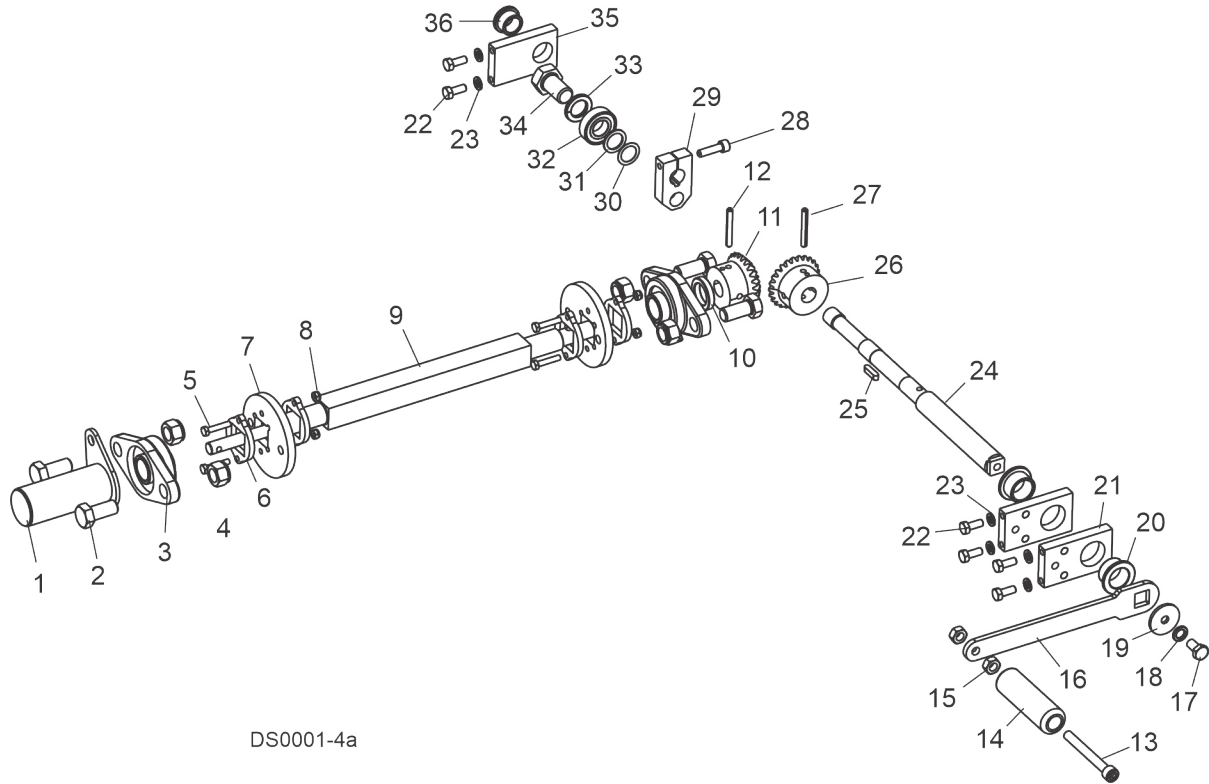

DS0001-4a

REF	PART #	DESCRIPTION	COMMENTS	QTY.
1	060524	COVER WELDMENT, SHAFT		1
	066620	CAM DRIVE ASSEMBLY, DUAL SETTER		1
2	F05025-2	Bolt, M16-2 x 35 Hex Head		4
3	089124	Bearing, 25mm Bore 2 Bolt Flange		2
4	F05027-6	Nut, M16-2 Nylon Lock Class 8		4
	066674	Cam Assembly, Dual Setter		2
5	F05020-8	Bolt, M6-1 x 30 Hex Head Class 8		2
6	066623	Plate, Cam Support		2
7	066628	Plate, Cam		1
8	F05010-200	Nut, M6-1.0 Nylon Lock		2
9	066607	Shaft, Dual Setter		1
10	060545	Spacer, Bearing		1
11	060565	Gear, 10 Pitch x 2.5 Pitch Dia x 3/4"		1
12	F05029-8	Pin, 6mm x 50mm Roll		1
	066605	INDEX SHAFT ASSEMBLY, DUAL SETTER		1
	066676	Handle Assembly, Dual Setter		1
13	F05022-6	Bolt, M10-1.5 x 90 SHC		1
14	066675	Handle, 13/32" ID x 1 1/4" OD x 4" Plastic		1

5

Replacement Parts*Feed Drive Assembly*

REF	PART #	DESCRIPTION	COMMENTS	QTY.
15	F05010-85	Nut, M10-1.5 Hex		2
16	060562	Arm, Feed Crank		1
17	F05004-207	Bolt, M10-1.25 x 20mm Hex Head Full Thread 8.8		1
18	F05011-88	Washer, 10mm Split Lock		1
19	F05011-104	Washer, 3/8" ID x 1 1/2" OD x 1/8" THK Hardened		1
20	P737	Bushing, 1" ID x 1 1/4" OD x 3/4" Flanged Bronze		2
21	066622	Block, Shaft		2
22	F05021-2	Bolt, M8-1.25 x 20 Hex Head Class 8		6
23	F05011-45	Washer, 8mm Split Lock		6
24	066621	Shaft, Index		1
25	076051	Key, 6x6x25mm		1
26	060565	Gear, 10 Pitch x 2.5 Pitch Dia x 3/4"		1
27	F05029-8	Pin, 6mm x 50mm Roll		1
28	F05021-1	Screw, M8-1.25 x 30 SHC		1
29	066614	Block, Cam		1
30	066626	Washer, 20mm x 28mm x 3mm Spring Shim		1
31	066722	Spacer, 16mm Bearing		1
32	057442	Bearing, 6004-2RS		1
33	F05026-3	Washer, M20 Split Lock		1
34	F05025-1	Bolt, M20-2.5 x 35 Hex Head Class 8		1
35	066656	Block, Shaft		1
36	P786	Bushing, 3/4" ID x 1" OD x 5/8" Long Flanged		1

5.5 Blade Setters

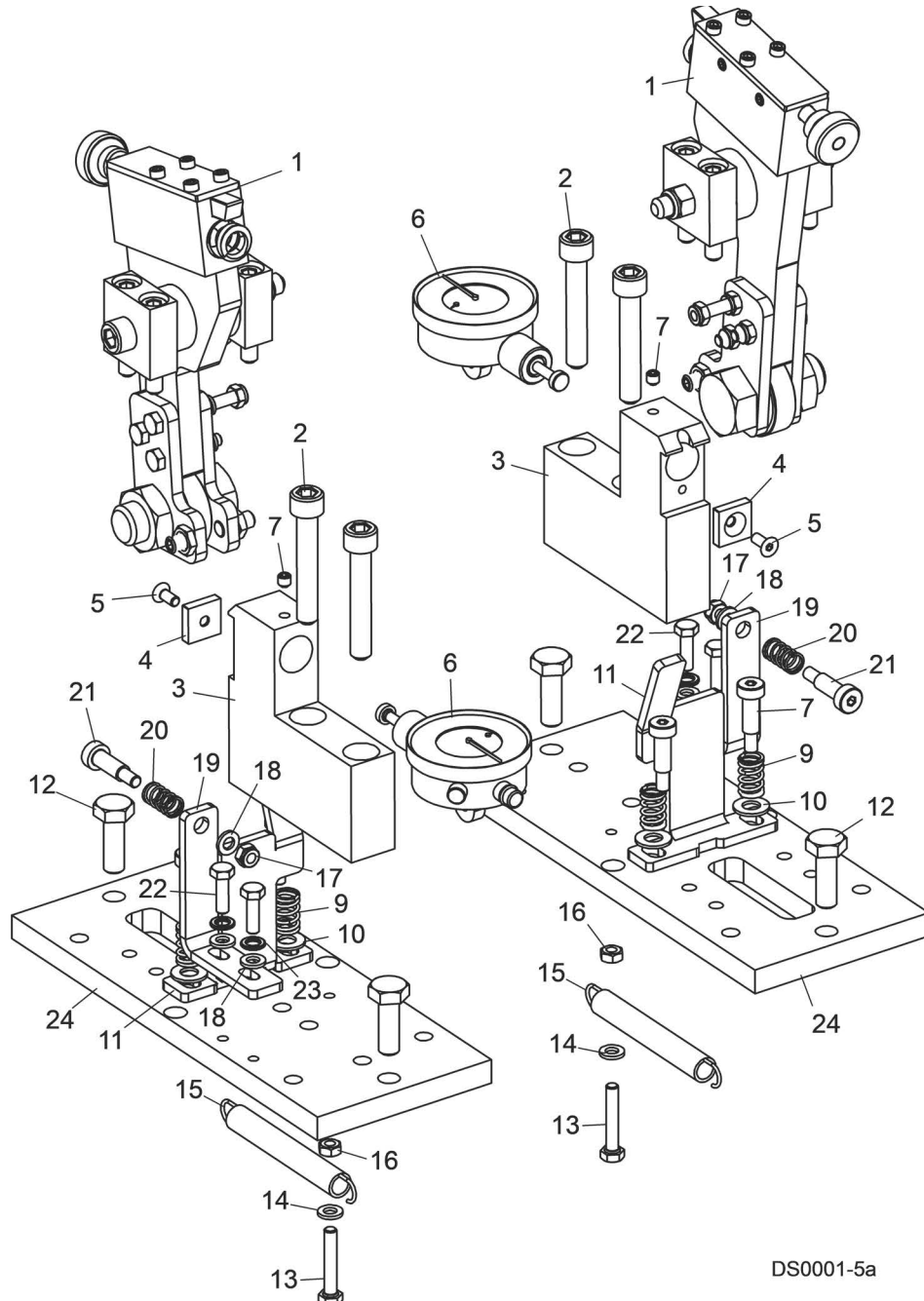

DS0001-5a

REF	PART #	DESCRIPTION	COMMENTS	QTY.
	066633	SET ASSEMBLY, DUAL BLADE		2
1		Blade Set Arm Parts	See Section 5.6	
	066716	Block Assembly, Setter Back		1

5

Replacement Parts

Blade Setters

REF	PART #	DESCRIPTION	COMMENTS	QTY.
2	F05022-5	Bolt, M10-1.5 x 60 Socket Head		2
3	066715	Block, Rear Set		1
4	066609	Insert, Setter Clamping Metric		1
5	F05020-11	Screw, M5- .8 x 12 Flat Head SHC		1
6	061771	Gauge Assembly, Toothsetter		1
7	F05020-5	Screw, M6-1 x 6 SH Cup Pt Set		1
8	F05021-4	Bolt, 8mm x 20mm Socket Head Shoulder Plain		2
9	060539	Spring, .48" OD x 3/4" Long x .063" Wire Compression		2
10	F05011-17	Washer, 5/16" SAE Flat		2
11	130119	Plate, Setter Clamp	ECN:36117. Was 060587.	1
12	F05022-3	Bolt, M10-1.5 x 30 Hex Head Class 8		2
13	F05020-9	Screw, M6-1 x 35 Hex Head Class 8		1
14	F05026-1	Washer, M6 Flat Class 4		1
15	P08848	Spring, LE-063E-8MW		1
16	F81031-1	Nut, M6-1.0 Free Nut		1
	066667	Blade Guide, Setter		2
17	F05010-200	Nut, M6-1.0 Nylon Lock		1
18	F05026-1	Washer, M6 Flat Class 4		3
19	066664	Plate, Wear Pin		1
20	P32011	Spring, .75 LTH Compression		1
21	F05021-4	Bolt, 8MM x 20MM SH Shoulder Plain		1
22	F05020-6	Bolt, M6-1 x 20 Hex Head Class 8		2
23	F05026-2	Washer, M6 Split Lock		2
24	066634	Plate, Blade Setter Base	Available in assemblies only.	1

5.6 Blade Set Arm Assembly

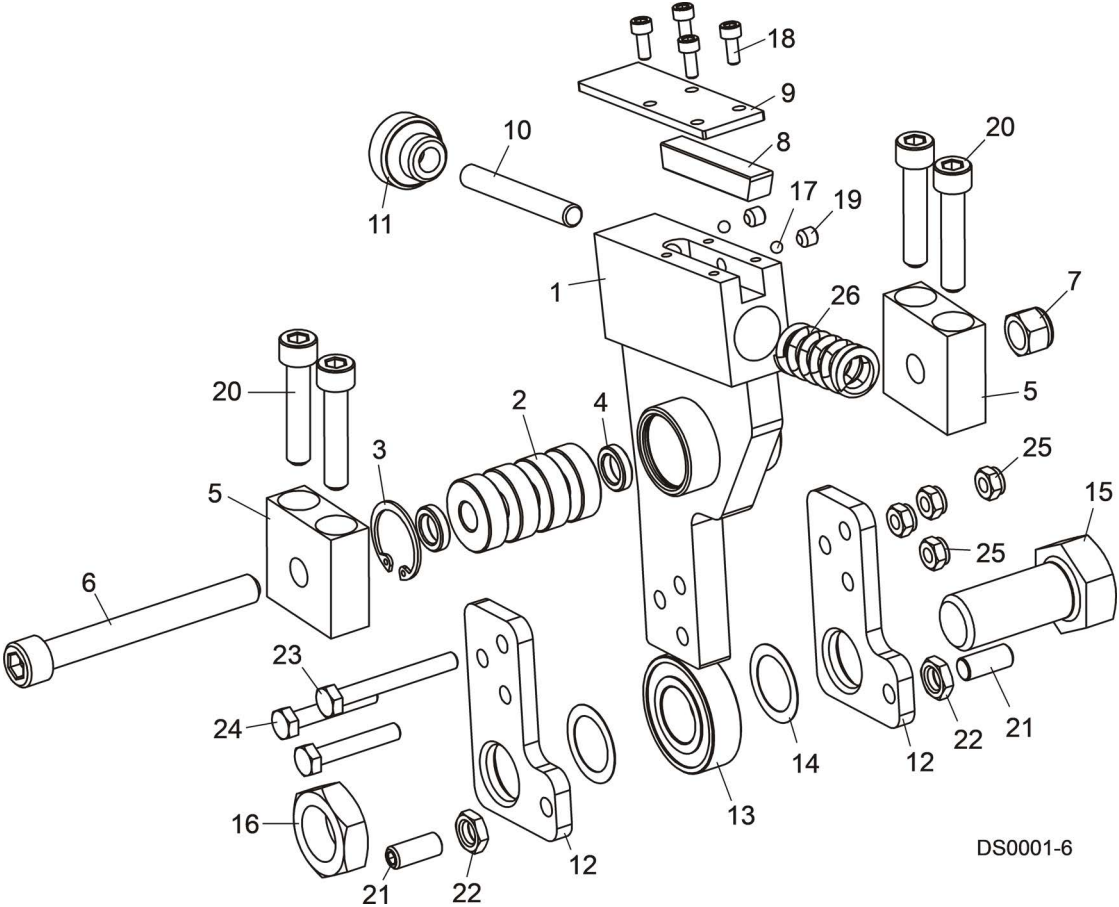

DS0001-6

REF	PART #	DESCRIPTION	COMMENTS	QTY.
	066631	ARM ASSEMBLY, TOOTH SETTER		2
1	066632	Arm Weldment, Setter		1
2	087471	Bearing, 6000-2RSR 10mm Bore		4
3	F05028-2	Ring, 26mm Internal Retaining		1
4	066641	Spacer, Bearing		2
5	066640	Block, Pivot		2
6	F05022-6	Screw, M10-1.5 x 60 Socket Head		1
7	F05004-270	Nut, M10-1.50 Hex Nylon Lock		1
8	060597	Pusher, Blade Setter		1
9	066630	Plate, Setter Pusher Top		1
	060583	Pin Assembly, Setter Pusher		1
10	060584	Rod, 5/16-24 x 2 3/8" Threaded		1
11	060573	Knob, Knurled Pusher Pin		1
12	066629	Plate, Setter Arm Cam		2

5**Replacement Parts**
Blade Set Arm Assembly

REF	PART #	DESCRIPTION	COMMENTS	QTY.
13	057442	Bearing, 6004-2RS		1
14	066626	Washer, 20mm x 28mm x 0.3mm Spring		2
15	F05025-3	Bolt, M20-2.5 x 45 Hex Head Class 8		1
16	F05027-9	Nut, M20-2.5 Hex Jam		1
17	060549	Ball, 3/16" Dia. High-Impact Polystyrene		2
18	F05020-14	Screw, M4-0.7 x 10 Socket Head		4
19	F05020-5	Screw, M6-1 x 6 Socket Head Cup Point Set		2
20	F05021-6	Screw, M8-1.25 x 40 Socket Head		4
21	F05021-7	Screw, M8-1.25 x 20 Socket Head Point Set		2
22	F05010-76	Nut, M8 x 1.25 Hex Jam Metric		2
23	F05020-4	Bolt, M6-1 x 50 Hex Head Class 8		1
24	F05020-9	Bolt, M6-1 x 35 Hex Head Class 8		2
25	F05010-200	Nut, M6-1.0 Hex Nylon Lock		4
26	060499	Spring, 3/4" OD x 1 1/2" Long x .165" x .125" WI		1

5.7 Clamp Assembly

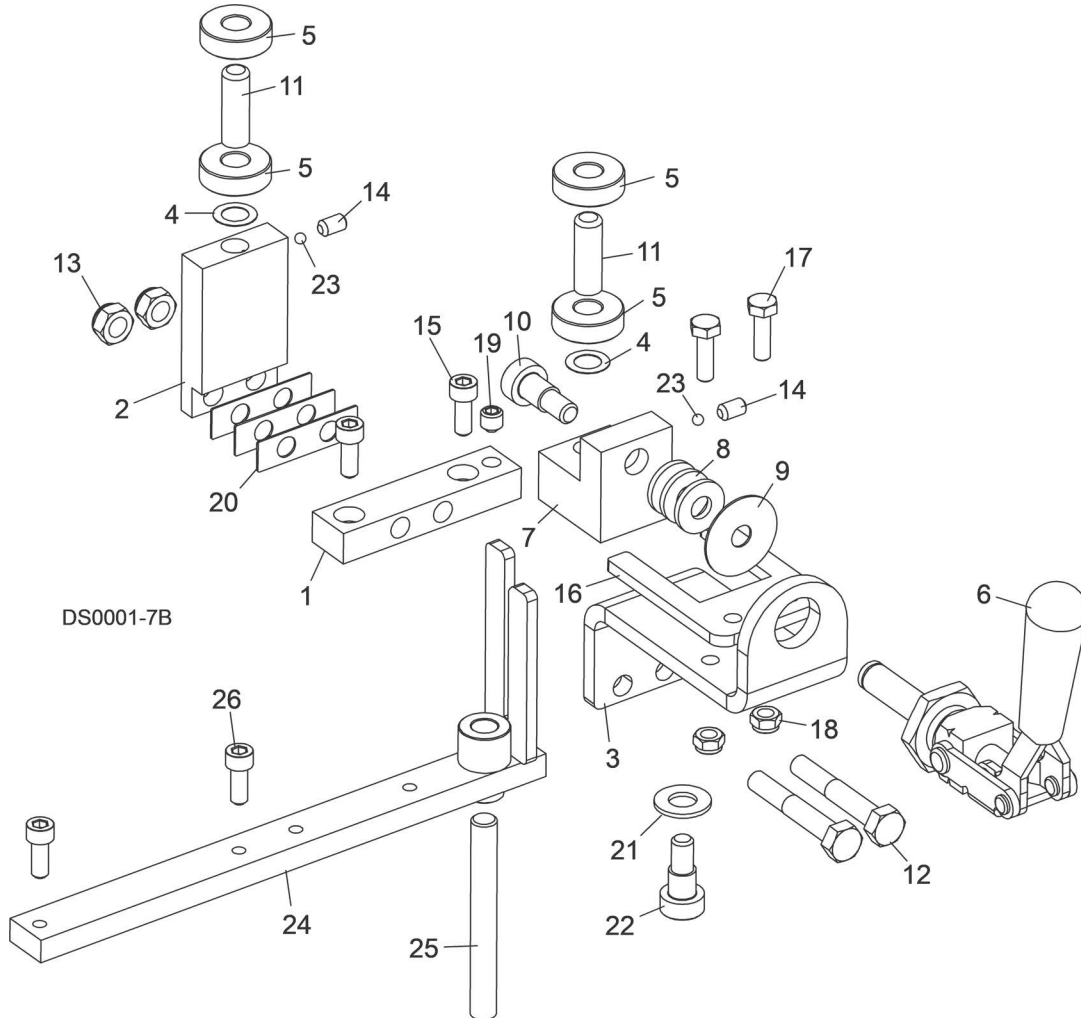

REF	PART #	DESCRIPTION	COMMENTS	QTY.
	066649	GUIDE ASSEMBLY, DUAL SETTER INFEED		1
	066705	Clamp Assembly, Dual Setter		1
1	066712	Block, Clamp Mounting		1
2	066711	Plate, Clamp Bearing		1
3	066710	Plate, Clamp Handle Support		1
4	066707	Spacer, .03mm Shim		2
5	087471	Bearing, 6000-2RSR 10mm Bore		4
6	066701	Clamp Handle, Dual Setter		1
7	066709	Block, Clamp Bearing		1
8	060531	Washer, 3/8" ID x 13/16" OD x .093" Rubber		3
9	F05011-50	Washer, 5/16" ID x 1 1/4" OD Fender		1

5

Replacement Parts*Clamp Assembly*

REF	PART #	DESCRIPTION	COMMENTS	QTY.
10	F05022-10	Bolt, 10mm x 10mm Socket Head Shoulder Plain		1
11	F05029-9	Pin, 10mm x 30mm Hardened Dowel		2
12	F81002-10	Bolt, M8 x 50 Hex Head		2
13	F05010-132	Nut, M8 Hex Nylon Lock		2
14	F05020-16	Screw, M6-1 x 10 Socket Head Cup Point Set		2
15	F05004-206	Screw, M6-1 x 16 Socket Head		2
16	066708	Plate, Setter Clamp Guide		1
17	F05020-6	Bolt, M6-1 x 20 Hex Head Class 8		2
18	F05010-200	Nut, M6-1.0 Hex Nylon Lock		2
19	F05021-8	Screw, M8-1.25 x 8 Socket Head Cup Point Set		1
20	066706	Plate, Shim		3
21	F05011-3	Washer, 3/8" SAE Flat		1
22	F05022-9	Bolt, 10mm x 10mm Socket Head Shoulder Plain		1
23	060549	Ball, 3/16 High-Impact Polystyrene		2
24	066648	Guide Weldment, Infeed		1
	107399	Guide Weldment, Infeed, Narrow Band	Optional. For use with (1") blades.	1
25	F05012-130	Pin, 3/8" x 3 1/4" Dowel		1
26	F05004-206	Screw, M6-1 x 16 Socket Head		2

5.8 Index Assembly

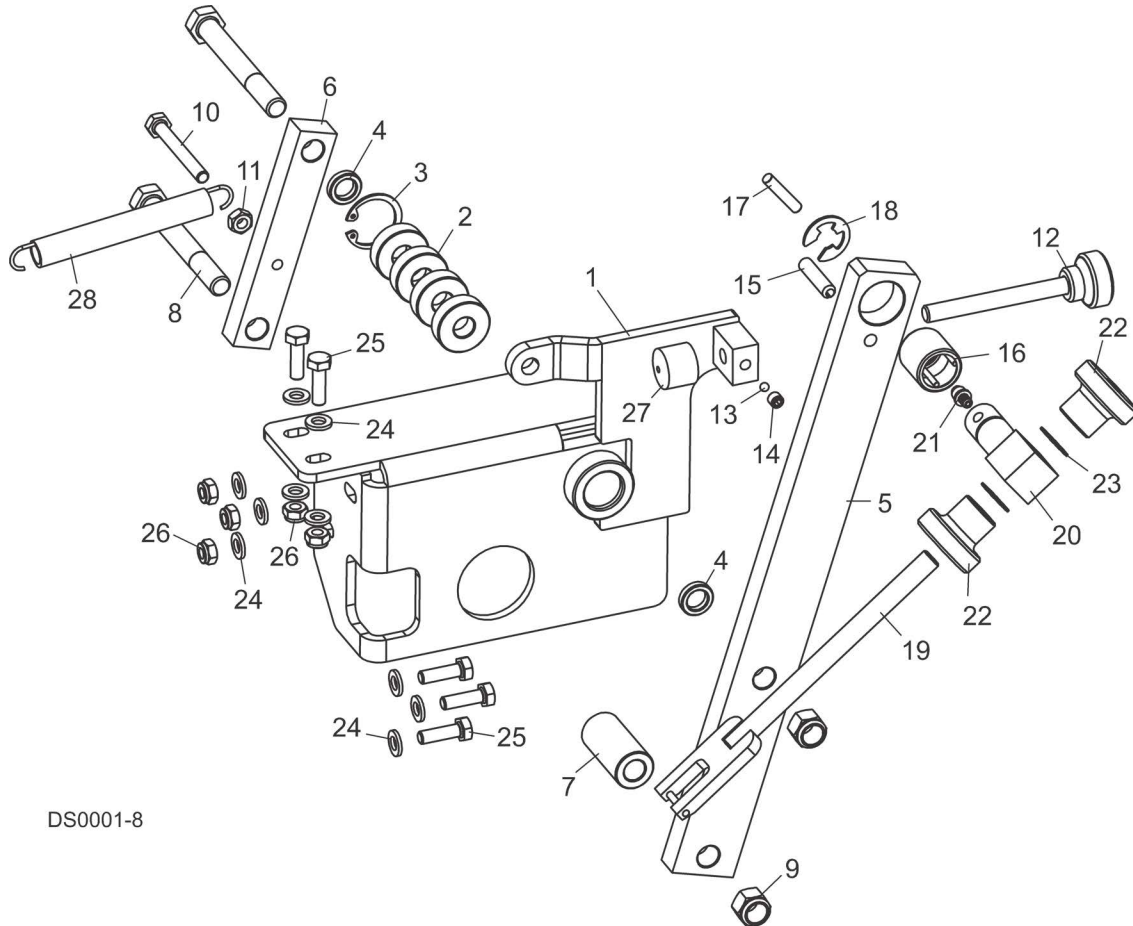

DS0001-8

REF	PART #	DESCRIPTION	COMMENTS	QTY.
	066608	INDEX ASSEMBLY, DUAL SETTER		1
1	066618	Index Weldment, Dual Setter		1
2	087471	Bearing, 6000-2RSR 10mm Bore		4
3	F05028-2	Ring, 26mm Internal Retaining		1
4	066641	Spacer, Bearing		2
5	066617	Arm, Setter Index		1
6	066616	Arm, Setter Index Wear		1
7	066615	Spacer, Index Arm		1
8	F05022-1	Bolt, M10-1.5 x 80 Hex Head Class 8		2
9	F05004-270	Nut, M10-1.50 Hex Nylon Lock		2
10	F05020-4	Bolt, M6-1 x 50 Hex Head Full Thread Class 8		1
11	F81031-1	Nut, M6-1.0 Free Hex		1
12	066719	Adjuster Assembly, Index		1
13	060549	Ball, 3/16" Dia. High-Impact Polystyrene		1

5

Replacement Parts*Index Assembly*

REF	PART #	DESCRIPTION	COMMENTS	QTY.
14	F05020-5	Screw, M6-1 x 6 Socket Head Cup Point Set		1
15	F05029-6	Pin, 6mm x 30mm Roll		1
16	066668	Bearing 16mm ID x 22 OD x 22mm ID Needle Roller		1
	066602	Pawl Assembly, Setter Push		1
17	F05029-7	Pin, 5mm x 24mm Dowel		1
18	F05028-1	Clip, 12mm ID "E"		1
19	053309	Pawl Weldment, Setter Index		1
20	066601	Shaft, Index Pivot		1
21	P04107	Fitting, 3/6" x 3/16" Straight Grease		1
22	066702	Knob, Knurled 1-5/16" OD		2
23	F05011-36	Washer, 3/8" Star External		2
24	F05026-1	Washer, M6 Flat Class 4		10
25	F05020-6	Bolt, M6-1 x 20 Hex Head Class 8		5
26	F05010-200	Nut, M6-1.0 Hex Nylon Lock		5
27	060529	Bumper, 3/4" OD x 5/16-24 Threaded Rubber		1
28	P08848	Spring, LE-063E-8MW		1

5.9 Blade Support Arm Assembly

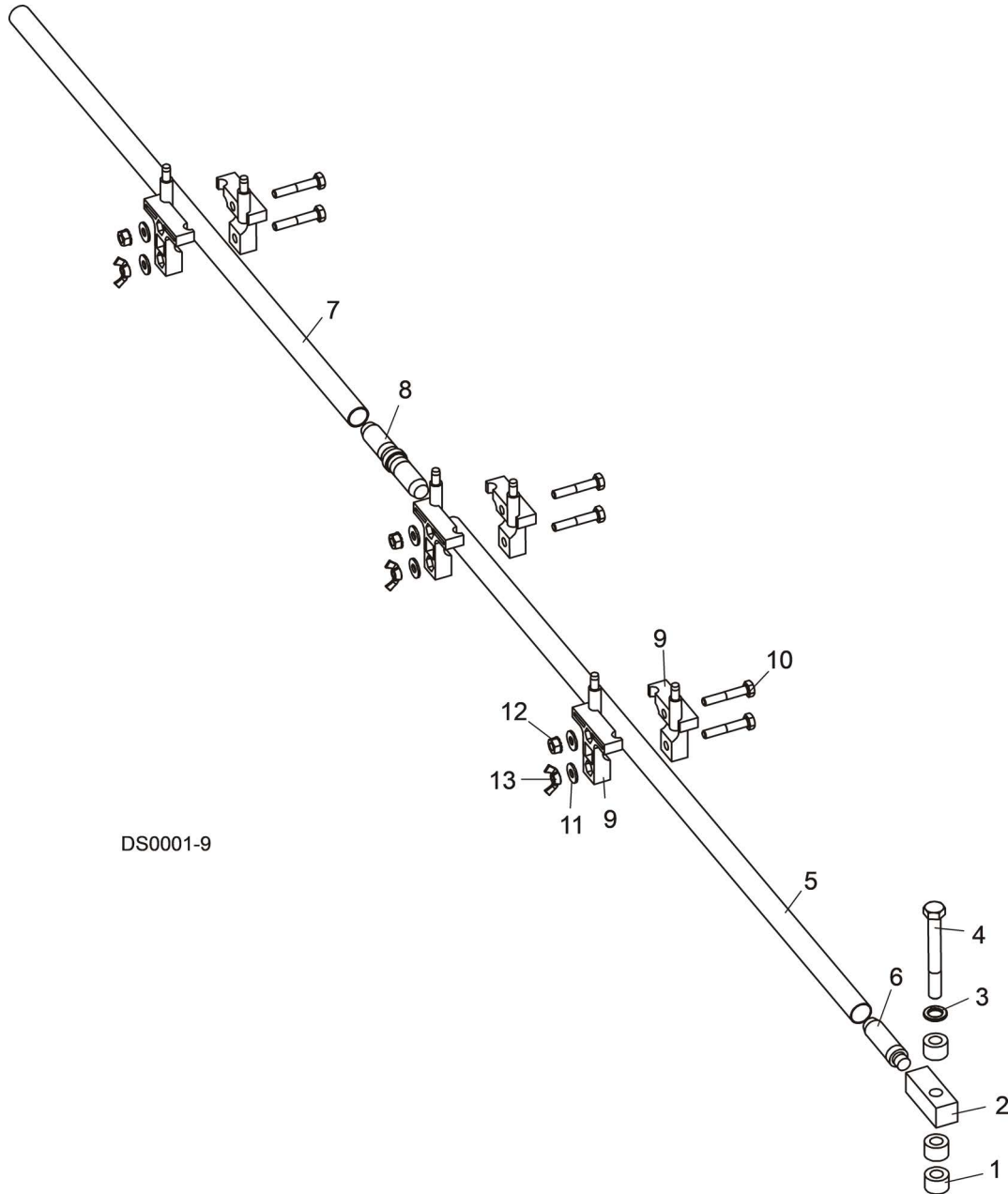

DS0001-9

REF	PART #	DESCRIPTION	COMMENTS	QTY.
	066603	ARM ASSEMBLY, BLADE SUPPORT		3
1	066678	Spacer, 13/32" ID x 3/4" OD 1/2" Long		3
2	035777	Block, Blade Support Arm Mount		1
3	F05011-88	Washer, 10mm Split Lock		1
4	F05022-1	Bolt, M10-1.5 x 80 Hex Head Class 8		1

5**Replacement Parts***Blade Support Arm Assembly*

REF	PART #	DESCRIPTION	COMMENTS	QTY.
	A04550	Tube Assembly, Blade Support		1
5	M04551	Tube, Blade Support		1
6	P04552	Plug, Support Tube		1
	060035	Tube Assembly, Blade Support Extension		1
7	060033	Tube, Blade Support Extension		1
8	060034	Plug, Support Extension Tube		1
	A30008	Guide Assembly, Blade Support		3
9	S10611	Guide, Blade Support w/Post		2
10	F05005-5	Bolt, 1/4-20 x 1 1/2" Hex Head		2
11	F05011-11	Washer, 1/4" SAE Flat		2
12	F05010-9	Nut, 1/4-20 Hex Self-Locking		1
13	F05010-13	Nut, 1/4-20 Wing		1

5.10 Auto Feed Control, AC 120V (Optional)

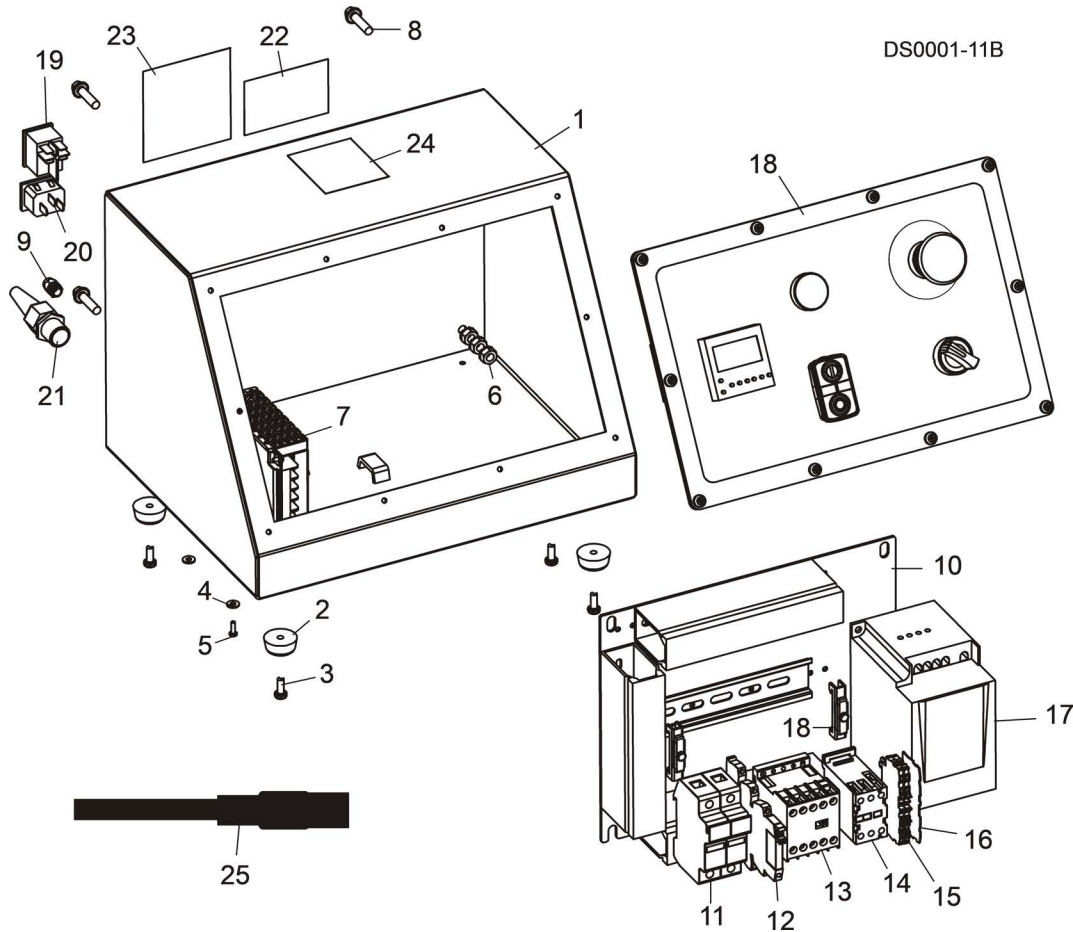

REF	PART #	DESCRIPTION	COMMENTS	QTY.
	066684-120	BOX ASSEMBLY, AC DUAL SETTER 120V CONTROL (U.S.)		1
1	066687	Box Weldment, AC Dual Toothsetter Control		1
2	P06104	Foot, Rubber		4
3	F05015-17	Bolt, #10-24 x 1/2" Slotted Hex Head Self-Tapping		4
4	F05011-56	Washer, #6 SAE Flat		2
5	F05020-17	Screw, M3 x .5 x 10mm Round Head		1
6	F05010-9	Nut, 1/4-20 Keps		6
7	068314	Power Supply, 24VDC 1.1A 25W		1
8	F05005-136	Screw, 1/4-20 x 1 Head Flange		2
9	066697	Receptacle, M8 3P Female		1
	066694	Panel Assembly, AC Dual Setter 120VAC Insert		1
10	066693	Insert Panel, Setter Control Box		1

5

Replacement Parts

Auto Feed Control, AC 120V (Optional)

REF	PART #	DESCRIPTION	COMMENTS	QTY.
11	052731	Fuseholder, 1P Class CC Finger Safe		2
	069664	Fuse, 15A Class CC Fast Acting		1
	052446	Fuse, 2A 600V KLDR Class CC		1
12	052911	Relay, 6A 24VDC w/Screw Terminal Socket		1
13	101241	Contact, 9A 3P 24VDC K-Series		1
14	051684	Relay, IEC Control 2 NO 24VDC		1
15	068104	Terminal Block, 4 Pos. 2.5mm GND Clamp		2
16	068105	Terminal Block, 4 Pos. 2.5mm End Plate		1
17	069683	Drive Assembly, 120V AC Dual Setter Feed		1
	069692	Cable Assembly, AC Dual Setter Motor Drive		1
18		Dual Setter Control Panel Parts	See Section 5.13	
19	060515	Switch, On/Off Rocker		1
20	060216	Receptacle, Power Entry		1
21	060507	Strain Relief, 3/8" NPT .15-.32" Flex		1
22	069681	Decal, Electrical Hazard/Unplug Warning		1
23	069675	Decal, 115V AC Dual Setter Electrical Info		1
24	069685	Decal, Read Owner's Manual Warning		1
25	069666	POWER CORD, 5-15P TO IEC C-13 15A		1
	069667	CABLE, M8 3P 2M MALE/FEMALE STRAIGHT/90		1
	052291	PROX SENSOR, 8MM PNP SHIELDED QD RSHP		1
	F05089-3	TIE WRAP, 3/16" X 6" UV BLACK		4

5.11 Auto Feed Control, AC 220V (Optional)

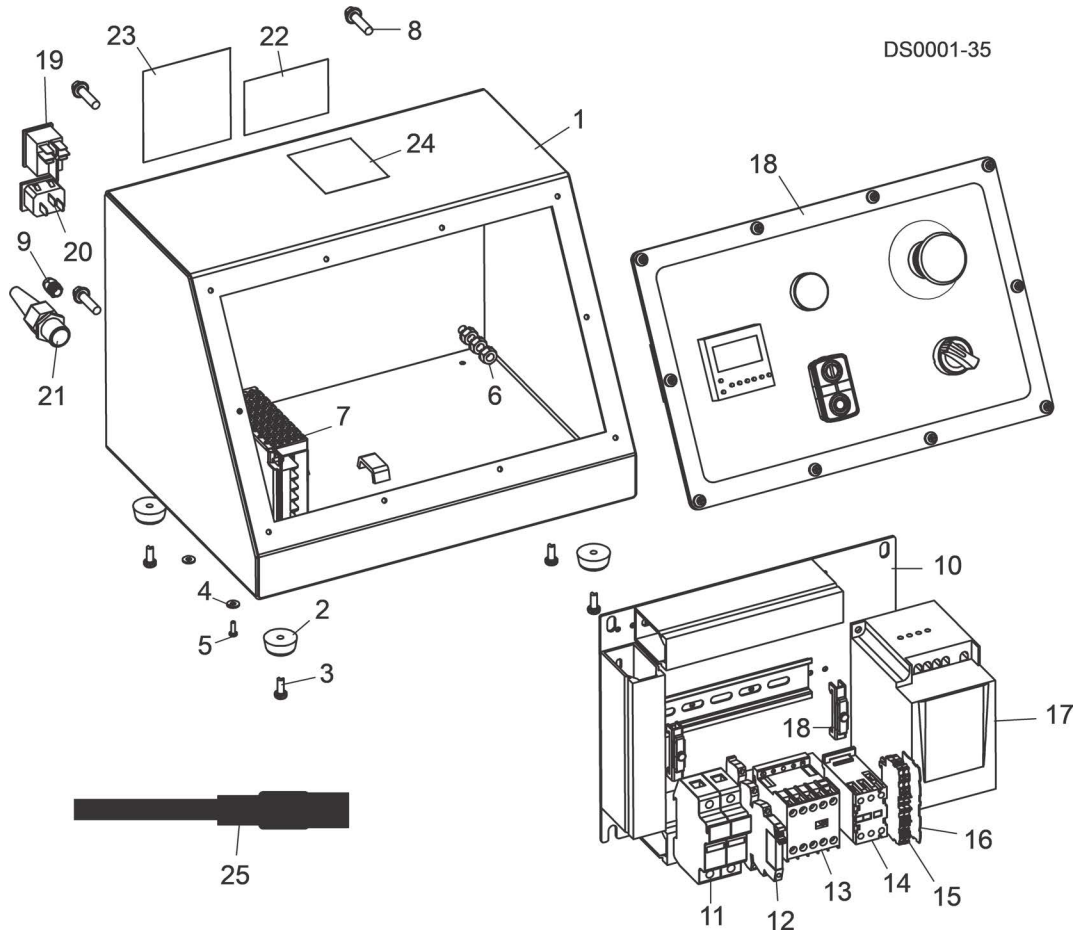

REF	PART #	DESCRIPTION	COMMENTS	QTY.
	066684-220	BOX ASSEMBLY, AC DUAL SETTER 220V CONTROL (CE)		1
1	066687	Box Weldment, AC Dual Toothsetter Control		1
2	P06104	Foot, Rubber		4
3	F05015-17	Bolt, #10-24 x 1/2" Slotted Hex Head Self-Tapping		4
4	F05011-56	Washer, #6 SAE Flat		2
5	F05020-17	Screw, M3 x .5 x 10mm Round Head		1
6	F05010-9	Nut, 1/4-20 Keps		6
7	068314	Power Supply, 24VDC 1.1A 25W		1
8	F05005-136	Screw, 1/4-20 x 1 Head Flange		2
9	066697	Receptacle, M8 3P Female		1
	069673	Panel Assembly, AC Dual Setter 220V Insert		1
10	066693	Insert Panel, Setter Control Box		1

5

Replacement Parts

Auto Feed Control, AC 220V (Optional)

REF	PART #	DESCRIPTION	COMMENTS	QTY.
11	068313	Breaker, 4A Curve C C60N		1
	069670	Breaker, 1P 1A Multi 9 C-Trip Curve		1
12	052911	Relay, 6A 24VDC w/Screw Terminal Socket		1
13	101241	Contact, 9A 3P 24VDC K-Series		1
14	051684	Relay, IEC Control 2 NO 24VDC		1
15	068104	Terminal Block, 4 Pos. 2.5mm GND Clamp		2
16	068105	Terminal Block, 4 Pos. 2.5mm End Plate		1
17	069684	Drive Assembly, 220V AC Dual Setter Feed		1
	069692	Cable Assembly, AC Dual Setter Motor Drive		1
18		AC Dual Setter Control Panel Parts (See Section 5.13)		
19	060515	Switch, On/Off Rocker		1
20	060216	Receptacle, Power Entry		1
21	060507	Strain Relief, 3/8" NPT .15-.32" Flex		1
22	069681	Decal, Electrical Hazard/Unplug Warning		1
23	069676	Decal, 220V AC Dual Setter Electrical Info		1
24	069685	Decal, Read Owner's Manual Warning		1
25	069672	POWER CORD, SCHUKO TO IEC C7 16A		1
	069667	CABLE, M8 3P 2M MALE/FEMALE STRAIGHT/90		1
	052291	PROX SENSOR, 8MM PNP SHIELDED QD RSHP		1
	F05089-3	TIE WRAP, 3/16" X 6" UV BLACK		4

5.12 Auto Feed Control, DC (Optional)

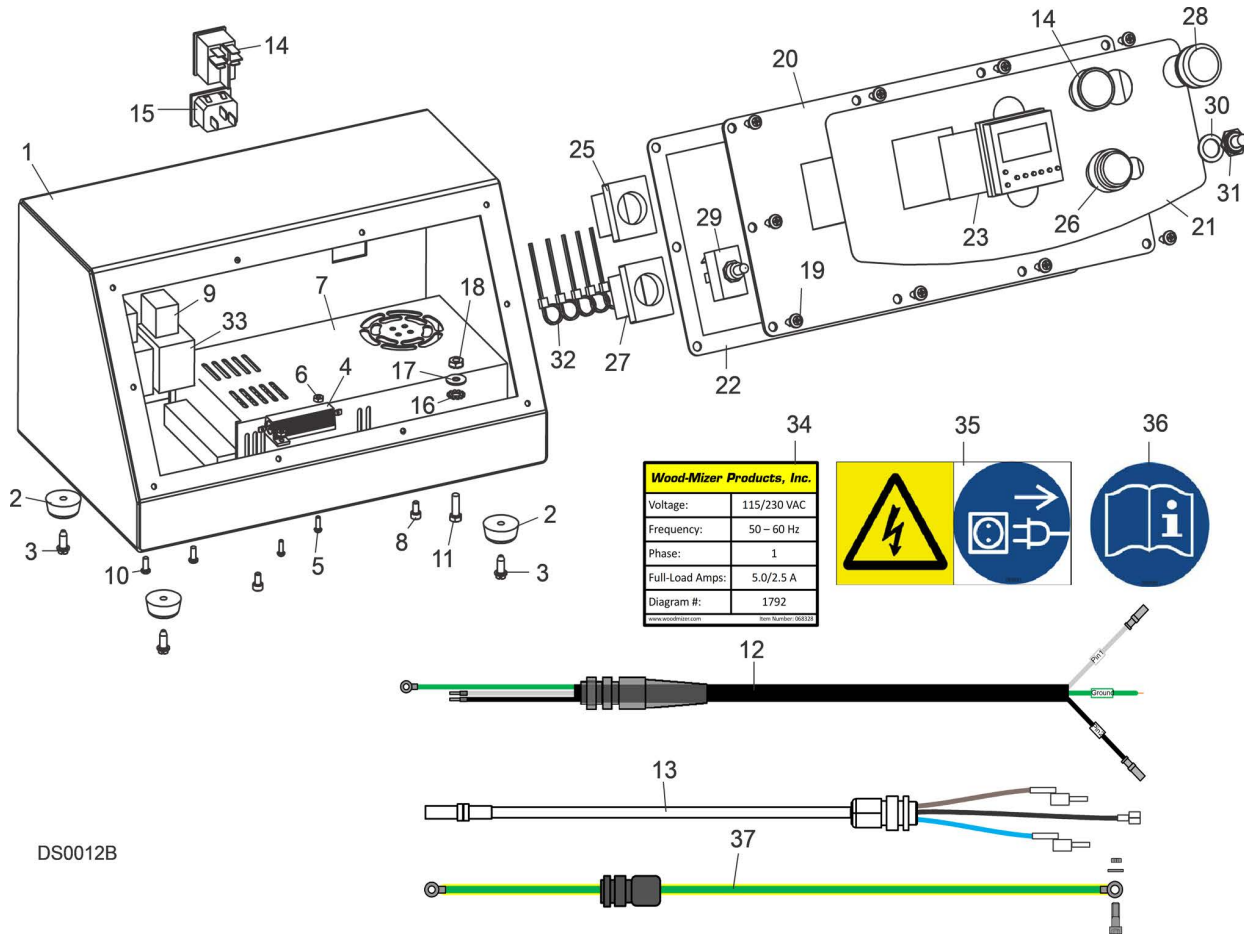

REF	PART #	DESCRIPTION	COMMENTS	QTY.
	068324	BOX ASSEMBLY, AUTO FEED CONTROL (DC ONLY)		1
1	066950	Box Weldment, Setter Control		1
2	P06104	Foot, Rubber		4
3	F05015-18	Bolt, #8-32 x 1/2" Slotted Hex Head Self-Tapping		4
	068327	Resistor Assembly, BMT250DC Motor		1
4	060498	Resistor, 1 Ohm 50W Power		1
5	F05004-9	Screw, #4-40 x 3/8" Slotted Round Head		2
6	F05010-43	Nut, #4-40 Hex		2
7	060519	Power Supply, 85/264VAC 24VDC 500W	For customers replacing 060519 Power Supply, order 114045-KIT Retrofit Kit.	1
8	F05004-255	Screw, M4-.7 x 8mm Socket Head		2
9	068319	Relay, 12A DPDT 24VDC		2

5

Replacement Parts*Auto Feed Control, DC (Optional)*

REF	PART #	DESCRIPTION	COMMENTS	QTY.
10	F05004-142	Screw, #6-32 x 3/8" Phillips Slot Round Head		2
11	F05004-18	Screw, #10-24 x 5/8" Unslotted Indented Hex Head Machine		1
12	068363	Cable Assembly, BMT250MUD Motor		1
13	068326	Sensor Assembly, BMT250DC Index		1
14	060515	Switch, On/Off Rocker		1
15	060216	Receptacle, Power Entry		1
16	F05011-37	Washer, 1/4" Exterior Star Lock		1
17	F05011-18	Washer, #10 SAE Flat		1
18	F05010-14	Nut, #10-24 Self-Locking Hex		1
19	F05015-17	Bolt, #10-24 x 1/2" Phillips Pan Head Type 23		10
	068323	Panel Assembly, BMT250DC Control		1
20	066944	Panel Weldment, BMT250DC Control		1
21	066940	Decal, BMT250DC Control		1
22	053463	Gasket, Shop Series II Setter Control		1
23	069686	Counter Assembly, Dual Setter		1
24	060509	Switch Head, Flush Push Button Green		1
25	060510	Switch Body, 1 NO Contact		1
26	060512	Switch Head, Extended Push Button Red		1
27	068322	Block, 1NC 22MM Push Green Contact		1
28	068321	Light, 24V White LED Pilot		1
29	060514	Switch, DPST Off/On Toggle		1
30	P05251-1	Washer, 1/2" ID x 3/4" OD x 1/16" Thk Nylon		1
31	024589	Boot, Toggle Switch Sealing		1
32	F05089-2	Tie Wrap, .100" x 4" Black		6
33	068320	Socket, 12A Relay Din-Mount		2
34	068328	Decal, BMT250DC US Electrical Info		1
35	069681	Decal, Electrical Hazard/Unplug Warning		1
36	069685	Decal, Rear Owner's Manual Warning		1
	016187	Decal, Revision		1
	016200	Overlayment, Revision Decal		1
37	068372	Wire Assembly, BMT250MUD Machine Ground		1

5.13 Auto Feed Control Panel, AC (Optional)

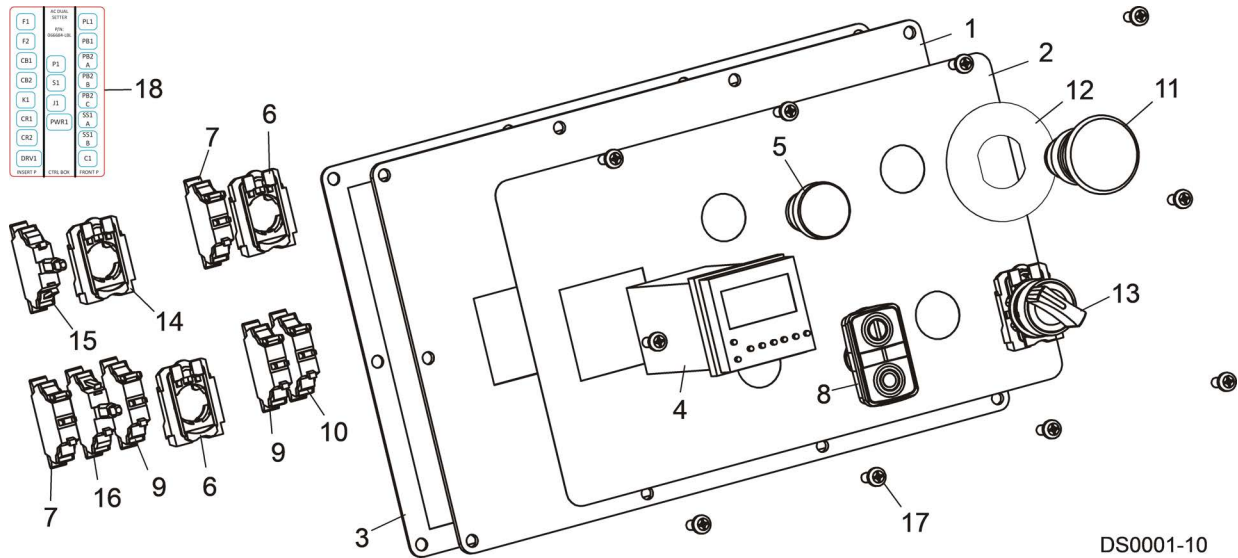

DS0001-10

REF	PART #	DESCRIPTION	COMMENTS	QTY.
	066692	PANEL ASSEMBLY, DUAL SETTER CONTROL		1
1	066682	Panel Weldment, Setter Control Front		1
2	069674	Decal, Dual Setter Front Panel		1
3	066683	Gasket, Dual Setter Front Panel		1
4	069686	Counter Assembly, Dual Setter		1
5	068932	Switch Head, White Pilot Light		1
	068950	Switch Collar Assembly, Mount		2
6	068951	Switch Collar, Mount		1
7	068921	Switch Block, Contact		1
8	068909	Push Button, Flush Marked		1
9	068920	Switch Block, NO Contact		2
10	068921	Switch Block, NC Contact		1
11	068942	E-Stop Head, Push Button		1
12	050992	Legend, Round Yellow E-Stop		1
13	066690	Switch, Maint Selector		1
14	068951	Switch Collar, Mount		1
15	068912	Light Module, White		1
16	068910	Light Module, Green		1
17	F05015-17	Bolt, #10-24 x 1/2 Phillips Pan Head		10
	066684-LBL	Decal Set, AC Dual Setter Components		1

5.14 Auto Feed Motor, AC (Optional)

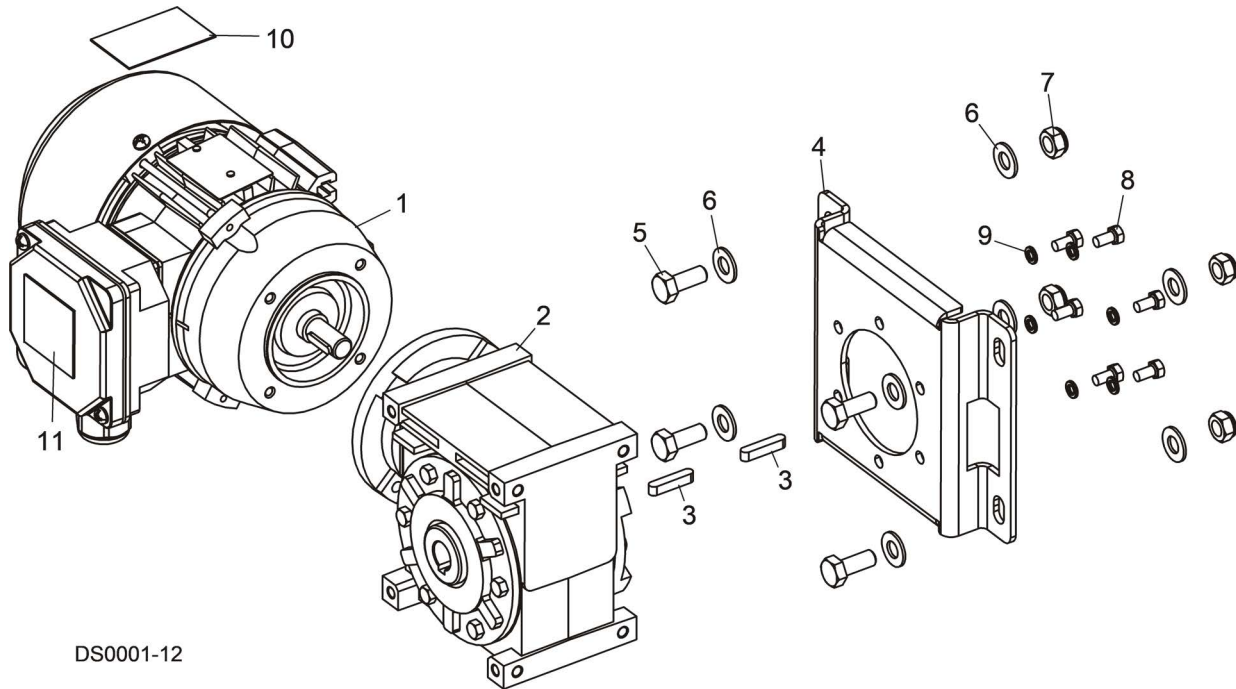

REF	PART #	DESCRIPTION	COMMENTS	QTY.
	066679	MOTOR ASSEMBLY, AC DUAL SETTER		1
	508440	Drive Assembly, 39 RPM 230V 0.12kW		1
1	508441	Motor, 1400 RPM 230/400V 1-Phase IEC		1
2	508442	Gearbox, 39 RPM IEC		1
3	066663	Key, 5 x 5 x 25mm Round End		2
4	066672	Plate, Motor Mounting		1
5	F05021-2	Bolt, M8-1.25 x 20 Hex Head Class 8		4
6	F05011-17	Washer, 5/16" SAE Flat		8
7	F05010-132	Nut, M8 Hex Nylon Lock		4
8	F05020-13	Bolt, M5-0.8 x 10 Hex Head Class 8		6
9	F05011-20	Washer, #10 Split Lock		6
10	S20097	Decal, Motor Direction		1
11	069682	Decal, Electrical Hazard Warning		1

5.15 Auto Feed Motor, DC (Optional)

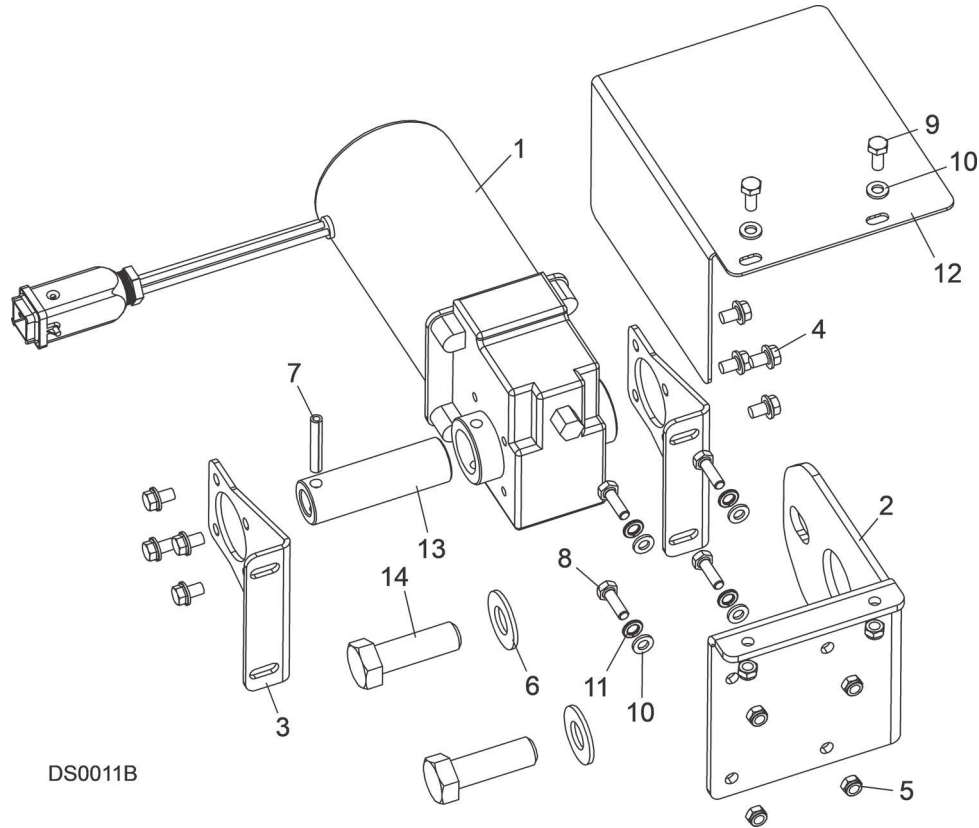

REF	PART #	DESCRIPTION	COMMENTS	QTY.
	066945	MOTOR ASSEMBLY, DC DUAL SETTER		1
1	068364	Motor Assembly, BMT250MUD		1
	060548	Motor, 24V 159-:1 1/5HP 32RPM Gear		1
2	066946	Plate, Motor Mount DC		1
3	066947	Plate, Motor DC		2
4	F05005-78	Screw, 1/4-20 x 3/8" Hex Flanged		8
5	F05010-200	Nut, M6-1.0 Nylon Lock		6
6	F05011-5	Washer, 5/8" SAE Flat		2
7	F05012-125	Pin, 1/4" x 1 1/2" Roll		1
8	F05020-6	Bolt, M6-1 x 20 Hex Head Class 8		4
9	F05020-7	Bolt, M6-1 x 14 Hex Head Class 8		2
10	F05026-1	Washer, M6 Flat Class 4		6
11	F05026-2	Washer, M6 Split Lock		4
12	066948	Plate, Top Cover DC		1
13	066955	Sleeve, 1" x 3 1/4" Motor		1
14	F81006-7	Bolt, M16 x 50 Hex Head Full Thread 8.8		2

5 Replacement Parts

Toothsetter Gauge Assembly

5.16 Toothsetter Gauge Assembly

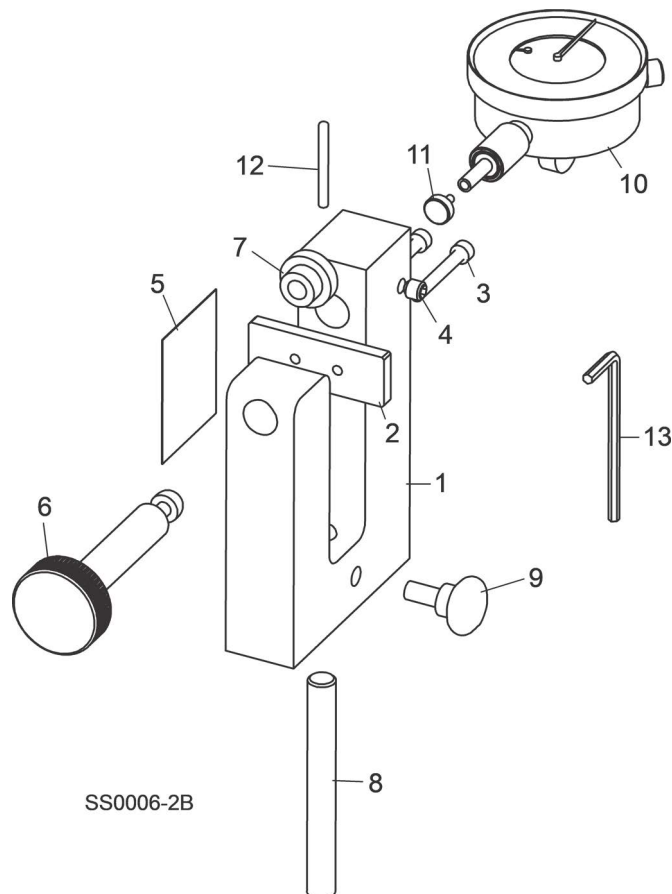

REF	PART #	DESCRIPTION	COMMENTS	QTY.
	060490	GAUGE ASSEMBLY, TOOTH SET BOXED		1
1	060495	Block, Tooth Set Gauge		1
2	060494	Plate, Tooth Set Clamp		1
3	F05004-225	Screw, #8-32 x 1 1/4" Socket Head		2
4	F05005-131	Screw, 1/4-20 x 1/4" Cup Point Socket Set		1
5	060479	Decal, Blade Reorder (Small)		1
6	060488	Knob, 1/2-13 x 2 15/16" x 1 1/4" Steel		1
7	060487	Pad, 3/4" Dia. Steel Swivel		1
8	F05012-130	Pin, 3/8" Dia. x 3 1/4" Dowel		1
9	060489	Knob, 1/4-20 x 1/2" 4-Lobe Plastic		1
10	060491	Gauge Assembly, Tooth Set		1
11	P04716-2	Foot, Tooth Set Gauge		1
12	F05012-132	Pin, 1/8" x 1 1/4" Dowel		1
13	P06187	Wrench, 1/8" Hex		1

SECTION 6 ELECTRICAL INFORMATION

6.1 Schematic, AC 120V

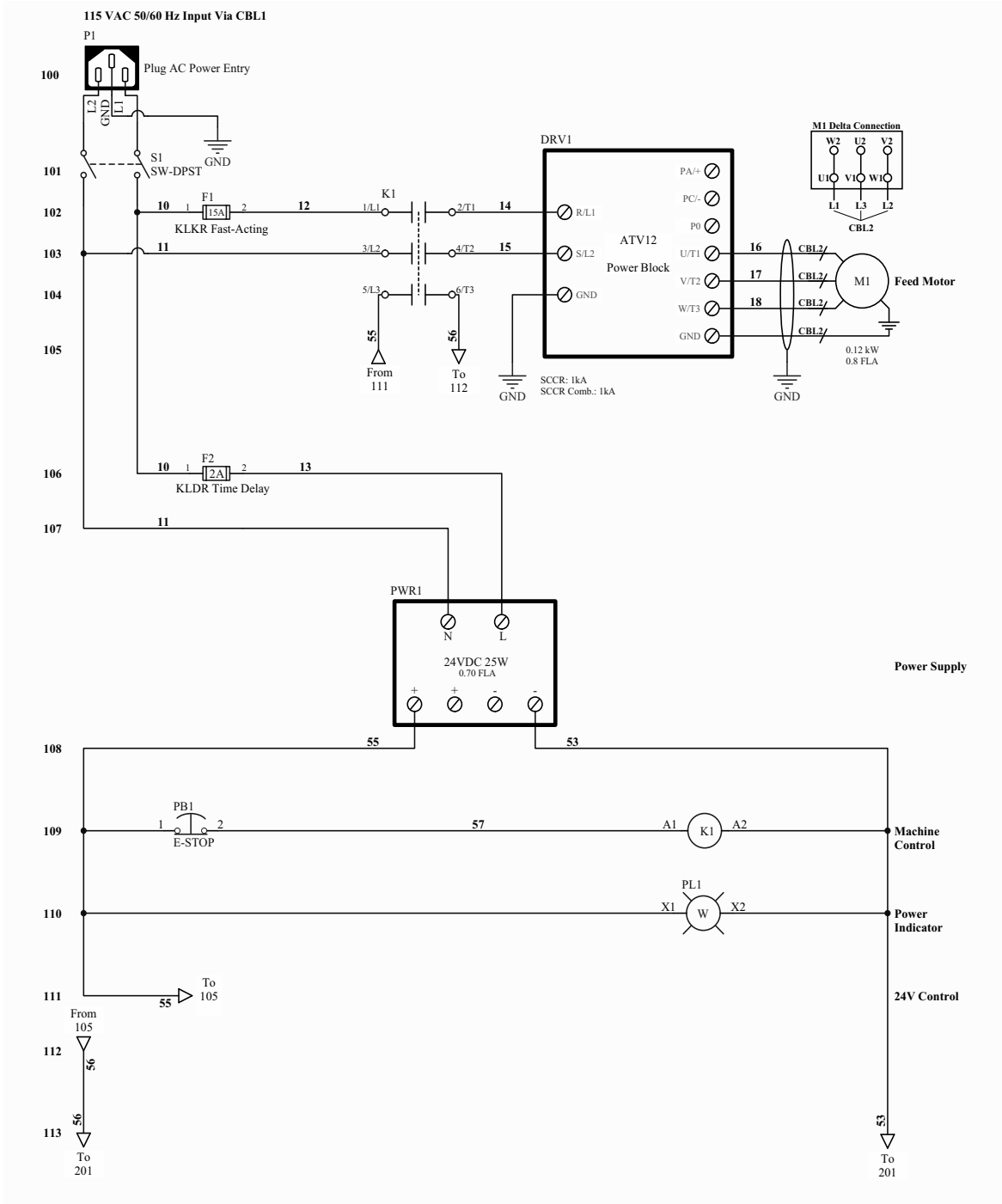

FIG. 6-1 PAGE 1 OF 2

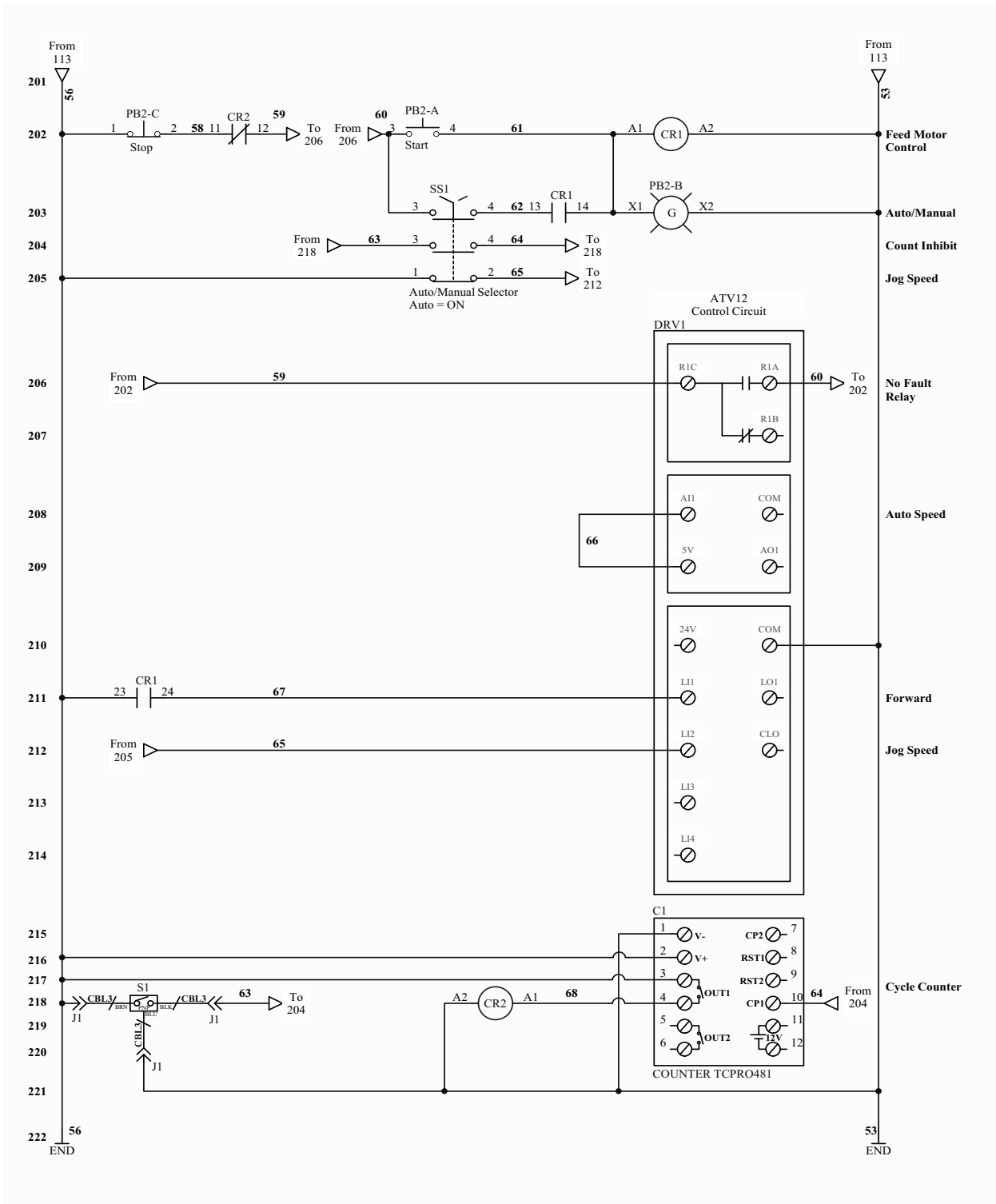

FIG. 6-2 PAGE 2 OF 2

6.2 Schematic, AC 220V

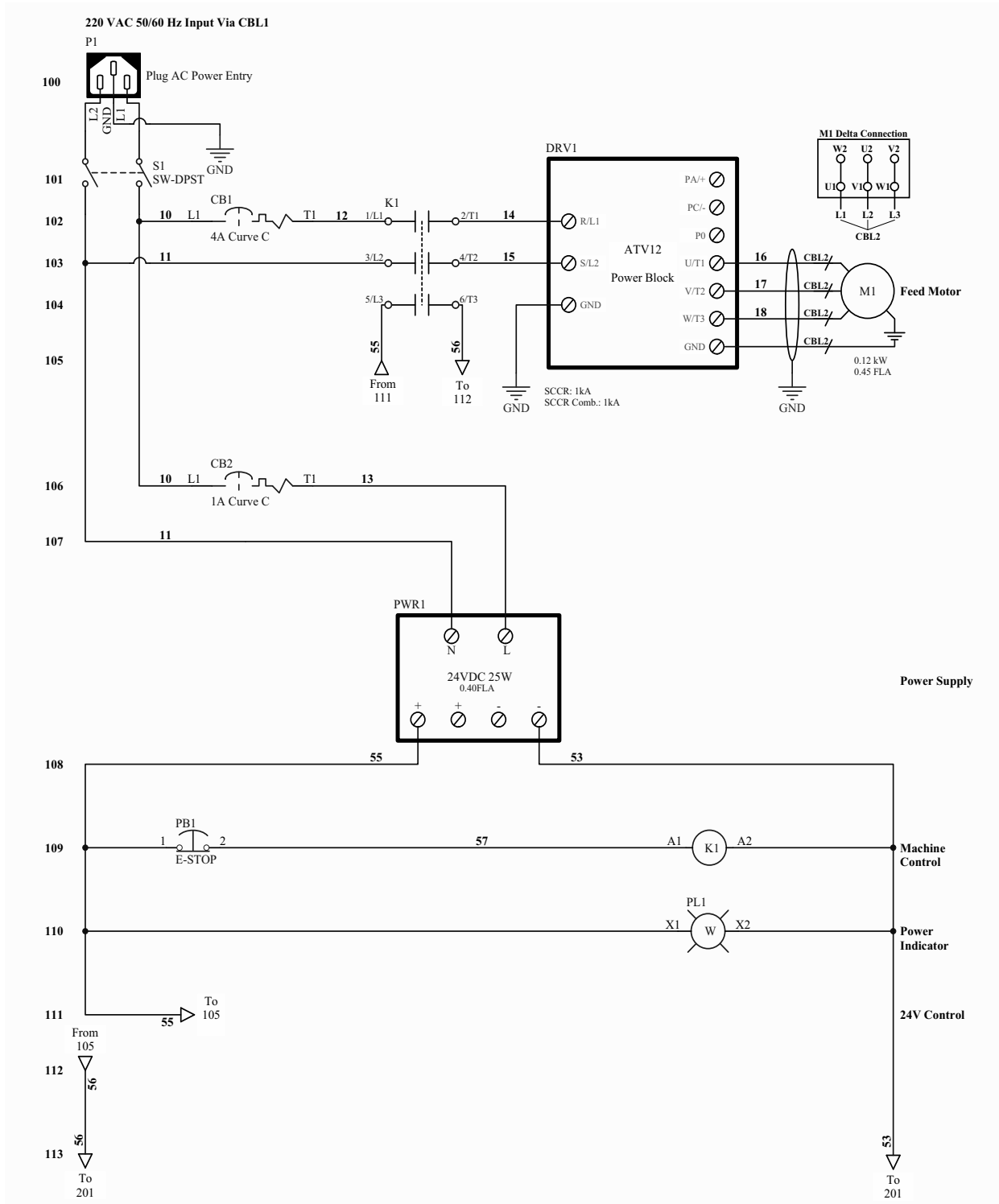

FIG. 6-3 PAGE 1 OF 2

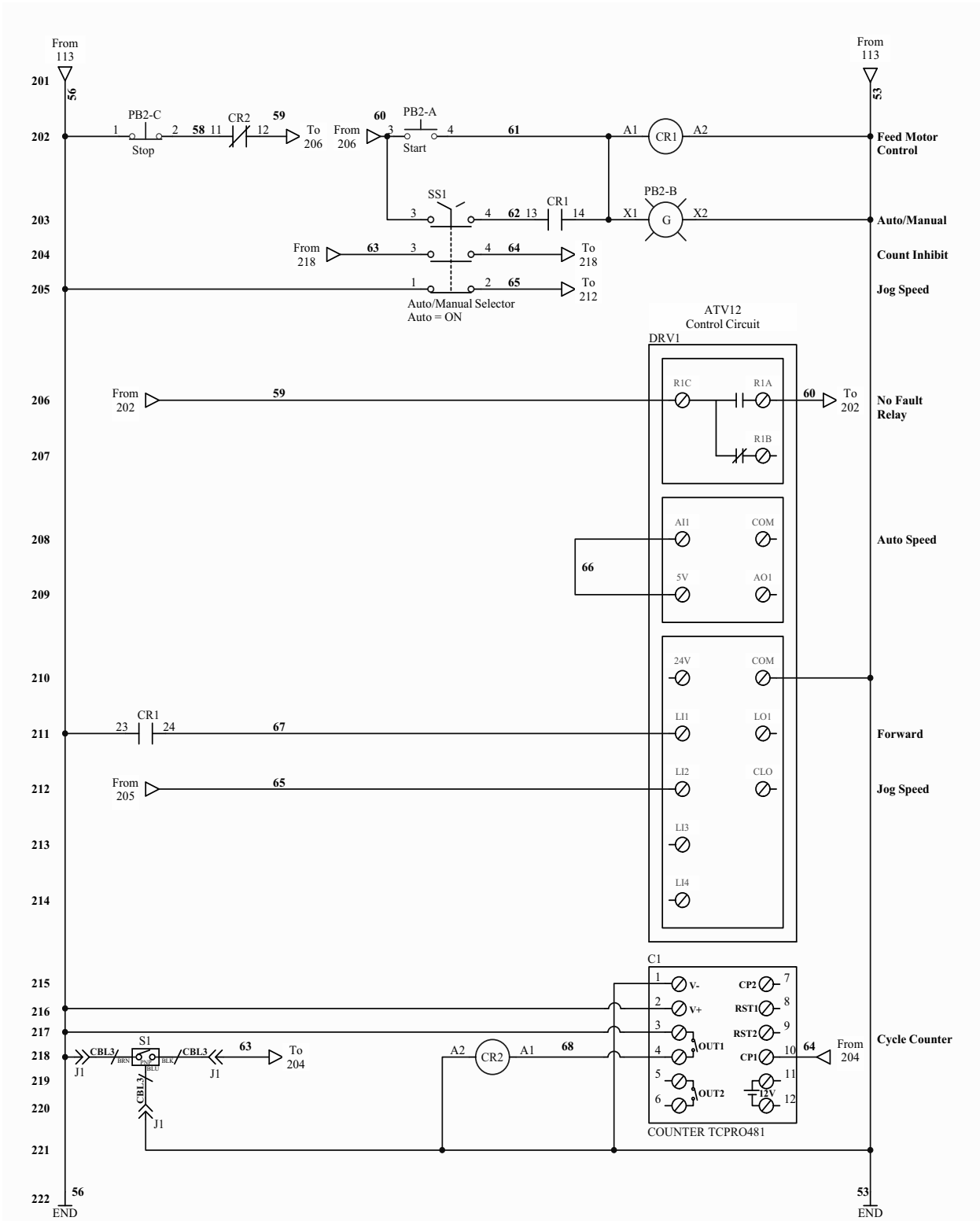

FIG. 6-4 PAGE 2 OF 2

6.3 Schematic, DC

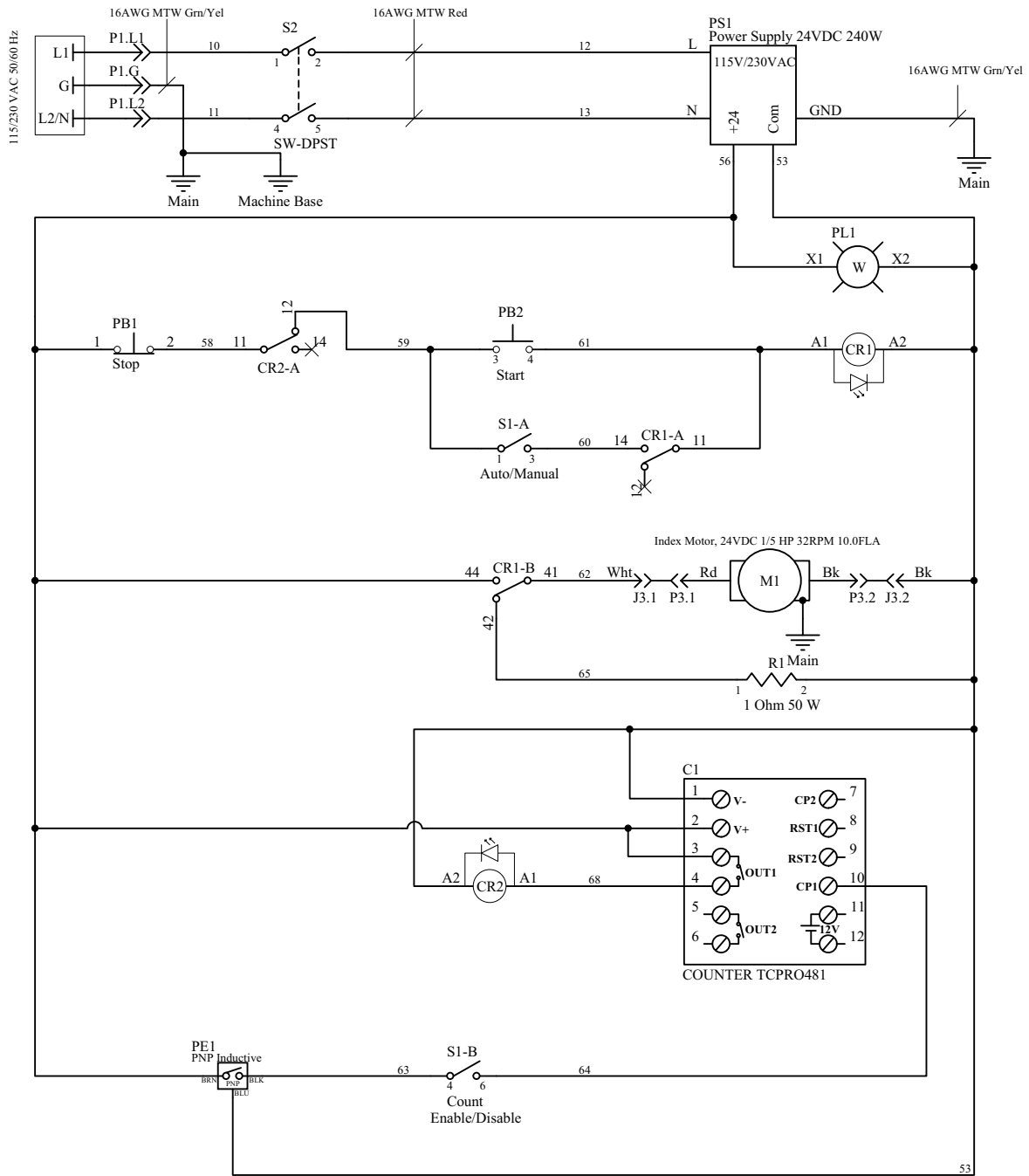
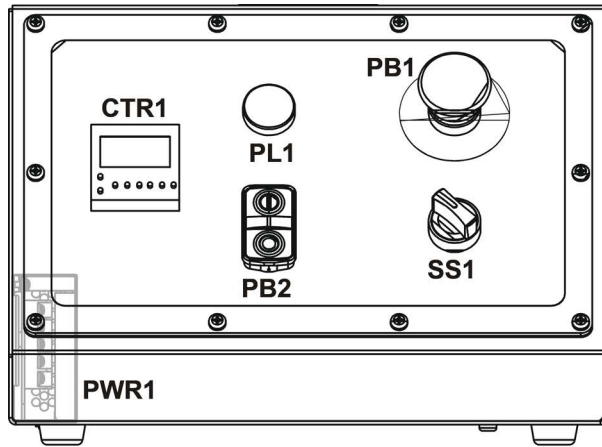

FIG. 6-5 PAGE 1 OF 1

6.4 Component Layout Diagrams (AC Only)

Front Panel, Control Box



Control Box Front

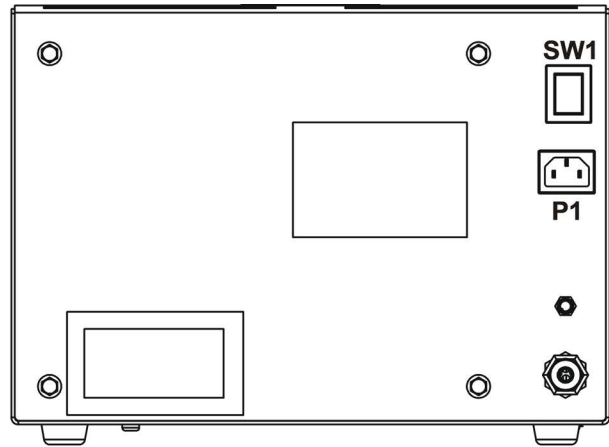

Control Box Rear

DS0004-1

FIG. 6-6

Insert Panel, Control Box

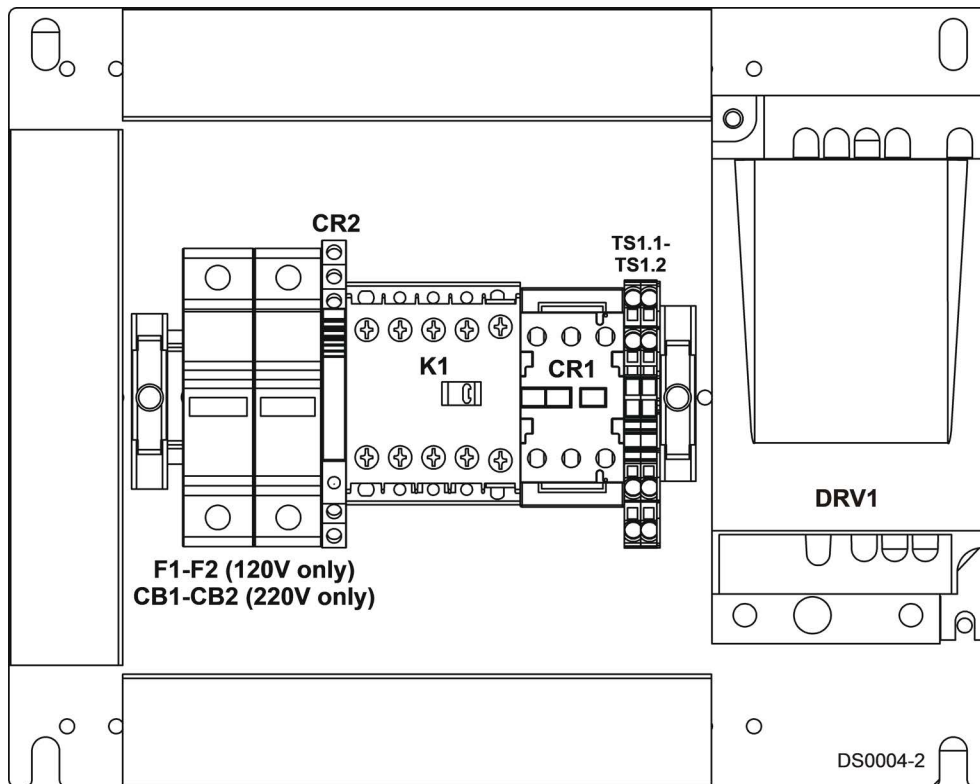

DS0004-2

FIG. 6-7

6.5 Component Layout Diagrams (DC Only)

Front Panel, Control Box

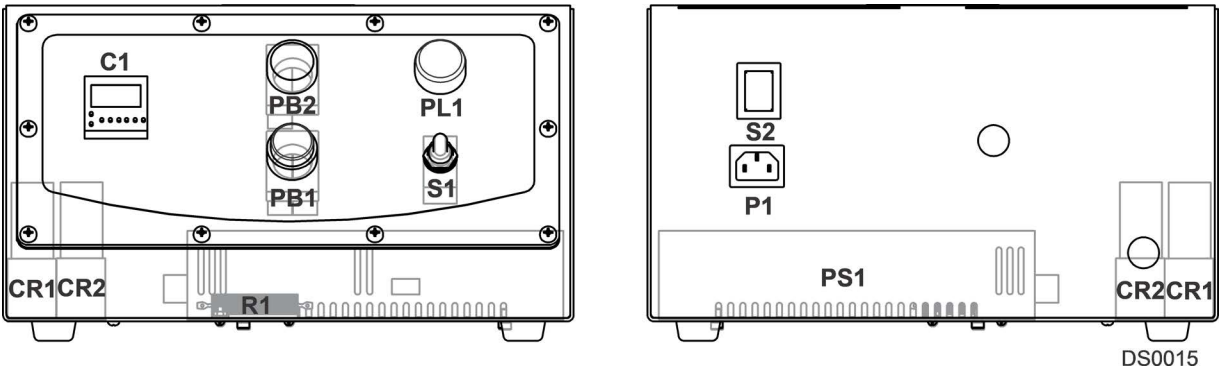

FIG. 6-8

6.6 Component List (AC Only)

ID	Wood-Mizer Part No.	Description
CB1	068313	Breaker, 4A Curve C C60N
CB2	069670	Breaker, 1P 1A Multi 9 C-Trip Curve
CR1	051684	Relay, 2NO 24VDC
CR2	052911	Relay, 1CO 6A 24VDC
CTR1	069686	Counter, Multifunction 24VDC
DRV1	069683	Drive Assembly, 120VAC AC Dual Setter
	069684	Drive Assembly, 220VAC AC Dual Setter
F1-F2	052731	Fuse Block, 1P Class CC Indicating
F1	069664	Fuse, 15A Class CC Fast Acting
F2	052446	Fuse, 2A 600V KLDR Class CC
K1	101241	Contact, 9A 3P 24VDC
M1	508440	Motor, 0.12kW 220/400V 3Ph
P1	060216	Receptacle, Power Entry
PB1	068942	Push Button Head, E-Stop P-P ZB5
	068950	Collar, 1NC ZB5 Switch Mounting
PB2	068909	Push-Button, Ill. 2 Flush Marked ZB5
	068910	Light Module, ZB5 Green
	068950	Collar, 1NC ZB5 Switch Mounting
	068920	Contact Block, NO ZB5
PL1	068932	Head, ZB5 White Pilot Light
	068912	Light Module, ZB5 White
	068951	Collar, ZB5 Switch Mounting
PWR1	068314	Power Supply, 24VDC 1.1A 25W
SW1	060515	Switch, DPST Rocker
SS1	XB5AD21	Switch, 1NO 2P Maint Selector ZB5
	ZBE1015	Contact Block, NO ZB5
	ZBE1025	Contact Block, NC ZB5
TS1	068105	End Plate
TS1.1-TS1.2	068104	Term Block, 4P Ground 2.5mm

6.7 Component List (DC Only)

ID	Wood-Mizer Part No.	Description
C1	069686	Counter, Multifunction 24VDC
CR1, CR2	068319	Relay, 12A DPDT 24VDC
M1	060500	Motor Assembly, Shop Series II Dual Setter
P1	060216	Receptacle, Power Entry
PB1	060512	Switch Head, Extended Push Button Red
	068322	Block, 1NC 22MM Push Green Contact
PB2	060509	Switch Head, Flush Push Button Green
	060510	Switch Base, 1NO Contact
PE1	068326	Sensor Assembly, BMT250DC Index
PL1	068321	Light, 24V LED White Pilot
PS1	060519	Power Supply, 110/220VAC 320W 24VDC
R1	068327	Resistor Assembly, 1 Ohm 50W
S1	060514	Switch, On/Off DPST Toggle
S2	060515	Switch, On/Off Rocker