

APPENDIX A ELECTRICAL INFORMATION

MB200EA3U SlabMizer Rev. A1.00+

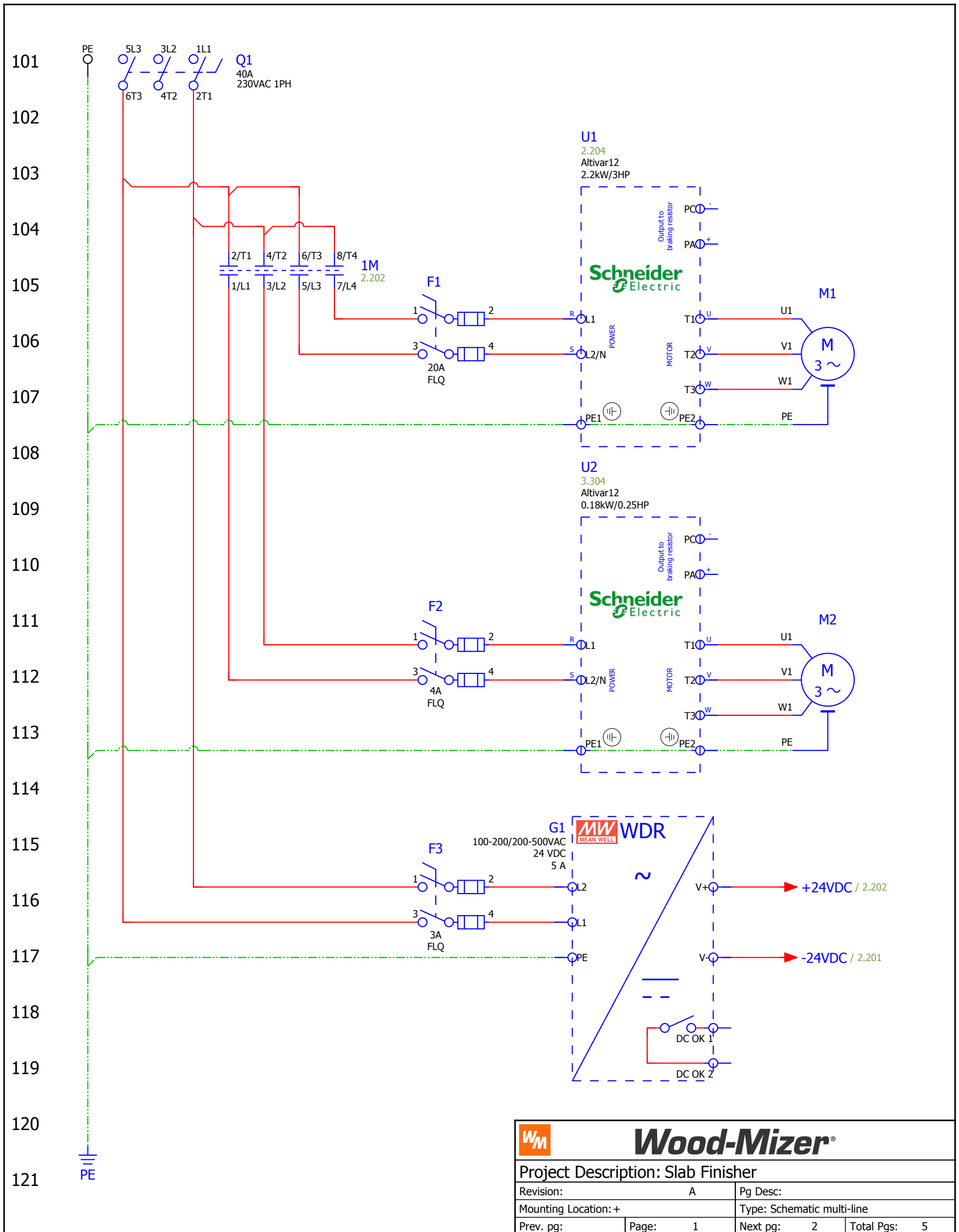

Wood-Mizer®			
Project Description: Slab Finisher			
Revision:	A	Pg Desc:	
Mounting Location:	+	Type: Schematic multi-line	
Prev. pg:	Page: 1	Next pg: 2	Total Pgs: 5

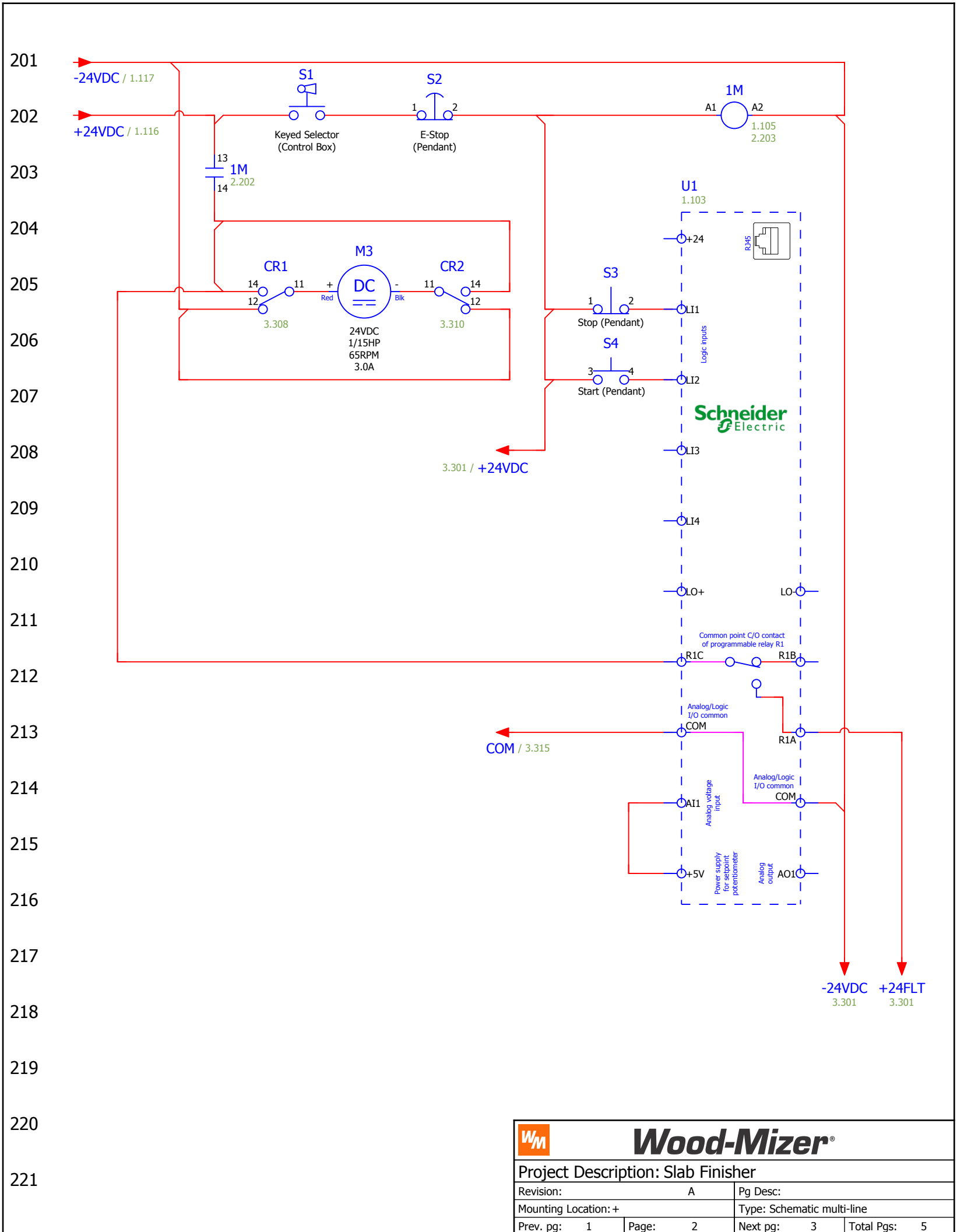

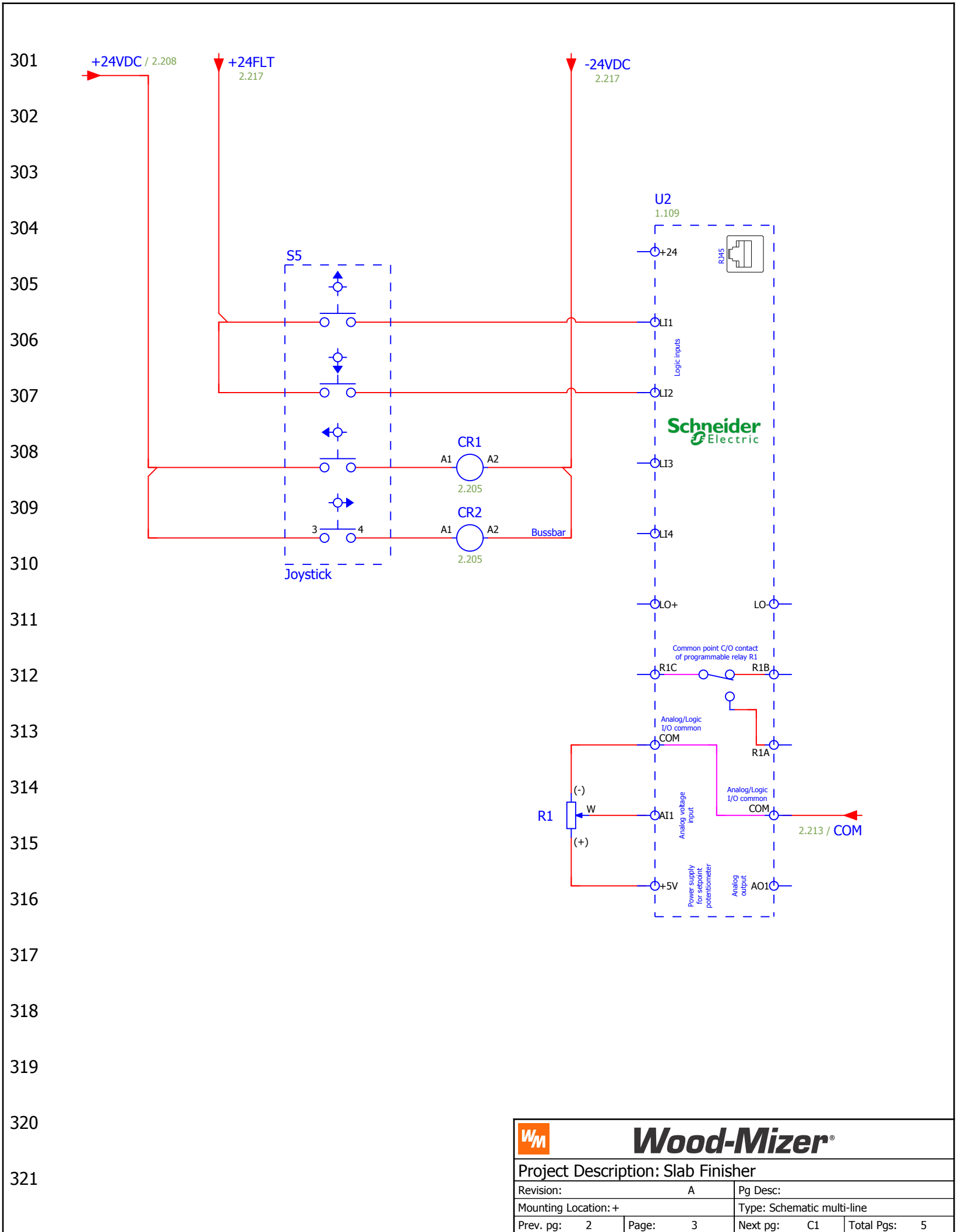

		Wood-Mizer®	
Project Description: Slab Finisher			
Revision:	A	Pg Desc:	
Mounting Location:	+	Type:	Schematic multi-line
Prev. pg:	2	Page:	3
		Next pg:	C1
		Total Pgs:	5

Device Tag/Parts List

Device tag	Function	Wood-Mizer Part Number	Wood-Mizer Description	Qty.	X-Ref
1M			Contactor, 25A 4P 24VDC Coil	1	2.202
CR1			Relay, 1CO 24VDC 16A Clmp DIN	1	3.308
CR2			Relay, 1CO 24VDC 16A Clmp DIN	1	3.310
F1			Fuse Holder, 2P 10x38mm Screw Clamp	1	1.106
F1			Fuse, 20A 500V FLQ Midget Delay	2	1.106
F2			Fuse Holder, 2P 10x38mm Screw Clamp	1	1.111
F2			Fuse, 4A 500V FLQ Midget Delay	2	1.111
F3			Fuse Holder, 2P 10x38mm Screw Clamp	1	1.116
F3			Fuse, 3A 500V FLQ Midget Delay	2	1.116
G1		068242	Power Supply, 24VDC 5A 200-500V	1	1.115
M3		035659	Motor Assy, 24V 60 RPM Gear	1	2.205
Q1		050903-1	Switch Disconnect, 40A 3Ph Non-Fused	1	1.101
Q1		050883-1	Handle, Disconnect RED/YEL 6mm Shaft	1	1.101
Q1		051673-1	Shaft, Disconnect 180mmx6mm	1	1.101
R1		076050	Potentiometer, 1K	1	3.315
S1			Keyed Selector Switch Head, 2P Maintained	1	2.202
S2		068950	Collar, Mount 1NC ZB5	1	2.202
S2		050992	Legend, E-Stop, Round Yellow	1	2.202
S2		068940	Pushbutton Head, 22mm E-Stop Twist-Pull	1	2.202
S3		068950	Collar, Mount 1NC ZB5	1	2.205
S3			Push Button Head, Flush Red	1	2.205
S4		068952	Collar, Mount 1NO ZB5	1	2.207
S4			Push Button Head, Flush Green	1	2.207
S5		068424	Joystick, 4-Position Spring Return	1	3.310
S5		068425	Contact, 1NO ABB	4	3.310
U1			AC Drive, ATV12 3HP 230V 1Ph-3Ph	1	1.103
U2		069704	AC Drive, ATV12 0.25HP 230V 1Ph-3Ph	1	1.109

	Wood-Mizer®		
Project Description: Slab Finisher			
Revision: A		Pg Desc: Parts List	
Mounting Location: +		Type: Parts list	
Prev. pg: 3	Page: C1	Next pg: C2	Total Pgs: 5

Device Tag/Parts List

WM_PARTS_LIST-Mfg

Dev. tag	Function	Manufacturer	Manufacturer Part Number	Description	Qty.	X-Ref
CR1		WAGO	788-304	Relay, 1CO 24VDC 16A Clmp DIN	1	3.308
CR2		WAGO	788-304	Relay, 1CO 24VDC 16A Clmp DIN	1	3.310
F1		Schneider Electric	DF102V	Fuse Holder, 2P 10x38mm Screw Clamp	1	1.106
F1		Littelfuse	0FLQ020.T	Fuse, 20A 500V FLQ Midget Delay	2	1.106
F2		Schneider Electric	DF102V	Fuse Holder, 2P 10x38mm Screw Clamp	1	1.111
F2		Littelfuse	0FLQ004.T	Fuse, 4A 500V FLQ Midget Delay	2	1.111
F3		Schneider Electric	DF102V	Fuse Holder, 2P 10x38mm Screw Clamp	1	1.116
F3		Littelfuse	0FLQ003.T	Fuse, 3A 500V FLQ Midget Delay	2	1.116
G1		MeanWell	WDR-120-24	Power Supply, 24VDC 5A 200-500V	1	1.115
M3		Wood-Mizer, LLC	035659	Motor Assy, 24V 60 RPM Gear	1	2.205
1M		Schneider Electric	LC1DT25BD	Contact, 25A 4P 24VDC Coil	1	2.202
Q1		ABB	OT40F3	Switch Disconnect, 40A 3Ph Non-Fused	1	1.101
Q1		ABB	OHYS2AJ	Handle, Disconnect RED/YEL 6mm Shaft	1	1.101
Q1		ABB	OXS6X180	Shaft, Disconnect 180mmx6mm	1	1.101
R1		Wood-Mizer, LLC		Potentiometer, 1K	1	3.315
S1		Schneider Electric	ZB5AG2	Keyed Selector Switch Head, 2P Maintained	1	2.202
S2		Schneider Electric	ZB5AZ1025	Collar, Mount 1NC ZB5	1	2.202
S2		Schneider Electric	ZBY9320	Legend, E-Stop, Round Yellow	1	2.202
S2		Schneider Electric	ZB5AS844	Pushbutton Head, 22mm E-Stop Twist-Pull	1	2.202
S3		Schneider Electric	ZB5AZ1025	Collar, Mount 1NC ZB5	1	2.205
S3		Schneider Electric	ZB5AA4	Push Button Head, Flush Red	1	2.205
S4		Schneider Electric	ZB5AZ1015	Collar, Mount 1NO ZB5	1	2.207
S4		Schneider Electric	ZB5AA3	Push Button Head, Flush Green	1	2.207
S5		ABB	MJS6-60B	Joystick, 4-Position Spring Return	1	3.310
S5		ABB	MCB-10	Contact, 1NO ABB	4	3.310
U1		Schneider Electric	ATV12HU22M2	AC Drive, ATV12 3HP 230V 1Ph-3Ph	1	1.103
U2		Schneider Electric	ATV12H018M2	AC Drive, ATV12 0.25HP 230V 1Ph-3Ph	1	1.109

Wood-Mizer®

Project Description: Slab Finisher

Revision: A	Pg Desc: Parts list : WAGO.788-304 - SE.ATV12H018M2
Mounting Location: +	Type: Parts list
Prev. pg: C1	Page: C2
Next pg:	Total Pgs: 5

Cable Overview

Cable Designation	Cable Part Number	Cable Description	Cable X-Ref
	127071	Harness, Pendant 25ft	
	068456	Prox Cable	