

Wood-Mizer® Slabmizer

Parts Manual

MB200

rev. A1.00

Safety is our #1 concern!

Form #2409

MODELS AFFECTED:

MB200EA3U
MB200EA3UAF
MB200EA3UW
MB200EA3UWAF



WARNING! Read and understand this manual before using this machine.

California
Proposition 65 Warning



WARNING: Breathing gas/diesel engine exhaust exposes you to chemicals known to the State of California to cause cancer and birth defects or other reproductive harm.

Always start and operate the engine in a well-ventilated area.
If in an enclosed area, vent the exhaust to the outside.
Do not modify or tamper with the exhaust system.
Do not idle the engine except as necessary.

For more information go to **www.P65warnings.ca.gov**.



WARNING: Drilling, sawing, sanding or machining wood products can expose you to wood dust, a substance known to the State of California to cause cancer. Avoid inhaling wood dust or use a dust mask or other safeguards for personal protection.

For more information go to **www.P65Warnings.ca.gov/wood**.

Active Patents assigned to Wood-Mizer, LLC

Wood-Mizer, LLC has received patents that protect our inventions which are a result of a dedication to research, innovation, development, and design. Learn more at: woodmizer.com/patents

©2024 Wood-Mizer LLC

Printed in the United States of America, all rights reserved. No part of this manual may be reproduced in any form by any photographic, electronic, mechanical or other means or used in any information storage and retrieval system without written permission from

Wood-Mizer, LLC
8180 West 10th Street
Indianapolis, Indiana 46214

SECTION 1 REPLACEMENT PARTS

1.1 How To Use The Parts List..... 1-1
 To Order Parts 1-1
1.2 Sample Assembly..... 1-1
1.3 Torque Values..... 1-2

SECTION 2 BED ASSEMBLY

2.1 Bed Assembly 2-1
2.2 Leg Assembly 2-2
2.3 Bed Extension (Optional)..... 2-1
2.4 Clamp Assembly 2-2
2.5 Clamps (Hold Down Side Mount) 2-3

SECTION 3 GANTRY ASSEMBLY

3.1 Cross Feed..... 3-1
3.2 Power Feed Right..... 3-2
3.3 Power Feed Left..... 3-4

SECTION 4 UP / DOWN ASSEMBLY

4.1 Bearings 4-1
4.2 Up Down 4-2
4.3 Handle Up/Down 4-4
4.4 Handle, Push 4-5

SECTION 5 MOTOR ASSEMBLY

5.1 Motor Assembly 5-1

SECTION 6 ELECTRICAL BOX

6.1 Pendant..... 6-1
6.2 Stand..... 6-2
6.3 Enclosure..... 6-3

SECTION 1 REPLACEMENT PARTS

1.1 How To Use The Parts List

- Use the table of contents to locate the assembly that contains the part you need.
- Go to the appropriate section and locate the part in the illustration.
- Use the number pointing to the part to locate the correct part number and description in the table.
- Parts shown indented under another part are included with that part.

To Order Parts

- From the continental US, call **1-800-525-8100** to order parts. Have your customer number, vehicle identification number, and part numbers ready when you call.
- From other international locations, contact the Wood-Mizer distributor in your area for parts.

1.2 Sample Assembly



REF	PART #	DESCRIPTION	COMMENTS	QTY.
	012345	SAMPLE ASSEMBLY, COMPLETE	INCLUDES ITEMS 1-6	1
1	F02222-22	Sample Part		1
2	F03333-33	Sample Part		2
	098765	Sample Subassembly	Includes items 3-6	1
3	S04444-44	Subassembly Sample Part		1
4	K55555	Subassembly Sample Part		1
	054321	Sample Sub-Subassembly	Includes items 5-6	2
5	022222	Sub-Subassembly Sample Part		1
6	F10234-56	Sub-Subassembly Sample Part		1

The Sample Assembly, Complete, part number 02345 (top level assembly) includes two parts (F0222-22 and F0333-33) and the 098765 subassembly.

Subassembly 098765 contains two parts(S04444-44 and K55555) and two copies of sub-subassembly 054321.

Each sub-subassembly 054321 contains two parts (022222 and F10234-56).

1.3 Torque Values

Grade		Units	SAE 5	SAE 8
Grade Mark				
Bolt Dia.	Threads. Per In.	Units	SAE 5	SAE 8
6	32	in-lbs (Nm)	20 (2.3)	-
8	32	in-lbs (Nm)	24 (2.7)	30 (3.4)
10	24	in-lbs (Nm)	35 (4.0)	45 (5.1)
10	32	in-lbs (Nm)	40 (4.5)	50 (5.7)
12	24	in-lbs (Nm)	50 (5.7)	65 (7.3)
1/4	20	in-lbs (Nm)	95 (10.7)	125 (14.1)
1/4	28	in-lbs (Nm)	95 (10.7)	150 (17.0)
5/16	18	ft-lbs (Nm)	17 (22.6)	23 (31.2)
5/16	24	ft-lbs (Nm)	20 (27.1)	25 (33.8)
3/8	16	ft-lbs (Nm)	30 (40.7)	40 (54.2)
3/8	24	ft-lbs (Nm)	35 (47.5)	45 (61.0)
7/16	14	ft-lbs (Nm)	50 (67.8)	65 (88.1)
7/16	20	ft-lbs (Nm)	55 (74.6)	70 (94.9)
1/2	13	ft-lbs (Nm)	75 (101.7)	100 (135.6)
1/2	20	ft-lbs (Nm)	85 (115.3)	110 (149.2)
9/16	12	ft-lbs (Nm)	105 (142.4)	135 (183.1)
9/16	18	ft-lbs (Nm)	115 (155.9)	150 (203.4)
5/8	11	ft-lbs (Nm)	150 (203.4)	195 (264.4)
5/8	18	ft-lbs (Nm)	160 (217.0)	210 (284.8)
3/4	10	ft-lbs (Nm)	170 (230.5)	220 (298.3)
3/4	16	ft-lbs (Nm)	175 (237.3)	225 (305.1)
7/8	9	ft-lbs (Nm)	302 (409.5)	473 (640.9)
7/8	14	ft-lbs (Nm)	300 (406.8)	400 (542.4)
1	8	ft-lbs (Nm)	466 (631.8)	714 (967.4)

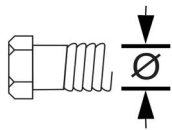

Metric Bolt Head Identification



Metric Grade 8.8



Metric Grade 10.9

COARSE THREAD					FINE THREAD				Wrench Size	
Diameter & Thread Pitch	Metric 8.8		Metric 10.9		Diameter & Thread Pitch	Metric 8.8		Metric 10.9		
	N-m	lbs-ft	N-m	lbs-ft		N-m	lbs-ft	N-m		lbs-ft
6 x 1.0	8	6	11	8					10 mm	
8 x 1.25	20	15	27	20	8 x 1.0	21	16	29	22	13 mm
10 x 1.5	39	29	54	40	10 x 1.25	41	30	57	42	16 mm
12 x 1.75	68	50	94	70	12 x 1.25	75	55	103	76	18 mm
14 x 2.0	109	80	151	111	14 x 1.5	118	87	163	120	21 mm
16 x 2.0	169	125	234	173	16 x 1.5	181	133	250	184	24 mm
18 x 2.5	234	172	323	239	18 x 1.5	263	194	363	268	27 mm
20 x 2.5	330	244	457	337	20 x 1.5	367	270	507	374	30 mm
22 x 2.5	451	332	623	460	22 x 1.5	495	365	684	505	34 mm
24 x 3.0	571	421	790	583	24 x 2.0	623	459	861	635	36 mm
30 x 3.0	1175	867	1626	1199	30 x 2.0	1258	928	1740	1283	46 mm

SECTION 2 BED ASSEMBLY

2.1 Bed Assembly

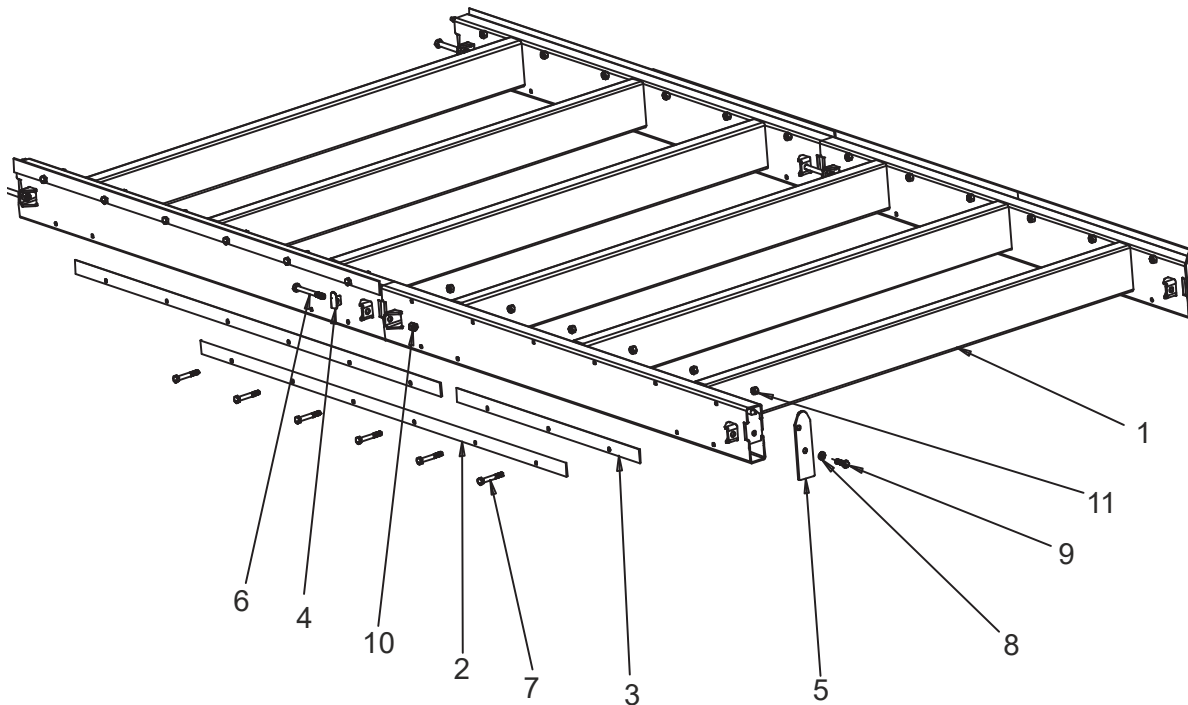

REF	PART #	DESCRIPTION	COMMENTS	QTY.
	127010	ASSY, MB200 SURFACE PLANER BED		1
	127217	ASSY, MB200 WIDESURFACE PLANER BED		1
1	127150	Weldment, Bed		3
	127218	Weldment, Wide Bed		3
2	127167	Rail, Long		10
3	127169	Rail, Short		4
4	127155	Clip Chain Retainer		4
5	127168	Plate, End Stop		4
6	F05023-10	Bolt, M12-1.75x110 HH		8
7	F05022-15	Bolt, M10-1.5x70 HH		36
8	F05011-134	Washer, M10		4
9	F05004-97	Screw, M10x1.5x35mm HH Zinc		4
10	F05010-209	Nut, M12x1.75 Hex Nylock Zinc		8
11	F05004-270	Nut, M10x1.5 Hex Nylock		36

2.2 Leg Assembly

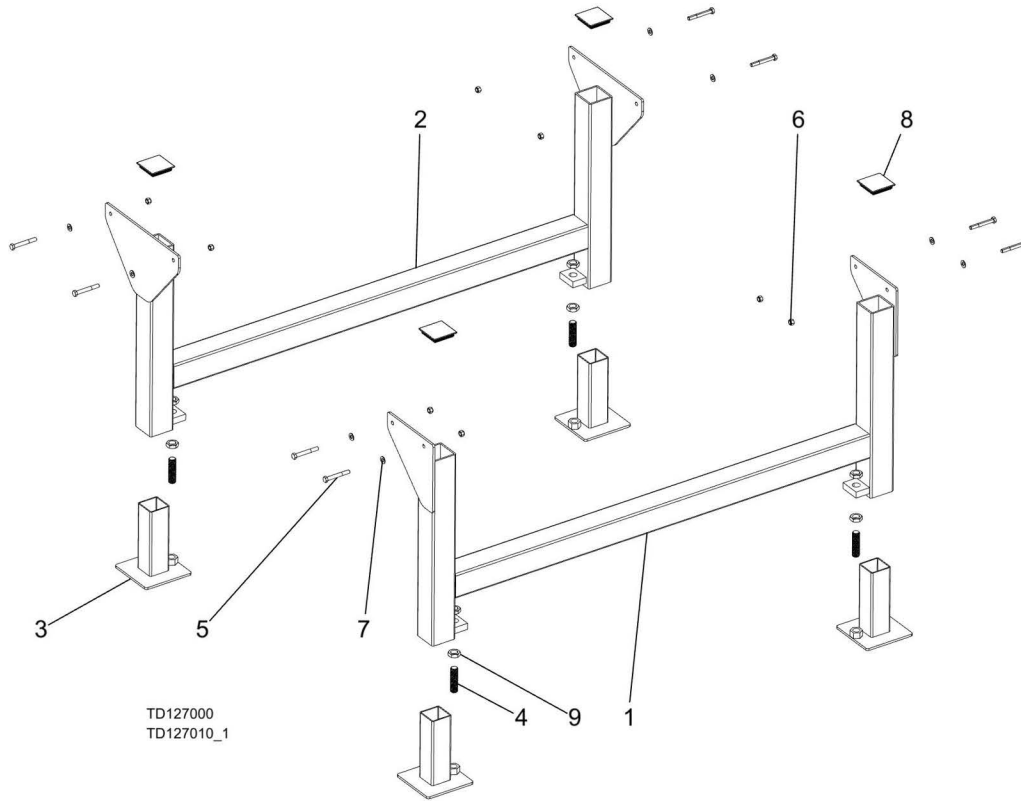

REF	PART #	DESCRIPTION	COMMENTS	QTY.
1	127053	Weldment, Leg End		2
2	127054	Weldment, Leg Center		2
3	127172	Weldment, Foot		8
4	127171	Stud, m20-2.5 free		8
5	F05022-15	Bolt, M10-1.5x75 HH Class 8.8		52
6	F05004-270	Nut, M10-1.50 Hex Nyl Lock		53
7	F05011-134	Washer, M10 Flat		20
8	127170	Cap, Tube		8

2.3 Bed Extension (Optional)

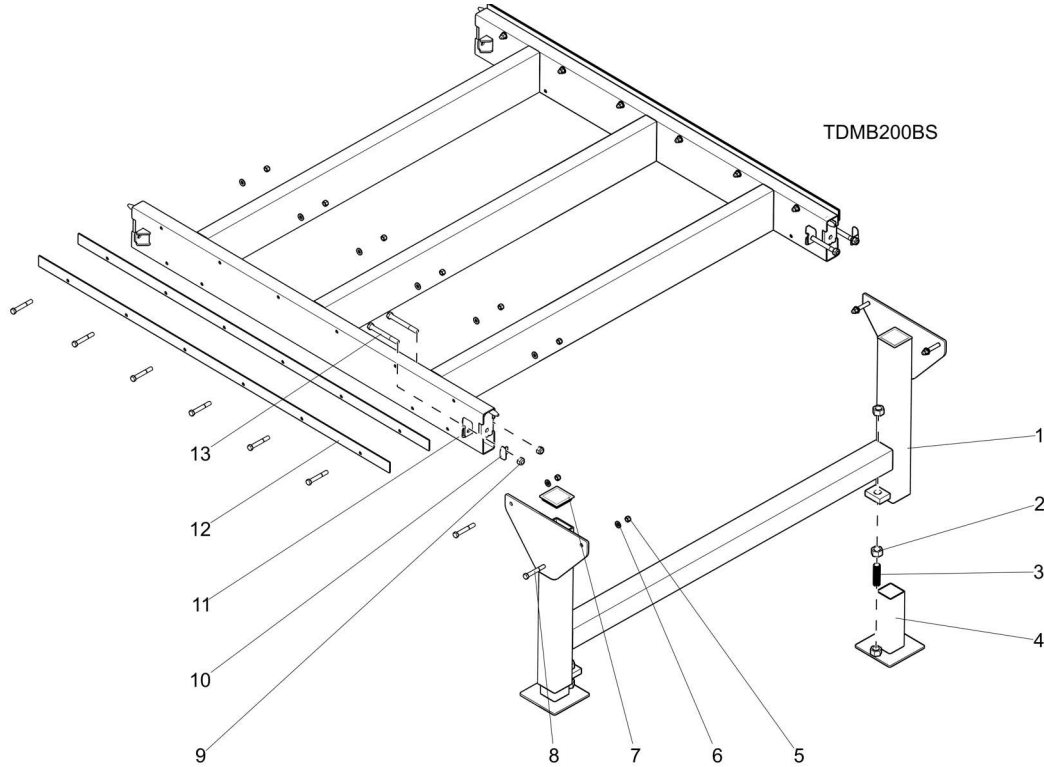

REF	PART #	DESCRIPTION	COMMENTS	QTY.
	MB200BS	MB200 Bed Extension 5'		1
	MB200BSW	MB200 Wide Bed Extension 5'		1
1	127054	Weldment, Leg Center		1
	127222	Weldment, Leg Center Wide		1
2	F05027-26	Nut, M20-2.5 Free		4
3	127171	Stud, M20-2.5 Free		2
4	127172	Wldmnt, Foot		1
5	F05004-270	Nut, M10-1.50 Hex Nyl Lock		16
6	F05011-134	Washer, M10 Flat		16
7	127170	Cap, Tube		2
8	F05022-15	Bolt, M10-1.5x75 HH Class 8.8		16
9	F05010-209	Nut, M12x1.75 Hex Nylock		4
10	127155	Clip Chain Retainer		2
11	127050	Wldmnt, Bed		1
	127218	Wldmnt, Bed Wide		1
12	127167	Rail, Long		4
13	F05023-10	Bolt, M12-1.75 x 115 HH Class 8.8		4
	127266	Chain, #40 Feed-Ext 60" or 120 links		1
	128117	Decal, Kit SlabMizer		1
	128176	Decal, Kit SlabMizer Wide		1

2.4 Clamp Assembly

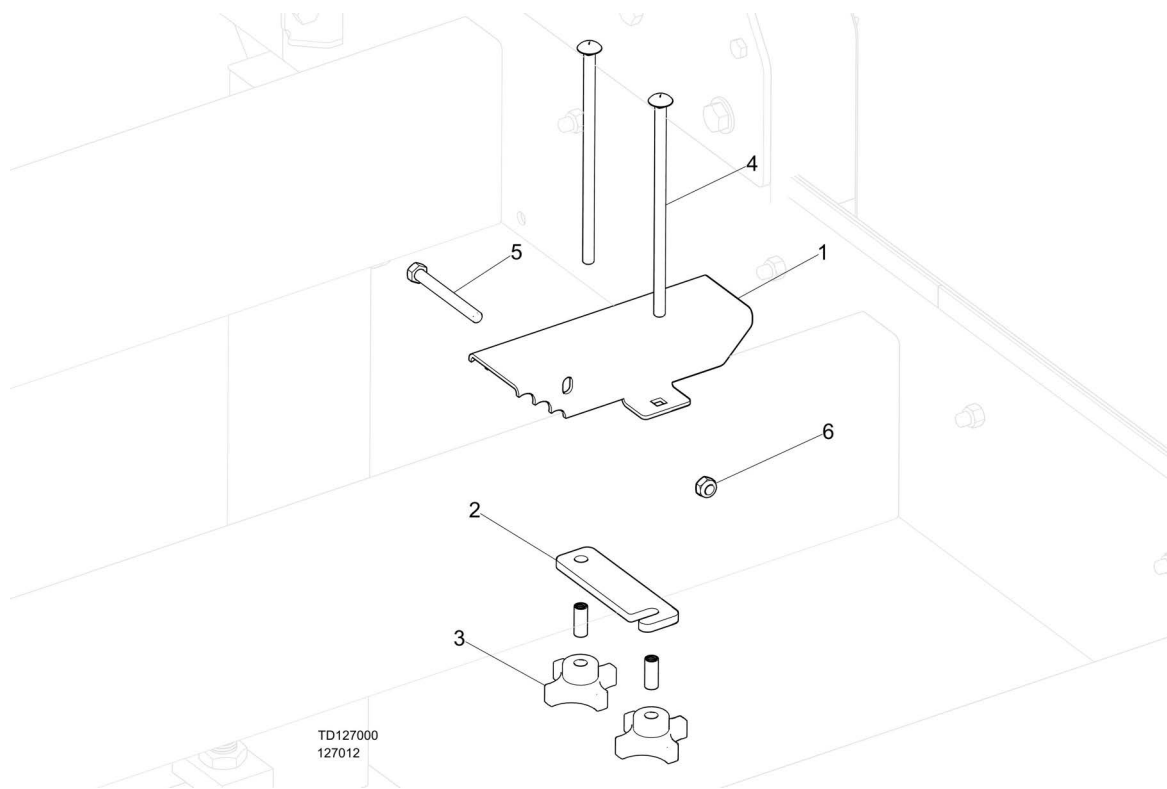

REF	PART #	DESCRIPTION	COMMENTS	QTY.
	127012	Clamp assembly		1
1	127173	Plate, clamp		1
2	127174	Strap, clamp		1
3	127176	Nut, 5/16-16 Knob		2
4	F05006-112	Bolt, 5/16-18x7 Carriage FT		2
5	F05021-19	Bolt, M8-1.25x75mm HH FT CI 8.8		1
6	F05010-132	Nut, M8-1.25 Hex Nylock		1

2.5 Clamps (Hold Down Side Mount)

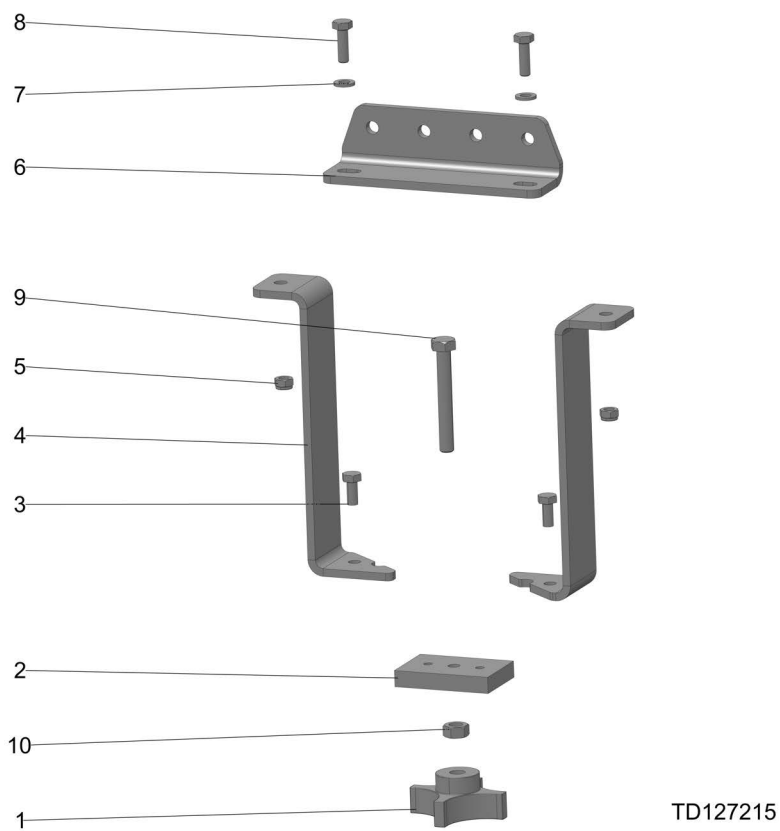

REF	PART #	DESCRIPTION	COMMENTS	QTY.
	127215	Assembly, Hold Down Side Mount		4
1	127263	Knob, Clamp Adjustment		1
2	127213	Block, Bottom Clamp		1
3	F05020-7	Bolt, M6-1 x 14 Class 8 HH		2
4	127214	Plate, Side Clamp		2
5	F05010-200	Nut, M6-1.0 Nylon Lock		2
6	127216	Angle, Top Clamp		1
7	F05026-1	Washer, M6 Flat Class 4		2
8	F05020-6	Bolt, M6-1x20 HH Class 8		2
9	F05021-15	Bolt, M8-1.25x60 HH Class 8.8		1
10	F05010-162	Nut, M8-1.25 Free Zinc Plate		1

SECTION 3 GANTRY ASSEMBLY

3.1 Cross Feed

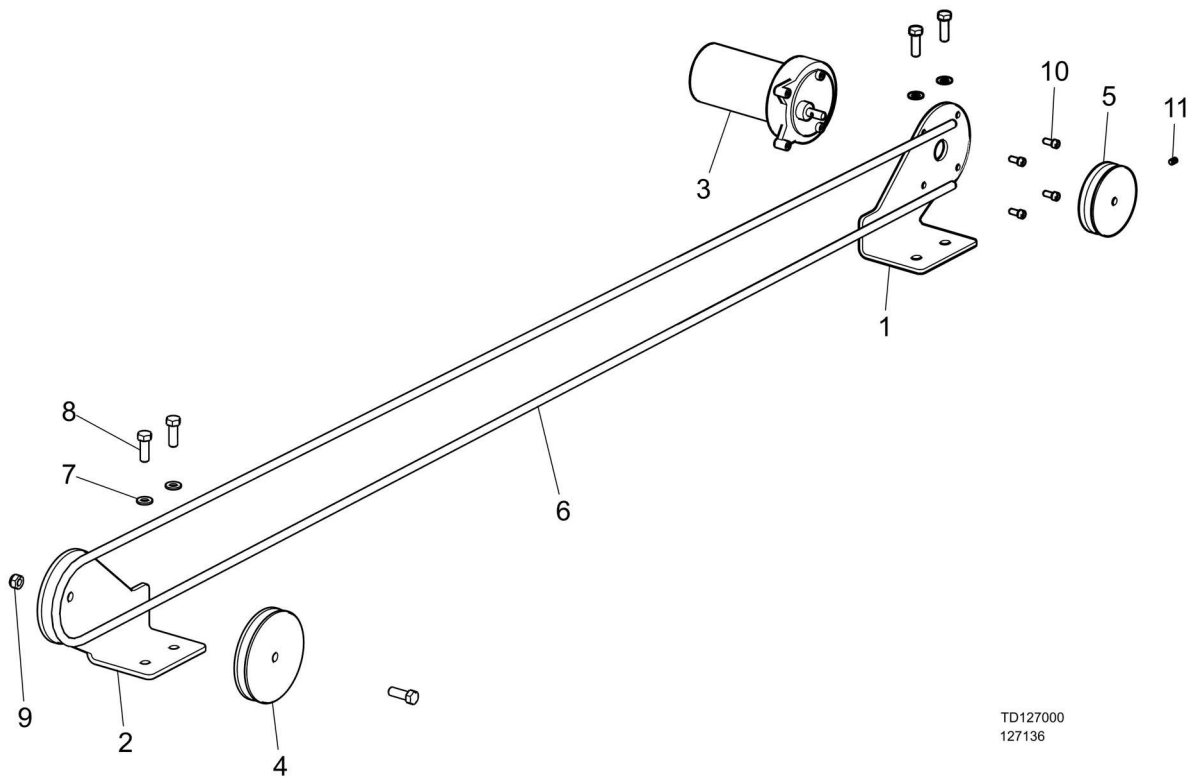

TD127000
127136

REF	PART #	DESCRIPTION	COMMENTS	QTY.
	127136	Cross Feed		1
1	127125	Plate, Cross Motor Mount		1
2	127126	Plate, Cross Idler Mount		1
3	060105	Motor, 1/15HP 31 RPM 24VDC 97:1 Gear		1
4	127127	Pulley, Idler		1
5	127135	Pulley, Rope Drive		1
6	127137	Rope, Cross Feed		1
7	F05026-4	Washer, M8 Flat		4
8	F05004-40	Bolt, M8x1.25x25 HH FT		5
9	F05010-132	Nut, M8-1.25 Hex Nylock		1
10	F05004-79	10-32 X 1/2 SHCS B/O		4
11	F05020-93	Screw, M5-0.8x10mm Cone-point Set Screw		1

3.2 Power Feed Right

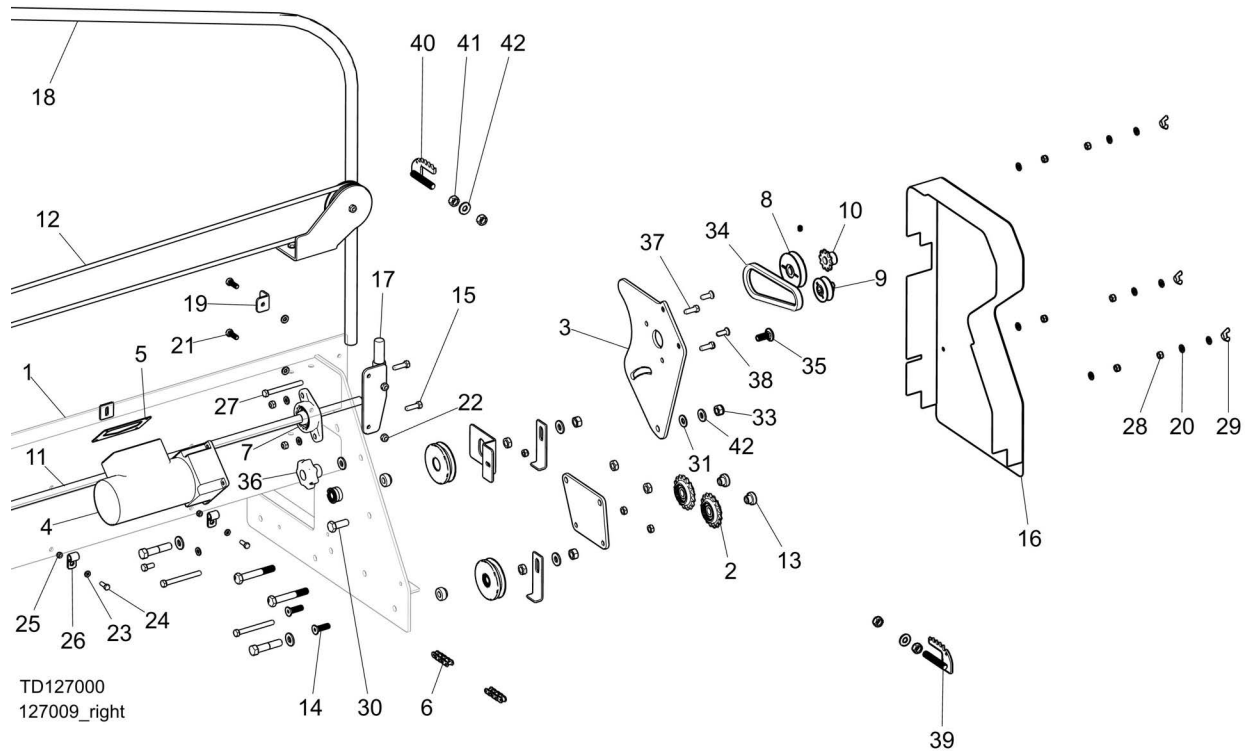

REF	PART #	DESCRIPTION	COMMENTS	QTY.
1	127056	Gantry		1
2	016366	Sprocket, Assembly		4
3	127182	Plate, Feed Motor Mount		1
4	025702	Motor, 1/6HP 90RPM 230V 3PH 19:1 Gear		1
5	073702-1	Gasket, HR130 Motor Plate		1
6	127183	Chain, #40 Feed- 216 1/2" or 433 links		2
7	127112	Bearing, 5/8" Bore 2 Bolt Flange		2
8	127101	Pulley, V-Belt 3" A		1
9	127102	Pulley, V-Belt 2" A		1
10	P04027	Sprocket, 41B10x5/8		2
11	127104	Shaft, 5/8x 63 3/4		1
12	127136	Cross Feed	(See Section 3.1)	1
13	127148	Bushing, Idler Sprocket Spacer		4
14	F05022-59	Bolt, M10-1.50x35mm BO FHS Class 10.9		4
15	F05021-18	Bolt, M8-1.25x30 FT HH Class 8.8		2
16	127154	Cover, Chain Drive		1
17	127161	Mount, Vacuum Hose Arm		1
18	127163	Tube, Vacuum Hose Arm		1
19	127164	Plate, Head Stop		2
20	F05026-4	Washer, M8 Flat		30
21	F05021-20	Bolt, M8-1.25 x 25 HH 8.8		4
22	F05010-132	Nut, M8-1.25 Hex Nylock		16
23	F05026-1	Washer, M6 Flat Class 4		6

REF	PART #	DESCRIPTION	COMMENTS	QTY.
24	F05020-6	Bolt, M6-1x20 HH Class 8		6
25	F05010-200	Nut, M6-1.0 Nylon Lock		2
26	P07584	Clamp, 1/2EMT Coated		2
27	F05004-247	Bolt, M8x1.25x90mm HH FT CL8.8 Zinc		6
28	F05010-162	Nut, M8-1.25 Free Zinc		6
29	F05027-30	Nut, M8-1.25 Wing		6
30	F05004-278	Bolt, M12x1.25x35mm HH Znc		1
31	127178	Washer, Spring Belleville		1
32	F05011-124	WASHER, M12 FLAT Zinc		2
33	F05010-209	Nut, M12x1.75 Hex Nylock		1
34	127177	Belt, A23		1
35	F05023-33	Bolt, M12-1.75x30 Class 8.8 FT Carriage Zinc		1
36	127179	Knob, M12		1
37	F05004-40	Bolt, M8x1.25x25 HH FT		2
38	F05021-30	Screw, M8x1.25x25mm Flat Socket C/S BO		2
39	127145	Weldment, Chain tensioner #1 Slabmizer		1
40	127144	Weldment, Chain tensioner #2 Slabmizer		1
41	F05010-212	Nut, M12x1.75 Free Znc		4
42	F05011-124	Washer, M12 Flat Zinc		4

3.3 Power Feed Left

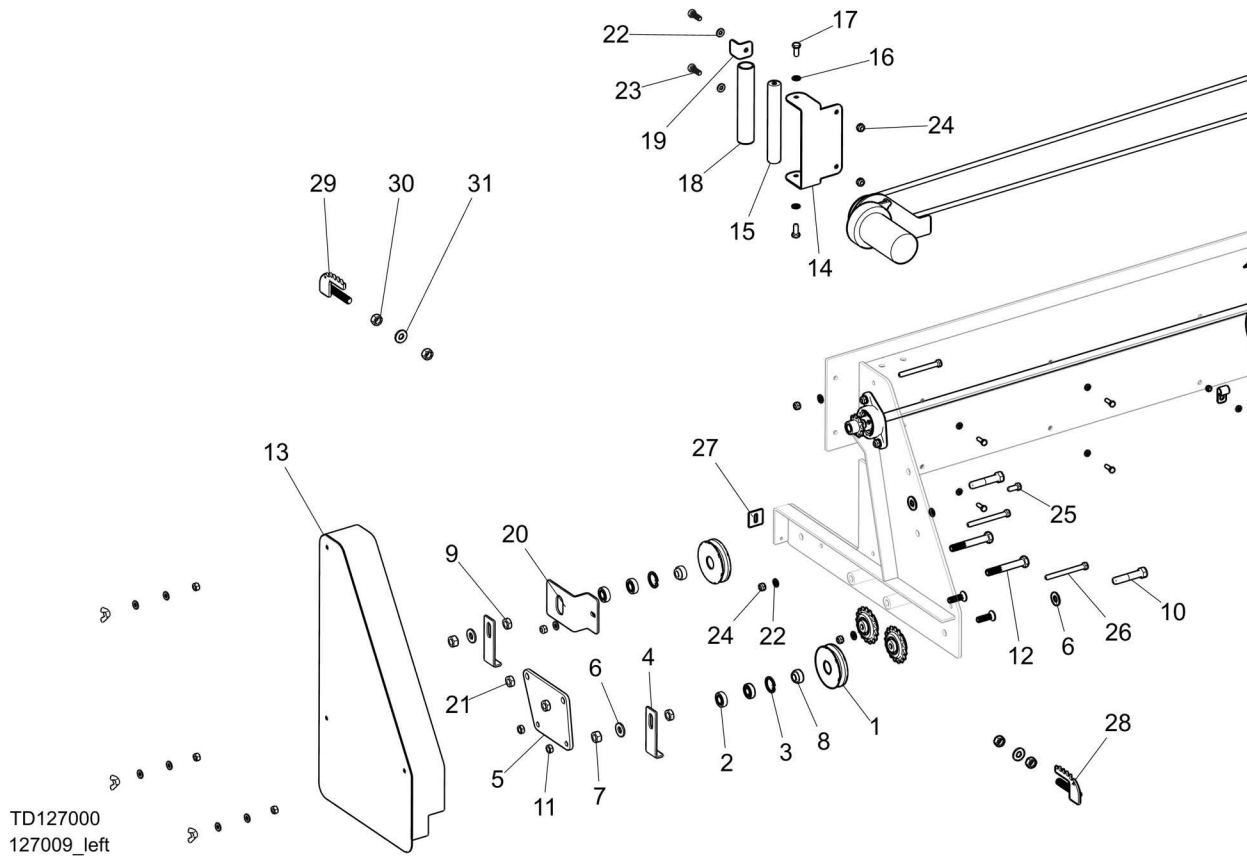

REF	PART #	DESCRIPTION	COMMENTS	QTY.
	065632	Roller Assembly, LT10 Lower		4
1	071016	Roller, 2012 LT10 Mast Track		4
2	015975	Bearing, R8-2RS Blade Guide		8
3	F04254-1	Ring, 1 1/8 IR Tru-Ark		4
4	127180	Plate, Head Keeper		4
5	127181	Plate, Idler Mount		2
6	F05011-2	Washer, 1/2 SAE Flat		8
7	F05010-35	NUT, 1/2-13 FREE HEX, ZINC		4
8	127147	Bushing, Roller Spacer		4
9	F05010-31	Nut, 1/2-13 Zinc Jam		4
10	F05008-74	BOLT, HEX HEAD 1/2-13x2 1/2 GR5 ZINC		4
11	F05027-18	Nut,M10-1.5 Jam		4
12	F05023-32	Bolt, M12-1.75x85 Class 10.9 PT HH		4
13	127151	Cover, Chain Idle		1
	127115	Assembly, Vertical Handle		1
14	127116	Plate, Handle		1
15	127117	Rod, Handle		1
16	F05026-4	Washer, M8 Flat		2
17	F05021-2	Bolt, M8-1.25x20 Class 8 HH		2
18	127118	Handle, Foam		1

REF	PART #	DESCRIPTION	COMMENTS	QTY.
19	127164	Plate, Head Stop		2
20	127165	Plate, Cover Roller		2
21	F05027-19	Nut, M12-1.75 Zinc Jam		4
22	F05026-4	Washer, M8 Flat		30
23	F05021-20	Bolt, M8-1.25 x 25 HH 8.8		4
24	F05010-132	Nut, M8-1.25 Hex Nylock		16
25	F05021-2	Bolt, M8-1.25x20 Class 8 HH		2
26	F05004-247	Bolt, M8x1.25x90mm HH FT CL8.8 Zinc		6
27	127166	Plate, Scraper		2
28	127144	Weldment, Chain tensioner #2 Slabmizer		1
29	127145	Weldment, Chain tensioner #1 Slabmizer		1
30	F05010-212	Nut, M12x1.75 Free Znc		4
31	F05011-124	Washer, M12 Flat Zinc		4

SECTION 4 UP / DOWN ASSEMBLY

4.1 Bearings

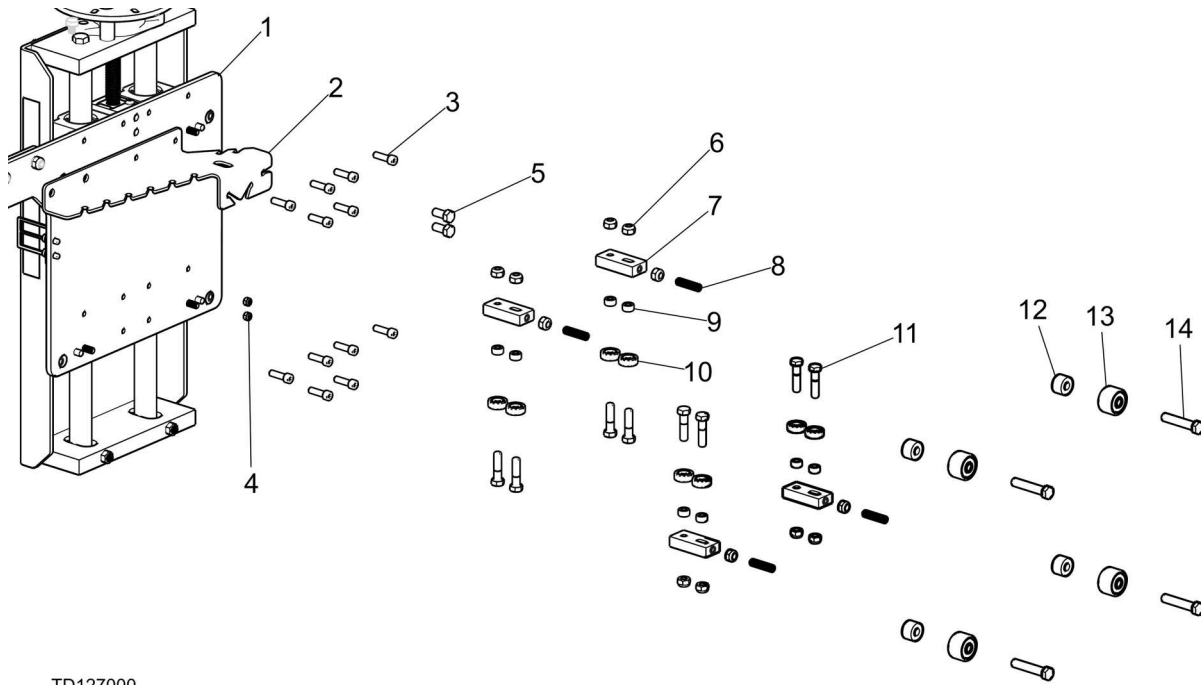

TD127000
127015

REF	PART #	DESCRIPTION	COMMENTS	QTY.
1	127193	Plate, Back	(See Section 4.2)	1
2	127138	Plate, Rope Mount		1
3	F05020-22	Screw, M6-1 x 25 SHC		12
4	F05027-3	Nut, M5-.8 Class 8 Hex Nyloc		2
5	F05021-2	Bolt, M8-1.25x20 Class 8 HH		8
6	F05010-132	Nut, M8-1.25 Hex Nylock		15
7	127059	Block, Bearing Mount		4
8	F05021-57	Screw, M8-1.25x35mm Cup-Point SH Set		8
9	127061	Spacer, Bearing		8
10	127130	Bearings, Ball 608		8
11	F05021-50	Screw, M8-1.0 x 35 SHC		8
12	127060	Spacer, Bearing		4
13	127062	Bearing, CAM 1 1/4		4
14	F05007-158	Bolt, 3/8-16 x 2 HH Tap (FT) Grd 5		4

4.2 Up Down

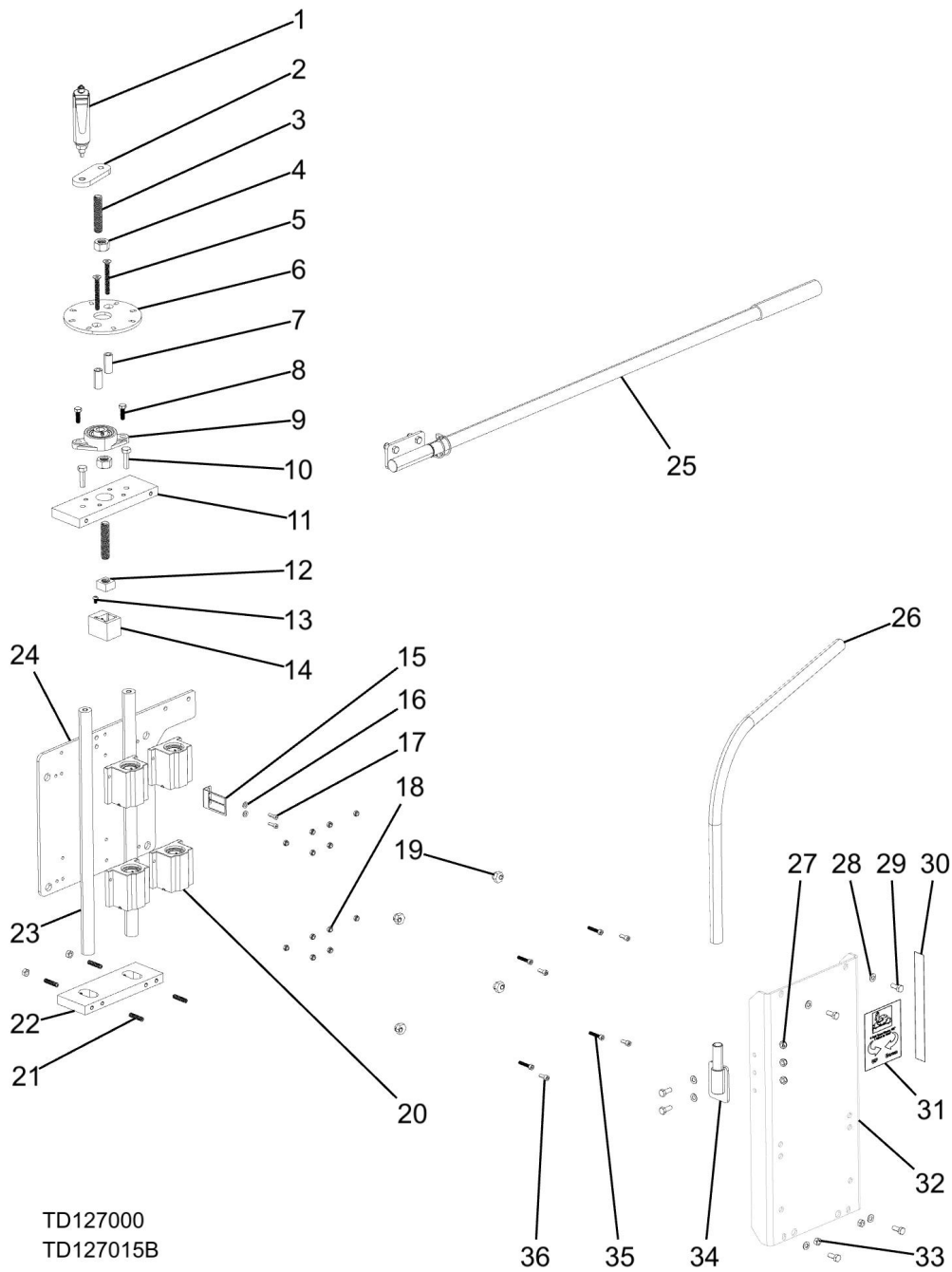

REF	PART #	DESCRIPTION	COMMENTS	QTY.
1	047685	Handle Assembly, Edger	(See Section 4.3)	1
2	127111	Block, Up/Dn Handle		1
3	127109	Rod, Acme 5/8-8x 11 7/8		2
4	127110	Nut, Acme 5/8-8		2
5	F05021-56	Bolt, M8-1.25x70mm FHS FT BO		2
6	127191	Plate, Up/down Latch		1
7	127133	Tube, Spacer		2
8	F05021-20	Bolt, M8-1.25 x 25 HH 8.8		2
9	127112	Bearing, 5/8" Bore 2 Bolt Flange		1

REF	PART #	DESCRIPTION	COMMENTS	QTY.
10	F05022-18	Bolt, M10-1.50 x 35MM HH Gr 8.8		2
11	127190	Flat, Rod Mount Top		1
12	127131	Nut, Acme 5/8-8 Brass		1
13	F05020-92	Bolt, M6-1x10mm BHCS BO		1
14	127132	Block, Amce Nut Mount		1
15	127134	Pointer		1
16	F05026-1	Washer, M6 Flat Class 4		2
17	F05004-259	Screw, M5-0.8x16mm SHCS SS PK/50		2
18	F05010-200	Nut, M6-1.0 Nylon Lock		12
19	127063	Nut, Cam Vertical Adjustments		4
20	127194	Bearing, 1" Linear Ball		4
21	F05021-57	Screw, M8-1.25x35mm Cup-Point SH Set		8
22	127192	Flat, Rod Mount Bottom		1
23	127188	Rod, 1" Chrome		2
24	127193	Plate, Back		1
25	127119	Push Handle	(See Section 4.4)	1
26	127162	Tube, Arm Hose		1
27	F05010-132	Nut, M8-1.25 Hex Nylock		15
28	F05026-4	Washer, M8 Flat		6
29	F05021-2	Bolt, M8-1.25x20 Class 8 HH		8
30	127067	Scale, Up Down		1
31	127207	Decal		1
32	127189	Plate, Motor Mount		1
33	F05010-162	Nut, M8-1.25 Free Zinc		4
34	127160	Weldment, Arm Hose		1
35	F05020-25	Screw, M6-1x30 SHC		4
36	F05004-206	Bolt, M6-1.0x16mm SHCS		4

4.3 Handle Up/Down

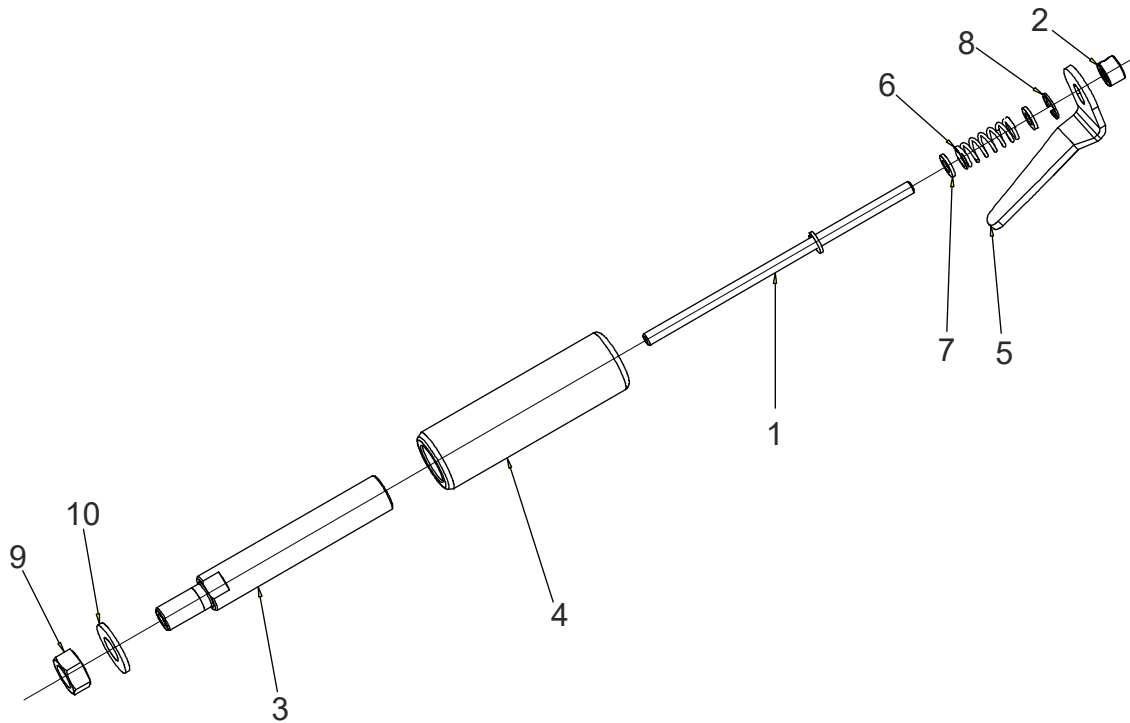

REF	PART #	DESCRIPTION	COMMENTS	QTY.
		HANDLE, UP/DOWN		
1	006496	Shaft Assembly, TBE Handle		1
2	031975	Collar, 1/4 ID Shaft		1
3	047686	Shaft, Edger Handle		1
4	047688	Handle, 25/64 IDx1 1/4 ODx4 1/8 Plastic		1
5	047689	Plate, Edger Handle		1
6	047690	Spring, .48 Dia x1.5 Long SS Compression		1
7	047705	Spacer, .26 ID x .480 ODx1/16		2
8	F04254-47	Ring, 1/2 ID IR Retaining Snap		1
9	F05010-35	Nut, 1/2-13 Free Hex, Zinc		1
10	F05011-2	Washer, 1/2 SAE Flat		1

4.4 Handle, Push

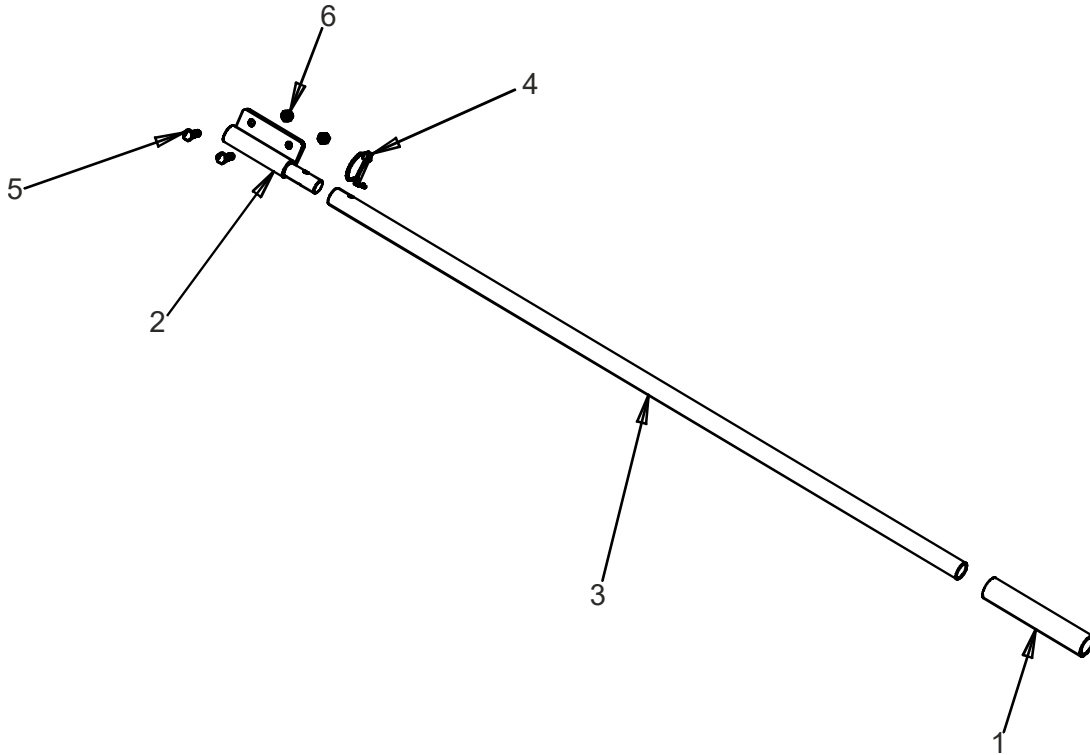

REF	PART #	DESCRIPTION	COMMENTS	QTY.
		HANDLE PUSH		
1	127118	Handle, Foam		1
2	127120	Weldment, Push Handle		1
3	127123	Tube, Push Handle		1
	127255	Tube, Push Handle Wide		1
4	127159	Pin, Handle Lock		1
5	F05021-20	Bolt, m8-25 HH		2
6	F05010-132	Nut M8 Lock		2

SECTION 5 MOTOR ASSEMBLY

5.1 Motor Assembly

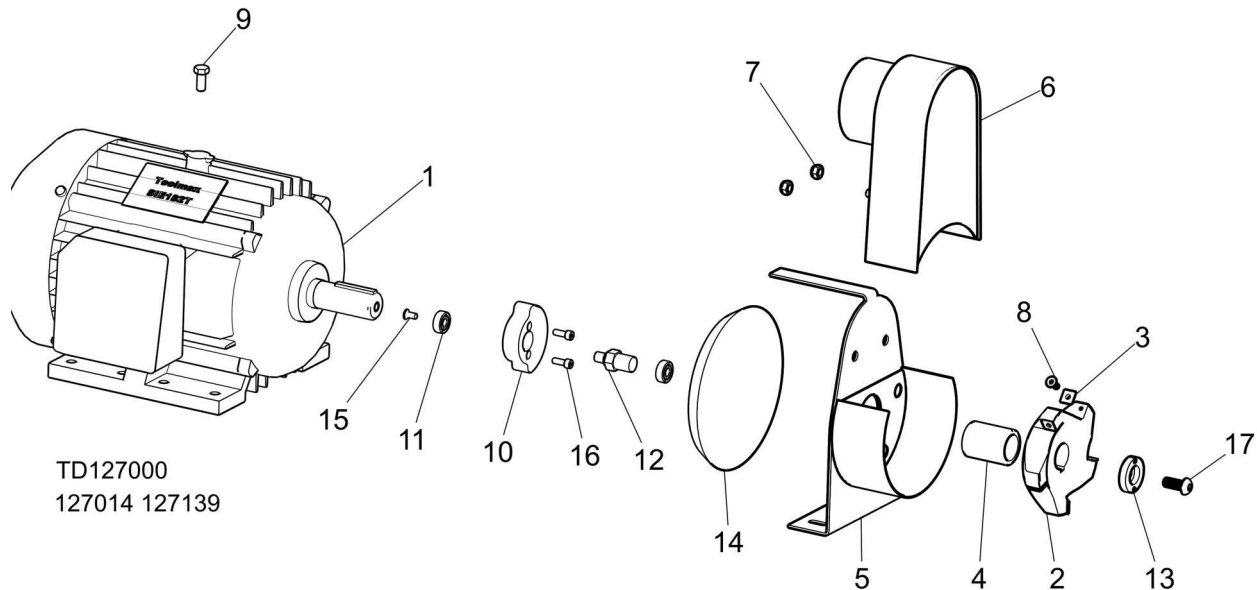

REF	PART #	DESCRIPTION	COMMENTS	QTY.
	127084			1
1	127044	MOTOR, 3 HP 3 PHASE 3490 PRM		1
2	122700	Head, Cutter 5 Tooth 5" Dia	Replaced 127020 on 9/15/2023	1
3	127021	Insert, Cutter 15x15x2.5 - R150		5
4	127124	Bushing, Cutter Spacer		1
5	127022	Weldment, Dust Head Fixed		1
6	127023	Weldment, Dust Head Removable		1
7	F05010-132	Nut, M8-1.25 Hex Nylock		2
8	127209	Bolt, Insert	Torque: 35 lbs/ft (48 N/m)	5
9	F05021-2	Bolt, M8-1.25x20 Class 8 HH		1
	127139	ASSEMBLY SANDING HEAD		1
10	127141	Balance, Orbital		1
11	P10688	Bearing, R6-2NSL SRI-2 ABEC-1		2
12	127142	Stud, Sanding		1
13	127143	Washer, Cutter / Sanding		1
14	127140	Head, Sanding 7		1
15	F05020-11	Bolt, M5-.8 x12 FH SHC		1
16	F05004-259	Screw, M5-0.8x16mm SHCS SS PK/50		2
17	F05022-58	Bolt, M10-1.5x25mm BHCS BO Class 10.9		1

SECTION 6 ELECTRICAL BOX

6.1 Pendant

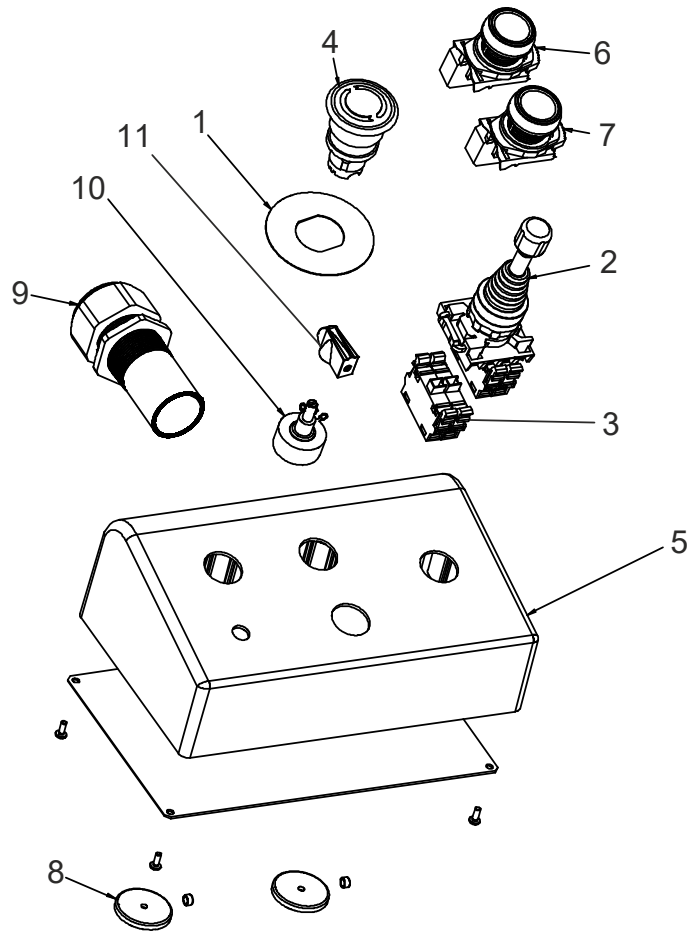

REF	PART #	DESCRIPTION	COMMENTS	QTY.
1	050992	LEGEND, E-STOP ROUND YELLOW		1
2	068424	JOYSTICK, 4P SPRING RTN 22MM		1
3	068425	CONTACT BLOCK, 1 NO ABB		4
4	068940	PUSH BUTTON, MSHRM MNTND RED TM R1 ZB5		1
5	127074	ENCLOSURE, PENDENT		1
6	127085	SWITCH, GREEN		1
7	127086	SWITCH, RED		1
8	127087	MAGNET		2
9	127088	CORD, GRIP		1
10	e07761	POTENTIOMETER, 1K		1
11	P06257	KNOB, FEED RATE WITH SET SCREW		1

6.2 Stand

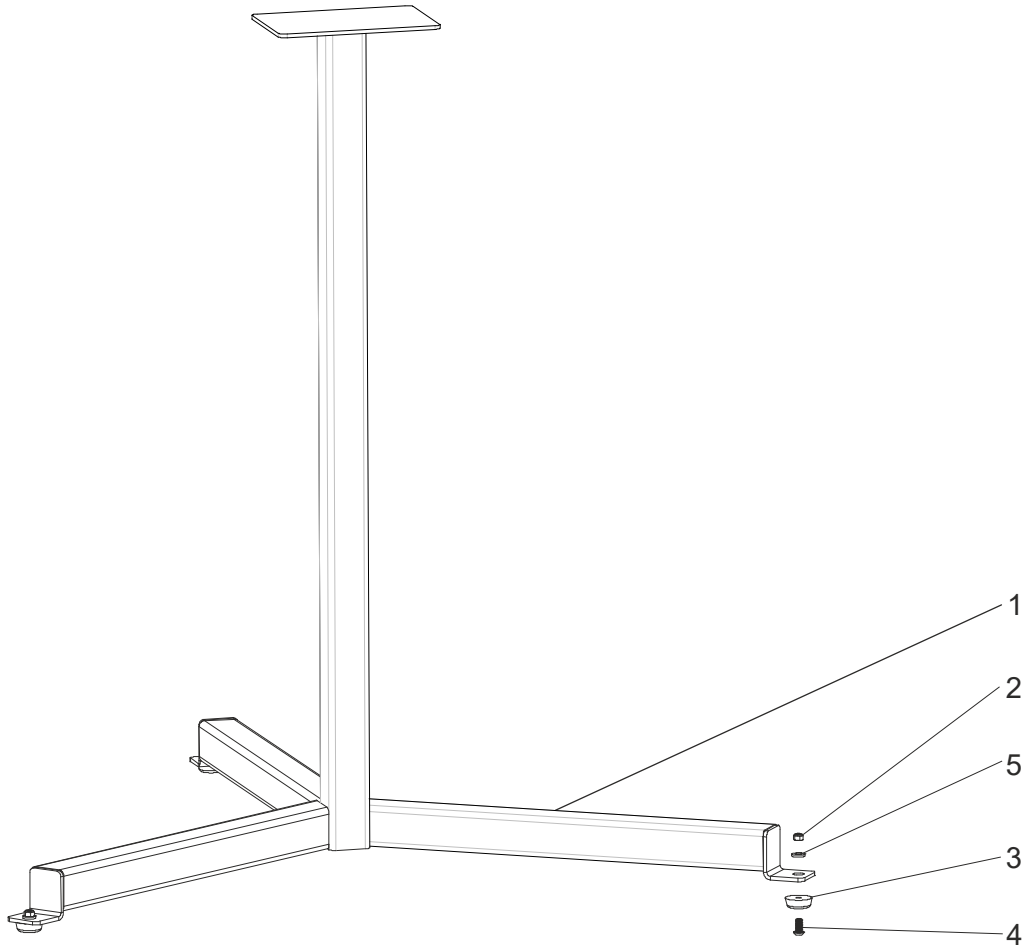

REF	PART #	DESCRIPTION	COMMENTS	QTY.
	127093	STAND		
1	127094	Weldment, Stand		1
2	f05027-3	Nut, M5 Lock		3
3	127206	Bumper, FOOT		3
4	F05020-55	Screw, M5-.8x12mm BHCS SS		3
5	F05026-1	Washer, M6		3

6.3 Enclosure

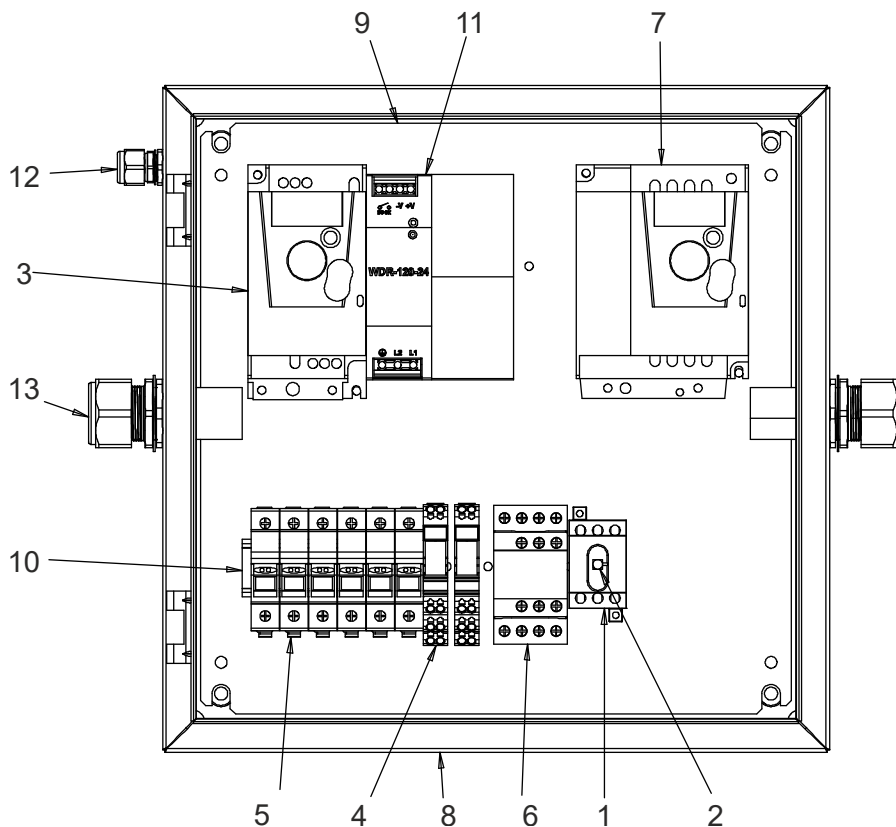

REF	PART #	DESCRIPTION	COMMENTS	QTY.
	127091	ENCLOSURE		1
1	050903-1	Disconnect 40 A 3 HP Non Fused		1
2	051673-1	Shaft, Disconnect 180 mm x 6mm		1
	050883-1	Handle, Disconnect		1
	127079	Switch, Keyed		1
3	069704	AC Drive, ATV12 0.25 HP 230V 1 HP - 3HP		1
4	127070	Relay, 1CO 24 VDC 16 Amp		2
5	127072	Fuse Holder, 2P		3
	127073	Fuse, 20A 500V FLQ Midget Delay		2
	127075	Fuse, 4Amp500V FLQ Midget Delay		2
	127077	Fuse, 3A 500V FLQ Midget Delay		2
6	127078	Contactor, 25Amp 4P 24 VDC Coil		1
7	127083	AC Drive, ATV12 3HP 230V 1HP - 3HP		1
8	127089	Box, Enclosure		1
9	127090	Insert Panel		1
10	127092	Din Rail		2
11	127201	Power Supply, 24VDC 20A 200-500V		1
12	127202	Cord Grip Small		1
13	127203	Cord Grip Large		3