

8180 W 10th St
Indianapolis, IN 46214

MB100EA3U

LT15 Slab-Mizer

Creator	TEM
Create Date	4/30/2020
Last Editor	cumse
Edit date	5/2/2022
Design Revision	A1
Project Type	Schematic project
Total Pages	7
Report Pages	4
Supply Type	220VAC +/- 10% 50/60Hz

Revision History

Date	Revision	Revision Record	Drawn By	Checked By
04/14/22	A1	Production Release	TEM	SDC

		Wood-Mizer®	
Project Description: MB100 Slab-Mizer			
Revision: A1		Pg Desc: Revision History	
Mounting Location: +		Type: Overview	
Prev. pg: 0	Page: 1	Next pg: 2	Total Pgs: 7

Voltage	220V +/- 10%	
Phase	1Ph	
Frequency	50/60	
FLA Machine	20.2A	
FLA Largest Load	20.2A	
Wiring Diagram	MB100	
SCCR	5kA	

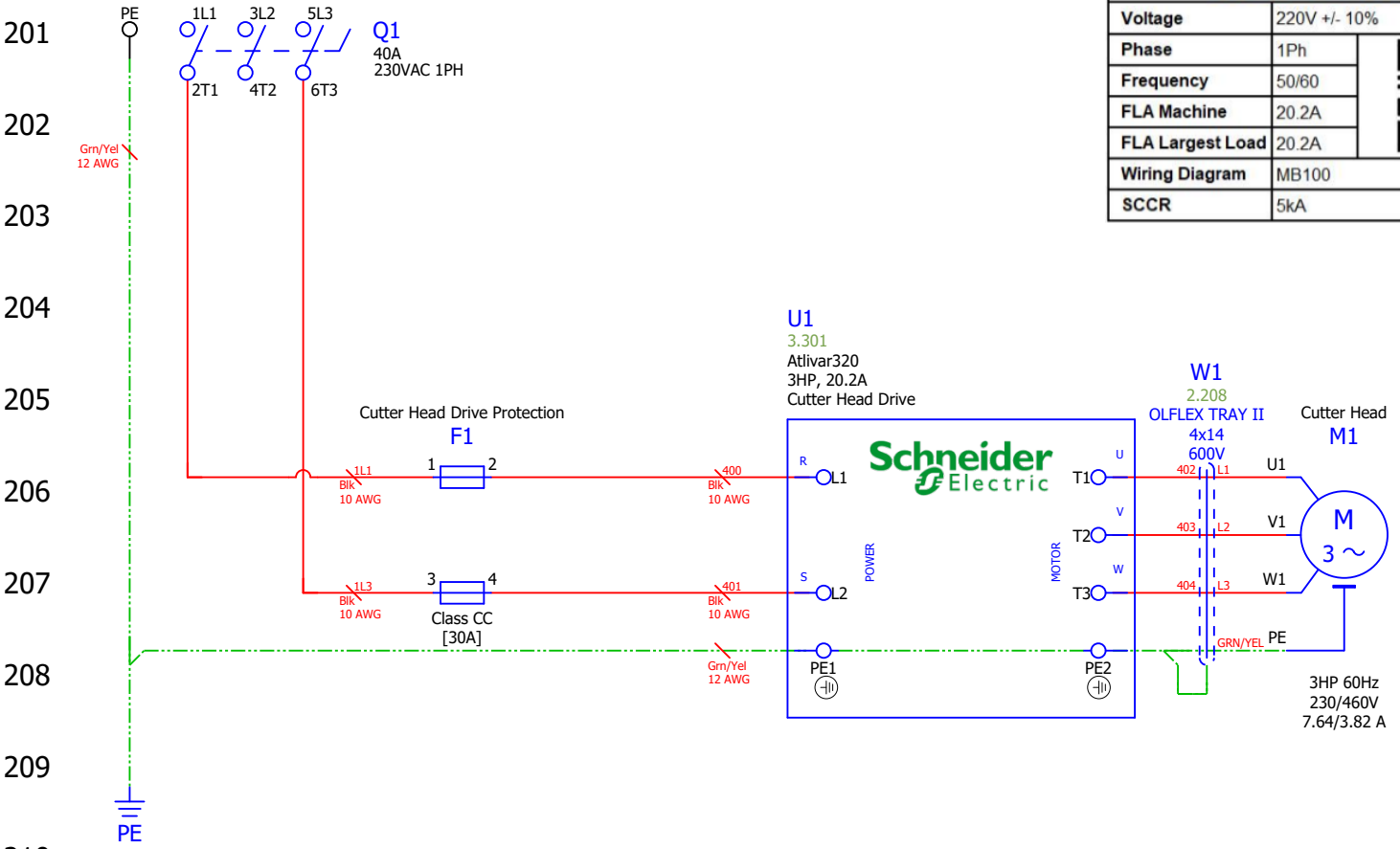

201
202
203
204
205
206
207
208
209
210
211
212
213
214
215
216
217
218
219
220
221

301
302
303
304
305
306
307
308
309
310
311
312
313
314
315
316
317
318
319
320
321

U1
2.205

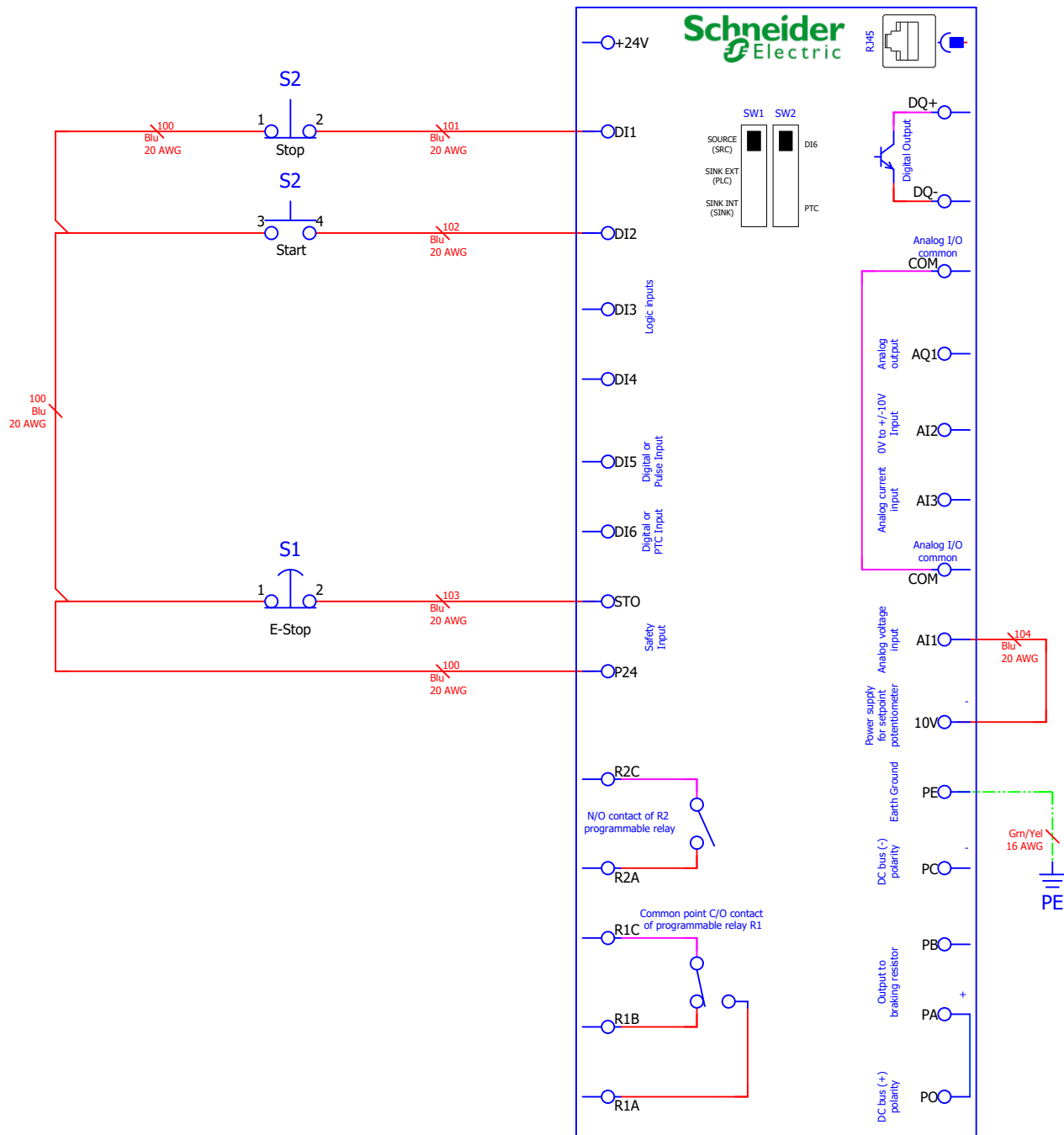

Cable Overview

Cable Designation	Cable Part Number	Cable Description	Cable X-Ref
W1	LAPP-71384004	Cable, Shielded Cutter Head Motor 4x14AWG	2.206

 Wood-Mizer®			
Project Description: MB100 Slab-Mizer			
Revision: A1		Pg Desc: Cable Overview	
Mounting Location: +		Type: Cable overview	
Prev. pg: REPORT 2	Page: REPORT 3	Next pg:	Total Pgs: 7